

PERPETUAL

TROUBLE SHOOTER'S MANUAL

Reg. U. S. Pat. Off.

VOLUME II

by

JOHN F. RIDER

JOHN F. RIDER

1440 Broadway

New York City

Other Manuals by John F. Rider



Perpetual Trouble Shooter's Manual Volume I
Perpetual Trouble Shooter's Manual Volume II
Perpetual Trouble Shooter's Manual Volume III
Specialized Auto Radio Manual Volume I



These manuals are the "standard" in the radio service industry the world over. Their absolute superiority is proved by their use, sale and recommendation by the world's most famous tube companies such as

E. T. Cunningham, Inc.
National Union Radio Corp.
RCA Radiotron Co.
Raytheon Products Corp.

and the test instrument manufacturers such as

Weston, Hickok, Supreme and Readrite

also all the radio receiver manufacturers.

AUTHOR'S FOREWORD

THIS issue of Volume II is slightly different from earlier printings. One of the changes is the method of numbering the pages. You will note that it is the same as used in Volumes I and III, as recently issued.

The reason for this change is that the method of folio or page numbering originally introduced in Volume III proved so much more popular and simple to use than that previously employed in Volumes I and II, that it was deemed most advantageous to establish a uniform method of page numbering and indexing, which would serve best over a period of years.

Present owners of Volume III, that is owners of this manual, purchased prior to November 15, 1933, will find that the index which accompanies Volume III does not conform with the folio or page numbering in this edition of Volume II. This arrangement will cause a slight inconvenience, but we feel that it is for the better, with respect to the use of the manuals in the field.

The complete index contained in Volume III manuals, purchased prior to November 15 or thereabouts, can be used to determine if the information desired is in Volumes I or II or III. If in either of the first two named, further reference to the indices in these two manuals will show the correct page. The same method can be used in connection with this and all future issues of Volume II and Volume I.

Another change is that the point-to-point data, originally contained in one section in the front of the volume, now has been distributed among the respective manufacturers. In every other respect, this issue of Volume II is fully the equal of the earlier printings and in very many cases, has much information not contained in earlier printings.

The pages in this issue have been printed from engravings and we trust that the increased legibility of type, the increased number of cases where electrical values have been elaborated upon, the increased number of socket layouts—in general, more data—will be received with favor.

JOHN F. RIDER

INDEX

HOW TO USE THIS INDEX

The numeral 1 before the page number indicates that the page is in Vol. I. The numeral 2 indicates that the page is in this volume.

	PAGE		PAGE
THE A-C DAYTON CO.		ANSLEY RADIO LABORATORIES	
MODEL		MODEL	
XL-5	Schematic1-1	DC Electric Set	Schematic2-1
XL-10	Schematic1-3	MD-1	Schematic, socket, chassis2-2
XL-20	Schematic1-1	U-1, AC-DC	Schematic2-3
XL-25	Schematic1-1	U-2, AC-DC	Schematic2-4
XL-30	Schematic1-4		
XL-50	Schematic, socket1-2	APPEL-HENDERSON	
XL-60	Schematic1-2	Silver King DC combina-	
XL-61 Battery	Schematic, socket1-4	tion	Schematic, notes2-1
AC-63	Schematic, socket, voltage1-5	Silver King AC combina-	
AC-65	Schematic, socket, voltage1-6	tion	Schematic2-2
AC-66	Schematic, socket, voltage1-7	4-Tube AC	Schematic2-3
XL-70	Schematic1-3	5-Tube AC	Schematic2-3
Navigator	Schematic, socket, voltage1-8	4-Tube Portable	Schematic2-4
		5-Tube Battery Midget	Schematic2-4
ACME APPARATUS CO.		ARGUS RADIO CORP.	
5-Tube Reflex	Schematic1-1	B-125	Schematic1-1
B Eliminator	Schematic1-1	B-195	Schematic1-1
		B-195	Chassis1-3
ACME ELECTRIC & MFG. CO.		ATWATER KENT MFG. CO.	
AC-7	Schematic, socket1-1	10	Schematic, socket1-1
SG-88	Schematic, socket1-1	10-B	Schematic, socket1-1
		12	Schematic, socket1-1
ADVANCE ELECTRIC CO.		19 #4880	Schematic, socket1-2
Falck Superhet "B"	Schematic2-1	20 #4640	Schematic1-2
E	Schematic2-1	20 #7570	Schematic, socket1-2
Falck 77, 88, 89	Schematic2-2	20 #7960	Schematic, socket1-3
		21 #7780	Schematic, socket1-3
ALL-AMERICAN MOHAWK CORP.		30, 35, 48	Schematic, socket1-4
Navajo	Schematic, chassis1-1	32	Schematic, socket1-4
VA	Schematic, socket1-1	36, Early, late Power Pack	Schematic1-6
115-1926 All-Electric	Schematic1-2	37, Early, late	Data1-5
115-1926 Battery	Schematic, socket1-2	37, 37-F, 37-C	Schematic, socket1-7
Mohawk 226	Schematic, socket, cable1-3	37 Power Pack, early, late	Schematic, data1-3
Mohawk 226, 12 Contact	Schematic1-4	38	Schematic, socket1-7
A-10 Eliminator	Schematic1-4	40, 42, 52, 56, 57	Schematic, socket, voltage1-9
44	Schematic, socket1-5	40, 42, 52 Power Pack	Schematic1-9
Forte, 1926	Schematic, socket1-5	40, 42, 44, 52 Power Pack	Chassis layout1-10
60, 61, 62, 65, 66	Schematic, socket, voltage1-6	40, 45 Power Pack	
60, 61, 62, 65, 66 Power	Schematic, wiring, plug1-7	(2nd Type)	Chassis layout1-10
Pack	Schematic, socket, voltage, data1-8	41 DC	Schematic, socket1-11
70, 73, 75	Schematic, socket, voltage1-9	41 Power Pack, 3 types	Schematic, voltage1-12
80, 83, 84, 85, 86, 88	Schematic, voltage1-10	43	Schematic, chassis1-13
90, 25-cycle	Schematic, voltage, socket1-11	43 Power Pack	Schematic, wiring1-14
90, 60-cycle	Schematic, socket1-12	44, 45	Schematic, data1-15
96, 60-cycle	Chassis, plug connections1-13	46, 47, 53	Description, data2-2
90, 25- & 60-cycle SPU	Schematic, socket, voltage1-14	50	Schematic, socket, data1-16
Lyric D	Schematic, socket, voltage1-15	55, 55-C Early	Schematic, voltage, data1-17
H	Schematic, socket, data1-16	55, 55-C Early	Chassis wiring1-18
J	Voltage, values1-17	55, 55-C Late	Schematic, chassis1-19
J	Schematic, socket1-18	55-F, 55-FC Early	Chassis wiring1-20
K	Schematic, socket, data1-19	55-F, 55-FC Early	Schematic, chassis1-21
P	Schematic, socket, data1-20	55-F, 55-FC Late	Chassis wiring1-22
C-6 Studio	Schematic, socket, data1-21	55-F, 55-FC Late	Voltage, service, data1-24
S-6	Voltage, data1-22	60, 60-C 1st & 2nd Types	Schematic, data1-25
S-6	Schematic, socket, data1-23	60, 60-C Early	Schematic, chassis1-27
S-7	Voltage, data1-24	60, 60-C Late	Schematic, data1-26
S-7	Schematic, socket, data1-25	61, 61-C DC, Early	Schematic, socket, voltage1-28
S-8	Voltage, data1-26	61, 61-C Late	Chassis wiring1-29
S-8	Schematic1-27	66	Schematic, data1-30
DC		66	Voltage, socket1-32
		66	
		67, 67-C Battery, Early,	Schematics1-31
		Late	Voltage, socket1-32
		70, 74, 76, Chassis D	Schematic, data1-33
		70, 74, 76, Chassis D-1	Chassis wiring1-34
		70, 74, 76, Chassis D-2	Schematic, voltage1-35
		70, 74, 76, Chassis D-2	Chassis wiring1-36
		70, 74, 76, Chassis F	Chassis wiring1-37
		70, 74, 76, Chassis F	Schematic, data1-38
		70, 74, 76, Chassis L-1	Chassis wiring1-39
		70, 74, 76, Chassis L-1	Schematic, data1-40
		70, 74, 76, Chassis L-2	Schematic, data1-41
		70, 74, 76, Chassis L-2	Chassis wiring1-42
		and P	Voltage, notes1-44
		76, Chassis P	Schematic, data1-43
		70, 76, Chassis Q	Voltage, socket, notes1-45
		70, 76, Chassis Q	Schematic, chassis1-46
		72, Chassis H-1	Schematic1-47
		72, Chassis H-1	Voltage, chassis1-48
		72, Chassis H-1, below	
		#5,855,201	Chassis layout, data1-49
		72, Chassis H-2	Chassis, voltage1-50
		72, Chassis H-2	Schematic1-51
		72, Chassis H-2, above	
		#5,855,201	Chassis layout, data1-52
		80, 80-F, 83, 83-F	Schematic1-53
		80, 80-F, 83, 83-F	Chassis, socket, voltage, data1-54
		81, 81-B 81-C	Schematic1-55
		80, 81, 82, 82-D, 84-D, 85	Voltage, data1-56
		82-D	Schematic1-57
		82-D	Chassis, socket, data1-58
		82-D, 2nd Type	Schematic2-1
		82, 82-F	Schematic1-59
		82, 82-F	Chassis, socket, data1-60
		82-Q, 1st Types, below	
		#2,550,940	Schematic2-3
		82-Q, 1st Type	Chassis wiring, data2-4
		84-D	Schematic1-61
		84-D	Chassis, data1-62
		84, 84-F Early	Schematic2-5
		84, 84-F Late	Schematic2-7
		84, 84-F, Early, Late	Chassis layouts, data2-8
		84-Q, Early and Late	Schematic2-9
ACME APPARATUS CO.		ATWATER KENT MFG. CO.	
5-Tube Reflex	Schematic1-1	10	Schematic, socket1-1
B Eliminator	Schematic1-1	10-B	Schematic, socket1-1
		12	Schematic, socket1-1
ACME ELECTRIC & MFG. CO.		19 #4880	Schematic, socket1-2
AC-7	Schematic, socket1-1	20 #4640	Schematic1-2
SG-88	Schematic, socket1-1	20 #7570	Schematic, socket1-2
		20 #7960	Schematic, socket1-3
		21 #7780	Schematic, socket1-3
		30, 35, 48	Schematic, socket1-4
		32	Schematic, socket1-4
		36, Early, late Power Pack	Schematic1-6
		37, Early, late	Data1-5
		37, 37-F, 37-C	Schematic, socket1-7
		37 Power Pack, early, late	Schematic, data1-3
		38	Schematic, socket1-7
		40, 42, 52, 56, 57	Schematic, socket, voltage1-9
		40, 42, 52 Power Pack	Schematic1-9
		40, 42, 44, 52 Power Pack	Chassis layout1-10
		40, 45 Power Pack	
		(2nd Type)	Chassis layout1-10
		41 DC	Schematic, socket1-11
		41 Power Pack, 3 types	Schematic, voltage1-12
		43	Schematic, chassis1-13
		43 Power Pack	Schematic, wiring1-14
		44, 45	Schematic, data1-15
		46, 47, 53	Description, data2-2
		50	Schematic, socket, data1-16
		55, 55-C Early	Schematic, voltage, data1-17
		55, 55-C Early	Chassis wiring1-18
		55, 55-C Late	Schematic, chassis1-19
		55-F, 55-FC Early	Chassis wiring1-20
		55-F, 55-FC Early	Schematic, chassis1-21
		55-F, 55-FC Late	Chassis wiring1-22
		55-F, 55-FC Late	Voltage, service, data1-24
		60, 60-C 1st & 2nd Types	Schematic, data1-25
		60, 60-C Early	Schematic, chassis1-27
		60, 60-C Late	Schematic, data1-26
		61, 61-C DC, Early	Schematic, socket, voltage1-28
		61, 61-C Late	Chassis wiring1-29
		66	Schematic, data1-30
		66	Voltage, socket1-32
		66	
		67, 67-C Battery, Early,	Schematics1-31
		Late	Voltage, socket1-32
		70, 74, 76, Chassis D	Schematic, data1-33
		70, 74, 76, Chassis D-1	Chassis wiring1-34
		70, 74, 76, Chassis D-2	Schematic, voltage1-35
		70, 74, 76, Chassis D-2	Chassis wiring1-36
		70, 74, 76, Chassis F	Chassis wiring1-37
		70, 74, 76, Chassis F	Schematic, data1-38
		70, 74, 76, Chassis L-1	Chassis wiring1-39
		70, 74, 76, Chassis L-1	Schematic, data1-40
		70, 74, 76, Chassis L-2	Schematic, data1-41
		70, 74, 76, Chassis L-2	Chassis wiring1-42
		and P	Voltage, notes1-44
		76, Chassis P	Schematic, data1-43
		70, 76, Chassis Q	Voltage, socket, notes1-45
		70, 76, Chassis Q	Schematic, chassis1-46
		72, Chassis H-1	Schematic1-47
		72, Chassis H-1	Voltage, chassis1-48
		72, Chassis H-1, below	
		#5,855,201	Chassis layout, data1-49
		72, Chassis H-2	Chassis, voltage1-50
		72, Chassis H-2	Schematic1-51
		72, Chassis H-2, above	
		#5,855,201	Chassis layout, data1-52
		80, 80-F, 83, 83-F	Schematic1-53
		80, 80-F, 83, 83-F	Chassis, socket, voltage, data1-54
		81, 81-B 81-C	Schematic1-55
		80, 81, 82, 82-D, 84-D, 85	Voltage, data1-56
		82-D	Schematic1-57
		82-D	Chassis, socket, data1-58
		82-D, 2nd Type	Schematic2-1
		82, 82-F	Schematic1-59
		82, 82-F	Chassis, socket, data1-60
		82-Q, 1st Types, below	
		#2,550,940	Schematic2-3
		82-Q, 1st Type	Chassis wiring, data2-4
		84-D	Schematic1-61
		84-D	Chassis, data1-62
		84, 84-F Early	Schematic2-5
		84, 84-F Late	Schematic2-7
		84, 84-F, Early, Late	Chassis layouts, data2-8
		84-Q, Early and Late	Schematic2-9

ATWATER KENT—Continued

MODEL		PAGE
84-Q, Early and Late	Chassis layout, data.....	2-10
85, 85-F	Schematic	1-63
85, 85-F	Chassis, socket, data.....	1-64
85-Q, 1st Type, below #163,767	Schematic	2-11
85-Q, 1st Type	Chassis, socket, data.....	2-12
86, 86-F, 1st Type, below #6,876,861	Schematic	2-13
86, 86-F, 1st Type	Chassis, data	2-14
87, 1st Type, below #2,525,871	Schematic	2-15
87, 1st Type	Chassis, data	2-16
88, 89-F, 89-P, 1st Type	Schematic	2-17
89, 89-F, 89-P	Chassis, data	2-18
Phonograph Pickup	Sketches, adjustments	2-19
Phonograph Pickup	Schematic, data	2-20
80, 81, 82, 84, 85, 86, 87, 89	Voltage, data	2-5

ATCHISON RADIO MFG. CO.

5-AC	Schematic	1-1
5-DC	Schematic	1-1
6-AC	Schematic, power unit chassis.....	1-2
5	Chassis layout	1-3
6	Chassis layout	1-3

AUDIOLA RADIO CO.

527	Schematic	1-1
627	Schematic	1-1
6-T (1927)	Schematic	1-2
8-T (1927)	Schematic	1-2
8430	Schematic, socket, voltage.....	1-3
80-B, 7830	Schematic, socket	1-4
81 Series	Schematic, voltage	1-5
81 Super	Schematic, voltage	1-6
Audiola Jr.	Schematic, socket	1-7
6-Tube Pentode #1	Schematic, socket	2-1
7-Tube Super Pentode #1	Schematic, socket	2-2
4-Tube Pentode #1	Schematic, socket	2-2
5-Tube Pentode #1	Service notes	2-5
81 Super	Schematic	2-6
6-Tube Jr. #1	Schematic	2-6
6-Tube Jr. #2	Schematic, socket	1-8
8-Tube Super Pentode #1	Schematic	1-9
9-Tube Super Pentode #1	Schematic	1-10
889	Schematic	2-3
9-T-45 Super #1	Schematic	2-3
10-Tube Super #1	Schematic	2-3
9-Tube Super (2) Pentode #1	Schematic	2-4

AUTOMATIC RADIO MFG. CO.

Tom Thumb Screen-Grid 4, Battery	Schematic	1-1
44, V-45, V-46, C-45, P-46	Schematic	2-1
P-35, 34	Schematic	2-2

NATHANIEL BALDWIN & CO.

80	Schematic, Misc.	1-1
----	-----------------------	-----

BALKEIT RADIO CO.

B-7, B-9	Schematic, chassis, data.....	1-1
A-3, A-5, A-7	Schematic, voltage, chassis.....	1-2
C	Schematic, socket, voltage, parts list	1-3
F	Schematic socket, voltage, parts list	1-4

BALKITE PRODUCTS CO.

Specifications	Volts, charging rates, etc.....	1-1
H, J, K, N Chargers	Schematic	1-2
B-180 Form A	Schematic, wiring	1-3
AB-6-180 Form A	Schematic, wiring	1-4
B-180 Form B	Schematic, wiring	1-4
AB-6-185 Form A	Schematic, wiring	1-5
AB-6 Form B	Schematic, wiring	1-6
BY	Schematic, wiring	1-7
A-6	Schematic	1-8
B-X	Schematic, wiring	1-8
B-135 Form A	Schematic, wiring	1-9
B-W	Schematic	1-9
B-H	Schematic	1-10
B Form D	Schematic	1-10
B-W Form D	Schematic	1-10
K-X	Schematic, wiring	1-11

BRANDES PRODUCTS CORP.

B-10	Schematic	1-1
B-10	Voltage, socket, data.....	1-2
B-15, B-16	Schematic	1-3
B-15, B-16	Voltage, socket, data.....	1-4

BREMER-TULLY MFG. CO.

B-T 6	Schematic	2-1
6-40, 6-41	Schematic, socket, voltage.....	1-4
6-40 Power Converter	Schematic	1-5
7-70	Schematic, chassis wiring.....	1-1
7-70 Power Converter	Schematic, socket, voltage.....	1-2
8-12 Counterphase	Schematic, socket	2-1
8-20, 8-21	Schematic, socket, voltage.....	1-3
8 Counterphase	Schematic	1-3
80	Schematic, socket	2-2
81-A	Schematic, socket	1-5
81, 82	Schematic, socket, voltage.....	1-6
S-81, S-82	Schematic, socket	1-7
S-81, S-82 RF	Chassis wiring	2-3
88-A	Schematic	2-2

BROWNING-DRAKE CORP.

5-Tube AC Kit	Schematic	1-1
34, 36, 38	Schematic	1-1
69	Schematic	1-2
70, 71	Schematic	1-3

BRUNSWICK RADIO CORP.

MODEL		PAGE
Radiola Super, UV Cata- comb	Schematic	1-1
Superheterodyne	Panel wiring	1-2
PR-6, 6-Tube 1-B Panel	Schematic	1-3
PR-6, 6-Tube 1-C Panel	Schematic	1-4
6-Tube Cordova	Schematic	1-5
8-Tube Cordova	Schematic	1-6
8-Tube, 2-D Battery	Schematic	1-7
P-3	See RPA-5	2-23
P-11, P-13	Cabinet wiring	1-9
3-KR8, RF	Schematic, voltage	1-10
3-KR8, SPU	Chassis wiring, voltage.....	1-11
5-KR, 5-KRO, 5-KR6, 2-KRO, RF	Schematic, socket, voltage.....	1-12
5-KR, 5-KRO, 2-KRO, 3-KRO, SPU	Schematic	1-13
3-KRO, 3-KR6, RF	Schematic	1-14
5-NO, RF	Schematic, socket, voltage.....	1-15
5-NO, SPU	Chassis wiring	1-16
5-NC8, RF	Schematic, voltage	1-17
3-NC8, 5-NC8, AF	Chassis wiring	1-18
3-NC8, 5-NC8, AF	Schematic	1-19
3-NC8, 5-NC8	Alignment data	2-21
5-NO, 5-NC8, 3-NC8	Trimmer locations	1-20
PR-17-3, 2 types (BRP-5)	Wiring diagrams	1-21
B-17 for PR-17-3	Schematic	1-22
SPU-18 for PR-17-3	Schematic	1-22
SPU-18 for PR-17-3	Chassis wiring	1-23
P-14	Schematic, cabinet wiring.....	1-24
RPA-3A	Chassis wiring	1-25
RPA-4A	Schematic	1-25
RPA-5 used in P-3	Schematic	2-22
RPA-5A, Fanastrope Con- nections	Schematic, wiring	1-3
PR-6	Schematic	1-26
R-1	Schematic, data	1-27
R-1	Chassis wiring	1-28
S-14, S-21, S-31, RF	Schematic	1-29
S-14, S-21, 60-cycle AF and SPU	Schematic	1-30
S-14, S-21, S-31, S-81 RF	Chassis wiring	1-31
S-14, S-21, S-81, S-82, 25-cycle AF	Schematic	1-32
S-14, S-21, S-81, S-82, 25-cycle AF	Chassis wiring	1-33
S-14, S-21, S-81, S-82, 60-cycle AF	Schematic	1-34
15, 22 AC, also 32, 42 AC	Schematic	2-11
15, 22, 32 DC, used in 42 DC	Chassis, voltage, data.....	2-10
15, 22, 32 DC	Chassis wiring	1-35
S-31, 60-cycle AF	Schematic, voltage, data.....	2-1
10	Chassis layout and wiring.....	2-2
10	Schematic	2-3
11, 12, 16, 33 AC	Voltage, socket, data.....	2-4
11, 12, 16, 33 AC	Schematic, socket, voltage.....	2-5
11, 12, 16, 18, 33, AVC, Chassis D	Socket, voltage, data.....	2-6
14, 21, 31 DC	Schematic	2-7
14, 21, 31 DC	Schematic	2-8
15-B	Voltage, socket	2-9
15-B	Data	2-13
42 AC-DC	Adjustment notes	2-14
42 AC-DC	Sketches of details	2-15
42 AC-DC	Wiring diagram, notes.....	2-16
42 AC-DC	Notes, continued	2-17
42 AC-DC	Notes, concluded	2-18
42 AC-DC	Schematic, wiring diagram.....	2-19
42 AC-DC	Details of assembly, wiring diagram	2-20
100, SW Converter	Schematic	2-12

BUCKINGHAM RADIO CORP.

80, 80-B	Schematic, socket, voltage, Misc.1-3
----------	--------------------------------------

BULOVA WATCH CO.

M-501	Schematic, test data.....	2-1
M-501	Chassis layout, assembly wiring, voltage	2-2
M-701, G-781	Schematic, chassis, voltage.....	2-3
M-701, G-781	Test data	2-4
Automatic Clock Control	Chassis wiring	2-4
C-751	Schematic, socket	2-5
C-751	Voltage, service data.....	2-6

BUSH & LANE PIANO CO.

10	Schematic	1-1
12	Schematic, socket, voltage.....	1-2

CAPEHART CORPORATION

10, 12-C	Chassis, service notes, part 1.....	2-1
10, 12-C	Service notes, part 2.....	2-2
10, 12-C	Service notes, part 3.....	2-3
10, 12-C	Service notes, part 4.....	2-4
400, 401, 402	Schematic	1-1
400 Series, PZ Amplifier	Chassis wiring	1-2
400 Series, RF	Chassis wiring	1-3
400, 401, 402	Complete wiring diagram.....	1-4

CLEARTONE RADIO CORPORATION

60 Goldcrest	Schematic	1-1
70 Clearodyne	Schematic	1-1
80 (Improved)	Schematic	1-2
100 Series	Schematic	1-2
110	Schematic	1-3
112	Schematic	1-3

COLONIAL RADIO CORP.

16-6	Schematic	1-1
16-5	Schematic	1-2
17-5	Schematic	1-2
20	Schematic	1-3
21	Schematic	1-3
25	Schematic, socket	1-4
26	Schematic, socket	1-6

COLONIAL RADIO—Continued

MODEL	PAGE
28 AC, Serial #90,001	Schematic, socket1-6
28 DC, Serial #85,001	Schematic, socket1-7
31 DC	Schematic, socket, voltage.....1-8
31 DC	Chassis wiring, data.....1-9
31 AC	Voltage1-9
31 AC	Schematic, socket1-10
32 DC, Issue A	Chassis wiring1-11
32 DC, Issue A	Schematic, socket, voltage.....1-12
32 DC, Issue J	Chassis wiring1-13
32 AC, Issue J	Schematic, socket, voltage.....1-14
33, 34 DC	Schematic, socket, voltage.....1-16
33, 34, 35 AC	Schematic1-15
33, 34, 35 Remote Control	Schematic, wiring, cable.....1-17
33, 34, 35 AC	Chassis layouts2-1
33, 34, 35 AC	Remote Control notes2-2
33, 34, 35 AC	Parts list2-3
36 DC	Schematic, socket2-4
36-P	Schematic1-19
36, 114	Chassis wiring, parts list.....2-6
36, 114	Data on parts2-5
36, 114	Schematic, socket2-7
37	Chassis wiring2-8
37	Parts coding, voltage.....2-9
37-P	Schematic2-10
38, 117	Schematic2-11
39, 125	Schematic1-18
39, 125	Chassis wiring2-18
39, 125	Voltage, parts coding.....2-12
40, 43	Schematic, socket, data.....2-16
40, 43, Battery	Chassis wiring2-14
41, 42	Schematic1-18
41, 42	Parts coding2-19
41	Chassis wiring, voltage.....2-17
42	Chassis wiring2-18
41-P	Schematic2-16
44 Super	Chassis wiring2-20
44 Super	Schematic, voltage, data.....2-21
44 Super	Parts coding2-22
46 Midget	Chassis wiring, parts coding.....2-23
46 Midget	Schematic, voltage, data.....2-24
47	Chassis wiring2-25
47, 48	Schematic, socket, voltage.....2-26
47, 48	Parts coding2-27
48	Chassis wiring2-28
49 Midget	Chassis wiring, voltage.....2-29
49 Midget	Schematic, socket, parts coding.....2-30
50 AVC	Chassis wiring2-31
50 AVC	Schematic, socket2-32
50 AVC	Voltage, parts coding2-33

COLUMBIA PHONOGRAPH CO.

C-1, C-3	Schematic, socket1-1
C-2, C-4	Schematic, socket1-2
C-5 (205)	Schematic, socket, voltage.....1-3
C-5 (810)	Schematic, socket1-3
C-6, C-7	Schematic, socket1-4
31, 33	Schematic, socket, voltage.....2-2
31, 33	Chassis, test data.....2-1
32, 34	Chassis layouts2-3
900, 901	Schematic, socket1-4
902	Schematic, socket1-5
920, 990	Schematic1-6
930	Schematic, socket1-6
930-300	Schematic, socket1-7
931	Schematic, socket1-7
940	Schematic, socket2-4
950	Schematic, socket1-8
961	Schematic, socket1-9
980	Schematic, socket1-10

COLUMBIA RADIO CORPORATION

SG-8	Chassis wiring, voltage.....1-1
SG-8	Schematic1-2

CONTINENTAL RADIO CORPORATION

Slagle 9 with '71-A	Schematic, socket, voltage.....1-1
Slagle 10, A and B with '71-A Power Pack	Schematic, socket1-2
Slagle 29-C with '71-A Power Pack	Schematic, socket1-3
Slagle 29-A and 29-B with '50 Power Pack	Schematic, socket1-4
Slagle 29-C and 29-D with '50 Power Pack	Schematic, socket1-5
Star Raider, R-20, R-30, R-40	Schematic1-6

CROSLLEY RADIO CORP.

XJ, XL	Schematic, socket, chassis wiring1-1
V	Schematic2-7
2-Step A-F. Amplifier	Schematic2-7
3-B, 3-C	Schematic, chassis wiring.....1-1
4-29	Schematic, socket1-2
RFL 60, 75	Schematic, socket1-2
RFL 90	Schematic, socket1-3
6-60, 6-85	Schematic, socket1-3
401 Bandbox Jr.	Schematic, socket, chassis.....1-4
401-A Bandbox Jr.	Schematic, socket1-4
601 Bandbox	Schematic, socket, voltage, chassis1-5
AC Power Unit for AC-7	Schematic1-5
602 AC Power Converter for Models 104, 105, 106	Schematic, data1-6
602 AC Bandbox	Schematic, socket1-7
602 Power Pack	Schematic1-7
104, 105, 106 Power Converter	Schematic1-7
104-R, 105-R Power Converter	Schematic1-7
608 Gembox	Schematic, socket, voltage, chassis1-8
609 Gembox, 610 Gembox	Schematic, socket, voltage, chassis1-9
704 Jewellbox	Schematic, socket1-10
704-A Jewellbox	Voltage1-10

MODEL

704-A Jewellbox	1-6
704-B	1-7
705	1-8
706	1-9
804	1-10
Trirdyn	1-11
51	1-12
5-38	1-13
Buddy, Chum	1-14
7	1-16
7-1	1-15
7-1	1-17
7-2	2-1
AC-7, AC-7C	2-2
20, 21, 22	2-3
26	2-4
27, 28	1-19
30S, 31S, 33S, 34S	2-6
40S, 41S, 42S, 82S	2-5
41, 41-A, 42	2-7
48	2-8
53, 54, 57	2-9
55	2-10
56	2-11
55, 56	1-18
58	2-18
59 AC	2-12
59 AC	2-16
60S, 61S, 62S, 63S	2-14
76	1-18
77-1	2-19
77-A, 77-B, 77-L	2-17
84-C, 84-D	2-18
90, Roamio	2-16
120	2-21
121 Series A	2-22
121 Series B	2-23
122	2-24
123	2-25
124	2-26
122, 123, 124	2-27
125	2-28
126	2-29
126-1	2-30
127	2-31
127	2-32

DE FOREST RADIO CORPORATION

F-5	Schematic, Misc1-3
D-10	Schematic, Misc1-3
CS-5	Schematic, Misc1-3
D-17	Schematic, Misc1-3

DELCO RADIO CORP.

3002	Schematic, socket, chassis wiring, voltage1-1
3002	Chassis layout, control wiring, data1-2

DEWALD RADIO

AC-145	Schematic2-1
AC-245	Schematic2-1
AC 14-45	Schematic, socket, voltage.....2-2
AC 24-45	Schematic2-2
AC 171-2	Schematic, socket, voltage.....2-3
DC 178-4	Schematic2-3
DC 273	Schematic2-3
AC 524	Schematic, chassis2-4
AC 447-M	Schematic2-5
DC 532-3	Schematic2-5
AC 535-6	Schematic2-6
AC 547	Schematic2-6
AC 547-A	Schematic2-7
DC 637-8	Schematic2-7
DC 632	Schematic, socket2-8
AC 724	Schematic2-9
AC 724	Chassis views2-10

EARL RADIO CORP.

21-DC, 22-DC	Schematic, socket1-1
121	Schematic1-1
21, 22 AC	Schematic, socket, voltage.....1-2
21, 22 AC	Data2-1
24-DC, 31-DC, 32-DC	Schematic, socket1-3
31, 32 AC	Schematic, socket, voltage.....1-4
31, 32 AC	Data2-2
33-S, AC	Schematic1-3
41, 42 AC	Schematic, socket, voltage.....1-5
41, 42 AC	Data2-3

ECHOPHONE RADIO MFG. CO.

S-3	Schematic1-1
S-3 Revised	Schematic1-1
S-3	Voltage, data1-2
S-3	Chassis views1-3
S-4	Schematic1-4
S-4	Voltage, data1-5
S-4	Chassis views1-6
S-5 Dynatron	Schematic, socket, data.....1-7
S-5 Revised	Schematic, socket, data.....1-8
S-5	Voltage, chassis layout.....1-9
F	Voltage2-1
F	Schematic, socket, data.....2-2
40	Schematic, socket, data.....2-3
40	Voltage2-1
60	Schematic, socket, data.....2-4
60	Voltage2-6
80	Schematic, socket, data.....2-5
80	Voltage2-6
90	Schematic, socket, data.....2-7
90	Voltage, notes2-8

THOMAS A. EDISON, INC.

MODEL	PAGE
C-1, Chassis SC	Schematic, socket, voltage.....1-1
C-1, Chassis SC, Power Unit	Chassis wiring1-2
R1, R2, C2, Chassis Jr. and Jc, 25 cycles	Chassis wiring1-3
R1, R2, C2, Chassis Jr. and Jc	Schematic, socket, voltage.....1-4
R1, R2, C2, 60 cycles	Schematic, chassis wiring.....1-5
R4, R5, C4 (Unit Type 7K)	Chassis wiring1-6
R4, R5, C4	Schematic, socket, voltage.....1-7
R4, R5, C4	Chassis views2-1
R4, R5, C4	Parts list1-8
R4, R5, C4, (Power Unit Type 8P)	Chassis wiring1-9
R4, R5, C4 Power Unit	Chassis views2-2
R6, R7	Schematic, socket, voltage.....1-10
Splitdorf Abbey Jr.	Schematic, socket1-11
Splitdorf Abbey Battery	Schematic, socket1-11
Splitdorf R-100	Schematic, socket1-12
Splitdorf R-200	Schematic, socket1-12
Splitdorf RV-695	Schematic, socket1-12
Splitdorf E-175	Schematic1-13

ELECTRAD, INC.

Loflin-White '45	Schematic1-1
A-250	Schematic2-1
C-250	Schematic2-1
D-250	Schematic2-2
E-250	Schematic2-2

ELECTRICAL RESEARCH LABORATORIES, INC.

R-1	Schematic, socket1-1
R-2, RF Unit	Schematic, socket1-2
A-2, AF Unit	Schematic, socket1-2
30, 31, 32, AR-3 (224)	Schematic, socket, voltage.....2-1
35, 37, 38, 39 (230)	Schematic, socket2-5
S-61	Schematic, socket1-1
74, 76 (210)	Schematic, socket2-2
75, 77 (231)	Schematic, socket2-6
81, 82 (245)	Schematic, socket1-5
224 AC	Schematic, socket1-3
224 AC	Chassis, voltage1-4
224-B	Schematic, socket2-3
225	Schematic2-4
271-A	Schematic2-7
335	Schematic, socket1-6
336	Schematic2-8

EMERSON RADIO AND PHONOGRAPH CORP.

F	Schematic, socket, voltage, parts list1-1
65	Schematic, condenser data.....1-2

EXPERIMENTERS INFORMATION SERVICE

Navy C-10	Schematic, Misc.1-4
-----------	--------------------------

FADA RADIO & TELEVISION CORP.

460-A, R-60 Unit	Schematic, socket1-1
475-A, SF 45-75	Schematic, socket, data.....1-2
R-80-A Unit, 480-A, SF 50-80 A	Schematic, socket1-3
480-B, SF 50-80-B	Schematic, socket1-4
472UA, 475UA, 472CA, 475CA	Schematic, socket, parts list...1-5
262UA, 265UA, 262CA, 265CA	Schematic, socket, data.....1-6
C Electric Unit	Schematic, chassis wiring.....1-7
ABC SPU, Types 66-Q and 62-R	Schematic1-8
ABC SPU, 86-V, 82-W	Schematic1-9
10, 11, 30, 31, 10Z, 11Z, 30Z, 81Z	Schematic, socket, parts list...1-10
10, 11, 30, 31, 10Z, 11Z, 30Z, 81Z	Service notes2-1
16, 17, 32, 16Z, 32Z	Schematic, socket, voltage.....1-11
16, 17, 32, 16Z, 32Z	Service notes2-2
18 DC	Schematic, socket1-12
20, 20Z	Schematic, socket, voltage.....1-13
22 Battery	Schematic, socket1-14
25, 25Z	Schematic, socket, voltage, data.1-15
25, 25Z (M-250 and M-250Z Units)	Schematic, socket, voltage.....1-16
35-B	Schematic, voltage, data.....1-17
25, 35-B	Sensitivity adjustments2-3
35, 35Z	Schematic, socket, voltage, data.1-18
40	Schematic, socket, voltage, data.1-19
40	Service notes2-4
41, 42, 44, 46, 47 (KA)	Schematic, socket1-20
41, 42, 44, 46, 47 (KA)	Voltage, data2-5
KF (43), KG (761, 762, 764, 766)	Schematic, data1-21
45, 45Z (KU)	Schematic, socket, data.....1-22
45, 49 (KW)	Schematic, socket, data.....1-23
45, 48, 49	Service notes1-24
50, 70, 71, 72, 50Z, 70Z	Schematic, socket, voltage.....1-25
51 (KO), 53, 57 (KOC)	Schematic, socket, data.....1-30
61, 66 (KX)	Schematic2-6
75, 77	Schematic, socket, voltage, data.1-29
81, 82, 84, 86 DC (KB)	Schematic, socket2-7
122 (KE)	Schematic, socket2-8
160 Neutrodyne Reflex	Schematic1-28
171, 173 (KOC), 110-volt DC	Schematic2-9
E-180, E-180Z	Schematic, chassis wiring, data.1-26
192-A (192S, 192BS Units)	Schematic, socket1-28
E-420, E-420Z	Schematic, chassis wiring, data.1-27

FARRAND MFG. CO.

B Eliminator	Schematic, Misc.1-5
--------------	--------------------------

FEDERAL RADIO CORP.

A-10, 59, 102	Schematic, socket1-1
A-10	Chassis wiring1-2
B	Schematic1-3
B	Chassis wiring1-4

MODEL

C	Schematic, socket1-5
C	Chassis wiring1-6
D	Schematic, socket1-7
D Battery	Chassis wiring1-8
D Code 68-070	Schematic, socket, data.....1-9
D Code 79-070	Chassis wiring1-10
D (60 cycles)	Schematic, socket1-11
E Code 68-060	Schematic, socket1-12
E DC	Chassis wiring1-13
F Code 79-080	Schematic, socket1-14
F Code 79-080	Schematic, socket, data.....1-15
F-10 DC, F-11 DC	Schematic, socket1-16
F (25 cycles)	Schematic, socket, data.....1-17
G (25 cycles)	Schematic, socket, voltage.....1-18
H Code 71-030	Chassis wiring1-19
H Receiver	Chassis wiring1-20
H Power Unit	Schematic, socket1-21
K	Schematic, socket, voltage.....1-22
M	

PAGE

Schematic, socket1-5	
Chassis wiring1-6	
Schematic, socket1-7	
Chassis wiring1-8	
Schematic, socket, data.....1-9	
Chassis wiring1-10	
Schematic, socket1-11	
Schematic, socket1-12	
Chassis wiring1-13	
Schematic, socket1-14	
Schematic, socket, data.....1-15	
Schematic, socket1-16	
Schematic, socket, data.....1-17	
Schematic, socket, voltage.....1-18	
Chassis wiring1-19	
Chassis wiring1-20	
Schematic, socket1-21	
Schematic, socket, voltage.....1-22	

FEDERATED PURCHASER

Cathedral Tone	Schematic1-1
Acratone 2	Schematic2-1
Acratone 5	Schematic2-2

FENWAY

Superheterodyne, Early, Late	Schematic Misc.1-5
------------------------------	-------------------------

FERRANTI, INC.

250, B-3	Schematic, Misc.1-6
250-C	Schematic, Misc.1-6

FREED TELEVISION & RADIO CORP.

NR-5	Schematic1-1
NR-6	Schematic1-1
NR-7	Schematic, socket1-2
NR-8, NR-8A	Schematic, socket1-2
NR-9, NR-9A	Schematic, socket1-3
NR-10	Schematic, socket1-3
NR-11	Schematic, socket1-4
NR-12	Schematic1-4
NR-11 Power Pack	Schematic1-5
ABC Power Pack	Schematic1-5
FE-15	Schematic1-6
FE-13	Schematic1-6
NR-20	Schematic1-6
FE-30	Schematic1-7
40N, 48N	Schematic1-7
50	Schematic1-8
NR-53	Schematic1-22
NR-55 DC	Schematic, socket1-9
NR-55, NR-56 AC	Schematic, socket, voltage.....1-10
NR-57	Schematic, socket1-11
NR-457 Power Unit	Schematic1-11
NR-60 DC	Schematic1-12
NR-60 AC	Schematic, socket1-13
NR-460 AC Power Unit	Schematic1-13
NR-66, 66-A	Schematic, socket1-14
NR-70 AC	Schematic, socket1-15
NR-470 AC	Schematic1-15
NR-77	Schematic, socket1-16
800	Schematic1-16
NR-78 DC, NR-79 DC	Schematic, socket, voltage.....1-17
NR-78 AC, NR-79 AC	Schematic, socket, voltage.....1-18
NR-80 DC	Schematic, socket, voltage.....1-19
NR-80 AC	Schematic, socket, voltage.....1-20
NR-85 AC	Schematic, socket, voltage.....1-21
NR-90-S	Schematic1-22
NR-95 AC	Schematic, socket, voltage.....1-23

JESSE FRENCH & SONS PIANO CO.

8-Tube AC	Schematic, socket, voltage, data.1-1
5-093	Schematic, socket, voltage.....1-2
"G" Junior	Schematic2-1
"G" Junior	Voltage, service notes2-2
H-2 Pentode AC	Schematic2-3
H-2 Special, 110-volt DC	Schematic2-3
H-1	Schematic2-4
H-1	Service notes, voltage.....2-6
U-1	Schematic2-5
U-1	Service notes, voltage.....2-6

CHARLES FRESHMAN CO., INC.

Masterpiece	Schematic1-1
Equaphase	Schematic1-1
G	Schematic, socket, voltage.....1-2
G with G-60-S Power Unit, 2 Types	Schematic, socket, voltage.....1-3
H	Schematic, socket, voltage.....1-4
ABC Power Unit	Schematic1-4
K	Schematic, socket, voltage.....1-5
L	Schematic, socket1-7
M	Schematic, socket, voltage.....1-6
N	Schematic, socket, voltage.....1-7
2N with 2N-60-S Power Unit	Schematic1-8
Q-15, Q-16	Schematic, socket1-9
3-Q-15, 3-Q-16	Schematic, socket, voltage.....1-10
QD-16-S	Schematic, socket, voltage.....1-11

GALVIN MFG. CO.

Motorola Auto Set	Schematic1-1
Motorola Auto Set	Special notes for Buick and Ford "A"

DAVID GRIMES, INC.

New Yorker, 110-volt DC	Schematic, Misc.1-9
Inverse Duplex, type 4-DL	Schematic, Misc.1-9
Inverse Duplex, 1927	Schematic, Misc.1-9

GENERAL ELECTRIC CO.

A-60	See RCA-Victor M-32.....
A-90	See RCA-Victor M-30.....
H-31	See RCA-Victor R-80.....
H-32	See RCA-Victor R-50.....
H-51	See RCA-Victor R-82.....

GENERAL ELECTRIC—Continued

MODEL	PAGE
H-71	See RCA-Victor R-86.....
H-72	See RCA-Victor RAE 59.....
J-70	See RCA-Victor R-4.....
J-75	See RCA-Victor R-6.....
J-80	See RCA-Victor R-8.....
J-85	See RCA-Victor R-12.....
K-50, K-51	See RCA-Victor R-23.....
K-62	See RCA-Victor R-11.....
S-22	See RCA-Victor R-7.....
S-42	See RCA-Victor R-9.....
S-42-B	See RCA-Victor R-43.....
S-132	See RCA-Victor R-10.....
T-12	See RCA-Victor R-5.....
T-12E	See RCA-Victor R-5-X.....
T-41	See RCA-Victor 48.....

GENERAL MOTORS RADIO CORP.

OEM-7 (4 Tube)	Schematic, socket1-1
OEM-7 Super-Sel.	Schematic, socket1-1
OEM-11 (3 Tube)	Schematic, socket1-1
5044 (5 Tube)	Schematic, socket1-2
527 (5 Tube)	Schematic, socket1-2
Day-Fan 5-AC	Schematic1-3
Day-Fan 5-AC SPU	Schematic, data1-3
Day-Fan 6	Schematic, socket1-3
Day-Fan 6 Jr.	Schematic, socket1-4
Day-Fan 6-61 (5050)	Schematic, socket, data1-4
Day-Fan A-5003, A-5010	Schematic, socket1-12
Day-Fan A-5005, A-5020	Schematic, socket, voltage.....2-1
Day-Fan A-5005, A-5020	Chassis wiring, parts list.....2-2
Day-Fan 5524, 5525 SPU	Schematic1-7
Day-Fan 5050 Battery	Schematic1-9
Day-Fan 5050-7	Schematic, socket1-9
Day-Fan 5051 (MG set)	Schematic, socket, data.....1-5
Day-Fan 5052 (110-volt DC)	Schematic, socket1-3
Day-Fan 5053	Schematic, socket1-6
Day-Fan 5057	Schematic, data1-6
Day-Fan 5057 SPU	Schematic1-6
Day-Fan 5060 (32-volt DC)	Schematic, socket1-3
Day-Fan 5065 AC	Schematic, socket, data.....1-7
Day-Fan 5066	Schematic, data1-7
Day-Fan 5077	Schematic1-11
Day-Fan 5080	Schematic, socket, voltage.....1-11
Day-Fan 5091	Schematic, socket, voltage.....1-13
B and C SPU	Schematic1-9
Day-Fan 25, 26, 27, 28, 43, 48	Schematic, socket, voltage.....1-10
Day-Fan 35	Schematic, socket1-10
110, 180, 190, Little General	Schematic, socket, data.....1-19
120, 130, 140 Below #29100A-1700B	Schematic, socket, voltage.....1-14
120, 130, 140 Between #29100A-62100A and 1700B-1964B	Schematic, socket, voltage.....1-15
120, 130, 140 Above #62100A-1964B	Schematic, socket, voltage.....1-16
120, 130, 140	Service notes2-3
150, 160, Pick-up	Service notes2-4
150, 160, Induction Motor	Service notes, Part 1.....2-5
150, 160, Induction Motor	Service notes, Part 2.....2-6
170-E	Schematic, socket, voltage.....1-17
170-E	Chassis wiring, data.....1-18
216, 217, 219, 250 (S-1A, S-1B)	Schematic, socket2-7
216, 217, 219, 250 (S-1A, S-1B)	Voltage, data2-3
220 (S-10A, S-10B)	Schematic, socket, voltage.....2-13
220 (S-10A, S-10B)	Chassis layout, service data.....2-14
251 (S-2A, S-2B)	Schematic, socket2-9
251 (S-2A, S-2B)	Voltage, data2-10
252, 253, 254, 255, 256, 257, 258 (S-3A, S-3B)	Schematic, socket2-11
252, 253, 254, 255, 256, 257, 258 (S-3A, S-3B)	Voltage, data2-12

GENERAL RADIO CO.

210 Amplifier	Schematic1-1
250 Amplifier	Schematic1-1
390 Eliminator	Schematic1-1
320 Oscillator	Schematic1-3
360 Oscillator	Schematic1-3
360-A Oscillator	Schematic1-3
361-B	Schematic, diagrams1-2
403-C	Schematic1-2

GILFILLAN BROS.

33	Schematic, socket1-1
60	Schematic, socket1-2
66	Schematic, socket1-2
100	Schematic, socket1-1

GRAYBAR ELECTRIC CO.

GB-4	See RCA-Victor R-5.....
GB-8	See RCA-Victor R-7.....
GB-9	See RCA-Victor R-11.....
GB-878	See RCA-Victor 48.....
GB-700	See RCA-Victor R-80.....
GB-770	See RCA-Victor R-82.....
GB-900	See RCA-Victor R-86.....
GB-989	See RCA-Victor R-10.....
GG-15	See RCA-Victor R-6.....
GT-7	See RCA-Victor R-4.....
GT-8	See RCA-Victor R-8.....
GC-14	See RCA-Victor R-12.....
811	See RCA-Victor 33.....
500	See RCA-Victor 44.....
550	See RCA-Victor 46.....
340	See RCA-Victor 62.....
600	See RCA-Victor 66.....

A. H. GREBE & CO.

RORB	Schematic1-1
RORD	Schematic1-1
RORE	Schematic1-1

MODEL

RORF	Schematic1-1
RORG	Schematic1-2
RORH	Schematic1-2
RORJ	Schematic1-2
RORK	Schematic1-2
RORL	Schematic1-2
RORN	Schematic1-3
RORO	Schematic1-3
RORQ	Schematic1-3
CR-1	Schematic1-4
CR-2	Schematic1-4
CR-3	Schematic1-4
CR-4	Schematic1-4
CR-5	Schematic1-5
CR-6	Schematic1-5
CR-7	Schematic1-5
CR-8	Schematic1-5
CR-9	Schematic1-7
CR-12	Schematic, socket1-6
CR-13	Schematic1-8
CR-14	Schematic, socket1-8
Broadcast Receiver	Schematic1-6
CR-18 (Special)	Schematic, socket1-7
CR-18 (1 AF Stage)	Schematic1-9
Synchrophase 5,671 SPU	Schematic, socket, voltage.....1-10
Synchrophase 1925	Schematic1-11
Synchrophase MU-1	Schematic1-11
Synchrophase MU-2	Schematic, socket, voltage.....1-12
Synchrophase MU-1	Socket layout1-12
Synchrophase AC-6	Schematic, socket, voltage.....1-15
Synchrophase AC-6 SPU	Chassis wiring (2 types).....1-16
412 Pushpull Amplifier	Schematic, chassis wiring.....1-13
428 DeLuxe Console	Schematic1-14
Synchrophase 7 Battery	Schematic, socket1-17
Synchrophase 7 AC	Schematic, socket, voltage.....1-18
671-B Power Unit	Schematic1-17
Synchrophase SK-4, Early	Schematic, socket, voltage.....1-19
AH-1	Schematic, socket, voltage.....1-20
HS-4, 1 Pentode	Schematic, socket, voltage.....1-21
HS-4 with '45 Pushpull	Schematic, socket, voltage.....1-22
HS-5	Schematic, socket, voltage.....1-23

GRIGSBY-GRUNOW CO.

7-P-6, 7-P-3 (2 types)	Schematic1-2
7-P-6, 7-P-3 (Old wiring)	Chassis wiring1-3
7-P-6, 7-P-3	Chassis wiring1-4
7-BP-6, 7-BP-3	Schematic1-6
7-BP-6, 7-BP-3	Chassis wiring1-7
8-P-6, 8-P-3	Schematic, chassis wiring.....1-9
9-P-3, 9-P-6	Schematic, socket, voltage, data.....1-24
70	Schematic, socket, voltage.....1-1
70-B	Schematic, socket, voltage.....1-5
70-B	Chassis views2-1
90	Schematic1-11
90	Chassis2-3
90-B	Schematic, socket, voltage.....1-12
100	Schematic1-11
100	Chassis2-3
100-B	Schematic1-12
130-A	Schematic, socket, voltage.....1-13
180	Schematic, socket, voltage.....1-8
180	Chassis views2-2
230-A	Schematic, socket1-13
15 Below Serial #65,149	Schematic, data2-4
15	Voltage, chassis views.....2-5
15, 15-B Above #65,150	Schematic2-6
15-B	Chassis views2-7
20, 21, 22, 23	Schematic, socket, voltage, data.....1-14
20	Chassis views1-15
25	Schematic2-8
25	Voltage, chassis views.....2-9
25-B, 251, 253, 254	Schematic, voltage, data.....2-10
25-B, 251, 253, 254	Chassis views, parts list.....2-11
25-B	Alignment data2-13
25-B	Speaker connections2-15
30, 31	Schematic, socket1-16
30	Voltage, data1-17
35, 351, 353	Schematic, voltage, data.....2-12
35	Alignment data, chassis.....2-13
35, 351, 353	Chassis views2-14
35	Speaker connections2-15
353 Record Changer	Notes2-16
50, 52	Schematic, socket, voltage.....1-18
50	Chassis views1-19
60, 61, 62	Schematic, socket1-20
60, 61, 62 (160, 163)	Voltage, data1-21
60, 61	Chassis views1-22
110 (Auto Set)	Schematic, chassis, data.....2-17
120	Schematic, voltage2-18
120	Chassis2-19
120	Chassis, service notes.....2-20
150	Schematic2-21
160, 163	Schematic, socket1-23

GULBRANSEN CO.

13	Schematic, socket2-1
13	Chassis wiring2-2
13	Voltage, data, phonograph schematic2-3
13	Color code, installation data.....2-4
13	Alignment data2-13
20 Series, Early and Late	Schematic2-5
20 Series	Voltage, alignment data.....2-6
20 Series	Chassis layout, parts list.....2-7
23	Schematic, socket2-9
23	Chassis wiring2-8
23	Voltage, notes, phonograph schematic2-11
23	Parts list, phonograph data.....2-10
23	Alignment data2-13
23	Schematic layout, revisions.....2-12
60, 63	Schematic, socket, voltage.....1-1
60, 63	Chassis wiring, data.....1-2
160, 161 (60 cycles)	Schematic, data1-3
160, 163 (25 cycles)	Schematic, voltage1-4
200, 281, 292, 295, 9950	Voltage, socket, data.....1-5
200, 281, 292, 295, 9950	Schematic, socket1-6
362 (Auto Set)	Schematic, socket, voltage, assembly wiring2-14

HAMMARLUND-ROBERTS, INC.		
MODEL		PAGE
H-R 5 Tube	Schematic	1-1
H-R "HI-Q"	Schematic	1-1
H-R "HI-Q" 6	Schematic	1-1
H-R "HI-Q" 29 Jr.	Schematic, chassis wiring, data	1-2
(3 Types)		
H-R "HI-Q" 29 Master	Schematic, socket, data	1-3
(3 Types)		
H-R "HI-Q" 30 (30-R Battery)	Schematic	1-5
H-R "HI-Q" 30 AC	Schematic, socket	1-5
H-R "HI-Q" 30 DC	Schematic, socket, voltage	1-6
H-R "HI-Q" 31	Schematic	1-6

HAMMARLUND MFG. CO.		
Hawk	Schematic	1-1
DeLuxe	Schematic	1-1
Z-4 Commander	Schematic	1-1
Trans-Oceanic Two	Schematic	1-1
AC & DC Converters	Schematic	1-1
Comet Pro, February, 1933	Schematic	2-1

HATRY & YOUNG		
H-Y 7	Schematic, parts list, Misc.	1-10
H-Y 7, Battery	Schematic Misc.	1-10
H-Y, 7-B	Schematic Misc.	1-10

HIGH FREQUENCY LABORATORIES		
A-C Special	Schematic	1-1
9-in-Line	Schematic	1-1
Masterstone 1929	Schematic	1-2
Isotone 10	Schematic	1-2

CHARLES HOODWIN CO.		
Aero Auto	Schematic	2-1
Aero 1932 Converter	Schematic	2-1

HERBERT H. HORN		
Tiffany Tone 101, 110	Schematic, socket, data	2-1
Tiffany Tone 101, 110	Voltage, alignment data	2-2

HOWARD RADIO CO.		
A-5	Schematic, socket	1-1
A-6	Schematic, socket	1-1
SN-7	Schematic, socket	1-2
Green Diamond 8 (Magnetic Spkr.)	Schematic, socket, voltage, data	1-3
Green Diamond 8 (Dynam. Spkr. '71)	Schematic, socket, voltage, data	1-4
Green Diamond 8 (Dynam. Spkr. '46)	Schematic, socket, voltage, data	1-5
SG "A" RF Chassis	Schematic	1-6
SG "C" RF Chassis	Schematic	1-6
SG "A" AF Chassis	Schematic	1-7
SG "C" AF Chassis	Schematic	1-7
F Pentode	Schematic	2-1
H Chassis	Chassis views	2-5
K	Schematic	1-2
O	Chassis views	2-13
Miniature (SG-B)	Schematic, socket	2-14
Cable-Nelson D-4	Schematic, socket, voltage	2-12
10 (T)	Schematic, socket	2-10
10 (T)	Chassis views, parts list, data	2-11
20, 25, 30, 32 (O)	Schematic, socket	2-8
20, 25, 30, 32 (O)	Voltage, servicing data	2-9
35, 40 (H)	Schematic, socket	2-3
35, 40 (H)	Adjustment data	2-4
45, 60 (AVH)	Schematic, socket	2-7
45, 60 (AVH)	Alignment data	2-6
135 DC	Schematic, socket, data	2-2
395, 445, 470, 495 (135 AC Chassis)	Schematic, socket	1-8

INSULINE CORP. OF AMERICA		
Envoy, 6-Tube AC	Schematic	2-1
Envoy Midget DC	Schematic	2-1
Envoy Midget DC (Revised) 2 Types	Schematic	2-2
Envoy, Broadcast-Long Wave DC	Schematic	2-3
Envoy Broadcast-Long Wave AC	Schematic	2-4
Insulette & Mascot, 4-Tube Midget AC	Schematic	2-5
Insulette & Mascot, Broadcast-Long Wave 4-Tube Midget AC	Schematic	2-5
Conquerer Short-Wave AC	Schematic	2-6
Super-Conquerer, Short & Long Wave AC	Schematic	2-7
Universal Companion, AC-DC-Battery	Schematic	2-8
Universal Companion, AC-DC-Battery (Revised)	Schematic	2-9
Conquerer, SW Battery	Schematic	2-10

JACKSON-BELL CO., LTD.		
33	Schematic, data	2-1

J. E. JENKINS & S. E. ADAIR		
3B Mixing Panel	Schematic	1-1
3C Mixing Panel	Schematic	1-1
A (2 Types)	Schematic	1-2
Pushpull Amplifier	Schematic	1-2
Monitor Amplifier	Schematic	1-2
Level Indicator	Schematic	1-2

KELLOGG SWITCHBOARD & SUPPLY CO.		
6-Tube Battery	Schematic	1-1
7-Tube Cascade	Schematic	1-1
Wave Mascot	Schematic	1-1
RFL 701	Schematic	1-2
AC-7-Tube Chassis B	Schematic, voltage	1-2
523, 524, 525, 526, 527, 528 RF	Schematic	1-3

MODEL		PAGE
523, 526 Power Unit	Schematic, socket, voltage	1-4
524, 525, 527, 528 Power Unit	Schematic, socket, voltage	1-5
533, 534, 535, 536 RF Chassis	Schematic, socket	1-6

COLIN B. KENNEDY CORP.		
5	Schematic	1-2
6, Type 421	Schematic	1-2
6, Type 420	Schematic	1-2
10	Schematic, socket, voltage	1-4
15, 16 (Type 430-43)	Schematic	1-1
175 to 25,000 Meters	Schematic	1-1
7-Coronet DC	Schematic, socket	1-3
20, Type 440	Schematic	1-3
20	Schematic, socket, voltage	1-4
22, 36, 38, 40 DC	Chassis layouts	2-1
22, 36, 38, 40 DC	Schematic, parts list, data	2-2
24	Schematic, voltage, chassis, data	2-3
26	Schematic, chassis, notes	1-6
30, Type 435	Schematic, voltage	1-3
30, 32	Schematic, chassis	1-7
34	Schematic, voltage	1-8
34	Chassis wiring	1-9
34	Changes, data	1-10
Coronet 43	Schematic, chassis, voltage	1-11
44	Schematic	2-4
45	Schematic	2-5
50	Schematic, chassis, alignment data	2-6
52	Schematic, socket, voltage, data	2-7
53-SW, 54-SW	Parts list, data	2-3
53-SW, 54-SW	Schematic, chassis, calibration scales	2-9
54 "Globe Trotter"	Schematic, chassis, data	2-10
54-A	Schematic, chassis, data	2-11
56	Schematic, socket, voltage, parts list	2-12
Royal 60	Schematic, socket	1-5
Royal	Schematic	1-5
62	Schematic, voltage, parts list	2-13
62	Chassis, alignment data	2-14
64	Schematic, data	2-15
64	Chassis, alignment data	2-16
Royal 80	Schematic	1-12
220	Schematic	1-1
281	Schematic	1-1
826-B	Schematic	1-12

KING MFG. CO.		
10-K1, 10-SK	Schematic, socket	1-1
25	Schematic, socket	1-1
30	Schematic, socket	1-1
F	Schematic, socket	1-2
F	Schematic, socket	1-2
G	Schematic, socket	1-3
H	Schematic, socket	1-3
J	Schematic, socket	1-4
61	Schematic, socket	1-5
62, 63	Schematic, socket	1-8
71	Schematic, socket	1-8
80	Schematic, socket	1-4
81	Schematic, socket	1-5
82	Schematic, socket	1-5
Royal (97)	Schematic, socket	1-6
Royal (97)	Voltage	1-7
Imperial (98)	Schematic, socket	1-6
Monarch (101)	Schematic, socket, voltage	1-7

KOLSTER RADIO, INC.		
6D, 6E, 6G, 6H (1927)	Schematic, socket	1-1
6-F, 6-J, 6-K, 6-L, 6-M, 6-R	Schematic, socket, voltage	1-2
7-A, 7-B (1926)	Schematic, socket	1-1
8-A, 8-B, 8-C (1926)	Schematic, socket	1-1
K-23 Rectifier	Schematic	1-2
K-20, K-22, K-27	Schematic, socket, voltage	1-3
K-21, K-23, K-23	Schematic, socket, voltage	1-4
K-24 (250)	Schematic	1-5
K-24 (210)	Schematic, socket, voltage	1-5
K-30, K-32	Schematic, socket	1-6
K-42	Schematic, socket, voltage	1-7
K-43, K-43A (1929)	Schematic, socket, voltage	1-8
K-44 (1929)	Schematic, socket, voltage	1-9
K-45	Schematic, socket	1-10
K-45	Voltage, alignment data	2-1
K-60, K-62	Schematic	1-11
K-60, K-62	Voltage, test data	2-4
K-70, K-72	Schematic	1-12
K-70, K-72	Voltage, test data	2-5
K-80, K-82	Schematic	1-13
K-80, K-82	Voltage, test data	2-6
K-90, K-92	Schematic	1-14
K-60, K-62, K-70, K-72, K-80, K-82, K-90, K-92	Condenser adjustments, data	2-3
K-60, K-62, K-70, K-72, K-80, K-82, K-90, K-92	Condenser and resistor data	2-2

R. E. LACAULT		
All Wave Electric 9	Schematic, parts list, Misc.	1-11
LR-4	Schematic, Misc.	1-11
L-2 Ultradyne	Schematic, Misc.	1-11

LANG RADIO CO.		
BA-5	Schematic, socket	1-1
BA-5-P	Schematic, socket	2-2
BD-5-P	Schematic, socket	1-1
BD-6	Schematic, socket	1-1
BD-6-P	Schematic, socket	1-2
F-7, 110-Volt DC	Schematic, socket	2-1
F-9	Schematic, socket	1-2
J-7	Schematic, socket	1-2
M-7	Schematic, socket	1-3
MA-7	Schematic, socket	2-3
MD-7	Schematic, socket	2-3
R-8	Schematic, socket	1-3
SA-7	Schematic	2-4
SA-8	Schematic, socket	2-4

C. R. LEUTZ, INC.		PAGE
MODEL		
C-10, Navy Model	Schematic	1-1
Silver Ghost	Schematic	1-1
C	Schematic	1-1
Trans-Oceanic	Schematic	1-2
Seven Seas	Schematic	1-2
LINCOLN RADIO CORP.		
8-80	Schematic	1-1
31	Schematic	1-1
MADISON-MOORE		
Superheterodyne	Schematic, Misc.	1-12
One-Spot Super	Schematic, Misc.	1-12
THE MAGNAVOX CO.		
One Dial	Schematic, Misc.	1-13
A	Schematic, Misc.	1-13
D	Schematic, Misc.	1-13
MAJOR LABORATORIES		
250 Amplifier	Schematic, Misc.	1-14
250 Amplifier, Power Unit	Schematic, Misc.	1-14
12	Schematic, Misc.	1-14
M-210 Amplifier	Schematic, Misc.	1-14
MCMILLAN RADIO CO.		
8 (2 Types) AC	Schematic, socket, voltage	1-1
Series 900	Schematic, socket, voltage	1-2
MONTGOMERY-WARD & CO.		
62-20, 62-26 (62-25)	Chassis layout, servicing data	2-23
62-20, 62-26 (62-25)	Schematic, voltage	2-24
62-030, 62-282, Troubadour	Schematic, socket, voltage, notes	2-1
62-040, Commodore, 62-181, Sovereign	Schematic, socket, voltage, notes	2-2
62-055, 49, 1522, 1922, 1562	Schematic, socket, voltage, chassis, data	1-1
62-055, 49, 1522, 1562 1922	Chassis wiring	2-3
62-11, 62-12, 62-14, 62-27, 62-19 (1st Type)	Schematic, voltage, notes	2-4
62-11, 62-12, 62-14, 62-27	Chassis layout, servicing data	2-5
62-11, 62-14, 62-9, 62-27 (2nd Type)	Schematic, notes	2-6
62-070, Princess, 62-060, Challenger, Jr. (1800)	Schematic, socket, voltage, notes	2-7
500, Dictator, 10,000 Serenader	Chassis wiring	2-8
500, Dictator, 10,000 Serenader	Schematic, socket, voltage, notes	2-9
921, 923, 924, 839 (Radiola 21, 22)	Schematic, socket, notes	2-11
921, 923, 924, 839 (Radiola 21, 22)	Conversion data, battery wiring	2-10
1111 (62-1611) Fantasy, 811 (62-1711) Solo	Voltage, socket, parts list, notes	2-12
1111 (62-1611) Fantasy, 811 (62-1711) Solo	Schematic, chassis wiring	2-13
1238 (62-1838)	Schematic, chassis layout, voltage, data	2-14
1855 (62-1955) Minstrel	Schematic, voltage, notes	2-15
1855 (62-1955) Minstrel	Chassis layout, servicing data	2-16
1500 (27-W, 15,000) Collegian	Schematic, servicing data	2-17
2655, AE-10	Voltage, socket, data	2-18
2655, AE-10 (1st and 2nd Types)	Schematic, socket	2-19
2822, 2827, Balboa, 2895, 2897 DeSoto	Schematic, socket, voltage, data	2-20
11,000, Challenger (2 Types)	Schematic, socket, voltage	2-21
14,000 Commander, 62,000 Cavalier	Schematic, socket, voltage, notes	2-22
WILLIAM J. MURDOCK CO.		
Neutrodyne, 3 Control	Schematic, Misc.	1-15
7-Tube, Single Control	Schematic, socket, Misc.	1-15
NATIONAL CARBON CO.		
1, 2, 3	Schematic, socket	1-1
20, 21	Schematic, socket	1-1
31, 32, 33, 34	Schematic, socket, voltage, parts list	1-2
42, 43, 44	Schematic, socket, voltage, parts list	1-3
52, 53, 54	Schematic, socket, voltage, parts list	1-4
THE NATIONAL COMPANY		
S-G 5	Schematic	1-1
S-G SW Tuner	Schematic	1-1
S-G SW Tuner with '71	Schematic	1-1
Auto Box Connections	Wiring diagram	1-1
MB-29	Schematic	1-2
MB-80	Schematic, chassis	1-2
Thrill Box AC, SW	Schematic	1-2
Auto Box	Schematic	1-2
NORDEN-HAUCK, INC.		
Super DX-5	Schematic	1-1
Super-DX-5A	Schematic	1-1
Admiralty Super 12	Schematic	1-2
C-7	Schematic	1-3
Super 10	Schematic	1-3
OPERADIO CORP.		
1925	Schematic, Misc.	1-16
1926	Schematic, Misc.	1-16
7	Schematic, Misc.	1-16

OZARKA, INC.		PAGE
MODEL		
Viking 5-A	Schematic	2-1
S-5	Schematic	2-1
S-7	Schematic	2-1
78 Battery	Schematic, socket	2-2
89 AC	Schematic, socket, voltage	2-2
SW-Converter	Schematic, chassis views	2-3
Viking 90 AC	Schematic, chassis, socket, voltage	1-2
91 Battery	Schematic, chassis	1-1
91 AC	Schematic, socket, chassis, voltage	2-4
92 AC	Schematic, socket, voltage, chassis	2-5
93 Battery, Superheterodyne	Schematic, socket, voltage	2-6
93-A	Schematic, chassis	2-7
93-B	Schematic, socket, voltage	2-5
94-AVC	Schematic, socket, voltage	2-9
PHILCO RADIO & TELEVISION CORP.		
B-253 Power Unit	Schematic, data	1-1
B-603 Power Unit	Schematic, data	1-1
180-B Power Unit	Schematic	1-2
B Part of AB Unit	Chassis layout	1-2
AB-425, AB-463, AB-623, AB-663	Schematics and layouts of power units	1-3
DB, AB-463, AB-623, AB-663	Specifications	1-4
8 Transistone	Schematic, compensating data, parts list	1-5
4 SW Converter	Chassis layout, parts list, data	2-1
4 SW Converter	Schematic, socket, voltage, data	2-2
20, 20-A	Schematic, chassis view	1-6
20, 20-A	Voltage, socket, values	2-3
20, 20-A	Circuit changes, chassis view	2-4
30	Schematic, socket, chassis view	1-7
30	Voltage, values, data	2-5
Coils, Compensating	Values, coding	2-6
Condensers	Schematic, voltage, data	1-8
35	Chassis, data	1-9
35	Test data	2-7
35	Schematic, voltage, data	1-10
40 DC	Schematic, socket, voltage, data	1-11
41 DC, 42 DC	Chassis, data	2-8
41 DC, 42 DC	Chassis, voltage, parts list	1-12
46, 46-E DC	Schematic, voltage, data	1-13
46, 46-E DC	Schematic, chassis, data	1-14
50, 50-A	Voltage, values	1-15
50, 50-A	Adjustments, parts list	2-9
50, 50-A	Test data	2-10
51, 51-A	Schematic, socket, data	2-11
51, 51-A	Voltage, data	2-12
51, 51-A	Chassis, adjustment, parts list, notes	2-13
Standard Bypass Condensers	Data	2-14
65	Schematic, socket, voltage	2-18
70, 70-A (Below #B-22,000)	Schematic, socket, voltage, data	1-16
70, 70-A	Chassis, parts values	1-17
70, 70-A	Parts list, data	2-15
70, 70-A	Chassis layout	2-16
77, 77-A	Schematic, socket, voltage, data	2-19
82, 86	Schematic, socket, data	1-20
87	Schematic, socket, voltage	1-21
87	Schematic, socket	2-21
Superheterodynes	Voltage, data	2-20
90, 90-A (with two '45s)	Adjustment notes	2-17
90, 90-A (with two '45s)	Chassis layout, parts values, data	2-27
90, 90-A (with two '45s)	Schematic, socket, voltage	2-23
90, 90-A (with one '47)	Parts list, data	2-24
90, 90-A (with one '47)	Schematic, socket, voltage	2-26
90, 90-A (with one '47)	Chassis layout, parts values, data	2-27
90, 90-A (with one '47)	Socket, test data	2-28
90, 90-A (with one '47)	Parts list	2-29
90, 90-A	Alignment data with Jewell 560	2-30
Condensers	Oscillator	2-30
95	Connections, color code	2-25
96, 96-A	Schematic, socket, voltage, data	1-23
96, 96-A	Schematic, socket	1-24
111, 111-A	Chassis	2-31
111, 111-A	Voltage, values, data	2-32
111, 111-A	Schematic, socket, data	2-33
111, 111-A	Chassis	2-34
112, 112-A (Below #174,001)	Voltage, parts values	1-25
112, 112-A	Schematic, socket	1-26
112, 112-A	Parts list	2-35
112, 112-A (Above and Below #174,001)	Chassis layouts	2-36
112, 112-A (Above #174,001)	Alignment notes	2-37
211, 211-A	Parts values, voltage	2-38
212, 212-A Radio	Schematic, socket, parts list	2-39
212, 212-A Radio	Schematic, socket, data	1-27
270, 270-A	Schematic	1-26
270, 270-A	Schematic, data	1-23
296, 296-A	Schematic, socket, data	1-30
470, 470-A	Schematic, socket, chassis	2-40
470, 470-A	Voltage, parts values	2-41
470, 470-A	Parts list	2-42
490	Schematic, socket, voltage	2-43
490	Chassis layouts, data	2-44
490	Parts list	2-45
500 Series	Schematic, chassis wiring	1-29
PILOT RADIO & TUBE CORP.		
171 Power Amplifier	Schematic	1-1
Public-Address System	Schematic	1-1
K-111 ABC Pack	Schematic	1-2
Pilotone B Pack	Schematic	1-2
ABC Pack for SP5	Schematic	1-2
Jumbo Power Pack	Schematic	1-2
Jumbo ABC	Schematic	1-2
Air Hound (All Electric)	Schematic	1-3

PILOT—Continued

MODEL		PAGE
Air Scout (All Electric)	Schematic	1-3
Pilotone (Electric)	Schematic, socket	1-3
K-110, Super-Wasp, Battery	Schematic, socket	1-4
K-115, AC Super-Wasp	Schematic, socket	1-4
K-117, Twin Screen-Grid 8	Schematic	1-4
K-121, K-121X, Country Special	Schematic, socket	1-5
PE-6 SG, K-122, K-123, K-124	Schematic, socket	1-5
K-126, K-128	Schematic, socket	1-5
K-136 AC Universal	Chassis wiring, two views	2-2
K-139 Power Pack	Schematic	2-1
140 Auto Set	Schematic, socket, wiring, data	1-6
S-141	Schematic	2-1
Dual-Wave Midget (200-2,000 Meters)	Schematic	2-1
S-W Converter	Schematic	1-6
C-153, C-154 (with two '45s)	Schematic, socket	2-3
C-153, C-154 (with two '47s)	Schematic, socket	2-4
V-191	Schematic, socket	2-4
AC Midget, S-155, S-155-A, S-155-B, S-155-F, C-157, C-157-A, C-157-B, C-157-F (2 Types)	Schematic, socket	1-7
DC Midget, S-156, S-158	Schematic, socket, data	2-5

RCA-VICTOR CO., INC.

AP-736	Schematic	1-1
AP-736-B	Schematic, chassis wiring	1-1
AP-777-C	Schematic	1-2
AP-935	Schematic	1-3
AP-937	Schematic	1-3
AP-947	Schematic	1-2
AP-951	Schematic	1-2
AP-951-A, 974-A, AP-997-A	Schematic	1-2
AP-995	Schematic	1-4
AP-997, AP-952	Schematic	1-4
AP-997-C	Schematic	1-4
AP-1080	Schematic	1-3
12-25 Tuscany 8-60	Socket layout	1-4
Radiola Grand	Socket layout	1-4
Radiola Senior	Schematic, socket	1-5
Radiola AR	Schematic, socket	1-5
Radiola RS	Schematic, socket	1-5
Radiola II	Schematic, socket	1-6
Radiola III	Schematic, socket	1-6
Radiola Balanced Amplifier	Schematic, socket	1-6
Radiola Senior Amplifier	Schematic, socket	1-6
Radiola III-A	Schematic, socket	1-7
Radiola IV	Schematic, socket	1-7
Radiola V	Schematic, socket	1-7
Radiola VI	Schematic, socket	1-7
Radiola VII	Schematic, socket	1-8
Radiola VII-B	Schematic, socket	1-8
Radiola Super VIII	Schematic, socket, data	1-9
Radiola IX	Schematic, socket	1-8
R-4, R-6	Chassis wiring, voltage, data	2-1
R-4, R-6	Schematic, parts list	2-2
R-4, R-6	Test data	2-3
R-5, AC	Parts list, notes	1-10
R-5, AC	Schematic, chassis wiring, voltage	1-11
R-5	Test data, voltage	2-5
R-5-X	Schematic, chassis wiring, voltage	2-4
R-5-X	Parts list, socket, notes	2-6
R-5-X	Test data, voltage	2-5
R-7, R-9, AC Superette	Chassis wiring	1-12
R-7, R-9, AC Superette	Schematic, voltage, service notes	1-13
R-7, R-9, AC Superette	Resistance data, socket	2-7
R-7, R-9, DC Superette	Schematic, socket, voltage, data	2-8
R-7, R-9, DC Superette	Chassis wiring, parts list	2-9
R-7, R-9, DC Superette	Resistance data, voltage, socket	2-10
R-7-A AC	Schematic, chassis wiring, voltage	2-11
R-7-A AC	Resistance data, voltage, socket	2-12
R-8, R-12, AC	Schematic, socket, voltage	2-13
R-8, R-12, AC	Chassis wiring, parts list	2-14
R-8, R-12, AC	Resistance data, socket, voltage	2-15
R-10 AC	Schematic, chassis wiring, voltage, data	2-16
R-10 AC	Resistance data, socket, voltage	2-17
R-11 AC, Early	Schematic, socket, voltage	2-18
R-11 AC, Early	Chassis wiring, data	2-19
R-11 AC, Late	Chassis wiring	2-20
R-11 AC	Parts list, notes	2-21
R-11 AC	Resistance data, socket, voltage	2-22
R-15	Schematic, socket, voltage, data	1-14
Radiola 16	Schematic, socket, data	1-15
Radiola 17	Schematic, socket, voltage, data	1-15
Radiola 18 DC	Schematic, socket, voltage	1-16
Radiola 18 AC	Schematic, socket	1-16
RE-18	Schematic, socket, data	2-23
RE-18	Assembly wiring	2-24
RE-18	Resistance data, socket, voltage	2-25
RE-18-A	Parts list, specifications	2-26
RE-18-A	Parts list concluded	2-27
RE-19 AC (AVC)	Schematic, socket, chassis wiring, data	2-28
RE-19 AC (AVC)	Assembly wiring, parts list	2-29
Radiola 20	Schematic, socket, data	1-17
RE-20 Electrola	Chassis wiring, parts list	2-30
RE-20 Electrola SPU	Chassis wiring, parts list	2-33
RE-20 Electrola	Schematic, socket, data	2-31
RE-20 Electrola	Assembly wiring, parts list	2-32
Radiola 21, 22	Schematic, socket, voltage	1-18
R-21	Schematic, changes, parts list	2-34
R-21	Chassis wiring, parts list	2-35
R-21	Resistance data, socket, voltage	2-36
RO-23	Schematic, socket	2-37
RO-23	Chassis wiring, data	2-38
RO-23	Converter chassis wiring, data	2-39
RO-23	Alignment notes	2-40
RO-23	Assembly wiring, voltage, notes	2-41

MODEL		PAGE
RO-23	Parts list	2-42
Radiola 24	Schematic, socket	1-19
Radiola 25	Schematic, socket, wiring	1-20
Radiola 25 (104 Power Pack)	Schematic, voltage	1-21
Radiola 26	Schematic, socket	1-19
RAE-26	Assembly wiring	2-43
RAE-26	Schematic, socket, data	2-44
RAE-26	Resistance data, socket, voltage	2-45
Radiola 28 Battery	Schematic, wiring	1-22
Radiola 28 AC (104 SPU)	Schematic, socket	1-23
Radiola 30 AC (104 SPU)	Schematic, wiring, data	1-24
Radiola 30-A	Schematic, socket, voltage	1-25
Radiola 30-A Power Pack	Schematic	1-25
M-30 Auto Radio	Schematic, socket	2-46
M-30	Chassis wiring	2-47
M-30	Notes, Part 1	2-48
M-30	Notes, Part 2	2-49
M-30	Notes, Part 3	2-50
M-30	Notes, Part 4	2-51
M-30	Notes, Part 5	2-52
M-30	Notes, Part 6	2-53
M-30	Notes, Part 7	2-54
M-30	Notes, Part 8, wiring, Notes, Part 9	2-55
M-30	Parts list	2-56
M-30	Resistance data, voltage, socket	2-58
P-31, Portable	Schematic, chassis, socket, voltage	2-59
P-31, Portable	Chassis wiring, data	2-60
Victor R-32, RE-45, R-52	Schematic, socket, voltage, data	1-26
Radiola 32 AC	Schematic, socket, data	1-27
M-32 Auto Radio	Notes, Part 1	2-61
M-32	Notes, Part 2	2-62
M-32	Notes, Part 3	2-63
M-32	Notes, Part 4	2-64
M-32 Battery-Operated	Terminal data	2-65
M-32	Service data, voltage	2-66
M-32	Chassis wiring	2-67
M-32	Schematic, control box wiring	2-68
M-32	Parts list	2-69
Radiola 33 AC	Schematic, socket, voltage	1-28
Radiola 33 DC	Schematic, socket	1-28
Victor R-35, R-39, RE-57	AF chassis wiring, socket, voltage, data	1-29
Victor R-35, R-39, RE-57	Schematic, data	1-30
Radiola 41 DC, AF and SPU	Chassis wiring, voltage	1-31
Radiola 41 AC RF	Schematic, socket, data	1-32
Sterling SPU	Schematic, voltage	1-32
Receptor SPU	Schematic, voltage	1-32
Radiola 42	Schematic, notes	1-34
R-43	Schematic, socket, voltage, chassis wiring	1-33
R-43	Service notes	1-34
Radiola 44 AC	Terminal voltage	1-35
Radiola 46 DC	Schematic	1-35
Radiola 46 AC	Terminal voltage	1-35
44, 46 RF Chassis	Schematic, socket, voltage	1-36
44, Early SPU	Schematic	1-36
44, Late SPU	Schematic	1-36
46, SPU	Schematic	1-36
Radiola 47	Schematic, socket, voltage	1-37
Radiola 48	Schematic, socket, voltage, data	1-38
Radiola 48	Resistance data, voltage, chassis	2-70
R-50, R-55	Schematic, chassis wiring	2-71
R-50, R-55	Chassis layouts, voltage, socket, notes	2-72
RAE-59	Schematic, socket, data	2-73
RAE-59	Assembly wiring	2-74
Radiola 60	Schematic, socket, voltage, data	1-39
Radiola 62	Schematic, socket, voltage, data	1-40
Radiola 64	Schematic, socket, voltage, data	1-41
Radiola 66	Schematic, socket, voltage, data	1-42
Radiola 67	Schematic, data	1-43
RE-75	Assembly wiring, data	2-75
RE-75	Parts list	2-76
RE-75	Locations of parts	2-77
RE-75	Notes, Part 1	2-79
RE-75	Notes, Part 2	2-80
RE-75	Notes, Part 3	2-81
RE-75	Notes, Part 4	2-82
RE-75	Realignment data	2-78
Tuning Condensers	Schematic, socket, data	2-83
RAE-79	Receiver chassis wiring, data	2-84
RAE-79	Assembly wiring	2-85
RAE-79	Remote control notes	2-86
RAE-79	Motor adjustments	2-87
RAE-79, SPU-1, SPU-2	Chassis wiring diagrams	2-88
Radiola 80	Schematic, socket, voltage	1-44
Radiola 80	Trimmers, chassis wiring of SPU	2-89
Radiola 80	Assembly wiring	2-90
Radiola 80	Resistance data	2-91
Radiola 82	Schematic, socket	1-45
Radiola 82	Chassis wiring	2-92
Radiola 82 SPU	Chassis wiring	2-93
Radiola 82	Resistance data, socket, voltage	2-94
Radiola 82 (Remote Control)	Schematic, notes	1-47
Radiola 82 and 86 (Remote Control)	Assembly wiring	1-46
Radiola 82 and 86 (Remote Control)	Receiver chassis wiring	1-48
Radiola 82 and 86 (Remote Control)	SPU chassis wiring	1-49
Radiola 82 and 86 (Remote Control)	Remote control units, data	1-50
Radiola 86 AF Circuits	Schematics	1-51
Radiola 86	Schematic, data	1-52
Radiola 86	Assembly wiring	2-95
SW Adaptor, SW-10	Schematic, chassis wiring	1-53
SW-10	Voltage, chassis views, data	1-54
SWA-2, SW Converter	Chassis wiring, parts list, data	2-96
SWA-2, SW Converter	Schematic, data, tuning chart	2-97
100-A, 100-B, 103, 104-AC 105, 106	Schematic, socket, data	1-55
Victor Alhambra I (7-1)	Schematic, socket, wiring	1-56
Victor Alhambra I (7-1)	Schematic, socket	1-57

RCA-VICTOR—Continued		PAGE
MODEL		
Victor Alhambra II, Florenza	Schematic, socket	1-57
Victor Borgia I	Schematic, socket	1-58
Victor Electrola Hyperion	Schematic, socket	1-58
2-25 Portable Victrola	Parts list, assembly	2-98
2-25 Portable Victrola	Notes	2-99
2-65 Turntable	Notes	2-100
Victor 7-10, Radiola 16	Schematic, socket	1-59
Victor 7-11, Radiola 18	Schematic, socket, voltage	1-59
Victor 7-25, Radiola 17	Schematic, socket	1-59
Victor Borgia II	Schematic, socket	1-60
Victor Tuscany	Schematic, socket	1-60
Victor Cromwell, 12-1	Schematic, socket	1-61
Victor 12-15	Schematic, socket	1-61
Victor 12-15-C	Schematic, socket	1-61
Victor E-35	Cable Wiring	1-61
Victor 7-3, 7-30, R-20	Schematic, socket	1-62
Victor 7-25	Schematic, socket	1-62
Victor 8-60	Schematic, socket	1-63
Victor 9-15	Schematic, socket	1-63
Victor 9-18	Schematic, socket, voltage	1-64
Victor 9-25	Schematic, socket	1-65
Victor 9-40	Schematic	1-65
Victor 9-54	Schematic, socket, voltage	1-66
Victor 10-51-A	Schematic, socket	1-67
Victor 9-55	Schematic, socket	1-67
Victor 10-69	Schematic, socket, chassis wiring	1-68
Victor 10-70	Schematic, socket	1-69
Victor 10-70-A	Schematic, socket	1-69
Victor 12-25	Schematic, socket	1-69
Theremin	Schematic, data	1-70
Photophone PG-32	Schematic	2-101
Photophone PG-32	Change-over panel wiring	2-102
Photophone PG-32	Voltage, exciter-lamp chassis wiring	2-103
Photophone PG-32, Voltage Amplifier	Panel wiring	2-104
Photophone PG-33	Schematic	2-105
Photophone PG-33	Chassis wiring, voltage	2-106
Photophone PK-25	Schematic, chassis wiring	2-107
Photophone SPU 62	Schematic, chassis	1-71
Photophone SPU 63	Schematic	1-71
Photophone SPU 206	Schematic	1-71
Detector and Amplifier Tubes	Characteristics	2-108
Power Amplifiers, Rectifiers, Photo Tubes	Characteristics	2-109
RADIART LABORATORIES		
Magnaformer 918	Schematic, Misc.	1-4
RADIO RECEPTOR CO.		
PMA-1	Schematic	2-1
P-50-W	Schematic	2-1
RADOLEK		
Monroe-Marvelo 80	Schematic	2-1
Marvelo 6 Midget	Schematic	2-1
Radolek 5-Tube Super	Schematic	2-1
RADIO PRODUCTS CO.		
Dayrad 8-80	Schematic	1-1
Dayrad 21 Output Meter	Schematic	1-2
330-Mmf. Oscillator	Schematic	1-2
Dayrad 180	Schematic	1-3
Dayrad HR	Schematic	1-3
Dayrad 870 Test Meter	Schematic	1-3
Dayrad 875	Schematic	1-3
RADIOTROPE		
74-R	Schematic, socket, voltage	1-1
27-R, Early and Late	Schematic, socket, voltage	1-2
READRITE METER WORKS		
400 Tube Tester	Schematic	2-1
405 Tube Checker	Schematic	2-1
550 Oscillator	Schematic	2-2
600, 700 Testers	Schematic	2-2
800 Capacity Meter	Schematic	2-2
850 Capacity Meter	Schematic	2-2
REMLER CO., LTD.		
1927 Infradyne	Schematic	2-1
1928 Infradyne	Schematic	2-1
Remler 40 KC.	Schematic	2-1
10-3	Schematic, socket, voltage	2-2
14	Schematic, socket, chassis, voltage, data	1-1
15-3	Schematic, voltage, data	2-2
Best 115 KC.	Schematic	1-2
Remler 29	Schematic	1-2
SAMSON ELECTRIC CO.		
PAM-1	Schematic	2-1
PABC-2	Schematic	2-2
PABC-3	Schematic	2-2
PAM-3	Schematic	2-2
PAM-5	Schematic	2-3
PAM-5-D	Schematic	2-3
PABC-4	Schematic	1-3
PABC-5	Schematic	1-3
Amplifier	Schematic	1-1
PAM-8, 18	Schematic	2-4
PAM-9	Schematic	2-4
PAM-11, 12, 13, 14	Schematic	2-5
PAM-16, 17	Schematic	2-6
PAM-16-N, 17-N	Schematic	2-6
PAM-19	Schematic	1-1
PAM-19-N	Schematic	2-7
PAM-19-Q	Schematic	2-7
PAM-22	Schematic	2-8
PAM-23	Schematic	2-9
PAM-24	Schematic	2-9
PAM-25	Schematic	2-9

	PAGE
MODEL	
PAM-25-D	Schematic
PAM-29	Schematic
PAM-39	Schematic
PAM-45	Schematic
PAM-48	Schematic
PAM-59	Schematic
S-100	Schematic
MIK-1	Schematic
MIK-1-D	Schematic
HA-2	Schematic
MIK-80	Schematic
PAM-80	Schematic
SCOTT TRANSFORMER CO.	
World Record 10	Schematic
Shield Grid 9	Schematic
All-Wave Super Receiver	Schematic
All-Wave Super Receiver	Chassis wiring
All-Wave Super 145	
Power Pack	Schematic, chassis wiring
All-Wave Super 150	Chassis views, schematic, control box
Power Pack	
SEARS-ROEBUCK & CO.	
1150	Schematic
1150	Voltage, socket, data
1152, 1420	Schematic, socket
1152, 1420	Chassis wiring, voltage
1250	Schematic, socket
1252	Chassis wiring, voltage
1252	Schematic, socket, data
1260	Schematic
1290, 1800	Chassis wiring
1290, 1300, 1292, 1302	Schematic, socket, data
1292, 1302	Chassis wiring
1310, 1312	Schematic, socket
1310, 1312	Voltage, data
1320, 1322, 1324, 1450	Schematic, socket, voltage
1320, 1322, 1324	Chassis wiring
1370	Schematic, socket, voltage
1390, 1400, 1402, 1404, 1406	Schematic, socket, voltage, data
1430	Voltage, data
1430	Schematic, socket
Silvertone 218	Schematic, socket, voltage
1462	Schematic, socket
1462	Voltage
1480, 1482, 1484	Voltage
1480, 1482, 1484	Schematic
SENTINEL RADIO CORP.	
11, 12, 15, 16 (104)	Schematic, socket, voltage, parts values
31, 33	Schematic
106-B	Schematic
108	Schematic, socket
108-A, 110	Schematic, socket
108-A, 110	Voltage, alignment data
109	Schematic, voltage, data
111	Schematic, socket, voltage, data
114	Voltage, chassis, data
114	Schematic, socket
440	Schematic
444	Schematic, socket, voltage
518	Schematic
550	Schematic
614	Schematic
660	Schematic
666-C	Schematic, socket
1020, 1030	Schematic, chassis wiring
SILVER-MARSHALL, INC.	
80	Schematic, socket, voltage
440, Time Signal Amplifier	Schematic
80-B, 60-B, 75-B, 90-B	Schematic, socket, voltage
80, Circuit B	Schematic, data
80, Circuit C	Schematic, data
80, Circuit D	Schematic, data
80, Circuit E	Schematic, data
83-A Power Supply, 25 and 60 Cycles	Schematic, socket, voltage
84-A	Schematic, socket
85-A	Schematic, socket
86-A	Schematic, socket, voltage
Bearcat, 87, 88, 89, 782 Midget	Schematic, voltage
SM-651 Power Pack	Schematic
SM-660 Unipack	Schematic
SM-660-B (Without Push-pull)	Schematic
SM-650-B	Schematic
SM-652	Schematic
SM-669	Schematic, chassis wiring
670-ABC	Schematic, chassis wiring
670-B	Schematic, chassis wiring
675	Schematic, chassis wiring, parts list
677, 25 and 60 Cycles	Schematics, chassis wiring
677-B	Schematic, voltage
678-PD	Schematic, chassis wiring
679	Schematic
683	Schematic, socket, data
684	Schematic
685	Schematic
690	Schematic
692	Schematic
710, Sargent Raymond 7	Schematic, chassis view, data
712	Schematic, socket, chassis view
714	Schematic, socket, voltage, chassis views
716	Schematic, socket, data
720 AC	Schematic
720 Battery	Schematic, chassis view
722 AC	Schematic, socket, voltage, data
722DC	Schematic, chassis wiring
724 AC	Schematic, socket, voltage, chassis view
724 DC	Schematic, socket
Long-Wave Receiver	Schematic

SILVER-MARSHALL—Continued

MODEL	PAGE
726	Schematic, socket, voltage, parts list1-24
727 SW-ALL Wave	Parts list2-3
727 SW-ALL Wave	Schematic, socket, data.....2-4
730, 731	Schematic1-25
735 AC	Schematic1-25
735 DC	Schematic, socket1-26
737 AC Bearcat	Schematic, socket1-26
738 AC SW Converter	Schematic, socket1-26
739 SW Superhet Converter	Schematic, data1-27
740 DC	Schematic, chassis1-28
740 AC	Schematic1-28
770 Auto	Schematic, socket, chassis view.....1-29
773, Broadcast-Long Wave	Schematic, data2-5
A	Schematic, socket1-30
B	Schematic, socket, data.....2-5
C	Schematic, socket2-7
C	Parts list2-8
D, E	Schematic, socket, voltage.....1-31
F	Schematic, socket1-30
G	Schematic, socket2-9
J	Schematic, socket2-10
Q DeLuxe	Parts list2-11
Q DeLuxe	Schematic, socket2-12
R	Parts list2-13
R	Schematic, socket2-14
S-C II	Schematic1-32
620 S-C	Schematic1-32
635 Kit	Schematic1-32
642 AC Tuner	Schematic1-32

SILVERTONE

See SEARS-ROEBUCK CO.

SIMPLEX RADIO CO.

D	Schematic, socket1-1
F	Schematic1-2
G	Schematic1-1
6-A	Schematic, socket1-2
N DC	Schematic, socket2-1
P AC	Schematic, socket2-2
P Battery	Schematic, socket2-2
P 1931	Schematic2-3
Q 1931	Schematic, socket2-3
R AC	Schematic, socket2-1

M. B. SLEEPER

RX-1	Schematic, Misc1-13
------	---------------------------

SONORA PHONOGRAPH CO.

3R, 4R	Schematic1-1
5R	Schematic1-2
7P	Schematic1-3
A-30, A-32	Schematic1-4
A-30, A-32	Socket, voltage, chassis wiring.....1-5
B-31, 25 Cycles	Schematic, socket1-6
A-36, A-46	Schematic, socket, voltage.....1-7
A-40	Schematic1-8
A-40	Chassis wiring, socket, voltage.....1-9
DeLuxe 44	Schematic, voltage1-10
2-M Automatic Stop	Schematic, parts details.....1-11
2-RP, 25 Cycles	Schematic1-12

SONORA

71, 72, 73	Schematic2-1
84, 85	Voltage, chassis layout, data.....2-2
84, 85	Schematic, data2-3
86, 87	Voltage, data2-4
86, 87	Schematic, chassis, data.....2-5

SPARKS WITHINGTON CO.

5, 9	Schematic, chassis layout, data, voltage2-1
9-A	Schematic, socket, voltage.....2-2
5-15, 5-26	Schematic1-3
6-15, 6-26	Schematic1-3
10	Chassis, voltage, data.....2-3
10	Schematic2-4
12	Schematic, chassis, voltage.....2-5
14	Voltage, chassis, data.....2-6
14	Schematic2-7
15	Chassis, voltage, data.....2-8
15	Schematic2-9
16-AW, 26-AW, SW Receiver	Schematic, voltage2-10
16, 16-AW	Schematic, voltage2-11
AR-19	Schematic1-1
AR-19	Chassis views2-12
25, 26	Schematic2-14
25, 26	Chassis, voltage2-15
26-AW, Revised #2	Schematic2-16
30	Chassis, voltage2-17
30	Schematic2-18
30	Service data, Part 1.....2-19
30	Service data, Part 2.....2-20
30	Parts list2-21
30	Chassis views2-22
31, 32	Schematic1-4
31, 32	Chassis views2-23
35	Service data2-24
35	Service data, continued.....2-25
35	Service data, concluded.....2-26
35	Chassis views2-27
Carbon Resistors	Values, color coding.....2-28
Carbon, Wire-Wound Resistors	Values, types, color coding, etc.2-29
39	Schematic1-4
40	Schematic, voltage, socket.....2-30
41	Schematic, socket, voltage.....2-31
45	Schematic2-32
45	Chassis, voltage, data.....2-33
49	Schematic1-5
AR-50	Schematic1-1
AR-50	Chassis2-12
51, 52	Schematic, socket, voltage.....2-34
51, 52	Service data2-35
55 AC, Police Desk	Schematic2-36

MODEL

56	Schematic2-37
56	Voltage, chassis, data.....2-38
60 SW Converter	Schematic, socket, voltage.....2-39
AC-7, 62, 63	Schematic, socket, voltage.....1-5
69, 79-A, 89	Schematic, voltage1-7
89-A	Schematic, voltage1-7
99	Ensemble wiring1-10
99	Schematic1-11
103, 573	Assembly wiring, voltage, chassis2-40
103, 573	Schematic2-41
Antenna Trimmer	Service Notes2-42
109 DeLuxe	Schematic1-12
110, 111 AC (2 Types)	Schematic1-13
111-A, 574, 870	Schematic2-43
235	Schematic2-44
301 AC	Schematic, voltage1-14
301 DC	Schematic, voltage2-45
420 AC	Chassis layout2-46
420 AC	Schematic2-47
420 DC	Chassis layout2-48
420 DC	Schematic2-49
564, 570, 740, 750 AC	Schematic, voltage2-50
Resistors	Standard Color Coding.....2-51
589 AC	Schematic, voltage1-19
591, 593 AC	Schematic2-52
DC 564, 570, 600, 610, 620, 740, 750	Schematic2-53
600, 610, 620, 737 (Below \$6502)	Schematic, voltage.....2-54
737 AC (Above \$6502)	Schematic2-55
Power Converters	Chassis views2-56
Selector Unit	Chassis views2-57
Amplifier and Connector Units	Chassis views2-58
Power Converters	Chassis views2-59
Tubes	Characteristics and data.....2-60
930 AC	Schematic, voltage1-21
931 AC	Schematic, voltage1-22
931 DC	Schematic1-22

MODEL	PAGE
Schematic2-37
Voltage, chassis, data2-38
Schematic, socket, voltage2-39
Schematic, socket, voltage1-5
Schematic, voltage1-7
Schematic, voltage1-7
Ensemble wiring1-10
Schematic1-11
Assembly wiring, voltage, chassis2-40
Schematic2-41
Service Notes2-42
Schematic1-12
Schematic1-13
Schematic2-43
Schematic2-44
Schematic, voltage1-14
Schematic, voltage2-45
Chassis layout2-46
Schematic2-47
Chassis layout2-48
Schematic2-49
Schematic, voltage2-50
Standard Color Coding2-51
Schematic, voltage1-19
Schematic2-52
Schematic2-53
Schematic, voltage2-54
Schematic2-55
Chassis views2-56
Chassis views2-57
Chassis views2-58
Chassis views2-59
Characteristics and data2-60
Schematic, voltage1-21
Schematic, voltage1-22
Schematic1-22

SPARTON

See SPARKS WITHINGTON CO.

SPLITDORF ELECTRIC MFG. CO.

See THOMAS A. EDISON, INC.

STANDARD RADIO CORP.

Standardyne 29 AC	Schematic, socket, Misc.....1-19
-------------------	----------------------------------

STEINITE RADIO CO.

40, 40-A, 50, 50-A, 102	Schematic1-1
102-A	Schematic, socket, voltage.....1-2
40-C, 60-C, 102-C	Schematic, socket, voltage.....1-2
40, 45, 40-A, 45-A, 50-A, 102 SPU	Schematic, socket, chassis wiring1-3
70, 80, 95 (Chassis #10)	Schematic, socket, chassis wiring1-3
203, 600, 605, 630, 635, 642, 643 (Chassis #22)	Schematic2-1
261, 262, 263, 264, 265	Schematic, socket, voltage.....1-4
420, 450 (Chassis #15)	Schematic, socket2-3
420, 450 (Chassis #17)	Schematic, socket2-2
421, 425 (Chassis #21)	Chassis layout, data.....2-4
421, 425 (Chassis #21)	Schematic2-5
423 (Chassis #23)	Schematic2-6
700, 705, 706, 725, 642-B (Chassis #26)	Schematic2-7
700, 705, 706, 725, 642-B (Chassis #26)	Voltage, data2-8
700, 701 (Chassis #28)	Schematic, data, voltage.....2-9
990, 991, 992, 993	Schematic, socket, voltage.....1-5

STENODE RADIOSTAT

Stenode Radiostat	Schematic, Misc.1-18
-------------------	---------------------------

STERLING MFG. CO.

3-A	Schematic1-1
4	Schematic1-2
Miniature	Schematic, voltage1-3
Miniature	Chassis views, data.....1-4
F	Schematic1-5
8-Tube Receiver	Schematic1-5
R-100 MV	Schematic2-1
R-402	Schematic2-1
R-403	Schematic2-1
R-404	Schematic2-1
R-406	Schematic2-1
R-407	Schematic2-1
R-409	Schematic2-3
R-410	Schematic2-3
R-411	Schematic2-3
R-412	Schematic2-3
R-509	Schematic2-3
R-510	Schematic2-3
R-511	Schematic1-6
R-522	Schematic1-6
R-807-A	Schematic2-2
R-810 (1st Type)	Schematic2-2
R-810 (2nd Type)	Schematic2-2
R-880	Schematic2-2

STEWART-WARNER CORP.

R-100-A, B, E, AC	Schematic1-10
R-100 Series	Chassis wiring, voltage.....1-10
R-100-A	Continuity tests1-11
R-100-C DC	Schematic, socket, voltage.....1-12
R-101-A, R-101-B	Schematic, socket, voltage.....2-1
R-101, R-102	Chassis layout, servicing notes.2-2
R-101, R-102	Servicing notes, concluded.....2-3
102-A, B, E (1st Type)	Schematic, socket, voltage.....2-4
R-102-A, B and E (Revised)	Schematic, socket, voltage.....2-5
300, 305	Schematic, socket1-1
R-301-A, B, E, SW Converter	Schematic, servicing notes.....2-6
305, 315, 320	Schematic, socket1-1
310, 325	Schematic, socket1-1

STEWART-WARNER—Continued

MODEL		PAGE
330	Schematic, socket	1-1
335, 340	Schematic, socket	1-1
345, 350, 355, 360	Schematic, socket	1-1
385, 390	Schematic, socket	1-2
500, 520, 525	Schematic, socket	1-2
530, 535	Schematic, socket	1-2
530, 535, 715, 720 SPU	Schematic	1-2
700, 705, 710	Schematic, socket	1-3
715, 720	Schematic, socket	1-3
750	Schematic, socket	1-3
801, 802	Schematic, socket	1-4
801, 801-A, 811, 811-A	Schematic, socket, voltage	1-4
(Series B)	Schematic	1-4
PU 801, 801-A, 811, 811-A	Schematic, socket	1-5
806 (Series A)	Schematic, socket	1-5
806 (Series B)	Schematic, socket	1-5
950 Series Battery	Schematic, socket, voltage	1-5
950 Series AC	Schematic, socket, chassis	1-5
901, 902, 903, 911, 912, 913	Schematic, socket, voltage, chassis	1-7
950 Series DC	Schematic, socket	1-8
971, 972, 973 DC	Schematic	1-9
980 Battery	Schematic	1-9
Resistors	Variable and fixed, Part 1	1-13
Resistors	Fixed, Part 2	1-14
A-F. Transformers	Data	1-15

STORY & CLARK RADIO CORP.

36	Schematic, socket, chassis	1-1
43, 51	Schematic, socket	1-2

STROMBERG-CARLSON TEL. MFG. CO.

1-A	Schematic, socket	1-1
1-B	Schematic, socket	1-1
301-A	Schematic	1-3
501, 501-A, 501-B, 502, 502-A, 502-B	Schematic, socket	1-1
403-AA	Schematic, socket	1-2
403, 403-A	Schematic	1-3
403-B	Schematic	1-3
404-RA	Schematic, socket	1-11
523, 524 AC	Schematic, socket	1-2
601, 602	Schematic, socket	1-4
633, 634	Schematic, socket	1-4
635, 636 (2 Types)	Schematic, socket, voltage	1-5
638 AC	Chassis wiring	1-6
638 AC	Schematic, socket, voltage	1-7
638 DC	Schematic, socket	1-7
641, 642, 652, 654	Schematic, socket, voltage	1-8
641	Resistance data	2-21
642	Chassis wiring	1-9
645 DC	Chassis wiring	2-22
652, 654	Chassis wiring	1-10
734	Schematic, socket	1-11
744	Schematic, socket, voltage	1-12
846 AC	Schematic, socket, voltage	1-13
846	Internal wiring	2-23
346	Chassis, voltage, test data	2-23
10, 11	Schematic, socket, voltage	1-14
10, 11	Chassis wiring	1-15
10, 11	Voltage, socket, resistance data	2-1
12, 14	Schematic, socket, voltage	1-16
12, 14	Chassis wiring	1-17
Phonograph Pick-up	Schematic	1-16
Multiple-Record Phonograph	Chassis wiring	1-16
19, 20 AC	Schematic	1-18
19, 20 AC	Chassis wiring	1-19
19, 20 AC	Voltage, parts values	2-2
19, 20 AC	Chassis views	1-21
19, 20 AC	Test data	2-3
22, 22-A	Chassis wiring	2-4
22, 22-A	Schematic, socket	2-5
22, 22-A	Voltage, values	2-6
22, 22-A	Chassis views	2-7
25, 26 AC	Chassis wiring	2-8
25, 26 AC	Schematic, socket	2-9
25, 26 AC	Voltage	2-10
25, 26 AC	Condenser and resistor values	2-11
27 AC	Chassis wiring	2-12
27 AC	Schematic	2-13
27 AC	Voltage, parts list	2-14
29	Chassis wiring	2-15
29	Schematic, socket, data	2-16
29	Parts list, voltage	2-17
38, 39, 40 (1st Type)	Schematic, socket, data	2-18
38, 39, 40	Chassis wiring, data	2-19
38, 39, 40	Parts list, voltage	2-20

SUPREME INSTRUMENTS CORP.

19 Revised Tube Checker	Schematic	1-1
56 Analyzer (Weston Metered)	Schematic	2-3
90 Analyzer	Schematic	1-2
90 Analyzer (Weston Metered 6-J)	Schematic	2-3
Output Meter	Schematic	1-2
99-A Analyzer	Schematic	1-3
400-A Diagonometer	Schematic	1-4
400-B, #4 Series Diagonometer	Schematic	2-1
70 Oscillator	Schematic	1-6
AAA-1 (8-14-31) Diagonometer	Schematic	2-3

TEMPLE CORPORATION

8-6j, 8-80, 8-90	Schematic, socket, voltage	1-1
8-61, 8-81, 8-91	Schematic, socket, voltage	1-2

THORDARSON ELECTRIC MFG. CO.

R-171	Schematic, chassis wiring	1-1
PP-171	Schematic, chassis wiring	1-1
210 Power Amplifier	Schematic, chassis wiring	1-2
R-210	Schematic, chassis wiring	1-3
213	Schematic	1-3
Eliminator	Schematic	1-3
250 Power Amplifier	Schematic, chassis wiring	1-4

TODD ELECTRIC CO.

MODEL		PAGE
"A" Unit	Schematic, Misc.	1-18

TRANSFORMER CORP. OF AMERICA

40	Schematic, socket, voltage, chassis	1-1
40	Chassis data	1-2
51, 53, 55 AC	Chassis, socket, voltage	1-3
51, 53, 55 AC	Power pack chassis, receiver breakdown	1-4
AC-60, 25-60	Schematic, socket, voltage, data	1-5
AC-60, 25-60	Chassis, test data	1-6
AC-61, 25-61	Schematic, socket, data	1-7
AC-61	Chassis layout	1-8
AC-61	Voltage, data	1-9
AC 70	Schematic, voltage, data	1-7
AC 70	Chassis layout	1-8
AC 70	Voltage, data	1-9
AC-80, 81	Schematic, socket	1-10
AC-80, 81	Chassis layout	1-11
AC-80, 81	Voltage, breakdown analysis	1-12
AC-84, 85	Schematic, voltage	2-1
AC-84, 85	Chassis layout, speaker	2-2
AC-84, 85	Alignment data	2-3
AC-84, 85	Parts list	2-4
AC-90, 90-A, 91	Schematic, socket	1-10
AC-90, 90-A, 91	Chassis layouts	1-11
AC-90, 90-A, 91	Voltage, breakdown analysis	1-12
AC-94, 95	Speaker	2-2
AC-94, 95	Alignment data	2-3
AC-94, 25-94	Schematic, voltage	2-5
AC-94, 25-94	Chassis layouts, socket, test data	2-6
AC 100 Series	Schematic, socket, voltage	2-7
AC 100 Series	Chassis layout, speaker data, test data	2-8
AC 100 Series	Trimmer notes	2-9
AC 100 Series	Parts list, test data	2-10
120-139	Schematic, chassis layout, data	2-11
AC-240	Schematic, chassis layout, breakdown, data	2-12

TRAV-LER RADIO & TELEVISION CORP.

6, 7	Schematic, socket	1-1
6, 7 AC & DC Power Packs	Schematic, data	1-1
SG-DX, C	Schematic	1-2
K	Schematic	1-2
Trav-Lette	Schematic	1-2

TYRMAN ELECTRIC CORP.

Tyrman 10	Schematic, Misc.	1-20
Shielded Grid 7	Schematic, Misc.	1-20
Imperial 80	Schematic, Misc.	1-20

UNITED AMERICAN BOSCH CORP.

BAN "B" Power Units	Schematics	1-1
5 AC	Schematic, socket, voltage	1-2
5 AC	Parts values	1-3
16	Schematic, socket, voltage	1-4
20-J, 20-K, 20-L	Schematic, socket, voltage	2-1
20-J, 20-K, 20-L	Chassis, values, data	2-2
27	Schematic, socket, voltage	1-4
28 AC (2 Types)	Schematic, socket, voltage	1-5
28 AC Power Pack	Chassis, parts values	1-6
29 AC	Schematic, voltage	1-5
29 AC, 325 Power Pack	Schematic, chassis, voltage	1-7
31, 32 AC	Schematic, socket, chassis, data	2-3
31, 32 AC	Voltage, parts list	2-4
35	Schematic, socket, voltage	1-4
46	Schematic, socket, voltage	1-4
AC 46, 126, 146, 166, 176	Schematic, socket, voltage, data	1-9
48, 49 AC	Chassis wiring views	1-10
48, 49 AC	Schematic, socket, voltage, data	1-11
54 DC	Chassis wiring views	1-12
54 DC	Schematic, socket, parts list	1-13
56 Battery	Chassis wiring views	1-14
56 Battery	Schematic, socket, voltage	1-15
57, 58	Schematic, socket, voltage, parts list	1-17
58 AC	Schematic, socket, voltage	1-15
66, 76, 76-L	Schematic, socket, voltage	1-15
66 AC, 96, 116, 136 AC	Schematic, socket, parts list	1-16
60, 60-D, 60-E, 61	Voltage, parts list	1-18
62 DC	Schematic, socket	1-19
62 DC	Voltage, parts list	1-20
63 DO	Schematic	1-21
63 DO	Parts list, voltage, data	1-22
73, 74	Schematic, socket, chassis wiring	1-23
73, 74	Schematic, socket, voltage, parts list	1-24
80	Installation notes	2-5
80	Voltage, parts list	2-6
91, 92	Schematic, socket, chassis, data	2-7
91, 92	Schematic, socket, voltage	1-8
96, 156 DC	Installation data	2-8
100 (Advertised 9-20) Auto	Schematic, socket, voltage, assembly wiring	2-9
100 Auto	Schematic, socket, voltage	1-15
107 AC	Adjustment notes, parts list	2-10
108 Police Auto Set	Schematic, assembly wiring	2-11
108 Police Auto Set	Voltage, chassis, socket, data	2-12
205, 206, 5-A, 205-A	Schematic, socket, parts list	2-13
205, 206, 5-A, 205-A	Schematic	2-14
224	Schematic	2-15
226	Adjustments	2-16
812, 813		

UNITED REPRODUCERS CORP.

20 Series	Schematic	1-1
65	Schematic, socket, data	1-2
70 Series (71, 72)	Schematic, socket	1-3

U. S. ELECTRIC CORP.

17	Schematic, socket, data, Misc.	1-21
37	Schematic, socket, data, Misc.	1-21

U. S. RADIO & TELEVISION CORP.		
MODEL		PAGE
7	Schematic, socket	2-1
7	Chassis, alignment data, voltage, data	2-2
7	Service notes, data	2-3
7	Chassis, parts list	2-4
8 Series	Schematic, socket	2-5
8 Series	Chassis layout, voltage, data	2-6
8 Series	Chassis, parts list	2-7
10	Schematic, data	2-8
10	Chassis layout, voltage, data	2-9
10	Chassis view, parts list	2-10
10-C (Chassis 1000-1001)	Schematic, chassis layout, speakers	2-11
10-C (Chassis 1000-1001)	Voltage, speaker notes	2-12
10-C (Chassis 1000-1001)	Chassis view, data	2-13
10-C (Chassis 1000-1001)	Parts list	2-14
20	Schematic, socket	1-1
20	Voltage, servicing notes and data	2-15
20	Alignment data	1-2
26	Schematic, socket, voltage	1-3
26	Chassis wiring	1-4
26-P	Schematic, socket, voltage	1-3
26-P	Parts list, voltage, data	1-4
27 Early	Schematic, socket, voltage	1-5
27 Late	Schematic, socket, voltage	1-5
27-P	Schematic, chassis wiring of motor-board	1-6
28 Early, Below \$373,601	Schematic, socket, voltage	1-7
28 Late, Above \$373,601	Schematic, socket, voltage	1-7
28	Chassis wiring	1-8
29	Schematic, voltage	1-9
30 Auto Set	Schematic, voltage, assembly wiring	2-16
Apex 81	Schematic, socket, voltage	1-10
30-R (Remote Control)	Schematic	1-10
32 Series	Schematic, socket, voltage	1-11
Apex 86	Schematic, socket, voltage	1-12
Apex 87	Schematic, voltage	1-12
41-60, 43-25	Schematic, socket, voltage	1-13
42-60, 44-25	Schematic, socket	1-13
46, 47 Apex, 46-A, 47-A	Schematic, socket, voltage, data	1-14
48, 48-A, 48-W, 48Z	Schematic, socket, voltage	1-15
49	Schematic	1-15
80	Schematic, socket, voltage	1-16
99 Series	Schematic, socket, data	2-17
99 Series	Alignment data, voltage, chassis layout	2-18

VALLEY ELECTRIC CO.		
MB "A" Power Unit	Schematic, Misc.	1-22

VIKING		
See OZARKA, INC.		

GEORGE W. WALKER CO.		
Victorian Standard	Chassis wiring, Misc.	1-23
Victorian Universal	Chassis wiring, Misc.	1-23

WARE MFG. CO.		
T	Schematic	2-1
4-Tube	Schematic	2-1
7-Tube	Schematic	2-1
B-1, B-2 Bantam	Schematic	2-2
SB-45	Schematic	2-3
SBA	Schematic	2-4
S-1	Schematic	2-5
SBF	Schematic	2-5

WELLS-GARDNER & CO.		
C, CG (1st and 2nd Types)	Schematic, socket	1-1
C, CG	Voltage, socket, data	1-2
72	Schematic, socket	1-3
80, 82-A	Schematic, socket, data	1-4
052 Series	Schematic, chassis layout, voltage	2-1

WESTERN ELECTRIC CO.		
D-95508	Schematic	1-1
8-B	Schematic	1-1
8-C	Schematic	1-1
9-A	Schematic	1-2
10-A	Schematic	1-2
17-B	Schematic	1-2
25-B	Schematic	1-3
32-A	Schematic	1-4
41-A	Schematic	1-3
42-A	Schematic	1-4
48-A	Schematic	1-4
45-A	Schematic	1-3
46-A	Schematic	1-4

WESTINGHOUSE ELECTRIC & MFG. CO.		
WR-4	See RCA-Victor 48	
WR-5	See RCA-Victor R-80	
WR-6	See RCA-Victor R-82	
WR-7	See RCA-Victor R-86	
WR-10	See RCA-Victor R-7	
WR-12	See RCA-Victor R-9	
WR-14	See RCA-Victor R-5	
WR-15	See RCA-Victor R-11	

WESTON ELECTRICAL INSTRUMENT CORP.		
Jewell Test Panel	Schematic	1-1
Jewell 133	Schematic	1-2
Jewell 133-A	Schematic	1-2
Jewell 137	Schematic	1-3
Jewell 198, 199 (2nd Type)	Schematic	2-1
Jewell 209	Schematic	2-1
Jewell 214	Schematic	2-2
Jewell 408, 409 (1st Type)	Schematic	1-5
Jewell 408, 409 (2nd Type)	Schematic	1-6
Jewell 444	Schematic	2-3
Weston 526, Type 7	Schematic	1-7
Jewell 533	Schematic	2-4
Jewell 534	Schematic	2-4
Weston 537	Schematic	1-8
Jewell 538	Schematic	2-5
Jewell 540	Schematic	2-6
Weston 547	Schematic	1-10

MODEL		PAGE
Jewell 560	Schematic	2-6
Weston 555	Schematic	1-11
Weston 554	Schematic	1-11
Weston 555	Schematic	1-12
Jewell WD 566	Schematic	1-13
Weston 566	Schematic	1-14
Weston 676	Schematic	2-7

WHOLESALE RADIO SERVICE CO., INC.		
Duo-Symphonic Junior	Schematic, socket, voltage	1-1
1931	Schematic, socket, voltage	1-1
Great Duo-Symphonic	Schematic, socket, voltage, data	1-2
Duo-Symphonic 1930	Schematic, socket, voltage, data	1-2

WILLARD STORAGE BATTERY CO.		
B Unit 3095	Schematic	2-1
AB 3301 G. E. Charger	Schematic	2-2
AB 3301, Westinghouse	Schematic	2-2
B Unit 3310, 4310	Schematic	2-1
B Unit 4095	Schematic	2-1
AB 6301	Schematic	2-2

WORKRITE MFG. CO.		
See U. S. ELECTRIC CORP.		

THE RUDOLPH WURLITZER CO.		
See ALL-AMERICAN MOHAWK CORP.		

ZANEX-GILL CORP.		
Vitaphone 54	Schematic, notes, Misc.	1-24

ZENITH RADIO CORP.		
ZE-3	Schematic	2-1
ZE-4	Schematic	2-1
ZE-5	Schematic	1-4
ZE-6	Schematic	2-1
ZE-9 for Models 11-E, 14-E	Schematic, data	2-2
ZE-10	Schematic	1-5, 1-8
ZE-11	Schematic	1-7
ZE-13	Schematic	1-5, 1-8
11, 12, 14 (1st Type)	Schematic, socket	1-2
12 (2nd Type)	Schematic, socket	1-2
11-E, 14-E	Schematic, socket	1-3
17	Schematic, socket	1-4
27 Super-Zenith	Schematic	1-30
27 Super-Zenith (Series Filament)	Schematic, socket	1-6
31, 32 Battery	Schematic, socket	1-6
ZE-14	Schematic	1-7
33, 34, 35, 35-A, 342, 352, 352-A, 362	Schematic, socket, voltage	1-8
34-P, 342-P	Schematic, socket, voltage	1-7
35-PX, 35-APX, 352-PX, 352-APX	Schematic, socket, voltage	1-9
35-P, 35-AP, 352-P, 352-AP	Schematic, socket, voltage	1-10
37-A	Schematic	1-9
ZE-18	Schematic	1-9
ZE-11 for 35-P, 35-AP, 37-A	Schematic	1-10
ZE-14 for 352-P, 352-AP	Schematic	1-10
39, 39-A, 392, 392-A	Schematic, voltage	1-11
40-A	Schematic, socket	1-11
ZE-12 for 39, 39-A, 40-A	Schematic	1-12
ZE-15 for 392, 392-A	Schematic	1-12
ZE-16 Filter	Schematic	1-12
41, 42	Schematic, socket, voltage	1-13
422	Schematic, socket, voltage	1-13
52, 53	Schematic, socket	1-14
54	Schematic, socket	1-14
52, 53, 54, 55	Voltage data	1-15
ZE-50	Schematic	1-15
60, 61, 62, 64, 67, 602, 613, 622, 642, 672	Schematic, socket, voltage	1-16
ZE-60	Schematic	1-17
ZE-70	Schematic	1-17
71, 72, 73, 77, 712, 722, 732, 777	Schematic, socket, voltage	1-18
70	Tone control installation	1-19
80 Hypermetron	Schematic, socket	1-20
ZE-80	Schematic, parts list	1-21
80 Hypermetron	Parts list	1-22
AH, CH, RH	Schematic, socket, chassis, voltage	1-23
AH, CH, RH	Service data, parts list	1-24
BH (2021)	Schematic, socket, parts list	2-11
LH, MH, WH (2022)	Schematic, socket, data	2-13
I.P.	Schematic, socket, parts list	1-25
6-Tube Zenette, Chassis A, B, C, D (2004)	Schematic, socket, parts list	1-26
5-Tube Zenette, Type 2009-C	Schematic, parts list	1-27
91, 92 (1st Type)	Schematic, socket, data	2-3
91, 92 (2nd Type)	Schematic	2-4
91, 92 (3rd Type)	Schematic	2-5
91, 92	Circuit data	2-6
91, 92	Balancing notes	2-7
91, 92	Chassis view, voltage, parts list	2-8
10, 11, 12, 102, 112, 122	Schematic, voltage, parts list	2-9
10, 11, 12, 102, 112, 122	Balancing notes, SPU notes and Schematic	2-10
Super Zenith, Battery 103 (2017), Serials #450,001-450,450	Schematic	2-14
103 (2017) Above Serial #450,451	Schematic, notes	2-16
103 (2017) Above Serial #451,260	Schematic	2-15
103	Schematic, socket	2-18
103	Chassis view, parts list	2-17
250, 260, 272 (2031)	Chassis layout, voltage	2-19
333, 353-A DC	Schematic, data	2-20
ZE-17	Schematic, socket	1-39
500, 501, 503, 514, 515, 516, 600, 604, 606, 610, 616, 618 (2037)	Schematic	1-39
500, 501, 503, 514, 515, 516, 600, 604, 606, 610, 616, 618 (2037)	Parts list, voltage	2-31
563 DC	Schematic, socket	2-33
	Schematic, socket	1-39

Continuity Testing

condenser is the reverse of that for a perfect inductance. The perfect solid dielectric condenser will indicate an "open" when the continuity tester is applied. The test circuit is shown in figure 2. The heavy dots indicate the terminals upon the condenser and also the terminals upon the test unit. When testing condensers, resistance measurements are not in order. The purpose of the test is to determine whether the condenser is open, perfect, or shorted. Unfortunately it is difficult to arrange a simple test circuit to indicate an "open" because the indication for a good condenser is very similar to that for an open circuit in the condenser. The difference between the two is that a perfect condenser will cause a momentary deflection upon the test meter. The meter pointer "kicks" upward to indicate the flow of the charging current. However such an indication cannot be obtained when very small values of capacity are being tested, unless a high voltage and a high ohms-per-volt meter are used.

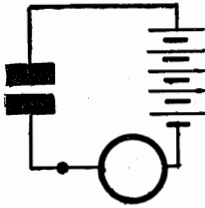

Fig. 2

An indication of some value between zero and maximum is a sign of a leak, that is a steady indication. A steady indication equal to the voltage rating of the battery is a sign of a short circuit in the condenser. During such tests the operator must be certain that the condenser under test is mounted upon an insulated surface and that his hands are not in contact with the uninsulated portions of the test prods. Physical contact with the test prods during the process of the test is apt to cause a misleading indication of leakage upon the voltmeter.

The test as stated is applicable only to solid dielectric condensers. The "dry" and "wet" types of electrolytic condensers must be tested in different fashion. These condensers should be tested for leakage by applying a D.C. potential equal to the rating of the condenser, approximately 350 volts. The polarity of the condenser must be observed. A milliammeter is connected into the test circuit. The correct value of leakage current for the "wet" type of electrolytic condenser is a maximum of about .5 milliamperes per microfarad, and for the "dry" type of electrolytic condenser a maximum of about .1 to .25 milliamperes per microfarad.

When checking condensers located in receivers be certain that no shunt D.C. path is present across the condensers. Thus it is impossible to check the continuity of tuning condensers in a conventional tuned radio frequency stage without disconnecting the tuned circuit. The same is true when checking the continuity of a fixed condenser connected across an audio frequency transformer. The condenser must be disconnected from the transformer. Opening one lead is sufficient.

RESISTANCES.

Continuity testing of resistances is usually in the form of a resistance test. In view of the fact that the function of the resistance in most cases is to produce a voltage drop, it is equally important to determine the ohmic value as well as the state of continuity. The method of applying the continuity tester-ohmmeter is as shown in figure 1 and repetition of the schematic is unnecessary. A resistance which is intact will show a steady deflection. One that is open will show no deflection. If the rated resistance is known, the observed ohmic value can be compared with the rated value to determine the suitability of the resistor.

In connection with resistance tests or continuity tests upon resistances it is necessary to make mention that the current flow through many resistances is limited to a small value. Thus by employing a test circuit which does not require more than 1 milliamperes current flow of maximum indication, one is reasonably certain of causing no damage to the resistor during the test.

In the event that the meter deflection is not steady when the test is made it might be well to investigate all connections in the circuit in order to determine if the unsteady deflection is due to a defect in the resistor. Resistances which are productive of unsteady deflections during a test will be found to be productive of noise when placed into a receiver, eliminator or amplifier.

CONTINUITY TESTING IN A FINISHED RECEIVER.

Perhaps we appear as placing too much stress upon continuity testing and upon circuit structure. We feel that what will follow will offer conclusive proof of the fact that a great deal of time may be saved by correct application of a continuity test and that it is absolutely necessary that the operator be familiar with the circuit under observation.

Basically the modern radio receiver is like its brethren of years gone by, but so many pet ideas are added that the actual testing of the circuit is somewhat more complicated than in the simple days of the past. Of course we still encounter radio receivers of simple yet effective design, in which case the conventional continuity test based upon the most elementary receiver is still applicable. Perhaps it might be well to consider receivers of different types. In view of the fact that voltage tests and the set analyzer have not as yet been discussed there shall be no reference to symptoms or to open circuits as indicated by a voltmeter or current meter test. The reader may if he so wishes imagine each of the circuits mentioned as being open at one point.

Let us start with a simple circuit. Figure 3 is the schematic of the Earl 21-22 receiver. An examination of the circuit shows that the ground is common to all grid circuits and to the B-circuit. Under the circumstances the ground contact can be used as the common point for most tests.

Suppose that we select the ground as the common terminal for the continuity tester and check the respective circuits. We shall call the ground terminal number 1. Other points will bear higher numerical designations. It is understood that the tubes are not in their respective sockets, for the want of more accurate data we will assume that the D.C. resistance of the respective radio frequency transformer secondary windings is 4 ohms each; of the first stage audio frequency transformer secondary, 4000 ohms, the primary, 1000 ohms, the primary of the second stage audio transformer, 1600 ohms and the complete secondary is 10,000 ohms, 5000 ohms each side of the center tap. The two filter chokes in the power pack are assumed to have a resistance of 300 ohms each. Let us proceed.

From ground (1) to the L.A. binding post (2) would show continuity through the aerial coupling coil. Between L.A.(2) and the grid(3) of the first RF tube with the volume control set at minimum should show continuity of low resistance through the variometer. If this variometer is open the continuity would be high because of the presence of the 25000 ohm potentiometer. To

Continuity Testing

test. Undoubtedly a number presented themselves to the reader as we progressed through the continuity test of this receiver.

What has been said in these pages is not intended as a definite statement that all forms of test other than continuity should be discarded. The conventional voltage test provides the information necessary for the selection of the circuits to which will be applied whatever form of continuity test is being used by the operator. The continuity test should show whether or not the set can be repaired in the home.

Suppose we refer once more to figure 4. The conventional voltage test indicates that there is no plate voltage being applied to the radio frequency, detector and first audio frequency plate. The plate voltage applied to the output tube appears normal. The probable cause according to the diagram is in the voltage divider, or for that matter such would be the conclusion based upon a knowledge of eliminator systems. Unless a continuity test is made, it is impossible to definitely state whether or not all of the resistances must be replaced or if the connection between the filter choke and the high end of the divider is open or if the 4700 ohm resistance is open. A few minutes spent in a test between (1) and (17) would show if the 15000 ohm unit was intact, and another test between (17) and (20) would show if the 25000 ohm unit was intact. The last named test can also be made by checking between (1) and (18), (20) or (21). Radio frequency socket (19) could be used providing that the volume control unit was adjusted to minimum resistance or maximum signal.

Assuming that the fault is an open between the radio frequency plate voltage tap and the output end of the filter, a temporary repair is possible if the resistance is of the open wire type. If not, the man can call the following day with another replacement unit and make the change right in the home, thus obviating the necessity of carting the chassis, perhaps making entries in a receiving department and other such details.

Reference to the discussion about circuit continuity, with particular attention to the presence of the bleeder unit will show the difference involved during the continuity testing of such circuits. We suggest that the reader consult the section devoted to set analyzer application. The method of determining the presence of such bleeder units is discussed in detail.

Proceeding into the plate circuit, we can check the total resistance of the voltage divider by contacting between (1) and (16), the center tap upon the speaker plug winding or the center tap upon the output transformer. A simpler method is to check between (1) and (17), the plate of the detector tube. The total resistance should be the sum of the associated part of the divider and the first audio transformer primary. A short circuit in the detector plate bypass condenser would cause zero reading. A short in the voltage divider bypass condenser would cause a reading equal to the resistance of the audio transformer primary.

A test between (1) and (18), (19) and (20) would indicate the continuity in the respective plate circuits. The resistance would be that of the divider sections present in the circuit. The test between (1) and (21) would indicate the continuity in the first audio frequency stage. Since all of these tube plates are tied to a common feeder an open in all the plate circuits would indicate an open in the feeder cable. An open in but one plate circuit would immediately localize the trouble to that particular stage. A short circuit in all the R.F. circuits would immediately localize the trouble to a short associated with the radio frequency part of the system, the bypass condenser or the voltage divider resistance. The audio amplifier plate circuit would show the resistance represented by the transformer primary. A short circuit in the audio frequency plate and an indication of low resistance between (1) and the respective radio frequency plates would immediately localize the trouble to a short in the first stage audio frequency plate circuit.

The reason for the aforementioned is that while the first audio frequency tube may be directly shorted to ground, the plates of the radio frequency amplifiers are still isolated from ground by the resultant resistance of the first stage audio frequency transformer in shunt with the associated portion of the voltage divider.

A test between (1) and (22) and between (1) and (23) will show the condition of the respective halves of the output transformer winding or choke and the divider section. If the voltage divider bypass condenser is shorted, the test between (1) and (22) will indicate the presence of the resistance represented by one half of the output unit winding. The same applies to the test between (1) and (23).

The first (input) filter condenser can be checked by a test between (1) and (24) the filament of the rectifier tube. The correct value of resistance in this circuit should total the complete divider plus the sum of the two filter chokes. A check between the filament of the rectifier and the center tap connection to the output unit (16) should show the resistance of the chokes. If the second filter condenser is shorted and a check is made between (1) and (24), the amount of resistance indicated will be that of the first filter choke. If the output filter condenser is shorted and the test is made between the two points last named, the value of resistance indicated will be the sum of the two chokes. The resistance of the divider does not influence the reading.

No doubt the reader has observed that a large number of tests can be made without removing the chassis from the cabinet. The proper contact with the respective socket terminals can be made by means of plugs or the conventional test prongs. We did not include every possible

Point-to-Point Testing

Tolerance limits pertaining to the resistance of r-f and i-f windings are much closer. In a-f winding, a tolerance of from 5 to 10 percent will be experienced in practice. The exact limits used by the different radio receiver manufacturers are unknown, but this does not complicate matters for the simple reason that the organization which employs a close limit, will use resistors which very closely approximate the rated value.

Voltage Co-efficient in Resistors.

Another item which must be recognized in connection with the measurement of resistors in receivers and amplifiers is the voltage co-efficient of carbon resistors. We specify the type of unit, because the same condition does not as a rule apply to wire wound and metallic coated units.

Carbon resistors should be checked at the voltages employed by the resistor manufacturer. The reason for this is that the nature of the resistor is such that its resistance (d-c) will vary according to the test voltage applied because of the current flow through the unit. This item is not the temperature co-efficient of resistance. Checking at some voltage other than that employed by the resistor manufacturer will result in the determination of some value other than the true rating when the correct voltage is applied.

However, since the correct values of voltage are not known, it is best to employ the lowest possible test voltage required to show a normal indication upon the resistance measuring device. This problem of voltage co-efficient is not native to resistance measurement method of analysis only, but is to be found when resistance is measured subsequent to a voltage test. Perhaps some time in the future, certain standards will be evolved to designate the exact test voltage to be applied to carbon resistors of various values.

By employing the lowest possible test voltage, we at least safeguard the unit against damage by overload. An approximation of the correct voltage (test) can be had by noting the position of the unit in the circuit and the voltage drop across the unit. Thus high resistors used in the plate circuits of audio frequency and detector tubes are subjected to voltages ranging from about 90 to perhaps 150 volts. Low range units used in bias circuits, varying from 10,000 to about 50,000 ohms are usually subjected to voltages ranging from 10 to perhaps 30 volts. Fortunately, the presence of a defective resistor can be detected when a low voltage is applied, despite the fact that the correct test voltage for a resistor of the type and value being checked may be much higher. In this respect, you as the operator must apply your knowledge and make your own interpretations.

Electrolytic Condensers In The Circuit.

Point To Point Resistance Data

The application of the point-to-point data is a matter entirely within your own hands. It has been prepared along the lines which will enable a routine test upon the receiver by working through the tube sockets, thus obviating the necessity for the removal of the chassis, until the defect has been located. The condenser test is in the majority of instances likewise applicable through the sockets.

Tolerance Limits.

One of the precautions which must be exercised in connection with resistance measurement and this applies to the point-to-point test or to the resistance test subsequent to the voltage test is to allow sufficient tolerance.

While it is true that the values shown in circuits are exact and definite, the actual units employed in the receiver do not have the exact values marked upon the diagrams. By this we mean that a certain amount of tolerance is employed in the manufacture of the resistor and this must be recognized during the test. The tolerance limits are in a way determined by the function of the resistor and its location in the circuit. Units used in circuits which do not carry direct current have tolerance values between 10 and 15 percent. Units which carry direct current have tolerance limits which range from about 3 to 10 percent. The lower limit is to be found in filament circuit and in voltage divider resistors. An optimum range of tolerance limits for units which carry current, exclusive of the filament system is from 5 to 10 percent plus or minus.

These tolerance limits are not present in resistance measurement methods of servicing only, but are also present in voltage testing, since the variation in resistance will cause a variation in the voltage. Furthermore, the final test during voltage measurement, is the resistance test, so that the same condition applies to that test.

Point-to-Point Testing

The presence of an electrolytic condenser across a resistor will influence the resistance between two prescribed points and at the same time influences the voltage which may be applied across those two points. The variation in resistance is due to two conditions. One of these is related to the polarization of the electrolytic condenser. This type of condenser possesses one value of resistance, fairly high when the test is made with the correct polarity and a low value of resistance when checked with incorrect polarity of the testing voltage.

Therefore, it is necessary when checking resistors which may have connected across them some value of capacity, which may or may not be of the electrolytic type, to measure the resistance with the polarity of the testing voltage in both directions. This precaution is unnecessary, if the polarity of the testing voltage is maintained in conformity with the polarity of the circuit being checked. In some cases this is impossible, but it is possible in the majority of instances.

An example of the foregoing is the following. When testing grid bias resistors, the cathode or the filament centre tap are positive with respect to the chassis. The polarity of electrolytic condensers is taken into consideration when they are connected into the circuit. By arranging that the polarity of the resistance measuring system conform with the polarity of the resistor circuit when in operation, the correct polarity with respect to the electrolytic condenser is assured. In the event that the condenser connected across that resistor is not of the electrolytic type, all well and good, but if it is, correct testing circuit is applied.

A similar requirement of polarity is required when checking the resistance of units related to the rectifier filament. This terminal is positive with respect to the balance of the circuit when in operation and when making resistance tests from the rectifier filament to some other point, the polarity of the tester prod connected to the rectifier filament must be positive.

The second factor associated with electrolytic condensers is that of voltage. The usual circuit arrangement of the resistor being tested and its associated condenser is such that the voltage applied across the resistor is also applied across the condenser, since these two units are connected in parallel. Accordingly, the test voltage applied to the resistor for measurement of its ohmic value cannot exceed the operating voltage rating of the condenser. If it does, damage is the consequence.

Fortunately, low voltage electrolytic condensers are used in shunt with low values of resistance, as for example pentode bias units. Consequently, the test voltage required to check resistors of values ranging from 100 to perhaps 1000 ohms, will be sufficiently low so as not to damage the condenser or cause excessive leakage.

Electrolytic type bypass condensers in other circuits are usually within the 200 to 250 volt range, so that normal application of the tester is possible. As far as filter condensers of the electrolytic variety are concerned, the voltage rating is about twice as great as the usual testing voltage applied to the voltage divider circuits.

A third item related to electrolytic condensers and also associated with the measurement of resistance is the normal resistance of the condenser. As is well known, the insulation resistance of an electrolytic condenser is not as great as that of a solid dielectric unit. As a matter of fact, it is only a small fraction of the d-c resistance of a paper dielectric or mica dielectric unit. Accordingly, it will have some effect upon the resistance between any two prescribed points. Just what this resistance will be is not always known, but it is determined by the condition of the condenser and by the testing voltage.

If a receiver or amplifier has been inoperative for a long period of time, the ohmic value of a resistor shunted by an electrolytic condenser cannot be determined unless the condenser is disconnected. The reason for this is that the insulation resistance of an electrolytic condenser which has been inoperative for a long period of time is very low, in fact so low as to greatly influence the resistance across its terminals.

As far as perfect electrolytic condensers are concerned, the fact that leakage current flows through the condenser and that its insulation resistance is much lower than that of the solid dielectric unit must be taken into consideration. The electrolytic condenser connected across a resistor being checked is the equivalent of a shunt resistor of a certain value, determined by the leakage current through the condenser at the testing voltage.

If the voltage rating of the electrolytic condenser is high and the testing voltage applied across the circuit is low, the shunting effect of the condenser will be negligible, particularly if the ohmic value of the resistor being checked is low. It may be necessary to first determine if an electrolytic condenser is present in the circuit by comparing the readings obtained with the polarity of the test circuit, first in one manner and then reversed and then to disconnect the electrolytic unit. By maintaining the testing voltage at the lowest possible value, the effect of the shunt electrolytic condenser is minimized. Experience shows that the most frequent occasion for disconnecting the electrolytic condenser occurs when checking voltage divider circuits.

Fractional microfarad bypass condensers have low leakage. The normal rating of electrolytic condenser is somewhere around .1 to .25 milliamperes per microfarad. For a .25 microfarad unit, the

Point-to-Point Testing

Point To Point Resistance Data

leakage current at say 200 volts d-c after a normal period of application would be about .00061 ampere. This means a value of resistance sufficiently high to have very little effect upon whatever units are being bypassed by the condenser.

Because of the nature of the electrolytic condenser, the resistance test voltage applied across a resistor shunted by an electrolytic condenser should be kept across the contact for a short period of time, say at least a minute for fractional microfarad units, unless the measured value of resistance indicates a normal state. In every case, the shunt effect of the condenser will lower the resistance between the test points.

In the case of filter circuits, it may be necessary to keep the resistor test prods connected across the circuit for about 5 minutes, unless the measured value immediately after application shows a normal state. In work of this type, a great deal depends upon the operator.

Once more we wish to mention that the facts named, are not native to resistance measurement methods of service analysis, but will be experienced if the resistance test is made subsequent to the voltage test. If you are in the habit of removing the chassis before making the tests, which is not necessary with point-to-point method of operation, you may find it advantageous to disconnect the filter condensers, if they are of the electrolytic type.

Solid and Air Dielectric Condenser Tests.

Solid and air dielectric condensers, unless shorted, have no effect upon shunt resistors, and there is no need for polarity specification. However in certain instances, as for example across bias units and across the voltage divider it is best to always connect the ohmmeter as stated in connection with electrolytic condensers. In this manner, you are certain of having the correct polarity in the event that the condenser in the circuit is of the electrolytic variety.

Open Condensers.

One of the greatest service problems encountered today is the intermittent and permanently open condenser. It is true that condensers become shorted, but when shorted, will indicate that effect by short circuiting the associated resistors, hence will be detected when the resistance test is made.

It has been customary in the past to check for open condensers by connecting a perfect condenser across the terminals of the suspected condenser and noting the effects. However, this requires that the receive be in operation and there is possibility of electrical shocks to the operator and maybe short circuiting of circuits by accidental contacts. Another method is to disconnect the suspect condenser and check it for capacity; the design of the capacity measuring unit being such as to indicate the open.

Point to point resistance data contained in this manual appears in two forms. Where the information was compiled by the writer it appears as a coded tabulation. Where the information was compiled by the receiver manufacturer, it appears as a tabulation of normal order and is referred to as "Resistance Data" in the corner card. The same designation is applied to the writer's tabulation. The resistance test can be applied in any one of a number of ways. It is equally effective with the chassis removed or by operating via the tube sockets with the tubes removed.

The conditions under which these tests are made are as follows.

1. The tubes are tested separately.
2. The line voltage or battery voltage are determined independently of the receiver.
3. In a-c receivers, the a-c voltage applied to the receiver anodes is measured with an a-c meter without the rectifier or the other tubes in their sockets.
4. In a-c receivers the filament voltage is measured.

Additional conditions are named upon the pages giving the resistance details for the various receivers. The following abbreviations are used and the method of application will be described later.

TUBES

RF - rf	Radio Frequency
AF - af	Audio Frequency
IF - if	Intermediate Frequency
Det	Detector
Osc	Oscillator
Rect	Rectifier
AVC	Automatic Volume Control
AVCX	Combination automatic volume control and detector

TUBE ELEMENTS

Cg	Control grid
K	Cathode
F	Filament
H	Heater
Sg	Screen grid
Sup	Suppressor grid
P	Plate

Point-to-Point Testing

CONDENSERS

- BC Bypass condenser
- FC Filter condenser
- CC Coupling condenser
- BLG Blocking condenser

MISCELLANEOUS

- Tr Transformer
- Cplg Coupling
- wdg Winding
- Y Chassis
- chk Choke
- mfd. Microfarad
- mmfd. Micromicrofarad

The data pages are arranged to show the test made between the chassis and the various tube elements or circuits listed in the first column. These points are reached through the tube sockets working from the top of the chassis, or from the lead sockets assuming that a plug-cable method contacting the tube circuit is used.

The second column gives the correct value of resistance to be found in the circuit. These figures are the rated values and the tolerance limits must be applied. If the units used in the circuit are exactly as rated, the resistance to be expected is the quoted value. Of course electrolytic condensers must also be recognized.

The third column states probable reason for incorrect resistance between the points named, assuming that the tolerance limits have been applied. No special mention of open resistors is made unless they are in parallel circuits, on the assumption that if the resistance test indicates an open, the subsequent operation will be to locate the open resistor.

The tests have been arranged in such fashion as to enable isolation of the various units employed in the receiver, thereby enabling immediate localization of the defect in the event of a short circuit or an open circuit indication.

The third column states the probable fault and its location. An example is the following.

RF Plate	Correct	Incorrect
	13,026 ohms	BC- rf P wdg- Y (1 mfd.)
		BC- 2 D AF Tr- 2 D K
RF Plate to '47 Screen	26 ohms	FC- 2 RF P wdg-Y (8 mfd)

Between the r-f tube plate and chassis, the resistance to be expected according to the units used in the circuit is 13,026 ohms, providing that everything is correct. Because of the nature of the circuit, that is, current flow through the system, the tolerance limit is quite low, between 5 and 10 percent. Supposing that it shows a marked difference, which means that the "incorrect" column would be referred to.

The first possible reason for the defect is the "bypass condenser connected between the rf plate winding and the chassis. It is a 1. mfd unit". The abbreviations used are not difficult to comprehend, since they are definitely associated with the names of the units.

The second possible reason for the defect is the "bypass condenser connected between the 2nd Detector tube audio frequency transformer and the 2nd detector cathode"

The third possible reason for the defect is the "filter condenser connected between the 2nd radio frequency tube plate winding and the chassis, an 8 mfd. condenser".

Because of common circuit connections, the defect will not always be a part of the tube circuit immediately contacted. However, the defect in the circuit may be located in an associate tube.

The subsequent tabulation affords a means of isolating the radio frequency transformer primary winding, which is connected to the plate of the radio frequency tube. Naturally a defect in a resistance (r-f winding) of 26 ohms will have very little effect upon a total circuit resistance of 13,026 ohms, so that it is necessary to isolate the plate winding in order to check its resistance. This is done as stated.

Another example of the application of the abbreviations is as follows:

2 Detector Control Grid	50 ohms	TC- 2 D Cg-Y
-------------------------	---------	--------------

This means that the correct resistance between the 2nd detector control grid and the chassis should be 50 ohms. If a defect is indicated, check the "tuning condenser connected between the 2nd detector control grid and the chassis"

All of the items listed under the incorrect heading are those which will influence the resistance between points. As far as open condensers are concerned, the condenser test must be applied. With respect to neutralization, incorrect alignment, etc., the routine operations are required.

MODEL Falck 77-88-89

ADVANCE ELECTRIC CO

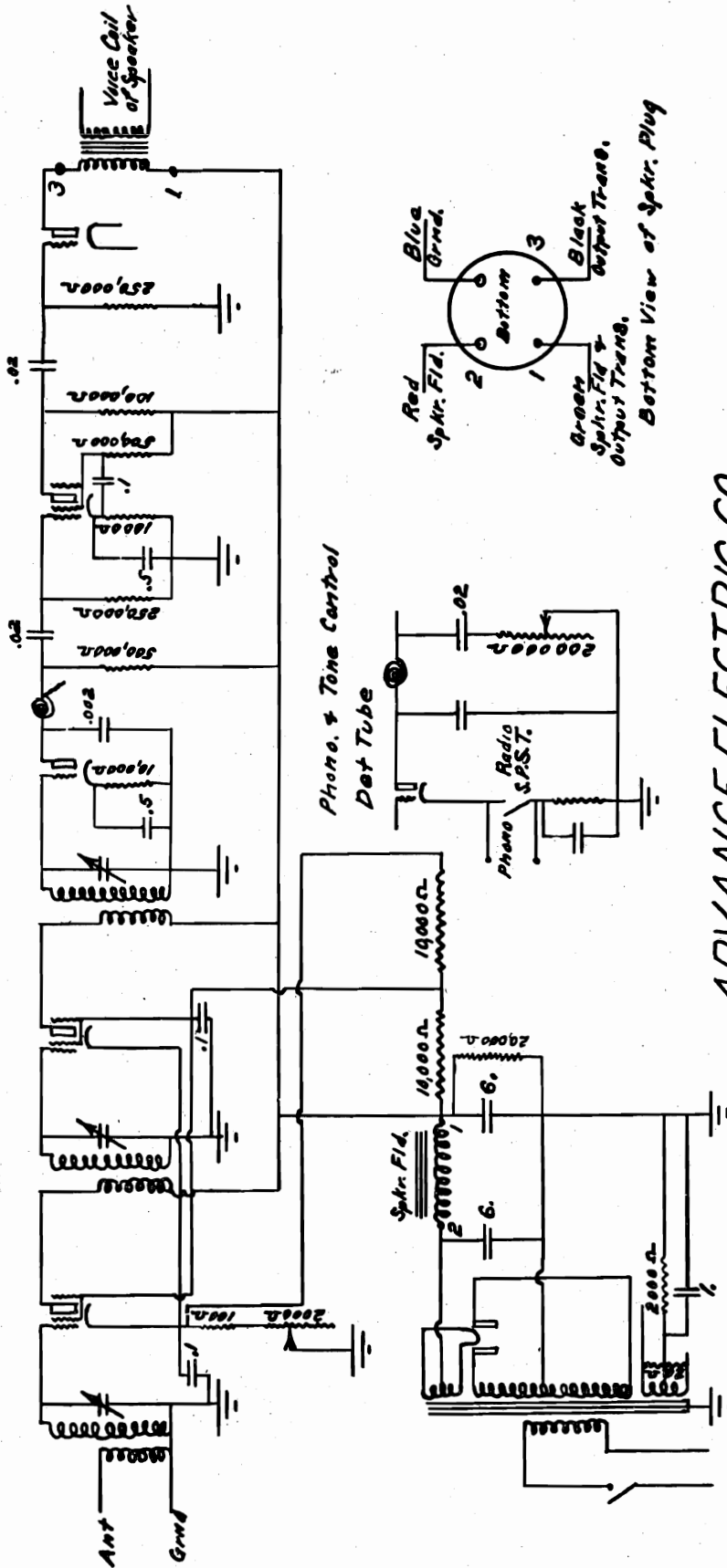

ADVANCE ELECTRIC CO.
 FALCK MODELS 77-88-89
 Oct., 29, 1930 Drawn by E.O. Woodward

ALLIED RADIO CORP.

MODEL KNIGHT SG-8
Bottom View

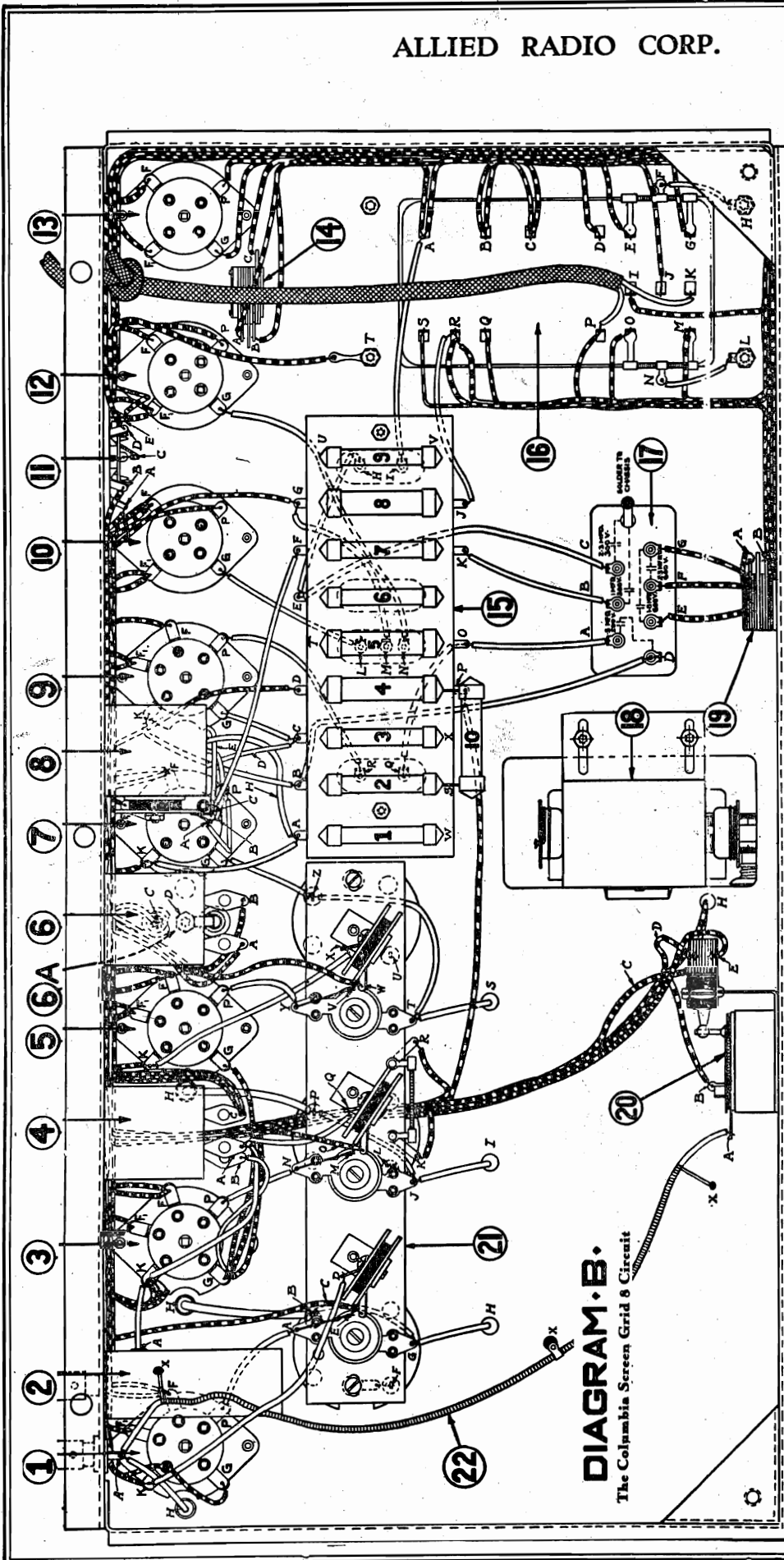

KNIGHT MODEL SG-8 BOTTOM VIEW

DIAGRAM B.

The Columbia Screen Grid 8 Circuit

Readings, Plug In Socket Of Set

Tube No. In Order (1)	Type Of Tube (2)	Position of Tube 1st, R.F. Det., Etc. (3)	Tube Out		A Volts (5)		B Volts (7)		C Volts (Control Grid) (8)		Tube In Tester		Plate M.A. Grid Test (11)	Plate Change M.A. (12)	Screen Grid Volts (13)
			A Volts (4)	B Volts (6)	A Volts (6)	B Volts (7)	C Volts (8)	Cathode-Heater Volts (9)	Normal Plate M.A. (10)						
1	224	1st R.F.	2.45	180	2.4	174	1.5	1.5	4.5	6.7	2.2	80	2.2	80	
2	224	2nd R.F.	2.45	180	2.4	174	1.5	1.5	4.5	6.7	2.2	80	2.2	80	
3	224	3rd R.F.	2.45	180	2.4	174	1.5	1.5	4.5	6.7	2.2	80	2.2	80	
4	227	Det.	2.45	106	2.4	106	3.	3.	3.2	3.8	3.	22	3.	22	
5	227	1st A.F.	2.45	162	2.4	68	3.	3.	3.2	3.8	3.	22	3.	22	
6	245	2nd A.F.	2.35	230	2.2	212	3.8	3.8	20	23	3.	22	3.	22	
7	245	2nd A.F.	2.35	230	2.2	212	3.8	3.8	19	22	3.	22	3.	22	

Line Voltage 115. Set on Low (1) Volt Tap. Volume Control Position Maximum.

MODEL KNIGHT 118
AVC Super 1930

ALLIED RADIO CORP.

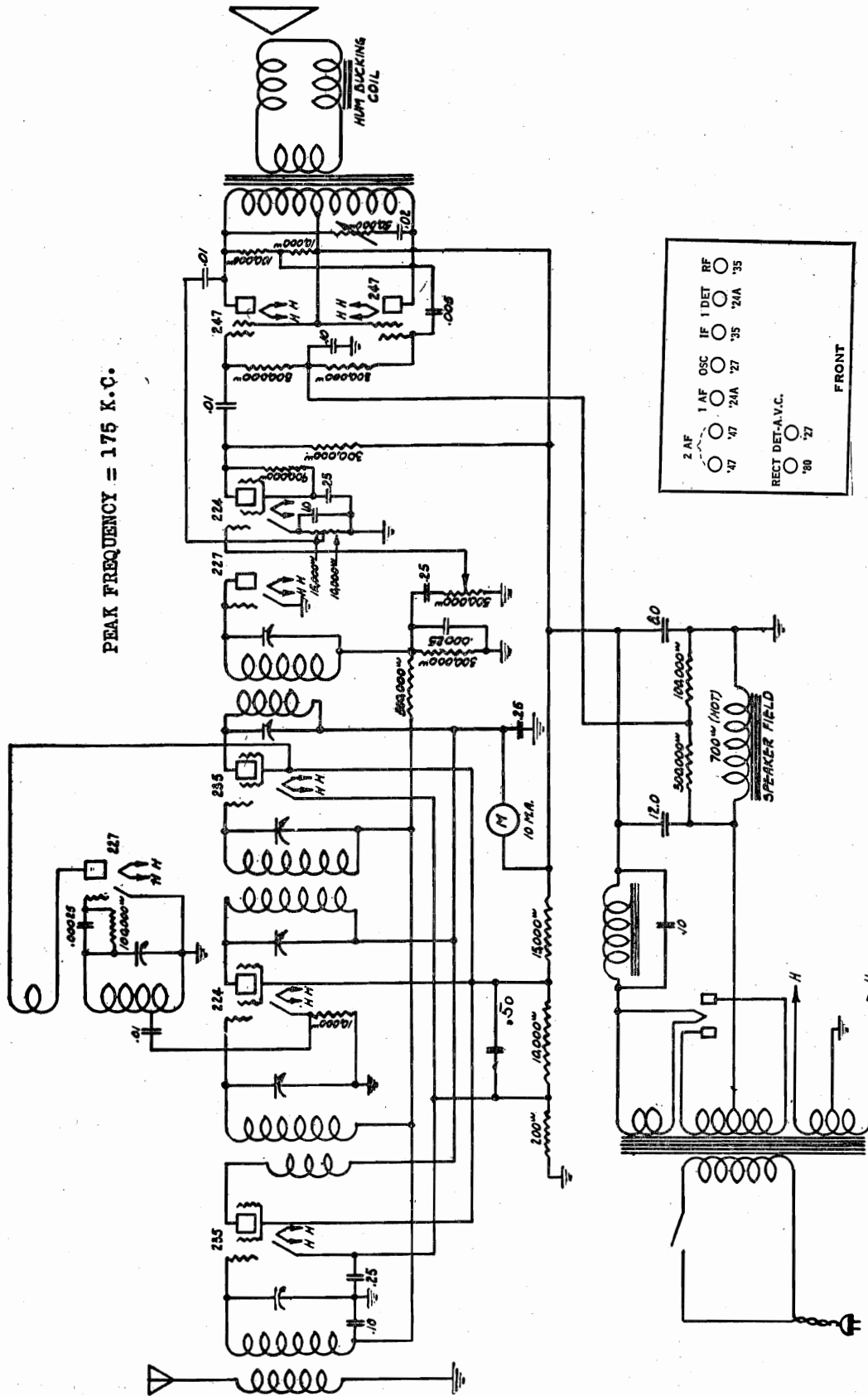

ELECTRO DYNAMIC SPEAKER:
The electro dynamic speaker field winding, which is 700 ohms, is utilized as an additional choke in the filter circuit. The correct bias for the two 247 output tubes is obtained from the voltage drop across the speaker field shunt resistors.

ALLIED RADIO CORP.

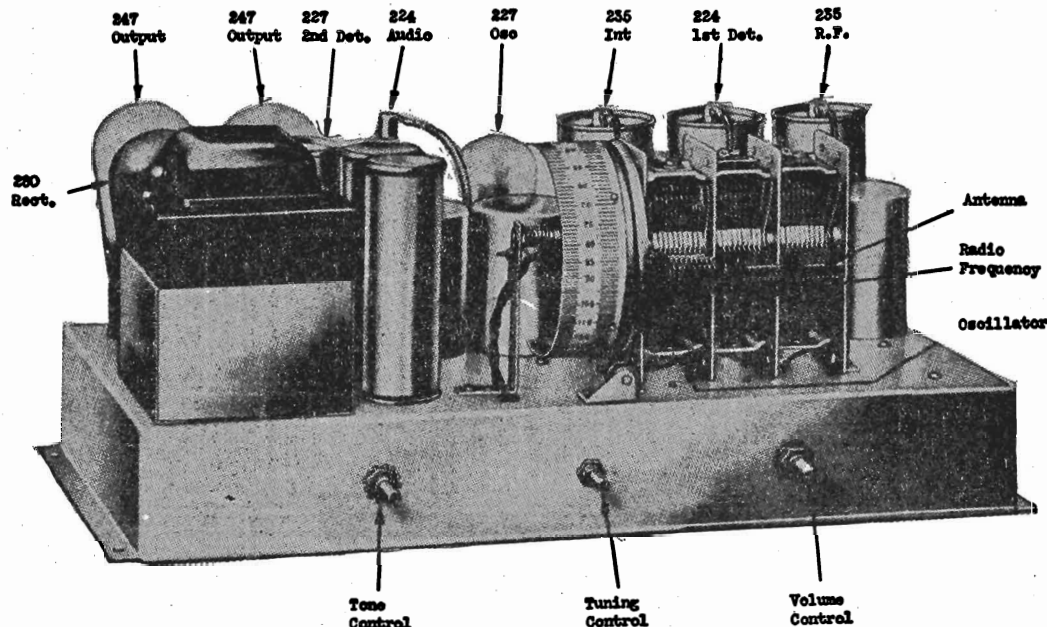
MODEL KNIGHT 118
Service Notes**ALIGNMENT OF RECEIVER:**

Because of the construction and thorough impregnation of the intermediate coils, the intermediate stages should rarely need retracking. Only when an intermediate coil has become defective due to an open or burned out winding, should it be necessary to readjust the intermediate trimmers. Should this occur, it is necessary that an oscillator be used and the intermediate trimmers be adjusted at 175 kilocycles. To align the intermediate stages, connect the high side of the oscillator output to the grid circuit of the first detector, which is done by disconnecting the grid cap of the 224 first detector and connecting the high side of the test oscillator to the control grid of this tube. The ground side of the test oscillator should be connected to the ground post on the chassis. Set the oscillator at 175 kilocycles and adjust the output of the oscillator so that a convenient reading is obtained on the output meter. Be sure that the output from the oscillator is not so large that it will overload the second detector. If during the alignment the meter goes off scale, reduce the output of the test oscillator or adjust the receiver volume control.

The trimmers of the intermediate coils are accessible through the small holes in the bottom of the chassis. There are two trimmers to each intermediate coil. Align the grid trimmer of the first intermediate coil. After a maximum reading is obtained by adjusting the grid trimmer on the first intermediate, adjust the primary for maximum reading and then recheck the grid side to make certain the alignment of the secondary has not been changed by the adjustment of the primary. The same procedure is followed in aligning the second intermediate coils. After both intermediate coils are properly aligned the adjustment of the intermediate stage is complete and they should not be further disturbed.

Replace the grid cap on the first detector and connect the oscillator output leads to the antenna and ground posts of the receiver and set the oscillator at 1435 kilocycles. Then tune the receiver to 1435 kilocycles on the dial. It is important that the receiver be tuned to this point. If the receiver is out of the cabinet it will be necessary to use some temporary indicator so that the position 1435 kilocycles on the dial may be accurately located. (This indicator should be set so that when the variable condensers are at the maximum capacity stop the indicator points to the last line on the dial at the low frequency end.) Then track the variable condensers by adjusting the trimmer condensers in the following order: Oscillator, antenna and radio frequency - (reading from the front of the receiver toward the back, the variable condenser sections are: Oscillator, antenna and radio frequency). After the variable condensers have been properly tracked at 1435 kilocycles, adjust the oscillator to 1295 kilocycles. Tune the receiver to this frequency. Check alignment of the condensers at this point by bending the end plate of the rotors in and out, noting the change in reading on the output meter. If when the plates are bent in the reading is increased, it is an indication that that particular section requires more capacity and the end plate should be permanently bent in at this point; or, if when the end plate is bent away the reading is increased, the end plate should be bent away permanently, as it is an indication that that particular section requires less capacity at that particular point. The variable condensers should be checked in this manner at 1895, 880, 650 and 550 kilocycles. These points have been chosen so as to take advantage of the slots in the end plates of the variable condensers. This procedure of bending plates should rarely be necessary on the oscillator section, as the plates of the oscillator section are especially designed to properly track over the broadcast spectrum, providing the antenna and radio frequency stages are correctly aligned.

Tube Voltages

Type of tube	Position of Tube	Filament Volts	B Volts	C Volts	Normal Plate M.A.	Screen Volts
227	Oscillator	2.4	62.5		4.75	
235	Radio Frequency	2.4	240	2.15	2.75	27
224	1st Detector	2.4	230	4.35	.5	65
235	Intermediate	2.4	237	2.15	2.75	72
227	2nd Detector	2.4				
247	Pentode	2.4	220	8.**	32.5	250
247	Pentode	2.4	220	8.**	32.5	250
230	Rectifier	4.9			47.5 ea.plate	
224	1st Audio	2.4	100	2.1*	.5	35*

115 V. line Volume Control Full On

**To read the 247 bias, read between 247 grid and ground.

*These readings are only comparative and are not true voltages applied. The volt meter, when the readings are taken at these points, is in series with a very high resistance.

ALLIED RADIO CORP.

MODEL KNIGHT 7 Tube Superhet '32

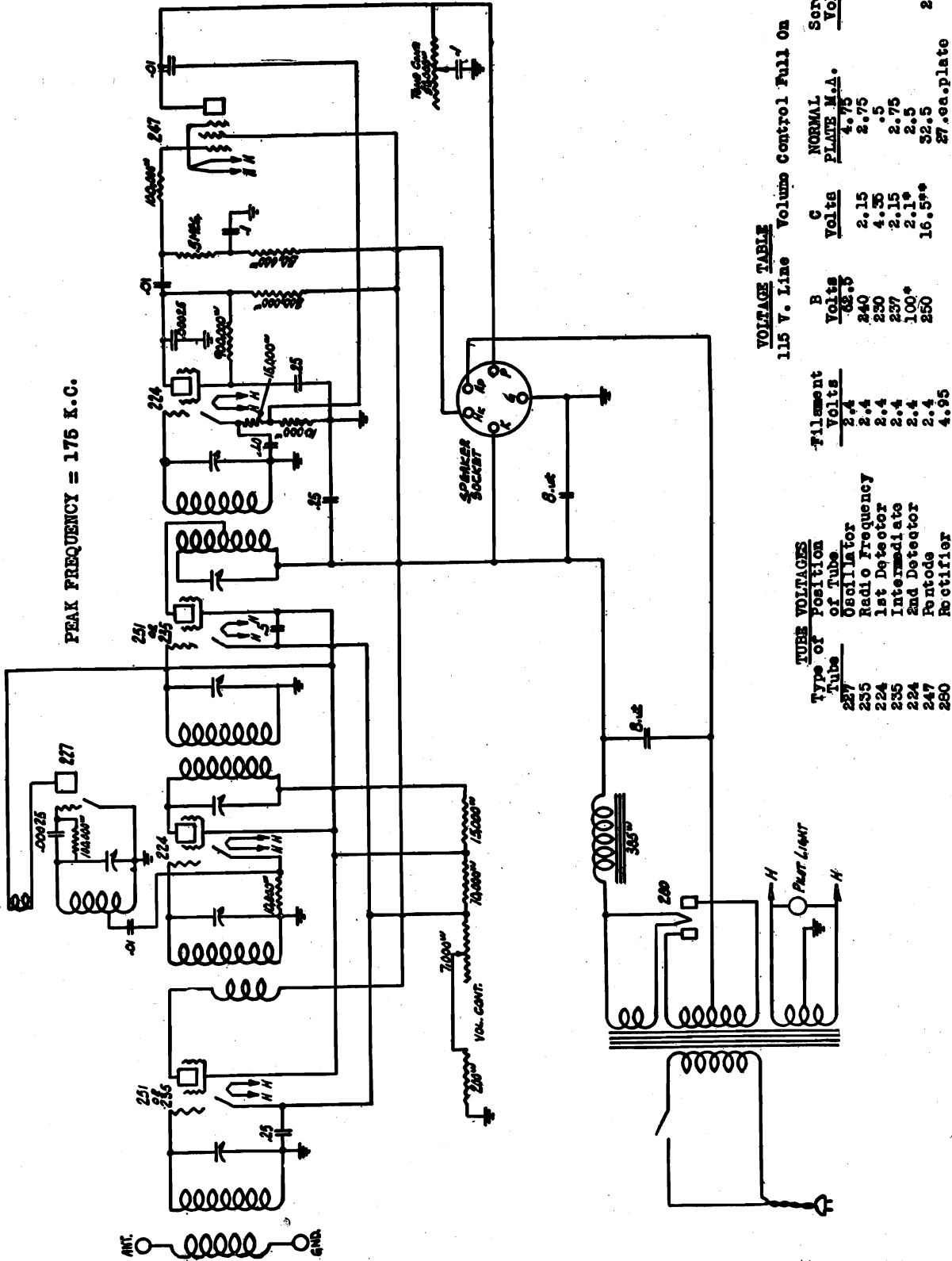

VOLTAGE TABLE
115 V. Line Volume Control Full On

TUBE VOLTAGES	Tube	Position of Tube	Filament Volts	B Volts	C Volts	NORMAL PLATE M.A.	Screen Volts
	227	Oscillator	2.4	240	2.15	4.75	27
	235	Radio Frequency	2.4	230	4.35	2.75	65
	224	1st Detector	2.4	237	2.15	2.75	72
	224	Intermediate	2.4	100*	2.1*	2.5	35*
	224	2nd Detector	2.4	250	16.5**	32.5	250
	250	Rectifier	2.4	250	27 ea. plate		

*These readings are only comparative and are not true voltages applied. The volt meter, when the readings are taken at these points, is in series with a very high resistance.
** To read the 247 bias, read between H.K. speaker socket and ground.

KNIGHT 7 TUBE SUPERHETERODYNE
1932 MODEL

**MODEL Knight 7 Tube
Superhet '32
Service Notes**

ALLIED RADIO CORP.

KNIGHT 7 TUBE SUPERHETERODYNE 1932 MODEL

INTERMEDIATE TRANSFORMERS:

The intermediate transformers are of the band pass type and of exceptionally high uniform gain. They are tuned to 175 kilocycles. The intermediate frequency trimmers are mounted on an isolantite base, preventing the transformer from becoming detuned due to the trimmer condensers absorbing moisture or warping. For this reason it should rarely, if ever, be necessary to re-track the intermediate frequency trimmers. In the event that it should be advisable to re-align the intermediate frequency coils, it is absolutely essential that a 175 kilocycle oscillator and an output measuring device be used.

ALIGNMENT OF RECEIVER:

Because of the construction and thorough impregnation of the intermediate coils, the intermediate stages should rarely need re-tracking. Only when an intermediate coil has become defective due either to an open or burned out winding, should it be necessary to re-adjust the intermediate trimmers. Should this occur, it is necessary that an oscillator be used and the intermediate trimmers be adjusted at 175 kilocycles. To align the intermediate stages, connect the high side of the oscillator output to the grid circuit of the first detector, which is done by disconnecting the grid cap of the 224 first detector and connecting the high side of the test oscillator to the control grid of this tube. The ground side of the test oscillator should be connected to the ground post on the chassis. Set the oscillator at 175 kilocycles and adjust the output of the oscillator so that a convenient reading is obtained on the output meter. Be sure that the output from the oscillator is not so large that it will overload the second detector. If during the alignment the meter goes off scale, reduce the output of the test oscillator or adjust the receiver volume control.

The trimmers of the intermediate coils are accessible through the small holes in the top of the intermediate shield can. There are two trimmers to each intermediate coil. Align the grid trimmer of the first intermediate coil. After a maximum reading is obtained by adjusting the grid trimmer on the first intermediate, adjust the primary for maximum reading and then re-check the grid side to make certain the alignment of the secondary has not been changed by the adjustment of the primary. The same procedure is followed in aligning the second intermediate coils. After both intermediate coils are properly aligned the adjustment of the intermediate stage is complete and they should not be further disturbed.

Replace the grid cap on the first detector and connect the oscillator output leads to the antenna and ground posts of the receiver and set the oscillator at 1435 kilocycles. Then tune the receiver to 1435 kilocycles on the dial. It is important that the receiver be tuned to this point. If the receiver is out of the cabinet it will be necessary to use some temporary indicator so that the position 1435 kilocycles on the dial may be accurately located. (This indicator should be set so that when the variable condensers are at the maximum capacity stop the indicator points to the last line on the dial at the low frequency end.) Then track the variable condensers by adjusting the trimmer condensers in the following order: Oscillator, antenna and radio frequency - (reading from the front of the receiver toward the back, the variable condenser sections are: Oscillator, antenna and radio frequency). After the variable condensers have been properly tracked at 1435 kilocycles, adjust the oscillator to 1295 kilocycles. Tune the receiver to this frequency. Check alignment of the condensers at this point by bending the end plates of the rotors in and out, noting the change in reading on the output meter. If when the plates are bent in the reading is increased, it is an indication that that particular section requires more capacity and the end plate should be permanently bent in at this point; or, if when the end plate is bent away, the reading is increased, the end plate should be bent away permanently, as it is an indication that that particular section requires less capacity at that particular point. The variable condensers should be checked in this manner at 1295, 880, 650 and 550 kilocycles. These points have been chosen so as to take advantage of the slots in the end plates of the variable condensers. This procedure of bending plates should rarely be necessary on the oscillator section, as the plates of the oscillator section are especially designed to properly track over the broadcast spectrum, providing the antenna and radio frequency stages are correctly aligned.

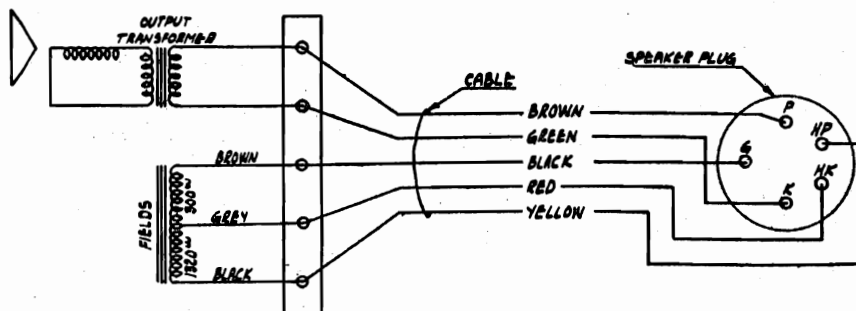

ELECTRO DYNAMIC SPEAKER:

The electro dynamic speaker has a tapped field winding - one section of which is 1320 ohms and is utilized as the second choke in the filter circuit. The other section, which is 300 ohms, is used to obtain the proper bias for the 247 tube, as well as acting as an additional filter choke.

MODEL DC
Electric Set

ANSLEY RADIO LABORATORIES

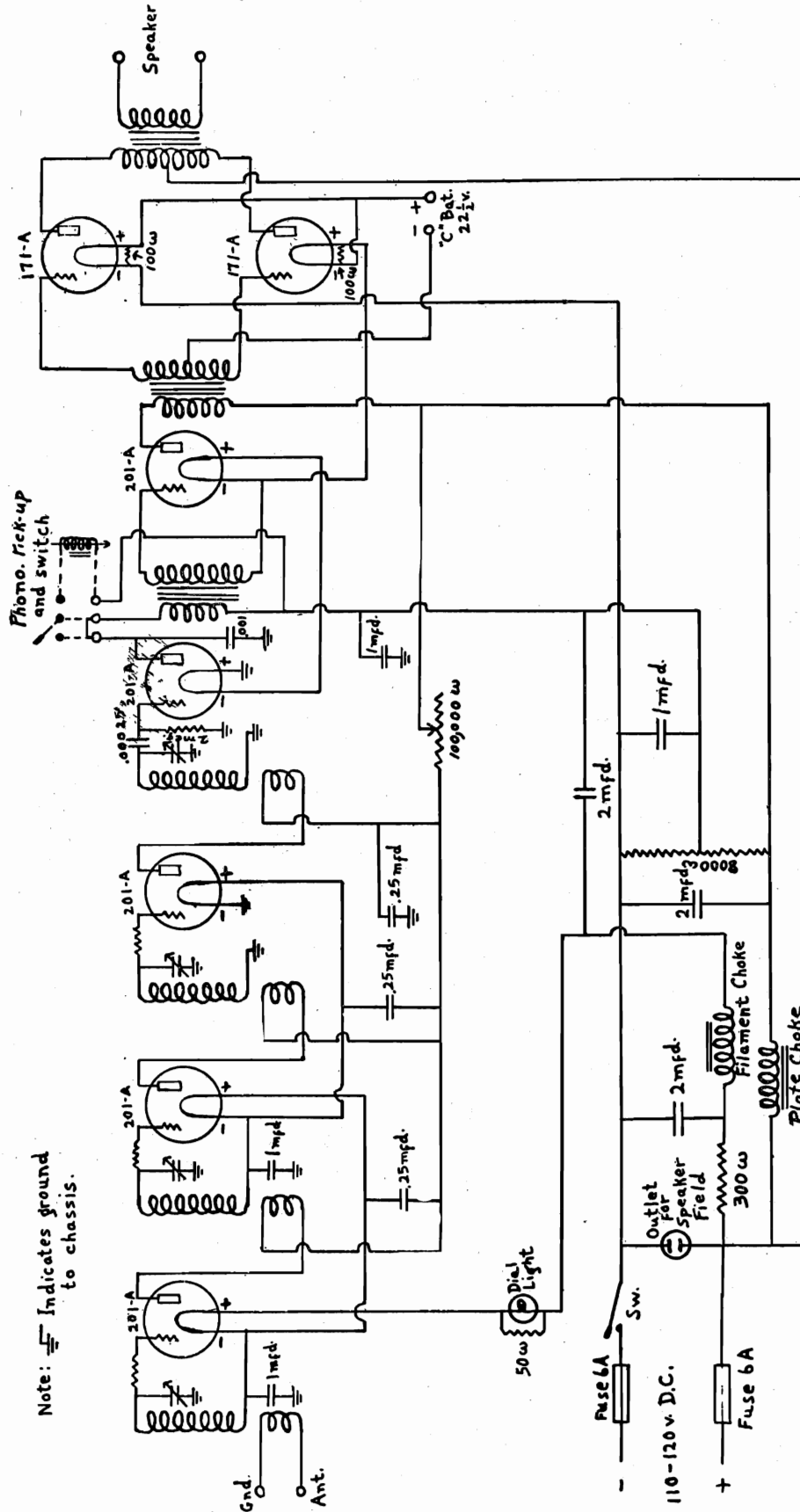

Note: $\text{---}\text{---}\text{---}$ Indicates ground to chassis.

Arthur C. Ansley
New York
6/23/30

ANSLEY BUILT RADIO
D.C. ELECTRIC SET

ANSLEY RADIO LABORATORIES

MODEL U-1

AC / DC

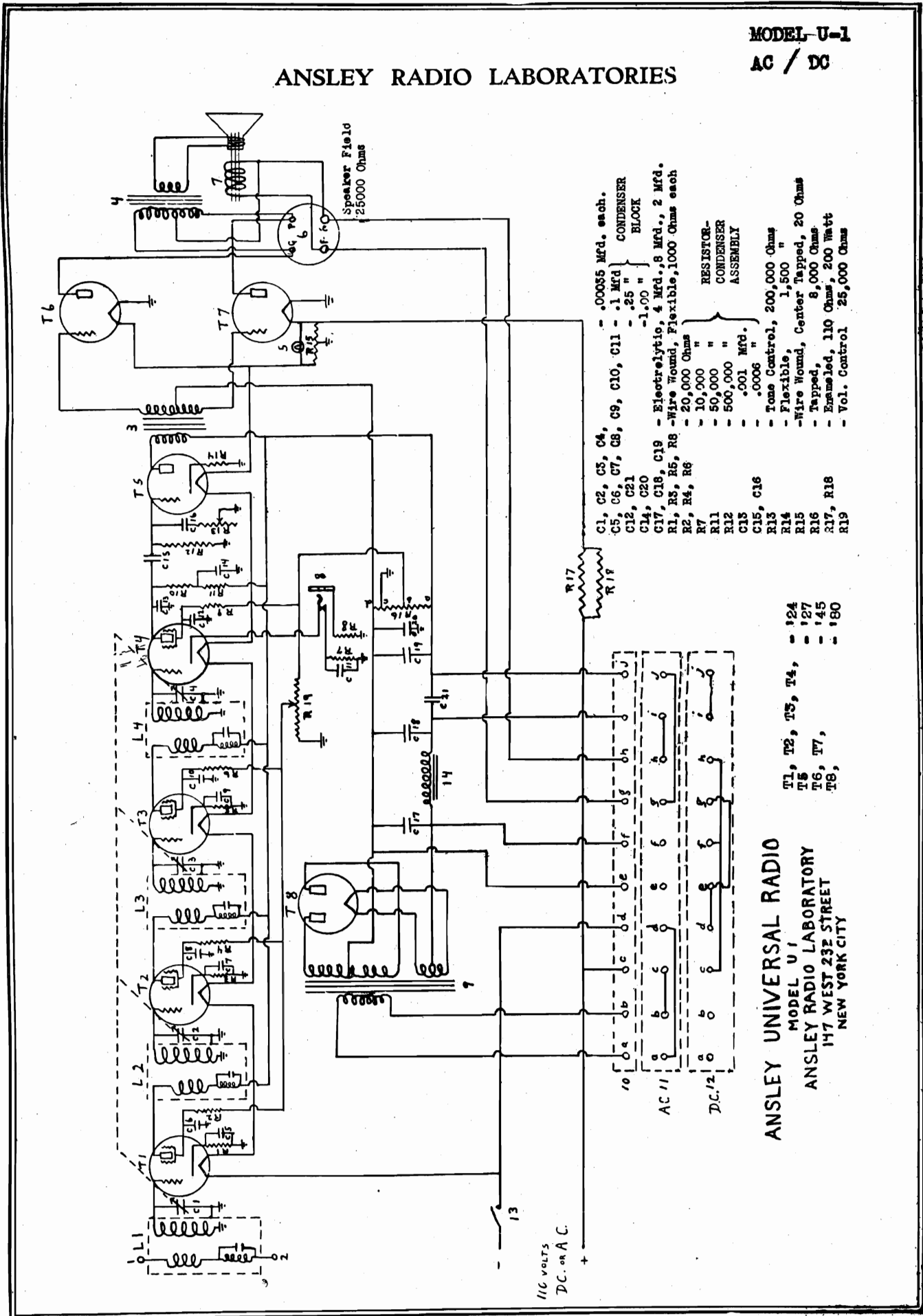

- C1, C2, C3, C4 - .00055 Mfd. each.
- C5, C6, C7, C8, C9, C10, C11 - .1 Mfd CONDENSER
- C12, C21 - .25 " BLOCK
- C14, C20 - 1.00 "
- C17, C18, C19 - Electrolytic, 4 Mfd., 8 Mfd., 2 Mfd.
- R1, R3, R5, R8 - Wire Wound, Flexible, 1000 Ohms each
- R2, R4, R6 - 20,000 Ohms
- R7 - 10,000 "
- R11 - 50,000 "
- R12 - 500,000 "
- R13 - .001 Mfd.
- R15, C16 - .0006 "
- R13 - Tone Control, 200,000 Ohms
- R14 - Flexible, 1,500 "
- R14 - Wire Wound, Center Tapped, 20 Ohms
- R15 - 8,000 Ohms
- R16 - Tapped, 8,000 Ohms
- R17, R18 - Enamelled, 110 Ohms, 200 Watt
- R19 - Vol. Control 25,000 Ohms

- T1, T2, T3, T4, - 124
- T5 - 127
- T6, T7, - 145
- T8, - 180

ANSLEY UNIVERSAL RADIO
 MODEL U-1
 ANSLEY RADIO LABORATORY
 117 WEST 232 STREET
 NEW YORK CITY

APPEL-HENDERSON

MODEL Silver King DC
Combination

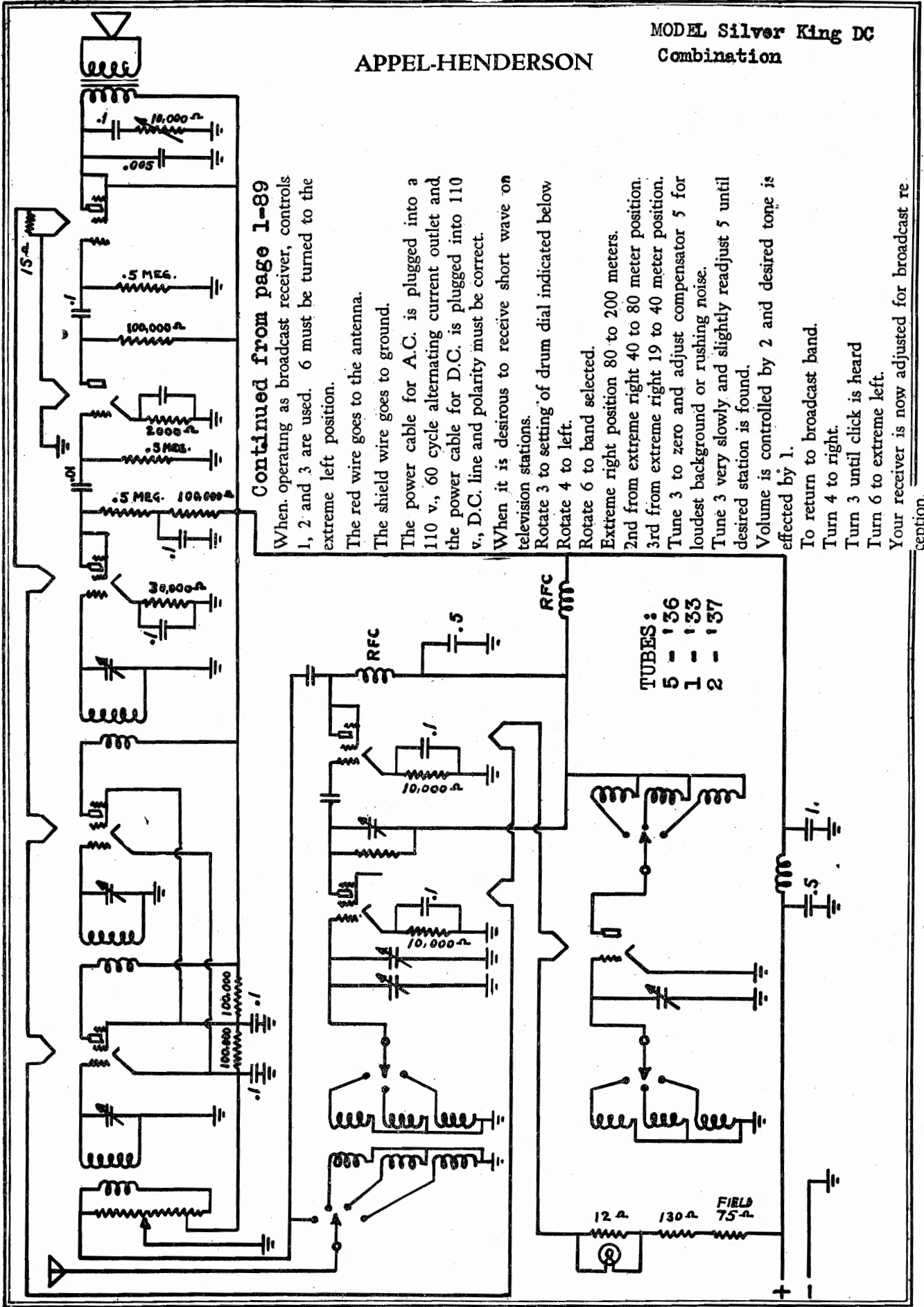

Continued from page 1-89
 When operating as broadcast receiver, controls 1, 2 and 3 are used. 6 must be turned to the extreme left position.

The red wire goes to the antenna.

The shield wire goes to ground.

The power cable for A.C. is plugged into a 110 v., 60 cycle alternating current outlet and the power cable for D.C. is plugged into 110 v., D.C. line and polarity must be correct.

When it is desirable to receive short wave on television stations.

Rotate 3 to setting of drum dial indicated below

Rotate 4 to left.

Rotate 6 to band selected.

Extreme right position 80 to 200 meters.
 2nd from extreme right 40 to 80 meter position.

3rd from extreme right 19 to 40 meter position.

Tune 3 to zero and adjust compensator 5 for loudest background or rushing noise.

Tune 3 very slowly and slightly readjust 5 until desired station is found.

Volume is controlled by 2 and desired tone is effected by 1.

To return to broadcast band.

Turn 4 to right.

Turn 3 until click is heard

Turn 6 to extreme left.

Your receiver is now adjusted for broadcast reception.

MODEL 4-Tube
Portable
MODEL 5-Tube
Battery Midget

APPEL-HENDERSON

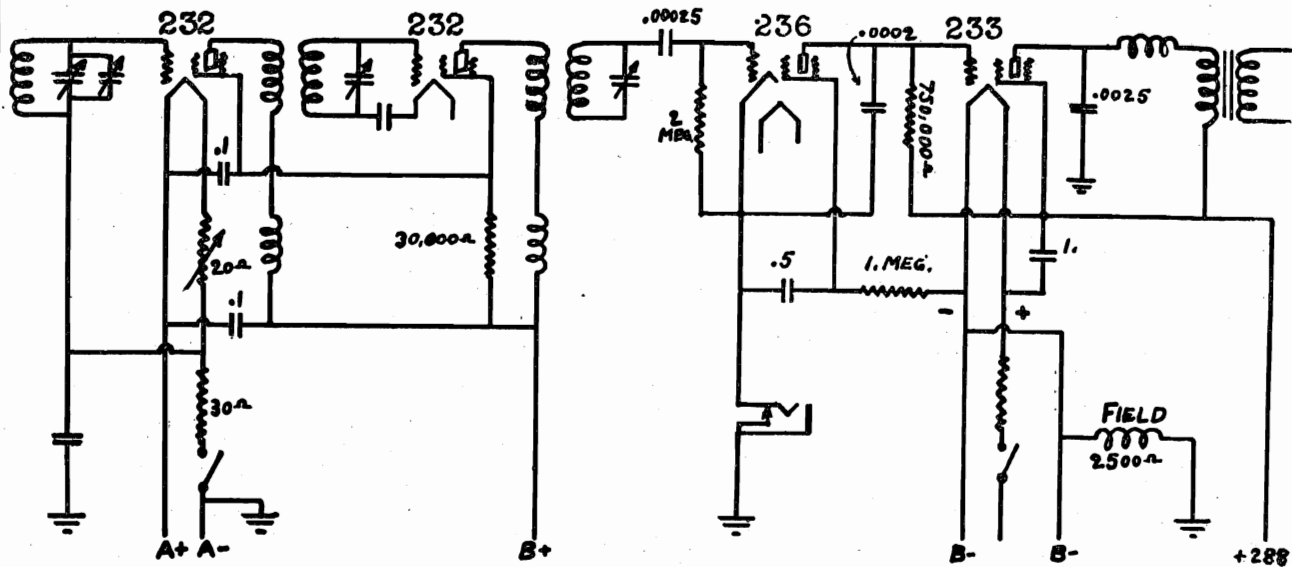

4 TUBE PORTABLE RECEIVER.

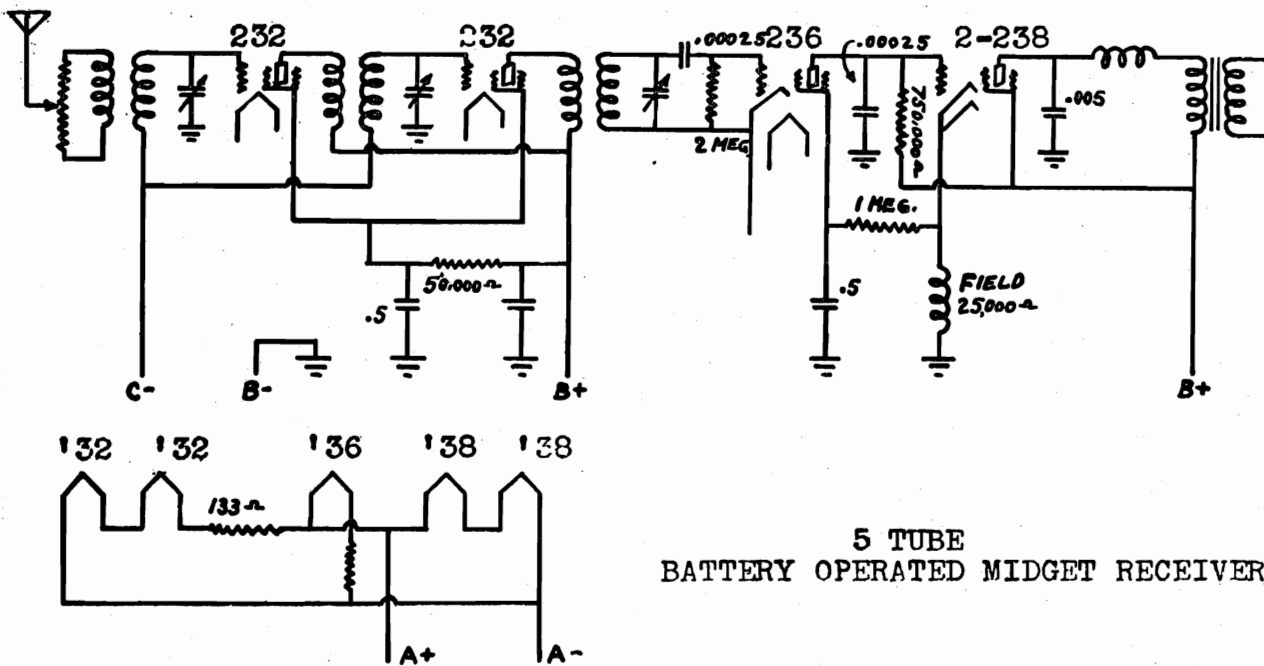

5 TUBE
BATTERY OPERATED MIDGET RECEIVER.

MODEL 46, 47, 53

Data

ATWATER KENT MFG. CO.

Model 46, 47 and 53 Receivers

General Description

Model 46 is similar to Model 43, except that the power unit is enlarged to provide adequate plate supply for the 171A-type tubes used in the 2nd A.F. stage. Also, the voltage regulator is not used, and the condensers in the power unit are contained in a separate replaceable section. Model 53 is a Model 46 with a type F-2C electro dynamic speaker mounted in a twenty six inch high metal cabinet.

Model 47 is similar to Model 46, but has four stages of R. F. amplification, with double R.F. transformers, thus providing greater sensitivity and selectivity.

The continuity tests given on page 103 may be applied to the receiver chassis of Models 46 and 53. The same tests may be applied to Model 47, with additional tests for the 4th R.F. socket contacts, which should give the same readings as the 2nd and 3rd R.F. sockets.

Special instructions for servicing the power unit in these three models are given below

Power Units in Models 46, 47 and 53

Apply the continuity test given in the table on page 104. If any one of the condensers is shorted or leaky, replace the condenser assembly. If the power transformer, filter-choke or output transformer is defective, replace the main sealed container, salvaging all other parts.

Replacing Condenser Assembly

Release panel assembly from power unit and remove panel-mounting strip by taking out the machine screw at each end. Unscrew two bolts holding the condenser assembly retaining-spring and take out the spring and supporting strip. Cut the three leads (white, blue, and green-yellow tracer), which connect between the condenser assembly and the transformer-choke assembly, at about the mid-point of each lead. Unsolder black lead from ground lug. Unsolder yellow lead and two black-red tracers leads from panel terminals. Unsolder leads at contacts of speaker-plug socket and socket 2Aa. Pull these leads up an inch or so through the hole in the socket-mounting angle and push the cable to one side

of the unit to allow room for removal of the condenser assembly. Take-out the assembly, pulling the blue M2 lead up through the cable covering.

Insert a new condenser assembly, reversing above procedure. Insulate the joints on the blue, white, and green-yellow tracer leads which connect the condenser assembly to the transformer-choke assembly

Replacing Transformer-Choke Assembly

Unsolder leads from socket plates at both ends of container and remove these sockets. Unsolder primary winding leads at points where they connect to the toggle switch and to one side of the 110-volt cable respectively. Release panel assembly from unit. Unscrew panel-mounting strip and condenser-retaining spring. Pull the primary leads, the yellow-black tracer output leads and the brown P2Aa lead (No. 18 wire) up through the cable covering. Cut the three leads (white, blue, and green-yellow tracer) which connect the transformer-choke assembly and the condenser assembly. Cut each lead at about the mid-point. Unsolder the six filament winding leads, the brown +B, 2A lead, and the white +B, R.F. lead from terminals on panel assembly. Unsolder black lead from ground lug. Remove the condenser and panel assemblies

Substitute a new transformer-choke assembly, mount the salvaged parts and connect exactly like the original, reversing procedure outlined above

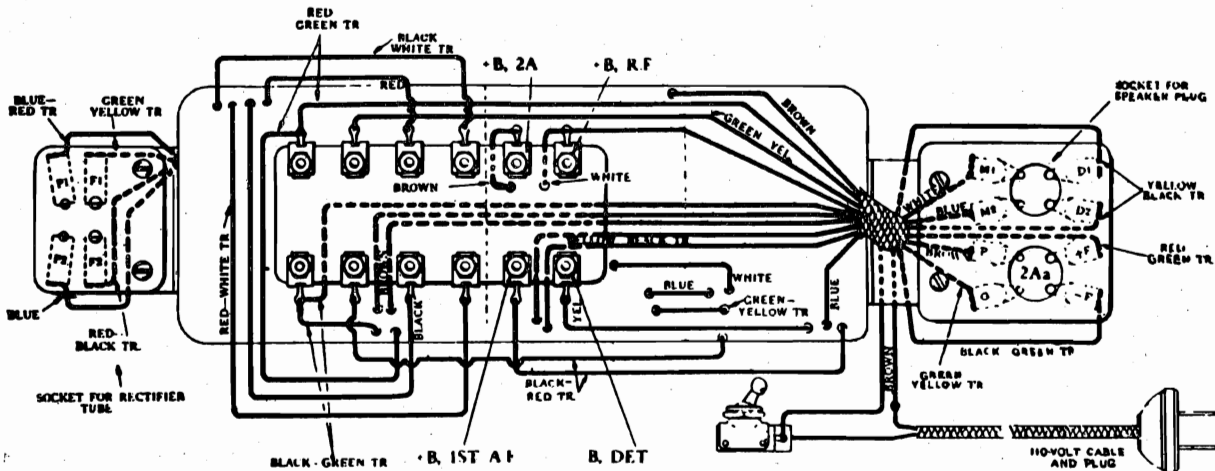
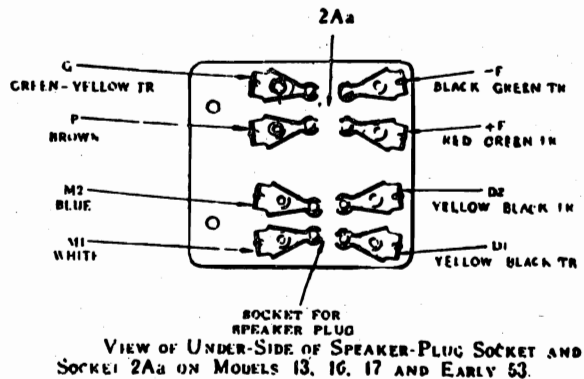

This view shows the panel assembly moved to the left of its normal position. The replaceable condenser assembly is in the right hand end of the container. A black lead from the condenser assembly and a green lead from the transformer assembly are connected to a ground lug under the left hand panel mounting angle. (No. 18 wire) instead of yellow-with-black-tracer

MODEL 82-Q
1st Type
Below serial
2,550,940

ATWATER KENT MFG. CO.

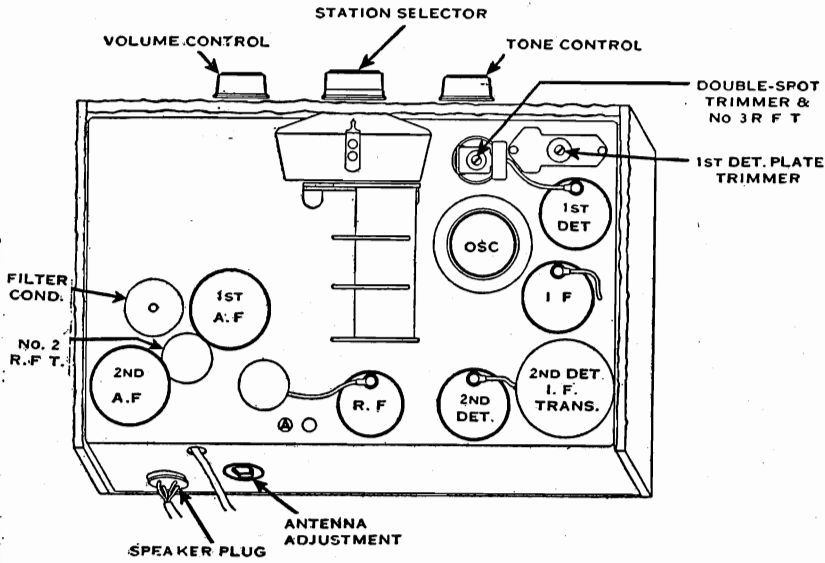

- RF Bypass # 1
21170
- RF Bypass # 2
15262
- RF Bypass #3
19150
- RF Bypass # 4
15262
- Tone Control
16490

TOP VIEW OF MODEL 82-Q.

By-pass Condensers in Model 82-Q

R. F. By-pass No. 1

- 1—Not used.
- 2—Quality condenser.
- 3—2nd-detector grid-circuit by-pass.

R. F. By-pass No. 2

- 4—+B filter condenser.
- 5—R. F. grid-circuit by-pass.
- 6—R. F.—I. F. screen by-pass.
- 7—1st-detector grid-circuit by-pass.

R. F. By-pass No. 3

- 8—2nd-detector filter condenser.
- 9—2nd-detector—1st-A. F. coupling condenser.
- 10—Tracking condenser.

R. F. By-pass No. 4

- 11—2nd-detector screen by-pass.
- 12—1st-A. F. filter condenser.
- 13—1st-detector screen by-pass.
- 14—I. F. plate filter condenser.

Tone-control Condenser

- 15—Tone condenser.
- 16—Tone condenser.
- 17—Tone condenser.
- 18—Not used.

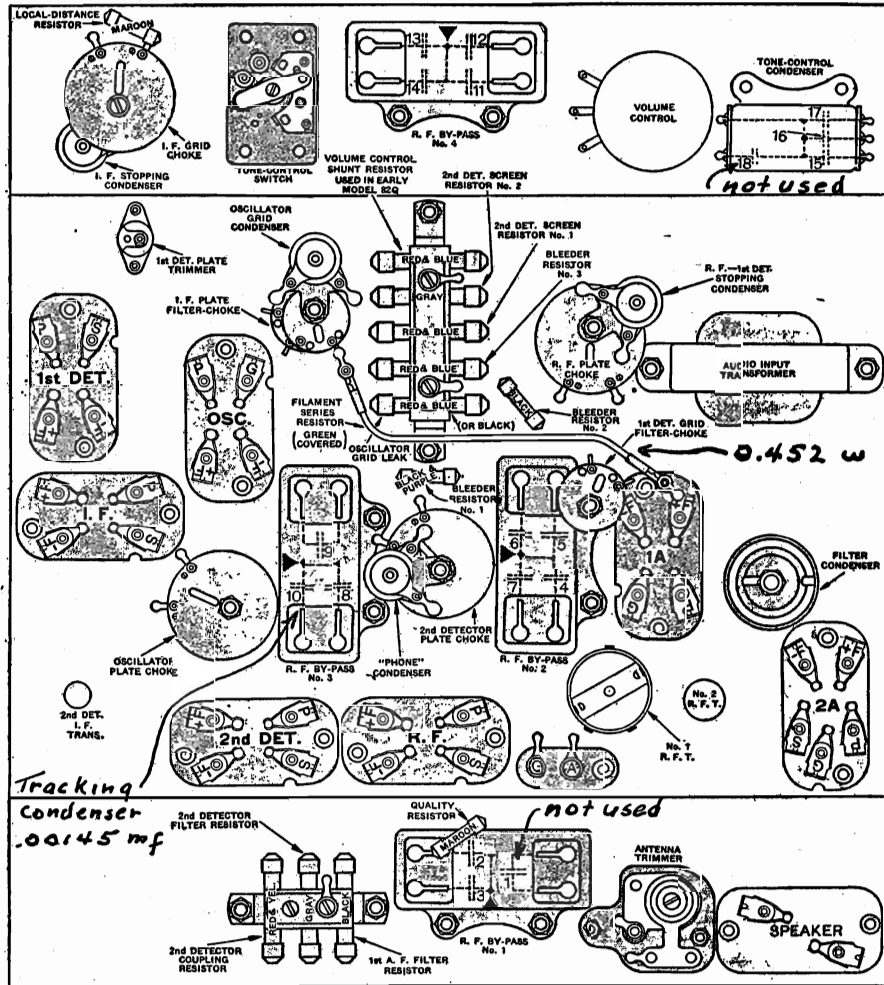

CHART OF MODEL 82-Q.

ATWATER KENT MFG. CO.

VOLTAGE DATA

VOLTAGE TABLE

FOR MODEL 80, 81, 82, 82-D, 82-Q, 83, 84, 84-D, 84-Q, 85, 85-Q, 86, 87 and 89

The voltages listed in this table are only approximate, and are measured values, not actual operating values. Turn volume control to maximum.

Use 250-volt scale of a 1000-ohm-per-volt D. C. voltmeter.

All plate, screen and grid measurements are made from cathode in heater-type tube, and from — F in plain-filament-type tube.

When replacing a tubular resistor, use a resistor of the same color as the defective unit. However, if a resistor has been removed, or its identification destroyed, replace it with a resistor having the color that is specified in the diagram for that set.

the same color as the defective unit. However, if a resistor has been removed, or its identification destroyed, replace it with a resistor having the color that is specified in the diagram for that set.

	MODEL 80	MODEL 81	MODEL 82	MODEL 82-D	MODEL 82-Q	MODEL 83	MODEL 84	MODEL 84-D	MODEL 84-Q	MODEL 85	MODEL 85-Q	MODEL 86	MODEL 87	MODEL 89
LINE VOLTAGE	110	110	110	110	110	110	110	110	120	110	110	115	110	110
TOTAL "B" VOLTAGE	125	125	125	125	125	125	125	125	125	125	125	125	125	125
R. F. TUBE**	5.5 125 75 SMALL	5.5 125 75 SMALL	5.5 125 75 SMALL	5.5 125 75 SMALL	5.5 125 75 SMALL	5.5 125 75 SMALL	5.5 125 75 SMALL	5.5 125 75 SMALL	5.5 125 75 SMALL	5.5 125 75 SMALL	5.5 125 75 SMALL	5.5 125 75 SMALL	5.5 125 75 SMALL	5.5 125 75 SMALL
1ST DET. TUBE†	2.4 2.4 2.4 2.4	2.4 2.4 2.4 2.4	2.4 2.4 2.4 2.4	2.4 2.4 2.4 2.4	2.4 2.4 2.4 2.4	2.4 2.4 2.4 2.4	2.4 2.4 2.4 2.4	2.4 2.4 2.4 2.4	2.4 2.4 2.4 2.4	2.4 2.4 2.4 2.4	2.4 2.4 2.4 2.4	2.4 2.4 2.4 2.4	2.4 2.4 2.4 2.4	2.4 2.4 2.4 2.4
I. F. TUBE	2.4 2.4 2.4 2.4	2.4 2.4 2.4 2.4	2.4 2.4 2.4 2.4	2.4 2.4 2.4 2.4	2.4 2.4 2.4 2.4	2.4 2.4 2.4 2.4	2.4 2.4 2.4 2.4	2.4 2.4 2.4 2.4	2.4 2.4 2.4 2.4	2.4 2.4 2.4 2.4	2.4 2.4 2.4 2.4	2.4 2.4 2.4 2.4	2.4 2.4 2.4 2.4	2.4 2.4 2.4 2.4
2ND DET. TUBE	2.4 2.4 2.4 2.4	2.4 2.4 2.4 2.4	2.4 2.4 2.4 2.4	2.4 2.4 2.4 2.4	2.4 2.4 2.4 2.4	2.4 2.4 2.4 2.4	2.4 2.4 2.4 2.4	2.4 2.4 2.4 2.4	2.4 2.4 2.4 2.4	2.4 2.4 2.4 2.4	2.4 2.4 2.4 2.4	2.4 2.4 2.4 2.4	2.4 2.4 2.4 2.4	2.4 2.4 2.4 2.4
1ST A. F. TUBE	2.4 2.4 2.4 2.4	2.4 2.4 2.4 2.4	2.4 2.4 2.4 2.4	2.4 2.4 2.4 2.4	2.4 2.4 2.4 2.4	2.4 2.4 2.4 2.4	2.4 2.4 2.4 2.4	2.4 2.4 2.4 2.4	2.4 2.4 2.4 2.4	2.4 2.4 2.4 2.4	2.4 2.4 2.4 2.4	2.4 2.4 2.4 2.4	2.4 2.4 2.4 2.4	2.4 2.4 2.4 2.4
2ND A. F. TUBE	2.4 2.4 2.4 2.4	2.4 2.4 2.4 2.4	2.4 2.4 2.4 2.4	2.4 2.4 2.4 2.4	2.4 2.4 2.4 2.4	2.4 2.4 2.4 2.4	2.4 2.4 2.4 2.4	2.4 2.4 2.4 2.4	2.4 2.4 2.4 2.4	2.4 2.4 2.4 2.4	2.4 2.4 2.4 2.4	2.4 2.4 2.4 2.4	2.4 2.4 2.4 2.4	2.4 2.4 2.4 2.4
Osc. TUBE	2.4 2.4 2.4 2.4	2.4 2.4 2.4 2.4	2.4 2.4 2.4 2.4	2.4 2.4 2.4 2.4	2.4 2.4 2.4 2.4	2.4 2.4 2.4 2.4	2.4 2.4 2.4 2.4	2.4 2.4 2.4 2.4	2.4 2.4 2.4 2.4	2.4 2.4 2.4 2.4	2.4 2.4 2.4 2.4	2.4 2.4 2.4 2.4	2.4 2.4 2.4 2.4	2.4 2.4 2.4 2.4
CONTROL TUBE	2.4 2.4 2.4 2.4	2.4 2.4 2.4 2.4	2.4 2.4 2.4 2.4	2.4 2.4 2.4 2.4	2.4 2.4 2.4 2.4	2.4 2.4 2.4 2.4	2.4 2.4 2.4 2.4	2.4 2.4 2.4 2.4	2.4 2.4 2.4 2.4	2.4 2.4 2.4 2.4	2.4 2.4 2.4 2.4	2.4 2.4 2.4 2.4	2.4 2.4 2.4 2.4	2.4 2.4 2.4 2.4

* The measured oscillator grid voltage will vary dependent on the capacity of the voltmeter leads. In some cases, the presence of the leads will stop oscillation and no reading will be secured for grid bias. In other cases, the reading will be only slight, or it may be as high as 10 volts.
 **This includes the 1st, 2nd and 3rd R. F. tubes in Model 81. †This is the detector tube in Model 81.

MODEL 84, 84-F CHARTS

MODELS 84, 84-F
Early and Late

ATWATER KENT MFG. CO.

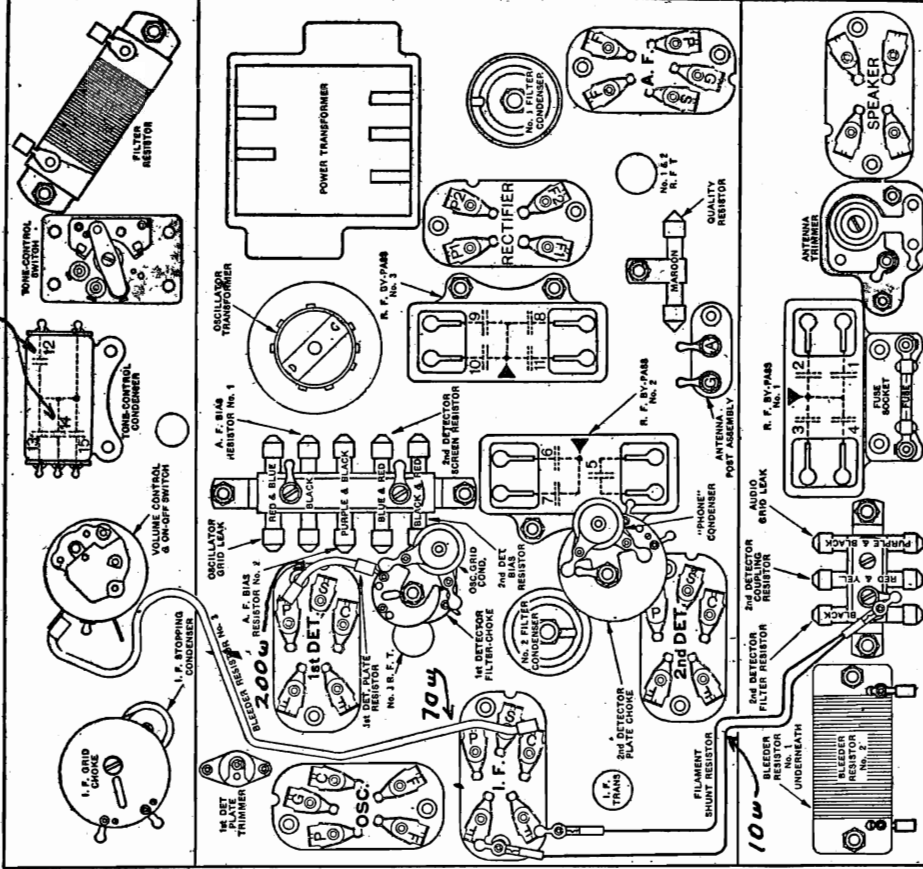

CHART OF LATE-TYPE MODEL 84, 84-F.

Some late-type Model 84, 84-F receivers have slightly different oscillator transformers and connections than indicated in the diagram. When servicing such sets, carefully note and adhere to the original method of wiring. A flexible type 1st-detector bias resistor (not shown above) is connected from condenser 9 to condenser 3.

- 100 Volts.**
- Tone-control Condenser (used only in late type)
 - 12—Not used.
 - 13—Tone-control condenser.
 - 14—Not used.
 - 15—Tone-control condenser.

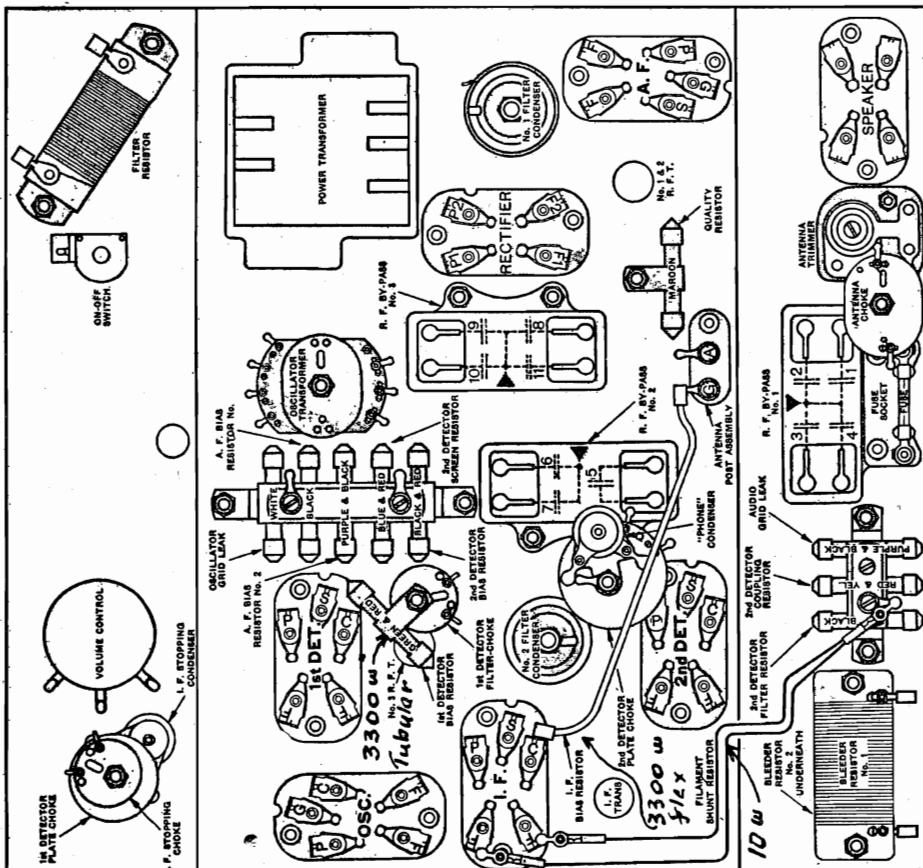

CHART OF EARLY-TYPE MODEL 84, 84-F.

In some early-type Model 84, 84-F, the 1st-detector bias resistor is a flexible type, and the quality resistor is wire-wound. These are both superseded by the tubular resistors indicated above. The filter-resistor at top-right is NOT used in any Model 84-F.

- 400 Volts**
- R. F. By-pass No. 1
 - 1—2nd-detector filter condenser.
 - 2—Quality condenser
 - 3—I. F. bias by-pass.
 - 4—A. F. bias by-pass.

- By-pass Condensers in Model 84, 84-F.**
- R. F. By-pass No. 2
 - 5—2nd-detector—A. F. coupling, condenser
 - 6—Tracking condenser
 - 7—2nd-detector bias by-pass.
- 400 Volts**

ATWATER KENT MFG. CO.

MODEL 84-Q
Early and Late

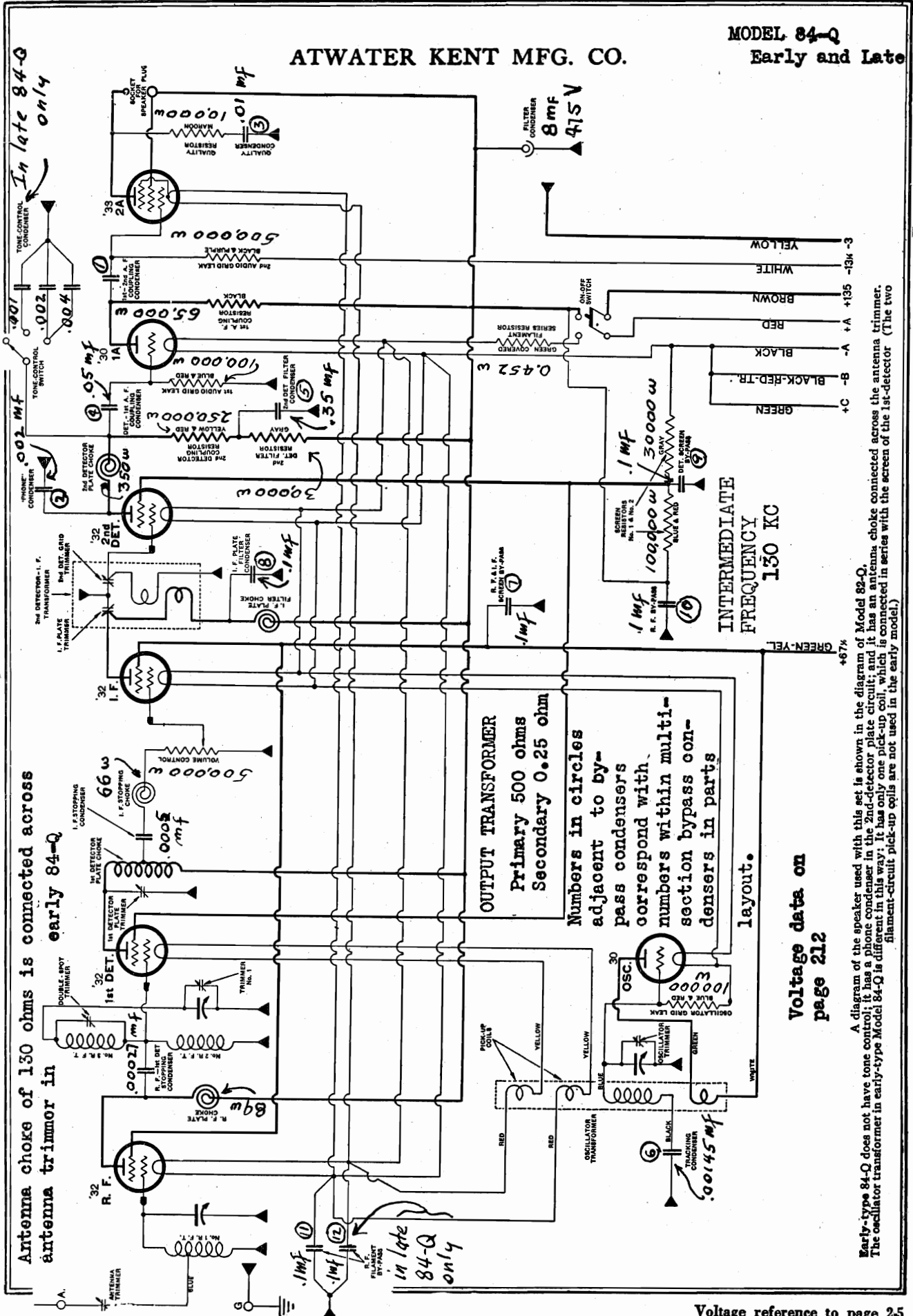

Antenna choke of 130 ohms is connected across antenna trimmer in early 84-Q

Antenna trimmer in late 84-Q only

OUTPUT TRANSFORMER
Primary 500 ohms
Secondary 0.25 ohm
Numbers in circles adjacent to by-pass condensers within multi-section bypass condensers in parts layout.

INTERMEDIATE FREQUENCY 150 KC

Voltage data on page 212

A diagram of the speaker used with this set is shown in the diagram of Model 82-Q, and it has a phone condenser in the 2nd-detector plate circuit; and it has only one pick-up coil, which is connected in series with the screen of the 1st-detector (The two filament-circuit pick-up coils are not used in the early model.)

MODEL 84-Q
Early and Late.

ATWATER KENT MFG. CO.

In late 84-Q only

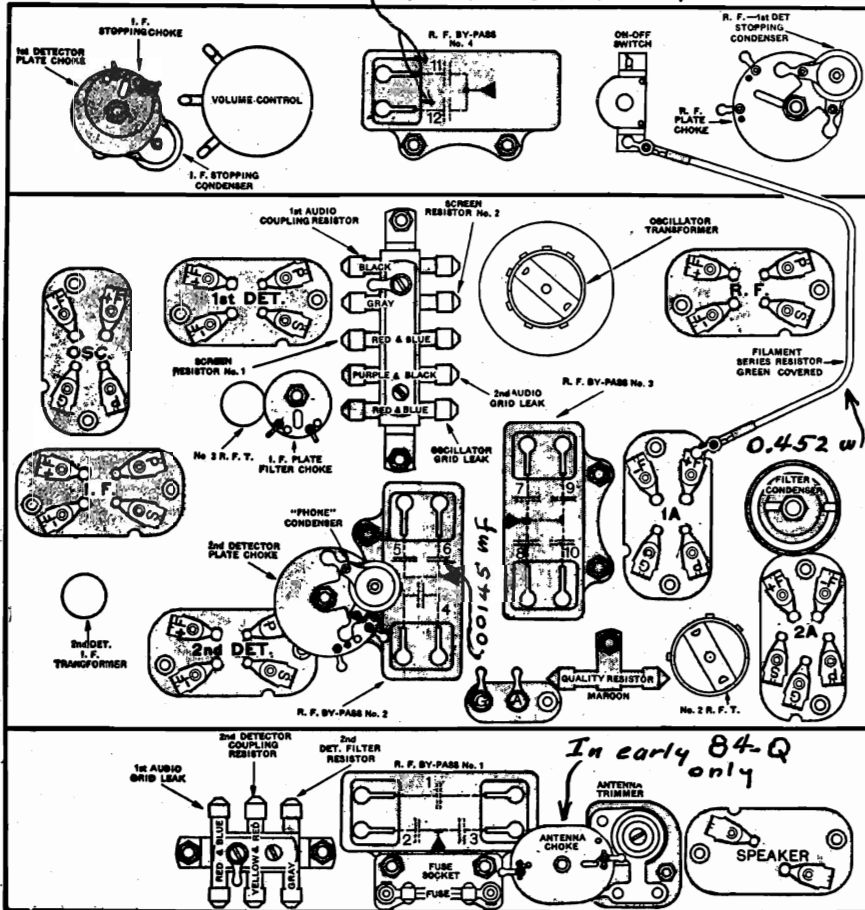

MODEL 84-Q

By-pass Condensers in Model 84-Q

R. F. By-pass No. 1

- 1—1st-2nd A. F. coupling condenser
- 2—Phone condenser.
- 3—Quality condenser.

400 Volts

R. F. By-pass No. 2

- 4—2nd-detector—1st-A F. coupling condenser.
- 5—2nd-detector filter condenser.
- 6—Tracking condenser.

400 Volts

R. F. By-pass No. 3

- 7—R. F.-I. F. screen by-pass.
- 8—I. F. plate filter condenser.
- 9—1st-detector—2nd-detector screen by-pass.
- 10—+B filter condenser.

400 Volts

R. F. By-pass No. 4 (Later 84-Q only)

- 11—R. F. filament by-pass.
- 12—R. F. filament by-pass.

400 Volts

Tone control is 100 V.

CHART OF MODEL 84-Q. (EARLY TYPE WITHOUT TONE CONTROL.)

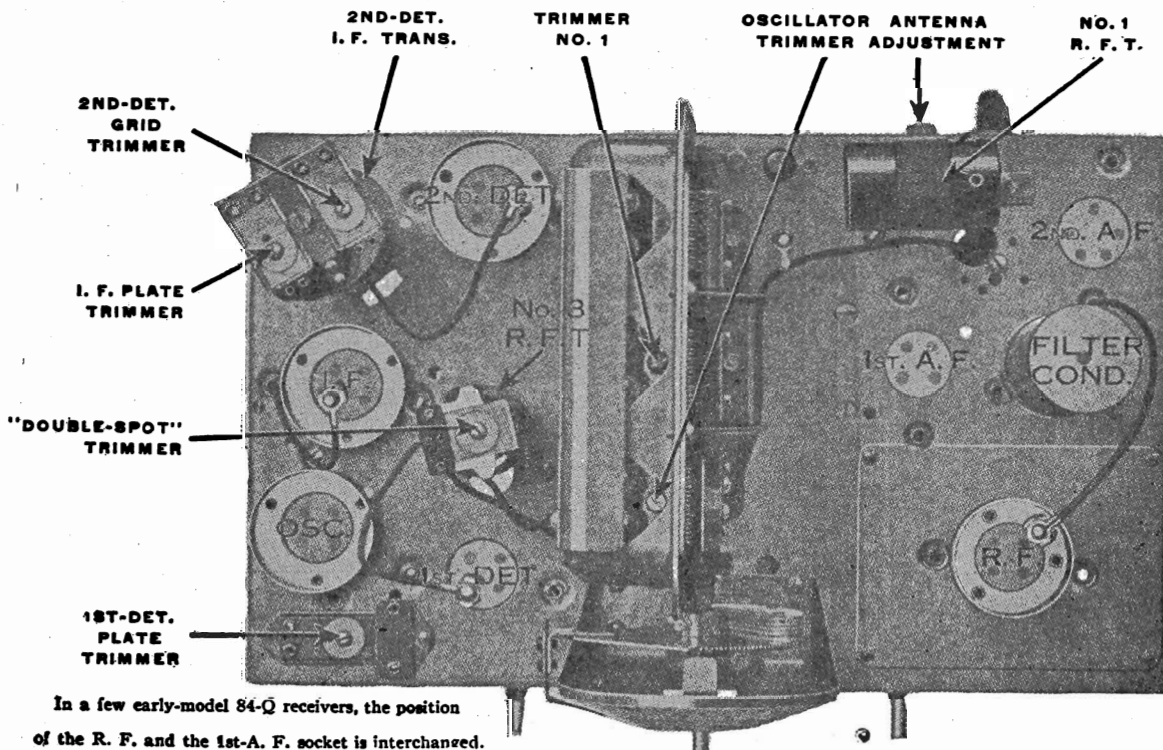

In a few early-model 84-Q receivers, the position of the R. F. and the 1st-A. F. socket is interchanged.

ATWATER KENT MFG. CO.

MODEL 85-Q
1st Type
Below serial
163767

Numerals within circles adjacent to the bypass condensers correspond with the numbers shown upon the multi-section bypass condensers illustrated in the parts layout on the next page.

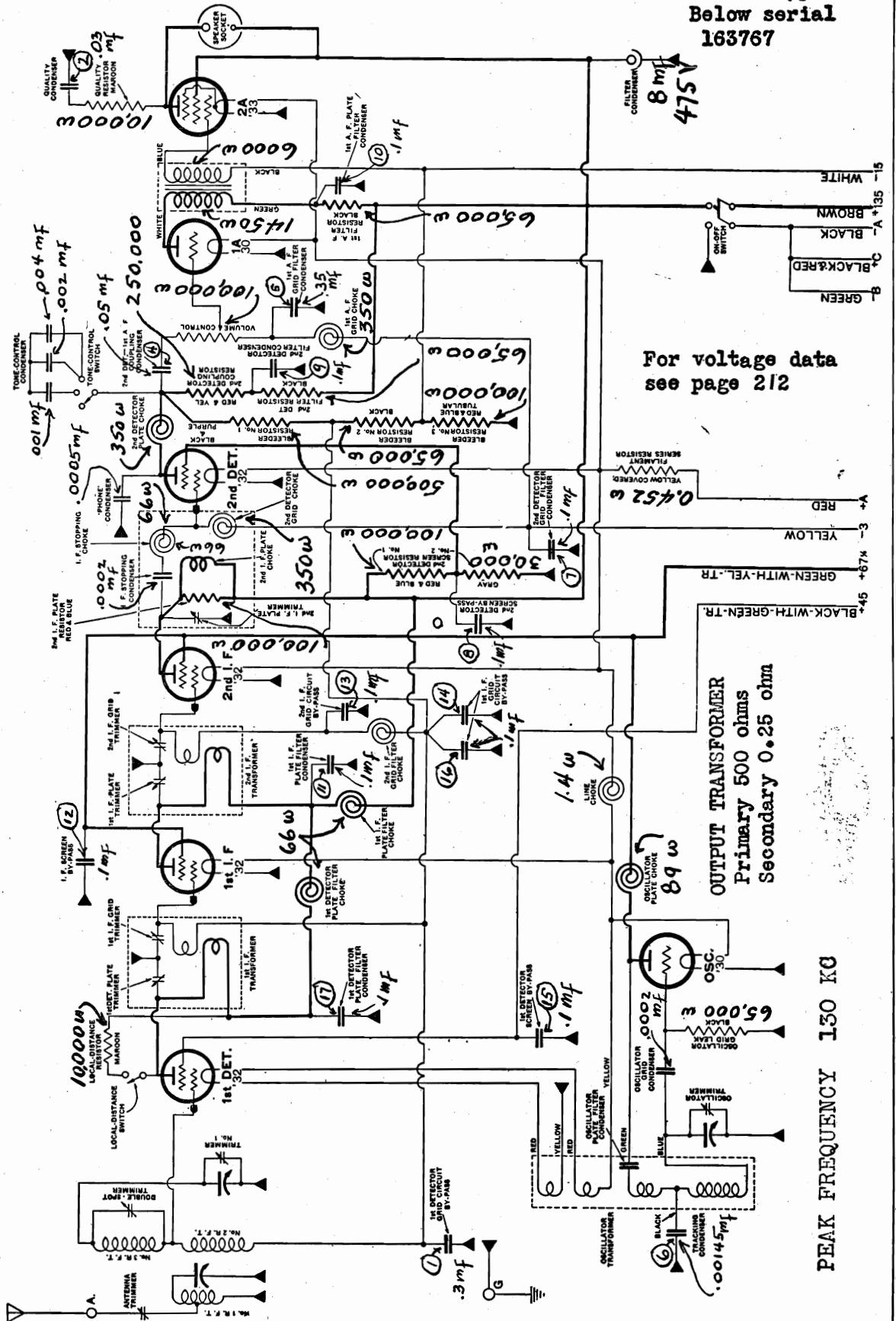

For voltage data see page 212

OUTPUT TRANSFORMER
Primary 500 ohms
Secondary 0.25 ohm

PEAK FREQUENCY 130 KC

Voltage reference to page 2-5

MODEL 85-Q
1st Type
Below serial
163767

ATWATER KENT MFG. CO.

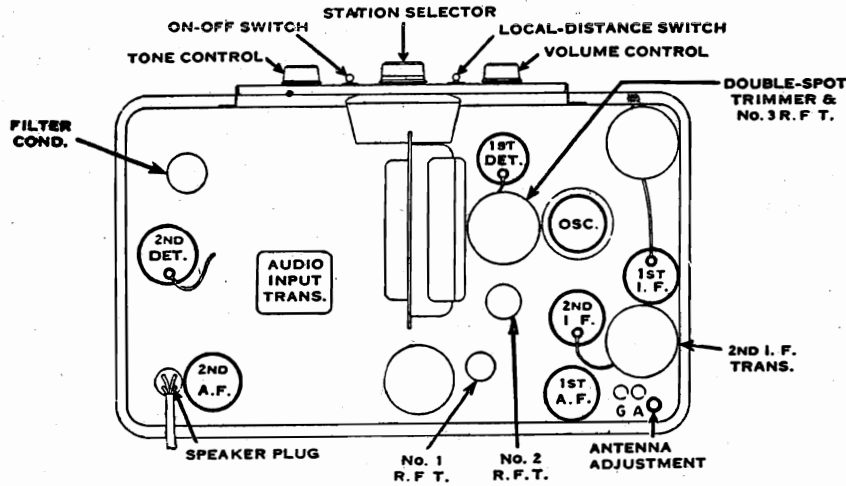

TOP VIEW OF MODEL 85-Q.

The circle in the top right corner indicates the shield for the coupling unit between the 1st-detector and the 1st-I. F. tubes. The circle in the bottom center is the shield covering the coupling unit between the 2nd-I. F. and the 2nd-detector tubes.

CONDENSERS

- RF Bypass # 1 # 19980 400 volts
- RF Bypass # 2 # 19150 400 volts
- RF Bypass # 3 # 15262 400 volts
- RF Bypass # 4 # 15262 400 volts
- RF Bypass # 5 # 15262 400 volts

Tone Control condenser # 16490 100 volts

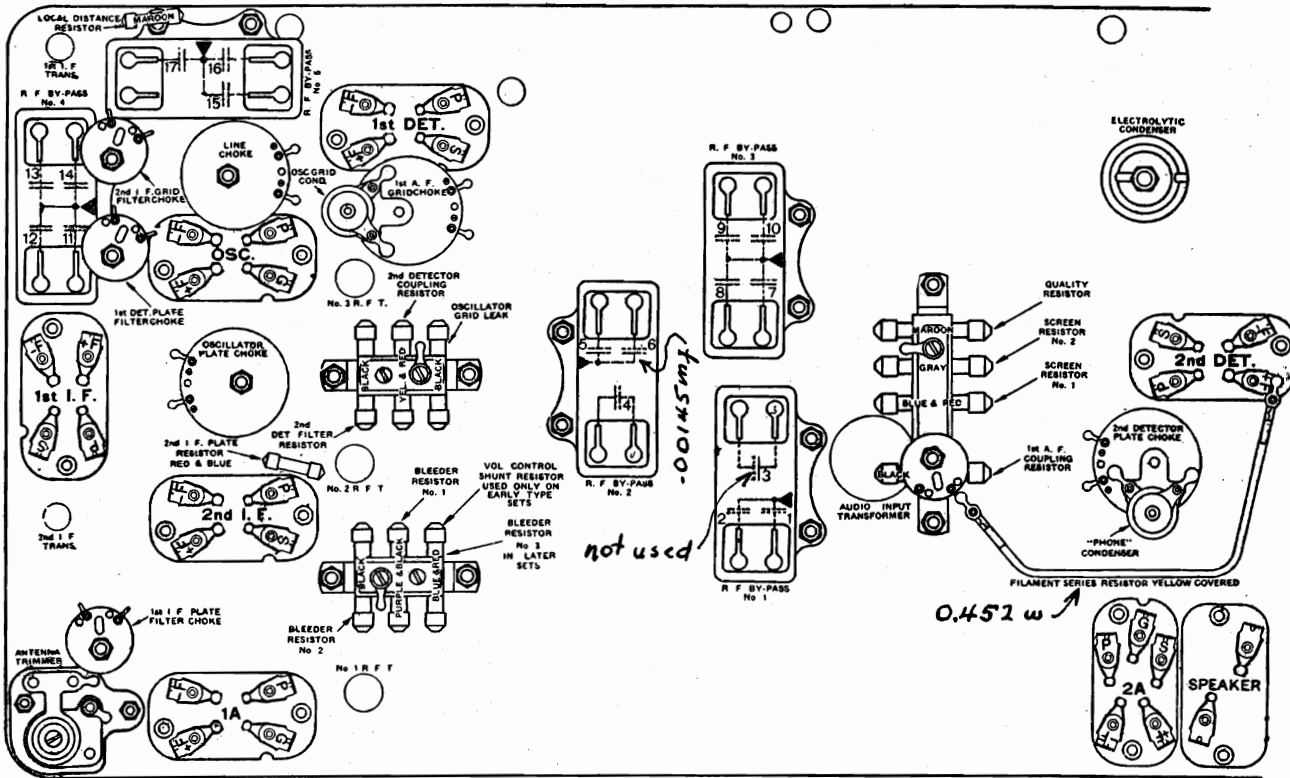

By-pass Condensers in Model 85-Q.

- | R. F. By-pass No. 1 | R. F. By-pass No. 2 | R. F. By-pass No. 3 | R. F. By-pass No. 4 | R. F. By-pass No. 5 |
|--------------------------------------|--|---------------------------------------|--------------------------------------|---|
| 1—1st-detector grid-circuit by-pass. | 4—2nd-detector—1st-A. F. coupling condenser. | 7—2nd-detector grid filter condenser. | 11—1st-I. F. plate filter condenser. | 15—1st-detector screen by-pass. |
| 2—Quality condenser. | 5—1st-A. F. grid filter condenser. | 8—2nd-detector screen by-pass. | 12—I. F. screen by-pass. | 16—1st-I. F. grid-circuit by-pass. |
| 3—Not used. | 6—Tracking condenser. | 9—2nd-detector filter condenser. | 13—2nd-I. F. grid-circuit by-pass. | 17—1st-detector plate filter condenser. |
| | | 10—1st-A. F. plate filter condenser. | 14—1st-I. F. grid-circuit by-pass. | |

MODEL 86, 86-F
1st Type
Below serial
5,876,861

ATWATER KENT MFG. CO.

FILTER CONDENSER. The two small numbers adjacent to the filter condenser representations correspond with the numbers upon the condenser. The capacity between terminal (1) and the center stud is 3. mfd and between terminal (4) and the center stud it is 4. mfd.

BYPASS CONDENSER. The numbers in circles adjacent to the bypass condensers correspond with the designations within the multi-section units shown on the parts layout.

RF Bypass # 1	1.	.01 mfd	400 volts	2.	.03 mfd	400 volts	# 21170
	3.	.3 mfd	400 volts	4.	.0006 mfd	400 volts	
RF Bypass # 2	5.	.3 mfd	200 volts	6.	.02 mfd	200 volts	# 23330
	7.	.04 mfd	200 volts	8.	.05 mfd	200 volts	
RF Bypass # 3	9.	.1 mfd	400 volts	10.	.1 mfd	400 volts	# 15262
	11.	.1 mfd	400 volts	12.	.1 mfd	400 volts	
Tone Control	13.	.001 mfd	100 volts	14.	.003 mfd	100 volts	# 20010
	15.	.1 mfd	100 volts	16.	.1 mfd	100 volts	

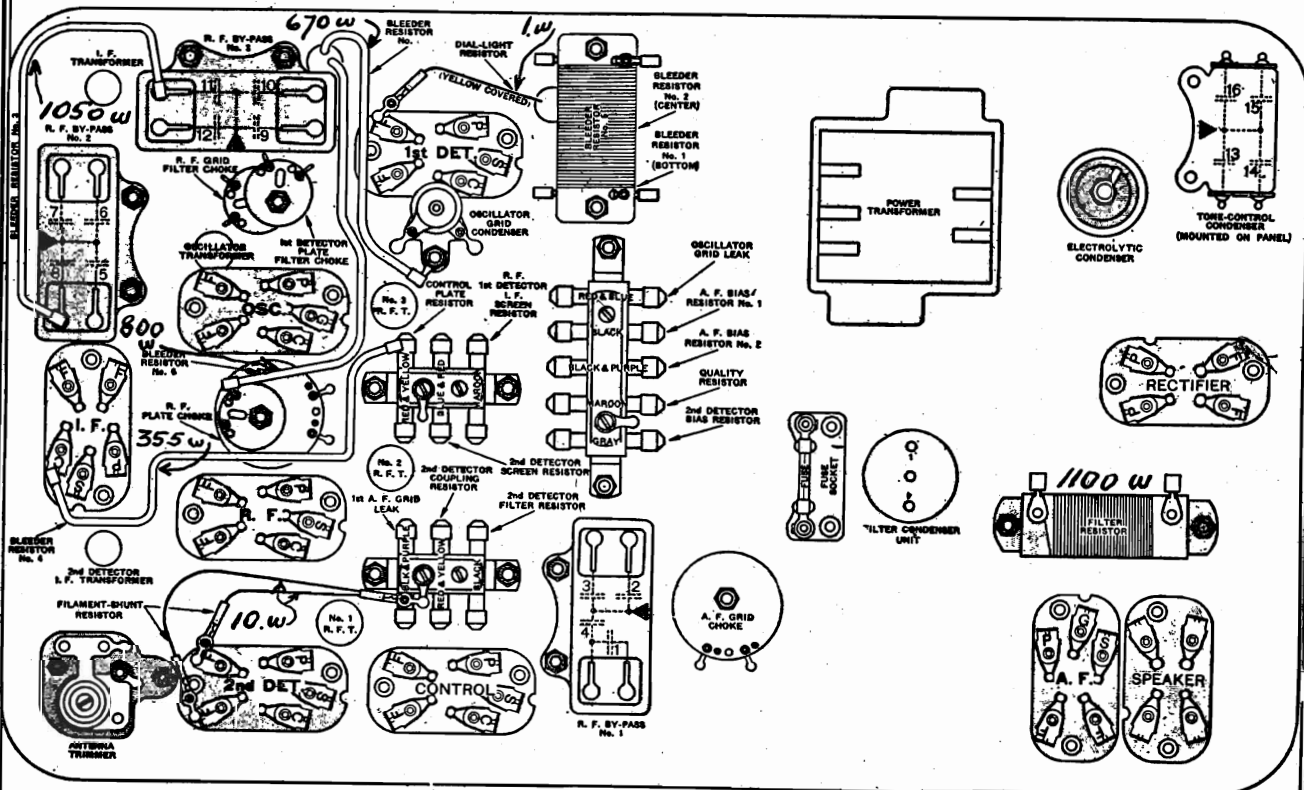

CHART OF MODEL 86, 86-F.

The filter resistor is not used in Model 86-F.

By-pass Condensers in Model 86, 86-F

- | | | | |
|--|--|---|---|
| <p>R. F. By-pass No. 1</p> <ul style="list-style-type: none"> 1—2nd-detector—A. F. coupling condenser. 2—Quality condense.. 3—2nd-detector bias by-pass. 4—Phone condenser. | <p>R. F. By-pass No. 2</p> <ul style="list-style-type: none"> 5—A. F. bias by-pass. 6—R. F. grid filter condenser. 7—Control plate by-pass. 8—R. F.—I. F. bias by-pass. | <p>R. F. By-pass No. 3</p> <ul style="list-style-type: none"> 9—1st-detector plate filter condenser. 10—R. F.-1st-detector—I. F. screen by-pass. 11—1st-detector bias by-pass. 12—2nd-detector filter condenser. | <p>Tone-control Condenser</p> <ul style="list-style-type: none"> 13—Tone-control condenser. 14—Tone-control condenser. 15—2nd-detector screen by-pass. 16—2nd-detector screen by-pass. |
|--|--|---|---|

MODEL 87
1st Type
Below serial
2,525,871

ATWATER KENT MFG. CO.

BYPASS CONDENSERS: All bypass condensers located within the multiple unit are rated at 200 volts. The numbers shown within circles adjacent to the bypass condensers correspond with the numbers shown within the multiple bypass unit shown in connection with the schematic diagram. The multiple condenser unit is not marked with numbers. The condensers and numbers closest to the mounting holes represent the side of the condenser nearest the mounting holes.

FILTER CONDENSERS. The numbers in circles correspond with the numbers marked upon the filter unit. The following are the connections.

- Filter # 1 2.0 mfd connected between terminals (1) and (4)
- Filter # 2 2.3 mfd connected between terminals (2) and (4)
- Filter # 3 2.3 mfd connected between terminal (6) and can
- 1st A-F Bias .5 mfd connected between terminal (3) and center stud
- Hum .25 mfd connected between terminals (4) and (5)
- .1 mfd connected between center stud and can
- .1 mfd connected between terminal (2) and can

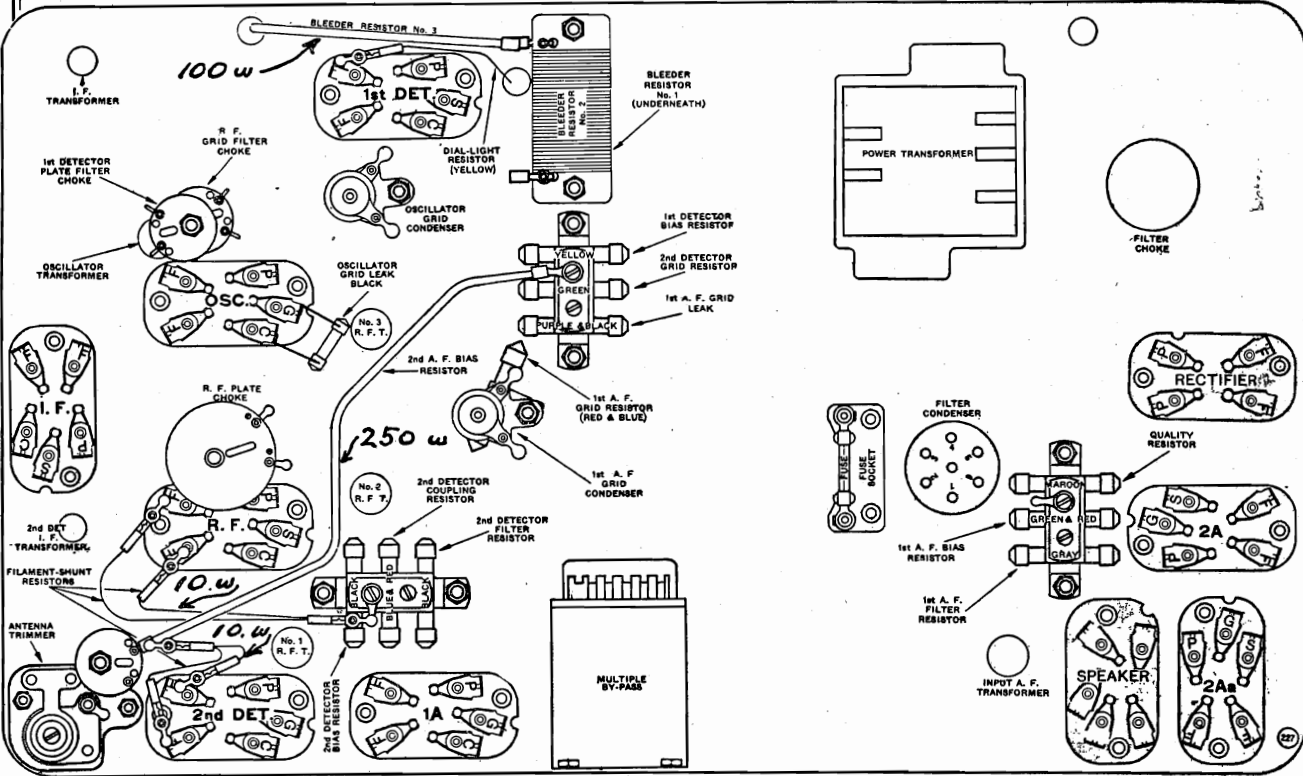

Condensers in Multiple By-pass Model 87

The internal connections of the multiple by-pass are shown

- 1—1st-detector plate filter condenser
- 2—1st-detector bias by-pass.
- 3—R. F.—I. F. bias by-pass.
- 4—2nd-detector grid-circuit by-pass.
- 5—2nd-detector—1st-A. F. coupling condenser.
- 6—Phone condenser
- 7—R. F. grid filter condenser.
- 8—Quality condenser.
- 9—2nd-detector bias by-pass.
- 10—2nd-detector filter condenser.
- 11—R. F.—1st-detector—I. F. screen by-pass.

ATWATER KENT MFG. CO.

MODEL 89, 89-F, 89-P 1st Type

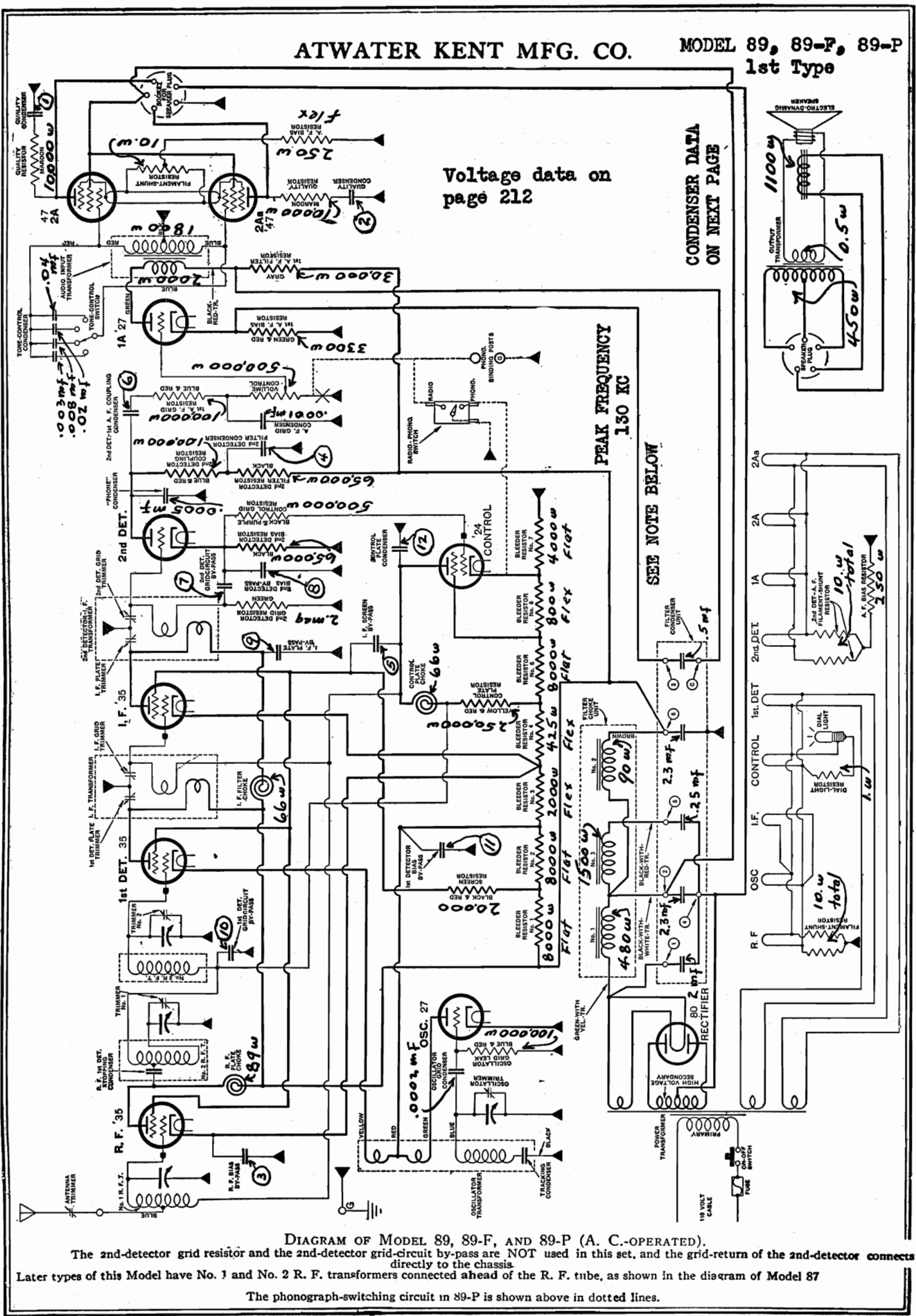

Voltage reference to page 2-5

MODEL 89, 89-F, 89-P

ATWATER KENT MFG. CO.

89 Below serial 6,755,181

89-F Below serial 1,585,395

89-P Below serial 1,935,904

FILTER CONDENSERS. The numerals adjacent to the filter condensers shown upon the wiring diagram correspond with the numbers stamped upon the condenser terminal block. The following are the connections:

- Filter # 1 2.0 mfd connected between terminals (1) and (4)
- Filter # 2 2.3 mfd connected between terminals (2) and (4)
- Filter # 3 2.3 mfd connected between terminal (6) and can
- Hum .25 mfd connected between terminals (5) and (4)
- A-F Filter .5 mfd connected between terminal (6) and center stud

BYPASS CONDENSERS. The numerals within circles adjacent to the bypass condensers shown upon the schematic wiring diagram correspond with the numbers shown upon the multi-section bypass units below.

Quality Condenser	1.	.03 mfd	450 volts	2.	.03 mfd	450 volts # 21450
RF Bypass # 1	6.	.05 mfd	400 volts	7.	.04 mfd	400 volts # 21440
	8.	.3 mfd	400 volts	*	See Note.	
RF Bypass # 2	3.	.1 mfd	400 volts	4.	.1 mfd	400 volts # 22050
	5.	.3 mfd	400 volts			
RF Bypass # 3	9.	.1 mfd	400 volts	10.	.02 mfd	400 volts # 21430
	11.	.06 mfd	400 volts	12.	.1 mfd	400 volts

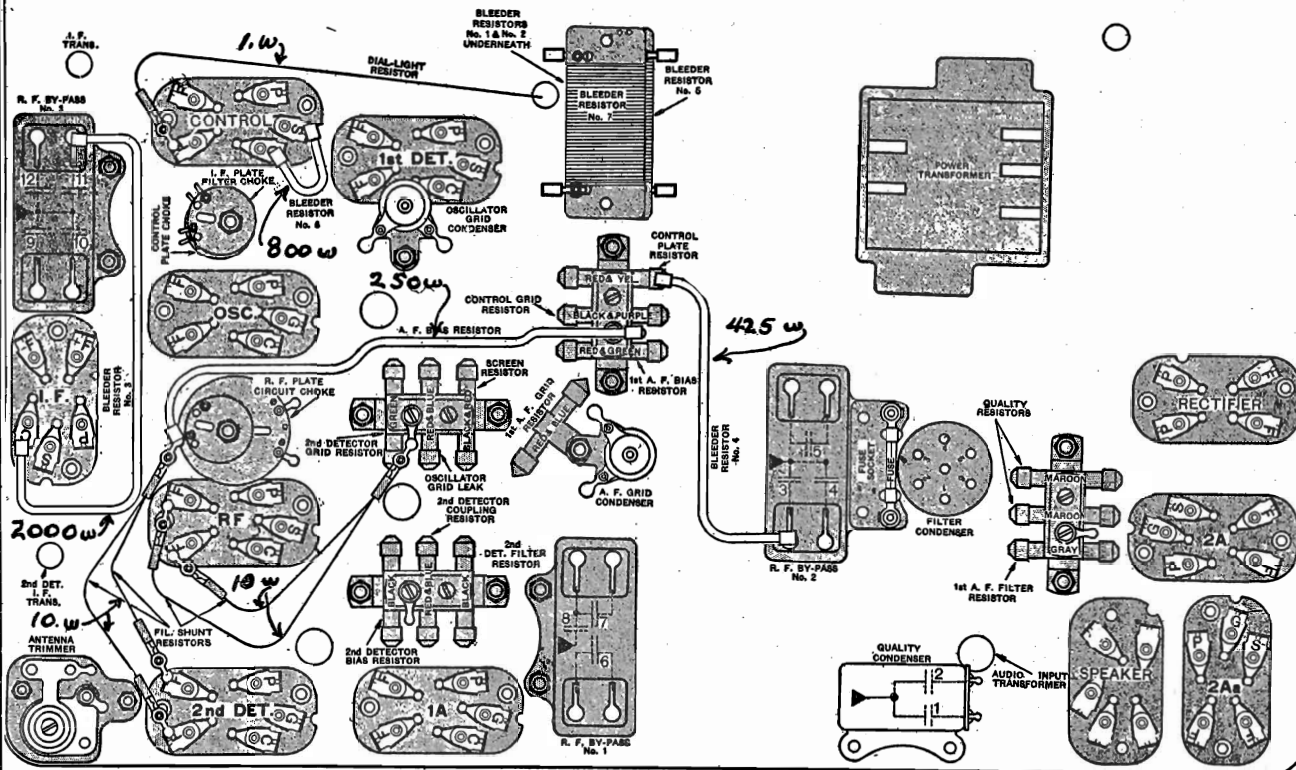

CHART OF MODEL 89, 89-F,

The 2nd-detector grid resistor is not used in late-type Model 89 89-F, 89-P.

- | | | | |
|--------------------------|--|----------------------------------|---------------------------------------|
| Quality Condenser | R. F. By-pass No. 1 | R. F. By-pass No. 2 | R. F. By-pass No. 3 |
| 1—Quality condenser. | 6—2nd-detector—1st-A. F. coupling condenser. | 3—R. F. bias-by-pass. | 9—I. F. plate by-pass. |
| 2—Quality condenser. | 7—2nd-detector grid-circuit by-pass. | 4—2nd-detector filter condenser. | 10—1st-detector grid-circuit by-pass. |
| | 8—2nd-detector bias by-pass. | 5—I. F. screen by-pass. | 11—1st-detector bias by-pass. |
| | (A small "phone" condenser, not shown, is connected internally to the lower-left terminal of by-pass No. 1.) | | 12—Control-plate condenser. |

PHONOGRAPH PICKUP

ATWATER KENT MFG. CO.

PHONOGRAPH PICKUP AND INDUCTION DISC MOTOR
(USED IN MODELS 75 AND 89-P)

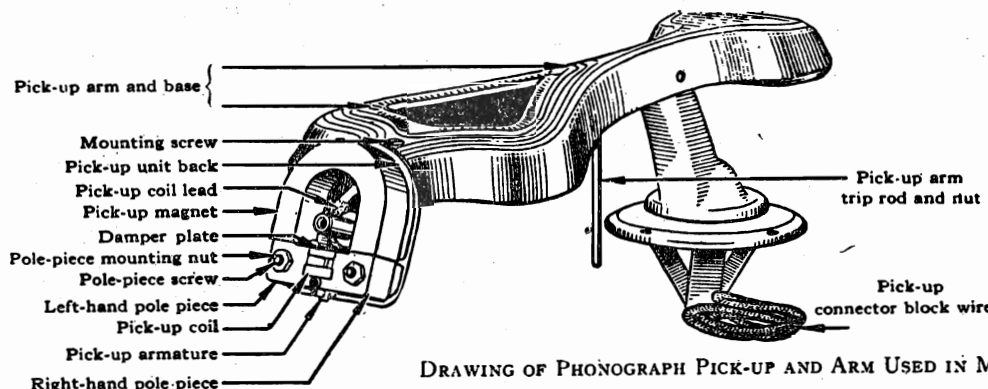

DRAWING OF PHONOGRAPH PICK-UP AND ARM USED IN MODEL 75.

PHONOGRAPH PICK-UP
ARMATURE ADJUSTMENT

The armature-pivot bearings consist of two small strips of rubber (armature spacing cushions) which space the armature from the bearing surfaces on each pole piece.

The top end of the armature fits in a slit in a flat rubber damper. The damper is fastened to a small brass plate that may be adjusted to the right or to the left, in order to center the armature in the magnet gap.

If the armature is off center, as indicated by erratic reproduction, loosen the two round-head screws that hold the damper plate, and move the plate slightly to the right or left to a point where the armature is centered. Tighten the two screws.

When the armature is correctly centered, it should take as much force to move the needle to the left as to the right.

If the rubber damper plate or armature spacing cushions are dried out, or lack life, replace them with new pieces of rubber, which may be secured from your distributor.

If the pick-up magnet must be removed from the pick-up **FIRST** place a steel or iron keeper (a large nail will do across the sides of the magnet poles, **THEN** remove the magnet.

Do **NOT** take off the keeper until **AFTER** the magnet is placed back on its pole pieces in the pick-up.

If the magnet is weak, have it re-magnetized, but be sure to place a keeper across the sides of the magnet poles before removing it from the magnetizer, and do not remove the keeper until after the magnet is placed back on its pole pieces in the pick-up.

CONTINUITY TESTS

Test across the two contacts on the neck of the molded pick-up back. The continuity reading should be nearly full. No reading indicates an open pick-up coil or leads.

Test from either contact on the pick-up to each pole piece, and to the armature. If there is any reading, it indicates that the pick-up coil or leads are grounded. This must be eliminated. Use two small pieces of thin cambric cloth to insulate the pick-up coil from the pole pieces.

AUTOMATIC ELECTRIC
SWITCH and FRICTION BRAKE

ADJUSTMENTS

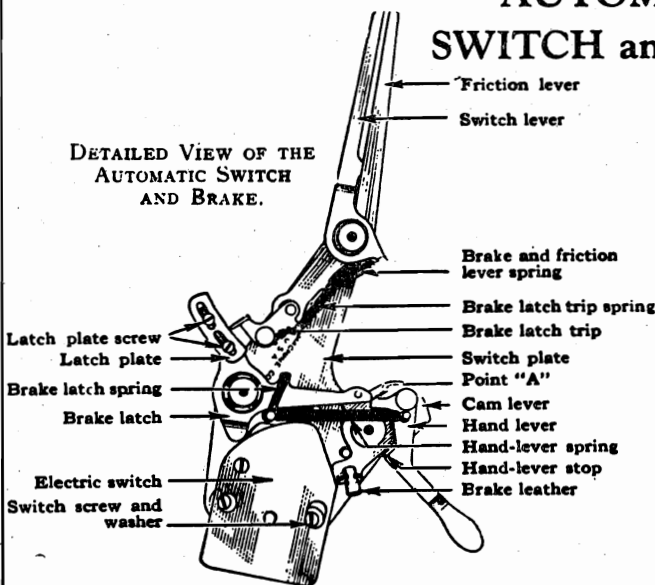

DETAILED VIEW OF THE
AUTOMATIC SWITCH
AND BRAKE.

(1) If the latch does not trip, or trips before completion of a record, bend the hand-lever stop slightly to the right or left, as necessary.

(2) If the latch trip does not engage correctly with the latch-plate, loosen the two latch-plate screws and shift the plate one way or the other, as necessary. Re-tighten the screws. Remove any burrs from the teeth of the latch plate with fine emery paper.

(3) If the electric switch does not make and break contact when the hand-lever is turned on and off, it may be necessary to bend the long contact spring, or loosen the two switch screws and move the switch until the correct position is found. In the off position, there should be at least $\frac{1}{16}$ " gap between the contact points.

PHONOGRAPH PICKUP

ATWATER KENT MFG. CO.

PHONOGRAPH PICKUP AND INDUCTION DISC MOTOR
(USED IN MODELS 75 AND 89-P)

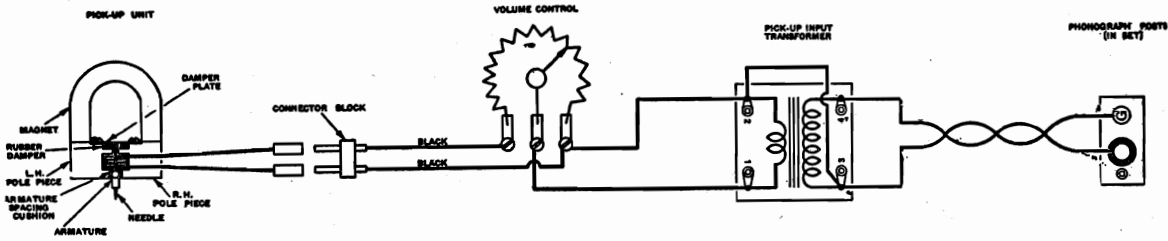

ELECTRICAL CONNECTIONS OF PICK-UP, VOLUME CONTROL AND INPUT TRANSFORMER.

INDUCTION DISC
PHONOGRAPH MOTOR

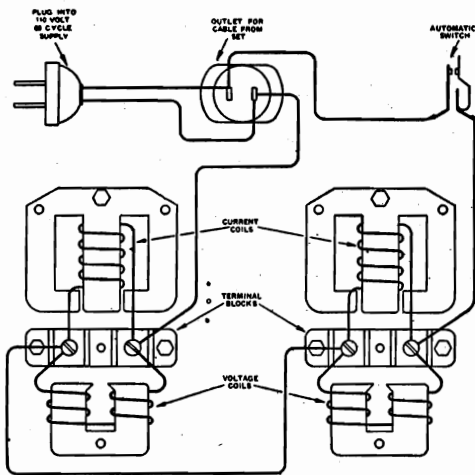

ELECTRICAL CONNECTIONS OF THE INDUCTION-DISC PHONOGRAPH MOTOR.

The induction-disc phonograph motor has two sets of field coils or "inductors." Each inductor has three coils and five "poles." A magnetic field is produced between the poles by the alternating current flowing through the three coils.

The edge of a non-magnetic rotor disc fits in the narrow gap between the poles on each inductor. The magnetic field between the poles causes the disc to rotate.

The rotor disc itself has no coils, and there are no electrical connections to it.

The speed of the rotor disc is controlled by a governor and a regulating screw device. The correct speed is 78 revolutions per minute (with pick-up on record). The speed may be determined by counting the number of revolutions made by the turntable in one minute. It is preferable,

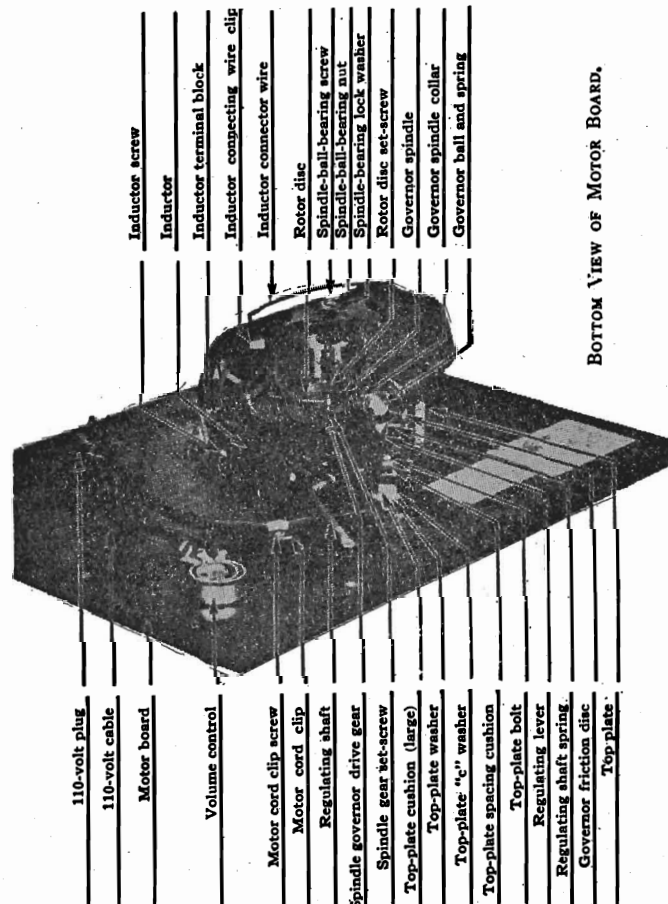

BOTTOM VIEW OF MOTOR BOARD.

however, to regulate the speed with the aid of a stroboscope disc, which may be purchased from your distributor. Simple instructions for the use of this inexpensive device are printed on the back of the stroboscope disc. The speed should be checked at least twice a year.

The motor and governor bearings and gears must be kept well greased at all times. See chart on bottom of motor board.

When an induction-disc motor requires repair, it is advisable to tear it down completely, replace the defective parts, clean and grease all parts, and reassemble correctly.

MODEL 4 Tube Pentode '31
 MODEL 5 Tube Pentode '31

AUDIOLA RADIO CO.

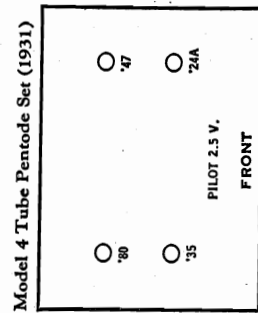
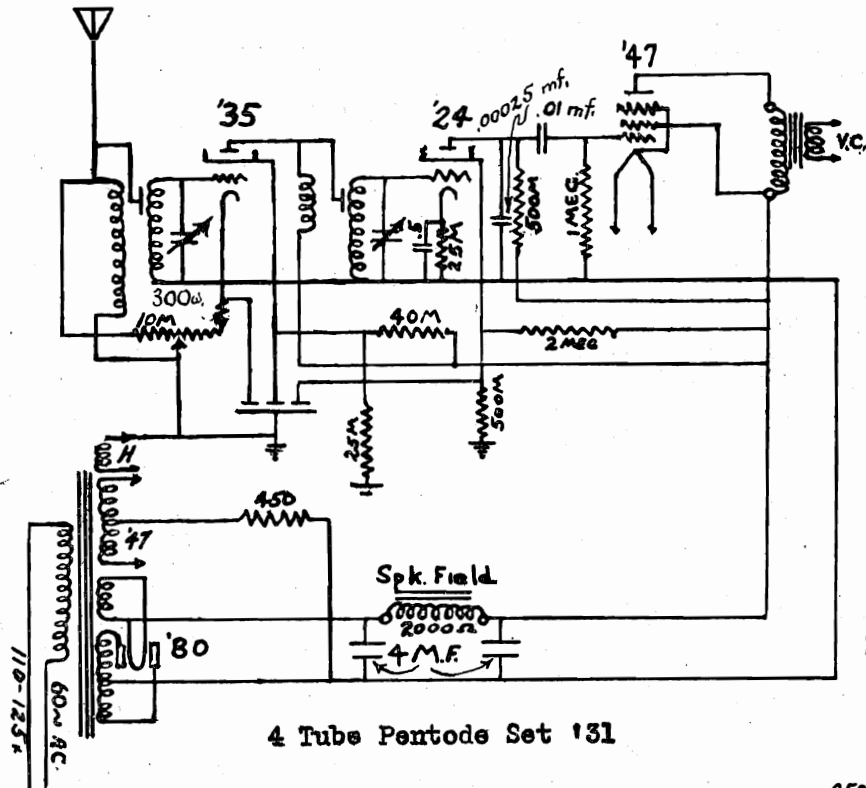

#62231
 4T-31-RF

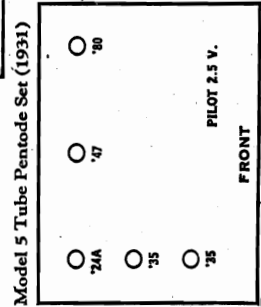
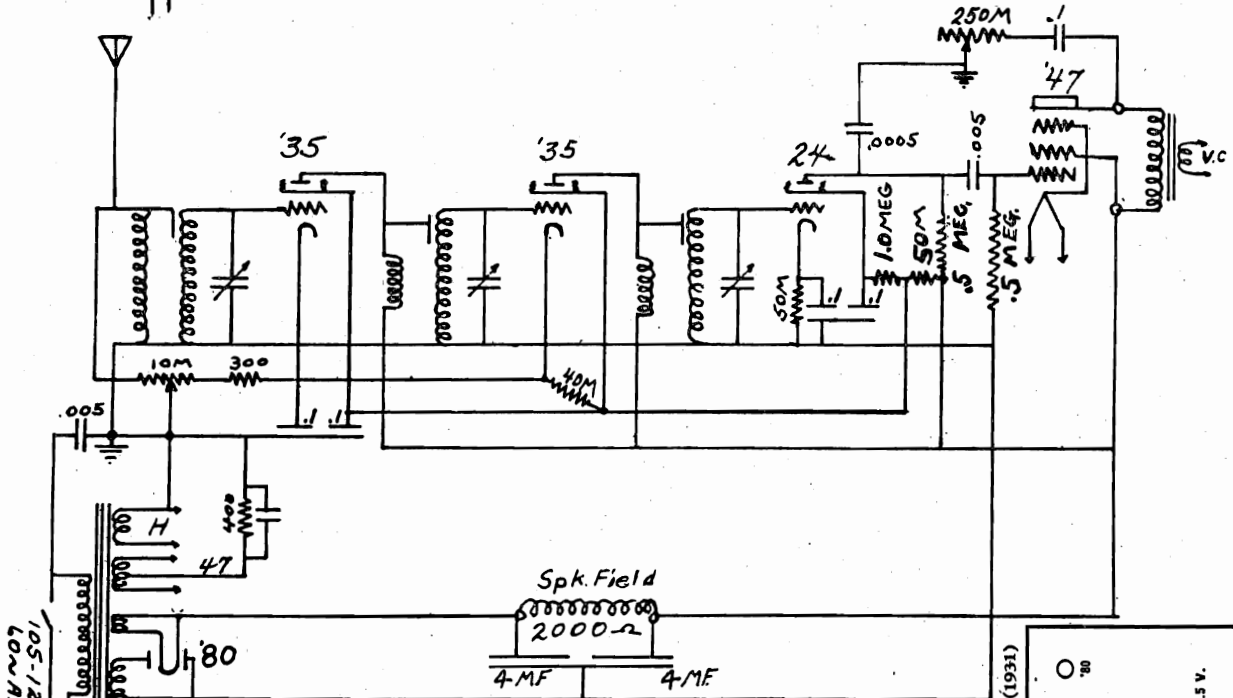

1375

AUDIOLA RADIO CO.

MODEL '31 Super
Service Notes

SERVICE NOTES

A There are ten tuned circuits, all of which must be in accurate adjustment in order to allow this receiver to operate at its maximum efficiency. These adjustments are made by means of eleven trimming condensers which are carefully set and locked at the factory and should need no further attention provided they are not tampered with. These condensers are all of the compression type and are adjusted by the rotation of the long nut and locked by means of a hardened steel set screw. The service man should delicately attempt rotation of these nuts with a special nut wrench to determine if they are loose, and if all are tight and locked they should never be touched unless it is definitely assured that the set is out of alignment after every other service possibility has been exhausted.

A piece of thin fiber tubing about 7" long and with $\frac{1}{4}$ " bore which can be supplied by us for this purpose may form the nut wrench. The locking screw driver should be long and thin enough to slip down thru the fiber tubing and lock the set screw, while the nut is held from turning by the tubing wrench.

By inspection of the service wiring diagram it will be noted that there are six capacity adjustments, one on each primary and one on each secondary of the three intermediate-frequency transformers. These condensers resonate the tuned circuits of the intermediate-frequency amplifier to exactly 175 KC. There are also four trimming condensers, one on each section of the four gang variable condenser. The three trimming condensers associated with the pre-selector, R.F. and detector stages balance these three stages to resonance while the fourth trimming condenser, which is on the oscillator section of the four gang variable condenser, forms part of the network which adjusts the oscillator to its constant frequency difference of 175 KC. There is also another oscillator trimming condenser located next to the last section of the four gang tuning condenser and adjacent to the first detector tube. In some chassis this is reached thru a hole in the top of the condenser gang near the front and in others thru a hole in the chassis in front of the dial. This condenser is called the 600 KC oscillator trimming condenser, while the one on the oscillator section of the tuning condenser gang is the 1400 KC oscillator trimming condenser.

In order to adjust all of these trimming condensers properly it is necessary that an R. F. oscillator giving a modulated signal at exactly 1400 KC and 600 KC, and also at 175 KC be secured. An output measuring instrument is also necessary. The General Radio Company type 360-A or Radio Products Co., Dayton, Ohio, HR 180 test oscillators are suitable for this purpose.

The output meter leads should be connected across the cone coil connections of the loud speaker. The cone coil may remain connected or be disconnected, satisfactory results being obtained in either case, although the cone is left connected an audible check on the instrument readings is obtained.

The receiver must be balanced from back to front or left to right, that is, the last I. F. transformer is adjusted first, then the next to last I. F. transformer, etc., working backwards thru the first detector, oscillator, R. F. and pre-selector.

The following procedure should be followed:

3. Adjust the secondary and then the primary trimming condenser of the last I. F. transformer until a maximum reading is obtained on the output meter. These two circuits must be accurately peaked to 175 KC and will be found quite sharp.

4. After adjusting the third I. F. transformer shift the coupling lead to the control grid connection of the first I. F. tube and place the lead at a greater distance from the oscillator. Be sure the shields are on all tubes except that to which the coupling lead is connected. Turn the volume control up slightly and in exactly the same manner adjust the secondary and primary of the second I. F. transformer until a maximum indication is obtained. The output must be kept low enough to give a sharp peak.

5. Clip the coupling lead on to the control grid cap of the first detector tube, replacing all other shields and proceed to peak the secondary and primary of the first I. F. transformer. If the set oscillates it is due to the coupling lead being connected to the grid of the first detector and the volume control should be slightly reduced to prevent oscillation. Now with a given indication on the output meter proceed to "touch up" all of the adjusted trimming condensers to take advantage of any slight increase in reading that might be obtained by more careful peaking, and after they are all correctly balanced lock them by holding with the nut wrench and tightening the set screw with a long screw driver. The insertion of the metallic screw driver will affect the reading of the output meter but it should return to normal when the screw driver is removed. Note carefully that the locking does not throw the stage out of alignment. It may be easier for the service man who is not familiar with this operation to slightly reduce the capacity of the trimming condenser and lock the screw down fairly tight and then after removing the screw driver, slowly bring the unit up to its peak reading. This may be found difficult at first but with a little experience the I. F. stage can be rapidly balanced.

6. Now set the test oscillator in operation at exactly 1400 KC, place the set in normal operation and replace the oscillator tube and all shields. Make sure the receiver is properly grounded and has an average antenna. Set the local-distance switch in the distance position thereby connecting the antenna. Couple the test oscillator to the antenna by means of its coupling lead. Locate the 600 KC oscillator trimming condenser and turn it nearly all the way in, about one-half revolution from full in.

7. Tune in the 1400 KC signal, adjusting the volume control to give a good indication on the output meter, then adjust the tuning knob until the scale reads 1400 KC. Now adjust the 1400 KC oscillator trimming condenser (on the oscillator section of the four gang condenser), the first detector, R. F. and pre-selector circuit trimming condensers in the order given until maximum output is obtained. The oscillator section of the gang condenser is the second section from the dial. When the set is not in a cabinet the location of a pointer for dial calibration is determined at maximum capacity of the condensers by a line provided at the low frequency end of the tuning scale.

8. Tune the test oscillator to exactly 600 KC. Tune in the signal on the set and adjust the 600 KC oscillator trimming condenser for maximum output on the output meter while revolving the gang condenser back and forth, by rotating the tuning knob.

9. Set the test oscillator frequency to 1400 KC and set the selector scale at exactly 1400 KC. Adjust the four trimming condensers as in No. 7 in the order given until maximum output is obtained.

10. Place the test oscillator again in operation at 600 KC and tune in the signal and if adjustments have been properly made the signal will be received at maximum output when the scale reads exactly 600 KC. If not the operations described above must be repeated.

11. Now lock all trimmers as described in the instructions for locking the intermediate frequency trimmers (paragraph 5) while carefully watching the output meter to make sure that the locking action does not throw the stage out of alignment.

AUTOMATIC RADIO MFG. CO

MODEL 44
 MODEL V-45, V-46
 MODEL C-45
 MODEL P-46

MODELS NO. - 44, V45, V46, C 45, P46.

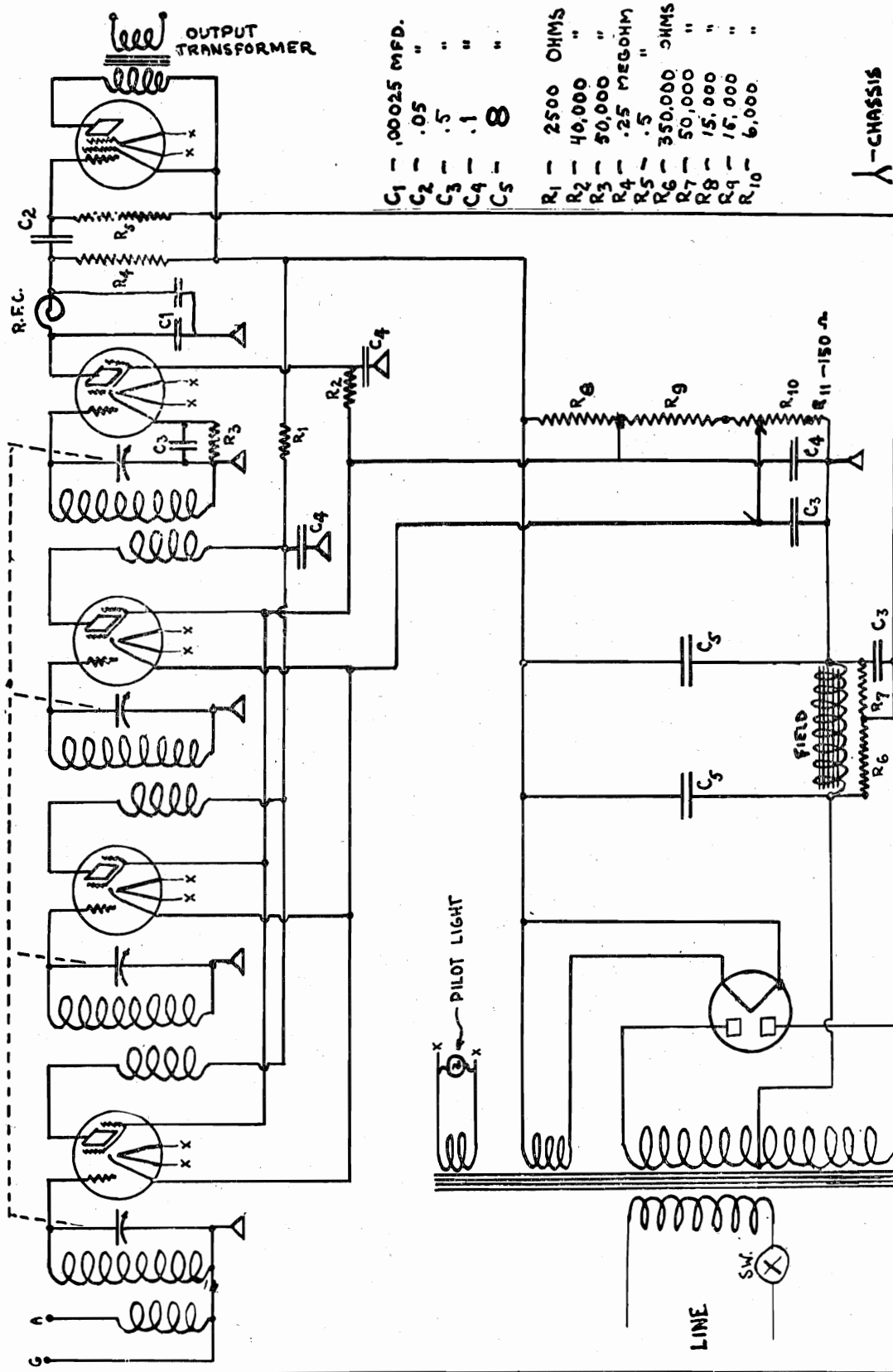

- C1 - .00025 MFD.
- C2 - .05 " "
- C3 - .5 " "
- C4 - .1 " "
- C5 - 8 " "
- R1 - 2500 OHMS
- R2 - 40,000 "
- R3 - 50,000 "
- R4 - .25 MEGOHM
- R5 - .5 " "
- R6 - 350,000 OHMS
- R7 - 50,000 "
- R8 - 15,000 "
- R9 - 15,000 "
- R10 - 6,000 "

⏏ - CHASSIS

AUTOMATIC RADIO CO. INC.
 BOSTON, MASS.

MODEL P-35, 34

AUTOMATIC RADIO MFG. CO.

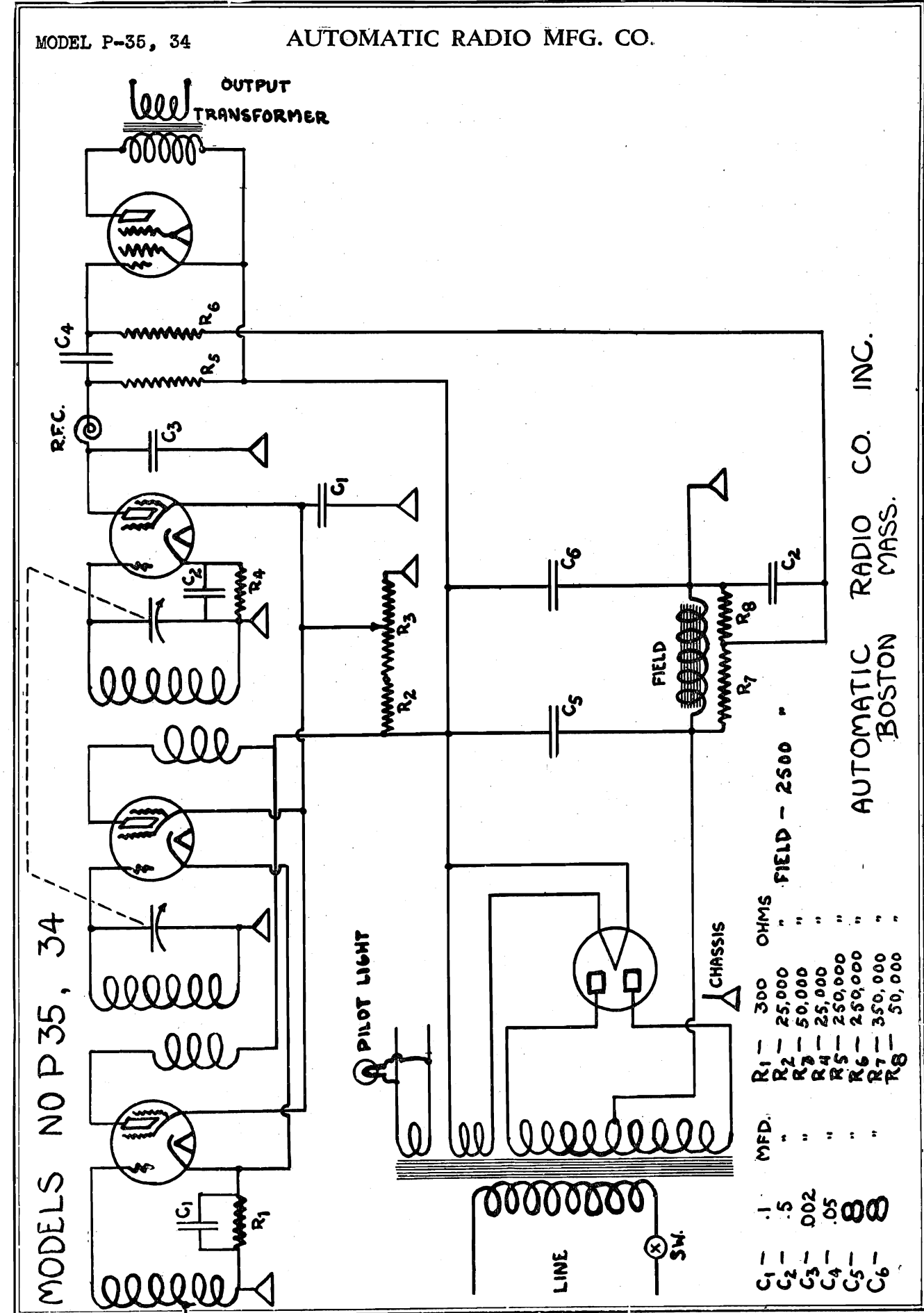

MODELS NO P 35, 34

C1	.1	MFD.	R1	300	OHMS
C2	.5	"	R2	25,000	"
C3	.002	"	R3	50,000	"
C4	.05	"	R4	25,000	"
C5	50	"	R5	250,000	"
C6	50	"	R6	250,000	"
			R7	350,000	"
			R8	50,000	"

AUTOMATIC RADIO CO. INC.
BOSTON MASS.

BREMER-TULLY MFG. CO

MODEL B-T 6
MODEL 8-12
Counterphase

Models 8-12, 8-16

1 RF	2 RF	3 RF	DET	3 RF
01A	01A	01A	01A	12A OR 71A
				2 AF
				01A
				1 AF
				01A
FRONT				

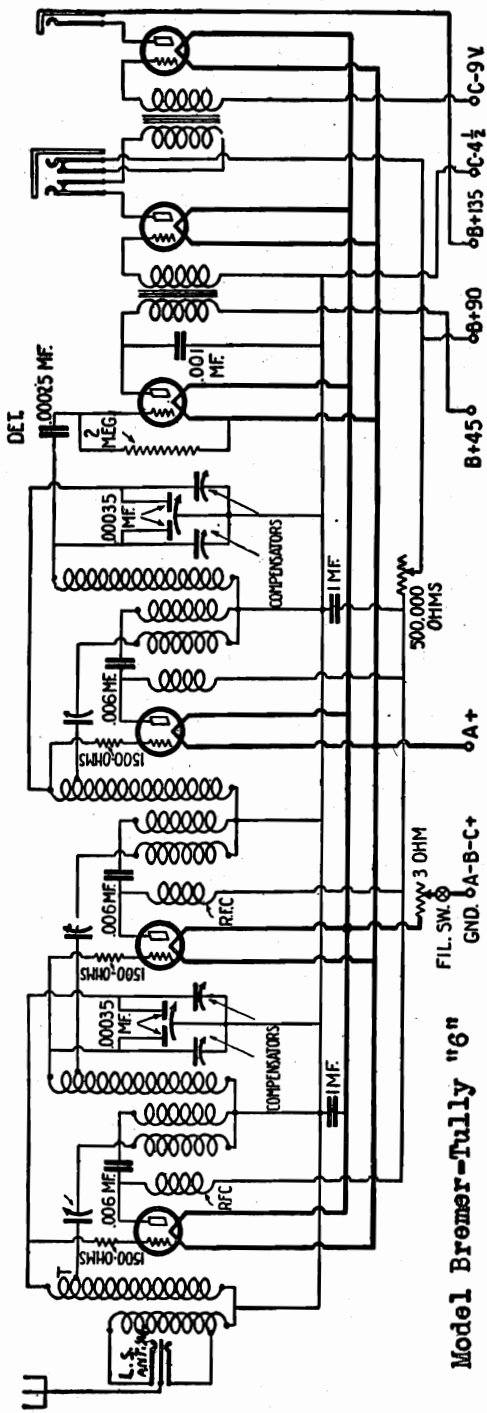

Model Bremer-Tully "6"

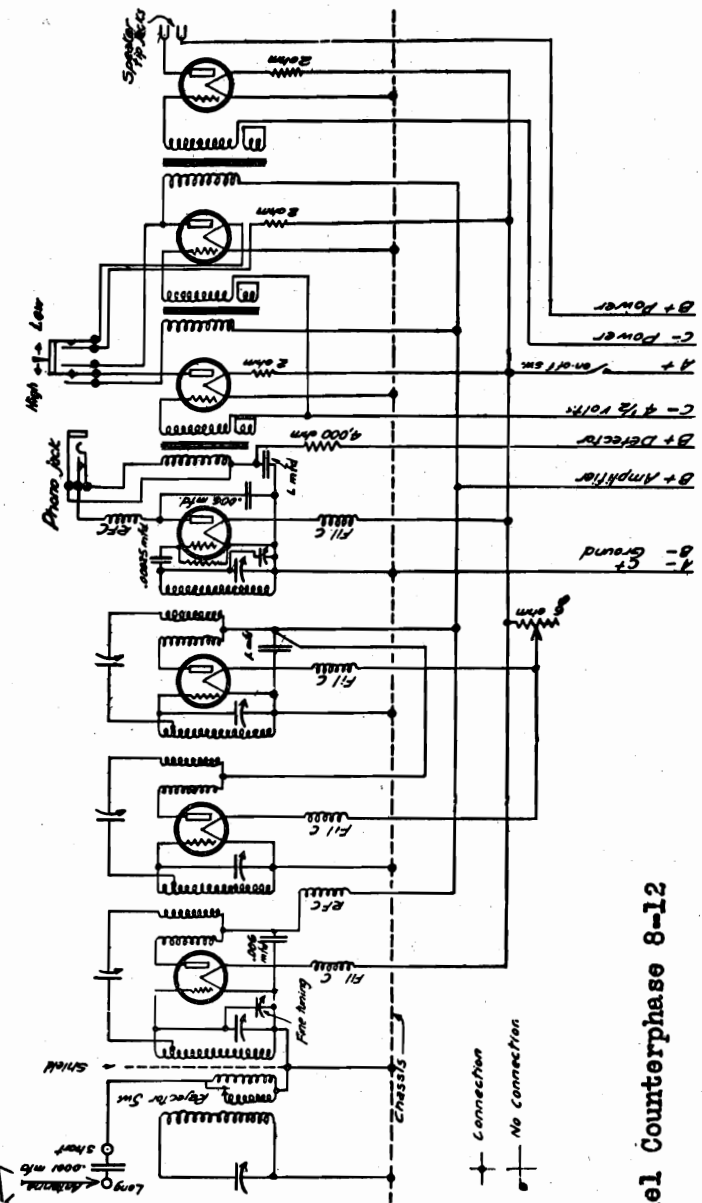

Model Counterphase 8-12

BRUNSWICK RADIO CORPORATION

MODEL 10
Schematic and
Voltage

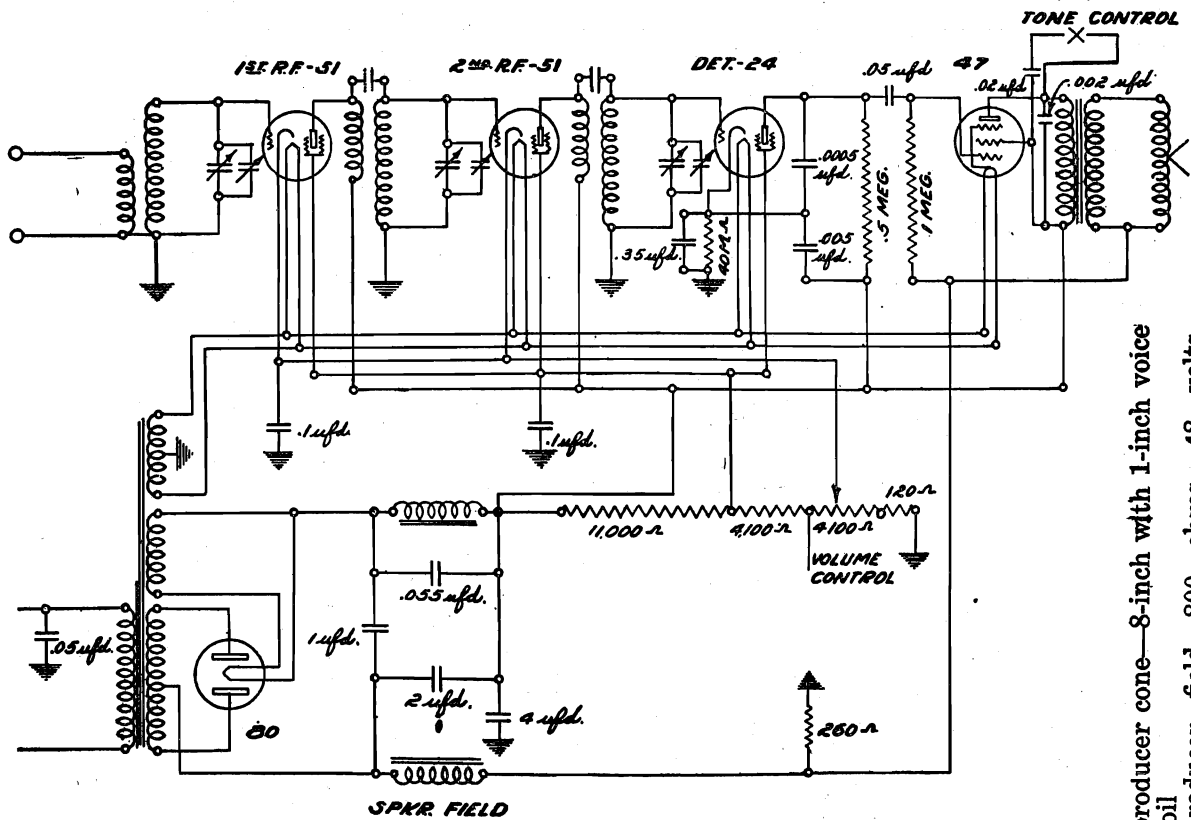

Reproducer cone—8-inch with 1-inch voice coil
Reproducer field—800 ohms, 48 volts, 60MA

VOLTAGE ANALYSIS

No.	Stage	Type Tube	Fil. Volts	Plate Volts	Cont. Grid Volts	Cath. Volts	S. G. Volts	Ip. Normal
1	1st R. F.	C. L. 51	2.1	225	2.1	2	75	5
2	2nd R. F.	C. L. 51	2.1	230	2.2	2	75	4.5
3	Det.	C. L. 24	2.1	160*	7	7.5	75	.02
4	Output	C. L. 47	2.1	215	5*	0	225	26.5
5	Rect.	C. L. 80	4.8	280				†30

*Reading dependent upon resistance of meter.

†Reading taken for one anode only: 60 milliamperes would be about correct.

Volume control position full. Line voltage 115—60 cycle.

RESISTANCE TABLE

(Using 10-volt range meter 1,000 ohms per volt and 6-volt battery)

Item	Color Code*	From	To	Reading	Your Reading	Resistance in Ohms
Det. Cath. Resistor	Yel., Blk., Or.	Det. Cath.	Gnd.	1.3		40,000
Pent. Grid Resistor	Br. Blk. Green	Pent Grid	Spkr. Field	Slight Deflection		1,000,000
Wire Wound	Black	Voice Coil. Black	Gnd.	5.9		260
Voltage Divider. Short End	Black	Volume Cont. Green Lead	S. G. Ckt.	4.2		4,100
Voltage Divider. Long End	Black	Plate	S. G. Ckt.	3.		11,000
Det. Plate Resistor	Gr., Blk., Yellow	Det. Plate	Pent. Space Chg. Grid.	.1		500,000
Vol. Control "on"		Gnd.	R. F. Cathode	4.2		4,100

Color code: read body color first, tip second and dot last.

BRUNSWICK RADIO CORPORATION

MODEL 11, 12, 16 and 33 AC

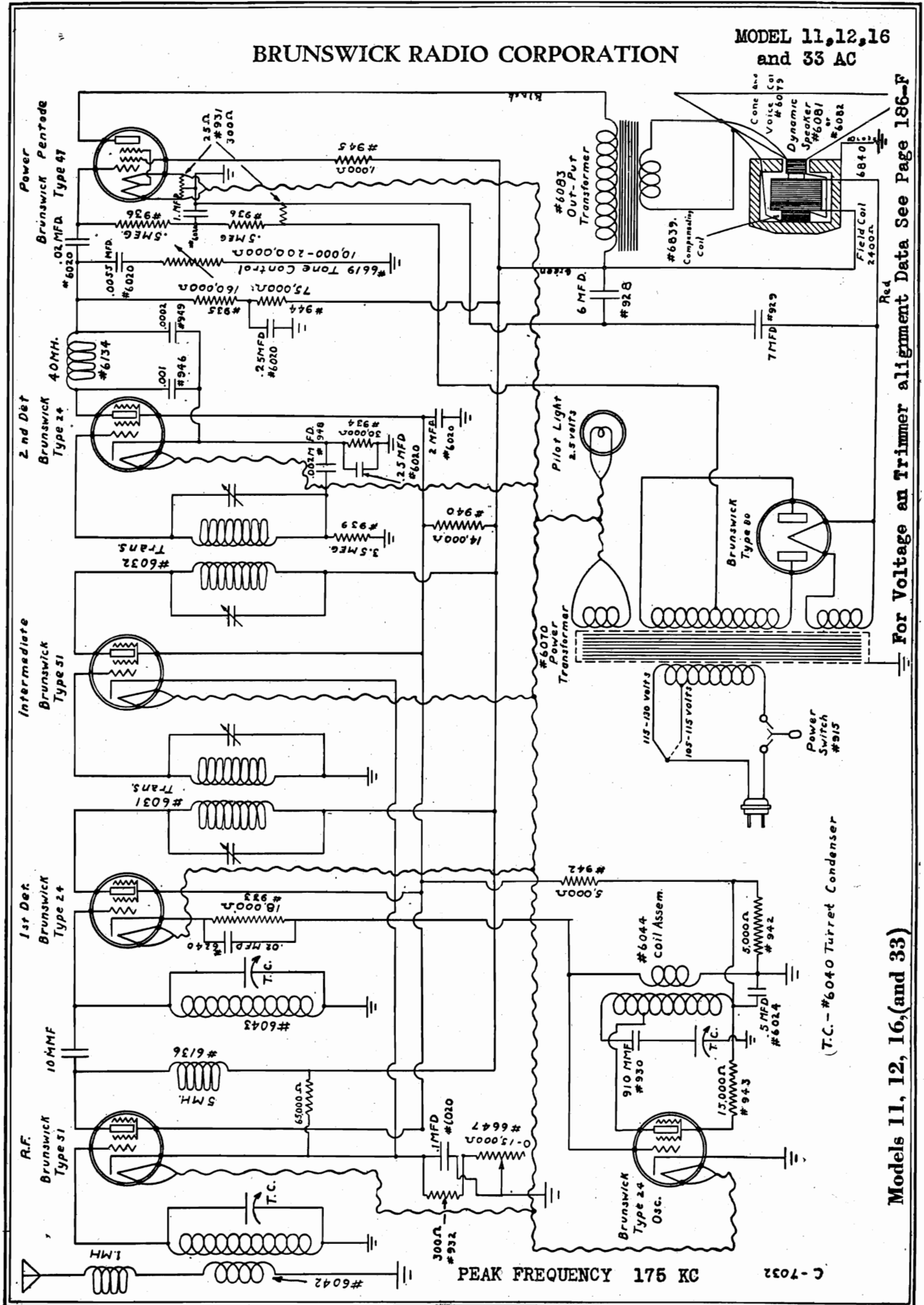

PEAK FREQUENCY 175 KC

C-7032

Models 11, 12, 16, (and 33)

For Voltage an Trimmer alignment Data See Page 186-F

(T.C. - #6040 Turret Condenser)

MODEL 11,12,16
and 33
Service Notes

BRUNSWICK RADIO CORPORATION

MODELS 11,12,&16.

SOCKET ANALYSIS—120 VOLT LINE

Volume Control Set at Maximum—Short Antenna to Ground

Position	Type Tube	Heater Voltage	Control Grid Voltage	Plate Voltage	Plate Current	Screen Grid Voltage
1st R.F.	—51	2.25	3.5	230	3.4 MA	70
1st Det.	—24	2.25	5.8	220	.4 MA	62
I.F.	—51	2.25	3.8	220	9 MA	60
2nd Det.	—24	2.25	.2	115*	.3 MA	60
Osc.	—24	2.25	0	35	1.2 MA	22
Power Output	—47	2.25	1	220	33 MA	220
Rec. Tube	—80	4.7		(530) (530)	(26 MA) (26 MA)	

* Readings will vary according to resistance of meter.
Tubes used in this test are average tubes.

METHOD OF ALIGNING R.F. CIRCUITS

In the event the antenna and first detector tuned circuits are out of alignment, they may be adjusted with the aid of a weak high frequency (1300 to 1500 K. C.) signal—produced by a distant station or a local test oscillator. Tune this signal in very carefully for maximum volume, or better still, if one is available, for maximum deflection on an output meter. Adjust the antenna tuned circuit adjustment screw (located near the type 47 tube on the top plate of the turret condenser) for maximum volume or for maximum deflection on an output meter. Then, without changing the position of the tuning knob, adjust the first detector adjustment screw—located adjacent to the A. C. switch—for maximum volume or maximum deflection on an output meter. Before tightening the lock unit on each adjustment screw, go over the adjustments a second time to secure the greatest possible accuracy. A drop of ambroid glue or collodian should be placed on each adjustment screw after the lock nut has been tightened to prevent handling and speaker vibrations from changing the adjustment.

In most cases it will be unnecessary to touch the oscillator adjustment screw (located between the antenna and first detector adjustment screws.) If this adjustment is necessary it is recommended that the intermediate frequency transformer circuits be tuned first (see following paragraph). Then tune oscillator circuit, employing same method as explained above for antenna tuned circuit and first detector circuit. In the event any circuit does not tune properly, check the circuit thoroughly for open and short circuits. If the trouble cannot be located, the coil should be replaced with a new one.

METHOD OF ALIGNING I.F. TRANSFORMERS

In the event the receiver is still insensitive and lacks proper selectivity after making the foregoing adjustments, the intermediate frequency transformers should be adjusted by one of the following methods:

1. Tuning Intermediate Transformers with 175 K.C. Oscillator

By far the best method of aligning the tuned circuits in the intermediate frequency transformers is to employ a 175 K.C. oscillator and output meter. In making this test, remove the oscillator tube and connect the output of the oscillator to the grid cap of the first detector. Usually it will not be necessary to remove the grid cap from the tube, this depending on the strength of the oscillator and the amount the I.F. transformers are out of line. Connect the output meter across the primary of the output transformer located on the speaker (terminals 3 and 7 counting from left to right). The four I.F. adjustment screws on the I.F. transformers, located inside the chassis, should be adjusted with a non-metallic screw driver for maximum deflection on the output meter. Go over all four adjustments a second time to secure maximum accuracy.

2. Tuning Intermediate Transformers without 175 K.C. Oscillator

In the event a 175 K.C. oscillator is not available a fairly close adjustment may be made by tuning in a faint broadcast signal, and with the volume control turned on full, adjust the transformers for maximum volume with a non-metallic screw driver. After adjusting the I.F. transformers, the R.F. circuits should be realigned as explained before.

MODEL 14,21,31 DC
Socket and Voltage BRUNSWICK RADIO CORPORATION
Data and Notes

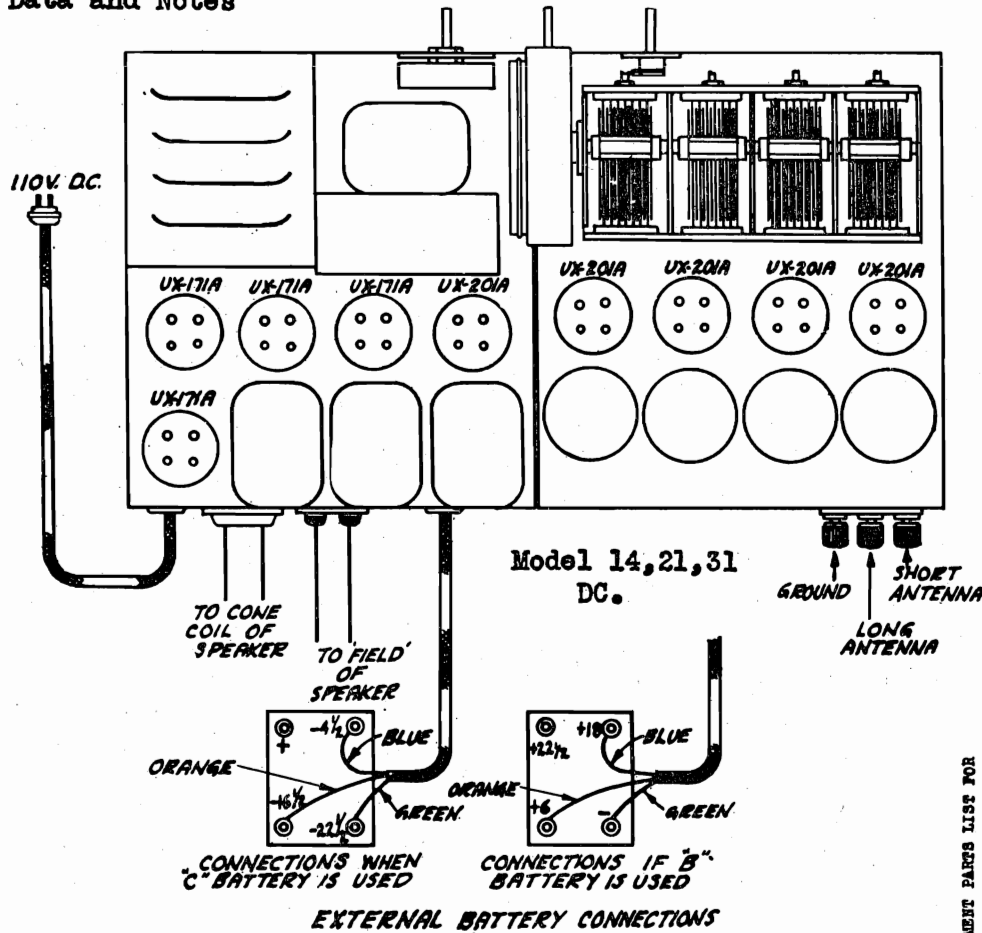

- REPLACEMENT PARTS LIST FOR**
- Choke Mounting Brackets
 - 5" Bolt for Mtg. Resistor
 - R.F. Socket Strip
 - 6 Volt Pilot Light
 - D.C. Chassis Complete - Models 14 and 21
 - D.C. Chassis Complete - Model 31
 - D.C. Phono Motor (Gordon Type)
 - Audio Chassis for D.C. Models 14 and 21
 - R.F. Chassis for D.C. Models 14, 21, and 31
 - Audio Chassis for D.C. Model 31

- REPLACEMENT PARTS LIST FOR**
- D.C. MODELS 14, 21, & 31
- Resistance Unit: 200 ohms (Large Brown)
 - Resistance Unit: 220 ohms (Large Brown)
 - Resistance Unit: 500 ohms (Large Brown)
 - Resistance Unit: 120 ohms (Purple)
 - Resistance Unit: 200 ohms (Grey)
 - Resistance Unit: 35,000 ohms (Yellow)
 - Resistance Unit: 40 ohms (Wire Wound)
 - Double Filament By-Pass Cond. - 5 mfd. (W-6428)
 - Series Ground Cond. - .002 mfd.
 - Insulating Bushings for Vol. Cont.
 - Insulating Bushings for Gnd. Binding Post.
 - Heavy Duty Filament Choke

- PART No.**
- I-1301
 - I-1302
 - I-1303
 - I-1304
 - I-1305
 - I-675
 - I-1307
 - I-1308
 - I-1309
 - I-1310
 - I-1311
 - I-1312
 - I-1313

VOLTAGE READINGS AT SOCKETS

Socket	Tube	Type	Filament	Grid	Plate
#1	1st R.F.	UX-201-A	5.5	-9	80
#2	2nd R.F.	" "	5.	-9	80
#3	3rd R.F.	" "	5.25	-5	80
#4	Detector	" "	5.25	0	32
#5	1st Audio.	" "	5.75	-9	88
#6	Power Stage	UX-171-A	5.	-24	96
#7	" "	" "	5.	-15	88
#8	" "	" "	4.3	-15	92
#9	" "	" "	4.3	-22½	96

These readings will hold within 10% when taken with any reliable make of set analyzer with the tube in the socket of the set analyzer, the line voltage at 120 volts, and the volume control on maximum. Filament voltage will vary with different tubes because their filament resistance varies.

METHOD OF ADJUSTING NEUTRALIZING CONDENSERS.

In the event the receiver oscillates at any or all parts of the tuning range, the ground and antenna should be inspected to be sure there is not a poor connection at some point. If the oscillation still persists, try changing the tubes around, and if this does not eliminate the trouble, the receiver should be neutralized by the following method:

Select a good UX-201-A tube of the same make that is to be used in the receiver and cut off one filament prong close to the base. Because the filaments of all tubes are connected in series, it will be necessary to connect a 1.25 ohm resistor across the filament contacts of the socket in which the dummy tube is to be used. (The filament of another tube may be used for this purpose.) Tune the receiver to a powerful local station broadcasting on a frequency of between 1000 and 1500 kilocycles, and adjust volume control and antenna trimmer condenser for maximum volume. Insert the dummy tube in the first socket and connect the resistor or tube filament across the filament circuit - the first neutralizing condenser should now be adjusted until no sound, or the minimum sound, is heard in the reproducer. Adjust the other two stages in the same manner and the receiver is neutralized.

In the event the receiver cannot be neutralized the R.F. by-pass condensers should be tested for open circuits and a different dummy tube should be tried.

MODEL 14,21,31 DC

Schematic

BRUNSWICK RADIO CORPORATION

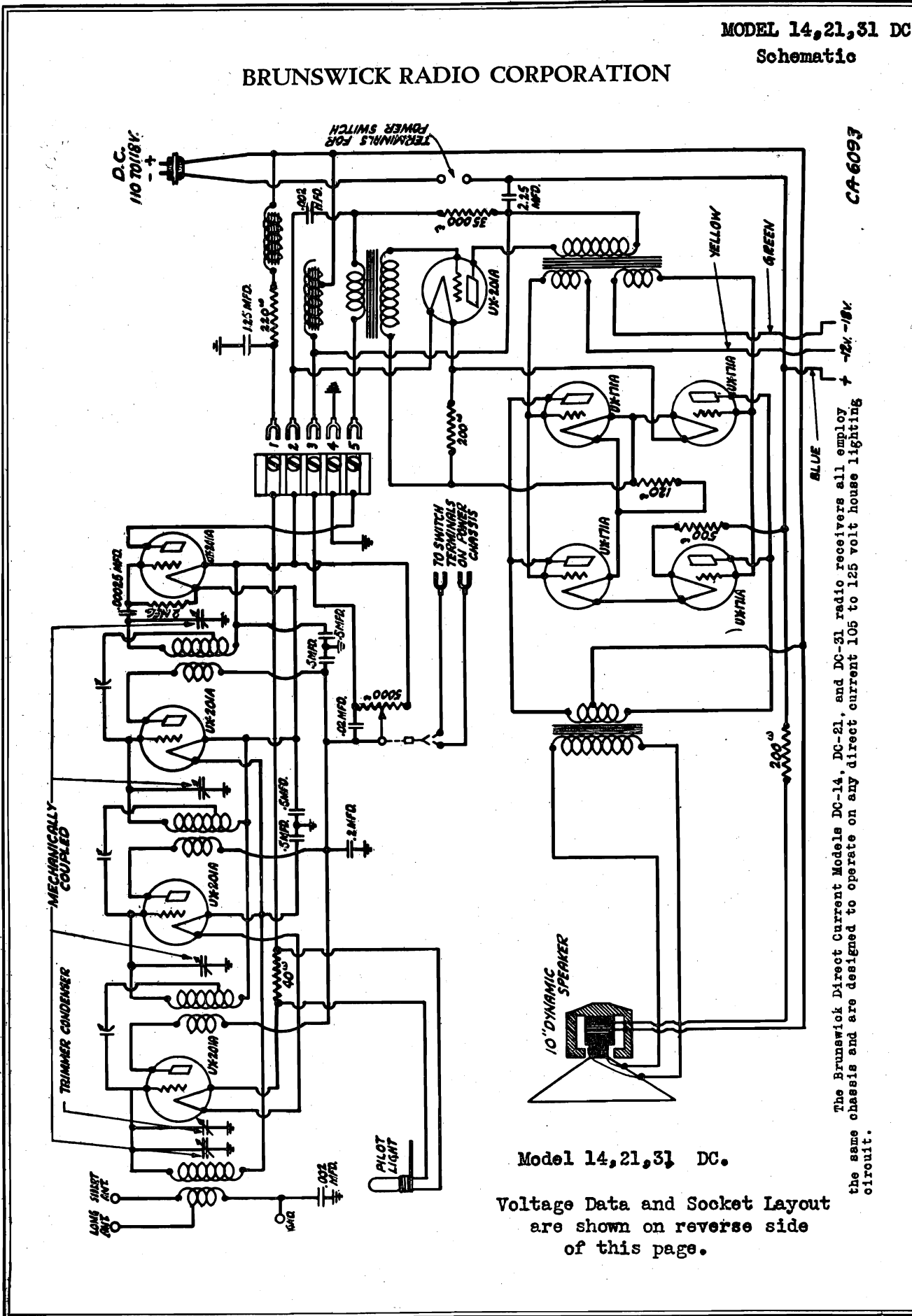

CA-6093

The Brunswick Direct Current Models DC-14, DC-21, and DC-31 radio receivers all employ the same chassis and are designed to operate on any direct current 105 to 125 volt house lighting circuit.

Model 14,21,31 DC.

Voltage Data and Socket Layout are shown on reverse side of this page.

MODEL 15-B
Schematic

BRUNSWICK RADIO CORP.

Inductor
Dynamic

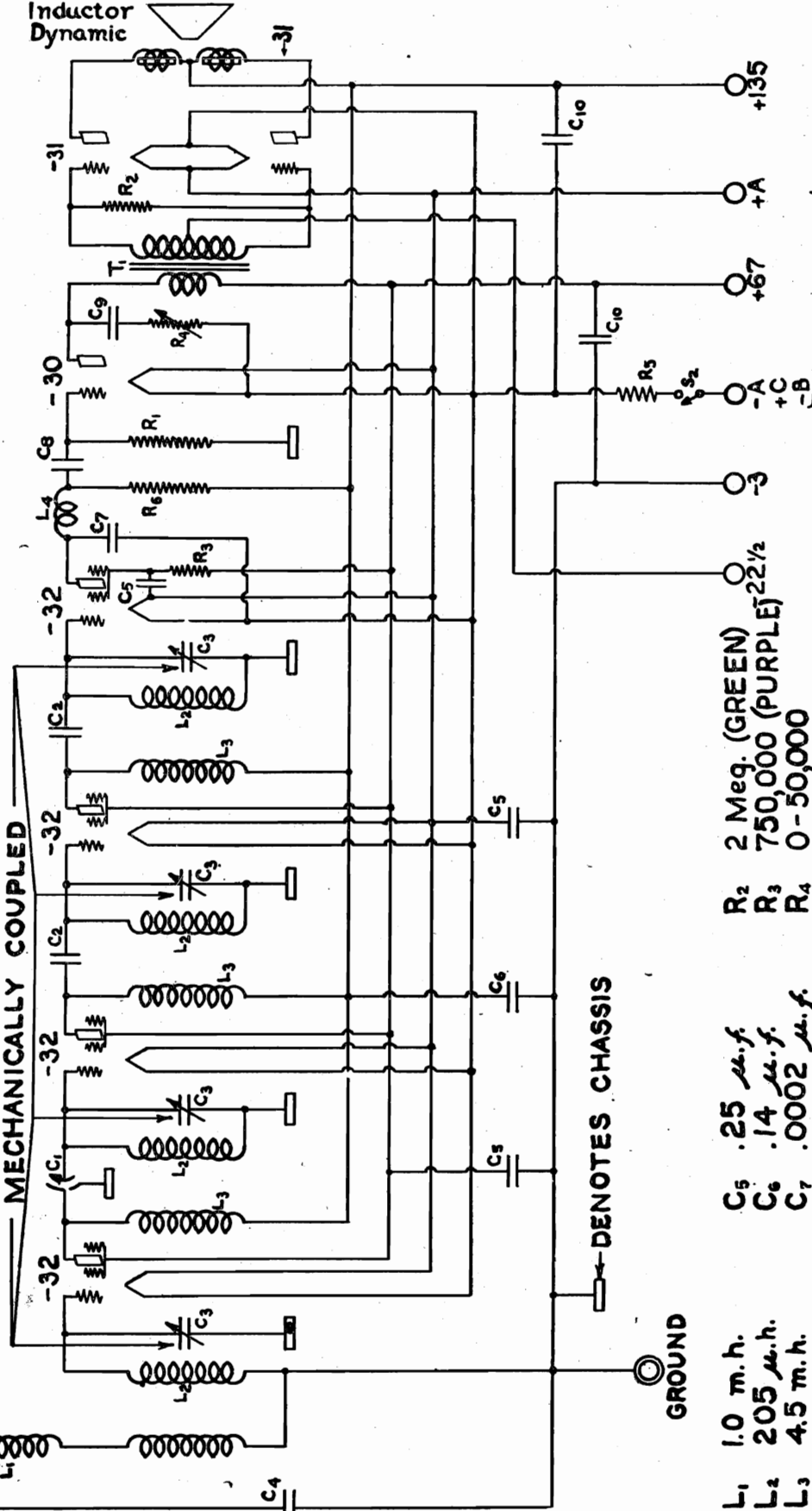

2½ V. "AIRCELL"
or equivalent battery

CA-7022
6%

MECHANICALLY COUPLED

⊞ DENOTES CHASSIS

⊙ GROUND

- L₁ 1.0 m. h.
- L₂ 205 μ. h.
- L₃ 4.5 m. h.
- L₄ 65 m. h.
- C₁ 0-10 μ. μ. f.
- C₂ 10 μ. μ. f.
- C₃ 425 μ. μ. f. Max.
- C₄ .0002 μ. f.
- C₅ .25 μ. f.
- C₆ .14 μ. f.
- C₇ .0002 μ. f.
- C₈ .02 μ. f.
- C₉ .03 μ. f.
- C₁₀ 1.0 μ. f.
- C₁₁ 10 μ. μ. f.
- R₁ 500,000 (BLACK)
- R₂ 2 Meg. (GREEN)
- R₃ 750,000 (PURPLE)
- R₄ 22½
- R₅ 0-50,000
- R₆ 0.6
- R₇ 250,000 (BLUE)
- S₁ H.&H. 3 Point Switch
- S₂ H.&H. 2 Point Switch
- T₁ 2:1 P.P. Transformer.

MODEL 15-B Voltage and Socket Layout

BRUNSWICK RADIO CORP.

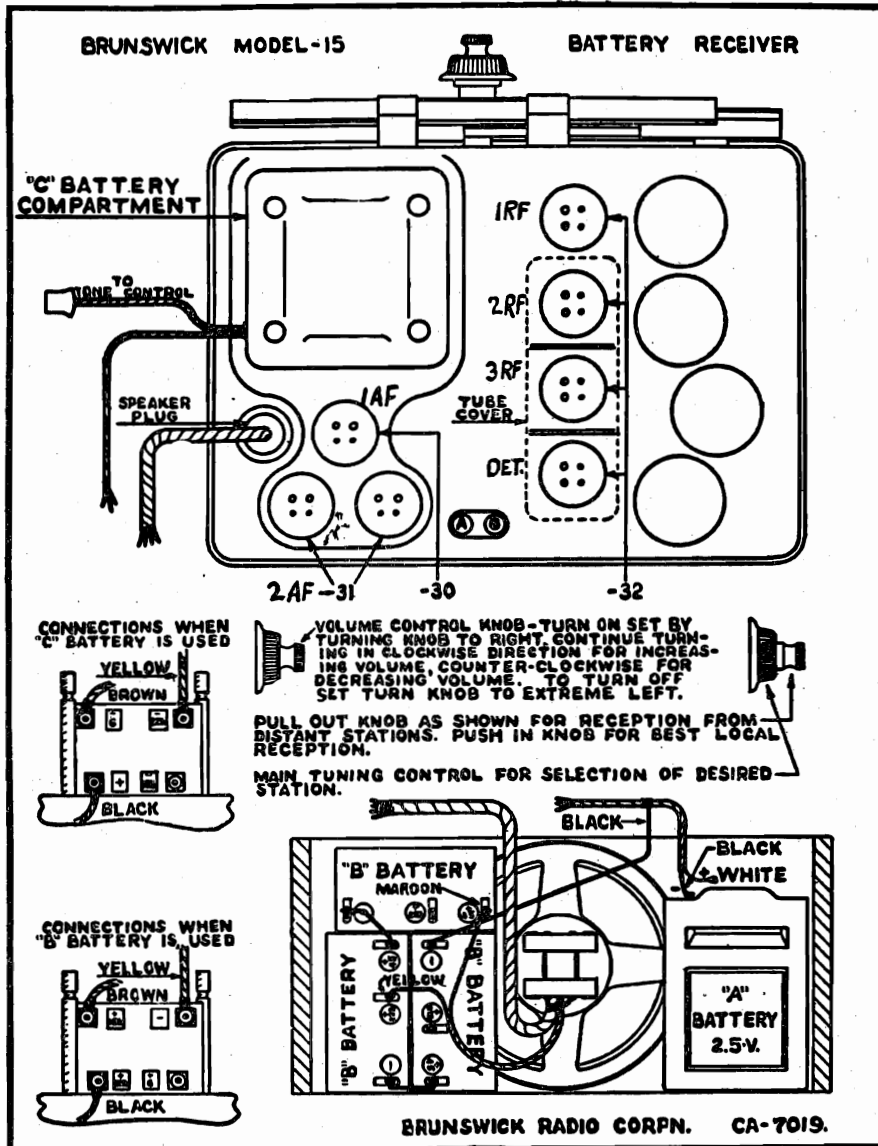

Tube Position	Filament Voltage	Plate Voltage	Plate Current	Screen Grid Voltage	Control Grid Voltage
1st R. F.	2. volts	135 volts	1.1 M. A.	69 volts	-3 volt
2nd R. F.	2. "	135 "	1.1 M. A.	69 "	-3 "
3rd R. F.	2. "	135 "	1.1 M. A.	69 "	-3 "
Detector	2. "	67.5 "	.03 M. A.	69 "	-3 "
1st Audio	2. "	67.5 "	2.4 M. A.	--	-3 "
Power amp.	2. "	135. "	6.2 M. A.	--	-22.5"
" "	2. "	135. "	6.2 M. A.	--	-22.5"

NOTE:

(*) Because of the large resistance in the plate and screen grid circuit of this tube, the voltage reading on most analyzers will be in the neighborhood of 5. volts.

MODEL 15, 22, 32 DC
 Socket and Voltage
 Data
 Used in Model 42 DC

BRUNSWICK RADIO CORP.

MODEL DC - 32

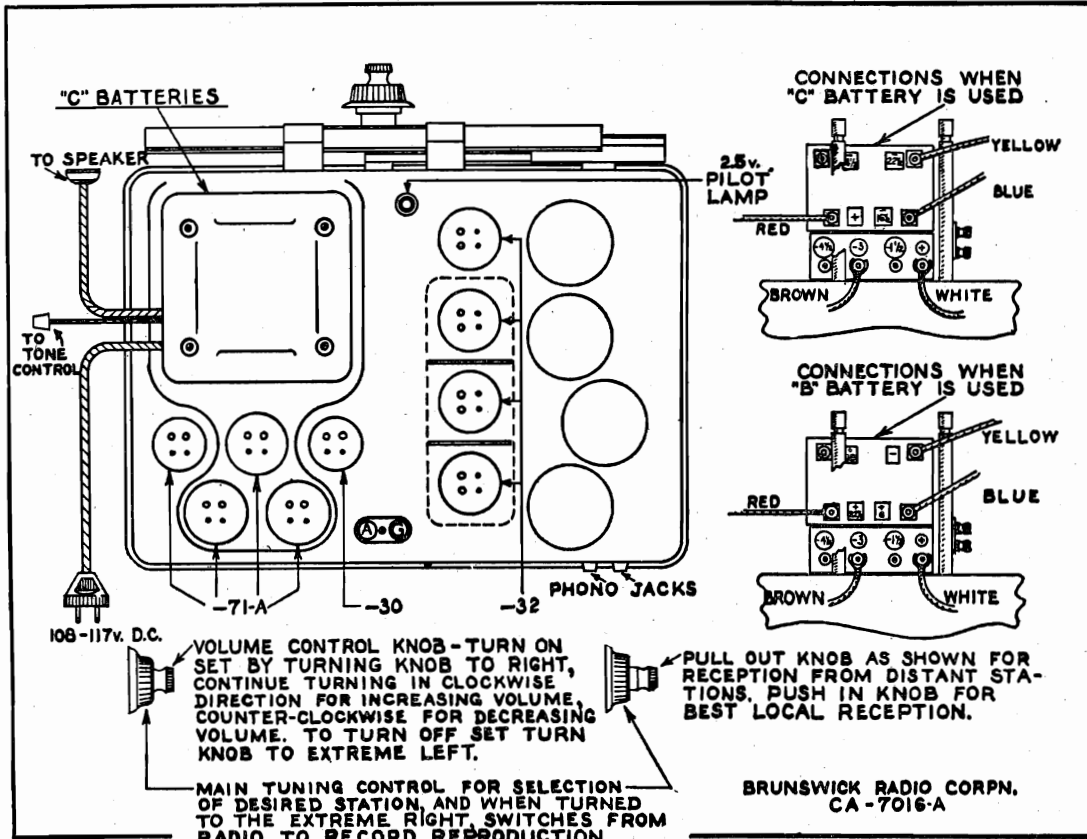

TUBE SOCKET ANALYSIS

For Models DC-15, 22 and DC-32

The values given in the following table are correct for standard analyzers on 118-volt direct current lines:

Tube Position	Filament Voltage	Plate Voltage	Plate Current	Screen Grid Voltage	Control Grid Voltage
1st R. F.	2.1 volt	100 Volt	1.4 M. A.	50	-3 volts
2nd R. F.	2.1 volt	100 Volt	1.4 M. A.	50	-3 volts
3rd R. F.	2.1 volt	100 volt	1.4 M. A.	50	-3 volts
Detector	2.1 volt	23 volt	.2 M. A.	50*	-5 volts*
1st Audio	2.1 volt	62 volt	2. M. A.	--	-3 volts**
Pwr. rear right	5.2 volt	112 volt	13. M. A.	--	17. volts
" rear left	5.2 volt	110 volt	14. M. A.	--	22. volts
" front right	5.1 volt	111 volt	11. M. A.	--	22. volts
" front left	5.1 volt	110 volt	11. M. A.	--	17.5 volts

NOTE: (*) Because of the high resistance in this circuit a much lower reading will be obtained on most analyzers.

(**) A potentiometer, located on the under side of the audio panel, varies this grid-bias and should be adjusted to give the above voltage.

BRUNSWICK RADIO CORP.

MODEL 15, 22, 32 DC
Schematic
Used in Model 42 DC

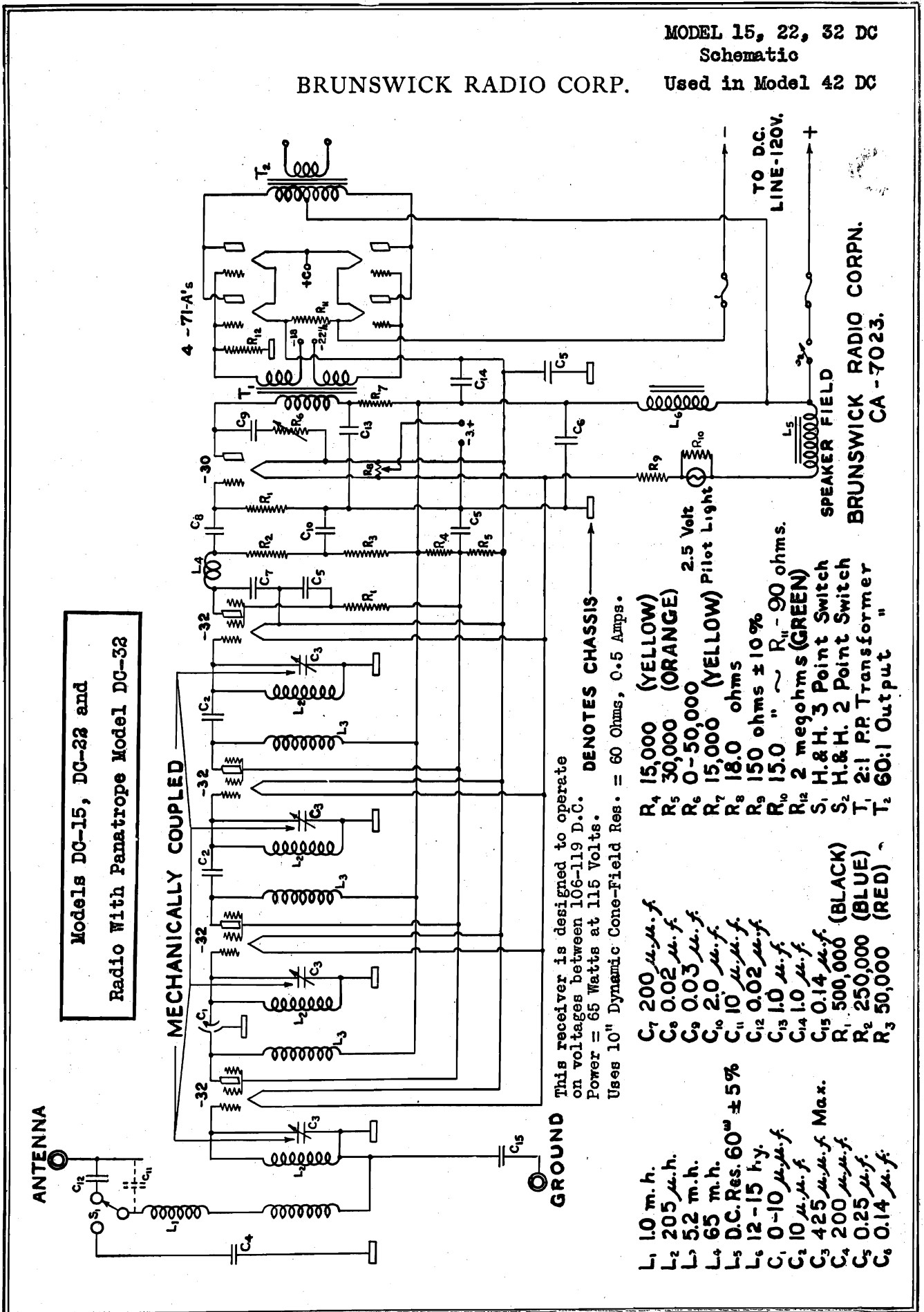

Models DC-15, DC-22 and
Radio With Panatropo Model DC-32

MECHANICALLY COUPLED

This receiver is designed to operate on voltages between 106-119 D.C. Power = 65 Watts at 115 Volts. Uses 10" Dynamic Cone-Field Res. = 60 Ohms, 0.5 Amps. DENOTES CHASSIS

- L₁ 1.0 m. h.
- L₂ 205 μ. h.
- L₃ 5.2 m. h.
- L₄ 65 m. h.
- L₅ D.C. Res. 60^ω ± 5%
- L₆ 12 - 15 h. y.
- C₁ 0 - 10 μ. m. f.
- C₂ 10 μ. m. f.
- C₃ 425 μ. m. f. Max.
- C₄ 200 μ. m. f.
- C₅ 0.25 μ. m. f.
- C₆ 0.14 μ. m. f.
- C₇ 200 μ. m. f.
- C₈ 0.02 μ. m. f.
- C₉ 0.03 μ. m. f.
- C₁₀ 2.0 μ. m. f.
- C₁₁ 10 μ. m. f.
- C₁₂ 0.02 μ. m. f.
- C₁₃ 1.0 μ. m. f.
- C₁₄ 1.0 μ. m. f.
- C₁₅ 0.14 μ. m. f.
- R₁ 500,000 (BLACK)
- R₂ 250,000 (BLUE)
- R₃ 50,000 (RED)
- R₄ 15,000 (YELLOW)
- R₅ 30,000 (ORANGE)
- R₆ 0 - 50,000
- R₇ 15,000 (YELLOW) Pilot Light
- R₈ 18.0 ohms
- R₉ 150 ohms ± 10%
- R₁₀ 15.0 " ~ R₁₁ - 90 ohms.
- R₁₂ 2 megohms (GREEN)
- S₁ H.&H. 3 Point Switch
- S₂ H.&H. 2 Point Switch
- T₁ 2:1 P.P. Transformer
- T₂ 60:1 Output "

BRUNSWICK RADIO CORPN.
CA - 7023.

BRUNSWICK RADIO CORPORATION

MODEL 100
Short Wave
Converter

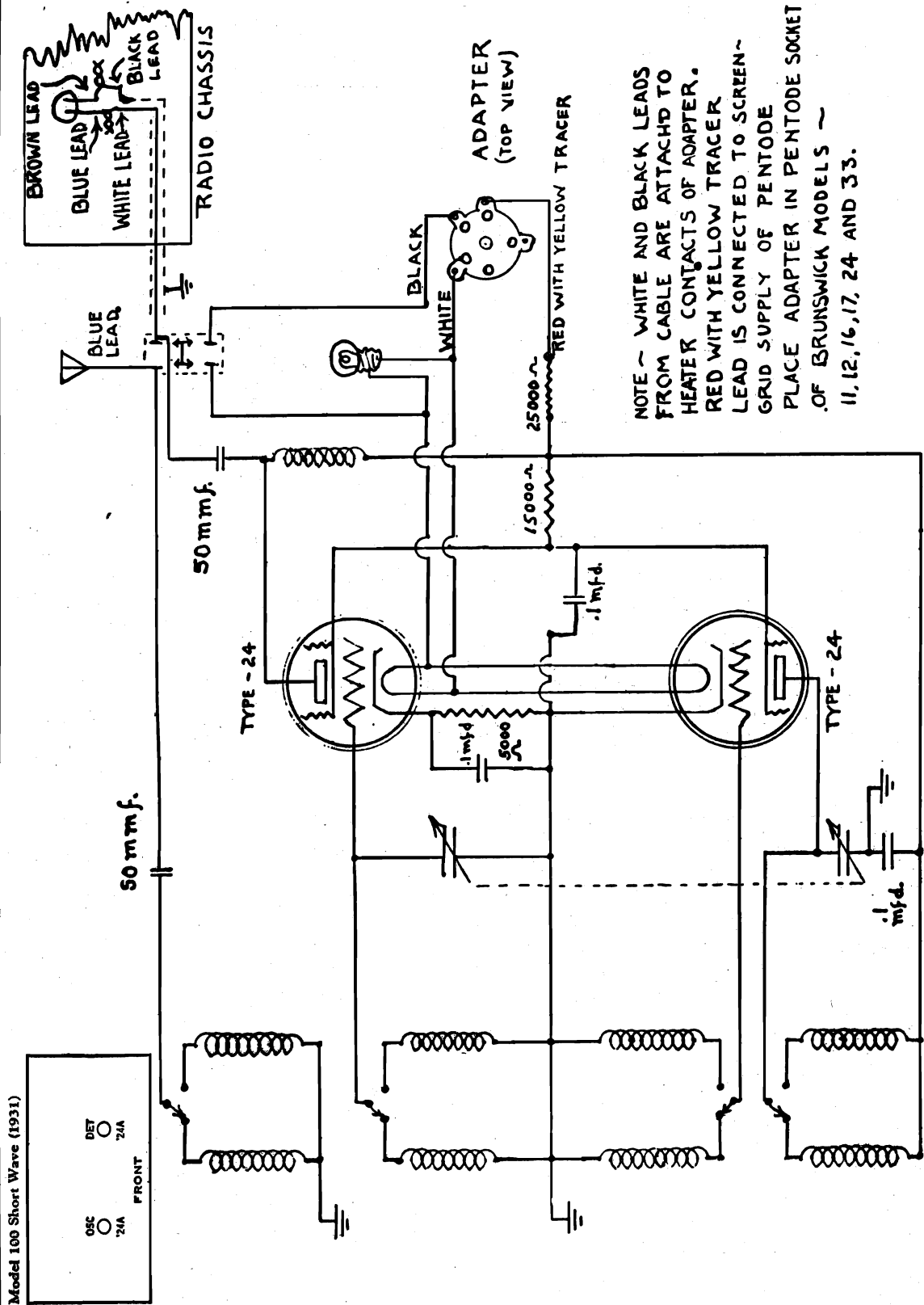

NOTE - WHITE AND BLACK LEADS FROM CABLE ARE ATTACHED TO HEATER CONTACTS OF ADAPTER. RED WITH YELLOW TRACER LEAD IS CONNECTED TO SCREEN-GRID SUPPLY OF PENTODE. PLACE ADAPTER IN PENTODE SOCKET OF BRUNSWICK MODELS - 11, 12, 16, 17, 24 AND 33.

BRUNSWICK MODEL-100 SHORT-WAVE CONVERTER

CA-7039

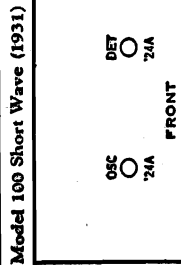

MODEL 42
AC-DC

BRUNSWICK RADIO CORP.

BRUNSWICK AUTOMATIC PANATROPE WITH RADIO

PART I
ELECTRICAL SPECIFICATIONS
MODEL 42

Rating.....	105 to 130 volts—60 cycles
Also available.....	105 to 130 volts—50 cycles
	105 to 130 volts—25 cycles
	105 to 125 volts—direct current
Power consumption of radio set—60 cycles.....85 watts
Power consumption of Panatrope and Radio.....110 watts
Type of circuit.....	Screen-grid tuned radio frequency
Type of tubes.....	—80.....1
	—45.....2
	—24.....4
Recommended antenna length.....4.0 micro volts per meter
Average sensitivity.....3
Number of radio frequency stages.....	Linear type—power detector
Type of detection.....1
Number of audio stages.....	Parallel operated—45's
Type of audio amplification.....125 ma. full wave type—80
Type of rectifier.....10-inch cone—dynamic
Type of loudspeaker.....	Series connected—1600 ohms—100 volts—drop—62.5 ma.—6.25 watts
Speaker field.....	

INTRODUCTION

The Brunswick Model 42 Automatic incorporates the same armored chassis and dynamic speaker that is used in the Models 15 and 22. In addition it has the added feature of the Automatic Panatrope which will play twenty records without attention, and then shut itself off.

It is the purpose of this bulletin to show only those features which deal with the Automatic equipment, its connections to the radio chassis, and also the information dealing with coin operation. All other data on the radio set can be obtained from Service Bulletin No. 71.

The operation of the Automatic Panatrope is extremely simple, as will be readily seen by the following explanation:

Figures 1 and 2 show top and front views of the Model 42 and indicate the various components that enter into its use.

With the station selector control turned past the 1500 K. C. mark, and twenty or less records in the record magazine, turn the



Fig. 1

"off" and "on" switch to the "on" position. Then press the "start" button. This will do the following: connect the power to the radio chassis so that the audio amplifier can be used for record reproduction; starts the motor and automatic mechanism for the cycles of playing the record and ejecting the played record into the reject compartment.

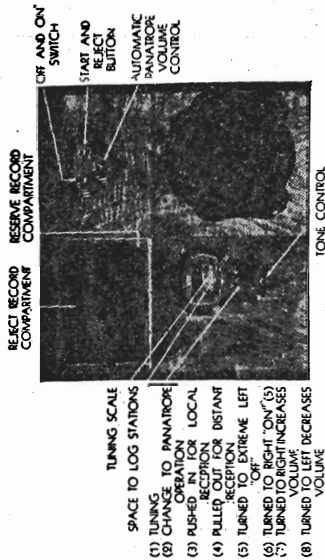

Fig. 2

PART II
THE STORY OF THE AUTOMATIC AND ITS OPERATION THROUGH A COMPLETE CYCLE

The accompanying series of sketches have been prepared in order to present a clear idea of the cycle of operations through which the Automatic mechanism goes during the playing, the rejection of a record, and the starting of a new record. In conjunction with the following explanation, these sketches should make what appears to be a complicated mechanism really a very simple piece of apparatus. An automatic record playing instrument may be made in innumerable ways, but the simplicity of its mechanism reflects the true engineering skill behind it. There should be no more apparatus necessary than that required to accomplish the purpose of the machine. In servicing such a machine, this is a factor to be appreciated.

In Sketch 1 the record is shown in the playing position. As the magnetic pickup moves toward the center of the record, beneath the top plate of the mechanism the suspension arm is pulling a special switch with it. This is shown in Sketch 2. When the end of the record is reached, this switch hits against an adjustable stop, closing the switch contacts.

From this point on, many things occur in a short space of time, ten seconds or less. Reference to the schematic circuit appearing in Figure 6 will also help to clear up a few points. In fact, it will more than pay the person who meets up with this model to sit down and follow out this circuit along with this description.

The switch just mentioned is designated as the "Suspension Arm Switch" in the schematic circuit. When this closes, the line voltage is placed directly across the solenoid coil, also shown in Sketch 3. Immediately the solenoid armature pulls the stop lever from the dotted line to the solid line position. The projection "r" on this lever (follow to Sketch 4) moves out of the way of the clutch pawl, allowing the latter under the tension of the small spring to slip in and engage with the teeth of the clutch. The only revolving parts up to now have been the motor, ejector friction disc, and the turntable. Sketch 5 shows the parts which start revolving when the clutch engages. A little further on, the reason for these gears will become evident.

As the master gear revolves, three cams on its under side function. The first is shown in Sketch 6, operating the cycle switch. This switch closes (refer to schematic circuit and

MODEL 42

AC-DC

BRUNSWICK RADIO CORP.

steadily. The oil holes are located directly beneath the turntable. A few drops will suffice; do not flood the motor with oil as this can do more harm than good.

The Brunswick Permo-Point needle, which accompanies each instrument, will play in excess of 2,000 records. It is recommended that this needle be used in preference to all other types.

Some of the simple adjustments which may be necessary to accommodate slight differences in records, as well as some suggestions to take care of possible changes caused by shipment, are given below.

We recommend that the first time any of these adjustments are made, that the plate covering the mechanism be removed. This can be accomplished as follows:

- (a) Lift off the turntable.
- (b) Remove all screws around the edge of plate covering mechanism, as well as those around the suspension arm.
- (c) Remove the nut which holds the suspension arm to the cast iron base.
- (d) Carefully lift up the suspension arm about three-quarters of an inch and remove the plate by pulling up the front end and gently lifting out—taking care not to mar the cabinet. Removing this plate will bring the mechanism into view, permitting the adjustment of four primary points.

1. Adjustment determining the point at which the magnetic pickup is lowered to edge of record.
Replace the turntable, re-tighten suspension arm nut, and place a record in the record magazine; press the start button. As the master gear starts through the last half revolution (see Sketch 8) it will be seen that the eccentric stop "s," controls the release of the lever "w," which is pulling the suspension arm toward the record. The adjustment of this "stop" allows the needle of the magnetic pickup to drop on the edge of the record about a sixteenth of an inch from the grooves.
2. Also in Sketch No. 8 there will be seen a spring, "q."
After the needle has come in contact with the record, this spring pulls the suspension arm over until the needle rides in the starting grooves of the record. If the spring tension be too great, the needle may jump several grooves, or on the other hand, if it is too weak, will not pull the needle into the starting grooves at all. The earlier models with serial numbers up to 2,000 have this spring attached to a fixed stud and the tension can be varied by shortening or stretching the spring. Those with serial numbers above this have an adjustable bracket to which the spring is attached, permitting the tension to be varied without touching the spring. The remedy is obvious.

3. At the base of the suspension arm, see Sketch No. 2, is a switch which controls the rejection of a record at the finish of its playing. There are two types of these switches, the earlier type—on models with serial numbers less than 2,000 (this type is shown on the actual wiring diagram Figure 5)—and the later one that is indicated in Sketch 2.

Removing the cover, the action of this switch can be observed. As the record plays, the switch casting is slowly carried along with the suspension arm. In the earlier type of switch the floating contact member does not touch either side contact until the magnetic pickup reaches either the inside groove of a concentric grooved record where a stop (see Sketch 2) causes the left contact to close; or on an eccentric grooved record will cause the right contact to be closed. If either of these two contacts are too close to the floating contact there is a possibility of the record rejecting before it is finished. Also, if the separation from the right

note that the "reset" and "off-on" switches are closed) in order to maintain a closed power circuit to the motor when the "reset" switch opens a little later. Immediately thereafter, the second cam on the master gear, not shown, has revolved to a position where it actuates a lever raising the pickup arm, see Sketch 6.

Referring to Sketch 7—with the pickup raised off the record, the third cam raises the ejector wheel to a position where the friction cone rides on the ejector friction disc. As the ejector wheel comes up and starts to revolve, it also brings up the push rod opening the "reset" switch (see schematic). The revolving ejector wheel sends the finished record out into the reject record compartment.

In Sketch 8, note the lever arm marked "l." Functioning through its mechanical connection to the master gear, it starts moving the pickup suspension arm out of the way of the next record coming down from the magazine. The levers "x," and "y," are also working at the same time and through the connecting rod "z," as the pickup moves to the right, sends a new record down to the turntable. Sketches 8 and 9 show the respective positions of the mechanism and top of the Automatic Panatropes at the middle of the record change operation. The master gear only revolves once. The reason for the two reduction gears, Sketch 5, should now be apparent; namely, because the turntable shaft revolves at 78 R.P.M., and this speed is entirely too high for direct application to the other moving parts, suspension arm, etc. Even if it were, the size of the motor would have to be much greater to supply all the power required during the record change. The gears serve to keep the power consumption of the Panatropes down to a minimum.

When the new record drops on the turntable, it hits the push rod closing the "reset" switch, thus keeping the power circuit to the motor and chassis closed even though the cycle switch is still closed. The position of the record, ejector wheel and push rod are now shown by Sketch 10.

Going back to Sketch 8, the suspension arm return lever, "w," now comes into play. This is during the last half of the master gear revolution. As the master gear returns to its original position, the suspension arm return lever, "w," catches the projecting pin that was pushed over by "l," carrying the suspension arm back until the other end of "w" hits the stud "s." This releases the pin, leaving the suspension arm and pickup in position over the first grooves of the new record. With the return of the suspension arm, the arm "v" in the record magazine has moved back ready to advance the next record. The pickup is lowered to the record and the master gear, completing its cycle, allows the stop lever arm to drop to the position indicated by the solid lines of Sketch 11 under the tension of the spring "u." The projection "r," Sketch 3, engages the clutch pawl, preventing the gears from revolving further. The cycle switch opens and the new record continues the program.

There is one more point to consider. Had the record magazine been empty, the mechanism would have worked in the same manner with one exception, the push rod would have remained up and the "reset" switch open. From the schematic circuit, it is evident that upon the opening of the cycle switch, the power supply circuit is broken and the whole machine shuts off.

PART III

ADJUSTMENT AND CARE

All initial adjustments are made at the factory so that the instrument is ready for immediate use when properly installed. The turntable speed should be 78 R.P.M., but if for any reason it is thought that this speed is not being maintained, by placing a paper clip at some point on the record's edge for an indicator and timing the turntable, it is possible to check this. The motor speed control is directly above the motor and is readily located when the cabinet back is removed.

The motor should be oiled about once a month; a little oftener if the machine is used

MODEL 42
AC-DC

BRUNSWICK RADIO CORP.

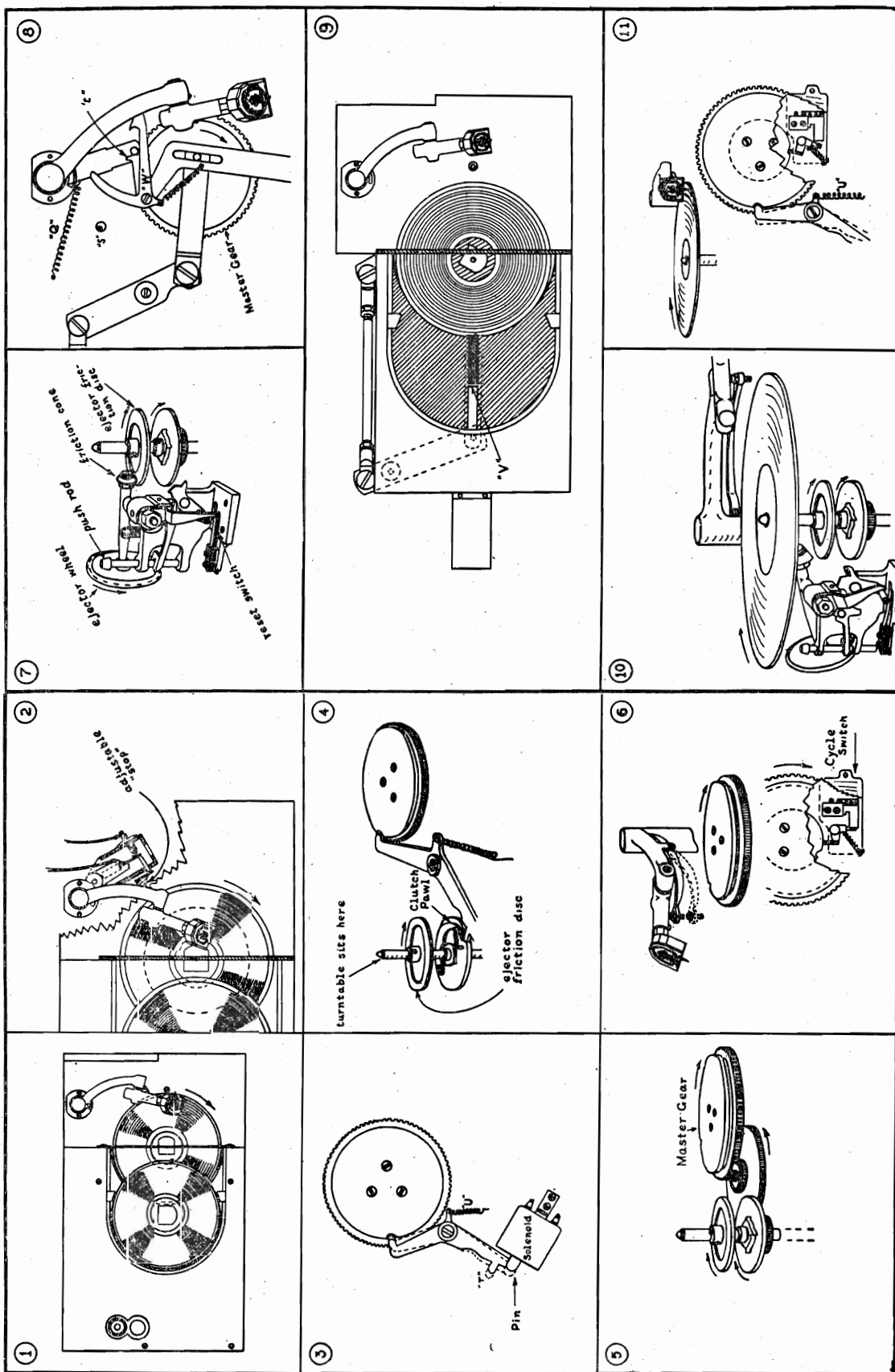

Figure 4

Figure 3

**MODEL 42
AC-DC**

BRUNSWICK RADIO CORP.

contact is too great, the switch will not close on an eccentrically grooved record. If the stop for the concentric grooved record is set too far to the left the contact will not close, and if set too far to the right, the record is rejected before the selection finishes.

The later type of switch has been simplified somewhat in construction, having only one contact, but accomplishes the same work. If the previous discussion has been carefully followed, similar reasoning applies to the adjustment and operation of this later type of switch. On the models with this later type switch the "stop" previously mentioned is adjustable through a hole in the plate covering the mechanism.

4. Solenoid operation:

Remove the turntable and press the start button. This energizes the solenoid coil which in turn operates the lever, which starts the functioning of the record-changing mechanism. After the record-changing mechanism completes its cycle, the electrical circuit of the solenoid is opened and it is de-energized. The spring, "u," sketch 11, pulls the lever into its normal position. If the solenoid for any reason does not draw the armature in properly, or the armature vibrates against the solenoid, it can be adjusted by means of the two screws which mount the solenoid to the base. Also, if the spring "u" is too weak, the record-changing mechanism will not stop, but will continue to reject the records. If too strong, the solenoid will not have sufficient power to operate the record-changing mechanism. The solenoid armature is hollow and contains a rubber bumper which dampens out alternating current vibrations.

GENERAL POINTS TO CHECK UP IF THE AUTOMATIC PANATROPE IS INOPERATIVE

1. Be sure that the power line plug is connected to the receptacle and that this is "alive." The latter can be readily determined by plugging in a floor lamp or other similar electrical device.
 2. The power plug joining the Automatic mechanism and radio chassis should be solidly connected.
 3. The Panatrope input transformer tip leads should be well seated in the tip jacks at the rear of the radio chassis.
 4. There should be not more than twenty records in the magazine and reject record compartment at one time to prevent the possibility of jamming and record breakage.
 5. The "Off-On" switch on the Panatrope control panel should be placed at the "On" position, and the volume control turned up far enough to insure sufficient volume.
 6. The station selector scale should be turned past the 1500 K. C. mark until the clicks of the Radio-Panatrope change-over switches are heard.
 7. By pressing the "start" button for an instant, the radio tuning scale should be illuminated and the turntable set in motion. If the latter revolves, but the scale is not illuminated, the fuses under the power transformer cover should be tested and any defective ones replaced. Check the pilot light for continuity if the radio tubes light up.
 8. If everything checks up to this point, and still no reproduction is obtained, see that the group of three tubes at the left of the radio chassis (when viewed from the rear) are lighted. Remove the cover on the three screen-grid tubes and replace the tube nearest the rear of the chassis with one known to be okay.
 9. For pickup trouble see Service Bulletin No. 70, page 9.
- In conjunction with the following possibilities of trouble and their remedies, it would be well for the one contemplating service on the instrument to stop for a moment before

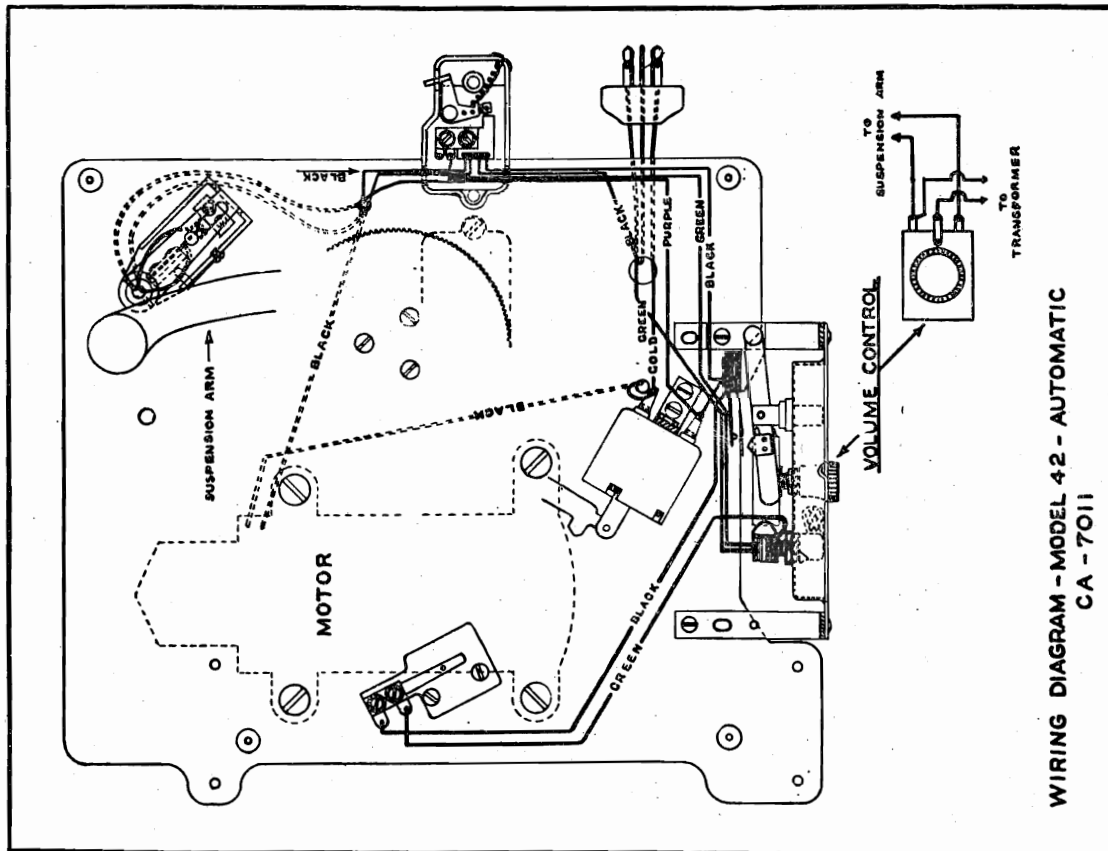

**WIRING DIAGRAM - MODEL 42 - AUTOMATIC
CA - 7011**

Figure 5

MODEL 42
AC-DC

BRUNSWICK RADIO CORP.

delving into the machine and try to analyze the cause of the trouble. This will save much time and unnecessary work.

Records Jamming in Mechanism

There are several conditions which may cause this; the most likely are those due to (a) warped records, (b) the record feed fingers on the record magazine bent, (c) the spring on the record gate (which supports the records while stored in the magazine) adjusted too closely, allowing only thin records to pass through; or the other extreme, too wide, allowing two records to go through, (d) the space under the record feed fingers allows two records to be caught instead of a single one.

Obviously, for (a) the record should be placed on a warm flat surface until it is once more flat. For (b) it will be necessary to remove the mechanism from the cabinet (see paragraph headed "Removal of Mechanism from Cabinet") to get at the small spring which provides tension for this finger. After once seeing how this particular part functions, the average service man can effect the repair by running the mechanism to the middle of a cycle, at which point the record feed finger will be at the edge of the magazine. If the spring is broken and enough remains to permit stretching it, too much tension will not be a serious drawback on the finger; otherwise, it is necessary to replace the spring with a similar one. For (c) refer to Figure 1. This shows the record gate in question, situated immediately over the center of the record on the turntable. This has a spring clip at its center which is adjustable either up or down. To adjust for two records coming through at once, lower the gate, and for a single thick record raise it. If records of standard make, and not warped, are used, very little trouble will be experienced from this point after it is once set. In a few cases (d) it has been found that the space under the record feed finger of the magazine lever permits two records to be caught at once. Should this be the case, the part of the lever which goes under the record first can be raised a small amount, thus lowering the height of the finger when it comes forward to select the next record for reproduction. In case the turntable does not revolve after these troubles have been remedied, turn the motor governor by hand until the mechanism reaches the start position; then it will run as usual.

Adjustment of Feeder Rod

The feeder rod is located at the back of the automatic mechanism, and is made accessible by removing the wooden top cover around the record magazine. Also refer to Sketch 9. Its length controls the distance through which the magazine lever moves. This does not often need attention but can be changed in length as follows: Loosen the lock nuts at either end of the rod. To shorten, turn the rod in a clockwise direction, or in case the rod is to be lengthened, turn in a counter-clockwise direction. Then tighten the lock nuts.

Record Ejector Wheel Not Functioning Properly

Sometimes the record ejector wheel will come up but fail to turn and throw the record out. This may be due to neglect in oiling the shaft to which it is attached. As this is only a friction drive, any opposition to its turning, in addition to the ejection of the record, may be detrimental. Other possibilities are that the friction cone is covered with oil, or is worn down. Clean it off and check before going further. If it has worn down, check the spring in the plunger which pushes this wheel up. See that this spring has some life in it by noting whether the ejector wheel rebounds readily when pushed down. If, after this the trouble is not obvious, try placing a very thin washer behind the friction cone to move it forward a little or replace the cone.

Solenoid Trouble

Vibration during record changing cycle. This may be due to the solenoid being improperly centered, or caused by the rubber bumper in the hollow solenoid armature not functioning properly. Loosen the screws which hold the solenoid to the iron base, and push it forward.

Center the plunger pin and tighten the two screws. Check the smoothness of the plunger action by operating it with the finger. It is absolutely essential that the armature be properly centered. It may even be necessary to place a small piece of paper beneath the bracket near either of the two screws, or one side of the bracket to center it, but be sure it is finally centered. If the solenoid rattles after this, take the armature out and determine whether the rubber has lost its elasticity, due to excessive heat or moisture. If so, replace it and center the solenoid again. Also see "Solenoid Operation" at beginning of Part III. For an open winding in the solenoid there is no alternative but to replace the coil.

Gear and Clutch Mechanism--Cycle Switch

This is the heart of the whole mechanism. Once properly set, the likelihood of its causing trouble is small. If for any reason it becomes necessary to remove the gears, the easiest way to reset the timing is to loosen the solenoid, set the solenoid stop lever (see Sketches 3 and 4) in a position such that it has the projection "r" directly over the slot in the clutch disc. To do this it will be necessary to unfasten the solenoid lever. Raise the master gear sufficiently to clear the intermediate gear and rotate it to a position such that the end of the stop lever is in position near the slot in the master gear. Lower the master gear so that it engages the intermediate gear cogs and then drop the stop lever into position. Set the stop lever snugly in place in the slot of the clutch disc. At this point, the clutch pawl is disengaged from the clutch. If this is not possible, raise the stop lever arm and master gear again and move the latter a single cog or two in the direction which will permit the stop lever to fit properly, then set the stop lever in place and fasten down the master gear by means of the nut under the base. It may be necessary to try this procedure several times before getting perfect operation, but once it has been successfully accomplished, it will be an easy point to tackle afterwards. In case it is found that the two gear segments on the intermediate gear have become loose within each other, this part should be replaced.

The cycle switch is shown in Sketch 6, and has only one moving contact. In the event this remains open circuited, the mechanism will stop just after the rejected record has left the turntable and before the next record drops down from the magazine.

Ejector Wheel Push Rod Assembly

The case may arise where the push rod does not come up high enough to open the reset switch. First, check this rod for bends by turning it around with the finger when it is in the upper position. If it is bent, carefully straighten the push rod and apply a slight amount of oil at the guide holes. The spring tension needs very little adjusting, and if the whole assembly is oiled once every six months, it should give no trouble. Also see latter part of paragraph under heading of "Record Ejector Wheel not Functioning Properly."

Removal of Mechanism From Cabinet

Wherever it is necessary to remove the entire mechanism from the cabinet, the following procedure should be followed:

1. Disconnect the instrument from the power line, and also open the power and Panatone plug connections between the radio chassis and the Automatic mechanism.
2. Four large nuts hold the mechanism in the cabinet, these being located at the four corners of the cast iron base. Remove these and the rubber cushions.
3. Remove the volume control knob on the control panel.
4. Remove the four screws that fasten the lid supports to the top cover of the cabinet, and gently lay the cover back.
5. Remove the wooden top piece which contains the "good" and "used" needle receptacles.

This exposes the entire mechanism and permits its removal from the cabinet.

MODEL 42
AC-DC

BRUNSWICK RADIO CORP.

PART IV COIN OPERATION

A coin operation kit has been made up, designated as Part No. 1000, for use in conjunction with the Automatic Panatropie mechanism. Full instructions accompany each kit showing the connections and physical locations of each part.

This equipment will permit the Panatropie to reproduce one record for each nickel inserted up to the capacity of the magazine—twenty records. The coin control device is actuated by the feeder rod at the back of the mechanism. If the machine is used exclusively for coin operation, the "Off-On" switch should be disconnected from the circuit behind the panel to prevent the whole magazine contents from playing on a single coin.

Connection to the circuit is extremely simple, as all that need be done is to separate the power plug from the chassis to mechanism and insert the extension plug provided with the apparatus. This layout and the connections are given in the accompanying diagram.

As this equipment is of rugged construction, it will give very little trouble. The most important point to check is to be sure the actuating lever is securely fastened to the protruding arm of the lever box. This lever normally assumes a vertical position and the ratchet wheel moves one notch with each record played. An improper placing of this lever results in either too much strain on it, or else it does not move the ratchet wheel.

Complete installation instructions are supplied with each coin operation kit which may be purchased from any Brunswick Distributor or Branch.

PART V

12-INCH RECORD OPERATION

Prior to Serial No. 2500 the Model 42 Automatic Panatropie with Radio was not provided with a means for playing 12-inch records. A demand on the part of music lovers, who already had a library of 12-inch records, however, made it advisable to provide manual operation for 12-inch records. A kit of the necessary parts to make this change may be ordered from any Brunswick Distributor or Branch by specifying Part No. 4464. Directions for attaching these parts are as follows:

DIRECTIONS FOR INSTALLING PART NO. 4464 KIT ON MODEL 42 AUTOMATIC PANATROPIE WITH RADIO TO PERMIT MANUAL OPERATION OF TWELVE INCH RECORDS

Parts Required:

- 1 Twelve-inch Record Kit (Part No. 4464) consisting of:
 - 1 Record guide plate assembly (right).
 - 1 Record guide plate assembly (left).
 - 2 Record guide screw-plates, with screws.
 - 1 Switch cam and record locator assembly.

Tools Required:

- 1 Hack-saw with proper blades for cutting 3-16-inch steel stock
- 1 Hand drill and the following drills, sizes:
 - 1—3-32" drill
 - 1—3-32" drill
 - 1—12-inch flat file
 - 1—8-inch Bastard file.

The usual assortment of screwdrivers, pliers, soldering iron, etc., available in every service department.

All of the above tools should be at hand before the installation of this kit is attempted.

2. Cut Triangular-Shaped Slot in Record Hopper:

- (a) From the dimensions given in Figure No. 9 Page 16, (see detail "b") mark in pencil the exact shape of the cut to be made on the front record hopper support (note that only the front support is to be so cut). The important dimensions are the base line (1½-inch above the turned in portion of the record hopper leg), the length of the base line (17½-inch long as a minimum and 2-inches long as a maximum), the width of the cut at the front (7½-inch to 1-inch wide) and the angle at which the top of the cut intersects the base line (the easiest way to draw this is to make the cut ½-inch deep at the inside).

- (b) Remove the two record-guide arms from the record hopper cross bar and remove the record hopper cross bar from the record hopper.

- (c) After marking the proposed shape of the cut on the front leg of the record hopper, as directed in paragraph "a" above, saw along the two horizontal lines with a hack-saw until the inside vertical line is reached. Then bend the piece of metal to be removed back and forth until it breaks off. File the edges smooth. (d) File the protruding edges of the record hopper (indicated by "c" on the drawing) back at a 30-degree angle so that these points will not scratch the 12-inch records when they are placed on and removed from the turntable.

- (e) Fasten the record hopper cross bar and the two adjustable record guides (supplied with the kit) on the record hopper by means of the four machine screws and the two screw blocks (also supplied with the kit).

3. Fasten New Record Bumper and Switch Assembly to Top Plate:

- (a) Remove the eight machine screws that fasten the right hand top plate to the record-change mechanism; the two machine screws that hold the suspension arm collar to the top plate and remove the top plate.

To Play 12-inch Records Manually:

1. Turn station selector scale past the 1500 kilocycle mark until a click is heard and turn the "off-on" switch on the automatic panatropie control panel to the "on" position.
2. Turn the two 10-inch record guide arms, located on opposite sides of the record hopper, up, and rotate the rubber-covered record bumper (located at the right of the turntable) toward the right-hand side of the cabinet as far as it will go, so as to allow 12-inch record to fit on turntable.
3. Move the magnetic pickup toward the right-hand side of the cabinet as far as it will go and gently slide the 12-inch record on the turntable from the right side of the cabinet.
4. The magnetic pickup can now be freely moved, and by placing it in the first playing groove of the record the 12-inch records can be played.

To Change Back for 10-inch Record Automatic Operation:

- Turn the record guide arms, located on the record hopper, down, and rotate the rubber-covered record bumper arm in toward the turntable. The instrument will now play 10-inch records automatically.

- (b) Remove the rubber-covered record bumper from the top plate and also remove the rivet 9-16-inch above the record bumper hole.
- (c) Remove the rubber-covered adjustable record bumper and switch throw cam from the switch assembly supplied with the kit so that the base plate may be used as a template.
- (d) Fasten the base plate of the switch to the under side of the top plate (the switch should be mounted toward the outside edge of the top plate) using the two holes provided by the removal of the rubber-covered record bumper and the rivet (these two holes are referred to as "a" and "b" in the diagram).

- (e) Mark the location of the third hole (referred to as "c" in Figure No. 9) with a punch, remove the switch plate and drill this hole with a 11-64-inch or 3-16-inch drill.
- (f) The switch may now be assembled on the top plate.

- (g) Rotate the record bumper lever through its 180-degree arc several times and a ¾-inch circle will be inscribed on the top plate. Turn the record bumper lever half way between its two end positions and mark the two places on the circle that are in line with holes "a" and "c." Use a 3-32-inch drill and drill at these two points two countersunk holes about ¼ of the way through the top plate. These two holes serve as stop positions for the adjustable record bumper.

4. Connect Switch to Solenoid Circuit:

- (a) Remove the black and brown leads from the right hand side of the solenoid and connect them to one of the switch leads. Connect the other switch lead to the solenoid terminal thus left vacant. This permits the operator (by turning the record bumper to the right) to disconnect the solenoid from the circuit, so that the record-change mechanism will not function while a 12-inch record is being played.

5. Replace the Record-Change Mechanism in the Cabinet

BRUNSWICK RADIO CORP.

MODEL 42
AC-DC

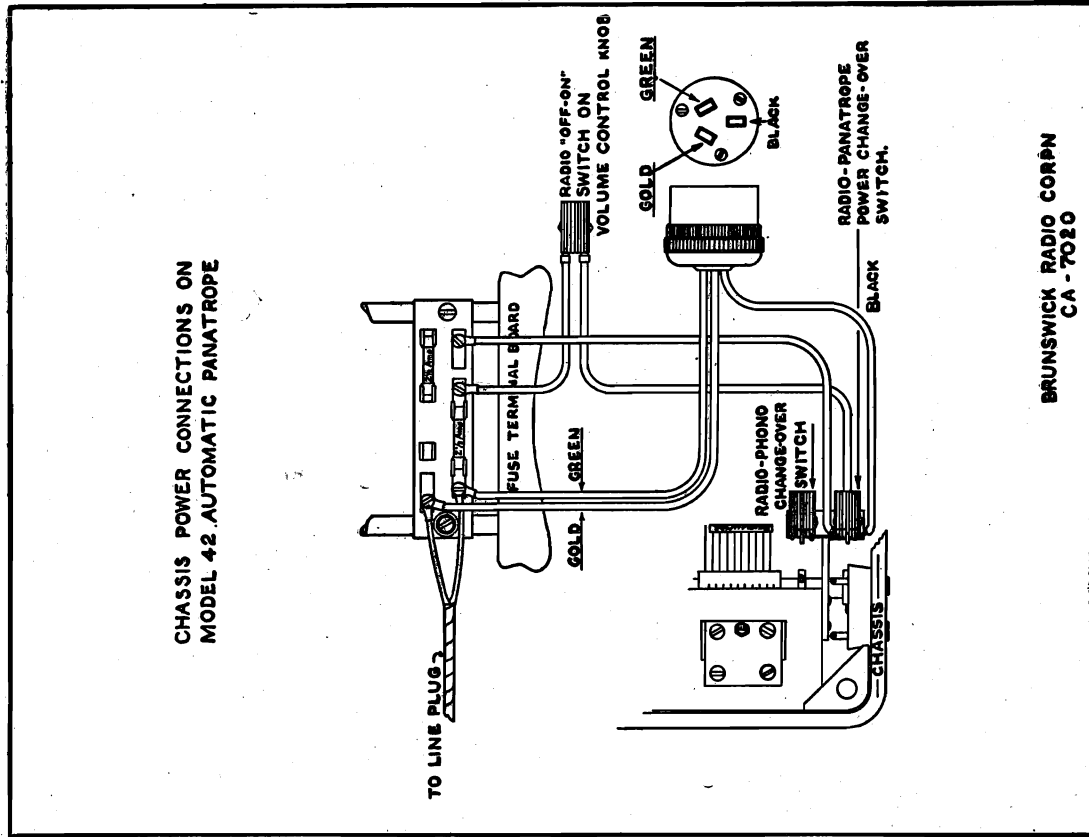

Figure 7

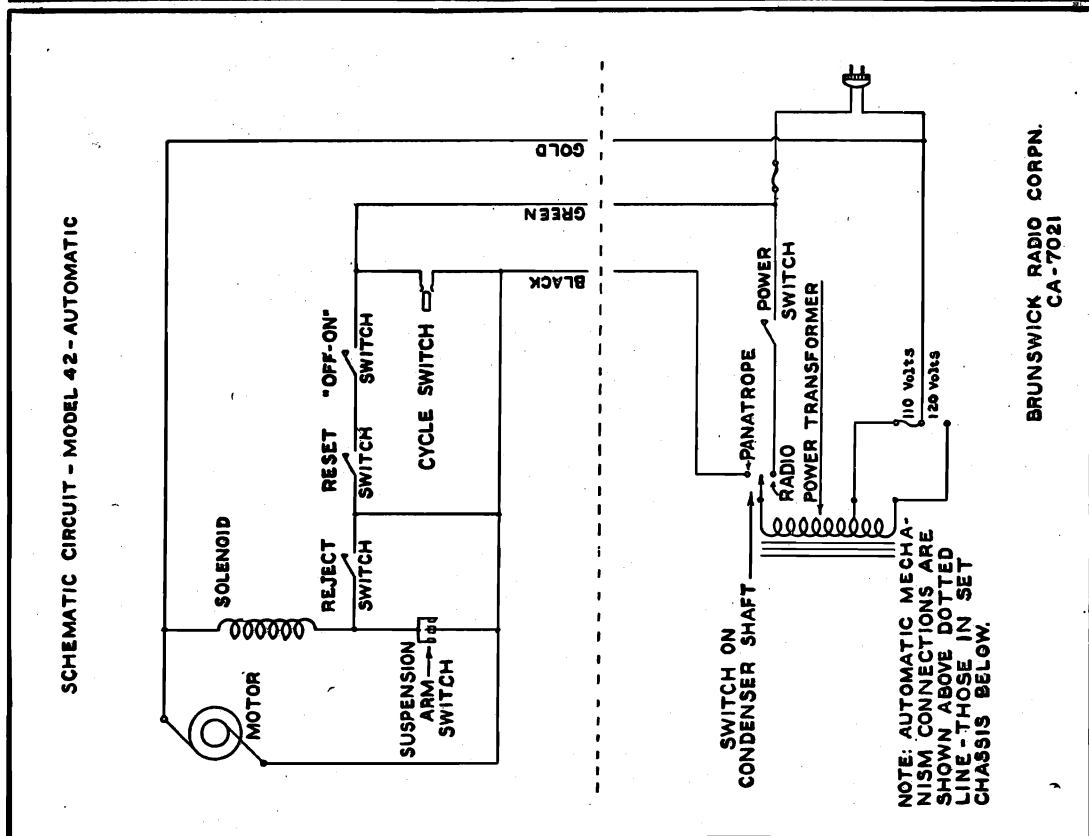

Figure 6

MODEL 42
AC-DC

BRUNSWICK RADIO CORP.

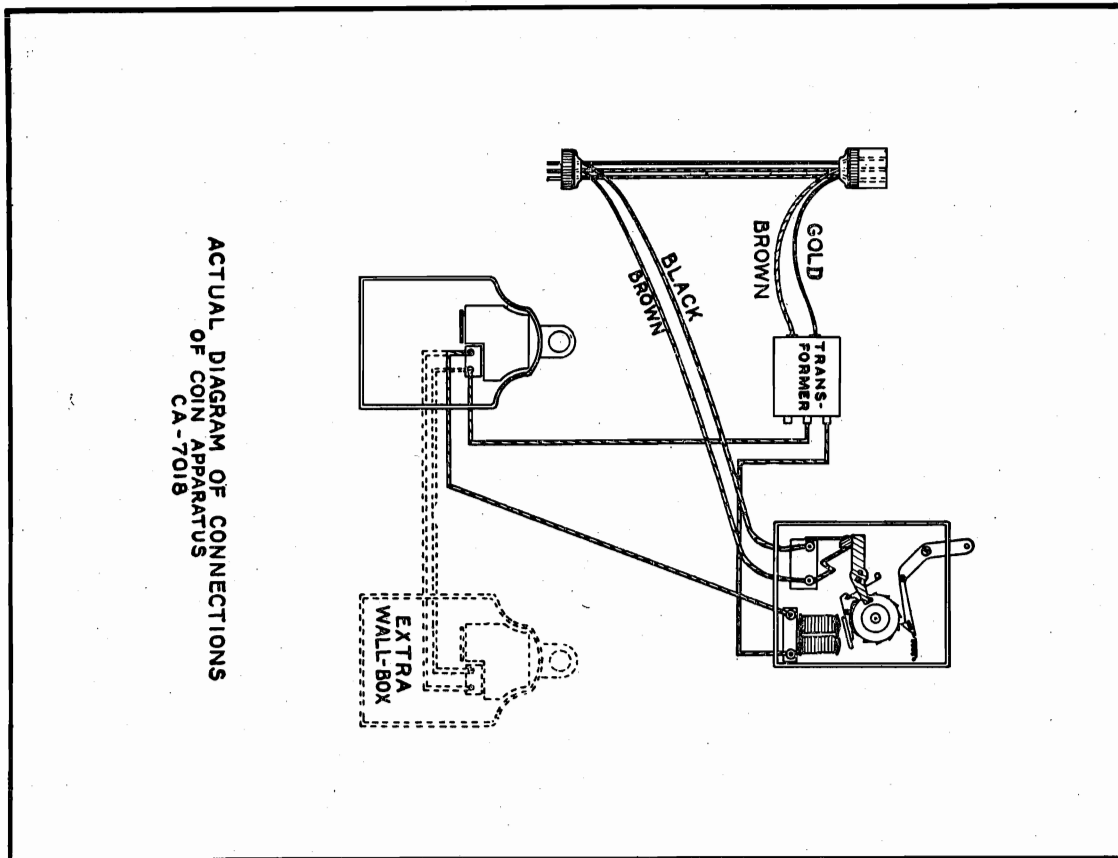

Figure 8

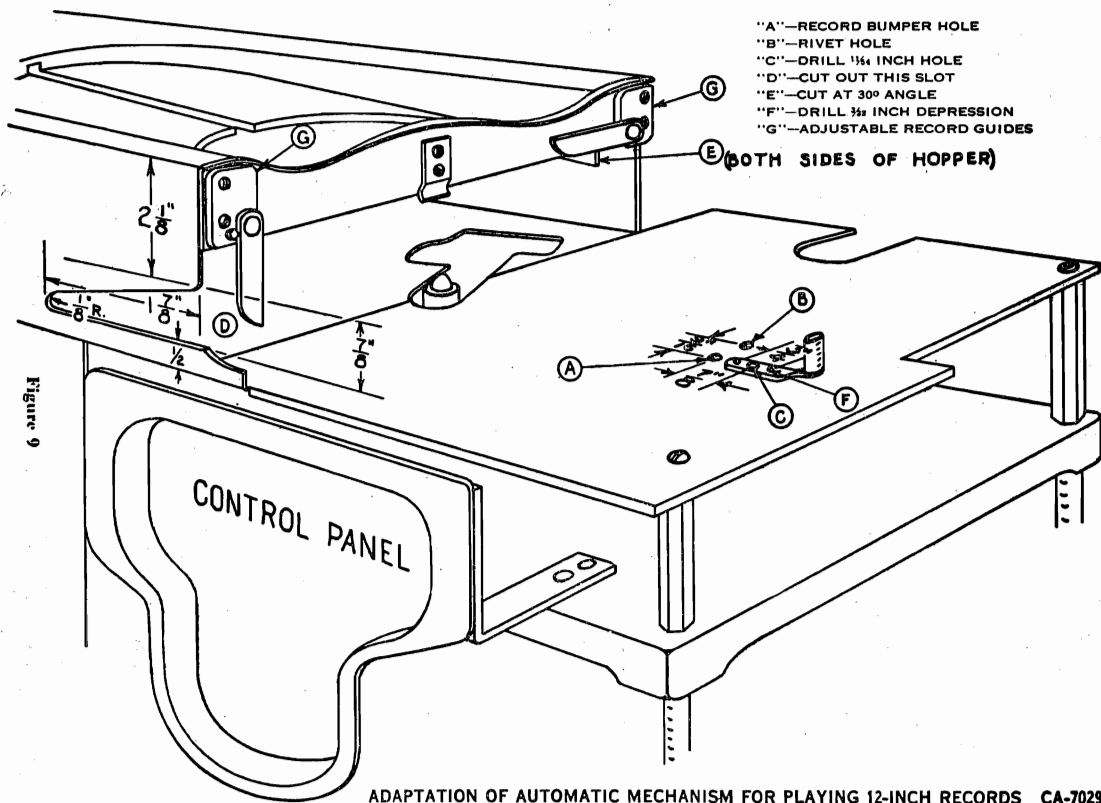

Figure 9

MODEL 3 NCS, 5 NCS
Alignment Data

BRUNSWICK RADIO CORP.

Service Operations on X-1102 and X-1103 Chassis.

A. Adjustment of R. F. Compensating Condenser.

If it is definitely known that no other defect exists in the set, antenna or ground and if the receiver is insensitive, distorts or oscillates over any or all portions of the dial then the R. F. compensating condenser should be adjusted as follows:

- (a) Tune in a long wavelength station to maximum volume, or use special test oscillator at 600 K. C.
- (b) Place non-metallic screw driver in slot of compensating condenser (located beneath panel on right side, see Print CA-6039) and turn screw in a clockwise direction until the receiver goes into oscillation. Then turn screw in opposite direction until set goes out of oscillation, and will not whistle, squeal or howl on local stations. This is the correct position of the compensating condenser.

B. Adjustment of Oscillator Trimming Condenser.

If after above adjustment explained in paragraph "A" the set is still insensitive and distorts the signal, proceed to adjust the oscillator trimming condensers in the following manner:

Material needed: Special radio frequency oscillator equipped with milliammeter, non-metallic screw driver and necessary leads.

- (a) Place special oscillator near receiver and secure the transfer of R.F. energy by twisting output lead from oscillator around blue antenna lead of receiver. The receiver ground connection should be connected to ground. In order that the milliammeter on oscillator panel will function as a tube voltmeter it is necessary to place this meter in series with the plate lead of the second detector tube. This is accomplished by removing the red wire from the terminal strip of the Socket Power Unit and connecting the resonance meter in series with this lead and the terminal from which it was removed. So that the current drawn by the power tube shall not flow through the resonance meter remove the red wire from the terminal strip of the Rectox unit and connect a jumper wire from the terminal left vacant to the terminal on the SPU which is now connected to the resonance meter. Turn volume control to minimum on receiver. Turn receiver on, then turn oscillator on and watch needle on resonance meter. If needle goes off scale to the left, reverse meter connections. Adjust oscillator for 1400 kilocycle operation and tune receiver to secure maximum deflection on resonance meter, turning the volume control up just far enough during tuning operation to keep needle at about three-fourths full scale deflection.
- (b) Adjust trimming condenser under 2nd detector tube (condenser No. 1 in Print CA-6039) with insulated screw driver, until maximum deflection is obtained on milliammeter.
- (c) Tune oscillator to 600 kilocycles and adjust trimming condenser No. 2 (to be found under oscillator tube) to maximum deflection on milliammeter.
- (d) Now re-adjust at 1400 kilocycles as in paragraph "B."

Oscillator circuit is now adjusted to give 180 kilocycles beat note over entire tuning range.

C. Part 1—Adjustment and Neutralization of I. F. Transformer.

This operation is only to be attempted when Technician is sure that the lack of sensitivity or oscillation is not due to some other fault or when it is definitely known that one of the transformers is burnt out, shorted or grounded. To test the I. F. transformers, use ohmmeter, resistance bridge or voltmeter, with milliammeter, and Ohms' law, i.e., resistance is equal to the voltage divided by the current in amperes. Primary resistance should be 20 ohms, secondary 100 ohms overall or 50 ohms from grid to center tap

MODEL RPA-5
Used in P-3

BRUNSWICK RADIO CORPORATION

R.P.A.-5.
(USED IN P-3)

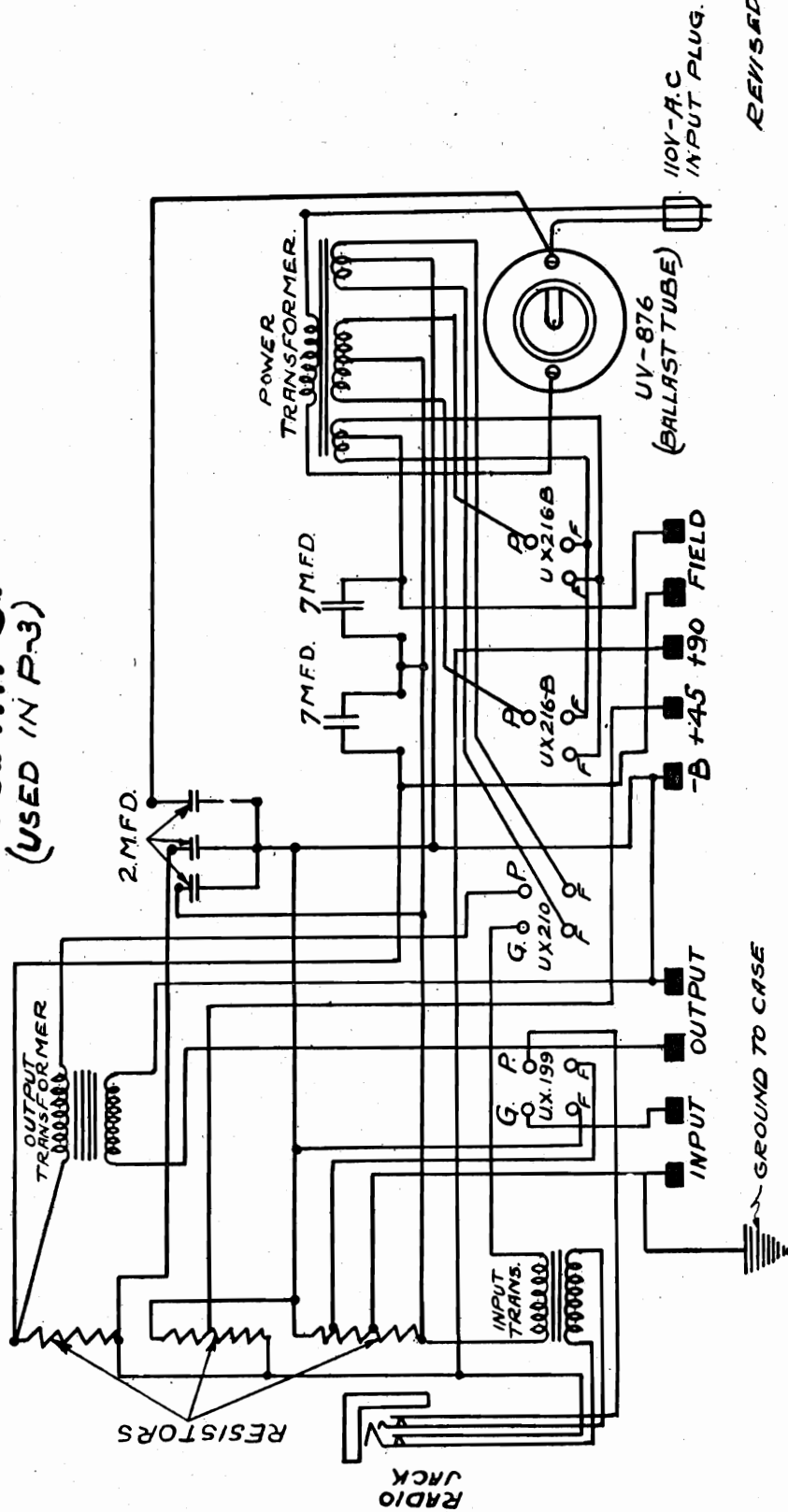

REVISED 3-10-26.

BULOVA WATCH COMPANY

MODEL M-501

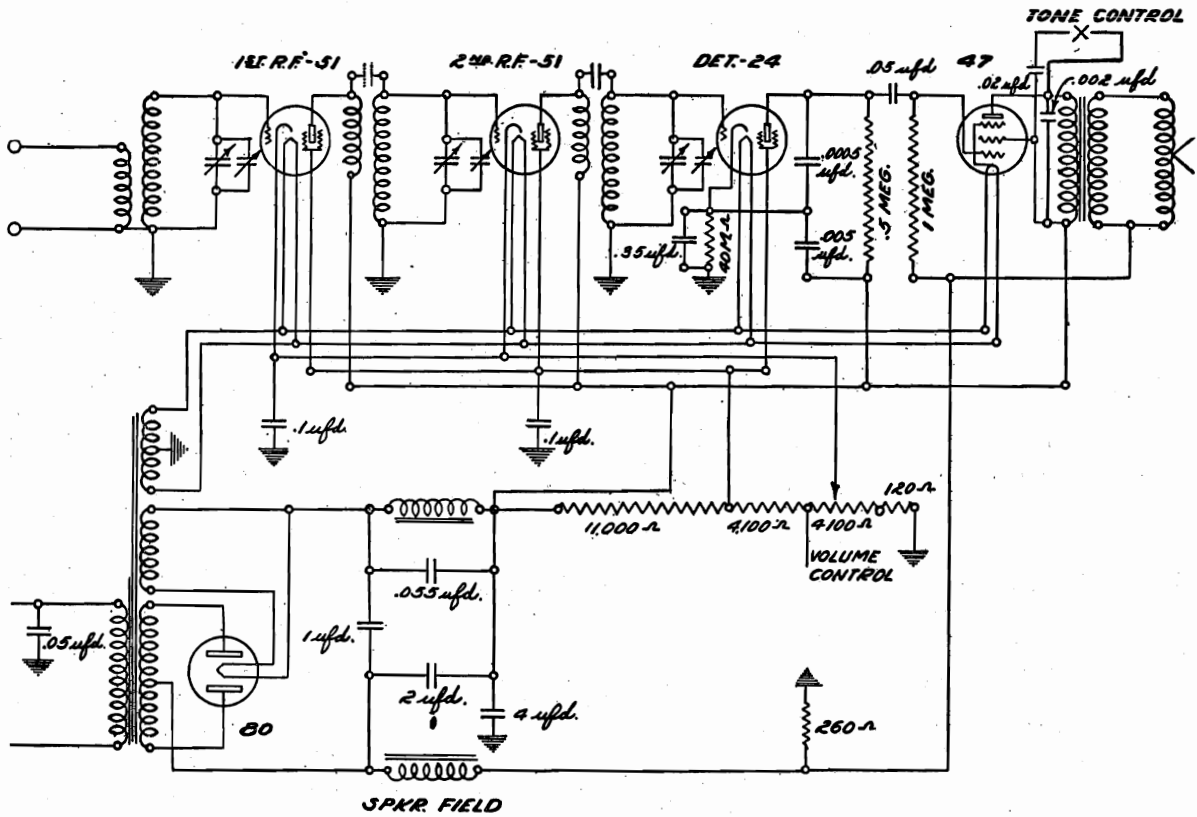

CONTINUITY TEST TABLES

(Using 10-volt scale 1,000 ohms per volt: meter with 6-volt battery)

Circuit Tested	From	To	Reading	Your Reading
Ant. coil pri.	Ant. post.	Ground	6.	
Ant. coil sec.	Grid 1st tube	Ground	6.	
1st R. F. Plate ckt.	Plate of tube	Brown lead of filter pack	6.	
1st R. F. Screen ckt.	Screen prong	Center lead Voltage divider	6.	
1st R. F. Cathode ckt.	Cath. prong	Center tap Volume Control "ON"	6.	
2nd R. F. Grid ckt.	Grid Clip	Ground	6.	
2nd R. F. Plate ckt.	Plate prong	Brown lead of filter pack	6.	
2nd R. F. Screen ckt.	Screen prong	Center tap Voltage divider	6.	
2nd R. F. Cathode ckt.	Cathode prong	Center tap Volume Control "ON"	6.	
Det. Grid ckt.	Grid Clip	Ground	6.	
Det. Plate ckt.	Plate prong	Brown lead of filter pack	6.	
Det. Screen ckt.	Screen prong	Center Voltage divider	6.	
Det. Cathode ckt.	Cathode prong	Ground	1:4	
P. Z. cont. grid.	Grid prong	Sec output trans. black lead.	(slight deflection)	
P. Z. space chg. grid ckt.	S. C. Grid Prong	Brown lead of filter pack	6.	
P. Z. Plate ckt.	Plate prong	Brown lead of filter pack	5.7	
Output Sec.	One side	Other side	5.9	
Pri Power Trans.	Across A. C. Plug	Switch on	5.9	
Hi volts Sec.	Across 280 plate prongs		5.6	
Speaker field	Red wire	Green Wire	5.4	
Speaker voice coil	Green wire	Black	6.	
Filter Choke	Across red leads		5.6	
Voltage divider	Ground	Brown lead of filter pack	2.2	

RESISTANCE TABLE

(Using 10-volt range meter 1,000 ohms per volt and 6-volt battery)

Item	Color Code*	From	To	Reading	Your Resistance in Ohms
Det. Cath. Resistor	Yel., Blk., Or.	Det. Cath.	Gnd.	1.3	40,000
Pent. Grid Resistor	Br. Blk., Green	Pent Grid	Spkr. Field	Slight Deflection	1,000,000
Wire-Wound	Black	Voice Coil, Black	Gnd.	5.9	260
Voltage Divider, Short End	Black	Volume Cont. Green Lead	S. G. Ckt.	4.2	4,100
Voltage Divider, Long End	Black	Plate	S. G. Ckt.	3.	11,000
Det. Plate Resistor	Gr., Blk., Yellow	Det. Plate	Pent. Space Chg. Grid.	.1	500,000
Vol. Control "on"		Gnd.	R. F. Cathode	4.2	4,100

*Color code: read body color first, tip second and dot last.

MODEL M-501

BULOVA WATCH COMPANY

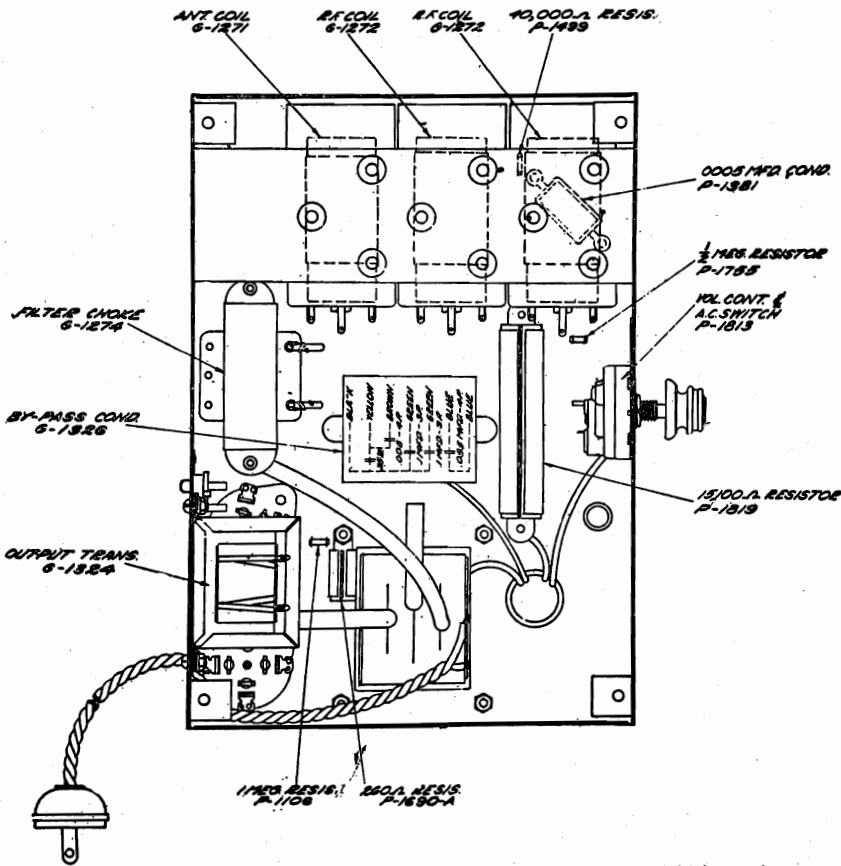
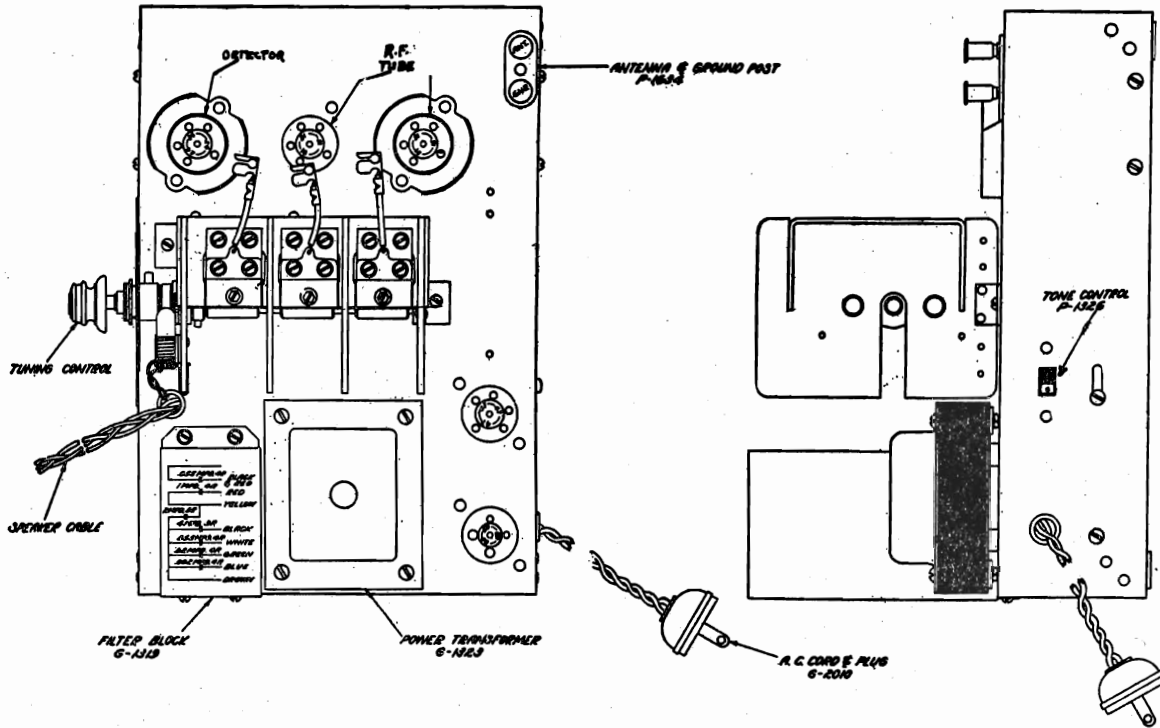

VOLTAGE ANALYSIS
 READINGS TAKEN WITH WESTON MODEL 565 ANALYZER

No.	Stage	Type Tube	Fil. Volts	Plate Volts	Cont. Grid Volts	Cath. Volts	S. G. Volts	I _p Normal
1	1st R.F.	C. L. 51	2.1	225	2.1	2	75	5
2	2nd R. F.	C. L. 51	2.1	230	2.2	2	75	4.5
3	Det.	C. L. 24	2.1	160*	7	7.5	75	02
4	Output	C. L. 47	2.1	215	5*	0	225	26.5
5	Rect.	C. L. 80	4.8	280				†30

*Reading dependent upon resistance of meter.

†Reading taken for one anode only; 60 milliamperes would be about correct.

Volume control position full. Line voltage 115—60 cycle.

BULOVA WATCH COMPANY

MODEL M-701
MODEL G-781

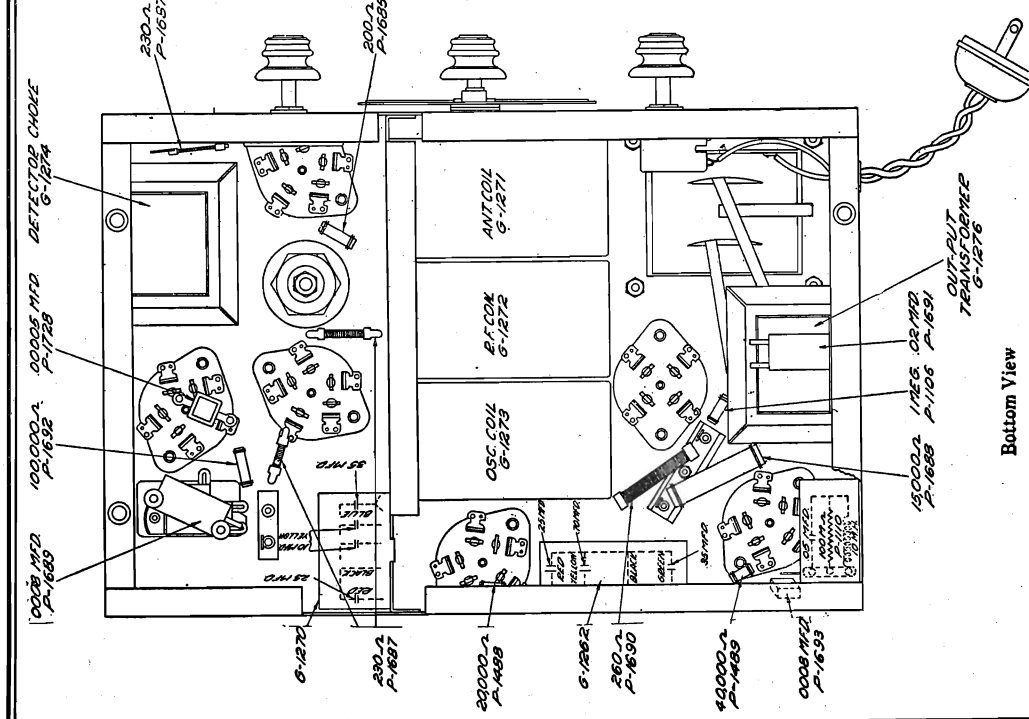
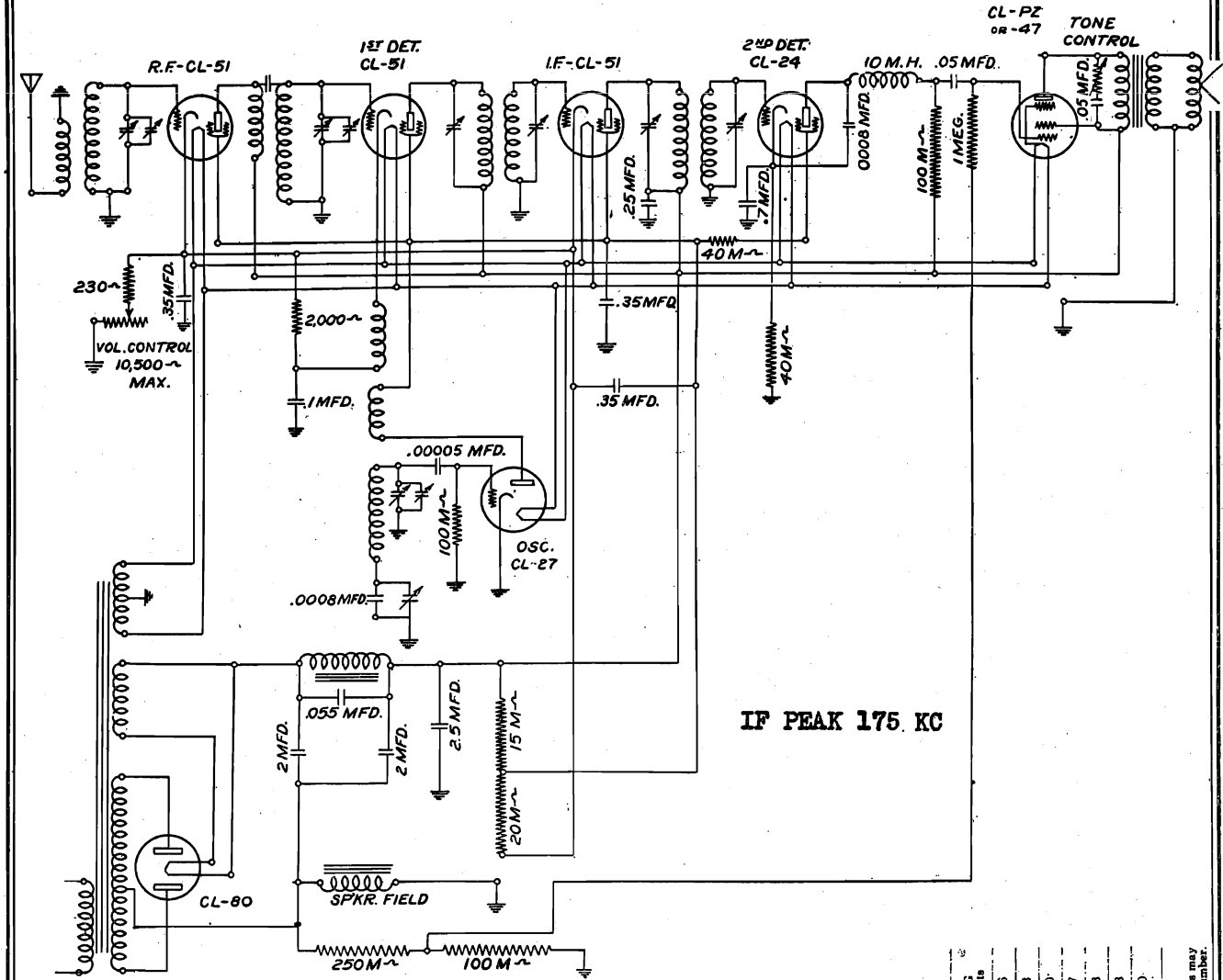

Bottom View

No.	Stage	Type Tube	A Volts	B Volts	Cont. Grid Volts	Cath. Volts	Ip' Norm.	SG Volts
1	r. l.	CL-51	2.2	233	3	3	5	66
2	1st Det.	CL-51	2.2	233	7	7	2.3	73
3	Osc.	CL-27	2.2	80	0	0	4	0
4	I.F.	CL-51	2.2	233	3	3	5	77
5	2nd det.	CL-24	2.2	162	6.2	7.2	5	.73
6	Output	CL-PZ	2.2	228	15	0	27	233
7	Rect.	CL-80	4.8	300	0	0	50	0

Volume control position Full Link Voltage 115

Note: Since resistances tolerances in the sets are plus or minus 10%, and tubes may vary over 20%, your readings may disagree with the above by plus or minus 30%. CL-PZ is also known as CL-47, the latter being the final type number.

**MODEL M-701
MODEL G-781
Automatic Clock
Control**

BULOVA WATCH COMPANY

(Using 10 volt range meter 1000 ohms per volt and 6 volt battery)

Item Tested	Description Color-Code	From	To	Resds	Your Reading	Ohms Resistance
r. f. grid bias resist.	Black Strap type Wire wound	r. f. cath. prong	Vol. cont. ungrounded terminal	5.9		230
Volume control	Variable at max. resistance	Test between its two terminals (connected)		3.2		Max. 10,500
1st det. grid bias resist.	Red Black tip	r. f. cath. prong	Other end of resist.	5.1		2,000
1st det. screen grid volts resist.	Black Strap type Wire wound	1st det. screen grid prong	Other end of resist.	5.9		230
1st det. plate resist.	Black Strap type Wire wound	Solder lug on Electrolytic cond.	B plus term. of 1st i. f. trans.	5.9		230
Oscillator grid-resist.	Brown Yellow spot Black tip	Oscillator grid prong	Ground	0.6		43,000
1. f. and r. f. cathode-bias resist.	Red Orange spot Black tip	1. f. cath. prong	1. f. screen grid prong	2.3		20,000
1. f. and det. screen grid volts resist.	Brown Orange spot Green tip	1. f. screen grid prong	Solder lug on electrolytic cond.	2.7		15,000
2nd det. grid-bias resist.	Yellow Orange spot Black tip	2nd det. cath. prong	Ground	1.3		40,000
2nd det. plate resist.	Inside-3rd term. det. r. f. filter assem.	Test between solder lugs on det. r. f. filter assem. with red wires attached		0.6		100,000 in series with 10m.h. choke
Pentode grid-resist.	Brown Green spot Black tip	Pentode Grid prong	Dummy solder lug off output trans. sec.	0.5		1 Meg.
Pentode grid-bias	Wire wound Strap type	Dummy solder lug off-output trans. sec.	Ground	5.9		260

Resistance Table

AUTOMATIC CLOCK CONTROL WIRING DIAGRAM

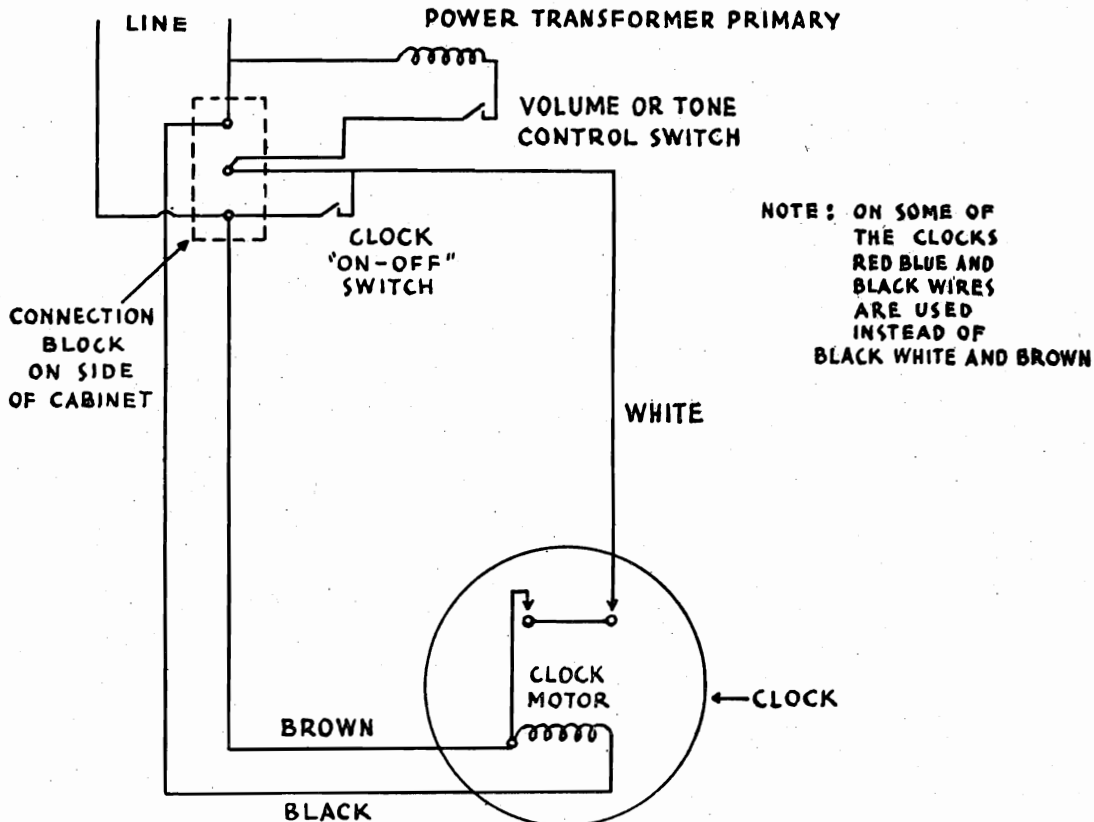

BULOVA WATCH COMPANY

MODEL C-751
Schematic

PEAK FREQUENCY - 175 K.C.

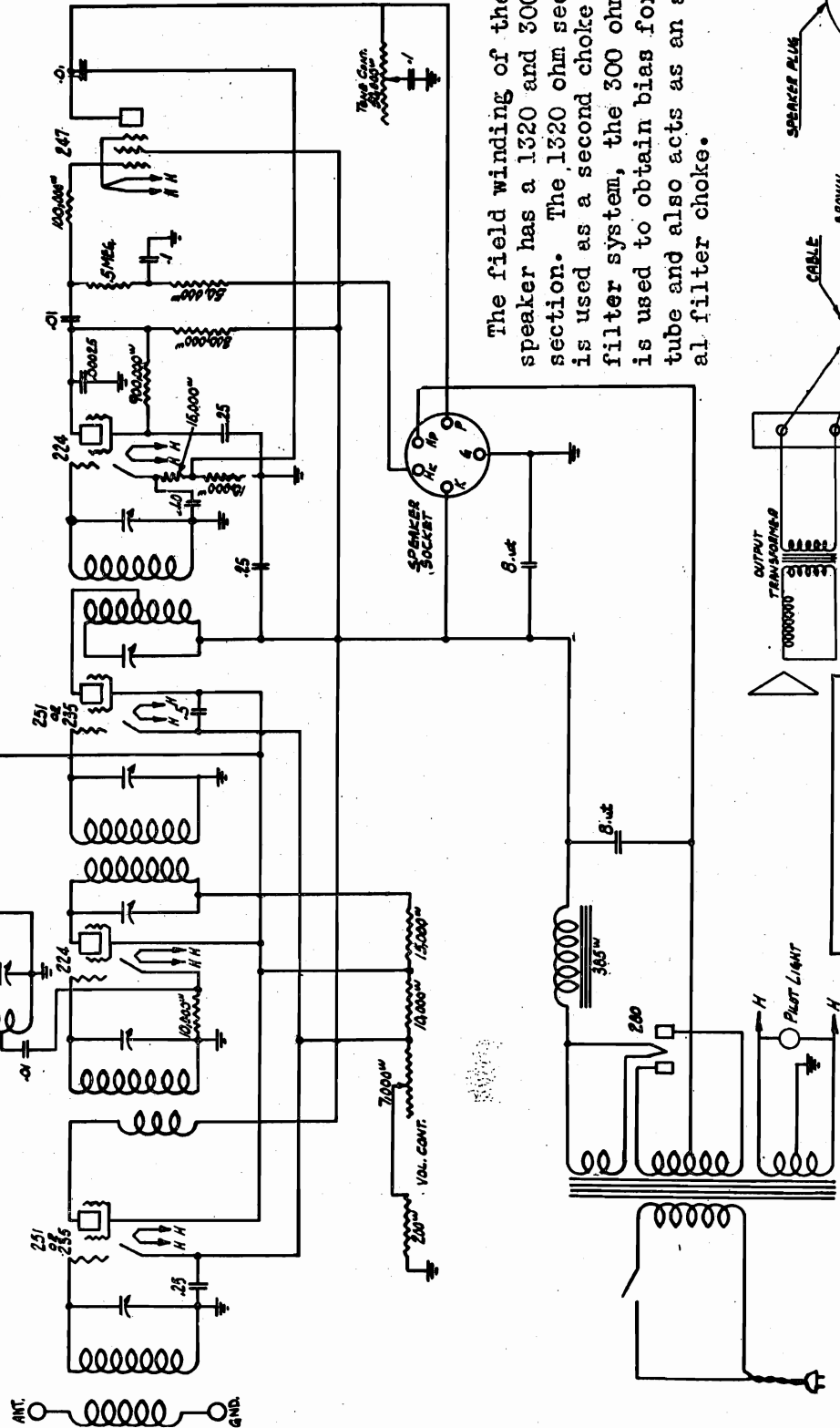

The field winding of the dynamic speaker has a 1320 and 300 ohm section. The 1320 ohm section is used as a second choke in the filter system, the 300 ohm section is used to obtain bias for the -47 tube and also acts as an additional filter choke.

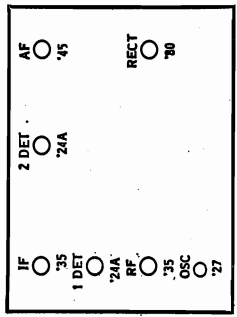
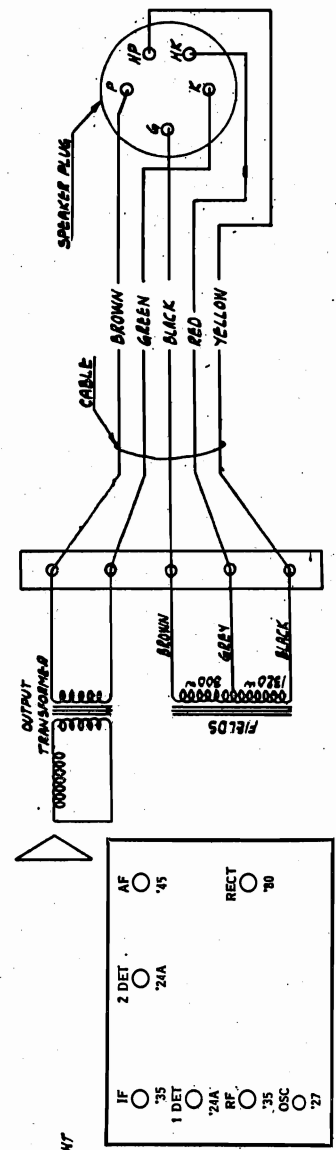

MODEL C-751
Voltage and
Service Notes

BULOVA WATCH COMPANY

BULOVA CLOCK RADIO MODEL C-751 .

VOLTAGE TABLE

Never check voltages until all tubes are fully warmed up to proper operating condition. The voltage table given below is taken at 115 volts line with a Model 547 Weston set checker. It must be remembered that the voltage readings taken vary directly as the line voltage and also with the accuracy of the meters used. A variation of 10% plus or minus is permissible.

115 V. Line Volume Control Full On

TUBE VOLTAGES		Filament	B	C	NORMAL	Screen
Type of Tube	Position of Tube	Volts	Volts	Volts	PLATE M.A.	Volts
227	Oscillator	2.4	62.5		4.75	
235	Radio Frequency	2.4	240	2.15	2.75	27
224	1st Detector	2.4	230	4.35	.5	65
235	Intermediate	2.4	237	2.15	2.75	72
224	2nd Detector	2.4	100*	2.1*	2.5	35*
247	Pentode	2.4	250	16.5**	32.5	250
280	Rectifier	4.95			27 ea. plate	

*These readings are only comparative and are not true voltages applied. The volt meter, when the readings are taken at these points, is in series with a very high resistance.

** To read the 247 bias, read between H.K. speaker socket and ground.

INTERMEDIATE TRANSFORMERS:

The intermediate transformers are of the band pass type and of exceptionally high uniform gain. They are tuned to 175 kilocycles. The intermediate frequency trimmers are mounted on an isolantite base, preventing the transformer from becoming detuned due to the trimmer condensers absorbing moisture or warping. For this reason it should rarely, if ever, be necessary to re-track the intermediate frequency trimmers. In the event that it should be advisable to re-align the intermediate frequency coils, it is absolutely essential that a 175 kilocycle oscillator and an output measuring device be used.

ALIGNMENT OF RECEIVER:

Because of the construction and thorough impregnation of the intermediate coils, the intermediate stages should rarely need re-tracking. Only when an intermediate coil has become defective due either to an open or burned out winding, should it be necessary to re-adjust the intermediate trimmers. Should this occur, it is necessary that an oscillator be used and the intermediate trimmers be adjusted at 175 kilocycles. To align the intermediate stages, connect the high side of the oscillator output to the grid circuit of the first detector, which is done by disconnecting the grid cap of the 224 first detector and connecting the high side of the test oscillator to the control grid of this tube. The ground side of the test oscillator should be connected to the ground post on the chassis. Set the oscillator at 175 kilocycles and adjust the output of the oscillator so that a convenient reading is obtained on the output meter. Be sure that the output from the oscillator is not so large that it will overload the second detector. If during the alignment the meter goes off scale, reduce the output of the test oscillator or adjust the receiver volume control.

The trimmers of the intermediate coils are accessible through the small holes in the top of the intermediate shield can. There are two trimmers to each intermediate coil. Align the grid trimmer of the first intermediate coil. After a maximum reading is obtained by adjusting the grid trimmer on the first intermediate, adjust the primary for maximum reading and then re-check the grid side to make certain the alignment of the secondary has not been changed by the adjustment of the primary. The same procedure is followed in aligning the second intermediate coils. After both intermediate coils are properly aligned the adjustment of the intermediate stage is complete and they should not be further disturbed.

Replace the grid cap on the first detector and connect the oscillator output leads to the antenna and ground posts of the receiver and set the oscillator at 1435 kilocycles. Then tune the receiver to 1435 kilocycles on the dial. It is important that the receiver be tuned to this point. If the receiver is out of the cabinet it will be necessary to use some temporary indicator so that the position 1435 kilocycles on the dial may be accurately located. (This indicator should be set so that when the variable condensers are at the maximum capacity stop the indicator points to the last line on the dial at the low frequency end.) Then track the variable condensers by adjusting the trimmer condensers in the following order: Oscillator, antenna and radio frequency - (reading from the front of the receiver toward the back, the variable condenser sections are: Oscillator, antenna and radio frequency). After the variable condensers have been properly tracked at 1435 kilocycles, adjust the oscillator to 1295 kilocycles. Tune the receiver to this frequency. Check alignment of the condensers at this point by bending the end plate of the rotors in and out, noting the change in reading on the output meter. If when the plates are bent in the reading is increased, it is an indication that that particular section requires more capacity and the end plate should be permanently bent in at this point; or, if when the end plate is bent away, the reading is increased, the end plate should be bent away permanently, as it is an indication that that particular section requires less capacity at that particular point. The variable condensers should be checked in this manner at 1295, 880, 650 and 550 kilocycles. These points have been chosen so as to take advantage of the slots in the end plates of the variable condensers. This procedure of bending plates should rarely be necessary on the oscillator section, as the plates of the oscillator section are especially designed to properly track over the broadcast spectrum, providing the antenna and radio frequency stages are correctly aligned.

CAPEHART CORPORATION

RECORD CHANGER
Model 10-12-C

ASSEMBLY OF MOTOR TO BASE PLATE

The motor is attached to the base plate by three bolts, and mounted on rubber cushions. The brace that is over the turntable spindle and bolted to the base plate serves as an excellent gauge for aligning the motor in the center.

When removing the two screws that hold the turntable locating plate over the turntable spindle, preparatory to operating the instrument, be sure that the locating plate lines up with the holes that the screws are just removed from.

If the motor has become shifted in transit there will be a tendency for the holes in the locating plate and base plate to not perfectly line up.

In this case it is necessary to slightly loosen the three bolts holding the motor to the base plate and shift the motor to such position that the holes in the brace and the base plate align perfectly, and while the brace is still in place, tighten the suspension bolts to hold the motor in that particular position. The brace must then be removed before the turntable is mounted on the shaft.

In placing the turntable on the shaft, be certain that the rubber driving washer is in proper place with clips over the spindle pin.

After the turntable is put on the shaft, force it down by hand to be sure that the rubber washer and turntable are making perfect contact.

To level the turntable, place a straight edge across the turntable and adjust the three suspension bolts holding the motor to the base plate until the same distance is obtained from the bottom edge of the straight edge to the base plate near the three points where the suspension bolts are located.

This measurement should be approximately 11/16". This adjustment must be made so that there is no free movement of the motor by either of the suspension bolts being too loose.

TOE ARM ADJUSTMENT FOR TEN INCH AND TWELVE INCH RECORDS

Pickup change lever No. 5509 is for changing the instrument from 10 inch to 12 inch record operation and vice versa.

The lever changes the position of the pickup return lever in such a manner that the needle is let down for the 10 inch or the 12 inch record, as desired.

To adjust for playing 10 inch records, loosen the forward lever stop No. 5526 and hold the lever in such a position that the needle will come down on a 10 inch record exactly 4-11/16" from the edge of the center pin. (A scale should be placed on the record with the end of the scale against the centering pin in such a position that the needle point will come down on the scale at the 4-11/16" inch position.)

When the proper location of lever No. 5509 is ascertained, then the front stop may be set snug against this lever and the screw tightened, which will allow the lever to always be thrown over to that exact position when desiring to play 10 inch records.

To adjust for playing 12 inch records, loosen the back lever stop No. 5527 and hold the lever in such position that the needle will come down exactly 5-11/16" from the edge of the centering pin. (A scale should be placed on the record with the end of the scale against the centering pin in such position that the needle point will come down on the scale at the 5-11/16" position.)

In the event you are unable to properly adjust for either 10 inch or 12 inch records by the above method, make the adjustment as nearly correct as possible then refer to instructions on Page 6 and check Tone Arm Bracket Lever adjustment making certain the adjustment is correct.

Then loosen the lock nut holding the adjustment screw on the tone arm return lever No. CA5687 and turn the adjusting screw either in or out, as the occasion requires, to bring the needle to the proper location for the size record you are unable to adjust for by the lever stop method. It will then be necessary to readjust the lever stop which was originally set in position for the other size record.

The lever stop screws must be set tight, so the lever stops will not be jarred out of position as the lever is thrown from one position to the other.

ADJUSTMENT OF PICKUP WEIGHT

Make this adjustment while music is being played, and only one record is on the turntable. With a delicate pair of scales, having a range of 0 to 12 ounces, catch the needle screw and lift the pickup from the record until the audio quality breaks, at which time a reading of 5 1/4 to 6 ounces should be shown on the scales. Raising or lowering the spring support No. 5575 which is affixed to the tone arm lifting rod No. 5553 adjusts the weight of the pickup.

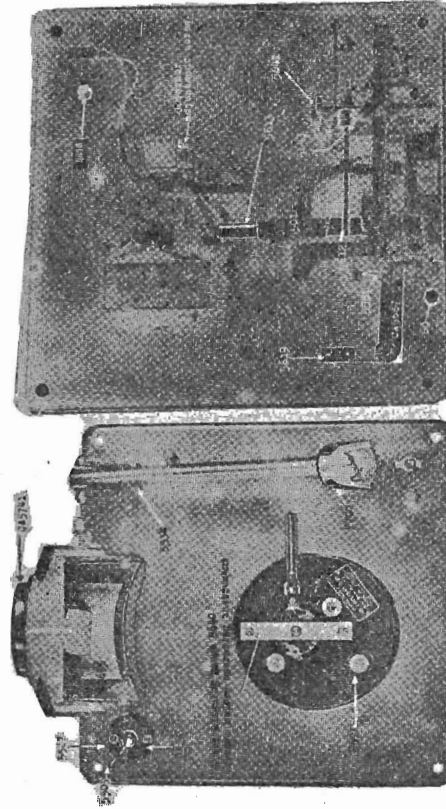

Fig. 2

- 5419 Economic Spring Arm
- 5441 Short Crown Spring Arm
- 5442 Volume Control
- 5443 Volume Control
- 5444 Volume Control
- 5445 Volume Control
- 5446 Volume Control
- 5447 Tone Arm Return Lever & Fork Arm
- 5448 Tone Arm Return Lever
- 5449 Drive Head
- 5450 Drive Head
- 5451 Drive Head
- 5452 Drive Head
- 5453 Drive Head



- 5454 Governor Handle
- 5455 Governor Lever
- 5456 Governor Lever
- 5457 Governor Lever
- 5458 Governor Lever
- 5459 Governor Lever
- 5460 Governor Lever
- 5461 Governor Lever
- 5462 Governor Lever
- 5463 Governor Lever
- 5464 Governor Lever
- 5465 Governor Lever
- 5466 Governor Lever
- 5467 Governor Lever
- 5468 Governor Lever
- 5469 Governor Lever
- 5470 Governor Lever
- 5471 Governor Lever
- 5472 Governor Lever
- 5473 Governor Lever
- 5474 Governor Lever
- 5475 Governor Lever
- 5476 Governor Lever
- 5477 Governor Lever
- 5478 Governor Lever
- 5479 Governor Lever
- 5480 Governor Lever
- 5481 Governor Lever
- 5482 Governor Lever
- 5483 Governor Lever
- 5484 Governor Lever
- 5485 Governor Lever
- 5486 Governor Lever
- 5487 Governor Lever
- 5488 Governor Lever
- 5489 Governor Lever
- 5490 Governor Lever
- 5491 Governor Lever
- 5492 Governor Lever
- 5493 Governor Lever
- 5494 Governor Lever
- 5495 Governor Lever
- 5496 Governor Lever
- 5497 Governor Lever
- 5498 Governor Lever
- 5499 Governor Lever
- 5500 Governor Lever
- 5501 Governor Lever
- 5502 Governor Lever
- 5503 Governor Lever
- 5504 Governor Lever
- 5505 Governor Lever
- 5506 Governor Lever
- 5507 Governor Lever
- 5508 Governor Lever
- 5509 Governor Lever
- 5510 Governor Lever
- 5511 Governor Lever
- 5512 Governor Lever
- 5513 Governor Lever
- 5514 Governor Lever
- 5515 Governor Lever
- 5516 Governor Lever
- 5517 Governor Lever
- 5518 Governor Lever
- 5519 Governor Lever
- 5520 Governor Lever
- 5521 Governor Lever
- 5522 Governor Lever
- 5523 Governor Lever
- 5524 Governor Lever
- 5525 Governor Lever
- 5526 Governor Lever
- 5527 Governor Lever
- 5528 Governor Lever
- 5529 Governor Lever
- 5530 Governor Lever
- 5531 Governor Lever
- 5532 Governor Lever
- 5533 Governor Lever
- 5534 Governor Lever
- 5535 Governor Lever
- 5536 Governor Lever
- 5537 Governor Lever
- 5538 Governor Lever
- 5539 Governor Lever
- 5540 Governor Lever
- 5541 Governor Lever
- 5542 Governor Lever
- 5543 Governor Lever
- 5544 Governor Lever
- 5545 Governor Lever
- 5546 Governor Lever
- 5547 Governor Lever
- 5548 Governor Lever
- 5549 Governor Lever
- 5550 Governor Lever
- 5551 Governor Lever
- 5552 Governor Lever
- 5553 Governor Lever
- 5554 Governor Lever
- 5555 Governor Lever
- 5556 Governor Lever
- 5557 Governor Lever
- 5558 Governor Lever
- 5559 Governor Lever
- 5560 Governor Lever
- 5561 Governor Lever
- 5562 Governor Lever
- 5563 Governor Lever
- 5564 Governor Lever
- 5565 Governor Lever
- 5566 Governor Lever
- 5567 Governor Lever
- 5568 Governor Lever
- 5569 Governor Lever
- 5570 Governor Lever
- 5571 Governor Lever
- 5572 Governor Lever
- 5573 Governor Lever
- 5574 Governor Lever
- 5575 Governor Lever
- 5576 Governor Lever
- 5577 Governor Lever
- 5578 Governor Lever
- 5579 Governor Lever
- 5580 Governor Lever
- 5581 Governor Lever
- 5582 Governor Lever
- 5583 Governor Lever
- 5584 Governor Lever
- 5585 Governor Lever
- 5586 Governor Lever
- 5587 Governor Lever
- 5588 Governor Lever
- 5589 Governor Lever
- 5590 Governor Lever
- 5591 Governor Lever
- 5592 Governor Lever
- 5593 Governor Lever
- 5594 Governor Lever
- 5595 Governor Lever
- 5596 Governor Lever
- 5597 Governor Lever
- 5598 Governor Lever
- 5599 Governor Lever
- 5600 Governor Lever

GOVERNOR ADJUSTMENT

If the turntable speed cannot be regulated to 78 R. P. M. by the speed control lever located under the turntable, then loosen the set screw holding the governor to the governor shaft and move the governor either in or out, as the case may be, to increase or decrease the speed of the motor.

This adjustment must be made when the speed control lever under the turntable is in the center position.

To increase the speed of the turntable motor, move the governor out, and to decrease the speed of the turntable, move the governor in.

Do not, under any conditions, change the adjustment of the end thrust bearing screws. An occasional drop of oil on the governor brake will assist in maintaining a constant speed.

OVER

**MODEL 10,12-C
Service Notes**

CAPEHART CORPORATION

ASSEMBLY AND ADJUSTMENT OF OSCILLATING AND SPIRAL TRIP LEVER AND PICKUP SILENCER

To time the automatic switch so the instrument will automatically trip and change records, proceed as follows:
 First: Thoroughly acquaint yourself with the different part numbers.
 Second: Study the photographs carefully and note the relative location of the various parts.
 Third: Complete each of the following operations before going on to the next operation.

Operation No. 1.
 Turn the master cam No. 5504 until the large timing mark is exactly above the timing mark on the tone arm lifting lever No. 5761.

Operation No. 2.
 Hold the switch lever and cam assembly No. 5612 against the driven clutch No. 5616, so the radius of the cam will center against the clutch. (Be sure that cam No. 5612 is directly under the driven clutch No. 5616.)

Operation No. 3.
 Set the pickup silencer switch No. 5643 against the casting bearing so the shaft of cam No. 5612 cannot be moved further toward the automatic switch.

Operation No. 4.

Hold the tail of cam No. 5612 against the lug on the inside of the master cam No. 5504 and adjust the trip lever No. 5611 until it is 1/16" beyond the catch in the oscillating trip lever No. 5657. This adjustment is made while the tail of the cam No. 5612 is held against the outside of the lug inside the master cam No. 5504.)

Operation No. 5.

Care must be exercised to have the end play of the oscillating trip shaft just free. This is taken care of in adjusting the pickup silencer switch No. 5643, so a good contact is made on the pickup short circuiting switch WHEN THE NEEDLE IS ON THE RECORD AND THE AUTOMATIC SWITCH HAS BEEN TRIPPED.

After the pickup silencer switch No. 5643 has been set according to the above instructions, the resetting of the automatic trip should allow the contacts on the pickup silencing switch to open. If the above operations are followed out in detail, and adjustments properly made, the clutch will automatically disengage when the pin on the clutch No. 5616 has travelled approximately one-half of the distance of cam No. 5612.

At the time the pin has travelled one-half of the distance of the clutch release cam, the small timing mark on cam No. 5504 should be exactly above the timing mark on the tone arm lifting lever No. 5761.

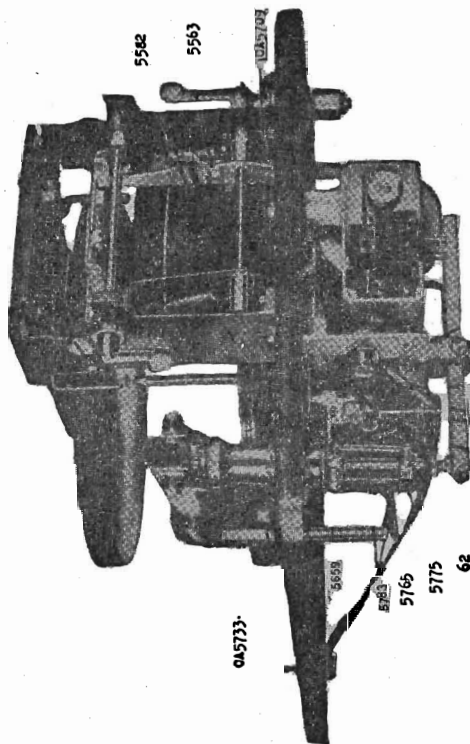

Fig. 3

- 62 1/4-28 Hex Head Screw.
- 5129 Spiral Trip Cam.
- 5783 Tone Arm Lift Rod.
- 5554 Eccentric Pin.
- 5563 Slide Finger Eccentric.
- 5582 Link Spring-Upper.
- 5583 Trip Lever Spring.
- 5611 Trip Lever & Hub Assy.
- 5618 Oscillating Trip Dog Assy.
- 5659 Tone Arm Bracket Layer & Pin Assy.
- 5657 Oscillating Trip Lever Assy.
- CA5709 Slide Finger & Shaft Assy.
- CA1531 Reject Stud Assy.
- CA1742 Switch Panel Assy.
- 5785 Tone Arm Weight Adj. Spring
- 5775 Tone Arm Spring Hook

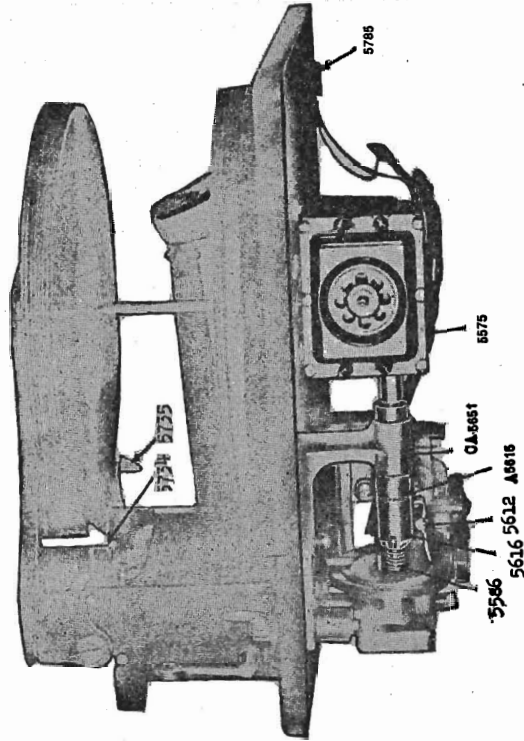

Fig. 4

- 5612 Trip Lever & Cam Assy.
- A5615 Drive Shaft Assy.
- 5615 Drive Shaft Assy.
- 5616 Driven Ratchet & Pin Assy.
- CA5651 Main Drive Assy.
- 5785 Switch Double Circuit H & H.
- 5582 Clutch Spring-Upper and cycles.
- 5575 Governor Assy.
- 5690 Governor Assy.
- 5734 Record Lock Lever & Hook Assy-Left.
- 5735 Record Lock Lever & Hook Assy-Right.

OVER

CAPEHART CORPORATION

ADJUSTMENT OF THE SPIRAL TRIP CAM

To adjust the spiral trip cam, turn the master cam No. 5504 until the small timing mark is exactly above the timing mark on the tone arm lift lever No. 5761 at which time the automatic trip can be manually reset or tripped at will.

Lay a steel scale, graduated in 64ths, flat on the record under the pickup, with the end of the scale against the turntable spindle in such position that the needle rests on the scale. By sliding the needle toward the center of the record, the spiral cam should cause the automatic trip to operate when the point of the needle is 1-49 64" from the edge of the turntable spindle.

If the automatic trip operates before the needle has come to 1-49 64" position, then the spiral cam is set too far ahead and must be moved very slightly back, while, if the needle comes closer to the turntable spindle than 1-49 64", then the spiral cam is set too far back and must be set ahead to the proper position.

Failure to properly adjust the spiral trip cam so the automatic trip operates when the needle is 1-49 64" from the edge of the turntable spindle will cause the instrument to change records before the music is finished, or to not change records automatically.

To adjust the spiral trip cam No. 5529, slightly loosen the two screws holding the cam to automatic switch lever No. 5657 and pry the cam forward or back as required to obtain the proper setting.

To test the position of the spiral cam, it is necessary to carry the pickup back to the edge of the record each time to manually reset the automatic trip.

ASSEMBLY OF TRIP BRACKET TO BASE PLATE

The automatic trip bracket No. CA 5742 is mounted to the base plate by two nickel plated bolts and lock washers.

The end that the bakelite panel is mounted on, is to be mounted toward the front of the base plate in such a manner that the bearing aligns perfectly with the bearing in the drive bracket. The final alignment can be made when the trip lever shaft No. 5612 is being installed and adjusted.

TO NE ARM BRACKET LEVER ADJUSTMENT

Set lever No. 5509 to 10 inch record operating position, and slightly loosen the clamp screw holding the bracket lever No. 5704 to the bracket under the tone arm base, and turn the bracket lever to such position that the slot, where the bracket lever clamps together around the bracket, is exactly centered on each side of the aligning notch cut in the lower rim of the bracket.

Then lay a scale, graduated in 64ths, on the turntable, placing the end of the scale against the turntable spindle in such position that when the needle is automatically let down the point of the needle will come to exactly 4-11 16" from the edge of the turntable shaft.

If the needle does not automatically come down at the 4-11 16" position refer to page 2 and make final adjustment at lever stop on lever No. 5509.

Care should be exercised to lock the tone arm return bracket lever, allowing .015 inch clearance between the cork insert and the tone arm base.

After the adjustment is properly made, tighten the clamp holding the tone arm bracket lever No. 5704 in place, which should leave ample clearance between the cork insert and the tone arm housing to allow perfect freedom of the tone arm operation.

If needle fails to feed into music groove, lift tone arm bracket lever No. 5704 tightly against tone arm housing and manually move tone arm back and forth to relieve any unevenness that might occur on the face of the cork insert.

ASSEMBLY AND ADJUSTMENT OF RECORD MAGAZINE

The record magazine pin No. 5555 must be tightened in the elongated hole in the magazine top plate No. A5736 in such a manner that the offset at the bottom of the pin extends directly away from the record support shelf.

The magazine pin must also be adjusted to such a position that exactly 4 7/8" clearance is obtained between the back center of the offset at the bottom of the magazine pin, and the extreme right and left corners of the record support shelf. This adjustment is to be made when the record magazine is in 10 inch playing position.

TO ADJUST THE RECORD SUPPORT HOOKS

First, throw lever No. 5509 to the 10 inch position, and place a 10 inch record on the magazine pin, bringing the magazine down to playing position.

The record support hooks are adjusted by bending to proper position.

The record support hooks must be kept 1/16" from the edge of the record support shelf and must be adjusted far enough back to just clear the edge of a 10 inch record, as the record is released from the record support shelf.

The record support hooks must also be low enough to clear the bottom side of the record, as it is supported on the magazine shelf.

The record support hooks should operate freely in either 10 inch or 12 inch position.

ASSEMBLY OF RECORD MAGAZINE AND STANDARD TO BASE PLATE; AND ALIGNMENT OF TURNABLE SHAFT

Mount the magazine and standard on the base plate with four bolts, tightening the bolts only tight enough to hold the complete magazine assembly in position. The magazine assembly must be so adjusted by shifting the standard on the base plate to bring the offset at the bottom end of the magazine pin exactly over the center of the point of the turntable spindle.

This adjustment cannot be made until the motor has been aligned according to the instructions on page one.

Enough clearance is allowed in the four bolt holes to take care of this adjustment.

After the adjustment is made perfect, the bolts must be securely tightened with lock washers.

ASSEMBLY AND ADJUSTMENT OF RECORD SLIDE SHELF AND FINGER

First, set the master cam No. 5504 so the lug on the cam at the side of the large timing mark comes directly under the end of the record release finger No. CA 5709.

The eccentric stud No. 5563 affixed to the main record release finger controls the adjustment of record release finger. Turn the eccentric stud No. 5563 until the record slide shelf No. 5521 is 1/64" past the front edge of record support shaft No. 5520 at which time it should be possible to obtain a slight amount of clearance between the end of the record release finger and the point of the lug on the master cam without causing the safety spring, (which is a part of this lever assembly) to give.

The two points on the record slide shelf must come to the edge of the radius on the record support shelf at the same time.

RECORD WEIGHT ADJUSTMENT

The record weight No. 5769 must be so adjusted at the bearing pivot that the lower edge of the record weight does not touch the record slide shelf while in the 10 inch position, but comes low enough to hold one record in proper position for the slide plate to unload it on the turntable.

ASSEMBLY OF DRIVE BRACKET ASSEMBLY TO BASE PLATE AND MOTOR

The drive bracket No. 5661 must be bolted to the base plate in such a manner as to align the drive shaft with motor shaft, so the coupling is free. A flexible coupling No. 5613 takes care of any minor lack of alignment between the drive shaft and the motor shaft, because of the motor hanging on rubber cushions.

OVER

COLONIAL RADIO CORP.

MODEL 33,34,35 AC
Layouts

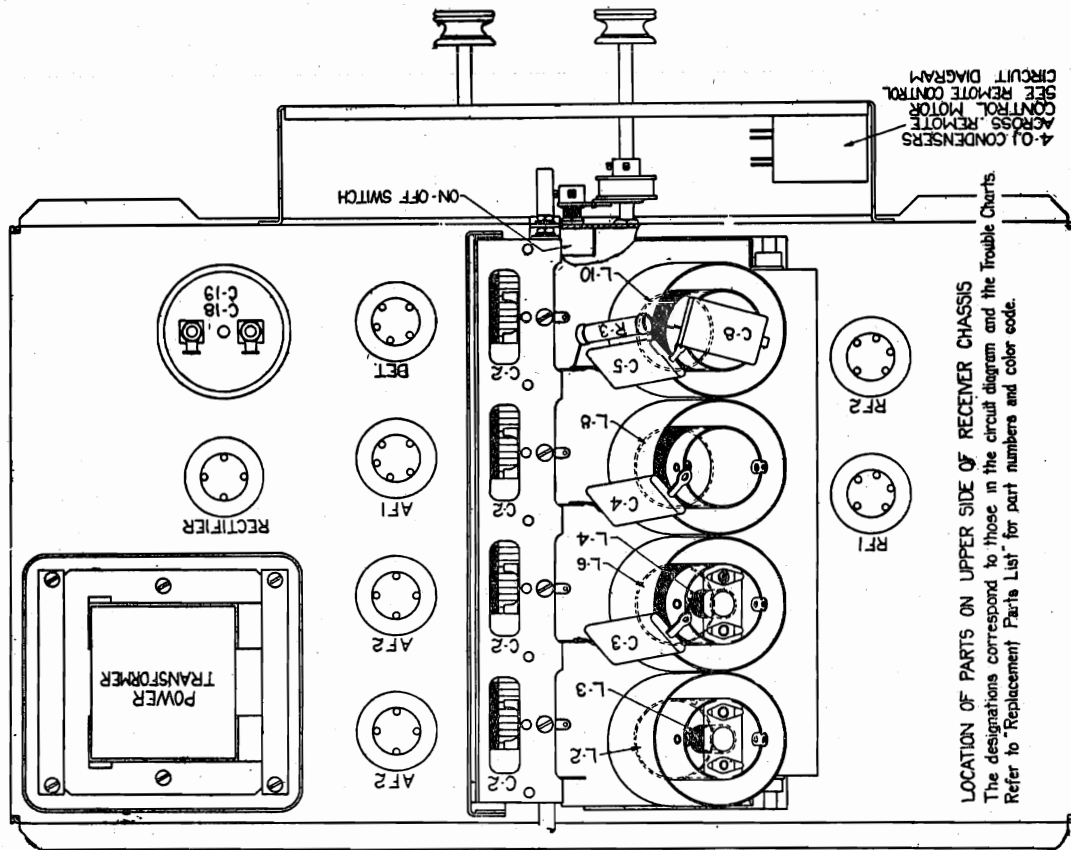

LOCATION OF PARTS ON UPPER SIDE OF RECEIVER CHASSIS
The designations correspond to those in the circuit diagram and the Trouble Charts
Refer to 'Replacement Parts List' for part numbers and color code.

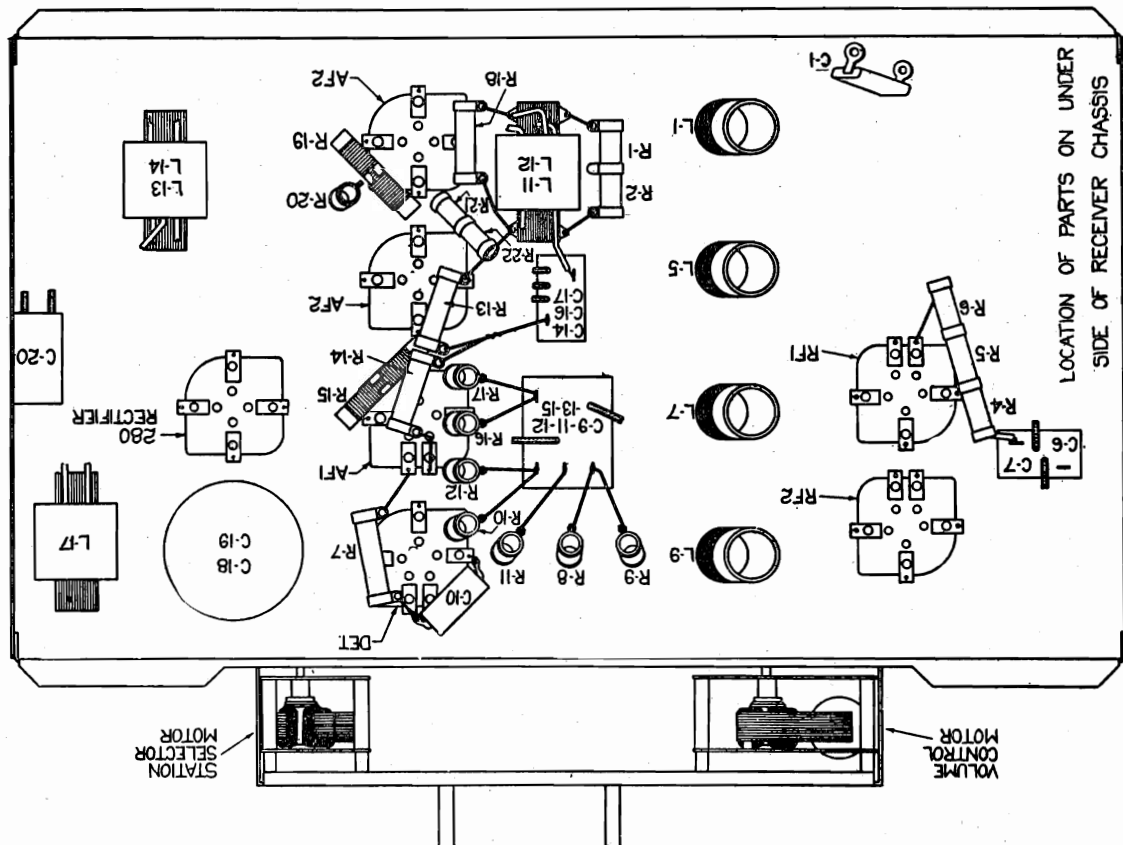

LOCATION OF PARTS ON UNDER
SIDE OF RECEIVER CHASSIS

MODEL 33, 34, 35 AC
Remote Control Notes

COLONIAL RADIO CORP.

The Remote-Control Automatic-Tuning Unit

will make contact with the other half of the disk, energizing the other field winding. This reverses the motor direction, bringing the disk back until the insulating slit and the contact stud do coincide.

The button marked "Quiet", when pressed, removes the voltage applied to the screen-grids of the R.F. tubes, preventing reception of stations while the automatic-tuning mechanism is in action.

Should either or both of the drive-motors refuse to run, or run in only one direction the following procedure may be followed: Connect one end of a length of wire to contact "C" of the receptacle (fig. 4.) and touch the other end alternately to each lug of the condenser mounted next to the volume control drive motor. If the motors run, and in both directions, the trouble is in either the cable, the remote-control push-button box, or the contacts on the brass disk. A continuity check will reveal the open circuit.

If the motors do not run when the wire is touched to the condenser lugs, the fault may lie in the voltage supply, the motor proper or in the 0.1 mfd filter condensers. An a.c. voltmeter connected from "C" (fig. 4) to the chassis should give a reading of approximately ten volts. If no reading is obtained, the trouble may be either a blown fuse or an open transformer. If a reading is obtained the 0.1 condensers should be tested for breakdown. If they prove perfect, the trouble is in the motor windings. In particular, the brushes should be examined for good contact with the commutator, and the commutator itself brightened with a piece of very fine sandpaper. In time the spider washers in the friction drive may lose some of their tension, resulting in slippage in the drive. These washers are easily removed and bent to increase their tension.

If the line voltage is above 110, the fuse should be in the right side of its mounting, facing the rear of the set. It should be put in the left side for a line voltage of less than 110.

Since the servicing of the remote-control automatic-tuning unit will be simple if its operation is thoroughly understood, the circuit diagram and the following explanation should be studied carefully.

* Fig. 4 shows the circuit used. As is seen, it consists essentially of two motors, one for turning the volume control and the other the tuning condensers, and means for controlling the direction and amount of rotation of the motors from a remote point. Each of the motors has two field windings, poled in such way that switching from one to the other reverses the direction of motor rotation.

When the remote-control push buttons are not pressed, the circuit is open and no current flows through the motors. When the "Vol. Inc." button is pressed, the circuit is completed through that field winding of the volume control motor which will cause rotation in the proper direction to secure an increase of volume. When the "Vol. Dec." button is pressed, the other field winding is connected, the motor runs in the opposite direction, and the volume control is turned to a lower setting. Just before its minimum position, the volume control operates the receiver line switch. Since a friction drive is used no damage will result if the button is kept pressed. After the volume control has reached the limit of its movement, the motor will merely continue running with the friction drive slipping.

* Study of fig. 4 reveals that when any one of the station buttons is pressed, the circuit is completed through the contact stud connected to it and the station-selector motor revolves, turning the tuning condensers and the split brass disk fastened to the condenser shaft. The motor continues to drive the condenser shaft (through a friction drive) until the insulating slit in the brass disk comes directly under the contact stud and breaks the circuit. When the slit is under the contact stud, the tuning condensers are in proper position for reception of the station. Should the momentum of the motor be sufficient to carry the disk past the point where the stud and slit coincide, the stud

Sometimes it is found that volume is better without a ground connection. This is due to the electric light wires acting as an antenna and feeding signals to the receiver. Under such conditions reception will usually be noisy. Connection of the ground wire causes the line filter condensers to effectively drain off both unwanted noise and whatever signal there may be picked up by the line.

The spark obtained when the ground wire is touched to the ground binding post or to the chassis is a normal occurrence. It is due to the discharge of the condensers used in the line filter.

A poor detector tube will create an objectionable hum in the speaker.

The fuse in the double mounting on the rear of the chassis provides a means for compensating for deviation of the line voltage from normal values. Normally the fuse is in the left side of the mounting, facing the rear of the chassis. It should be put in the right side only when the line voltage is known to be consistently below 110 volts. It is important that this adjustment be made, since excessive voltage will shorten the life of the tubes, and insufficient voltage will make the set insensitive.

The two models, 33AC and 34AC, are identical electrically except that Model 34 has a more sensitive loudspeaker, capable of finer reproduction. Further, the push-pull output transformer is mounted on the speaker frame instead of in the receiver chassis, as in the model 33.

The Colonial 33AC and 34AC are obtainable both with and without the remote-control automatic-tuning unit. This unit is easily installed in those receivers not having it as an integral part. It in no way interferes with the ordinary manual operation of the receiver, should that be desired. Either method of control may be used without the necessity for disconnecting, switching or changing anything. The employment of one-control system does not render the other inoperative.

Due to an automatic anti-overloading feature incorporated in the receiver, it will be found that when receiving strong signals, advancing the volume control beyond a certain point will result in a decrease in volume.

ACTUAL VOLTAGES APPLIED TO TUBES

	RF1	RF2	Det.	AF1	AF2	280 Rectifier
Plate Voltage	180v.	180v.	150v.	100v.	240v.
Control-Grid Voltage	-3	-3	-2	-6	-45
Screen-Grid Voltage	90	90	35
Plate Current	3m.a.	3m.a.	0.2m.a.	3m.a.	28m.a.

VOLTAGES AS READ ON A 1000 OHMS PER VOLT METER
(PLATE VOLTAGES ON THE 250V. SCALE; GRID VOLTAGES ON THE 50 V. SCALE)

Plate Voltage	180v.	180v.	60v.	70v.	235v.
Control-Grid Voltage	80	80	12	-0.5	-22
Screen-Grid Voltage	3m.a.	3m.a.	0.2m.a.	3m.a.
Plate Current	3m.a.	3m.a.	0.2m.a.	3m.a.	50 mA each plate

The discrepancies between the applied and the measured voltages result from variations in tubes and from increased voltage drops in series resistors due to the current taken by the voltmeter. Unless the measured voltages differ by more than 25 per cent from those given in the chart, it should not be taken as a definite indication of a fault. Usually any deviation greater than 25 per cent means trouble. These readings assume a 120v. line. If the line voltage differs from 120 volts, the measured voltages will differ from those given in the chart in approximately the same ratio.

MODEL 33,34,35 AC
Parts List

COLONIAL RADIO CORP.

REPLACEMENT PARTS LIST

Circuit Designation	Value	Part No.	Remarks	Circuit Designation	Value	Part No.	Remarks
R 1	100,000 ohms	4635-P	Center-tapped 200,000 ohm resistor	L 1		1821-SA	Ant. primary
R 2	100,000	4635-P	resistor	L 2		1826-SA	R.F. transformer secondary
R 3	750,000	4595-P-6	Orange	L 3		1827-SA	Link coil
R 4	11,000	4593-P	Tapped resistor	L 4		1827-SA	Link coil
R 5	60,000	4593-P		L 5		1823-SA	R.F. transformer primary
R 6	50,000	4593-P		L 6		1826-SA	R.F. transformer secondary
R 7	20,000	4595-P-5	Grey	L 7		1823-SA	R.F. transformer primary
R 8	750,000	4595-P-6	Orange	L 8		1826-SA	R.F. transformer secondary
R 9	750,000	4595-P-6	Orange	L 9		1823-SA	R.F. transformer primary
R 10	200,000	4595-P-2	Brown	L 10		1826-SA	R.F. transformer secondary
R 11	50,000	4595-P-4	Red	L 11		1843-SA	Push-pull input transformer
R 12	200,000	4595-P-2	Brown	L 12		1843-SA	Push-pull output transformer
R 13	400,000	4595-P-1	Yellow	L 13		1835-SA	(Model 33)
R 14	1,000,000	4595-P-7	Blue	L 14		1835-SA	Push-pull output transformer
R 15	20	4529-P	Center tapped	L 15		1866-SA	Cone and voice coil (Model 33)
R 16	20,000	4595-P-5	Grey	L 16		1904-SA-1	Speaker field coil (Model 33)
R 17	50,000	4595-P-4	Red			1959-SA	Speaker field coil (Model 34)
R 18	100,000	4595-P-3	Green	L 17	4.5 henries	1829-SA	Filter choke 4.5 henries
R 19	20	4529-P	Center tapped	L 18		1830-SA	60 cycle power transformer
R 20	800	4596-P	Blue vitreous enamel type resistor	L 19		1952-SA	60 cycle power transformer
R 21	210	4594-P	Center tapped 420 ohm resistor	L 20		1946-SA	25 cycle power transformer
R 22	210	4594-P		L 21		1985-SA	25 cycle power transformer
C 1	00025 mfd.	4534-P	Ant. series condenser	L 22			(Model 34)
C 2	.0003	1842-SA	Tuning condenser	L 23		1964-SA	Model 34—Push-pull output transformer (Primary)
C 3	.2	4527-P				1960-SA	Model 34—Cone, actuating ring and secondary
C 4	.2	4527-P		C 14	.2	4506-P	Model 33 and 34 line switch
C 5	.2	4527-P		C 15	.25		Black lead and adjacent lug
C 6	.5	4514-P	Red lead and adjacent lug	C 16	.2		Black lead and solitary lug
C 7	.2	4514-P	Black lead and adjacent lug	C 17	.0005		Black lead and further lug
C 8	.2	4527-P		C 18	8.		Yellow leads
C 9	.5	4513-P	Black lead and furthest lug in row of three	C 19	8.		Mershon condenser
C 10	.0001	4597-P		C 20	.1		Line buffer
C 11	.005	4513-P	Red lead and middle lug in row of three			4503-P	25 cycle R.F. screen-grid bi-pass condenser
C 12	.0001	4513-P	Black lead and middle lug in row of three			4503-P	
C 13	1.	4513-P	Black lead and nearest lug in row of three			4598-P	
						4724-P	

MODEL 36 DC

COLONIAL RADIO CORP.

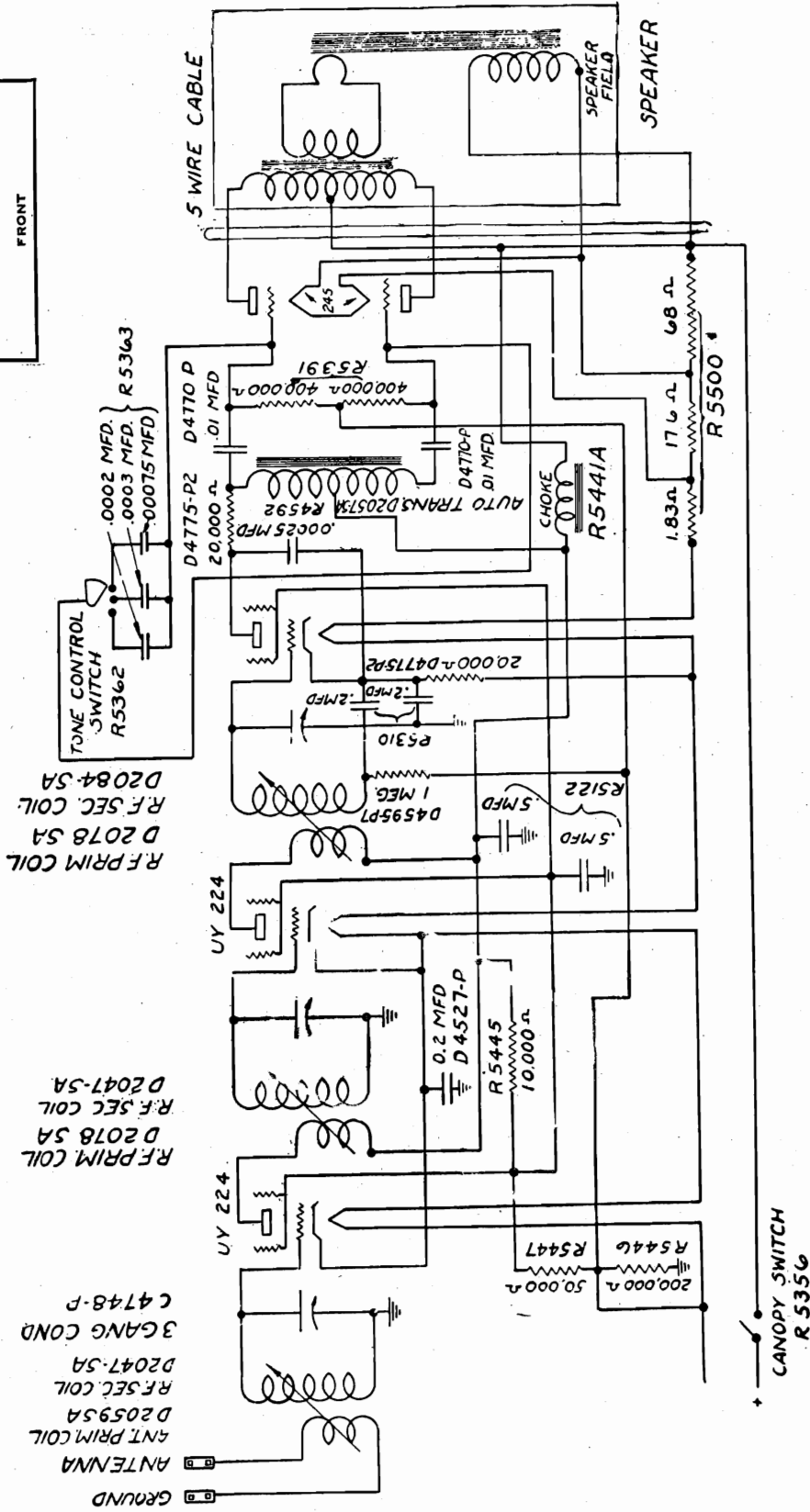
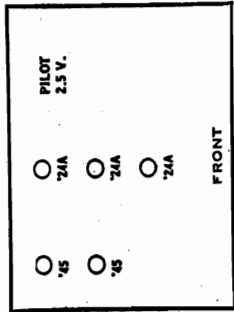

MODEL 37
Chassis

COLONIAL RADIO CORP.

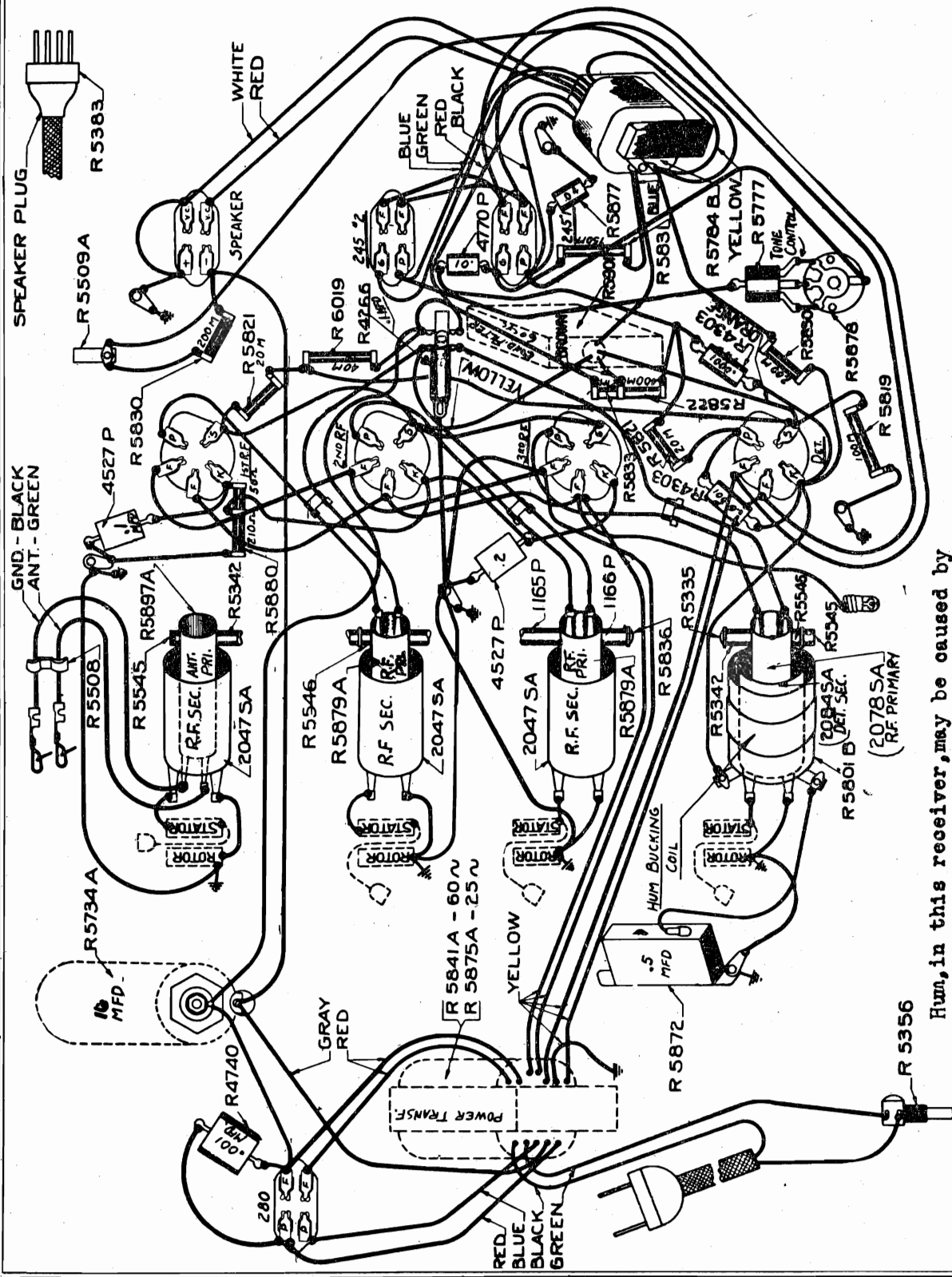

Hum, in this receiver, may be caused by a defective hum bucking coil. This coil is wound on the detector coil shield next to detector socket.

MODEL 37
Parts Coding
Voltage

COLONIAL RADIO CORP

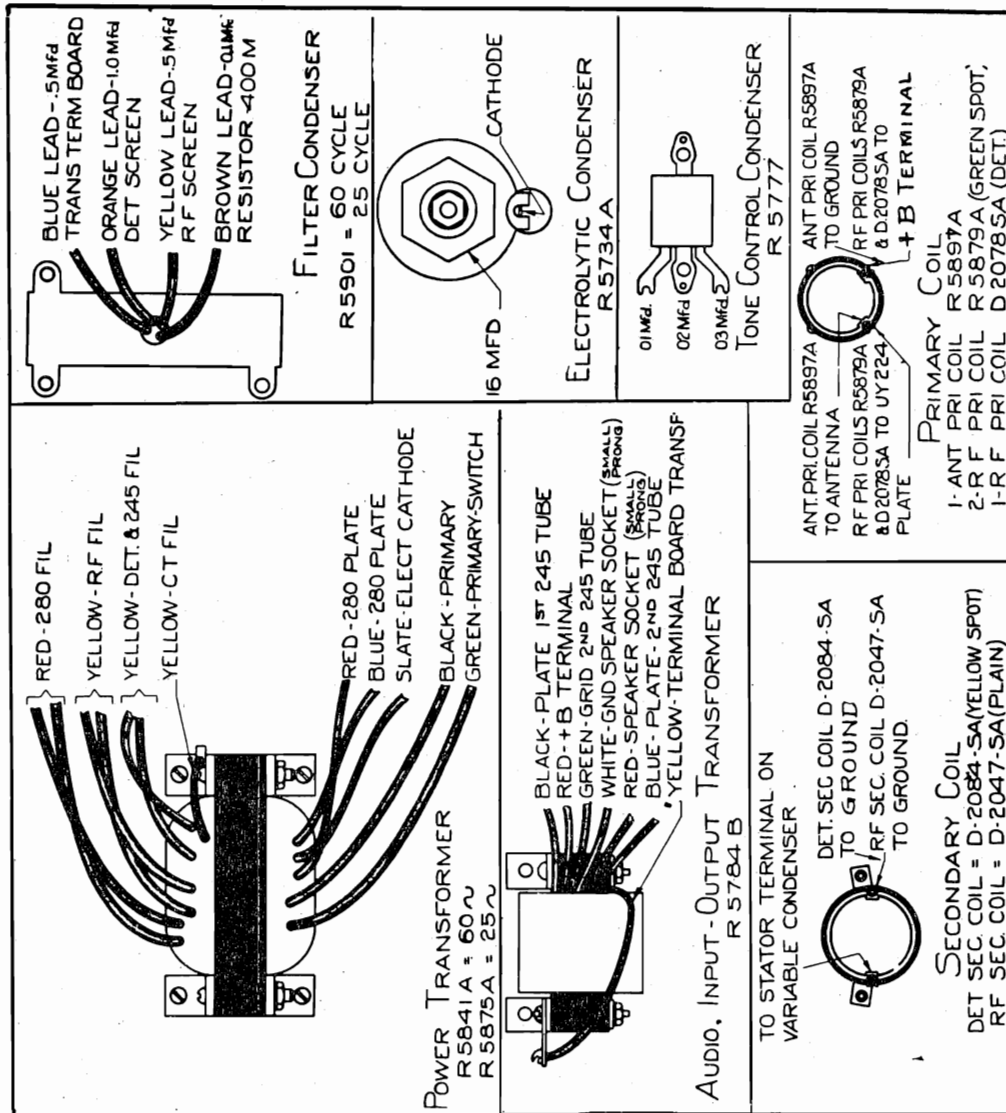

**LEAD DETAILS OF POWER & AUDIO TRANSFORMER, FILTER,
 TONE CONTROL, ELECTROLYTIC CONDENSERS AND R.F. COILS.**

VOLTAGE READINGS - MODELS 37 & 37-P

60 Cycle	Line Voltage 115							
	RF1	RF2	RF3	Det.	245#1	245#2	280AC	280DC
Plate Voltage D.C.	250	250	250	115	250	250	345	350
Screen Voltage D.C.	65	65	65	100				
Heater Voltage A.C.	2.4	2.4	2.4	2.4	2.4	2.4	4.8	
Control Grid Voltage D.C.	2.2	2.4	2.4	10	20	48		
Speaker Field Voltage	100							
Total Rectifier Current	.070							

25 Cycle	Line Voltage 115							
	RF1	RF2	RF3	Det.	245#1	245#2	280AC	280DC
Plate Voltage D.C.	240	240	240	100	240	240	340	340
Screen Voltage D.C.	65	65	65	100				
Heater Voltage A.C.	2.4	2.4	2.4	2.4	2.4	2.4	4.8	
Control Grid Voltage D.C.	2.2	2.4	2.4	10	20	45		
Speaker Field Voltage	100							
Total Rectifier Current MADC	.070							

Control grid voltage measured from cathode to ground or from cathode to filament. 245 grid voltage measured from grid to ground.

MODEL 39, 125
Voltage
Parts Coding

COLONIAL RADIO CORP.

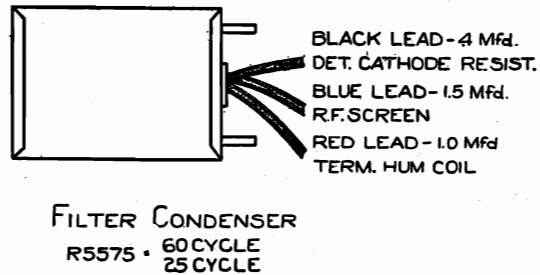
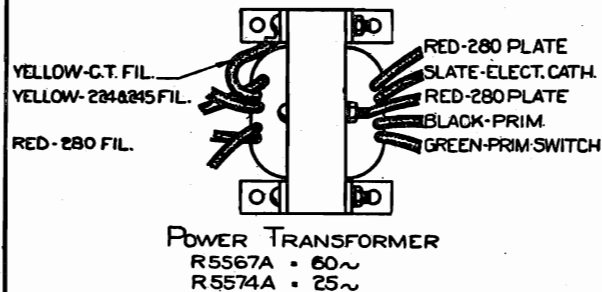

TO STATOR TERMINAL ON
VARIABLE CONDENSER.



R.F. SEC. COIL D-2047-SA
TO GND.
DET. SEC. COIL D-2084-SA
TO GROUND

SECONDARY COIL

DET. SEC. COIL - D-2084-SA (YELLOW SPOT)
R.F. SEC. COIL - D-2047-SA (PLAIN)

ANT. PRIM. COIL D-2059-SA
TO ANT.
R.F. PRIM. COIL D-2078-SA
TO UY 224 PLATE.



ANT. PRIM. COIL D-2059-SA
TO GND.
R.F. PRIM. COIL D-2078-SA
TO +B TERM.

PRIMARY COIL

ANT. PRIM. COIL - D-2059-SA (YELLOW SPOT)
R.F. PRIM. COIL - D-2078-SA (PLAIN)

CATHODE

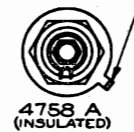

GND.



ELECTROLYTIC CONDENSERS

Model 39 — LEAD DETAILS OF POWER TRANSFORMER, FILTER & ELECTROLYTIC CONDENSERS, PRIMARY & SECONDARY R.F. COILS.

60 Cycle Line Voltage 115

	RF1	RF2	Det.	245#1	245#2	280AC	280DC
Plate Voltage D.C.	245	245	120	240		320	340
Screen Voltage D.C.	75	75	75				
Heater Voltage A.C.	2.4	2.4	2.4	2.4		4.85	
Control Grid Voltage D.C.	2.6	2.6	7	30			
Speaker Field Voltage						100	
Total Rectifier Current	.040						

25 Cycle Line Voltage 115

	RF1	RF2	Det.	245#1	245#2	280AC	280DC
Plate Voltage D.C.	250	250	110	245		325	350
Screen Voltage D.C.	75	75	75				
Heater Voltage A.C.	2.4	2.4	2.4	2.4		4.85	
Control Grid Voltage D.C.	2.5	2.5	7.5	30			
Speaker Field Voltage						100	
Total Rectifier Current	.040						

Note: Control grid volts are measured from Cathode to ground or Cathode to Heater. 245 Grid Voltage measured from Grid to Ground or Filament.

Model 39 (1931)

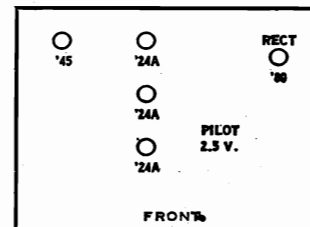

COLONIAL RADIO CORP.

MODEL 39
125
Chassis

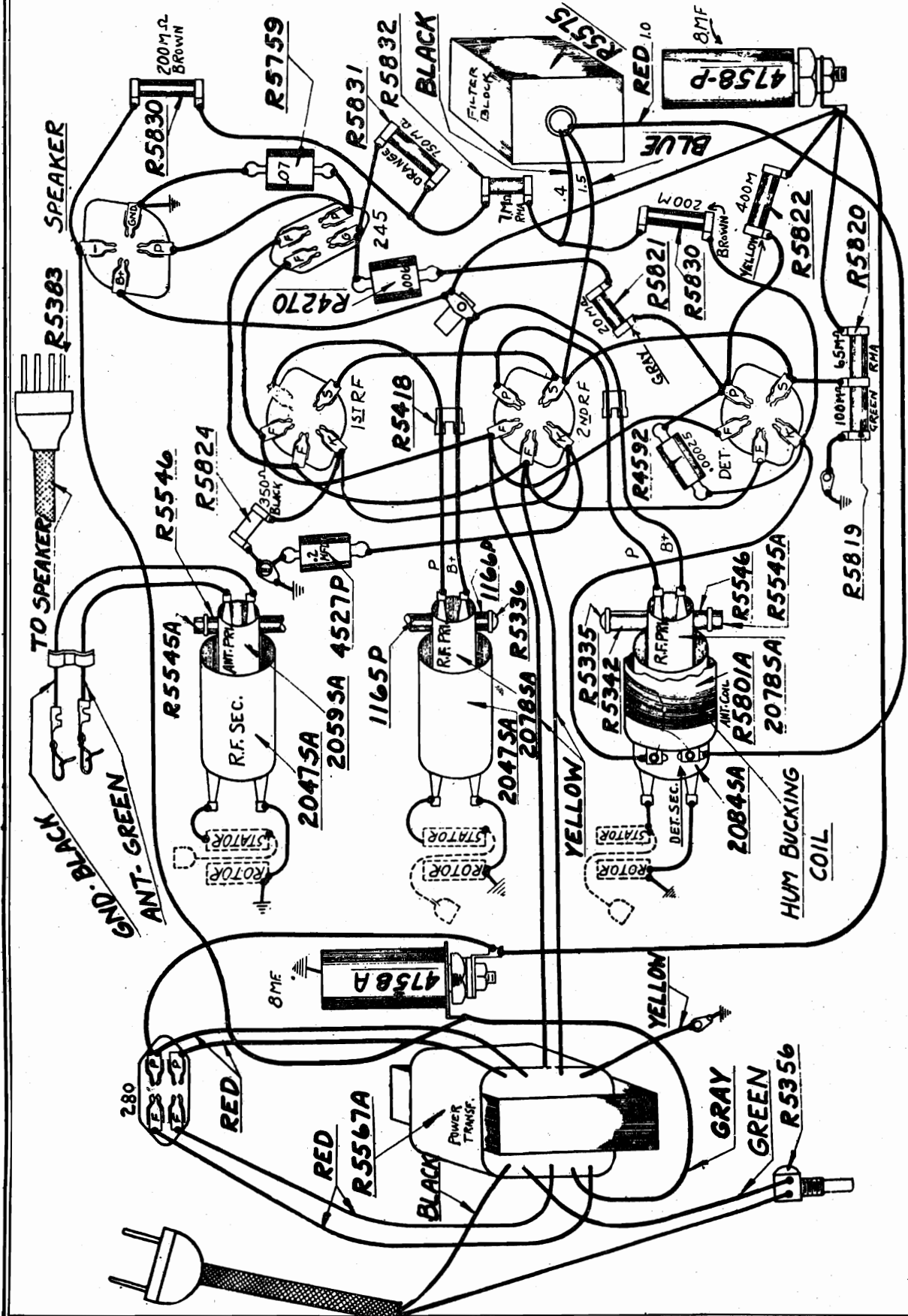

MODELS 39 & 125

MODEL 40, 43
Battery
Chasses

COLONIAL RADIO CORP.

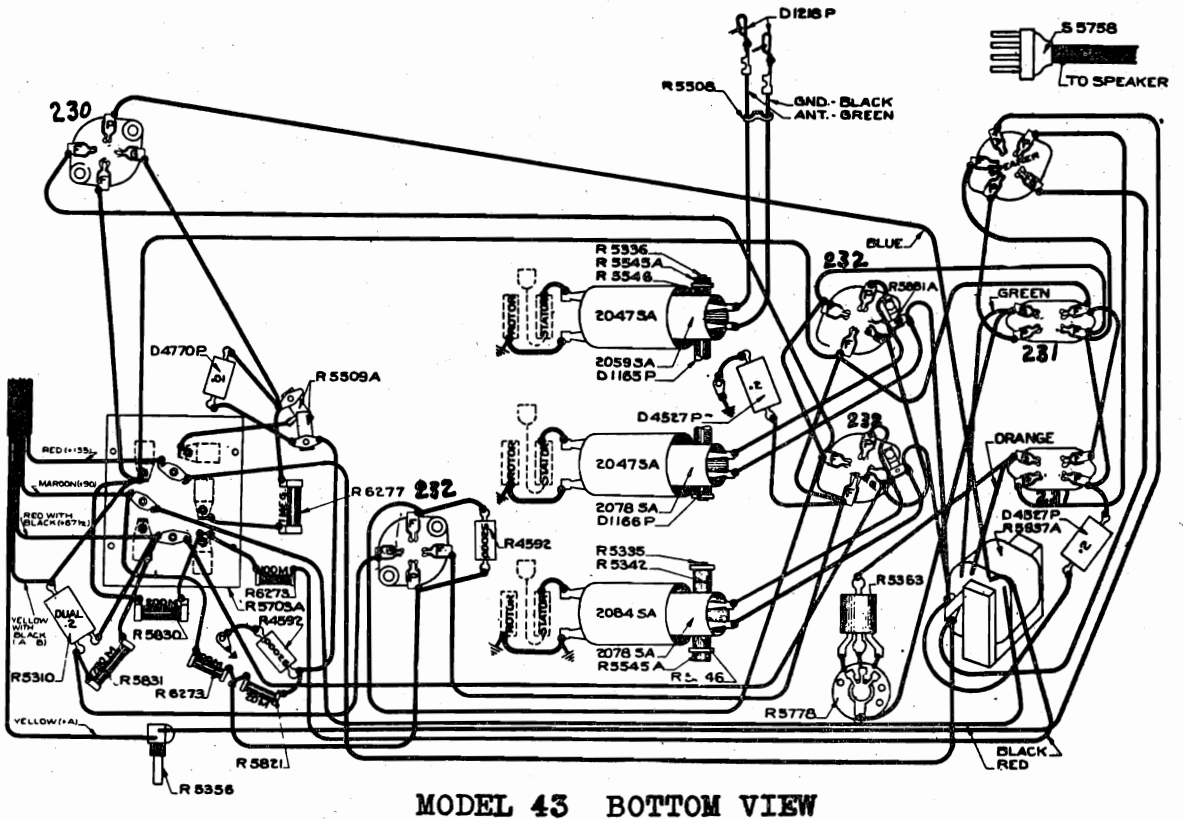
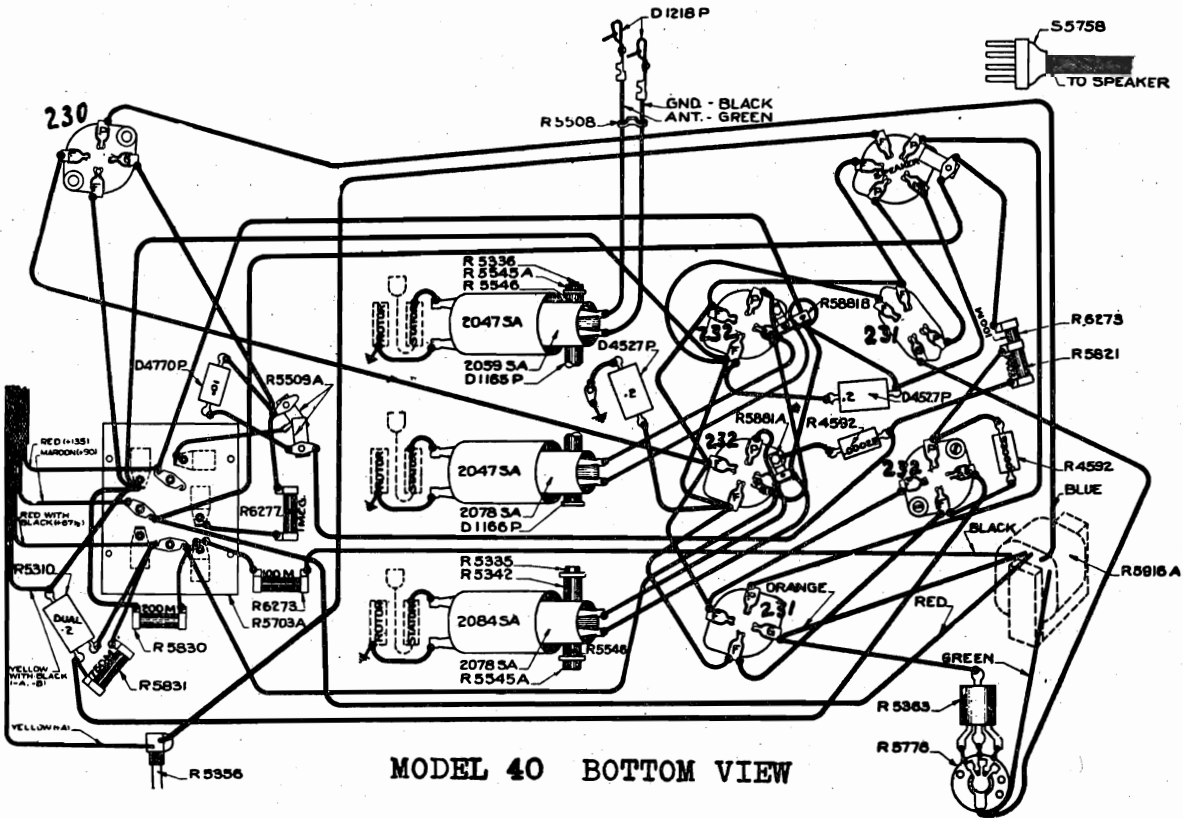

COLONIAL RADIO CORP.

MODEL 40, 43
Battery
Schematic

Model 40	RF1	RF2	Det.	1st Audio	2S1
Plate Voltage D.C.	135	135	80	90	130
Screen Voltage D.C.	87	87	25		
Filament Voltage D.C.	2.0	2.0	2.0	2.0	2.0
Control Grid Voltage D.C.	3	3		4.5	22.5

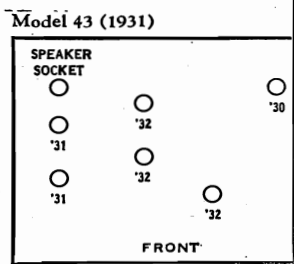
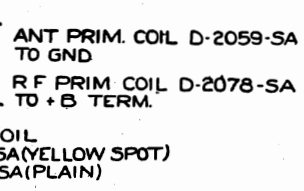
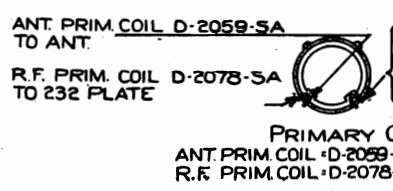
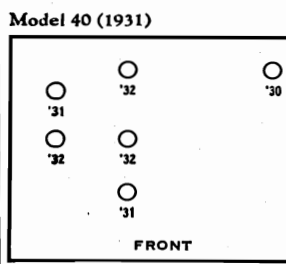
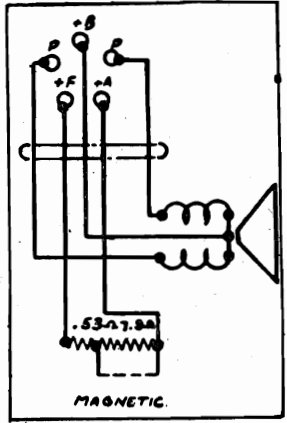
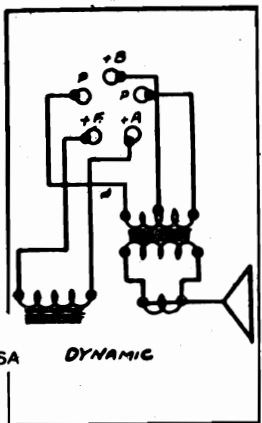
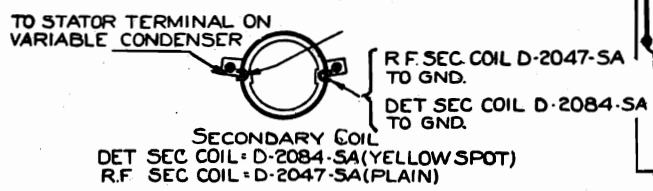
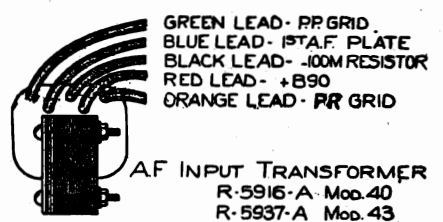
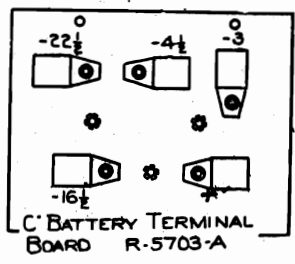
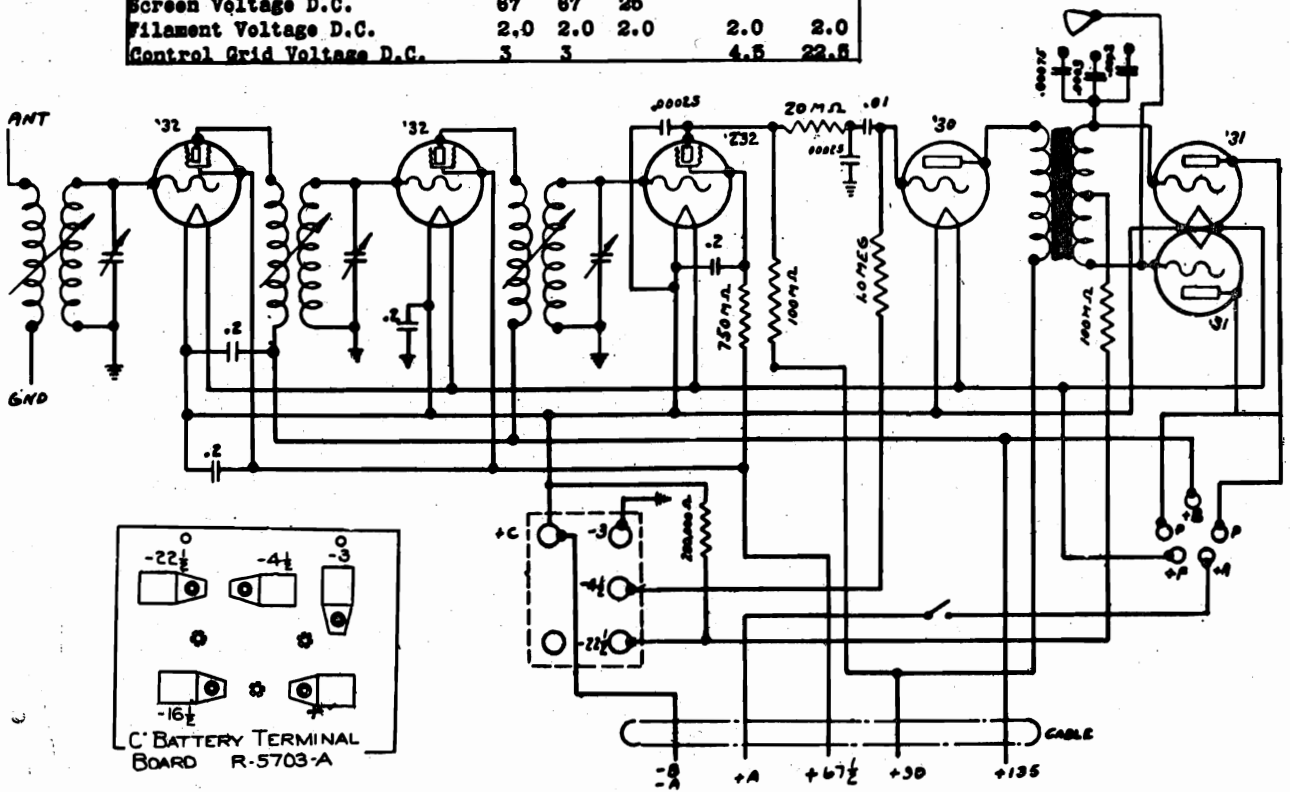

MODEL 41-P
Schematic

COLONIAL RADIO CORP.

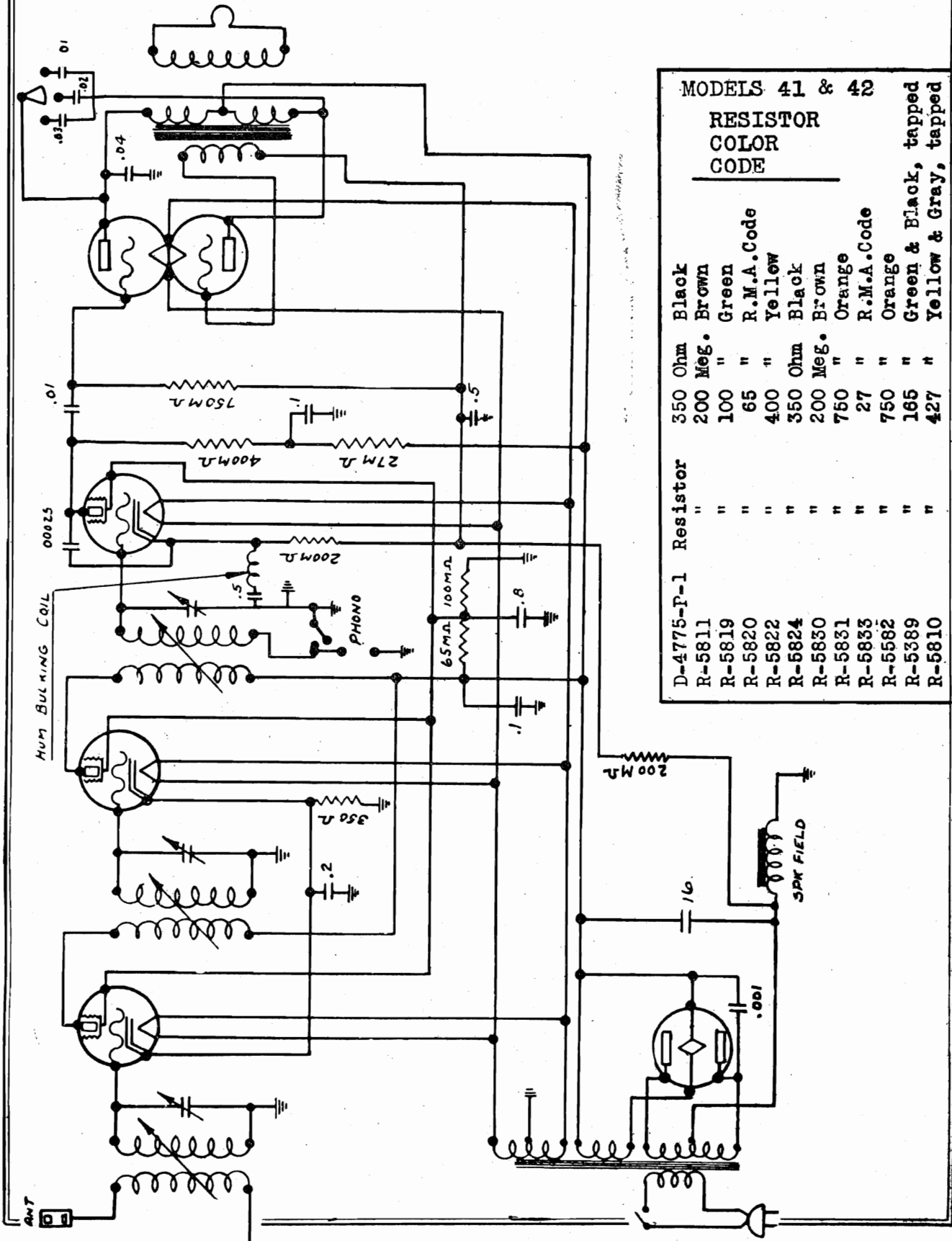

MODELS 41 & 42
RESISTOR
COLOR
CODE

Resistor	Value	Color Code
D-4775-P-1	350 Ohm	Black
R-5811	200 Meg.	Brown
R-5819	100 "	Green
R-5820	65 "	R.M.A. Code
R-5822	400 "	Yellow
R-5824	350 Ohm	Black
R-5830	200 Meg.	Brown
R-5831	750 "	Orange
R-5833	27 "	R.M.A. Code
R-5833	750 "	Orange
R-5882	165 "	Green & Black, tapped
R-5389	427 "	Yellow & Gray, tapped
R-5810		

MODEL 42
Chassis

COLONIAL RADIO CORP.

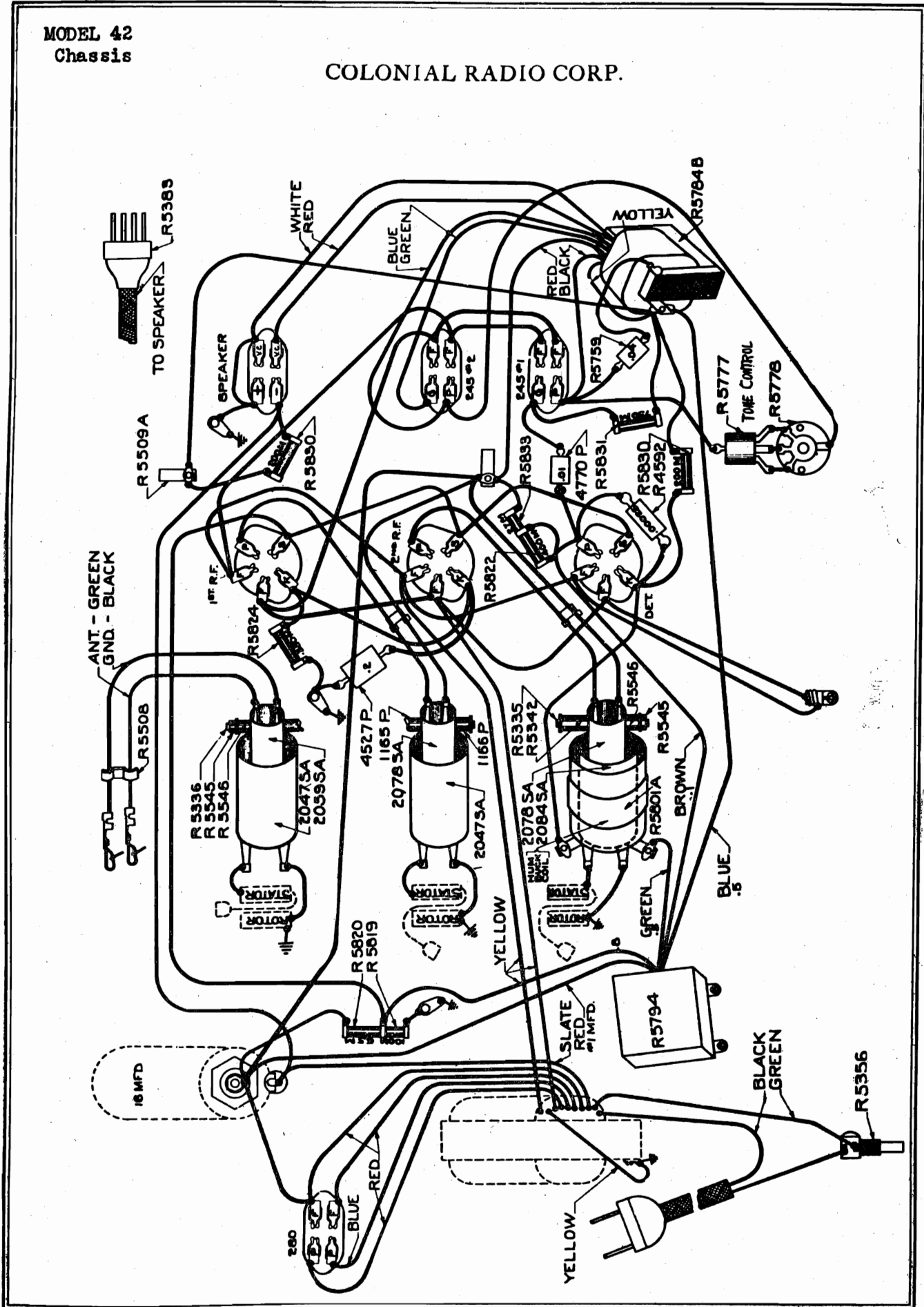

MODELS 41 and 42
Parts Coding

COLONIAL RADIO CORP.

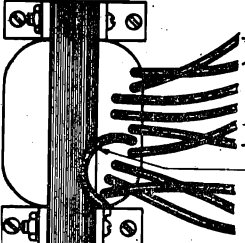
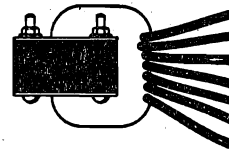
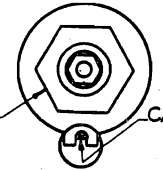
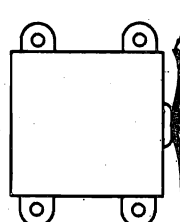
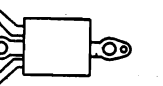
 <p>RED-280 FIL GREEN-PRIM SWITCH BLACK-PRIM YELLOW-224 & 245 FIL YELLOW-CT. FIL. RED-280 PLATE BLUE-280 PLATE SLATE-ELECT CATHODE</p>	 <p>BLACK-PLATE 1ST 245 TUBE RED- +B TERMINAL GREEN-GRID 2ND 245 TUBE WHITE-SPEAKER SOCKET (SMALL PRONG) RED-GND.SPEAKER SOCKET (SMALL PRONG) BLUE-PLATE-2ND 245 TUBE YELLOW- TERMINAL BOARD</p> <p>AUDIO INPUT-OUTPUT TRANSFORMER R 5784 A</p>	
<p>POWER TRANSFORMER R 5779 A = 60 ~ R 5826 A = 25 ~</p>	<p>ANT.PRIM.COIL D-2059-SA TO ANT R.F.PRIM.COIL D-2078-SA TO UY 224 PLATE ANT.PRIM.COIL D-2059-SA TO GND. R.F.PRIM.COIL D-2078-SA TO +B TERM</p>	 <p>16 MFD. CATHODE</p> <p>ELECTROLYTIC CONDENSER R 5734 A</p>
 <p>GREEN LEAD-.5MFD HUM COIL TERM RED LEAD-.1MFD ELECT. CONDENSER YELLOW LEAD-.8MFD R.F SCREEN BROWN LEAD-.1MFD RESISTOR 400M BLUE LEAD-.5MFD TERM. BOARD</p>	<p>PRIMARY COIL ANT PRIM.COIL = D-2059-SA(YELLOW SPOT) R.F. PRIM.COIL = D-2078-SA(PLAIN)</p> <p>TO STATOR TERMINAL ON VARIABLE CONDENSER</p>	 <p>.01MF .02MF .03MF</p> <p>TONE CONTROL CONDENSER R 5777</p>
<p>FILTER CONDENSER R 5794 = 60 CYCLE 25 CYCLE</p>	<p>SECONDARY COIL DET SEC. COIL = D 2084 SA (YELLOW SPOT) R.F. SEC. COIL = D 2047 SA (PLAIN)</p> <p>DET SEC. COIL D-2084-SA TO GROUND R.F. SEC. COIL D-2047-SA TO GND.</p>	
<p>LEAD DETAILS OF POWER & AUDIO TRANSFORMER, FILTER, TONE CONTROL & ELECTROLYTIC CONDENSERS, PRIMARY & SECONDARY R F COILS</p> <p style="text-align: right;"><u>MODEL 41</u></p>		

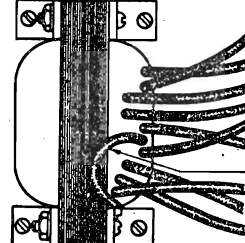
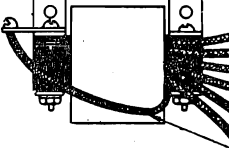
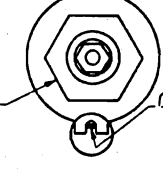
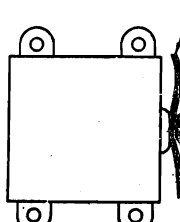
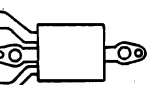
 <p>RED-280 FIL GREEN-PRIM SWITCH BLACK-PRIM YELLOW-224 & 245 FIL YELLOW-CT FIL RED-280 PLATE BLUE-280 PLATE SLATE-ELECT.CATHODE</p>	 <p>BLACK-PLATE 1ST 245 TUBE RED- +B TERMINAL GREEN-GRID 2ND 245 TUBE WHITE-GND SPEAKER SOCKET (SMALL PRONG) RED SPEAKER SOCKET (SMALL PRONG) BLUE-PLATE-2ND 245 TUBE YELLOW-TERM BOARD TRANSF</p> <p>AUDIO INPUT-OUTPUT TRANSFORMER R 5784 B</p>	
<p>POWER TRANSFORMER R 5779 A = 60 ~ R 5826 A = 25 ~</p>	<p>ANT PRIM COIL D-2059SA TO ANT R.F. PRIM COIL D-2078-SA TO UY 224 PLATE ANT PRIM COIL D-2059-SA TO GND R.F. PRIM COIL D-2078-SA TO +B TERM</p>	 <p>16 MFD. CATHODE</p> <p>ELECTROLYTIC CONDENSER R 5734 A</p>
 <p>GREEN LEAD-.5MFD HUM COIL TERM RED LEAD-.1MFD ELECT. CONDENSER YELLOW LEAD-.8MFD R.F SCREEN BROWN LEAD-.1MFD RESISTOR 400M BLUE LEAD-.5MFD TERM BOARD</p>	<p>PRIMARY COIL ANT PRIM COIL = D-2059-SA(YELLOW SPOT) R.F. PRIM COIL = D-2078-SA(PLAIN)</p> <p>TO STATOR TERMINAL ON VARIABLE CONDENSER</p>	 <p>.01MF .02MF .03MF</p> <p>TONE CONTROL CONDENSER R 5777</p>
<p>FILTER CONDENSER R 5794 = 60 CYCLE 25 CYCLE</p>	<p>SECONDARY COIL DET SEC. COIL = D-2084 SA (YELLOW SPOT) R.F. SEC. COIL = D-2047-SA (PLAIN)</p> <p>DET SEC. COIL D 2084 SA TO GROUND R.F. SEC. COIL D-2047-SA TO GND</p>	
<p>LEAD DETAILS OF POWER & AUDIO TRANSFORMER, FILTER, TONE CONTROL & ELECTROLYTIC CONDENSERS, PRIMARY & SECONDARY R F COILS.</p> <p style="text-align: right;"><u>MODEL 42</u></p>		

FOR ADDITIONAL DATA (RESISTOR COLOR CODE) SEE PAGE 208-B-16

COLONIAL RADIO CORP

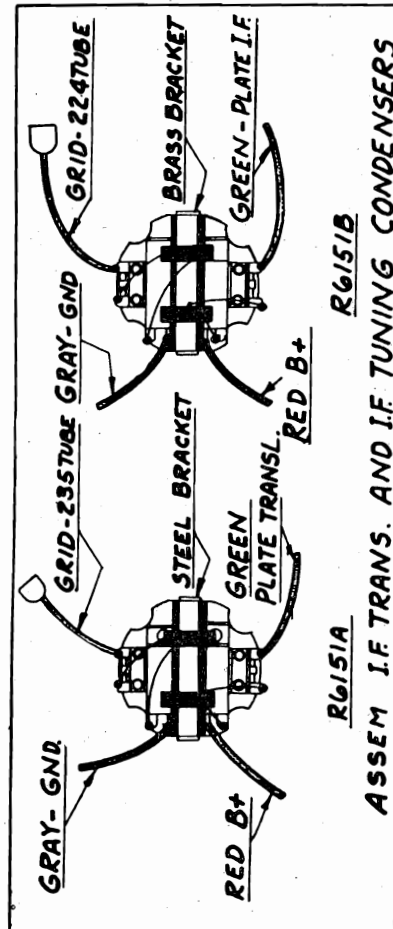

R6151A
R6151B
ASSEM I.F. TRANS. AND I.F. TUNING CONDENSERS

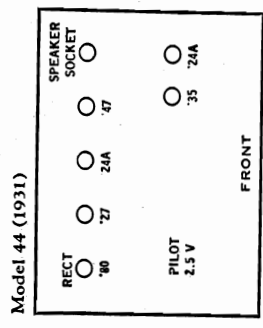

Model 44 (1931)

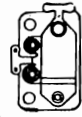

SUPPRESSOR COND. R6218



**TONER CONTROL
CONDENSER R6146**

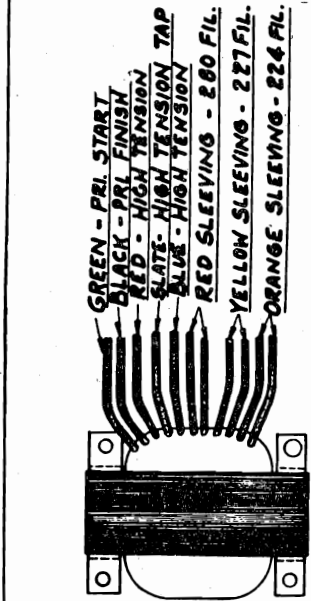

POWER TRANSFORMER
60 CYCLE R6160
25 CYCLE R6085

- LEAD-CODE
RED .1MF. 1MΩ RESISTOR
BLUE .5MF. DET. SCREEN
GREEN 1.0MF. DET. CATH.
BLACK .3MF. CT. 200MΩ RE.
BLACK .3MF. END 200MΩ RE.
BROWN .2MF. I.F. TR. SCREEN
YELLOW .2MF. I.F. CATH.
CAN - COMMON

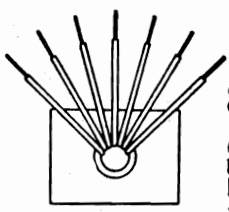

FILTER CONDENSER
R6131

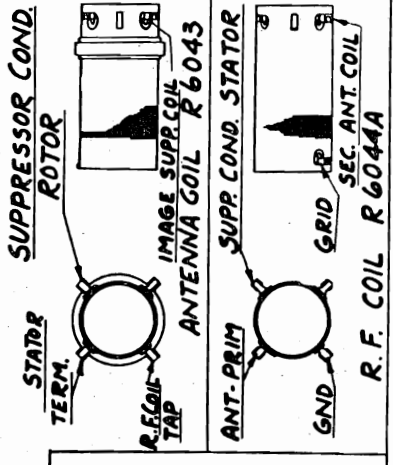

SUPPRESSOR COND. ROTOR

ANTENNA COIL R6043

SUPR. COND. STATOR
R.F. COIL R6044A

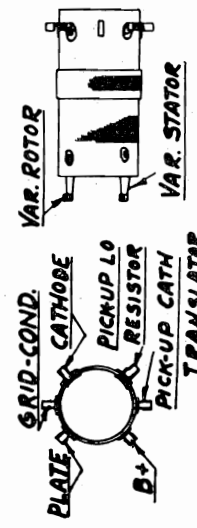

VAR. ROTOR
VAR. STATOR
OSCILLATOR COIL R6008

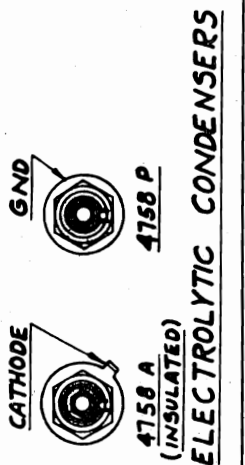

ELECTROLYTIC CONDENSERS

**LEAD DETAILS OF POWER TRANSFORMER - I.F. TRANS. - I.F. TUNING COND - FILTER. TONER CONTROL
ELECTROLYTIC & SUPPRESSOR CONDENSERS. R.F. - ANT OSCILLATOR COILS**

MODEL-44

COLONIAL RADIO CORP.

MODEL 46 Midget
Chassis
Parts Coding

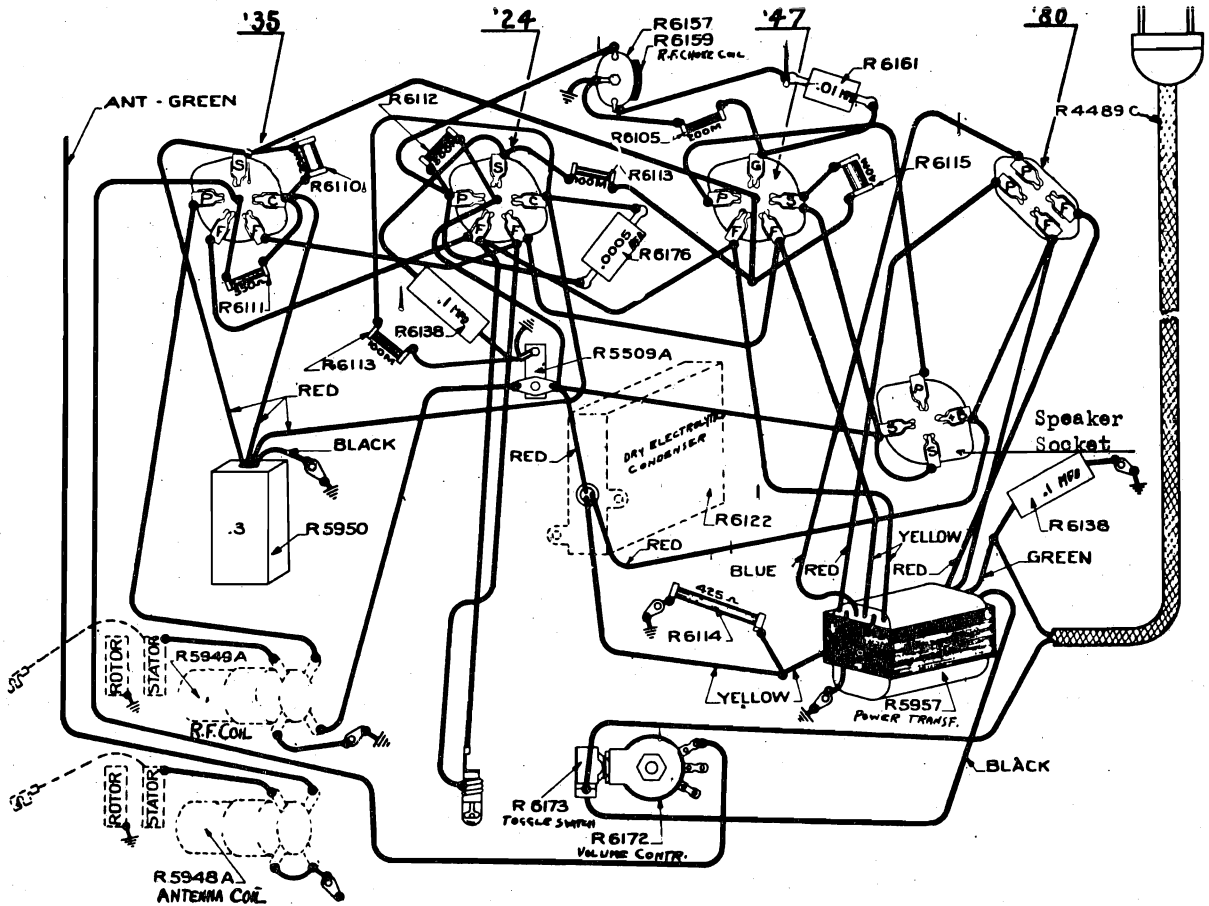

<p>YELLOW - TO 425 Ω RESISTOR</p> <p>LONG RED - 1ST FILTER SECTION</p> <p>SHORT RED TO TERM. BOARD</p> <p>DRY ELECTROLYTIC COND R6122</p>	<p>GROUND ANT</p> <p>GROUND GRID TO STATOR TERM</p> <p>ANT COIL R5948A</p>	<p>B+ TO TERM BOARD PLATE 235 TUBE</p> <p>GROUND GRID TR STATOR TERM</p> <p>R.F. COIL R5949A</p>
<p>GREEN PRI. BLACK PRI. RED SLEEVING 280 FIL.</p> <p>YELLOW - FIL. YELLOW - CT TO BIAS RES. YELLOW - FIL. RED - HIGH TENSION SLATE - HIGH TENSION TAP BLUE - HIGH TENSION</p> <p>POWER TRANSFORMER 60 CYCLE R5957</p>		

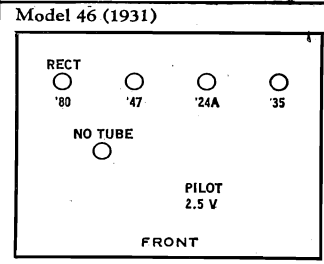

**MODEL 47,48 Super
Schematic
Voltage**

COLONIAL RADIO CORP.

60 Cycle Total Watts - 80	Tran.	Osc.	I.F.	R.F.	Det.	2-247	280AC	280DC
Line Voltage - 115								
Plate Voltage DC	230	40	240	240	160	235	240	350
Screen Voltage DC	65		65	65	20	240		
Heater Voltage AC	2.44	2.44	2.44	2.44	2.44	2.45	4.85	
Control Grid Voltage DC	10		1.7-40	1.7-40	20	16		
Speaker Field Voltage	110 Volts.							
Total Plate Current	1075 amp.							

25 Cycle Total Watts - 85	Tran.	Osc.	I.F.	R.F.	Det.	2-247	280AC	280DC
Line Voltage - 115								
Plate Voltage DC	220	40	230	230	160	225	325	340
Screen Voltage DC	70		70	70	25	230		
Heater Voltage AC	2.25	2.25	2.25	2.25	2.45	2.45	4.7	
Control Grid Voltage DC	10		2-38	2-38	20	15		
Speaker Field Voltage	100 Volts							
Total Plate Current	.075 amp.							

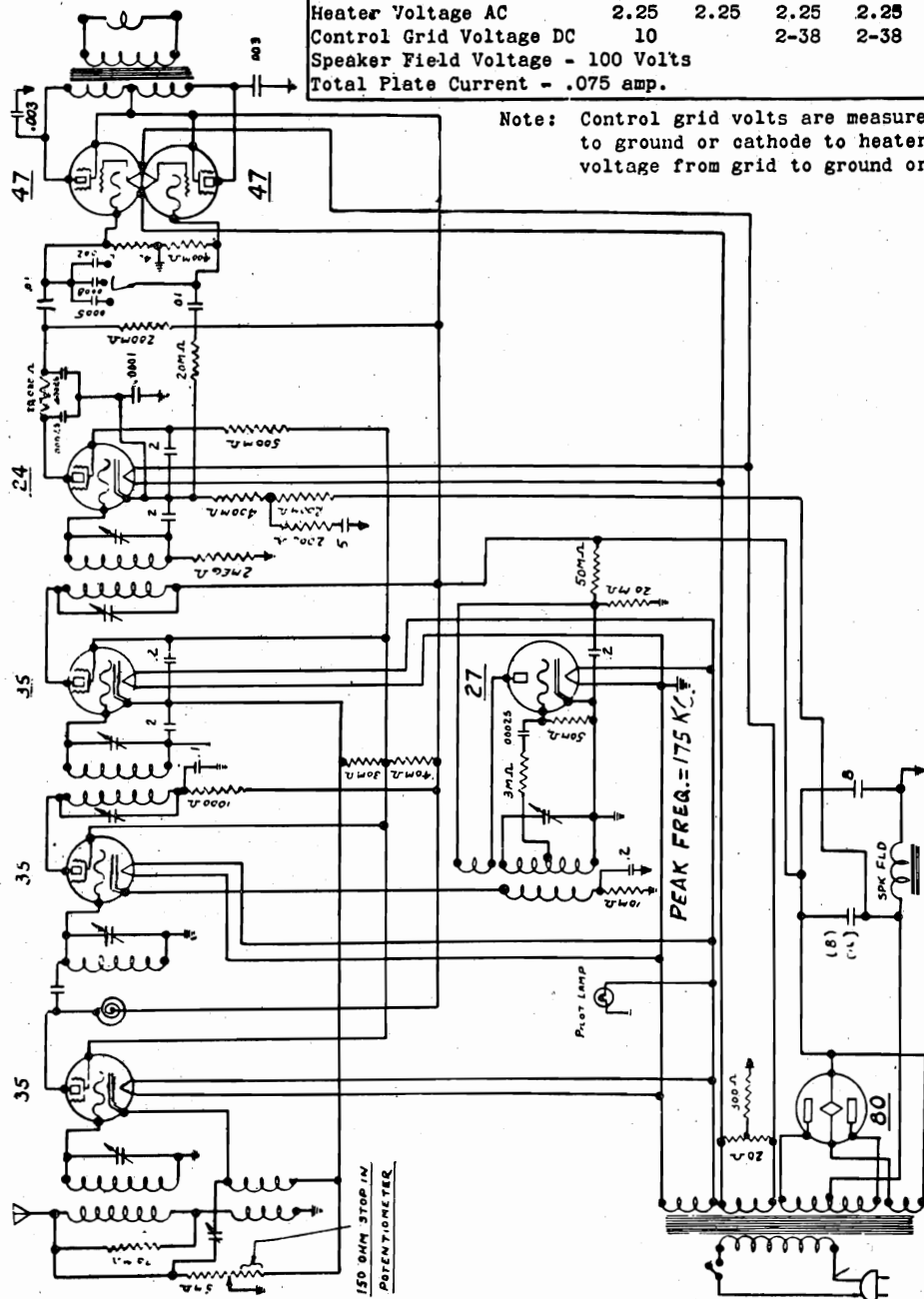

Note: Control grid volts are measured from cathode to ground or cathode to heater. 247 grid voltage from grid to ground or filament.

MODELS 47-48 SUPERHET.

NOTE-In this set the hum across the field coil is used to buck out hum set up in the tube circuits. Causes of hum can be traced to defective detector or output tubes. (interchange output tubes) Shorted condenser or open resistors in hum filter circuit. The hum filter circuits consists of a 2000 ohm resistor and a 0.5 condenser in the grid bias resistor circuit. This connects from the cathode of the detector to the negative side of the speaker field. Other causes of hum are Reversed speaker field, open or shorted condensers in detector circuit, open or grounded 20 ohm center tapped resistor, defective tone control, defective speaker or a defective electrolytic condenser.

Models 47, 48 (1931)

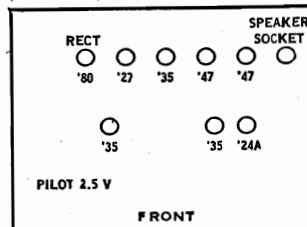

MODEL 47, 48
Parts Coding

COLONIAL RADIO CORP.

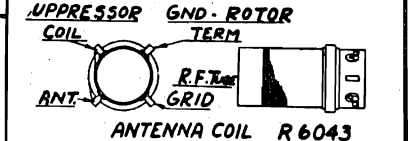
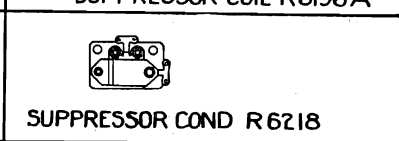
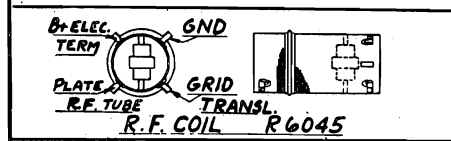
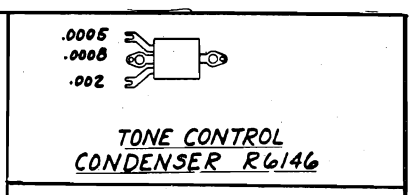
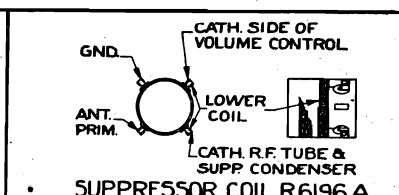
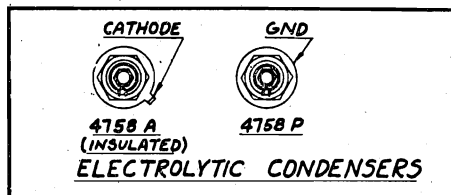
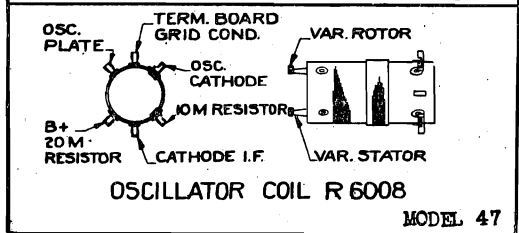
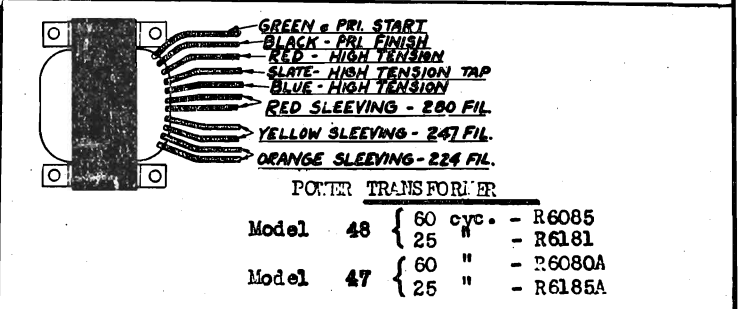
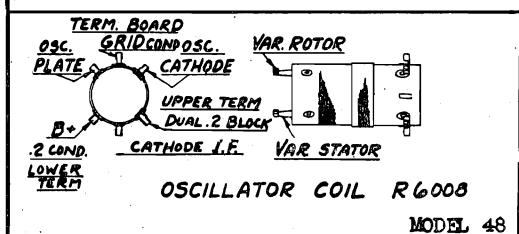
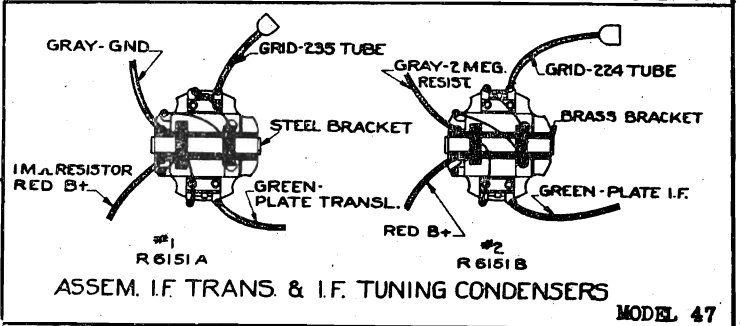
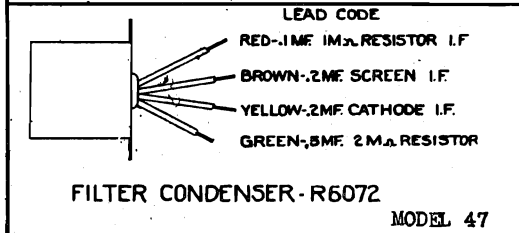
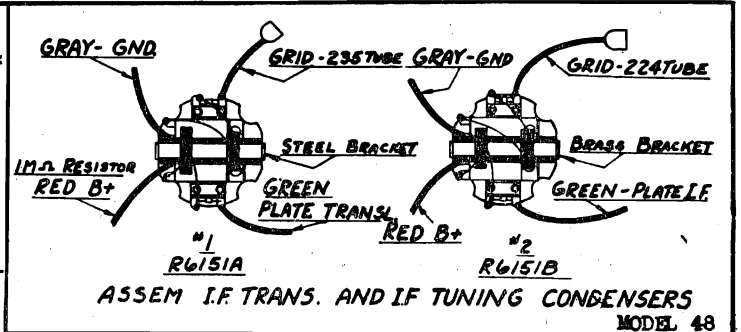
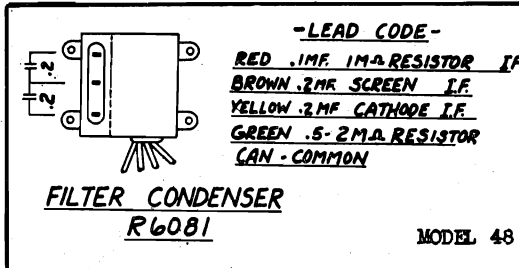

MODELS 47 & 48

MODELS 47 AND 48

MODEL 50 AVC
Voltage
Parts Coding

COLONIAL RADIO CORP.

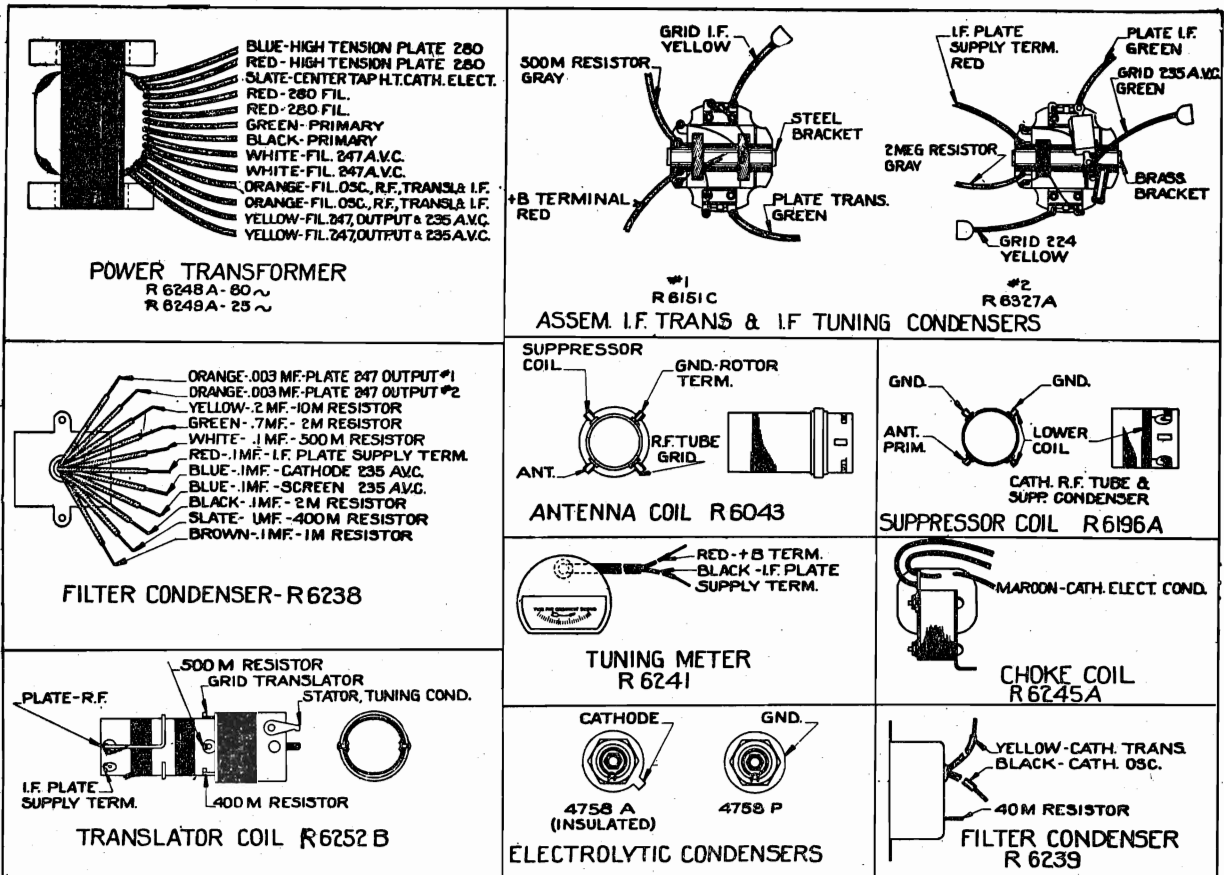

LEAD DETAILS OF POWER TRANSFORMER-I.F. TRANS.-I.F. TUNING COND.-FILTER COND.-ELECTROLYTIC COND.-ANTENNA, SUPPRESSOR, TRANSLATOR AND CHOKE COILS - TUNING METER.

MODEL 1430 - 60 CYCLE									
Line Voltage	115					#1	#2	AVC	AVC
Total Watts	100					247	247	Amp	280 280
		Trans	Osc.	IF	RF	Det	Output	Output	235 247 AC DC
Plate Voltage	230		20	230	230	160	230	230	340 340
Screen Voltage	70			70	70	25	230	70 100	
Grid Voltage	var			var.	var.	20	15	var.	18
Filament Voltage	2.5		2.5	2.5	2.5	2.5	2.5	2.5	4.85
Speaker Field Voltage	-		110						
Total Plate Current	-		80 ma.						

Note: All voltages measured with a 1000 ohm per volt meter, 250 volt scale, with volume level control at maximum. 247 output grid voltages were measured from filament to ground, and translator grid from cathode to ground. Grid voltages on the RF and IF will be variable when the set is operating. AVC plate voltages will be the grid voltages on RF, IF and translator tubes.

Notes-Causes of no signals can be traced to some of the following reasons. Grid clips shorted to tops of tube shields. Open or shorted condensers. Unsoldered leads. Solder under tube socket terminals. Defective tubes. Oscillator not working. Open image suppressor coil. Defective speaker or shorted tone control connection. Poor quality can be traced to defective output or detector tubes. Set not tuned properly. A poor 235 in the IF, RF or translator sockets will give poor quality and unsatisfactory volume control. Shorted or open grid

coupling condenser in the audio circuit, or open resistors in the audio circuits will also contribute to poor quality. Oscillation can be traced to defective tubes, grid leads of detector and IF too close, or an open condenser in the plate circuit of the translator.

MODEL-50

COLUMBIA PHONOGRAPH COMPANY

MODEL 31,33
Layout
Notes

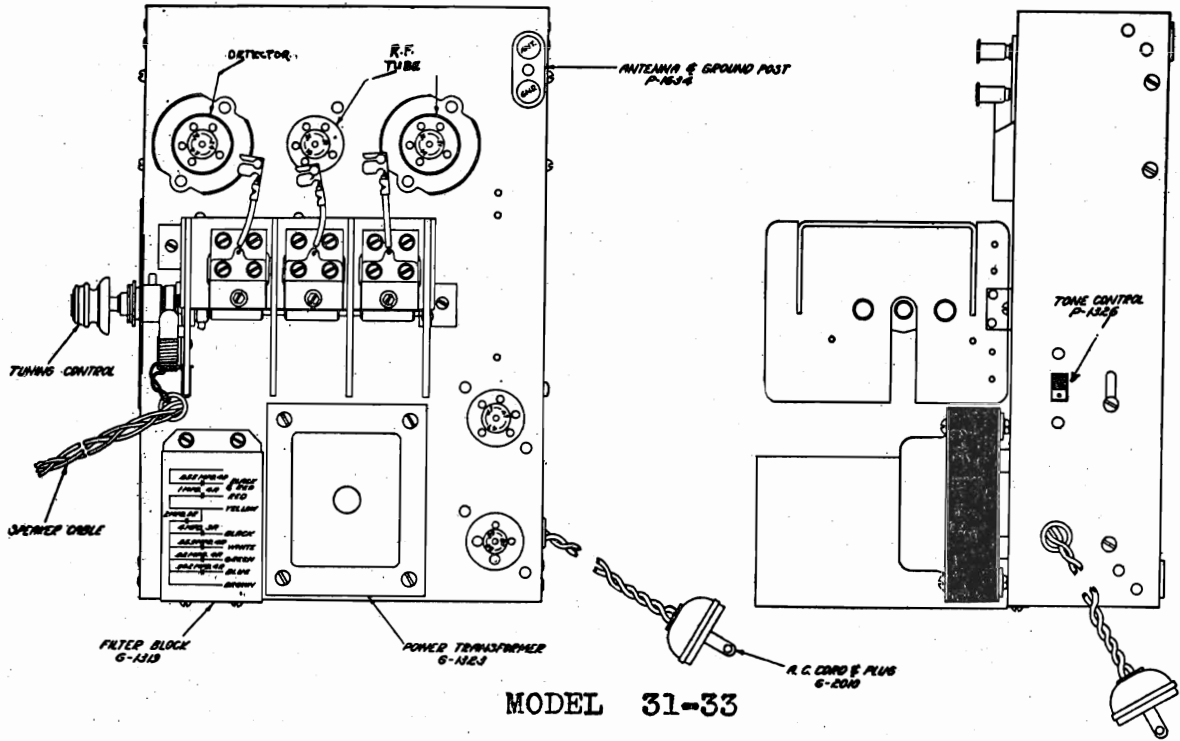

MODEL 31-33

MODEL 40 CONTINUITY TEST TABLES

(Using 10-volt scale 1,000 ohms per volt: meter with 6-volt battery)

Circuit Tested	From	To	Reading	Your Reading
Ant. coil pri.	Ant. post	Ground	6.	
Ant. coil sec.	Grid 1st tube	Ground	6.	
1st R. F. Plate ckt.	Plate of tube	Brown lead of filter pack	6.	
1st R. F. Screen ckt.	Screen prong	Center lead, Voltage divider	6.	
1st R. F. Cathode ckt.	Cath. prong	Center tap Volume Control "ON"	6.	
2nd R. F. Grid ckt.	Grid Clip	Ground	6.	
2nd R. F. Plate ckt.	Plate prong	Brown lead of filter pack	6.	
2nd R. F. Screen ckt.	Screen prong	Center tap Voltage divider	6.	
2nd R. F. Cathode ckt.	Cathode prong	Center tap Volume Control "ON"	6.	
Det. Grid ckt.	Grid Clip	Ground	6.	
Det. Plate ckt.	Plate prong	Brown lead of filter pack	6.	
Det. Screen ckt.	Screen prong	Center Voltage divider	6.	
Det. Cathode ckt.	Cathode prong	Ground	1.4	
P. Z. cont. grid	Grid prong	Sec output trans. black lead (slight deflection)		
P. Z. space chg. grid ckt.	S. C. Grid Prong	Brown lead of filter pack	6.	
P. Z. Plate ckt.	Plate prong	Brown lead of filter pack	5.7	
Output Sec.	One side	Other side	5.9	
Pri Power Trans.	Across A. C. Plug	Switch on	5.9	
Hi volts Sec.	Across 280 plate prongs		5.6	
Speaker field	Red wire	Green Wire	5.4	
Speaker voice coil	Green wire	Black	6.	
Filter Choke	Across red leads		5.6	
Voltage divider	Ground	Brown lead of filter pack	2.2	

RESISTANCE TABLE MODEL 40

(Using 10-volt range meter 1,000 ohms per volt and 6-volt battery)

Item	Color Code*	From	To	Reading	Your Reading	Resistance in Ohms
Det. Cath. Resistor	Yel., Blk., Or.	Det. Cath.	Gnd.	1.3		40,000
Pent. Grid Resistor	Br. Blk., Green	Pent Grid	Splr. Field	Slight Deflection		1,000,000
Wire Wound	Black	Voice Coil, Black	Gnd.	5.9		280
Voltage Divider, Short End	Black	Volume Cont. Green Lead	S. G. Ckt	4.2		4,100
Voltage Divider, Long End	Black	Plate	S. G. Ckt.	3.		11,000
Det. Plate Resistor	Gr., Blk., Yellow	Det. Plate	Pent. Space Chg. Grid.	.1		500,000
Vol. Control "on"		Gnd.	R. F. Cathode	4.2		4,100

*Color code: read body color first, tip second and dot last.

MODEL 31,33
Schematic
Voltage
Layout

COLUMBIA PHONOGRAPH COMPANY

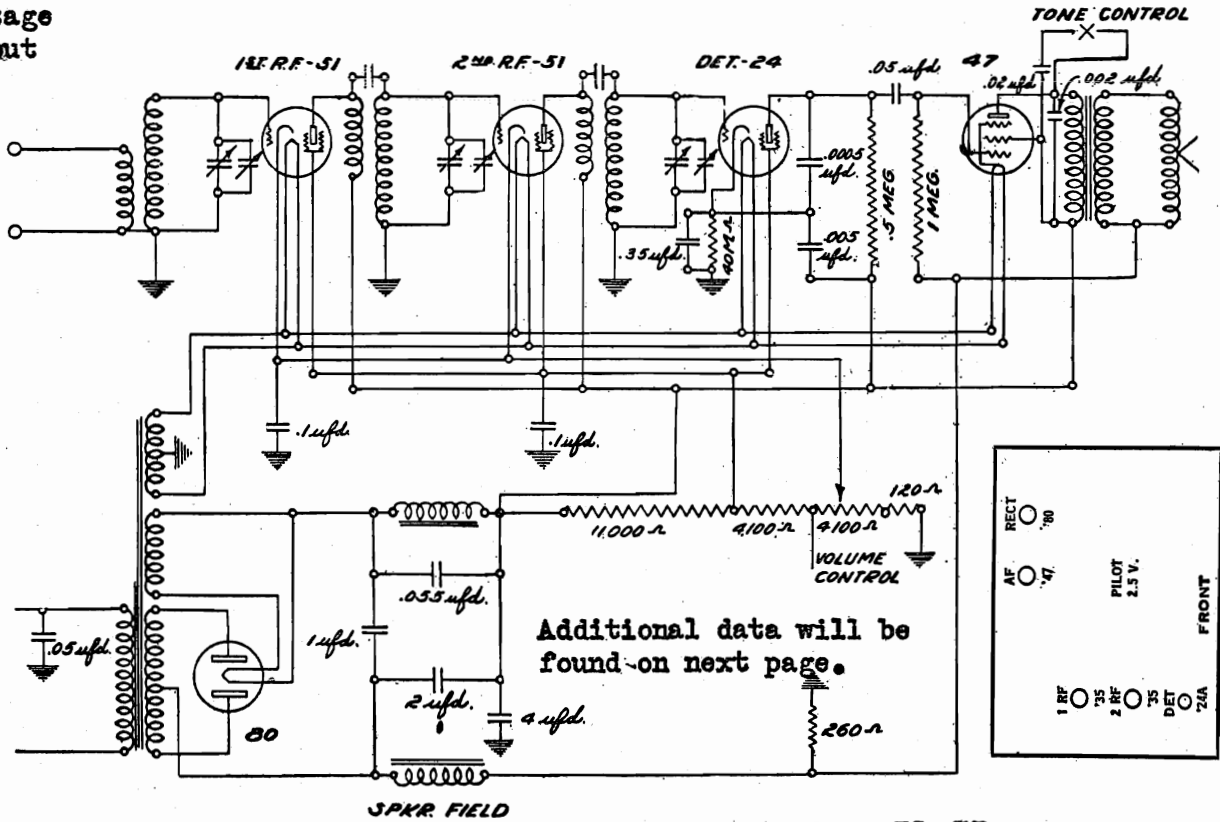

Additional data will be found on next page.

MODEL 31-33

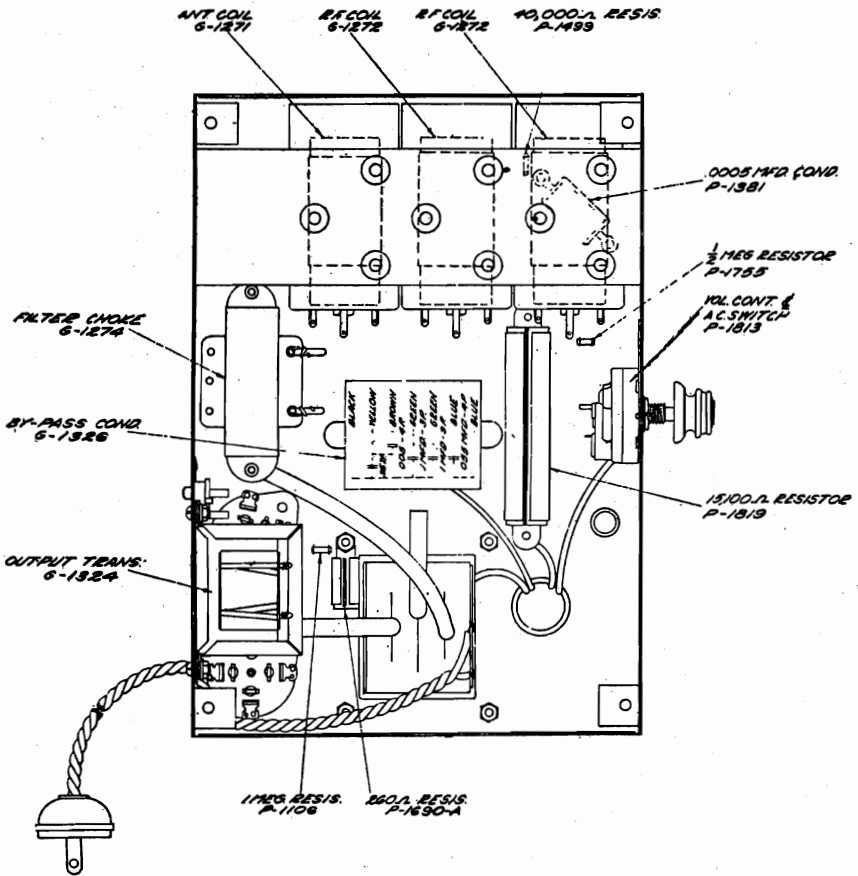

VOLTAGE ANALYSIS
READINGS TAKEN WITH WESTON MODEL 565 ANALYZER

No.	Stage	Type Tube	Fil. Volts	Plate Volts	Cont. Grid, Volts	Cath. Volts	S. G. Volts	Ip. Normal
1	1st R. F.	C. L. 51	2.1	225	2.1	2	75	5
2	2nd R. F.	C. L. 51	2.1	230	2.2	2	75	4.5
3	Det.	C. L. 24	2.1	160*	7	7.5	75	.02
4	Output	C. L. 47	2.1	215	5*	0	225†	26.5
5	Rect.	C. L. 80	4.8	280				430

*Reading dependent upon resistance of meter.
†Reading taken for one anode only: 60 milliamperes would be about correct.
Volume control position full. Line voltage 115—60 cycle.

COLUMBIA PHONOGRAPH COMPANY

MODEL 32,34
 Top View
 Bottom View

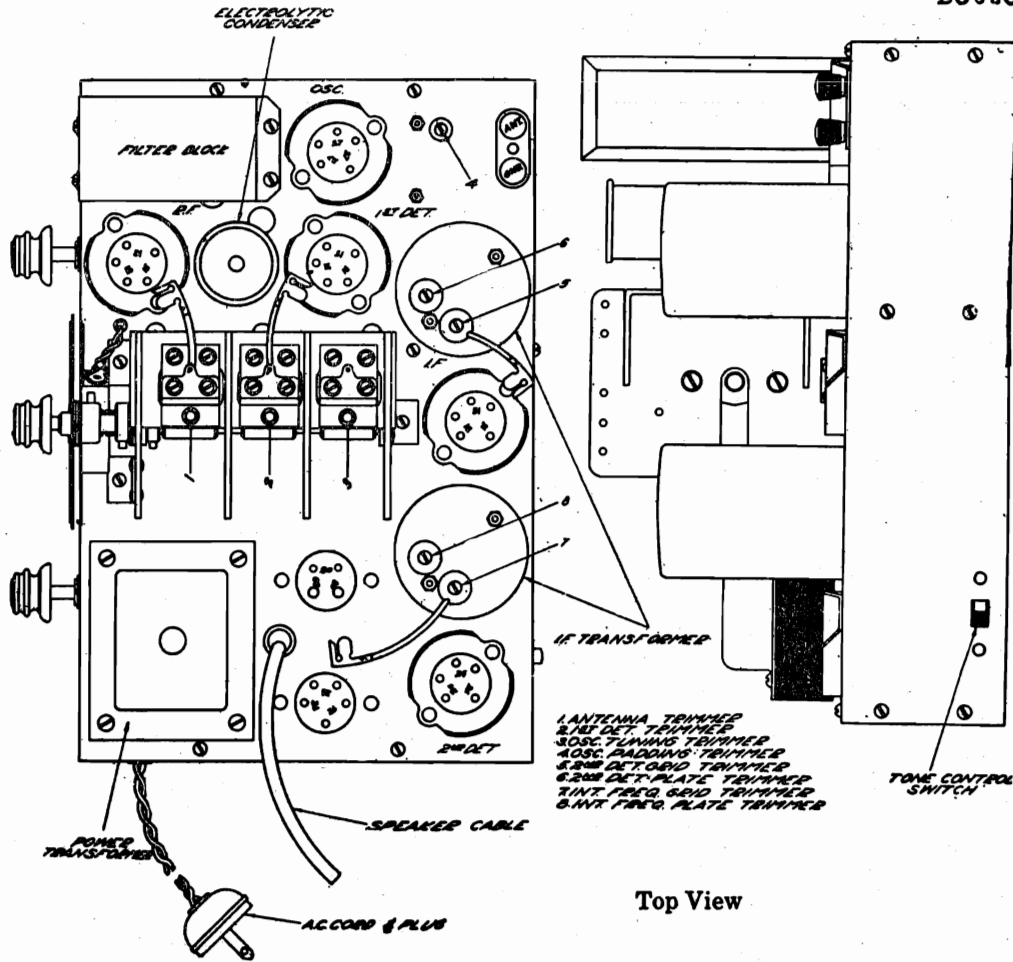

Top View

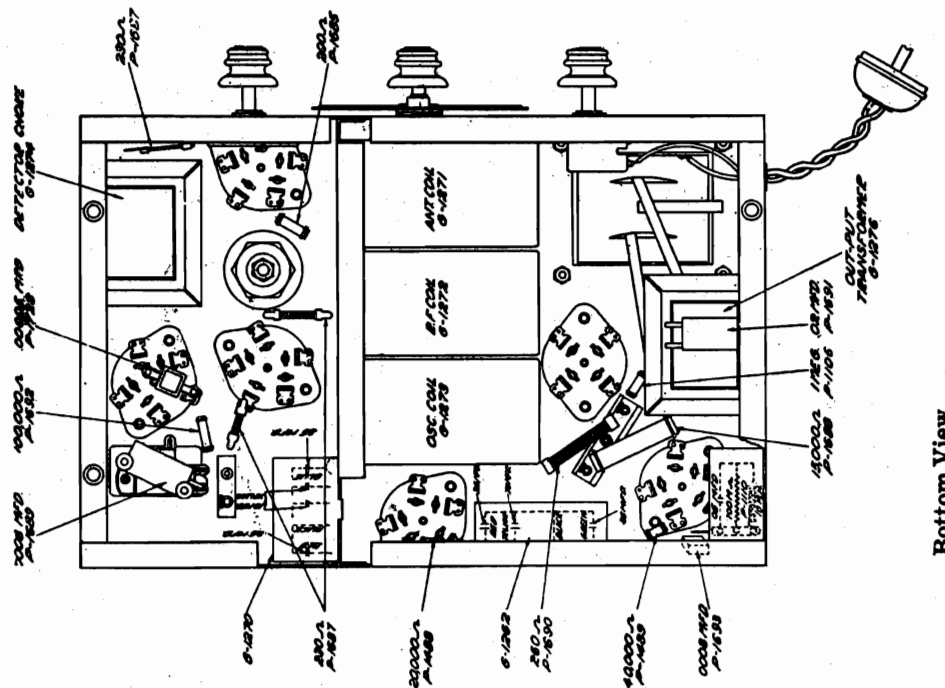

Bottom View

CROSLY RADIO CORP.

MODEL 7
MODEL 7-1
Converters

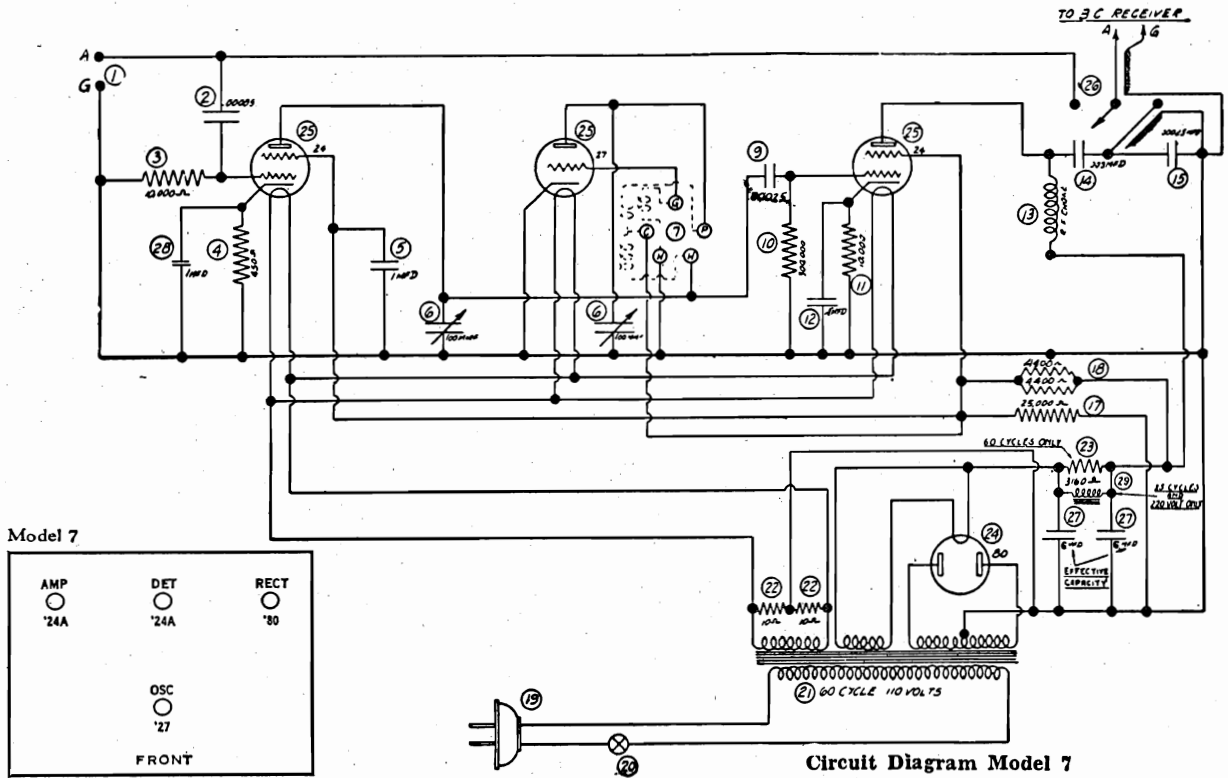

Circuit Diagram Model 7

This is a chassis for attaching to any broadcast receiver in order to adapt the latter to the reception of short-wave signals. It is of the superheterodyne type, the incoming signal being converted to a frequency within the regular broadcast range by the use of an oscillator and detector (see Service Bulletin No. A-1 for an explanation of the superheterodyne receiver).

After conversion to the appropriate frequency the signal is delivered to the aerial and ground terminals of the broadcast receiver.

The chassis incorporates a -24 type, untuned buffer amplifier, a -27 tuned oscillator, a -24 tuned detector, and a -80 rectifier. Various frequency ranges are obtainable by the use of suitable coils, as explained in the instructions accompanying the chassis.

Model 7-1

Model 7-1 is a short-wave converter similar in general operation to Model 7, which has been described previously, but incorporating one less tube and having a tuned antenna circuit.

The tubes are as follows: a -24 first detector, a -27 oscillator, and a -80 rectifier.

Model 7-1

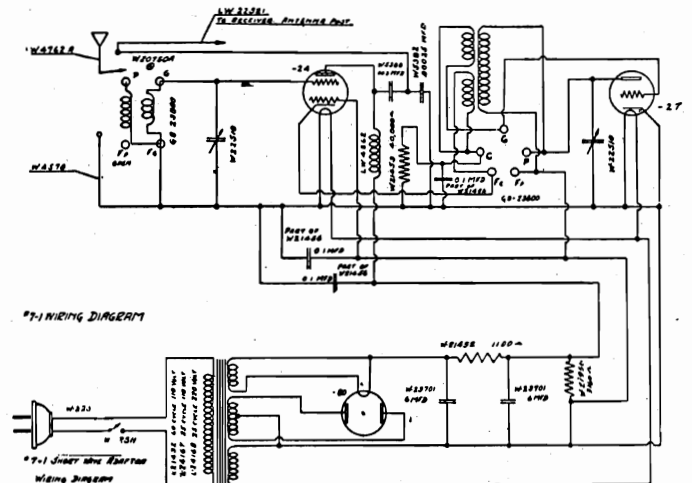
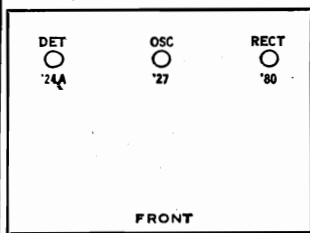

Circuit Diagram, Model 7-1

MODEL 26
Schematic, Voltage
Parts List

CROSLY RADIO CORP.

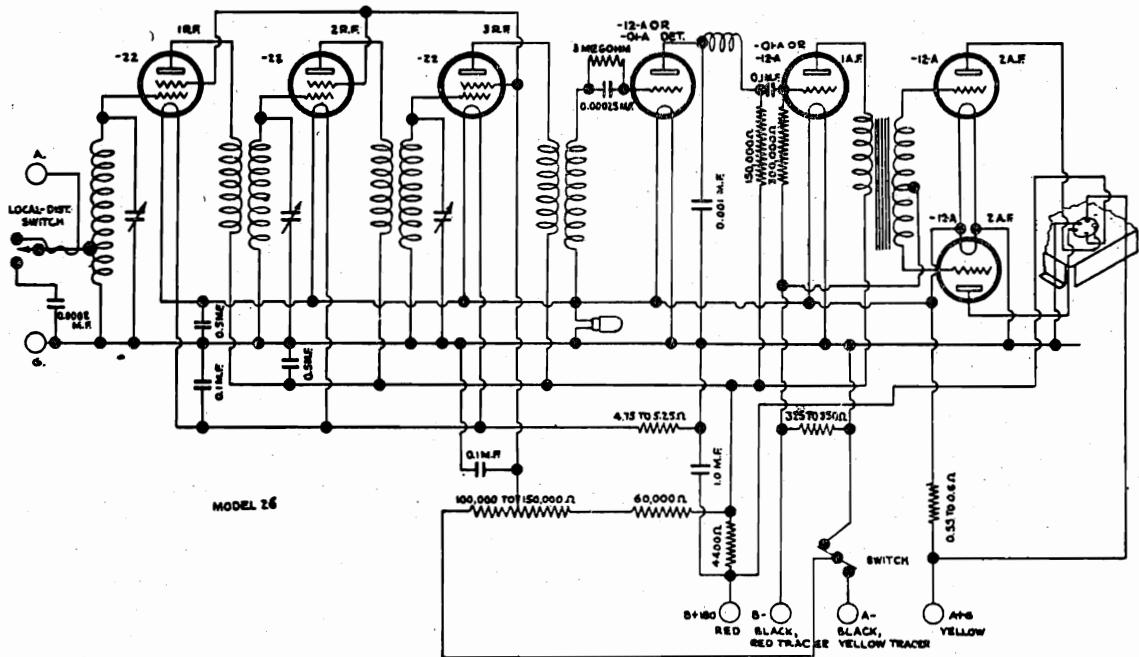

Qty.	Part No.	Description
1	W-4968	.5 Mfd. Fixed Condenser (2 paper)
1	W-0614	R. F. Choke
1	W-7753	.1 - .5 - .1 Mfd. Fixed Cond.
1	W-4013	1. Mfd. Fixed Condenser
1	W-20820	Mounting Strip
1	W-4924	.00025 Mfd. Fixed Condenser
1	W-5468	3 Meg. (Grid Leak) Resistor
1	W-4923	60000 Ohm Resistor (Blue, Orange Spot)
1	W-6754	.001 Mfd. Fixed Condenser
1	W-20820	Mounting Strip
1	W-7150	4400 Ohm Resistor (Yellow, Red Spot)
1	W-5785	150000 Ohm Resistor (Brown, Green, Yellow Spot)
1	W-4302	Plate Choke
1	W-6471	.1 Mfd. Fixed Condenser (2 paper)
1	W-5713	Mounting Strip
1	W-0704	300000 Ohm Resistor, (Brown, Blk., Yellow Spot)
1	W-20090	.55 to .6 Ohm Resistor
1	W-20100	350 Ohm Resistor

Filament Voltages

R. F. tubes	2.4 to 2.7
Detector, 1st Audio, and Output tubes	4.3 to 4.8

Plate Voltages

R. F. and 1st Audio tubes	120 to 130
Detector tube	110 to 120
Output tubes	150 to 160

Control Grid Voltages

R. F. tubes	1.6 to 2.0
Detector tube	4.3 to 4.6
1st Audio and Output Tubes	4.3 to 4.6

Screen Grid Voltages

R. F. tubes	48 to 55
-------------	----------

The above voltages are to be measured with the speaker connected

Models 26H, 26J, 26K

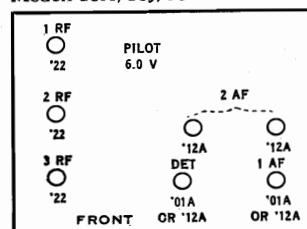

CROSLLEY RADIO CORP.

MODEL 28, 27
Schematic, Voltage
Notes

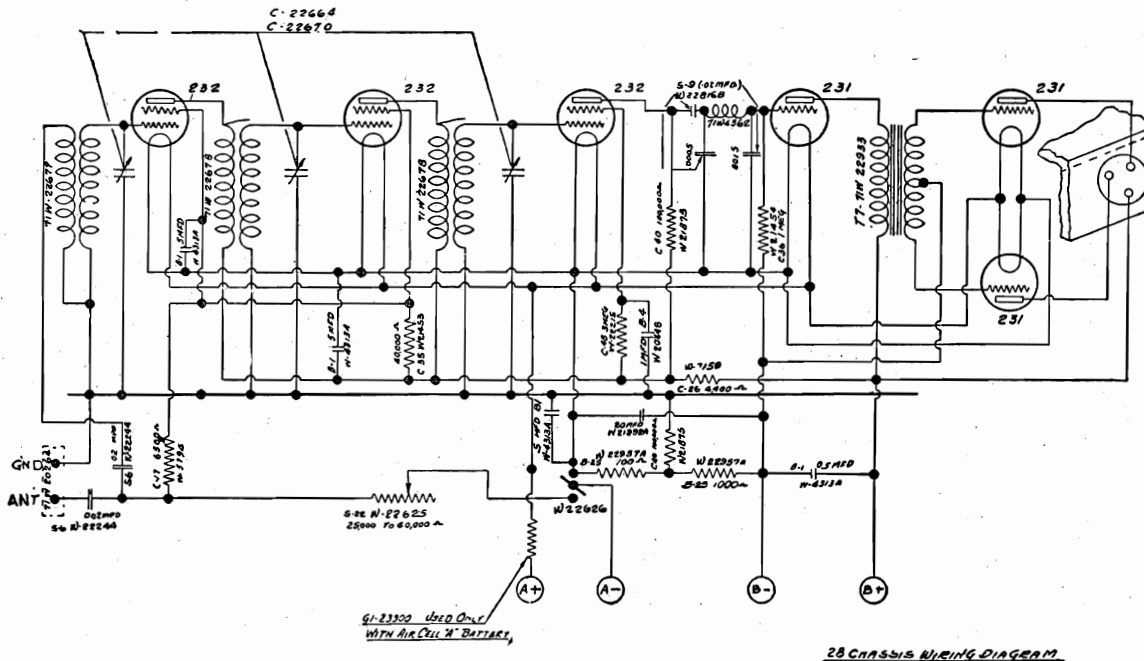

—Circuit Diagram, Model 28.

Specifications

Models 27 and 28 are battery receivers identical in circuit and electrical design but differing in mechanical construction. They are six tube receivers, incorporating two -32 r. f. amplifiers, a -32 detector, a -31 intermediate audio amplifier, and -31 push-pull output tubes.

The batteries used are a 2 volt Eveready Air Cell or 2 volt storage battery, and four 45 volt "B" batteries.

Installation Notes

An aerial of moderate size will usually be satisfactory.

There is a battery resistor in the "A" battery cable. This should be removed if a storage battery is used instead of the 2 volt Air Cell.

The color code of the battery cable is as follows: Red lead (B+ 180 volts): to +45 terminal of fourth 45 volt "B" battery. Black lead with red tracer (B-): to minus terminal of first 45 volt "B" battery. Black lead with yellow tracer (A-): to minus terminal of Eveready Air Cell or 2 volt storage battery. Yellow lead (A+ 2 volts): to plus terminal of Air Cell or 2 volt storage battery.

When installing the receiver, check the tubes to see that they are inserted in their proper sockets, and make sure that the clip wires are connected to the clips of the screen grid tubes.

Model 28

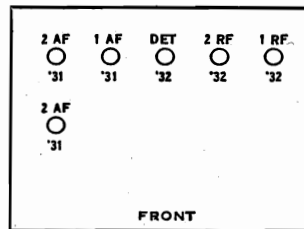

Filament Voltages	
All tubes	1.8 to 2.0
Plate Voltages	
R. F. tubes	120 to 140
Detector tube	50 to 65
First A. F. tube	125 to 160
Output tubes	130 to 160
Control Grid Voltages	
R. F. and detector tubes	2 to 3.5
First A. F. and output tubes	20 to 28
Screen Grid Voltages	
R. F. tubes	55 to 70
Detector tubes	15 to 22
Plate Current	
R. F. tubes	0.0022 to 0.0025
First A. F.	0.005 to 0.0065
Output tubes	0.007 to 0.0085
Screen Grid Current	
R. F. tubes	0.00055 to 0.0007

CROSLY RADIO CORP.

MODEL 59 AC
Voltage, Notes
Parts List

MODEL 59 AC

Voltage Limits

Filament Voltages	
All tubes but rectifier	2.3 to 2.4
Rectifier tube	4.5 to 4.9
Plate Voltages	
R. F. Amplifiers	240 to 280
Detector	160 to 190
Output	230 to 270
Rectifier (A. C. voltage)	290 to 330 each plate
Screen Grid Voltages	
R. F. Amplifiers	55 to 65
Detector	125 to 155
Control Grid Voltages	
R. F. Amplifiers	2.5 to 3.5
Detector	11.0 to 13.0
Output tube	50 to 64

To be measured with speaker connected, volume control on full, and line voltage of 117½ (235 for 220 volt receivers). Measure plate and grid voltages with a high-resistance D. C. voltmeter (600 ohms or more per volt) from plate or grid tube contact to emitter contact. Use a low range A. C. meter for filament voltages.

Specifications

Model 59 is a compact, tuned radio-frequency receiver for operation from 110 volt and 220 volt A. C. house-lighting circuits. It is supplied in several cabinet styles in conjunction with Model 299 dynamic speaker.

The ends of the high-voltage secondary are connected to the plates of the rectifier tube, and the middle tap on it is connected to the negative side of the loudspeaker field ("B-"), and through one megohm and 300,000 ohm resistors to ground. The other side of the speaker field ("G") is connected to ground (chassis).

The positive plate supply circuit originates at the rectifier filament. One branch goes to the "B+" speaker terminal, whence it continues through the primary of the speaker output transformer to speaker terminal "P", and thence to the plate of the pentode tube.

A second branch of the B+ circuit goes through a 1100 ohm resistor to the screen grid of the pentode tube, and to the plates and screen grids of the other tubes. It is connected through a 300,000 ohm detector plate coupling resistor to the plate of the detector tube, through the primaries of the second and third radio-frequency transformers to the plates of the r. f. tubes, through a 100,000 ohm resistor to the screen grids of the r. f. tubes, a branch of the circuit returning to the r. f. cathodes through a 300,000 ohm resistor and through an additional resistor of 3 megohms to the screen grid of the detector tube.

The speaker field coil, in connection with two filter condensers—one (effective capacity 6 m. f.) of which is shunted across the speaker field and the other (effective capacity 12 m. f.) of which is connected from B+ to ground—acts as a filter circuit, eliminating hum.

Biasing of the r. f. tubes is accomplished by the volume control resistor. Adjustment of the volume control simultaneously varies the bias of the r. f. tubes and the value of a resistor shunted across the primary of the antenna coil. A 40,000 ohm biasing resistor is used in the detector emitter circuit. Biasing of the audio tube is accomplished by returning the audio grid to the negative side of the 300,000 ohm resistor in the B- circuit, connected to chassis.

Qty.	Part No.	Description	List Price	Qty.	Part No.	Description	List Price
1	D-22669A	Chassis	\$.75	1	W-22329	Dial Light Bracket Assem- bly Less Lamp25
4	W-7873	Socket (5 Prong)30	1	W-22410	Switch75
1	W-7871	Socket (4 Prong)25	1	W-23117	Volume Control	1.25
1	W-21297	Socket Guide (280)10	1	B-22929	Tube Shield Assembly25
1	W-22818	Socket Guide (Pen.)10	PARTS UNDER CHASSIS			
1	W-22819	Socket Guide (224)10	1	W-22995	.5 - .1 Mfd. Fixed Condenser	1.00
2	W-22820	Socket Guide (235)10	1	W-22877	R. F. Transformer (ant)	1.50
1	W-22413	Power Trans. 110 V. 60 Cy.	6.00	2	W-22878	R. F. Transformer (Int.)	1.50
1	W-22866	Power Trans. 110 V. 25 Cy.	6.25	3	W-7558A	R. F. Coil Shields20
1	W-22867	Power Trans. 220 V. 25 Cy.	6.25	1	W-22668	Mounting Plate30
1	W-21459	Mershon Condenser 8 Mfd.	2.50	1	W-21452	Flexible Resistor 1100 Ohms	.25
1	W-21485	Mershon Condenser Socket ..	.25	1	W-23191	.01 Mfd. Fixed Condenser25
1	W-22689A	Mershon Condenser 12 Mfd. ..	3.50	1	W-21453	Fixed Resistance 40000 Ohms	.30
1	W-23147	Insulating Washer05	2	W-21454	Fixed Resistance 1 Megohm	.30
1	W-22664	Tuning Condenser Gang	7.00	1	W-21455	Fixed Resist. 300000 Ohms	.30
3	W-21973	Grid Connectors25	1	W-4362	R. F. Plate Choke50
CONDENSER DRIVE							
1	W-22685	Pulley25	1	W-22417	Potentiometer 10-10 Ohms15
1	W-22334	Drive Cord (39")25	1	W-22816B	.0015 - .02 - .0005 Mfd. Fixed Condenser75
1	W-22682	Idler Bracket Assem. (top)15	1	W-22412	.1 - .1 - .1 - .1 Mfd. Fix. Con.	.75
1	W-22683	Idler Br. Assem. (lower)15	1	W-21454	Fixed Resistance 1 Megohm	.30
1	W-22400A	Drive Pulley Bracket10	1	W-21455	Fixed Resist. 300000 Ohms30
1	W-22827	Drive Shaft30	1	W-21875	Fixed Resist. 100000 Ohms30
1	W-22463	Stop Washer05	1	W-21455	Fixed Resist. 300000 Ohms30
1	W-22828	Stop Washer05	1	W-22395	Speaker Socket25
1	W-22681	Idler Bracket Assem. (Ten.)15	1	W-22397	Insulator05
1	W-22684	Spacer05	1	W-20264	Terminal A & G30
1	W-22464B	Spring05	1	W-21466A	Cable & Plug50
1	W-22879	Dial Strip15				

CROSLY RADIO CORP.

MODEL V
MODEL 2-Step A-F. Amp.
Schematic

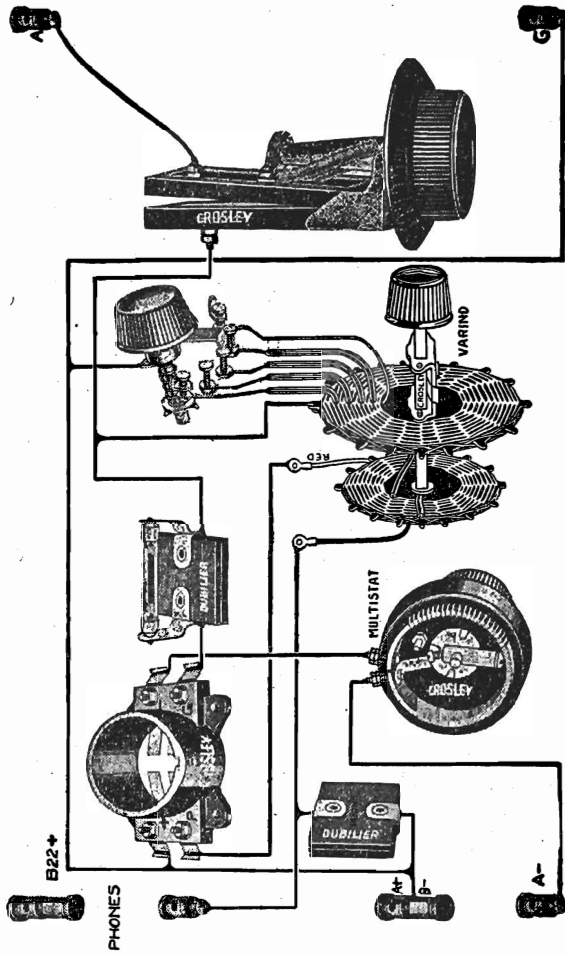

Crosley Type V Single Tube Receiver

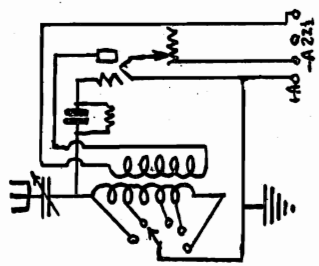

MODEL V

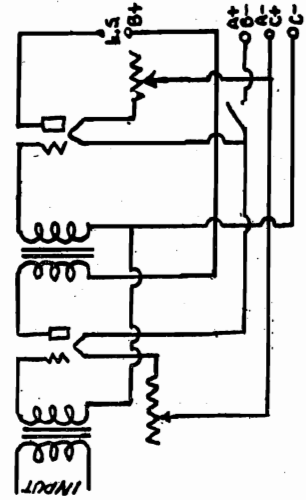

MODEL TWO-STEP A-F. AMPLIFIER

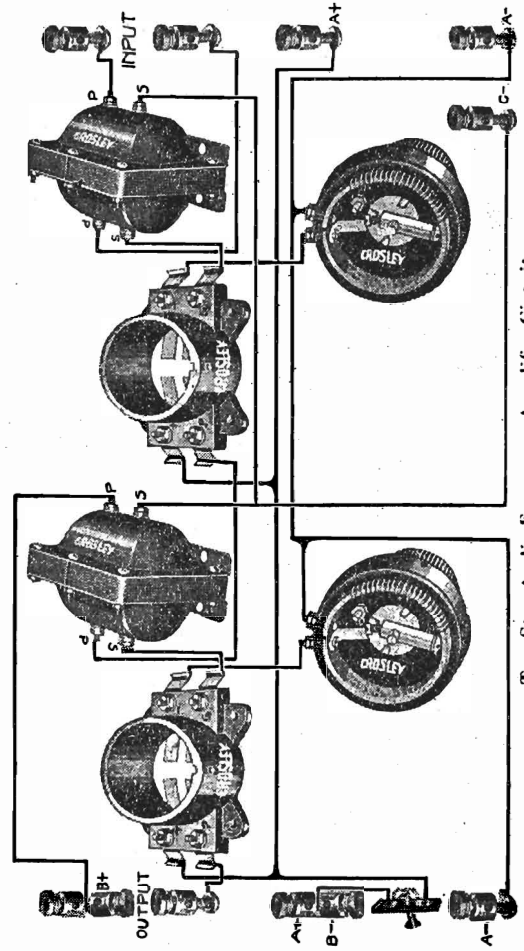

Two-Step Audio Frequency Amplifier Circuit

MODEL 121, SERIES A
MODEL 121, SERIES B
Schematic

CROSLLEY RADIO CORP.

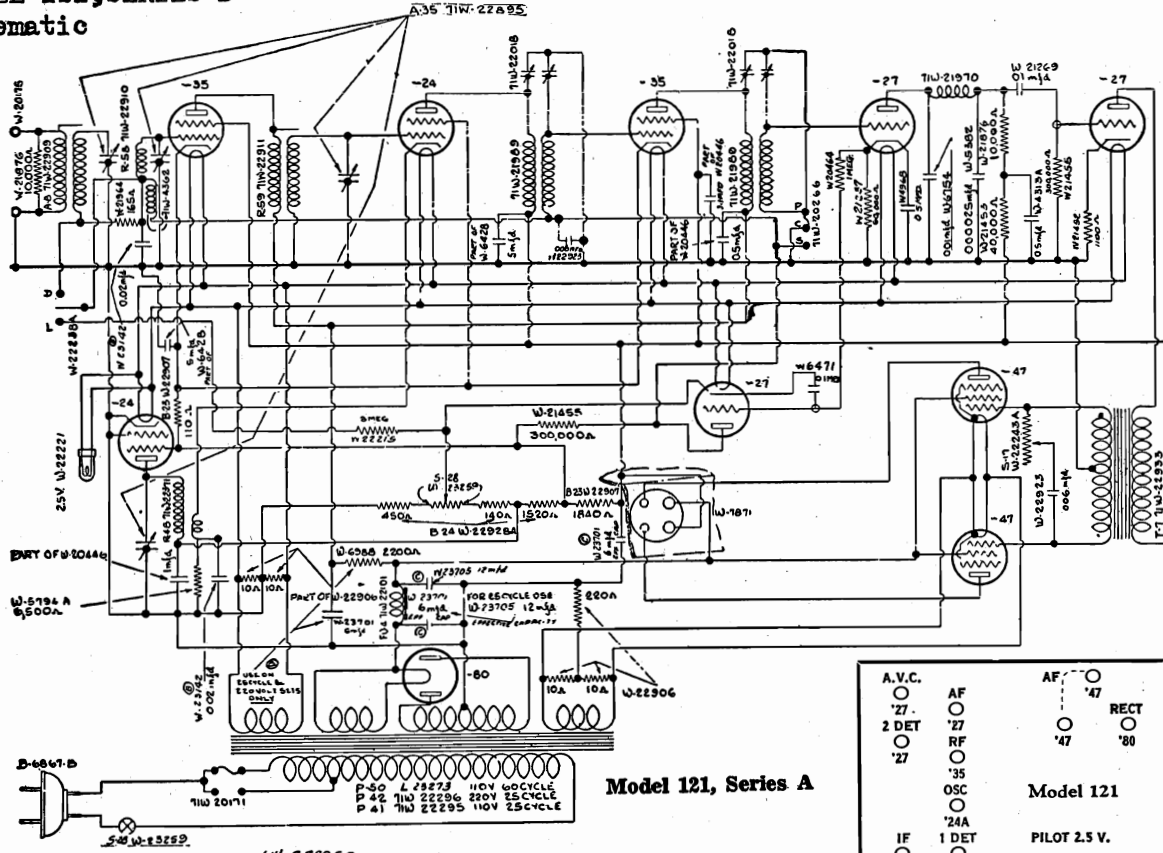

Model 121, Series A

A.V.C.	AF	AF	'47	RECT
'27	'27	'27	'47	'80
2 DET	RF	'47	'80	
'27	'35			
	OSC			
	'24A			
IF	1 DET			PILOT 2.5 V.
'35	'24A			FRONT

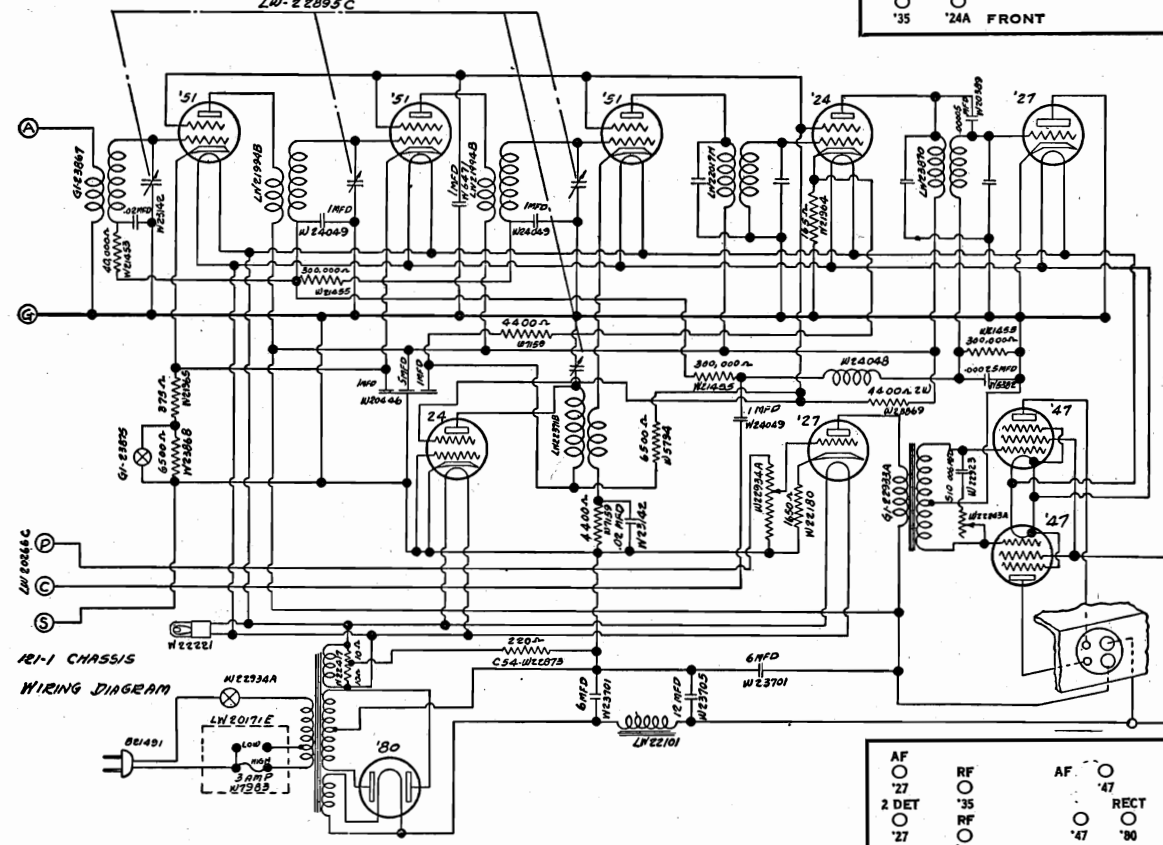

121-1 CHASSIS WIRING DIAGRAM

Circuit Diagram, Model 121, Series B

AF	RF	AF	'47	RECT
'27	'35	'47	'80	
2 DET	RF	'47	'80	
'27	'35			
	OSC			
	'24A			
IF	1 DET			2.5 V. PILOT
'24A	'35			FRONT

CROSLY RADIO CORP

MODEL 122
Schematic, Voltage

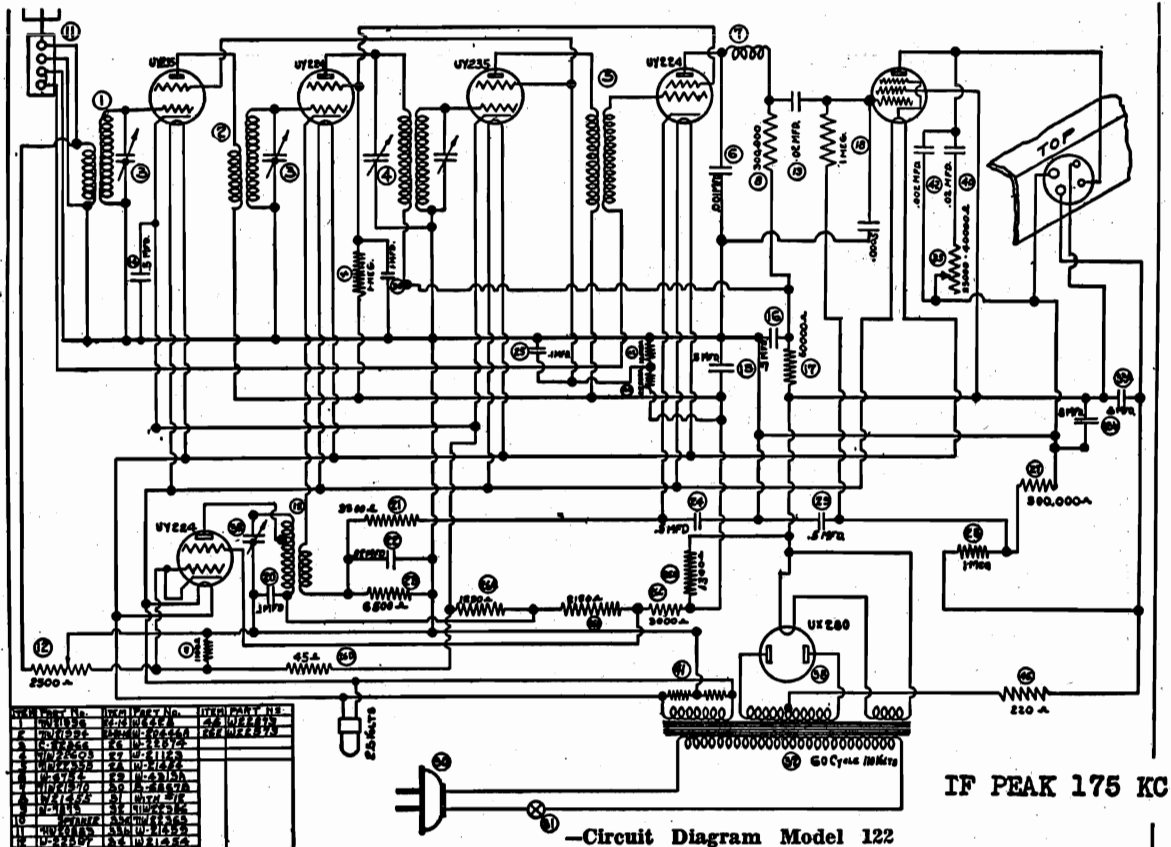

NOTE: Item 43 in above parts list should be No. W21876,
Item 44 should be No. W5370, Item 26 E should be W22996

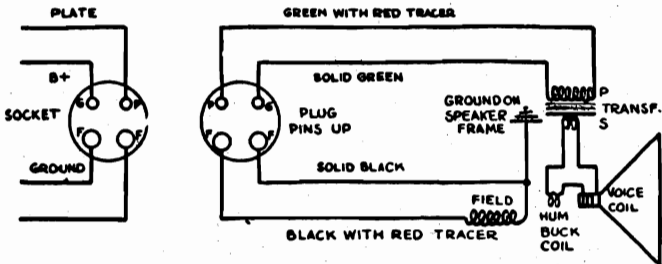
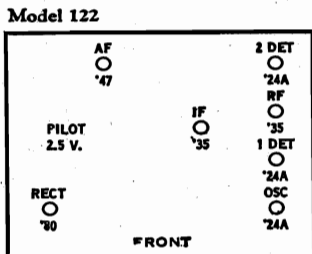

SPEAKERS 297 AND 305-J FOR CHASSIS 122

Filament Voltages	
All tubes but rectifier	2.3 to 2.5
Rectifier tube	4.6 to 5.0
Plate Voltages	
1st R. F. and Intermediate Amplifiers	170 to 300
Oscillator	28 to 38
1st Detector and 2nd Detector	185 to 215
Output	260 to 300
Rectifier (A. C. voltage)	280 to 320
	each plate
Screen Grid Voltages	
1st R. F. and Intermediate Amplifiers	45 to 55
1st Detector and 2nd Detector	60 to 80
Oscillator	80 to 100
Output	260 to 300
Control Grid Voltages	
1st R. F. and Intermediate Amplifiers	1.5 to 2.5
1st Detector	6.0 to 8.0
2nd Detector	8.0 to 10.0
Output tube	18.0 to 22.0

To be measured with speaker connected, volume control on full, and line voltage of 117½ (235 for 220 volt receivers).

For Alignment, Changes and Chassis Data see next page

MODEL 123
Schematic, Voltage

CROSLY RADIO CORP.

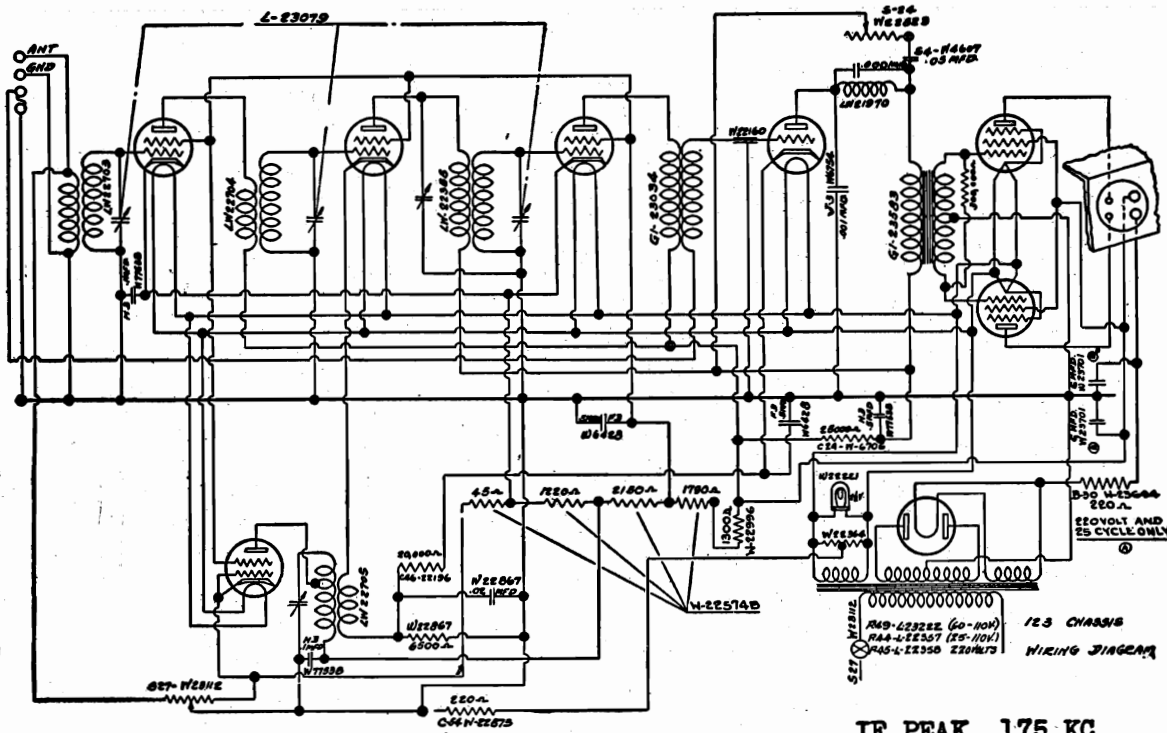

-Circuit Diagram Model 123

IF PEAK 175 KC

Voltage Limits

Filament Voltages	
R. F., First Detector, Oscillator and Second Detector	2.2 to 2.4
I. F. Amplifier	2.2 to 2.5
Output	2.3 to 2.6
Rectifier	4.9 to 5.3
Plate Voltages	
R. F. and I. F. Amplifiers	215 to 245
First Detector	170 to 190
Oscillator	32 to 42
Second Detector	160 to 180
Output	190 to 230
Rectifier, D. C. voltage	290 to 330
Screen Grid Voltages	
Oscillator, R. F. and I. F. Amplifiers	90 to 110
First Detector	80 to 100
Output	200 to 240
Control Grid Voltages	
R. F. and I. F. Amplifiers	1.5 to 2.5
First Detector	7 to 9
Second Detector	18 to 22
Output	13 to 16

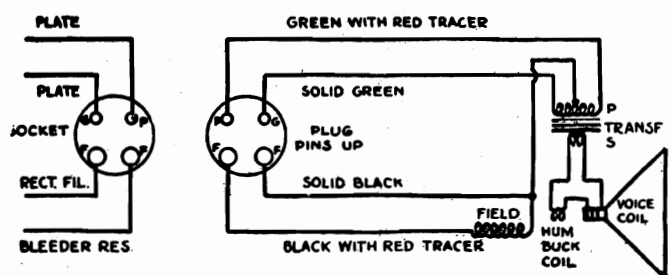
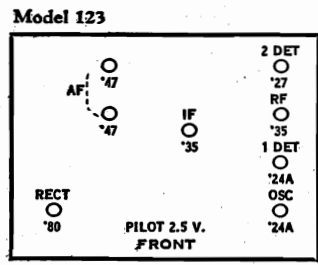

SPEAKER 287 FOR CHASSIS 123:

CROSLY RADIO CORP.

MODEL 124
Schematic
Voltage

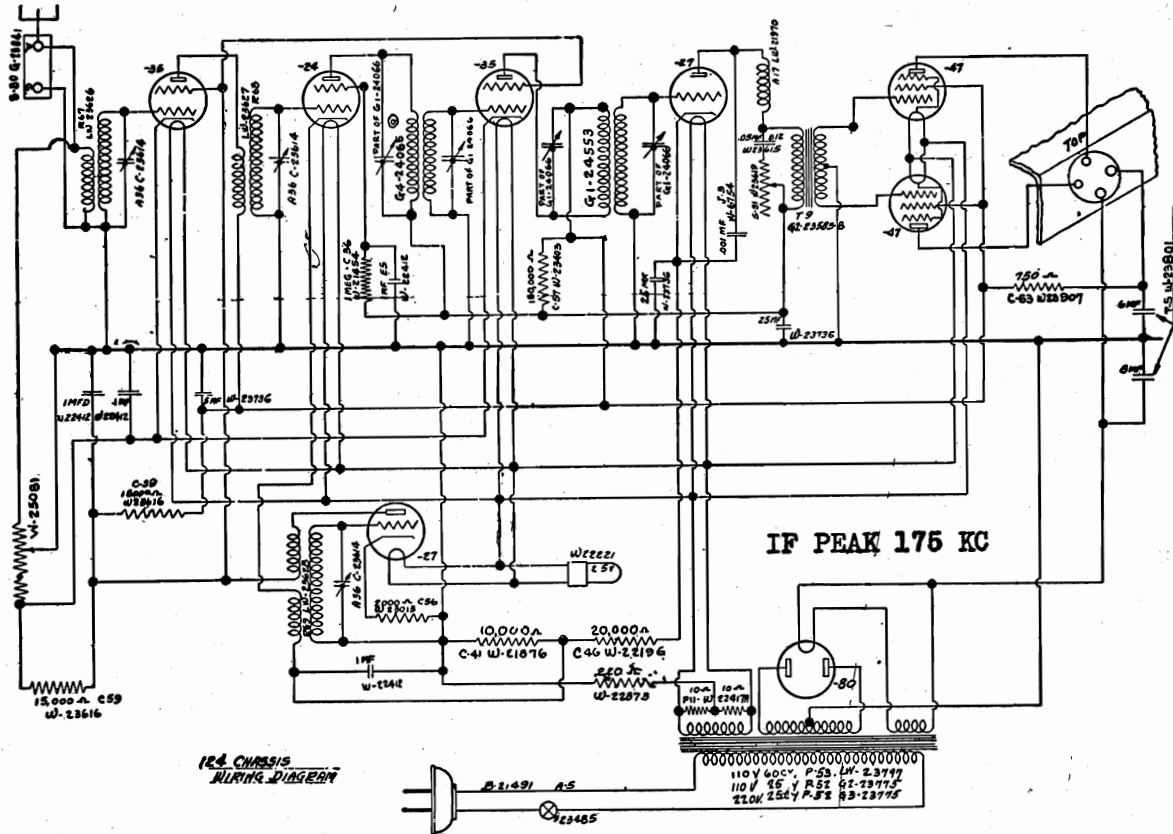

Model 124 Circuit

Model 124

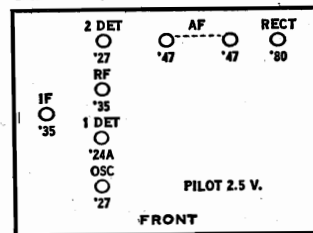

Voltage Limits

Filament Voltages	
All tubes but rectifier	2.3 to 2.5
Rectifier	4.6 to 5.0
Plate Voltages	
R. F. and I. F. Amplifiers and Output	235 to 265
First and Second Detectors	170 to 190
Rectifier, D. C. Voltage	60 to 80
300 to 340	
Screen Grid Voltages	
R. F. and I. F. Amplifiers	80 to 100
First Detector	55 to 65
Output	230 to 270
Control Grid Voltages	
R. F. and I. F. Amplifiers	1.5 to 2.5
First Detector and Oscillator	7 to 9
Second Detector	18 to 22
Output	15 to 18

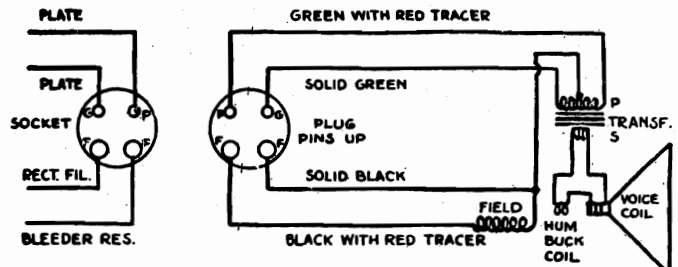

For Alignment Data refer to similar information pertaining to Model 122.

Speakers 306-J and 306-M for Chassis 124

MODELS 122, 123, 124
Condenser Notes

CROSLLEY RADIO CORP.

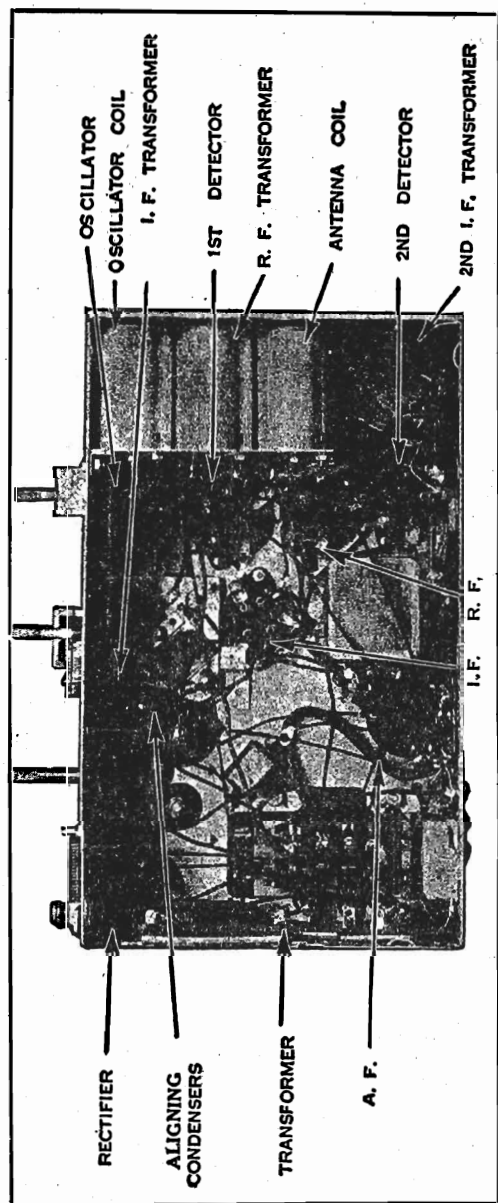

Bottom View, Model 122 Chassis

Changes In Model 122

The following changes as compared with the circuit diagram shown herein will be found in some chassis.

1. The pentode grid resistor is 300,000 ohms instead of 1 megohm as shown on the diagram.
2. The volume control resistor is 650 ohms instead of 2500 ohms, as shown.
3. The 3,000 ohm resistor shown on the diagram just to the left and above the power transformer is changed to 1790 ohms.
4. The 1100 ohm resistor shunted across a portion of the volume control is deleted.
5. The 25,000 ohm resistor in the r. f. screen grid circuit is replaced by a 20,000 ohm resistor.

MODELS 122, 123, 124**Alignment of Tuning Condensers and Intermediate-Frequency Amplifier**

The procedure for aligning the tuning condensers is as follows:

1. Tune to a signal between 1300 and 1400 kilocycles.
2. Turn the volume control all of the way on. If all signals within the required range are too loud, connect a 0.00025 m. f. fixed condenser between the "A" and "G" terminals, and then couple the antenna very loosely to a wire connected to the "A" terminal.
3. If, when carefully tuned to the middle of the band, the dial reading does not correspond to the frequency of the signal, but is not more than two channels off, set the dial at the correct frequency, and adjust the padding condenser on the oscillator tuning condenser (the tuning condenser nearest the front of the chassis) until the signal is loudest. Check the tuning by re-adjusting the station selector. It may not be possible to regulate the oscillator padding condenser so that the oscillator condenser is properly aligned with the exact dial setting, in which case align the padding condenser with a dial setting as close to the actual frequency as practicable.
4. After aligning the oscillator padding condenser, re-tune to a frequency between 1300 and 1400 kilocycles and carefully adjust the padding condensers on the other two tuning condensers until the signal is received with greatest volume.

Aligning Intermediate Frequency Stages

The primary and secondary circuits of the intermediate amplifier transformer must be tuned accurately to 175 kilocycles. They are aligned carefully at the factory, and no change should be necessary. In order to align them an accurately tuned local oscillator operating at 175 kilocycles is essential. The procedure is as follows:

1. A local oscillator tuned accurately to 175 kilocycles frequency is required.
2. Remove the oscillator tube from the chassis. Remove the clip wire from the first detector tube. Connect the test oscillator output from the first detector grid to ground, and adjust the two screws at either side of the front I. F. coil for maximum reading on the output meter. Always re-align the tuning condenser after aligning the I. F. amplifier.

MODEL 125
Schematic
Voltage

CROSLY RADIO CORP.

MODEL 125 SUPERHETERODYNE

Model 125

PEAK FREQ. 175 KC.

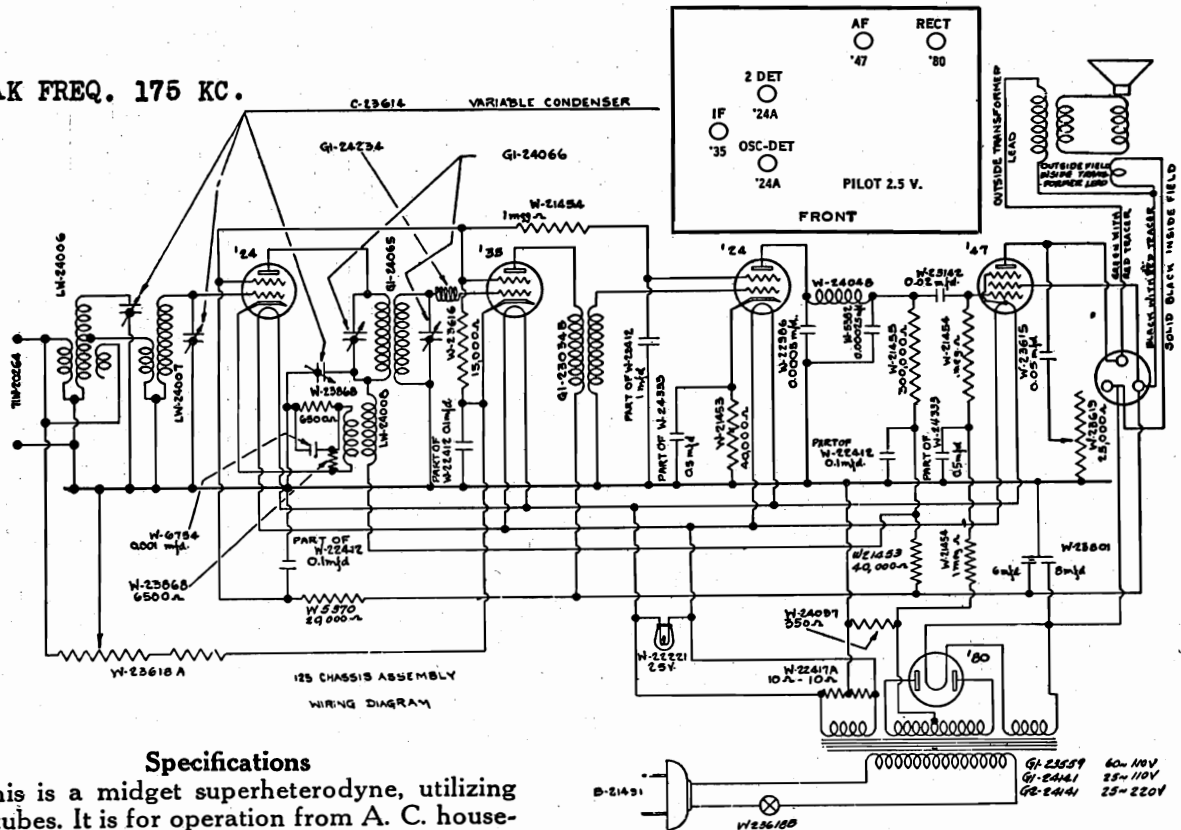

Circuit Diagram, Model 125.

Specifications

This is a midget superheterodyne, utilizing five tubes. It is for operation from A. C. house-lighting circuits, 110 volts 60 cycles, 110 volts 25 to 50 cycles, or 220 volts 25 to 60 cycles.

Instead of being coupled directly to the first tube, as in other Crosley models, the antenna-ground system is coupled to the detector-oscillator through a double tuned selector circuit. This increases the selectivity of the circuit.

The first tube acts both as a detector and oscillator. The oscillator circuit is tuned by a variable condenser—one of the three comprising the station selector gang—as shown on the diagram. The other two station selector condensers tune the grid circuit of the detector-oscillator and the pre-selector circuit.

The detector-oscillator is coupled to the intermediate frequency amplifier stage by an I. F. transformer, both primary and secondary of which are tuned to 175 kilocycles by small adjustable condensers shunted across them. These circuits must be tuned accurately to 175 kilocycles for efficient operation. A radio-frequency choke is in the grid circuit of the I. F. tube.

The timing condenser adjustments are made from the top of the chassis through the three holes in the condenser shield; the I. F. transformer adjustments through the holes at the left side of the chassis, near the front, as viewed from the front of the receiver.

Voltage Limits

The following data shows the average voltages which will be obtained when measurements are made on Model 125 Chassis using a voltmeter of 1000 ohms resistance per volt. Some of these voltages do not represent actual voltages present at the tube elements. A typical example of this is the grid voltage of the pentode tube, which is actually about 16 volts, but only shows about 1 volt when measured in this way.

Screen Grid Voltages

- Pentode ..200 to 230
- I. F. 75 to 95
- 1st Det. . 75 to 95
- 2nd Det. 15 to 25 (250V scale), 3-8 (50V scale)

Plate Voltages

- Pentode 200 to 230
- I. F.200 to 230
- 1st Det. ..160 to 180
- 2nd Det. 75 to 90 (250V scale), 20-30 (50V scale)

Control Grid Voltages

- Pentode ..0.5 to 1.5
- I. F.1.5 to 2.5 (20-30 vol. cont. off)
- 1st Det. ..5.5 to 7.5
- 2nd Det. ..4.0 to 6.0

Filament Voltages

- All tubes but rectifier2.3 to 2.5
- Rectifier tube4.5 to 5.0

MODEL 126
MODEL 126-1
Schematic

CROSLLEY RADIO CORP.

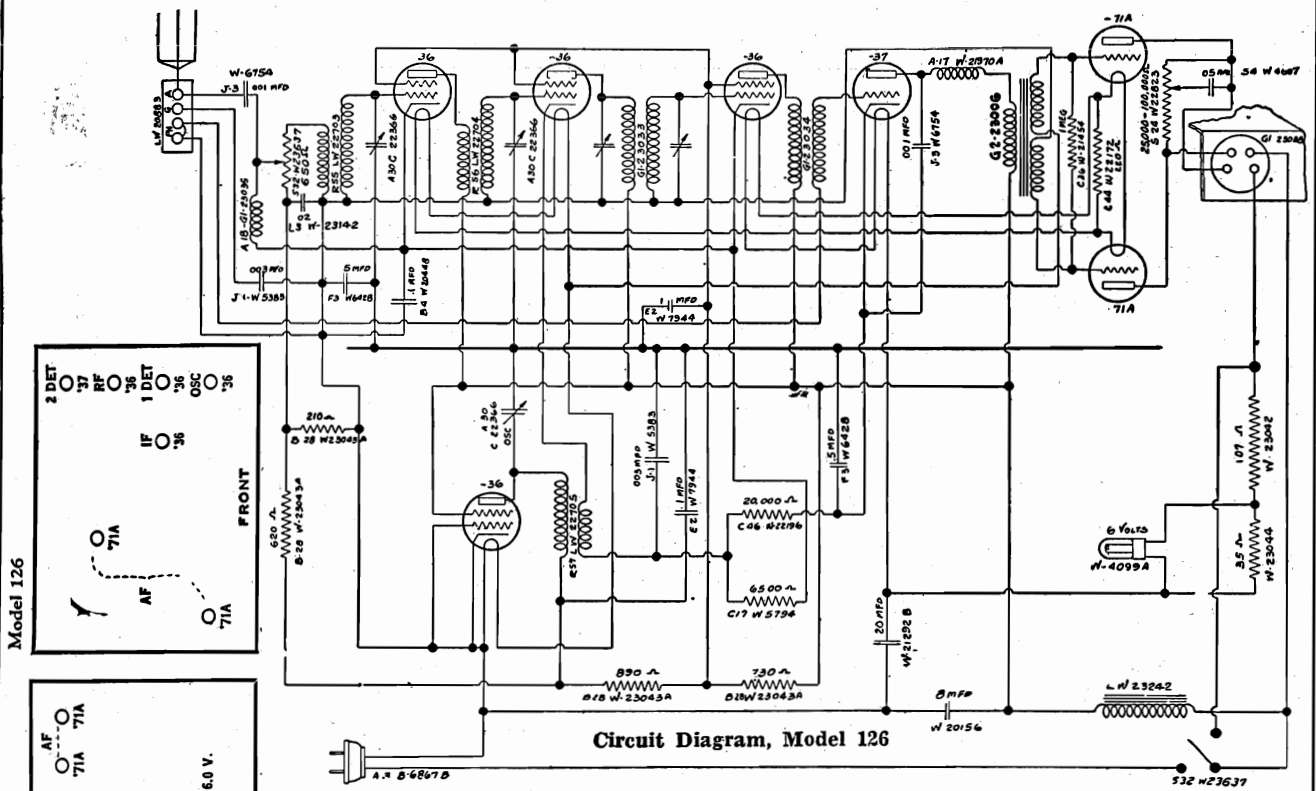

IF PEAK 175 KC

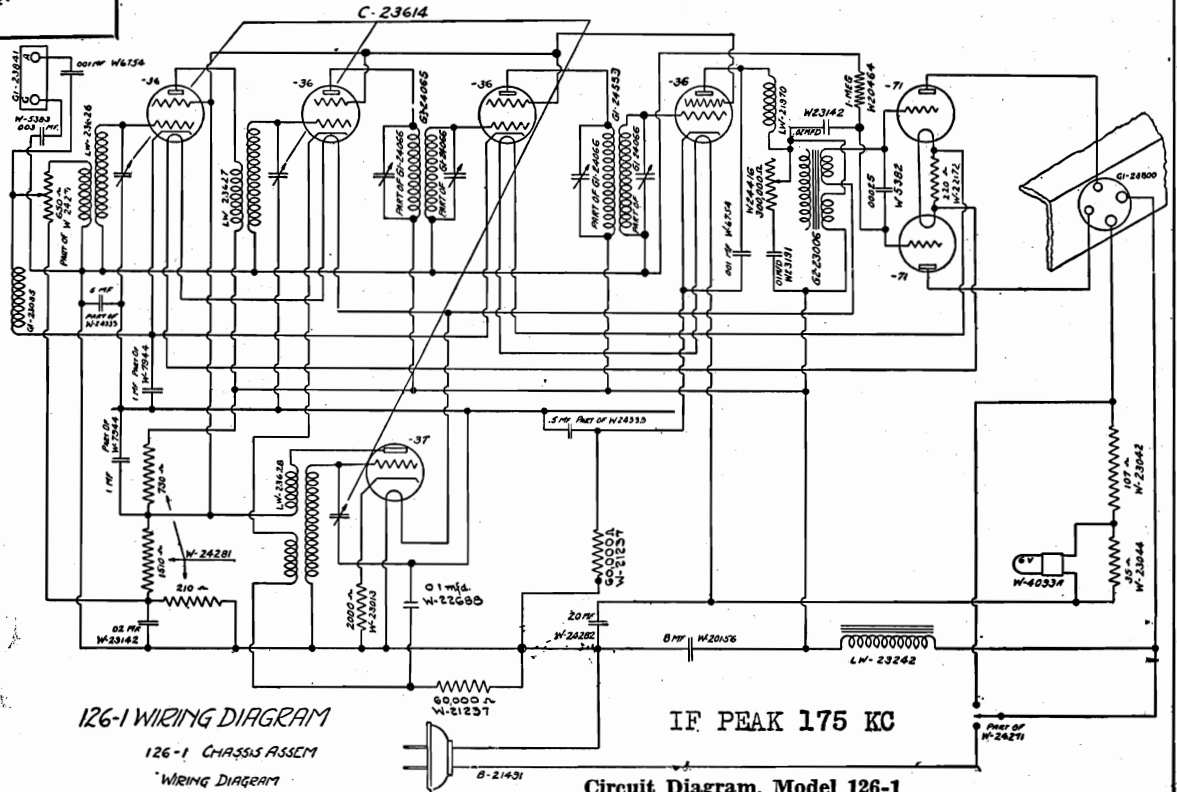
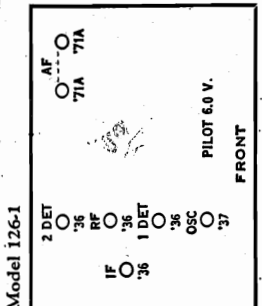
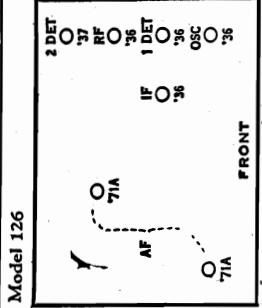

IF PEAK 175 KC

Circuit Diagram, Model 126-1

CROSLY RADIO CORP.

MODEL 127
Schematic
Voltage
Notes

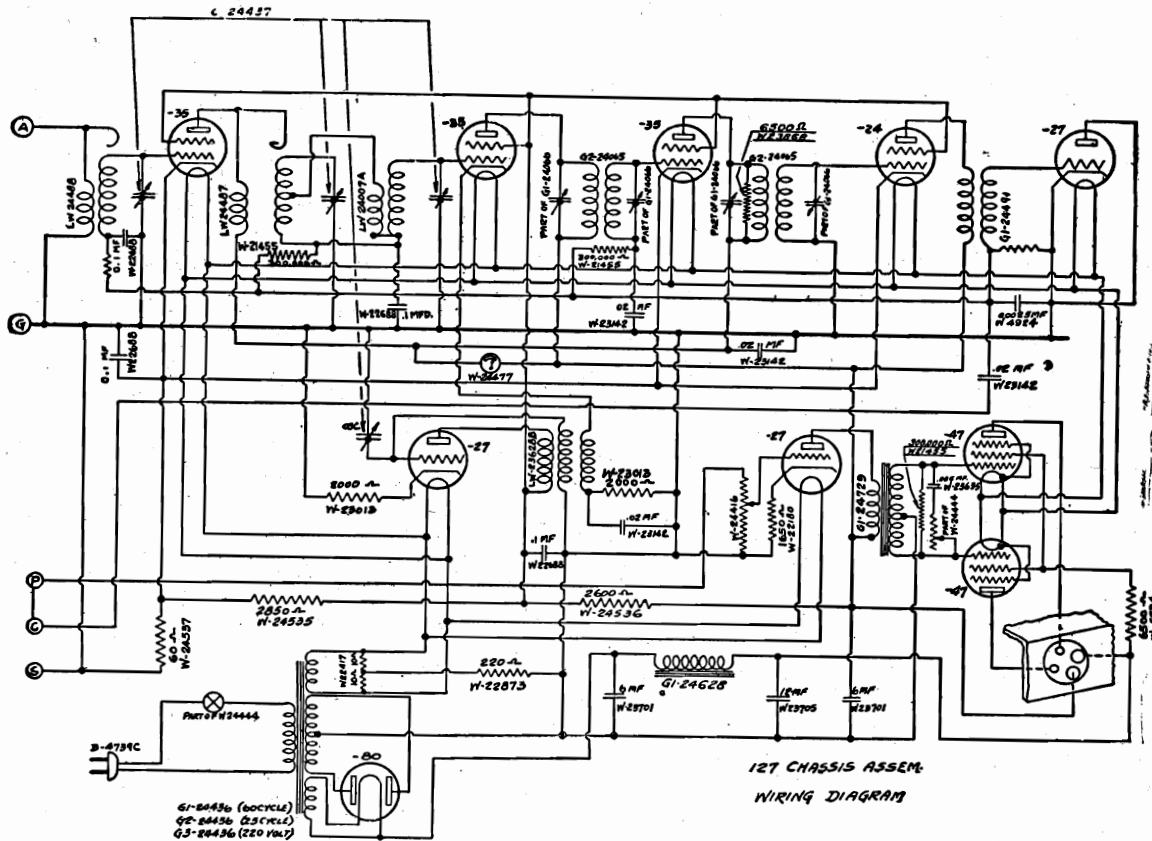

-Circuit Diagram, Model 127.

IF PEAK 175 KC

See Next Page

Voltage Limits

To be measured with tubes in place, speaker connected, and line voltage of 117½ (235 for 220 volt receivers).

Filament Voltages	
All tubes but rectifier	2.3 to 2.5
Rectifier tube	4.6 to 5.0
Plate Voltages	
All tubes but second detector and pentodes	170 to 200
Second detector	0
Pentode output tubes	270 to 300
Screen Grid Voltages	
All screen grid tubes but pentodes	75 to 95
Pentode output tubes	230 to 250
Control Grid Voltages	
R. F. and I. F. amplifiers	2.5 to 3.5
First detector	6 to 10
Oscillator	8 to 12
First A. F. amplifier	8 to 12
Pentode output tubes	14 to 18

Model 127

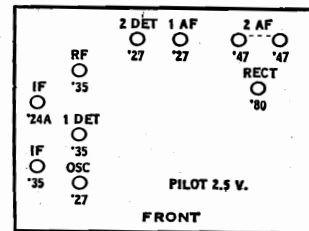

Hum Adjustment

With properly matched output tubes, the hum level of this chassis is very low. The audio transformer shield may be rotated, after loosening the three hold-down screws, and so adjusted that the hum is reduced to a minimum. This adjustment is made at the factory and should not have to be made in the field unless it is necessary in servicing the receiver to loosen or remove the audio transformer shield. If the receiver hums, try other tubes in the output before attempting to adjust the transformer shield.

MODEL 127
Parts Lists
Notes

CROSLLEY RADIO CORP.

60 cycle, or 220 volt 25 to 60 cycle circuits. The tubes used are as follows: a -35 or -51 radio-frequency amplifier, a-35 or -51 first detector (-24 tubes were used for the first detectors in the earlier chassis of this series, a -27 oscillator, a -35 or -51 first intermediate-frequency amplifier, a -24 second intermediate-frequency amplifier, a -27 diode second detector and automatic volume control tube, a -27 audio-frequency amplifier, two PZ or -47 pentode push-pull output tubes, and a -80 rectifier.

When installing the receiver, make sure that the tubes are in their proper sockets as shown on the connection diagram in the instructions, being particularly careful to see that the -24, and -35 or -51 tubes are not interchanged.

Three phonograph terminals, marked "P", "C", and "S", are provided for use with Crosley phonograph pick-ups. Before connecting a phonograph pick-up, cut the wire between terminals "P" and "C". If the phonograph pick-up is later disconnected, these terminals should be wired together again.

The second detector is of the diode type, and acts also as an automatic volume control tube.

The antenna coil and the interstage coil between the R. F. stage and the tuned selector circuit are connected so as to introduce a certain amount of capacity coupling as well as inductive coupling, as in previous Crosley Models.

Audio Coupling

The diode detector is resistance coupled to the first audio tube, the coupling resistor serving as a volume control. From the detector grid, the coupling circuit continues through a 0.02 m. f. coupling condenser to phonograph terminal "C", whence it continues through a strap between terminals "C" and "P", not shown in the diagram, and from terminal "P" to one end of the volume control resistor, the other end of this resistor being grounded. Since the emitter of the second detector is also grounded, this completes the detector circuit.

Type -24 Detector in Early Chassis
Earlier series of this chassis used a -24 type first detector tube. Connections were the same throughout, except in the tuned selector circuits between the R. F. and the first detector. The grid circuit of the first detector was connected directly to the chassis, instead of through the 300,000 ohm isolating resistor and 0.1 m.f. by-pass condenser shown on the diagram. The lower end of the interstage coil secondary, coupled to the R. F. plate circuit, was connected directly to the chassis, instead of to the grid circuit of the second detector as indicated here.

Alignment of Tuning Condensers and Intermediate Frequency Amplifier

To align the tuning condensers, the same procedure should be followed as outlined for Model 122, except that there are three, instead of two, condensers in addition to the oscillator condenser to be aligned.

Follow the procedure outlined in the same bulletin for aligning the intermediate amplifier transformers, adjusting all four aligning condensers, one at a time.

Hum Adjustment

With properly matched output tubes, the hum level of this chassis is very low. The audio transformer shield may be rotated, after loosening the three hold-down screws, and so adjusted that the hum is reduced to a minimum. This adjustment is made at the factory and should not have to be made in the field unless it is necessary in servicing the receiver to loosen or remove the audio transformer shield. If the receiver hums, try other tubes in the output before attempting to adjust the transformer shield.

Specifications

Model 127 is a compact, ten tube super-heterodyne chassis. It is for operation from A. C. house-lighting circuits, and may be obtained for 110 volt 25 to 50 cycle, 110 volt

Parts List—Model 127

Qty.	Parts No.	Description	List Price Each
1	D-2442A	Chassis	.80
1	G1-23800	Four Prong Socket (Spk.)	.15
1	G2-23800	Five Prong Socket (24)	.15
3	G3-23800	Five Prong Socket (27)	.15
3	G4-23800	Five Prong Socket (35)	.15
2	G5-23800	Five Prong Socket (47)	.15
1	G6-23800	Four Prong Socket (80)	.05
1	G1-23829	Cond. Bracket Assy.	.10
1	LW-20286C	Terminal Board (P. C. S.)	.10
1	LW-20284D	Terminal Board (A & G)	.05
1	LF-24393	Junction Block	3.75
1	LW-24446	R. F. Coil Group Assy.	.60
1	LW-24488	Antenna Coil Assy.	.80
1	LW-24487	Interstage Coil Assy.	.75
1	LW-23628B	Oscillating Coil Assy.	.75
1	LW-24007A	Shield Assy.	.15
1	LW-22374	Mounting Plate	.10
1	C-24447	Variable Condenser	5.50
1	G2-23623	Tube Connection Assy.	.05
1	W-22921	Dial Lamp	.15
1	C-24440	Bottom	.15
1	LW-23600	Light Bracket Assy.	.15
1	G1-23680	Dial Drive Assy.	.50
1	G1-24430	Power Transformer (60 Cy. 110 V.)	5.00
1	G2-24430	Power Transformer (25 Cy. 110 V.)	6.50
1	G3-24430	Power Transformer (25 Cy. 220 V.)	6.50
2	LW-22302	Tube Shield Assy.	.15
2	G2-24045	I. F. Coil Assy.	.60
1	G1-24066	I. F. Condenser Assy.	.30
1	W-24491	I. F. Coil	.30
1	W-24416	Volume Control	.70
1	W-24444	Tone Control & Switch	1.00
1	B-4789C	Cable	.30
1	W-24511	Shield	.05
1	W-24477A	Panel Meter	2.00
1	G1-24628	Filter Choke Assy.	1.25
1	W-24476A	Meter Bracket	.05
1	G1-24720	A. F. Transformer	2.00
1	W-22417	(10-10) Ohms	.15
1	W-22180	1650 Ohms	.25
1	W-22873	220 Ohms	.25
1	W-24537	60 Ohms	.25
1	W-24535	9550 Ohms	.25
1	W-24536	2000 Ohms	.25
1	W-5794	6500 Ohms	.25
1	W-23868	2000 Ohms	.25
1	W-25013	2000 Ohms	.25
1	W-21435	300,000 Ohms	.25
2	W-23701	6 Mfd.	1.00
2	W-23705	12 Mfd.	1.25
1	W-4924	00025 Mfd.	.25
1	W-23635	006 Mfd.	.25
1	W-23142	.02 Mfd.	.25
4	W-23688	.1 Mfd.	.25
1	C-24452A	Tube & Cond. Shield	.25
1	LB-21932C	Tennaboard Assy.	.15
1	W-22300	Knob	.15
1	W-24536	Knob	.15
1	LC-24484	304M Speaker (Magnavox)	8.50
1	LC-22982B	304J Speaker (Jensen)	10.00
1	L-24461	10 Cabinet Assembly	8.00
1	L-24462	I. T. Cabinet Assembly	36.50

DEWALD RADIO

MODEL AC 171-2
 MODEL DC 173-4
 MODEL DC 273
 Schematic

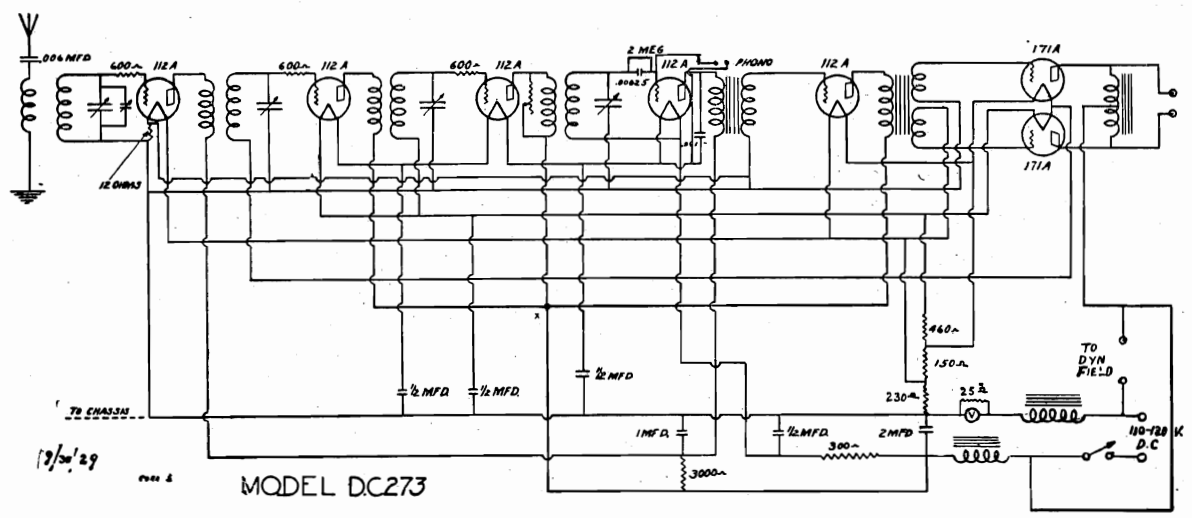
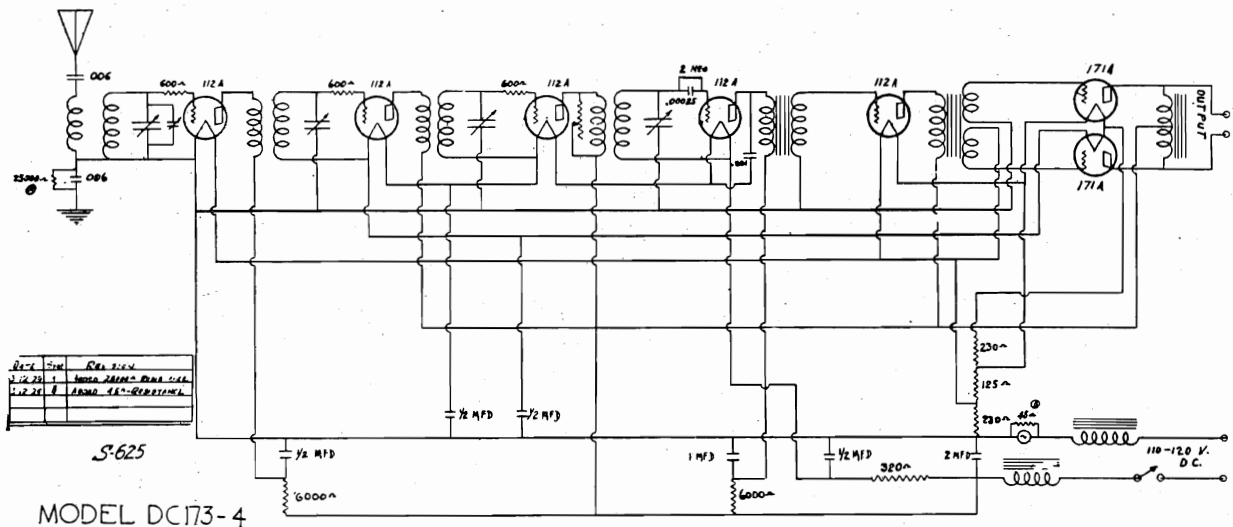
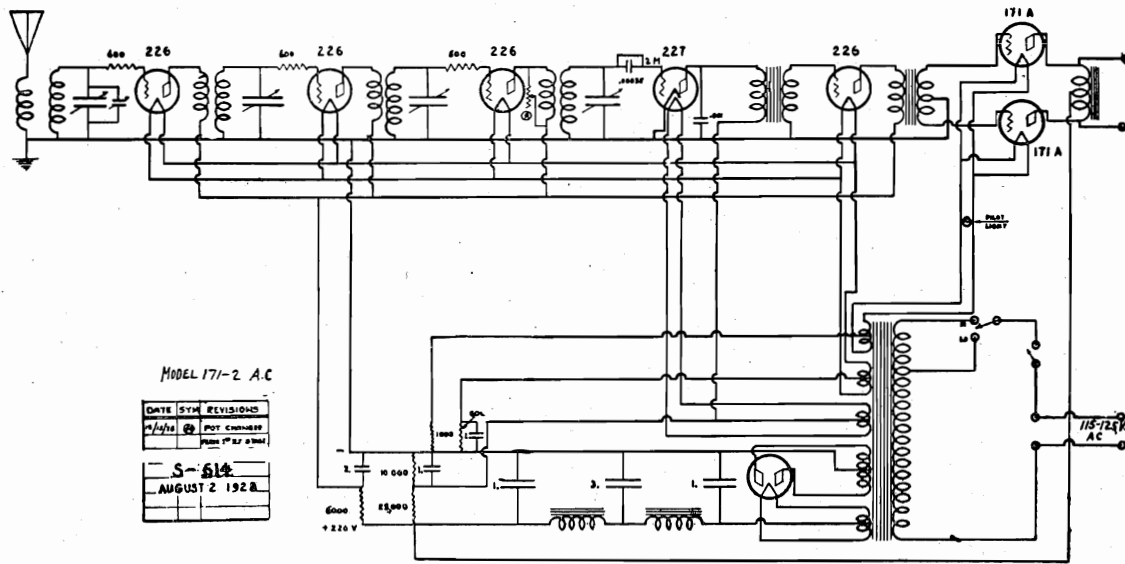

DEWALD RADIO

MODEL AC 447-M

MODEL DC 532-3

Schematic

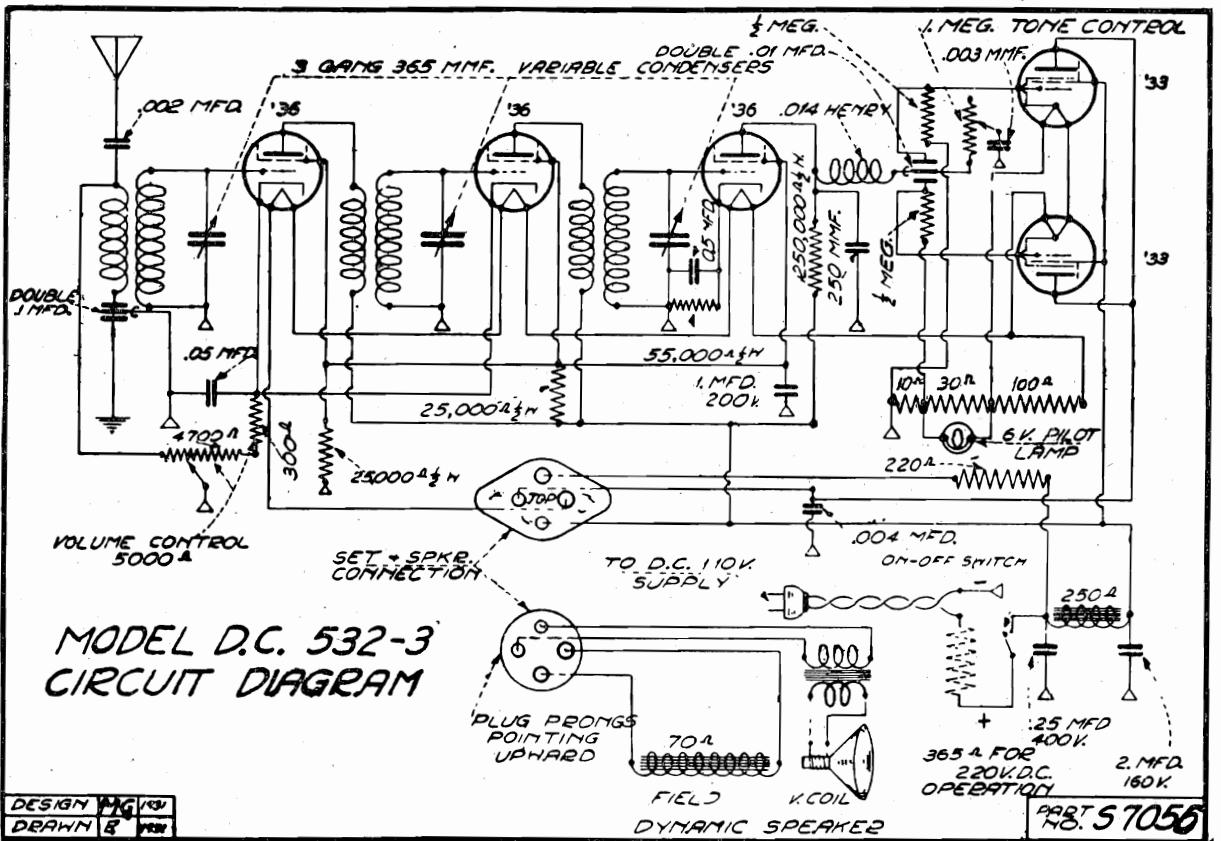
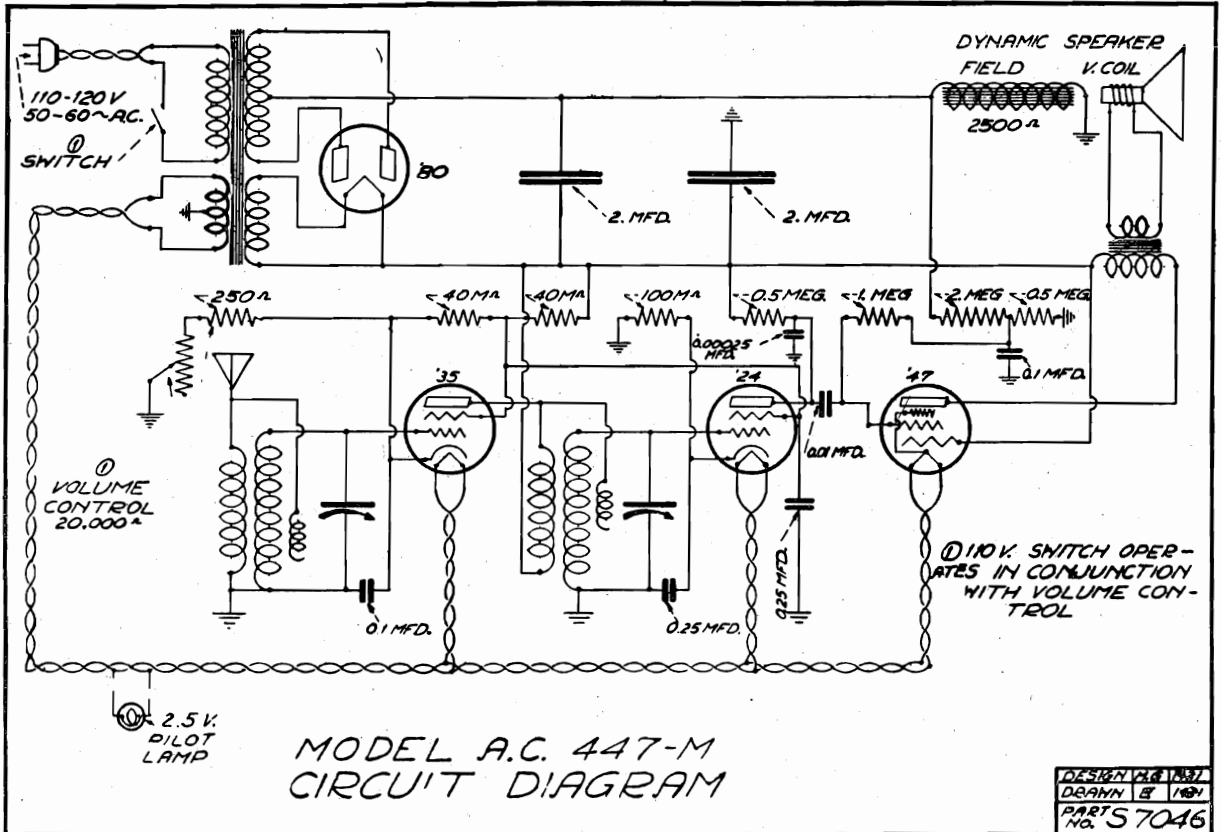

MODEL AC 724

DEWALD RADIO

Socket Data

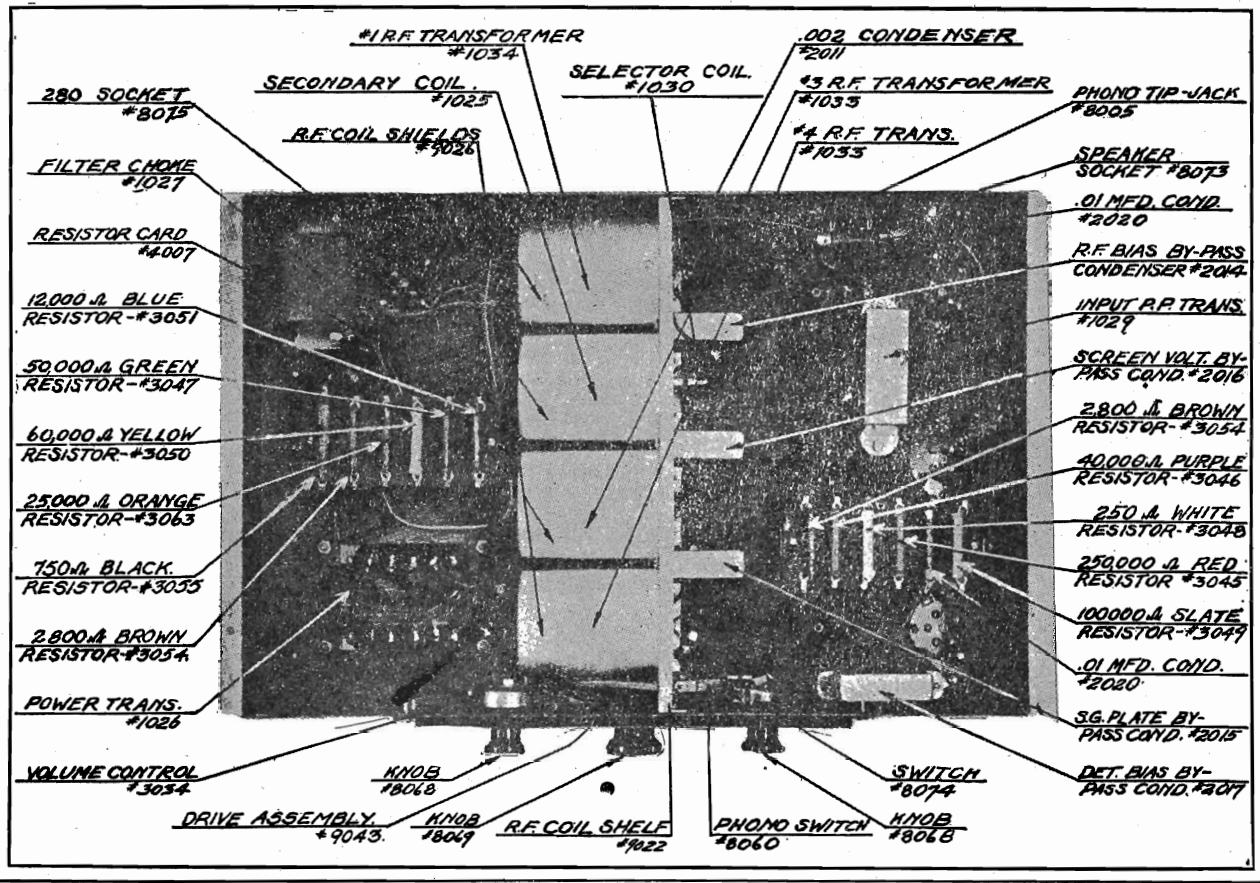
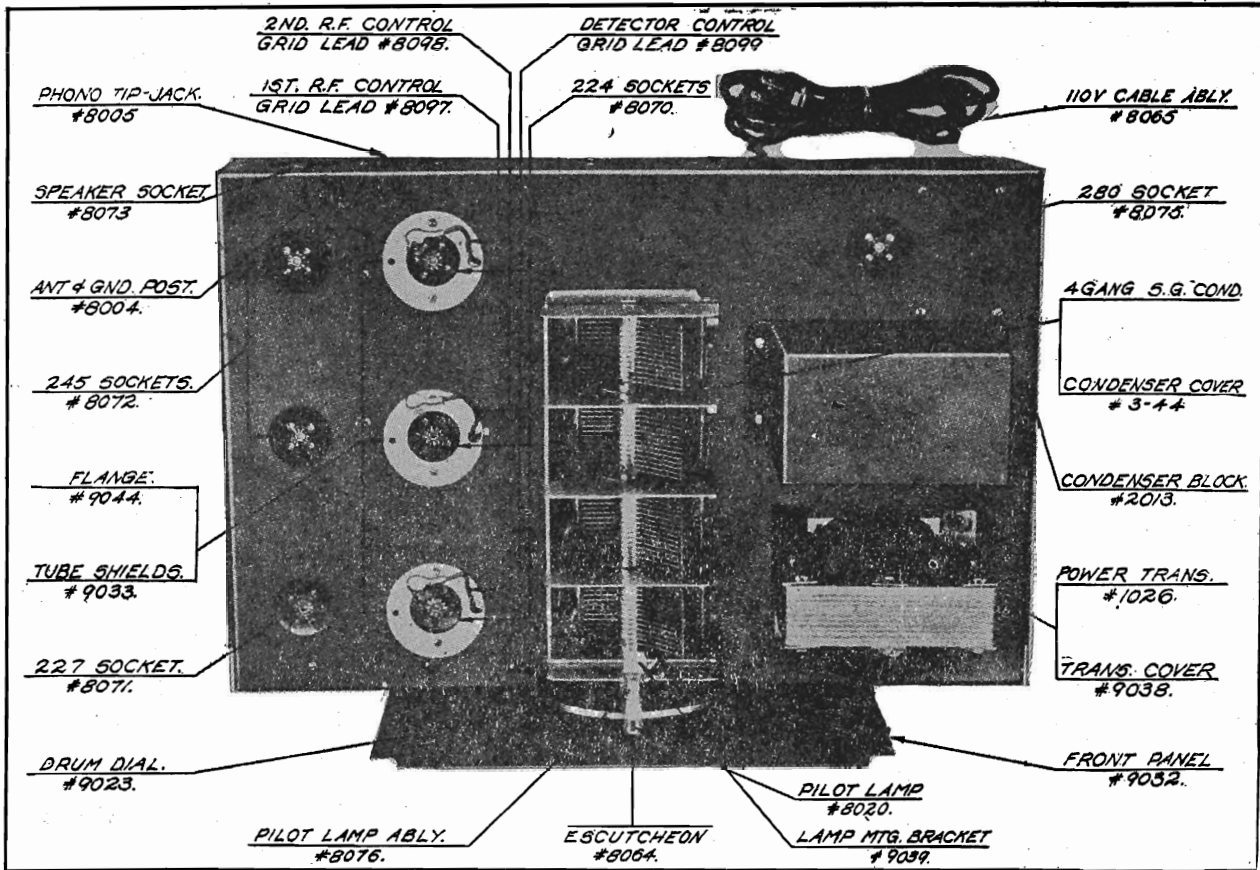

EARL RADIO CORP.

MODEL 21, 22 AC
Data

PARTS IDENTIFICATION BY COLOR

Resistances:

Large carbon resistances:

- Black — 500 Ohms
- Yellow—4700 Ohms
- Green —1000 Ohms

Small carbon resistances:

- Yellow—25000 Ohms
- Gray — 2000 Ohms
- Brown—15000 Ohms
- Green —2 Megohms

Bypass condenser:

This condenser is equipped with one terminal lug and one lead, and may be identified by the color of the latter.

- Green—0.5 mfd.—200 V.

Filter condenser block:

The individual sections of this condenser block can be identified by the color lead as follows:

- Orange—1 mfd.—200 V.
- Gray—2 mfd.—200 V.
- Blue—4 mfd.—400 V.
- Yellow—1 mfd.—400 V. for 60 cycles
- 2 mfd.—400 V. for 25 cycles

Condensers:

Moulded bakelite fixed condensers:

These condensers can be identified by a colored spot as follows:

- Red spot —.0001 mfd.
- Yellow spot—.00021 mfd.
- Green spot —.00025 mfd.
- Blue spot —.002 mfd.

- Red—1 mfd.—400 V.
- Green—0.5 mfd.—200 V.
- Brown—0.1 mfd.—400 V.

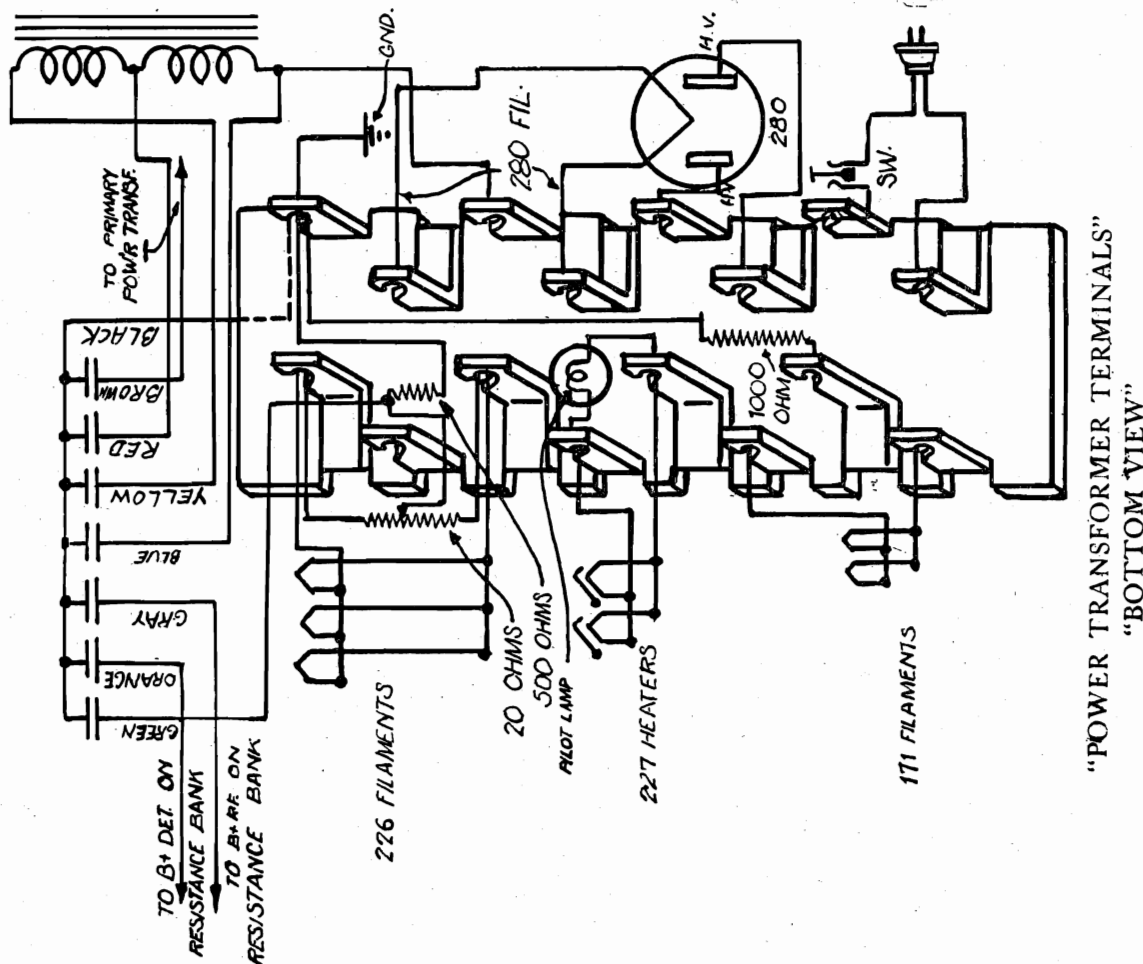

PARTS IDENTIFICATION BY COLOR

Resistances:

Large enameled wire-wound resistances:

- Green—4000-750 Ohms
- Red —5000 Ohms

Small carbon resistances:

- Gray — 2000 Ohms
- Brown—15000 Ohms
- Yellow—25000 Ohms
- Green —2 Megohms
- Red — 375 Ohms
- Black — 500 Ohms

Condensers:

Moulded bakelite fixed condensers:

These condensers can be identified by a colored spot as follows:

- Blue spot —.002 mfd.
- Green spot —.00025 mfd.
- Red spot —.0001 mfd.
- Yellow spot—.00021 mfd.

Bypass condensers:

These condensers are equipped with one terminal lug and one lead, and may be identified by the color of the latter.

- Red —0.1 mfd.
- Green—0.5 mfd.—200 V.

Filter condenser block:

The individual sections of this condenser block can be identified by the color lead as follows:

- Black—Common lead to all sections except 0.1 mfd.
- Brown (2 leads)—0.1 mfd.—400 V.
- Blue—4 mfd.—400 V.
- Green—1 mfd.—600 V. for 60 cycles
2 mfd.—600 V. for 25 cycles
- Red —1 mfd.—600 V.
- Yellow—1 mfd.—400 V.
- Orange—1 mfd.—400 V.

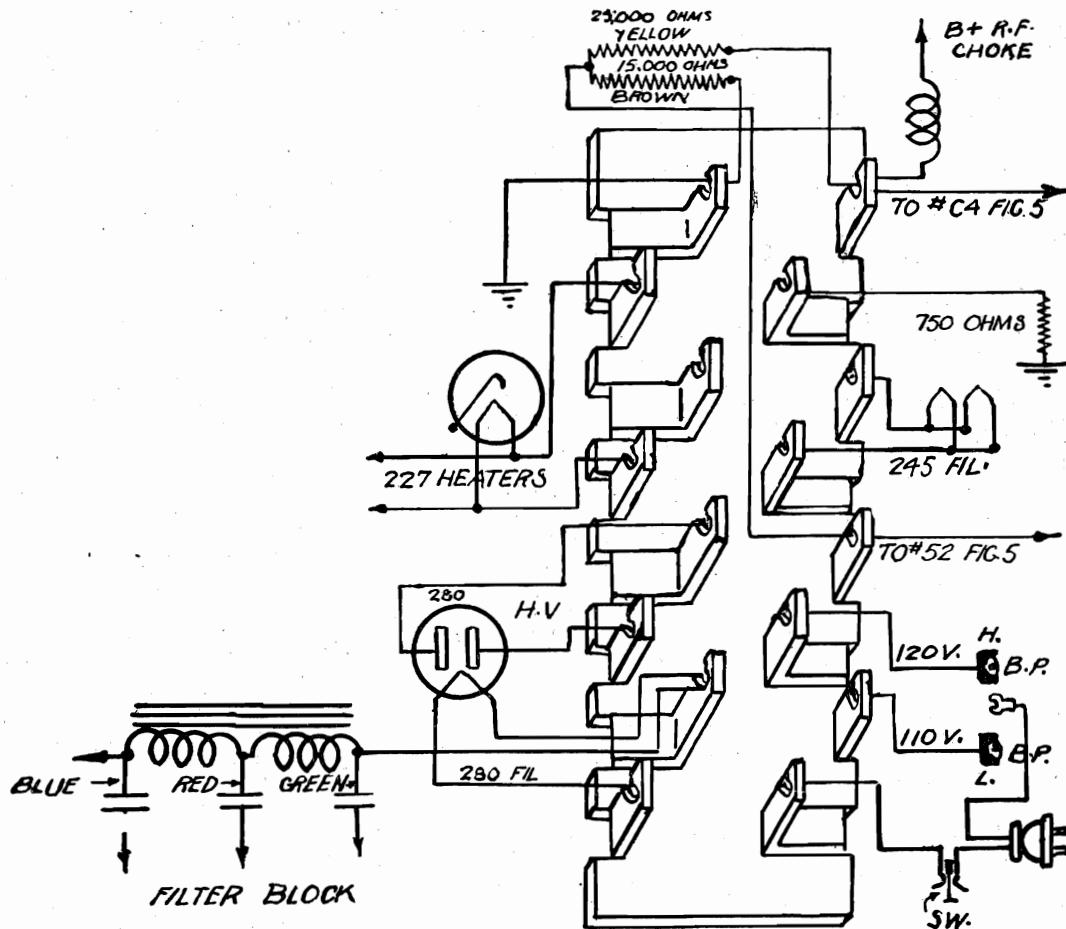

"BOTTOM VIEW"

"POWER TRANSFORMER TERMINAL STRIP"

MODEL 41, 42 AC
Data

EARL RADIO CORP.

PARTS IDENTIFICATION BY COLOR

Resistances:

Large enameled wire-wound resistances:
Green—4000-750 Ohms
Red —5000 Ohms

Small carbon resistances:
Gray — 2000 Ohms
Brown—15000 Ohms
Yellow—25000 Ohms
Green —2 Megohms
Red — 375 Ohms
Black — 500 Ohms

Condensers:

Moulded bakelite fixed condensers:
These condensers can be identified by a colored spot as follows:
Blue spot —.002 mfd.
Green spot —.00025 mfd.
Red spot —.0001 mfd.
Yellow spot—.00021 mfd.

Bypass condensers:

These condensers are equipped with one terminal lug and one lead, and may be identified by the color of the latter.

Red —0.1 mfd.
Green—0.5 mfd.—200 V.

Filter condenser block:

The individual sections of this condenser block can be identified by the color lead as follows:

Black—Common lead to all sections except 0.1 mfd. section.
Brown (2 leads)—0.1 mfd.—400 V.
Blue—4 mfd.—400 V.
Green—1 mfd.—600 V. for 60 cycles
2 mfd.—600 V. for 25 cycles
Red —1 mfd.—600 V.
Yellow—1 mfd.—400 V.
Orange—1 mfd.—400 V.

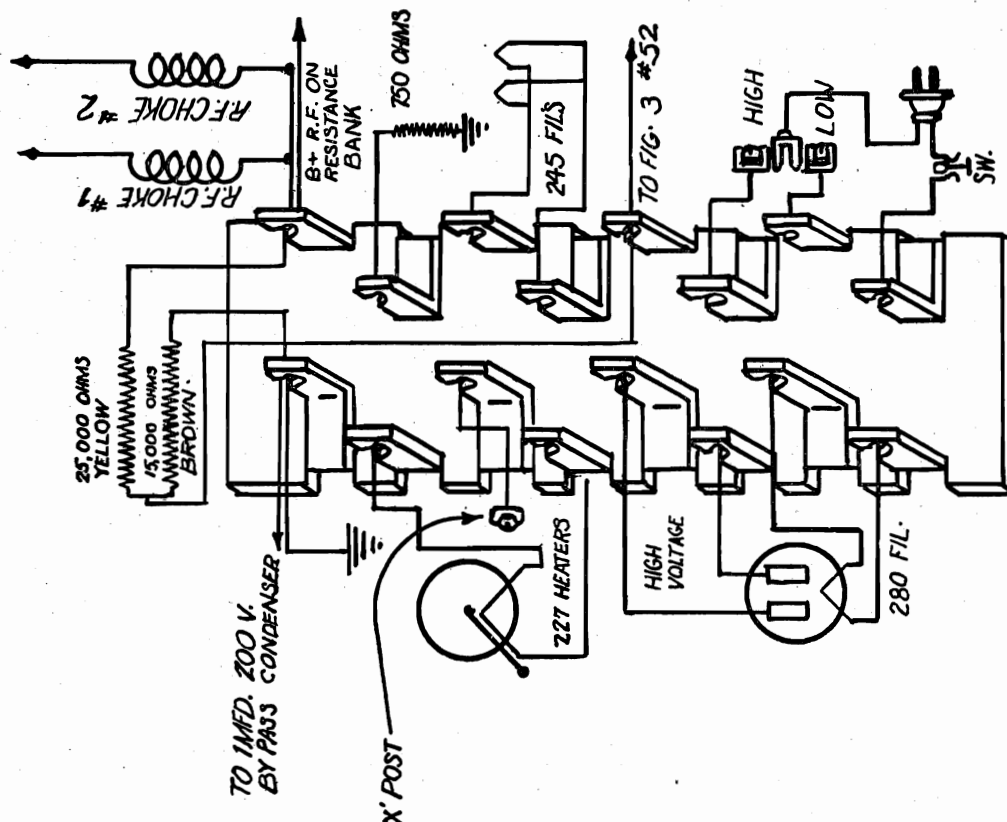

ECHOPHONE RADIO MFG. CO.

MODEL F
Voltage
MODEL 40
Voltage

Model F VOLTAGE TESTS

Voltages given are tested on 250 volt scale of 1000 ohms per volt meter.

All voltage tests were made with volume control on full and tone control in off position, no signal in receiver, line voltage 115 volts. Speaker must be connected to receiver.

R. F. Plate		Detector Cathode	
Low	210 volts		3 to 6 volts
Normal	220 "	245 Plate	
High	230 "	Low	210 volts
R. F. Screen		Normal	220 "
Low	75 volts	High	230 "
Normal	80 "	245 Bias	
High	90 "		20 to 40 volts
R. F. Cathode		280 Filament	
	1.5 to 2.5 volts		4.5 to 5.2 volts
Detector Plate		Filaments for all 2.5 Volt Tubes	
Low	55 volts		2.2 to 2.5 volts
Normal	65 "	Speaker Field Voltage Drop	
High	75 "		90 to 110 volts
Detector Screen			
Low	25 volts		
Normal	30 "		
High	35 "		

Model 40 Echoette VOLTAGE TESTS

All voltages given were tested on 250 volt scale of 1000 ohms per volt meter.

All voltage tests were made with volume on full and no signal in receiver, line voltage 115 volts with A. C. line connected to tap of transformer as shipped from factory.

247 Plate to ground
230 to 250 volts

R. F. Plate to ground
240 to 260 volts

247 Screen to ground
240 to 260 volts

R. F. Screen to ground
70 to 85 volts

247 Grid to ground
6 to 8 volts

R. F. Bias—Cathode to ground
2.5 to 3.5 volts

Det. Plate to ground
25 to 35 volts

Filament All 2.5 volt tubes
2.4 to 2.6

Det. Screen to ground
30 to 40 volts

Filament 280 tube
4.8 to 5 volts

Det. Bias cathode to ground
7 to 9 volts

R. F. Cathode volume control in off position
40 to 50 volts

Voltage across speaker field
90 to 110 volts.

MODEL F
Schematic

ECHOPHONE RADIO MFG. CO.

Model F (1931)

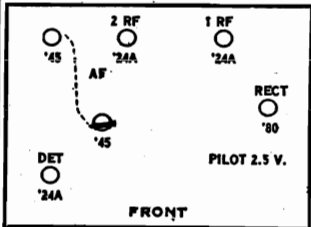

The bias for the 45 tubes is obtained through a one megohm resistor connected to the midpoint of the two resistors across the dynamic speaker field which is in the negative lead.

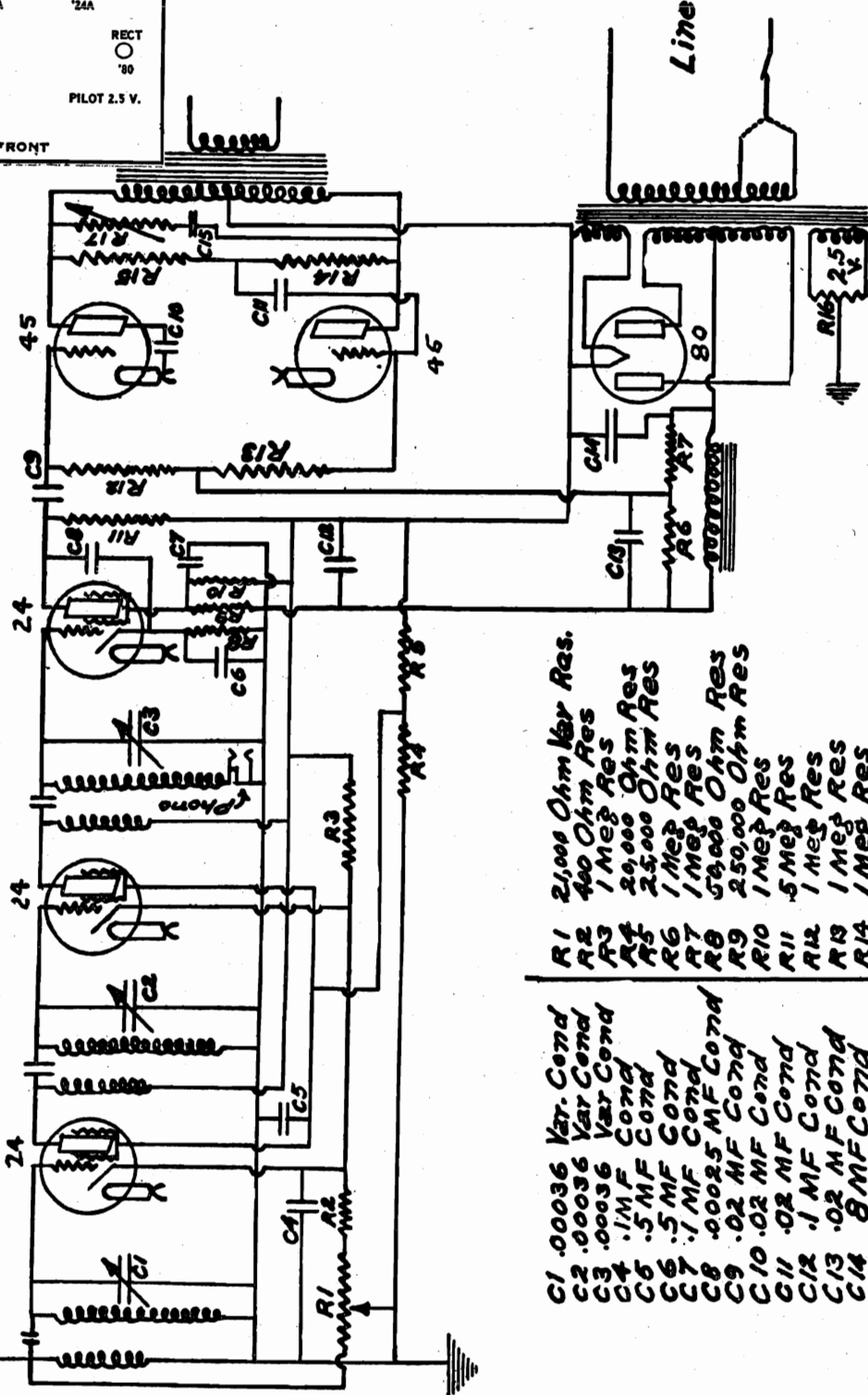

- | | | |
|------|---------|--------------|
| C1 | .00036 | Var. Cond |
| C2 | .00036 | Var Cond |
| C3 | .00036 | Var Cond |
| C4 | .1MF | Cond |
| C5 | .5MF | Cond |
| C6 | .5MF | Cond |
| C7 | .1MF | Cond |
| C8 | .0025 | MF Cond |
| C9 | .02 | MF Cond |
| C10 | .02 | MF Cond |
| C11 | .02 | MF Cond |
| C12 | .1MF | Cond |
| C13 | .02 | MF Cond |
| C14 | .8MF | Cond |
| C15 | 1 | MF Cond. |
| R1 | 21,000 | Ohm Var Res. |
| R2 | 400 | Ohm Res |
| R3 | 1Meg | Res |
| R4 | 20,000 | Ohm Res |
| R5 | 25,000 | Ohm Res |
| R6 | 1Meg | Res |
| R7 | 1Meg | Res |
| R8 | 50,000 | Ohm Res |
| R9 | 250,000 | Ohm Res |
| R10 | 1Meg | Res |
| R11 | .5Meg | Res |
| R12 | 1Meg | Res |
| R13 | 1Meg | Res |
| R14 | 1Meg | Res |
| R15 | 250,000 | Ohm Res |
| R-16 | 20 | Ohm C.T. Res |
| R17 | 15,000 | Ohm Var Res |

The filter circuit consists of an 8 M. F. electrolytic condenser and the 1500 ohm field of the dynamic speaker. The hum balance is used in connection with the bias resistors of the 45 tubes, a condenser of proper capacity being connected from the midpoint of these resistors to ground.

ECHOPHONE - Model F

MODEL 40
Schematic

ECHOPHONE RADIO MFG. CO.

ECHOPHONE
Model 40 Echoette

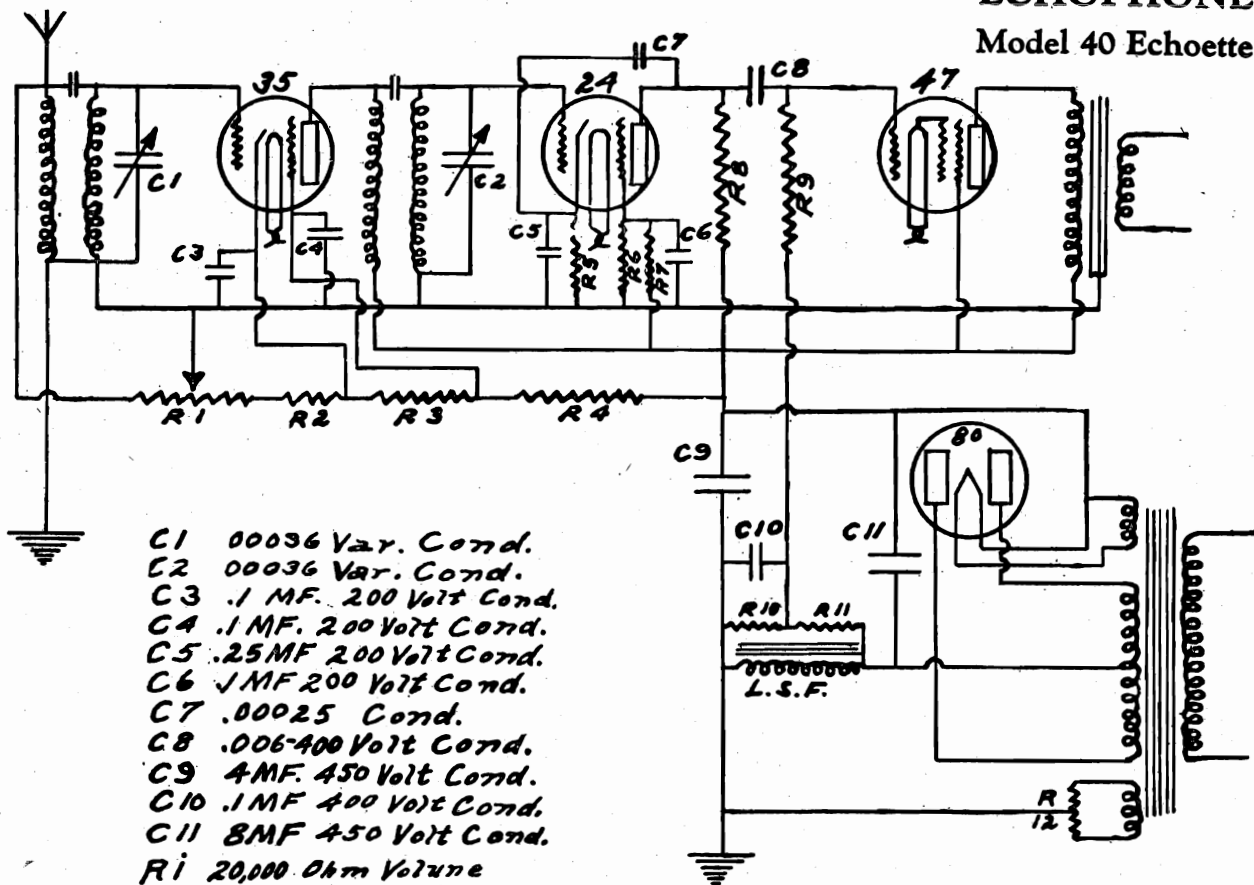

- C1 00036 Var. Cond.
- C2 00036 Var. Cond.
- C3 .1 MF. 200 Volt Cond.
- C4 .1 MF. 200 Volt Cond.
- C5 .25 MF 200 Volt Cond.
- C6 .1 MF 200 Volt Cond.
- C7 .00025 Cond.
- C8 .006-400 Volt Cond.
- C9 4 MF. 450 Volt Cond.
- C10 .1 MF 400 Volt Cond.
- C11 8 MF 450 Volt Cond.
- R1 20,000 Ohm Volume Control With R2 300 Ohm Fixed Bias
- R3 35000 Ohm .5 Watt
- R4 50000 Ohm 1 Watt
- R5 50000 Ohm 1 Watt
- R6 .5 Meg 1 Watt
- R7 1 Meg .5 Watt
- R8 1.5 Meg .5 Watt
- R9 .5 Meg 1 Watt
- R10 .2 Meg .5 Watt

- R11 1 Meg .5 Watt
- R12 20 Ohm C.T. Resistor

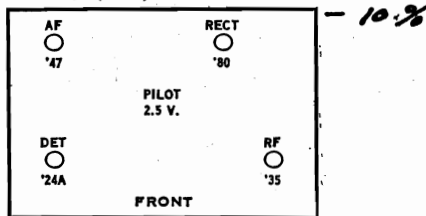

In the later models the speaker field is in the negative lead and part of the drop across it is used to bias the grid of the power tube. A bucking coil is used in the speaker to keep the field ripple out of the voice coil.

The R. F. stage is impedance coupled and there is a small coupling condenser fastened on the lower end of the R. F. coil. If the set is weak or oscillates at the high frequency end of the band a slight adjustment of this condenser will remedy the trouble. After adjusting this condenser the gang condenser should be checked for alignment with the rotor plates nearly open.

The filter circuit consists of an 8 M. F. and 4 M. F. electrolytic condenser and the 2000 ohm speaker field. The speaker field is in the positive lead and the power tube is self biased by a resistor from the filament circuit to ground. This resistor is by-passed by an 8 M. F. condenser.

ECHOPHONE RADIO MFG. CO.

MODEL 60
Schematic

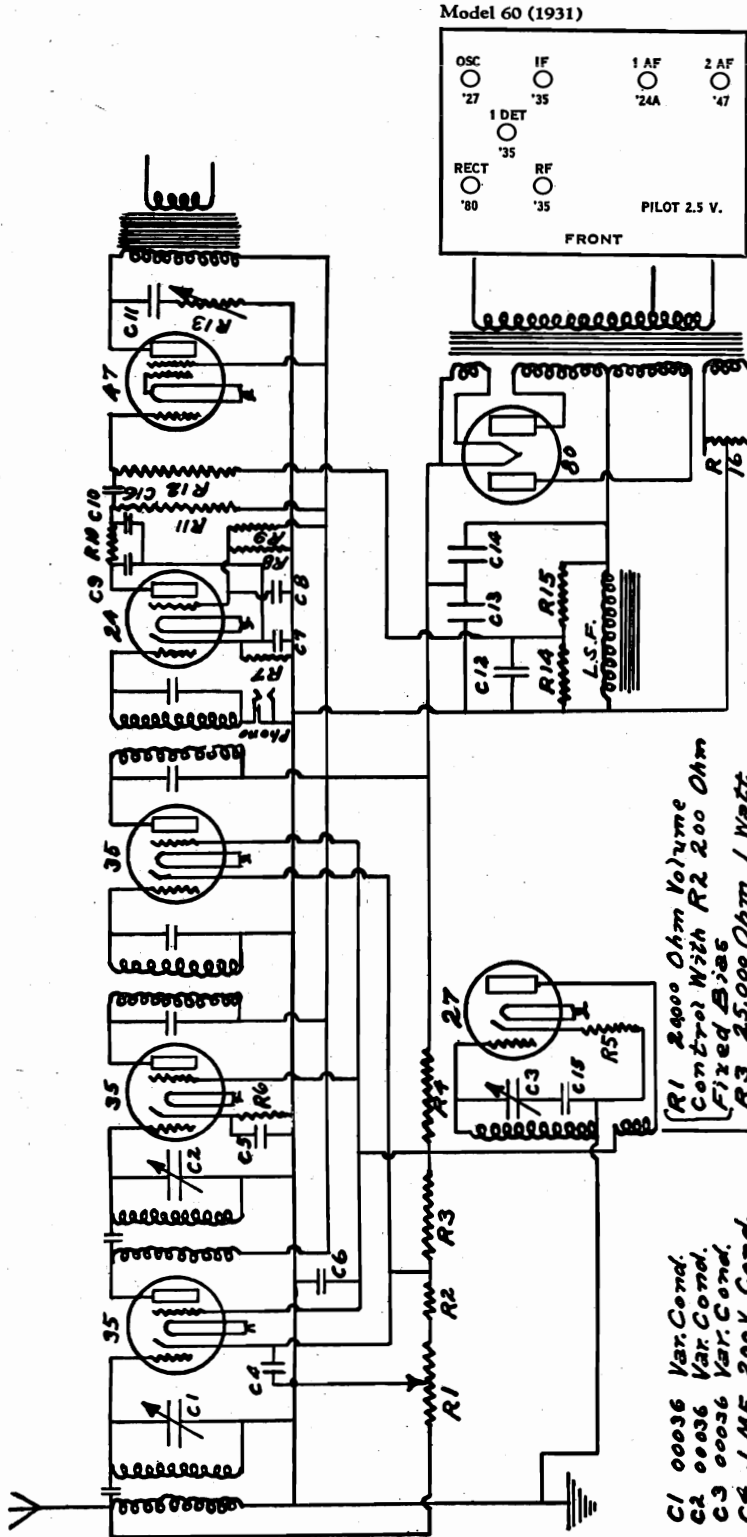

PEAK FREQUENCY 175 KC

ECHOPHONE
Model 60 Superheterodyne

- C1 00036 Var. Cond.
- C2 00036 Var. Cond.
- C3 00036 Var. Cond.
- C4 .1 MF 200 V. Cond.
- C5 .1 MF 200 V. Cond.
- C6 .1 MF 200 V. Cond.
- C7 .5 MF 200 V. Cond.
- C8 .1 MF 200 V. Cond.
- C9 .00025 Cond.
- C10 .001 Cond.
- C11 .05 MF 400 V. Cond.
- C12 .1 MF 400 V. Cond.
- C13 8 MF 450 V. Cond.
- C14 8 MF 450 V. Cond.
- C15 .001 Cond. + .3%
- C16 .006 MF 400 V. Cond.
- R1 2000 Ohm Volume Control With R2 200 Ohm Fixed Bias
- R2 25,000 Ohm 1 Watt
- R3 20,000 Ohm 2 Watt
- R4 1000 Ohm .5 Watt
- R5 1500 Ohm .5 Watt
- R6 50,000 Ohm .5 Watt
- R7 .5 Meg .5 Watt
- R8 1.1 Meg .5 Watt
- R9 150,000 Ohm .5 Watt
- R10 .5 Meg 1 Watt
- R11 .5 Meg 1 Watt
- R12 20,000 Ohm Tone Control
- R13 20,000 Ohm .5 Watt
- R14 1.1 Meg .5 Watt
- R15 20,000 Ohm Center Tapped Res.
- R16 20 Ohm Center Tapped Res.

All Condensers + - 10%
Unless Otherwise Specified

All Resistors + - 10%
Unless Otherwise Specified

Resistor Panel-2-1 Meg. 1/2 watt, 1-200,000 ohm 1/2 watt-2 1/2 Meg. 1 watt, 1-20,000 ohm 2 watt, 1-25,000 ohm 1 watt, 1-1/2 Meg. 1/2 watt, 1-50,000 ohm 1/2 watt, 1-1500 ohm 1/2 watt

The filter circuit consists of two 8 MF electrolytic condensers and the 1500 ohm speaker field. The hum balance circuit is used in connection with the power tube bias resistors. The speaker field is in the negative lead and part of the voltage drop across it is used for biasing the power tube. A bucking coil is used in the speaker to keep the field ripple out of the voice coil.

MODEL 60
Voltage
MODEL 80
Voltage

ECHOPHONE RADIO MFG. CO.

VOLTAGE TESTS

All voltages given were tested on a 250 volt scale of 1000 ohms per volt meter.

All voltage tests were made with volume on full, and tone control in off position, no signal in receiver, line voltage 115 volts with A. C. line connected to tap of transformer as shipped from factory.

Model 60 Superheterodyne

First Det. Plate to ground 230 to 250 volts	247 Plate to ground 230 to 245 volts
First Det. Screen to ground 70 to 80 volts	247 Screen to ground 230 to 250 volts
First Det. Bias—Cathode to ground 4 to 6 volts	247 Bias grid to ground 6 to 8 volts
Oscillator Plate to ground 70 to 80 volts	Second Det. Plate to ground 35 to 45 volts
Oscillator Bias—Cathode to ground 4 to 6 volts	Second Det. screen to ground 30 to 40 volts
R.F. & I.F. Bias with volume control in off position 40 to 50 volts	Second Det. Bias—Cathode to ground 7 to 9 volts
Filament for all 2.5 volt tubes 2.4 to 2.6 volts	R.F. & I.F. Plate to ground 230 to 250 volts
Filament of 280 tube 4.8 to 5 volts	R.F. & I.F. Screen to ground 70 to 80 volts
Voltage across speaker field 80 to 90 volts	R.F. & I.F. Bias—Cathode to ground 2.5 to 3.5 volts

Model 80 Superheterodyne

First Det: Plate to ground 230 to 245 volts	247 Plate to ground 225 to 235 volts
First Det. Screen to ground 70 to 80 volts	247 Screen to ground 230 to 245 volts
First Det. Bias—Cathode to ground 4 to 6 volts	247 Bias—Center Tapped resistor to ground 16 to 18 volts
Oscillator plate to ground 70 to 80 volts	Second Det. Plate to ground 30 to 40 volts
Oscillator Bias Cathode to ground 4 to 6 volts	Second Det. Screen to ground 25 to 35 volts
R.F. & I.F. Bias with volume control in off position 40 to 50 volts	Second Det. Bias—Cathode to ground 7 to 9 volts
Filament for all 2.5 volt tubes 2.4 to 2.6 volts	R.F. & I.F. Plate to ground 230 to 245 volts
Filament of 280 tube 4.8 to 5 volts	R.F. & I.F. Screen to ground 70 to 80 volts
Voltage across speaker field 90 to 110 volts	R.F. & I.F. Bias—Cathode to ground 2.5 to 3.5 volts

ECHOPHONE RADIO MFG. CO.

MODEL 90
Schematic

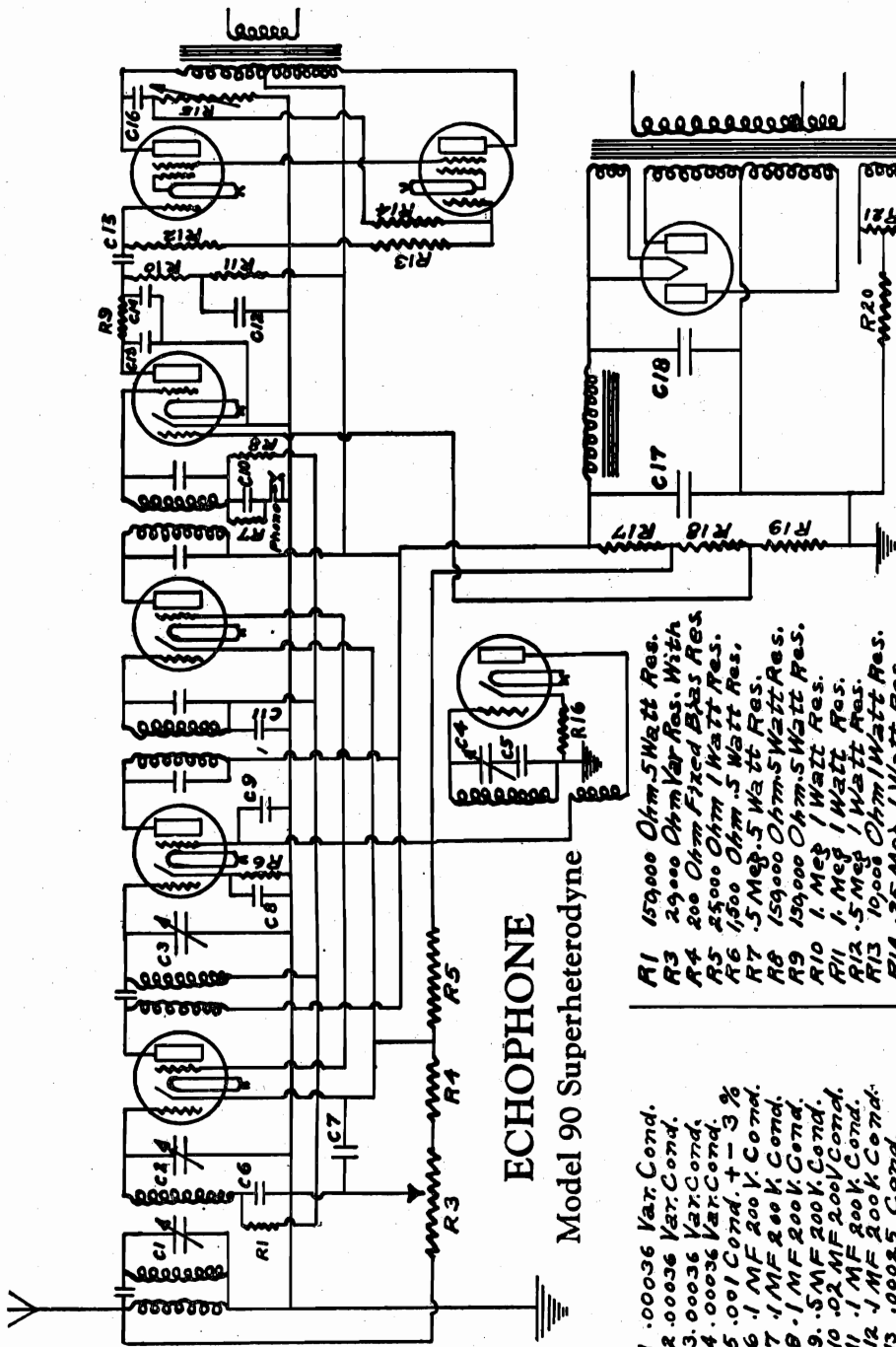

ECHOPHONE
Model 90 Superheterodyne

- C1 .00036 Var. Cond.
- C2 .00036 Var. Cond.
- C3 .00036 Var. Cond.
- C4 .00036 Var. Cond.
- C5 .001 Cond. + - 3%
- C6 .1 MF 200 V. Cond.
- C7 .1 MF 200 V. Cond.
- C8 .1 MF 200 V. Cond.
- C9 .5 MF 200 V. Cond.
- C10 .02 MF 200 V. Cond.
- C11 .1 MF 200 V. Cond.
- C12 .1 MF 200 V. Cond.
- C13 .00025 Cond.
- C14 .0001 Cond.
- C15 .02 MF 400 V. Cond.
- C16 .05 MF 400 V. Cond.
- C17 .8 MF 450 V. Cond.
- C18 12 MF 450 V. Cond.

All Condensers + - 10%
Unless Otherwise Specified

- R1 15,000 Ohm 5 Watt Res.
- R3 29,000 Ohm Var Res. With
- R4 200 Ohm Fixed Bias Res.
- R5 5,000 Ohm 1 Watt Res.
- R6 1,500 Ohm .5 Watt Res.
- R7 5 Meg. 5 Watt Res.
- R8 15,000 Ohm 5 Watt Res.
- R9 15,000 Ohm 5 Watt Res.
- R10 1. Meg 1 Watt Res.
- R11 5 Meg 1 Watt Res.
- R12 5 Meg 1 Watt Res.
- R13 10,000 Ohm 1 Watt Res.
- R14 .25 Meg 1 Watt Res.
- R15 29,000 Ohm Tone Control
- R16 1,000 Ohm .5 Watt Res.
- R17 15,000 Ohm 1 Watt Res.
- R18 50,000 Ohm 1 Watt Res.
- R19 2,000 Ohm 1 Watt Res.
- R20 250 Ohm 2 Watt Res.
- R21 20 Ohm Center Tapped Res.

All Resistors + - 10%
Unless Otherwise Specified

- Resistor Panel 5 Meg 1 Watt, 1; 10,000 Ohm 1 Watt, 1; 25 Meg 1 Watt, 1; 250 Ohm 2 Watt, 1; 1 Meg 1 Watt, 2; 15,000 Ohm 1 Watt, 1; 2,000 Ohm 1 Watt, 1

PEAK FREQUENCY=175 KC

Model 90 (1931)

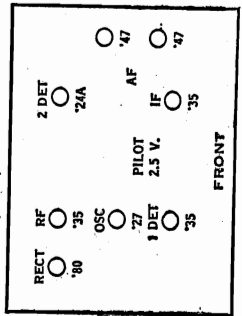

The Echophone, Model 90, is an 8-tube Superheterodyne, employing variable MU and Pentode Tubes.

The circuit consists of a pre-selector; one stage of high gain R.F. amplification using a type 235 tube; a first detector using a type 235 tube; one stage of intermediate frequency amplification using a type 235 tube; a second detector using a type 235 tube; a single audio stage using two type 247 Pentode tubes in a resistance coupled push-pull circuit; an oscillator using a type 227 tube, and a power supply system using a type 280 tube.

The antenna and pre-selector coils are mounted on top of the chassis, and are tuned by the first and second sections of the gang condenser.

MODEL 90
Voltage
Notes

ECHOPHONE RADIO MFG. CO.

Model 90—Superheterodyne

The first detector is of the grid biased type. The second detector is a type 235 tube used as a space charge detector. In this system, the screen grid is used as a control grid and a small positive voltage is applied to the top grid which is normally used as the control grid. A grid leak and condenser are used in the control grid circuit, and the negative voltage developed across the grid leak when strong signals are received is fed back to the R.F., first detector and I.F. grids which gives the semi-automatic volume control, and prevents overloading of the second detector. A phonograph pickup jack is incorporated in the grid return of this tube.

The R.F. Circuit is a high gain impedance coupled type with capacity coupling condenser mounted on coil. This condenser should require no adjustment after leaving factory. The fourth section of variable condenser tunes the R.F. circuit.

The oscillator circuit is of the conventional tuned grid type with plate feed back, and is inductively coupled to the grid circuit of the R.F. stage.

The intermediate frequency amplifier has a total of four tuned circuits, and is adjusted to 175 K.C.

The volume control acts as a dual control by varying the bias on the R.F. and I.F. tubes, and by varying the antenna input to the antenna coil.

The filter circuit consists of an 8 MF and a 12 MF electrolytic condenser, and the 1200 ohm speaker field. The field is in the positive lead, and the power tubes are self-biased by a resistor from the filament circuit to ground. A bucking coil is used in the speaker to keep the field ripple out of the voice coil.

VOLTAGE TESTS

All voltages given were tested on 250-volt scale of 1000 ohms per volt meter. All voltage tests made with volume on full and tone control in off position, no signal in receiver, line voltage 115 volts with A.C. line connected to tap of transformer as shipped from factory.

247 Plate to ground
230 to 240 volts

247 Screen to ground
235 to 250 volts

247 Bias-Center tap resistor to ground
13 to 18 volts

Second Det. Plate to ground
20 to 30 volts

Second Det. Screen Grid to ground
Less than 1 volt negative

Second Det. Control Grid to ground
1 to 2 volts

I.F. Plate to ground
235 to 250 volts

I.F. Screen to ground
70 to 90 volts

I.F. Cathode to ground
2 to 4 volts

R.F. Plate to ground.
235 to 250 volts

R.F. Screen to ground
70 to 90 volts

R.F. Cathode to ground
2 to 4 volts

First Det. Plate to ground
235 to 250 volts

First Det. Screen to ground
70 to 90 volts

First Det. Cathode to ground
4 to 7 volts

Oscillator Plate to ground
70 to 90 volts

Oscillator Cathode to ground
4 to 7 volts

Voltage drop across field
95 to 110 volts

Filament Voltage for all 2.5 volt tubes
2.4 to 2.6 volts

Filament Voltage for 280 tube
4.8 to 5 volts

R.F. and I.F. Cathode with volume control in
off position

40 to 50 volts

On very strong signals a small negative voltage can be measured between the R.F., I.F., and first detector grid returns and ground, due to the action of automatic volume control.

THOMAS A. EDISON, INC.

MODEL'S R4,R5,C4
Chassis Views

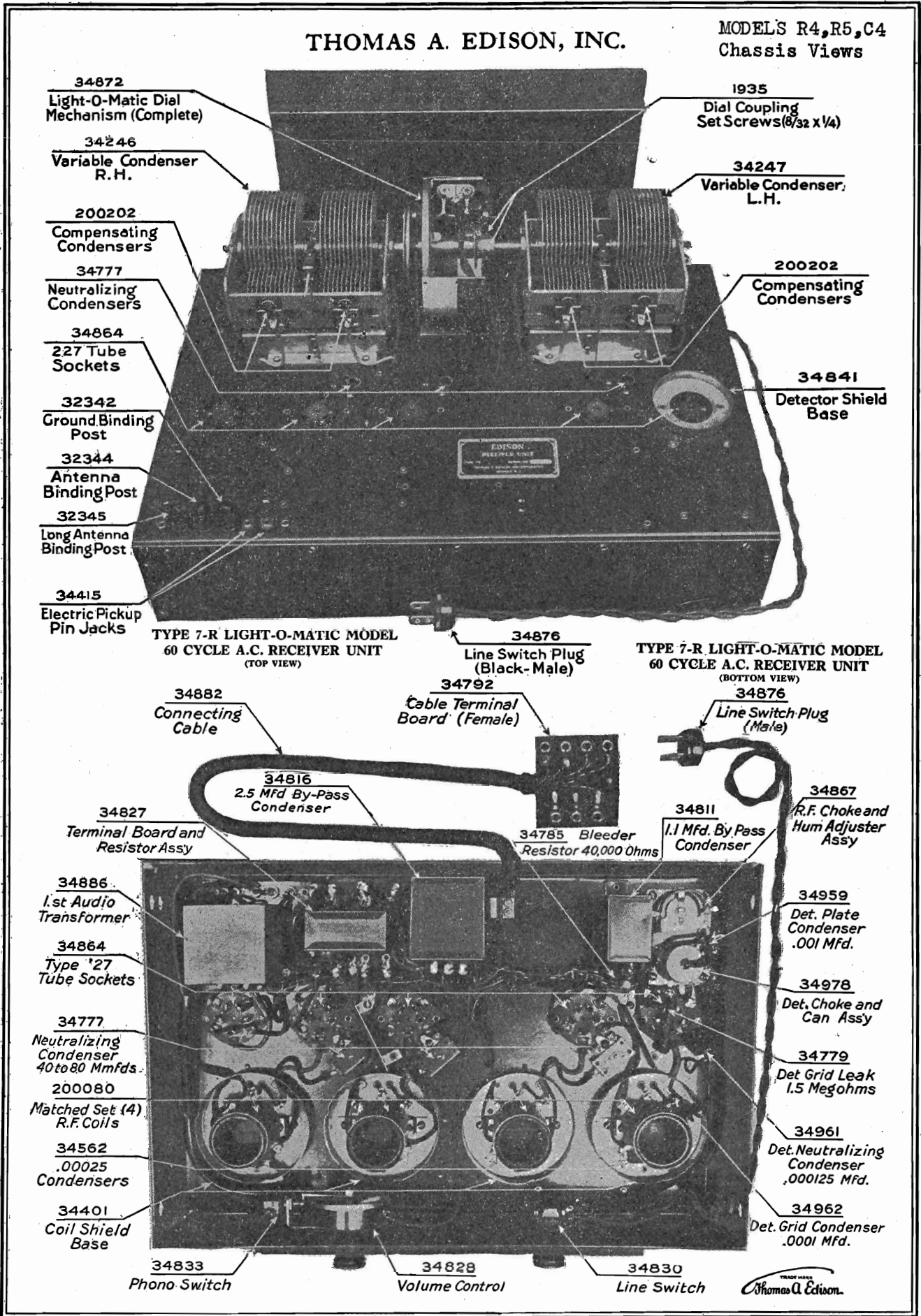

MODELS R4,R5,C4
Power Unit Chassis Views

THOMAS A. EDISON, INC.

34493 Electro-Dynamic Speaker

**TYPE 8-P LIGHT-O-MATIC MODEL
DIRECT CURRENT POWER UNIT
(TOP VIEW)**

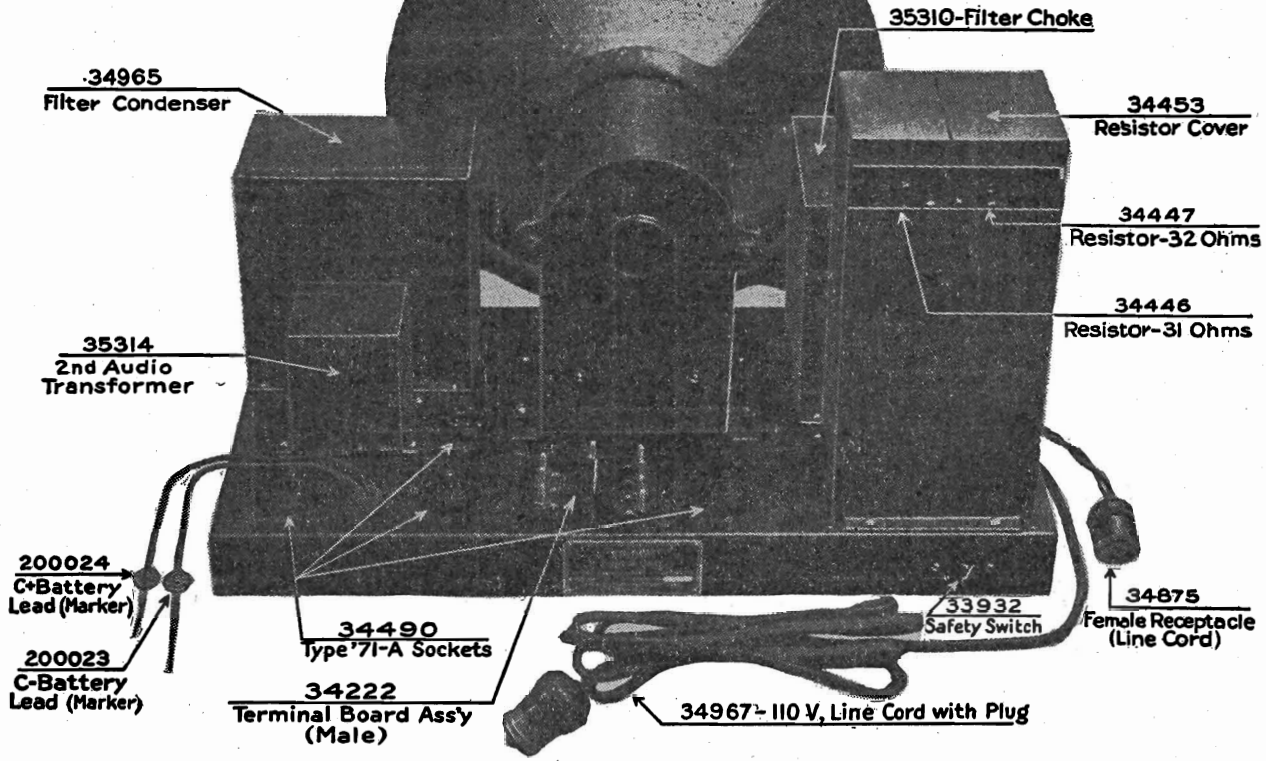

**TYPE 8-P LIGHT-O-MATIC MODEL
DIRECT CURRENT POWER UNIT
(BOTTOM VIEW)**

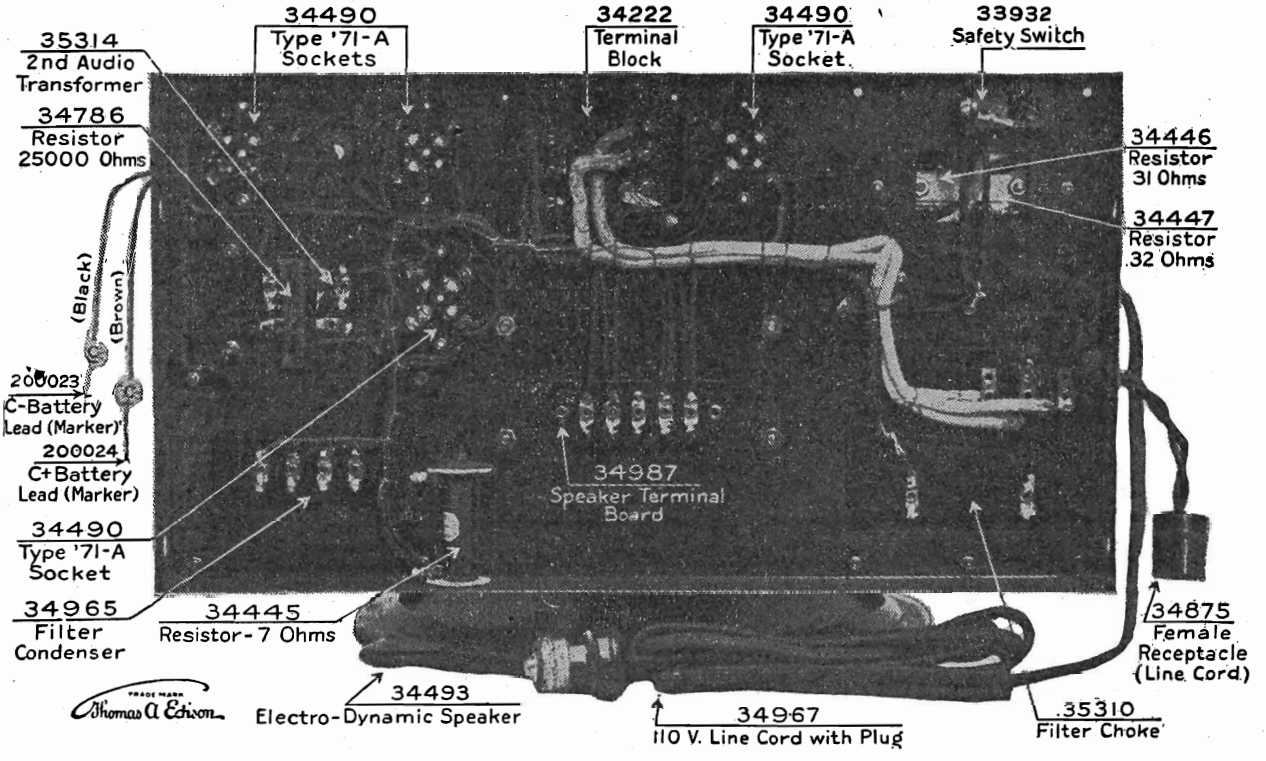

ELECTRAD, INC.

MODEL A-250
MODEL C-250

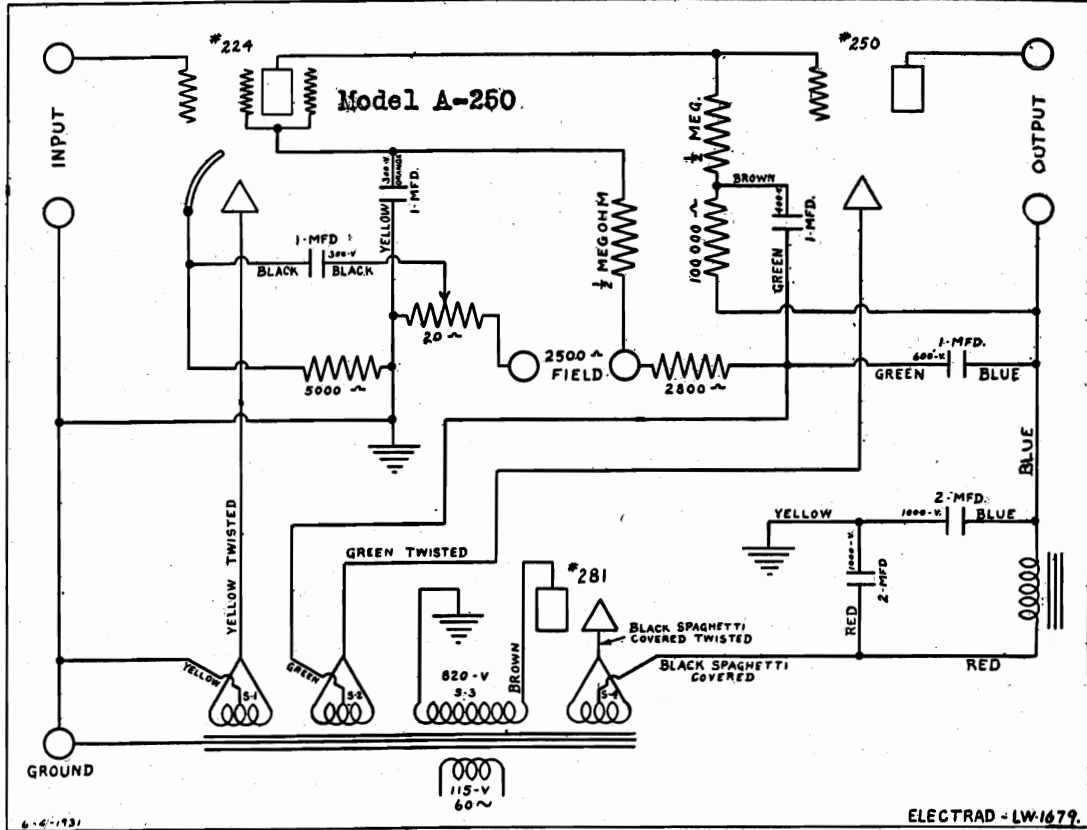

6-4-1931

ELECTRAD - LW-1679

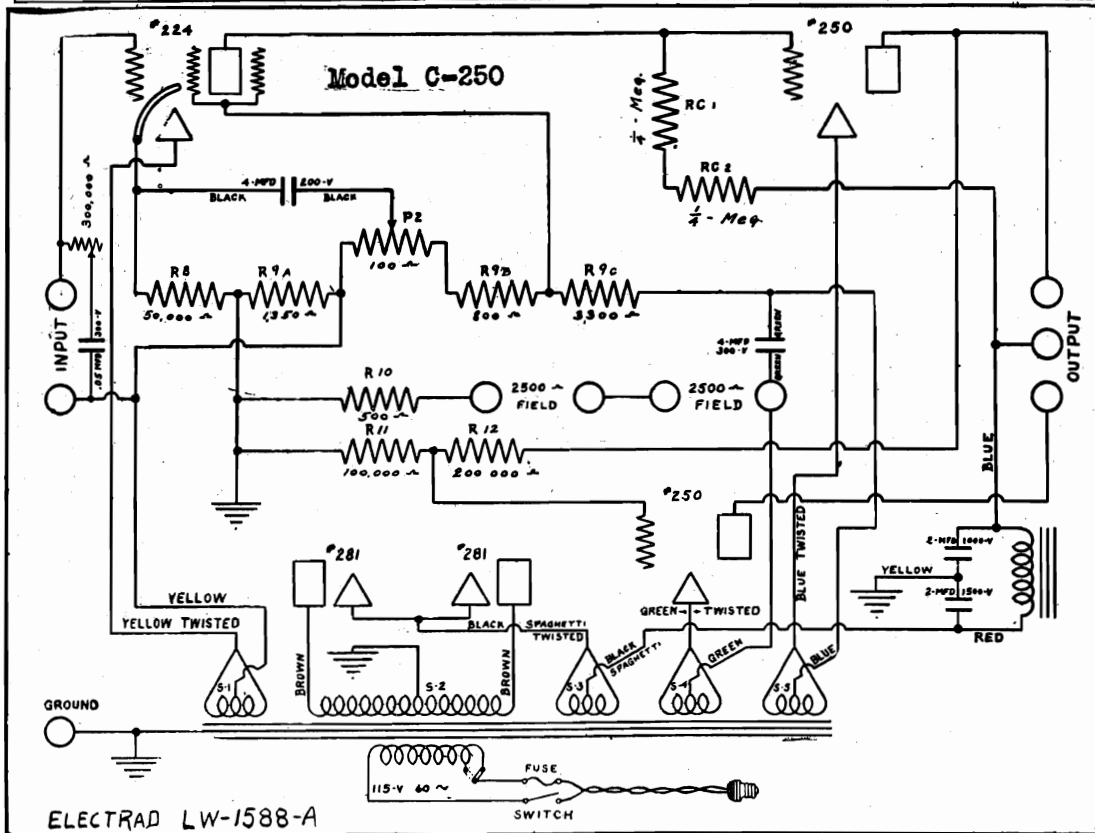

ELECTRAD LW-1588-A

MODEL D-250
MODEL E-250

ELECTRAD, INC.

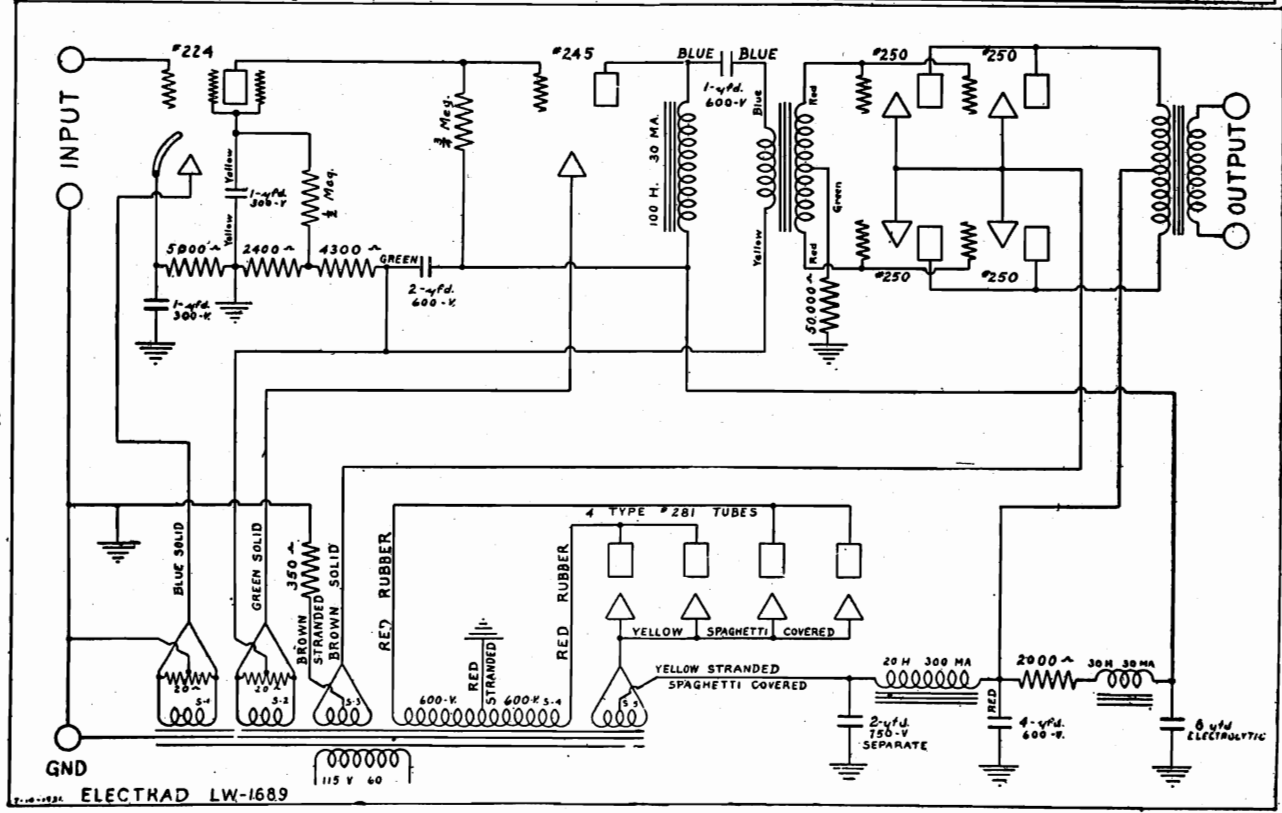
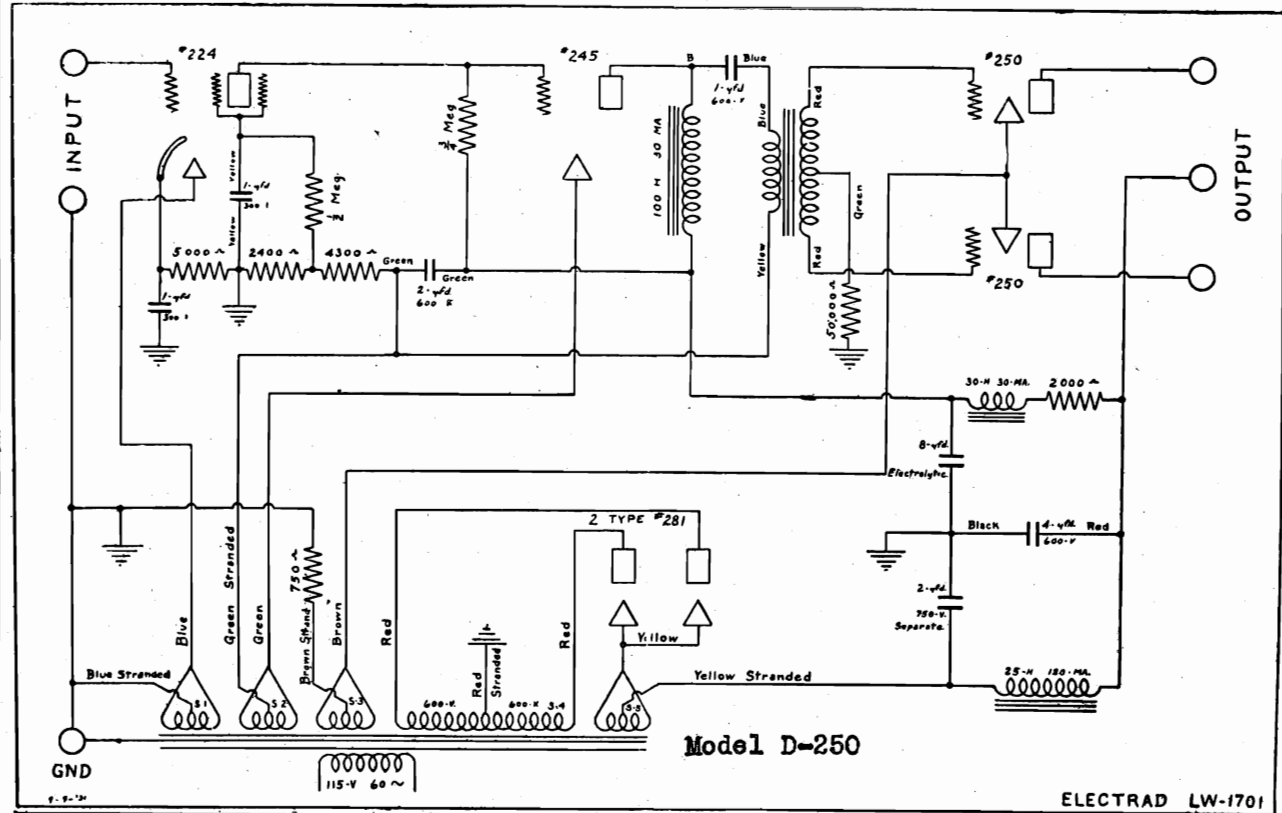

MODEL 74, 76 (210)
Schematic

ELECTRICAL
RESEARCH LABORATORIES, Inc.

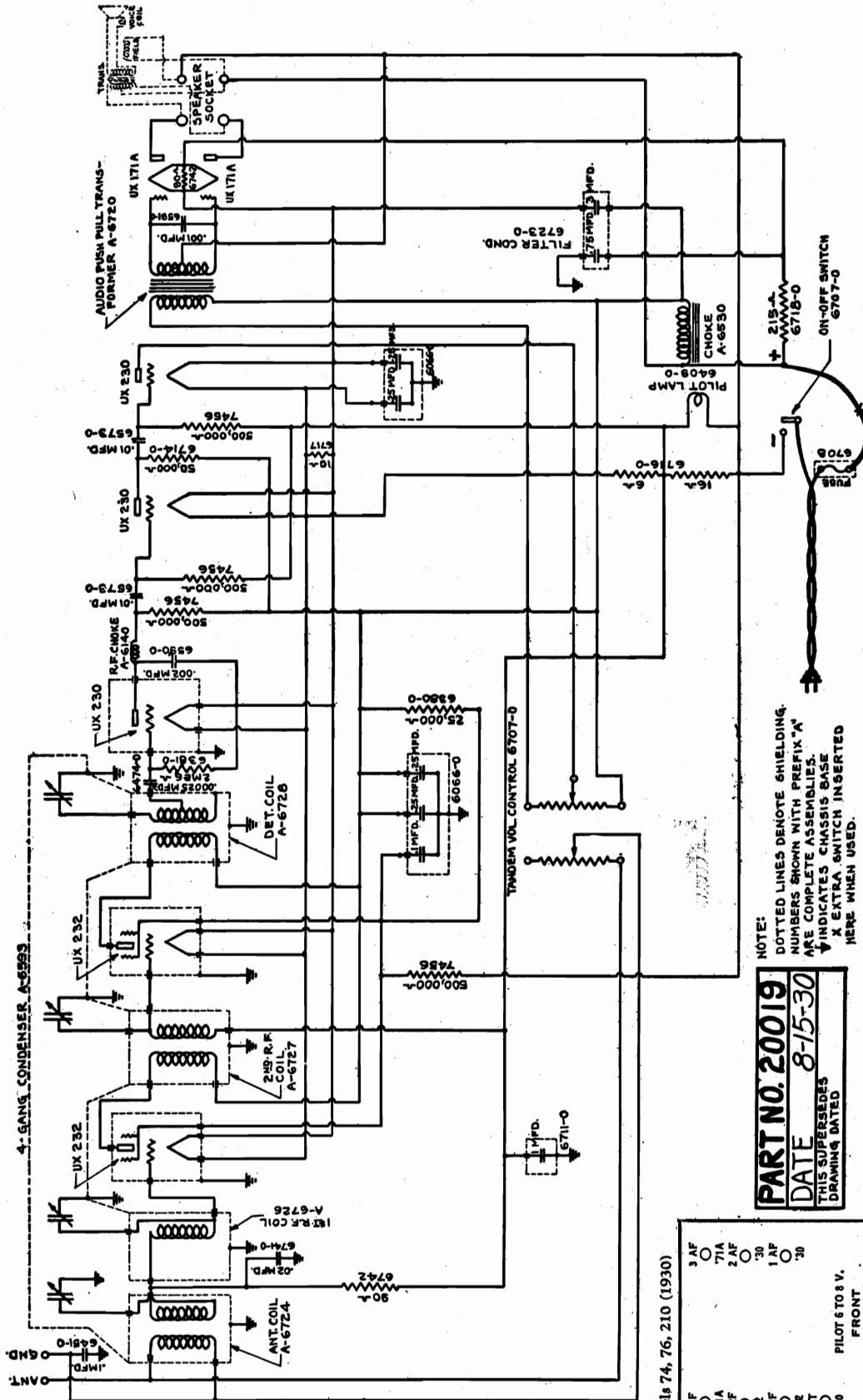

NOTE:
DOTTED LINES DENOTE SHIELDING.
NUMBERS SHOWN WITH PREFIX "A"
ARE COMPLETE ASSEMBLIES.
↑ INDICATES CHASSIS BASE
X EXTRA SWITCH INSERTED
HERE WHEN USED.

PART NO. 20019
DATE 8-15-30
THIS SUPERSEDES
DRAWING DATED

Models 74, 76, 210 (1930)

3 AF	3 AF
1 RF	71A
2 RF	2 AF
DET	30
30	1 RF
	30
	30

PILOT 6 TO 8 V.
FRONT

110 Volt DC.

MODEL 224-B
Schematic

ELECTRICAL
RESEARCH LABORATORIES, Inc.

ERLA MODEL 224-B RECEIVER

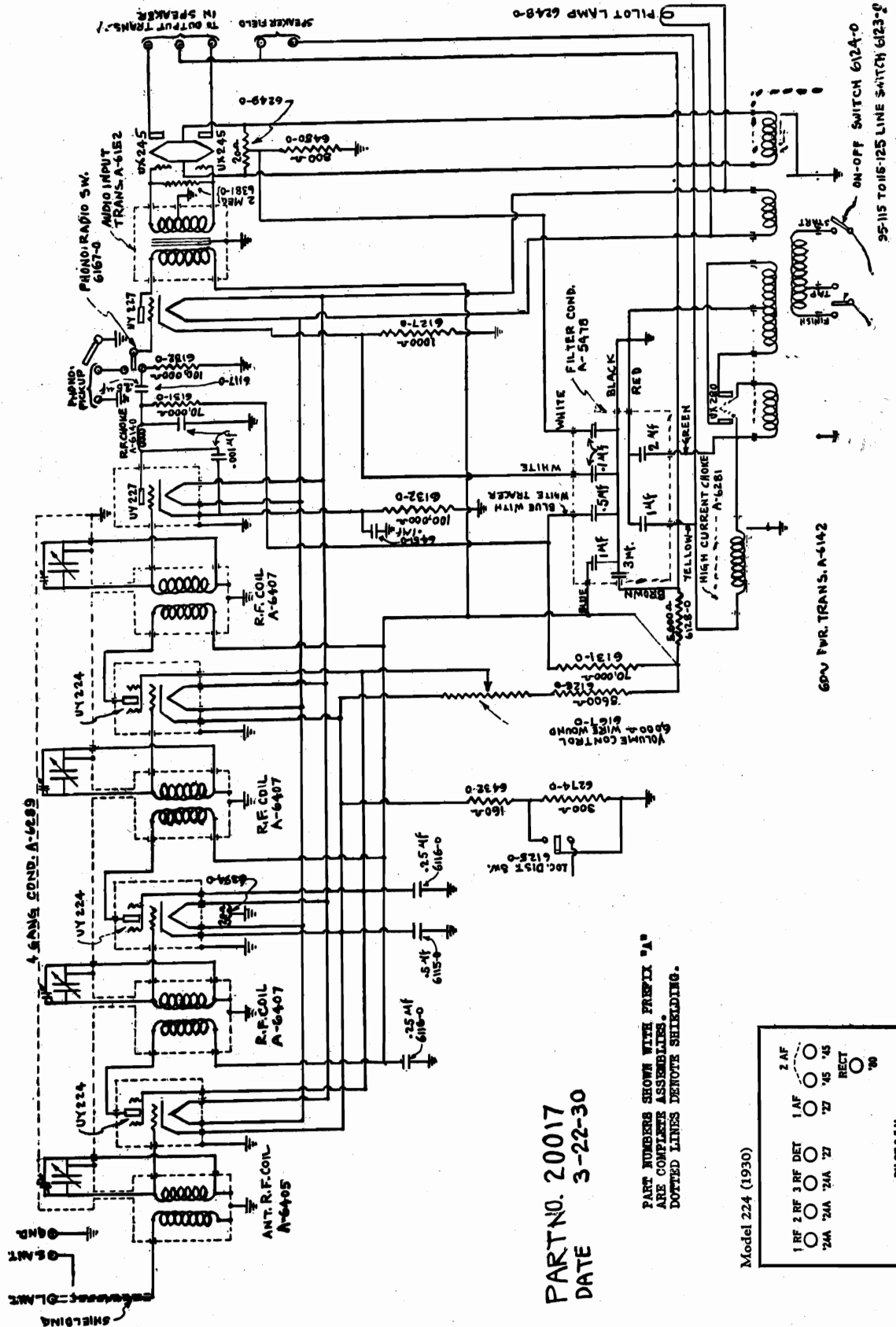

PART NO. 20017
DATE 3-22-30

PART NUMBERS SHOWN WITH PREFIX "A"
ARE COMPLETE ASSEMBLIES.
DOTTED LINES DENOTE SHIELDING.

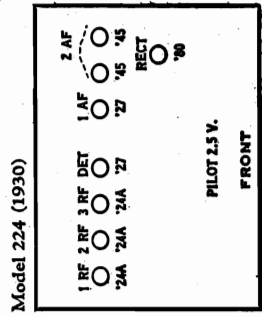

MODEL 225
Schematic

ELECTRICAL
RESEARCH LABORATORIES, Inc.

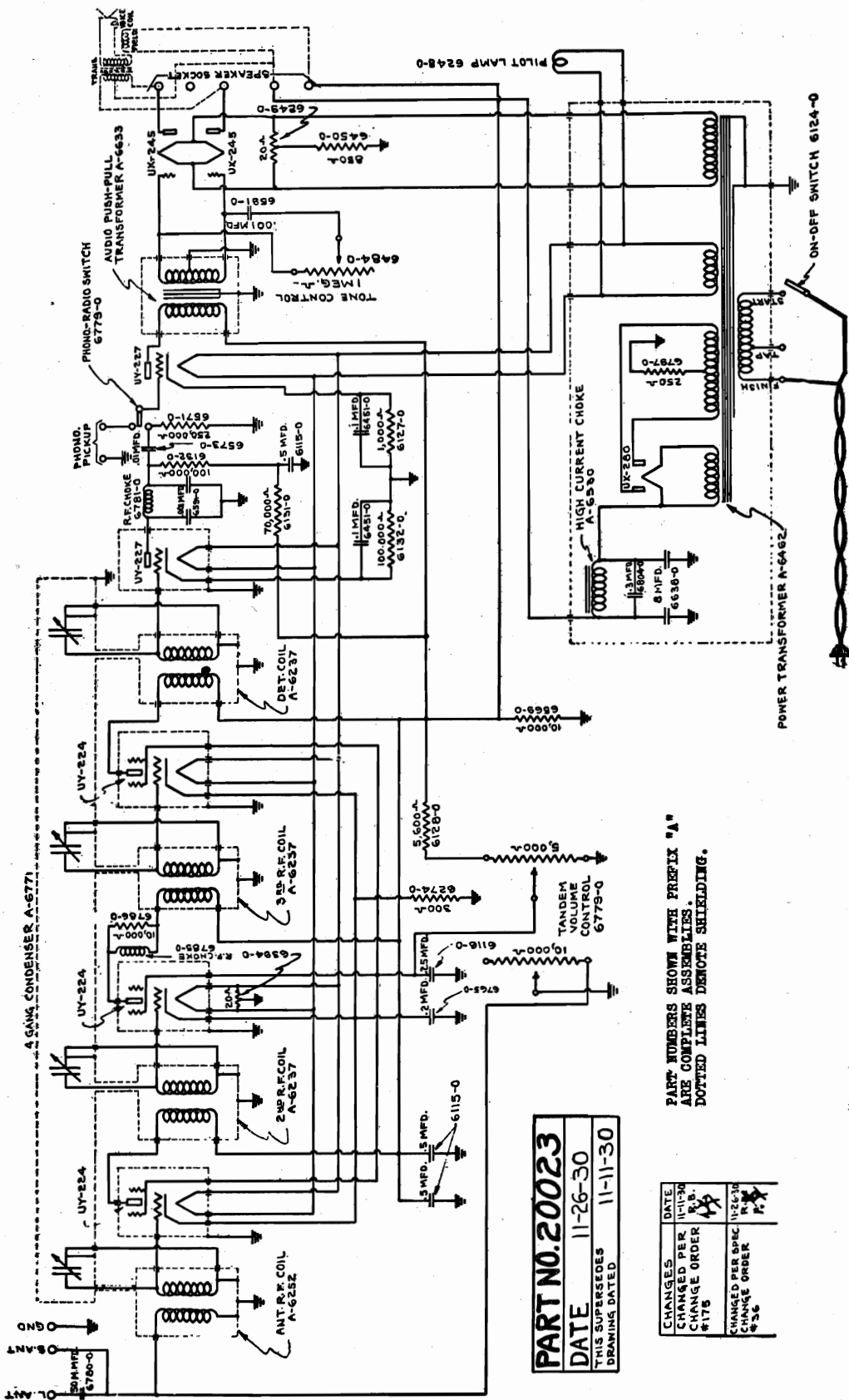

PART NUMBERS SHOWN WITH PREFIX "A"
ARE COMPLETE ASSEMBLIES.
DOTTED LINES DENOTE SHIELDING.

PART NO. 20023
DATE 11-26-30
THIS SUPERSEDES DRAWING DATED 11-11-30

CHANGES	DATE
CHANGED PER R.B. CHANGE ORDER #175	11-11-30
CHANGED PER SPEC. CHANGE ORDER #36	11-26-30

ERLA MODEL 225 RECEIVER

MODEL 271-A
Schematic

ELECTRICAL
RESEARCH LABORATORIES, Inc.

ERLA MODEL 271-A RECEIVER

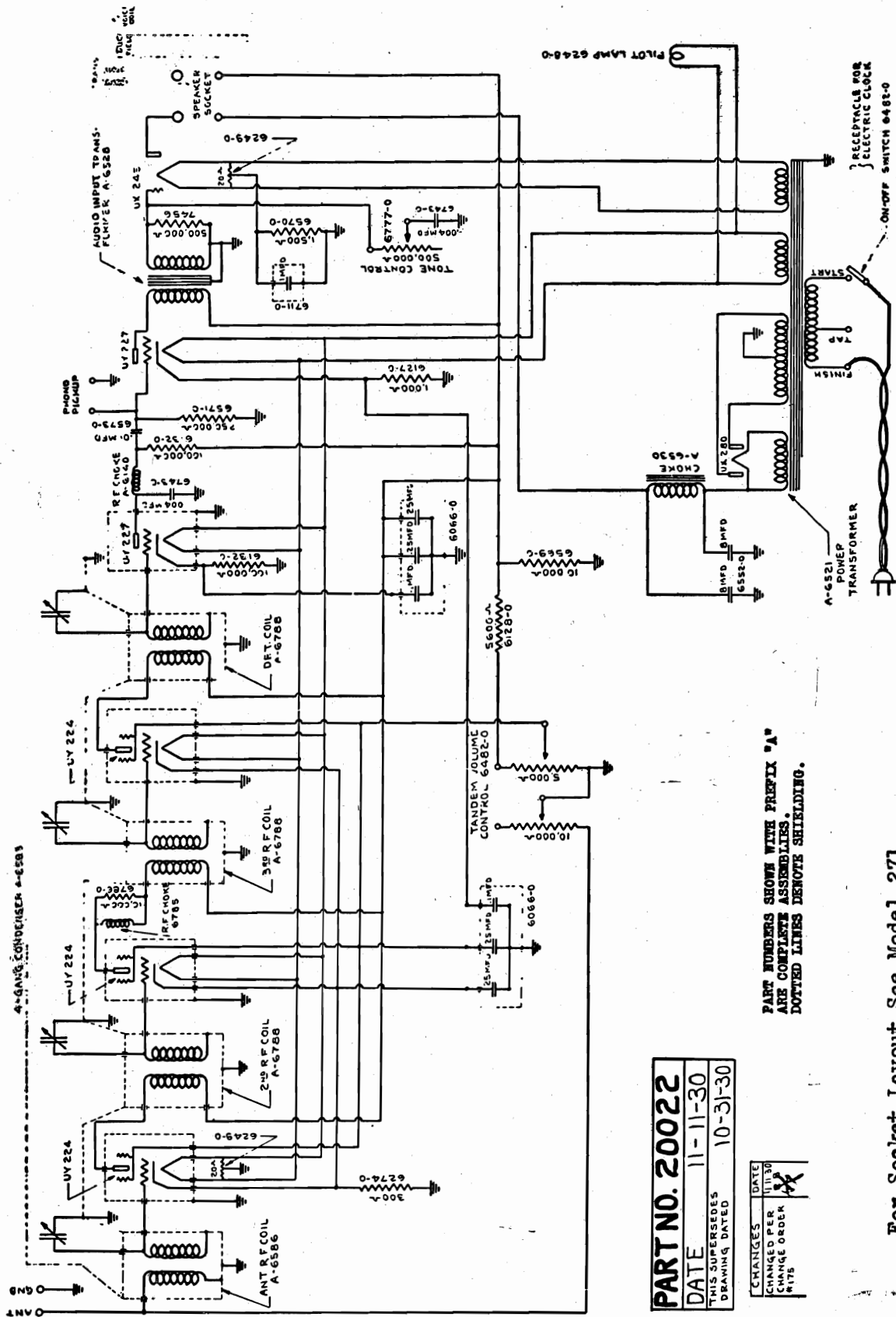

PART NUMBERS SHOWN WITH PREFIX "A"
ARE COMPLETE ASSEMBLIES.
DOTTED LINES DENOTE SHIELDING.

PART NO. 20022
 DATE 11-11-30
 THIS SUPERSEDES
 DRAWING DATED 10-31-30

CHANGES	DATE
CHANGED PER ENGINE ORDER #175	11/30

For Socket Layout See Model 271

FADA RADIO & ELECTRIC CORP.

MODEL 10,11,30,31
MODEL 10Z,11Z,30Z,31Z
Notes

NEUTRALIZING AND COMPENSATING INSTRUCTIONS FOR
Fada 10, 11, 30, & 31 Receivers - 60 cycles
Fada 10Z,11Z,30Z,& 31Z Receivers - 25 cycles

NEUTRALIZATION: The first neutrodon is located to the right of the 1st RF tube; the second neutrodon is in front and slightly to the right of the 2nd RF tube; the third neutrodon is directly between the 3rd RF and detector tubes. The neutrodons are numbered according to their respective RF stages. The tube positions are indicated on the card attached to the cabinet lid or back, or back drop door in console model. The use of headphones is strongly recommended.

1. Tune in a strong low wave station or local oscillator of about 250 to 300 meters.
2. Remove the 3rd RF tube and insert a dead tube (a good tube with one heater prong cut off close to base)
3. Using the Fada special adjusting tool (part No. 1356-Ms) turn the third neutrodon to the left or right to point of MINIMUM signal. Replace the live tube.
4. Repeat operations 2 and 3 in the second and first RF stages.

COMPENSATION: Turn the tuning control towards the 100 degree mark until the edges of the rotor plates on tuning condensers two and three (numbered from left to right facing front of set) are exactly flush with the stator plates. Next, using the vernier knob set the rotor plates of the first condenser flush with the stator plates. **DO NOT MOVE THE VERNIER KNOB DURING REMAINING OPERATIONS.** The compensating condensers are mounted on the top of each tuning condenser. They are adjusted by using a socket wrench on the large nut. After the adjustment has been completed the large nut should be held with a flat open end wrench while the small lock nut is tightened with a socket wrench. These wrenches do not need to be insulated. The small lock nut should be removed before starting to compensate.

1. Using headphones if possible, tune in a weak low wave station of about 250 to 300 meters.
2. Adjust each compensating condenser by turning the large nut either to the left or right to point of MAXIMUM signal. As the signal increases during the compensation it should be reduced by the volume control so that small changes in the compensating condensers will be effective on the ear.

The order of compensating is immaterial. If the maximum points are not pronounced enough, decrease the dial setting by about one or two degrees and bring the signal back to maximum with the compensating condensers. Check the set for performance over entire range. Always recompensate whenever the setting of a neutrodon is changed.

FADA RADIO & ELECTRIC CORP.

MODEL 16,17,32
 MODEL 16-Z, 32-Z
 Notes

NEUTRALIZING AND COMPENSATING INSTRUCTIONS FOR
FADA 16, 17 & 32 RECEIVERS - 60 CYCLES
FADA 16-Z & 32-Z RECEIVERS - 25 CYCLES

NEUTRALIZATION: There are three neutrodon, one for each rf stage, each numbered to correspond with the stage neutralized, located as follows - 1st between 1st & 2nd rf tubes - front row, that is second and third tubes from electric unit; 2nd between 2nd and 3rd rf tubes, and 3rd between 3rd rf tube and detector.

To neutralize receiver, substitute head phones for loud speaker and proceed as follows: -

- 1st Carefully tune receiver to strong station or local oscillator at 250 to 300 meters.
- 2nd Remove 3rd rf tube and substitute a dead tube (prepared by cutting off one heater prong of a good tube close to base.)
- 3rd Using special Fada adjusting tool (Part No. 1356-Ms) adjust neutrodon to position of minimum signal. Replace live tube.
- 4th Repeat procedure on two remaining rf stages.

COMPENSATION: The compensating condensers are located on the top of their respective tuning condensers. They are adjusted by using a socket wrench on the large nut. After completing the adjustment, the large nut should be held with a flat open-end wrench while the small lock-nut is tightened with a socket wrench. Since the movable plate is at ground potential, it is not necessary to insulate wrenches. The first tuning condenser (nearest electric unit) holds the antenna compensator which is adjusted by means of its knurled nut.

To compensate receiver, substitute head phones for loud speaker and proceed as follows: -

- 1st Carefully tune receiver to weak station or local oscillator at 250 to 300 meters by adjusting tuning control knob.
- 2nd Beginning with antenna compensator carefully adjust each compensator for maximum volume. (It is always good practice to keep the volume control set at maximum when compensating.)
- 3rd After receiver has been compensated in accordance with above instructions, carefully retune and repeat the procedure.

1225-Ms	.25 mfd (across 16-Z speaker field)
1341-Ms	Carbon - 20,000 ohms (green)
1418-Ms	.25-.25 mfd - 200-400 volts (3 term)
1477-Ms	.000125 mfd - grid (Mld.Mica)(green dot)
1478-Ms	.001 mfd - detector (Mld.Mica) (yellow)
1485-Ms	Pilot lamp - 6 volts (orange)
2-1256-Ms	.0125 mfd- tubular (yellow dot)
2-1299-Ms	Carbon- 250 ohms (light brown)
2-1300-Ms	Carbon- 750 ohms (green)
2-1303-Ms	6,000 ohms (3 conn)(antenna circuit)
2-1307-Ms	Condenser - .07 mfd
2-1308-Ms	Carbon - 5,000 ohms (orange)
2-1316-Ms	3,000 ohms (red dot)(cathode circuit)
2094-Y	Choke - 1,400 ohms

Sensitivity Adjustment On Fada 35B

A sensitivity adjustment is incorporated in the FADA 35B. The adjustment appears as a neutrodon (which must be adjusted) with special neutralizing tool part number 1356MS located between the detector tube and the fourth r.f. coil as shown in sketch. The receiver is adjusted at the factory for best operation on an average antenna. Under no circumstances should this adjustment be disturbed until:

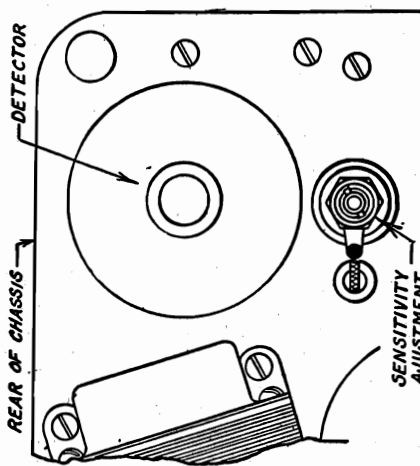

The sensitivity adjustment effects long wave (i. e. 350 meters to 550 meters) sensitivity and selectivity. Turning the adjustment to the right (i. e. down) increases circuit reaction and consequently long wave sensitivity and selectivity. Turning the adjustment to the left (i. e. up) decreases circuit reaction and consequently long wave sensitivity and selectivity. To make sensitivity adjustment proceed as follows:

Make sure the receiver, tubes, antenna and ground are right. Carefully compensate for antenna in use following instructions of receiver instruction sheet. Carefully tune receiver to long wave station (above 500 meters). Turn volume control to maximum. Turn adjustment up or down as required a short distance (say one half turn at a time) and tune thru station noting swish as station is tuned in and out. Adjust to desired point being sure receiver does not squeal (i. e. oscillate).

The Fada 35-B has a hum adjustment located on the rear of the receiver chassis near the phonograph jacks. This adjustment appears as a small shaft with a slot adapted for a screw driver. This is sealed with ambroid after being adjusted at the factory, but the seal may be broken if installation conditions warrant. To adjust receiver for minimum hum, insert screw driver in slot and turn slightly to right and left to position of minimum hum. During this operation the volume control must be turned to zero and the power line plug must be inserted in the socket in the position of minimum hum

Sensitivity Adjustment Fada-25 Receiver

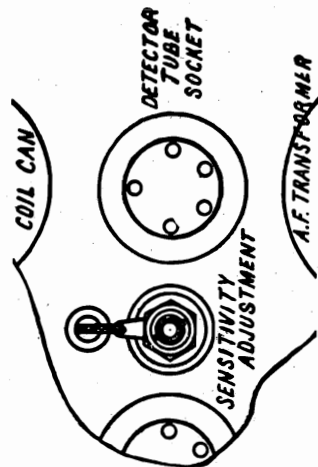

Present production FADA-25 receivers incorporate a sensitivity adjustment. Adjustment is made with a special neutralizing tool part number 1356MS. Facing the rear of the receiver there appears a row of three neutrodons between the r.f. tube sockets. The one on the extreme right, however, is not connected to the usual neutralizing circuits, but is a sensitivity adjustment. Turning this neutrodon up (i. e., to the left) results in minimum circuit reaction and in a more stable receiver. Turning this neutrodon down (i. e., to the right) increases circuit reaction, and consequently sensitivity and selectivity. Advancing this neutrodon too far (i. e., down to the right) will cause long wave oscillation. Maximum sensitivity and selectivity occur when the receiver is adjusted almost to the point of oscillation.

Care should be exercised to insure that everything is in order before the sensitivity adjustment is moved. This adjustment must never be advanced to a point at which sustained oscillation occurs. This adjustment is a useful tool only when carefully used—never attempt to make up for poor compensation or defective tubes.

FADA RADIO & ELECTRIC CORP.

MODEL 40
NotesCOMPENSATING INSTRUCTIONS FOR
FADA 40 Receiver - 60 CYCLES ONLY

The compensating condensers are located on the top of their respective turning condensers. They are adjusted by using a socket wrench. Since the movable plates are at ground potential it is not necessary to insulate the wrench.

The first tuning condenser on the extreme right (facing rear of Receiver) holds the antenna compensator which is adjusted by its knurled nut.

The static shield which is mounted on four studs, should be removed by loosening the four thumb nuts. This shield has no effect whatsoever on Receiver adjustment, consequently it may be left off during compensation, etc.

INSTRUCTIONS FOR
SENSITIVITY ADJUSTMENT

The sensitivity adjuster appears as a neutrodon (which must be adjusted with special neutralizing tool, part No. 1356-Ms) located between the detector tube and the fourth R.F. coil as shown in instruction sheet which accompanies each Receiver. The Receiver is adjusted at the factory for best operation on an average antenna.

The sensitivity adjustment effects long wave (i.e. 350 meters to 500 meters) sensitivity and selectivity. Turning the adjustment to the right (i.e. down) increases circuit reaction and consequently long wave sensitivity and selectivity. Turning the adjustment to the left (i.e. up) decreases circuit reaction and consequently long wave sensitivity and selectivity. To make sensitivity adjustment proceed as follows:

Make sure the Receiver, tubes, antenna and ground are right. Carefully compensate for the antenna in use, following instructions given in Receiver instruction sheet. Carefully tune Receiver to a long wave station (as near 500 meters as possible). Turn volume control to maximum. Advance the sensitivity adjustment (i.e. tune down to right) a short distance (say one-half turn at a time) and tune through the station, noting the swish as the station is tuned in and out. Continue this procedure until the Receiver squeals (oscillates) and then retard neutrodon until Receiver is just below the point of oscillation (i.e. does not oscillate). This adjusts the Receiver for maximum radio frequency performance. If the Receiver oscillates at long waves before the adjustment of the neutrodon has been altered, the reverse procedure is followed. That is, the neutrodon is retarded (i.e. up to the left) a half turn at a time until the oscillation, noted when turning thru a station, ceases. Oscillation is evidenced by a pronounced squeal or note with changes in pitch as the tuning dial is moved. Do not confuse carrier swish or heterodynes between stations with oscillation.

FADA RADIO & ELECTRIC CORP. MODEL 41,42,44,46,47
(KA)

Voltage

Model 41,42,44,46,47 (KA)

VOLTAGE READINGS ON 60-CYCLE KA RECEIVER

The following voltage readings are to be taken at points beneath the chassis. Be sure that the overall condenser and tube shield housing cover is fastened in place or else oscillation will occur which will affect voltage readings. The speaker field coil must remain connected in the circuit and all tubes must be in their correct sockets, otherwise extensive damage will be done.

1. General Information

Volume Control set at any position but no signal
Voltage regulator tap in high position.

Line Volts	Line Watts	Filament Rect.	Filament Pwr.	Volts Amp.	Plate-Cathode Pwr.	Cathode RF	Detector Det.Amp.	Screen Volts RF
100	78	4.2	2.1	2.1				
110	96	4.8	2.35	2.35				
115	100	5.0	2.5	2.5	233	152	**	85
120	114	5.15	2.6	2.6				
130	132	5.5	2.8	2.8				

** A voltage reading cannot be obtained at the plate prong of the two (2) element detector. The plate voltage reading on the detector amplifier should also be ignored, because to take such a reading, it becomes necessary to shunt the voltmeter across several of the resistances in the circuit and the result is a reading of about 20 volts which will vary in accordance with the intensity of the signal received.

Voltages Across Condenser Block Sections (Line Voltage 115)

1st	2nd	3rd	4th
390	352	280	152

Bleeder Circuit Voltages (Line Voltage 115)

Volts Across 100 ohms	- 2.5	NOTE:- Use a high resistance voltmeter (1000 ohms per volt). Readings may vary slightly due to commercial tolerance allowable in the manufacture of electrical equipment and tubes.
Volts Across 300 ohms	- 10	
Volts Across 800 ohms	- 47.5	
Volts Across 5,000 ohms	- 118	
Volts Across 6,700 ohms	- 53	
Volts Across 13,000 ohms	- 89	
Volts Across Speaker Field	- 72	
Volts Across 400 ohm choke	- 38	

FADA RADIO & ELECTRIC CORP. MODEL 61, 66 (XX)

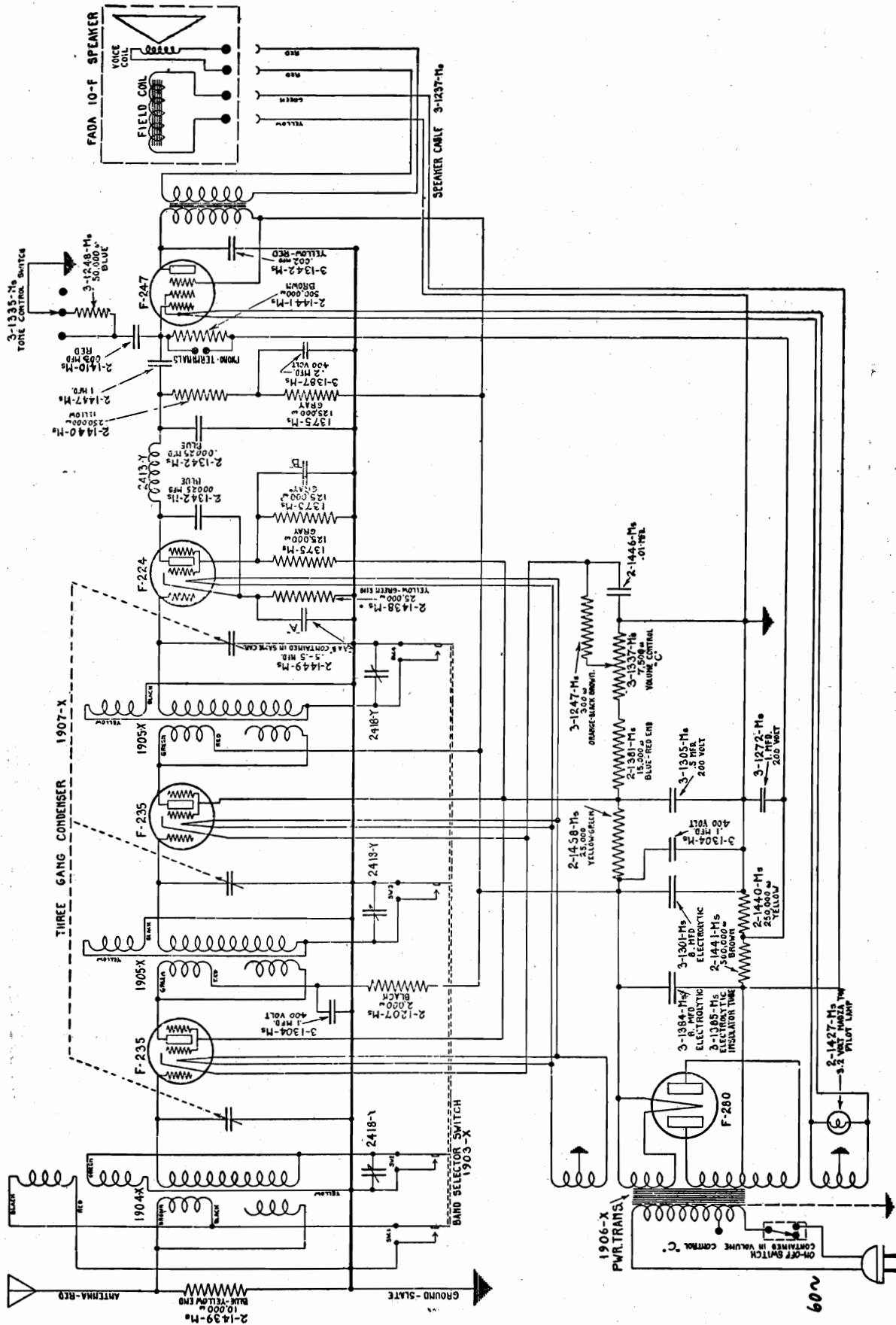

S-2038

FADA RADIO & ELECTRIC CORP.

MODEL 81, 82,
84, 86 (KB)

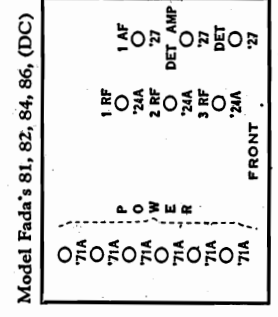
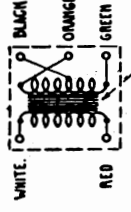
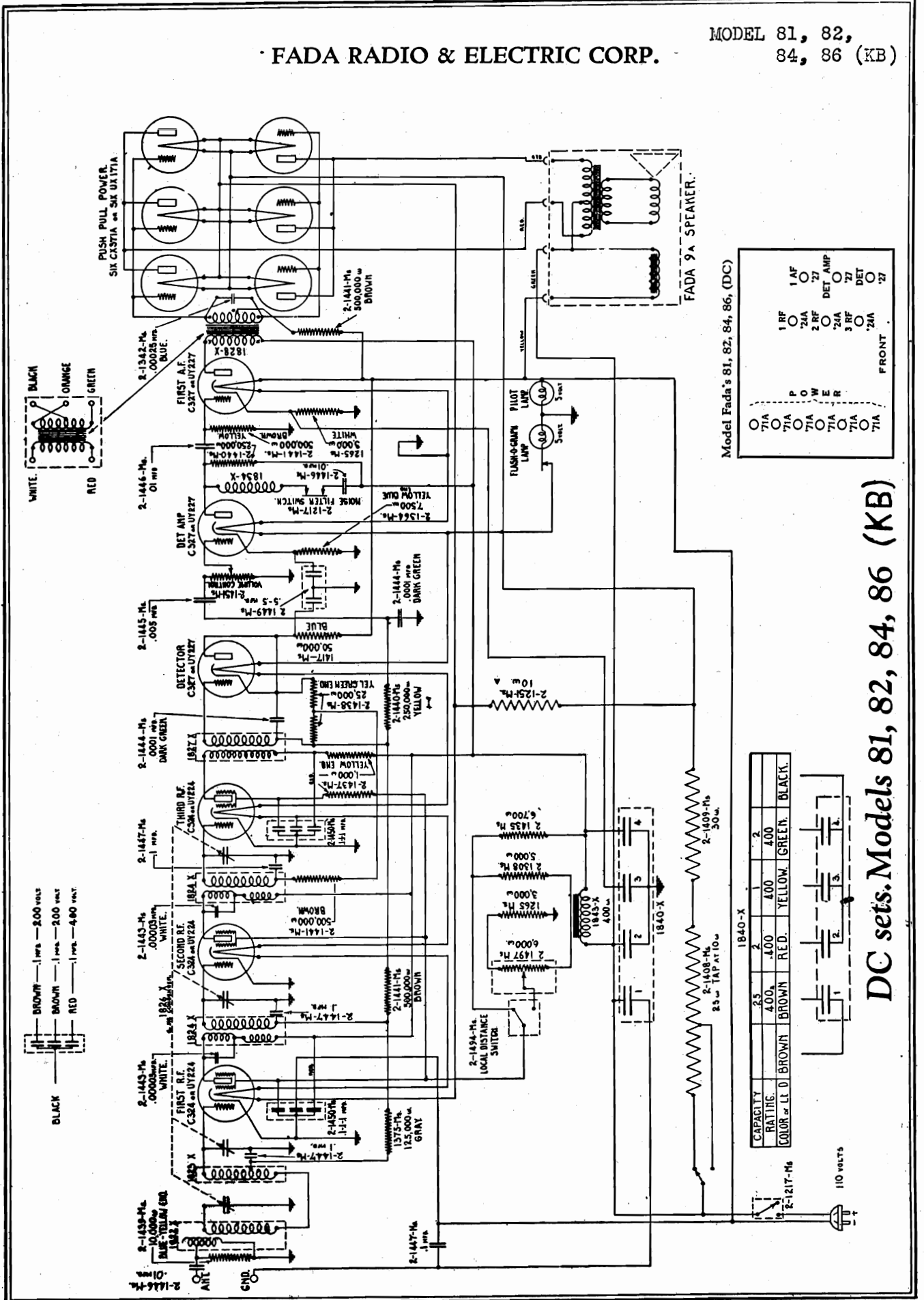

CAPACITY	RATING	COLOR
.25	400	BROWN
.400	400	RED.
1.00	400	YELLOW GREEN.
2.00	400	BLACK.



DC sets. Models 81, 82, 84, 86 (KB)

MODEL 122 (KE)

FADA RADIO & ELECTRIC CORP.

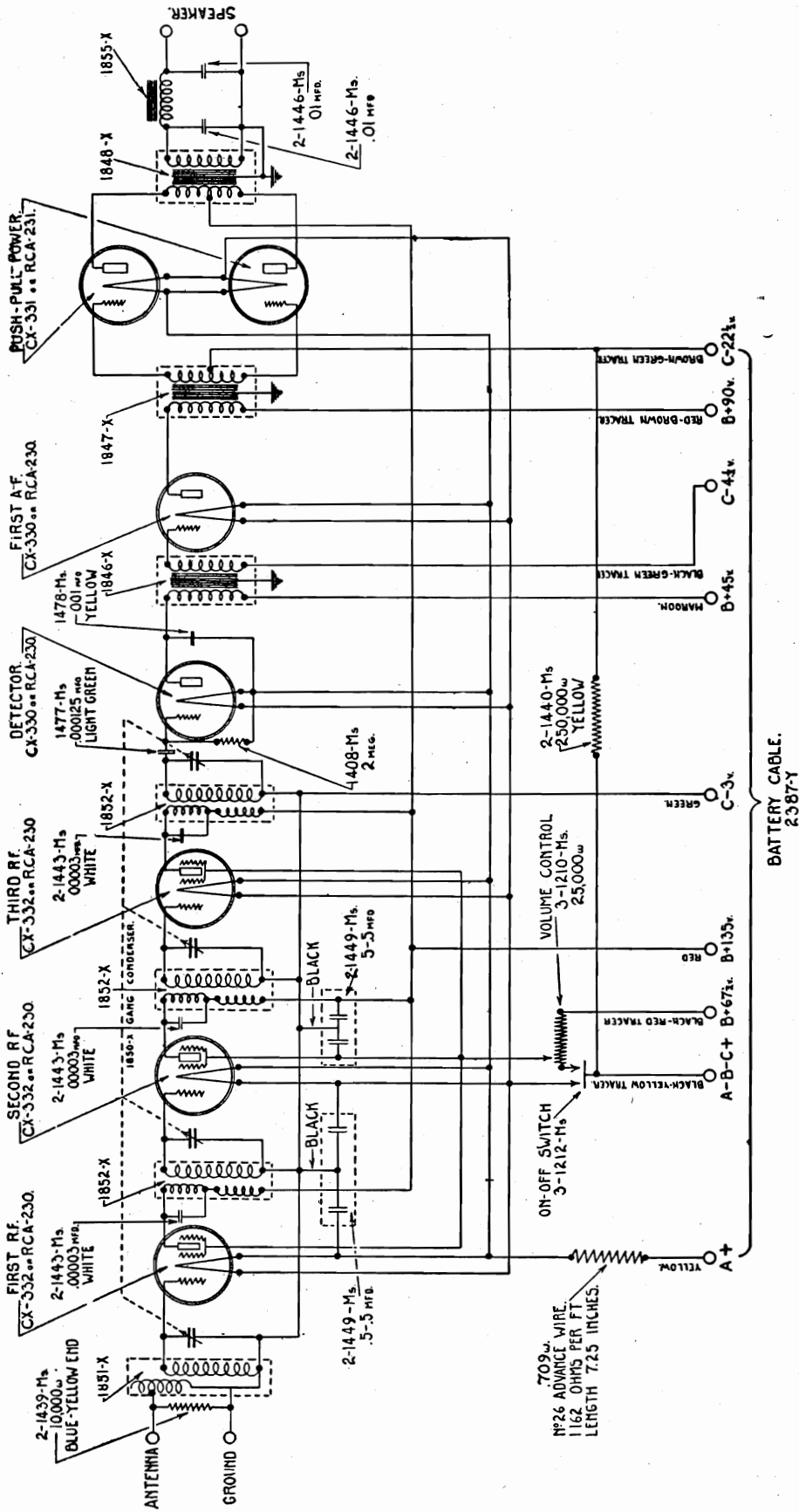

NOTE: GANG CONDENSER (H450-X) HAS 2 TRIMMER CONDENSERS ON 1st, 2nd, AND 3rd, RADIO FREQUENCY STAGES, AND ONE TRIMMER ON DETECTOR TUNING CONDENSER.

BATTERY CABLE.
2587-Y

Model 122, KE

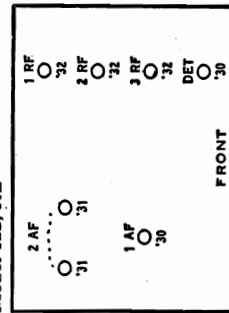

Wiring Diagram Fada Battery Model 122 (KE)

FEDERATED PURCHASER

MODEL Acratone 2
Schematic

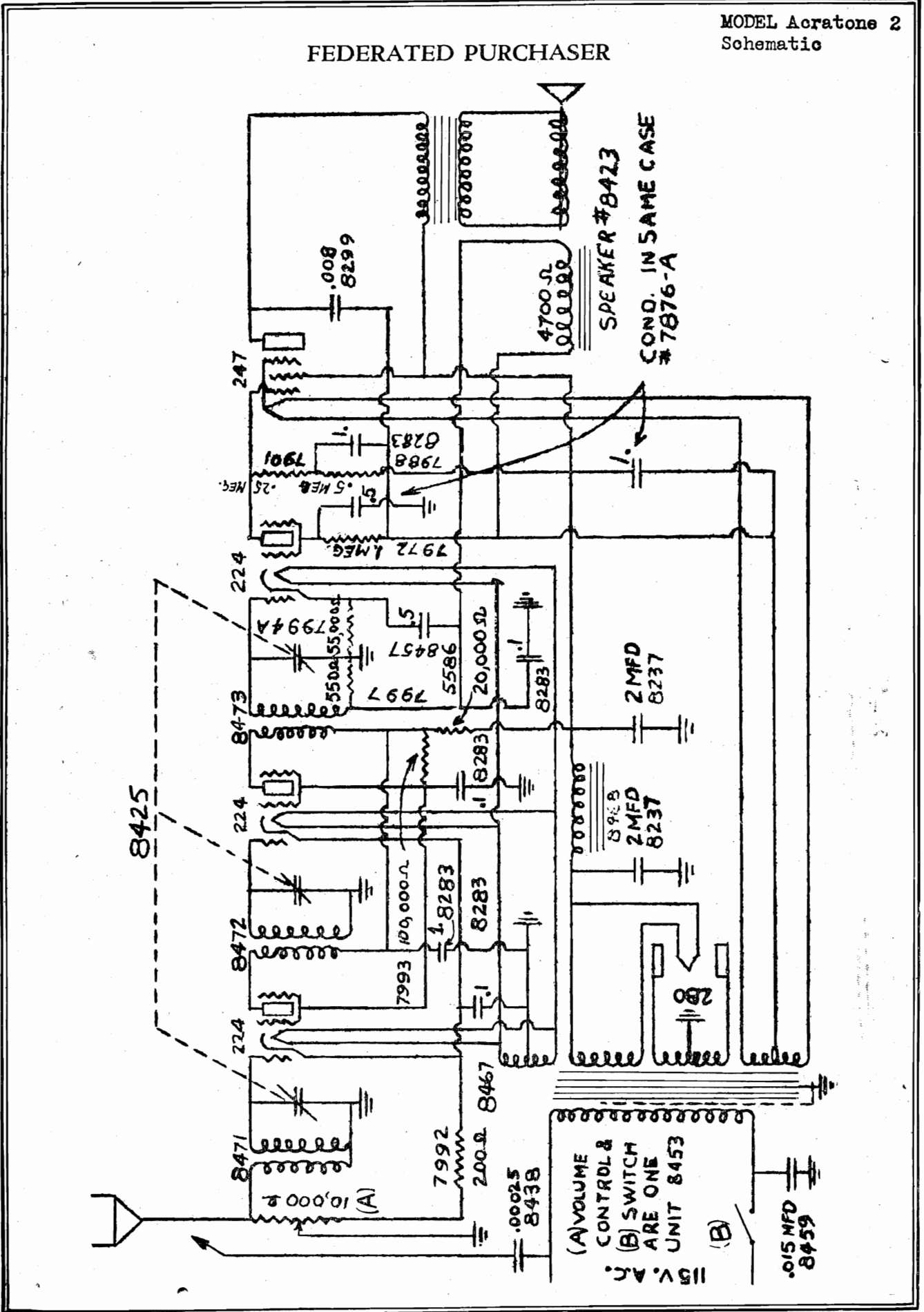

MODEL "G" Junior
Service Notes

JESSE FRENCH & SONS PIANO CO.

JUNIOR MODEL G

Radio Frequency Coils:

The R. F. Coils are of the high reactance type, accurately matched with the condensers.

There are two types of coil sets as well as two types of condenser gangs, and are designated by the markings as follows:

A. The coils used first with precise type condensers, are wound with 116 turns, space wound, and have no color designations on tubing.

B. No. 7829—7830. These coils used with precise condensers, are wound with 122 turns, space wound and have a red mark of paint on base of tubing.

C. No. 8010—8011. These coils used with General instrument condensers, have 126 turns, space wound, have a marking of white paint on base of tubing.

Positions:

Coils No. 8010—7829. The first R. F. coil is located at the front of chassis and is not interchangeable with the second and third R. F. coils.

Coils No. 8011—7830. The second and third R. F. coils are interchangeable and are located in their respective places.

The first R. F. coil differs from the others, as it does not have a choke bucking coil inside of the tubing as the others.

Coil cans are very essential to aid selectivity and reduce interference.

The Condenser Gang:

The tuning condensers are graded in three types.

The condensers can be defined as follows:

The first precise type, have no extended shields between the condensers.

No. 7832. The second precise type have two shields extending between the center and outside condensers.

No. 7872. The general instrument type have four shields and can be easily distinguished from the others.

VOLTAGES

Referring to the Circuit Diagram, the following voltages are given throughout the circuit using straight A. C. or D. C. meters.

CHECK FROM GROUND OF CHASSIS TO POINT DESIGNATED.

GROUND IS NEGATIVE. POINT DESIGNATED IS POSITIVE.

SET VOLUME CONTROL AT MINIMUM.

SET CHASSIS ON ONE END WITH BOTTOM IN VIEW.

Use 600 volt D. C. meter—1000 ohms per volt.

Rectifier filament or choke No. 7825 (beginning).....	440 volts
Choke No. 7825 (ending).....	390 volts
245 power tube plate or choke No. 7735.....	368 volts

Use 300 volt D. C. meter—1000 ohms per volt.

Detector plate or resistor No. 7785 (ending).....	48 volts
R. F. Plate or red wire of condenser No. 7015.....	242 volts
245 grid or resistor No. 7785 (ending).....	48 volts
Detector grid or green wire of condenser No. 7879.....	22 volts
Detector cathode or resistor No. 7786.....	12 volts
R. F. cathode or black wire condenser No. 7015.....	2 volts
R. F. Screen Grid at red wire volume control or at Resistor No. 7783 (end).....	120 volts

USING A WESTON SET TESTER MODEL 537

Volume control set at maxim.

SETTINGS	R. F. TUBES	DETECTOR	AMPLIFIER
PLATE (300)	190 d. c.	55 d. c.	210 d. c.
CATHODE POS.	2 d. c.	65 d. c.	none
FIL. (4)	2.8 a. c.	2.7 a. c.	2.7 a. c.
PL. MA. (30)	none	none.....	25 d. c.
BIAS (c60)	2 d. c.	2 d. c.	12 d. c.

Rectifier pl. ma. (30) 19 D. C.—Fil. volts 4.5 a. c.

Det. grid on 50 volt d. c. meter 12 volts.

R. F. grid on 250 volt d. c. meter 89 volts.

Det. cathode on 50 volt d. c. meter 21 volts.

Line voltage 114 volts a. c.

SPEAKER CONNECTIONS:
A. Yellow No. 4 goes to speaker ground.
B. Black No. 3 goes to speaker field.
C. Black No. 1 goes to speaker field.
D. Red No. 2 goes to output transformer.
E. Red No. 5 goes to output transformer.

SPEAKER SERVICING
The speaker color chart and the respective wiring connections. As follows: Chassis connections:
A. Yellow No. 4 goes to ground of set.
B. Black No. 3 goes to center tap of 245 tube filament, and resistor No. 7784.
C. Black No. 1 goes to No. 7989, 500 ohm resistor and grid return of detector, at R. F. coil.
D. Red No. 2 goes to No. 7782, 10,000 and 7785 resistors.
E. Red No. 5 goes to plate of 245 or No. 7735 choke coil.

JESSE FRENCH & SONS PIANO CO.

MODEL H-2 Pentode
110 Volt AC
MODEL H-2 Special
110 Volt DC

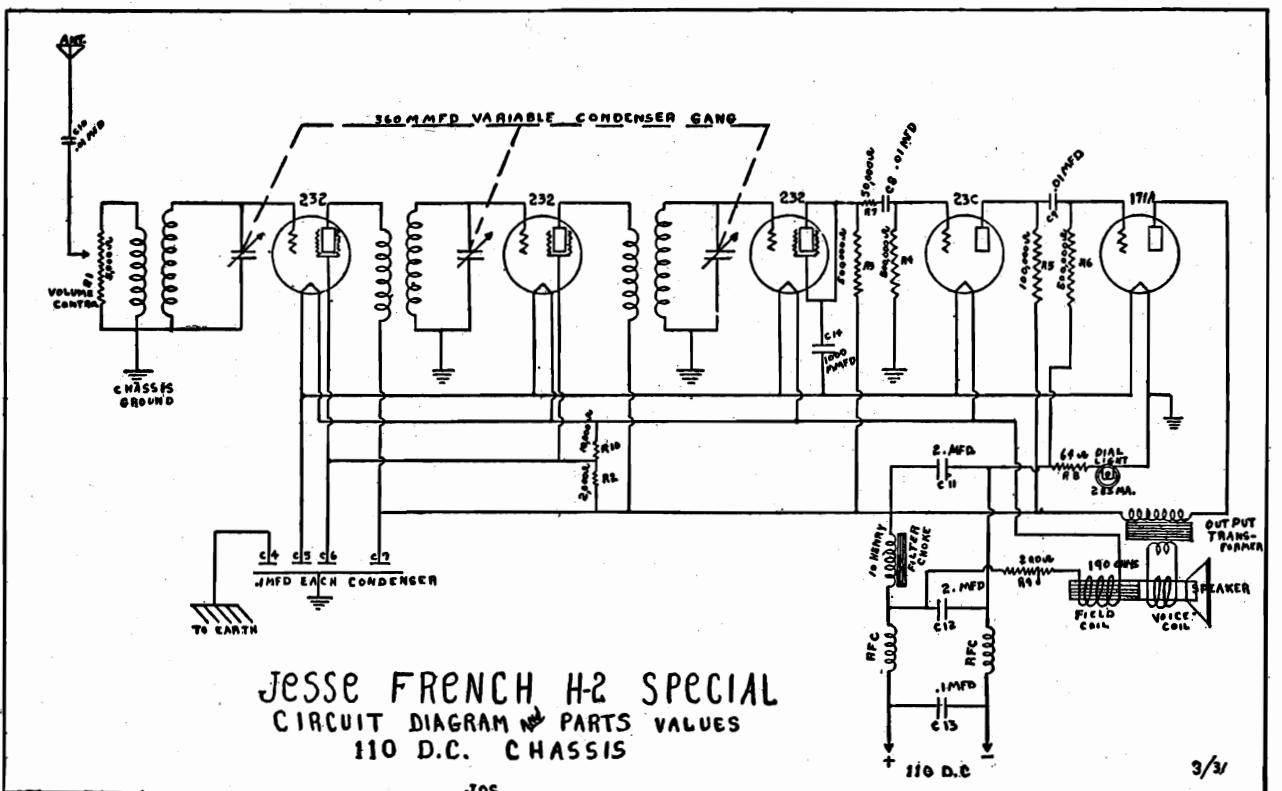
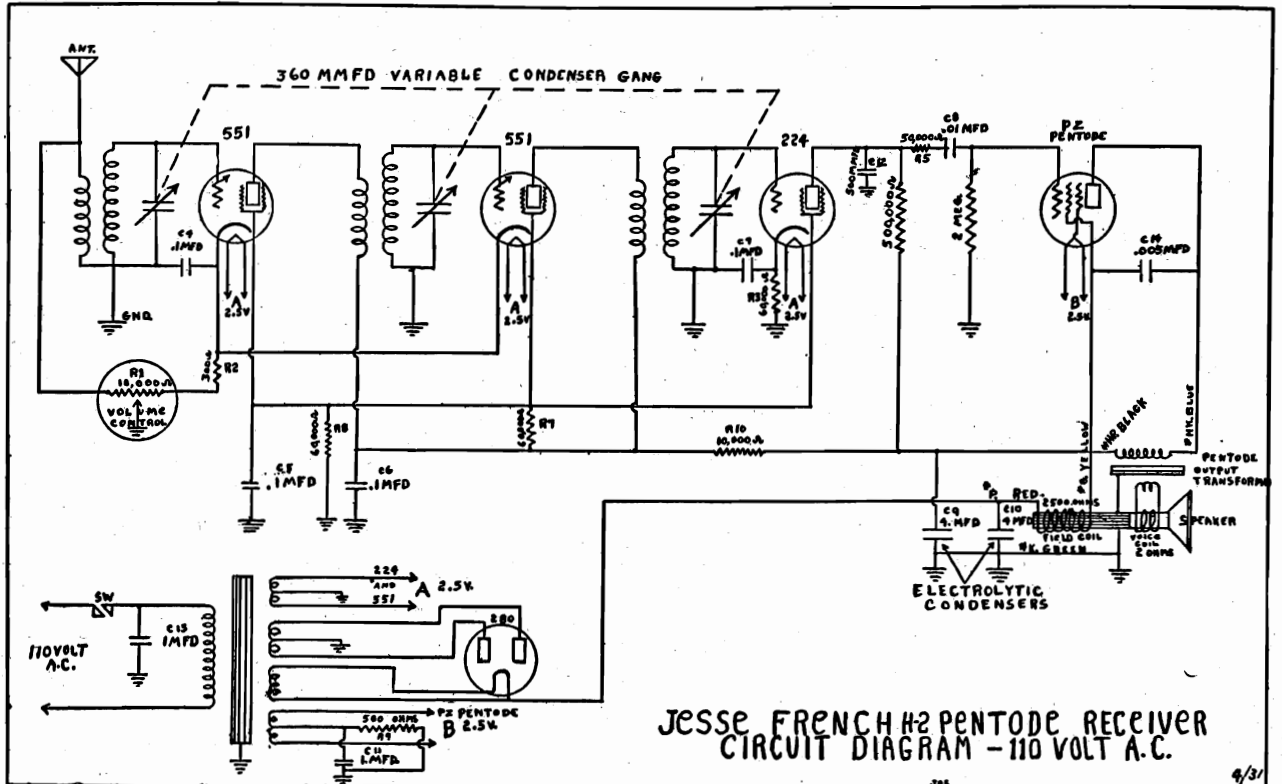

MODEL H-1
Service Notes
MODEL U-1
Service Notes

JESSE FRENCH & SONS PIANO CO.

JUNIOR MODEL H-1

DETECTOR

It is quite a question in the Loftin-White direct coupled amplifier where detection actually takes place, but for the time being, we will call the type 224 tube the detector, and the type 245 tube the audio frequency amplifier. The detector can be considered of the high bias type. A 100,000 ohm resistor in the cathode circuit of the 224 tube connects the cathode approximately 15 volts positive with respect to ground. This is too high a bias for the 224 to operate as a detector. Therefore the grid return is brought back to a position on the network about 12 volts position with respect to ground. This leaves a three volt bias on the grid of the detector which is the proper value for detecting weak signals. When a strong signal is delivered to the grid of the detector, the detector plate current increases. This changes the cathode voltage from 15 volts approximately 20. At the same time, the plate current in the network decreases making the grid returns approximately 8 volts positive with respect to ground. The effective bias on the grid of the detector tube is therefore about 12 volts which is the proper value for detecting the strong signals. In measuring the bias on the detector, the readings will be affected a great deal by the type of volt meter used. It is best for the service man to take these readings on a set which is known to be good with his own volt meter. In the future these readings can be taken as standard and questionable sets compared to them.

AUDIO

The peculiar part of measurements on this audio system is the high voltage from the 245 tube plates to ground, the high voltage from the filament to ground and the impossibility to read the grid voltage with a meter. The best indication of the Loftin-White detector amplifier condition is the plate current of the type 245 tube. This should be approximately 38 milliamperes. This reading will vary quite a bit with different tubes and with the line voltage.

Tube	Filament V	Plate V	Cathode V	Grid V	Plate Current
1st R. F.	2.5	160	3	0	3.
2nd R. F.	2.5	160	3	0	3
Detector	2.5	varies	14	12	.25
Audio	2.5	380	160	varies	40
Rectifier	5				20 ma.

Line Voltage 120—
 All plate voltages are read from plate of the tube to ground.
 All cathode voltages are read from the cathode to ground.
 All grid voltages are read from the grid of the tube to ground.

A special dynamic speaker with a 4700 ohm field coil is used as part of the Loftin-White resistance network.
 The rectifier tube is used as a full wave rectifier and supplies the total plate current of the set which is approximately 38 milliamperes at 400 volts.

THE U-1 SUPERHETERODYNE CIRCUIT

The U-1 Chassis uses seven tubes as follows: one 551 variable Mu tube for the first tuned R. F. stage, one 224 screen grid tube for first tuned detector, with a 227 oscillator tube signal beating into the first detector stage. One 551 Variable Mu tube for the intermediate R. F. stage and a 224 for power detector. This second detector or Power Detector is resistance coupled to the power tube which is a PZ Pentode type tube. One 280 tube is used as a rectifier.

The grid bias of the Pentode is obtained by the center tap of the Rectifier Plate passing through the 1620 ohm field coil to ground instead of leading direct to ground for negative potential. The power grid is tapped into the field coil at 1320 ohms or 300 ohms from ground, making a positive flow to ground. The resistances are so arranged in the grid circuit of this power tube, that it gives excellent tone quality because it presents a constant positive flow to ground of circuit.

A 385 ohm filter choke connects the source of the plate or 280 filament with the plate filter by passes which are of the 8 mfd wet electrolytic type condensers and the remainder of the circuit being by-passed by paper and mica condensers.

The first electrolytic condenser by-passes the plate positive source to the center tap of the rectifier plate winding or negative potential which will have a negative voltage of approximately 83 volts before it passes through the field coil to ground. The body or negative of the electrolytic case being insulated from the chassis permits this by-passing arrangement.

LINE VOLTAGE 110 VOLTS A.C. - VOL. CONTROL AT MIN.

Tubes	227	551	224	551	224	224	PZPentode	280
Plate	95	246	246	98	226	246		278
Screen Grid	none	95	95	30	246			
Cathode	none	37	7.5	37	4.75	0		
Grid	-5.75	0	0	0	0	-1.5		

VOL. CONTROL AT MAX.

Plate	68	240	240	240	94	220		275
Screen Grid	0	68	68	28	240			
Cathode	0	3.5	5	3.5	4.5	0		
Grid	3.4	0	0	0	0	1.5		

The following are the given voltages at the speaker terminals: Brown lead 220 volts - Green lead 240 volts - Black lead 0 - Red lead 14 volts - Yellow lead 83 volts.

Resistors are marked according to the standard E.M.A. color code.

GENERAL MOTORS RADIO CORP.

MODEL Day-Fan A-5005
A-5020
Schematic, Voltage

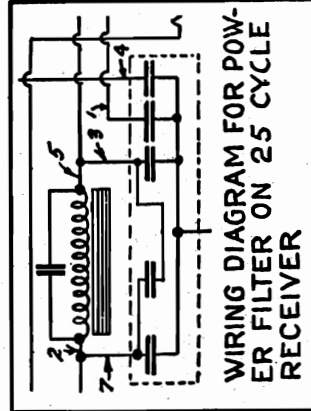
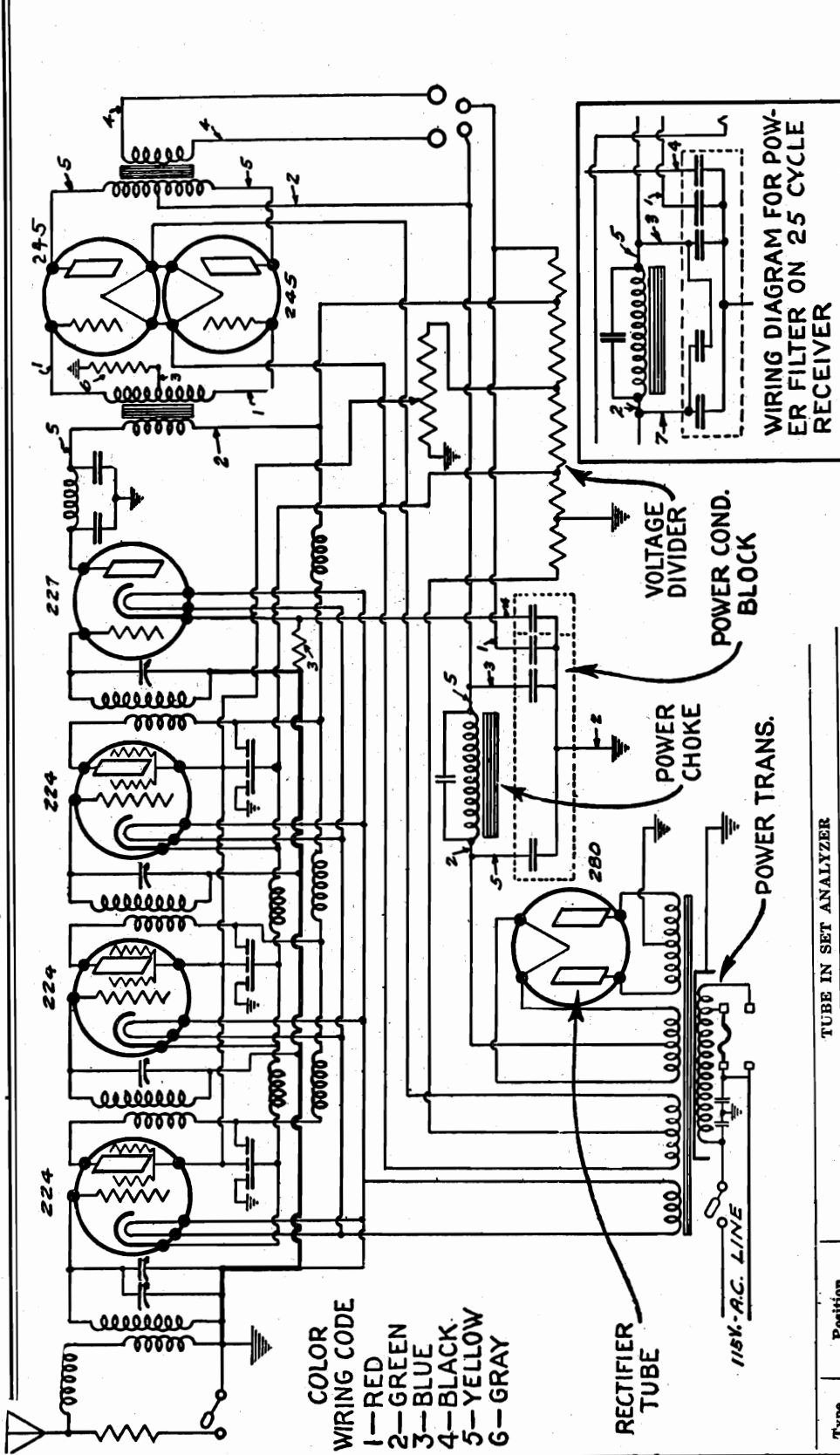

WIRING CODE
1—RED
2—GREEN
3—BLUE
4—BLACK
5—YELLOW
6—GRAY

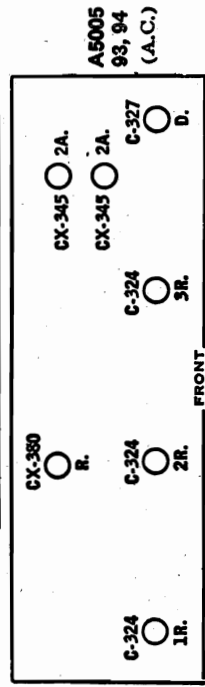

Type of Tube	Position of Tube	TUBE IN SET ANALYZER						Normal Plate Ma.	Gd. Test Ma.
		"A" Volts	"B" Volts	Con. Grid "C" Volts	Screen Volts	Cathode Volts	...		
224	1-R. F.	2.2	145	- 3	+66	+ 3	2.0	4.0	
224	2-R. F.	2.2	145	- 3	+66	+ 3	2.0	4.0	
224	3-R. F.	2.2	145	- 3	+66	+ 3	2.0	4.0	
227	Det.	2.2	130	-13	...	+13	
245	A. F.	2.2	220	- 8	32.0	37.0	
245	A. F.	2.2	220	- 8	32.0	37.0	
280	Rect.	4.4	105.0	...	

Line Voltage During Test —110 Volts
Volume Control —On Full
Position of Fuse —115 Volt Clips

MODEL Day-Fan A-5005
A-5020

Chassis

GENERAL MOTORS RADIO CORP.

DAY-FAN
MODEL A-5005
MODEL A-5020

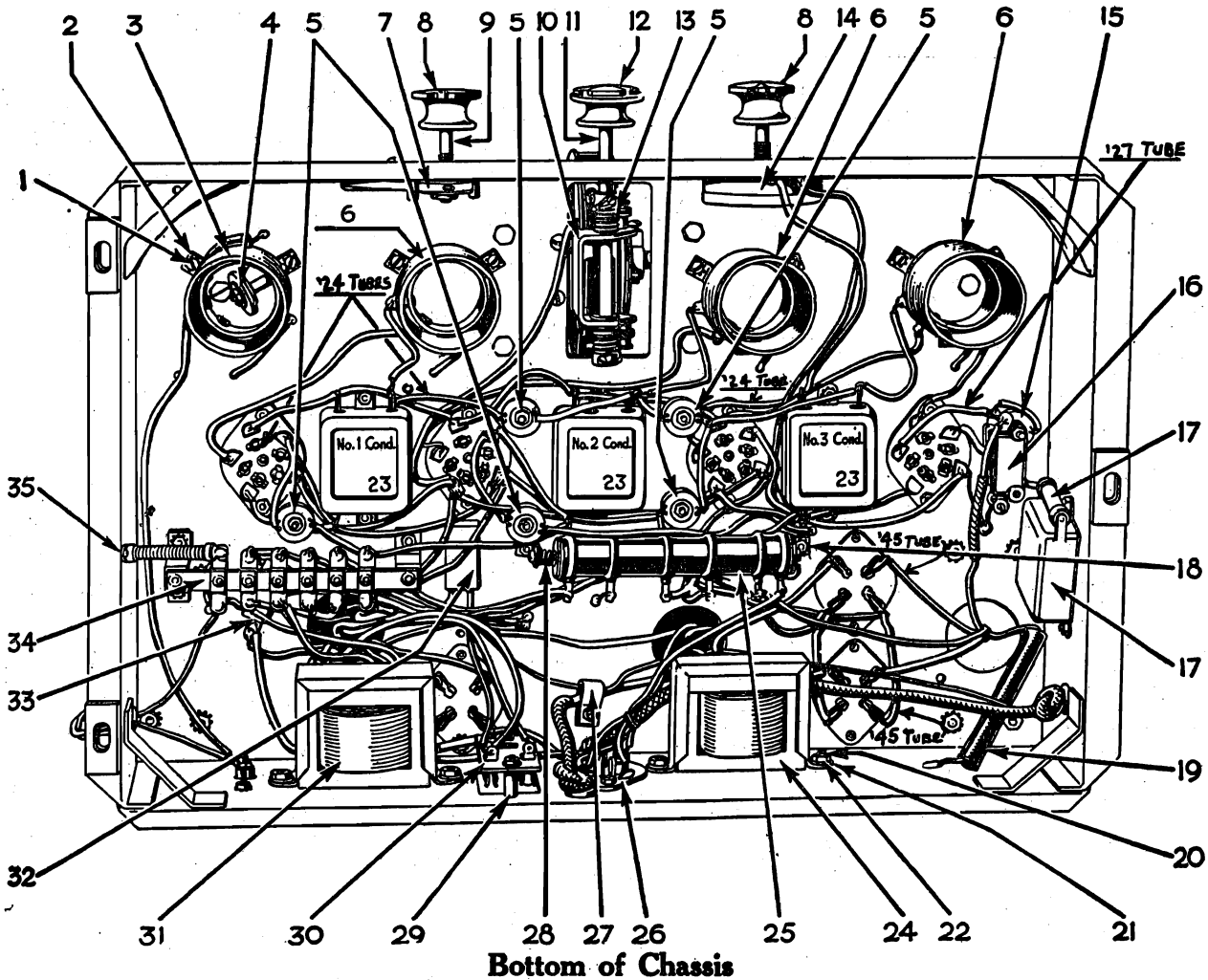

Bottom of Chassis

Illus. No.	Part Number	Description	Illus. No.	Part Number	Description
1	26758	Screw	18	26568	Mounting Bracket
2	138164	Lock Washer	19	1201604	Resistor, 500,000 Ohms
3	14609	No. 1 R. F. Coil	20	21678	Screw
4	14650	Antenna Coil	21	138475	Shake-proof Washer
5	14556	Choke Coils	22	25591	Nut
6	14603	No. 2, 3, 4 R. F. Coils	23	1200473	Condenser, .1-.1-.1 Mfd.
7	14766	Trimmer Drive Pulley & Pin	24	14597	Output Transformer
7	26682	Belt	25	1200167	Voltage Divider
8	14351	Knob	26	14594	Speaker Plug Receptacle
9	26679	Trimmer Shaft	27	24981	Strap
10	14591	Selector Bracket Assem.	28	26562	Spring
11	26175	Selector Shaft	29	24901	Spacer
12	14664	Knob-Tuning Condenser	30	1200195	Fuse Block Assem.
13	14662	Windlass	31	1200135	Power Choke
14	14588	Volume Control	32	14738	Line By-Pass Condenser
15	14556	Det. Plate Choke	33	13075	Condenser
16	1200413	Condenser	34	14566	Terminal Strip Assem.
17	1201610	Resistor, 25,000 Ohms	35	14624	Local and Distance Resistor.
17	14686	No. 4 Condenser			

GENERAL MOTORS RADIO CORP.

MODEL 120, 130, 140
Service Notes

MODELS 120, 130 and 140 CHASSIS MODELS "A" and "B"

The Models "A" and "B" chassis are divided into three groups having slightly different circuits.

Serial Numbers below 29100A and 1700B:
In the original models, with serial numbers below approximately 29100A and 1700B, one side of the Dual Volume Control is in the antenna coil, with a .0005 mfd. condenser between the antenna and the antenna choke.

The other side of the volume control, together with a 5000 Ohm resistor is in the screen grid circuit of the R. F. stages. In these sets there are two R. F. chokes in the cathode circuit of the R. F. tubes.

Sets with this circuit can be distinguished by the presence of five similar R. F. chokes, one being located near the first 224 tube socket, and four between the second and third 224 tube sockets.

Sets having the "capacity coupled" R. F. coils can be distinguished by the presence of three R. F. chokes, one can be distinguished by the presence of the Electrolytic Condensers.

Sets above 62100A and 1964B can be distinguished by the presence of the Electrolytic Condensers.

Serial Numbers between 29100A and 62100A, Model "B" Chassis:
The circuits of sets with serial numbers above approximately 29100A and 1700B, one side of the Dual Volume Control is in the antenna coil, with a .0005 mfd. condenser between the antenna and the antenna choke.

The other side of the volume control, together with a 5000 Ohm resistor is in the screen grid circuit of the R. F. stages. In these sets there are two R. F. chokes in the cathode circuit of the R. F. tubes.

Sets with this circuit can be distinguished by the presence of five similar R. F. chokes, one being located near the first 224 tube socket, and four between the second and third 224 tube sockets.

Sets above 62100A and 1964B can be distinguished by the presence of the Electrolytic Condensers.

Sets having the "capacity coupled" R. F. coils can be distinguished by the presence of three R. F. chokes, one can be distinguished by the presence of the Electrolytic Condensers.

Trimmer Adjustment on Tuning Condensers:
A small Trimmer Condenser is located on each of the four variable condenser units which comprise the Gang Tuning Condenser. The trimmer screws may be adjusted by means of screw-driver through the holes in the top of condenser shield.

The No. 1 Trimmer (Left side when viewed from the front) should be adjusted when the set is installed as it balances the antenna stage to meet the requirements of the antenna used. This Trimmer should be adjusted by tuning a station whose frequency is at the high end of the scale, near 1400 Kilocycles, No. 2, 3, and 4 Trimmers should be adjusted only when the complaint is very definitely lack of volume or broad tuning.

If the sensitivity or selectivity is not normal, the Trimmers should be adjusted before attempting to calibrate the Tuning Condenser. To adjust the Trimmers, tune in a station around 1400 Kilocycles and turn the volume down by means of the volume control until the station is just audible.

Start with the Trimmer which is on the left side of the chassis, when viewed from the front and adjust the screw either to the right or left until the loudest signal is obtained. This adjustment should bring the receiver back to normal operation. If not, the Trimmer on the right should be adjusted in the same manner. The two center trimmers should not be adjusted except in rare cases, and extreme care should be taken when adjusting these Trimmers so that the selector Pointer will not be thrown off adjustment and read incorrectly.

Condenser Adjustments:
If the selector pointer will cover only 1500 to 600 Kilocycles on the selector strip, the two-fingered washer has become bent so that the stop washer will slide over it. To correct this, remove the selector shaft assembly and invert the flat, two-fingered washer.

If the Photo-switch will not trip, set the selector pointer at 1460 Kilocycles, loosen the set screws holding the switch lever and turn the switch lever until it just engages the switch. Tighten the set screws in this position.

Selector Strip Adjustment—Mechanical:
If the selector pointer appears to be off mechanically, i. e., if a station close to 700 Kilocycles is off 1/4 inch and a station close to 1400 Kilocycles is also off the same amount, the adjustment of the selector strip to log one station would bring them all into line.

To make such an adjustment, tighten all set screws, then tune in a station of known frequency. Reduce the volume by means of the volume control so that the selector can be set on the exact peak of the incoming wave. Loosen the screws holding the selector strip and shift the strip until it indicates properly the frequency of incoming signal.

If the selector strip cannot be shifted far enough, loosen the set screws by which the selector windshield is attached to the selector shaft and shift the pointer to its approximate position before shifting the selector strip.

Selector Adjustment—Electrical:

The adjustment of the selector electrically, is known as "logging". If it becomes necessary to change the set, tune in a station between 550 and 700 Kilocycles, preferably as close to 550 as possible, which is known to be broadcasting exactly on its assigned wave length. Set the selector pointer to log this station accurately as described in the preceding paragraph.

Then set the pointer on the exact frequency of a station known to be operating at that time between 1350 and 1500 kilocycles. Adjust the volume control until the station is just audible, without moving the pointer, adjust the left trimmer condenser (viewed from the front of the chassis) until maximum volume is obtained. Repeat the operation on the remaining three trimmers, one at a time, going from left to right until the station is peaked exactly on the correct reading.

Now try the station which was used to set the low frequency point and if it logs properly, all other stations will be in line. If the station does not log properly, repeat the above operation.

Hum:

If the No. 245 Tubes are unmatched, or if one or the other is defective, a hum will result which is very similar to what is known as 60 cycle hum. This can be eliminated by replacing one or both of the No. 245 Tubes.

It is to be understood that the No. 245 Tubes may not necessarily be defective. They may operate satisfactorily in another set, but may be merely unmatched with respect to each other.

The No. 227 Detector Tube will sometimes cause a similar trouble, except that the No. 227 Tube causes more of a buzz than a hum. If this buzz or hum cannot be eliminated by switching the 227 Tubes, the defective Tube should be replaced.

Volume Control:

Many complaints of unsatisfactory volume control action are not caused by defective volume controls, but in reality the faulty action is due to variation in the cut-off point of the No. 224 screen grid tubes. It is necessary to have, in the first R. F. stage at least, one tube which has a low cut-off point.

If the complaint is not due to a volume control which is actually defective, it usually can be eliminated by switching the No. 224 tubes from one socket to another until the proper arrangement is obtained.

In chassis with serial numbers between 29100A and 62100A (also 1700B and 1964B) a 7000 Ohm Resistor (Black and Blue) is connected between the cathodes of the screen grid tubes and ground, in parallel with one side of the volume control. When near a powerful local broadcasting station, the volume control, because of this resistor, may not cut the volume down low enough. This can be improved by removing the resistor mentioned. This is resistor No. R-21 shown in the wiring diagram.

Pos. Test Point	Neg. Test Point	Correct Reading
Center Terminal Condenser Can	Condenser Can Center Terminal	Hand Should Jump and Return Hand Should Rise Slowly, Almost to Full Scale

If both readings are the same, the condenser is defective and should be replaced. When in doubt try replacing the condenser.

COMBINATION MODELS No. 150 & 160.

MODEL 150,160,
Pick Up-Trans.
Service Notes.

GENERAL MOTORS RADIO CORP.

PART 1. THE ELECTRIC PICK-UP & TRANSFORMER

Description:

The electric pick-up provides an electrical means for sound reproduction. The pick-up is composed of three major parts:

1. A permanent magnet.
2. A small generating coil.
3. A vibrating armature which is caused to vibrate by the phonograph needle.

The generating coil is located in the center of the field of the permanent magnet which causes a constant flow of magnetic lines of force through the coil. In order to generate current in the coil, it is necessary to vary the strength of the magnetic field. This is accomplished by placing a vibrating armature in the center of the coil with a needle inserted in the needle holder.

The needle rides in the grooves on the record and as it vibrates back and forth it also causes the armature to vibrate. By the vibration of the armature in the magnetic field, the field strength is varied accordingly and a pulsating current of electricity is generated in the coil. The pulsations of this current correspond to the sound waves of the music, but they are too weak to be audible in the speaker.

The generating coil is connected, through a volume control, to the radio wiring and the electrical pulsations are amplified many times by means of the radio amplifying tubes.

When the pulsations of current generated in the generating coil have passed through the amplifying tubes, they are carried to the speaker unit where they set the diaphragm in motion which generates audible sound waves in the air.

- Pick up Transformer - Part No. 1,200,877
- Cord Assembly - Part No. 1,200,866
- Choke Coil - Part No. 1,200,869
- Condenser - Part No. 1,200,418

(Cord Assembly Part No. 12,001,184 used on Models 160-A and B -)

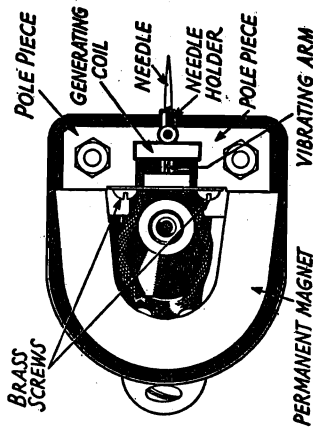

Figure 1

PART 1. THE ELECTRIC PICK-UP & TRANSFORMER (Continued)

in the center of the space between the two pole pieces.

If the vibrating armature is off center, loosen the two brass round head screws which hold the small brass plate in position on the pole pieces. Center the armature between the pole pieces and tighten the brass screws securely.

Testing for Open Coil or Wiring:

If there is no click at all, when tapping the needle, put the pick-up in place on the record and allow the record to rotate. Place the terminals of a set of ear phones on the two connections of the volume control to which leads from the pick-up connect. Reproduction of the record should be heard faintly.

Provided no sound is heard, remove the pick-up leads from the volume control and check for open circuit in those leads and the pick-up. (Note: Inspect the contacts on the pick-up end of the leads, to insure good contact in the socket on the pick-up.)

Repair Instructions:

Pick-ups that cannot be adjusted properly or that have open coils, should be replaced with new ones and the old ones returned to the nearest service station for repair.

Next Step if Pick-Up is O. K.:

If reproduction of the record can be heard faintly through the ear phones, check the volume control or the connections between the pick-up and the radio unit for the trouble.

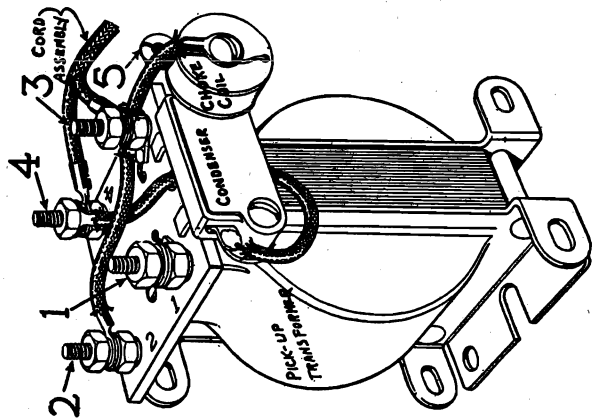

Figure 3

Make the following tests with an open test meter. (See Figure 3 for contact numbers.)

From Contact Number	To Contact Number	Proper Reading	Incorrect Reading Caused by
1	2	Full Scale	Open Winding
3	4	3/4 Scale	Open Winding
3	5	Full Scale	Open Choke
Cond. Lead from No. 4	5	*Hand should Jump and Return to Zero	Shorted or Open Condenser

*The Condenser Lead must be disconnected from No. 4.

Testing Pick-Up Transformer:

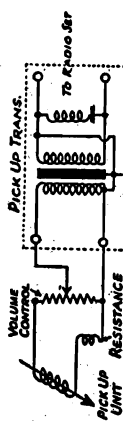

Figure No. 2 - Pick-Up Wiring Diagram

GENERAL MOTORS RADIO CORP.

MODEL 150, 160
Disc Motor
Service Notes

COMBINATION MODELS No. 150 & 160

PART 2. INDUCTION DISC MOTOR

Description:

The motor consists of an induction disc of aluminum arranged to revolve between the poles of two sets of field magnets. The coils of the field magnets, commonly called field coils, receive current from the house lighting circuit and are the only parts electrically connected to that circuit.

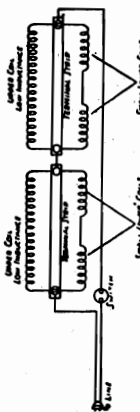

Figure 4—Wiring Diagram of Induction Disc Motor

The main shaft of the motor operates in a vertical position, is supported at the bottom by a single ball bearing, carries the induction disc and turntable, and drives the governor shaft through a set of gears. The speed of the shaft is controlled by a mechanical fly ball governor. The induction disc motor has no commutator, slip rings, or other moving electrical contacts, and this, with the natural slow speed, makes it very well suited for the service for which it is used.

Servicing:

Any servicing which the motor may require is in general, of a minor nature, and in most cases, adjustments will be mechanical rather than electrical. Two of the most common causes of motor failure are incorrect power voltage and lack of lubrication.

Power Voltage Variation:

High voltage will cause the motor coils to heat excessively and thus destroy the insulation and dry the lubrication.

Low voltage will cause a lack of power and unstable operation. When servicing the induction disc motor, always check the power line voltage at the socket to which the motor is connected and, if possible, while the motor is running. This voltage should be between 105 and 120 volts A. C.

Lubrication:

It is important that the motor be lubricated at least once every six months with the proper

lubricants. A motor lubricating chart is shown on the under side of the motor board.

A light grease should be used on the teeth of the drive gear and spiral. The governor bearings, governor friction sleeve and the upper and lower turntable spindle bearings should be lubricated with oil. For lubricating the governor friction leather use Neat's Foot Oil.

Motor Does Not Operate:

If the motor fails to start, first be sure that it is not binding in any place and that the turntable turns freely.

If it turns freely, check the wiring for open circuits with an open test meter.

With the switch closed, test across the contacts of the power plug. A full scale reading should be obtained. If not, this will indicate that the switch is defective or some part of the wiring is broken.

A visual inspection of the switch will show whether or not the trouble is in the switch. For information regarding the adjustments of the switch, see page 7.

If the switch is making good contact, check all wiring carefully for broken wires or loose connections.

If a full scale reading of the meter is obtained when testing across the light socket plug points, check the field coils. To determine which coil is defective, if any, it is necessary to test each coil separately.

Continuity Tests:

To do this, remove all connections from the two terminal strips, one located at each end of the motor. Refer to Figure 5 and take a reading across each coil with an open test meter as follows:

No. to No.	Correct Reading	Insistent Reading Caused by
1A—1B	Full Scale	Open Upper Coil
2A—2B	Full Scale	Open Lower Coil
1C—1D	Full Scale	Open Upper Coil
2C—2D	Full Scale	Open Lower Coil
B—C	Full Scale	Open Wiring

When replacing coils it is necessary to replace both the upper and lower coils as a unit. The

PART 2. INDUCTION DISC MOTOR (Continued)

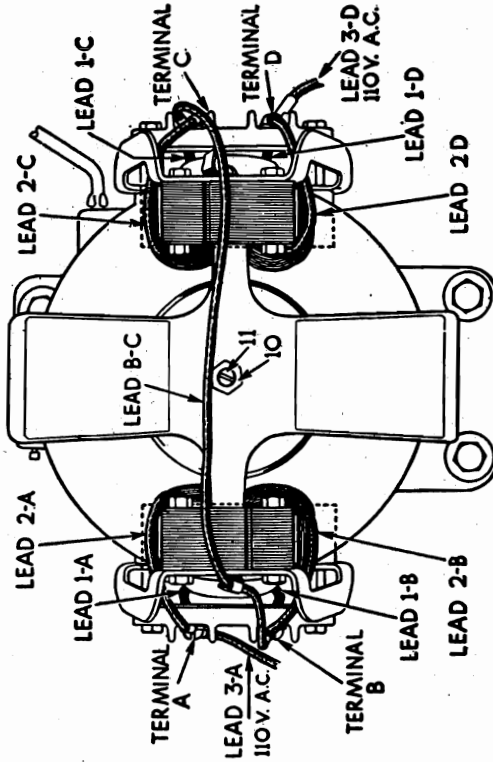

Figure 5

core and coil assembly may be taken off by removing the three screws holding the coils to the frame and top plate.

When the coils are replaced, be sure that the wire terminals marked with the same letter are placed together. That is, 1A, 2A and 3A must be attached to the terminal strip at the point "A", etc. See Figure 5.

Failure to Maintain Constant Speed:

There are four points to be checked if the motor fails to maintain constant speed.

Hardened or Gummed Lubrication. Examine the moving parts. If necessary, remove them and wash with kerosene. Replace the parts and lubricate them.

Slipping of Motor on Motor Board. In some cases a slight shifting of the motor on the motor board during shipment will cause binding. Loosen the three motor screws, and retighten, alternately, while the motor is running until the binding has been eliminated and the motor runs steadily.

Weak Coils. If the lubrication and mounting of the motor have been examined as described above, and the condition still exists, replace one

or both of the motor coils as described under subject "Motor Does Not Operate."

Mechanical Causes. All the points mentioned in subject entitled "Reducing Mechanical Noise" will have a certain effect upon the regulation of speed and should be taken into account even though there is no actual mechanical noise present.

Reducing Hum:

There are a number of causes for hum in the induction disc motor, but in most cases any existing hum can be eliminated by proper adjustment.

Loose Coil Winding on Iron Core. The condition can be corrected by forcing a small wooden wedge between the outside of the coil and the core. It may be necessary to wedge both the upper and lower sections of each coil.

Coil Loose on Top Plate. The three screws holding the coil on the top plate should be tightened securely.

Loose Laminations of Iron Core. The bolts clamping the iron laminations together should be tightened securely. In some cases, however, it may be found that the hum can be minimized by adjusting the tension of these bolts.

MODEL 150,160
Disc Motor
Service Notes

GENERAL MOTORS RADIO CORP.

COMBINATION MODELS No. 150 & 160

PART 2. INDUCTION DISC MOTOR (Continued)

Motor Not Fastened Securely to Motor Board. Make certain that the nuts holding the motor to the motor board are fastened securely and with equal tension and that the felt washers between the motor and the motor board are not injured.

Motor Not Properly Secured to Cabinet. In many cases motor hum can be eliminated or minimized by adjusting the four screws which hold the motor board to the cabinet. Placing a piece of felt between the motor board and the motor board rail will often help to eliminate hum.

Reducing Mechanical Noise: There are several features which may cause motor noise other than a hum.

Governor Springs. A noise or rattle may sometimes be caused by loose or broken governor springs. Tighten all the governor spring screws. If this does not stop the noise, loosen the screws on the disc end of the governor springs and allow the motor to run for a minute or so to allow the springs to assume their correct position. Stop the motor and retighten the screws. If any of the springs are broken or badly out of balance, they should be replaced. Removal of the governor can be accomplished by loosening the two governor bearing screws, one at each end of the shaft, and lifting the governor from the frame.

Governor Thrust Bearing The thrust bearing at the disc end of the governor may sometimes cause noise while the motor is running. Hold one finger over the end of the bearing and loosen the set screw which holds the bearing in position. Adjust the bearing to the most quiet running position, and retighten the set screw.

Governor Spindle. A bent governor spindle will cause binding in the gears and bearings as well as a noise. The bent spindle should be replaced with a new one.

Governor Driving Gear. Remove the turntable spindle as described above and examine the gear for wear. If the wear on the teeth is greater on one side than on the other, the turntable spindle is bent and should be replaced. The gear should also be replaced.

Turntable Spindles and Disc. A bent turntable spindle or a bent or improperly adjusted

PART 3. THE AUTOMATIC SWITCH & BRAKE

Description:

The automatic switch and brake consists of a system of cams and levers operating in such a manner that the movements caused by the eccentric groove at the end of the record trips the switch, forcing a friction leather against the turntable and, at the same time, cutting off the power to the motor.

Service:

The switch will ordinarily require no adjustment. In some cases, however, the upper spring shown in Figure 6 may become bent upward far enough to prevent the contacts from coming together when the hand lever is turned.

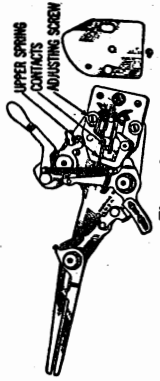

Figure 6

When such a condition is found, bend the upper spring down until the contact points make a firm contact when the hand lever is turned on. When replacing the switch on the brake plate, care should be observed in properly locating the switch on the plate, so that the switch will make and break contact when the hand lever is turned on and off. The two adjusting screws can be loosened and the switch moved in the slot until the correct position is located. When the hand lever is in the off position, the contact points should be at least 1/16 inch apart to prevent excessive sparking when the switch is turned off.

Adjustments:

The following adjustments will eliminate a majority of the troubles encountered:

1. **Switch Fails to Trip.** Bend the lug B (Figure 7) so that there will be less contact at point A.

Failure to trip may sometimes be caused by a loose trip arm. Make certain that all screws of this assembly are tight.

2. **Switch Trips Before the Completion of a Record.** Bend the lug back, so that there will be more contact at point A. (Figure 7.)

Warning: Do not bend the lug too far, as bending too often in opposite directions will snap off the lug

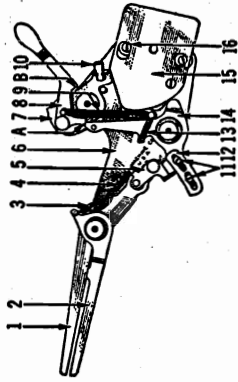

Figure 7

3. The two surfaces at the point A must be square. If they have become worn round, they should be squared with a fine file.

4. If the switch lever 1 swings with the eccentric groove, but the friction lever 2 fails to swing, or swings but slightly, the latch trip 5 is probably caught in a burr on one of the teeth of the latch plate 12. Rub the teeth of the latch plate with a piece of emery cloth, taking off any burrs that may be present.

5. If the latch trip does not engage with the latch plate properly when the tone arm is swung to the starting position, loosen the screw 11, adjust the plate 12 the required amount, and tighten the screws.

Note: The adjusting of the latch plate has nothing to do with the tripping of the latch.

6. If the brake does not stop the turntable soon enough the condition can be remedied by one of the following:
 - a. Examine the friction leather, making certain it is not worn down too far to make proper contact with the inside rim of the turntable.

- b. Increase the tension of the spring 9 (Figure 7) by cutting off one or more of the coils and then replacing the end of the spring over the lug.

7. If the latch 14 does not strike the lug A when the hand lever is pulled to the ON position:
 - a. Increase the tension of the spring 13 in the same manner as described above in "B" of 6.
 - b. Decrease the tension of the spring 4 by stretching the coils if necessary

MODEL 216, 217
219, 250
(S-1A, S-1B)
Voltage-Data

GENERAL MOTORS RADIO CORP.

MODEL 216, 217, 219, 250 SUPERHETERODYNE RECEIVERS.

ANTENNA AND GROUND CONNECTIONS

On Models 216, 217 and 219 a special antenna is installed in the cabinet and an antenna and ground terminal strip with three clips is located, on the bottom of the speaker baffle board.

If an outside antenna and ground are used, connect the antenna lead-in wire to the clip marked "A" and the ground wire to the clip marked "G". The jumper wire provided should connect clips marked "G" and "X".

If the local reception special antenna in the cabinet is used, connect the special antenna lead to the clip marked "A". The jumper should connect clips marked "G" and "X".

If the power line is to be used as an antenna, simply connect clips "A" and "X" by means of the jumper. If possible connect a ground wire to clip marked "G".

CONDENSERS					Voltage Divider			
NO.	CAPACITY	NO.	CAPACITY	LEAD COLOR				
C1	.00001 Mfd.	C7A	.25	Green				
C2	.0005 Mfd.	C7B	.25	Green				
C3	.002 Mfd.	C7C	.1	Brown				
C4	.01 Mfd.	C7D	.25	Terminal				
C5	.1-.1 Mfd.	C7E	.006	Red				
C6	.1 Mfd.	C7F	.25	Green				
		C7G	.03	Blue				
		C7H	.03	White-White				
	C8 4-4 Mfd. (Electrolytic)							
	C9 8 Mfd. (Electrolytic)							
Condensers C7A to C7H, inclusive, are included in the By-Pass Condenser Pack.								
RESISTORS						Pentode Bias		
NO.	BODY	END	SPOT	RESISTANCE	WATTS			
R1	Yellow	Green	Red	4,500				
R2	Red	Green	Orange	25,000				
R3	Yellow	Black	Orange	40,000				
R4	Brown	Black	Yellow	100,000				
R5	Green	Black	Yellow	500,000				
R6	In Metal Cover			400				
Type of Tube	Position of Tube	Fil. Volts	Plate Volts	Control Grid Volts	Screen Grid Volts	Cathode Volts*	Pentode Screen Volts	Normal Plate M.A.
224	1st Det.	2.1	225	2.0	85	7	--	1
235	1st I.F.	2.1	225	3.3	79	5	--	14
235	2nd I.F.	2.1	225	3.3	75	5	--	13
227	Oscillator	2.15	75	0	--	0	--	5
227	2nd Det.	2.15	125	15.0	--	15	--	1
247	A. F.	2.15	210	1.0	--	--	200	3.5
280	Rect.	4.5	300	--	--	--	--	25-25
Line Volts 110.				Volume Control on Full.				

GENERAL MOTORS RADIO CORP.

MODEL 251
(S-2A, S-2B)
Schematic

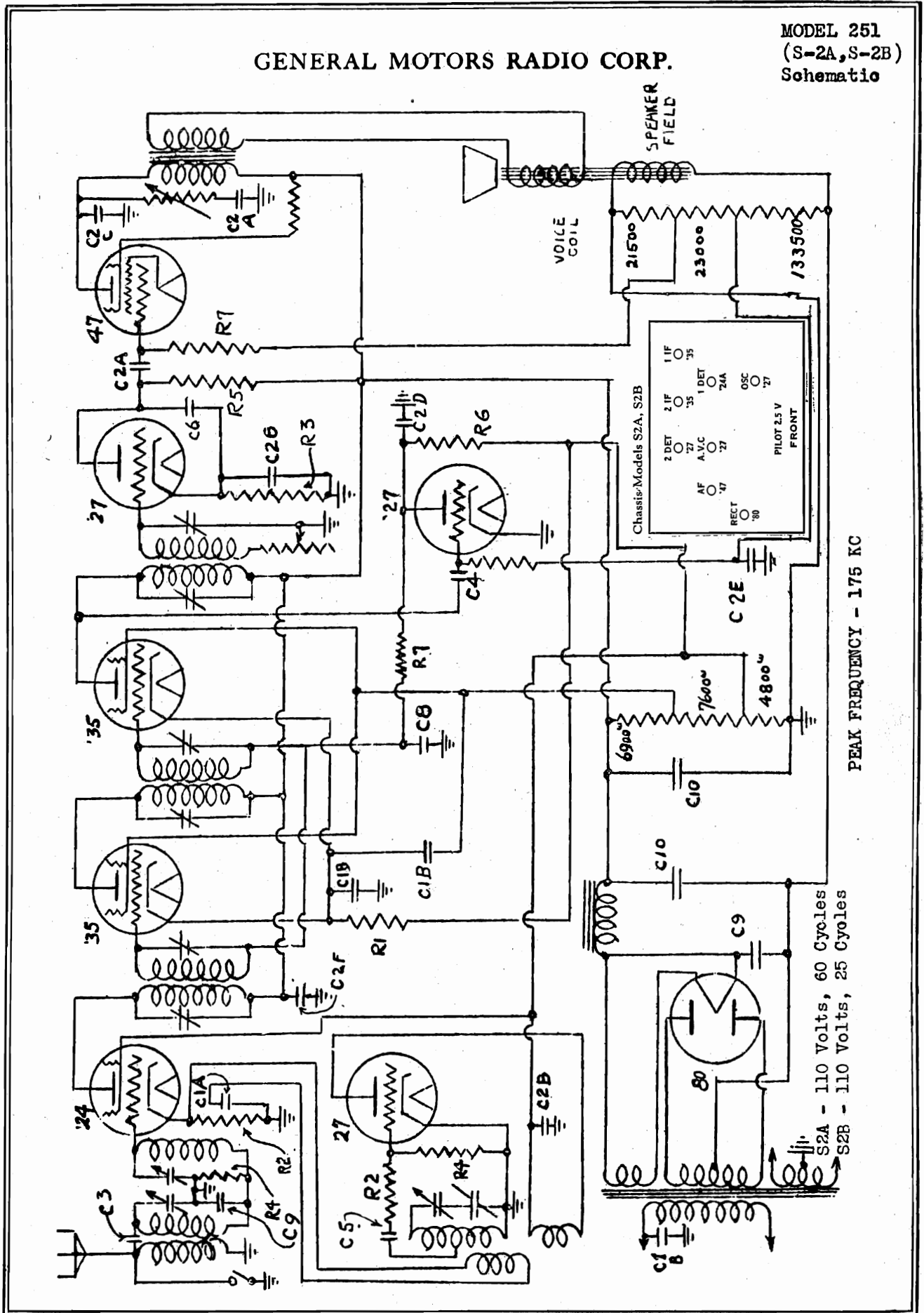

MODEL 251
(S-2A, S-2B)
Voltage-Data

GENERAL MOTORS RADIO CORP.

MODEL 251 SUPERHETERODYNE (CHASSIS MODELS S2A & S2B)

Type of Tube	Position of Tube	Fil. Volts	Plate Volts*	Control Grid Volts	Screen Grid Volts	Cathode Volts#	Pentode Screen Volts	Normal Plate MA	Rated Fil. Volts
224	1st Det.	2.1	255	1.9	77	6.0	--	1.0	2.20
235	1st I.F.	2.1	200	.3	100	95.0	--	1.6	2.20
235	2nd I.F.	2.1	200	.3	100	95.0	--	1.6	2.20
227	2nd Det.	2.15	145	.0	--	15.0	--	.5	2.25
227	Osc.	2.15	75	.0	--	0	--	7.0	2.25
227	A.V.C.	2.15	60	.0	--	0	--	.0	2.30
247	A.F.	2.15	235	1.0	--	--	215	30.0	2.30
280	Rect.	4.5	200	--	--	--	--	30-30	4.70

Line Volts 110

Volume on Full

* Use 600 Volt Scale.

Measured from Cathode to Heater.

Pentode Bias	Voltage Divider	No.	Capacity
		C1A	.1 Mfd. } By-Pass Cond.
		C1B	1.0 Mfd. } Pack No. 1
		C2A	.03 Mfd.
		C2B	.1 Mfd.
		C2C	.006 Mfd. } By-Pass Cond.
		C2D	.25 Mfd. } Pack No. 2
		C2E	1.0 Mfd.
		C2F	.25 Mfd.
		C2G	.1 Mfd.
		C3	.00001 Mfd.
		C4	.00025 Mfd.
		C5	.00075 Mfd.
		C6	.002 Mfd.
		C7	.01 Mfd.
		C8	1.0 Mfd.
		C9	4.0 Mfd. (Electrolyt.)
		C10	8.0 Mfd. (Electrolyt.)

Resistors

No.	Body	End	Spot	Resistance	Watts
R1	Orange	Black	Brown	300	
R2	Yellow	Green	Red	4,500	
R3	Red	Green	Orange	25,000	
R4	Yellow	Black	Orange	40,000	
R5	Brown	Black	Yellow	100,000	
R6	Red	Green	Yellow	250,000	
R7	Green	Black	Yellow	500,000	
R8	Red	Black	Green	2 Megohms	

The dial light bulb is a Mazda No. 41, rated at 2½ volts.

GENERAL MOTORS RADIO CORP.

MODEL 252, 253, 254,
255, 256, 257,
258
(S-3A, S-3B)
Schematic

Chassis Models S3A, S3B, S4A, S4B

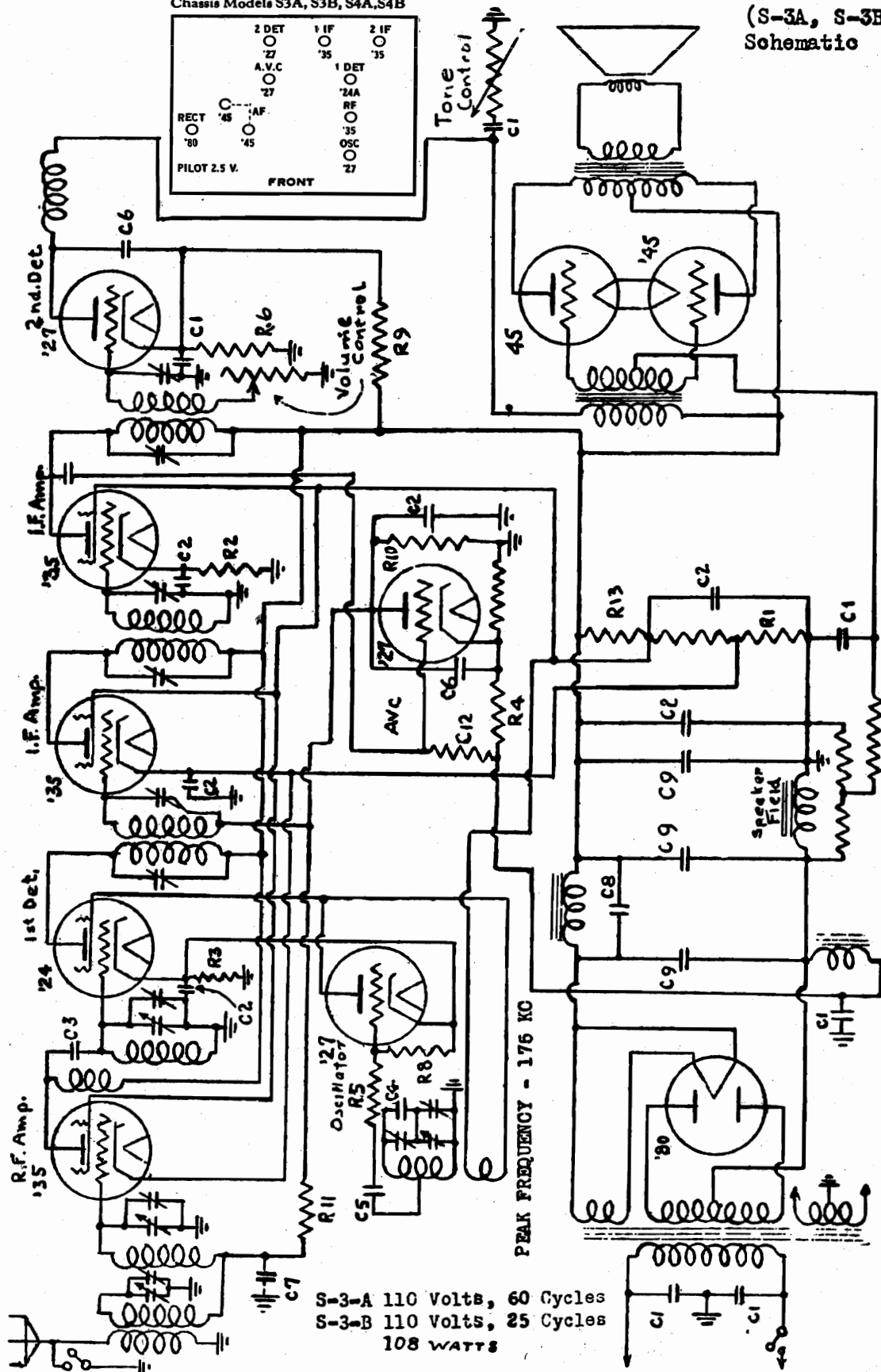
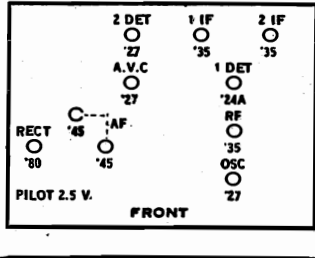

PEAK FREQUENCY - 176 KC

S-3-A 110 Volts, 60 Cycles
S-3-B 110 Volts, 25 Cycles
108 WATTS

MODEL 252,253,254,
255,256,257,
258

GENERAL MOTORS RADIO CORP.

(S-3A, S-3B)

Voltage-Data

MODELS 252, 253, 254, 255, 256, 257, 258 SUPERHET. RECEIVERS.
(CHASSIS MODELS S3A & S3B)

Type of Tube	Position of Tube	Fil. Volts	Plate Volts	Control Grid Volts	Screen Grid Volts	Cathode Volts	Normal Plate M.A.	Grid Change
227	Oscillator	2.1	65	.3	---	7	5	0
235	R. F.	2.1	230	.5	77	2.5	6	3.5
224	1st Det.	2.1	230	5.0	65	5	1	.3
235	1st I.F.	2.1	230	.5	77	3	5	3.5
235	2nd I.F.	2.1	230	5.0	60	10	8	3.5
237	2nd Det.	2.2	205	23.0	---	23	1	4.0
227	A.V.C.	2.2	25	2.5	---	30	0	0
245	A.F.	2.2	230	20.0	---	---	30	35
245	A.F.	2.2	230	20.0	---	---	30	35
280	Rectifier	4.5	330	---	---	---	30-30	---

Line Volts, 110

Volume Control on Full

CONDENSERS

No.	CAPACITY
C1	1.0 - 1.0 - .1 - .1 - .1 Mfd.
C2	.5 - .5 - .5 - .1 - .1 - .1 Mfd.
C3	5 Mmfd.
C4	.0007 Mfd.
C5	.00075 Mfd.
C6	.002 Mfd.
C7	.02 Mfd.
C8	.5 Mfd.
C9	8.0 Mfd. (Electrolytic)

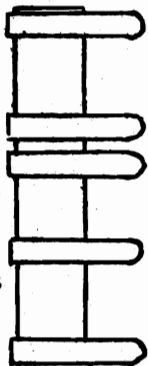

245 Bias Resistor

Black, Yellow Spot 100,000 Ohms

Black, Yellow Spot 100,000 Ohms

Brown, Yellow Spot 110,000 Ohms

RESISTORS

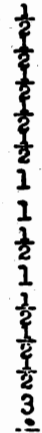
NO.	BODY	END	SPOT	RESISTANCE	WATTS
R1	Brown	Green	Brown	150	
R2	Lavender	Green	Brown	750	
R3		Solid Lavender		1250	
R4	Green	Black	Orange	50,000	
R5	Blue	Black	Red	6,000	
R6	Brown	Black	Orange	10,000	
R7	Brown	Gray	Orange	18,000	
R8	Yellow	Black	Orange	40,000	
R9	Brown	Brown	Yellow	110,000	
R10	Orange	Black	Yellow	300,000	
R11	Green	Black	Yellow	500,000	
R12	Red	Black	Green	2 Megohms	
R13		Solid Orange		14,550	

The dial light bulb is a Mazda No. 41, rated at 2½ volts.

MODEL 220
(S-10A, S-10B)
Schematic

GENERAL MOTORS RADIO CORP.

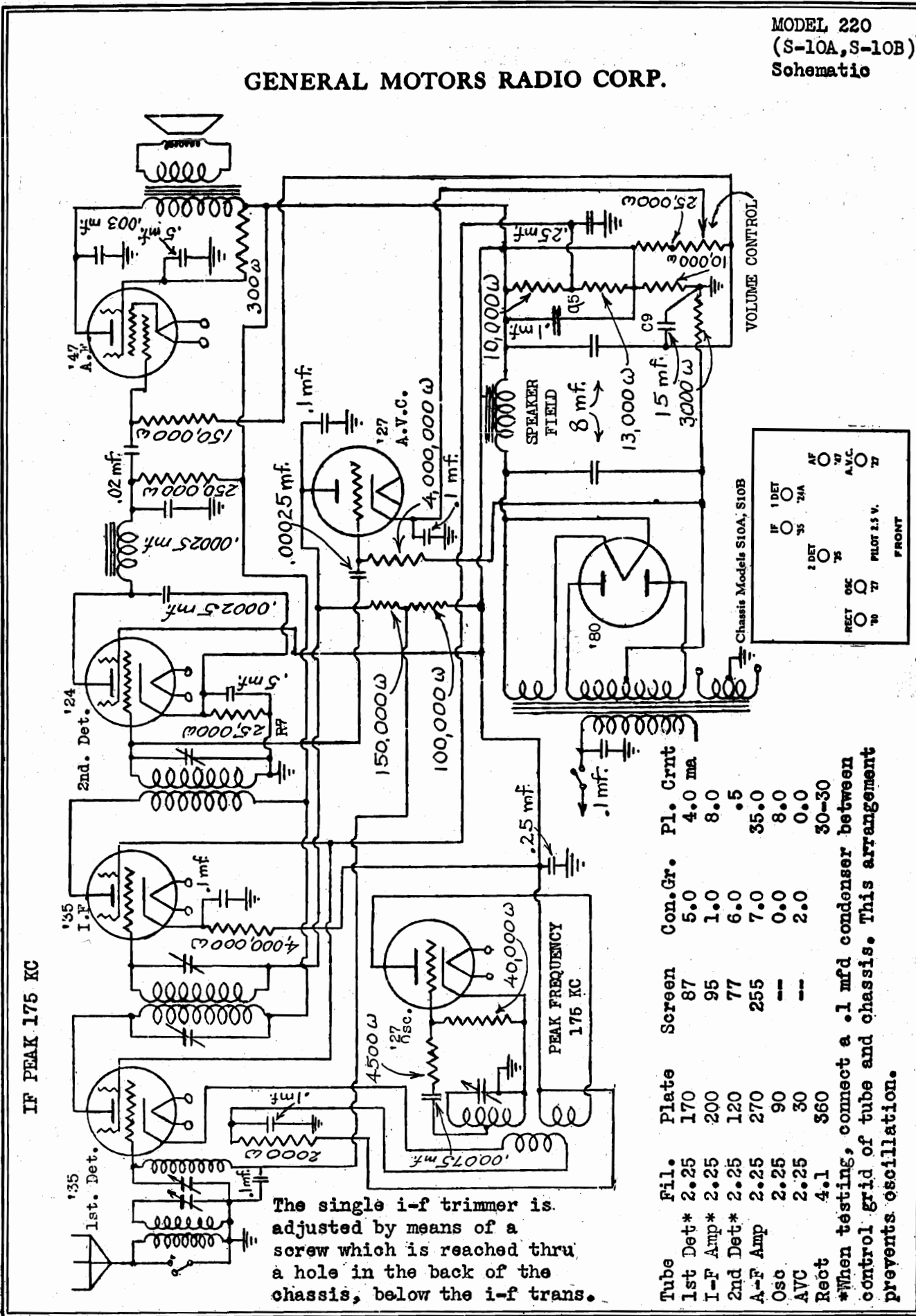

Tube	Fil.	Plate	Screen	Con. Gr.	Pl. Crnt
1st Det*	2.25	170	87	5.0	4.0 ma
I-F Amp*	2.25	200	95	1.0	8.0
2nd Det*	2.25	120	77	6.0	.5
A-F Amp	2.25	270	255	7.0	35.0
Osc	2.25	90	---	0.0	8.0
AVC	2.25	30	---	2.0	0.0
Rect	4.1	360	---	---	30-30

*When testing, connect a .1 mfd condenser between control grid of tube and chassis. This arrangement prevents oscillation.

The single i-f trimmer is adjusted by means of a screw which is reached thru a hole in the back of the chassis, below the i-f trans.

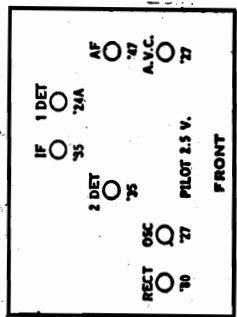

MODEL 220
(S-10A, S-10B)
Trimmer Notes

GENERAL MOTORS RADIO CORP.

PEAKING THE I.F. STAGES

CONNECTIONS

(1) Connect the test oscillator to the control grid of the first detector tube, with a fixed .002 Mfd. condenser connected in series between the test oscillator and the grid terminal of the tube. The grid cap and lead must be left in place on the tube. Connect the GND terminals of both the test oscillator and the receiver to a common ground.

NOTE: DO NOT CONNECT TO THE GRID OF ANY OTHER TUBE BECAUSE IT WILL CHANGE THE BIAS VOLTAGE OF THE SET.

If the test oscillator has a dummy antenna which cannot be disconnected, connect a 1 megohm resistor between the test oscillator output terminal and ground.

(2) Remove the 227 oscillator and the 227 A.V.C. tube and plug the dummy oscillator and A.V.C. tubes in their sockets.

TRACKING PROCEDURE

(1) Feed a signal of exactly 1400 K.C. into the chassis from the test oscillator.

(2) Screw all parallel trimmers down tight and then adjust the oscillator parallel trimmer to obtain a maximum output.

(3) Adjust the remaining parallel trimmer condensers to obtain maximum output.

NOTE: Models S10A or S10B chassis do not employ an oscillator series condenser. It is not necessary to make the tracking adjustment at 580 K.C.

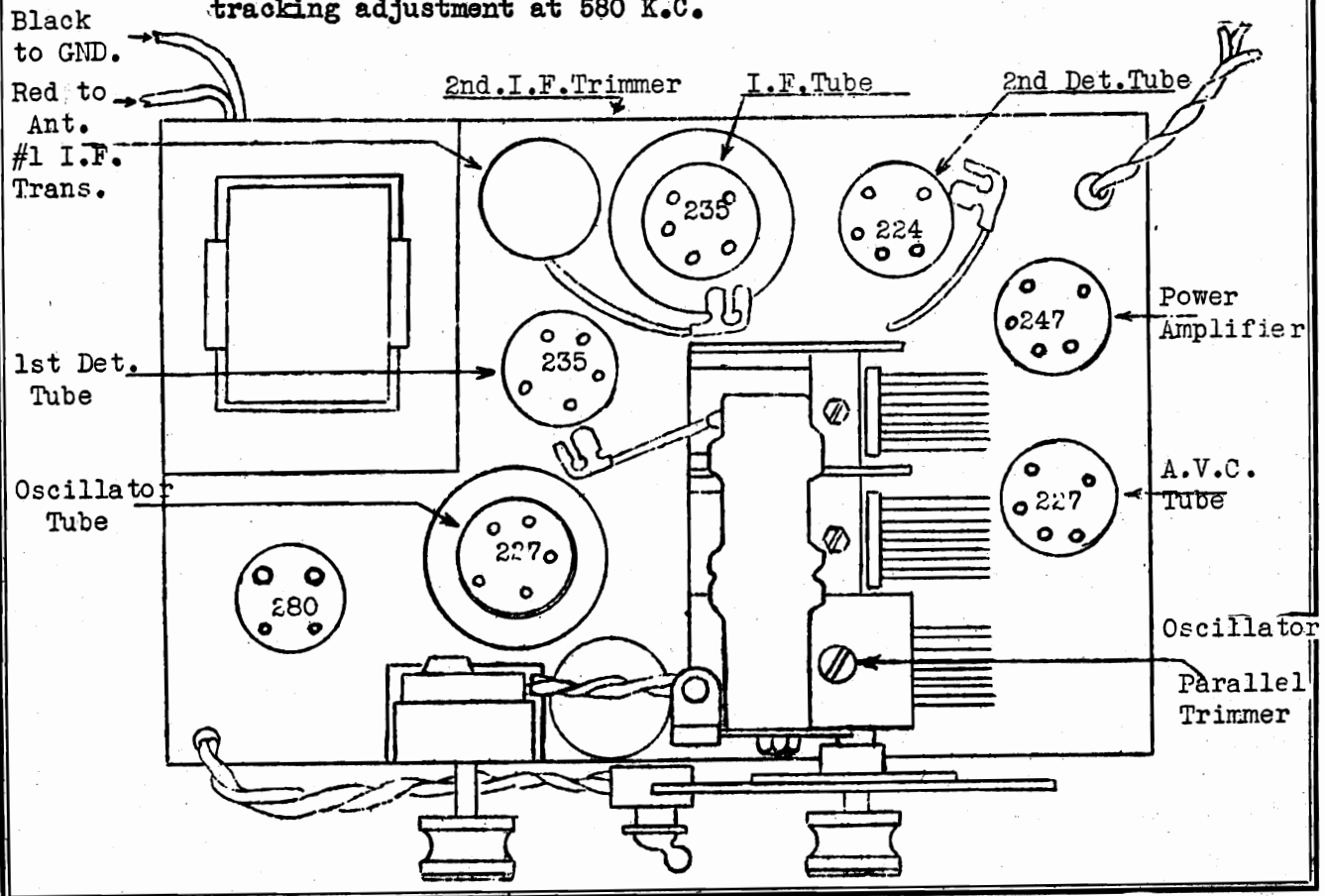

GRIGSBY GRUNOW CO.

MODEL 70-B
Chassis

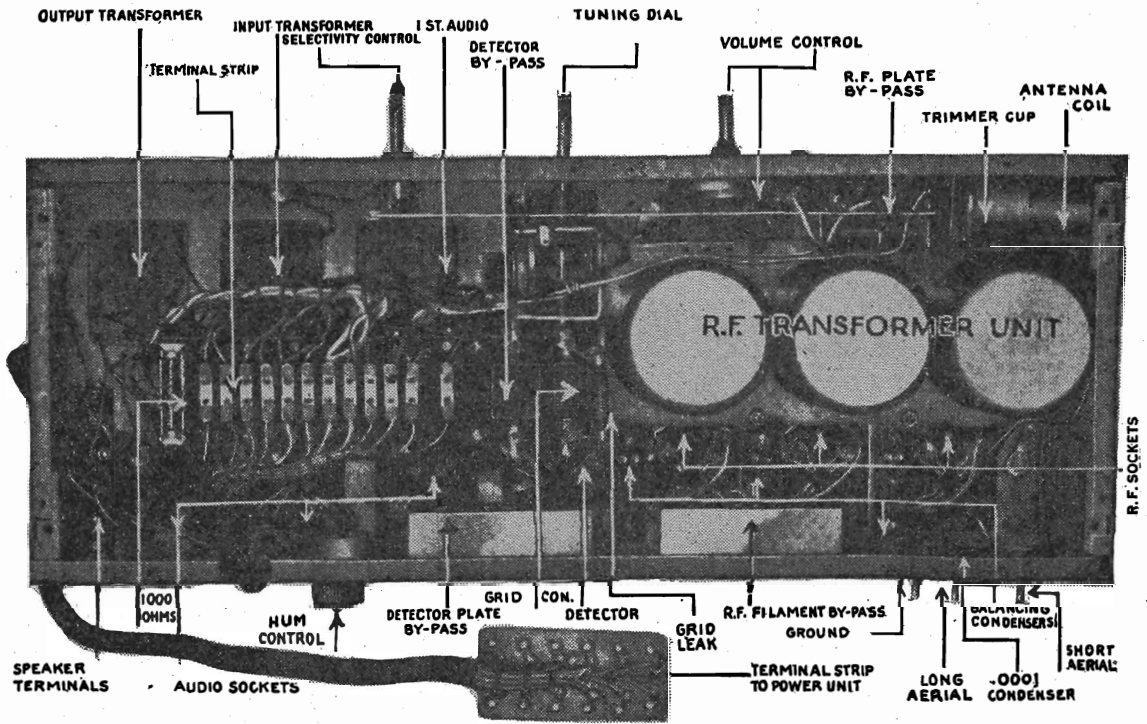

Model 70-B Chassis

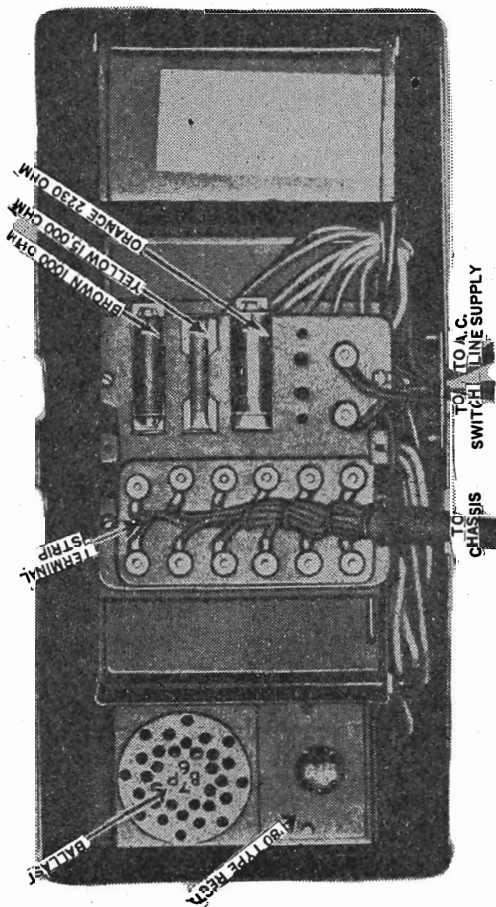

7-BP-6-7-BP-3 Power Unit

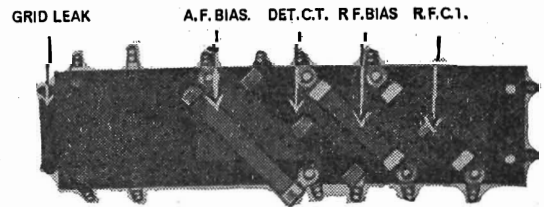

Bottom View of Terminal Board in 70-B Chassis, Showing Resistors Employed

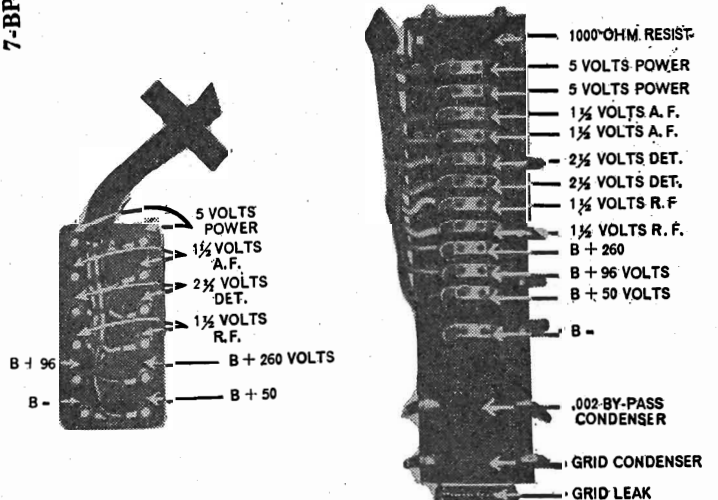

Cable for 70-B Chassis, Showing Resistors, Grid Condenser and Leak, and Voltages at Terminals.

**MODEL 180
Chassis**

GRIGSBY - GRUNOW CO.

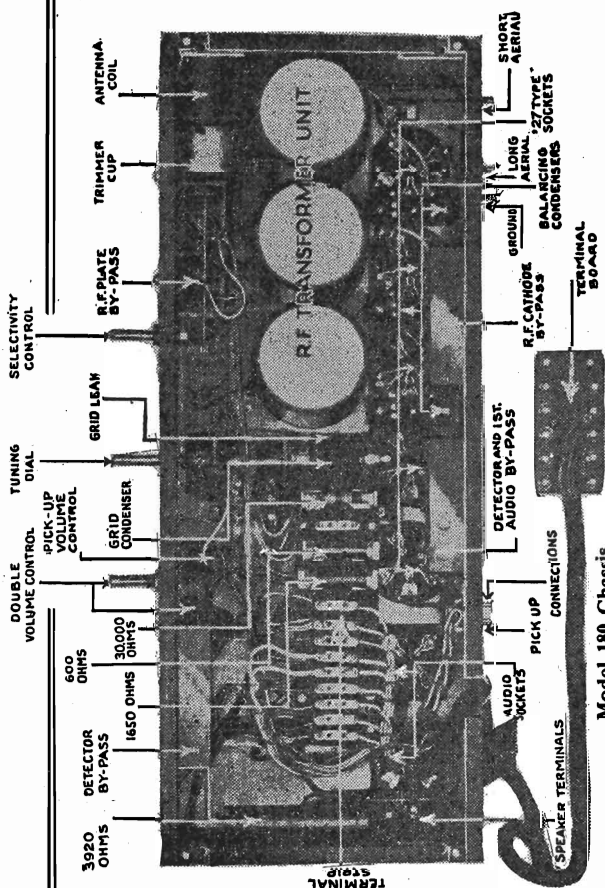

Model 180 Chassis

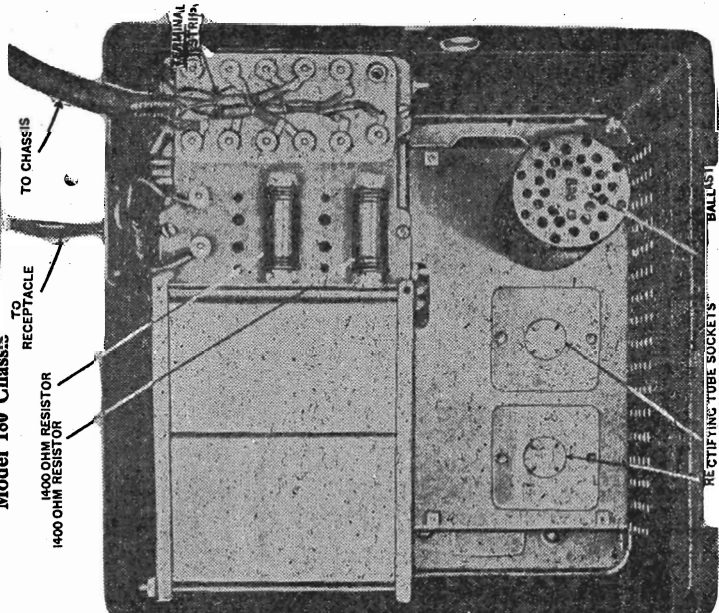

Top View of Model 8-P-6-8-P-3 Power Unit

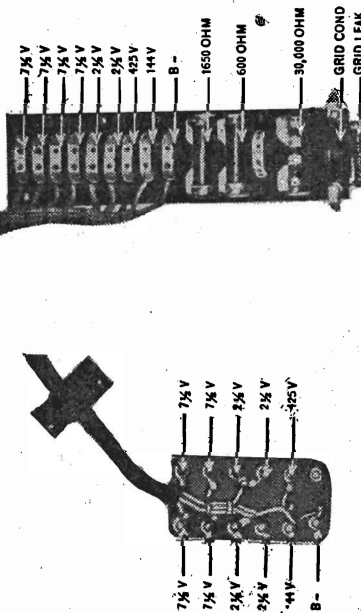

Power Cable and Terminal Board of Model 180 Chassis, Showing Resistors, Grid Leak and Condenser, and Voltages Supplied.

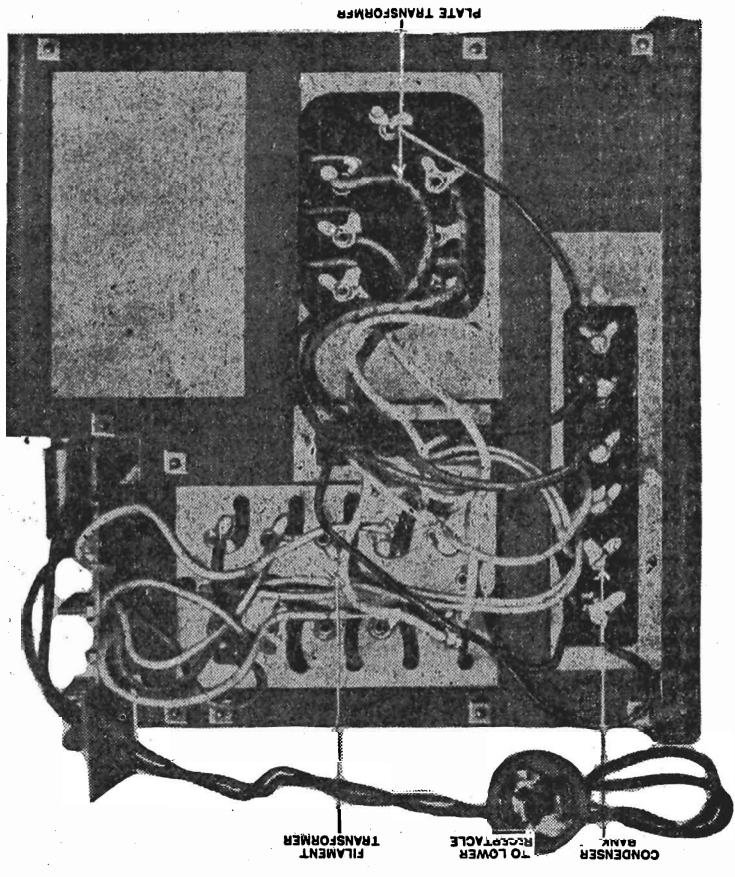

Side View of 8-P-6-8-P-3 Power Unit, Showing Internal Wiring

GRIGSBY - GRUNOW CO.

MODEL 90
MODEL 100
Chassis

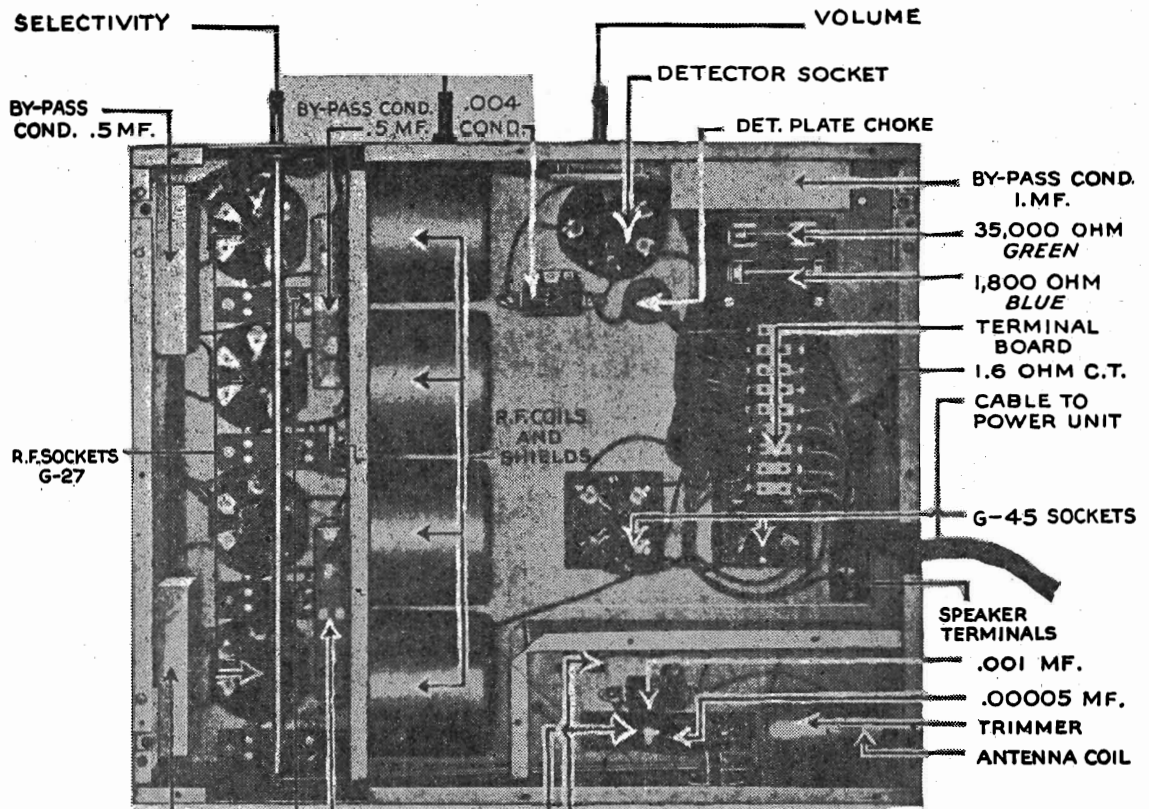

Position of Parts, and Wiring of Model 90 Receiver

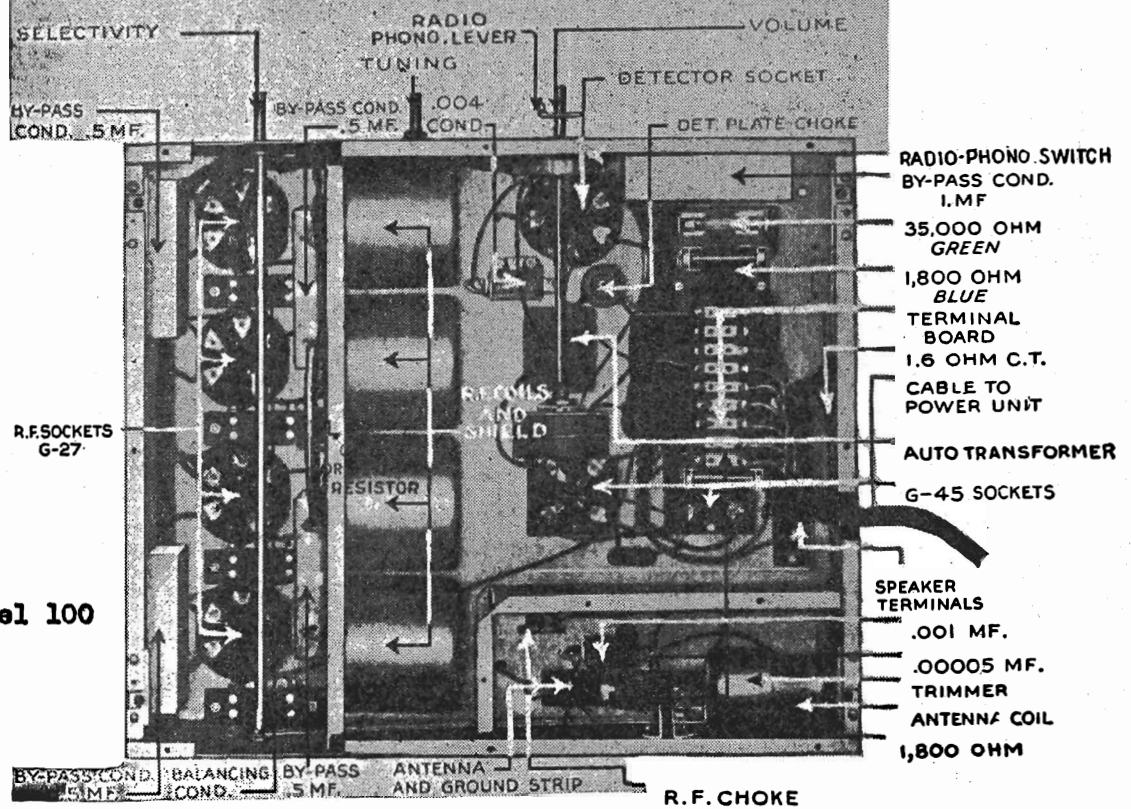

Model 100

MODEL 15
Schematic
Below Serial
65149

GRIGSBY - GRUNOW CO.

SCHEMATIC DIAGRAM OF MAJESTIC SCREEN GRID SUPERHETERODYNE RECEIVER
MODEL 15 (65149 TO INCLUSIVE) CHASSIS 115 AND 230 VOLTS, 25-50 AND 50-60 CYCLES
POWER REQD.—60 WATTS

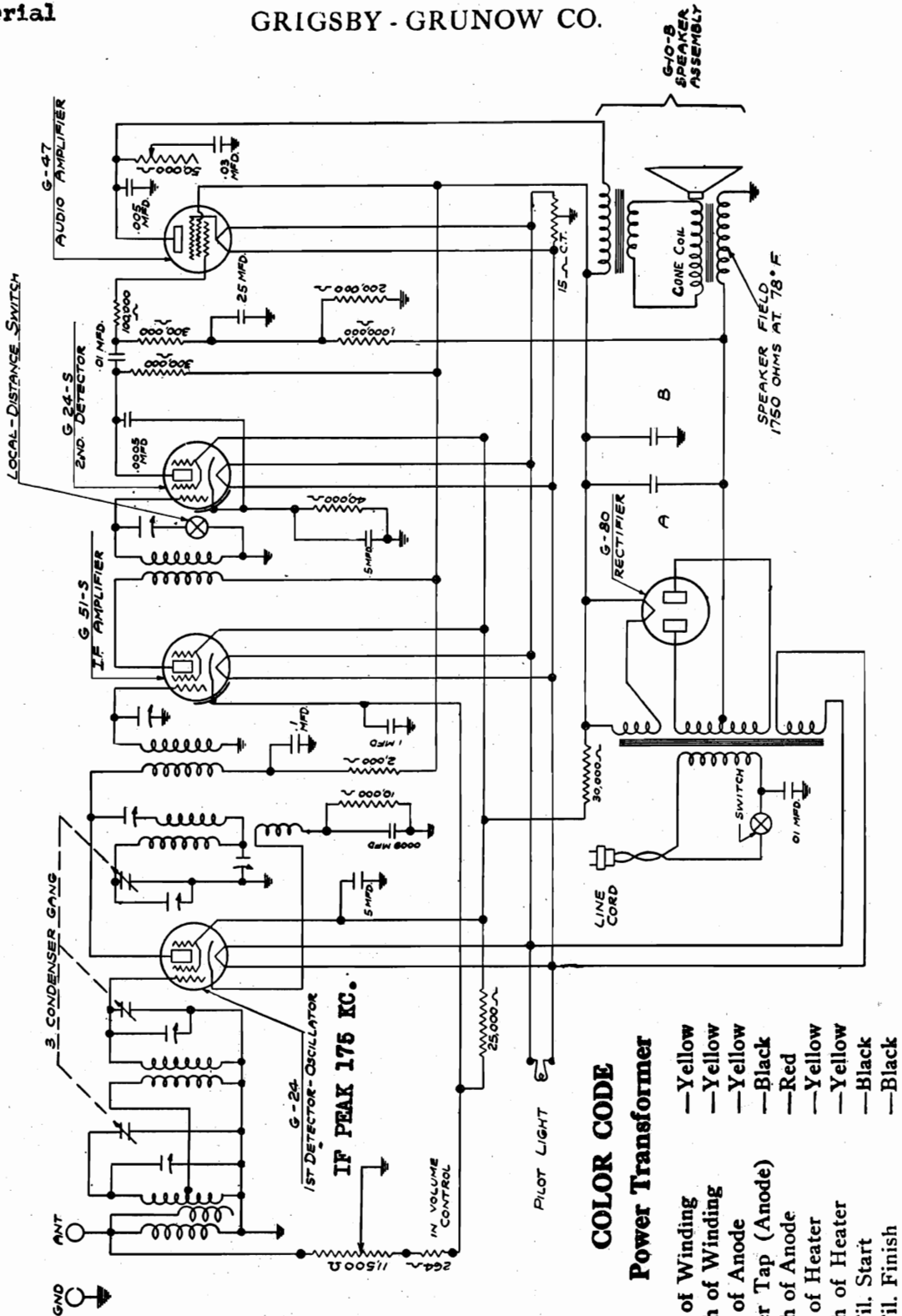

- COLOR CODE**
- Power Transformer**
- Yellow Start of Winding
 - Yellow Finish of Winding
 - Yellow Start of Anode
 - Black Center Tap (Anode)
 - Red Finish of Anode
 - Yellow Start of Heater
 - Black 280 Fil. Start
 - Black 280 Fil. Finish

MODEL 15 Chassis (up to 65, 149 Incl.) 115-230 V. 25-50 & 50-60 Cycles - 60 Watts.

Model 15 Chassis
Employed in Havenwood, Ellswood and Sherwood Models

GRIGSBY - GRUNOW CO.

MODEL 15
Chassis Views

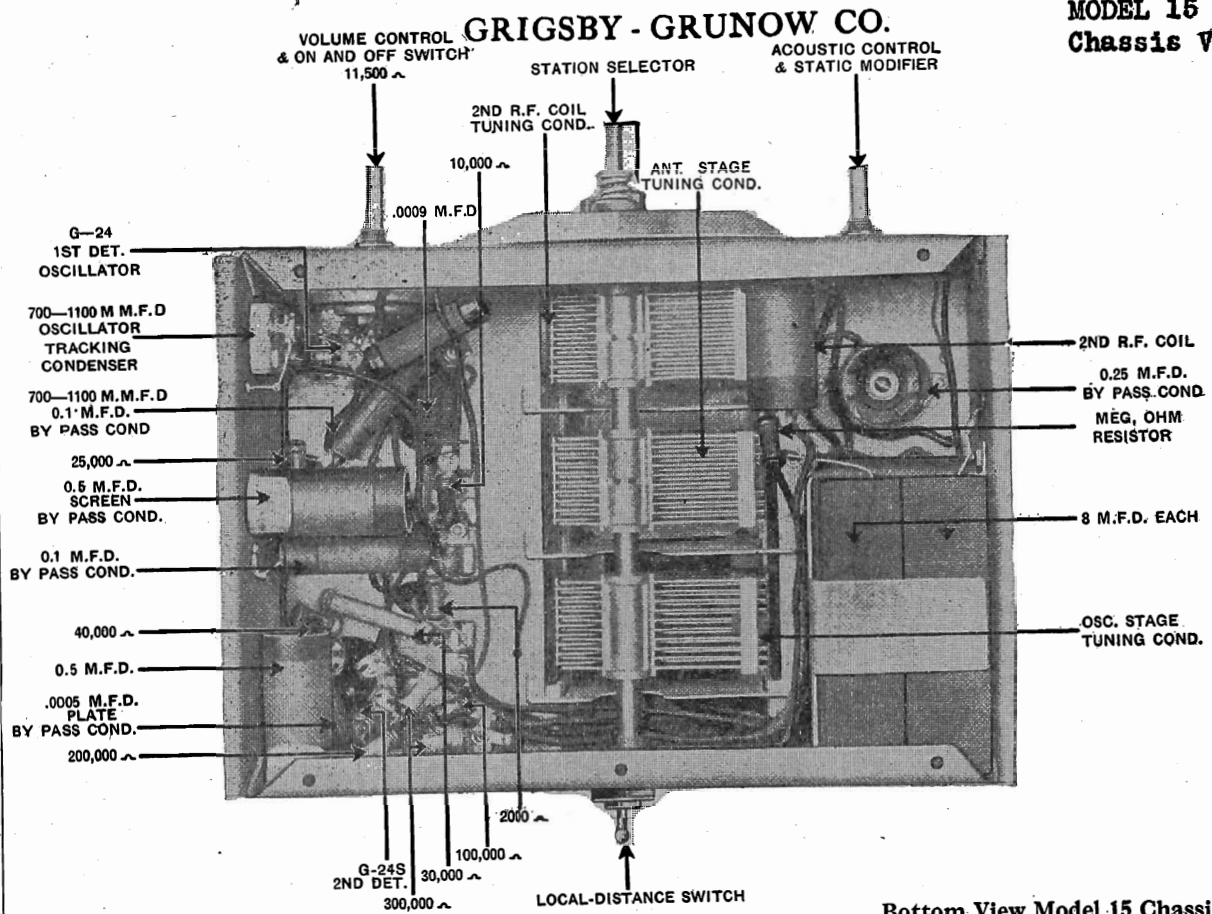

Bottom View Model 15 Chassis

Tube Purpose	Type	Fil. Volts A.C.	Plate Volts D.C.	Grid Volts D.C.	Cathode Volts D.C.	Plate Current M.A.	Screen Volts D.C.
I.F. Amplifier	G-51-S	2.5	250	3.0**	3.0**	7.0	90
2nd Detector	G-24-S	2.5	250	9	9	0.17	90
Power Amplifier	G-47	2.5	250	-16.5*	...	0.32	250
Rectifier	G-80	5 0	250	54	...

*This cannot be measured with the customary 1000 ohm per volt meter because of the high resistance between the grid and ground. If there is any doubt about the pentode bias, check the 100,000 ohm, 1 megohm, 200,000 and 300,000 ohm resistors and .25 M.F.D. Condenser in this circuit and be sure the speaker field voltage is correct, 112 volts. Also measure the pentode plate and screen voltages and if they are 250 volts, the plate current should be 32 M.A.

**This should rise to 42 when the volume control is turned to minimum.

Table of Voltages to Ground

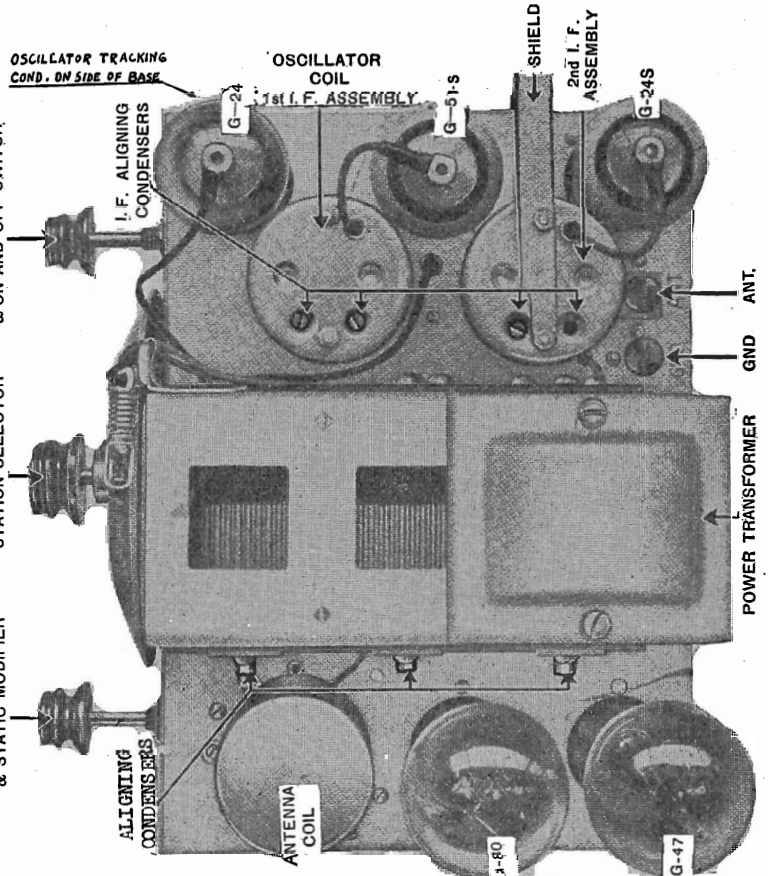

Model 15 Chassis

Top View

MODEL 15,15-B
Schematic
Above Serial
65150

GRIGSBY - GRUNOW CO.

SCHEMATIC DIAGRAM OF MAJESTIC SCREEN GRID SUPERHETERODYNE RECEIVER
MODEL 15 AND 15-B CHASSIS (SERIAL NO. 65,150 AND OVER) 15 AND 230 VOLTS, 25-50 AND 50-60 CYCLES.
POWER REQD. - 60 WATTS.

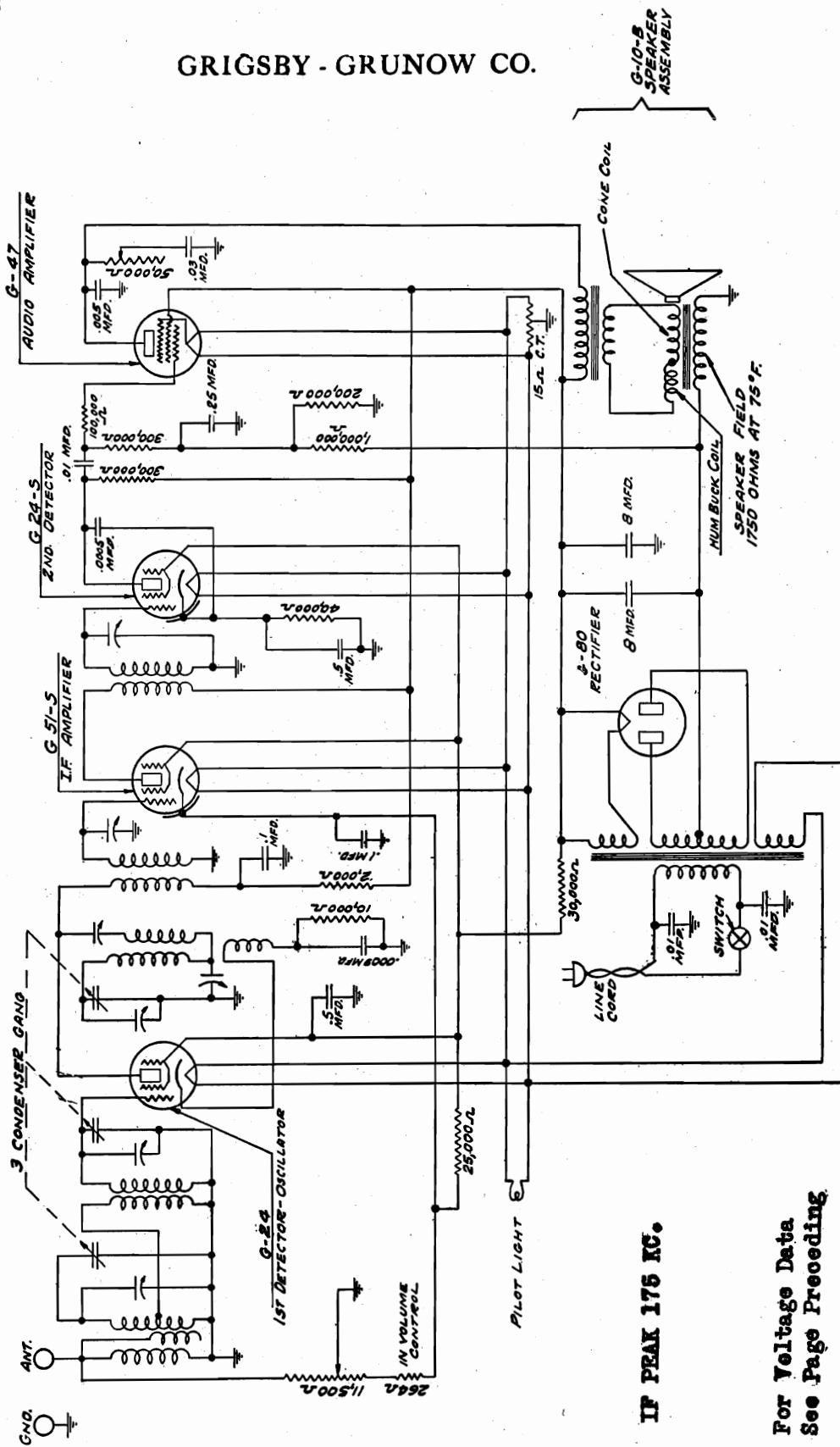

IF PEAK 175 KC.

For Voltage Data
See Page Preceding

Model 15B Chassis Employed in Fyfewood Model

MODEL 15-B
Chassis Views

GRIGSBY - GRUNOW CO.

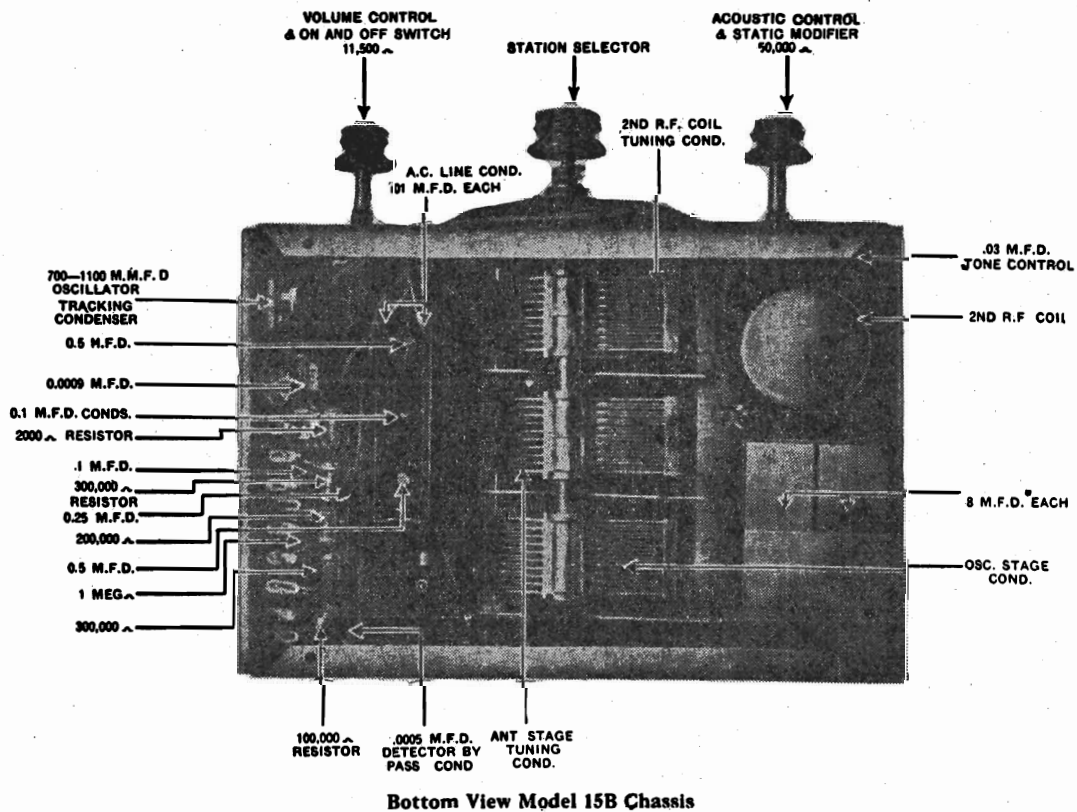
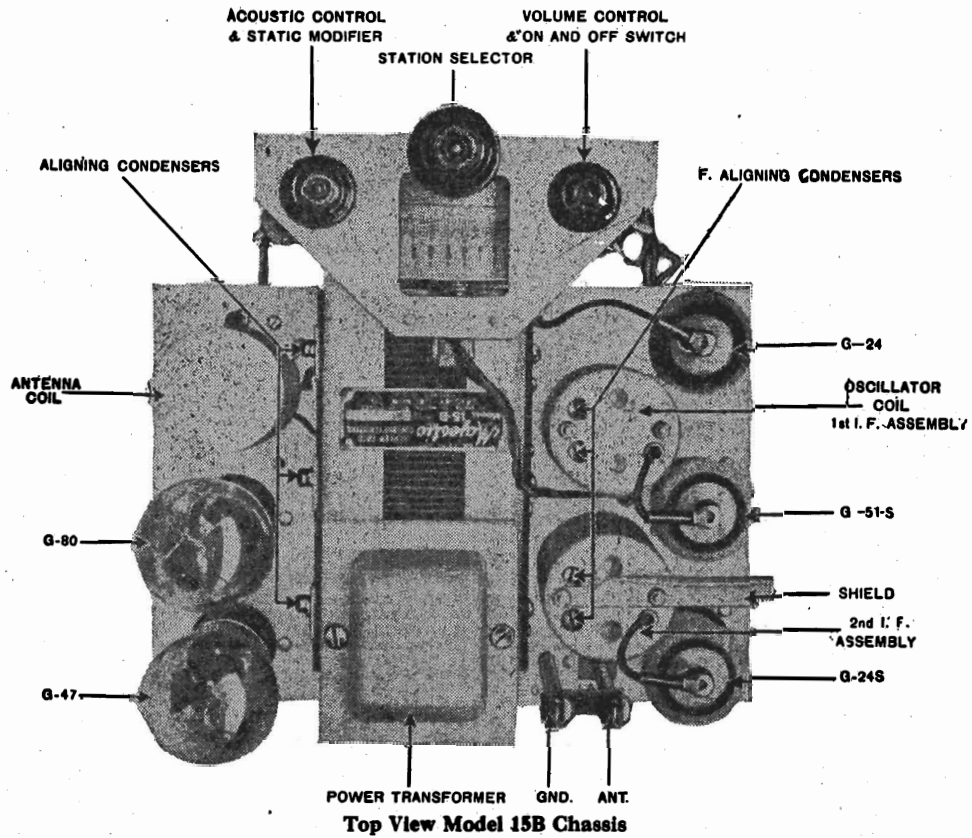

MODEL 25
Schematic

GRIGSBY - GRUNOW CO.

SCHEMATIC DIAGRAM OF MAJESTIC SCREEN GRID SUPERHETERODYNE RECEIVER
MODEL 25 CHASSIS—115 AND 230 VOLTS, 25-50 AND 50-60 CYCLES
POWER REQD.—120 WATTS

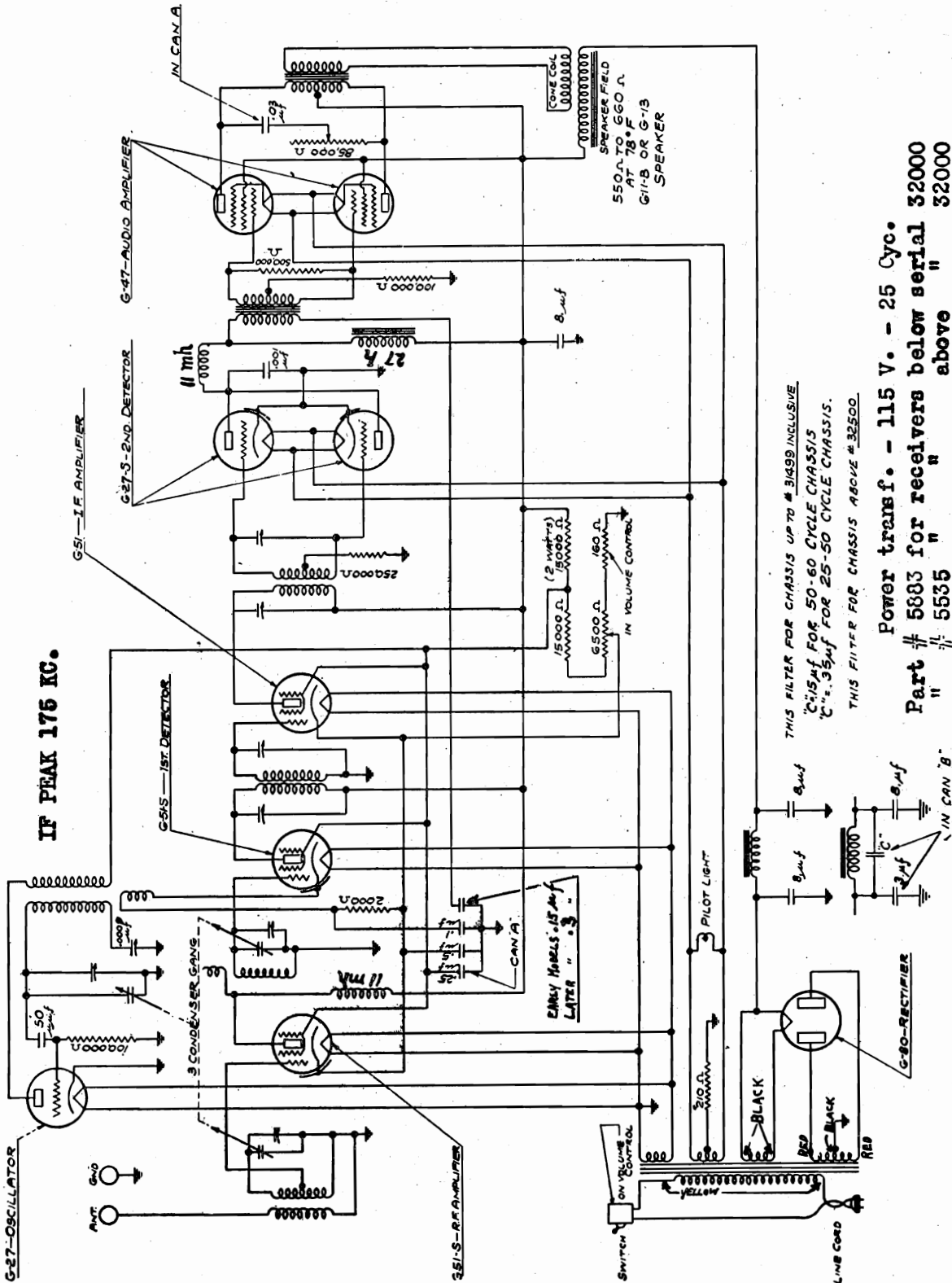

Model 25 Chassis
Employed in Brentwood, Cheltenham and Brucewood Models

GRIGSBY - GRUNOW CO.

MODEL 25
Chassis Views
Voltage

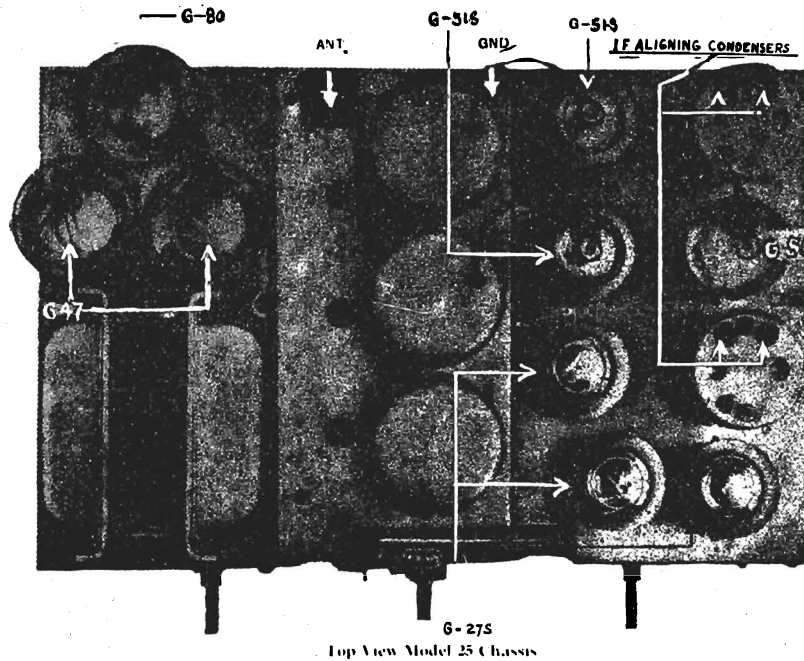
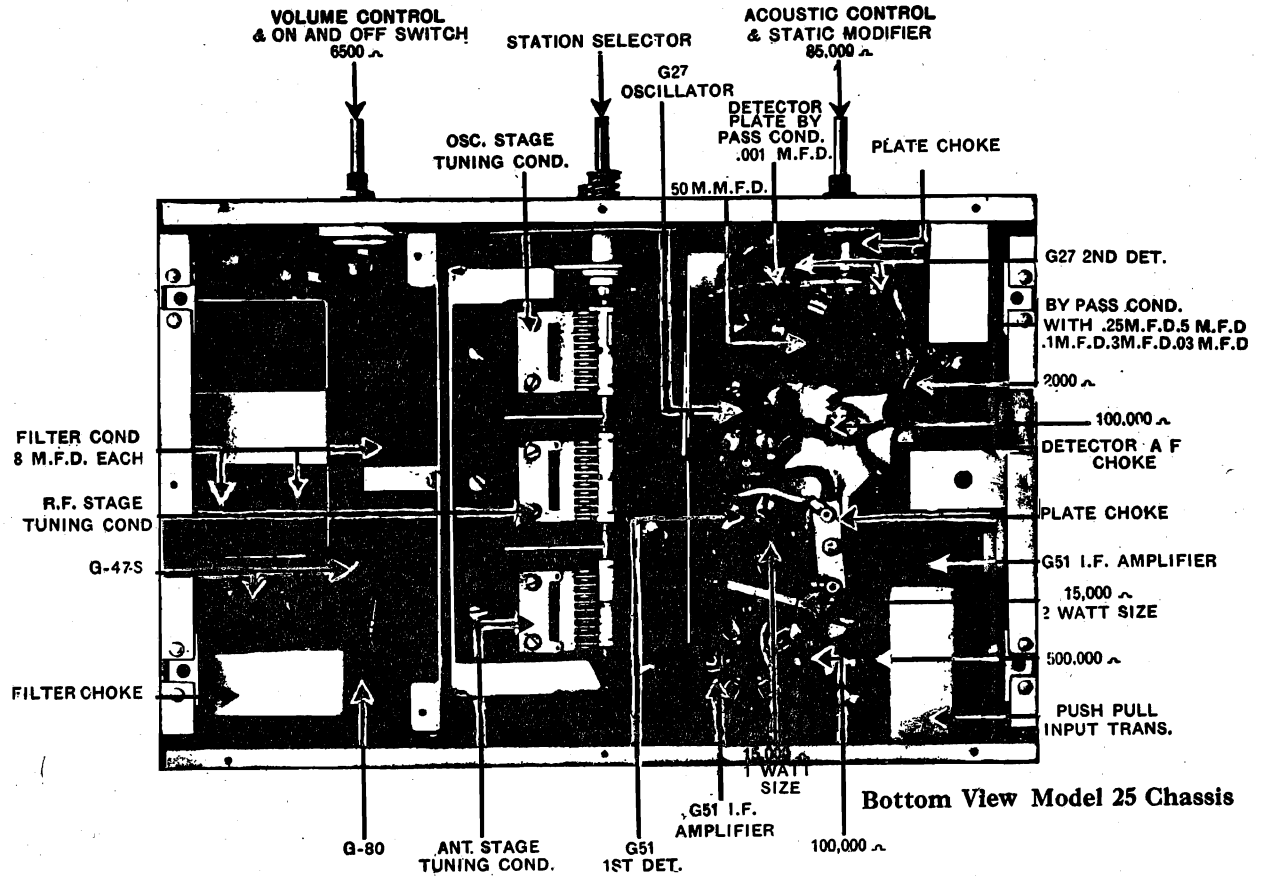

Tube Purpose	Type	Fill Volts A.C.	Plate Volts D.C.	File to Ground D.C.	Cathode Volts D.C.	Plate Current M.A. D.C.	Screen Volts
R.F. Amp	G-51's	2.5	260	—	3.5	5.0	90
1st Det	G-27's	2.5	260	—	8.0	1.0	90
Osc	G-27	2.5	90	—	—	3.5	—
I.F.	G-51's	2.5	260	—	3.5	5.5	90
2nd Det	G-27's	2.5	115	—	—	—	14
2nd Det	G-27's	2.5	115	—	—	—	14
Power Amp.	G-47	2.5	245	-16.5	—	32	260
Power Amp.	G-47	2.5	245	16.5	—	32	260
Rectifier	G-80	5	400	—	—	120 (Total)	—

Speaker Field 70 Volts
Volume Control—Maximum

Table of Voltages to Ground
Model 25

MODEL 25-B
251, 253, 254
Schematic

GRIGSBY - GRUNOW CO.

MAJESTIC MODEL 25-B CHASSIS
RECEIVER MODELS CHELTENWOOD (251)- BRENTWOOD (253)- BRUCEWOOD (254)

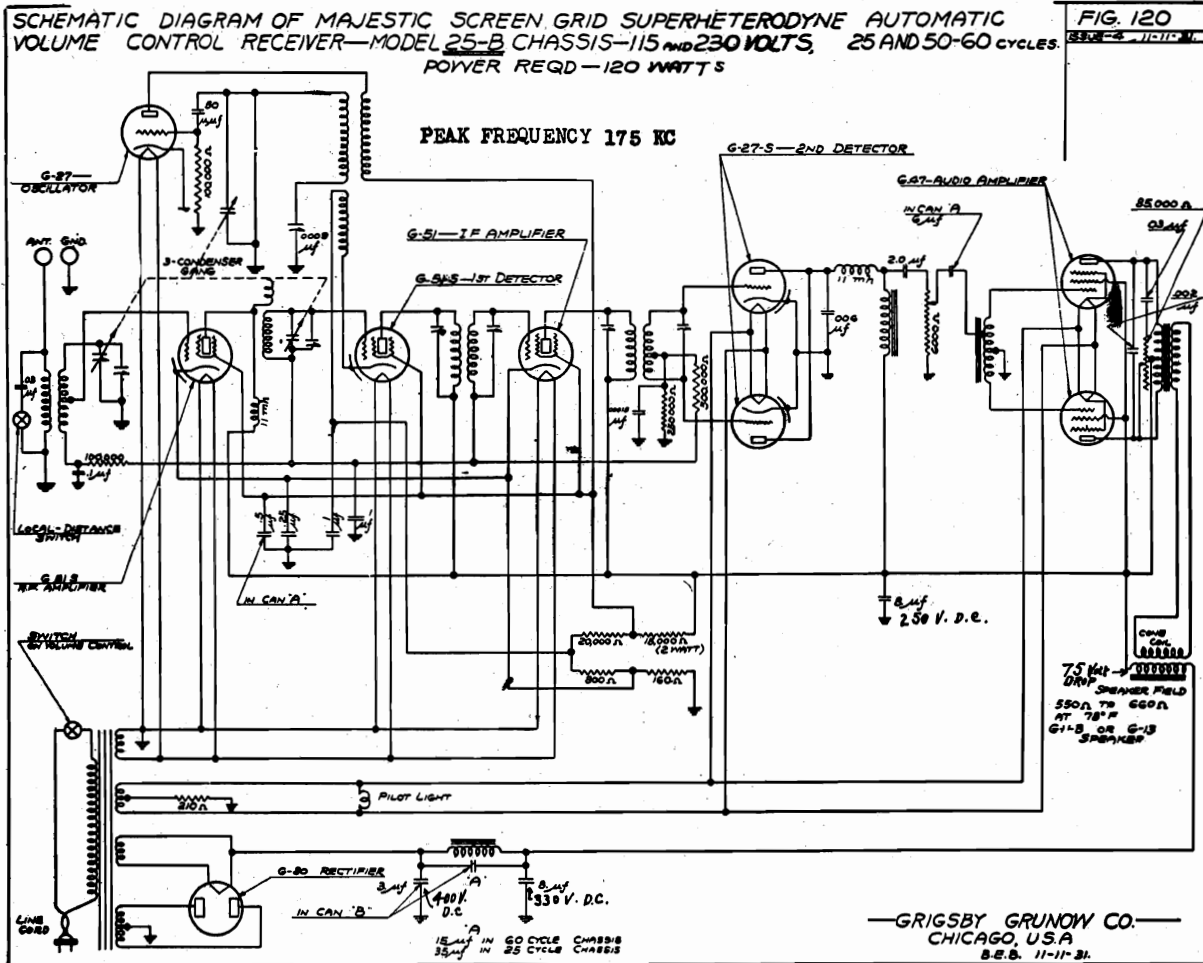

The audio system is tuned to give full bass response as low as forty cycles, also an image rejector circuit is used in the pre-selector to reduce image response.

Power Supply System

The power supply system on the Model 25B Chassis consists of a power transformer, G80 rectifier, filter choke (runed) speaker field 3 mfd paper condenser and two 8 mfd. electrolytic condensers.

Color Code for Model 25-B Power Transformer

- | | |
|--------------------------------|----------------------------------|
| Start of Primary..... Yellow | Center Tap No. 1 Heater... Red |
| Finish of Primary..... Yellow | Finish of No. 1 Heater... Black |
| Start of Anode..... Red | Start of No. 2 Heater... Yellow |
| Center Tap (Anode)... Black | Finish of No. 2 Heater... Yellow |
| Finish of Anode..... Red | Start 5 v. Fil..... Black |
| Start of No. 1 Heater... Black | Finish 5 v. Fil..... Black |

MODEL 25-B		Line 115 Volts			Vol. Contr. Max.			
TUBE	CIRCUIT	FIL.	PLATE	F.to GRND.	CATH.	CURRENT	S.G.VOLTS	S.G.CURRENT
G-51-S	R.F. Amp.	2.5	260	3	4.2	90	1.2
G-51-S	1st Det.	2.5	260	7	1.3	90	.4
G-27	Osc.	2.5	90	3.5
G-51-S	I.F.	2.5	260	3	5.	90	1.6
G-27-S	2nd Det.	2.5	135	16	14.
G-27-S	2nd Det.	2.5	135	16	14.
G-47	Power	2.5	250	16	30.	250	7.2
G-47	Power	2.5	250	16	30.	250	7.2
G-80	Rect.	5.	400	120 Total

MODEL 25-B
251, 253, 254
Chassis Views

GRIGSBY - GRUNOW CO.

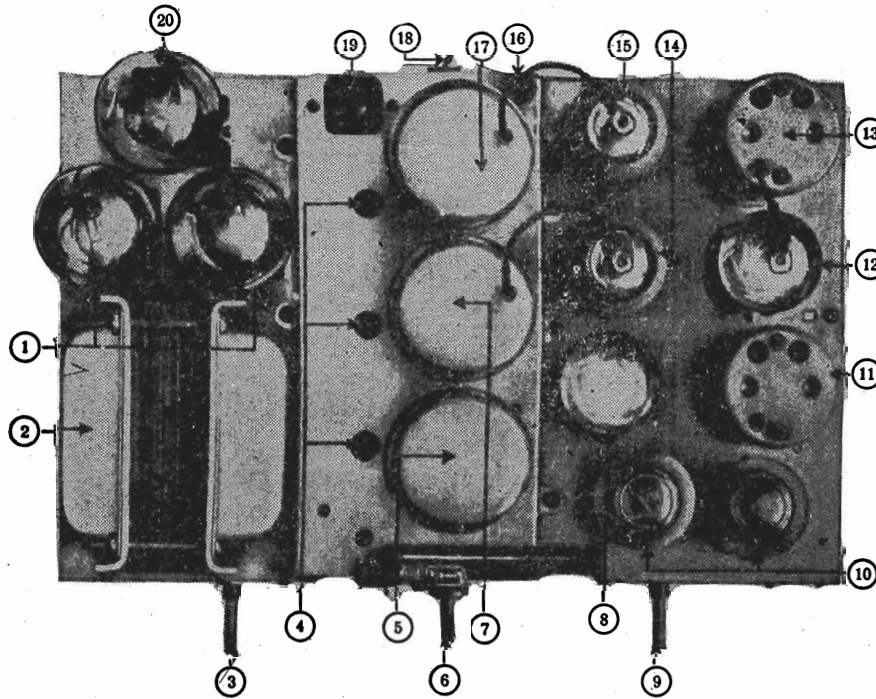

Top View of Model 25B Chassis

- | | | | |
|--------------------------------------|-------------------------------------|----------------------------------|--------------------------------|
| 1. G47 Pentode Audio Amplifier Tubes | 6. Tuning Control | 10. G-27-S Second Detector Tubes | 15. G-51-S R.F. Amplifier Tube |
| 2. Power Transformer | 7. R.F. Coil | 11. 2nd I. F. Transformer | 16. Ground Post |
| 3. Tone Control | 8. G27 Oscillator Tube | 12. G-51 I. F. Amplifier Tube | 17. Antenna Coil |
| 4. Aligning Condensers | 9. Volume Control and On-Off Switch | 13. First I. F. Transformer | 18. Local-Distance Switch |
| 5. Oscillator Coil | | 14. G-51-S 1st Detector Tube | 19. Antenna Post |
| | | | 20. G-80 Rectifier Tube |

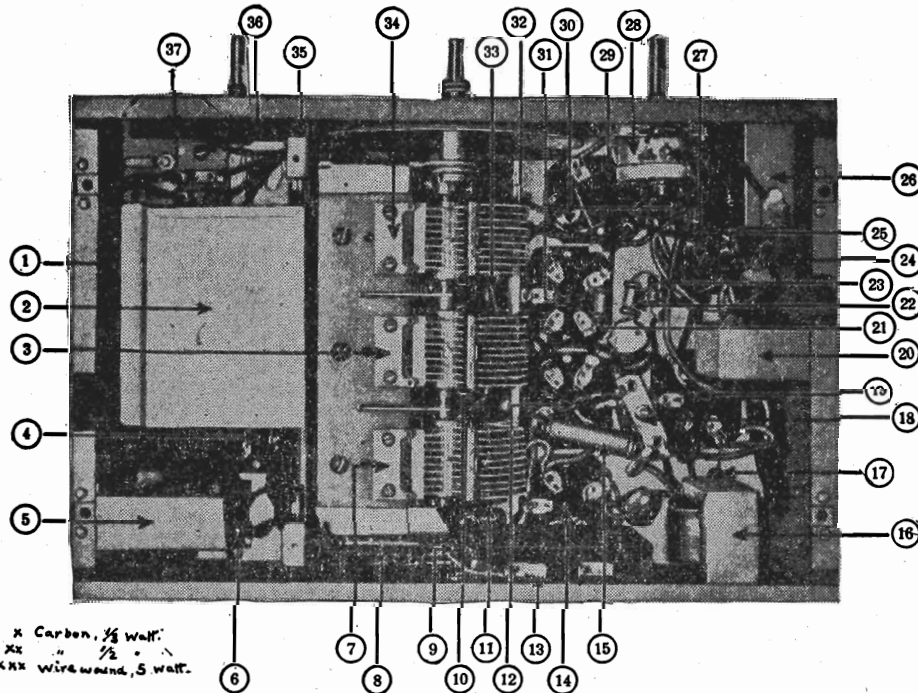

x Carbon, 1/2 watt.
xx " 1/2 " "
xxx wire wound, 5 watt.

Bottom View of Model 25B Chassis

- | | | | | |
|------------------------------|--|---|------------------------------------|-----------------------------------|
| 1. 8 mfd. Cond. (2) | 8. .03 mfd. Local-Distance Cond. (Cartridge) | 15. 15,000 Ohm Resistor | 26. "Can A" Cond. Assembly | 32. .0005 mfd. Mica Cond. |
| 2. 3 mfd. and .15 mfd. Cond. | 9. Local-Distance Switch | 16. Push-Pull Input Choke | 27. .00015 mfd. Mica Cond. | 33. .1 mfd. Cond. |
| 3. R. F. Stage Tuning Cond. | 10. 100,000 Ohm Resistor | 17. 160 Ohm Resistor | 28. Volume Control and Line Switch | 34. Oscillator Stage Tuning Cond. |
| 4. G-47 P.P. Audio Sockets | 11. .1 mfd. Cond. (Cartridge) | 18. R. F. Choke | 29. .006 Mfd. Mica Cond. | 35. Oscillator Tracking Cond. |
| 5. Filter Choke | 12. G-51-S First Det. Socket | 19. G-51-S I. F. Amplifier Det. Plate A. F. Choke | 30. G-27-S 2nd Det. Sockets | 36. Tone Control |
| 6. G-80 Rectifier Socket | 13. "Can C" Cond. Assembly | 20. 100,000 Ohm Resistor | 31. G27 Oscillator Socket | 37. .03 mfd. Tone Control Cond. |
| 7. Ant. Stage Tuning Cond. | 14. G-51-S R. F. Amplifier Socket | 21. 100,000 Ohm Resistor | | |
| | | 22. 250,000 Ohm Resistor | | |
| | | 23. 500,000 Ohm Resistor | | |
| | | 24. 800 Ohm Resistor | | |
| | | 25. 20,000 Ohm Resistor | | |

MODEL 35
351,353
Schematic

GRIGSBY - GRUNOW CO.

MODEL 35 CHASSIS
RECEIVER MODELS ABBEYWOOD (353) and COLLINGWOOD (351)

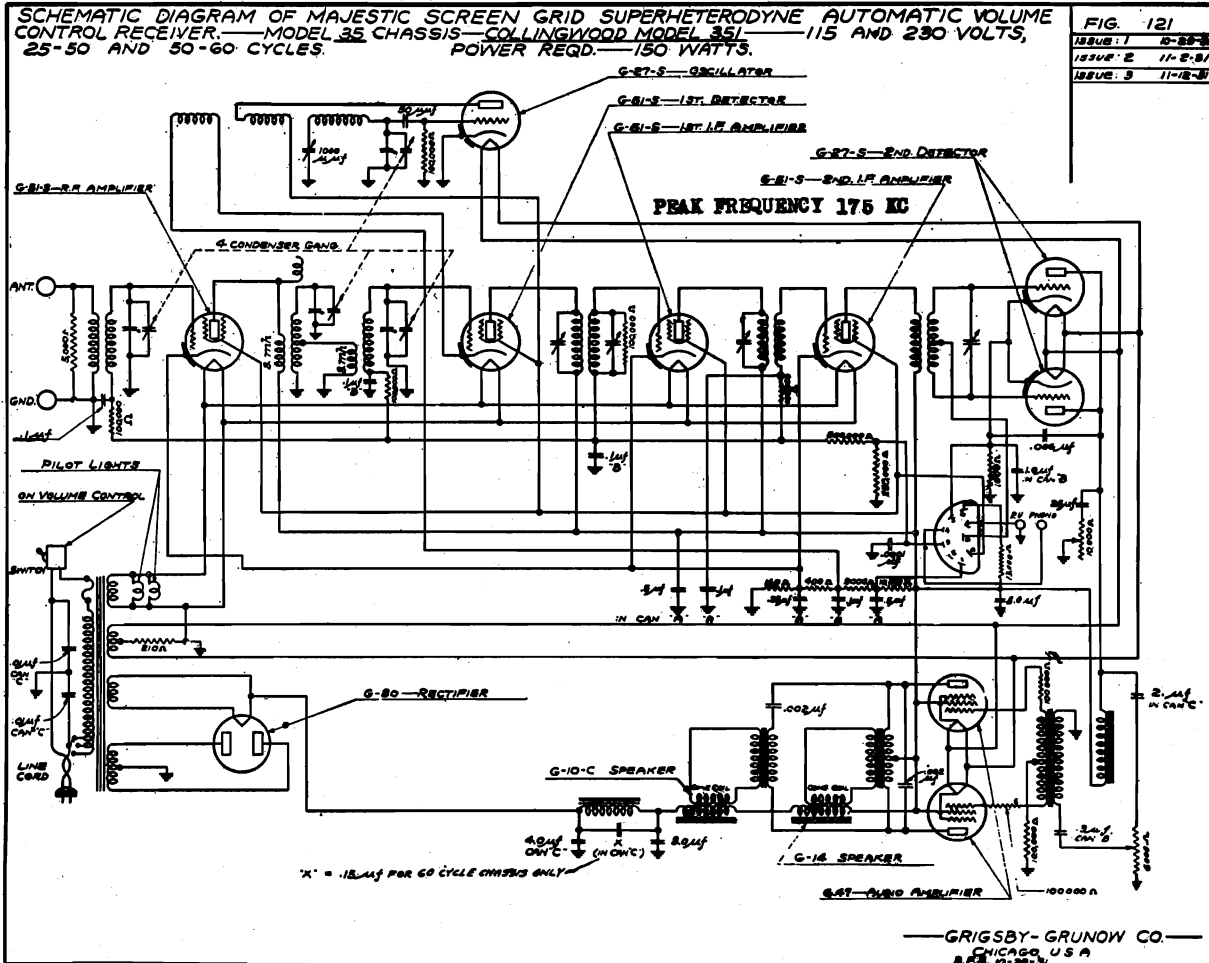

Radio-Phonograph Switch

Both the COLLINGWOOD and ABBEYWOOD Models have a radio-phonograph switch which is located below the central control or station selector. This switch is turned to the right for radio operation and to the left for phonograph operation. There are pick-up terminals on the Model 35 chassis employed in both these sets, although the COLLINGWOOD Model is not a combination receiver. There should always be a jumper across the pickup terminals when the pickup is not attached.

Power Supply System

The power supply system of the Model 35 chassis consists of a power transformer, G-80 rectifier, a filter choke which is tuned to hum frequency, a 4 mfd. paper condenser, and two 8 mfd. electrolytic condensers. The condenser employed across the filter choke is a .15 mfd. for sixty cycle operation, and a .35 mfd. for twenty-five cycle operation. The output from this filter section passes through the fields of both dynamic speakers which act as additional chokes to the filter circuit.

MODEL 35		Line 115 Volts						
TUBE	CIRCUIT	FIL.	PLATE	F.to GRND.	CATH.	CURRENT	S.G.VOLTS	S.G.CURRENT
G-51-S	R.F. Amp.	2.5	265	4	5	90	0.5
G-51-S	1st Det.	2.5	265	8	1	90	0.5
G-27	Osc.	2.5	90	4
H-51-S	1st I.F.	2.5	265	4	5	90	0.5
G-51-S	2nd I.F.	2.5	265	4	5	90	0.5
G-27-S	2nd Det.	2.5	115	12
G-27-S	2nd Det.	2.5	115	12
G-47	Power	2.5	250	16.5	32	260	7
G-47	Power	2.5	250	16.5	32	260	7
G-80	Rect.	5.0	130 total

Color Code for Model 35 Power Transformer

Start of No. 1 Heater.....Black
Center Tap No. 1 Heater.....Red
Finish of No. 1 Heater.....Black
Start of No. 2 Heater.....Yellow
Finish of No. 2 Heater.....Black
Start G-80 Filament.....Black
Finish G-80 Filament.....Black

Start of Primary.....Black
1st Tap of Primary.....Green
2nd Tap of Primary.....Yellow
Finish of Primary.....Blue
Start of Anode.....Red
Center Tap (Anode).....Black
Finish of Anode.....Red

GRIGSBY - GRUNOW CO.

MODEL 25-B
MODEL 35
Alignment

Technical Data Models 25B and 35 Chassis

Procedure for Alignment

WARNING: The Power Line shall never be connected to the receiver until the speaker and tubes are connected in the receiver.

The receiver shall be aligned with the volume control set at maximum and input reduced to keep output below 1 watt.

1. Supply 175 K.C. on 1st detector grid and adjust all I.F. tuning condensers to give maximum sensitivity.
2. Set dial at 1500 K.C. and line up all radio frequency circuits on 1500 K.C. signal for maximum output.
3. Set dial at 550 K.C. and adjust oscillator tracking condenser for maximum sensitivity with 550 K.C. feeding into the set. For each adjustment of the oscillator tracking condenser, there will be a different dial setting for maximum sensitivity. The combination of tracking condenser adjustment and dial setting which gives maximum sensitivity, disregarding calibration is the correct adjustment. If this adjustment falls within 5 K.C. of the 550 K.C. calibration point, readjust trimmers at 1500 K.C. and check dial calibration at 1000 K.C.

Each Receiver Must Be Aligned for Maximum Sensitivity. Check volume control throughout its range for noise, open or short circuit and irregularity of control operation. Check acoustic control over entire range for noise, open, short circuit and operation.

Automatic Volume Control System.

The manual control is a 6,000 ohm potentiometer between second detectors and output tubes, operating entirely independent of the automatic control.

Automatic control is accomplished by applying the second detector grid bias on the R.F. Detector and I. F. Stages to control their amplification, and by the inherent control of audio amplification in the second detector stage, due to the same bias.

Sensitivity

In cases where low sensitivity is encountered, the first step taken to remedy the condition, should be to check the G51S Tubes, which may be drawing abnormal grid current. This procedure should always be taken prior to any attempt to remedy by aligning the condenser gang.

Method of Biasing

The necessary bias obtained on the R. F., First Detector and I. F. is obtained from a bleeder circuit. The Oscillator is self-biasing with grid current drop across the 100,000 ohm grid resistor. The second detectors are self-biasing from a grid current drop across the 250,000 ohm grid resistor. The pentodes are also self-biasing by the 110 ohm wire-wound resistor in the filament circuit.

"Off" and "On" Line Switch

The "Off" and "On" Line Switch is attached to the volume control shaft. Turning the volume control completely to the left shuts the receiver off. The first fifteen degrees rotation of the control to the right will turn the receiver on. The balance of rotation to the right controls the volume of the receiver.

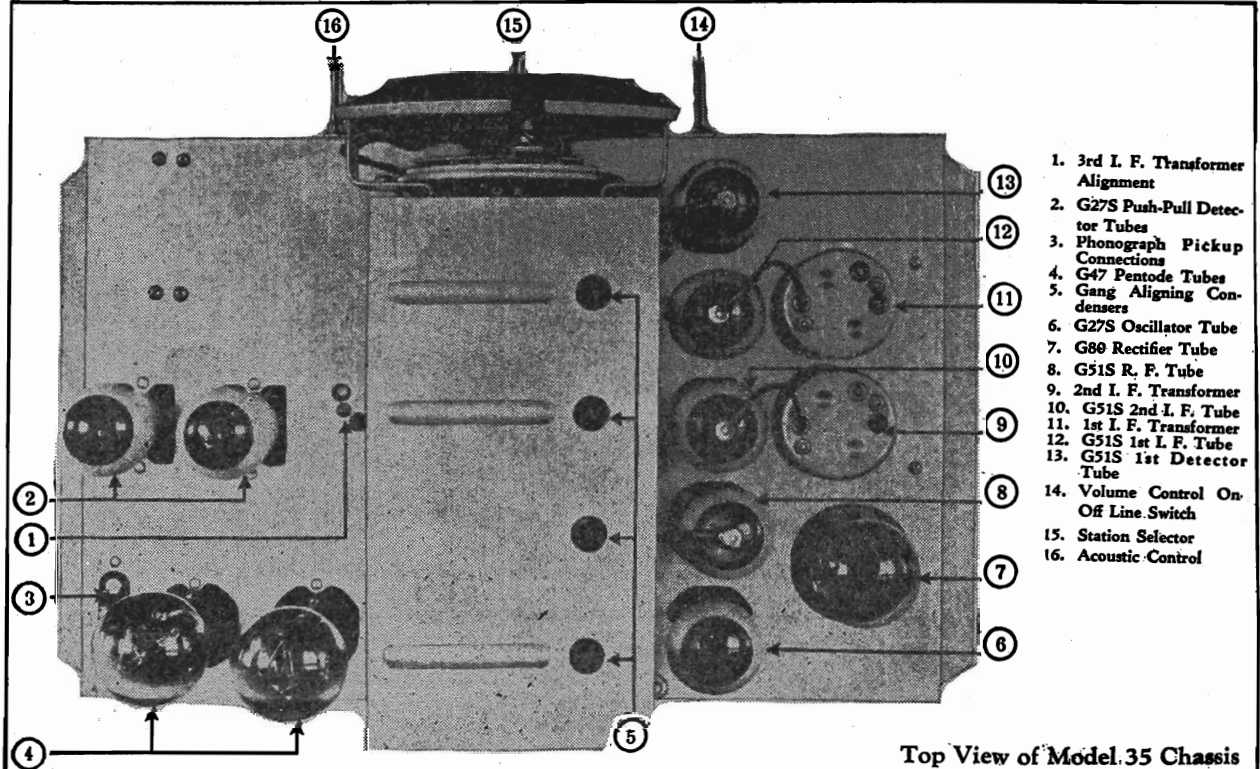

Top View of Model 35 Chassis

MODEL 35
351, 353
Chassis Views

GRIGSBY - GRUNOW CO.

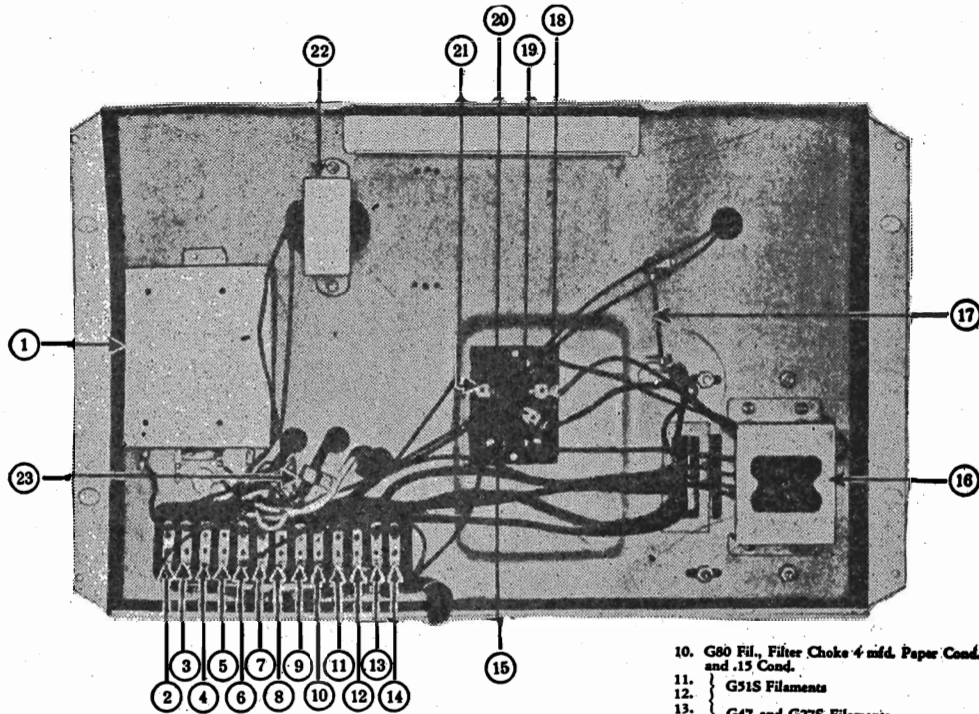

View Showing Power Supply Circuit of Model 35 Chassis

- | | |
|--|--|
| 1. 2-8 mfd. Electrolytic Condensers | 5. 110 V. Line Cord—On and Off Switch and .01 Cond. |
| 2. 285 V. to G47 Screens, 8 mfd. Electrolytic Cond. Det. Audio Choke and G14 Speaker Field | 6. 110 V. Line Cord—Primary Switch and .01 Cond. |
| 3. 2 mfd. Cond. Det. Audio Choke and Second Det. Plates | 7. G47 Plate and Input to Speakers |
| 4. 2 mfd. Cond. and Volume Control | 8. G47 Plate and Input to Speakers |
| | 9. Power Filter Choke G-10C Speaker Field, .15 Cond. and 8 mfd. Electrolytic Cond. |

- | |
|---|
| 10. G80 Fil., Filter Choke 4 mfd. Paper Cond. and .15 Cond. |
| 11. G51S Filaments |
| 12. G47 and G27S Filaments |
| 13. Fuse |
| 14. G80 Rectifier Socket |
| 15. 210 Ohm Resistor |
| 16. 125 V. Primary Tap |
| 17. 115 V. Primary Tap |
| 18. 105 V. Primary Tap |
| 19. Line |
| 20. Audio Frequency Choke |
| 21. Junction G10C—G14 Speaker Fields |

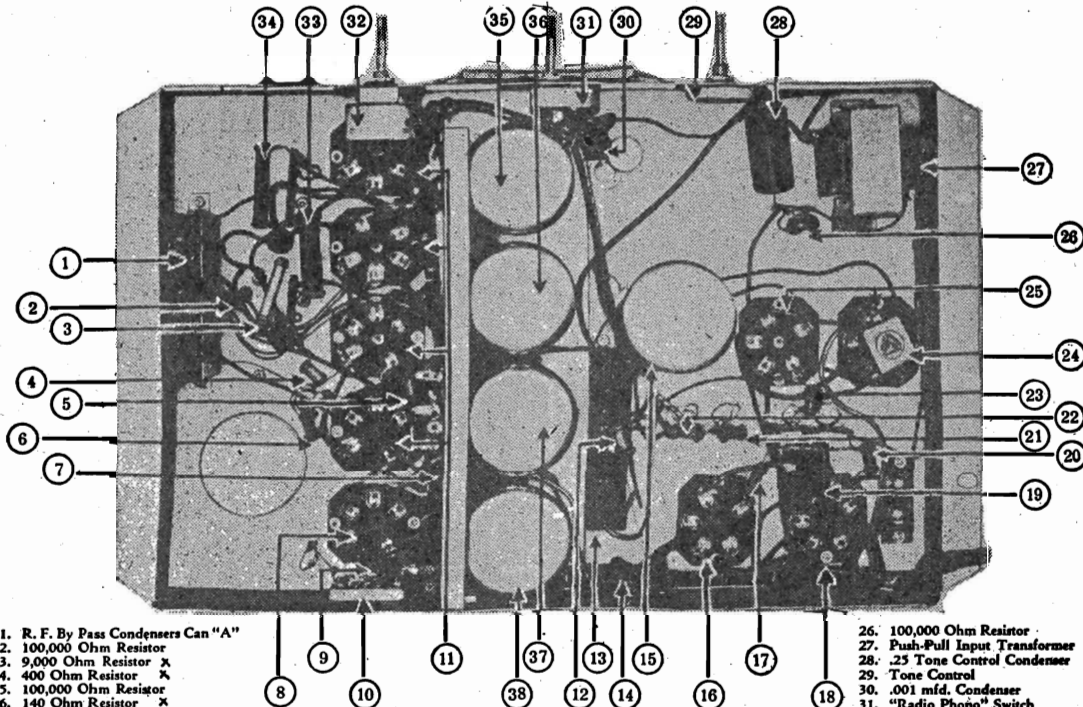

Interior View of Model 35 Chassis

- | |
|-------------------------------------|
| 1. R. F. By Pass Condensers Can "A" |
| 2. 100,000 Ohm Resistor |
| 3. 9,000 Ohm Resistor X |
| 4. 400 Ohm Resistor X |
| 5. 100,000 Ohm Resistor |
| 6. 140 Ohm Resistor X |
| 7. .1 mfd. Condenser |
| 8. G27S Oscillator Tube Socket |
| 9. 100,000 Ohm Resistor |
| 10. Oscillator Tracking Condenser |
| 11. G51S Tube Sockets |
| 12. 100,000 Ohm Resistor |
| 13. R. F. By Pass Condenser Can "B" |
| 14. 5000 Ohm Resistor X |
| 15. 3rd I. F. Transformer |

- | |
|---------------------------------|
| 16. } G47S Tube Sockets |
| 17. } G47S Tube Sockets |
| 18. } G47S Tube Sockets |
| 19. .002 mfd. Condenser (Mica.) |
| 20. 100,000 Ohm Resistor |

- | |
|-------------------------------------|
| 21. 250,000 Ohm Resistor X |
| 22. 500,000 Ohm Resistor X |
| 23. 1000 Ohm Resistor X |
| 24. .006 mfd. Condenser (Mica.) |
| 25. G27S Push-Pull Detector Sockets |

- | |
|--|
| 26. 100,000 Ohm Resistor |
| 27. Push-Pull Input Transformer |
| 28. .25 Tone Control Condenser |
| 29. Tone Control |
| 30. .001 mfd. Condenser |
| 31. "Radio Phono" Switch |
| 32. Manual Volume Control (Off and On) Line Switch |
| 33. 10,000 Ohm Resistor } wire |
| 34. 13,000 Ohm Resistor } sound |
| 35. Link R. F. Coil |
| 36. R. F. Coil |
| 37. Antenna Coil |
| 38. Oscillator Coil |

GRIGSBY - GRUNOW CO.

MAJESTIC CHASSIS MODELS 25-B and 35

MODEL 25-B
MODEL 35
Speaker Conn.

G-10-C Speaker
COLLINGWOOD Model

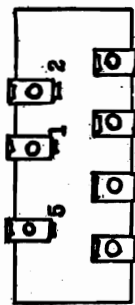

- 1 Primary Plate Lead Terminal
- 2 .002 Cond. Plate Terminal
- 3 Speaker Field Terminals
- 4 Voice Coil & Secondary Junction
- 5 Primary & .002 Cond. Junction

G-14 Speaker
COLLINGWOOD Model

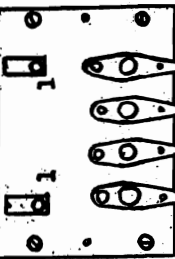

- 1 Voice Coil & Output Sec. Junct.
- 2 Field Coil & Primary Tap Junct.
- 3 Primary Plate Lead Terminals
Field Coil Terminal

Models G-10-C, G-13-B, G-14 and G-14-B Dynamic Speakers
Employed in Models Collingwood and Abbeywood

Both the COLLINGWOOD and ABBEYWOOD Models are equipped with twin speakers. The COLLINGWOOD Model employs the G-10-C, a small dynamic speaker (field resistance 200 ohms) for the high notes and the G-14, a large dynamic speaker (field resistance 750 ohms) for the low notes. The ABBEYWOOD Model employs the G-13-B dynamic speaker (field resistance 300 ohms) for the high notes and the G-14-B dynamic speaker (field resistance 550 ohms) for the low notes. The voice coil of the G-14-B is excited by one-half of the secondary of the output transformer which is located in the base of the speaker, and the voice coil of the G-13-B is excited by the other one-half of the same secondary. These speakers operating simultaneously produce an almost flat audio frequency response curve that gives these receivers a truly faithful reproduction.

G-13 Speaker
BRENTWOOD and BRUCEWOOD Models

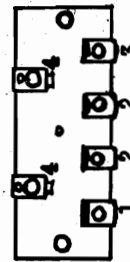

- 1 Field Coil Terminal
- 2 Voice Coil & Output Sec. Junct.
- 3 Field Coil & Primary Tap Junct.
- 4 Primary Plate Lead Terminals

Models G-11-B and G-13 Dynamic Speakers

Employed in Models Cheltenham, Brentwood and Brucewood

The Models G-11-B and G-13 Dynamic Speakers have a field resistance of 570 ohms at 78° F. The G-11-B Speaker which is employed in the Cheltenham Model, has a field structure of heavy "U" construction, and a 9.5" paper weight cone which responds readily to the slightest excitation. The output transformer with its terminal board is rigidly fastened to the cone housing. The G-13 speaker, which is employed in the Brentwood and Brucewood Models, has a field structure of heavy "U" construction mounted on a 6" base which is also used as a case for the output transformer. The 12" cone is a special made paper weight cone which responds readily to the slightest excitation.

G-14-B Speaker
ABBEYWOOD Model

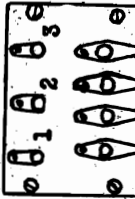

- 1 Output Sec. & Voice Coil of G-14-B & G-13-B Junction
- 2 Voice Coil of G-13-B & Output Secondary Junction
- 3 Voice Coil of G-14-B & Output Secondary Junction
- 4 Field Coil & Primary Tap Junct.
- 5 Primary Plate Lead Terminals
- 6 Field Coil Terminals

G-13-B Speaker
ABBEYWOOD Model

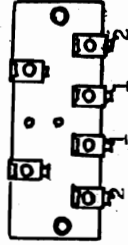

- 1 Voice Coil & Output Sec. Junct.
- 2 Field Coil Terminals

CHASSIS	25-B
DYNAMIC SPEAKER	
MODEL	G-10-C
"	G-13-B
"	G-14
"	G-14-B
CHASSIS	35
DYNAMIC SPEAKER	
MODEL	G-11-B
"	G-13

MODEL 353
Record Changer
Notes

GRIGSBY - GRUNOW CO.

Instructions for Care and Operation of Automatic Record Changer Employed in the Majestic Model 353 Receiver

IMPORTANT.—The following instruction should be used in operating the MAJESTIC Automatic Record Changer employed in the Model 353 Abbeywood Receiver.

WARNING.—Before attempting to operate the automatic record changer, three screws which pass through the base plate of the record changer and the wood shelf, should be loosened so that the chassis is resting freely on the rubber cushions.

WARNING.—At no time for any reason should the turntable be stopped by hand. If this warning is not adhered to, serious damage may result.

RECORDS.—It is possible to play the two types of records available for home entertainment, that is, the ordinary records and the new long playing records. Each of these two types can be obtained in both twelve and ten inch diameter. The approximate playing time of these records is as follows:

Ordinary Records:

10 inch—2½ minutes.
12 inch—3½ minutes.

New Long Playing Records:

10 inch—10 minutes.
12 inch—15 minutes.

SPEED.—The standard record turns at a speed of 78 revolutions per minute, whereas the long playing record turns at the rate of 33 1/3 revolutions per minute. The mechanism is provided with a speed control lever to give either of these speeds, as required.

SWITCHES.—The line switch for the phonograph motor is located near the front of the turn table.

Directly under the main tuning dial is the "Radio-Phonograph" switch, which should be thrown to phonograph position for record playing. The line switch for the radio receiver is incorporated in the volume control assembly, which is located to the left of the phonograph switch.

NEEDLES.—The long playing records should be played using only the special needles designed for this type of record. After the special needle has once been removed from the pick-up head, do not use it again. Replace with a new one.

Do not play ordinary records with the special needle designed for long playing records.

Instructions for Setting Selector Device

It will be noted that to the right of the turn table there is a selector lever for the purpose of playing ten inch records automatic, ten inch records repeat, twelve inch records repeat, and universal or manual operation.

10" AUTOMATIC.—This is the only position in which the ten inch records are changed automatically.

10" REPEAT.—In this position, the mechanism will repeat the playing of the same record as many times as desired.

12" REPEAT.—The mechanism in this position will keep repeating a 12" standard record. Do not, however, attempt to repeat a 12" long playing record as it should be played manually with the lever in the universal position.

"UNIVERSAL."—In this position, the automatic changing and the repeat mechanism are not in operation, and the playing is controlled manually as with the ordinary phonograph. This position should always be used for playing the 12" long playing record and may be used for playing standard records.

Instructions for Operating Automatic Record Changer

Select the desired records and place them carefully in the record holder or magazine. The record at the bottom of the magazine will be the first one to be played.

The automatic changing magazine handles from one to ten of the 10" records. Do not mix standard records with long playing records in the magazine for automatic playing, as each type requires a different speed and a different type of needle.

It is best to place the first record on the table by hand and start the needle very carefully in the first groove with the selector lever in the "Universal" position; then the lever may be turned to the automatic position if desired, after which the changer will operate as outlined in paragraph II under "Instructions for Setting Selector Device." This procedure protects the needle and the record, and assures longer life for both.

REJECT LEVER.—While playing in the automatic position, if it is desired to interrupt the record and to play the following one, pull forward the reject lever which is located to the right of the turn table. This will cause the mechanism to go through a complete cycle of changing the record.

RELOADING.—When all of the records have been played through, and the magazine is empty, the mechanism will repeat the last record over and over. In reloading the magazine, switch off the motor at the time the magazine has travelled to the extreme left position, and carefully remove the stack of records from the turn table. Then replace them in the magazine in any desired sequence, with the side facing up which you desire to play. *The magazine may be swung up and down, but do not try to force it sideways manually.*

ARM REST.—When changing records, the pick-up should be placed on the rest, to the right. If it cannot be placed there without straining, this is a sign that the automatic mechanism has not completed its cycle. In this case, hold the pick-up loosely, turn on the motor switch and wait until the record magazine has moved to the extreme left, which will allow the pick-up to be placed on its rest.

Instructions for Operating Manually

By placing the lever in the "UNIVERSAL" position, the records will be played manually. The 12 inch long playing records should always be played in this position.

Oiling

Every two or three months, the turn table should be removed and three or four drops of oil placed in each of the six holes provided.

GRIGSBY - GRUNOW CO.

MODEL 110

All leads marked "A" plus signify the ungrounded side of the car battery, and not necessarily the positive side.

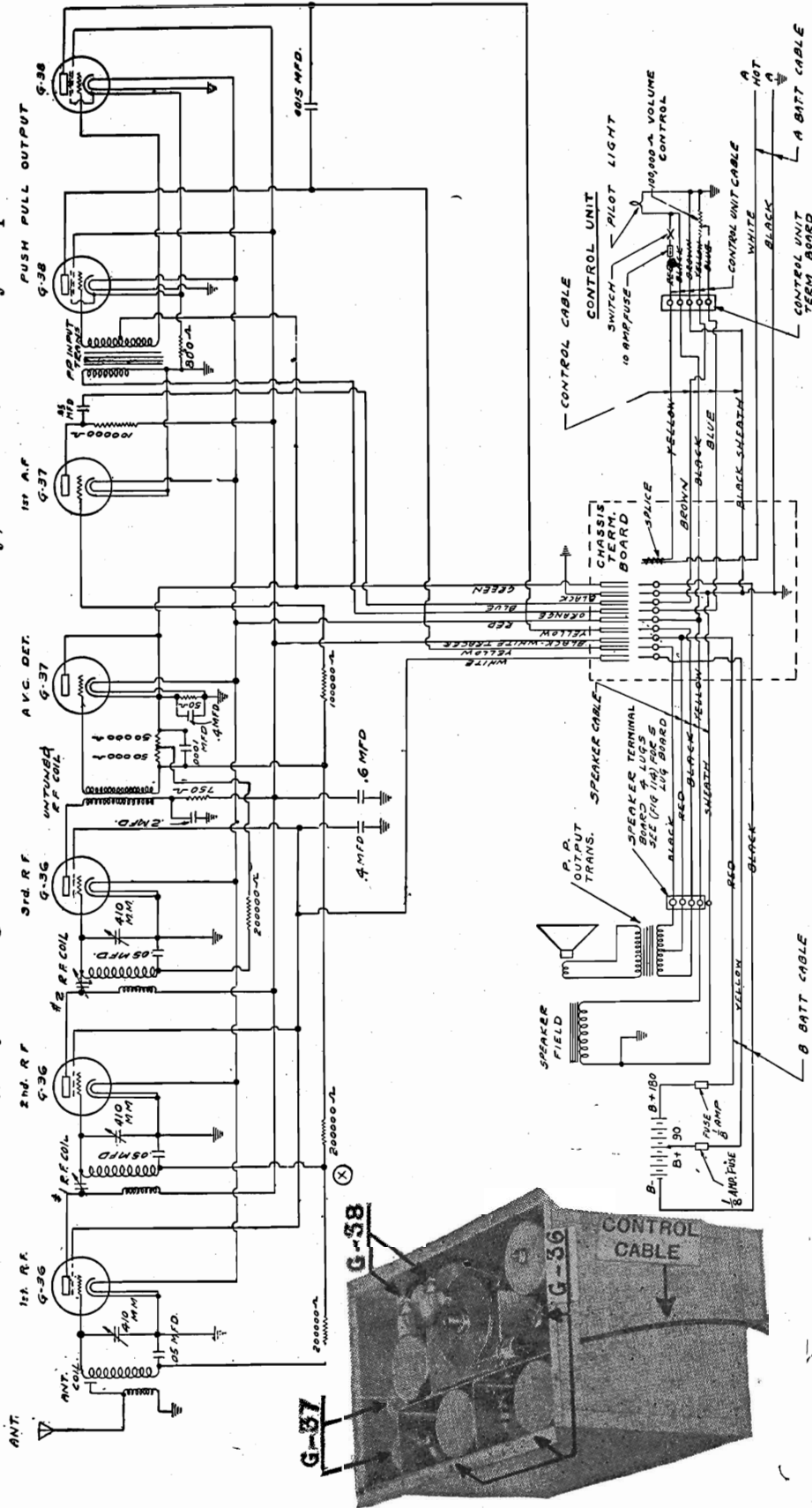

Note on Alignment of Gang Condenser: Should a receiver need realignment in the field, a station should be tuned in at approximately 1300 kilocycles and the alignment made in the usual manner. In case one alignment condenser will not indicate a peak of sensitivity, slightly advance or retard the tuning control and proceed to readjust the alignment condenser as before.

Note on Automatic Volume Control System: The Model 110 chassis utilizes an automatic volume control system in combination with a diode detector, the G-37 detector serving both functions.

Majestic Model 110
Auto Radio

MODEL 120
Schematic

GRIGSBY - GRUNOW CO.

IF PEAK 175 KC.

BIAS VOLTAGES

Volume Control at Maximum	
R.F.	3 volts
Osc.	0 volts
1st Det.	8 volts
I. F.	3 volts
2nd Det.	8 volts
Pentode	13.5 volts

Volume Control at Minimum

R.F.	11 volts
Osc.	0 volts
1st Det.	14 volts
I. F.	3 volts
2nd Det.	8 volts
Pentode	13.5 volts

SCHEMATIC DIAGRAM OF MAJESTIC SCREEN GRID SUPERHETRODYNE HOME BATTERY RECEIVER MODEL -120

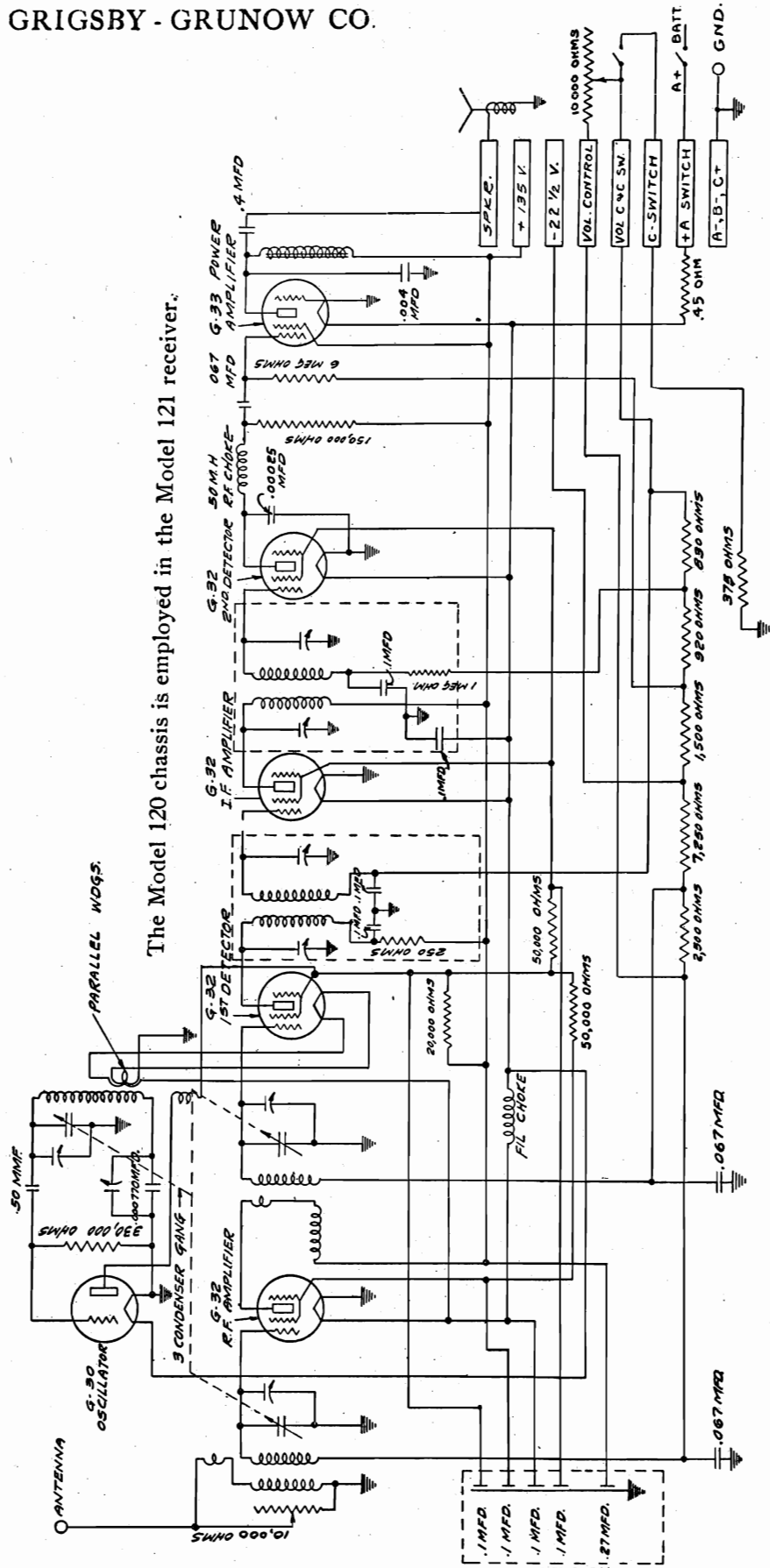

MODEL 120
Chassis View

GRIGSBY - GRUNOW CO.

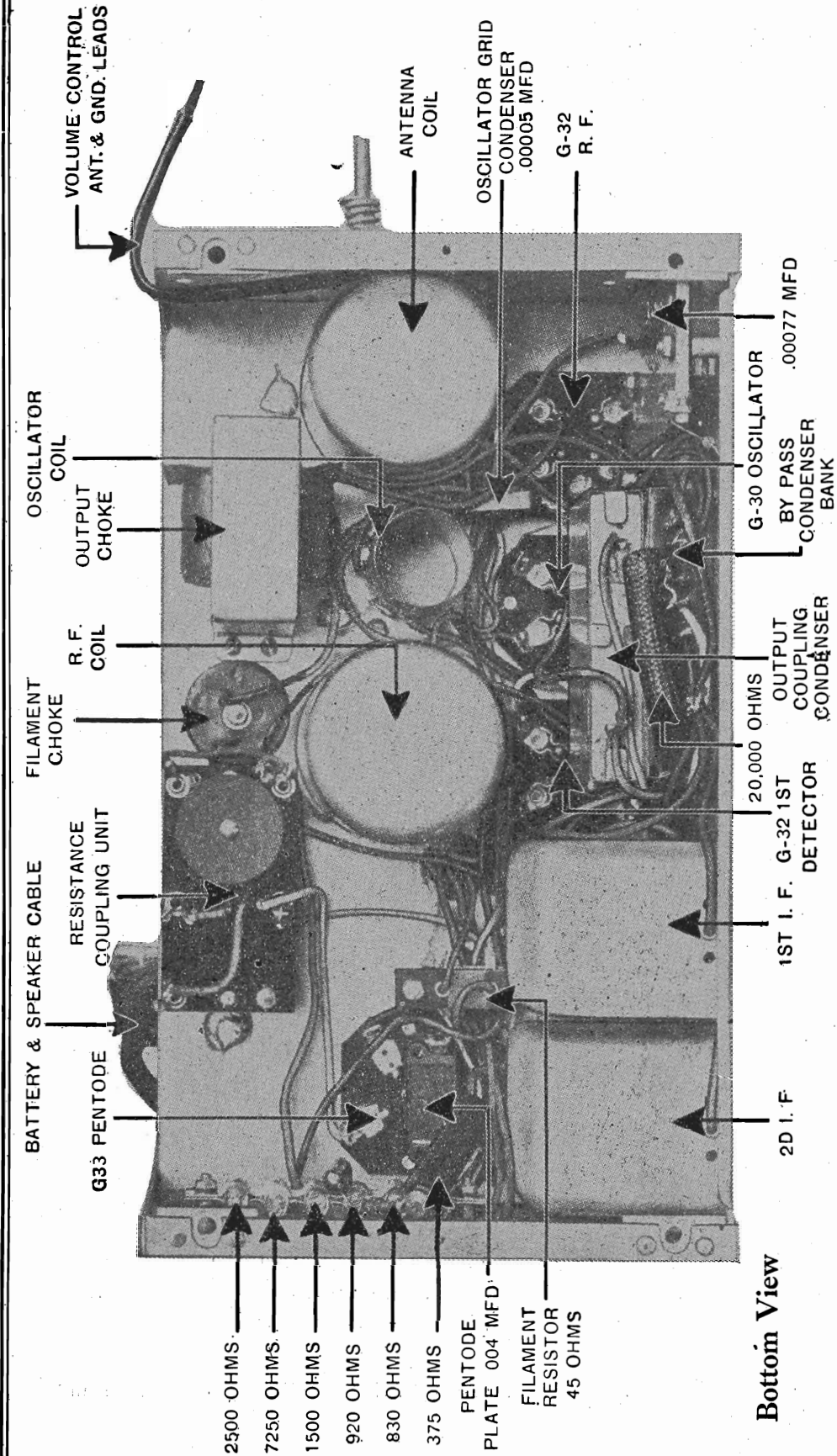

Bottom View

Volume Control and Switch Connections

- Antenna section of volume control—Red and Black.
- "C" bias section of volume control—Blue and Yellow.
- "A" battery side of switch—Red.
- Jumper switch to volume control—Blue.
- Switch to "C" bias—White.

Battery Connections

- 3 wire cable plus 135 volts—Red. minus 22½ volts—Green. plus "C" minus "B"—Black.
- 2 wire cable to speaker—Red and Black and Red. minus "A" Black.

Model 120 Chassis

MODEL 120
Notes

GRIGSBY - GRUNOW CO.

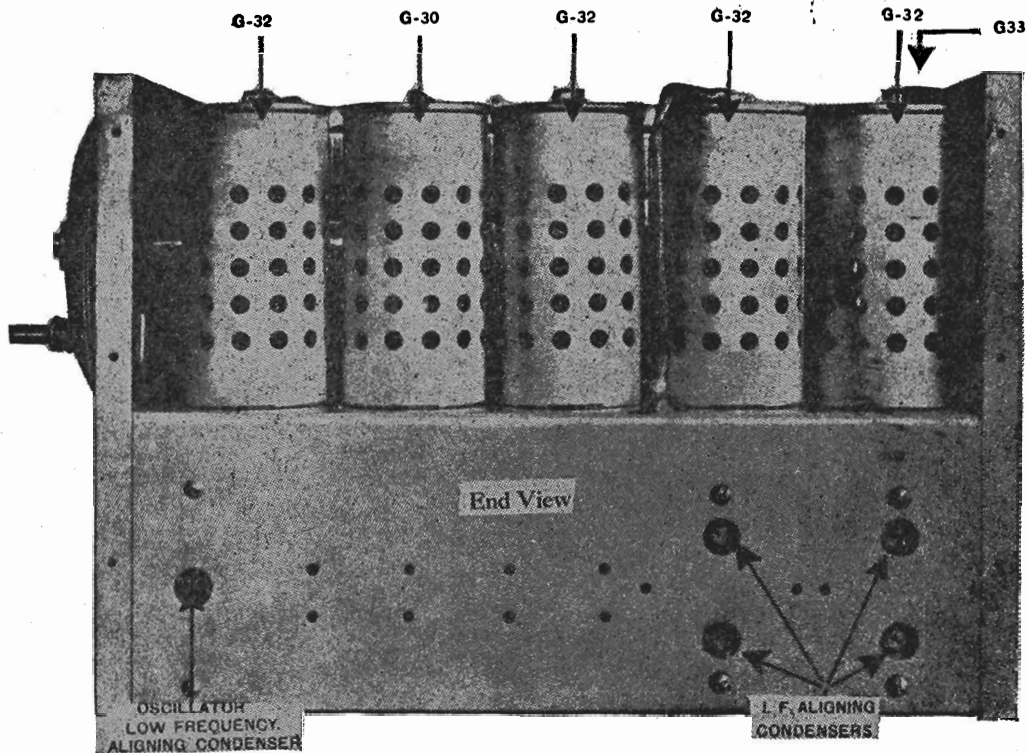

120 CHASSIS

I. F. Transformers Alignment

1. Connect oscillator for intermediate frequency alignment and set it in operation.
2. Align each aligning condenser on the intermediate frequency transformers to give maximum signal output.
3. After all four condensers have been aligned at 175 kilocycles, this stage should not be again adjusted.

R. F. and Oscillator Alignment

1. Tune in station in the vicinity of 1,500 kilocycles, or put output of local oscillator (if available) into receiver
2. Align R. F. stages and oscillator tuning condenser. The position of these condensers is shown on illustrated photograph in this manual.

Oscillator Tracking Condenser Alignment

1. Tune in local oscillator to 600 kilocycles.
2. Adjust both tuning control and tracking condenser simultaneously to give maximum signal as noted on output meter. This will be obtained by rocking tuning control across resonance point while adjusting tracking condenser to give maximum output at the point of resonance. This operation cannot be performed without local oscillator and output meter.

Check

Check the alignment previously made of R. F. and oscillator aligning condensers in the vicinity of 1,500 kilocycles.

GULBRANSEN CO.

MODEL 13
Schematic

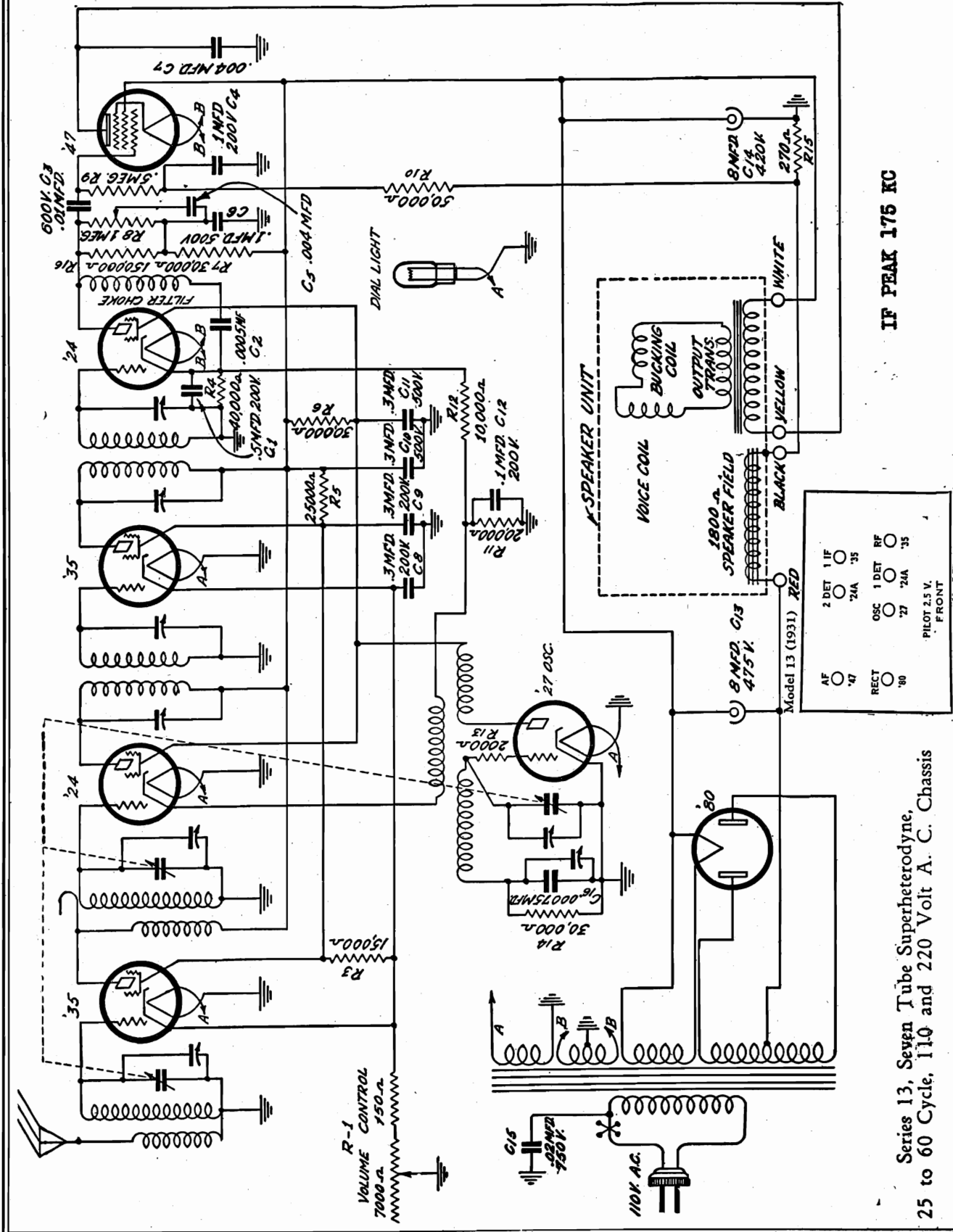

IF PEAK 175 KC

Series 13, Seven Tube Superheterodyne,
25 to 60 Cycle, 110 and 220 Volt A. C. Chassis

MODEL 13
Voltage-Data.

GULBRANSEN CO.

POWER TRANSFORMER

One side of the 110 volt line is connected to the terminal marked "Pri. 2" and the other side to one switch terminal on the receiver. The switch completes the circuit to the "Pri. 1" terminal.

The 25 cycle transformer is especially designed for operation on 110 volt, 25 cycle current but may also be used on any 110 volt, A.C. supply having a higher frequency.

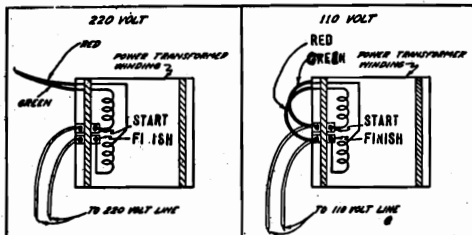

Receivers having a 220 volt, 40 to 60 cycle power transformer may also be operated on 110 volt, 40 to 60 cycle current when connections on the primary of the transformer have been changed.

The red and green wires shown in the sketch, (220 volt) must be disconnected and then connected as shown in the 110 volt sketch. No other changes are necessary.

CONDENSERS AND RESISTORS

Three blocks contain the majority of condensers. The choke in the plate circuit of the second detector tube is also contained in one of these blocks. The common leads of condenser blocks No. 1 and No. 2 are grounded. C1, C4, and C6 in block No. 3 have a common lead which is grounded, and the choke and C3 in this block have a common lead connected to the plate of the 2nd detector.

ANALYZER CHART

All voltages taken with a 1,000 ohm per volt voltmeter on the scale indicated in the column headed "Meter Scale." Turn the volume all the way on and connect the antenna and ground leads together. The grid, plate, and screen grid voltages are measured to cathode of the '24 and '35 tubes and to filament of the '47 tube.

The grid voltage on the '27 oscillator cannot be taken except with a very sensitive, low scale voltmeter. The voltage is approximately .05 volts when the A.C. line voltage is 110 volts.

Tube	Circuit	Meter Scale	110 V.
R.F. (Ant) '35	Grid	0—10	1.9
	Screen Grid	0—100	63.
	Plate	0—250	225.
1st Det. '24	Grid	0—25	14.5
	Screen Grid	0—100	65.
	Plate	0—250	220.
Int. '35	Grid	0—10	1.9
	Screen Grid	0—100	63.
	Plate	0—250	225.
2nd Det. '24	Grid	0—25	14.5
	Screen Grid	0—100	65.
	Plate	0—250	135.
Osc. '27	Grid Plate	0—100	80.
Aud. '47 (See Caution Above)	Grid	0—10	2.7
	Accelerating	0—250	225.
	Plate	0—250	205.
'80 Rect.	Filament to Ground	0—1000	233.

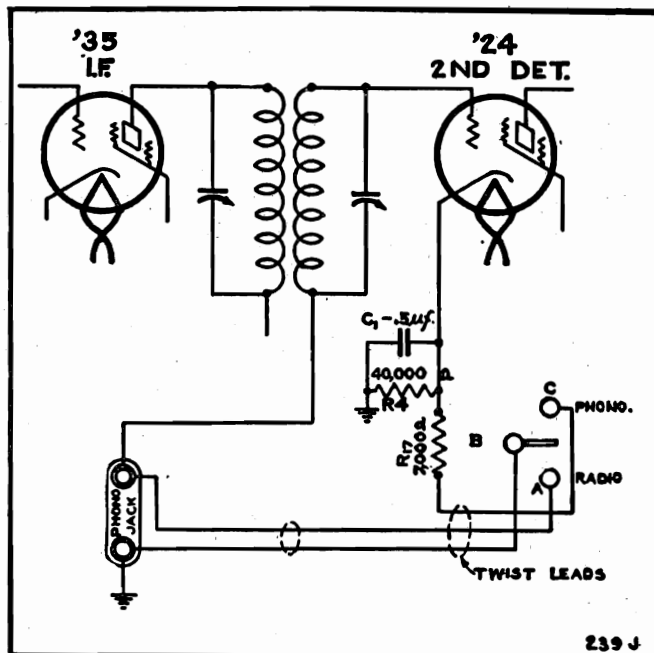

Phonograph Hook-up

SERIES 13 SUPERHETERODYNE

**MODEL 13
Color Code
Data**

GULBRANSEN CO.

RESISTORS

Diagram Key	Part No.	Resistance in ohms	Type	IDENTIFICATION	
				Base	Dot
R1	P-90976		Vol. Cont.		
R1	P-90978		Vol. Cont.		
R3	P-90905-B	15,000	Carbon	With Phonograph Switch	Green
R4	P-90916-B	40,000	Carbon	Brown	Orange
R5	P-90927-A	25,000	Carbon	Yellow	Black
R6	P-90926-A	30,000	Carbon	Red	Orange
R7	P-90956	30,000	Carbon	Orange	Black
R8	P-90977	1 Meg.	Tone Cont.	Orange	Black
R9	P-90938-A	500,000	Carbon	Green	Black
R10	P-90941-A	50,000	Carbon	Green	Black
R11	P-90959-A	20,000	Carbon	Red	Black
R12	P-90930-C	10,000	Carbon	Brown	Black
R13	P-90906-B	2,000	Carbon	Red	Black
R14	P-90956-A	30,000	Carbon	Orange	Black
R15	P-90975-A	270	Candohm		Orange
R16	P-90963-A	150,000	Carbon	Brown	Green
R17	P-90979	7,000	Carbon	Lavender	Black

For phonograph installation

CONDENSERS

Key No.	Part No.	Capacity	Type	Voltage Rating	Identification Mark
C12	P-80857-A	1 mfd.	Block	200 V.	White, Green Tr.
C8	Block	3 mfd.	Block	200 V	Brown
C9	No. 1	3 mfd.	Block	200 V	White, Red Tr
C15		02 mfd.	Block	750 V	Green
C10	P-80858	3 mfd.	Block	500 V	Brown
C11	Block No. 2	3 mfd.	Block	500 V.	Yellow
C1	P-80859-C	5 mfd.	Block	200 V	White and Red
C3	Block	01 mfd.	Block	600 V	White, Red Tr
C6	No. 3	1 mfd.	Block	500 V	Blue
C4		1 mfd.	Block	200 V	Yellow and Red
Choke					White, Green Tr
C2	P-80855	0005 mfd.	Moulded		Red
C5	P-80860	004 mfd.	Moulded		Tan
C7	P-80860	004 mfd.	Moulded		Tan
C13	P-80848-Hi.	8.0 mfd.	Electrolytic		Red
C14	P-80849-Lo.	8.0 mfd.	Electrolytic		Green
C16	P-80856	00075 mfd.	Moulded		Violet
	P-80842-D	Complete Gang Assembly with Shield (No Dial Assembly)			

SERIES 13 SUPERHETERODYNE

PHONO RADIO INSTALLATION

When phonograph equipment is to be connected to a receiver, the installation should be of a permanent nature. The circuit shown in Fig. 2 is the best possible method of permanently connecting phonograph equipment to this chassis. The circuit consists of a pickup with self-contained volume control, connected in the grid circuit of the second detector tube.

PICKUP AND PHONO TRANSFORMER

To obtain good tone and volume, a pickup with medium or low impedance and a transformer are recommended for use with this receiver. A pickup with high impedance should be used when a transformer is not available.

INSTALLATION

The following parts must be supplied from the factory to make the installation:

- 1 Volume control, Stock No. P-90978
- 1 7,000 ohm Resistor, Stock No. P-90979
- 1 Tip Jack Assembly, Stock No. P-1193

The volume control must be mounted in the same position as the original. The switch is operated by turning the volume control knob to the left as far as possible. The connections on the volume control are the same as on the original.

Removal of the license plate on the rear of the chassis will disclose a slot with small holes at each end. The tip jack assembly should be bolted to the chassis (inside), through the small holes. Bolt the license plate through the small holes, directly above its original position.

Locate the black wire under the chassis, leading from the secondary of the second intermediate transformer. This transformer is directly behind the gang condenser. Disconnect this wire where it is grounded on the chassis and solder the end to the tip jack nearest the center of the back of the chassis. If it does not reach to the tip jack, splice an extra length of wire to it but make the lead as short as possible. Solder and tape the splice so it is firm and well insulated.

Ground the OPPOSITE tip jack on the chassis by soldering one end of a short length of wire on the jack and the opposite end on a lug placed under the nut on the bolt holding the nearest end of the tip jack assembly.

Solder one end of the 7,000 ohm resistor (R17, Fig. 2) to the cathode connection on the second detector tube socket.

Three wires, twisted together and long enough to reach from the switch on the volume-control (around the closed ends of the R.F. transformer shields), to the tip jacks are connected as shown in Fig. 2.

Wire No. 1 connects the grounded tip jack and the switch terminal farthest from the center of the volume control.

Wire No. 2 connects the jack on which the black lead from the I.F. transformer is connected, and the raised switch terminal near the center.

Wire No. 3 connects one end of the 7,000 ohm resistor and the remaining open lug on the switch. When the receiver volume control is turned to the left as far as possible, the S.P.D.T. switch is thrown and opens the circuit from "A" (Fig. 2) to "B" and closes the circuit from "B" to "C."

This action places the pickup in the circuit and connects the 7,000 ohm resistor so that a proper grid bias is obtained for phonograph reproduction.

If a transformer is used, a ratio of 4 to 1 will prove satisfactory. The secondary is connected to the tip jacks and the primary to the pickup cords.

Reversing the pickup leads will determine the correct position in which they should be left. Some pickups have one side grounded and that side should be connected to the grounded pickup jack in the receiver.

If the pickup is disconnected, a wire "jumper" MUST be placed across the tip jacks before broadcast signals may be received. The receiver must never be turned on for even a moment without the jumper in place. A jumper will close the circuit between "A" and "B." This grounds the circuit, thereby placing the proper grid bias on the detector tube, even though the volume control may be thrown to the phonograph position. This jumper may be a piece of solid wire, the ends of which are bent at right angles and plugged into the tip jacks.

GULBRANSEN CO.

MODEL 20 Series.
Schematic
Early-Late

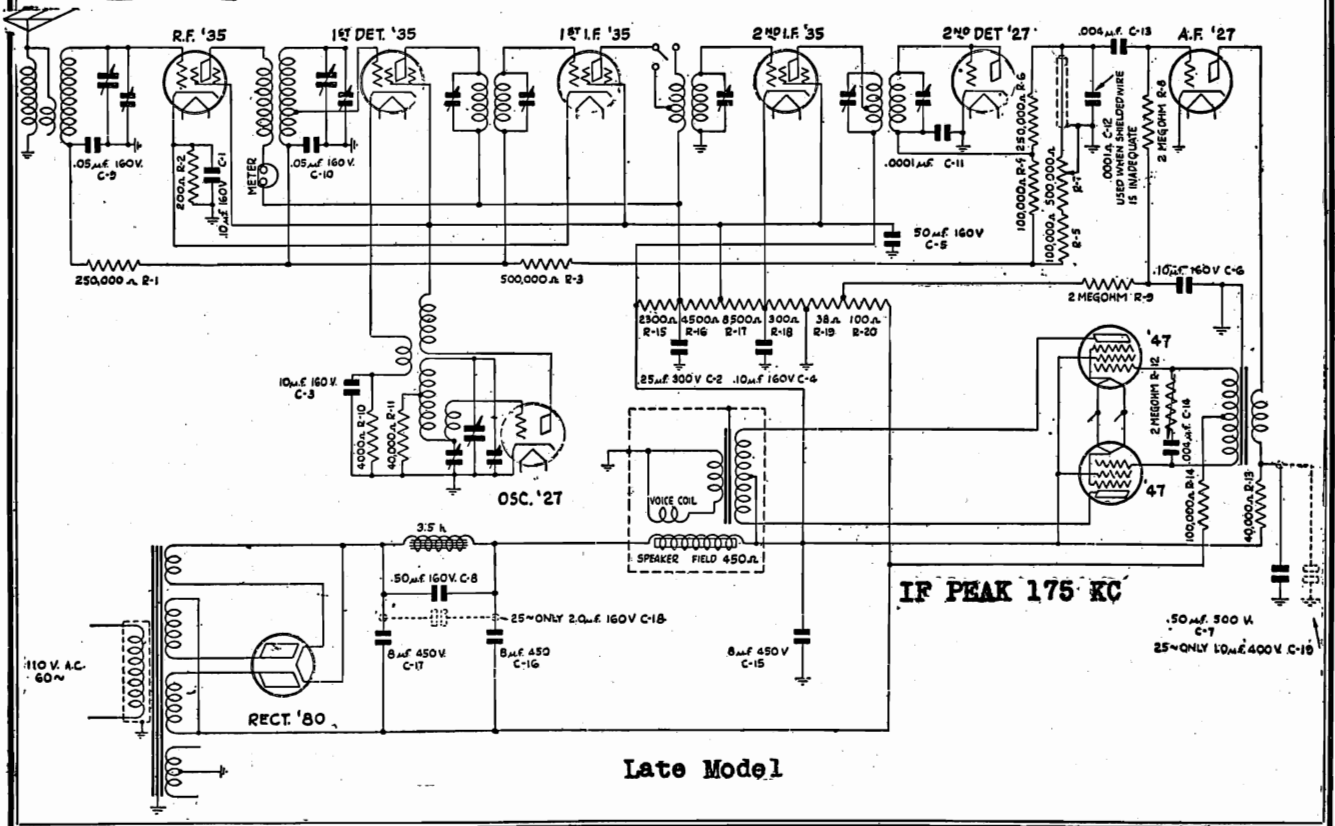
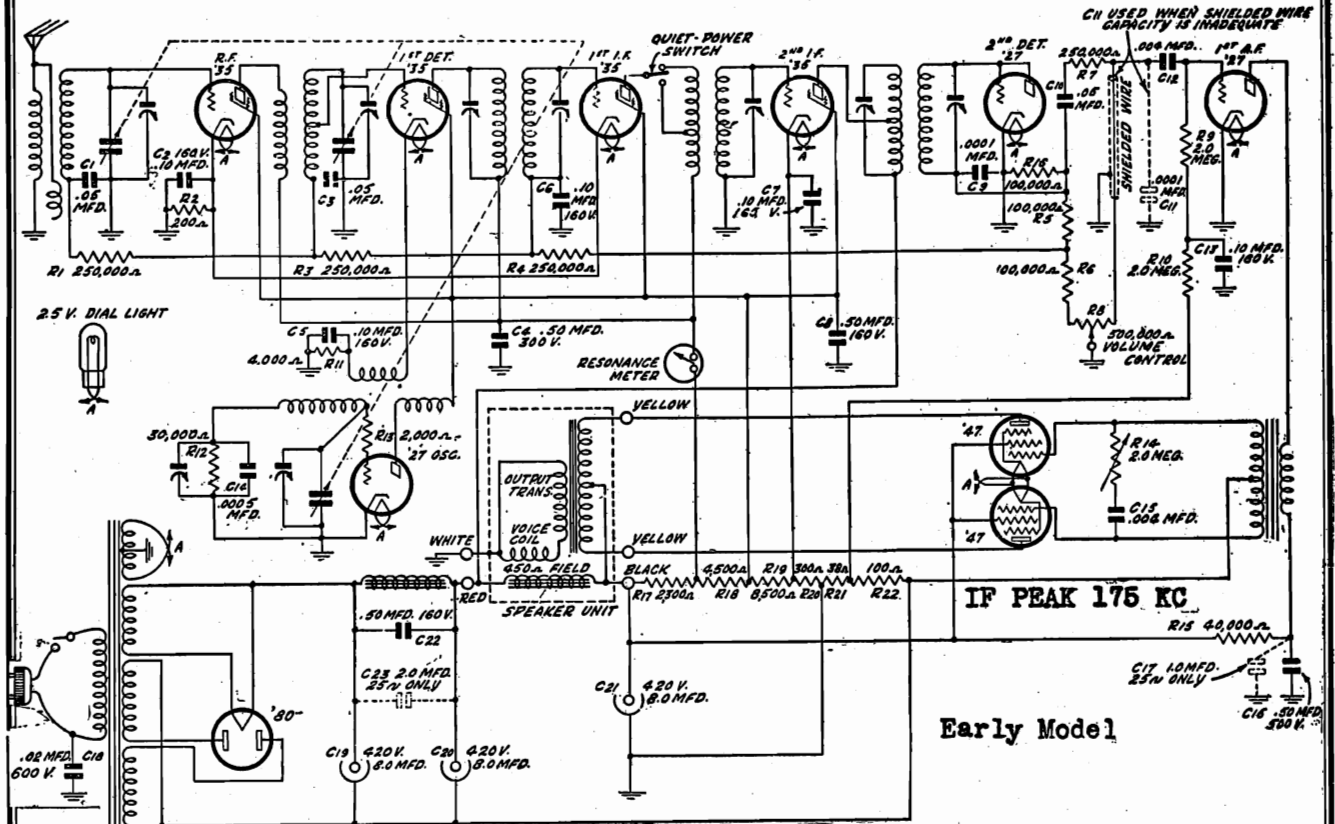

MODEL 20 Series

Voltage
Alignment

GULBRANSEN CO.

ALIGNMENT

A thorough check of the receiver should be made before any attempt is made to re-align any circuits. Examine the antenna and ground connections. Test all the tubes and check all voltages to determine if the failure of the receiver to operate properly is not due to some fault other than mis-alignment. A superheterodyne receiver must be accurately aligned to be selective and sensitive. This receiver has been accurately aligned at the factory and, due to the mechanical design of the gang and adjustable condensers, will not lose its alignment unless damaged by abuse or accident.

A modulated test oscillator and an output meter **MUST** be used when aligning this receiver to insure accurate alignment. It is important that the oscillator deliver a signal at exactly 175 K.C. in addition to frequencies in the broadcast band.

The adjustable condensers which tune the secondaries of the I. F. transformers are located under the hole in top of the shield where the grid lead to the tube is brought out. The condensers which tune the primaries of the first and third I. F. transformers are located under the small hole opposite. The capacity of each condenser is varied by rotating the small adjustment screw under the hole.

A trimmer condenser is mounted over each condenser in the gang and is adjusted by turning the screw located under the hole in top of the gang shield. The shield should not be removed.

The oscillator 600 K C. tracking condenser is located under the hole in the oscillator unit shield.

Make each adjustment in the order given below or the receiver may be thrown further out of alignment and it will then be a difficult task to align it properly.

The receiver and test oscillator must be well grounded and the output kept within the range of the output meter at all times. All shields must be in place when making the adjustments.

Tube	Circuit	Meter Scale	90 V.	100 V.	110 V.	120 V.
R.F. '35	Screen	0—100	67.	75.	82.	90.
	Grid	0—250	136.	151.	166.	181.
1st Det '35	Screen	0—100	63	70.	77.	84.
	Grid	0—250	132.	147.	163.	179.
Oscillator '27	Plate	0—100	70	77	85.	92.
1st I.F. '35	Screen	0—100	67	75	82.	90.
	Grid	0—250	136.	151.	166.	181.
2nd I.F. '35	Screen	0—100	65.	72.	79.	86.
	Grid	0—1000	227.	252.	277.	303.
1st A.F. '27	Plate	0-100	87.	95.	104.	115.
2nd A.F. '47	Grid	0-25	12.7	14.	15.4	17.
	Accelerating	0-1000	192	208.	235.	252.
80 Rect.	Grid	0-1000	180	200.	220.	240.
	Plate	0-100	89. M.A.	98. M.A.	108. M.A.	118. M.A.
(See below)	(Both Plates) Plate to Plate voltage	0-1000	547	568.	690.	712.

GULBRANSEN CO.

MODEL 20 Series
Parts List
Socket-Data

RESISTORS

Part No.	Name	List Price	Part No.	Key No.	Resistance	Type	List Price
P-20408	Tube Shield Base	.10	P-90954-B	R1	250,000	Carbon	.25
P-1193	Laminated Phono Jack	.15	P-90935-A	R2	200	Carbon	.25
P-1336	Control Knob	.25	P-90938	R3	500,000	Carbon	.25
P-1092	Grid Clip Assembly	.10	P-90912-A	R4	100,000	Carbon	.25
P-20365	Wire Clamp	.10	P-90912-A	R5	100,000	Carbon	.25
P-1273	Dial Light Bulb, 2.5 volts	.25	P-90954-B	R6	250,000	Carbon	.25
P-1011	S. P. D. T. Switch (Quiet-Power or Phono)	.70	P-90980	R7	0-500,000	Volume Control	1.35
P-1384	Resonance Meter	2.75	P-90923-A	R8	2 meg.	Carbon	.25
P-50534	Power Supply Choke	1.40	P-90923-A	R9	2 meg.	Carbon	.25
P-10180	Rubber Chassis Support (Large)	.10	P-90947	R10	4,000	Carbon	.20
P-10181	Rubber Chassis Support (Small)	.10	P-90916	R11	40,000	Carbon	.25
P-1146	Terminal Strip (Large)	.15	P-90986-B	R12	0-2 meg.	Tone Control	.95
P-1173	Terminal Strip (Small)	.10	P-90945	R13	40,000	Carbon	.30
P-20422	Chassis Mounting Stud	.10	P-90912-A	R14	100,000	Carbon	.25
P-1388	Dial Escutcheon Plate (Give Model number of set)	.60	P-91000	R15	2,300	Vitreous Enamel Resistor	1.80
P-20286	Resistor Spring Mtg. Bracket	.10		R16	4,500		
P-1054	On-Off Toggle Switch	.75		R17	8,500		
P-80889	3 Gang Condenser less drive for rubber pinion drive only	6.40		R18	.300		
				R19	.38		
			R20	100			

CONDENSERS

Part No.	Key No.	Capacity	Type	Voltage Rating	List Price	
P-80862	C9	.05	Tubular	160 V.	\$0.30	
P-80862	C10	.05	Tubular	160 V.	.30	
P-80865	C11	.0001	Molded		.20	
P-80865	C12	.0001	Molded		.20	
P-80863	C13	.004	Tubular		.25	
P-80863	C14	.004	Tubular		.25	
P-80901	C15	8.0	Electrolytic	450 V.	1.50	
P-80900	C16	8.0	Electrolytic	450 V.	1.60	
P-80900	C17	8.0	Electrolytic	450 V.	1.60	
*P-1128	Drive Bracket & Bearing Assembly	.15	C1	.1	160 V. White, Green Tr.	} Common Black Lead 3.20
			C2	.25	300 V. Blue	
			C3	.1	160 V. White, Green Tr.	
			C4	.1	160 V. White, Red Tr.	
			C5	.5	160 V. Brown	
			C6	.1	160 V. White	
			C7	.5	500 V. Red	
			C8	.5	160 V. Yellow. (2 Leads)	
*P-80879	Block	.20	C18	2.0	160 V. { 25 cy. only }	} 2.20
			C19	1.0	400 V. { 25 cy. only }	

*Asterisk refers to parts used on drum dial models.

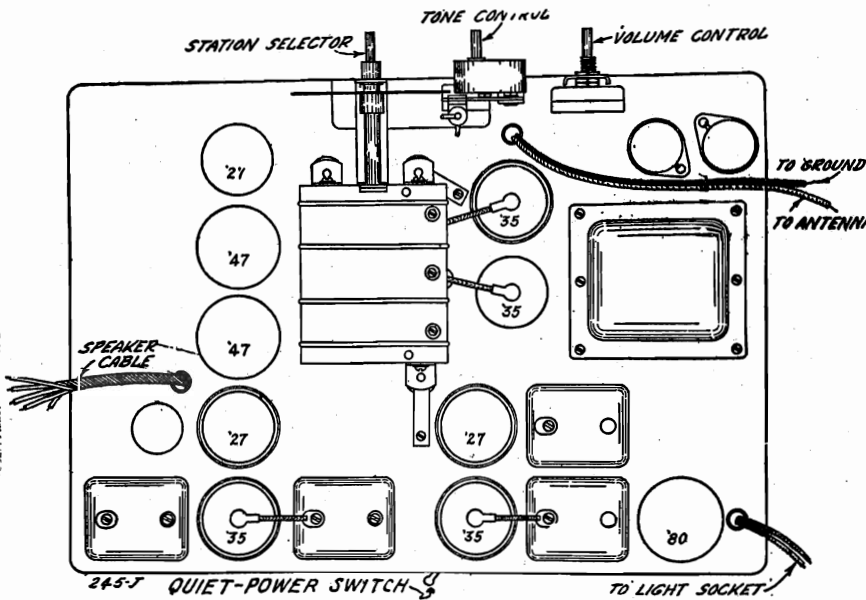

Key No.	Capacity	Lead Color
C22	.5 mfd.	Yellow
C16	.5 mfd.	Common Black
C4	.5 mfd.	Common Black
C8	.5 mfd.	Common Black
C5	.1 mfd.	Common Black
C2	.1 mfd.	White, Green Tr.
C7	.1 mfd.	White, Green Tr.
C6	.1 mfd.	White, Red Tr.
C13	.1 mfd.	Black, White Tr.
		White

Referring to sections C6 and C13 in the above list, it will be noted that these have two leads each with the same color code. This was changed in a later model to one lead each, the other lead of each section being connected to the common black lead.

At a later date, two further changes in this condenser block were made. Section C6 which bypassed the grid return of the first I.F. tube to ground was discontinued and section C4 was changed to .25 mfd. These changes bring the block up to date.

The key numbers (C5, etc.) in the above description of the condenser block refer to the key numbers as shown in the schematic circuit diagram of the early chassis, the key numbers of the condenser block as shown in the parts list in the foregoing service manual conform with the key numbers as shown in the schematic of the present chassis, Fig. 1. As explained at the beginning of this supplement, the two sets of key numbers do not coincide.

MODEL 23
Chassis

GULBRANSEN CO.

SERIES 23 SUPERHETERODYNE

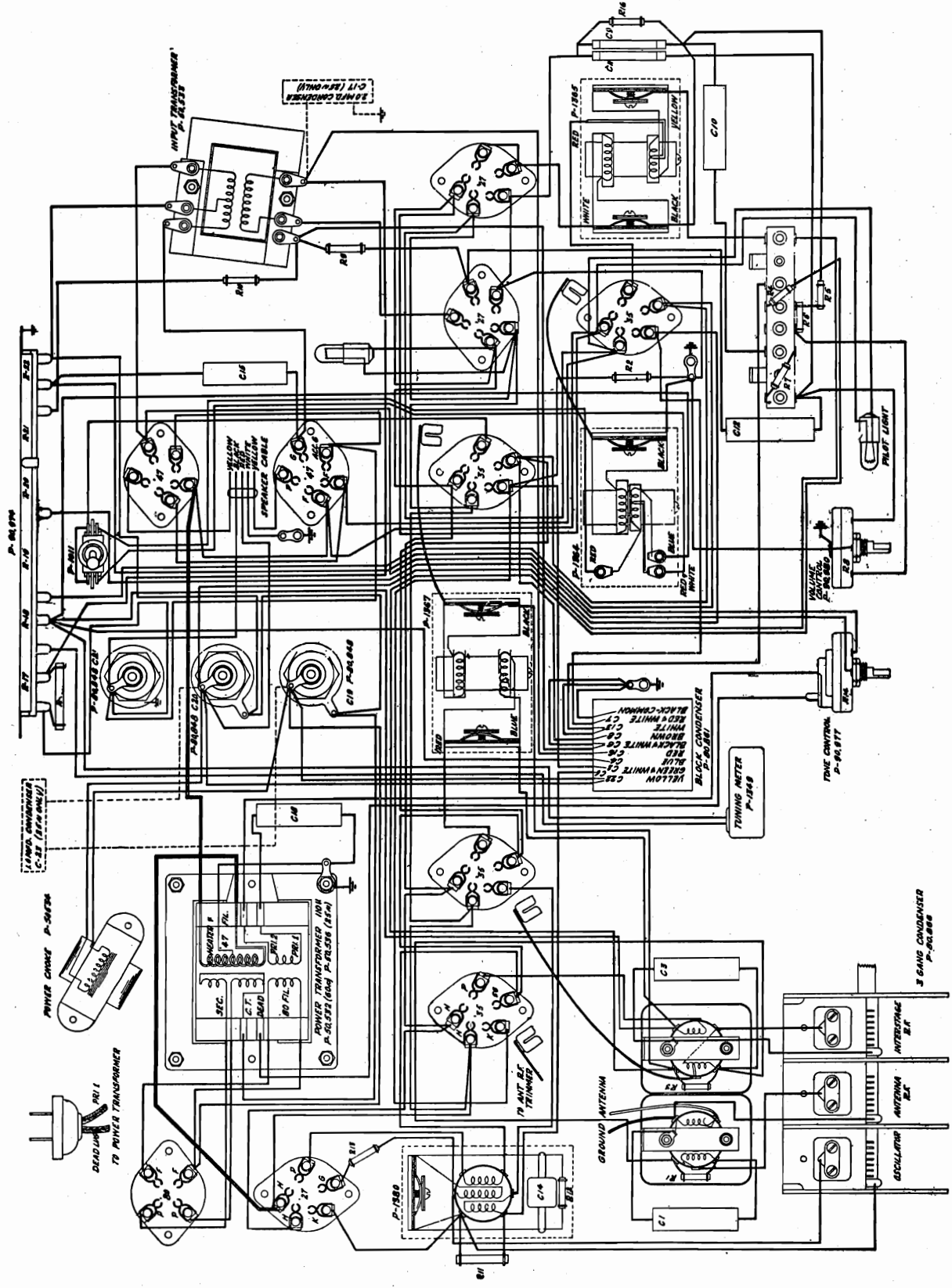

GULBRANSEN CO.

MODEL 23
Schematic

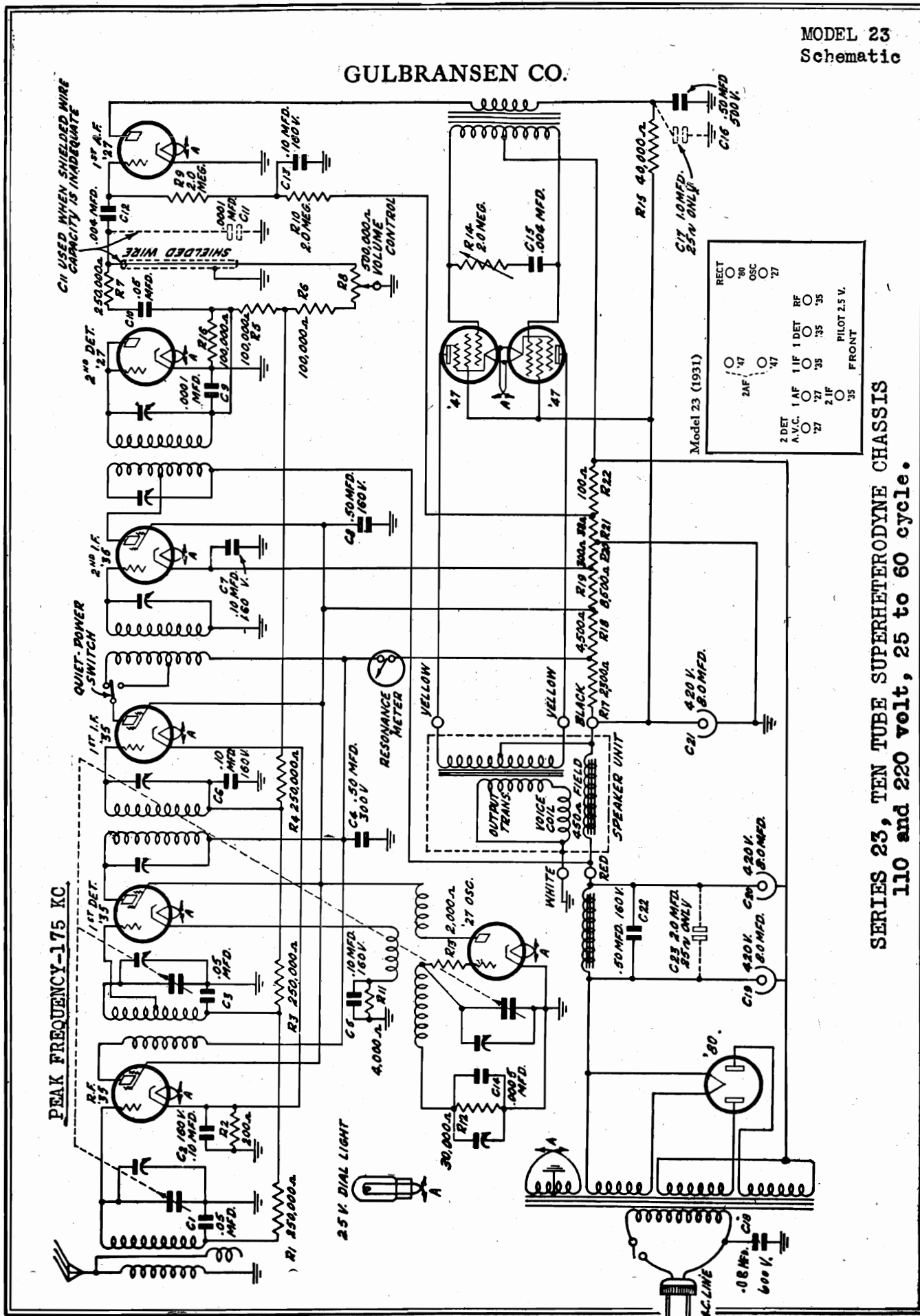

PEAK FREQUENCY-175 KC.

C11 USED WHEN SHIELDED WIRE CAPACITY IS INADEQUATE

QUIET-POWER SWITCH

25 V. DIAL LIGHT

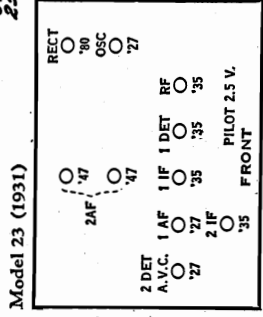

SERIES 23, TEN TUBE SUPERHETERODYNE CHASSIS
110 and 220 volt, 25 to 60 cycle.

MODEL 23
Parts List
Phono Data

GULBRANSEN CO.

SERIES 23 SUPERHETERODYNE

PHONO PICKUP INSTALLATION

The following parts must be supplied from the factory to make the installation:

- 1 S. P. D. T. Switch, Stock No. P-1011
- 1 Tip Jack Assembly, Stock No. P-1193.

Removal of the license plate on the rear of the chassis will disclose a slot with small holes at each end. The tip jack assembly should be bolted, inside, through the small holes.

Drill a 31/64" hole one inch from the tip jack nearest the center of the rear of the chassis and place the barrel of the switch through the hole with the body of the switch in a horizontal position.

The terminal strip mounted in the left front corner of the base has the resistor, R7, (Red body, green end, yellow dot), connected to the first and second terminals on the end of the strip nearest the center of the chassis. One end of the .05 mfd. condenser, C10, is also connected to the second terminal. See Fig. 4.

Disconnect the resistor, R7, at the second terminal of the strip. Splice a piece of wire to the disconnected end of the resistor and connect the other end of the wire to two terminals, one on each end and on the same side of the switch.

Connect another wire to the terminal where the resistor was disconnected and connect the other end to one of the two open terminals on the switch.

The remaining open terminal on the switch is then connected to the tip jack nearest the corner of the chassis base.

Ground the opposite tip jack on the grounded terminal of the candohm resistor.

Make all wires and connections short, firm, and well insulated.

When the switch is thrown so that the circuit from "A" to "B," is open and the circuit from "B" to "C" is closed, the pickup is then properly connected for phonograph reproduction. The switch is thrown in the opposite direction for the reception of broadcast signals.

Reversing the pickup leads will determine the correct position in which they should be left. Some pickups have one side grounded and that side should be connected to the grounded pickup jack in the receiver.

C6 and C13 contained in the block have one side grounded and the balance of the condensers in the block, with the exception of C22, have a common lead which is also grounded. C22 tunes the choke in the power supply. C17 and C25 are used in the 25 cycle chassis only, as shown in the schematic diagram.

RESISTORS

Part No.	Key No.	Resistance	Type	Base	End	Dot
P-90954-B	R1	250,000	Carbon	Red	Green	Yellow
P-90935-A	R2	200	Carbon	Red	Black	Brown
P-90954-B	R3	250,000	Carbon	Red	Green	Yellow
P-90954-B	R4	250,000	Carbon	Red	Green	Yellow
P-90912-A	R5	100,000	Carbon	Brown	Black	Yellow
P-90912-A	R6	100,000	Carbon	Brown	Black	Yellow
P-90954-B	R7	250,000	Carbon	Red	Green	Yellow
P-90980	R8	500,000	Volume Control			
P-90923-A	R9	2 meg.	Carbon	Red	Black	Green
P-90923-A	R10	2 meg.	Carbon	Red	Black	Green
P-90947	R11	4,000	Carbon	Yellow	Black	Red
P-90956-A	R12	30,000	Carbon	Orange	Black	Orange
P-90906-C	R13	2,000	Carbon	Red	Black	Red
P-90977-B	R14	2 meg.	Tone Control			
P-90945	R15	40,000	Carbon	Yellow	Black	Orange
P-90912-A	R16	100,000	Carbon	Brown	Black	Yellow

Part No.	Key No.	Capacity	Type	Voltage Rating	Identification
P-90974-C	R17	2,300	Candohm		
	R18	4,500			
	R19	8,500			
	R20	300			
	R21	38			
	R22	100			

CONDENSERS

Part No.	Key No.	Capacity	Type	Voltage Rating	Identification
P-80862	C1	.05	Tubular		Red - Orange
P-80862	C3	.05	Tubular		Red - Orange
P-80865	C9	.0001	Moulded		Red - Orange
P-80862	C10	.05	Tubular		Red - Orange
P-80865	C11	.0001	Moulded		Red - Orange
P-80863	C12	.004	Tubular		Tan - Orange
P-80867	C14	.0005	Moulded		Red - Orange - Blue
P-80863	C15	.004	Tubular		Tan - Orange
P-80869	C17	1.0			
P-80868	C18	.02	Tubular		Green - Orange
P-80848-A	C19	8.0	Electrolytic	420 V.	Orange
P-80848-A	C20	8.0	Electrolytic	420 V.	Orange
P-80848-A	C21	8.0	Electrolytic	420 V.	Orange
P-80870	C23	2.0			

P-80861-B (Block)	C2	1	Block	160 V.	White, Green Tr.
	C4	.5	Block	300 V.	Blue
	C5	.1	Block	160 V.	White, Green Tr.
	C6	.1	Block	160 V.	Black, White Tr.
	C7	.1	Block	600 V.	White, Red Tr.
	C8	.5	Block	160 V.	Brown
	C13	.1	Block	160 V.	White
	C16	.5	Block	500 V.	Red
	C22	.5	Block	160 V.	Yellow (2)
P-80866	Complete Gang Assembly with Shield (no dial assembly)				

MODEL 23
Voltage
Phono Data

GULBRANSEN CO.

SERIES 23 SUPERHETERODYNE

POWER TRANSFORMER

Fig. 4 shows the 110 volt power transformer connections. One side of the 110 volt A. C. line is connected to the terminal marked "Pri. 1" and the other side to the open terminal, on the opposite side of the winding, which is in turn connected to one terminal of the switch on the receiver. The switch completes the circuit to the "Pri. 2" terminal.

The 25 cycle transformer is especially designed to operate on 110 volt, 25 cycle current, but may also be operated on any 110 v. A. C. supply having a higher frequency, after the condensers C17 and C23 have been disconnected.

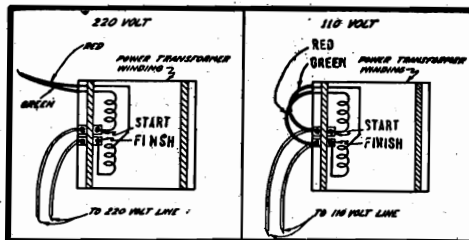

Receivers having a 220 volt, 40 to 60 cycle power transformer may also be operated on 110 volt, 40 to 60 cycle current when connections on the primary of the transformer have been changed.

The red and green wires shown in the 220 volt sketch, must be disconnected and then connected as shown in the 110 volt sketch. No other changes are necessary.

Tube	Circuit	Meter Scale	110 V.
R.F. '35	Screen Grid Plate	0-100 0-250	82. 166.
1st Det. '35	Screen Grid Plate	0-100 0-250	77. 163.
Oscillator '27	Plate	0-100	85.
1st I.F. '35	Screen Grid Plate	0-100 0-250	82. 166.
2nd I.F. '35	Screen Grid Plate	0-100 0-1000	79. 277.
1st A.F. '27	Plate	0-100	104.
2nd A.F. '47	Grid Accelerating Grid Plate	0-25 0-1000 0-1000	15.4 235. 220.
'80 Rect.	Current (Both Plates) Plate to Plate voltage	0-100 0-1000	108. M.A. 690.

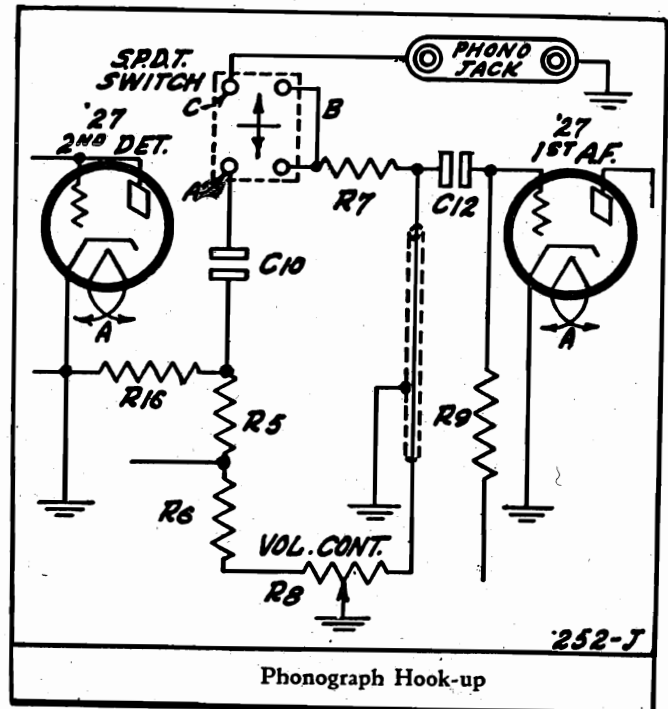

The '80 rectifier plate voltages shown are the totals of both plates, measured from each plate to center tap of high voltage secondary

All voltages taken with a 1,000 ohm per volt voltmeter on the scale in the column headed "Meter Scale." Turn the volume all the way on, connect the antenna and ground leads together and turn the gang condenser plates all the way out. CHECK THE LINE VOLTAGE.

The measurement of grid bias voltages (except on the 47 pentodes) is not recommended, as this causes an abnormal rise in plate current which is injurious to the tube. Further, the measurement of actual grid bias voltages is impossible due to the high resistance in the grid circuits. When the receiver does not function properly and the trouble is apparently due to improper grid bias on any tube or tubes, the cause of the trouble may be determined by applying the proper continuity tests.

CAUTION: IN ORDER THAT THE EFFICIENCY OF EACH TUBE MAY BE COMPARED WITH THAT OF OTHER TUBES OF THE SAME TYPE, THEY MUST NOT BE TESTED IN THE SOCKET IN WHICH THEY ARE USED. TEST ALL '35 TUBES IN THE SECOND I. F. SOCKET AND TEST THE '27 TUBES IN THE FIRST A. F. SOCKET. TAKE THE VOLTAGE READINGS AT THE SOCKET IN WHICH THE TUBE IS USED.

MODEL 23

Data

GULBRANSEN CO.

**SERIES 23
SUPERHETERODYNE**

REVISED MODEL

A green paint mark on the left rear corner of a chassis indicates the following changes:

(1) Combination tone control and "On-Off" switch replaced by two separate units. The tone control is mounted and connected as previously but "On-Off" switch is on side of cabinet.

(2) Intermediate transformers assembled together with their adjustable tuning condensers in a round shield. Condensers are adjusted by inserting screwdriver through the holes provided underneath base, directly below transformer assembly. Early models are adjusted through hole in top of (rectangular) shield

(3) The oscillator coil, its shield, and the 600 K.C. tracking condenser are all mounted separately on the base. The tracking condenser adjustment screw will be found near the left rear corner of the oscillator coil shield. The .0005 mfd. condenser (C14) is not used and the 30,000 ohm resistor (R12) is replaced by a 40,000 ohm resistor mounted between a coil lug and the tracking condenser. The revised oscillator circuit is shown herewith:

The parts affected by the change, are listed below with corresponding parts numbers:

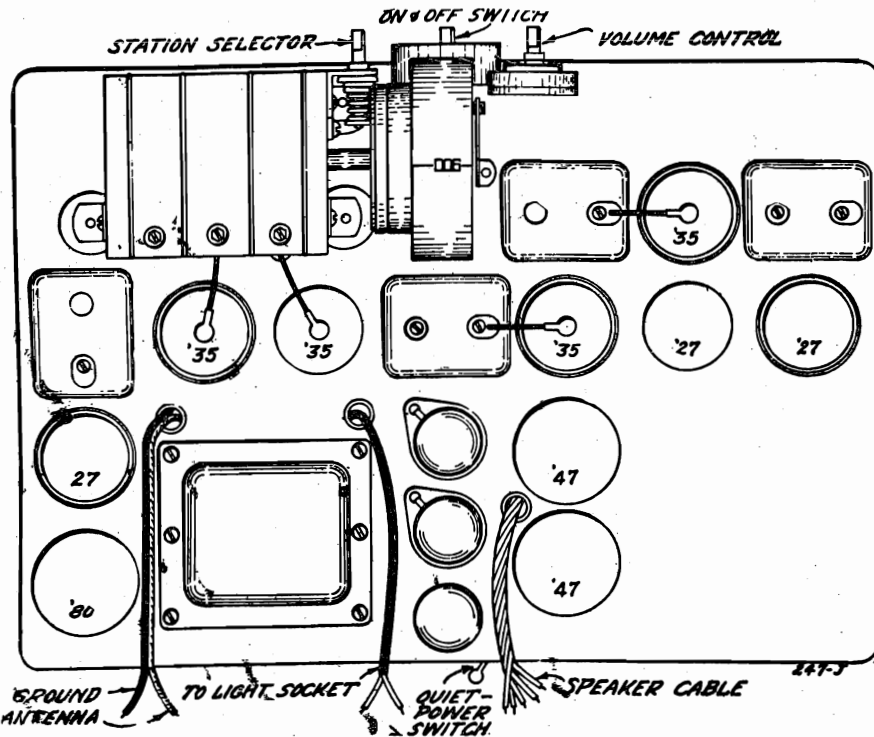

TOP VIEW OF EARLY MODEL RECEIVER

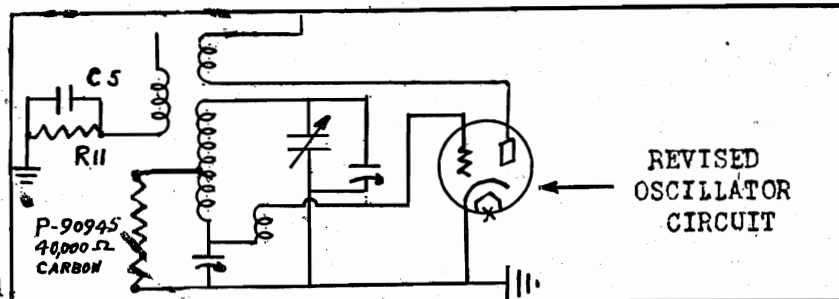

OLD NUMBER	NEW NUMBER
Tone Control & "On-Off" Switch-----	"On-Off" Switch-----P-1054
P-90977	Tone Control-----P-90986-A
1st L.F. Transformer Assembly-----	1st I.F. Assembly-----P-1424
P-1367	2nd I.F. Assembly-----P-1425
2nd I.F. Transformer Assembly-----	3rd I.F. Assembly-----P-1426
P-1364	Oscillator Coil-----P-1400
3rd I.F. Transformer Assembly-----	Coil Shield-----P-40412
P-1365	600 K.C. Tracking Conden.--P-1385-A
Oscillator Unit	40,000 Ohm Carbon Resistor-P-90945
P-1366	

MODEL 13
 MODEL 23
 Alignment

GULBRANSEN CO. ALIGNMENT

A thorough check of the receiver should be made before any attempt is made to re-align any circuits. Examine the antenna and ground connections. Test all the tubes and check all voltages to determine if the failure of the receiver to operate properly is not due to some fault other than mis-alignment. A superheterodyne receiver must be accurately aligned to be selective and sensitive. This receiver has been accurately aligned at the factory and, due to the mechanical design of the gang and adjustable condensers, will not lose its alignment unless damaged by abuse or accident.

A modulated test oscillator and an output meter **MUST** be used when aligning this receiver to insure accurate alignment. It is important that the oscillator deliver a signal at exactly 175 K.C. in addition to frequencies in the broadcast band.

The adjustable condensers which tune the secondaries of the intermediate transformers are located under the hole in top of the shield where the grid lead to the tube is brought out. The condensers which tune the primaries are located under the small hole opposite. The capacity of each condenser is varied by rotating the small adjustment screw under the hole.

Make each adjustment in the order given below or the receiver may be thrown further out of alignment and it will then be a difficult task to align it properly.

The receiver and test oscillator must be well grounded and the output kept within the range of the output meter at all times.

All shields must be in place when making the adjustments.

INTERMEDIATE CIRCUITS

Tune the test oscillator to exactly 175 K.C. and connect its output to the grid of the first detector tube after removing the clip on the lead from the gang condenser.

Adjust the primary and secondary of the first intermediate transformer for greatest volume.

Follow the same procedure on the second intermediate transformer and then turn the receiver off.

Disconnect one end of the speaker voice coil and connect the output meter across the secondary of the speaker coupling transformer. Short the oscillator tuning condenser (in the gang) by grounding the stator plates with a screw driver.

Turn the receiver on and adjust the output until the output meter shows a small or medium scale deflection.

Adjust the primary of the first intermediate transformer for the greatest deflection on the output meter.

Adjust the secondary in the same manner.

Follow the same procedure on the second intermediate transformer and then check the settings of all condensers to make certain the maximum output has been obtained.

When the above instructions have been followed, remove the test oscillator coupling and replace the grid lead on the first detector, and also remove the screw driver shorting the oscillator tuning condenser.

GANG CONDENSERS

Couple the test oscillator output to the antenna, (white wire), on the receiver.

Tune the oscillator to 1400 K.C. and carefully tune the receiver to the signal.

A trimmer condenser is mounted over each condenser in the gang and is adjusted by turning the screw located under the hole in top of the gang shield. The shield should not be removed. Adjust each trimmer condenser for maximum deflection on the output meter.

OSCILLATOR

Tune the test oscillator to 600 K.C. and tune the receiver to the signal. Then after turning the receiver off, disconnect the output meter and replace the voice coil lead which was disconnected.

Turn the receiver on and rotate the adjusting screw on the 600 K.C. tracking condenser under the hole in top of the oscillator transformer shield. Rock the gang condenser back and forth across the signal at the same time and listen closely until the maximum volume is obtained. The tracking condenser is then properly adjusted and remains fixed thereafter.

The receiver should be accurately aligned if the above instructions have been followed and no further adjustments need be made.

SERIES 13 AND SERIES 23 SUPERHETERODYNE

GULBRANSEN CO.

MODEL 362

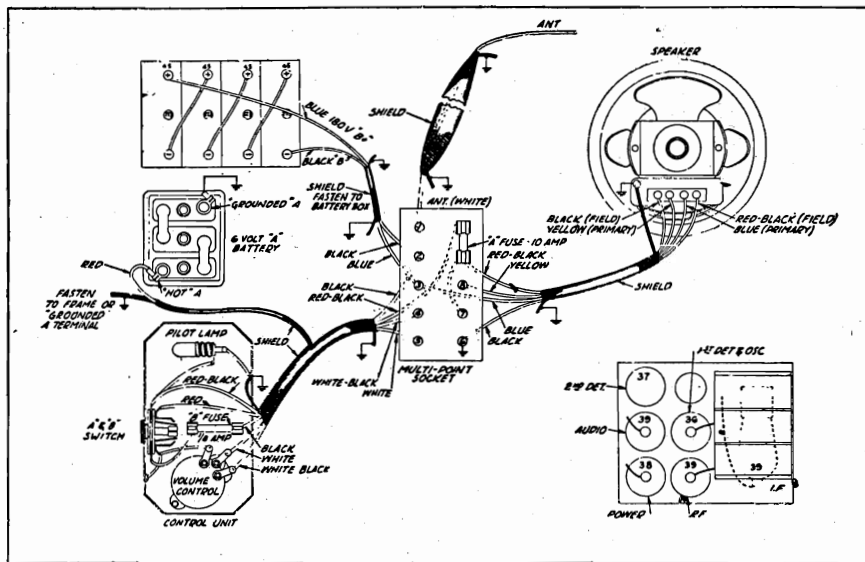
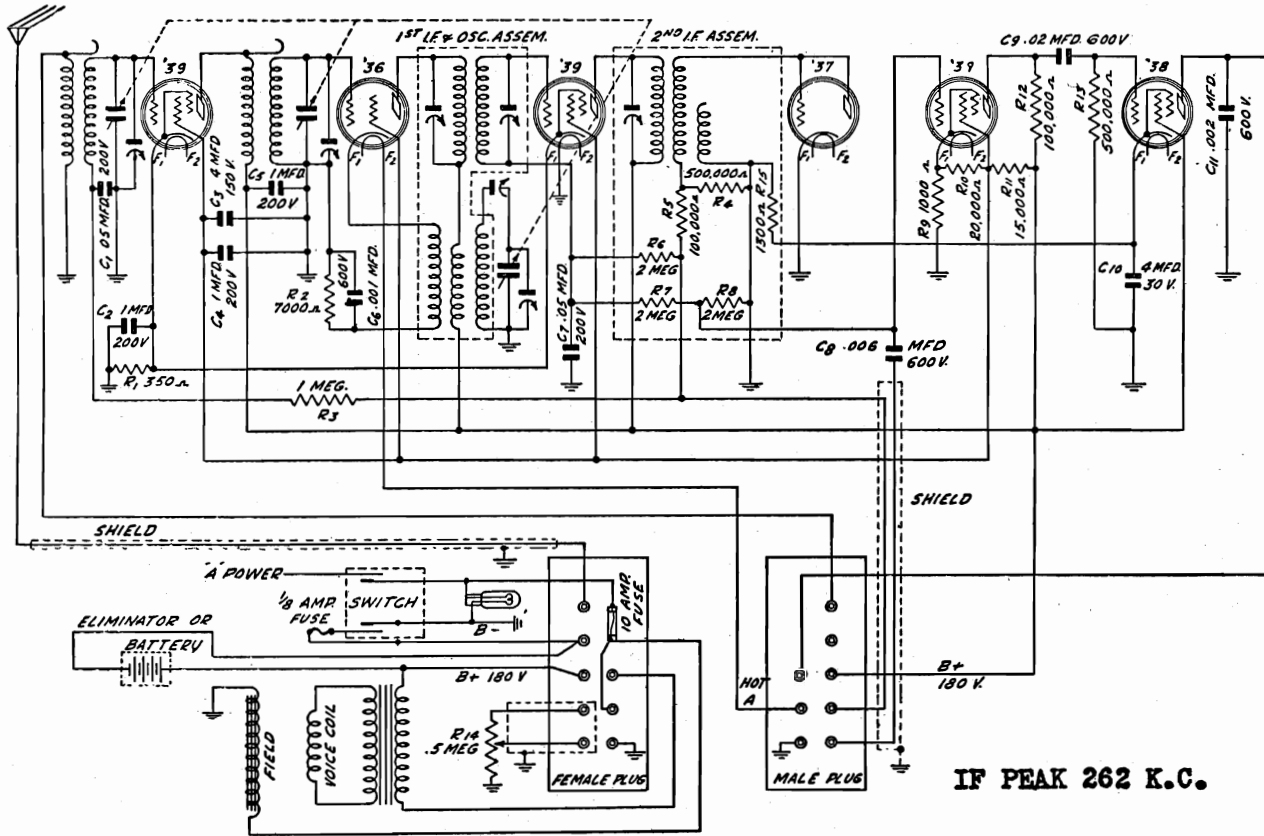

VOLTAGE DATA

Tube	Plate	Screen	Grid	Plate MA.
R-F.	177	80	3	3.6
1st Det.	173	76	7*	.9*
I-F.	177	80	3	3.6
2nd Det.	0	0	0	0
1st A-F.	54	77	6	1.2
Output	159	165	15.5	10.0

* Will vary with dial setting.

CHARLES HOODWIN CO. MODEL Aero Auto Radio
MODEL Aero 1932 Converter

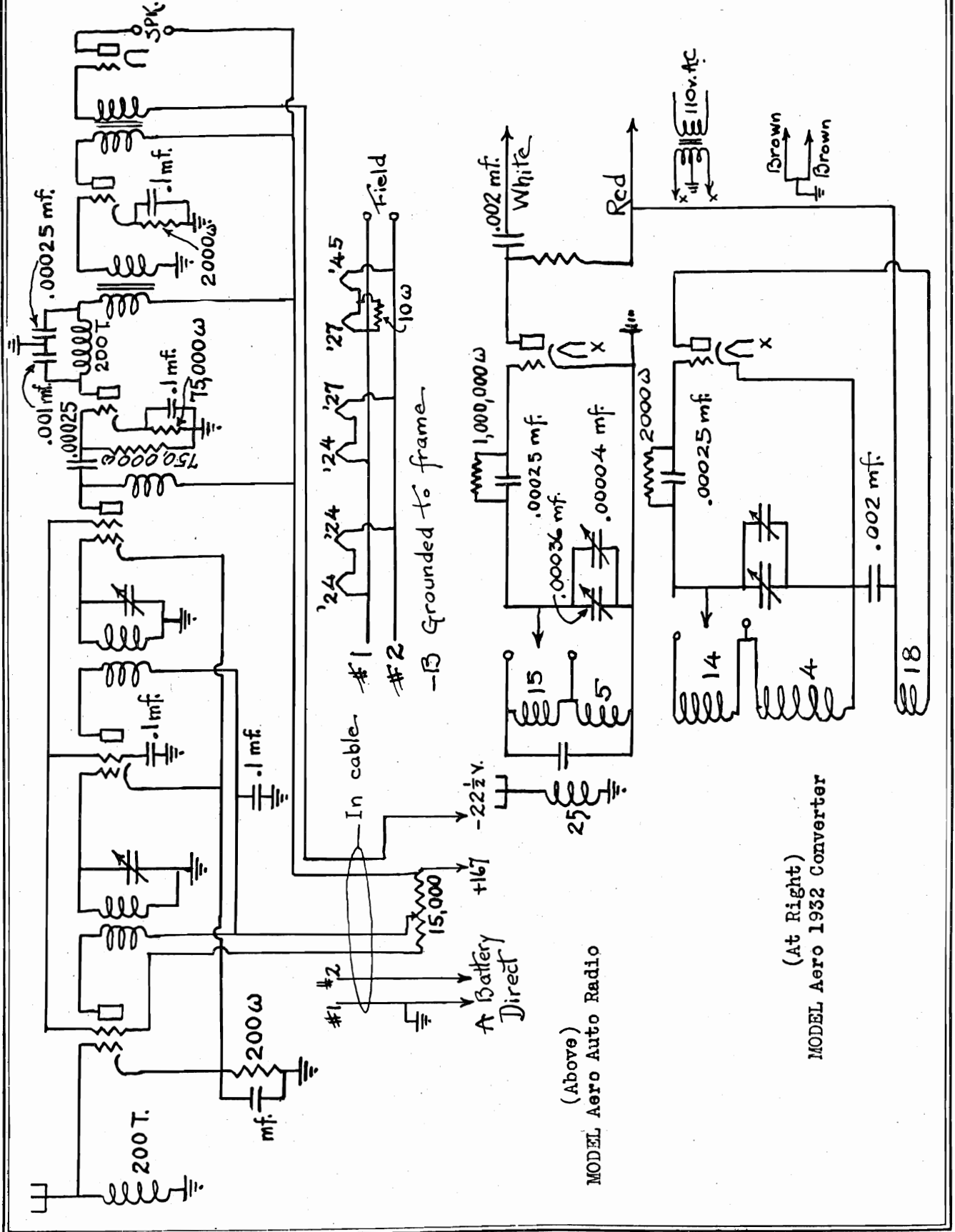

(Above)
MODEL Aero Auto Radio

(At Right)
MODEL Aero 1932 Converter

MODEL Tiffany Tone 101, 110
Alignment Data

HERBERT H. HORN

VOLTAGE TABLE
No Signal Input To Receiver

No.	Type	Function	Plate	Screen	Cathode	Heater
1	335	RF Amp	187	80	2.8*	2.1
2	335	Trans	187	80	2.8*	2.1
3	327	Osc.	80	-	4.2*	2.1
4	335	IF Amp	187	80	2.8*	2.1
5	327	Det.	-	-	-	2.1
6	327	1st AF	30*	-	4.9*	2.1
7	227	2nd AF	115	-	7.2*	2.1
8	347	Output	210	205	13.1*	2.3
9	347	Output	210	205	13.1*	2.3
10	280	Rect.				4.8

* Voltmeter resistance 50,000 ohms. All other voltages measured with 250,000 ohm voltmeter. Chassis is negative for all readings.

IF TRANSFORMER ADJUSTMENT

There are four i-f transformers. Both the grid and plate circuits of each must be tuned sharply to 175 kc. The condenser adjusting screws are accessible from the underside of the chassis; there being two slotted screws protruding through the insulated base of each transformer.

LINE UP OF GANG CONDENSERS

The four sections of the gang condenser function as follows: The first section, looking at the rear of the chassis tunes the selector stage. The second section tunes the grid circuit of the r-f amplifier. The third section tunes the grid circuit of the translator tube and the fourth section tunes the oscillator. The fourth section is that nearest the front of the chassis. The first three must track together at signal frequency, which is the desired signal frequency. The oscillator section on the other hand must track 175 kc higher than the signal frequency.

THE SHORT WAVE TUNER

The short wave tuner consists fundamentally of two tuned circuits and two tubes, one of which is a 224 operating at short wave signal frequency as a first detector and the other tube is a 227 oscillator tuned to 550 kc higher than the desired short wave signal frequency. The resultant beat of 550 kc is fed into the antenna post of the broadcast part of the complete receiver chassis, which operates as an 550 kc intermediate frequency amplifier during short wave reception. The dial of the broadcast receiver must be set to 550 kc during short wave reception.

To balance: Set band selector switch on position C - set dials on about 10. The front section of the two gang condenser tunes the detector stage to signal frequency; the back section tunes the oscillator coils to a frequency 550 kc greater than signal frequency. If the small variable condenser, which is paralleled with the detector condenser, will not resonate its circuit within its capacity range, it will be necessary to change the trimmer located on the oscillator section of the main tuning condenser. This may be done by tuning in a signal and rotating the variable trimmer to maximum resonance; if this point is reached with the balancing condenser plates at maximum capacity, it will be necessary to reduce the oscillator trimmer capacity, and if the resonance point is approached with the balancing condenser at minimum capacity, it will be necessary to add capacity to the oscillator trimmer. This should be regulated so the balancing condenser peaks with the plates about half way out, with the short wave tuning dial set at 50.

The approximate setting of the oscillator trimmer may be obtained by turning the adjusting screw down tight and then relasing it two full turns.

MODEL 35,40

(H)

Alignment Data.

HOWARD RADIO CO.

MODEL "H"

ADJUSTMENTS The 175 kc. oscillator must be accurately tuned to 175 kc. and only 175 kc. If this precaution is not observed it will be impossible to align the oscillator to the rest of the set and the set will not operate correctly as the oscillator is designed for exact 175 kc. operation.

The second intermediate frequency amplifier transformer shield can is removed and one side of the small variator condenser is disconnected from the primary coil. This coil is connected so that it still is in the plate circuit of the tube but the tuning condenser is not connected in the circuit. Now remove the grid cap from the intermediate amplifier tube and connect a 3 megohm resistor from the control grid to ground. Now connect the output from the 175 kc. oscillator to the grid of the intermediate frequency amplifier tube and tune the secondary for maximum deflection of the output meter. (Low voltage alternating current meter, 0 to 3 volts, connected across the voice coil of speaker). Now remove the shield can and connect the small tuning condenser that was previously removed back across the primary coil. With the 175 kc. oscillator connected the same as before, tune the primary for a maximum deflection of the output meter. (Caution: Do not under any circumstances try to retune the secondary after having tuned the primary. **This is important.**) After having tuned this stage proceed to the next intermediate frequency:

(b) Replace the grid cap on the intermediate frequency amplifier and proceed to the first detector tube. Remove this tube cap and connect the 175 kc. oscillator as before, being sure to connect the 3 megohm resistor from control grid to ground. Now proceed to tune the intermediate frequency transformer by tuning the secondary first for maximum deflection of the output meter and then tuning the primary for maximum deflection. Tuning this transformer must be done very carefully as the selectivity of the whole receiver depends entirely on the tuning of this transformer.

(c) To line up the radio frequency amplifier and detector stages, remove the oscillator tube and the second detector tube. Unsolder the connection on the plate terminal of first detector tube socket and solder a wire from this terminal to the plate terminal of the second detector tube socket. Now set the Test Oscillator (R. F. Generator) which tunes over the broadcast frequency range to 1400 kcs. Connect the output of this oscillator to the aerial and ground wires of the receiver. Now make sure that when the tuning condensers are all in maximum capacity that the pointer on the escutcheon lines up with the line just beyond the 550 kc. dial mark and then turn the dial until the escutcheon pointer lines up with the 1400 kc. line on the dial. The tuning condenser trimmers should now be adjusted until a maximum deflection is shown by the output meter. Now set the oscillator to 1000 kcs. Turn the dial to 1000 kcs. and then secure maximum deflection on the output meter by moving the serrated plates of the variable condenser in or out as the case may be. Repeat the same procedure at 600 kcs. as was used at 1000 kcs. (Do not touch the trimmer condensers after having once set them at 1400 kcs.). Unsolder the wire connecting the first detector plate terminal to the second detector plate terminal. Resolder the wire that was originally unsoldered from the first detector plate terminal. Now replace the oscillator and second detector tubes.

(d) To line up the oscillator tune the set to 1400 kcs. and adjust the oscillator tuning condenser trimmer (the last hole of the three holes in a line on the top of the tuning condenser housing) as viewed from the front of the set, (see Fig. 1) until a maximum reading is secured on the output meter. Adjust the Test Oscillator to 600 kcs. and tune the receiver to 600 kcs. Now adjust the oscillator series condenser trimmer (the hex. nut in the hole to the left of the oscillator tuning condenser trimmer hole) until a maximum deflection is secured on the output meter. Now reset the Test Oscillator to 1400 kcs. and retune the set to 1400 kcs. and make adjustments if any are necessary on the oscillator tuning condenser trimmer. It is very seldom necessary to make any readjustments at 1400 kcs. after they have once been made.

Now tune the Test Oscillator to 1000 kcs. and tune the set to 1000 kcs. Try adjusting the antenna trimmer condenser to determine whether the oscillator aligns at this frequency. If the antenna trimmer must increase capacity to give maximum deflection of output meter the oscillator tuning condenser serrated plates should be moved out. If the antenna trimmer condenser is decreased in capacity the oscillator tuning condenser serrated plates should be bent in towards the stator plates.

The Test Oscillator must again be set to 1400 kcs. and the set retuned to 1400 kcs. to make sure that the antenna trimmer condenser has been correctly reset after the oscillator adjustment has been made at 1000 kcs.

In making tests after having made adjustments according to the foregoing paragraphs, it is necessary to replace the tube and coil can shields before making the tests.

HOWARD RADIO CO.

MODEL H
Chassis
Top-Bottom View

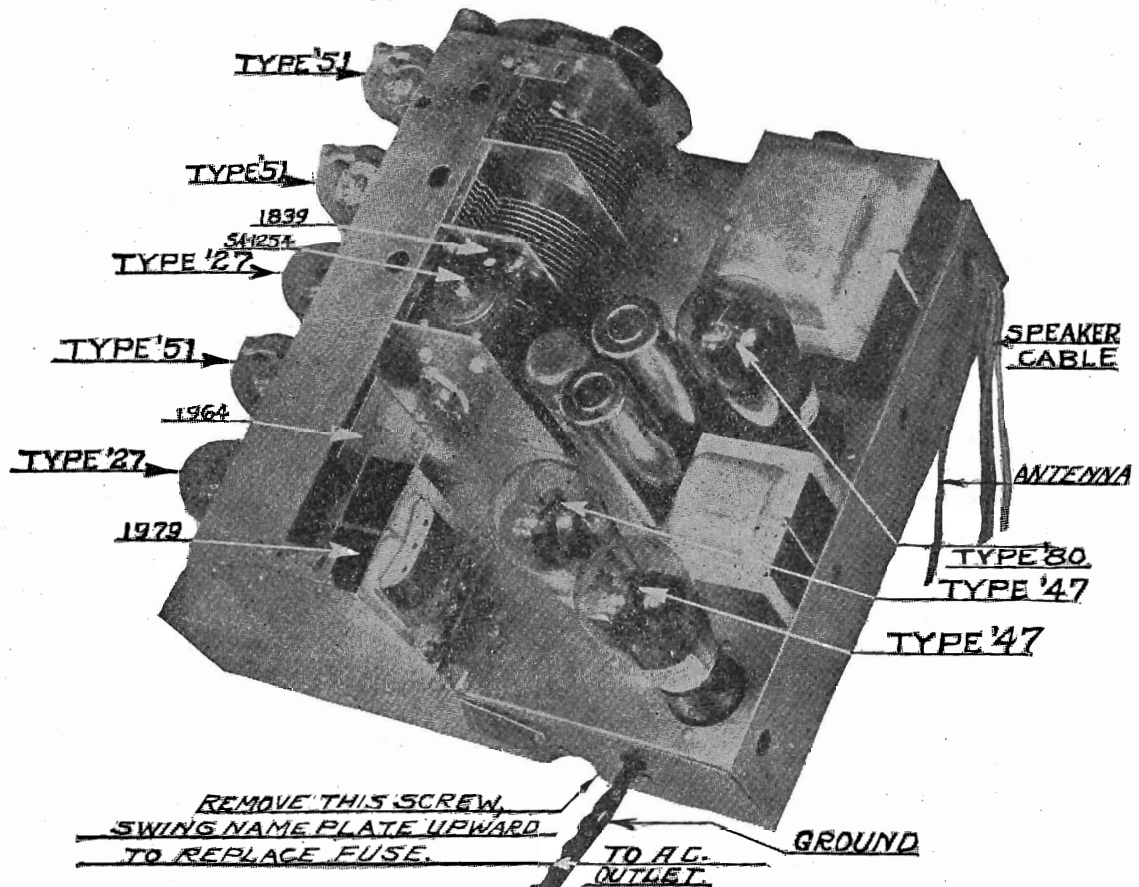
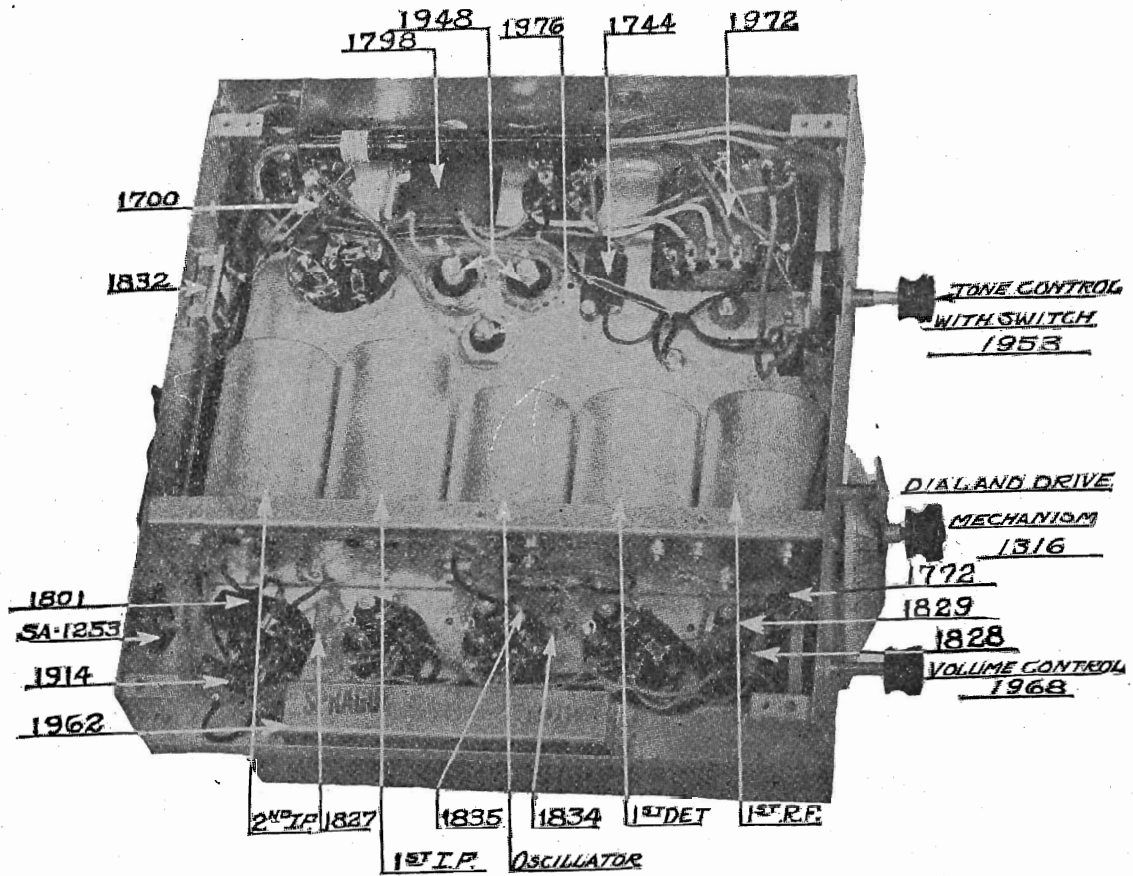

MODEL 45,60

(AVH)

Alignment Data

HOWARD RADIO CO.

This cycle goes on until a constant voltage is obtained across the second detector input or in other words until a condition of equilibrium is reached.

The action of the AVC is to maintain a constant voltage across the grid of the second detector regardless of the voltage of the incoming signal. Since this voltage remains constant this means that the audio output also remains constant.

In order to connect the grids of the various tubes to the AVC resistor, it is necessary to insert decoupling resistors P-1897 in each grid lead. These resistors are of such value as that in conjunction with the isolating condenser, they form a resistance capacity filter circuit so that any modulation from the AVC tube does not reach the grids of the other tubes.

Due to certain detector characteristics it is not advisable to control the 1st detector tube as much as necessary with the r.f. and i.f. tubes. The grid return of the 1st detector, therefore, goes to the center tap of the two resistors in the plate circuit of the AVC tube while the grid return of the r.f. and i.f. tubes go directly to the plate of the AVC tube.

4. Volume Level Control.

In the automatic volume control set the receiver is designed so that the maximum audio output is just below the point of overload of the audio power tube. Since this value of output is far more than necessary for normal room volume, it is necessary to introduce some type of volume level control in order that the customer may adjust the output to any desired value. In order to accomplish this a variable resistor is shunted across the secondary of the input transformer to the pentode tubes. By adjusting this control, the volume may be set at any desired level and once adjusted need not be adjusted until it is desired to receive an extremely distant station which has a field strength too weak to operate the automatic volume control.

5. Tone Control.

Since the volume level control on the Model AVH is connected where the tone control is normally connected, it was necessary to re-design the tone control for this location. The tone control consists of two condensers P-1845 and a variable resistor P-1881. This combination is connected in series across the plates of the two pentodes. The action of this control is the same as that on the Model H in that as less resistance is included between the two condensers, they become more effective in by-passing the higher audio frequencies and at the same time they tune the primary of the output transformer to a lower audio frequency.

6. Visual Tuning Meter.

Since the Automatic Volume Control tends to hold the audio output of the set to a certain definite volume level, it will be at once apparent that the main tuning dial may be rotated quite a distance without any appreciable change in audio volume. This means that the point of resonance is hard to distinguish. In order to tune the receiver to absolute accuracy, a visual tuning meter is used. This meter is connected in series with the plate supply voltage of the three control tubes. As the bias increases on these tubes as the receiver is tuned to resonance, the plate current decreases. This decrease in plate current is recorded by the meter. A station is in exact resonance when the tubes are drawing their minimum plate current for a given signal strength. At this condition the best tonal qualities are realized from the set. It is important that the service man and dealer both understand this tuning so that the customer may be instructed in the correct manner of tuning his radio set. This action is explained fully in the instruction pamphlet with each receiver and should be thoroughly understood so that an explanation can be given the customer.

7. Power Pack.

The power pack is of the conventional type and is similar to the Model H with a few exceptions.

The power transformer has a separate winding for the heater of the AVC tube. This is necessary because if the heater were grounded as the other heaters, it would place 100 volts potential difference between cathode and heater and it is possible that rectification might take place between these two elements which would hinder the action of the AVC tube.

The HV. secondary of this power transformer is also changed to give an increased high voltage. This increase is necessary because the AVC tube requires an additional 124 volts for operation.

Since an additional 124 volts is required above the usual 180 volts for plate operation this means that from +B to -B on the voltage divider resistor there is a total of 304 volts. As our power tubes require only 250 volts plate and 16.5 volts bias it is at once apparent that they may be connected between +B and -B with suitable resistors to drop the voltages to the correct operating voltages.

The speaker field is connected the same as in the Model "H" but since the total current of the set now flows through the speaker field the resistance of the field is only 350 ohms instead of 2400 ohms as in the standard Model H.

The filter condensers on the Model AVH are of the dry electrolytic type since there would exist a potential difference between the case and the chassis if the wet electrolytic were used which might shock the user if he happened to touch the can of the condenser and the chassis. These dry electrolytic condensers are housed in a container which is at ground or chassis potential so that this danger is eliminated.

Two pilot lights are used on the Model AVH, one for illuminating the dial and the other for illuminating the meter.

1. Specifications.
The Howard Model AVH receiver is a superheterodyne receiver similar to the Model H receiver with the addition of an Automatic Volume Control.

2. Schematic Circuit.

Draw # 1481 shows a schematic diagram of the Model AVH. Since the Model "H" and Model "AVH" are nearly identical, it will only be necessary to show where in the two differ.

In the radio chassis the following differences are noted.

The first radio frequency transformer SA-1267 is not grounded as in the Model "H". A non-inductive 1 mfd. condenser is connected between the end of this coil and ground. This condenser provides an insulation as far as direct current is concerned for the grid of the radio frequency amplifier tube. From a radio frequency standpoint, this condenser offers a high impedance path to ground for the radio frequency voltage. Since this condenser and the impedance path to ground are in series across the tuning coil it is necessary that this condenser be large in order to have small effect on the tuning capacity.

The second radio frequency transformer SA-1268 is constructed in the same manner as the first radio frequency transformer as far as grounding is concerned and needs no further explanation. For actual physical construction refer to section 2 of Model "H" Service Manual.

The first intermediate frequency transformer SA-1278 also has an isolating condenser in the grid circuit. This condenser serves the same purpose as those in the radio frequency transformers.

The initial operating bias for the various tubes is secured by means of individual resistors in each cathode circuit. The plate current flowing through this resistor causes a voltage drop across it which places the cathode positive with respect to ground. Since the grid is effectively at ground potential this is the same as placing a negative voltage on the grid. It is necessary to bias these tubes individually so that there is no common impedance which might give rise to reaction between the tubes. Each resistor is by-passed to form a low impedance path for radio frequency around the resistor.

3. Automatic Volume Control.

The Automatic Volume Control is actuated by means of a type 227 tube and in order to explain its operation it is necessary to explain its action under condition of no signal being received and then its action when a signal is being received.

The tube is connected so that the grid is at absolute -B potential by means of a 2 megohm resistor (P-1889). The cathode of the tube is connected to a point on the voltage divider which is at +24 volts with respect to -B or the grid. There exists then between the cathode and the grid a potential difference of 24 volts with the grid negative by this amount. The plate of this tube is connected to ground by means of two 150,000 ohm resistors (P-1868). Since ground is connected to +124 volts with respect to -B there exists between the cathode and the plate a potential difference of 100 volts. In order to by-pass any radio frequency energy which may appear on the plate a non-inductive condenser (P-1893) is connected from the plate of the Automatic Volume Control tube to the cathode.

With the condition of no signal there exists a bias of 24 volts and a plate voltage of 100 volts. Under these conditions there is no plate current flowing and the tube is said to be cut-off. Since no plate current is flowing there exists no voltage drop across the plate circuit resistors and, therefore, there is no bias voltage on the grids of the controlled tubes. The only bias on the r.f., 1st det. and i.f. is caused by the respective voltage drops across their cathode resistors. These resistors are designed to give the most sensitive operating point.

Now let us consider the case of a received signal. The signal passes through the receiver to the second detector grid. Here the AVC (automatic volume control) tube grid and the second detector grid are in parallel. The signal voltage is fed to the grid of the AVC tube by means of a small fixed condenser P-1892. This signal voltage swings back and forth with its center coinciding with the initial bias on the AVC tube. It will be seen that during the positive half of the cycle, the peak voltage of the signal swing subtracts from the original bias voltage. This means that the instantaneous bias on the tube is less than the original bias and the tube begins to draw current in the plate circuit. Since this current flows in the resistors in the plate circuit of the AVC tube, there exists a voltage drop across these resistors.

Also the flow of the electrons is from plate to ground so that the plate becomes negative with respect to ground. Now since the original potential of the cathodes of the r.f., 1st det. and i.f. tube is positive with respect to ground, it follows that if the grids of the respective tubes are connected to resistor in the plate circuit of the AVC tube, that any potential existing across this resistor is added to the original bias and makes the grids more negative than the original bias by the amount of the voltage drop across the resistor in the AVC tube plate.

It is at once apparent that the greater the signal voltage appearing at the grid of the AVC tube, the more plate current will flow in plate circuit. An increase in plate current means an increase in bias on the r.f., 1st det. and i.f. tubes. An increased bias on these tubes means less amplification and therefore, less grid swing on the second detector and AVC tube.

MODEL 20,25,30,32

(0)

Schematic

HOWARD RADIO CO.

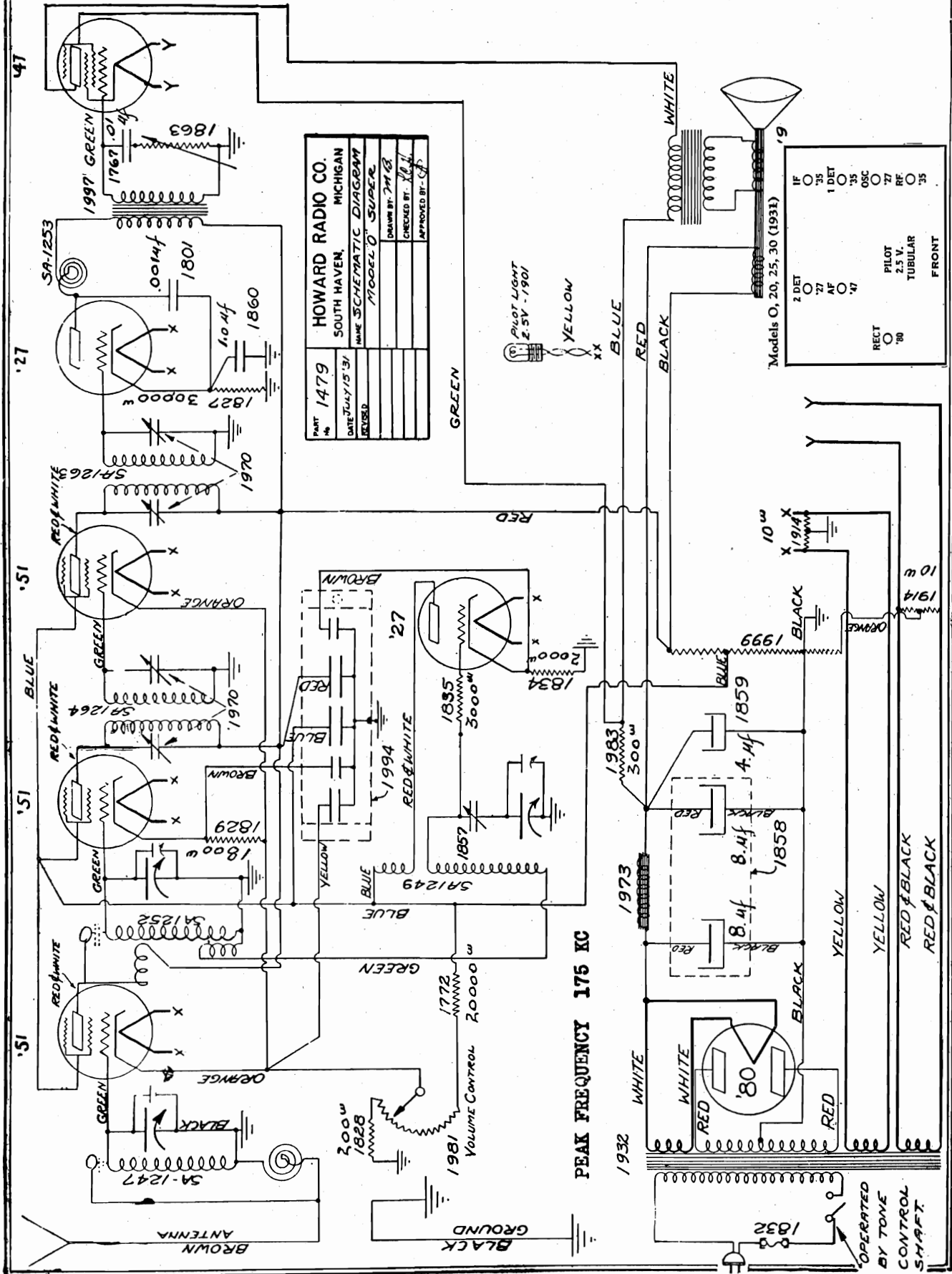

HOWARD RADIO CO

4. Tune primary of intermediate transformer for maximum deflection of output meter. Retune secondary to make sure tuning of primary has not affected the resonant point of secondary.
5. Replace grid cap as originally. Remove grid cap of the 1st detector and connect the 3 megohm resistor from control grid to ground. Connect the output of 175 kc. oscillator to control grid of 1st detector.
6. Tune secondary of 1st intermediate frequency transformer to 175 as shown by maximum deflection of output meter.
7. Now tune primary of this transformer to 175 as indicated by maximum deflection of output meter. Retune secondary to see it has not been affected by primary tuning.
8. Retune second intermediate frequency transformer to make sure it is exactly tuned at 175 kc. as there may be some change in tuning when the 1st detector is connected in the circuit.

No. 1 Radio Frequency Amplifier Alignment

1. After aligning IF transformers, replace 1st detector grid cap. Unsolder the wire connecting the plate of the 1st detector tube to the IF transformer. Remove oscillator tube and 2nd detector tubes. Connect the plate terminal of 1st detector tube to the plate terminal of the second detector socket.
2. Rotate the condenser in clockwise direction as far as they will go. Make sure that when the rotors of the condenser are all in that the starting mark on the dial aligns with the pointers on the eschutcheon. This starting mark is the line just beyond the 550 kc. line on the dial. (See Fig. 1.)
3. Set test oscillator (RF Generator) which tunes over broadcast band to 1400 kc. Connect antenna and ground wires to oscillator. Tune set to 1400, as shown on dial. Adjust trimmer on first and third variable condensers for maximum deflection of output meter.
4. Now tune oscillator 1000 kc. and tune set to 1000 kc. as shown on the dial. Adjust for maximum deflection on output meter by moving serated plates on rotor of tuning condensers in or out as the case may be. Do not adjust trimmer condensers at this frequency.
5. Repeat process in paragraph 4 at 600 kc.
6. Remove wire soldered from 1st detector plate terminal to second detector plate terminal and resolder wire from intermediate frequency transformer to plate terminal of 1st detector as originally connected.

Oscillator Alignment

1. Set test oscillator to 1400 kc. Tune set to 1400 kc. and adjust oscillator or second (middle) tuning condenser trimmer for maximum output as shown on the output meter. (Oscillator trimmer condenser second hole of the three in line.)
2. Set test oscillator to 600 kc. Tune set to 600 kc. Adjust oscillator padding condenser (angle hole to left of three holes in line) for maximum deflection of output meter.
3. Reset test oscillator again to 1400 kc. and retune set to 1400 kc. Readjust oscillator trimmer if necessary. This adjustment is very seldom necessary if the other adjustments are made correctly.
4. Now tune test oscillator to 1000 kc. and tune set to 1000 kc. Try adjusting antenna trimmer condenser to determine whether the oscillator aligns at this frequency. If the antenna trimmer must increase in capacity to give maximum deflection of output meter the oscillator tuning condenser serated plates should be moved out. If the antenna trimmer condenser is decreased in capacity the oscillator tuning condenser serated plates should be bent in towards the stator plates. It must be remembered that a small capacity change in the oscillator circuit means a tremendous frequency change, and this adjustment must be made very carefully.
5. Now adjust test oscillator to 1400 kc. and retune set at 1400 kc. to make sure that the antenna trimmer condenser has been reset to its original position after Test 4 has been made.

In making the above tests it is necessary before making each test, to replace all shielding. The foregoing tests are of a delicate nature, and it is essential that each one be made carefully before going to the next test.

Schematic Circuit
The schematic circuit of this receiver is shown in Dwg. No. 1479. The antenna connects to the set by means of the brown flexible lead shown in Fig. 1. The ground also connects to the set by means of a black flexible lead also shown in Fig. 1. (In later models binding posts are provided for antenna and ground.)

Inside the set, the antenna lead goes to a high inductance primary. The other end of this inductance grounds to the metal chassis. From the antenna end of this inductance a single turn of wire is coupled capacitively to the secondary of the radio frequency transformer. This coil is made in this manner so that the amplification will be equal throughout the frequency band. The secondary is tuned by means of a section of a three gang condenser. One end of this secondary connects to the control grid of the radio frequency amplifier tube while the other end is grounded.

The plate circuit of the radio frequency amplifier tube connects to +B voltage through a high impedance choke coil. The plate circuit of the r.f. amplifier is coupled to the secondary circuit by means of a single turn of wire in close physical relation to the grid end of the secondary coil which connects to the grid of the first detector or mixer tube. This single turn gives the necessary capacity coupling to produce uniform amplification over the broadcast frequency spectrum. The secondary coil of this transformer is tuned by a second section of the three gang variable tuning condenser. As with the secondary of the radio frequency amplifier transformer, one end of this coil is connected to the control grid of the first detector tube. The other end of this secondary coil is grounded to the chassis.

In order to introduce the oscillator voltage into the grid circuit of the mixer or first detector tube a small coil is wound in inductive relation to the secondary coil at the grounded end of the secondary. This small coupling coil is insulated from the secondary by means of a pyralin strip.

This small coil is a part of the oscillator inductance. Tuning of the oscillator is accomplished by means of the third section of the three gang variable tuning condenser, which has in series with it a fixed padding capacitor. This padding condenser has across it a small trimmer condenser. This condenser tunes the oscillator to an exact frequency at the low frequency end of the spectrum. One end of the oscillator coil is grounded through the 1st detector coupling coil while the other end connects to the control grid of the oscillator tube by means of a resistor P-1835 (Dwg. 1479). This resistor is used to stabilize the oscillator voltage over the frequency range. The plate circuit of the oscillator contains the conventional tickler coil, and is connected to the screen grid voltage tap for its plate voltage. The oscillator is of the biased type having a bias resistor connected from the cathode to ground. This resistor is by-passed by a section of the by-pass condenser block.

Voltage and Current Readings Howard Model "O"

Tube No.	Type	Position	A Volts	B Volts	Screen Volts	C Volts	Plate Current M.A.	Screen Current
1	551	1st R.F.	2.20	180	92	— 3.5	5.4	5.4
2	227	Osc.	2.20	88	—	— 10.0	2.8	—
3	551	1st Det.	2.25	175	90	— 8.0	2.5	—
4	551	I.F.	2.25	180	92	— 3.5	6.2	—
5	227	2nd Det.	2.30	160	—	— 17.0	0.6	—
6	247	Audio	2.35	260	270	— 21.0	25.0	4.2
7	280	Rectifier	4.60	350-350	—	—	—	—

Volume Control, Full On.

(1) Alignment

IMPORTANT. The 175 kc. oscillator must be accurately tuned to 175 kc. If this precaution is not observed it will be impossible to align the oscillator to the rest of the set and the set will not operate correctly as the oscillator is designed for exact 175 kc. operation.

This set is designed slightly different from the Model H superheterodyne in that the second intermediate frequency transformer is not overcoupled.

The following alignment procedure should be followed:

A Intermediate Transformer Alignment

1. Remove grid cap from intermediate frequency amplifier tube and connect the control grid of this tube to a 2 or 3 megohm resistor. Connect other end of this resistor to ground.
2. Connect output of 175 kc. oscillator to control grid circuit of this tube.
3. Tune secondary of intermediate transformer for maximum deflection of output meter. (Low voltage alternating current meter, 0.5 volts connected across voice coil of speaker.)

HOWARD RADIO CO.

MODEL 10
(T)
Alignment Data

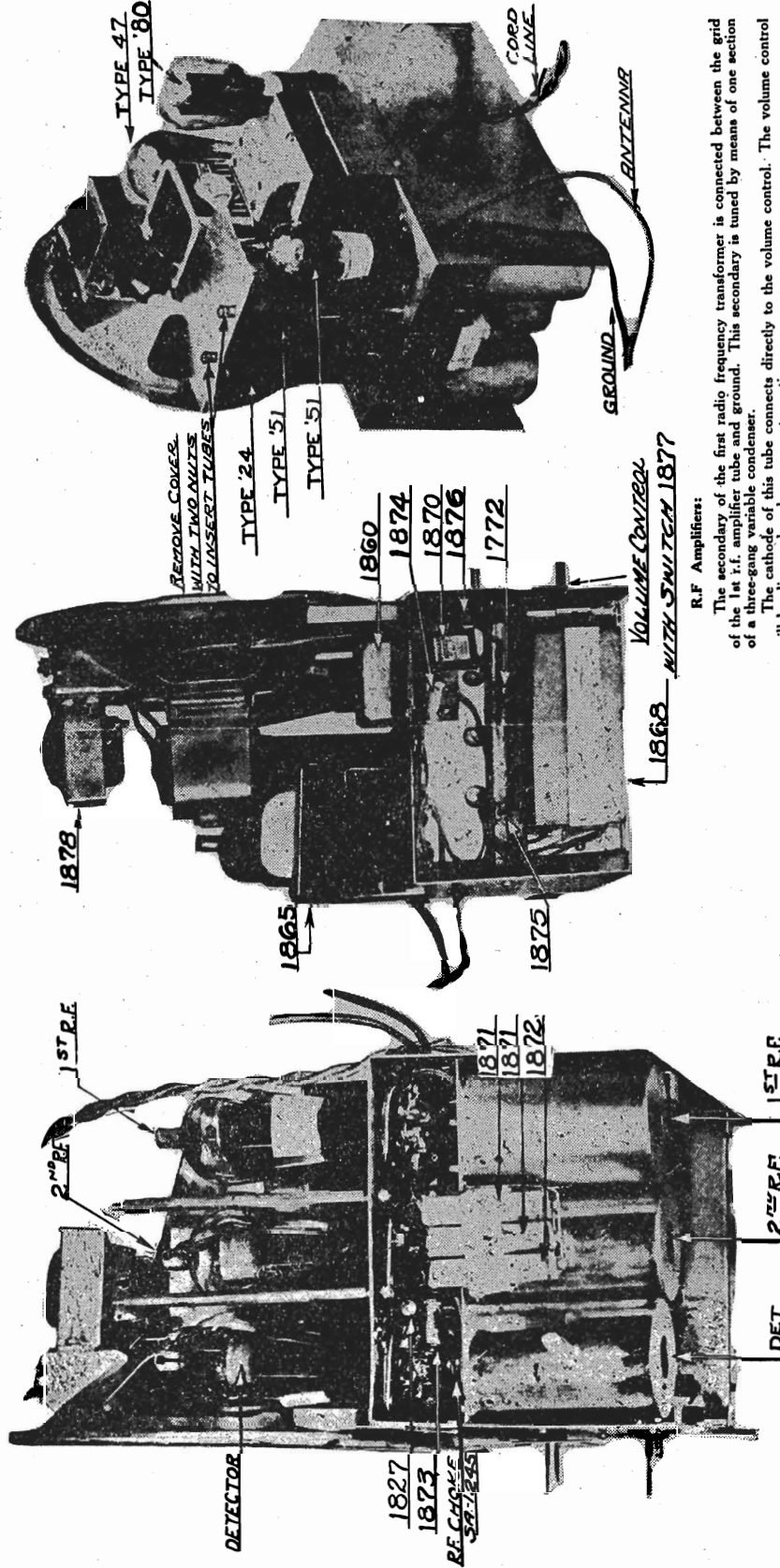

1323	Condenser, variable tuning condenser, 3 gang	1870	Condenser 1 mfd. Sprague Type G..
1325	Tuning mechanism (complete with scale)...	1871	Condenser 1.0 mfd. Elkon 200 volt rating.
1562	Line cord, 8 1/2 ft., with H. & H. Bakelite plug.	1872	Condenser .5 mfd. Elkon 200 volt rating..
1702	Socket type, No. 280.....	1873	Resistance 100,000 ohms, 1/2 watt.....
1703	Socket type, No. 224.....	1874	Resistance 400,000 ohms, 1/2 watt.....
1705	Socket type, No. 551.....	1875	Resistor "B" stick.....
1772	Resistor 20,000 ohms 1/2 watt.....	1876	Resistor 750,000 ohms, 1/2 watt.....
1801	Condenser .001 mfd. Fixed mica.....	1877	Volume Control (on-off switch included)...
1812	Condenser .5 mfd.	1914	Resistor 10 ohms center tapped type 7E-10.
1827	Resistance 30,000 ohms, 1/2 watt.....		
1847	Socket type, No. 247.....		
1816	Condenser 1.0 mfd.		
1865	Power Transformer, No. H.R. 55.....		
1868	Condenser 16 mfd. (2-8 mfd. sections)...		

R.F. Amplifiers:

The secondary of the first radio frequency transformer is connected between the grid of the 1st r.f. amplifier tube and ground. This secondary is tuned by means of one section of a three-gang variable condenser.

The cathode of this tube connects directly to the volume control. The volume control will be discussed under a separate section.

The screen grids of the radio frequency amplifier tubes connect together and then to a point on the voltage divider resistor which applies the correct operating potential on the screens. In order to prevent common coupling impedance these screens are by-passed to ground by means of a condenser. This eliminates a possibility of oscillation from this source.

Connected between the source of B voltage and the plate of the first radio frequency amplifier tube is a high inductance choke coil. This coil is located in the top of the second radio frequency transformer but in physical relation to the secondary of this transformer so that there is no electromagnetic coupling. Connected to the plate end of this transformer is which is in close physical relation to the grid end of the secondary of this choke is a wire in the case of the 1st r.f. transformer, this turn gives a small capacity coupling. The combination of the choke and small capacity formed by the single turn of wire gives a frequency characteristic which is substantially flat over the frequency range.

The secondary of the second transformer is similar to the one used in the 1st r.f. transformer and is tuned by means of the second section of the variable tuning condenser. It is connected between grid and ground of the second radio frequency amplifier tube.

The cathode and screen of this tube are connected the same as the first radio frequency amplifier and need no further description.

The third radio frequency transformer is a duplicate of the second radio frequency transformer and therefore, needs no description. On export models, the ground lead of this transformer is connected to a phonograph jack, and the other terminal of the phonograph jack is connected to ground. In the radio position, these jacks are shorted by means of a switch. In the phono. position, this switch is opened and the pick-up is plugged into the jacks. It is necessary to tune the radio set to some point on the dial where there is no signals from a broadcast station coming in, otherwise the radio signals will feed through and interfere with the phono music.

Sub-Assembly Parts List

- SA-1245 R.F. Choke coil
- SA-1281 Radio Frequency Transformer (Antenna)
- SA-1282 Radio Frequency Transformer (Interstage)

HOWARD RADIO CO.

MODEL O
Chassis
Top-Bottom View

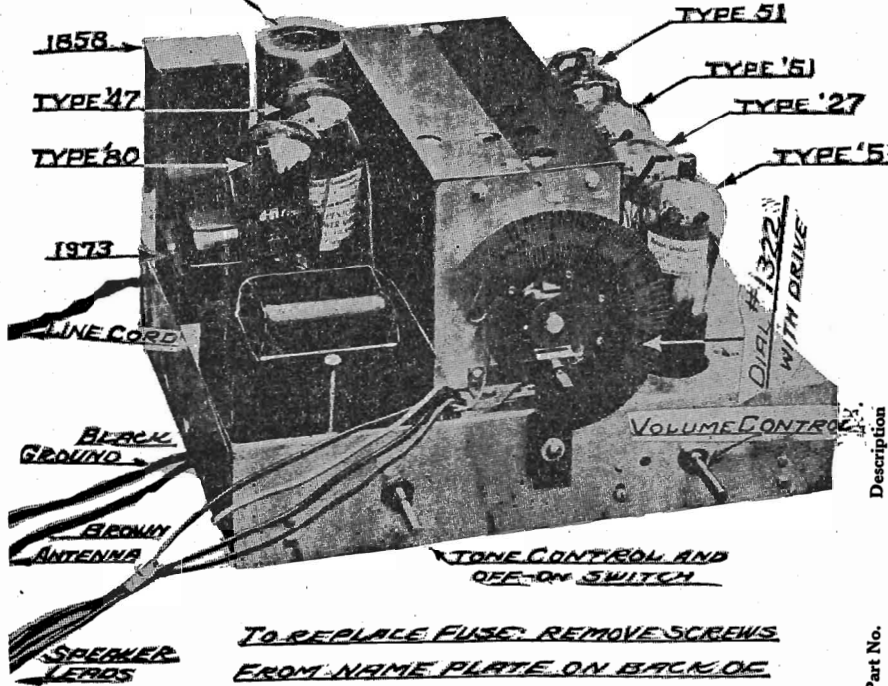
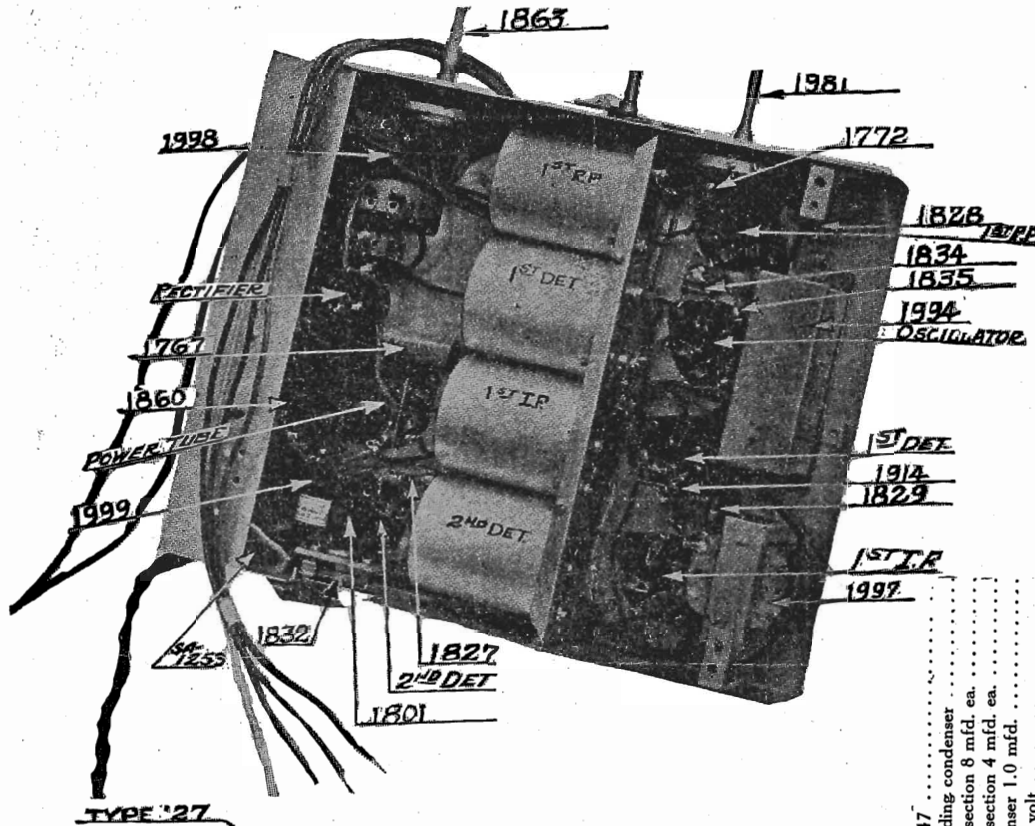

TO REPLACE FUSE, REMOVE SCREWS FROM NAME PLATE ON BACK OF CHASSIS.

Part No.	Description	Sub-Assemblies
1263	IF transformer coils 1 1/16" spacing	
1264	IF transformer coils 1" spacing	
1318	Variable tuning condenser	
1322	Dial drive mechanism and scale No. 2042	
562	AC line cord and plugs	
1702	Socket No. 280	
1704	Socket No. 227	
1705	Socket No. 551	
1767	Condenser .01 mfd.	
1772	Resistor, 20,000 ohms, 1/2 watt	
1801	Condenser .001 mfd.	
1827	Resistor 30,000 ohms 1/2 watt	
1828	Resistor 200 ohms 1/2 watt	
1829	Resistor 1800 ohms 1/2 watt	
1832	Fuse 2 amp. A.C.	
1834	Resistor 2,000 ohms 1/2 watt	
1835	Resistor 3,000 ohms 1/3 watt	
1847	Socket No. 247	
1857	Oscillator padding condenser	
1858	Filter cond. 2 section 8 mfd. ea.	
1859	Filter cond. 1 section 4 mfd. ea.	
1860	By-pass condenser 1.0 mfd.	
1901	Pilot light 2.5 volt	
1914	Resistor 10 ohm center-tapped	
1932	Power transformer	
4803	Tone control and power switch	
1970	IF transformer tuning condenser (variators)	
1973	Choke coil, power pack	
1981	Volume control	
1983	Resistor 300 ohm, 5 watt	
1994	By-pass condenser block	
1997	Audio transformer	
1999	Resistor (voltage divider)	
18247	Antenna radio frequency transformer	SA-1247
18249	Oscillator tuning coil	SA-1249
18252	Radio frequency transformer	SA-1252
18253	Detector radio frequency choke coil	SA-1253

INSULINE CORP. OF AMERICA

MODEL Envoy
6 Tube AC
MODEL Envoy
Midget

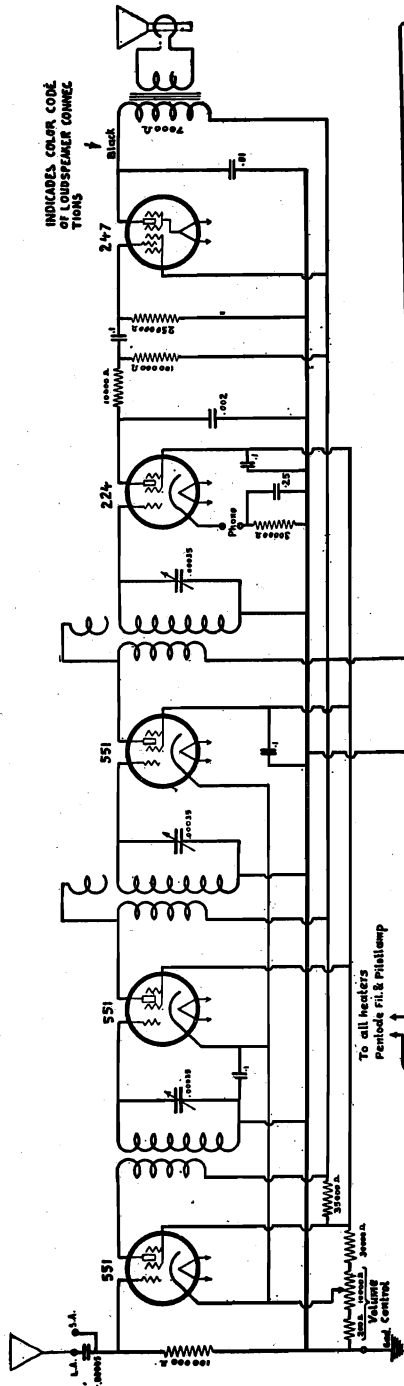

INDICATES COLOR CODE OF LOUSPEAKER CONNECTIONS

6 TUBE A.C. ENVOY RECEIVER
TYPE 110 & 220 V. 50-60 Hz. DATE, Dec. 3rd 1931
MODEL A.C. APPROVED R.H.S.
DRAWN M.P. INVENTOR 200-55911

LINE VOLTAGE MAY VARY FROM 105 TO 125 OR 210 TO 250 VOLTS.

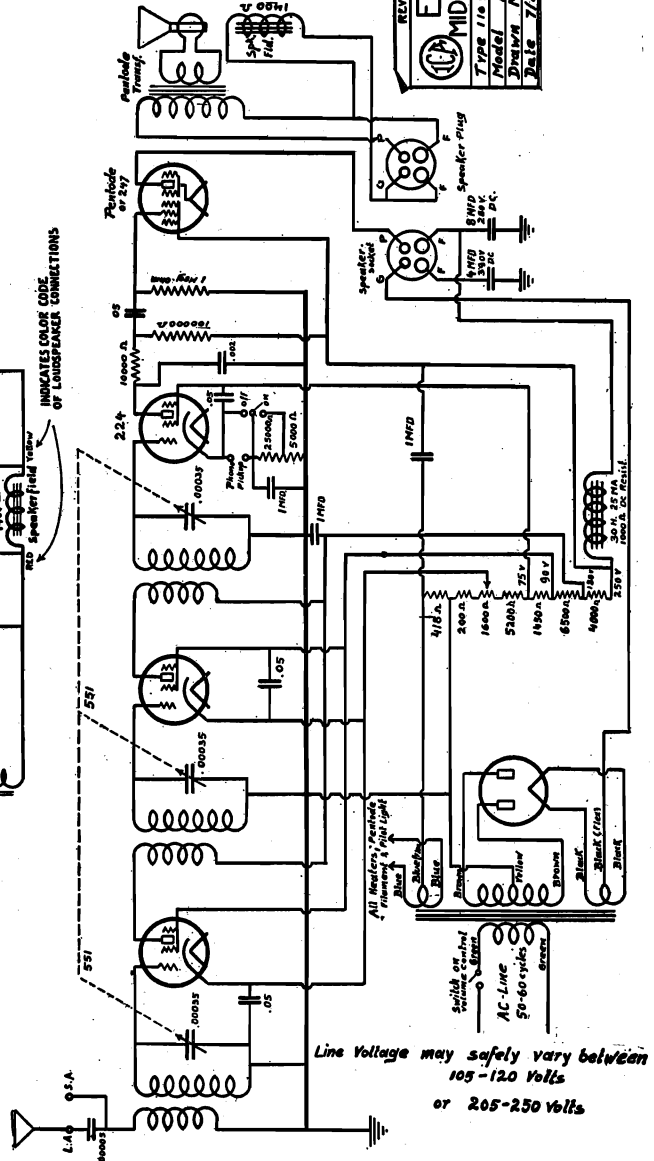

INDICATES COLOR CODE OF LOUSPEAKER CONNECTIONS

ENVOY MIDGET RECEIVER
Type 110 & 220 Scale
Model A.C. Checked: R.H.S.
DRAWN M.P. APPROVED: R.H.S.
Date 7/28/31

Line Voltage may safely vary between 105-120 volts or 205-250 volts

"ENVOY" 6-TUBE AC RECEIVER

"ENVOY" AC MIDGET RECEIVER

MODEL Envoy
Midget DC
(Revised)
2 Types

INSULINE CORP. OF AMERICA

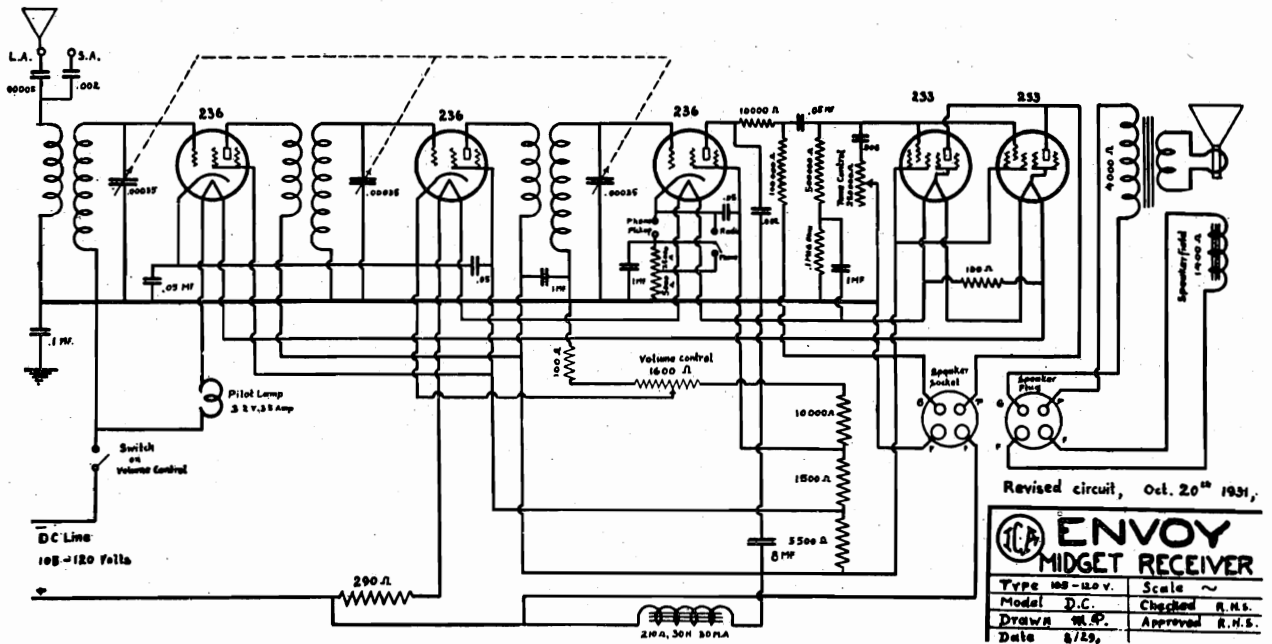
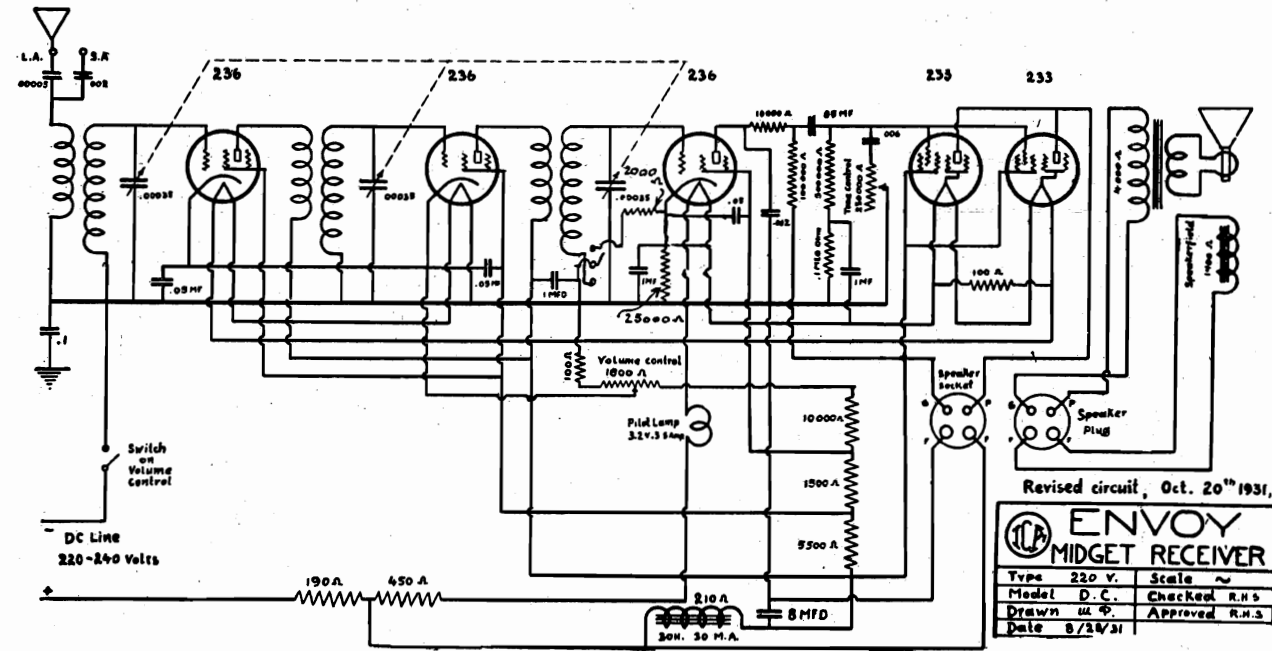

"ENVOY" DC MIDGET RECEIVER (220 V)

"ENVOY" DC MIDGET RECEIVER (105-120 V)

INSULINE CORP. OF AMERICA

MODEL Insulette & Mascot
 4 Tube Midget AC
 Broadcast-Long Wave
 4 Tube Midget AC

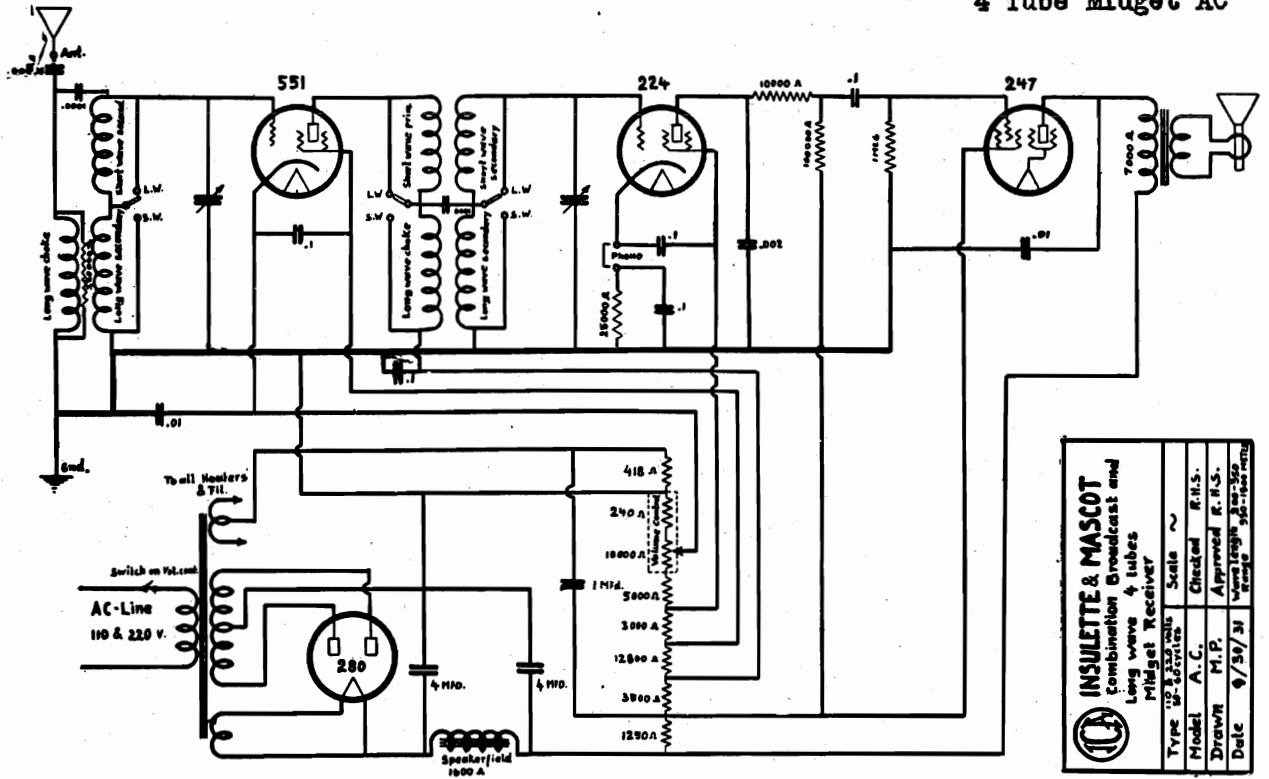

INSULETTE & MASCOT Combination Broadcast and Long wave 4 tubes Midget Receiver		Scale ~
Type 110 & 220 v.	Model A.C.	Checked R.H.S.
Drawn M.P.	Date 9/28/31	Approved R.H.S.
		Wavelength 100-550 meters

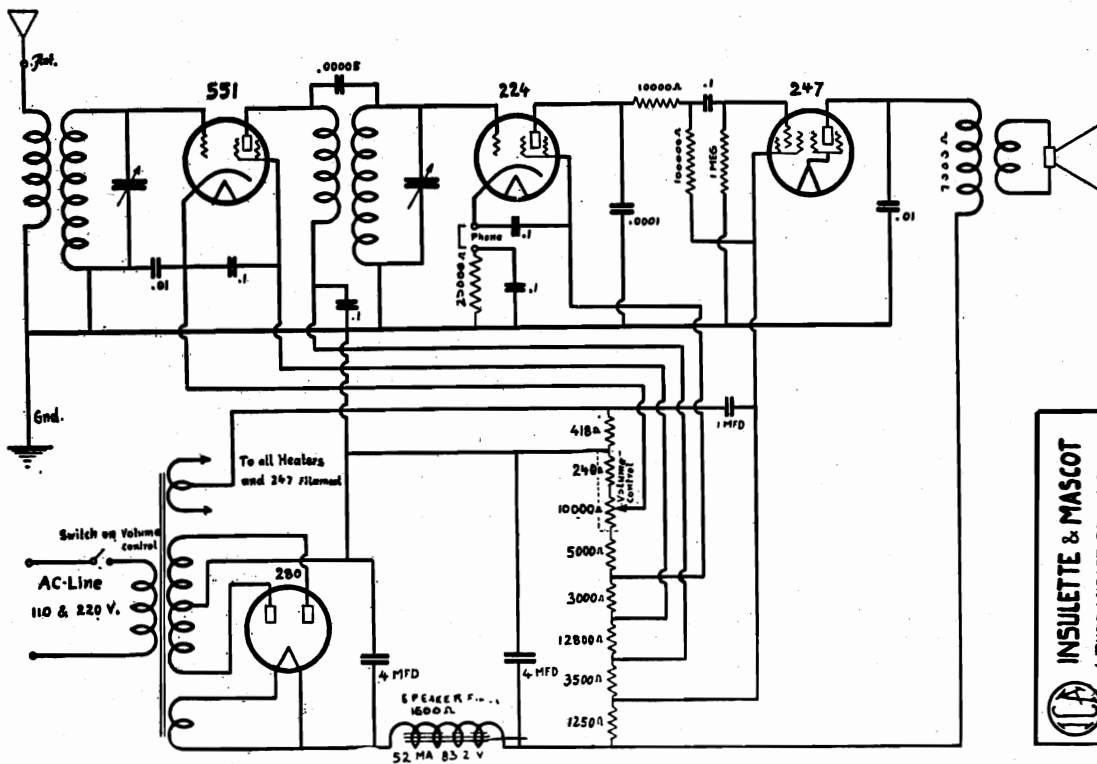

INSULETTE & MASCOT 4 TUBE MIDGET RECEIVER.		Scale ~
Type 110 & 220 v.	Model A.C.	Checked R.H.S.
Drawn M.P.	Date 9/28/31	Approved R.H.S.
		Wavelength 100-550 meters

"INSULETTE" & "MASCOT"
 4 TUBE MIDGET RECEIVER

"INSULETTE" & "MASCOT"
 4 TUBE COMBINATION B'CAST & L.W.
 MIDGET RECEIVER

MODEL Super-Conqueror
Short & Long Wave AC **INSULINE CORP. OF AMERICA**

 SUPER-CONQUEROR SHORT & LONG WAVE RECEIVER.	DATE	AUG. 23, 1933	MODEL	12 - 2025 METERS
	DRAWN	M.P.	DESIGNED	R.H.S.
	CHECKED	R.H.S.	APPROVED	A.G.H.
	TUBES		LBS.	
	MANUFACTURED BY INSULINE CORP. OF AMERICA 23-25 PARKPLACE NEW YORK, N.Y., U.S.A.			

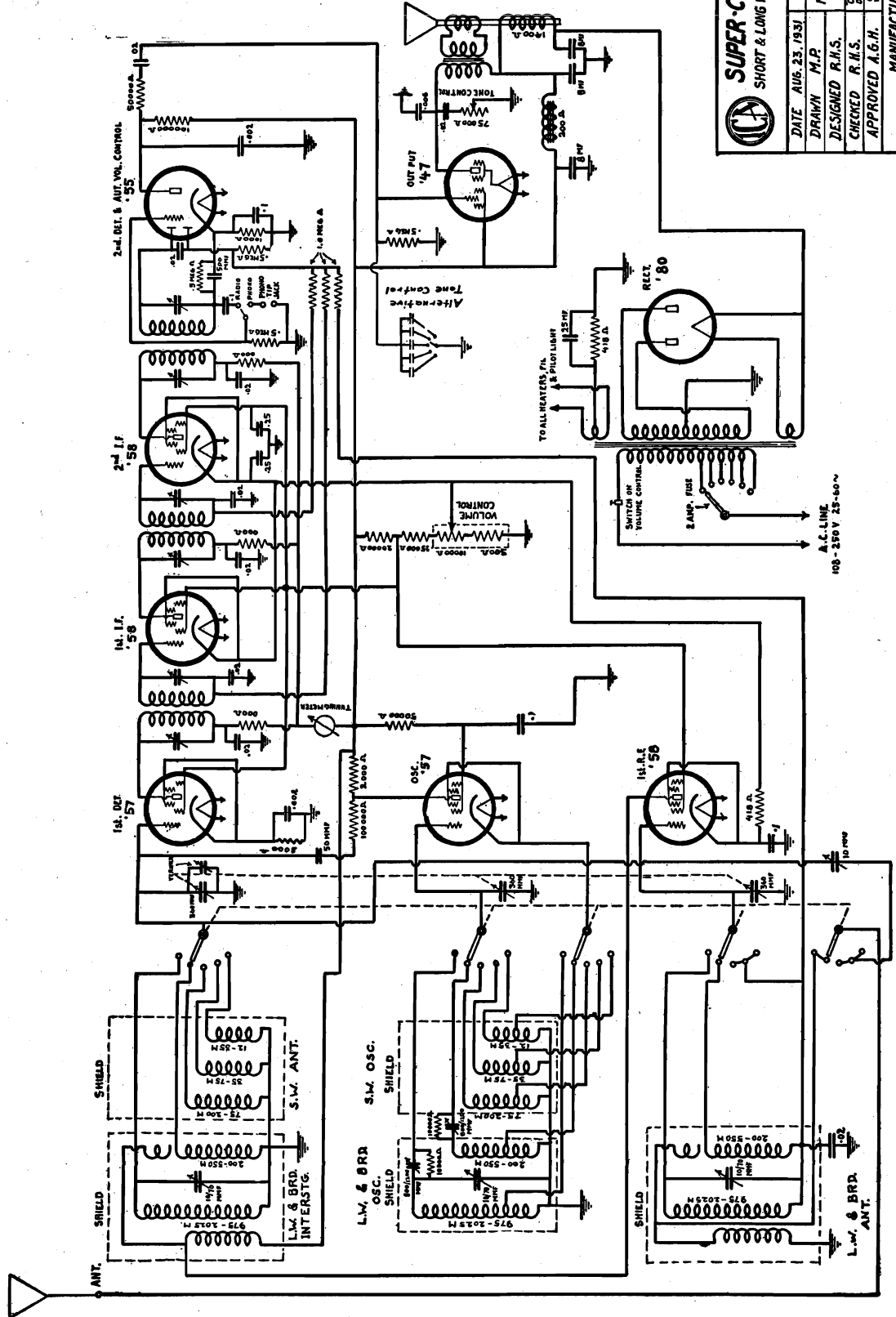

MODEL Universal Companion
AC-DC-Battery
Portable

INSULINE CORP. OF AMERICA

MODEL Universal Mascot
AC-DC

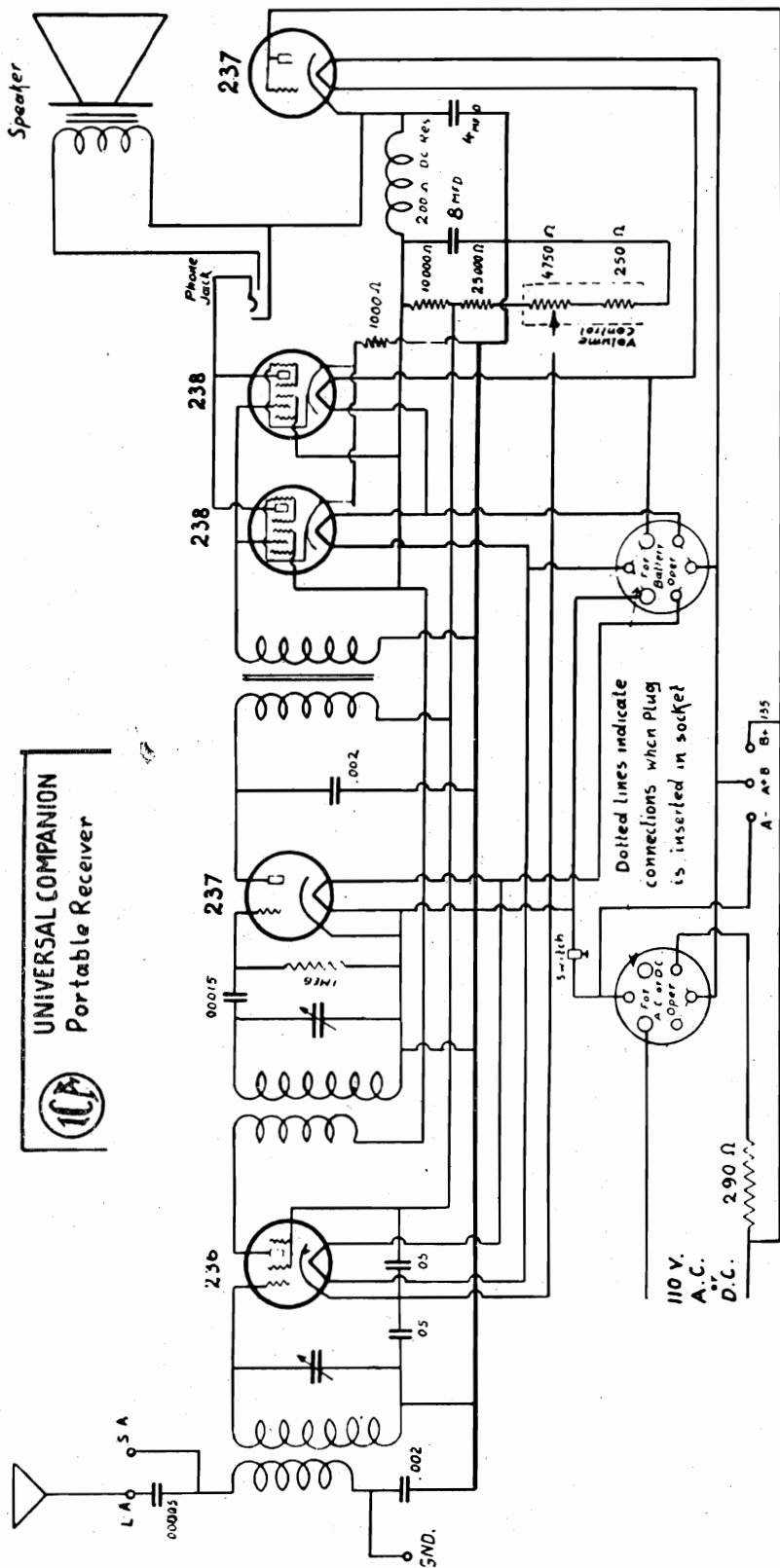

UNIVERSAL COMPANION
Portable Receiver



- #17 .00035 mfd
- #19 8.-8.-4. mfd
- #20 330 ohm choke

- 300-300,000 ohms
- 30,000 ohms
- .25 mfd 200 V.
- 5.-5. mfd Electro.
- 100,000 ohms
- 50,000 ohms
- 75,000 ohms
- 500,000 ohms
- .02 mfd 200 V
- 600 ohms
- 2000 ohms
- 170 ohms
- .002 mfd
- .1 mfd 200 V

- #3
- #4
- #5
- #6
- #7
- #8
- #9
- #10
- #11
- #12
- #13
- #14
- #15
- #16

WIRING DIAGRAM ICA UNIVERSAL MASCOT

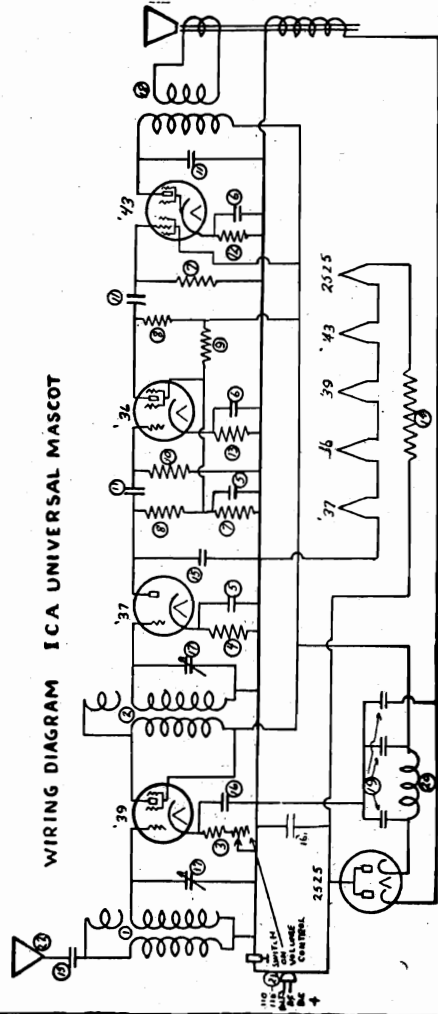

MODEL "Conqueror" INSULINE CORP. OF AMERICA
SW. Battery
Schematic

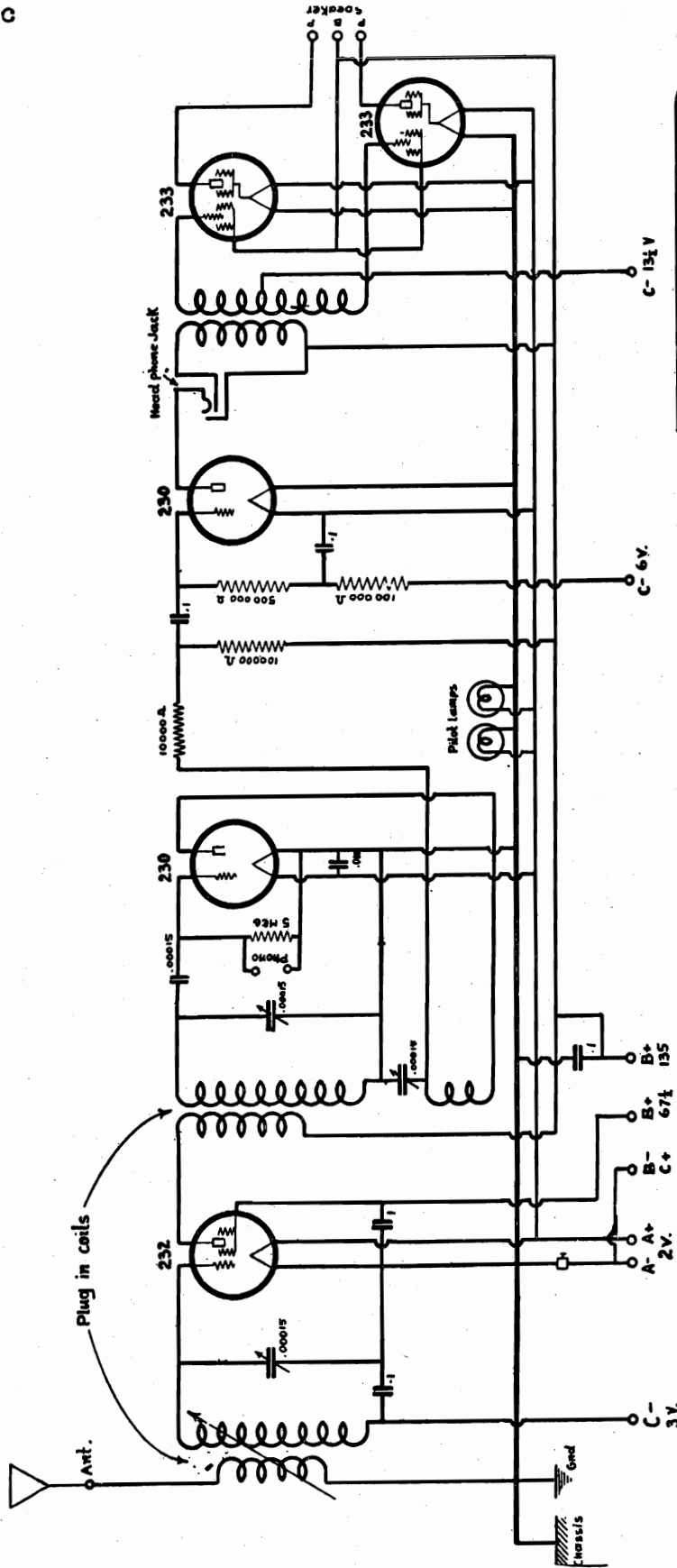

CONQUEROR SHORT WAVE BATTERY MODEL RECEIVER

Type	BATTERY	Scale	✓
Drawn	M.P.	Checked	R.H.S.
Date	11.27.31.	Approved	R.H.S.
Waves. 17 - 550 METERS			

NOTE: LOUD SPEAKER OR SPEAKER COUPLING TRANSFORMER SHOULD HAVE AN IMPEDANCE OF 7500 OHMS EACH SIDE OF CENTER TAP FOR MAXIMUM UNDISTORTED OUTPUT

"CONQUEROR" S.W. BATTERY MODEL RECEIVER

COLIN B. KENNEDY CORP.

MODELS 38 & 40
 MODEL 22
 MODEL 36

Tube Socket
 Diagram for
 Chassis
 Models
 Nos. 38 and 40

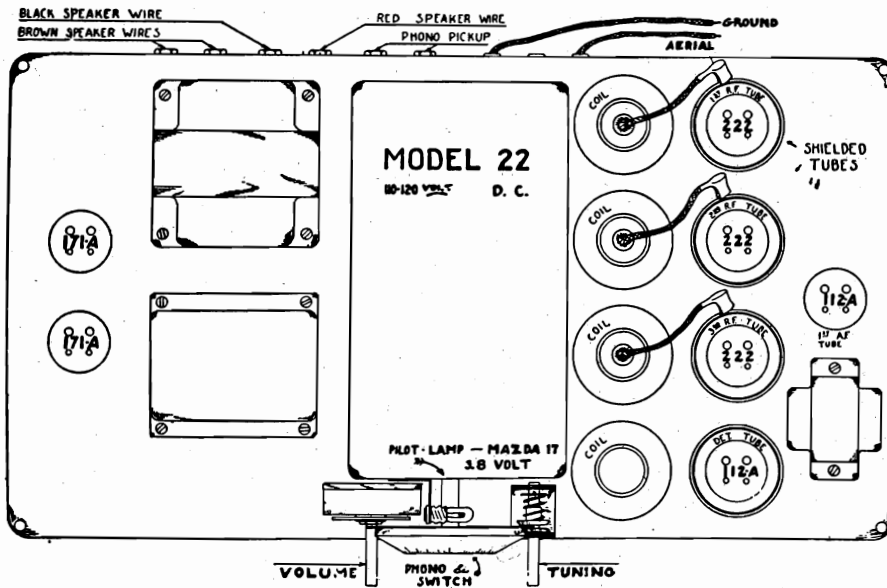
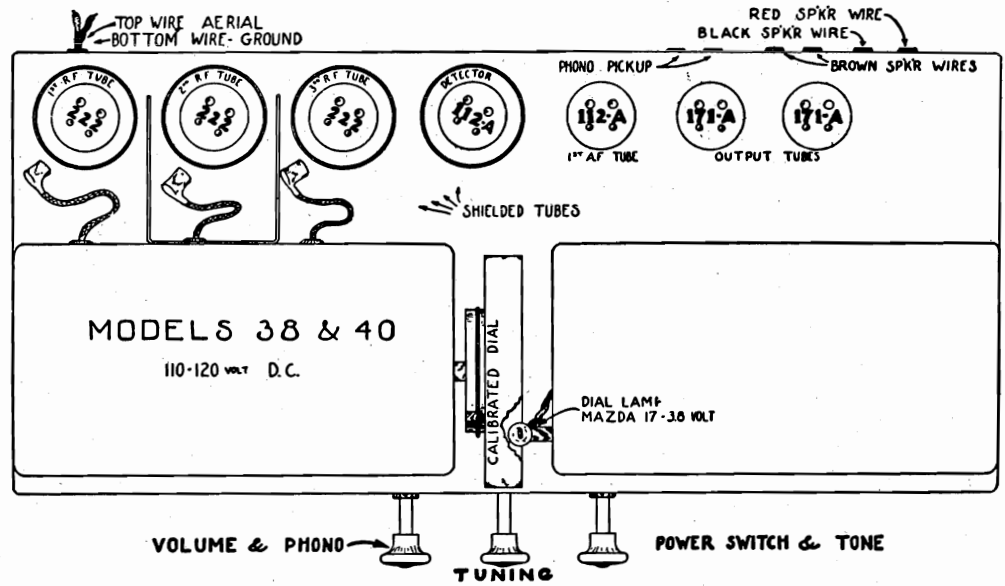

Tube Socket
 Diagram for
 Chassis
 Model No. 22

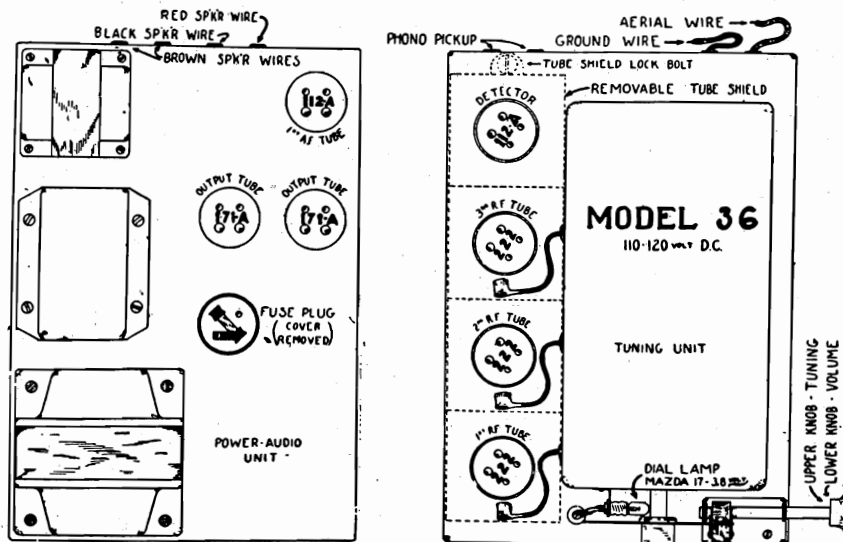

Tube Socket
 Diagram for
 Chassis
 Model No. 36

MODEL 24
Schematic, Data

COLIN B. KENNEDY CORP.

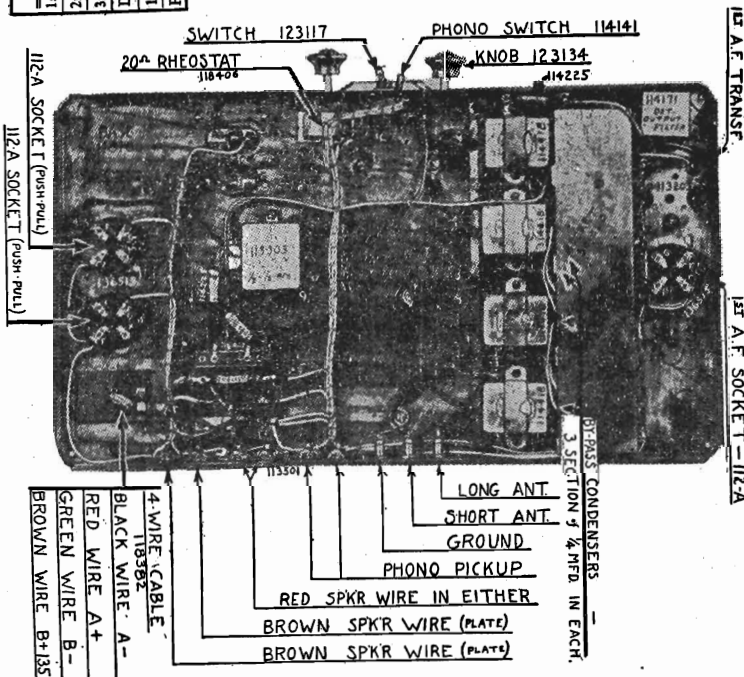
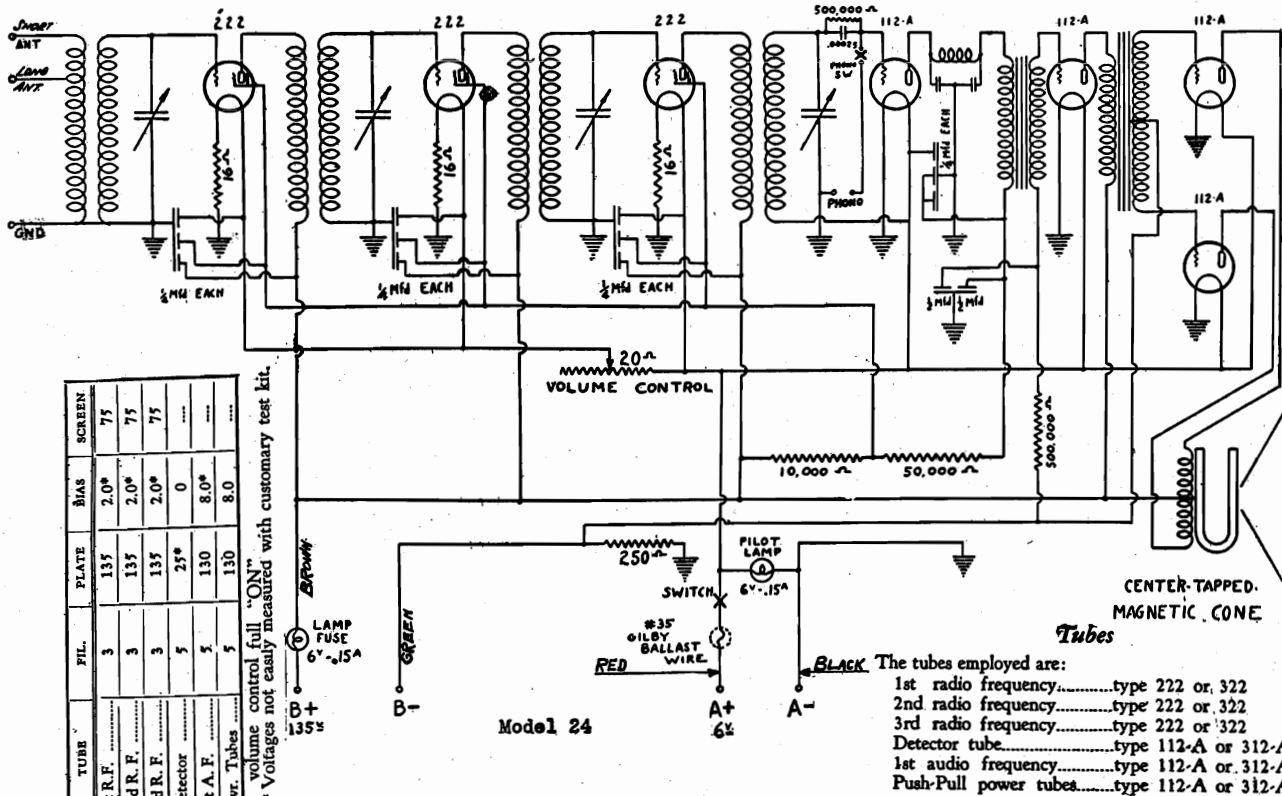

Tubes
The tubes employed are:
1st radio frequency.....type 222 or 322
2nd radio frequency.....type 222 or 322
3rd radio frequency.....type 222 or 322
Detector tube.....type 112-A or 312-A
1st audio frequency.....type 112-A or 312-A
Push-Pull power tubes.....type 112-A or 312-A

General Information:
THE KENNEDY Battery Operated Chassis Model 24 is enclosed in a box similar to the Kennedy Models 20 and 22 (A.C. and D.C. line models). A great many of the component parts of the battery operated chassis are interchangeable with those of the corresponding A.C. and D.C. line models, 20 and 22.
If set oscillates over entire dial range, it is possible that the detector output filter is defective, and a new one may be tried.
The wires at the tops of the coil shield (to control grids) may have been pulled sufficiently to bend coil lugs and permit more than 3/4 inches of wire (from shield to start of clip) to be exposed. Extra length here tends to cause an unstable receiver.
If receiver oscillates at just a small spot or two of dial range, it may frequently be corrected by pushing a piece of solid brass copper wire between the rubber grommet and coil shield (barely through) of the second R.F. coil shield, and twisting a few turns around the wire leading to the control grid of the 2nd R.F. tube.

Resistors
The resistance values of the various colored resistors employed are:
10,000 ohms.....Grey
50,000 ohms.....Yellow
500,000 ohms.....Brown

Fuses and Ballast
Under a coverplate near the battery cable will be found a pilot lamp bulb and a piece of small wire held by two parts. This bulb is used as a fuse in the "B" battery circuit and is identical with the pilot lamp—both being Mazda No. 40 (6 volt, 0.1 amp). The fuse lamp does not light up when set is operating, and it should do so if it is an indication of trouble elsewhere in the receiver.
The small wire held by the two positions is a fuse and ballast as a fuse it serves to compensate for variations in the voltage of the storage battery. Extra pieces of this wire are provided with the set, and it is IMPORTANT that no other wire be used. This wire is No. 34 B. & S. gauge Gilby ballast wire. If other wire is used there is danger of injury to the tubes.

In the event it becomes necessary to change a coil it is extremely desirable to change all four coils for a new set of four matched and impregnated coils that are designed to work together.
Tests for resonance, or matching of the tuned circuits, are accomplished with an oscillator—connections to the resonant circuits being made from ground to grid terminals of the R. F. sockets for the R. F. coils and from A+ terminal of detector socket to end of grid lead or grid condenser furthest from detector socket grid terminal for the detector coil.

Batteries
The model 24 receiver requires one six volt storage "A" battery and one 135 volt "B" battery (or three 45 volt "B" batteries). No "C" batteries are required as all bias voltages are obtained automatically within the receiver.
The storage battery drain is exceptionally low for this type of receiver, being approximately 1.37 amperes.

COLIN B. KENNEDY CORP.

MODEL 50
Schematic
Chassis
Alignment Data

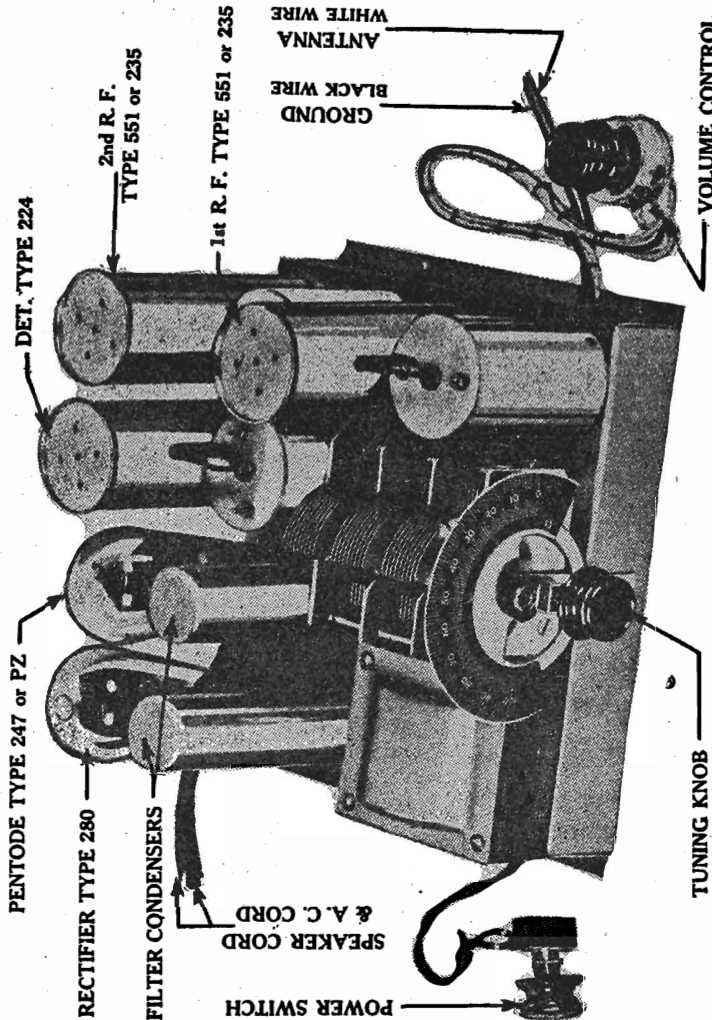
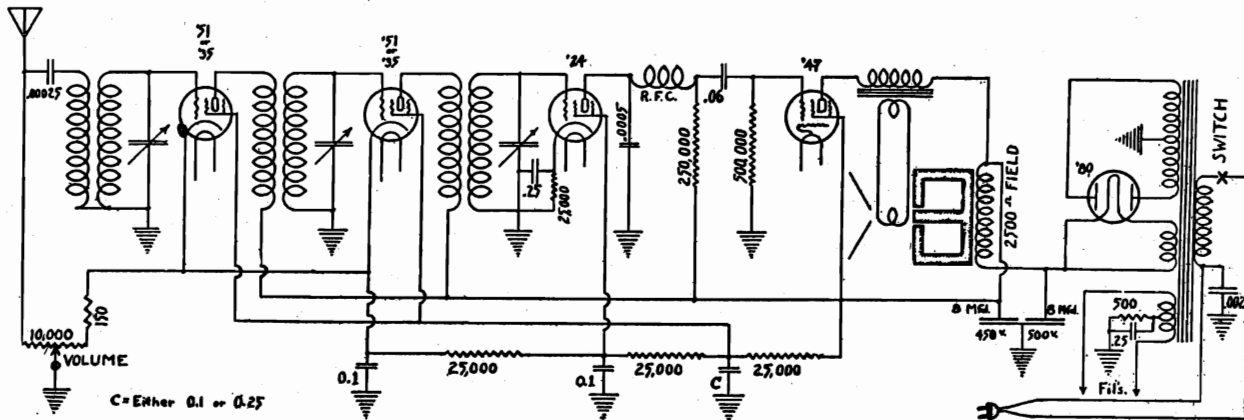

- Coils**
11759 Coils, set of 3 matched, shielded.....
- Condensers**
13417 Condenser, 1/4, 1/4 and 1/4 mfd., 300-volt.....
15417 Condenser, 1/4 and 1/4 mfd., 200-volt.....
13306 Condenser, 0.1 mfd. tubular 200-volt.....
13226 Condenser, 0.06 mfd. tubular 200-volt.....
11A473 Condenser, .0005 Mica
113306 Condenser, .002 Mica
113305 Condenser, .00025 Mica
15302 Condenser, 8.0 mfd. filter, 500-volt.....
16302 Condenser, 8.0 mfd. filter, 450-volt.....
13301 Condenser, three-gang, tuning

- Resistors**
114225 Resistor, 500,000-ohm graphite.....
114224 Resistor, 50,000-ohm graphite.....
117366 Resistor, 25,000-ohm graphite.....
114173 Resistor, 10,000-ohm graphite.....
114215 Resistor, 5,000-ohm graphite.....
12158 Resistor, 500-ohm vitreous.....
16406 Resistor, 10,000-ohm variable with 150-ohm fixed

Alignment

Alignment of the tuned circuits is made in the conventional manner. An oscillator covering the broadcast band and an output meter or indicator will be found helpful and will speed up the procedure.

The three circuits are first aligned at, or near, the 1,500 K. C. end of the dial. The first condenser section has a "trimmer" condenser which may be adjusted. The other two sections may be adjusted by bending the proper segments of the slotted rotor end plates. A check at four or five positions across the dial range is usually ample.

Tube	Type	Fil.	A.C.	Plate	Screen	Bias
1st R.F.	551	2.3	250	175	175	2.5 to 39
2nd R.F.	551	2.3	250	175	175	2.5 to 39
Detector	224	2.3	155	155	4	4
Power Tube	247	2.3	235	235	235	16
Rectifier	280	4.8	340-340

Line voltage = 115 Volume full on.

MODEL 53-SW
 MODEL 54-SW
 Parts List
 Data

COLIN B. KENNEDY CORP.

THE KENNEDY Model 53 short wave unit operates on the superheterodyne principle, and is commonly called a converter or adapter.

When switched to long wave position the power is shut off from the short wave unit. When switched to the short wave position the power is turned on, and after the tubes warm up the unit is ready to operate.

In factory assembled combinations the short wave unit is already properly connected to the broadcast receiver. It is always advisable to check over this wiring, however, and see that all connections are properly and securely made.

The three wires from the rear-center of the unit are to be connected as follows:

BLACK The black wire is to be connected to the ground post of the long wave receiver. The actual ground wire is attached to the GND post of the short wave unit and left there permanently.

WHITE: The white wire is to be connected to the antenna post of the long wave receiver. The actual antenna, or aerial, is attached to the ANT post of the short wave unit and left there permanently.

RED: The red wire is to be attached to a source of "B" voltage—either at the long wave chassis or speaker. Any voltage of from 150 to 250 volts is suitable. It should be obtained from some point in the long wave receiver chassis, speaker or filter system, where it will receive fairly good filtering and be relatively free from A. C. hum.

IMPORTANT. As the output of the short wave unit is tuned to a definite frequency it is necessary to set the dial of the long wave receiver at this frequency, and leave it there while tuning for short wave stations. It is important that the long wave dial be set exactly at the output frequency of the short wave unit.

This point is approximately 1,000 kilocycles.

If for any reason the output frequency of the short wave unit has shifted it may be retuned as follows. Set long wave dial at 1,000 kilocycles or at mark. Tune in short wave signals. Tune output by means of adjustment screw, until signal is loudest. Use a bakelite screw driver. The output adjusting screw is at right hand end of short wave chassis, facing the rear.

In the event a strong local station at or near 1,000 kilocycles interferes with short wave reception, the long wave dial may be moved slightly to right or left of 1,000 kilocycle mark, and the output retuned, as above, to ob-

tain greatest short wave output at this newly selected frequency. Move long wave dial off 1,000 K. C. only a few kilocycles at a time, returning the short wave output each time, until the interference is eliminated.

Should the short wave output adjustment be far out of tune, a simple method of resetting is to feed the output of a laboratory or service man's oscillator (tuned to 1,000 K. C.) into the grid of the 224 tube of the short wave unit (while operating) and with long wave receiver also set at 1,000 K. C. (previously set by means of same oscillator, for accuracy). The short wave output adjustment screw may now be turned until maximum oscillator signal is heard, or an output meter, on long wave set, indicates maximum.

PARTS LIST
MODELS 53 & 54-A

1-4-450	Coil, oscillator, with leads.....	\$.75
1-6-301	Condenser, oscillator tuning, 200 Mmf.....	3.25
1-3-226	Condenser, tubular, 0.06 mfd.....	.30
1-4-462	Condenser, output adjust, 10-70 Mmf.....	.50
1-1-A474	Condenser, mica, 100 Mmf.....	.30
1-1-3154	Dial lamp, 2½ volt.....	.30
1-2-7134	Knob, large, wood20
2-2-7134	Knob, small, wood18
1-1-F531	Post, ant10
1-1-F530	Post, gnd10
1-2-F529	Post, bakelite insulating strip.....	.05
1-1-F550	Post, insulating washer.....	.01
2-1-4173	Resistor, 1 watt, 10,000 ohm.....	.25
1-1-4173	Resistor, graphite, 10,000 ohm.....	.25
1-1-7366	Resistor, graphite, 25,000 ohm.....	.25
1-1-4224	Resistor, graphite, 50,000 ohm.....	.25
1-2-172	Resistor, 400 ohm25
1-7-103	Shield, output coil, with bolts.....	.15
2-3-514	Socket, 22418
2-4-515	Socket, 22718
1-8-201	Transformer, 60 cycle.....	2.00
2-8-201	Transformer, 25 cycle.....	3.30

ADDITIONAL PARTS
MODEL 53

1-2-253	Coil, output	1.00
1-6-122	Dial, complete, with scale.....	1.00
1-3-468	Switch, 3 point, tap.....	.50
1-3-471	Switch, A C, and LW-SW.....	.65

MODEL 54 "Globe Trotter"
Schematic, Chassis
Data

COLIN B. KENNEDY CORP.

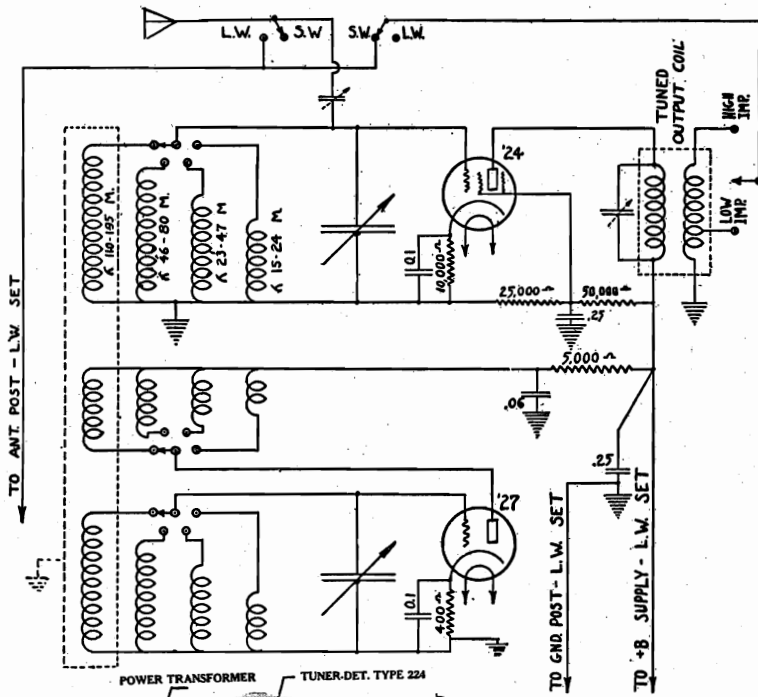

When testing the short wave unit at the factory, it is adjusted for use with an average antenna. Improved results may sometimes be obtained by re-adjusting to the antenna actually used. The procedure for this adjustment is as follows:

Almost exactly in the center of the back of the short wave unit is an adjustment screw which can be operated through a hole provided for it. This screw should be turned with a bakelite screw driver, which most service men carry. A metal screw driver will disturb the adjustment.

Set the switch on the position marked "15-25 meters"—tune in a station (music or code) at about 50 on the right-hand dial. Then adjust the screw described above, until the left-hand dial also reads approximately 50 when properly tuned in. This adjustment then holds for all wave bands.

The BLACK wire is connected to the "ground" binding post of the long wave set. The RED wire is connected to the negative side of the speaker field coil (dynamic speaker), to the speaker wire or connection carrying a filtered "B" voltage supply, or, inside the chassis, to the positive end of the voltage divider resistor.

If difficulty is had in getting the unit to operate when initially hooked up, and the "B" source is suspected, 90 to 135 volts of "B" batteries may temporarily be tried. The red wire goes to the "B" +, the black wire to the long wave receiver ground post as before, and the "B" - to the same ground post.

Any source of "B" voltage from 150 to 250-volts is suitable. It should be obtained from some point in the long wave receiver speaker or filter system, where it will receive fairly good filtering and be relatively free from hum. A lower voltage, well filtered, is more to be desired than a higher voltage with a large proportion of A.C. modulation.

Obtaining this plate supply is very simple on many receivers, such as the Kennedy models 210, 310, 220, 320, 1030, 632, 426, 526, 726, and 826. In these cases the B supply may be taken from the tip-jack terminating the black speaker wire. In Kennedy models 42, 50 and 52 it may be obtained at the speaker terminal panel from the side of the field winding which is common with the speaker transformer primary.

The output of the short wave unit is tuned. It is set, at the factory, to tune to approximately 1525 kilocycles. Naturally, the long wave receiver dial must be set at this point for short wave reception, and left there.

In the event the long wave receiver will not tune past 1500 kilocycles, or a strong local broadcast station interferes at that point, the output frequency tuning may be altered slightly to avoid the difficulty. An adjusting screw for this tuning may be reached through a hole in the rear of the chassis. It is located near the impedance adjusting wire and binding posts, and is to be adjusted with a bakelite screw driver, as a metal tool will upset the adjustment.

It will be noted, facing the rear of the chassis, that on the left hand side a wire has been brought out which may be connected to either one of two small binding posts near the end of the base. The purpose of this is to adjust the output impedance of the unit to that of the antenna input circuit of the receiver it is to be used with. The Kennedy models named above have high impedance antenna circuits and therefore require this wire to be on the upper binding post. In doubtful cases this wire may be tried first on one and then on the other, with unit operating, and permanently left where best results are obtained. These connections are indicated on the accompanying illustration.

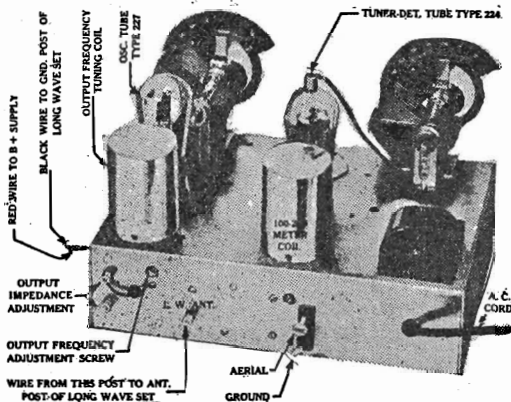
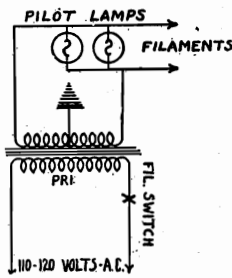
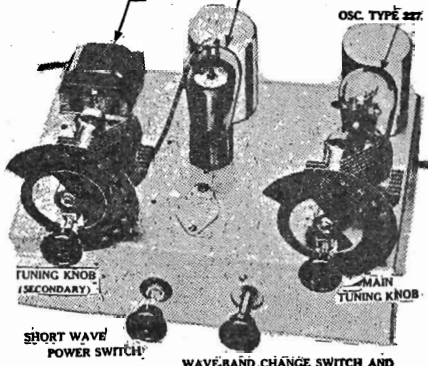

COLIN B. KENNEDY CORP.

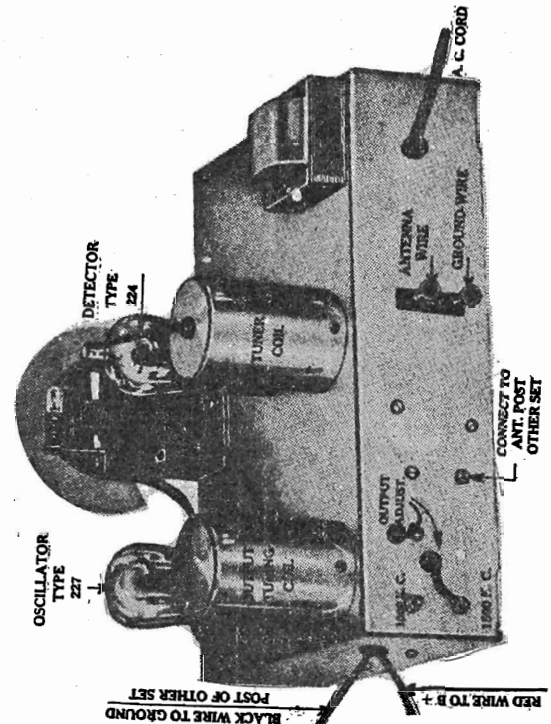
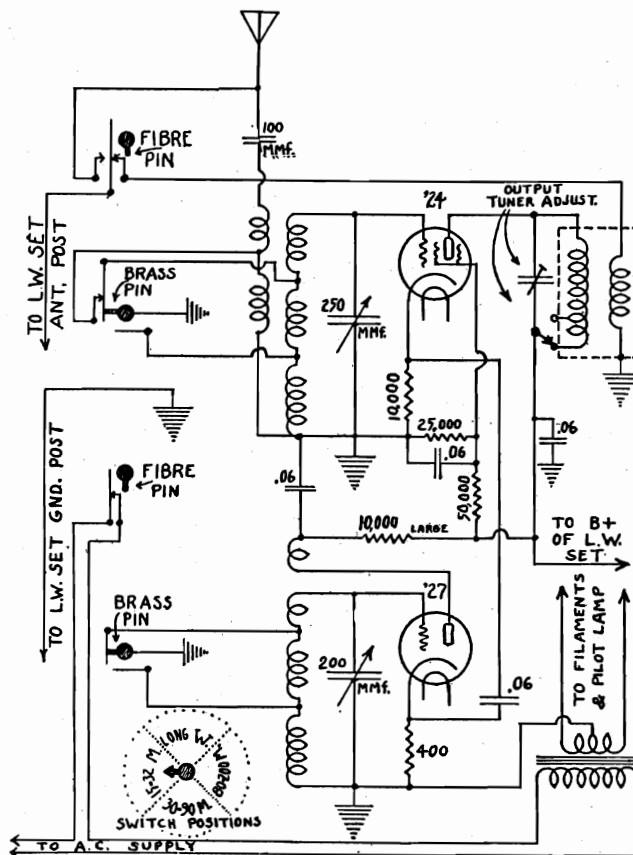
MODEL 54-A
Schematic, Chassis
Data

THE KENNEDY Model 54-A short wave unit operates on the superheterodyne principle, and is commonly called a converter or adapter.

A four-position rotary cam switch changes all connections to any one of three short wave band circuits or to long wave position. This switch makes the proper power and antenna connections, turning off the short wave unit and connecting the antenna directly to the broadcast receiver when in the long wave position. When switched to any one of the short wave bands, the tubes of the short wave unit are supplied with power, and antenna and output connections are made. The short wave unit is, naturally, not used for long wave broadcast reception.

In factory assembled combinations the short wave unit is already properly connected to the broadcast receiver. It is always advisable to check over this wiring, however, and see that all connections are properly and securely made.

The two wires from the left side (facing rear) are to be connected as follows:

BLACK: The black wire is to be connected to the ground post of the long wave receiver. The actual ground wire attached to the GND post of the short wave unit and left there permanently.

RED: The red wire is to be attached to a source of "B" voltage—either at the long wave chassis or speaker. Any voltage of from 150 to 250 volts is suitable. It should be obtained from some point in the long wave receiver chassis, speaker or filter system, where it will receive fairly good filtering and be relatively free from A. C. hum.

A wire, as short as practical, must be connected from the binding post at left-center (facing rear) of unit to the antenna post of the broadcast chassis. The actual antenna, or aerial, is attached to the ANT post of the short wave unit and left there permanently.

For Calibration Scale refer to Model 53-SW

MODEL 56
Schematic
Voltage

COLIN B. KENNEDY CORP.

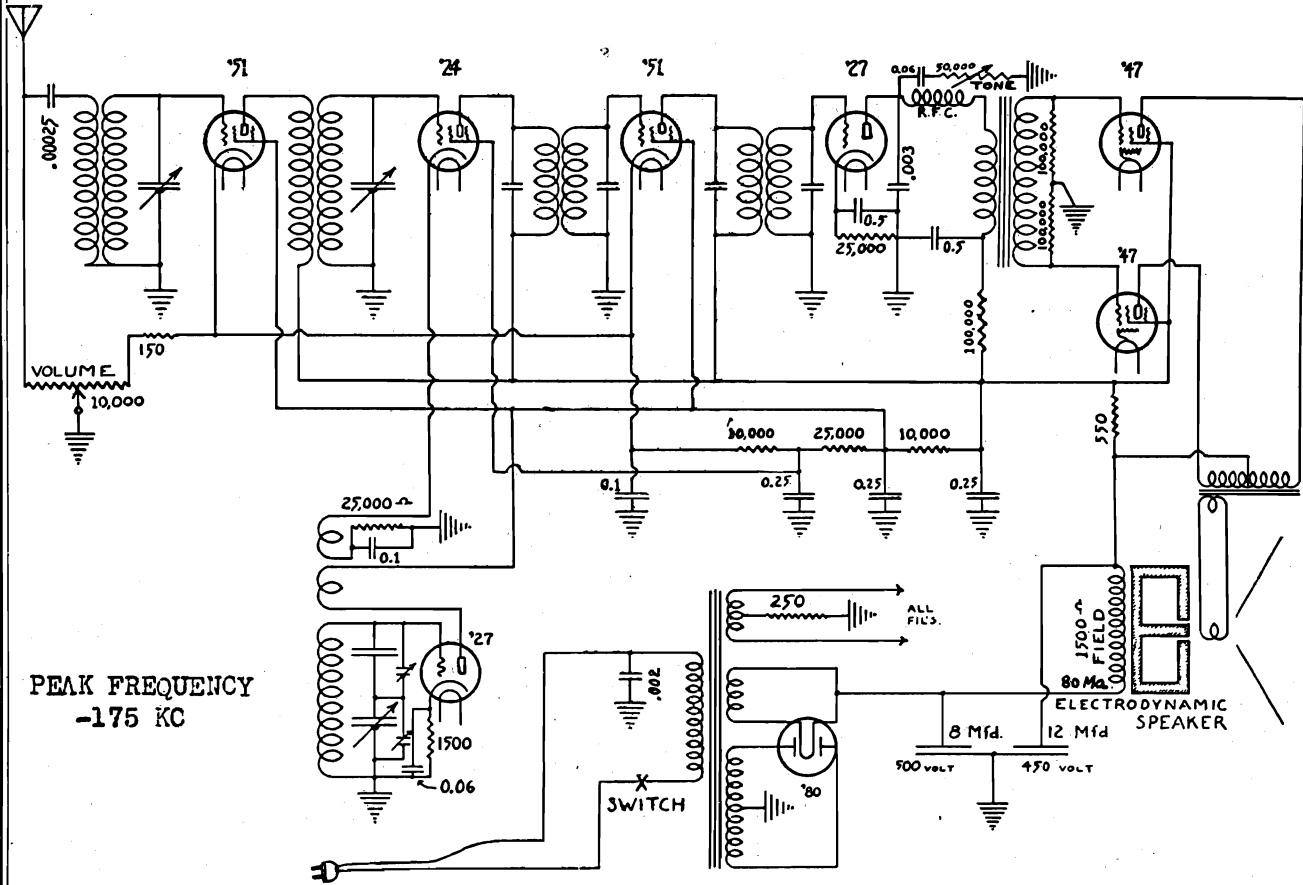

PEAK FREQUENCY
-175 KC

Model 56 (1931)

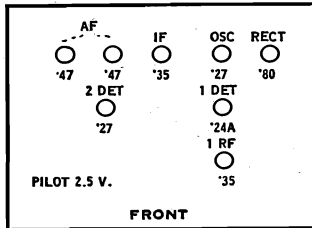

Purpose	Type	Fil./A.C.	Plate	Screen	Bias
Radio Frequency	511	2.35	208	98	3 to 30
1st Detector	224	2.35	208	30	5
Oscillator	227	2.35	90	10	10
Intermediate Freq.	511	2.35	208	98	3 to 30
2nd Detector	227	2.35	120	16	16
Power Tubes	247	2.35	220	208	14
Rectifier	280	4.90			

Volume control full on except for R F and I. F bias extremes. Line voltage 115
Plate, screen and bias voltages measured from ground or chassis to respective terminals.

Resistors

- 117366 Resistor 25,000-ohm graphite
- 114173 Resistor 10,000-ohm graphite
- 114175 Resistor 1,500-ohm graphite
- 12158 Resistor 500-ohm vitreous
- 26406 Resistor 10,000-ohm variable and 150 ohm fixed, volume, with switch
- 25369 Resistor 50,000-ohm variable

Coils

- 11610 Set of three matched coils

Condensers

- 113303 Condenser 1/2 and 1/2 mfd.
- 13417 Condenser 1/4, 1/4 and 1/4 mfd. 300-volt tubular
- 13306 Condenser .1 mfd tubular
- 13226 Condenser .06 tubular 200-volt
- 14306 Condenser .003 mica
- 113305 Condenser .00025 mica
- 16302 Condenser 8 mfd 500-volt
- 17302 Condenser 12 mfd 430-volt

For Technical Data refer to Model 52

MODEL 62
Chassis
Alignment Data

COLIN B. KENNEDY CORP.

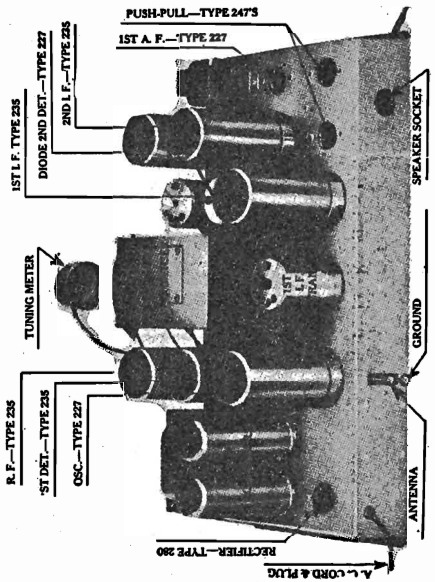
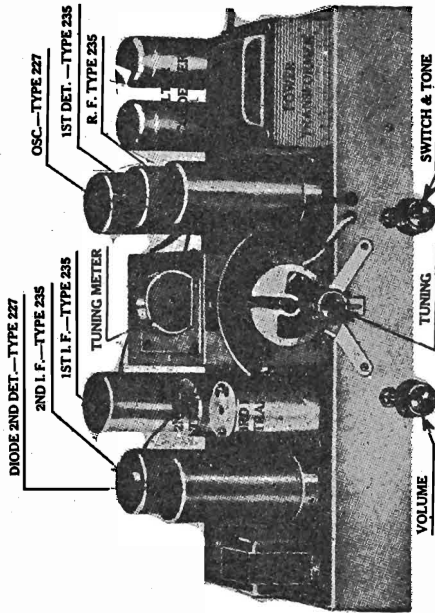

Alignment

Before aligning or testing alignment of tuned circuits, it is desirable to "short out" the automatic volume control action. This is done by grounding the grid return wire of the first three tubes at some point between the 10,000 ohm and 100,000 ohm grid return filter resistors. It will be noted that the low ends of the detector coil and 1st I. F. coil secondaries are connected to this wire. The antenna coil is also connected, but through a 10,000 ohm filtering resistor.

In aligning, it is first desirable to see that the intermediate frequency transformers are properly set. This is most readily accomplished by using an output meter and an accurate source of 175 kilocycle radio frequency, such as an oscillator. The accuracy of this oscillator may be checked by tuning a radio set to a station on 700 kilocycles and placing the oscillator near the antenna. A harmonic of the 175 kilocycle oscillator will "zero beat" with the station if the oscillator is correct. Other "harmonic" points may also be tried.

Remove the grid clip from the top of the first detector tube and fasten a short length of wire to the grid terminal of this tube. Lay this wire sufficiently near the 175 K. C. oscillator to note the energy from it in the output meter. With the oscillator set on exactly 175 K. C., adjust the trimmers in the tops of the I. F. transformer shields for maximum reading of the output meter. If the meter tends to read "off scale," move oscillator farther from set and wire, thereby reducing input energy. If these I. F. transformers are badly out of alignment, it may be necessary to place the "pick up" wire on the grid of the 1st I. F. tube and adjust the second transformer alone, at first, then moving wire to detector grid and proceed as above. It will be noted that the 2nd and 3rd I. F. transformers have but one adjustment, while the first has two.

The tuning condenser may be adjusted for alignment or "tracking" of the tuned circuits by a similar method

except that an oscillator covering the broadcast band should be used. The output meter is used as before. The energy from the oscillator, in this case, is coupled weakly into the antenna circuit—a simple means being to place the oscillator near the antenna wire.

The receiver and oscillator are first tuned to approximately 1,500 kilocycles, and by watching the output indicator, the three condenser trimmers (reached through three holes in top-right of condenser shield, or, in some cases, through removable plate) are adjusted for maximum output. These three trimmers must then be left untouched for all further aligning.

The next step is to tune both receiver and oscillator to some point near 550 kilocycles. Here, the alignment is made by adjusting the "padding" condenser (through hole in rear of condenser shield) for maximum response. If necessary to adjust the two R. F. condenser sections, it may be accomplished by bending the condenser end plates. If found necessary to align at other than the ends of the "band," it may be done by bending the slotted end plate of the condenser rotors. Alignment of the two ends of the scale is usually quite sufficient.

IMPORTANT: It is desirable to move the dial back and forth across the signal while making the above alignments. This is particularly necessary when altering any capacities connected with the oscillator circuit. An insulated or bakelite screw driver (containing little, if any, metal) is advised for use in adjusting "trimmer" or "padding condensers."

Circuit correction. The bias for the oscillator tube, on later models, will be found to be obtained from the 1st detector cathode resistor instead of the 1,500 ohm self bias resistor as indicated. In this case, the 1st detector bias resistor has been changed from 3,000 ohms, as shown, to 1,000 ohms. The self bias resistor of the 2nd I. F. tube will be found changed to 3,000 ohms.

The automatic volume control functions with the diode second detector. The rectified radio frequency flows from the grid and plate (which are joined) to cathode and ground. It returns through the manual volume control and the two 100,000 ohm resistors to the secondary of the last I. F. transformer, and back to the plate and grid, completing the rectifying circuit. No current flows in this circuit until a carrier wave is tuned in. With no current flowing, the bias for the R. F. and 1st I. F. tubes is obtained in the 300 ohm resistor in series with their two cathodes. The biases of the 1st detector and 2nd I. F. tubes are obtained by individual cathode resistors. When current flows in the diode circuit, points along the resistance path from volume control ground to secondary coil are successively more and more negative with respect to ground due to the drop in these resistors. They are naturally more negative when more current flows in this circuit. Advantage is taken of this to provide almost perfect automatic bias control for the first three tubes by returning the grid circuits of these tubes to a determined point on these resistors. Thus, the negative voltage developed by the diode circuit is added to the fixed bias already provided for these tubes. Stronger signals increase this added bias; weaker signals reduce the added bias; and the result in the over-all response is uniformity of volume level. As the volume control is rotated toward minimum or "OFF," more resistance is added to the automatic circuit, increasing its action, and at the same time operates in the audio system by tending to short out the signal to the first audio tube grid.

In all other respects, the circuit is entirely conventional, and may be tested in the regular ways with standard equipment.

Continuity of circuit and coils may be tested with a battery, meter and pair of test leads. If necessary to replace a coil, it is advisable to replace the entire set of three with a new correctly matched set.

MODEL 64
Alignment
Socket

COLIN B. KENNEDY CORP.

station if the oscillator is correct. Other "harmonic" points may also be tried. With the receiver switched to short wave position, remove the grid clip from the top of the S.W. mixer tube and fasten a short length of wire to the grid terminal of this tube. Lay this wire sufficiently near the 175 K.C. oscillator to note the energy from it in the output meter. With the oscillator set on exactly 175 K.C., adjust the trimmers in the tops of the I.F. transformer shields for maximum reading of the output meter. If the meter tends to read "off scale," move oscillator farther from set and wire, thereby reducing input energy. If these I.F. transformers are badly out of alignment, it may be necessary to place the "pick up" wire on the grid of the long wave mixer and adjust the last two transformers alone, at first, then moving wire back to S.W. mixer and proceed as before. It will be noted that the first I.F. transformer has but one adjustment.

The tuning condenser may be adjusted for alignment or "tracking" of the tuned circuits by a similar method except that an oscillator covering the broadcast band should be used. The output meter is used as before. The energy from the oscillator, in this case, is coupled weakly into the antenna circuit - a simple means being to place the oscillator near the antenna wire. The receiver and oscillator are first tuned to approximately 1,500 kilocycles, and by watching the output indicator, the three condenser trimmers, reached through the removable plate, are adjusted for maximum output. These three trimmers must then be left untouched for all further aligning. The next step is to tune both receiver and oscillator to some point near 550 kilocycles. Here, the alignment is made by adjusting the "padding" condenser for maximum response. It may be reached through hole in rear center of chassis base.

If necessary to adjust the two R.F. condenser sections, it may be accomplished by bending the condenser end plates. If found necessary to align at other than the ends of the "band", it may be done by bending the slotted end plate of the condenser rotors. Alignment of the two ends of the scale is usually quite sufficient.

IMPORTANT: It is desirable to move the dial back and forth across the signal while making the above alignments. This is particularly necessary when altering any capacities connected with the oscillator circuit.

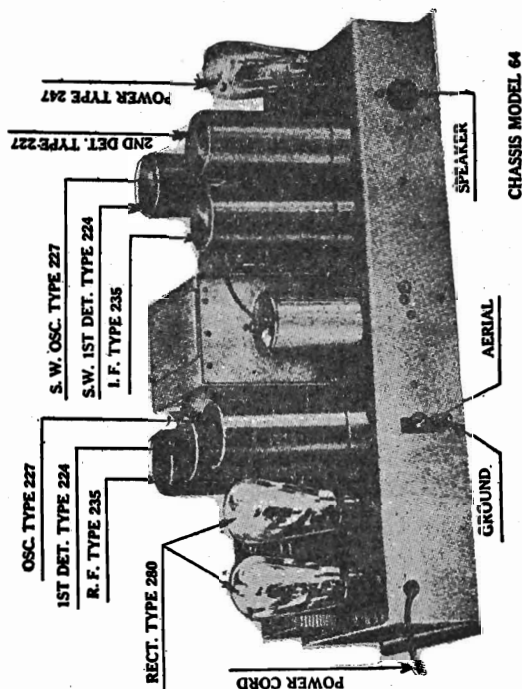
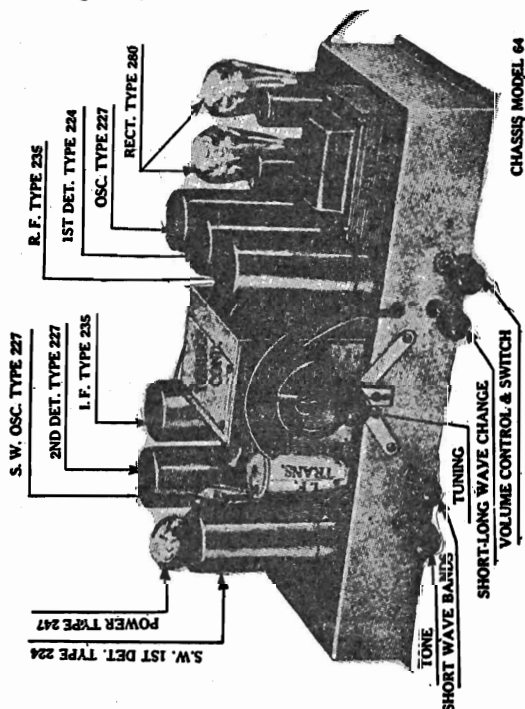

KOLSTER RADIO, INC.

MODEL K-45

Voltage, Alignment Data
Power Transformer Assembly

It is sometimes noticeable that the Condenser Gang does not respond rapidly enough when a selector button is pressed. This is caused by a slow motor and the brake adjustment should be loosened. The method of adjusting the friction brake is as follows: (1) Unloosen the machine screw holding the slotted brake shoe to the motor. (2) Adjust the friction of the brake shoe by varying the pressure applied to the fibre washer fastened to the motor armature. (3) The brake is adjusted properly when the maximum speed is obtained without the condenser gang carrying by the station corresponding to the selector button pressed. (4) When the proper adjustment has been made, securely tighten the brake locking screw. Ordinarily, no adjustment need be made of this device, as it is properly set in manufacture or if proper line voltage is used.

The motor clutch device is for the purpose of mechanically disengaging the drive motor armature from the tuning condenser simultaneously with the opening of the motor circuit. This electrically-operated device is necessary so as to eliminate the possibility of the inertia of the motor armature, when the motor circuit is open, from turning the tuning condenser past the pre-determined setting of the selector brush. Make certain that the position of the line voltage switches in both the power pack and relay unit are set to correspond with the existing AC line voltage.

If it is desired, the remote cable may be disconnected from the receiver by removing the nuts holding the terminal card to the motor unit and relay box. This will in no way interfere with the operation of the set at the local position.

Four adjustable trimmer condensers are provided on top of the main gang condenser to compensate for small capacitive variations in the tuning circuits. This condition is made noticeable by the receiver becoming insensitive.

If it appears a certainty that the tuning circuits are not balanced, a simple method for readjusting is as follows:

- 1—Tune in a signal, preferably at the low end of the dial, and adjust the volume control for a moderate signal intensity.
- 2—Adjust with a short bakelite screwdriver the four compensating condensers successively, from the detector to the first RF stage, for the greatest signal intensity.
- 3—The various adjustments can now be checked at medium and high points on the dial, making slight variations if it is found necessary.

Bending the end plates of the variable tuning condensers in order to align the gang should only be resorted to if the trimmers are not sufficiently effective. This method will only be necessary in extreme cases where the condenser gang has been subjected to abuse or severe handling.

Should it ever be necessary to replace the cone assembly the proper procedure is as follows:

- 1—Place the speaker flat on the felt ring.
- 2—Unsolder the two leads coming from the output transformer to the voice coil.
- 3—Remove the four long bolts from the back of the field coil housing.
- 4—Lift the field coil and assembly straight upwards and away from the cone assembly to which remains the end plate.

To recenter a voice coil the above procedure is followed, and with the cone assembly remaining flat on the felt ring there will be found the heads of these small machine screws close to the opening in the end plate for the voice coil. Loosen these screws and shift the cone assembly until the voice coil is concentric with the hole in the end plate. Retighten the screws just loosened and reassemble the unit in the reverse manner in which it was disassembled.

Care must be taken against damaging the voice coil against the pole piece and also the four long assembly bolts must be drawn up as tightly as possible.

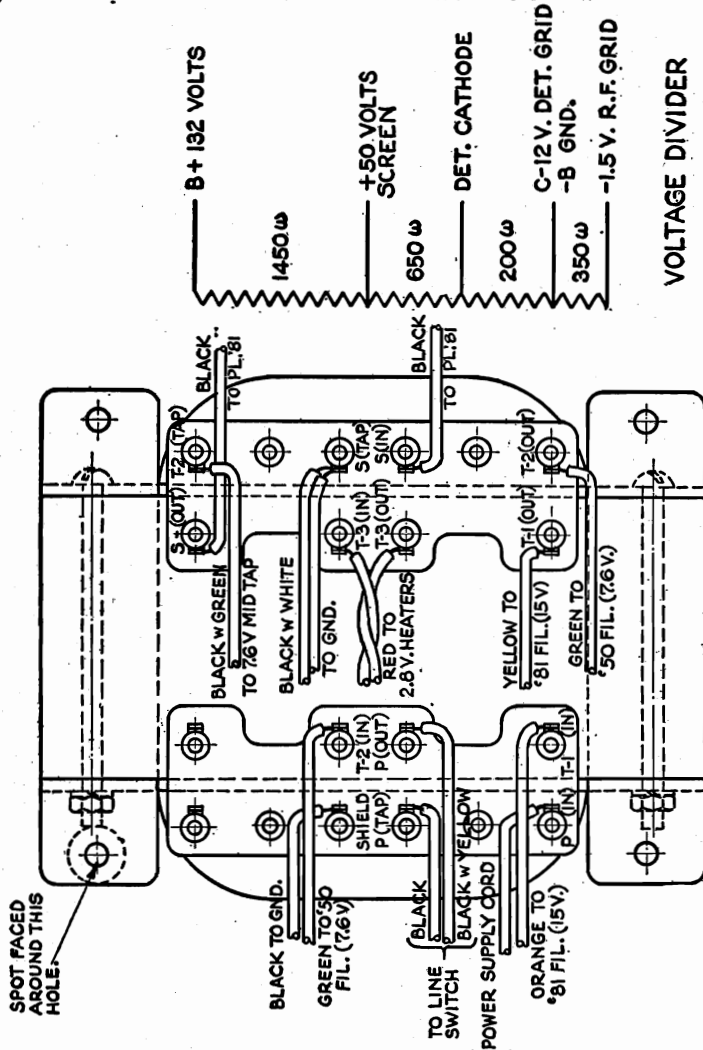

MODELS K-60, K-62, K-70, K-72

K-80, K-82, K-90, K-92

Condenser & Resistor Data

KOLSTER RADIO, INC.

MODELS K-60—K-62

- Condenser, Electrolytic, 475 volts, 8 mfd. (C6-C7)
- Condenser, Electrolytic, 430 volts, 8 mfd. (C8)
- Condenser, fixed, Mica, .000725 mfd. (Yellow) (C2)
- Condenser, fixed, Mica, .0002 mfd. (Gray) (BC-4)
- Condenser, fixed, Mica, .001 mfd. (Orange) (C1)
- Condenser, fixed, Mica, .0015 mfd. (Blue) (SC-1)
- Condenser, fixed, Mica, .003 mfd. (Pink) (SC-2)
- Condenser, fixed, paper, .025 mfd. (200 volts) (C4)
- Condenser, fixed, paper, .1 mfd. (200 volts) (BC-6)
- Condenser, fixed, paper, .1 mfd. (400 volts) (C-5)
- Condenser, variable, 3 gang, comp. (VC-1, VC-2, VC-3)
- Condenser block (4 sections) (BC-1, BC-2, BC-3, C3)
- Resistor, fixed, carbon, 200 ohms (Body red, tip black, dot brown) (R5)
- Resistor, fixed, carbon, 10000 ohms (Body brown, tip black, dot orange) (R2)
- Resistor, fixed, carbon, 25000 ohms (Body red, tip green, dot orange) (R6)
- Resistor, fixed, carbon, 100000 ohms (Body brown, tip black, dot yellow) (R3)
- Resistor, fixed, carbon, .25 megohms (Body red, tip green, dot yellow) (R4, R7, R8, R9, R10)
- Resistor, fixed, carbon, 1 megohm (Body brown, tip black, dot green) (R1)
- Resistor, vitreous, tapped (R11, R12, R13, R14)

MODELS K-70—K-72

- Condenser, Electrolytic, 475 volts, 8 mfd. (C6-C7)
- Condenser, Electrolytic, 430 volts, 8 mfd. (C8)
- Condenser, fixed, Mica, .000725 mfd. (Yellow) (C2)
- Condenser, fixed, Mica, .0002 mfd. (Gray) (BC-5)
- Condenser, fixed, Mica, .0005 mfd. (Red) (C4)
- Condenser, fixed, Mica, .001 mfd. (Orange) (C1)
- Condenser, fixed, Mica, .0015 mfd. (Blue) (SC-1)
- Condenser, fixed, Mica, .003 mfd. (Pink) (SC-2)
- Condenser, fixed, paper, .025 mfd. (200 volts) (C-10)
- Condenser, fixed, paper, 0.1 mfd. (200 volts) (C3, C-9, BC-1, BC-4, BC-7, BC-8)
- Condenser, fixed, paper, 0.1 mfd. (400 volts) (C5), BC-11
- Condenser, fixed, paper, 1.0 mfd. (K-72) (C11)
- Condenser, variable, 3 gang, comp. (VC-1, VC-2, VC-3)
- Condenser block (5 sections) (BC-2, BC-3, BC-6, BC-9, BC-10)
- Resistor, fixed, carbon, 200 ohms (Body red, tip black, dot brown) (R2)
- Resistor, fixed, carbon, 5000 ohms (Body green, tip black, dot red) (R9, R21)
- Resistor, fixed, carbon, 10000 ohms (Body brown, tip black, dot orange) (R3)
- Resistor, fixed, carbon, 20000 ohms (Body red, tip black, dot orange) (R11)
- Resistor, fixed, carbon, 25000 ohms (Body red, tip green, dot orange) (R8, R16)
- Resistor, fixed, carbon, 100000 ohms (Body brown, tip black, dot yellow) (R4)
- Resistor, fixed, carbon, .25 megohms (Body red, tip green, dot yellow) (R1, R5, R17, R18, R19, R20)
- Resistor, fixed, carbon, 2 megohms (Body red, tip black, dot green) (R6, R7)
- Resistor, vitreous, tapped (R12, R13, R14, R15)

MODELS K-80—K-82

- Condenser, Electrolytic, 475 V. (C6-C7)
- Condenser, Electrolytic, 430 V. (C8)
- Condenser, fixed, Mica, .000725 Mfd. (Yellow) (C2)
- Condenser, fixed, Mica, .0005 Mfd. (Red) (SC-1, C4)
- Condenser, fixed, Mica, .001 Mfd. (Orange) (C1, BC-6)
- Condenser, fixed, Mica, .002 Mfd. (Green) (SC-2, BC-9)
- Condenser, fixed, paper, .025 Mfd. (200 volts) (C9)
- Condenser, fixed, paper, .1 Mfd. (200 volts) (BC-1, BC-5, C3)
- Condenser, fixed, paper, .1 Mfd. (400 volts) (C5) (BC-10)
- Condenser, fixed, paper, 1 Mfd. (200 volts) (K-82) (C10)
- Condenser, variable, 3 gang comp. (VC-1, VC-2, VC3)
- Condenser block (5 sections) (BC-2, BC-3, BC-4, BC-7, BC-8)
- Resistor, fixed, carbon, 200 ohms (Body red, tip black, dot brown) (R2)
- Resistor, fixed, carbon, 5000 ohms (Body green, tip black, dot red) (R18) (K-82)
- Resistor, fixed, carbon, 10000 ohms (Body brown, tip black, dot orange) (R3, R17)
- Resistor, fixed, carbon, 20000 ohms (Body red, tip black, dot orange) (R9)
- Resistor, fixed, carbon, 25000 ohms (Body red, tip green, dot orange) (R13, R14)
- Resistor, fixed, carbon, 50000 ohms (Body green, tip black, dot orange) (R15, R16)
- Resistor, fixed, carbon, 100000 ohms (Body brown, tip black, dot yellow) (R4)
- Resistor, fixed, carbon, .25 megohms (Body red, tip green, dot yellow) (R1)
- Resistor, fixed, carbon, 2 megohms (Body red, tip black, dot green) (R11, R12)
- Resistor, vitreous, tapped (R5, R6, R7, R8)

MODELS K-90—K-92

- Condenser, Electrolytic, 475 V. (C6-C7)
- Condenser, Electrolytic, 430 V. (C8)
- Condenser, fixed, Mica, .000725 Mfd. (Yellow) (C2)
- Condenser, fixed, Mica, .0005 Mfd. (Red) (SC-1, C4)
- Condenser, fixed, Mica, .001 Mfd. (Orange) (BC-6, C1)
- Condenser, fixed, Mica, .002 Mfd. (Green) (SC-2, BC-9)
- Condenser, fixed, paper, .025 Mfd. (200 volts) (C9-C10)
- Condenser, fixed, paper, .1 Mfd. (200 volts) (BC-1, BC-5, C3)
- Condenser, fixed, paper, .1 Mfd. (400 volts) (C5)
- Condenser, fixed, paper, 1 Mfd. (200 volts) K-92 (C11)
- Condenser, variable, 4 gang, comp. (VC-1, VC-2, VC-3, VC-4)
- Condenser block (5 sections) (BC-2, BC-3, BC-4, BC-7, BC-8)
- Resistor fixed, carbon, 200 ohms (Body red, tip black, dot brown) (R2)
- Resistor, fixed, carbon, 5000 ohms (Body green, tip black, dot red) (R19)
- Resistor, fixed, carbon, 8000 ohms (Body gray, tip black, dot red) (R11)
- Resistor, fixed, carbon, 10000 ohms (Body brown, tip black, dot orange) (R3-R20)
- Resistor, fixed, carbon, 12000 ohms (Body brown, tip red, dot orange) (R-10)
- Resistor, fixed, carbon, 25000 ohms (Body red, tip green, dot orange) (R13-R14)
- Resistor, fixed, carbon, 50000 ohms (Body green, tip black, dot orange) (R15-R16-R19)
- Resistor, fixed, carbon, 100000 ohms (Body brown, tip black, dot yellow) (R4)
- Resistor, fixed, carbon, .25 megohms (Body red, tip green, dot yellow) (R1-R5)
- Resistor, fixed, carbon, 1 megohm (Body brown, tip black, dot green) (R17-R18)
- Resistor, vitreous, tapped (R6-R7-R8-R9)

Model K 80,82 sets as originally manufactured employed 15,000 ohm volume control unit, (Stamped No. 62018). To improve volume control action, this unit has been replaced with 15,000 ohm potentiometer, (Stamped No. 62025).

In addition to replacing the volume control unit as just described, a 1,000 ohm fixed resistor, Part No. 6569-15, is installed in the Cathode circuit of the automatic volume control tube. This should be connected between the end of the volume control unit (R-10) and the 20,000 ohm resistor (R-9).

MODELS K-60, K-62, K-70, K-72
K-80, K-82, K-90, K-92
Condenser Adjustments, Data

KOLSTER RADIO, INC.

Models K-60—K-62—K-70—K-72—K-80—K-82—K-90—K-92

**R.F. TUNING AND OSCILLATOR TRIMMING CONDENSER
ADJUSTMENTS**

Located on the front of the gang condenser are three trimmer condensers (TC-1-2-3) which are provided for aligning the R.F. circuits. The 600 K.C. trimmer condenser (OC-1) for the OSCILLATOR will be found on the right hand top of the chassis base directly in front of the '80 socket and opposite the coil shield. Poor tone, lack of sensitivity and selectivity, or complete inoperation of the receiver may be caused by these condensers being out of adjustment.

(a) Place the oscillator in operation at exactly 1400 K.C. and couple it to the antenna. Connect the output device in accordance with the type used. Tune in the oscillator signal and adjust the coupling between the oscillator and the antenna lead of the set, or increase the volume control setting until a deflection is obtained in the output meter.

(b) With an insulated screw driver adjust each of the trimmer condensers mounted on the gang condenser frame until a maximum deflection is obtained in the output meter. If the pointer goes off scale reduce the coupling or the volume control.

(c) Set the oscillator now at 600 K.C. Tune in this signal with the receiver and adjust coupling or volume control for a deflection in the output meter. Now adjust the oscillator 600 K.C. trimmer condenser (OC-1) until a maximum deflection is obtained. In making this adjustment it is advisable to rock the tuning condenser back and forth a few degrees each side of the normal position.

(d) Change the setting of the oscillator back to 1400 K.C. and readjust the three trimmer condensers.

If attention is given to the adjustments the R.F. and oscillator circuits will be properly aligned and satisfactory results should be obtained. If not the next step is to adjust the I.F. circuits.

I.F. CIRCUIT ADJUSTMENTS

A single intermediate frequency stage with two transformers is used in band-pass arrangement. Each transformer has both the primary and secondary windings tuned accurately for 175 K.C.

To adjust these circuits proceed as follows:

(a) Set the previously mentioned oscillator at 175 K.C.

(b) Connect the output device.

(c) Remove the oscillator tube, which is the type '27 adjacent to the type '80, and make a good ground connection to the chassis.

(d) Connect the output of the oscillator to the Control Grid cap of the first detector, which is the type '24 tube.

(e) Adjust the oscillator output or the receivers volume control until a deflection is obtained in the output device.

(f) Place the chassis on end and the adjusting screws for the I.F. transformer condensers (IC-1-2-3-4) will be found through holes in the under side of the base after the bottom shield has been removed.

(g) Adjust the secondary and primary of the second and first I.F. transformers in the order just mentioned until a maximum deflection is obtained in the output meter. Make these adjustments the second time to insure proper aligning. It is now advisable to recheck the R.F. and oscillator condensers again.

LINE VOLTAGE VARIATIONS Models K-60—K-62 and Models K-70, K-72

These models were tested on 115 volts, and are therefore suitable for operation on line voltages ranging from 110 to 120 volts. Should lower line voltages be encountered it will be necessary to remove the chassis from the cabinet and unsolder the BLUE lead, which comes from the under side of the power transformer and is connected to one side of the line switch mounted on the rear of the volume control. In its place solder the GREEN lead, taping the end of the Blue lead just removed so that it will not short against other leads in the chassis. In locations where the line voltages exceed 120 volts, a suitable resistor will be necessary to reduce the voltage applied to the correct value.

CAUTION

**NEVER TURN ON THE POWER TO THE SET WHEN THE
SPEAKER IS DISCONNECTED**

KOLSTER RADIO, INC.

MODEL K-60, K-62
Voltage, Test Data

From Chassis To

Correct

Incorrect

All tubes removed from sockets and AC plug removed from power supply. Speaker connected. Volume control maximum unless otherwise stated.

From Chassis To

Correct

Incorrect

Aerial
RF Control Grid

1.55 ohms
1,000,000 ohms

Includes one rf wdg TC- rf Cg-Y

Output Transformer Secondary Only
Voice Coil only

0.3 ohm
3 ohms

RF Control Grid and first tuning condenser stator

6.4 ohms

BC- rf K-Y (.25 mfd)

BC- between power transformer primary and chassis (.1 mfd)

RF Cathode (V.C.Max)

200 ohms

EC- rf Sg-Y (.25 mfd)

Voice Coil and Secondary

0.273 ohm

RF Screen Grid

2,653 ohms

BC- across 1 meg unit

Across AC Plug (110-120 V)

1.9 ohm

RF Plate

6,679 ohms

TC- across first rf wdg AC plug to chassis

Across AC Plug (100-110 V)

1.7 ohm

RF Plate to 80 Fil

26 ohms

Notes** Oscillator coil is isolated from oscillator control grid by means of blocking condenser. Oscillator coil only has a resistance of 2.6 ohms.

0 ohm

0 ohm

1 Detector Control Grid

26 ohms

BC across 10,000 ohm S C plug wdg S.9 ohms

See RF Screen

230. 225. 225. 125.* 85. 225.

1 Detector Cathode

10,003.9 ohms

TC- IF Ir Primary .25 meg resistor across primary

Heater Voltage

80. 74. 80. 22.* - .245.

1 Detector Screen Grid

2,653 ohms

TC- if Cg-Y

Control Grid Voltage

3.* 6. 4. 6. - .2

1 Detector Plate

6,703 ohms

See RF Cathode

Screen Grid Voltage

230. 225. 225. 125.* 85. 225.

IF Control Grid

50 ohms

See RF Screen

Plate Voltage

6.0 ma 1.0 7.0 .2 .2

IF Cathode

200 ohms

See RF Cathode

Plate Current

6.0 1.0 7.0 .2 .2

IF Screen Grid

2,653 ohms

See RF Screen

Plate Current

6.0 1.0 7.0 .2 .2

IF Plate

6,703 ohms

See RF Plate

Plate Current

6.0 1.0 7.0 .2 .2

2 Detector Control Grid

50 ohms

TC- 2 D Cg-Y

Rect.

24. 48. per anode

2 Detector Cathode

25,000 ohms

EC- 2 DK-Y (1. mfd)

Indicates incorrect reading due to high resistance in circuit.

225. 653

2 Detector Screen

256,838 ohms

EC- 2 D Sg-Y (.1 mfd)

** Volume control at maximum and tone control in natural position.

225. 838

2 Detector Plate

500,200 ohms

BC 2 DP-2DK BLC- 2 DP-147 Cg

Volume control at maximum and tone control in natural position.

500. 200

Oscillator Control Grid

100,000 ohms

EC- rf Sg-Y

Tone Control Condensers

26 50 50

Oscillator Cathode

0 ohm

EC- '47 Grid fil res-Y

See 2 D Plate

26 50 50

Oscillator Plate

2,656 ohms

See 2 D Plate

See 2 D Plate

26 50 50

'47 Control Grid

500,200 ohms

See 2 D Plate

See 2 D Plate

26 50 50

RF Plate to '47 Screen

26 ohms

1 Detector Plate to '47 Screen

50 ohms

IF Plate to '47 Screen

50 ohms

'47 Screen Grid to '80 Fil

0 ohm

'47 Plate to Chassis

860 ohms

'47 Plate to '80 Filament

650 ohms

'80 Anode to Chassis

1,733 ohms

KOLSTER RADIO, INC.

MODEL K-70, K-72
Test Data
Voltage

From Chassis To	Correct	Incorrect	From Chassis To	Correct	Incorrect
All tubes removed from sockets and AC plug disconnected from power supply Speaker disconnected. Volume control maximum unless otherwise stated.					
Aerial			AVC Plate	2,000,000 ohms	See RF Control Grid See 1 Det Control Grid
RF Control Grid	1.55 ohms		'80 Anode to '80 Anode	166 ohms	TC
RF Control Grid to Stator of first tuning condenser	2,250,000 ohms	TC- rf Cg-Y	'80 Anode to AVC Cathode*	15,483 ohms	FC
RF Cathode	6.4 ohms		'80 Anode to 80 Filament *	53,483 ohms	
RF Screen	200 ohms	BC- rf K-Y (.25 mfd)	Across Filament contacts of speaker plug	830 ohms	
RF Plate	23,000 ohms	BC-Y (1 mfd)	Across Grid- Plate contacts of speaker plug	650 ohms	
RF Plate to '47 Screen	6,026 ohms	BC Osc P-Y	Across Voice Coil only	7.5 ohms	
1 Detector Control Grid	26 ohms	BC- rf P wdg-Y	Across Output Transformer secondary only	0.92 ohm	
1 Detector Cathode	10,003.9 ohms		Across AC Plug (110-120 V)	1.9 ohm	
1 Detector Screen Grid	23,000 ohms	BC across 10,000 ohms	Note- Field coil resistance 830 ohms.		
1 Detector Plate	6,050 ohms	Osc Cplg wdg-3.9 ohms	Output transformer primary 650 ohms		
1 Detector Plate to '47 Screen	50 ohms	See RF Screen	'47 Plate to '47 Screen	650 ohms	
IF Control Grid	2,000,050 ohms	See RF Plate			
IF Control Grid to AVC Plate	50 ohms	TC- if Tr wdg	** Everything as in model 70, except for the following- Speaker Disconnected		
IF Cathode	200 ohms	250,000 ohm resistor	'80 Anode to AVC Cathode	20,483 ohms	
IF Screen Grid	23,000 ohms	TC- if Tr	'80 Anode to '80 Filament	58,483 ohms	
IF Plate	6,050 ohms	TC- if Cg			
IF Plate to '47 Screen	50 ohms	BC- if Cg TC-Y			
2 Detector Control Grid	50 ohms	TC- if Tr sec			
2 Detector Cathode	250,000 ohms	See RF Cathode			
2 Detector Screen	253,000 ohms	See RF Screen			
2 Detector Plate	256,185 ohms	TC- IF Tr pri			
2 Detector Plate to '47 Screen	250,000 ohms	See RF Plate			
'47 Control Grid	502,200 ohms	TC- IF Tr			
'47 Filament	2,000 ohms	TC- 2 D Cg-Y			
'47 Screen	6,000 ohms	BC- 2 D K-Y			
'47 Screen to '80 Fil	0 ohm	BC- 2 D Sg-Y			
AVC Control Grid	2,032,000 ohms	BC- 2 D P- 2 D K			
AVC Control Grid to AVC Cathode	32,000 ohms	BLC- 2 DP-'47 Cg			
AVC Cathode	27,000 ohms	BLC-'47 Cg- 2 DP			
AVC Screen Grid		BC-'47 Cg filter res-Y			
		Tone Control condensers			
		FC			
		See IF Plate			
		CC AVC Cg- if P			

KOLSTER K 70-K 72

Volume control at maximum. Tone control at natural position.

Tube	Control Grid Voltage	Screen Grid Voltage	Cathode Voltage	Plate Voltage	Plate Current
RF	.5*	60.	80.	199.	.25 ma
1 Det	5.	50.	84.	180.	.6
IF	3.	75.	80.	195.	1.
AVC	.25	25.	50.	20.	-
2 Det	4.	24*	80.	100*	.25
Pwr	4. *	260.	80.	235.	35.
Osc.	2.5		80.	80.	5.
Rect.					48. per anode

* Indicates incorrect reading due to high resistance in circuit.

KOLSTER RADIO, INC.

MODEL K-80, K-82
Voltage
Test Data

From Chassis To	Correct	Incorrect	From Chassis To	Correct	Incorrect
All tubes out of receivers and AC plug disconnected from power supply. Speaker disconnected. Volume control maximum unless otherwise stated.					
RF Control Grid	2,250,000 ohms	1.55 ohms	'80 Anode to '80 Anode	166 ohms	TC across filter ohk
RF Control Grid to first tuning condenser stator	6.4 ohms		'80 Anode to AVC Cathode (K-80)	15,483 ohms	FC
RF Cathode	200 ohms		'80 Anode to AVC Cathode (K-82)	20,483 ohms	
RF Screen	7,000 ohms		'80 Anode to '80 Fil (K-80)	33,483 ohms	FC
RF Plate	13,026 ohms		'80 Anode to '80 Fil (K-82)	38,573 ohms	
IF Plate to '47 Screen	26 ohms		Field coil only	830 ohms	
1 Detector Control Grid	26 ohms		Output transformer primary	830 ohms	
1 Detector Cathode	10,003.9 ohms		Output transformer secondary only	0.812 ohm	
1 Detector Screen Grid	7,000 ohms		Voice coil only	8.7 ohms	
1 Detector Plate	13,050 ohms		Oscillator Control Grid	100,000 ohms	
1 Detector Plate to '47 Screen	50 ohms		Oscillator Cathode	0. ohm	
IF Control Grid	2,000,050 ohms		Oscillator Plate	7,003.1 ohms	
IF Control Grid to AVC Plate	50 ohms		Oscillator Plate to RF Screen	3.1 ohms	
IF Cathode	200 ohms				
IF Screen Grid	7,000 ohms				
IF Plate	13,050 ohms				
IF Plate to '47 Screen	50 ohms				
2 Detector Control Grid	50 ohms				
2 Detector Cathode	25,000 ohms				
2 Detector Plate	42,545 ohms				
2 Detector Plate to '47 Screen	29,545 ohms				
'47 Control Grid	59,250 ohms				
'47 Control Grid to Control Grid	112,500 ohms				
'47 Gg to Gg-tone Switch closed	9,100 ohms				
'47 Screen Grid	13,000 ohms				
'47 Screen to '80 Fil.	0 ohm				
AVC Control Grid	2,020,000 ohms				
AVC Cathode	5,000 ohms				
AVC Screen Grid	3,000 ohms				
AVC Plate	2,000,000 ohms				
AVC Filament	3,255 ohms				
CC- AVC Gg-if P					
BC- across 10,000 ohms					
Osc. coil wdg 3.9 ohm					
BC- rf Sg-Y (.25 mfd)					
BC- rf P wdg-Y (1.mfd)					
BC- 2 D AF Tr-2 DK					
FC- 2 RF P wdg-Y-(8mfd)					
TC- if Ir					
See RF Plate					
BC- if wdg- if K					
TC- IF Tr					
See RF Cathode					
See RF Screen					
See RF Plate					
TC- 2 D Gg-Y					
BC- 2 DK-Y (1.mfd)					
BC- 2 DK- 2 DP (.001 mfd)					
BC- AF Tr- 2 DK (1 mfd)					
BC- 2DP-2DK (.001 mfd)					
See RF Plate					
Tone Control Condenser					
Tone Control Condenser					
Tone Switch closed					

Notice.***
In later production of the K-80, a 1000 ohm fixed resistor was added to the cathode circuit of the AVC tube. This must be added to the various values obtained by working between the AVC tube cathode and other points in the receiver.

KOLSTER K 80-K 82

Volume control at maximum. Tone control at natural position.

Tube	Control Grid Voltage	Screen Grid Voltage	Cathode Voltage	Plate Voltage	Plate Current
RF	0.4 *	80.	48.	185.	2.5 ma.
1 Det	5.5	80.	58.	185.	.6
IF	0.2 *	44.	44.	195.	1.0
AVC	0.5	44.	-60.	15.	0.0
2 Det	15.	-	75.	150.	0.6
Pwer	12. *	245.	-	225.	30.
Pwer	12. *	245.	-	225.	30.
Osc.	0. *	-	62.	-	6.0
Rect.					48. per anode in circuit.

* Indicates incorrect reading due to high resistance in circuit.

MODEL F-7
110 Volt D-C.

LANG RADIO CO.

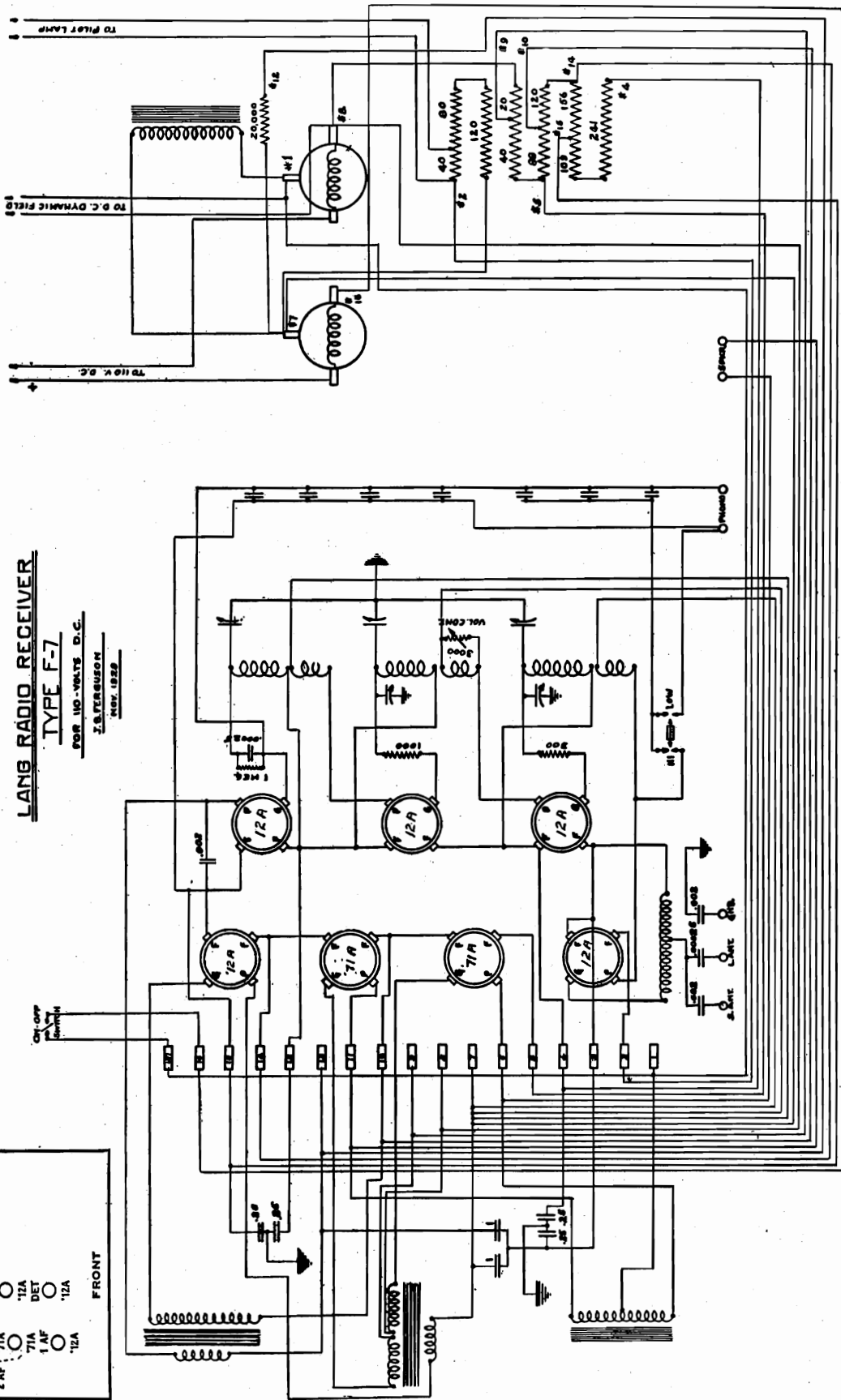

LANG RADIO RECEIVER
 TYPE F-7
 FOR 110-VOLTS D.C.
 J.S. FERUSON
 NOV. 1928

Model F-7 (1928)

1 RF	2 RF	3 RF	12A	71A	71A	71A	12A	FRONT
2 AF	71A	71A	12A	DET	12A	1 AF	12A	

MODEL SA-7
MODEL SA-8

LANG RADIO CO.

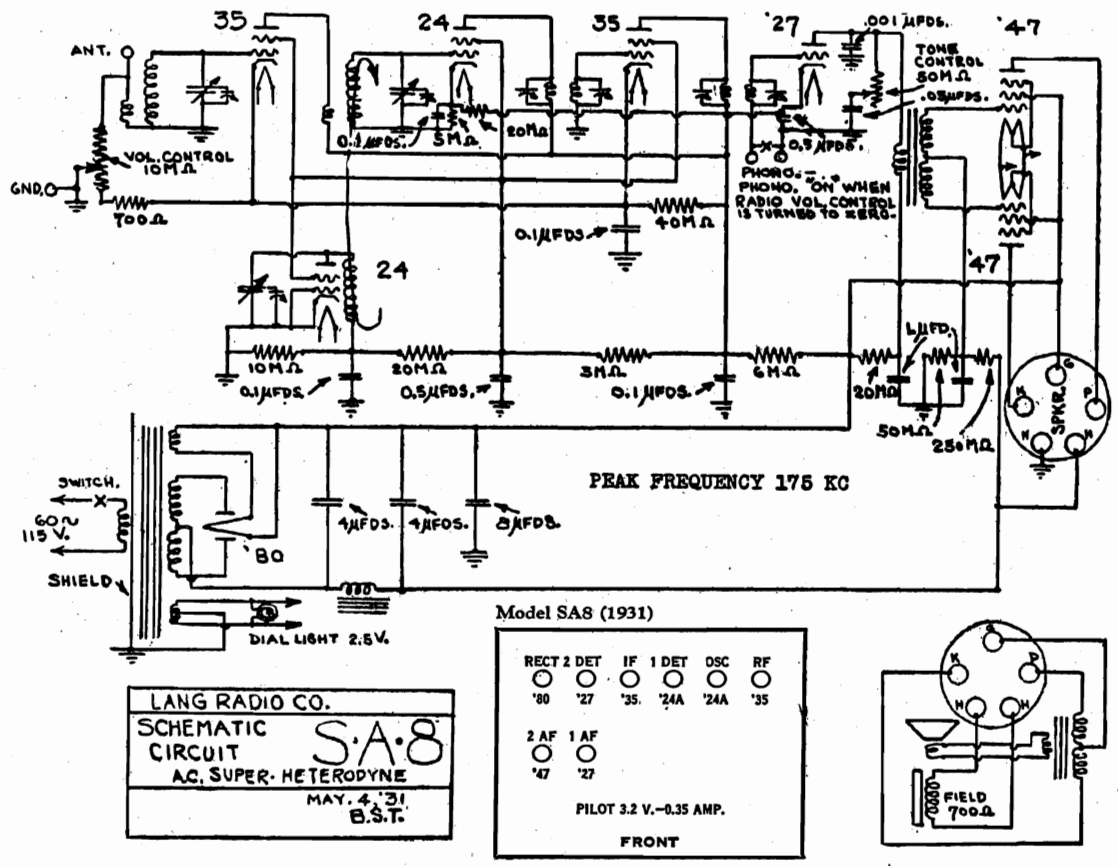
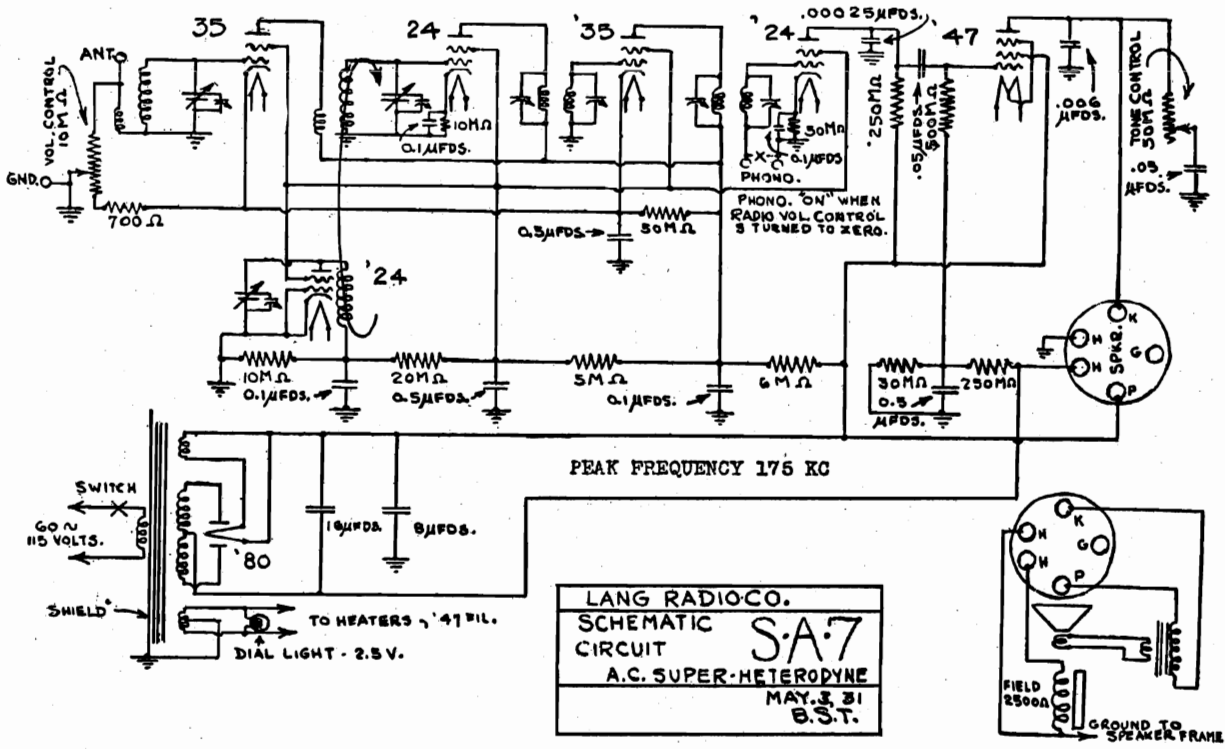

MONTGOMERY-WARD & CO.

MODEL 62-030
62-232
Troubadour

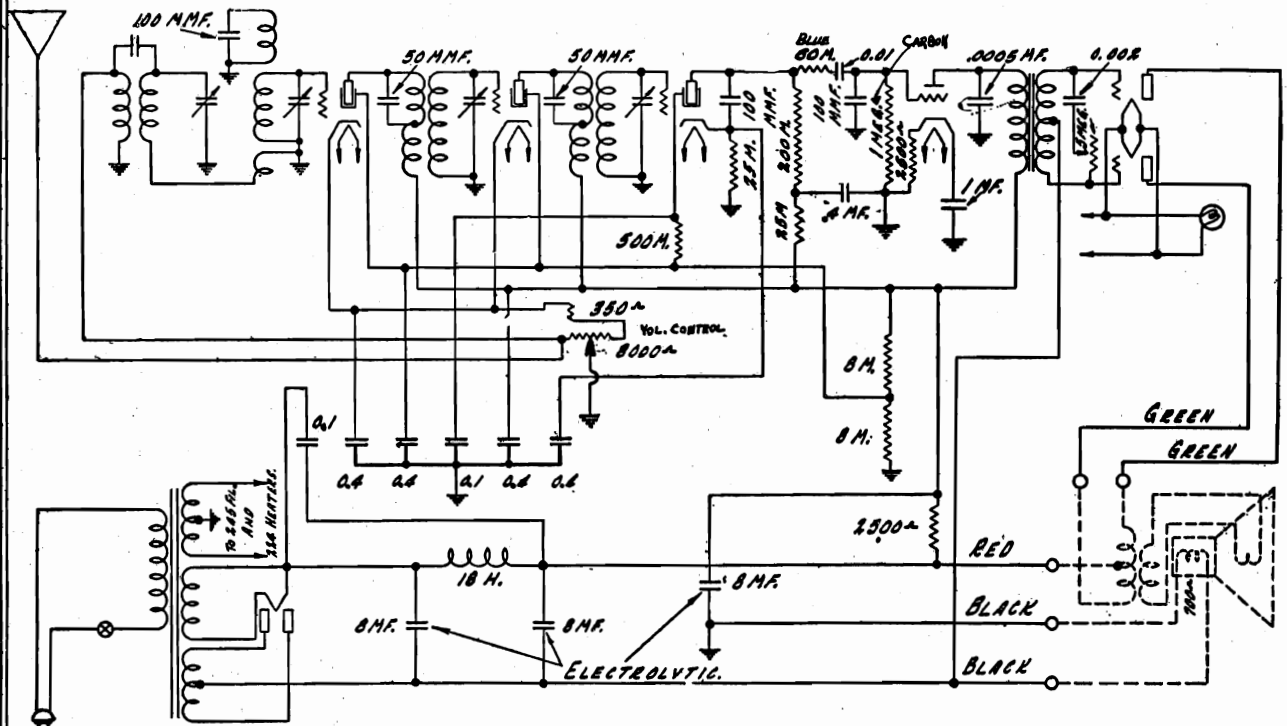

DOTTED LINES SHOWN ARE IN SPEAKER.

The model 32W chassis used in the Troubadour and Lafayette is similar in many respects to the Commander, Cavalier, Coronado and Cortez. The special differential features of this chassis are the band pass filter and the radio frequency transformers.

A band pass filter is used in the antenna input stage, and consists of two separate tuned circuits which are inductively coupled. The advantages of this filter are an increase in selectivity; elimination of cross talk and improved tone. Incorporated in the filter is a special coil and condenser, which is inductively coupled to the grid coil of the first tube, tending to give this stage a constant gain over the entire frequency band.

Another feature of this set is the tuned radio frequency coils which have two separate primary windings, so connected as to give equal gain throughout the broadcast band. A screen grid power detector is used, giving the advantages of sensitivity with very good overload characteristics. The over-all fidelity response characteristics are especially good, due to the resistance coupling used in the first stage of audio, and the 245 tubes in push pull in the last stage. Sensitivity in this chassis averages 4 Microvolts per meter.

R.F. Coils

The antenna input transformer is of the high impedance type, and is both inductively and capacitively coupled. The primary winding is on a small bobbin inside the coil form wound concentric with the secondary, allowing inductive coupling. The capacity coupling is obtained by an extra turn of wire connected to the primary and wound on the coil alongside one end of the secondary winding. This antenna coil is coupled to the grid coil of the first tube through three turns of wire wound on the low potential end of the grid coil. Inside of the grid coil is a small bobbin coil shunted by a 100 mmfd. condenser, and being in inductive relation to the grid coil. This small coil with condenser in shunt is tuned to the lower frequency. The 100 mmfd. condenser is a small condenser without any color marking to distinguish it from the 50 M.M.F. condensers with the yellow dot which are used in the other stages of the radio frequency. The primaries of the radio frequency coils proper, are made up of two parts; the inside primary is wound on a bobbin which is inside the coil form, and is shunted with a 50 M.M.F. condenser. The outside primary is wound on the coil form over the secondary winding and is separated by an insulated strip, the two primaries being connected in series. The energy transfer of the inside tuned primary decreases with increase in frequency—the energy trans-

fer of the outside primary increases with increase in frequency, resulting in a net gain that is practically uniform over the broadcast band. Any trouble in the R.F. coils of this receiver will be noted by the lack of sensitivity at either the high or low wave part of the dial.

Twenty-Five Cycle Chassis

A twenty-five cycle power transformer and an additional .45 M.F.D. condenser are used in this chassis. In converting a sixty cycle chassis to twenty-five cycle, first remove the .1 M.F.D. condenser across the filter choke and connect it across the .1 M.F.D. screen condenser. This provides additional filtering. Connect the .45 M.F.D. condenser across the filter choke.

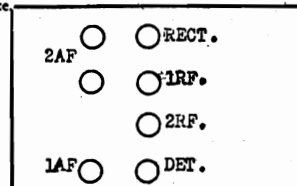

NO. 32 W CHASSIS—VOLTAGES AT SOCKETS—VOLUME CONTROL AT MAXIMUM—LINE VOLTAGE, 115—PLUG IN SOCKET OF RECEIVER—TUBE IN TEST SET

Type of Tube	Position of Tube	Function	"A" Volts	"B" Volts	Control Grid "C" Volts	Screen Volts	Screen Current MA	Cathode Volts	Plate MA	Grid Test MA
234	1	1st Radio	2.3	198	3	88	.9	3	3.5	6
224	2	2nd Radio	2.3	198	3	88	.9	3	3.5	6
224	3	Detector	2.3	150	6	40*	.1	6	25	.4
227	4	1st Audio	2.3	180	12.5			12.5	5	6.1
245	5	2nd Audio	2.4	255	55			26	31	
245	6	2nd Audio	2.4	255	55			26	31	
280	7	Rectifier	5					36		

*Calculated value—cannot be read on ordinary Voltmeter.

MODEL 62-040
Comodore
62-181
Sovereign

MONTGOMERY-WARD & CO.

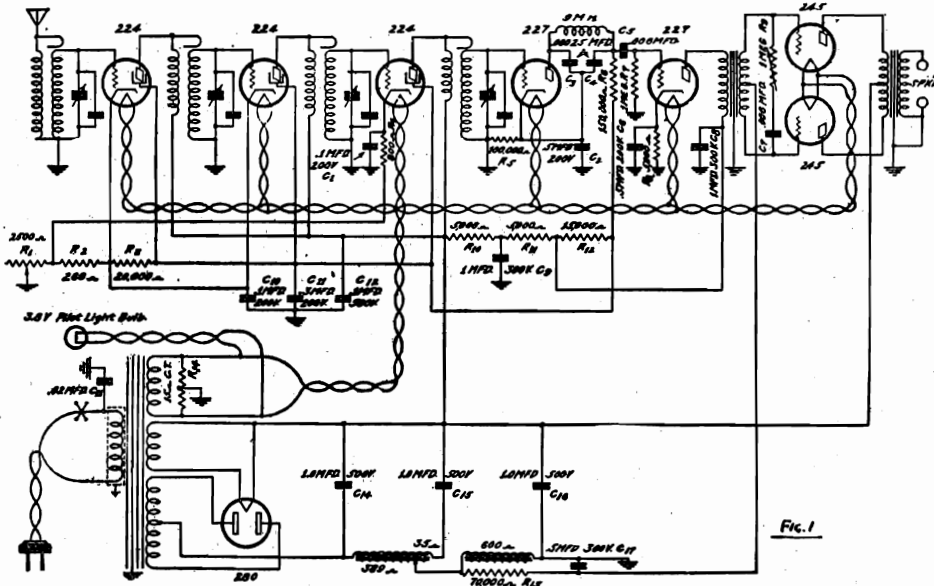

Fig. 1

IMPORTANT
All chassis below serial number 139149 use volume control P-90966 shown in Figure 1. Chassis above 139149 use volume control P90969 shown in Figure 3. When replacing volume controls use P90969 and volume control connections shown in Fig. 3.

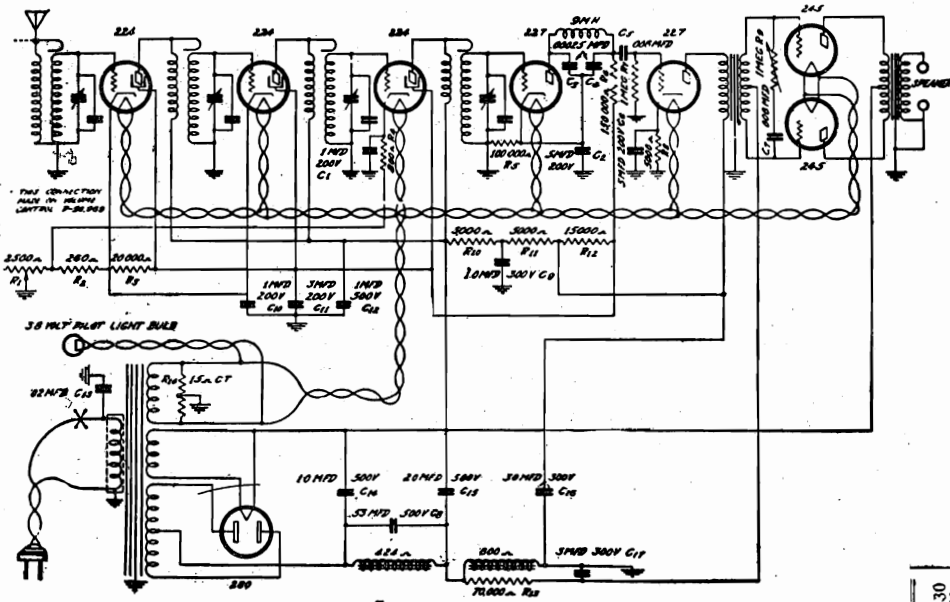

Fig. 3 25-Cycle Chassis

Tube Voltages

All D.C. voltages taken with a 1000 ohm per volt meter on the scale indicated in column headed "Meter Scale." Turn the volume control all the way on and connect the antenna and ground leads together. The grid, plate, and screen grid voltages are measured to cathode of the heater tubes and to filament of three-element tubes.
The dynamic load speaker has a field resistance of 600 ohms. The field is used as one of the filter chokes in the power pack.

Tube	Circuit	Meter Scale	90 V.	100 V.	110 V.	120 V.	130 V.
1st two 224 R.F. Amplifier Tubes	Grid	0-5	-2.5	-2.9	-3.3	-3.7	-4.1
	Screen Grid	0-100	62	70	76	84	90
	Plate	0-750	220	240	270	295	310
2nd 224 R.F. Amplifier Tube	Grid	0-5	-1.9	-2.3	-2.6	-3.0	-3.4
	Plate	0-10	2.4	2.7	3.0	3.3	3.6
Detector 227 Tube	Grid	0-10	21.0	24.0	26.0	29.0	32.0
	Plate	0-10	3	4	5	5.5	6
227 Audio Amplifier Tube	Grid	0-250	90	145	158	170	183
	Plate	0-100	30	34	39	43	47
245 Power Tubes	Grid	0-750	220	240	275	300	320
	Plate	0-750	300	330	360	400	415

R.F. Coils

The R.F. Coils on this receiver are both inductively and capacitively coupled in such a way that the R.F. gain is constant throughout the entire broadcast band. Each coil is marked with a streak of paint inside the secondary coil near the lugs, according to the group into which it falls. Four coils of the same color are used in each chassis. When ordering a coil for replacement, therefore, be sure to mention the color of the paint on that coil so that it will be replaced with one of identically the same characteristics. If there is any doubt, return the coil. It is seldom that one of these radio frequency coils needs replacement, but should it be necessary to do so, first unsolder the wires on the coil lugs, then loosen the nuts holding the metal coil can. After the coil can is removed, loosen the two nuts holding the coil form and remove the coil.

Models 62-040, 62-181, 62-3335, 181, 187 (1930)

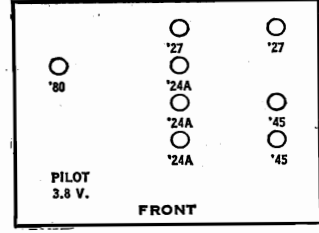

MONTGOMERY-WARD & CO.

MODEL 62-11, 62-12, 62-14,
62-27, 62-19
Schematic (1st. Type)
Voltage

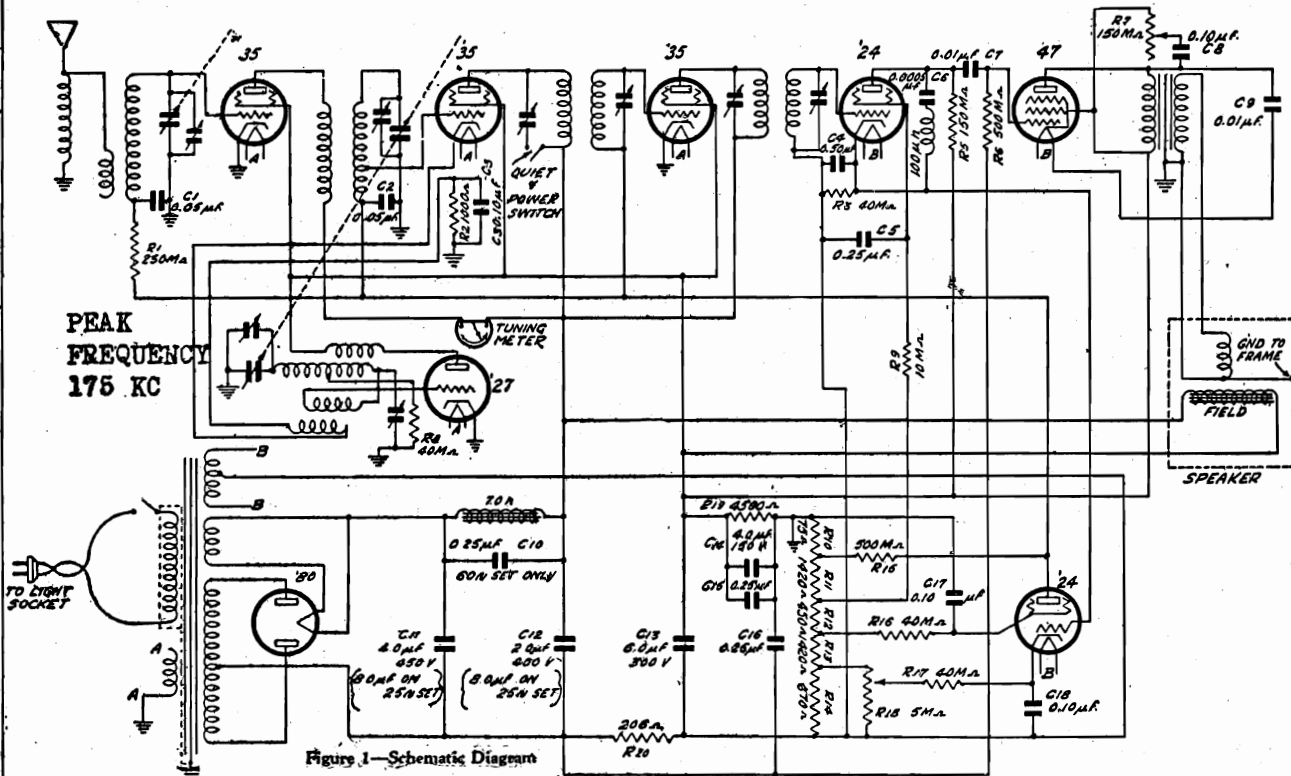

Figure 1—Schematic Diagram

TUBE	CIRCUIT	LINE VOLTAGE				
		90 V.	100 V.	110 V.	120 V.	130 V.
R.F.	Screen grid	70	78	85	92	100
'35	Plate	143	159	175	191	207
1st Det.	Screen grid	70	78	85	92	100
'35	Plate	143	159	175	191	207
I. F.	Screen grid	70	78	85	92	100
'35	Plate	143	149	175	191	207
Oscillator ..	Plate	70	78	85	92	100
'27						
2nd-Det.	Screen grid	66	73	80	87	94
'24	Plate	127	134	141	148	155
A. V. C.	—	14	15.5	17	18.5	20
'24	—Grid grid	24	26	28	30	32
Audio	Screen					
'47	Accel. Grid	199	221	244	267	289
	Plate	171	190	210	230	250
Rectifier ...	Current (both plates) ..	67 MA	75 MA	82 MA	89 MA	96 MA
'80	Plate to Plate Voltage ..	512	569	625	682	739

The voltage readings on this chassis cannot be taken in the conventional way, namely between the tube elements and ground. You will note from diagram Figure No. 1, that the ground connection is taken off the shunt resistor near to the positive end, and the chassis is therefore, approximately 150 Volts positive, with respect to the tube elements. The correct voltage readings may be obtained by taking readings to the cathode of the heater type tubes, and filament of the 247.

TURN THE VOLUME CONTROL ALL THE WAY ON, CONNECT THE ANTENNA AND GROUND LEADS TOGETHER AND TURN THE GANG CONDENSER PLATES ALL THE WAY OUT. CHECK THE LINE VOLTAGE.

NOTE "GRENADIER" No 62-12

Two entirely different chassis were supplied to the Retail Stores under the name "Grenadier." Each chassis, however, has a different Catalogue number and should be distinguished from this number. The Grenadier No. 62-12 uses the U. S. Radio 8 tube chassis and is exactly the same as our Nos. 1238 and 1838. Therefore, when servicing or ordering repair parts for the Grenadier No. 62-12, use the No. 1238 and 1838 service manual. Grenadier No. 62-14 (Catalogue No. 62-11) is the Wells-Gardner 8 tube chassis which will be described in this service manual.

MONTGOMERY-WARD & CO.

MODEL 62-11, 62-12, 62-14

62-27

Socket-Data

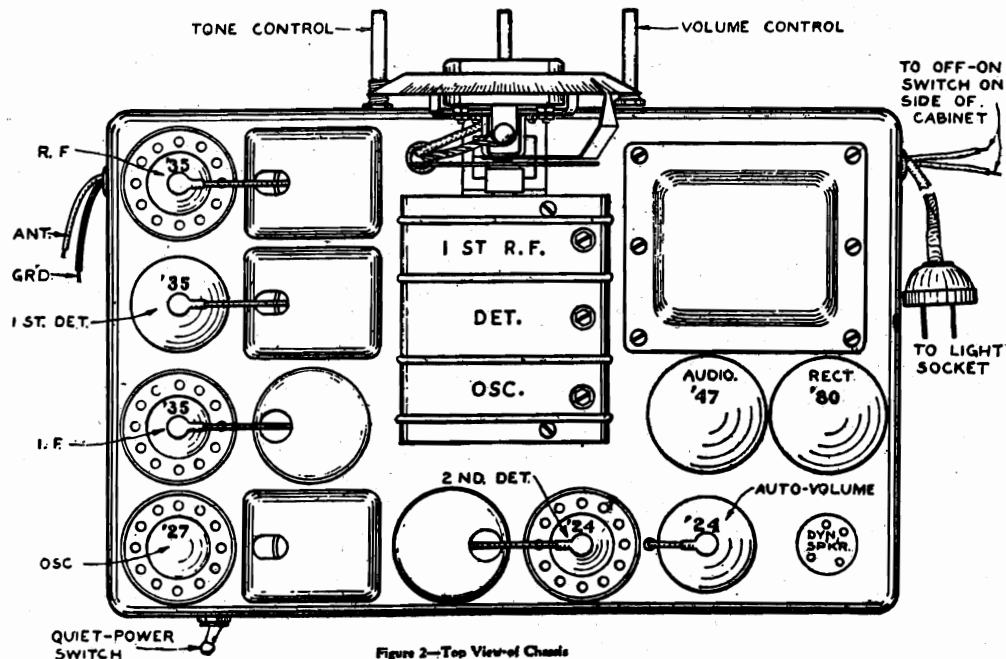

Figure 2—Top View of Chassis

Oscillator

A 227 tube used in this socket that does not oscillate will completely stop any signals from reaching the intermediate frequency amplifier and the chassis will not operate. There is also a slight variation in the characteristics of tubes, and for this reason it is advisable to try a number of tubes in the oscillator position and to use the one which gives the most satisfactory performance.

The oscillator has an adjustable tracking condenser which is adjusted at 600 kilocycles and remains fixed thereafter.

Automatic Volume Control Tube

The automatic volume control tube is equally as important as the oscillator tube. In this chassis a 224 is used. If the A.V.C. tube's characteristics are not exact, it will cause the chassis to lack sensitivity or spoil the tone quality. The tuning meter will not function properly with a poor A.V.C. tube. If the grid circuit of this tube is open the chassis will lose its sensitivity and in some cases will not pass signals. In each installation, therefore, it is advisable to try a number of 224's in the automatic volume control position and use the tube which gives the most satisfactory performance as to control of volume, operation of tuning meter, and tone quality.

Replacing Rubber Drive

You will note that the Vernier tuning drive on this chassis uses a rubber pinion. Under normal operating conditions this rubber will last for a number of years. Should it become worn it can be readily replaced by loosening the set screw of the brass bushing located next to the rubber pinion and pulling out the station selector shaft. Place a new bushing in position, slip the station selector shaft in place and tighten the set screw.

25 Cycle Chassis No. 62-14X

The 25 cycle receivers use power transformer No. P50540 instead of P50539. Two 8.0 mfd. electrolytic condensers No. P80880 are used instead of No. P80873 and No. P80874. The .25 mfd choke condenser C10 is not used in the 25 cycle chassis.

Resonance Meter

This meter is a small milliammeter in the plate return of the R. F. tube. When the receiver is turned on, and no signal is tuned in, the meter will indicate the total plate current drawn by the R. F. tube. When a signal is tuned in, the meter will indicate less current, and when tuned to resonance, the greatest swing (or least deflection), of the meter hand will be obtained.

The deflection of the meter hand will vary according to the setting of the manual volume control on this chassis.

Method of Aligning

These chassis will only lose their alignment when they have been subject to extremely rough handling or have been used under abnormal conditions, as for instance, a very hot or very humid location. Under any one of these conditions, the alignment may shift slightly and the chassis should be realigned according to the following procedure.

Tune in a local station of approximately 1400 Kilocycles, being very careful to tune this station in at the exact resonance point. This may be easily done by carefully adjusting for maximum deflection of the tuning meter. Then reduce the volume to the desired level. Turn to Figure 2 and note the position of the first radio frequency trimmer adjustment. Slowly turn the trimmer to the right or left until the signal is at maximum intensity. Proceed to adjust the detector trimmer in the same manner. In most instances these two adjustments will align the chassis perfectly. If the receiver still lacks sensitivity after the first RF and detector trimmers have been adjusted, then the oscillator trimmer may be checked by turning the adjusting screw not more than a quarter of a turn to the right or left of its present adjustment. When aligning any of these receivers be sure that the condenser shield is firmly in place and that you are using good tubes in the chassis. This is particularly true in case of the oscillator and automatic volume control tube.

The R. F., 1st detector, oscillator and 1st I. F. tubes have one side of their heater circuit grounded.

The voice coil and speaker frame are grounded to prevent any "feedback" of a 175 K. C. frequency which might enter the speaker.

MONTGOMERY-WARD & CO.

MODEL 62-070
Princess
62-060
Challenger Jr.
(1800)

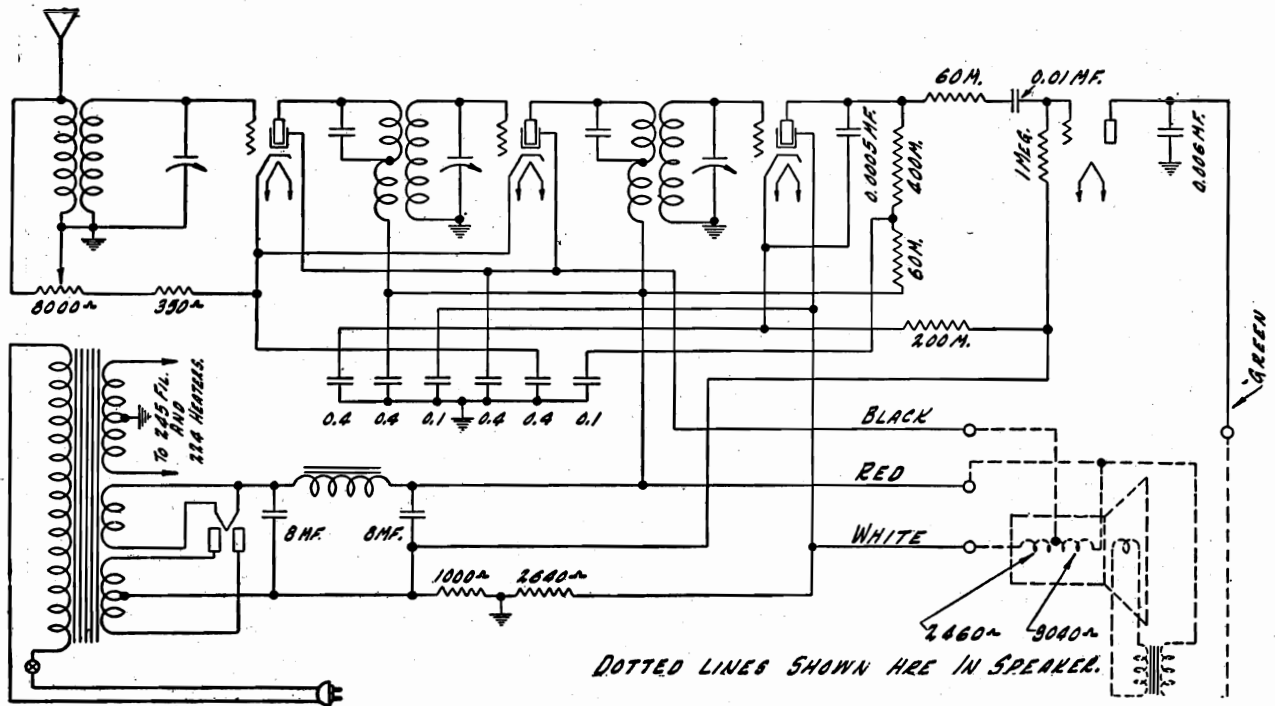

DOTTED LINES SHOWN HERE IN SPEAKER.

NO. 26 W CHASSIS—VOLTAGES AT SOCKETS—
VOLUME CONTROL AT MAXIMUM—LINE VOLT-
AGE, 115—PLUG IN SOCKET OF RECEIVER—
TUBE IN TEST SET

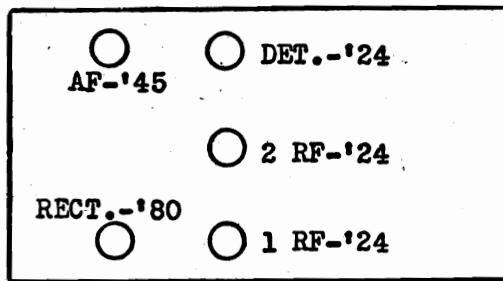

General Description

The Model 26W chassis used in both the Princess and Challenger, Jr., is similar in many respects to the 32W chassis used in the Troubadour. The operating voltages, however, will be found to be different, and also this chassis does not use the band pass filter input circuit, as used in the 32W. Only one 245 tube is used in this chassis, and only one stage of resistance coupled audio.

The speaker is of a new type using a center tap field. The entire field winding being used as a shunt resistor. The center tap supplies the screen grid voltage to the radio frequency tubes. Only two electrolytic filter condensers are used, and a number of the small bypass condensers are eliminated, as shown in the schematic diagram, Figure I.

The general service procedure as described for the Model 32 W chassis can be used in servicing the 26W chassis.

Type of Tube	Position Tube	Function	"A" Volts	"B" Volts	Control Grid "C" Volts	Screen Volts	Screen Current MA	Cathode Volts	Plate MA	Grid Test MA
224	1	1st Radio	2.2	245	2.5	80	.6	2.5	2.9	5.1
224	2	2nd Radio	2.2	245	2.5	80	.6	2.5	2.9	5.1
224	3	Detector	2.2	130	3.	40	.1	3.	.25	.4
245	4	Audio	2.35	245	50.			28.		31.
280	5	Rectifier	4.6					25.		

AIRLINE 5 TUBE S.G.

• "Princess" No 62-070
and
"Challenger Jr." No 62-060
(Cat. No 1800)

60 v CHASSIS No 26-W
25 v " No 26-WX

NOTE: For 25 Cycle Sets use No. 2281 Power Transformer instead of No. 2251.

MODEL 921, 923, 924, 839
(Radiola 21, 22)
Conversion Data

MONTGOMERY-WARD & CO.

Method of Converting a 6 Volt Receiver for Using the 2 Volt Tubes

ALL of the original Radiola Models 21 (Table Model) and 22 (Console Model) were designed for 6 Volt storage battery operation. It is possible, however, to change the wiring of these sets slightly so that the new 2 Volt dry cell tubes may be used in conjunction with either the Aircell battery or our 2 Volt long life A battery.

Description of the original receiver for storage battery operation is given first. Following this, the method of changing over the set for 2 Volt tubes will be shown. The original color code is shown on the schematic diagram, Figure No. 1. For storage battery operation the cable should be connected to the batteries according to this code.

The following parts are necessary:

One No. 6000 long life A battery designed to last one year at three hours a day. One kit of tubes consisting of 2—No. 232 screen grids; 2—No. 230's; 1—No. 231. One new instruction book. One No. 5512-75 Milliampere pilot light. One pair of green and red resistors. One socket chart label to stick over old RCA labels. The last four items can be ordered on stock order by specifying "one conversion kit for Radiola Set." The A battery and tubes should be ordered on stock order in the usual way. When you receive all of the necessary parts to make the conversion, you will use them in the following manner:

Operation No. 1

First examine Figure No. 2. There are three resistors at the back of the chassis mounted directly underneath the sub-panel. The wires attached to these three resistors must not be removed but the three resistors should be shorted out by soldering short pieces of wire across as shown on the dotted lines in Figure No. 2. On the console models it is not necessary to remove the chassis to do this. Remove the chassis when changing the table model.

Operation No. 2

Insert new low drain pilot light and adjust the position by sliding the pilot light clamp up and down until the figures on the dial can be seen prominently.

NOTE: The insertion of this new pilot light is extremely important—the life of the A battery depends upon it.

Operation No. 3

Remove the Radiola instruction book, red service card and pilot light. Discard them.

Operation No. 4

Remove the battery tag from the cable and destroy it.

Operation No. 5

Connect one end of the green (2.2 Ohms) resistor to the end of the yellow positive A battery lead. This is important.

Operation No. 6

Insert new instruction books and paste new tube chart label over RCA tube position chart, and advertising sticker. This label is designed to cover the tube replacement label and the socket chart. Don't cover up the license notice.

The tube chart indicates the position of the new tubes, 232's—R.F. stages—230's—1st Audio and Detector—231—last audio.

The red resistor is given to the customer in an envelope. It contains a small red label tied at one end and instructing the customer how to use it, which is as follows:

Over a period of time the A battery voltage will drop. Its initial voltage is slightly over 3 Volts. The green re-

sistor drops this 3 Volts down to 2 Volts for the tubes. After the set has been used for a few months the battery voltage will drop to about 2½ Volts, so it is necessary to use a smaller resistor on the battery to give the tubes 2 Volts. When the set begins to lose volume and the tubes go dim, the green resistor should be replaced with the red resistor. After the receiver has been in use a few months more, the battery voltage will drop to about 2 Volts, then the resistor should be removed entirely and the battery used alone until dead.

Note: The new color code and method of connecting the battery cable is shown in Figure No. 3. Use this color code for connecting the batteries after the conversion is made.

Caution: Be sure all battery connections are correct.

Alignment:

In order to align the condensers, it is necessary both in the console and table model, to first remove the chassis from the cabinet. Connect up all batteries and tune in a station at about 1400 Kilocycles. The trimmer condensers will be found mounted on the frame of the variable condenser nearest the front panel. These should be adjusted in turn for maximum volume on a station that does not fade.

Long Distance Switch:

In many localities the local distance switch will not operate satisfactorily on the local side.

In the country it is seldom necessary to use the local switch on the local side, for it is only put on as a safeguard to enable proper control of volume when under the shadow of powerful broadcast stations.

IMPORTANT NOTICE

If the pilot light should burn out and you are unable to obtain another one immediately, remove the celluloid strip from the escutcheon plate by sliding it out of its slot from the rear. This will enable the user to see the figures on the dial until such time as you are able to put the correct pilot light in place. Never use any pilot light but the No. 5512 we recommend.

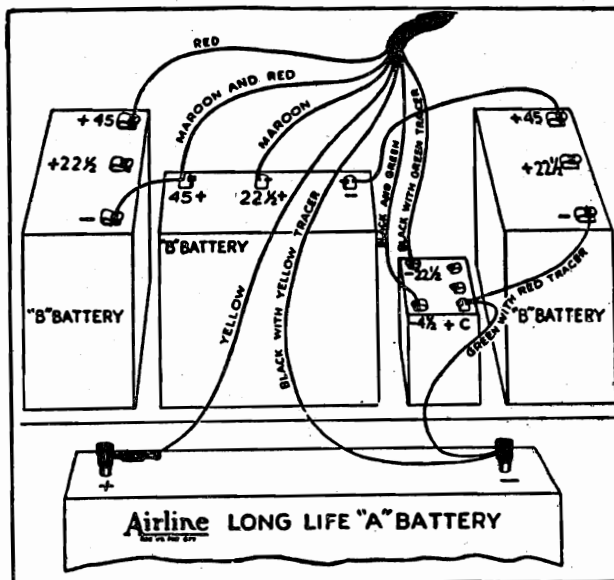

MONTGOMERY-WARD & CO.

MODEL 921, 923, 924, 839
(Radiola 21, 22)
Schematic-Data.

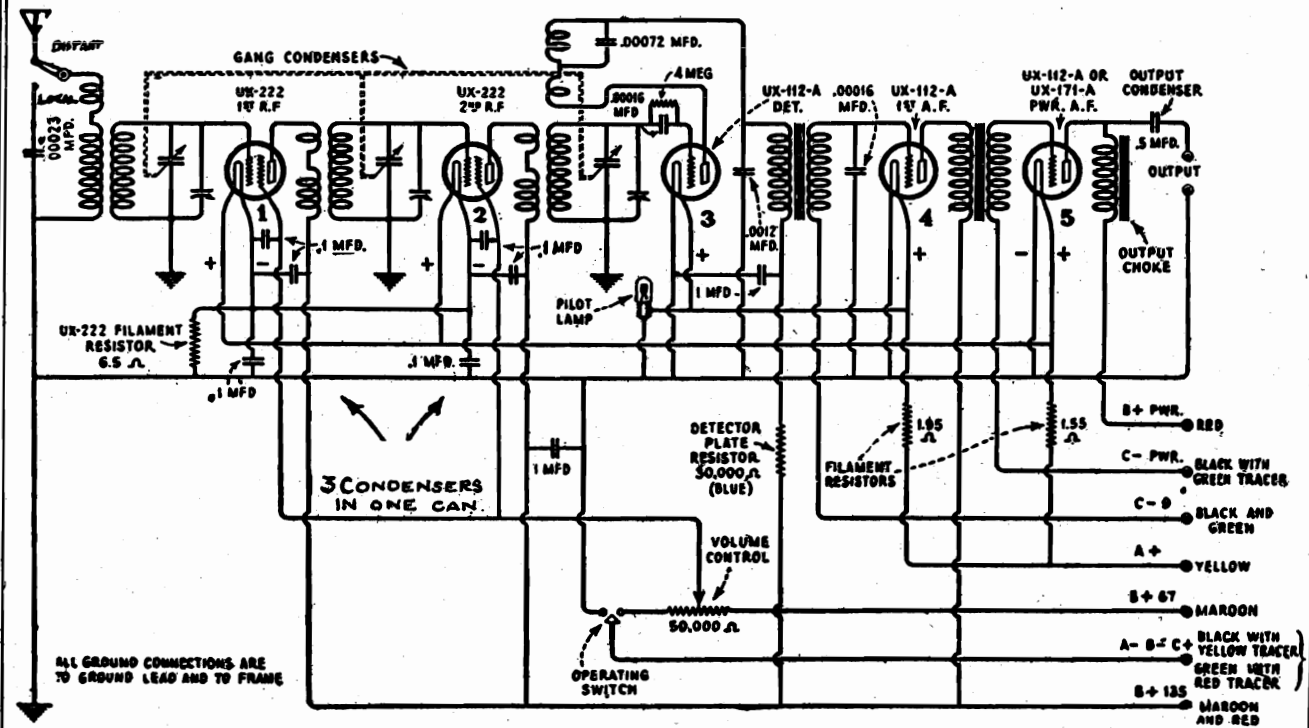

General Description

Radiolas 21 and 22 are the tuned RF type, using two stages of radio frequency and one tuned antenna stage. The antenna coil has a high impedance primary and for this reason will give most satisfactory performance on an outside aerial of from forty to seventy-five feet long, including Lead-in. A forty foot aerial should be used in congested localities where there is serious interference. In the event it is impossible to install an aerial and lead-in of from forty to seventy-five feet, a longer aerial may be used and a .0005 or .0001 MFD fixed condenser connected in series with the antenna connection to the set.

Volume Control

The volume control consists of a 50,000 Ohm Potentiometer connected in the B+67 Volt lead and controls the screen voltage to the two RF tubes. The on and off switch is of a special type which automatically breaks the A & B connections when snapped in the off position.

Six Volt Storage Battery Operation

Figure No. 1 gives the completed circuit for operation on 6 Volt A supply. Two type 222 tubes are used as radio frequency amplifiers. A 112A detector, a 112A tube in the first audio stage and a 112A or 171A tube in the second audio stage. The two 222's used in the RF stages receive their filament supply of 3.2 Volts through the 6½ Ohm resistor connected in the A. negative lead. The detector and first audio are operated at 5 Volts through the 1.95 Ohm filament resistor in the positive A lead. The filament of the power stage is supplied through the 1.55 Ohm filament resistor. A 171A power tube may be used in the power stage with the proper B supply of 180 Volts and 40½ Volts C. A 112A tube using 135 Volts of B and 9 Volts of C is recommended however, for most economical operation.

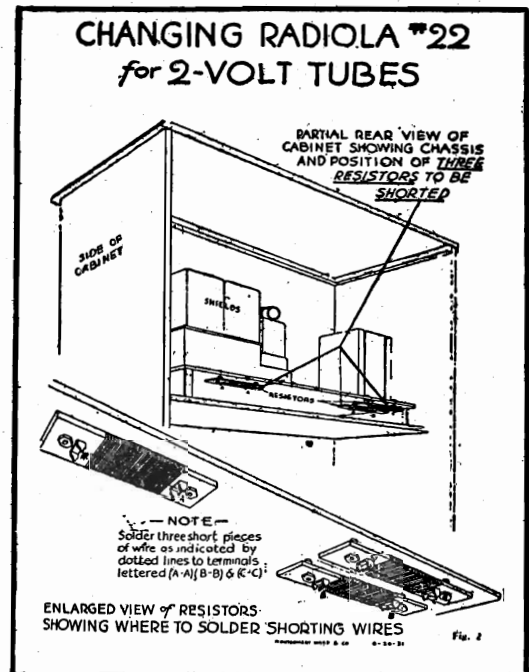
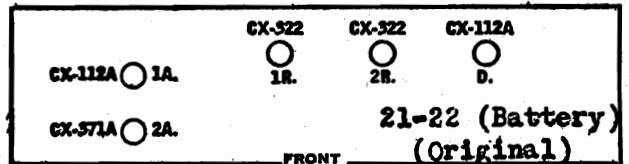

MODEL 1111 (62-1611)
 Fantasy
 811 (62-1711)
 Solo
 Voltage-Data

MONTGOMERY-WARD & CO.

Models 811, 811X, 1111, 1111X (1931)

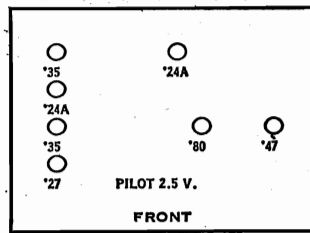

R.F. and Oscillator Transformers

The antenna and R.F. coupling transformers are properly shielded and the oscillator unit is assembled in a shield together with the 600 K.C. tracking condenser, the .00075 condenser (C16) and the resistor (R14) to ground. This method of assembly has eliminated radiation which is a common fault in superheterodyne receivers.

These three units are matched within one microhenry. Each coil has a paint mark inside the coil form near the terminal lugs and the color of this mark indicates the inductance of the coils. The antenna, R.F., and oscillator units in each receiver have the same color and it is necessary that the color be mentioned when ordering a transformer for replacement.

RESISTORS

Diagram Key	Part No.	Resistance in ohms	Type
R1	P-90976		Vol. Cont.
R1	P-90978		Vol. Cont. With Switch
R3	P-90905-B	15,000	Carbon
R4	P-90916-B	40,000	Carbon
R5	P-90927-A	25,000	Carbon
R6	P-90926-A	30,000	Carbon
R7	P-90956	30,000	Carbon
R8	P-90977	1 Meg.	Tone Cont.
R9	P-90938-A	500,000	Carbon
R10	P-90941-A	50,000	Carbon
R11	P-90959-A	20,000	Carbon
R12	P-90930-C	10,000	Carbon
R13	P-90906-B	2,000	Carbon
R14	P-90956-A	30,000	Carbon
R15	P-90975-A	270	Candohm
R16	P-90963-A	150,000	Carbon
R17	P-90979	7,000	Carbon

STANDARD COLOR CODE

Tube	Circuit	Meter Scale	110 V.
R.F. (Ant) '35	Grid Screen Grid Plate	0—10 0—100 0—250	1.9 63. 225.
1st Det. '24	Grid Screen Grid Plate	0—25 0—100 0—250	14.5 65. 220.
Int. '35	Grid Screen Grid Plate	0—10 0—100 0—250	1.9 63. 225.
2nd Det. '24	Grid Screen Grid Plate	0—25 0—100 0—250	14.5 65. 135.
Osc. '27	Grid Plate	0—100	80.
Aud. '47 (See Caution Above)	Grid Accelerating Grid Plate	0—10 0—250 0—250	2.7 225. 205.
'80 Rect.	Filament, to Ground	0—1000	233.

Tuning

The primary and secondary of both intermediate transformers are tuned with adjustable condensers which remain fixed after the transformers have been tuned to exactly 175 kilocycles.

The oscillator has an adjustable tracking condenser which is adjusted at 600 kilocycles and remains fixed thereafter.

Condensers and Resistors

Three blocks contain the majority of condensers. The choke in the plate circuit of the second detector tube is, also contained in one of these blocks. The common leads of condenser blocks No. 1 and No. 2 are grounded. C1, C4, and C6 in block No. 3 have a common lead which is grounded, and the choke, and C3 in this block have a common lead connected to the plate of the 2nd detector.

ANALYZER CHART

All voltages taken with a 1,000 ohm per volt voltmeter on the scale indicated in the column headed "Meter Scale." Turn the volume all the way on and connect the antenna and ground leads together. The grid, plate, and screen grid voltages are measured to cathode of the '24 and '35 tubes and to filament of the '47 tube.

The grid voltage on the '27 oscillator cannot be taken except with a very sensitive, low scale voltmeter. The voltage is approximately .05 volts when the A.C. line voltage is 110 volts.

MONTGOMERY-WARD & CO.

MODEL 1111 (62-1611
Fantasy
811 (62-1711)
Solo
Schematic

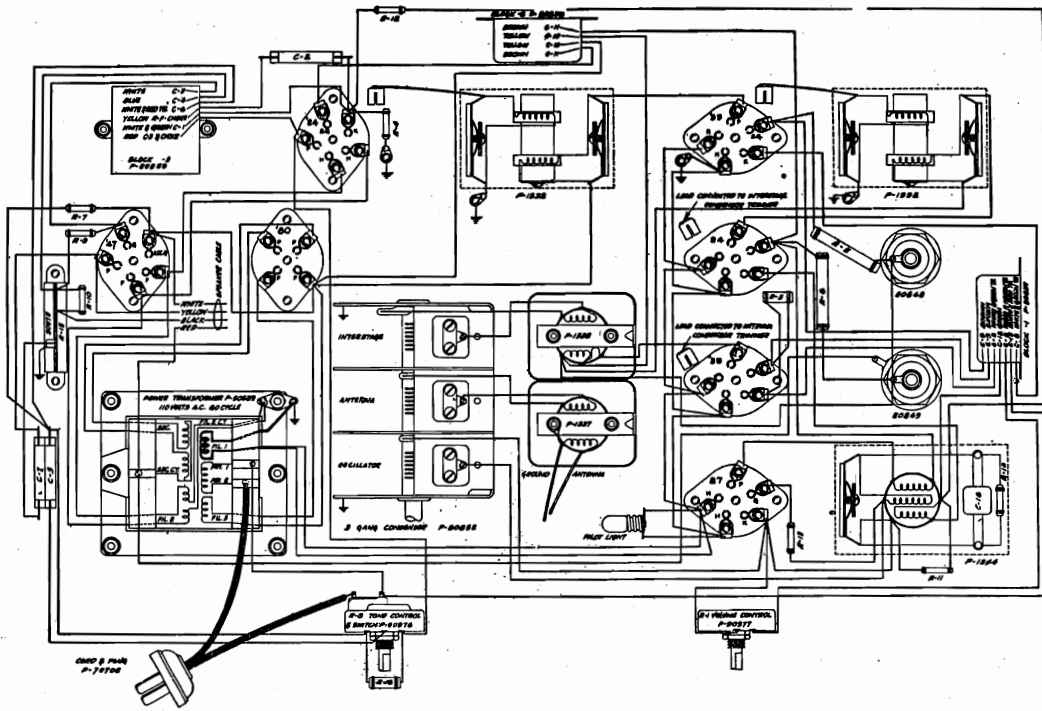
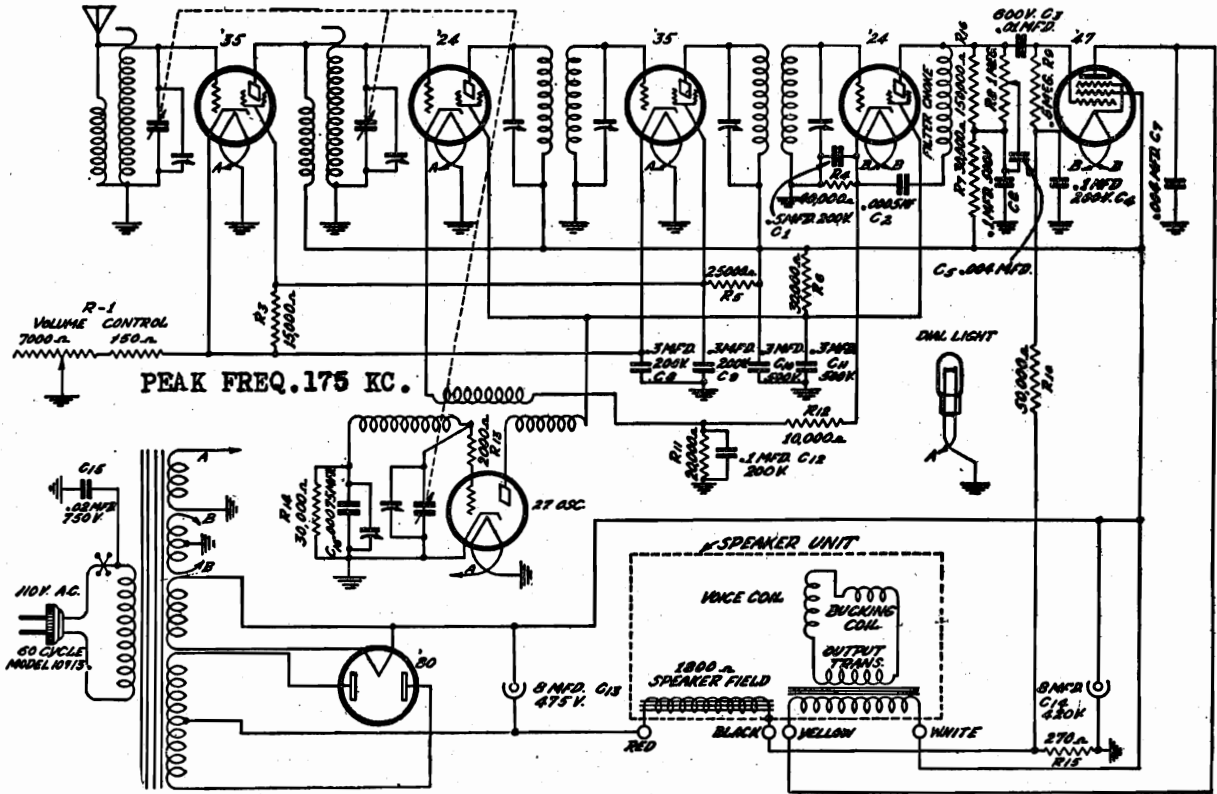

MONTGOMERY-WARD & CO.

MODEL 1355 (62-1955)

Minstrel
Schematic
Voltage

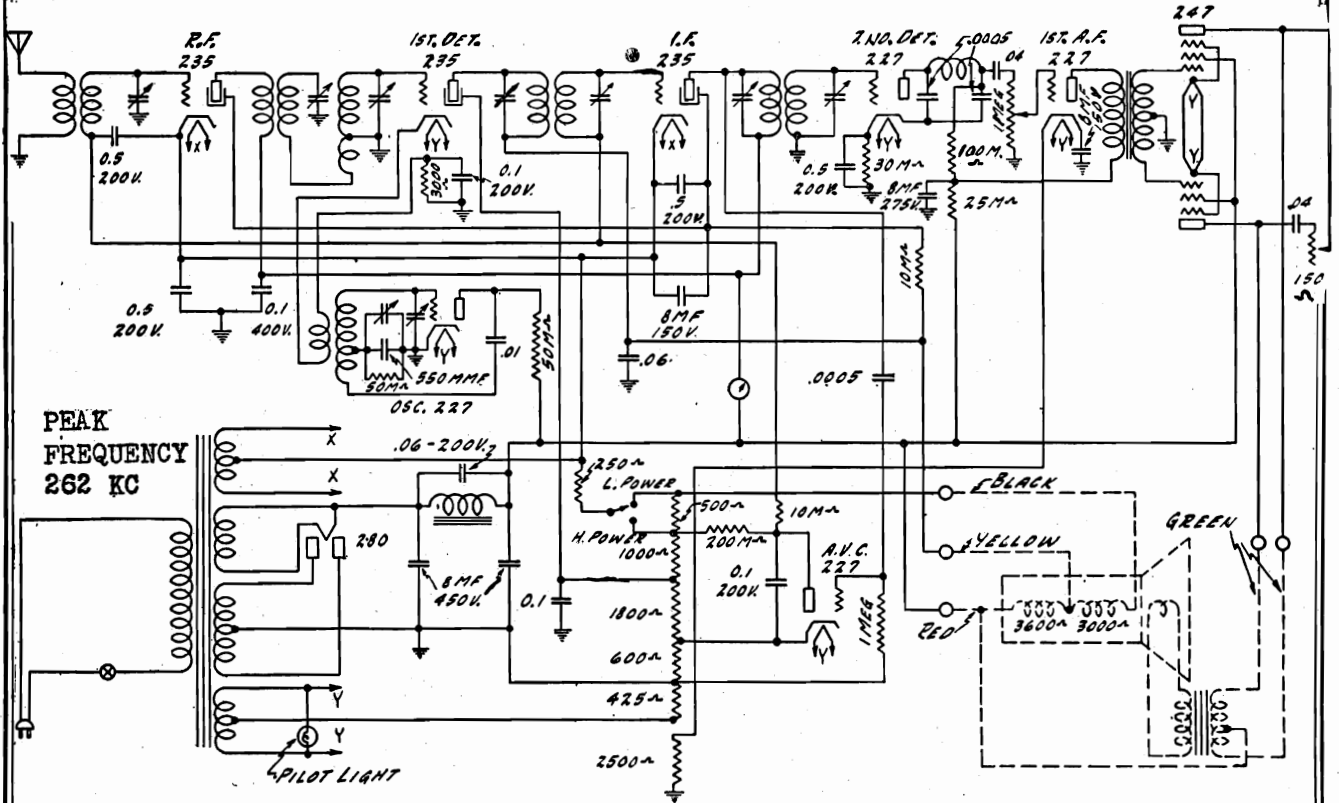

1955 AND 1355 CHASSIS—VOLTAGES AT SOCKETS
—LINE VOLTAGE 115 VOLUME CONTROL AT
MAXIMUM—POWER LEVEL SWITCH
HIGH POWER

Type of Tube	Position of Tube	Function	"A" Volts	"B" Volts	Control Grid "C" Volts	Screen Volts	Screen Current MA	Cathode Volts	Plate MA	Grid Test MA
235	1	R.F.	2.3	175	2.3 ⁽¹⁾	65	.7	0.	4.	6.
235	2	1st Det.	2.3	185	7.0	69	.4	14.	2.0	2.6
235	3	I.F.	2.3	175	2.3 ⁽¹⁾	65	.7	0.	4.0	6.0
227	4	2nd Det.	2.3	115	12.			7.5	4.	.5
227	5	1st Audic.	2.3	145	11. ⁽¹⁾			10.	4.6	5.4
227	6	Osc.	2.3	83	15—35 ⁽³⁾			21.	4.2	4.4
227	7	A.V.C.	2.3	89 ⁽⁴⁾	20. ⁽⁵⁾			1.5	0.	0.
247	8	Power	2.35	255	18.5	265	4.5			
247	9	Power	2.35	255	18.5	265	4.5			
280	10	Rect.	4.9						21.	28.

- (1) Measured across 250 ohm series resistor.
- (2) Measured across 2500 ohm series resistor.
- (3) Bias voltage varies from 15 to 35 between 1500 and 550 K.C. settings of tuning condenser.
- (4) Measured across 1000 and 1800 ohm section of shunt resistor.
- (5) Measured across 600 ohm section of shunt resistor.

Voltages

Check the voltages at the sockets to see if the power system is delivering the correct voltages. The antenna and ground should be disconnected. The tube shield should be on. The tester plug can be inserted in the sockets and the shield placed over it. When the plug is inserted in the 235 tube sockets care must be taken that the grid connection is not shorted to the tube shield. The chart shows the voltages and currents with all tubes in, speaker connected and set in operating condition.

In reading the I. F. voltages at the socket with a set analyzer some difficulty may be encountered if the control grid lead is in the same cable as the rest of the leads to the socket plug. If this is the case the grid plate capacity caused by the grid and plate leads being in the same cable results in a feed back which causes an I. F. oscillation. This manifests itself as a blocking or motorboating.

25 Cycle Chassis No. 1355X

For 25 cycle sets remove the .06 Mfd. condenser across the filter choke and use No. U-3169 power transformer instead of No. U-2912.

MODEL 1355 (62-1955)

Minstrel
Socket-Data

MONTGOMERY-WARD & CO.

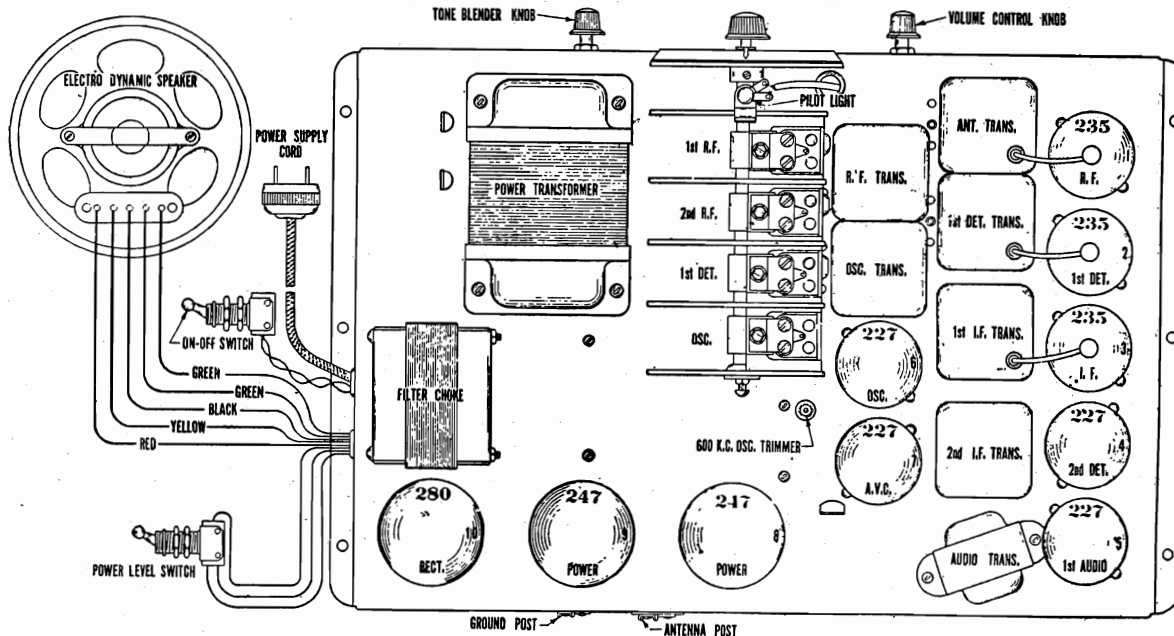

Automatic Volume Control

The automatic volume control as used in this receiver varies the signal strength by changing the bias voltage of the R. F. and I. F. 235 tubes. A 227 tube is used as the A. V. C. tube. Plate, cathode and grid circuits of this tube are connected to the voltage divider resistor as shown in Fig. 1 to secure the required plate and grid voltage. In the plate circuit of this tube is a 200,000 ohm resistor. The grid circuits of the R. F. and I. F. tubes are connected to the plate of the A. V. C. tube through a 10,000 ohm resistor. The cathodes of these two tubes are connected through the 250 ohm biasing resistor to the other end of this 200,000 ohm resistor in the plate circuit (power level switch on "H" power). The grid of the A. V. C. tube is connected to the plate of the I. F. 235 tube through a .0005 condenser. The A. V. C. tube has an initial bias of 20 volts and under conditions of no signal, no plate current flows in this tube. However, when an A. C. voltage of 15 or greater is applied to the grid circuit of the A. V. C. through the .0005 coupling condenser, plate current flows and a drop is established across the 200,000 ohm resistor. This lowers the voltage of the R. F. and I. F. grids, increasing the bias and decreasing the sensitivity in proportion to the strength of the signal being received. The higher the A. C. voltage applied to the A. V. C. grid the greater the drop across the 200,000 ohm resistor and the higher the bias voltage. For weak signals, therefore, the A. V. C. does not affect the bias and maximum sensitivity is obtained, while for strong signals the bias is increased and a corresponding reduction in sensitivity effected.

The I. F. transformers are small universal wound coils mounted on tubing. The I. F. tubing condensers are small mica condensers. The coil tubing and condensers are mounted on porcelain bases and are enclosed in metal cans located on top of the chassis. The adjusting screws of the four I. F. tuning condensers are reached from the bottom of the chassis.

Servicing

The usual checking of wiring and soldered connections and checking of resistors and condensers for opens, shorts, grounds and wrong value also apply, of course, to the Super-heterodyne. In working on the receiver care should be taken that the I. F. plate and grid leads are not bent too close to the chassis as the capacity to the ground will be excessively high. Note that the R. F. and I. F. control grids are not at ground potential and a slight shock can be obtained between the grid caps of these tubes and the chassis. Do not get the antenna lead near the 2nd detector as a harmonic of the signal in the 2nd detector plate circuit may feed into the antenna system and beat with the R. F. signal causing an audible whistle.

A good check to determine if the oscillator is working is to read the voltage across the 50,000 ohm resistor. This will vary between the limits as shown in the voltage chart for the oscillator bias, depending on the frequency to which the receiver is tuned.

In order to provide satisfactory tracking with the R. F. and first detector tuned circuits the oscillator is provided with a 600 K. C. and a 1400 K. C. trimmer condenser. The 1400 K. C. trimmer condenser is located on top of the tuning condenser and is connected across the oscillator tuning condenser. The 600 K. C. trimmer condenser is across the 550 Mmf. fixed condenser and the adjusting screw is in back of the tuning condenser on top of the chassis.

MODEL 1500
(27-W, 15000)
Collegian

MONTGOMERY-WARD & CO.

Models 27W, 27WX, 1500, 15000, (1930)

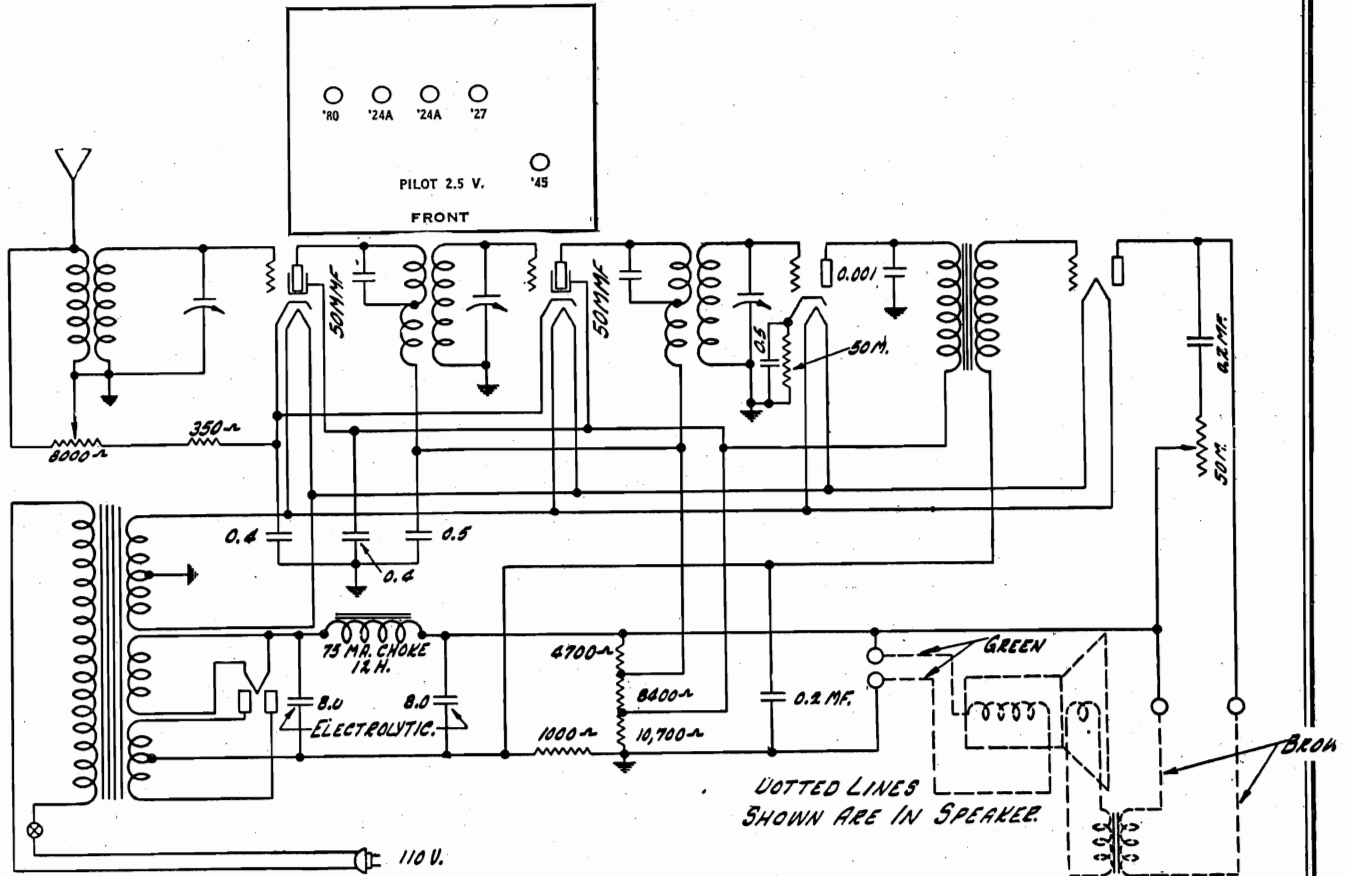

The 27W Chassis uses the following tubes:
 2—224's as R.F. Amplifiers,
 1—227 as Detector,
 1—245 as Audio Amplifier,
 1—280 as Rectifier.

The two stages of screen grid R.F. amplification in conjunction with the tuned antenna stage of this chassis give a sensitivity averaging 10 Microvolts per meter while the 227 power detector used with the single stage high gain audio provides good power output, with excellent tone quality.

Volume Control

The 8000 ohm volume control is connected across the antenna and ground of the input stage. The movable arm of the volume control is connected to ground in series with the cathodes of the two 224 R.F. amplifier tubes. This method of connection gives us a dual volume control action, which varies the signal input to the antenna stage as well as the grid bias on the first two R.F. tubes. The volume control may be easily tested by taking the voltage readings from the cathode of the 224's to the ground connection and at the same time, varying the volume control. This will give an indication if the volume control is controlling the grid bias properly.

The R.F. transformers in the R.F. stages are the same as those used in the 32W and 26W chassis. The cathode, screen grid, and plates of the R.F. tubes are bypassed by the 964A bypass condenser.

The Power Detector

The power detector receives its grid bias from the voltage drop across the 50M cathode resistor (Part No. 1892). The plate of the detector is bypassed to ground through the .001 M.F. R.F. plate bypass condenser.

The audio stage consists of a high ratio audio transformer of special design. The secondary of this transformer connects directly to the 245 power tube. The audio transformer may be tested with the continuity meter of your set checker. Disconnect the primary and secondary leads from the chassis before taking continuity measurements. Test the primary and secondary for opens or shorts, and also take continuity readings between the primary and secondary terminals, and ground. There should be no readings between these terminals and the core of the transformer or chassis ground.

The tone control is connected across the primary of the output push pull transformer, and consists of 50M variable resistance in series with a .2 M.F. fixed condenser. A short in this condenser will short circuit the primary of the speaker transformer and no signals will reach the loud speaker.

The power supply of the 27W chassis is similar to that used in some of our other chassis previously described.

Two electrolytic condensers are used in the filter circuit and care must be taken that these chassis are always kept in an upright position to prevent any small amount of electrolytic leakage in the filter condensers. It is a good idea to inspect the electrolytic condensers, upon delivery of any sets, and to wipe the top perfectly dry.

25 Cycle Chassis No. 27WX

This chassis uses a 25 cycle power transformer. Otherwise the constants of the circuit are the same.

MODEL 2655, AE-10
Voltage-Data
Two Types

MONTGOMERY-WARD & CO.

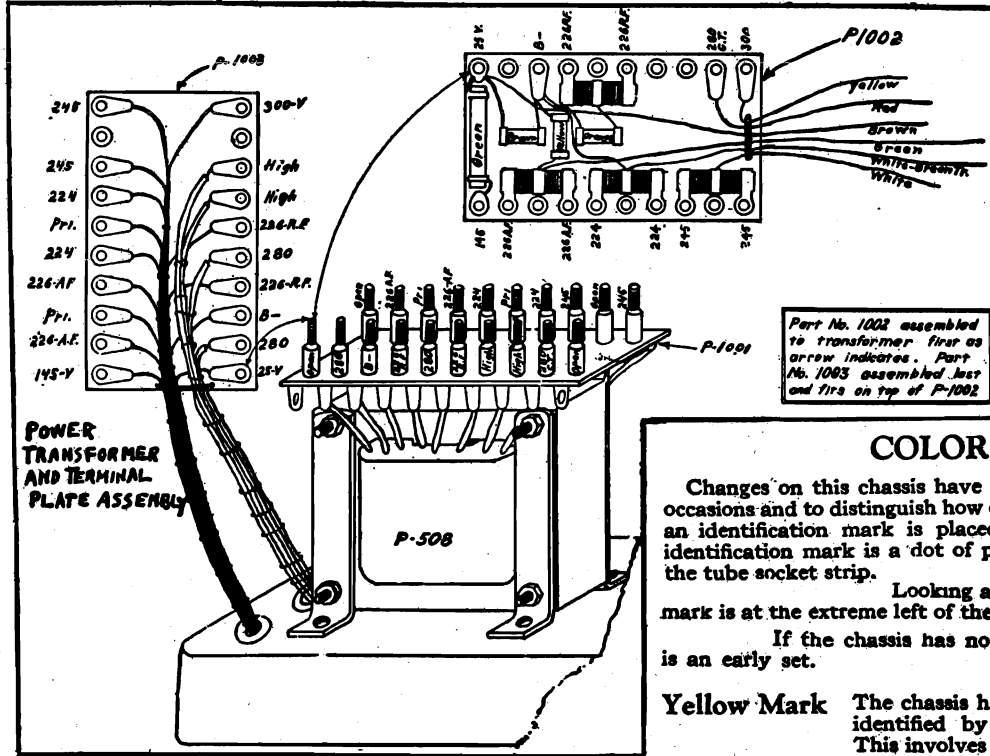

OPERATING VOLTAGES

Type of Tube	Position of Tube	TUBE IN TEST SET							Grid Test Ma.
		"A" Volts	"B" Volts	Control Grid ("C") Volts	Screen Volts	Screen Current	Cathode Volts	Normal Ma.	
226	1st R.F.	1.35	116	8.5				4.7	8.7
226	2nd R.F.	1.35	116	8.5				4.7	8.7
226	3rd R.F.	1.35	116	8.5				4.7	8.7
226	4th R.F.	1.35	116	8.5				4.7	8.7
224	Det.	2.2	80	1.3	15				
226	1st A.F.	1.4	110	1.0				4.0	5.0
245	2nd A.F.	2.2	232	42				27	32
245	2nd A.F.	2.2	232	42				27	32
280	Rect.	4.6							84

Line Voltage During Test—115 Volts

REVISION OF OPERATING VOLTAGES

Type of Tube	Position of Tube	TUBE IN TEST SET							Grid Test Ma.
		"A" Volts	"B" Volts	Control Grid ("C") Volts	Screen Volts	Screen Current	Cathode Volts	Normal Ma.	
224	Det.	2.2	75	1.3	15				
226	1st A.F.	1.4	77	1.0				4	5

200, 291, 292, 9950

(A.C.)

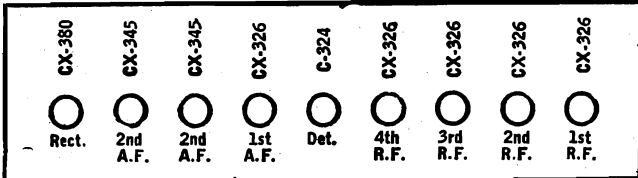

COLOR CODE

Changes on this chassis have been made on several different occasions and to distinguish how one chassis differs from another, an identification mark is placed on each one changed. This identification mark is a dot of paint found on the end rivet of the tube socket strip.

Looking at the chassis from the back the mark is at the extreme left of the 226 tube socket

If the chassis has no mark it is understood that it is an early set.

Yellow Mark The chassis having the first changes may be identified by the yellow indicating mark. This involves four changes.

1. A "dual volume control" in place of the single type. The new volume control is made in two sections, with five lugs. The section nearest the chassis, having two lugs, operates exactly the same as the single volume control. The section behind the first, having three lugs, is placed in the first audio circuit to reduce the audio amplification and operates in tandem with the antenna volume control.

2. An interchange of position of the two audio transformers. The re-arrangement of the audio transformers has not altered their connections in the circuit.

3. An addition of a "dual half microfarad condenser" and two carbon resistors in the "B" circuit of the detector and first audio tubes. The 40,000 ohm black resistor with one section of the dual condenser is placed in the detector circuit (224) and the 15,000 ohm blue resistor with the other section of the dual condenser is placed in the first audio circuit (226). You will note that the yellow and blue leads in the cable connecting to the terminal strip have been interchanged.

4. A change in the location of the grounding of No. 1 lug on the condenser block. This lug is now grounded to the condenser case with a short piece of bare wire.

Red Mark (Serial Number 39,000-42,999)

All chassis having a red mark on the rivet of the tube socket strip have all of the changes mentioned above and in addition, have a one-tenth microfarad condenser connected from ground to one side of the 110 volt line

A peculiarity that may be experienced by the addition of this condenser is a loud hum on every station tuned in only when the antenna wire coming from the set is connected to ground. This can be eliminated by reversing the plug in the socket. Also be sure your antenna is not grounded, either by some other set being connected to your aerial or through any other means.

Green Mark (Serial Number 43,000 and up)

All Chassis with a green mark on the rivet of the tube socket strip contain the above changes and in addition have a change in the "combination phonograph switch" circuit. This changed circuit makes use of only the audio system of the set for phonograph reproduction, whereas the original circuit included the detector tube

The Phonograph, Radio, On, and Off positions of the switch are the same as in the early sets. To obtain maximum volume and best tone quality a pick-up coupling transformer should be used to match the pick-up used.

MONTGOMERY-WARD & CO.

MODEL 2822, 2827

Balboa

2895, 2897

DeSoto

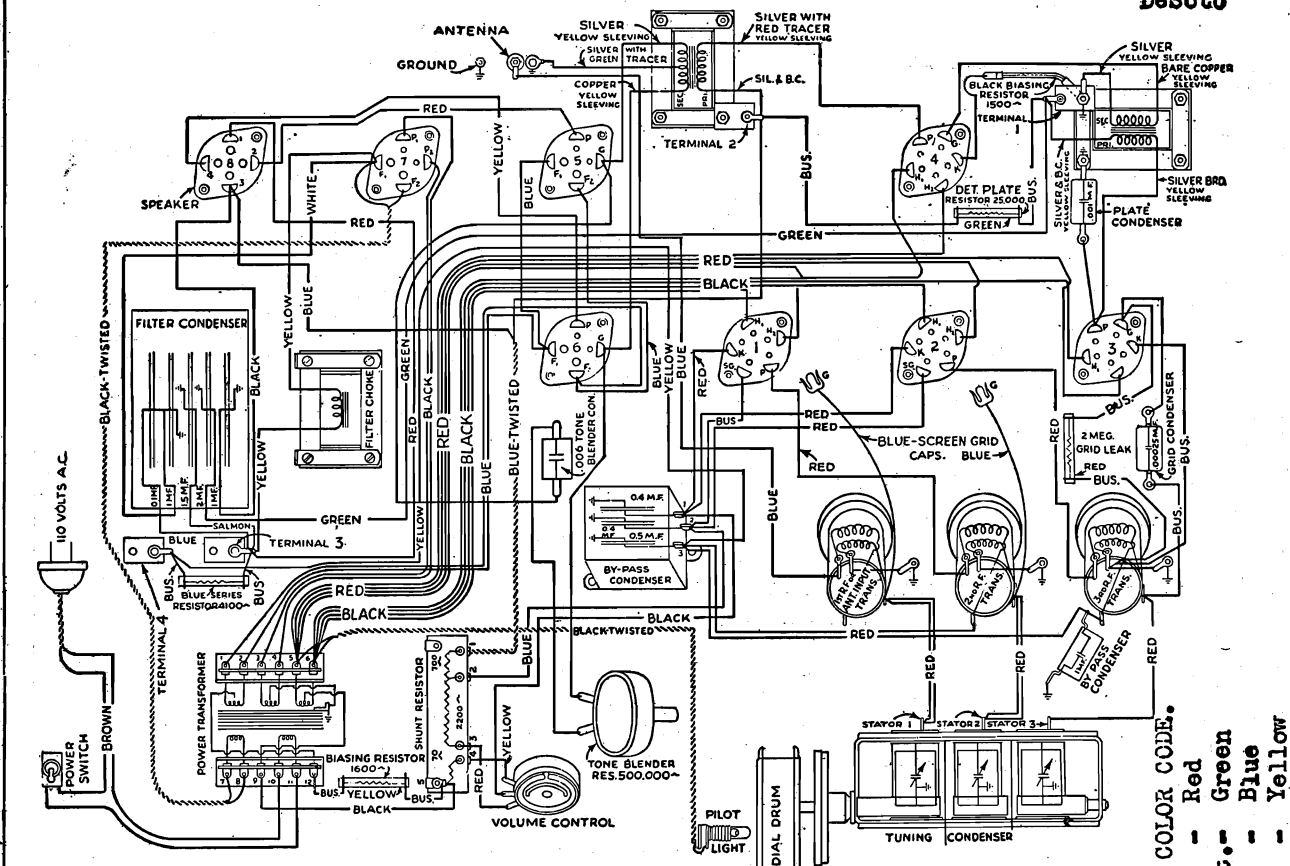

RESISTOR COLOR CODE.
 - Red
 - Green
 - Blue
 - Yellow

2 Meg. grid leak
 25,000 ohm resist.
 4100
 1600

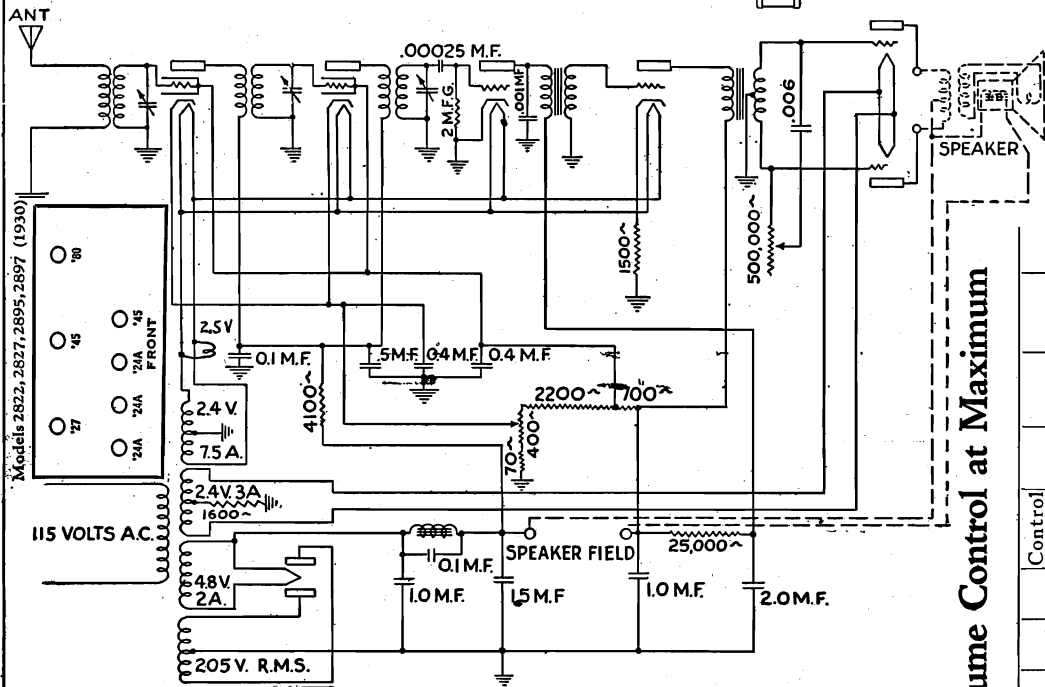

Volume Control at Maximum

Type of Tube	Position of Tube	"A" Volts	"B" Volts	Control "C" Volts	Screen Volts	Screen Current	Cathode Volts	Plate MA
224	1	2.36	173	2.72	86	.87	2.72	3.0
224	2	2.31	173	2.72	86	.21	2.72	3.0
227	3	2.28	38	0			0	2.8
227	4	2.28	100	6.1			6.1	3.25
245	5	2.29	169	38			11.3	11.3
245	6	2.29	169	38			11.3	11.3
280	7	4.61					34.5	34.5
							Per Plate	1600

No. 2897 and 2827

This chassis is the same as the 60 cycle chassis just described with the exception of the power transformer, the filter choke and an additional .4 M.F. condenser which is connected across the .1 M.F. condenser of the filter choke. The 25 cycle chassis will operate satisfactorily on 60 cycles if the .4 M.F. choke condenser is removed, however, the 60 cycle chassis cannot be used on 25 cycles.

SECTION SHOWN WITH DOTTED LINES IS IN SPEAKER

MONTGOMERY-WARD & CO.

MODEL 11,000
Challenger
Schematic
Two Types

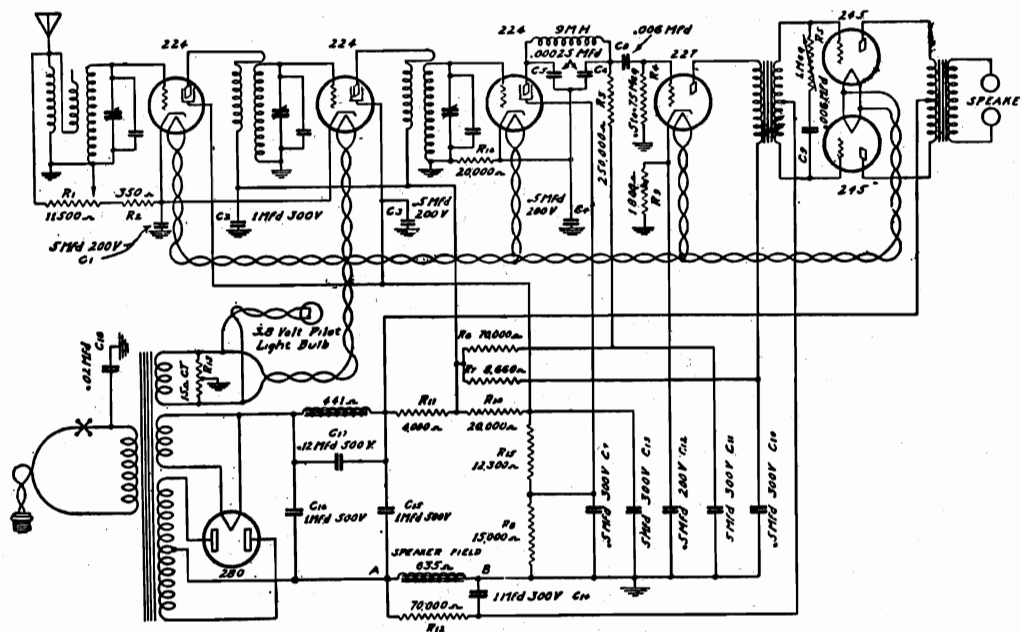

Schematic Diagram of Challengers with Serial Number Above A94313.

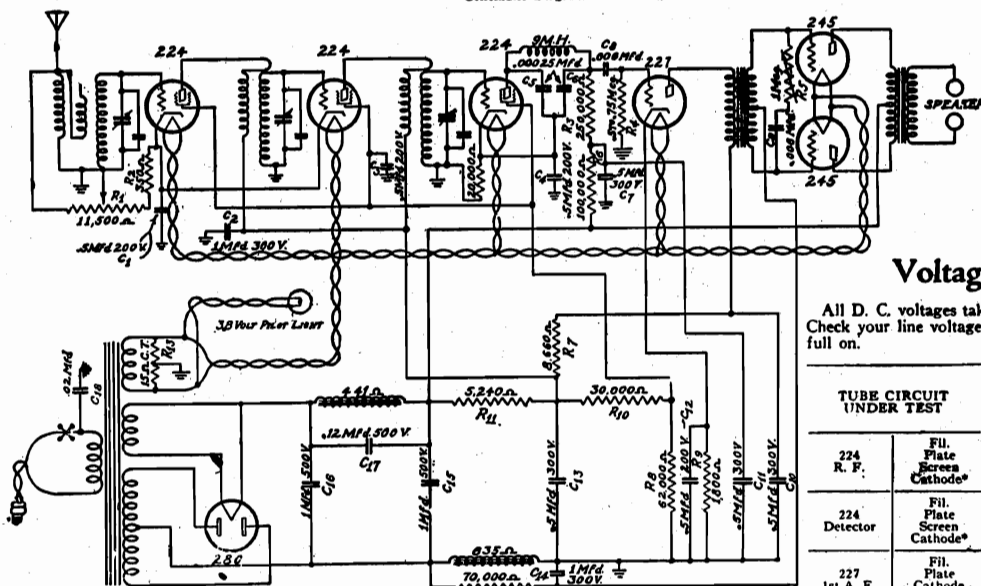

Schematic Diagram of Challengers with Serial Number Below A94313.

Voltage Characteristics

All D. C. voltages taken with a 1,000 ohm per volt voltmeter. Check your line voltage before taking readings. Volume control full on.

TUBE CIRCUIT UNDER TEST		LINE VOLTAGE				
		90 V.	100 V.	110 V.	120 V.	130 V.
224 R. F.	Fil.	1.75	1.95	2.17	2.3	2.57
	Plate	130	150	169	183	193
	Screen Cathode*	68	78	86	94	100
224 Detector	Fil.	2.0	2.43	2.83	3.2	3.6
	Plate	1.77	1.97	2.19	2.33	2.6
	Screen Cathode*	35	40.8	45.5	50.5	55
227 1st A. F.	Fil.	37.5	43	48	52	56.8
	Plate	2.55	3.1	3.65	4.2	4.8
	Cathode*	1.79	1.99	2.22	2.34	2.62
245 2nd A. F.	Fil.	95	108	118	122	138
	Plate	5.7	6.7	7.5	8.4	9.3
	Grid	1.8	2.0	2.23	2.35	2.62
280 Rect.	Fil.	180	210	233	255	280
	Plate	-35	-42.3	-49	-55	-62
	Current	3.66	4.1	4.55	4.8	5.35
		54 ma	64 ma	73 ma	82 ma	90 ma

* Control grid voltages on the 224 tubes are measured from cathode to ground.

R.F. Coils

The antenna coil in particular is a departure from the usual performance of antenna stages in other receivers. With the usual commercial type of antenna circuit, a short antenna will detune the antenna stage and reduce the sensitivity of the set accordingly. The antenna stage in this set is so constructed that it will not be affected by short or long antennas to any appreciable extent. The R.F. coils in each stage are marked with a color, according to the group in which they fall, and three coils of the same color are placed in the chassis. This color marking is a streak of paint inside the secondary coil inside the lugs. In ordering coils for replacement, be sure to mention the color of the paint on the coil so that the replacements will be of the same characteristics. If in doubt, return the coils.

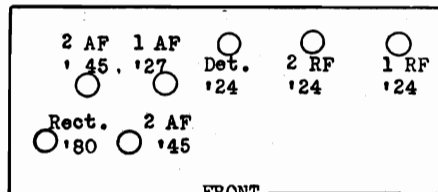

MODEL 14,000
Commander
62,000
Cavalier

MONTGOMERY-WARD & CO.

Models 3145, 14000, 26000 (1930)

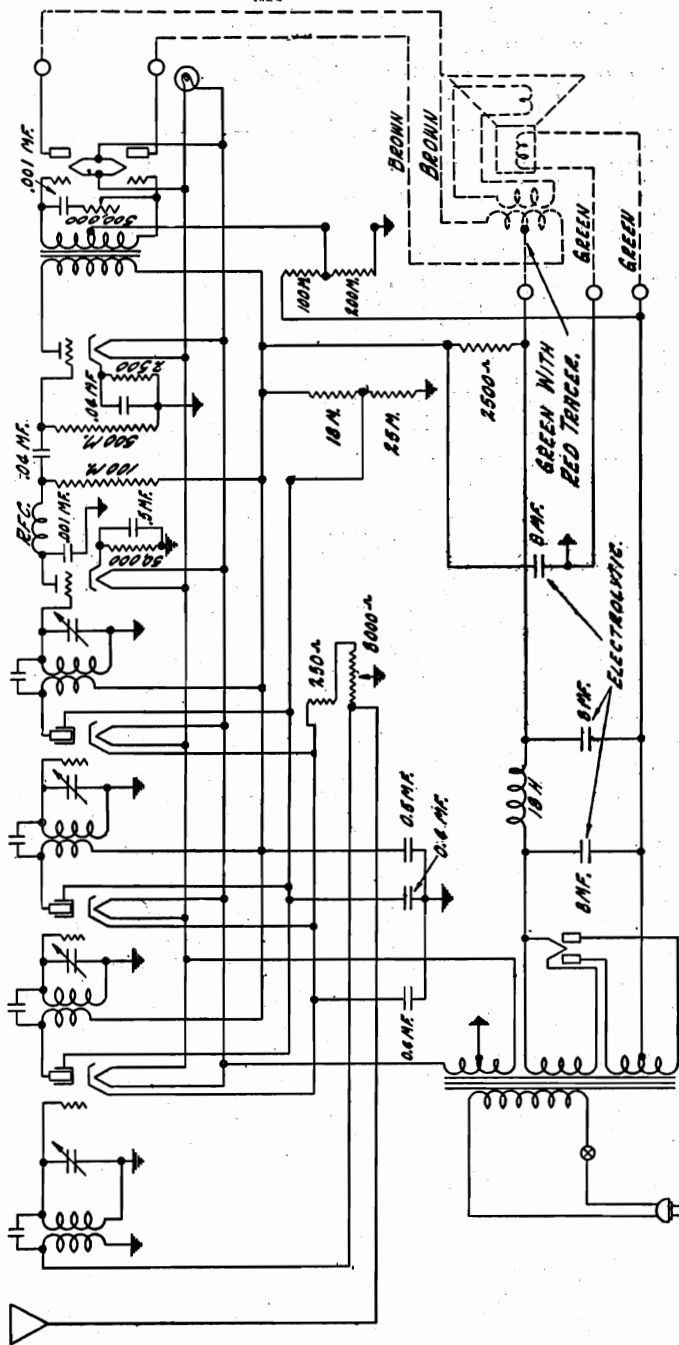
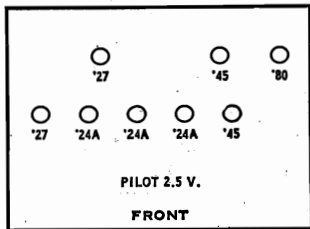

Schematic Diagram of Commander and Cavalier Sets *DOTTED LINES SHOWN ARE IN SPEAKER.*

Model 29 W chassis used in both the Commander and Cavalier sets is similar in all essential respects to the Airline Cortez and Coronado.

Certain changes have been made, however, which have to do chiefly with the operating voltages. The schematic diagram as compared with the diagram of the Cortez will show clearly where these changes have been made, and the operating voltages chart will show the effect that the changes have had in the voltages at the various tube sockets. In performance this chassis is quite similar to the Cortez, with the exception of slightly less power out-put when operated with the volume control full on.

Servicing instructions which apply to the Cortez also apply in the 29 W chassis. Do not forget, however, that in making any measurements with the set analyzer on the 29 W chassis, that the voltages are widely different from those used in the Cortez.

For "CORONADO" NO 3035 (60 ~) & 3037 (25 ~)
and "CORTEZ" NO 3065 (60 ~) & 3067 (25 ~)

Operating Voltages

VOLTAGES AT SOCKETS—VOLUME CONTROL AT MAXIMUM—LINE VOLTAGE, 115 PLUG IN SOCKET OF RECEIVER—TUBE IN TEST SET

Type of Tube	Position of Tube	Function	A Volts	B Volts	Control Grid Volts	Screen Volts	Screen MA	Cathode Volts	Plate M.A.	Grid Test M.A.
224	1	1st Radio	2.3	247	4.0	103	.75	4.0	4.6	9.3
224	2	2nd Radio	2.3	247	4.0	103	.75	4.0	4.6	9.3
224	3	3rd Radio	2.3	247	4.0	103	.75	4.0	4.6	9.3
227	4	Detector	2.3	160	17	15	17	15	3.5	4
227	5	1st Audio	2.3	243	15	15	15	15	5.9	6.9
245	6	2nd Audio	2.25	243	29.2	29.2	29.2	29.2	27.5	32
245	7	2nd Audio	2.25	243	29.2	29.2	29.2	29.2	27.5	32
280	8	Rectifier	4.9	243	29.2	29.2	29.2	29.2	27.5	32
						Per	Plate			42.5

MONTGOMERY-WARD & CO.

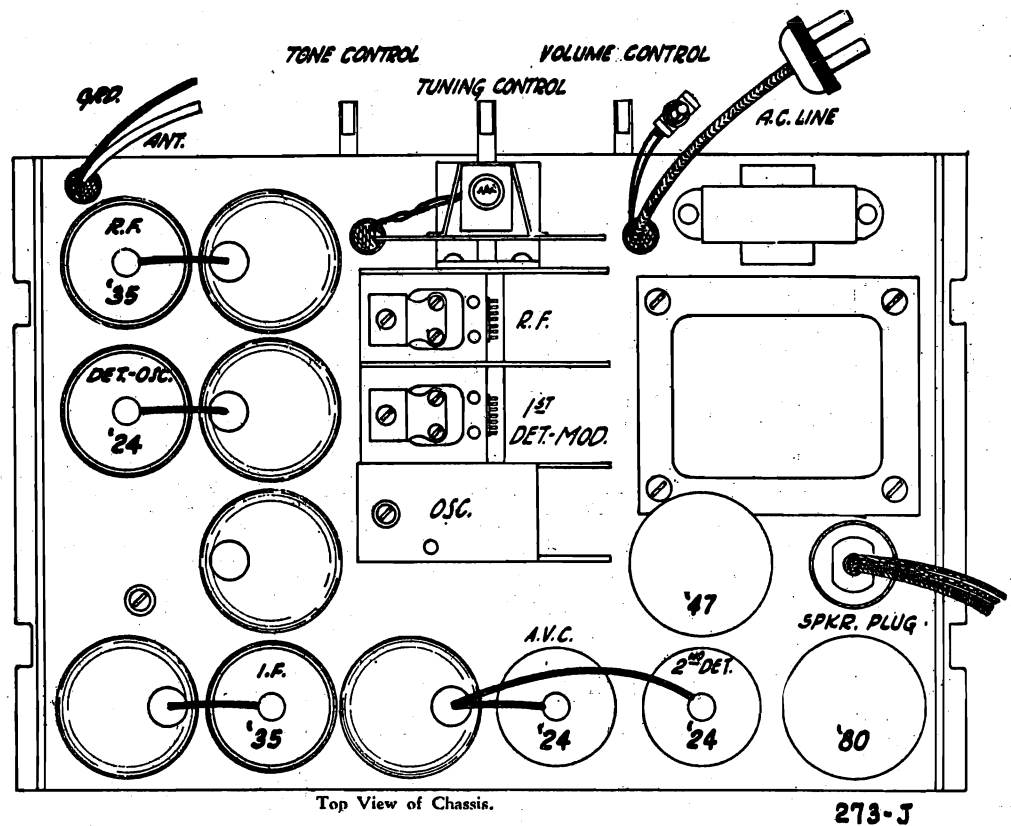
MODEL 62-20, 62-26
(62-25)Chassis
Data

I. F. and Oscillator Units

The primary and secondary of both intermediate transformers are tuned with adjustable condensers which remain fixed after the transformers have been tuned to exactly 175 kilocycles.

The oscillator 600 K.C. tracking condenser is mounted directly in front of the oscillator coil shield on the right rear corner of the chassis base.

Holes in the chassis base allow the tuning condensers for the intermediate transformers to be adjusted with a screwdriver from the under side of the chassis.

Power-Supply,

The 25 and 60 cycle power transformers are designed for operation on any 95 to 130 volt A.C. supply without adjustment and without overloading.

The 25 cycle chassis has a special power transformer and has two 8 mfd. 450 volt dry electrolytic condensers, in parallel, instead of the one condenser, C14, shown in the schematic diagram. An 8 mfd. 450 volt wet electrolytic condenser is mounted on top of the chassis base and this condenser replaces the condenser, C17, shown in the diagram. The 25 cycle chassis differs in no other way from the 60 cycle chassis.

Replacing Rubber Drive

You will note that the Vernier tuning drive on this chassis uses a rubber pinion. Under normal operating conditions this rubber will last for a number of years. Should it become worn it can be readily replaced by loosening the set screw of the brass bushing located next to the rubber pinion and pulling out the station selector shaft. Place a new bushing in position, slip the station selector shaft in place and tighten the set screw.

Automatic Volume Control (A.V.C.)

The action of the automatic volume control tube controls the grid bias on the R.F. and I.F. tubes and consequently the amplification of those tubes. The primary of the 2nd I.F. transformer has a tertiary winding which is connected in series in the A.V.C. tube grid circuit.

A signal of sufficient strength reaching the second detector, applies a voltage on the grid of the A.V.C. tube and the voltage thus applied depends upon the signal strength.

The plate of the A.V.C. tube will draw current when the grid voltage of the tube rises in potential and the drop in plate current is applied to the grids of the R.F. and I.F. tubes through their grid returns to the A.V.C. tube plate. This results in a control of the amplification of these tubes and a practically constant receiver output.

The manual volume control adjusts the negative biasing on the control grid of the A.V.C. tube, regulating in this manner the level of the input to the second detector at which the A.V.C. action commences. Thus the manual volume control behaves virtually as an output level control.

If the A.V.C. tube is defective or removed from its socket, there will be no control of the volume. Similarly, if the A.V.C. tube grid circuit is open, the plate of the tube applies a high grid bias on the R.F. and I.F. tube grids and practically no amplification is obtained from these tubes and consequently no receiver output.

A signal which is too weak to affect the A.V.C. tube grid voltage will not, of course, produce any change in plate current and the maximum amplification of the R.F. and I.F. tubes will be obtained, depending upon their grid bias as set by the A.V.C. tube plate.

MODEL 62-20,62-26X
(62-25)

MONTGOMERY-WARD & CO.

Schematic
Voltage

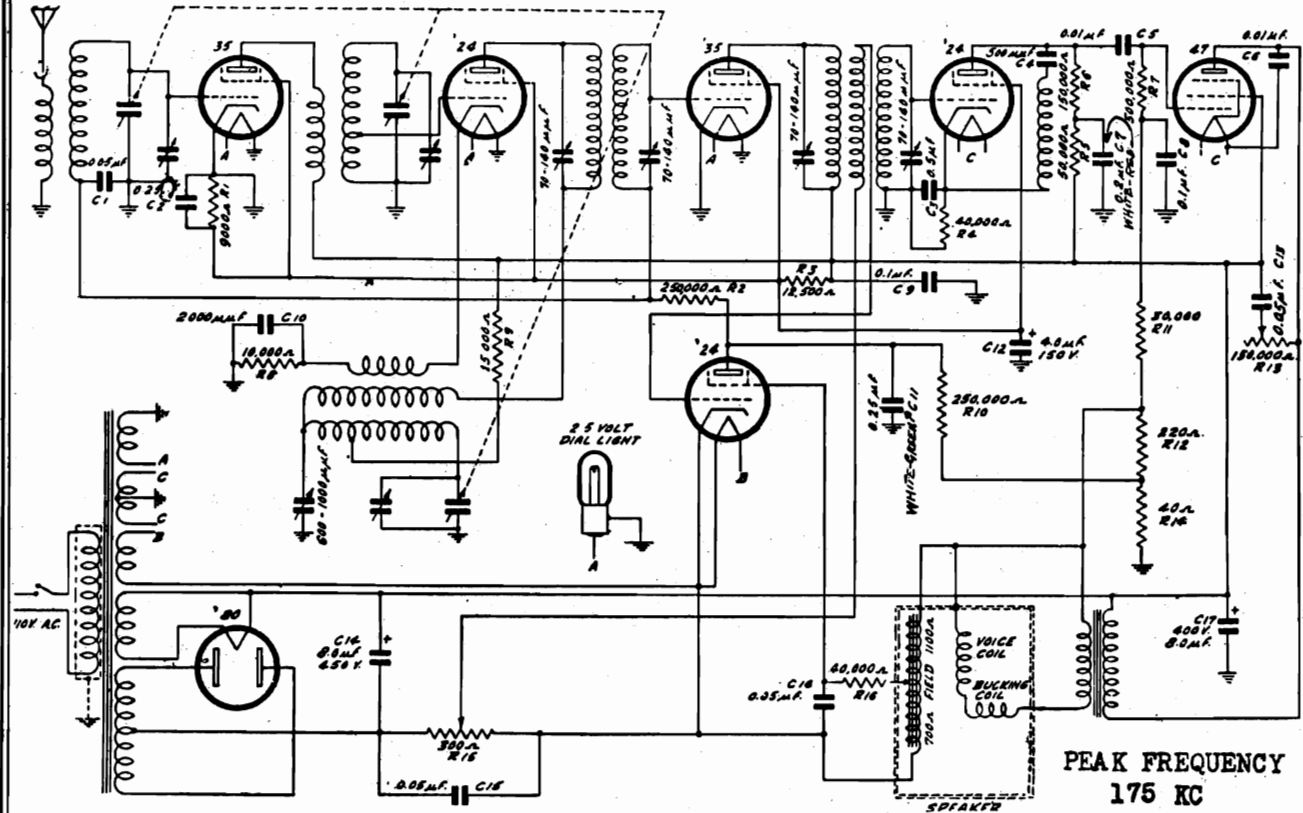

PEAK FREQUENCY
175 KC

TUBE	CIRCUIT	LINE VOLTAGE				
		90 V.	100 V.	110 V.	120 V.	130 V.
R. F. '35.	Screen-Grid	70	78	85	92	100
	Plate	192	213	234	256	277
Det.-Modulator '24.	Screen-Grid	70	78	85	92	100
	Plate	192	213	234	256	277
I. F. '35.	Screen-Grid	70	78	85	92	100
	Plate	192	213	234	256	277
2nd Detector '24.	Screen-Grid	70	78	85	92	100
	Plate	154	171	187	204	221
Audio '47.	Accelerating Grid	199	221	244	267	289
	Plate	181	200	220	240	260
A. V. C. '24.	Grid	12.3	13.7	15.1	16.5	17.8
	Screen-Grid	34.5	38.5	42	46	50
Rectifier '80.	Plate to Plate	308	342	376	410	445
	Current (both plates)	52.3 MA	58.1 MA	64 MA	69.7 MA	75.5 MA

TURN THE VOLUME CONTROL ALL THE WAY ON, CONNECT THE ANTENNA AND GROUND LEADS TOGETHER AND TURN THE GANG CONDENSER PLATES ALL THE WAY OUT. CHECK THE LINE VOLTAGE.

The voltages shown are measured to the cathode of the heater type tubes and to filament of the '47 Pentode.

OZARKA, INC.

MODEL Viking 5-A
MODEL S-5
MODEL S-7

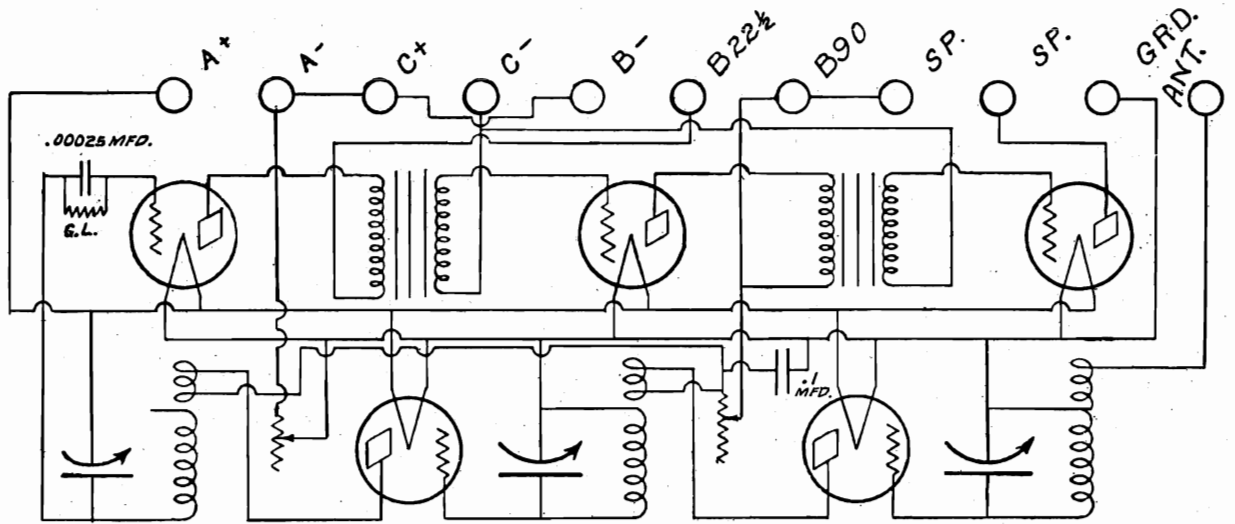

Model Viking 5-A

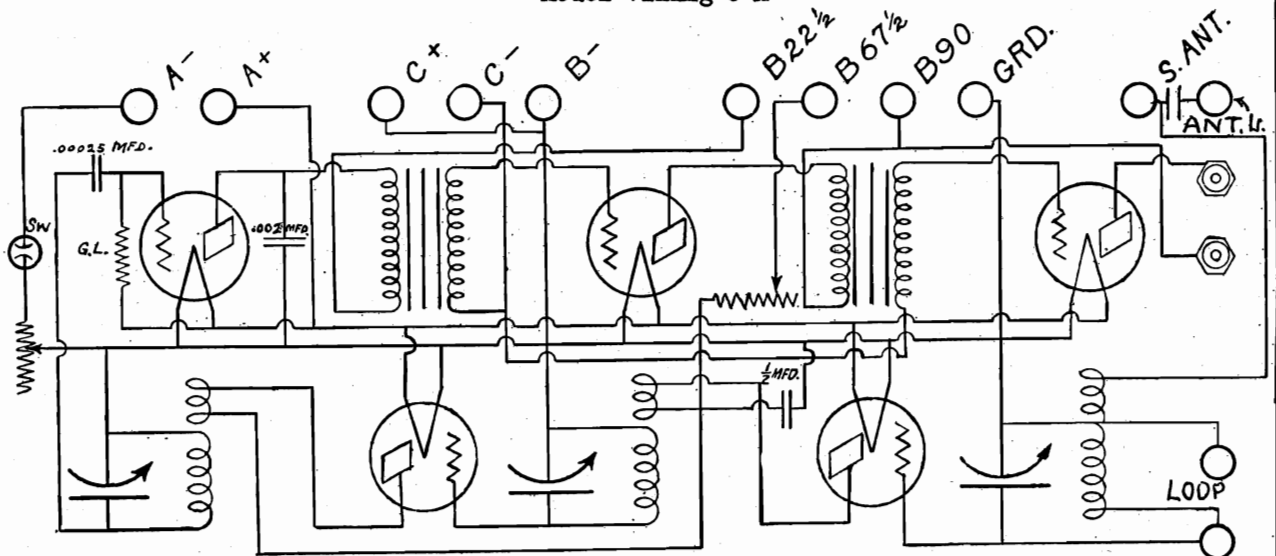

Model S-5

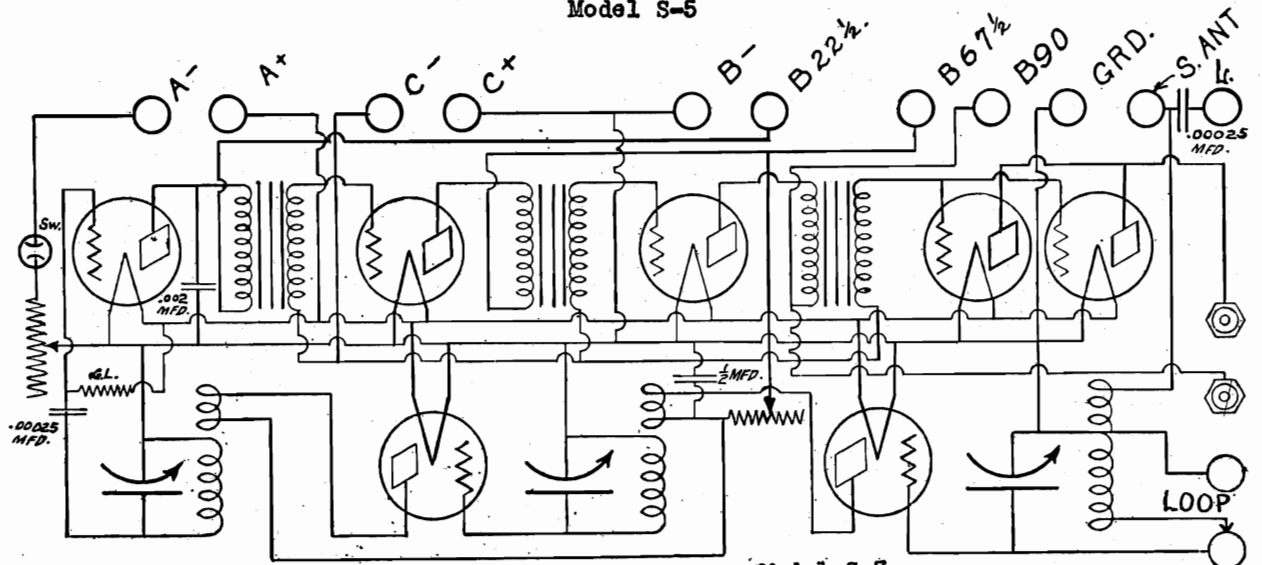

Model S-7

MODEL 78 Battery
MODEL 89 AC

OZARKA, INC.

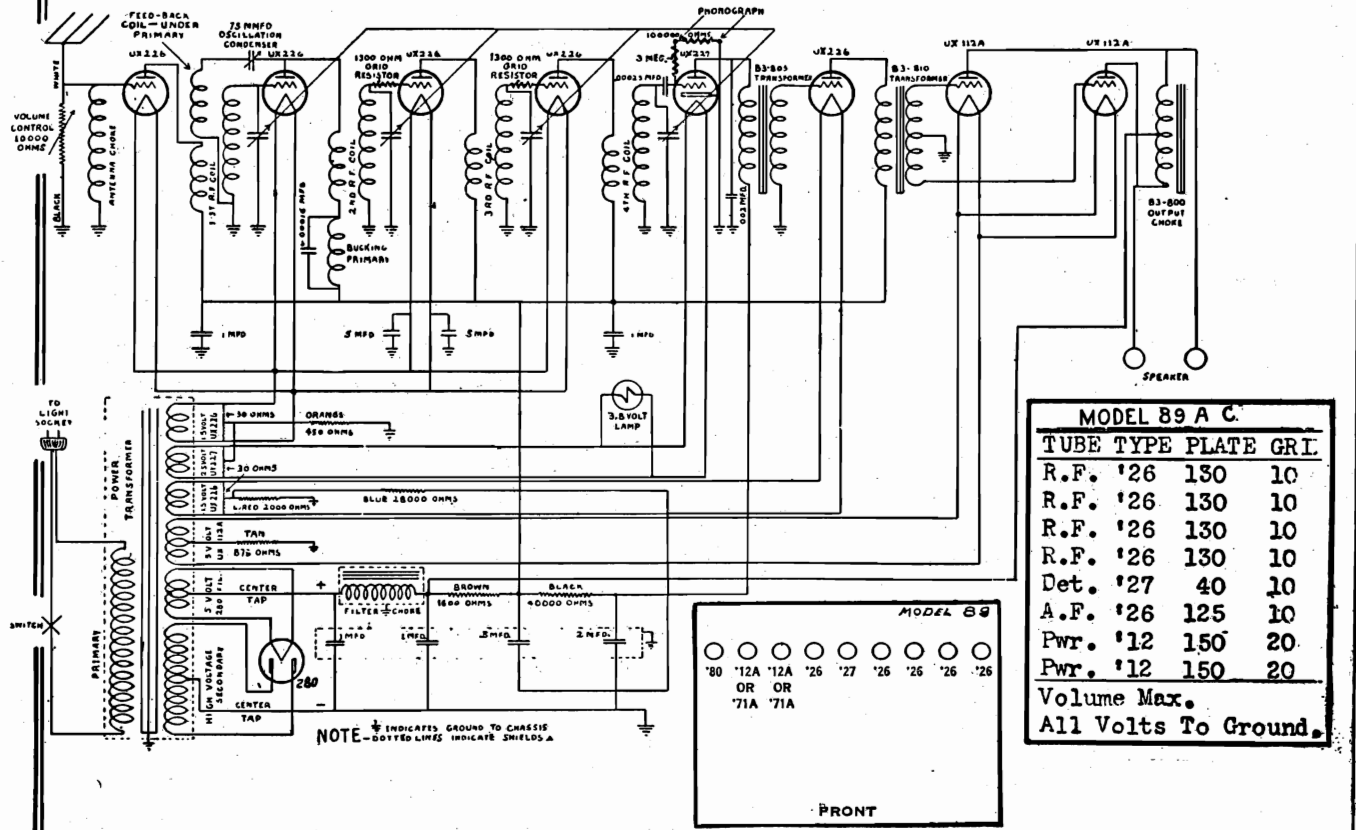
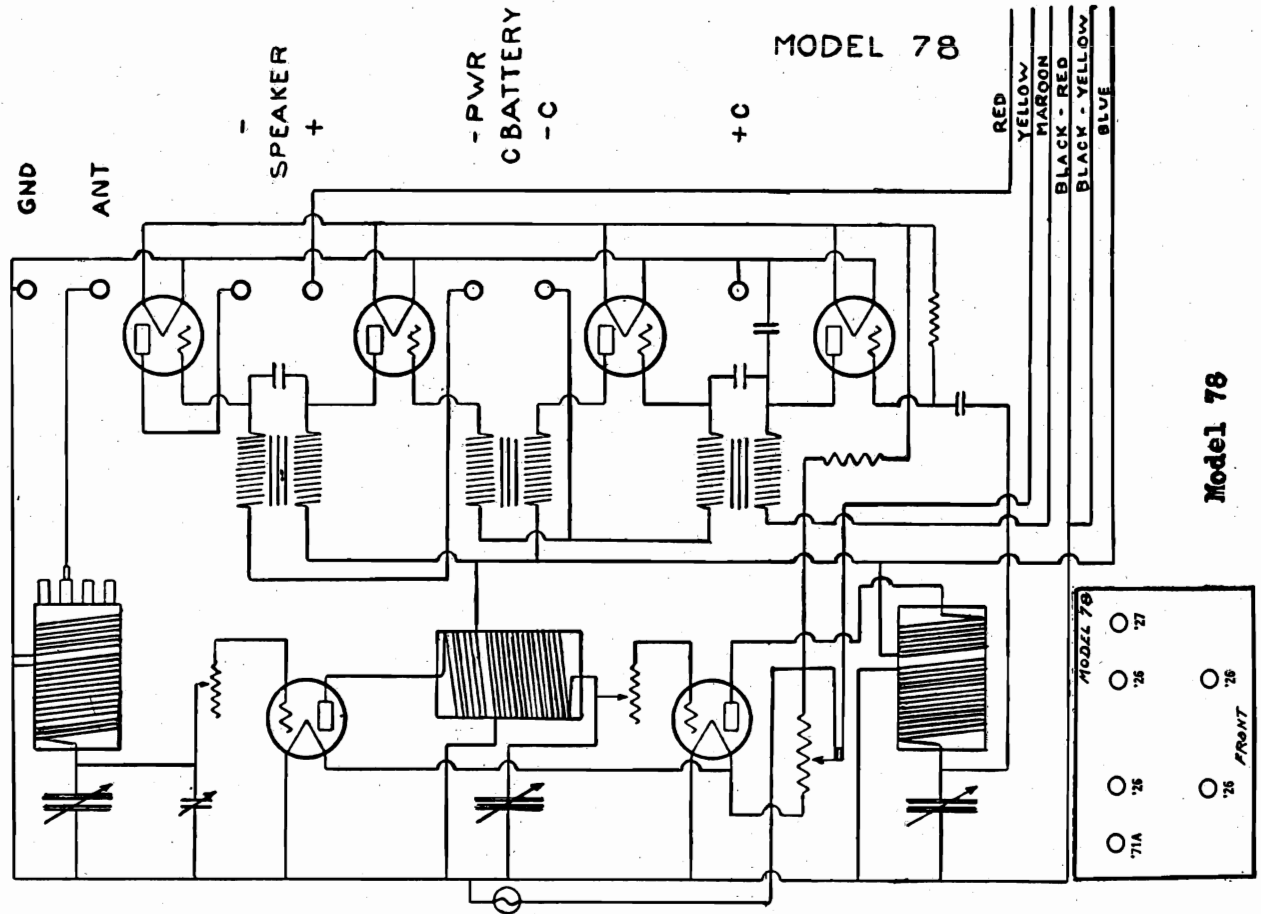

OZARKA, INC.

MODEL Short-Wave Converter
Schematic, Chassis Views

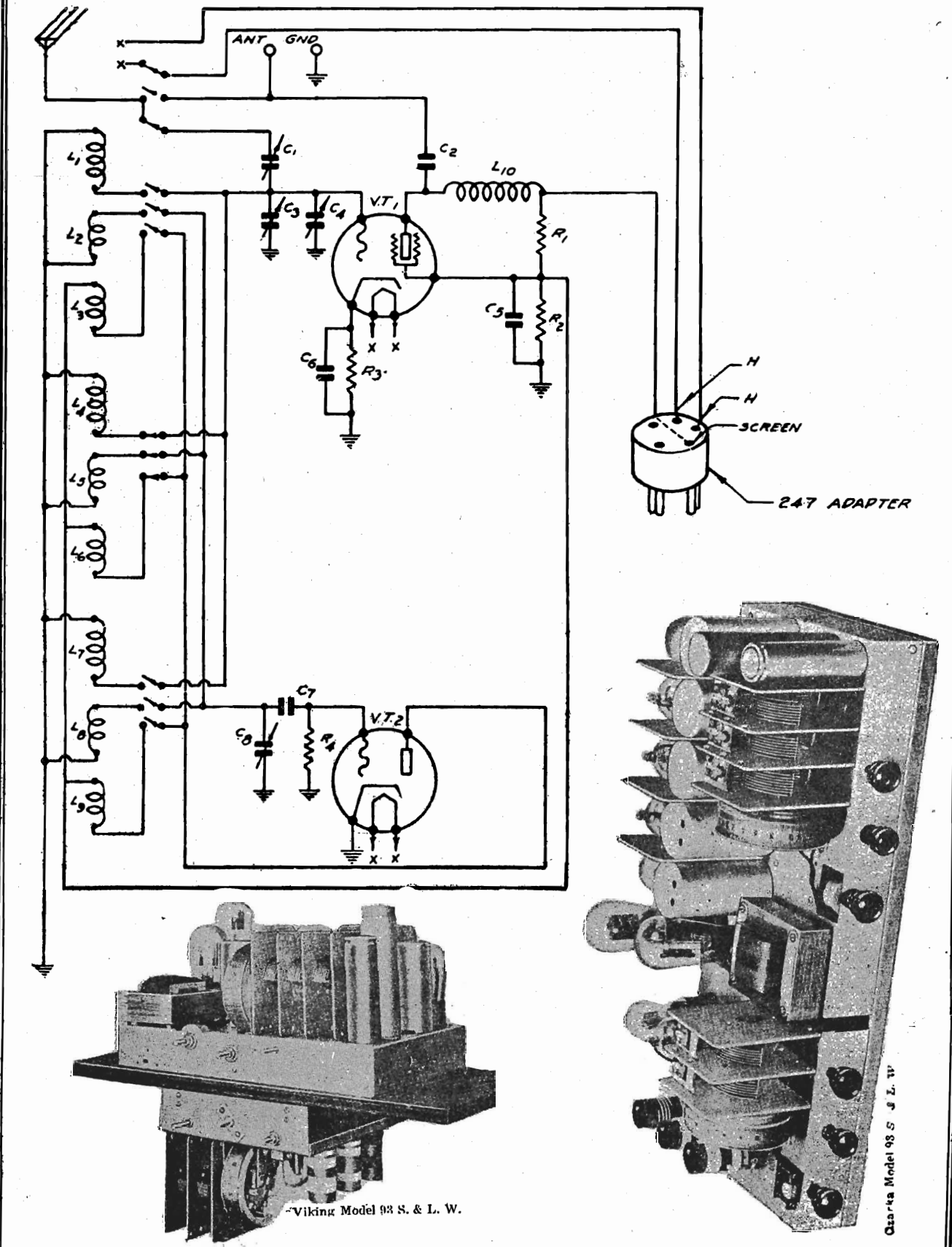

MODEL Viking 91 AC
Schematic, Chassis
Voltage

OZARKA, INC.

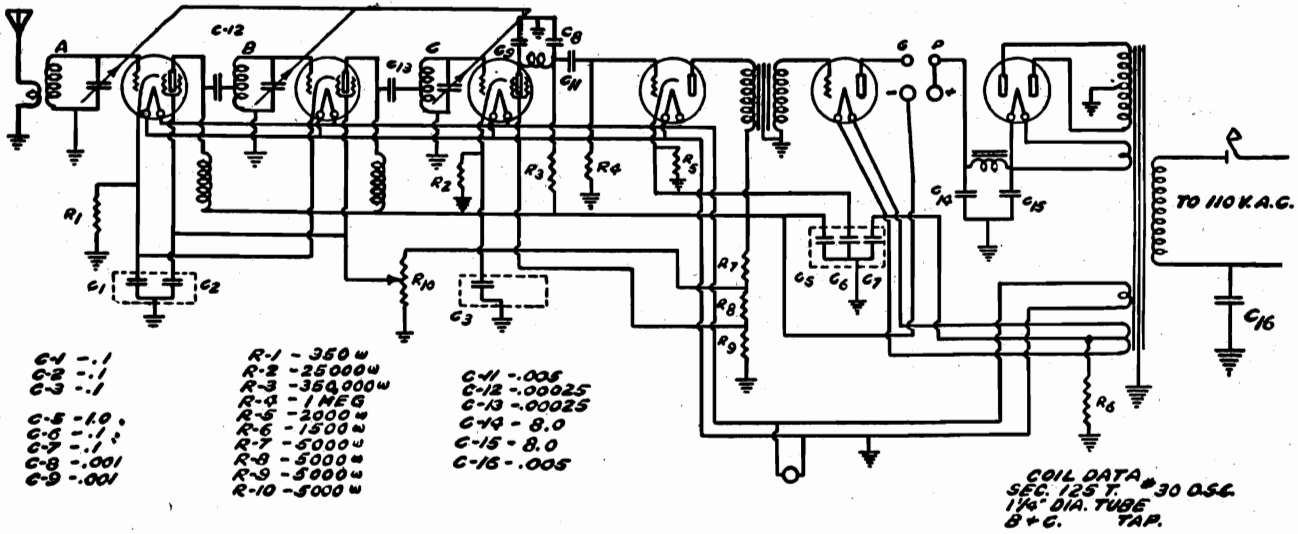

- C-1 - .1
- C-2 - .1
- C-3 - .1
- C-4 - .10
- C-5 - .1
- C-6 - .001
- C-7 - .001

- R-1 - 350 W
- R-2 - 25000 W
- R-3 - 350,000 W
- R-4 - 1 MEG
- R-5 - 2000 W
- R-6 - 1500 W
- R-7 - 5000 W
- R-8 - 5000 W
- R-9 - 5000 W
- R-10 - 5000 W

- C-11 - .005
- C-12 - .00025
- C-13 - .00025
- C-14 - 8.0
- C-15 - 8.0
- C-15 - .005

COIL DATA #30 OSG
SEC. 125 T
1 1/4" DIA. TUBE
B+C TAP.

MODEL VIKING 91

Tube	Type	Plate	Grid	Cath.
R.F.	'24	150	65	2
R.F.	'24	150	65	2
Det.	'24	50	30	3
A.F.	'27	145		47 (Grid)
Pwr.	'45	295		
Rect.	'80			
Volume Max.				
Voltages To Ground.				

Model 91 AC Viking

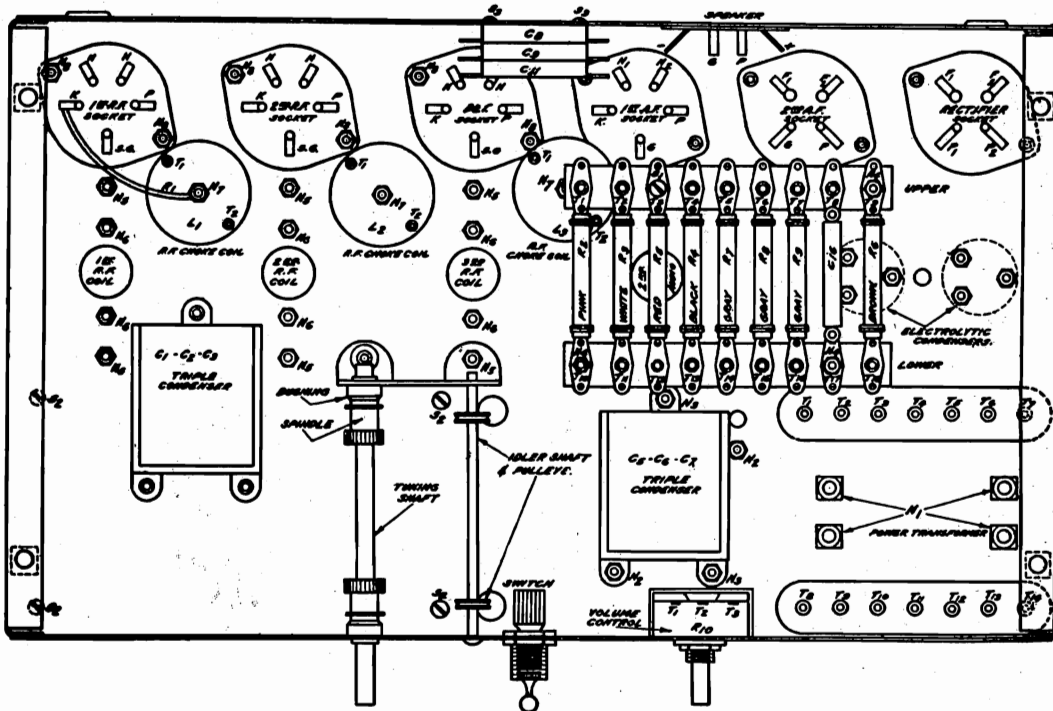
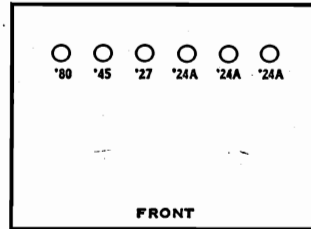

OZARKA, INC.

MODEL Viking 92 AC
Schematic, Chassis
Voltage

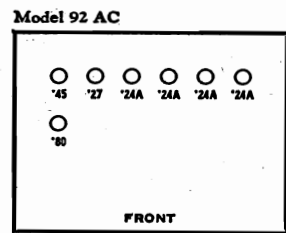
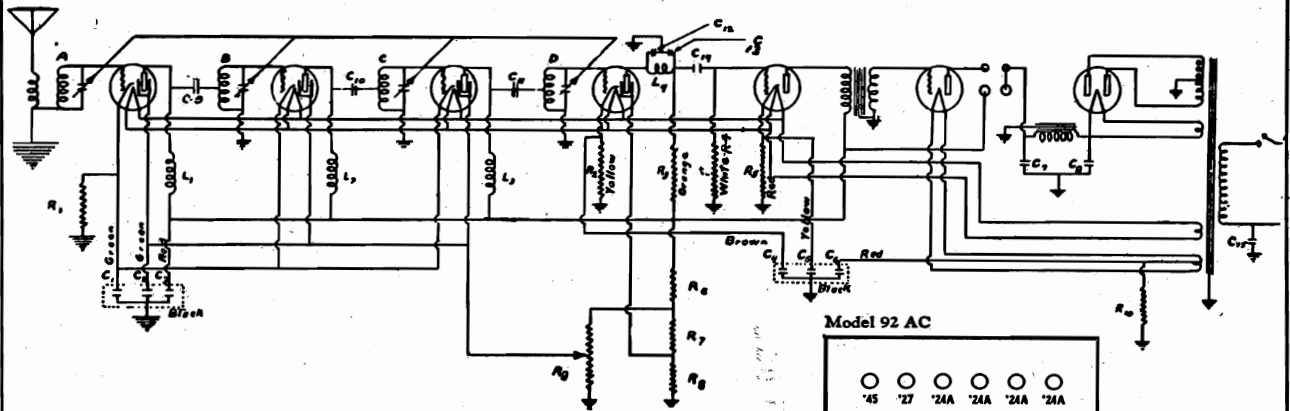

C1	.25	Mf. RF Bypass	R1	225 Ohms
C2	.25	" " "	R2	40,000 "
C3	1.0	" " "	R3	350,000 "
C4	.25	" AF "	R4	1,000,000 "
C5	.1	" " "	R5	2,000 "
C6	.5	" " "	R6	5,000 "
C7	8.0	" " "	R7	5,000 "
C8	8.0	" " "	R8	5,000 "
C9	.0001	" " "	R9	10,000 "
C10	.0001	" " "	R10	1,600 "
C11	.0001	" " "		
C12	.001	" " "		
C13	.001	" " "		
C14	.005	" " "		
C15	.005	" " "		

Tube Type	Plate	S. Grid	Cath.
R.F. '24	150	70	2
R.F. '24	150	70	2
R.F. '24	150	70	2.5
Det. '24	50	35	8
A.F. '27	140	--	50(Grid)
Pwr. '45	270	--	
Rect. '80			

Volume MAX. Voltages to ground.

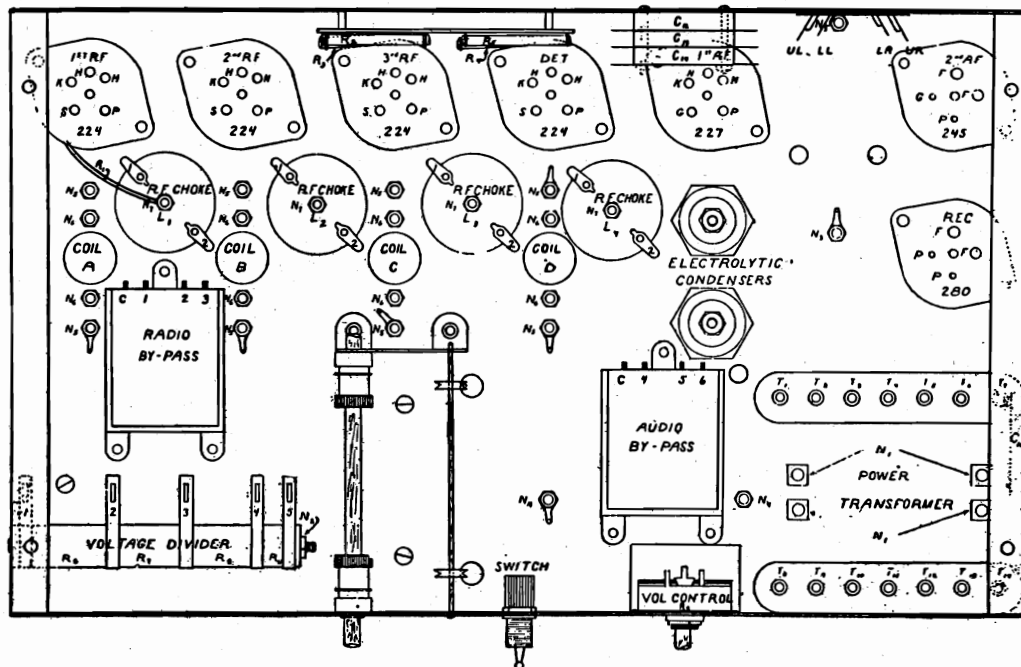

OZARKA, INC.

MODEL 93 Battery
Superheterodyne

MODEL 93 SUPERHETERODYNE (Battery)

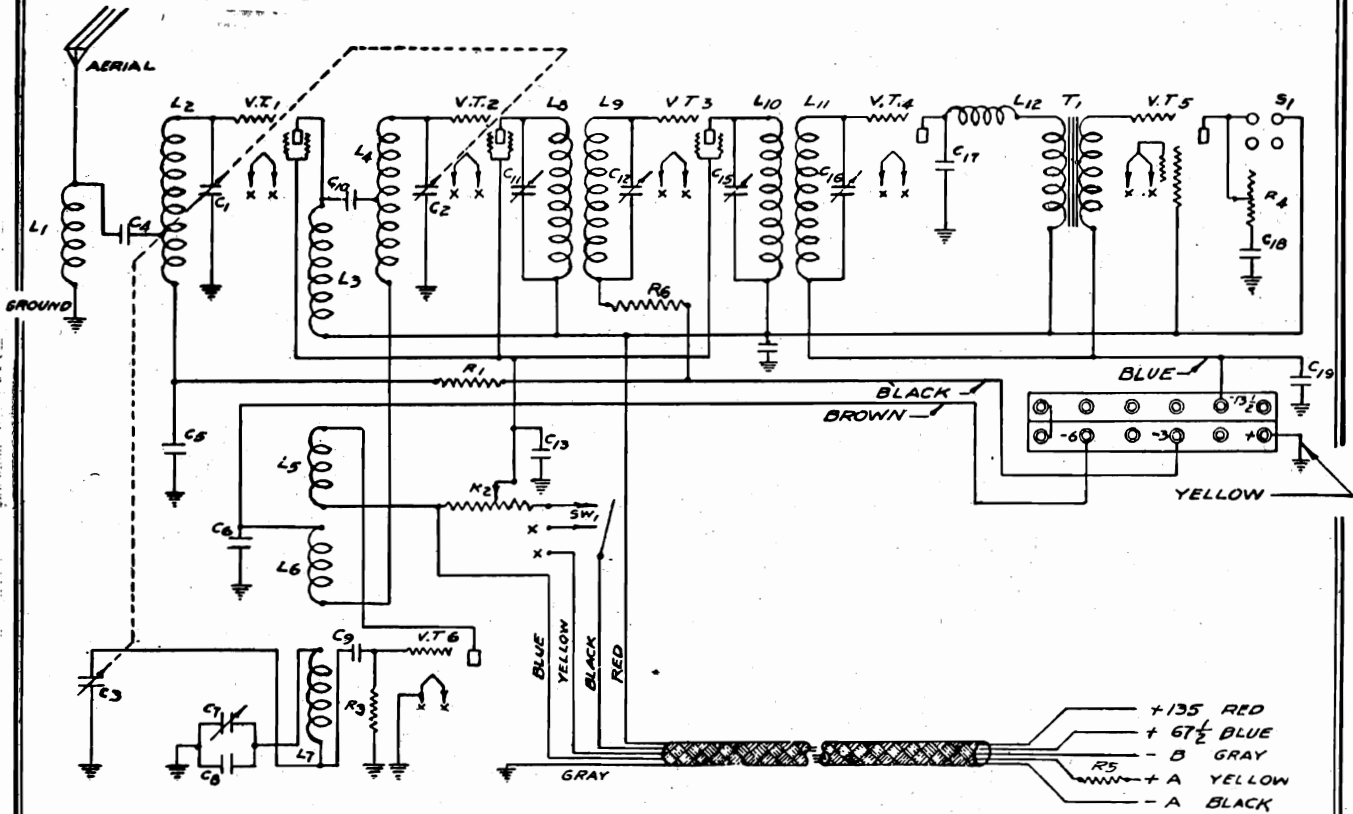

IF PEAK 175 KC.

Model 93 Battery

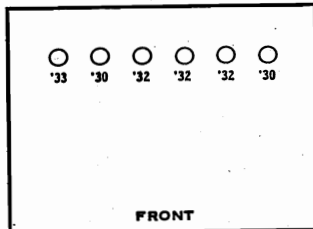

MODEL 93-A				
Tube	Type	Plate	S. Grid	Cath.
Osc.	'27	80	--	--
R.F.	'35	155	80	1.5
Det.	'35	155	40	2.
I.F.	'35	155	80	1.5
Det.	'27	125	--	13.
Pwr.	'47	182	200	
Rect.	'80			
Volume Max.		Volts To Ground.		
Diagram on page 458-B-7				

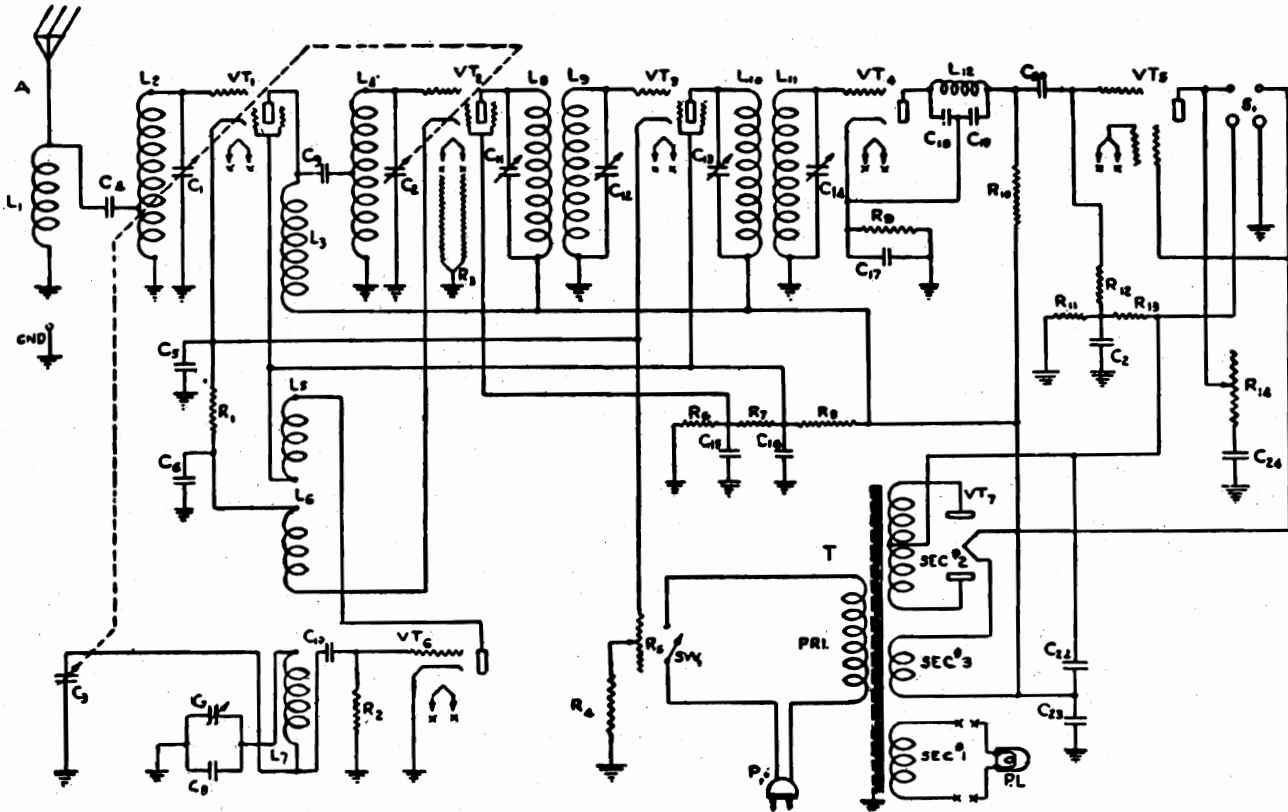

IF PEAK 175 KC.

Models 93A, 93B

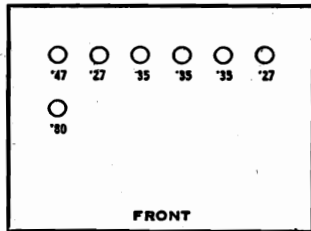

MODEL 93-B				
Tube	Type	Plate	S.Grid	Cath.
Osc.	'27	80	--	--
R.F.	'35	190	85	1.5
Det.	'35	190	45	2.
I.F.	'35	190	85	1.5
Det.	'27	125	--	12.
Pwr.	'47	175	190	
Rect.	'80			
Vol.-Max.				Volts To Ground.

MODEL 94-AVC

OZARKA, INC.

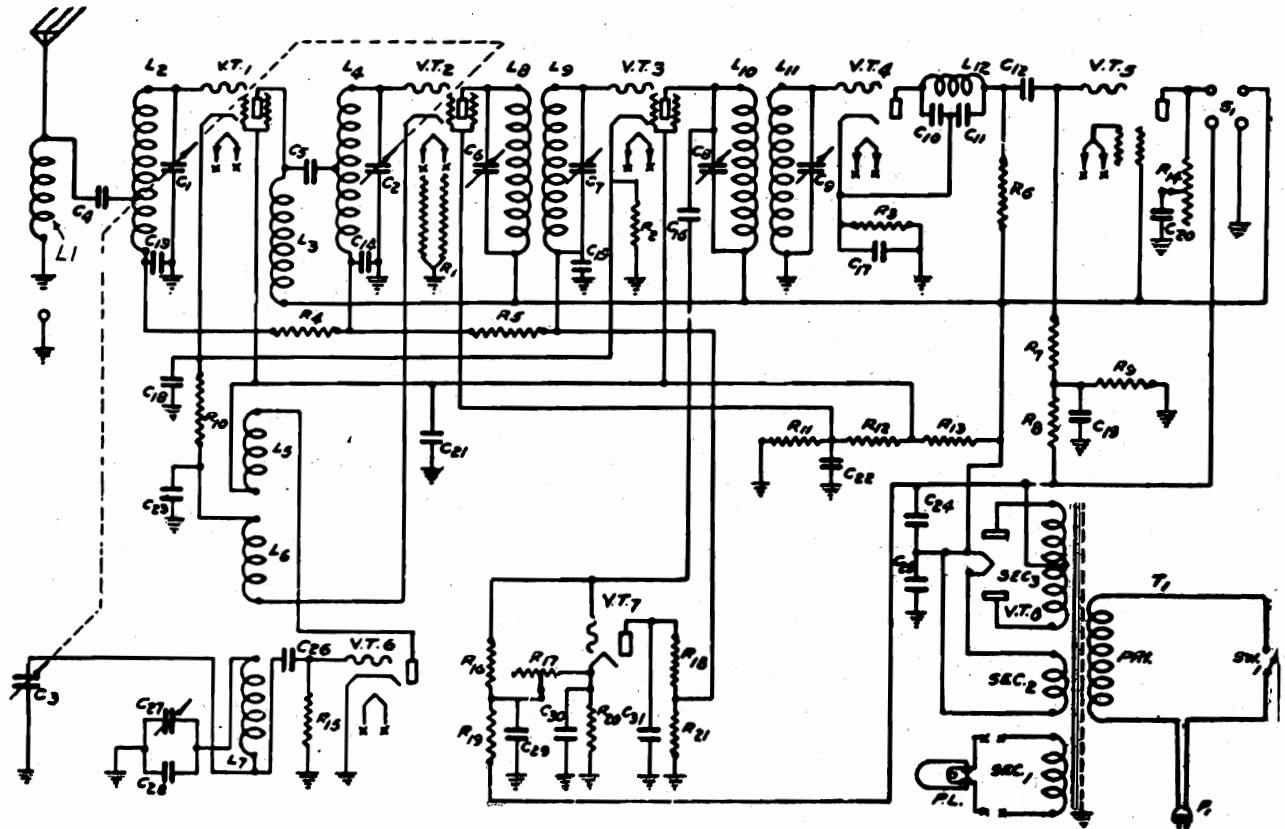

IF PEAK 175 KC.

Model 94A, 94B (A.V.C.)

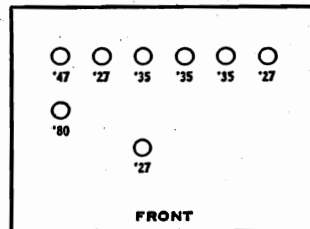

MODEL 94				
Tube	Type	Plate	S.Grid	Cath.
Osc.	'27	80	--	
R.F.	'35	190	85	1.5
Det.	'35	190	45	2.
I.F.	'35	190	85	1.5
Det.	'27	125	--	12.
Pwr.	'47	175	190	--
A.V.C.	'27			10.
Rect.	'80			
Volume Max.				Volts To Ground.

PHILCO RADIO & TELEVISION CORP.

MODEL 4
Alignment
Chassis

The adjustment of the compensating condensers in the Model 4 is done with the aid of a modulated oscillator, accurately calibrated at 3600KC. A high grade crystal controlled oscillator, of this type, Philco Model No. 091, can be obtained on order from the Philco National Service Station. The various harmonics and image frequencies of this signal are used to adjust the compensating condensers at the different short wave dial settings. If the oscillator is off frequency, the harmonics and image frequencies will be off correspondingly.

Remove the converter from its cabinet. Connect the Model 4 to the broadcast receiver in the usual manner, with the ground wire connected and the aerial disconnected. A Model 112 is preferable as this offers greatest sensitivity. It is important that the broadcast receiver be accurately calibrated at 1000KC and that the dial be set exactly at this point.

1. Adjusting at 3.6 megacycles on lower scale—Place the oscillator in operation and couple it with a wire to the antenna connection of the converter. Be sure that the oscillator is grounded. Set the dial at 3.6 megacycles on the lower scale and set the frequency control switch of the converter in its proper position. Carefully adjust the "3.6L" compensator shown in the illustration above, by means of a fibre wrench, Philco part 3164, until maximum signal is heard in the loudspeaker. It may be necessary to reduce the oscillator output by removing the oscillator from the coupling wire in order to obtain a faint input signal, the maximum strength of which can be readily determined by ear.

2. Adjusting at 1.6 megacycles—Set the dial at 1.6 megacycles and adjust the "1.5" compensating condenser in the same manner as described above.

3. Adjusting at 7.2 megacycles—Set the dial at 7.2 megacycles and set the frequency control switch in its proper position for the middle dial scale. Connect the oscillator output direct to the antenna terminal of the converter. Adjust the "8.5M" compensating condenser for maximum output in the loudspeaker as described above.

4. Adjusting at 3.6 on middle scale—Turn the dial to 3.6 on the middle scale and adjust the "3.6M" compensator as described above.

5. Adjusting at 18. megacycles—Set the dial at 18 and the frequency control switch in its corresponding position. Adjust the "19" compensator as described above. More than one signal will be heard as the adjustment is being made. Be sure to adjust for the one which is heard second as the compensating condenser capacity is reduced from its maximum (adjusting nut all the way in). When this adjustment has been made correctly, the oscillator signal can be heard at 18, 16, 14.4 and 12.4 megacycles. This adjustment is the most critical of any, and will require more care in getting the correct point.

6. Adjusting at 8.8 megacycles—Turn the dial to 8.8. Adjust the "8.5H" compensator in the manner described above.

RESETTING 1000KC WAVETRAP

A wavetrapp tuned to 1000 kilocycles is connected in the antenna circuit of the converter for the purpose of suppressing any possible interference from nearby stations which might be broadcasting at or near 1000 kilocycles. If it is impossible to find a point between 970 and 1070 KC at which interference is not heard, the wavetrapp should be re-adjusted by means of the fibre wrench until the interfering station is tuned out.

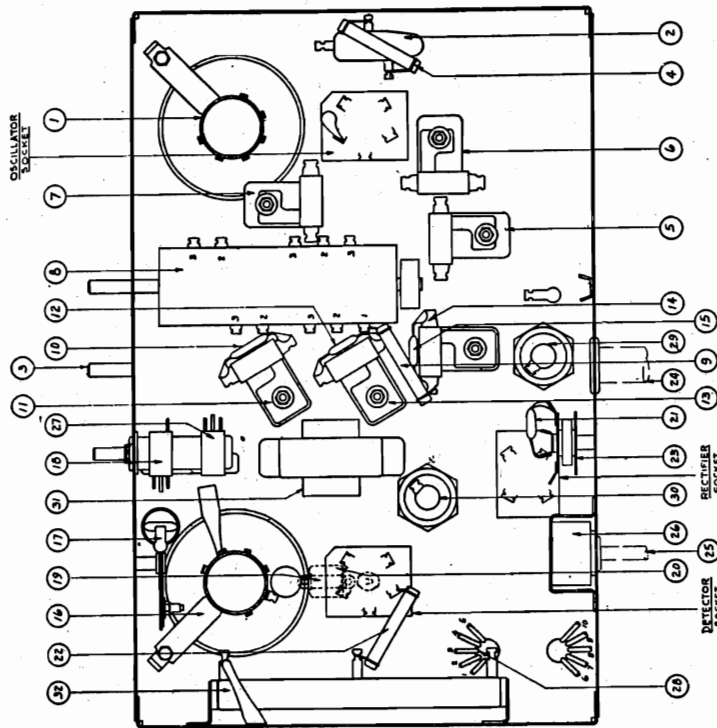

No. on Fig. 1 and 2	Description	Part No.
1	Oscillator Coil	02733*
2	By-pass condenser (.45 mfd.)	3615-M
3	Gang condenser	03692
4	Resistor (15,000 ohms)	3766
5	Compensating condenser (19 MC end of top scale)	04000-E
6	Compensating condenser? (8.5 MC end of center scale)	04000-E
7	Compensating condenser (8.5 MC end of bottom scale)	04000-E
8	Frequency control switch	03751
9	Resistor (240,000 ohms)	3768
10	Condenser (1250 mmf.)	5886
11	Compensating condenser (8.5 MC end of top scale)	04000-F
12	Condenser (800 mmf.)	5878
13	Compensating condenser (3.6 MC end of center scale)	04000-F
14	Compensating condenser (1.5 MC end of bottom scale)	04000-F
15	Condenser (250 mmf.)	3082
16	Detector transformer	03731
17	Frequency filter	09602
18	Antenna switch (assembled with 27)	5796
19	Resistor (2 Megohms) assembled with (20)	03879
20	Condenser (110 mmf.) assembled with (19)	03879
21	Condenser (250 mmf.)	3082
22	Resistor (99,000 ohms)	3767
23	R. F. choke	09103
24	Shielded cable	L-1278
25	Power cord and plug	L-943-A
26	Outlet receptacle	5439
27	"On-Off" switch (assembled with 18)	5796
28	Power transformer—50-50 cycles 25-40 cycles	5785
29	Electrolytic condenser (6 mfd.)	4916
30	Electrolytic condenser (6 mfd.)	4916
31	Filter choke (50-60 cycles)	4951
	Filter choke (25-40 cycles)	5930
	Resistor (two 32,000 ohms, 25-40 cycles)	3525
	Bezel	5175
	Cabinet	40600

*Includes matched oscillator coil and detector transformer.

PHILCO recommends that under no circumstances should any attempt be made to adjust the compensating condensers in the field, unless proper equipment is available, and that where such is not the case the unit should be turned over to a Philco Distributors Service Department. The adjustment is extremely critical and requires more time and patience than the ordinary broadcast receiver. All of the compensating condensers are accessible only from the bottom of the chassis. The short wave converter is accurately adjusted at the factory prior to shipment.

MODEL 4
Schematic
Voltage
Data

PHILCO RADIO & TELEVISION CORP.

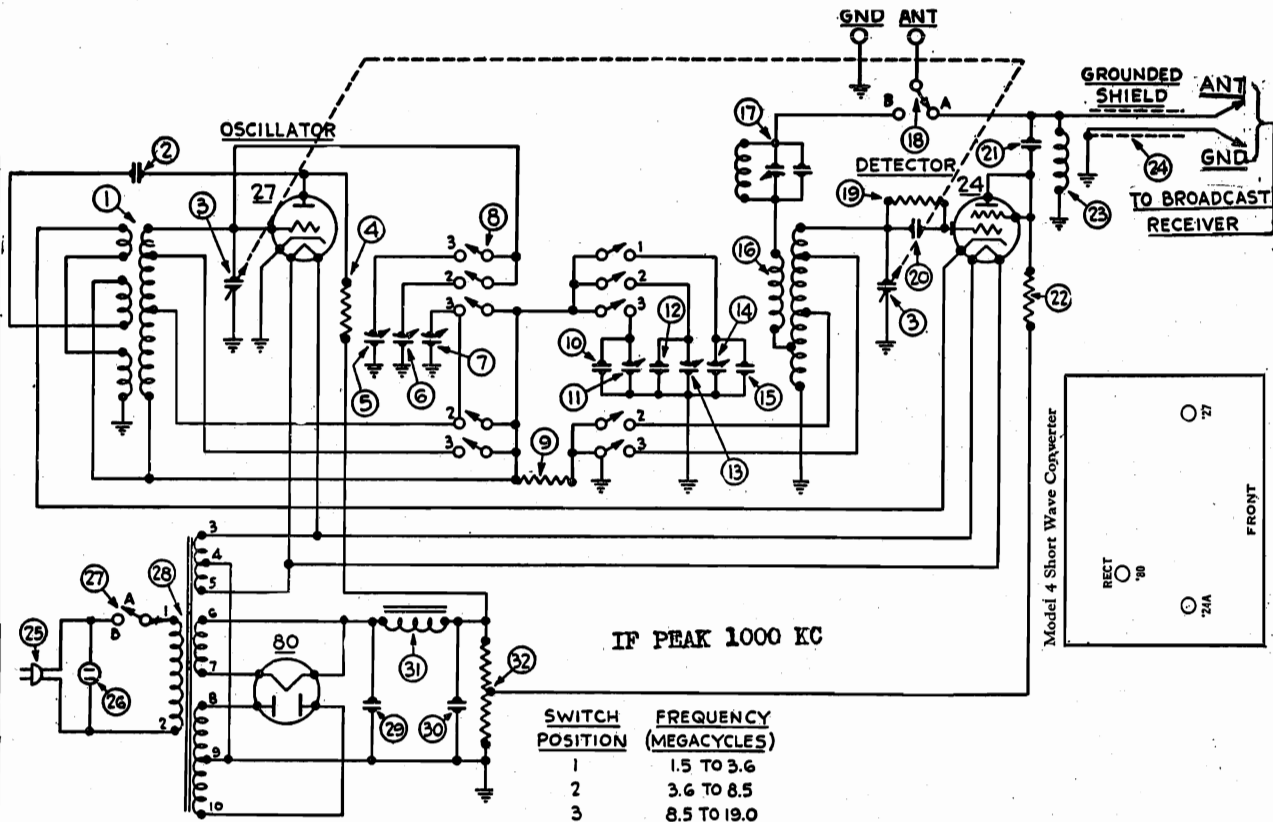

SWITCH POSITION	FREQUENCY (MEGACYCLES)
1	1.5 TO 3.6
2	3.6 TO 8.5
3	8.5 TO 19.0

Table 1—Tube Socket Readings—Line Voltage—115 volts

Tube		Filament Volts	Plate Volts	Screen Grid Volts	Control Grid Volts	Cathode Volts
Type	Circuit					
27	Oscillator	2.4	110	..	.1	0
24	Detector	2.4	25	25	.3	0
80	Rectifier	5.0	170/170

NOTE: The above voltage readings were taken from the socket terminals on the underside of the chassis, using a Weston multi-range voltmeter, 1000 ohms per volt. The radio set tester cannot be used either for voltage or plate current readings because of the effect of the long leads through the set tester cord.

Table 2—Power Transformer Voltages

Terminals	A. C. Volts		Color
1-2	105-125	Primary	White
3-5	2.5	Filament of 24 and 27	Black
6-7	5.0	Filament of 80	Light Blue
8-10	340	Plates of 80	Yellow
4	...	Center Tap of 3-5	Black with Yellow Tracer
9	...	Center Tap of 8-10	Yellow with Green Tracer

Table 3—Condenser Data

Nos. on Figs. 1 and 2	Capacity Mfd.	Container
20	.00011	Blue and Golden Yellow
12	.0008	Green and Orange
10	.00125	Blue and Orange
2	.05	Black Bakelite Container
22, 20	6.	Electrolytic

Table 4—Resistor Data

Nos. on Figs. 1 and 2	Power (Watts)	Resistance (Ohms)	COLOR		
			Body	Tip	Dot
22		4750	Long Tubular		
1	1.	4750			
22	1.	13000	Brown	Orange	Orange
2	1.	99000	White	White	Orange
6	.5	240,000	Red	Yellow	Yellow
10	.5	2 Megohms	Red	Black	Green

PHILCO RADIO & TELEVISION CORP.

MODEL 20, 20-A
Voltage
Values

Models 20 and 20-A Receivers

Model 20 Receivers are for Operation on 105-125 volt, 50-60 cycle AC Lines.
Model 20-A Receivers are for Operation on 105-125 volt, 25-60 cycle AC Lines.

Bulletin 28 covers the first few weeks' production of Models 20 and 20-A. These Receivers can be identified as having one or two compensating condensers. The later models have three compensating condensers fastened to the tuning condenser housing and are covered by Bulletin 36.

Table 1—Tube Socket Readings Taken with AC Set Tester, AC Line, 115 Volts

Tube		Filament Voltage	Plate Voltage	Grid Voltage	Screen Grid Voltage	Cathode Voltage	Plate Milliamperes
Type	Circuit						
24	1st R. F.	2.3	250	3.0	90.0	12	4.5
24	2d R. F.	2.3	250	3.0	90.0	11	4.5
24	Detector	2.3	35	1.0	2.0	8
27	1st Audio	2.3	120	1.0	8	3.0
71-A	{ 2d Audio } { Push-Pull }	5.0	215	50.0	18.0
71-A		5.0	215	50.0	18.0
80	Rectifier	5.0	36/Plate

All readings taken with antenna disconnected and ground on. Volume Control on full.

Table 2—Power Transformer Voltages

Terminals	A. C. Volts	
1-2	2.5	Heaters of 24 and 27 Tubes
3-4	105 to 125	Primary
7-8	5.0	Filament of 71-A Tubes
5	Center Tap of 7-8
10-11	5.0	Filament of 80 Tube
9-12	650	Plates of 80 Tube
6	Center Tap of 9-12 and 1-2

Table 4—Condenser Data
(Other Than Filter Condenser)

No. on Figs. 3 and 4	Capacity MFD
⑬	.00025
⑱	.01
⑥ ⑳	.05
⑧	.05 with 250-ohm resistor winding
⑭	.25 (two sections)
⑲	.5

Table 3—Resistor Data

No. on Figs. 3 and 4	Terminal	Resistance	Color		
⑳	{ 1-2 } { 2-3 } { 3-4 } { 5-6 } { 6-7 }	{ 1,400 } { 187 } { 75 } { 2,470 } { 975 }	Long Tubular		
				50,000	Orange
				100,000	Silver Gray
				250,000	White
				500,000	Battleship Gray
				⑫	
⑱					
⑮					
⑰-⑳					

Model 20—Filter Condenser—Part No. 4235

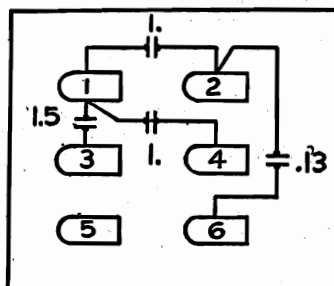

Model 20-A—Filter Condenser—Part No. 4269

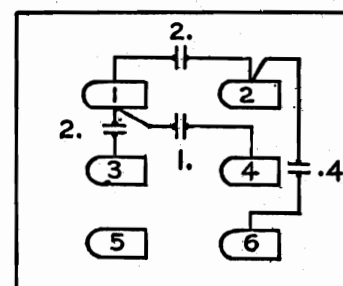

Models Philco's 20, 20A, 220, 220A

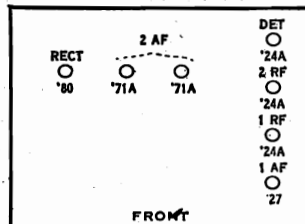

MODEL 20, 20-A

Chassis Schematic

PHILCO RADIO & TELEVISION CORP.

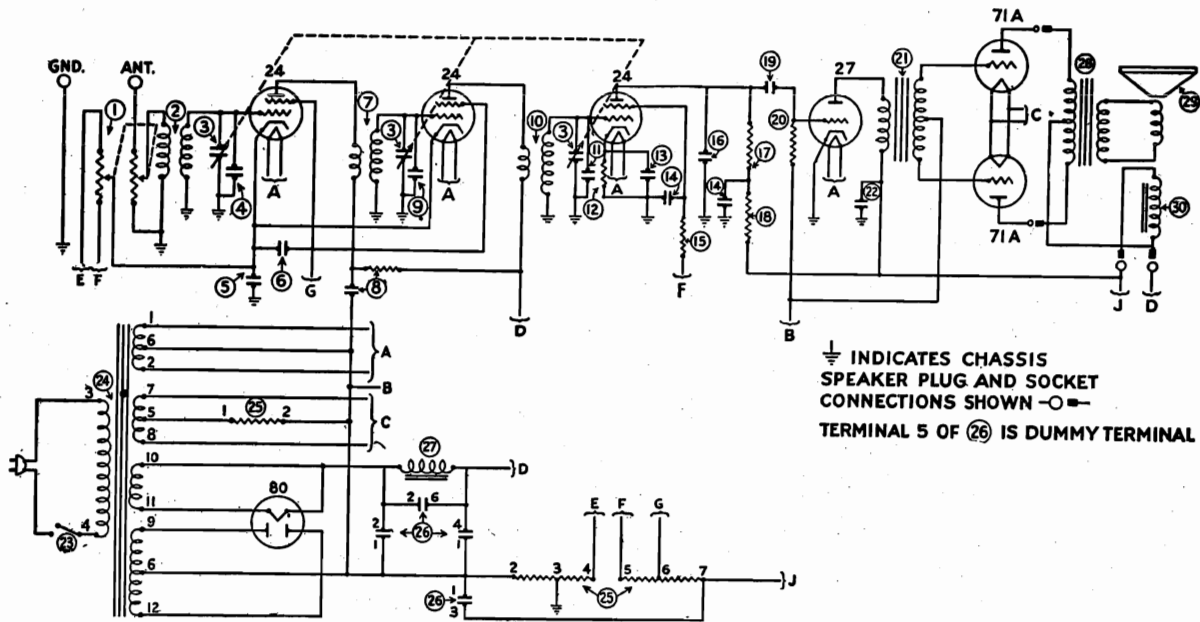

DIFFERENT CIRCUIT ARRANGEMENT FOR MODEL 20-A

Model 20-A for use on 25-60 cycle lines is wired differently than the Model 20. The plate supply lead for the two 24 R. F. Tubes is taken from the low side of the Speaker field Coil. The lead "D" to the 24 tubes should be changed to "J" for the Model 20-A only. This will change the plate voltage from 250 volts to 115-125 volts. The plate current readings will also be lower than those given in the table.

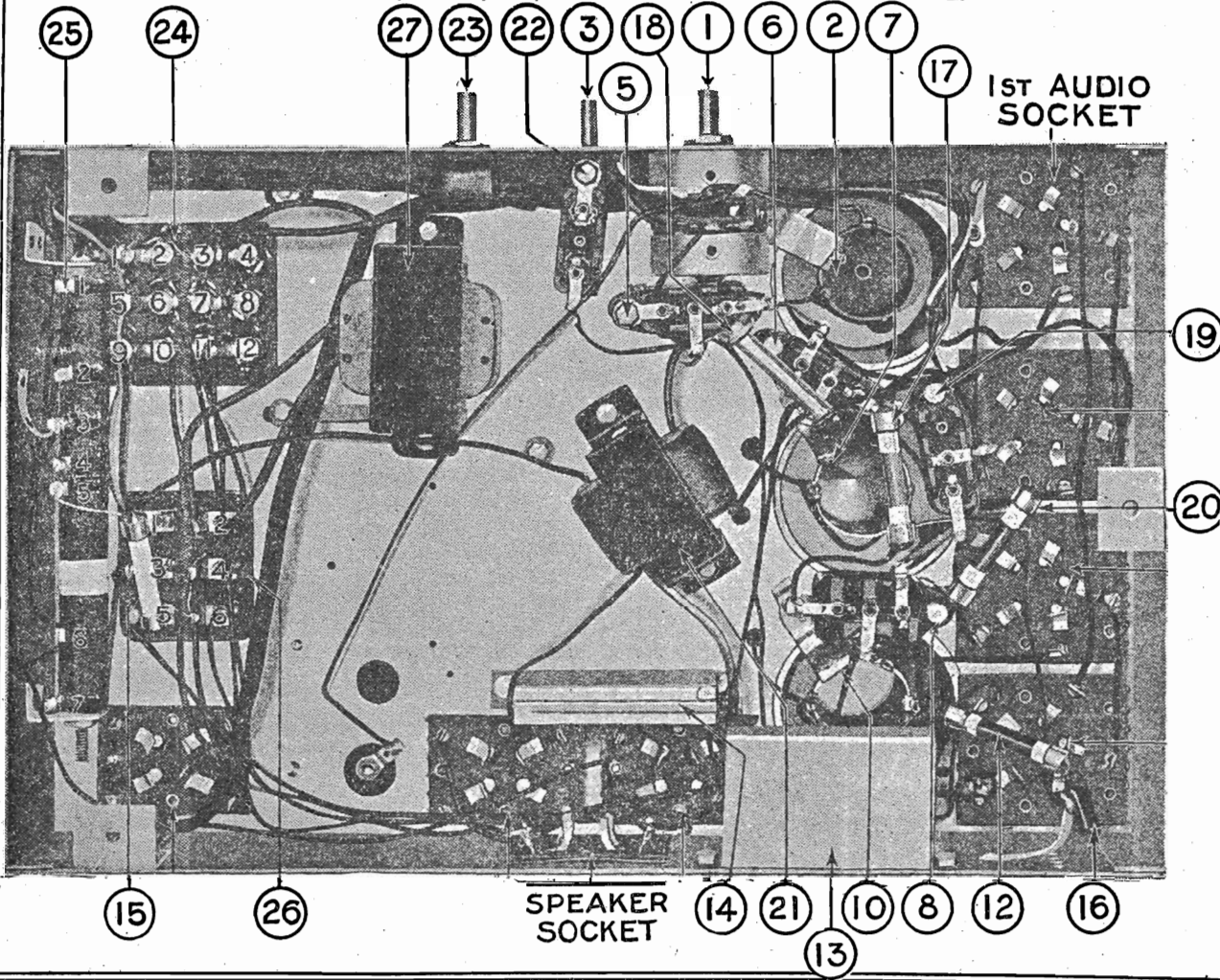

PHILCO RADIO & TELEVISION CORP.

MODEL 30
Voltage
Values

Table 1—Tube Socket Readings Taken with Average Set Checker

Tube	Circuit	Filament Volts	Plate Volts	Grid Volts	Plate Current Milliamperes	Screen Grid Volts
32	1st R. F.	2.0	150		.0015	60
32	2nd R. F.	2.0	150		.0015	58
32	3rd R. F.	2.0	150		.0015	58
30	Detector Rectifier	2.0
30	Detector Amplifier	2.0	15
30	1st Audio	2.0	90	Note 1	.002	..
31	{ 2d Audio }	2.0*	150	24	.008	..
31	{ Push-Pull }	2.0*	150	24	.008	..

*These readings reversed with respect to other Filament Voltage readings.

NOTE 1. With volume control in "Off" position, approximately 4 volts; with volume control full on, less than 1 volt.

Always use high-resistance voltmeter, preferably 1000 ohms per volt, when checking voltages in the Receiver. For reading plate and screen voltages, use a 250- or 300-volt scale. Voltage readings taken with meters having less than 250,000 ohms resistance will be lower than voltages given in the table.

When testing a Model 30 Receiver, all tubes must be in their proper sockets. The speaker must be connected and the tube shield must be fastened in place. The readings in Table 1 were taken using "A," "B" and "C" batteries.

Table 2—Resistor Data

No. on Figs. 1 and 2	Color	Resistance Ohms
①	Golden Yellow	5,000
④⑩	Auto Buff	25,000
⑥	Jade Green	70,000
②⑥ ②⑦	Silver Gray	100,000
②⑧	White	250,000
①⑨ ②⑨ ③②	Battleship Gray	500,000
③⑤	Tubular (two section)	{ 250 800

Table 3—Condenser Data

No. on Figs. 1 and 2	Capacity—MFD.
②④	.00005
③⑩ ③①	.000250
③③	.01
③ ⑨ ①⑤	.05
①① ①② ②⑩ ②①	.05 with 250-ohm resistor winding
③⑨	.25 single section
②②	.25 two sections

Either the ear method or an output meter can be used while adjusting.

With the Receiver set up for operation, adjust the oscillator signal to a frequency between 1200 and 1300 kilocycles. This corresponds to 120 and 130 on the Receiver tuning scale.

Use a weak signal and tune the Receiver sharply to the oscillator note. The volume control should be turned on "full."

Adjust the compensating condensers, starting with the fourth condenser ②④ in (Fig. 2.) If using the ear method, adjust the condenser to the loudest signal. If using an output meter, adjust for the maximum reading.

Next adjust the third, then the second, and finally the first. It will not be necessary to reduce the oscillator signal as the successive condensers are adjusted. Reduce the volume of the Receiver with the volume control.

In each step, always adjust for the maximum signal or reading.

PHILCO RADIO & TELEVISION CORP.

Numbering of Philco Coils

For the purpose of identification, Philco coils are being code numbered. These numbers are stamped upon the mounting bracket before the part leaves the National Service Station. The following is a list of these coils (Dated Jan. 1932)

KEY NO. IN SERVICE BULLETIN DIAGRAM

CODE NO.	PART NO.	USED IN MODELS	KEY NO. IN SERVICE BULLETIN DIAGRAM
1	3075A	511, 86, 87	①①①
2	3075B	511, 86, 87	②②②
3	3506B	65	③
4	3506A	65	④
5	3744A	95, 96	⑤⑤
6	3744B	95, 96	⑥⑥
7	3744C	95, 96	⑦⑦
8	03845	90 (Pentode Output)	⑧
9	3884A	76, 77, 40, 41	⑨⑨⑨⑨
10	3884B	76, 77, 40, 41	⑩⑩⑩⑩
11	3884C	76, 77, 40, 41	⑪⑪⑪⑪
12	3884N	20, 21	⑫
13	3884P	20, 21	⑬
14	3884S	111, 112	⑭
15	3884T	111, 112	⑮
16	3884U	111, 112	⑯
17	3884V	111, 112	⑰
18	3884X	46, 46E	⑱
19	3884Y	46, 46E	⑲
20	4182A	30	⑳
21	4182B	30	㉑
22	03014	90 (all Models)	㉒
23	03015	90 (all Models)	㉓
24	03016	90 (all Models)	㉔
25	03082	70, 35	㉕
26	03083	70, 35	㉖
27	03084	70	㉗
28	03283	50	㉘
29	03284	50	㉙
30	03320	35	㉚
31	03321	35	㉛
32	03360	90 (Pentode Output)	㉜
33	03013	90 (45's Output)	㉝
34	03009	90 (all Models), 35	㉞
35	03038	111, 112	㉟
36	03039	111, 112	㊱
37	03040	111, 112	㊲
38	03091	70	㊳
39	03092	70, 35	㊴
40	03143	90 (45's Output)	㊵
41	03734	4, 470, 490	㊶
42			㊷
43	03880	51	㊸
44	03881	51	㊹
45	03882	51	㊺
46	03887	51	㊻
47	03886	51	㊼

Coil Numbering Standard Compensating Condensers

The various compensating condensers used in the models 35, 70, 270, 370, 90, 112, and 212 have been changed so as to include a bakelite mounting board on which the code letter of the condenser appears. In the case of the I. F. compensating condensers, which have been used in conjunction with a parallel fixed condenser, the new compensating condensers have been increased in capacity so that the fixed condensers are no longer required. For replacement purposes, if desired, the new compensating condensers can be substituted on earlier sets for the earlier combination of a fixed and an adjustable condenser.

The low frequency compensating condensers have been changed with respect to the bakelite mounting, but their capacity remains unchanged, thereby requiring the parallel fixed condenser as in the past.

All of these new condensers can be identified by the letter which is stamped on the bakelite mounting board. For example part 04000-E has the letter E stamped over the surface of the mounting board; part 04000-F has the letter F stamped on the board.

The following table lists the part numbers of the various new condensers, their identification code letter, capacity range, where used, the superseded part number, and the part number of the parallel fixed condenser when one is still used.

(#98 - Dated Sept. 1931)

Part Number	Identification Letter	Capacity Range Mmf.	Used on Models	Supersedes	Used with Fixed Condenser
04000-B	B	40-250	90 (Early and Late)	03050	4520 (700 mmf.)
04000-D	D	6-50	112, 212	3772-A	—
04000-E	E	5-30	112, 212	3968-A	—
04000-F	F	40-250	112, 212 370 70, 270	3772-B	4520 (700 mmf.)
04000-H	H	40-180	35 70*, 270*, 370* 90* early	03120 03249	5120 (410 mmf.) 5120 (410 mmf.)
04000-J	J	40-180	70*, 270*, 370*, 212* 112*, 90* early	03051	—
04000-K	K	30-140	70*, 370*	3772-C	—
04000-L	L	30-140	270*	03061 03262	— —
04000-M	M	15-130	112* 35*	3772-D 03411	— —

*FIXED PARALLEL CONDENSER NOT REQUIRED

PHILCO RADIO & TELEVISION CORP.

MODEL 35
Test Data

All tubes out of sockets and batteries disconnected. Volume control maximum unless otherwise stated.

From Chassis To	Correct		Incorrect
Aerial	9.3	ohms	
RF Control Grid	251,000	ohms	BC- rf Cg wdg-Y (.09 mfd) TC- rf Cg-Y
RF Control Grid to IF Control Grid	72.5	ohms	TC- IF Tr
RF Screen Grid to 67 $\frac{1}{2}$ post.	150	ohms	
RF Screen Grid to Chassis	0	ohm	BC- rf Sg-Y BC- if Sg-Y (2 mfd)
RF Plate to 135 Post	16.4	ohms	
RF Plate to Chassis	0	ohm	BLC- Osc P circuit BC- IF P wdg-Y (.09 mfd) BC- D P-Y Tone Control Condenser BLC- D P - 1 AF Cg
1 Detector Control Grid	3,006.6	ohms	TC- 1 D Cg-Y BC- Osc Cplg wdg-Y BC- rf Cg wdg-Y
1 Detector Screen to 67 $\frac{1}{2}$ post	150	ohms	
1 Detector Screen Grid to Chassis	0	ohm	See RF Screen
1 Detector Plate to 135 Post	68	ohms	TC- IF Tr
1 Detector Plate to Chassis	0	ohms	See RF Plate
IF Control Grid	251,065	ohms	TC- IF Tr See RF Control Grid
IF Screen Grid to 67 $\frac{1}{2}$ post	150	ohms	
IF Screen Grid to Chassis	0	ohm	See RF Screen
IF Plate to 135 Post	74	ohms	TC- IF Tr
IF Plate to Chassis	0	ohm	See RF Plate
2 Detector Control Grid	25,000-100,000	ohms	Exact resistance of Cg voltage volume control not known BC- 2 D Cg wdg-Y
2 Detector Control Grid to -22 $\frac{1}{2}$ post	40,000-47,000	ohms	approximate
2 Detector Plate to 135 post	240,013	ohms	2 Detector plate chk is 13.4 ohms
2 Detector Plate to Chassis	0	ohm	See Rf Plate
1 AF Control Grid	493,000	ohms	
1 AF Plate to 67 $\frac{1}{2}$ Post	1,200	ohms	
'47 Control Grid to -22 $\frac{1}{2}$ Post	6,000	ohms	
'47 Screen Grid to 135 Post	0	ohm	
'47 Plate to 135 Post	450	ohms	
Output Transformer Secondary only	.62	ohm	
Oscillator Control Grid to Chassis	54,007	ohms	BC- Osc wdg-Y TC-Osc Cg-Y
Osc Cg to Osc Plate	0	ohm	BLC- Osc P
Oscillator Plate to 135	51,000	ohms	See RF Plate

MODEL 41 DC, 42 DC
Chassis
Changes

PHILCO RADIO & TELEVISION CORP.

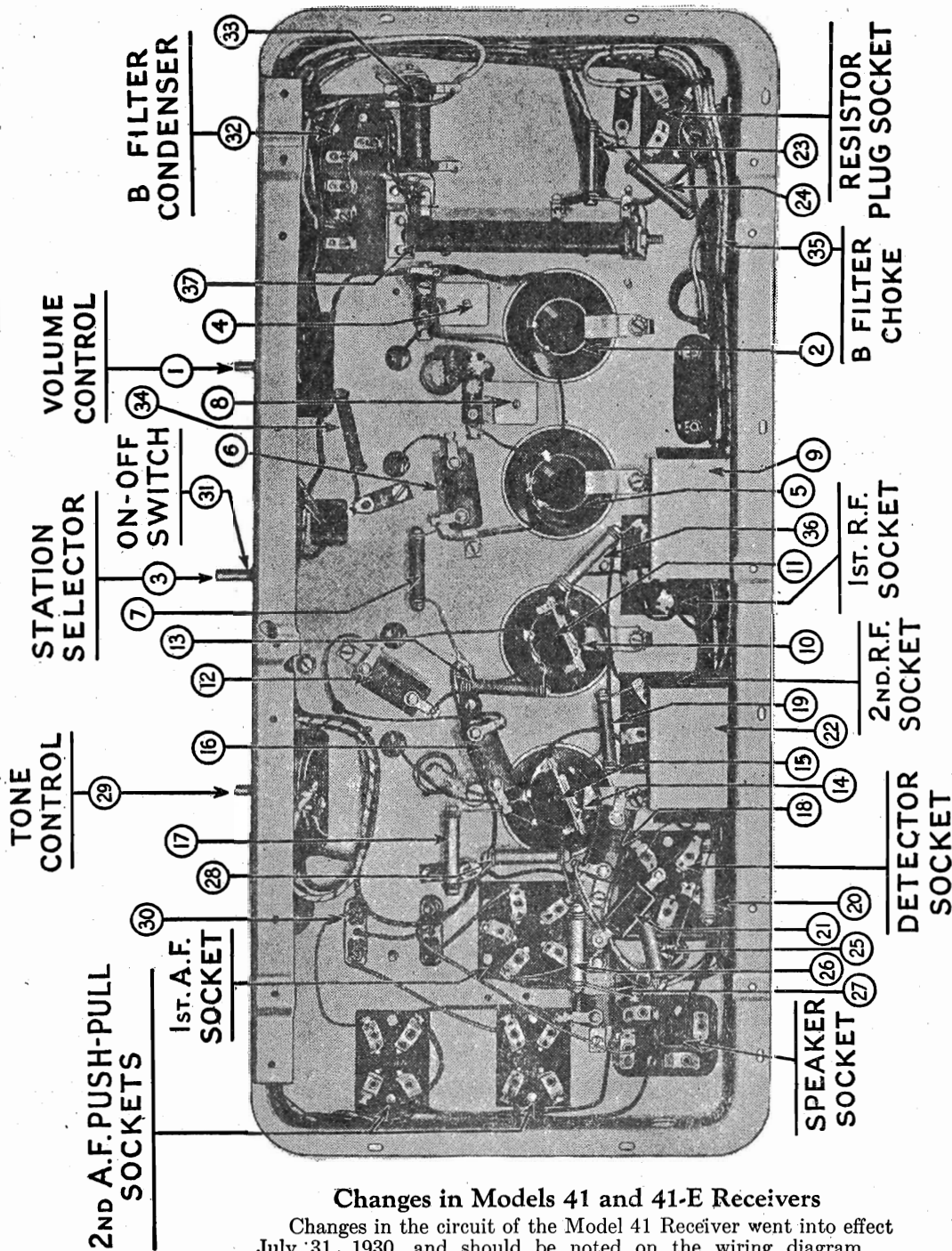

Changes in Models 41 and 41-E Receivers

Changes in the circuit of the Model 41 Receiver went into effect July 31, 1930, and should be noted on the wiring diagram

The R. F. by-pass condenser, Part No. 3615-G, or 3584-D, used to by-pass the plate supply of the R. F. tubes should be changed to Part No. 3615-B. In Service Bulletin 16 this condenser is shown as (18) and is connected between the lead "P" and condenser (9).

The new condenser No. 3615-B has the same capacity as the condenser formerly used, but in addition has a 250-ohm resistor section. One end of the condenser will be grounded through the hold-down screw of the condenser. The other terminal of the condenser is the terminal at the other end of the condenser. This terminal is also common to the resistor winding and should be connected to the point "P" shown on the schematic.

The middle terminal on the condenser is the other terminal of the resistor section, and should be connected to the R. F. coils (11) and (15).

With these changes made in the schematic, the plate supply for the first two "24" tubes will come from "P" through the resistor and then through the two R. F. transformers. The end of the resistor nearest "P" is by-passed through the condenser to ground.

PHILCO RADIO & TELEVISION CORP.

MODEL 50, 50-A
Adjustment
Parts List

ADJUSTMENT OF MODELS 50 AND 50-A

Adjustment of the compensating condensers in the model 50 should be done with the aid of a good oscillator for the R.F. signal. The oscillator lead should be connected to the "ANT" terminal of the receiver. A good ground connection must be made from the receiver to the grounded side of the oscillator and to a water or radiator pipe.

Either the ear method or an output meter, connected across the speaker voice coil terminals can be used while adjusting.

When the Receiver is set up for operation, adjust the oscillator signal to a frequency which is approximately 1400 kilocycles.

With the volume control advanced to maximum, and using a weak oscillator signal, tune the receiver sharply to the oscillator note.

Adjust the third R. F. compensating condenser by means of the Philco fibre wrench, part 3164, for maximum output signal. If an output meter is being used, adjust for maximum reading.

Next adjust the second R. F. compensating condenser and finally the first. In each case, always adjust for maximum signal or reading.

REPLACEMENT PARTS MODELS 50 AND 50-A

No. on Figs. 3 and 4	Description	Part No.	No. on Figs. 3 and 4	Description	Part No.
①	Volume Control	5232	②	Resistor—15,000 Ohms	5278
②	First R. F. Transformer	03283	③	Bypass Condenser—.05 Mfd.	3615-L
③	Gang Condenser	03293	④	Bypass Condenser—.05 Mfd.) (combined with ③)	
④	Compensating Condenser (Part of Gang Condenser Assembly)		⑤	Resistor—25,000 Ohms	3656
⑤	Second R. F. Transformer	03284	⑥	Resistor—99,000 Ohms	4411
⑥	Compensating Condenser (Part of Gang Condenser Assembly)		⑦	Resistor—32,000 Ohms	5279
⑦	Third R. F. Transformer	03284	⑧	Resistor—99,000 Ohms	4411
⑧	Compensating Condenser (Part of Gang Condenser Assembly)		⑨	On-Off Switch	5382
⑨	Condenser—250 Mmf.	3082	⑩	Power Transformer—50-60 cycles Power Transformer—25-40 cycles	5266 5267
⑩	Condenser—250 Mmf.	3082		Power Transformer—50-60 cycles 210-240 volts	5268
⑪	Resistor—10,000 Ohms	4412	⑪	Electrolytic Condenser—6 Mfd.— 50-60 cycles	4916
⑫	Condenser—.01 Mfd.	3903-L	⑫	Electrolytic Condenser—10 Mfd. 25-40 cycles	5142
⑬	Resistor—240,000 Ohms	4410	⑬	Electrolytic Condenser—6 Mfd.— 25-40 cycles and 50-60 cycles	4916
⑭	Resistor—490,000 Ohms	4517		Tube Shield	03390
⑮	Bypass Condenser (.15 Mfd., .25 Mfd., 2-.5 Mfd., 1 Mfd.) 50-60 cycles	03459		Knob (Large)	03064
	(.15 Mfd., .25 Mfd., 2-.5 Mfd., .05 Mfd.) 25-40 Cycles	03455		Knob (Small)	03427
⑯	Bypass Condenser—.01 Mfd.	3903-N		Spring (For Dial Knobs) Small	4147
⑰	Output Transformer	2660		Spring (For Dial Knobs) Large	5262
⑱	Voice Coil and Cone Assembly	02970		Grid Clip	4897
⑲	Speaker Field (Assembled with Pot and Frame)	02942		Five Prong Socket Assembly	4956
⑳	Resistor—490,000 Ohms.	4517		Four Prong Socket Assembly	5026
㉑	Resistor—160,000 Ohms.	5331		Dial Complete	03322
㉒	Resistor—150 Ohms and Con- denser—.05 Mfd.	3615-X		Bezel	5383

MODEL 50,50-A
Resistance
Test Data

PHILCO RADIO & TELEVISION CORP.

All tubes cut of sockets and AC plug disconnected from power supply
Field Coil disconnected

From Chassis To	Correct	Incorrect
Aerial (V.C. Max)	24 ohms	Aerial V.C. 1800 ohms
1 RF Control Grid	6.5 ohms	TC- rf Cg-Y
1 RF Cathode (V.C.Max)	150 ohms	BC- rf K-Y (.05 mfd)
1 RF Screen Grid	20,150 ohms	V.C. in circuit 5000 ohms See RF Cathode BC- 2 rf Sg-Y FC- 80 F-Y (6 mfd EL)
1 RF Screen Grid to 80 Fil	25,000 ohms	
1 RF Plate	45,215 ohms	BC- rf P-Y See RF Screen
1 RF Plate to '80 Fil	65 ohms	
2 RF Control Grid	6.5 ohms	TC- 2 rf Cg-Y
2 RF Cathode(V.C.Max)	150 ohms	See 1 RF Cathode
2 RF Screen Grid	20,150 ohms	See 1 RF Screen
2 RF Screen Grid to '80 Fil	25,000 ohms	
2 RF Plate	45,215 ohms	See 1 RF Plate
2 RF Plate to 80 Fil	65 ohms	
Detector Control Grid	6.5 ohms	TC- D Cg-Y
Detector Cathode	32,000 ohms	BC- D K-Y
Detector Screen Grid	119,150 ohms	BC- D Sg-Y See RF Screen
Detector Screen Grid to 80 Fil	124,000 ohms	
Detector Plate	394,150 ohms	BC- 99,000 ohms-Y BLC- D P -47 Cg BC- D P-Y FC- 80 Fil-80 P wdg See RF Screen
Detector Plate to '80 Fil	349,000 ohms	
'47 Control Grid	650,000 ohms	BC- 47 Cg leak-Y
'47 Screen Grid to '80 Fil	0 ohm	
'47 Screen Grid to Chassis	45,150 ohms	See RF Screen
'47 Plate	45,516 ohms	See RF Screen
'47 Plate to '80 Fil	366 ohms	
'80 Fil to 80 Plate	695,460 ohms	FC- 80 F-(10 mfd EL)
'80 Plate to Chassis	650,310 ohms	
'80 Plate to 80 Plate	621 ohms	
Across AC plug	7.55 ohms	

A resistor of 10,000 ohms is used in place of an r-f choke in the detector plate circuit. Two bypass condensers, with mid-junction grounded are connected across the resistor.

A fixed condenser is connected between the plate of the pentode tube and ground.

PHILCO RADIO & TELEVISION CORP.

MODEL 51, 51-A
Schematic

ARRANGEMENT OF WIRES

The placing of certain wires in the receiver will effect the operation to a marked extent. The red wire from the primary of the first I. F. transformer (3), Figs. 1 and 2, to the .05 mfd. condenser (9), Figs. 1 and 2, must come straight down to the corner of the I. F. tube socket, then straight up to the condenser lug.
The wire from the plate of the detector-oscillator tube to the coupling compensating condenser (7), Figs. 1 and 2, must be away from the chassis at the side.

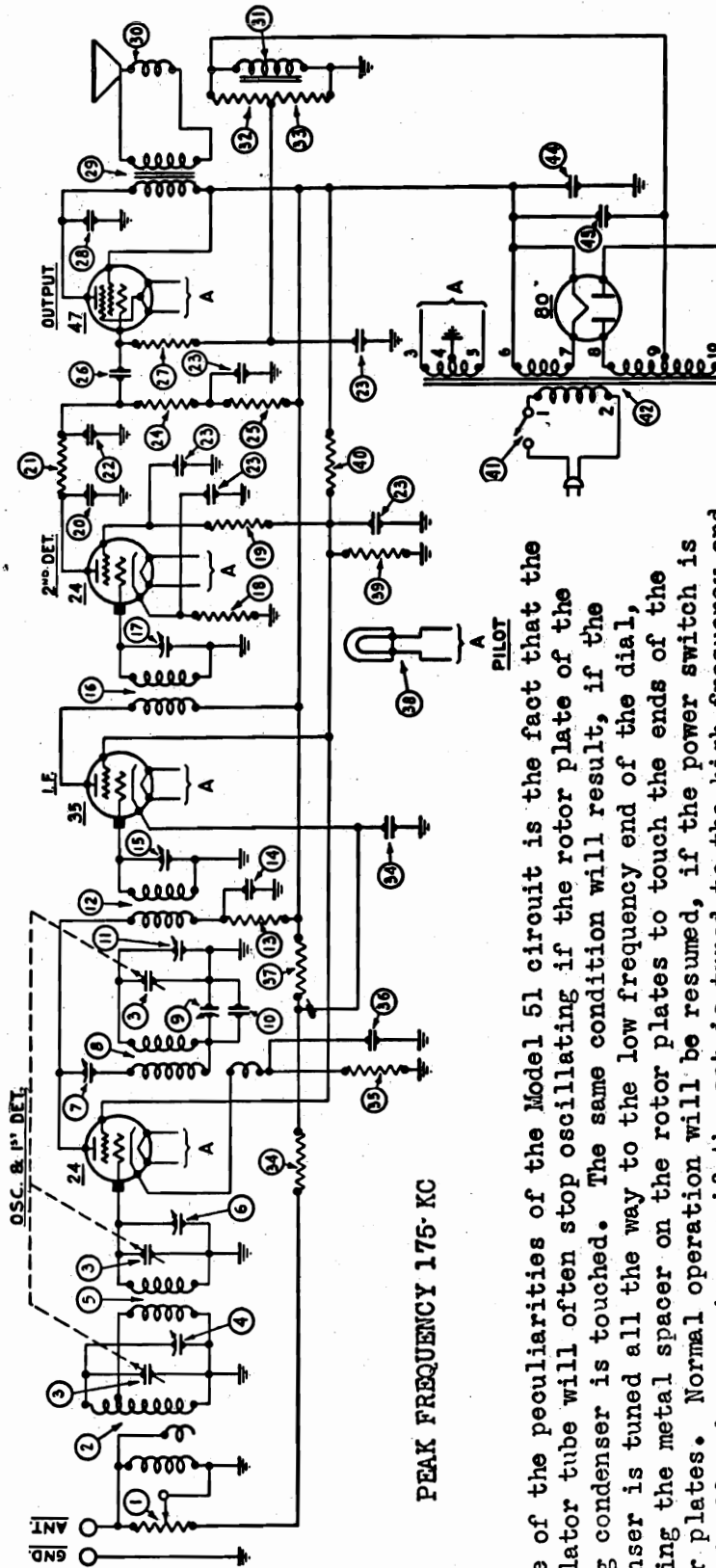

PEAK FREQUENCY 175 KC

One of the peculiarities of the Model 51 circuit is the fact that the oscillator tube will often stop oscillating if the rotor plate of the tuning condenser is touched. The same condition will result, if the condenser is tuned all the way to the low frequency end of the dial, allowing the metal spacer on the rotor plates to touch the ends of the stator plates. Normal operation will be resumed, if the power switch is snapped off and on again, or if the set is tuned to the high frequency end of the dial. An insulated wire is placed around the metal spacer on one set of rotor plates to prevent them from touching the stator. Later model 51s have a small fibre insulator of special design to replace the wire.

The coupling condenser and the two i-f trimmer condensers are located at the rear of the chassis, near the combination 1st detector-oscillator tube. Reading from left to right, facing the rear of the chassis, the condensers are "coupling", "2nd i-f" and "1st i-f".

Models 51, 52, 51A, 551 (1932)

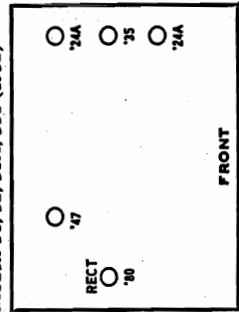

MODEL 51, 51-A
Voltage
Electrical
Data

PHILCO RADIO & TELEVISION CORP.

Model 51 Receivers are for operation on 100-130 volt, 50-60 cycle AC line
Model 51-A Receivers are for operation on 100-130 volt, 25-40 cycle AC line

Table 1—Tube Socket Readings Taken with AC Set Tester AC Line—115 volts

Tube		Filament Volts	Plate Volts	Screen Grid Volts	Control Grid Volts	Cathode Volts	Plate Milli- amperes
Type	Circuit						
24	Osc. & 1st Det.	2.2	220*	85*	9.0*	9.0*	
35	I.F.	2.2	210	85	3.0	3.0	6.2
24	2nd Det.	2.2	75	54	5.2	5.2	0
47	Output	2.2	210**	240**	0.2**		28.**
80	Rect.	5.0	240/Plate				30/ Plate

Note—Volume Control on full, Station Selector turned to Low Frequency End.

*These readings must be taken from the underside of the chassis, using a suitable high resistance D.C. voltmeter equipped with test prods and leads.

**These readings must likewise be taken from the underside of the chassis unless the set tester is especially equipped for testing pentode tubes.

Table 2—Power Transformer Voltages

Terminals	A.C. Volts	Connection	Color
1-2	105 to 125	Primary	Black (Small Gauge)
3-5	2.5	Filament of 24, 35 and 47	Black
6-7	5.	Filament of 80	Light Blue
8-10	700.	Plates of 80	Yellow
4	...	Center Tap of 3-5	Black, Yellow Tracer
9	Center Tap of 8-10	Yellow, Green Tracer

Table 3—Condenser Data

Nos. on Figs. 1 and 2	Capacity Mfd.	Container
(20) (22)	.00025	Yellow
(10) (36)	.00011	Blue and Golden Yellow
(26) (28)	.01	Black Bakelite Container
(14)	.05	Black Bakelite Container
(23)	.1, .15, .25, 2-5 (50-60 cy.)	Metal Container
(43)	.2, .15, .25, 2-5 (25-40 cy.)	Metal Container
(44)	6 (50-60 cycles)	Electrolytic
	10 (25-40 cycles)	Electrolytic
	6	Electrolytic

Table 4—Resistor Data

Nos. on Figs. 1 and 2	Power (Watts)	Resistance (Ohms)	Color		
			Body	Tip	Dot
(34)		250 and .05 Mfd.		Black Bakelite Container	
(13)	.5	1,000	Brown	Black	Red
(35)	.5	8,000	Grey	Black	Red
(21)	.5	10,000	Brown	Black	Orange
(39)	1.	25,000	Red	Green	Orange
(16)	.5	32,000	Orange	Red	Orange
(40)	1.	32,000	Orange	Red	Orange
(37)	2.	51,000	Green	Brown	Orange
(19) (25)	.5	99,000	White	White	Orange
(33)	.5	160,000	Brown	Blue	Yellow
(24) (27) (32)	.5	490,000	Yellow	White	Yellow

Standard Bypass
Condenser Data

PHILCO RADIO & TELEVISION CORP.

Standard By-Pass Condenser Data

The tables below list the various Philco standard by-pass condensers in black bakelite containers. The drawing shows all possible lug connections and the tables list the lug numbers.

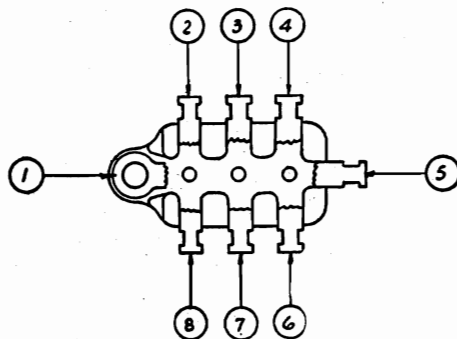

Condenser 3615 .05 Mfd.

Part No.	Cond. Cap. Mfd.	Lugs Used	Wire Resis. Ohms	Resis. Wiring Lugs	Cond. Wiring Lugs
3615-B	.05	1-3-5	250	3-5	1-5
3615-C	.05	1-5-7	250	5-7	1-5
3615-D	.05	1-3-5	1-5
3615-E	.05	2-5
3615-F	.05	2-3-5	3-5
3615-G	.05	5-8
3615-H	.05	3-5-8	5-8
3615-J	.05	1-5-7	1-5
3615-K	.05	3-5-8	250	3-5	5-8
3615-L	.05	1-5
3615-M	.05	2-5-7	2-5
3615-N	.05	1-4-7	1-4
3615-P	.05	1-4-7	250	4-7	1-4
3615-R	.05	1-5-7	250	5-7	1-5
3615-S	.05	1-4
3615-T	.05	1-5-7	150	1-7	1-5
3615-U	.05	1-5-7	1-7
3615-W	.05	1-2-5	1-5
3615-X	.05	1-2-5-7	150	1-7	1-5
3615-Y	.05	1-2-5-7	150	1-5	1-7

Condenser 3793 .015 Mfd.

Part No.	Cond. Cap. Mfd.	Lugs Used	Wire Resis. Ohms	Resis. Wiring Lugs	Cond. Wiring Lugs
3793-B	.015	5-7
3793-C	.015	2-4
3793-D	.015	2-6
3793-E	Twin .015	1-5-7	1-5 & 1-7
3793-F	.015	5-7-8	7-8
3793-G	.015	2-3-6	2-6
3793-H	Twin .015	1-3-5	1-3 & 1-5

Condenser 3903 .01 Mfd.

Part No.	Cond. Cap. Mfd.	Lugs Used	Wire Resis. Ohms	Resis. Wiring Lugs	Cond. Wiring Lugs
3903-F	.01	3-5
3903-G	.01	2-4-7	2-4
3903-H	.01	5-8
3903-J	.01	2-5-7	2-5
3903-K	.01	1-2-4-7	1-7
3903-L	.01	3-5-8	3-5
3903-M	.01	4-7-8	4-8
3903-N	.01	3-5-8	5-8
3903-P	.01	2-5-7	2-7

Condenser 4989 .09 Mfd.

Part No.	Cond. Cap. Mfd.	Lugs Used	Wire Resis. Ohms	Resis. Wiring Lugs	Cond. Wiring Lugs
4989-B	Twin .09	1-3-5	1-3 & 1-5
4989-C	Twin .09	1-5-7	1-5 & 1-7
4989-D	.09	1-5
4989-E	.09	1-5-7	250	7-5	1-5
4989-F	.09	1-5-7	1-5
4989-G	Twin .09	1-4-7	1-4 & 1-7
4989-H	Twin .09	1-5	1-5 & 1-5

PHILCO RADIO & TELEVISION CORP.

REPLACEMENT PARTS—MODELS 70 AND 70-A
(Service Bulletin No. 57)

No. on Figs. 3 and 4	Description	Part No.	No. on Figs. 3 and 4	Description	Part No.
①	Volume Control	5039	⑩	Condenser (Electrolytic) (50-60 cycles)	4916
②	First R. F. Transformer	03082		Condenser (Electrolytic) (25-40 cycles)	5142
③	Tuning Condenser (25-40 cycles)	03077	⑪	Filter Choke	4951
	Tuning Condenser (50-60 cycles)	03076	⑫	Condenser (Electrolytic) (50-60 cycles)	4916
④	Compensating Condenser (Part of Gang Assembly)			Condenser (Electrolytic) (25-40 cycles)	5142
⑤	Bypass Condenser—.09 M. F. Double	4989-C	⑬	Pilot Lamp	3463
⑥	First Detector Transformer	03083	⑭	Power Transformer—50-60 cycles	5117
⑦	Compensating Condenser (Part of Gang Assembly)			Power Transformer—25-40 cycles	5118
⑧	Oscillator Coil	03084	⑮	Switch	4095
⑨	Fixed Condenser—.00041 M. F.	5120	⑯	Bypass Condenser—.015 M. F. (Double)	3793-H
⑩	Compensating Condenser	03120	⑰	Tone Control	03140
⑪	Resistor—50,000 Ohms	4237		Mica (Compensating Condenser)	3473
⑫	Bypass Condenser—.09 M. F. Double	4989-C		Insulating Washer (Compensating Condenser)	3500
⑬	Compensating Condenser (Part of Gang Assembly)			Rubber Washer (Chassis Mtg.)	5189
⑭	Resistor—5,000 Ohms	3526		Grommet (R. F. Transformer Shield)	3747
⑮	Condenser—.00011 M. F.	4519		Rubber Washer (Tuning Condenser Mtg.)	3914
⑯	Resistor—13,000 Ohms	3766		Rubber Washer (Tuning Condenser Mtg.)	3915
⑰	Condenser—.00011 M. F. }	3772-C		Rubber Washer (Tuning Condenser Mtg.)	3916
⑱	Compensating Condenser }			Spring Switch Knobs	4147
⑲	First I. F. Transformer	03091		Grid Clip	4897
⑳	Compensating Condenser }	03051		Five Prong Socket	4956
㉑	Fixed Condenser—.00011 }			Speaker Socket	4957
㉒	Second I. F. Transformer	03092		Knobs (Dial)	03063
㉓	Bypass Condenser—.05 M. F.	3615-L		Tube Socket (Rectifier Tube)	5026
㉔	Compensating Condenser }	03061		Steel Washer (Chassis Mtg.)	5058
㉕	Condenser—.00005 }			Knob (Switch, Tone, Volume) (Baby Grand)	4290-A
㉖	Bypass Condenser—.5	3583		Volume Control Insulator	4092
㉗	Resistor—50,000 Ohms	4237		Volume Control Insulator	4286
㉘	Condenser—.0005	3910		Knob—Tone, Volume (Highboy)	03064
㉙	Condenser—.00025	3082		Nut—Volume, Tone, Switch	W-434
㉚	Detector R. F. Choke	03086		Complete Drive Bracket	03011
㉛	Resistor—250 Ohms and Condenser—.09 M. F.	4989-E		Dial Disc Assembly	03031
㉜	Resistor—250,000 Ohms	4410		Fahnestock Clip	L-1126
㉝	Resistor—100,000 Ohms	4411		Knob Spring - Tone, Volume, Dial for Lowboy and Highboy	5262
㉞	Condenser—.01 M. F.	3903-J		Knob Spring - Tone, Volume for Baby Grand	5173
㉟	Resistor—250,000 Ohms	4410		Knob Spring - Dial - Baby Grand	5262
㊱	Condenser—.25 M. F.	4264			
㊲	Output Transformer	2873			
㊳	Voice Coil and Cone	02996			
㊴	Speaker Field assembled with Pot and Frame	02966			
㊵	B. C. Resistor	5125			

Several changes in wiring and part numbers have been made in model 70. The filter choke, part 4951 has been changed to part 4819, the same choke as used in the model 21. On the 50-60 cycle models, a .09 mfd. condenser, part 4989-J, is connected across the filter choke, part 4819. On the 25 cycle models, this condenser should be .18 mfd., part 4989-H, ungrounded. The two 240,000 ohm resistors, part 4410, Nos. 32 and 35 Service Bulletin No. 57 and Nos. 25 and 29, Service Bulletin No. 85, should be of the Continental Carbon type. This is the resistor without the metal ends.

MODEL 70, 70-A
Above B-22,000
Chassis

PHILCO RADIO & TELEVISION CORP.

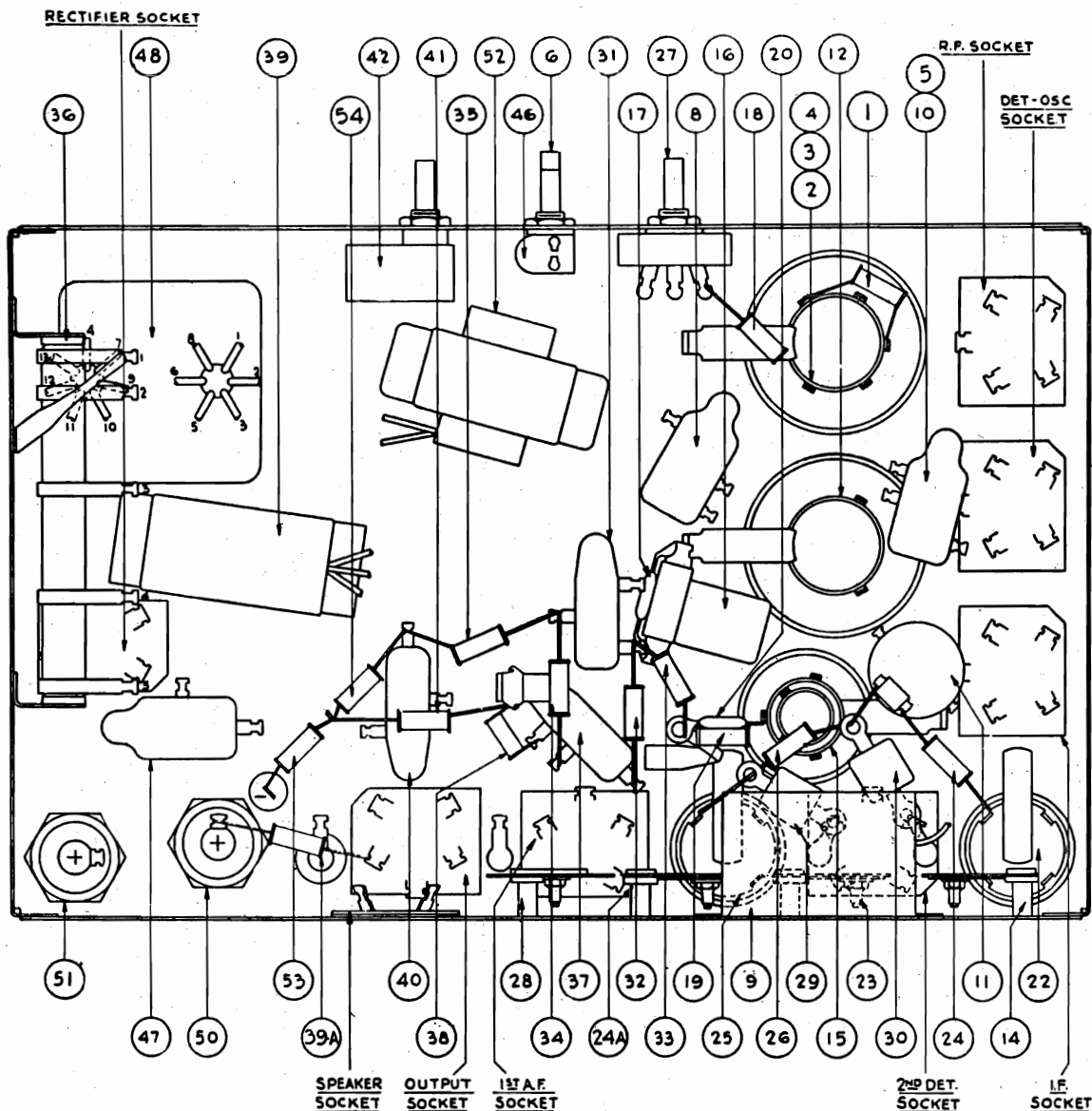

MODELS 70 AND 70-A

Above Serial B-22000

Part Numbers on Service Reports

It is highly important that the complete part number including the letter, of defective parts be specified on all of your service reports. Many parts have a letter after the part number as listed in the service bulletins. Other parts—namely, power transformers, audio transformers, filter chokes, field coils, electrolytic condensers, and volume controls are listed in the service bulletins without a letter, but actually have this letter stamped on the part itself after the part number.

Adjusting Superheterodynes

PHILCO RADIO & TELEVISION CORP.

Adjusting Philco Superheterodynes

The compensating condensers in every Philco Receiver are carefully adjusted before the set leaves the factory. Under ordinary circumstances they should never have to be re-adjusted in the field. Extremely rough handling during shipment, or a slight change in some of the electrical characteristics of the radio circuit may in some cases make re-adjustment necessary.

The indications that the set may require re-adjustment are poor sensitivity, poor selectivity and dial readings in kilocycles of more than 20 K. C. In some cases, an unstable condition of the set with a tendency to squeal or howl on certain sections of the dial may also be an indication of improper adjustment.

Under no circumstances should a re-adjustment be attempted unless the necessary equipment is available and unless the proper instruction has been received. Your distributor will gladly assist you in both of these matters.

The general method of adjusting the compensating condensers in all Philco superheterodyne receivers is the same. Once this procedure is understood for one model, it can be applied with but little change to the various other Philco models. By means of the instructions below and by reference to the different illustrations, the complete adjustments can be made on all Philco superheterodynes.

EQUIPMENT. The following equipment is needed:
 Intermediate frequency oscillator accurately calibrated at 175 K. C. and 260 K. C. The Philco Oscillator Model 095 is recommended.

1. Output meter. The oscillator mentioned above is equipped with an output meter.
2. Philco fibre wrench, part 3164.
3. INTERMEDIATE FREQUENCY OR I. F. ADJUSTMENTS. The adjustment of the I. F. compensating condensers should be done in the following manner:

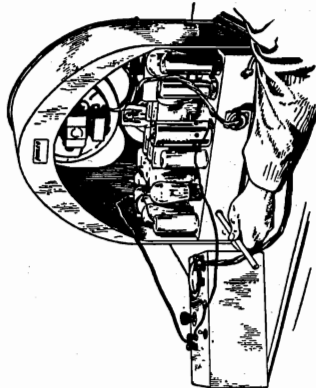

Fig. 1

1. Make the necessary connections between the oscillator and the receiver as shown in the illustration, Fig. 1. The connections consist of (a) the ground wire to the GND terminal of the radio set and to the G terminal of the oscillator; (b) the A terminal of the oscillator to the grid of the first detector tube (tube shield in place and first detector grid clip removed), (c) output meter terminals to the primary of the output transformer (this connection is obtained at the speaker plug and socket through the Philco plug-in adapter, part 6095), (d) power cord of receiver to the electric power outlet after all other connections have been completed.
2. Turn on the radio set and the oscillator. For Philco models of the 70 and 35 series, the oscillator switch should be placed in the 260 K. C. position. For models of the 111, 112, 90 and 51 series, the switch should be placed in the NORMAL-MAXIMUM position. Turn the radio volume control to Maximum until a reading is obtained on the output meter of approximately 1/2 the scale deflection. By means of the Philco fibre wrench, part 3164, adjust the various intermediate frequency compensating condensers, one at a time, to obtain maximum reading in the output meter. Locations of all compensating condensers are shown in the illustrations on pages 3 and 4. It is desirable to start with the last I. F. compensating condenser in the circuit (2nd I. F. secondary in the case of the 112) and progress in the adjustments toward the first. It may be necessary while the adjustments are being made, to lower the setting of the oscillator control from time to time so as to keep the output meter reading within the scale range.
3. After these adjustments have been completed, remove the oscillator connection from the grid terminal of the first detector tube and restore the grid clip connection to this terminal.
4. **COUPLING CONDENSER.** Adjust the coupling condenser in the Model 51 at 175 K. C. in the same manner as the I. F. condenser

HIGH FREQUENCY ADJUSTMENTS. Improper adjustment of the high frequency compensating condenser is characterized by weak reception and poor selectivity at the high frequency end of the dial and by dial readings being off by more than 20 K. C. at this end of the dial. Proceed in the following manner:

1. Connect from the A terminal of the oscillator to the ANT terminal of the broadcast receiver. All other connections remain the same as for adjustment of the I. F. compensating condensers. See Fig. 2 for complete connections.
2. Set the switch on the oscillator to 175 K. C. Set the dial of the receiver to exactly 140 (1400 K. C.). The eighth harmonic of 175 K. C. will be received at this point. Turn the volume control to maximum. Turn on the oscillator and adjust the control until a 1/2 scale reading is obtained on the output meter. If the receiver is badly out of adjustment, it may not be possible to obtain such a reading, in which case the meter reading must be disregarded temporarily and the adjustments made by ear.
3. Carefully adjust the high frequency compensating condenser for maximum reading in the output meter or for maximum volume if the output is not great enough to be read on the meter.

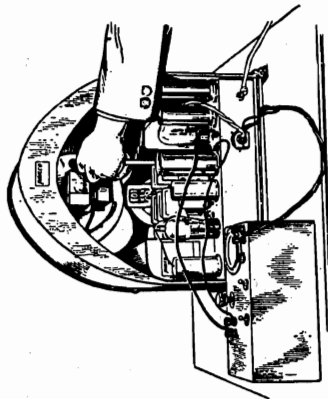

Fig. 2

4. When making this adjustment, it may be found that a given position of the adjusting nut can be obtained at which maximum reading is noted, but that the meter reading decreases when the fibre wrench is lifted from the nut. Allow for this condition by turning slightly beyond the point of maximum reading, then when the wrench is removed the reading will go up instead of down.
5. After making the adjustment, turn the station selector slightly to note if any increase in volume is obtained as the set is being re-tuned. If such an increase is obtained, then the antenna, detector and r. f. condensers should be re-adjusted as described below. After this adjustment, the high frequency condenser can again be re-adjusted at 1400 K. C.
6. In some cases, when first starting to make the 1400 K. C. adjustment, it may be found that the signal from the oscillator cannot be heard at 140 because the set is so far out of adjustment. In this case, tune the set to the signal, and then adjust the Antenna Detector and R. F. condenser first. Re-adjust the high frequency condenser at 140 on the dial.

ANTENNA, DETECTOR, AND R. F. ADJUSTMENTS:
 The adjustment of the antenna, detector, and R. F. compensating condensers is done at 140 on the dial in the same manner and with the same connections as for the high frequency adjustments.

LOW FREQUENCY ADJUSTMENT. The characteristics of improper adjustment of the low frequency compensating condensers are weak reception, poor selectivity and dial calibrations off more than 20 K. C. at the low end of the dial. The low frequency adjustment is made with the same connections as for the high frequency and Antenna condenser adjustments. Proceed in the following manner:

1. With the receiver and the oscillator in operation, the latter at 175 K. C., set the Philco dial at exactly 70 on the scale.
2. With the volume control at maximum, adjust the oscillator output until the output meter reads approximately 1/2 scale deflection. Adjust the low frequency compensating condenser for maximum reading in the output meter.
3. If the signal comes in stronger at a position off 70 on the Philco scale, adjust for maximum output on the meter at this "Off K. C." position of the dial. Now re-tune the set slightly to obtain any further possible increase, adjusting the compensating condenser and re-tuning the dial each time so as to bring the point of maximum output as near 70 as possible.
4. Re-set the dial to exactly 140, and re-adjust the high frequency condenser. It is possible that the adjustment of the low frequency condenser has affected the high setting of the dial slightly.

MODEL 65

PHILCO RADIO & TELEVISION CORP.

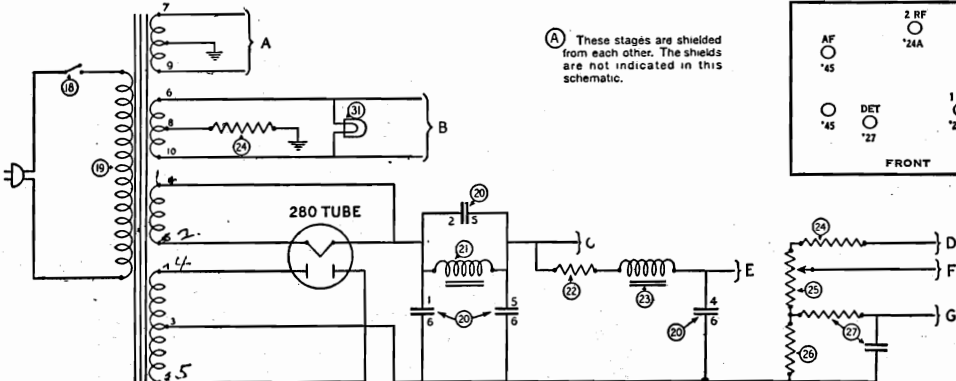
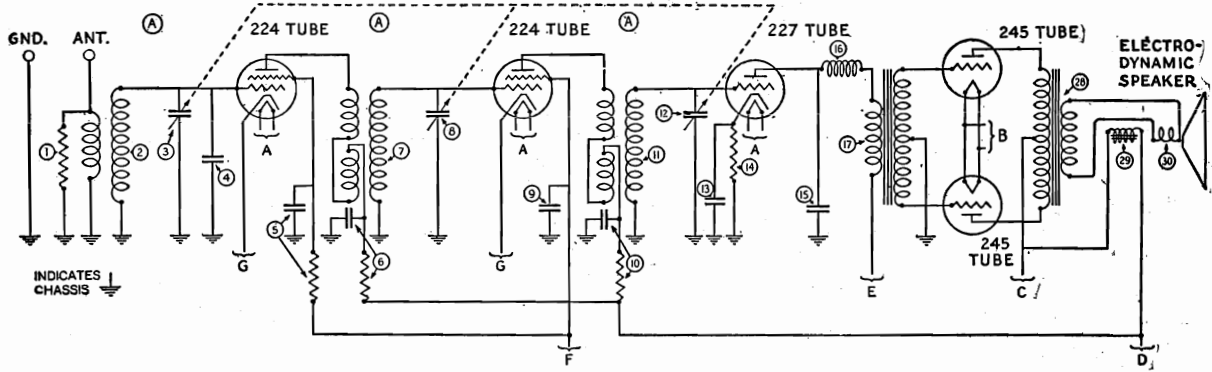

Table 8
Tube Socket Readings

TYPE TUBE	"A" VOLTS	"B" VOLTS	"B" VOLTS (SCREEN GRID)	"C" VOLTS (CONTROL GRID)	MA PLATE	CATHODE
224	2.5	150	*.2 to .75	1.5	1.5	+1.5
227	2.5	250	...	28	†.8 to 3.5	+28
245	2.5	250	...	50	32	...
280	5.0	350-V. A.C.	55	...

*The voltage varies from 75 volts with the volume control turned for full volume to .2 volts with the control turned for minimum volume.
 †When there is no signal being reproduced the detector plate current will be about .8 MA. Strong signals will cause a rise in current to 3.5 MA.

Table 9
Power Transformer Voltage [AC]

TERMINALS	A.C. VOLTS	SECONDARY
1-2	700	A.C. Supply to Plates of Rectifier Tube
3		Center Tap of Rectifier Plate Secondary
4-5	5.0	Rectifier Filament
6-10	2.5	Filament 245 Tubes
8		Center Tap of 245 Tube Secondary
7-9	2.5	Heater 224 and 227 Tubes

Green lead - Center Tap for Secondary 7-9
 Current Consumption - 125 V. A.C. 95 Watts

Table 10
D. C. Voltage Across Filter Condenser Block

TERMINALS	D.C. VOLTS	CAPACITY	CIRCUIT
1-6	325	2.0 Mfd.	First Filter Section, Ground to 280 Filament
2-5	20	.15 Mfd.	Parallel with First Choke Coil
3	Blank Terminal for Detector Plate Resistor
4-6	280	1.0 Mfd.	Last Filter Section, Gnd. to Det. Plate Lead
5-6	305	2.0 Mfd.	2d Filter Section, Gnd. to End of First Choke

Table 11
Voltage Across Resistors

RESISTOR NUMBER	RESISTOR TERMINAL	VOLTAGE DROP	CIRCUIT
①	1-2	45-50	Grid Bias for the 245 Tubes
②	3-4	75-80	Reduces B Voltage for the Screen Grid
③	1-2	4-10	Detector Plate Voltage
④	1-2	28	Detector Grid Bias
Field Coil of Speaker		135-140	Supplies Field Energy of Dynamic Speaker

PHILCO RADIO & TELEVISION CORP.

MODEL 76

Philco Model 76

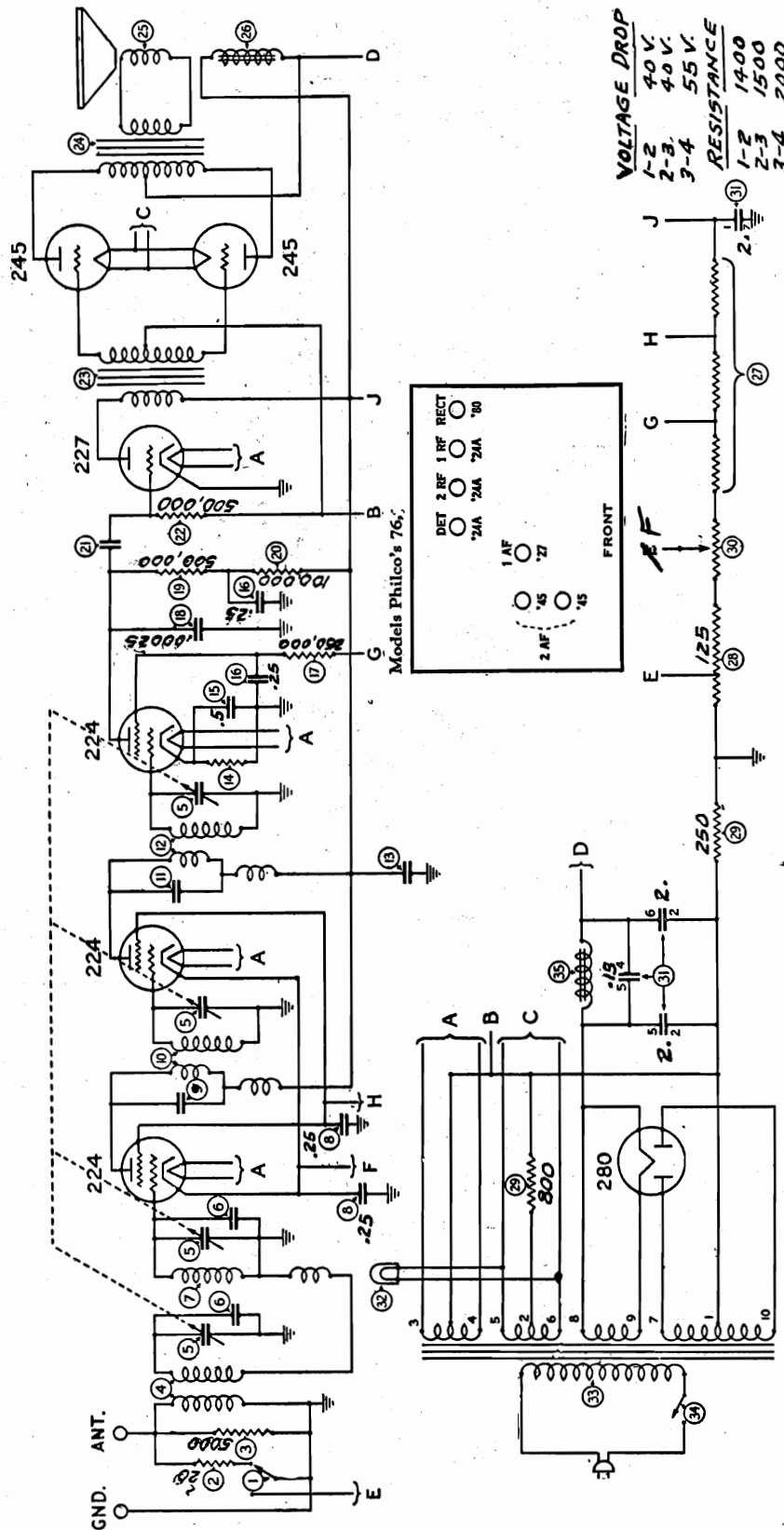

VOLTAGE DROP	
1-2	4.0 V.
2-3	4.0 V.
3-4	5.5 V.

RESISTANCE	
1-2	1400
2-3	1500
3-4	2000

Power Transformer Voltages

TERMINALS	A.C. VOLTS	SECONDARY
1		Center Tap for 280 Plate
2	2.67	Center Tap for 245 Tubes
3-4	2.68	Heaters of 224 and 227 Tubes
5-6	5.00	Filaments of 245 Tubes
8-9	7.50	Filament of 280 Tube
7-10		Plate of 280 Tube
Red Wire		Center Tap for 224 and 227 Tubes
Red Wire		Primary
Red Wire		Primary } Through panel together

Model 76.

Vol. Contr. set to max. - Line Volts: 115			
Tube Type	Location	Plate S.G. Volts	Cathode Plates Gr. Volts
24	1 R.F.	145	13.
24	2 R.F.	145	13.
24	Det.	36	12.
27	1 A.F.	140	10.
45	2 A.F.	250	30
45	2 A.F.	250	30
80	Rect.	4.5	50

PHILCO RADIO & TELEVISION CORP.

MODEL 87

Voltage Data
Condenser Data
Neutralization

is very critical, and must be done with extreme care. Remove the neutralizing tube and after taking the insulating material from the filament prong put the tube back into the socket. Repeat the above procedure for the second and then the first R. F. stage. It is important that the neutralizing be done with the volume control on full.

Philco Model 87 Receiver

tion. Remove the third (next to the detector) R. F. Tube, and after insulating one of the filament prongs put it back into the socket. When the neutralizing tube is inserted, the volume should be quite low. To properly neutralize this stage, turn the third neutralizing condenser with a fiber wrench, first one way then the other, until the minimum signal is obtained. This adjustment for minimum signal

Neutralizing: Use a neutralizing tube as described above and a good oscillator, such as is shown on Page 17, to neutralize the Philco Receiver.

When adjusting the Neutralizing Condensers connect the test lead from the oscillator to the ANT terminal. Have a good ground connection. Turn on the oscillator. With the Receiver turned on, tune it carefully until the oscillator signal is brought in at maximum strength. Have the oscillator coupler plug in for loud volume.

Table 3
Tube Socket Voltage

A.C. LINE VOLTS	1ST, 2D, 3D R. F. 1ST A. F.		DETECTOR		2D A. F.		RECTIFIER
	F. V.	P. V.	F. V.	P. V.	F. V.	P. V.	F. V.
125	1.5	90	2.5	30	2.5	245	5.0

Table 4
D. C. Voltage Across Filter Condenser Block

TERMINALS	D.C. VOLTS	CAPACITY	CIRCUIT
1-10	310	2.00 Mfd.	First Plate Filter Condenser
1-2	20	0.15 Mfd.	Across First Filter Choke
3-10	290	2.00 Mfd.	Second A. F. to Ground
4-10	155	1.00 Mfd.	Speaker Field to Ground
6-10	30	2.00 Mfd.	Detector Plate to Ground
5-10	96	1.00 Mfd.	R. F. and 1st A. F. Plates to Ground
7-10	45	0.10 Mfd.	B- of Second A. F. to Ground
8-9	110 A.C.	0.015 Mfd.	LOC Terminal Condenser

Table 5
Voltage Across "B-C" Resistor

TERMINALS	VOLTAGE DROP	TERMINAL	CIRCUIT
1-2	90	1	B+ for 226 Tubes
2-3	6	2	C+ and B- of 226 and 227 Tubes
3-4	45	3	Grounded C- of 226 and 245 Tubes
		4	C+ and B- of 245 Tubes

Table 6
Power Transformer Voltages

TERMINALS	A.C. VOLTS	SECONDARY
7-10	1.5	A.C. Filament of 226 Tube
8-11	2.5	A.C. Filament of 227 Tube
6-12	2.5	A.C. Filament of 245 Tubes
9	5.0	Center Tap of 245 Filament Secondary
4-5	5.0	A.C. Filament of Rectifier Tube
1-2	700.	A.C. Supply to Plate of Rectifier Tube
3		Center Tap of Rectifier Plate Secondary

POWER TRANSFORMER (30)

TERMINAL No.	COLOR OF CABLE WIRE	CONNECTION
1		Plate Rectifier (280) Tube
2		Plate Rectifier (280) Tube
3		Center Tap Grounded
4		Filament 280 Tube
5		Filament 280 Tube
6	Green with Yellow Tracer	Filament 245 Tube and Pilot
7	Black with White Tracer	Filament 226 Tube
8	Yellow	Heater 227 Tube
9	Green with Black Tracer	Terminal 7 of No. (21), Terminal 4 of No. (20)
10	White with Black Tracer	Filament 226 Tube
11	Yellow with Green Tracer	Heater 227 Tube
12	Green	Filament 245 Tubes and Pilot
	Green Rubber-Covered Wire	A.C. Supply
	Black Rubber-Covered Wire	A.C. Supply
	Yellow Rubber-Covered Wire	Terminal 3 of No. (20)

FILTER CONDENSER BLOCK (31)

1	White	Terminal of No. (22)
2-3	Black with Yellow Tracer (Two Wires)	Terminal of No. (22)
		*Right Lower Lug Electro-Dynamic Speaker Plug Jack
4	Blue	Terminal of No. (23)
		*Left Lower Lug Electro-Dynamic Speaker Plug Jack
5	Yellow with Green Tracer (Two Wires)	Terminal of No. (23)
6	Yellow	Terminal of No. (17)
7	Green with Black Tracer	Terminal of No. (22)
8	Blue with White Tracer	Terminal 9 of No. (20)
9	Black	Terminal of No. (24)
10		Local on Binding Post Strip Grounded

MODEL 90, 90-A
(With 2-45s)
Chassis-Data

PHILCO RADIO & TELEVISION CORP.

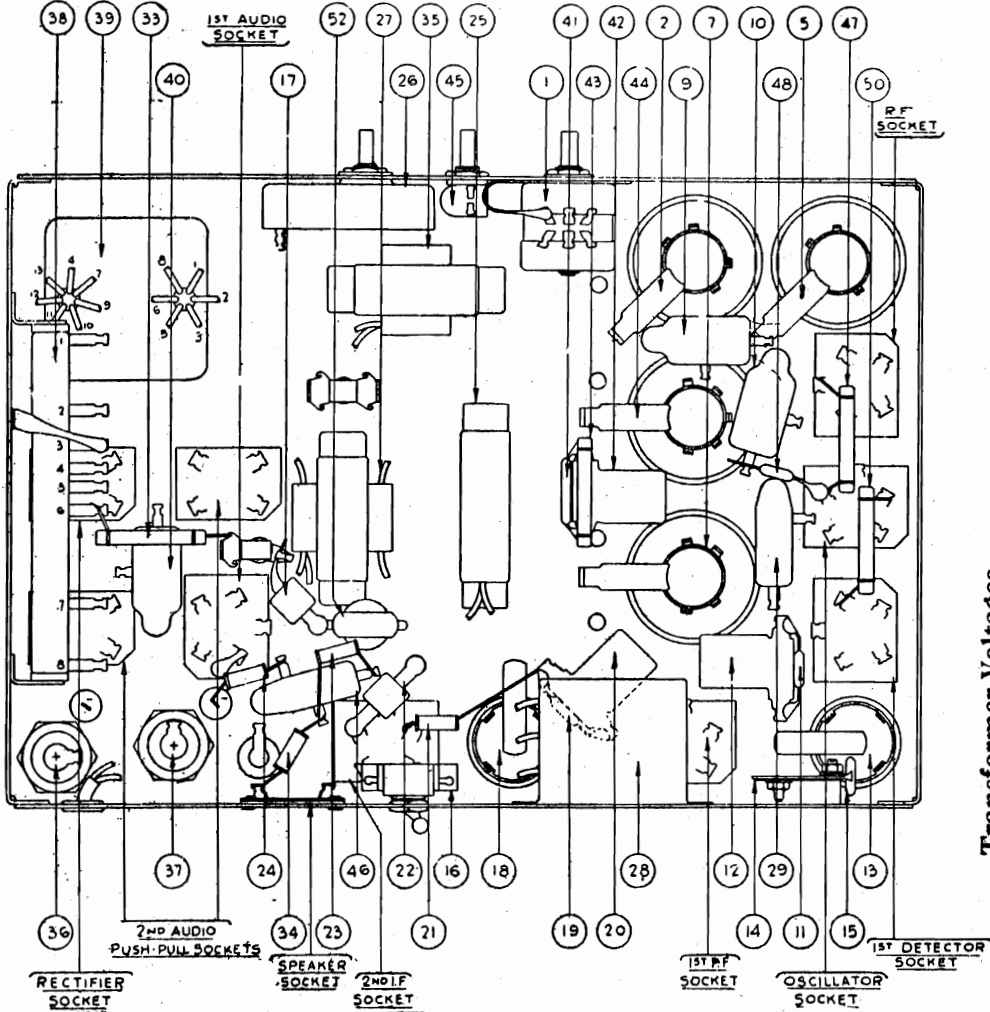

Transformer Voltages

A.C. Volts	Color
105 to 125	Black (Small Gauge)
2.5	Black (Heavy Gauge)
2.5	Black with Yellow
2.5	Dark Green
2.5	Black with Green
5.0	Light Blue
650	Yellow
...	Yellow with Green

Terminals	Color
1-2	Primary
3-5	Heaters of 24 and 27 Tubes
4	Center Tap of 3-5
6-8	Filament of 45 Tubes
7	Center Tap of 6-8
9-10	Filament of 80 Tube
11-13	Plates of 80 Tube
12	Center Tap of 11-13

No. on Figs.	Capacity	Color
8	.09 Double	Black Bakelite Container
10	.09 Double	Black Bakelite Container
11, 15, 16, 20, 48	.00011	Blue, Golden Yellow
17, 22	.000035	Yellow and Green
25	.5	Metal Container
26	.25 Double (Black wires to Ground) .5 (White wire to Ground)	Metal Container
27		
28	.05	Black Bakelite Container
29	6.	Electrolytic Type
30 (25 to 40 cycles)	10.	Electrolytic Type
31	.015 Double	Black Bakelite Container
32	.0007	White, Golden Yellow
33	.001	Green and White

Condenser Data

Resistor Data

No. on Fig.	Terminal	Power (Watts)	Resistance	Color Body—Tip—Dot
38	1-2	...	800	(Long Tubular)
	2-3	...	263	
	3-4	...	75	
	5-6	...	370	
	6-7	...	1,800	
	7-8	...	1,430	
	...	1.	13,000	
5	50,000	
47	...	1.	50,000	Brown—Orange—Orange
	...	1.	250,000	
5	250,000	
5	1,000,000	
5	1,000,000	

PHILCO RADIO & TELEVISION CORP.

MODEL 90, 90-A
(With 2-145s)
Schematic
Voltage

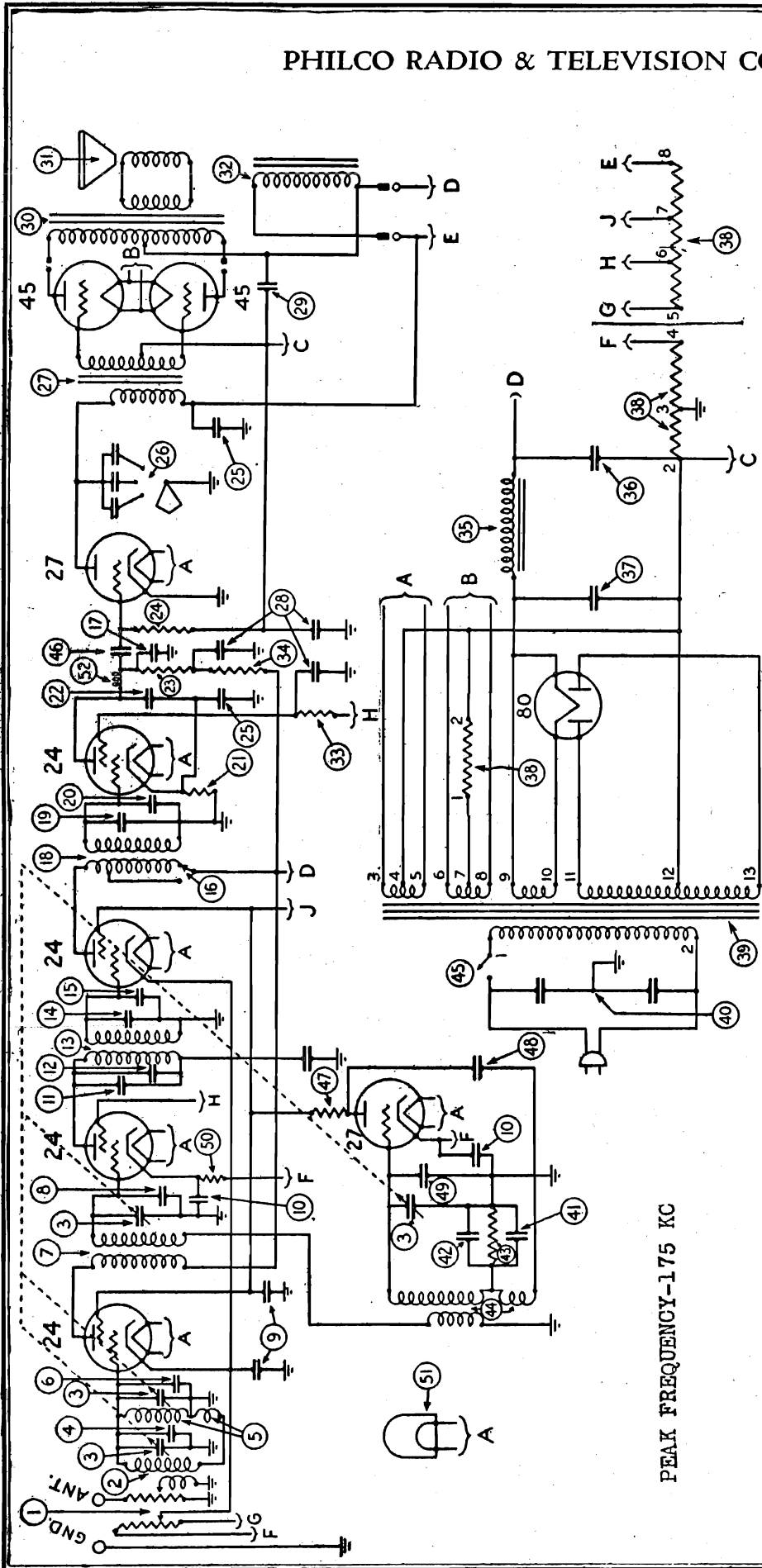
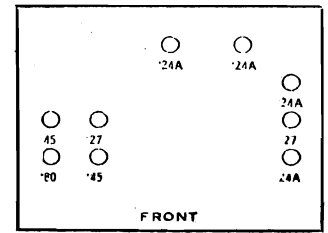

Table 1—Tube Socket Readings Taken with AC Set Tester, AC Line, 115 Volts

Tube Type	Circuit	Filament Voltage	Plate Voltage	Grid Voltage	Screen Grid Voltage	Cathode Voltage	Plate Milliamperes
24	1st R. F.	2.1	250	3.3	83	15	3
27	Osc.	2.1	60	1	23	15	2
24	1st Det.	2.1	250	5.5	80	15	.5
24	1st I. F.	2.1	250	3.8	42	15	4.5
24	2nd Det.	2.1	48	3.7	...	10	3
27	1st Audio	2.1	140	.25	30
45	Audio	2.2	243	46	30
45	Rect.	4.5	243	46

All readings taken with antenna disconnected and ground on. Volume Control on full.

Models 90, 90A Early Type



PEAK FREQUENCY-175 KC

PHILCO RADIO & TELEVISION CORP.

MODEL 90, 90-A
(With 2-45s)
Parts List

RANGE SWITCH

The Range Switch, No. ⑩ in Fig. 1, is placed in the NORMAL position when the Receiver is shipped. This gives great distance range and is the setting which will be found most satisfactory in practically all locations. In places far from broadcasting stations, however, the Range Switch may be changed to the MAXIMUM position. This will make the Receiver super-sensitive and will give extreme distance range. Do not use the Range Switch in the MAXIMUM position if there are one or more powerful broadcasting stations near you. In any location there will be less noise between stations with the Range Switch in the NORMAL position.

REPLACEMENT PARTS—MODELS 90 AND 90-A

No. on Figs. 3 and 4	Description	Part No.	No. on Figs. 3 and 4	Description	Part No.
①	Volume Control	5039	③⑧	Power Transformer (50 to 60 cycles)	4938
②	1st R. F. Transformer	03013		Power Transformer (25 to 40 cycles)	4939
③	Gang Condenser—50 to 60 cycles	03001	④⑩	Condenser .015 M. F. (Double)	3793-E
	Gang Condenser—25 to 40 cycles	03078	④⑪	Condenser .0007 M. F. } Assembled	03050
④	Compensating Condenser (Part of Tuning Condenser Assembly)		④⑫	Compensating Condenser }	4237
⑤	2nd R. F. Transformer	03014	④⑬	Resistor—50,000 Ohms	4237
⑥	Compensating Condenser (Part of Tuning Condenser Assembly)		④⑭	Oscillator Coil	03016
⑦	1st Det. Transformer	03015	④⑮	On-Off Switch	4095
⑧	Compensating Condenser (Part of Tuning Condenser Assembly)		④⑯	Condenser .001 M. F.	5215
⑨	Condenser .09 M. F. (Double)	4989-C	④⑰	Resistor—13,000 Ohms	3766
⑩	Condenser .09 M. F. (Double)	4989-B	④⑱	Condenser .00011 M. F.	4519
⑪	Fixed Condenser .00011 } Assembled	3772-C	④⑲	Compensating Condenser (Part of Tuning Condenser Assembly)	
⑫	Compensating Condenser }		④⑳	Resistor—5,000 Ohms	3526
⑬	1st I. F. Transformer	03009	④㉑	Pilot Bulb	3463
⑭	Compensating Condenser } Assembled	03051	④㉒	R. F. Choke	03086
⑮	Fixed Condenser .00011 }	03051		Line Cord and Plug	L-943
⑯	Normal Maximum Switch	3116		Tube Shield	03002
⑰	Condenser (.000035 mf)	4990		Knob (large) Dial Control	03063
⑱	2nd I. F. Transformer	03143		Spring (Dial Knobs)	4147
⑲	Compensating Condenser } Assembled	03051		Knobs (small) Tone and Volume Control	4959-A
⑳	Fixed Condenser .00011 }	03051		Knob (switch)	4290-A
㉑	Resistor—50,000 Ohms	4518		Grid Clip	4897
㉒	Condenser .00035	4990		Speaker Plug and Cable	L-1124-A
㉓	Resistor—250,000 Ohms	4410		Grommet for R. F. Transformer Shield	3747
㉔	Resistor—1,000,000 Ohms	4409		Rectifier Tube Socket	5026
㉕	Condenser .5 M. F. (Double)	03024		Four Prong Socket Assembly	4955
㉖	Tone Control	4037-A		Five Prong Socket Assembly	4956
㉗	1st Audio Transformer	4952		Speaker Socket	4957
㉘	Condensers 2—.25 M. F. and 1—.5 M. F.	03029		Volume Control Insulator	4092
㉙	Condenser .05 M. F.	3615-C		Volume Control Insulator	4286
㉚	Output Transformer:			Fahnstock Clip	L-1126
	H ₂ (For Large Cone Assembly)	2848		Mica for Gang Condenser Compensating Condenser	3473
	K ₂ (For Small Cone Assembly)	2766		Insulating Washer for Compensating Condenser	3500
㉛	Voice Coil Assembly and Cone:			Tuning Condenser Mounting Washer	3914
	H ₂ (Large Cone)	02997		Tuning Condenser Mounting Washer	3915
	K ₂ (Small Cone)	02996		Tuning Condenser Mounting Sleeve	3916
㉜	Speaker Field—Assembled with Pot and Frame (H ₂)	02986		Spring for Tuning Condenser	4255
	Speaker Field—Assembled with Pot and Frame (K ₂)	02985		Bezel	5009
㉝	Resistor—250,000 Ohms	3768		Complete Drive Bracket	03011
㉞	Resistor—250,000 Ohms	4410		Disc Dial Assembly	03031
㉟	Filter Choke	4951		Knob Spring—Volume, Tone, Dial	5262
㊱	Condenser 6 M. F. Electrolytic Type (50-60 cycles)	4916		Steel Washer (Chassis Mtg.)	5058
	Condenser 10 M. F. Electrolytic Type (25-40 cycles)	5142		Nut—Volume, Tone Control Switch	W-434
㊲	Condenser 6 M. F. Electrolytic Type (25-40) and (50-60) cycles	4916			
㊳	B. C. Resistor	4953			

Several changes in wiring and part numbers have been made in the Model 90. The filter choke part 4951 has been changed to part 4819, the same choke as used in Model 21. On the 50-60 cycle models, a .09 mfd condenser, part 4989-J, is connected across the filter choke, part 4819. On the 25 cycle models, this condenser should be .18 mfd, part 4989-H ungrounded. The two 240,000 resistors part 4410, numbers (32) and (35) should be of the Continental Carbon type. This is the resistor without metal ends.

In the Model 90, a metal shield, part 03646, is placed in a bracket between the '47 and '80 tubes.

If electrolysis occurs on the insulation of the wire between the filter choke and one of the electrolytic condensers, unsolder the wire and cover with spaghetti.

Condenser Bank
Connections
Condenser
Color Code

PHILCO RADIO & TELEVISION CORP.

Internal Connections of Condenser Banks

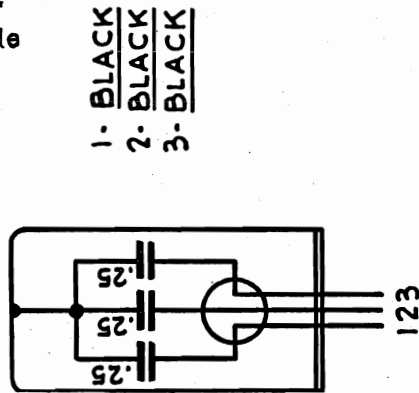

- 1- BLACK
- 2- BLACK
- 3- BLACK

Part 03325
Models 90 - 90-A
Above Serial No. 237,001

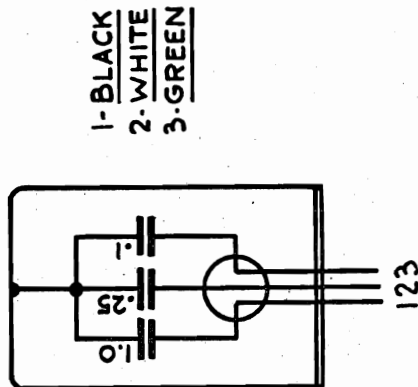

- 1- BLACK
- 2- WHITE
- 3- GREEN

Part 03327
Model 90
Above Serial No. 237,001

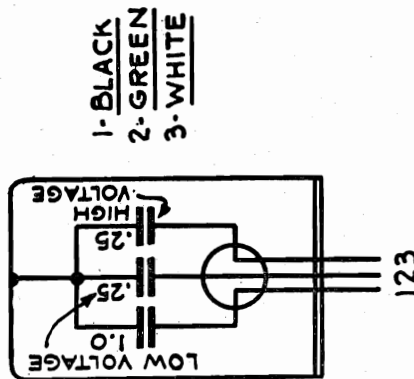

- 1- BLACK
- 2- GREEN
- 3- WHITE

Part 03624
Model 90-A
Above Serial No. 112,977

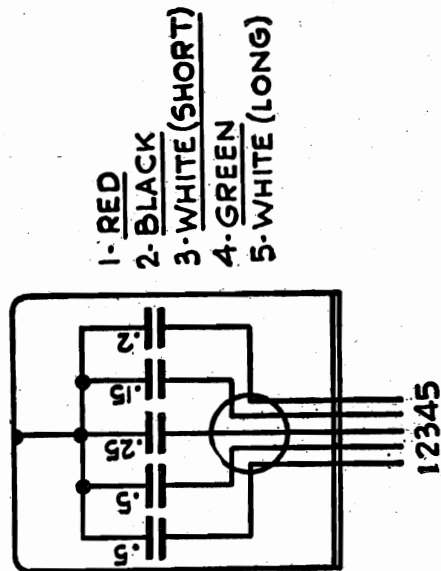

- 1- RED
- 2- BLACK
- 3- WHITE (SHORT)
- 4- GREEN
- 5- WHITE (LONG)

Part 03455
Model 50-A

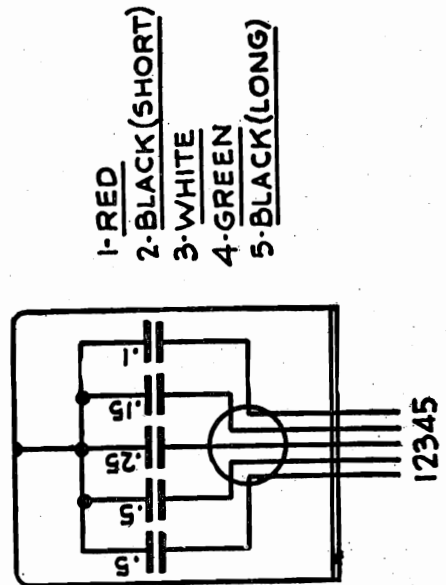

- 1- RED
- 2- BLACK (SHORT)
- 3- WHITE
- 4- GREEN
- 5- BLACK (LONG)

Part 03459
Model 50

CONDENSER DATA

COLOR CODING USED ON ALL PHILCO RECEIVERS

PART NO.	CAPACITY MF.	COLOR	PART NO.	CAPACITY MF.	COLOR
3082	.00025	Yellow	4519	.00011	Blue and Golden Yellow
3774	.00005	White	4520	.0007	White and Golden Yellow
3910	.0005	Green	4587*	.00005	Light Blue and White
4059	.002	Light Blue	5120	.00041	Yellow & Orange

*Note: Part No. 4587 is held to closer tolerance limits than Part No. 3774.
Do not substitute either of these condensers, use the part numbers given.

PHILCO RADIO & TELEVISION CORP.

MODEL 90, 90-A
(With 1-'47)
Schematic
Voltage

(Above Serial No. 237,001)

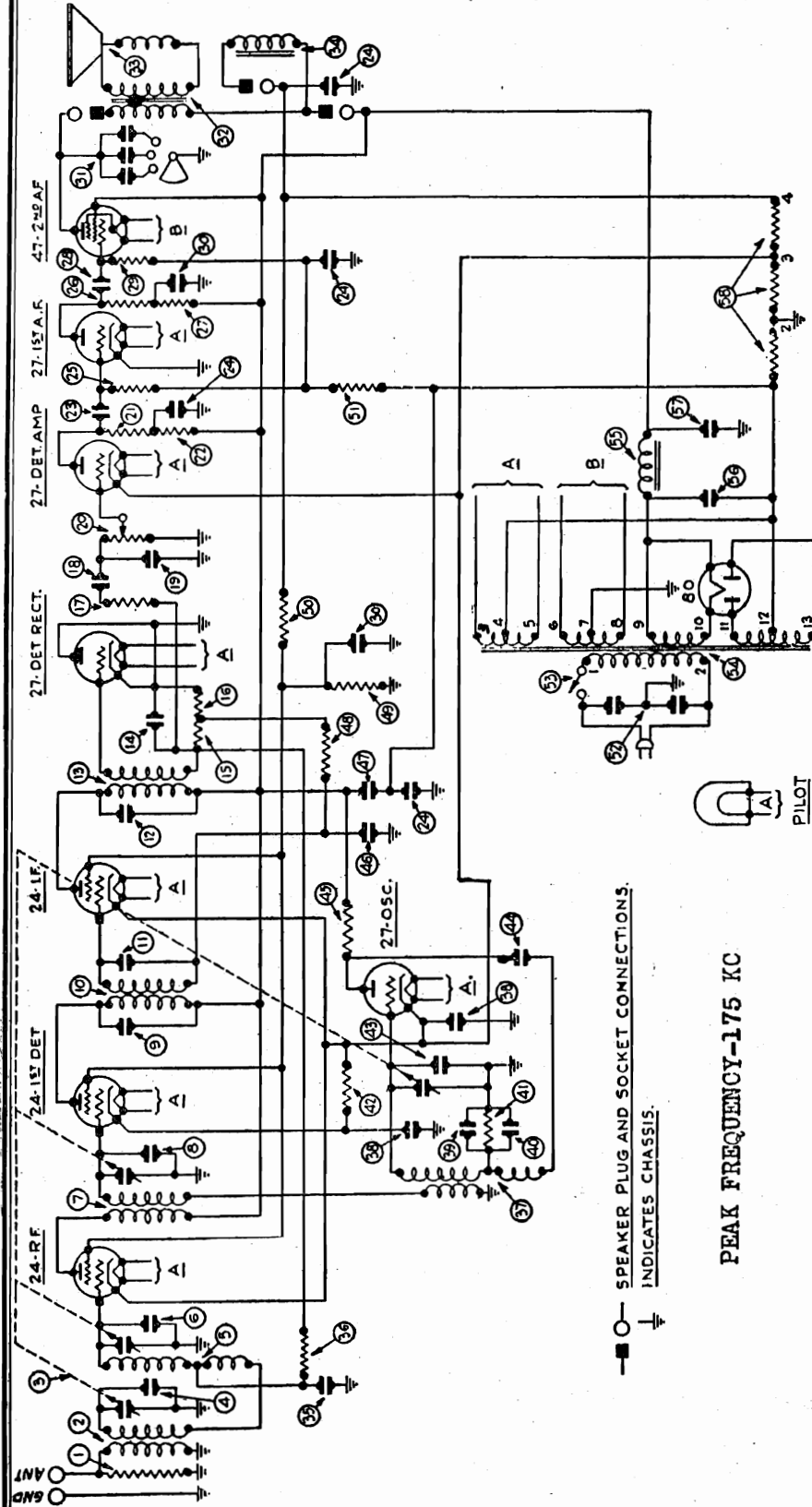

PEAK FREQUENCY-175 KC

Table 1—Tube Socket Readings Taken with AC Set Tester, AC Line, 115 Volts

Tube Type	Circuit	Filament Volts	Plate Volts	Screen Grid Volts	Control Grid Volts	Cathode Volts	Plate Milliamperes
24	R. F.	2.0	255	60	.25	20	2.4
27	Osc.	2.0	65	..	.6	20	3.6
24	1st Det.	2.0	250	64	6.0	24	.25
24	I. F.	2.0	270	.76	.25	18	.4
27	Det. Rect.	2.0	'0	..	0	17	0
27	Det. Amp.	2.0	140	..	.4	18	2.0
27	1st. A. F.	2.0	45	..	.4	20	1.8
47	Output	2.0	220*	240*	1.0*	..	32.*
80	Rectifier	4.5					

All readings taken with antenna disconnected and ground on. Volume Control on full.
*These readings must be taken from the underside of the chassis using test prods and leads unless the set checker is specially equipped for testing pentode tubes.

—■— SPEAKER PLUG AND SOCKET CONNECTIONS.
- - - - - INDICATES CHASSIS.

Models 90, 90A, 90E Later Type

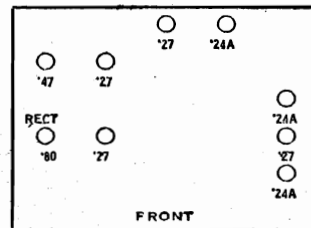

PHILCO RADIO & TELEVISION CORP.

MODEL 90,90-A
(With 1-'47)
Chassis-Data

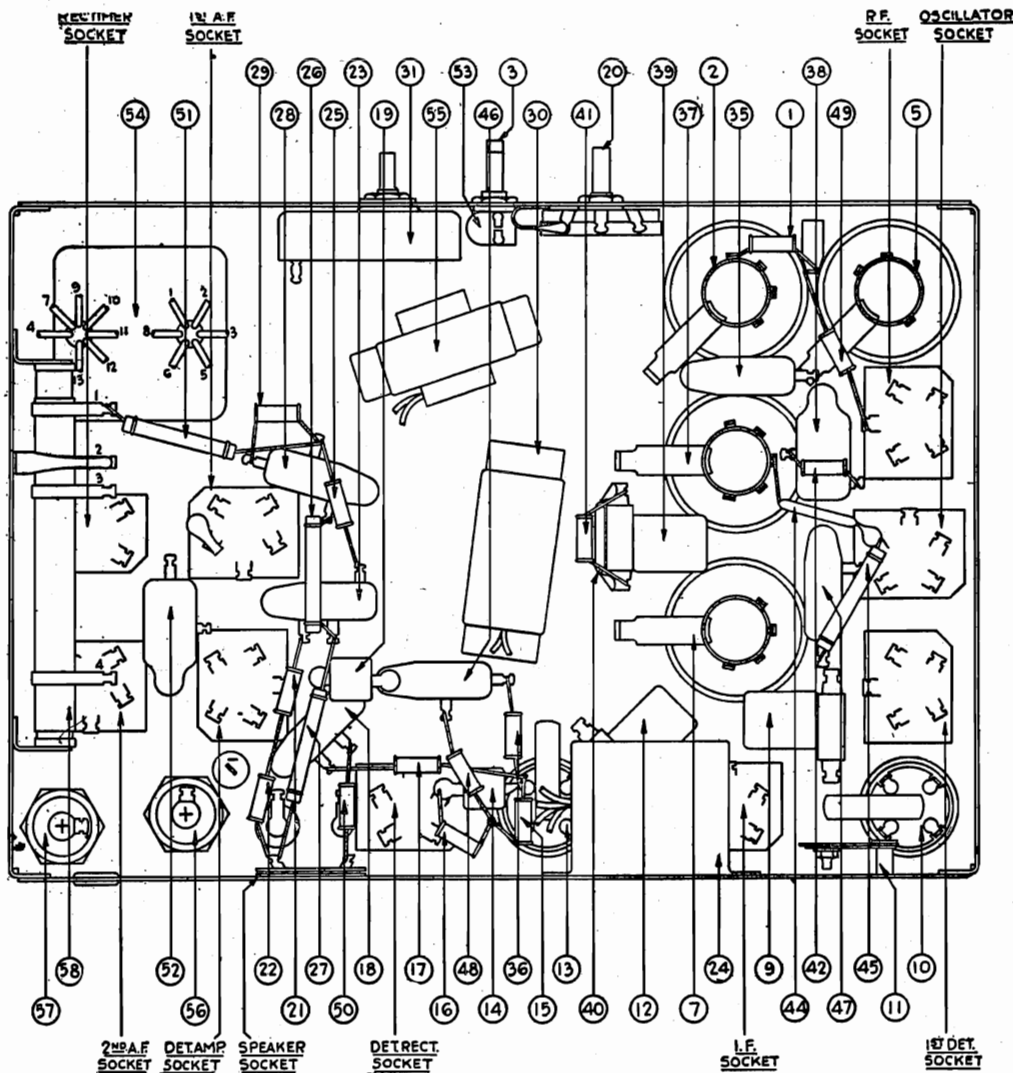

Table 2—Power Transformer Voltages

Terminals	A.C. Volts		Color
1-2	105 to 125	Primary	White
3-5	2.5	Heaters of 24 and 27 Tubes	Black
4	2.5	Center Tap of 3-5	Black with Yellow
6-8	2.5	Filament of 47 Tube	Dark Green
7	2.5	Center Tap of 6-8	Black with Green
9-10	5.0	Filament of 80 Tube	Light Blue
11-13	650.	Plates of 80 Tube	Yellow
12	...	Center Tap of 11-13	Yellow with Green

Table 3—Resistor Data

No. on Figs. 1 and 2	Terminal	Power (Watts)	Resistance (Ohms)	Color		
				Body	Tip	Dot
53	{ 1-2 2-3 3-4 }	1.	180	(Long Tubular)		Red
			60			
			3,500			
12		.5	5,000	Green	Black	Red
			10,000	Brown	Black	Orange
29		1.0	25,000	Red	Green	Orange
			25,000	Red	Green	Orange
16		.5	51,000	Green	Brown	Orange
			51,000	Green	Brown	Orange
22		.5	70,000	Violet	Black	Orange
			99,000	White	White	Orange
25		.5	240,000	Red	Yellow	Yellow
			240,000	Red	Yellow	Yellow
26		.5	490,000	Yellow	White	Yellow
			490,000	Yellow	White	Yellow

Table 4—Condenser Data

No. on Figs. 1 and 2	Capacity	Color
53	.00011	Blue, Golden Yellow
	.00025	Yellow
12	.01	Black Bakelite Container
	.05	Black Bakelite Container
29	.09	Black Bakelite Container
	.1-13-.25-1.	Black Bakelite Container
16	.25-1.	Metal Container
	(50-60 Cycles) 6.	Electrolytic Type
22	(25-40 Cycles) 10.	Electrolytic Type
25		
26		
57		

MODEL 90,90-A
(With 1-47)
Test Data

PHILCO RADIO & TELEVISION CORP.

From Chassis To **Correct** **Incorrect**

Speaker field only 3,200 ohms Incorrect

Oscillator Control Grid 51,006.5ohms Includes section used in plate circuit

Oscillator Winding only 6.5ohms BC-Osc K-Y

Oscillator Cathode 60 ohms 51,000 ohms

Oscillator Plate to '47 Screen 199 ohms FC

'80 Anode to '80 Anode 280 ohms

'80 Anode to Chassis 0 ohm

'80 Anode to '80 Fil FC

Note**

Fixed condenser between Det-Amp Plate and 1 AF-Cg 3.26 ohms BC across primary

Fixed condenser between 1 AF Plate and '47 Cg 0 ohm BC- across primary

Resistor of 99,000 between AVCX Cg wdg and coupling condenser to Det-Amp volume control

Across AC Plug 3.26 ohms BC across primary

AC plug to chassis 0 ohm BC- across primary

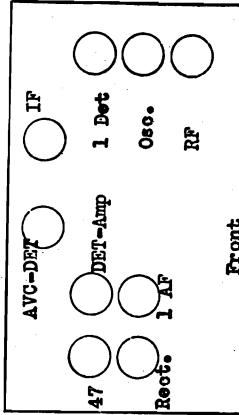

All tubes out of sockets and AC plug disconnected from power supply.
Speaker field and output transformer disconnected.

From Chassis To **Correct** **Incorrect**

Aerial 10.7 ohms Fixed resistor across antenna coil

RF Control Grid to First Selector 13.4 ohms BC- rf Cg wdg-Y

Condenser Stator 592,000 ohms BC- AVCX wdg-Y

RF Control Grid to Chassis 60 ohms BC- if Cg wdg-Y

RF Cathode 20,280 ohms TC- rf Cg-Y

RF Screen Grid 168.7 ohms BC- Osc K-Y

RF Plate to 80 Fil 18.7 ohms BC- Field coil pocket-

RF Plate to '47 Screen 7.9 ohms Y

1 Detector Control Grid 5,060 ohms TC- 1 D Cg-Y

1 Detector Cathode 20,280 ohms BC- 1 D K-Y

1 Detector Screen Grid 218 ohms BC- Osc K-Y

1 Detector Plate to '80 Fil 68 ohms See RF Screen

1 Detector Plate to '47 Screen 541,068 ohms TC- IF Tr

IF Control Grid 60 ohms BC- IF Cg wdg-Y

IF Cathode 20,280 ohms TC- IF Tr

IF Screen Grid 70 ohms See 1 Detector Cathode

IF Plate to '47 Screen 110,080 ohms See RF Screen

AVCX Control Grid 0 ohm TC- IF Tr

AVCX Cathode 0 ohm BC- AVCX Cg wdg-Y

AVCX Plate 0 ohm

AVCX Cathode to Plate 0 ohm

Det-Amp Control Grid (V.C.Min) 0 ohm

DET-Amp Control Grid (V.C.Max) high resistance - exact value unknown

Det-Amp Cathode 60 ohms BC- Osc K-Y

Det-Amp Plate to '47 Screen 121,000 ohms BC-70,000-Y

1 AF Control Grid 480,180 ohms BLC-Det Amp-P- 1 AF Cg

1 AF Cathode 0 ohms See Det-Amp Plate

1 AF Plate to '47 Screen 50,000 ohms BC-240,000 ohms-Y

'47 Control Grid 480,000 ohms BC-25,000 ohms-Y

'47 Screen Grid to '80 Fil 0 ohm BC-'47 Cg resistor-Y

'47 Plate to Chassis 0 ohm Tone control cond

Output Transformer Primary only 462 ohms

Output Transformer Secondary only 0.106 ohm

-Tube Socket Readings Taken with AC Set Tester, AC Line, 115 Volts

Type	Tube	Current	Plate Volt	Screen Grid Volt	Control Grid Volt	Case Volt	Base Milliamperes
24	R. F.	2.0	255	60	25	20	2.4
27	Osc.	2.0	65	..	6	20	3.6
24	1st Det.	2.0	250	64	6	24	.25
27	Det. Rect.	2.0	270	70	0	17	0
27	Det. Amp.	2.0	140	..	4	18	2.0
27	1st A. F.	2.0	45	..	4	20	1.8
87	Output Rectifier	4.9	250*	240*	1.0*	20	3.2*

All readings taken with antenna disconnected and ground on. Volume Control on full.
*These readings may be taken from the underside of the chassis using test prods and leads unless the set checker is specially equipped for testing pentode tubes.

PHILCO RADIO & TELEVISION CORP.

MODEL 90,90-A
(With 1-47)
Parts List

ADJUSTMENT OF MODELS 90 and 90-A

These Receivers are accurately adjusted at the Factory prior to their shipment. Under no circumstances are the adjusting condensers to be changed in the field. This alignment requires special oscillator equipment, which all Philco Distributors have. If for any reason the Receiver needs adjustment it must be returned to the Distributor's Service Department.

REPLACEMENT PARTS—MODELS 90 and 90-A RECEIVERS

(Above Serial No. 237,001)

No. on Figs. 3 and 4	Description	Part No.	No. on Figs. 3 and 4	Description	Part No.
①	Resistor (10,000 ohms)	4412	③⑧	By-Pass Condenser (.09 mfd.) double	4989-G
②	First R. F. Transformer	03360	③⑨	Compensating Condenser } Assembled	03050
③	Gang Condenser (50-60 cycles)	03001	④⑩	Condenser (.0007 mfd.)	4518
	Gang Condenser (25-40 cycles)	03078	④⑪	Resistor (51,000 ohms)	
④	Compensating Condenser (part of gang condenser assembly)		④⑫	Resistor (5,000 ohms)	5310
⑤	Second R. F. Transformer	03014	④⑬	Compensating Condenser (part of tuning condenser assembly)	
⑥	Compensating Condenser (part of gang condenser assembly)		④⑭	Condenser (110 mmf.)	4519
⑦	First Detector Transformer	03015	④⑮	Resistor (51,000 ohms)	4237
⑧	Compensating Condenser (part of gang condenser assembly)		④⑯	By-Pass Condenser (.05 mfd.)	3615-U
⑨	Compensating Condenser (First I. F. Primary)	03315 04000L	④⑰	By-Pass Condenser (.05 mfd.)	3615-E
⑩	First I. F. Transformer	03009	④⑱	Resistor (490,000 ohms)	4517
⑪	Compensating Condenser (First I. F. Secondary)	03315	④⑲	Resistor (70,000 ohms)	5385
⑫	Compensating Condenser (Second I. F. Primary)	03317	④⑳	Resistor (25,000 ohms)	4516
⑬	Second I. F. Transformer	03345	④㉑	Resistor (240,000 ohms)	3768
⑭	Condenser (110 mmf.)	4519	④㉒	Condenser (.015 mfd.) double	3793-E
⑮	Resistor (51,000 ohms)	4518	④㉓	On-Off Switch	4095
⑯	Resistor (51,000 ohms)	4518	④㉔	Power Transformer (50-60 cycles).	5362
⑰	Resistor (99,000 ohms)	4411		Power Transformer (25-40 cycles).	5363
⑱	By-Pass Condenser (.01 mfd.)	3903-M		Power Transformer (50-60 cycles, 220 volts)	5364
⑲	Condenser (.00025 mfd.)	3082	④㉕	Choke	4951
⑳	Volume Control	5366	④㉖	Condenser (6 mfd.) Electrolytic type (50-60 cycles)	4916
㉑	Resistor (51,000 ohms)	4518		Condenser (10 mfd.) Electrolytic type (25-40 cycles)	5142
㉒	Resistor (70,000 ohms)	5385	④㉗	Condenser (6 mfd.) Electrolytic type (50-60 cycles)	4916
㉓	By-Pass Condenser (.01 mfd.)	3903-M		Condenser (10 mfd.) Electrolytic type (25-40 cycles)	5142
㉔	Condenser (1-1 mfd., 1-13 mfd., 2-25 mfd.)	03325	④㉘	B. C. Resistor	5365
㉕	Resistor (240,000 ohms)	4410		Line Cord and Plug	L-943
㉖	Resistor (25,000 ohms)	3656		Tube Shield (Large)	03373
㉗	Resistor (25,000 ohms)	3656		Tube Shield (27 type)	5387
㉘	By-Pass Condenser (.01 mfd.)	3903-P		Pilot Bulb	3463
㉙	Resistor (240,000 ohms)	4410		Pilot Bracket Complete	03081-A
㉚	Condenser (.25 mfd., 1 mfd.)	03327		Knob (Large)	4958-A
㉛	Tone Control	4037-A		Knob (Small)	4959-A
㉜	Output Transformer	2673		Knob (Switch)	4290-A
㉝	Voice Coil Assembly and Cone: H ₂ (Large Cone)	02997		Spring (For small knobs)	4147
	K ₂ (Small Cone)	02996		Spring (For large knobs)	5262
㉞	Speaker Field (Assembled with pot and frame)			Grid Clip	4897
㉟	By-Pass Condenser (.05 mfd.)	3615-W		Five Prong Socket Assembly	4956
㊱	Resistor (490,000 ohms)	4517		Four Prong Socket Assembly	4955
㊲	Oscillator Coil	03016		Volume Control Insulator	4092
				Dial	5021
				Light Shield Screen	4937
				Bezel	5009

MODEL 90, 90-A
Alignment

PHILCO RADIO & TELEVISION CORP.

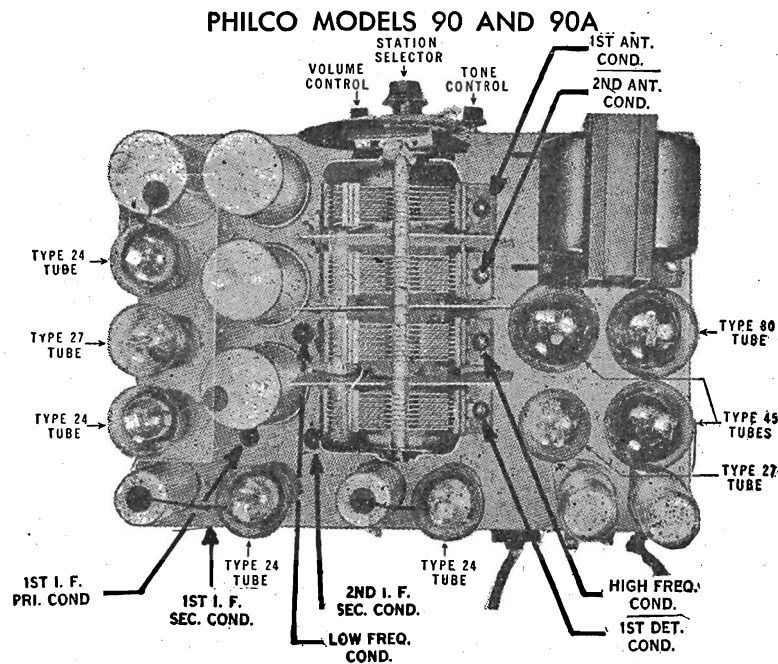

Adjusting the Model 90 Using a Jewell 560 Oscillator

Set up the Receiver for operation using standard tubes. Set the Normal-Maximum switch in the Normal position.

Intermediate Frequency Adjustment—Remove the tube shield. Remove the control grid clip of the first detector tube (Type 24 tube nearest back of the Receiver Chassis under the tube shield). Connect the "A" terminal of the oscillator to the control grid of the first detector tube. The "G" terminal must be connected to the Receiver Chassis. Turn the filament control of the oscillator on about $\frac{1}{2}$ the total movement. The middle switch must be turned to the intermediate position. The tuning control of the oscillator must be set for exactly 175 K.C., as indicated in the calibration data sent with the instrument.

Turn the volume control of the Receiver on full. Set the attenuator control so that an audible signal is received in the speaker. Connect the \pm and the low terminals of the output meter to the voice coil terminals of the speaker. Adjust the attenuator control for not more than $\frac{1}{2}$ full scale reading of the meter.

Using a Philco part No. 3164 fibre wrench, adjust the second I. F. secondary condenser for maximum reading in the output meter. Adjust the first I. F. secondary and then the first I. F. primary condensers for maximum reading in the output meter. Reduce the oscillator signal to prevent any damage to

the meter mechanism. Replace the grid clip on the first detector tube and replace the tube shield.

High Frequency Compensator—Connect the "A" and "G" terminals of the oscillator to the ANT and GND terminals of the Receiver. Do not change the oscillator setting. Tune the Receiver to exactly 140 and adjust the high frequency compensator for maximum reading in the output meter.

Antenna and Detector Condensers—With the Receiver and oscillator in the same setting, set the detector and antenna condensers for maximum reading in the output meter. If the Receiver is so far out of adjustment that the signal is extremely weak when adjusting the high frequency condenser it is advisable to temporarily check the adjustment of the detector and antenna condensers. Final adjustment of these condensers must be made as described.

Low Frequency Condenser—With the oscillator turned to broadcast frequency set the Philco scale at 60 and adjust the low frequency compensating condenser for maximum signal in the output meter. If the signal comes in off the 60 position on the Philco scale, set the Receiver slightly off the signal towards 60 and adjust the signal for maximum strength in this position. By repeating this, you will be able to bring the signal up to the 60 setting on the Philco scale.

PHILCO RADIO & TELEVISION CORP.

MODEL 96,96-A
Chassis

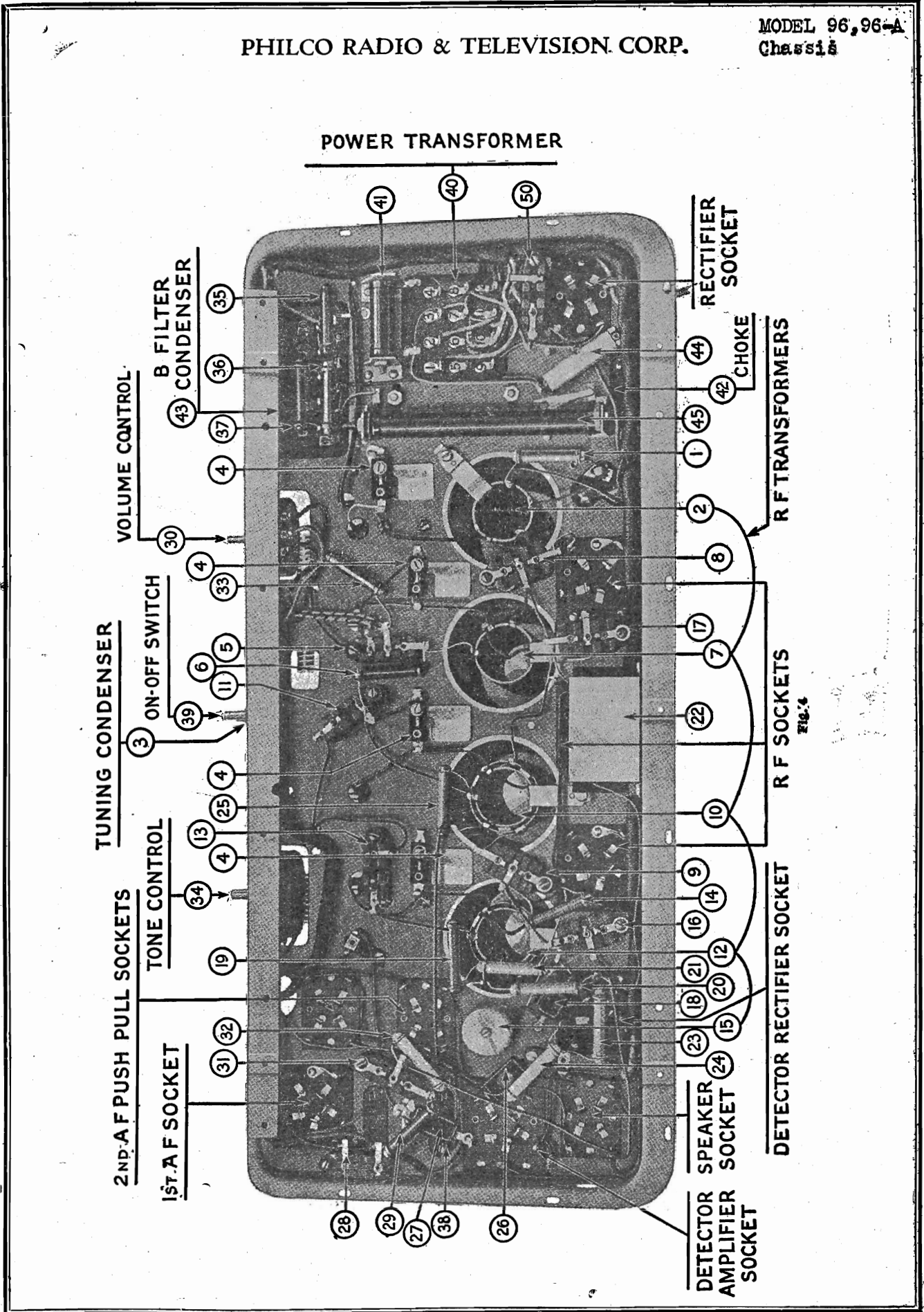

2ND. A F PUSH PULL SOCKETS
 1ST. A F SOCKET
 TUNING CONDENSER
 ON-OFF SWITCH
 TONE CONTROL
 VOLUME CONTROL
 B FILTER CONDENSER

RECTIFIER SOCKET
 CHOKE
 R F TRANSFORMERS
 R F SOCKETS
 DETECTOR RECTIFIER SOCKET
 DETECTOR SPEAKER AMPLIFIER SOCKET
 DETECTOR RECTIFIER SOCKET

MODEL 111,111-A
Voltage
Electrical Values

PHILCO RADIO & TELEVISION CORP

Table 1—Tube Socket Readings Taken with AC Set Tester AC Line—115 volts

Tube		Filament Volts	Plate Volts	Screen Grid Volts*	Control Grid Volts	Cathode Volts	Plate Milli-Amperes	Screen-Grid Milli-Amperes †
Type	Circuit							
24	1st R. F.	2.1	190	60	.2	5	1.7	1.75
27	Osc.	2.1	45	..	.7	7	1.6
24	1st Det.	2.1	180	62	4.6	8	.5†	.15
24	1st I. F.	2.1	185	65	...	5	1.5	1.7
24	2nd I. F.	2.1	190	82	2.2	5	3	1.85
27	Det. Rect.	2.24	.5
27	Det. Amp.	2.2	35	..	.4	5	.20†
27	1st A. F.	2.1	95	..	1.2	5	4.
45	2nd A. F.	2.2	255	..	50	...	32.5
45	2nd A. F.	2.2	255	..	50	...	32.5
80	Rect.	4.9	50/Plate

*Read with C 100 Scale.
†Read with 20 Mil. Scale.
‡Read with 2 Mil. Scale.

Note—Volume Control Off; Station Selector turned to Low Frequency End; Range Switch set in "Normal" Position.

Table 2—Power Transformer Voltages

Terminals	A.C. Volts	
1—2		Primary
3		Center Tap 80 Tube
4		Center Tap 45 Tubes
5—6	2.67	Heaters for 24 and 27 Tubes
7—8	2.68	Filaments for 45 Tubes
9—12	750.	Plates 80 Tube
10—11	5.0	Filament 80 Tube
Rubber Covered Lead		Center Tap for 24 and 27 Tubes

Condenser Data
(Other than Filter Condenser)

Resistor Data

No. on Diagram	Capacity	No. on Diagram	Resistance	Color
⑥	.05	①	10,000	Black
⑩ ⑪	.05 and 250 Ohm Resistor	⑧ ③⑨ ④① ⑥⑥ ⑥⑧	100,000	Silver Gray—Yellow Tip
⑰	.25 (two sections)	⑰	50,000	Orange
⑰ ⑲ ⑳ ㉓ ㉕	.00011	⑱	13,000	Belgium Blue
㉑	.0007	㉒	1,000	Brown Body—Black Tip—Red Dot
㉔	.05	㉔	500,000	Battleship Gray
㉖	.05 and 250 Ohm Resistor	㉖	500,000	Battleship Gray
㉗	.00005	㉗	250,000	White
㉘	.5	㉘—㉙	70,000	Jade Green
㉚	.00025	㉚—㉛	25,000	Auto Brown—Yellow Tip
㉜	.015	㉜	10,000	Long Tubular
㉝	.05	㉝	70	Flat Wire Wound (two sections)
㉞	.015 (two sections)	㉞	800	Short Tubular
㉟	.05			

Model 211 Condenser Block Part No. 3754

Model 211-A Condenser Block Part No. 3755

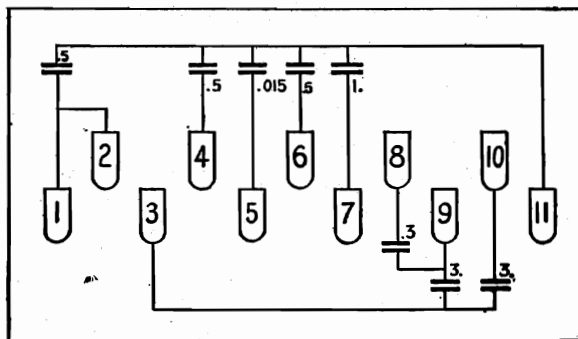
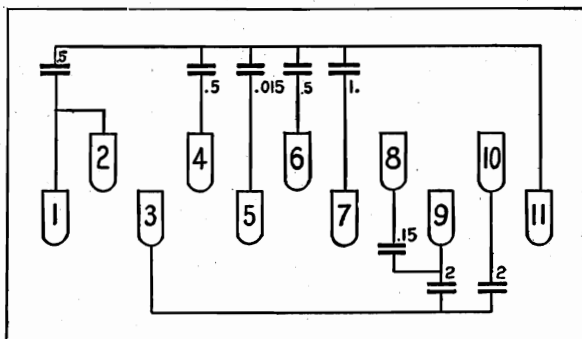

PHILCO RADIO & TELEVISION CORP.

MODEL 111, 111-A
Schematic
Socket

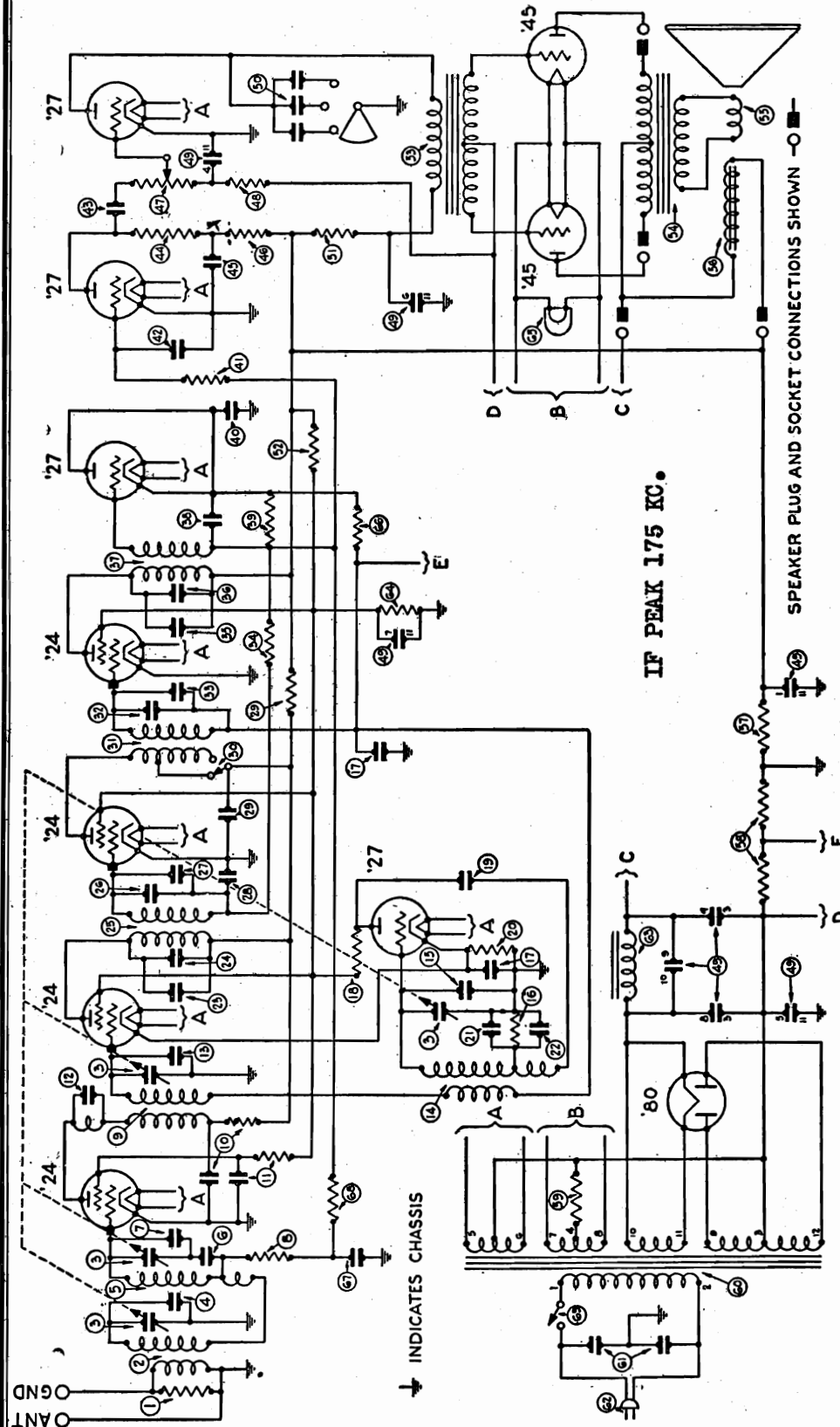

NOTE: The connection shown between Condenser No. ② and Condenser No. ③ should also be connected to ground.
Models 111, 111A

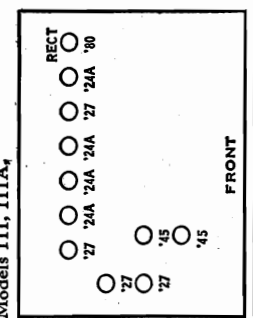

Fig. 3

See Parts List for changes upon Models 111 and 111-A

D-C Resistance Data.	
1st I-F Transformer Primary	68 ohms (25)
2nd I-F Transformer Primary	6.2 ohms (51)
3rd I-F Transformer Primary	95 ohms (37)
Secondary	68 ohms (25)
Secondary	70 ohms (51)
Secondary	65 ohms (37)

PHILCO RADIO & TELEVISION CORP.

MODEL 111, 111-A
Chassis

PHILCO MODELS 111 & 111-A SUPERHETERODYNE

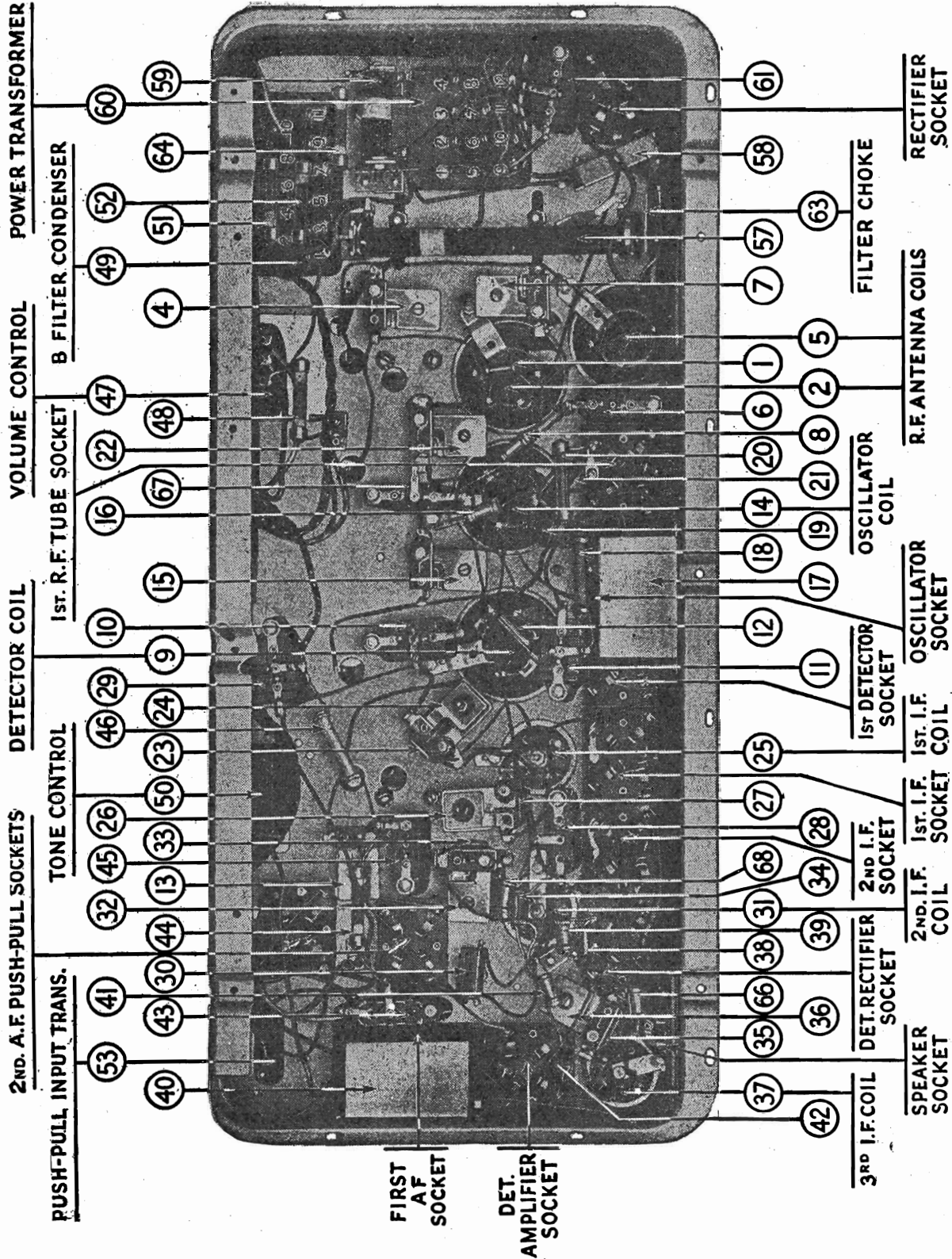

PHILCO RADIO & TELEVISION CORP.

MODEL 112,112-A
Below # 174,001
Parts List

MODELS 112 AND 112-A

This parts list for models 112,112-A is applicable to the phonograph combination models 212,212-A. However, the following changes and additions must be recorded.

Resistor (70) in models 112,112-A is changed to resistor (76) in models 212,212-A. In addition the following are also added to the list in connection with models 212,212-A

70	Motor (50 cycles).....	5333	73	Radio-Phono Switch.....	4514
	Motor (60 cycles).....	4784	74	Cord Connector Plug.....	4091
	Motor (25 cycles).....	4785	75	Cord Connector Socket...	4124
71	Phonograph On-Off Switch	4748		Turn Table.....	4735
72	Pick-up Head.....	4853			

RANGE SWITCH

The Range Switch, No. 30 in Fig. 3, is placed in the NORMAL position when the Receiver is shipped. This gives great distance range and is the setting which will be found most satisfactory in practically all locations. In places far from broadcasting stations, however, the Range Switch may be changed to the MAXIMUM position. This will make the Receiver super-sensitive and will give extreme distance range. Do not use the Range Switch in the MAXIMUM position if there are one or more powerful broadcasting stations near you. In any location there will be less noise between stations with the Range Switch in the NORMAL position.

REPLACEMENT PARTS

No. on Figs. 3 and 4	Description	Part No.	No. on Figs. 3 and 4	Description	Part No.
1	Resistor—10,000 Ohms	4412	40	Condenser—.5	3583
2	1st R. F. Coil	3884-J	41	Resistor—100,000 Ohms	4411
3	Tuning Condenser	4000-D	42	Condenser—.00025	3082
4	Compensating Condenser	3772-A	43	Condenser—.015	3793-B
5	2nd R. F. Coil	3884-T	44	Resistor—500,000 Ohms	3769
6	Condenser—.05	3615-L	45	Condenser—.05	3615-S
7	Compensating Condenser	3968-A	46	Resistor—250,000 Ohms	3768
8	Resistor—100,000 Ohms	4411	47	Volume Control	4093
9	1st Detector Coil	3884-V	48	Resistor—70,000 Ohms	3542
10	Condenser—.05 and 250 Ohms	3615-C	49	B Filter Condenser Block—60 cycles	3754
11	Condenser—.05 and 250 Ohms	3615-C		B Filter Condenser Block—25 cycles	3755
12	Coupling Condenser	3892-A	50	Tone Control	4037-A
13	Compensating Condenser	3968-A	51	Resistor—25,000 Ohms	3656
14	Oscillator Coil	3884-U	52	Resistor—25,000 Ohms	3656
15	Compensating Condenser	3968-A	53	Push-pull Input Transformer	3537
16	Resistor—50,000 Ohms	4518	54	Push-pull Output Transformer	2848
17	Condenser—.25 double	3557	55	Voice Coil and Cone Assembly	2794-B
18	Resistor—13,000 Ohms	3766	56	Field Coil	2850
19	Condenser—.00011	4519	57	B Resistor—10,000 Ohms	4532
20	Resistor—1,000 Ohms	4590	58	C Resistor	3764
21	Condenser—.0007	4520	59	C Resistor—800 Ohms	3763
22	Compensating Condenser	3772-B	60	Power Transformer—60 cycles	4446
23	Condenser—.00011	4519		Power Transformer—25 cycles	4447
24	Compensating Condenser	3772-C	61	Condenser—.015 double	3793-E
25	1st I. F. Coil	4501-B	62	A C Cord and Plug	L-943-A
26	Compensating Condenser	3772-C	63	Filter Choke	3422
27	Condenser—.0001	4519	64	Resistor—70,000 Ohms	3542
28	Condenser—.05	3615-J	65	Pilot Lamp	3463
29	Condenser—.05 and 250 Ohms	3615-B	66	Resistor—100,000 Ohms	4411
30	Range Switch	3116	67	Condenser—.05	3615-D
31	2nd I. F. Coil	4501-C	68	Resistor—100,000 Ohms	4411
32	Compensating Condenser	3772-C	69	On-Off Switch	4095
33	Condenser—.00011	4519	70	Resistor 50,000 Ohms	4518
34	Resistor—500,000 Ohms	4517		Insulator for Part Nos. 3557-3583	4105
35	Condenser—.00005	4587		Pilot Bracket Assembly	4027-A
36	Compensating Condenser	3772-D		Bolt for Pilot Bracket Assembly	W-439
37	3rd I. F. Coil	4501-D		Tone Control Nut	W-434
38	Condenser—.00011	4519		By-pass Condenser Mounting Bolt	W-443
39	Resistor—50,000 Ohms	4518		Bottom Shield Bolt	W-453
				Chassis Mounting Bolt	W-468

MODEL 112,112-A,
Below # 174,001
MODEL 112,112-A
Above # 174,001
Chassis

PHILCO RADIO & TELEVISION CORP.

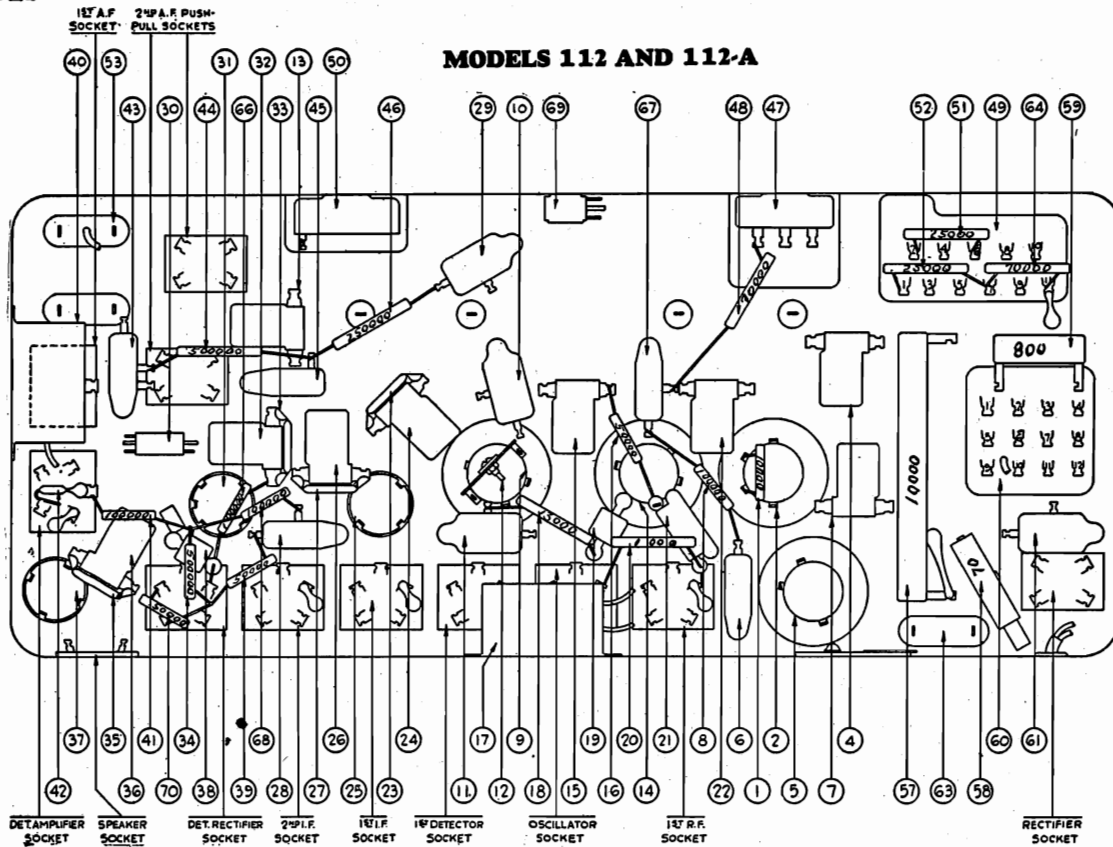

MODELS 112 AND 112-A
(Above Serial No. 174,001)

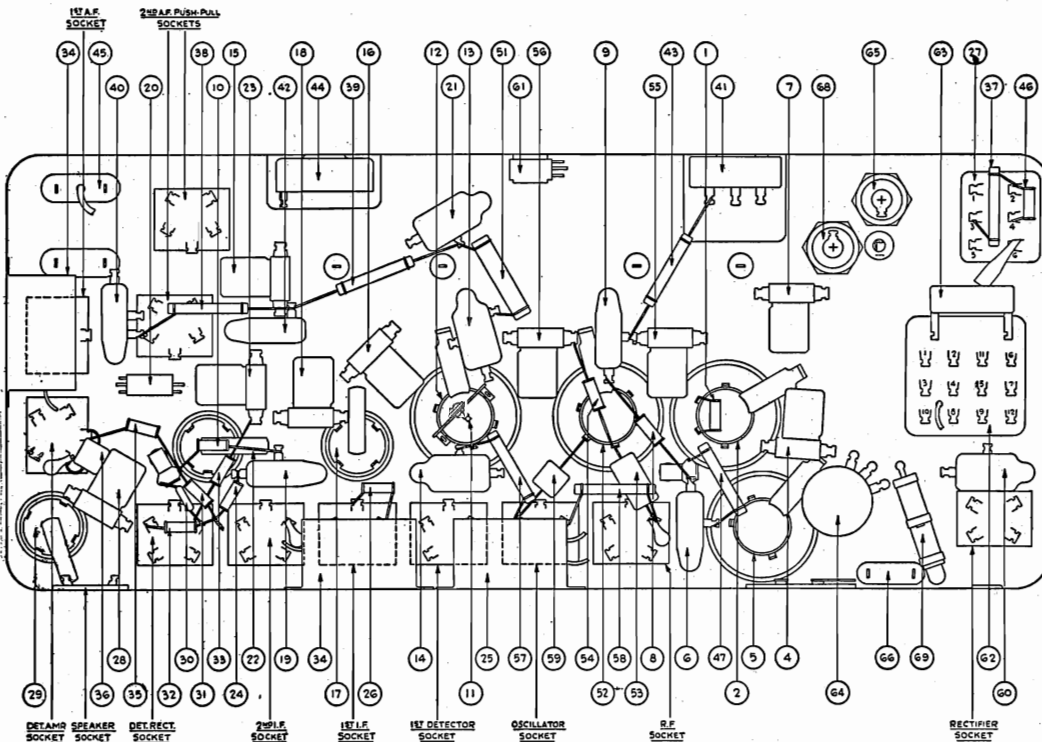

Fig. 4

PHILCO RADIO & TELEVISION CORP.

MODEL 112,112-A
Alignment Notes

PHILCO MODEL 112 SUPERHETERODYNE

Using a Philco fibre wrench, part No. 3164, adjust the third I. F. condenser until the maximum reading is obtained in the output meter. Next, adjust the second I. F. condenser and then the secondary and primary condensers of the first I. F. stage for maximum reading on the meter. During these adjustments it may be necessary to reduce the signal strength by turning down the volume control of the receiver so that the needle will not be deflected beyond the end of the scale.

HIGH FREQUENCY CONDENSER - Remove the "A" terminal lead from the control grid of the first detector tube and replace the grid clip. Replace the tube shield. Connect the "A" terminal of the oscillator to the antenna post of the Receiver and the "G" terminal of the oscillator to the ground terminal of the chassis. Do not change the oscillator setting. Turn up the attenuator of the oscillator until it is all the way on. Set the Philco scale to approximately 140 (1400 K. C.); set the NORMAL - MAXIMUM switch in the Maximum Position provided the Receiver is not too far out of adjustment the eighth harmonic of the 175 note will be heard at or near the 140 position of the scale. Set the station selector knob at exactly 140 and tune the high frequency condenser until the oscillator note is peaked at exactly 140 on the Receiver scale. Next adjust the detector condenser for maximum reading on the output meter.

If the Receiver is so far out of adjustment that the eighth harmonic of 175 K. C. is not audible, it will be necessary to set the oscillator for broadcast frequencies. Set the tuning control of the oscillator at approximately 1400 K. C. (as indicated in the data furnished with the instrument), then adjust the high frequency condenser for maximum signal in the output meter. Set the first and second antenna condensers for maximum signal in the output meter reducing the attenuator setting as the signal increases to prevent damage to the meter mechanism. Turn the center control of the oscillator to intermediate frequency and reset the tuning control of the oscillator to the 175 K. C. position and proceed as outlined above. Final adjustment must be made when the oscillator is set at exactly 175 K. C. in the intermediate position.

ANTENNA CONDENSERS - With the oscillator set at the original 175 K. C. position adjust the first and then the second antenna condenser for maximum reading in the output meter.

LOW FREQUENCY CONDENSER - Set the oscillator on broadcast position and tune to exactly 600 K. C. The oscillator signal should be received at 60 on the Receiver scale. Adjust the low frequency condenser until the maximum reading is obtained in the output meter with the Receiver set at 60.

Where it is necessary to replace the tuning scale on the Model 112 Superheterodyne, put a mark opposite 55 on the tuning condenser drum. Remove the old scale and place the new one in position so that 55 is exactly opposite the above mark.

ADJUSTING THE MODEL 112 SUPERHETERODYNE PLANS USING A
JEWELL 560 OSCILLATOR

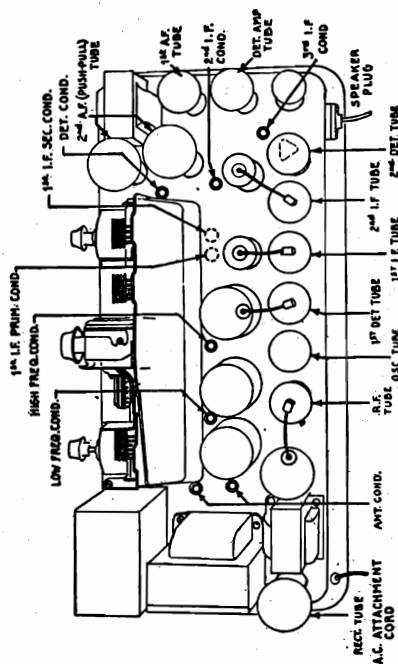

Set up the Receiver for operation using standard tubes, which you know are in good condition. Set the Normal - Maximum switch in the Normal position for the intermediate frequency adjustment. Connect the Jewell pattern 560 oscillator to the Receiver.

INTERMEDIATE FREQUENCY OR I. F. STAGES - Remove the tube shield, replace the control grid clip of the detector tube with the lead from the "A" terminal of the oscillator. The "G" terminal of the oscillator must be connected to the Receiver Chassis. Replace the tube shield on the chassis.

Turn on the filament control of the oscillator about one-half the total movement. The "A" Battery of the oscillator must be replaced when it is necessary to turn this control all the way on in order to obtain a signal. Turn the center switch to the intermediate position. The tuning control of the oscillator must be set so that the oscillator signal is exactly 175 K. C. This setting can be determined from calibration data furnished with the instrument.

Turn the volume control of the receiver on full. Set the attenuator control so that an audible signal is received in the speaker. Connect the \pm and low terminals of the output meter to the voice coils of the speaker. Adjust the attenuator control so that not more than one-half full scale reading is obtained on the meter.

MODEL 112,112-A
Above # 174,001
Electrical Values
Voltage

PHILCO RADIO & TELEVISION CORP.

Models 112 and 112-A Receivers

(Above Serial No. 174,001)

Model 112 Receivers are for operation on 115 volt, 50-60 cycle AC lines
Model 112-A Receivers are for operation on 115 volt, 25-60 cycle AC lines

Table 1—Tube Socket Readings taken with A.C. Set Tester A.C. Line—115 volts

Tube		Filament Volts	Plate Volts	Screen Grid Volts	Control Grid Volts	Cathode Volts	Plate Milli-amperes	Screen-Grid Milli-amperes
Type	Circuit							
24	1st R. F.	2.25	180	75	.2	5.0	4.0	1.
27	Osc.	2.25	556	7.5	1.8	..
24	1st Det.	2.25	180	75	2.5	8.0	.8	1.
24	1st I. F.	2.25	180	75	.2	5.0	4.0	1.
24	2nd I. F.	2.25	180	75	6.*	4.0	4.0	1.
27	Det. Rect.	2.25
27	Det. Amp.	2.25	20	4.0
27	1st A. F.	2.30	150	4.0	3.0	..
47	2nd A. F.	2.30	245	255	16.5	...	31**	9.
47	2nd A. F. Rect.	2.30	245	255	16.5	...	31**	9.
80	Rect.	5.0	54/54	..

*60 Volt scale.

**Special adapter must be used for this test.

Note—Volume control off; station selector turned to low frequency end; range switch set in "Normal" position.

Table 2—Power Transformer Voltages

Terminals	A.C. Volts	
1—2	115.	Primary Heater for 24 and 27 Tubes Not used
3—4	2.67	
6		
5—7	2.68	
10—12	750.	Filaments for 47 Tubes
11		Plates 80 Tube
8—9	5.0	Center Tap 80 Tube
Rubber Covered Lead		Filament 80 Tube
		Center Tap for 24 and 27 Tubes

Table 3—Condenser Data

No. on Figs.	CAPACITY	COLOR
8 9 19 42	.05	Bakelite Container
13 14 21	.05 and 250 Ohms	Bakelite Container
25	.25	Metal Container
30 39	.00011	Blue, Golden Yellow
36	.00025	Yellow
40	.015	Bakelite Container
53	.0007	White, Golden Yellow
60	.015 Double	Bakelite Container
65 68	6 Mfd.	Electrolytic

Table 4—Resistor Data

No. on Figs.	Resistance (Ohms)	Power (Watts)	COLOR		
			Body	Tip	Dot
60	2 Sections 70 ohms ea.		Flat	Wire Wound Tubular	
63	205				
66	1,000	1	Brown	Black	Red
1	10,000	1/2	Brown	Black	Orange
47 67	13,000	1	Brown	Orange	Orange
61	15,000	2	Red	Orange	Black
67	25,000	1	Red	Green	Orange
48	25,000	1/2	Red	Green	Orange
51 52 54	51,000	1/2	Green	Brown	Orange
26	70,000	1/2	Violet	Black	Orange
43	70,000	1	Violet	Black	Orange
8 10 33 35	99,000	1/2	White	White	Orange
28	99,000	1	White	White	Orange
24	490,000	1/2	Yellow	White	Yellow
59	490,000	1	Yellow	White	Yellow

Model 112 Condenser Block Part No. 3754

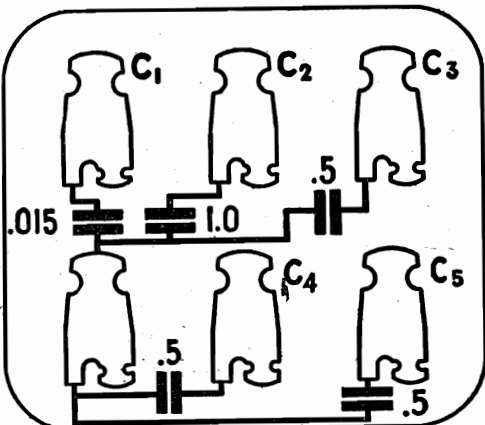

Model 112-A Condenser Block Part No. 3755

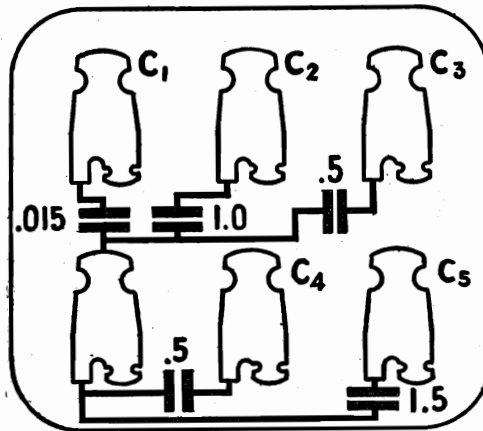

PHILCO RADIO & TELEVISION CORP.

MODEL 470, 470-A
Voltage
Electrical Values

Models 470 and 470-A Receivers

Table 1—Tube Socket Data taken with AC Set Tester—AC Line 115 Volts

Tube		Filament Volts	Plate Volts	Screen Grid Volts	Control Grid Volts	Cathode Volts	Plate Milli-amperes
Type	Circuit						
SHORT WAVE UNIT*							
27	Osc.	2.2	110	...	3.3	0	...
24	Det.	2.2	24	24	5.	0	...
BROADCAST UNIT							
24	R. F.	2.4	255	50	3.5	25	7.5
24	1st. Det.	2.4	260	60	9	38	...
27	Osc.	2.4	60	...	3.5	25	2.
24	I. F.	2.4	265	50	3	22	3.5
24	2nd Det.	2.4	116	40	7	25	...
47	Output	2.5**	205**	220**	.7**	..	28**
80	Rectifier	4.5	260/Plate				

*The voltage readings of the short wave unit were taken from the under side of the chassis, using a Weston multi-range voltmeter, 1000 Ohms per volt. The radio set tester cannot be used, either for voltage or plate current readings because of the effect of the long leads through the set tester cord.

**These readings must likewise be taken from the socket terminals on the under side of the chassis unless the set tester is especially equipped with an adapter for testing pentode tubes.

All the above readings were taken with volume control at maximum.

Table 2—Power Transformer Voltage

Terminals	A. C. Volts	Circuit	Color
SHORT WAVE UNIT			
4-5	105 to 125	Primary	Black
1-3	2.5	Secondary	Yellow
2	...	Center Tap 1-3	Green
BROADCAST UNIT			
1-2	105 to 125	Primary	White (Small Gauge)
3-5	2.5	Filament of 47	Dark Green
6-8	2.5	Filament of 24	Black (Heavy Gauge)
9-10	5.	Filament of 80	Light Blue
11-13	700	Plate of 80	Yellow
4	...	Center Tap of 3-5	Black, Green Tracer
7	...	Center Tap of 6-8	Black, Yellow Tracer
12	...	Center Tap of 11-13	Yellow, Green Tracer

Table 3—Resistor Data

No. on Figs. 1, 2 and 3	Terminal	Power (Watts)	Resistance (Ohms)	Color		
				Body	Tip	Dot
(44)	250	Black Bakelite
(48)	{ 1-2 } { 2-3 } { 4-5 } { 5-6 }	{ 1060 } { 2300 } { 70 } { 240 }	Long Tubular
(29)	1	5,000	Green	Black	Red
(30)5	5,000	Green	Black	Red
(4) (64)	1	13,000	Brown	Orange	Orange
(25) (28)	1	32,000	Orange	Red	Orange
(45)	(50-60 cycles)	.5	45,000	Yellow	Green	Orange
(47) (56)5	51,000	Green	Brown	Orange
(22)	1	99,000	White	White	Orange
(46)5	99,000	White	White	Orange
(9)	1	240,000	Red	Yellow	Yellow
(51) (70)5	240,000	Red	Yellow	Yellow
(19)5	2,000,000	Red	Black	Green

PHILCO RADIO & TELEVISION CORP.

MODEL 470, 470-A
Parts List

Table 4—Condenser Data

Nos. on Fig. 1, 2 and 3	Capacity (Mfd.)	Container	Nos. on Fig. 1, 2 and 3	Capacity (Mfd.)	Container
20	.00011	Blue and Golden Yellow	64	.09 (Double)	Black Bakelite
21	.00025	Yellow	65	.09 (50-60 cycles)	Black Bakelite
48	.00041	Yellow and Orange	77	.18 (25-40 cycles)	Black Bakelite
48	.0005	Green	77	.25	Metal
12	.0008	Green and Orange	52	.5	Metal
10	.00125	Blue and Orange	46	6 (50-60 cycles)	Electrolytic
71	.01	Black Bakelite	75	10 (25-40 cycles)	Electrolytic
72	.015 (Double)	Black Bakelite	78	6 (50-60 cycles)	Electrolytic
2	.05	Black Bakelite	78	10 (25-40 cycles)	Electrolytic

No. on Figs. 1 and 2	Description	Part No.	No. on Figs. 1 and 2	Description	Part No.
1	Oscillator Coil*	03734	45	Resistor (45,000 ohms) 50-60 cycles	5256
2	By-pass Condenser (.05 mfd.)	3615-M	45	Resistor (99,000 ohms) 25-40 cycles	4411
3	Gang Condenser Assembly	03692	46	Condenser (.5 mfd.)	3583
4	Resistor (13,000 ohms)	3766	47	Resistor (51,000 ohms)	4518
5	Compensating Condenser (19 MC End of Top Scale)	04000-E	48	Condenser (500 mmf.)	3910
6	Compensating Condenser (8.5 MC End of Center Scale)	04000-E	49	R. F. Choke	03086
7	Compensating Condenser (3.6 MC End of Bottom Scale)	04000-E	50	Condenser (250 mmf.)	3082
8	Frequency Control Switch	03751	51	Resistor (240,000 ohms)	4410
9	Resistor (240,000 ohms)	3768	52	Condenser (.25 mfd.)	4264
10	Condenser (1,250 mmf.)**	5886	53	Pilot Light (Broadcast Unit)	3463
11	Compensating Condenser (8.5 MC End of Top Scale)**	04000-F	54	Condenser (.09 mfd. double)	4989-C
12	Condenser (800 mmf.)	5878	55	Oscillator Coil	03084
13	Compensating Condenser (3.6 MC End of Center Scale)	04000-F	56	Condenser (410 mmf.)	5120
14	Condenser (250 mmf.)	3082	57	Compensating Condenser—Low Frequency	04000-F
15	Compensating Condenser (1.5 MC End of Bottom Scale)	04000-F	58	Resistor (51,000 ohms)	4518
16	Detector Transformer*	03734	59	Resistor (5,000 ohms)	5310
17	Frequency Filter	03662	60	Compensating Condenser—High Frequency—Part of Gang Condenser Assembly	
18	Antenna Switch Assembled with 22	5796	61	Condenser (.09 mfd. double)	4989-C
19	Resistor (2 megohms) Assembled with 20	03879	62	Condenser (110 mmf.)	4519
20	Condenser (110 mmf.) Assembled with 19	03879	63	B. C. Resistor	03079
21	Condenser (250 mmf.)	3082	64	Resistor (13,000 ohms)	3766
22	Resistor (99,000 ohms)	3767	65	Condenser (.05 mfd.)	3615-L
23	R. F. Choke	03893	66	Voice Coil and Cone Assembly	02996
24	Shielded Cable	L-1278	67	Field Coil Assembled with Pot.	02966
25	Resistor (32,000 ohms)	3525	68	Output Transformer	2673
26	Resistor (32,000 ohms)	3525	69	Tone Control	03140
27	Electrolytic Condenser (6 mfd.)	4916	70	Resistor (240,000 ohms)	4410
28	Pilot Light (Short Wave Unit)	3463	71	Condenser (.01 mfd.)	3903-L
29	Resistor (5,000 ohms)	3526	72	Condenser (.015 mfd. double)	3793-K
30	Plug	03913	73	"On-off" Switch	4095
31	Filament Transformer		74	{ Power Transformer (50-60 cycles)	5117
	{ (50-60 cycles)	5906		{ Power Transformer (25-40 cycles)	5118
	{ (25-40 cycles)	5923		{ Power Transformer (50-60, 230 volts)	5119
	{ (50-60 cycles, 230 volts)	5924	75	Electrolytic Condenser (6 mfd.) 50-60 cycles	4916
32	On-off Switch (Assembled with 18)	5796	76	Electrolytic Condenser (10 mfd.) 25-40 cycles	5142
33	Volume Control	5039	76	Choke	4819
34	First R. F. Transformer	03082	77	{ Condenser (.09 mfd.) 50-60 cycles	4989-J
35	{ Tuning Condenser (50-60 cycles)	03076		{ Condenser (.18 mfd.) 25-40 cycles	4989-K
36	{ Tuning Condenser (25-40 cycles)	03077	78	Electrolytic Condenser (6 mfd.) 50-60 cycles	4916
37	Compensating Condenser — Antenna — Part of Gang Condenser Assembly			Electrolytic Condenser (10 mfd.) 25-40 cycles	5142
38	First Detector Transformer	03083		Line Cord and Plug	L-943
39	Compensating Condenser — Detector — Part of Gang Condenser Assembly			Tube Shield	03987
40	Compensating Condenser — First I. F. Primary	04000-J		Bezel (Broadcast)	5008
41	First I. F. Transformer	03091		Bezel (Short Wave)	5178
42	Compensating Condenser — First I. F. Secondary	04000-H		Knob (Large)	03063
43	Second I. F. Transformer	03092		Knob (Small)	03064
44	Compensating Condenser—Second I. F.	04000-K		Knob (On-Off Switch—Broadcast)	03437
	Resistor (250 ohms Combined with .09 mfd. Condenser)	4989-E		Knob (Control Switch—Short Wave)	5811

*Includes matched oscillator coil and detector transformer.
**These parts replaced on later production by .0018 mfd. condenser, part 6018.

PHILCO RADIO & TELEVISION CORP.

MODEL 490
Schematic
Voltage

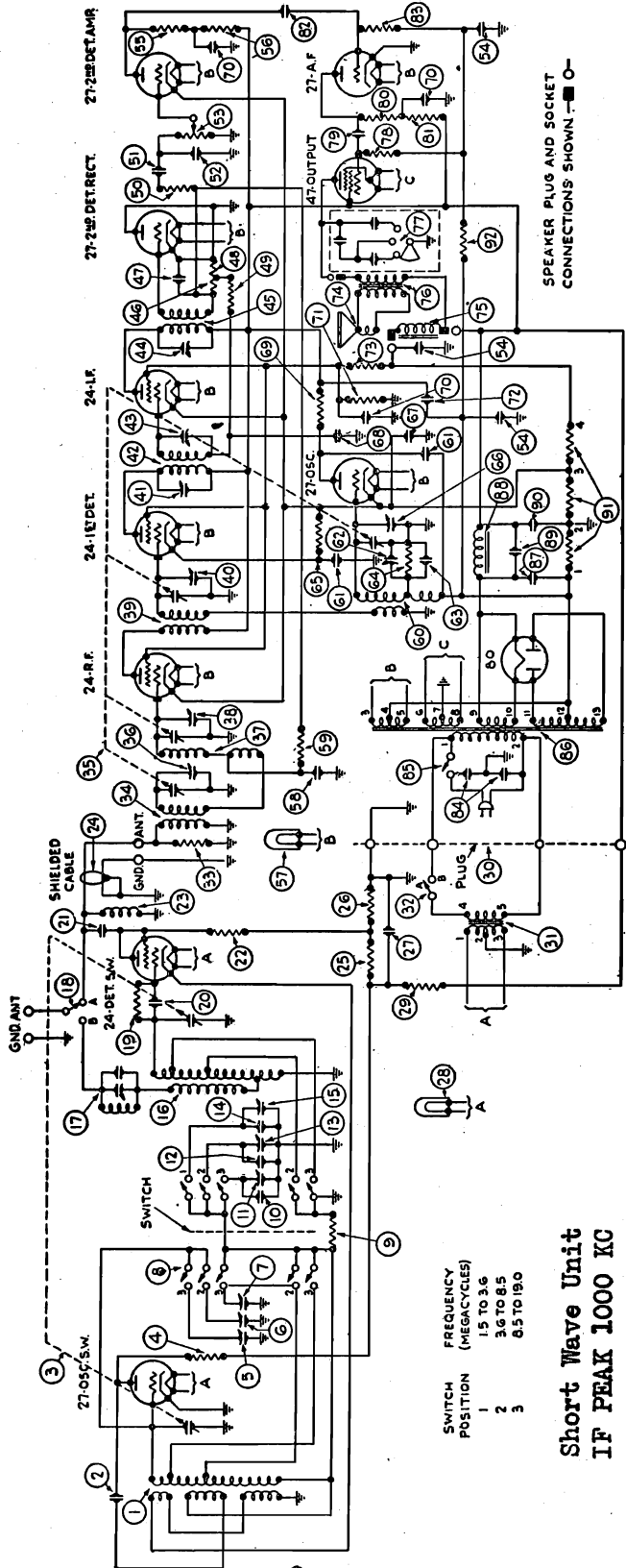

Short Wave Unit
IF PEAK 1000 KC

Broadcast Unit
IF PEAK 175 KC

Model 490 Receiver

Table 1—Tube Socket Readings—Line Voltage 115 volts

Tube	Circuit	Filament Volts	Plate Volts	Screen Grid Volts	Control Grid Volts	Cathode Volts	Plate Milli-amperes
27	Osc.	2.2	110		3.3	0	
24	1st Det.	2.2	24	24	5.	0	
SHORT WAVE UNIT*							
BROADCAST UNIT*							
24	R. F.	2.1	220	50	6.	15	2.
27	Osc.	2.1	80		6	15	2.3
24	1st Det.	2.1	210	55	5	15	0.5
24	I. F.	2.1	220	60	8	15	0
27	Rect. Det.	2.1	150		0	14	1.3
27	Ampl. Det.	2.1	150		2	15	1.5
27	1st Audio	2.1	150		7**	15	28.**
47	Output	2.4**	205**	220**			
80	Rectifier	4.5	220/Plate				

*The voltage readings of the short wave unit were taken from the under side of the chassis, using a Weston Multi-range voltmeter, 1000 ohms per volt. The radio set tester cannot be used, either for voltage or plate current readings because of the effect of the long leads through the set tester cord.
**These readings must likewise be taken from the socket terminals on the under side of the chassis unless the set tester is especially equipped with an adapter for testing pentode tubes.

Model 490 (1932)

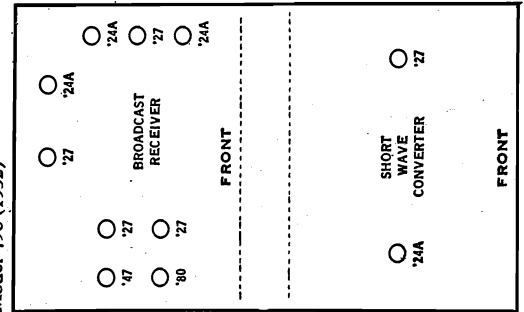

MODEL 490
Chassis
Transformer Data

PHILCO RADIO & TELEVISION CORP.

MODEL 490

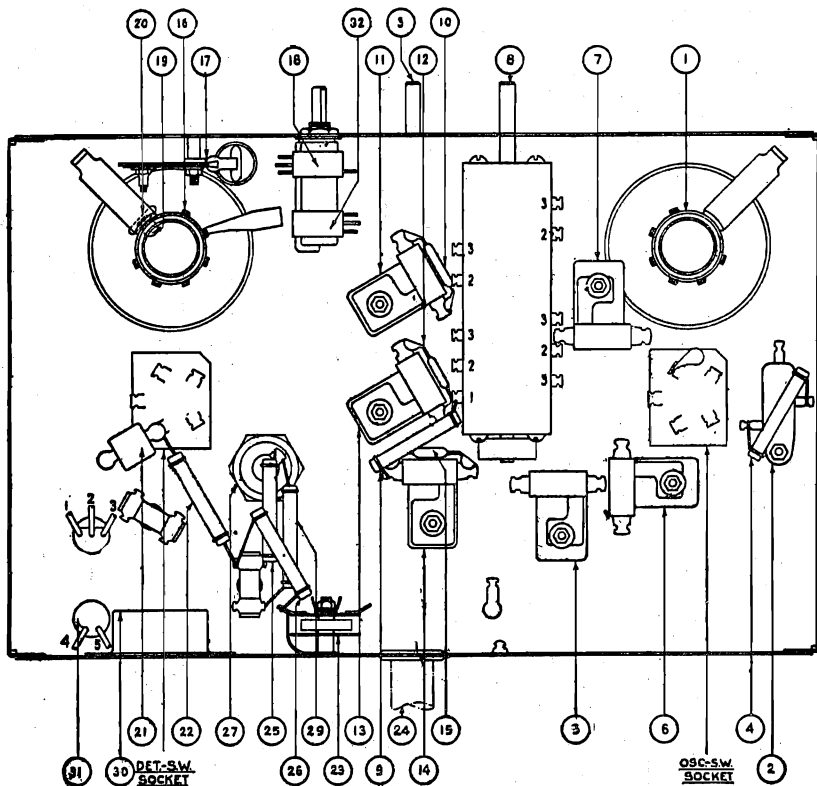

Fig. 2—Short Wave Chassis.

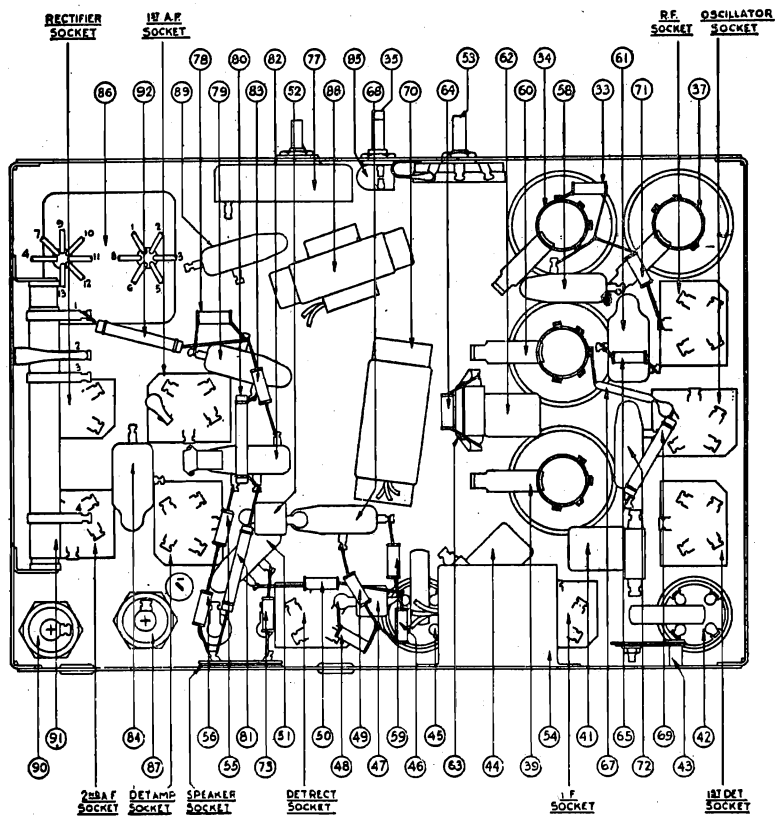

Fig. 3—Broadcast Chassis.

Table 2—Power Transformer Voltages

Terminals	A.C. Volts	Circuit	Color
SHORT WAVE UNIT			
4-5	105 to 125	Primary	Black
1-3	2.5	Secondary	Yellow
2		Center Tap 1-3	Green
BROADCAST UNIT			
1-2	105 to 125	Primary	White
3-5	2.5	Heaters of 24 and 27 Tubes	Black with Yellow
4	2.5	Center Tap of 3-5	Black Green
6-8	2.5	Filament of 47 Tube	Dark Green
7	2.5	Center Tap of 6-8	Black with Green
9-10	5.0	Filament of 80 Tube	Light Blue
11-13	650.	Plates of 80 Tube	Yellow
12	...	Center Tap of 11-13	Yellow with Green

PHILCO RADIO & TELEVISION CORP.

MODEL 490
Electrical Values

No. on Figs. 1 and 2	Description	Part No.	No. on Figs. 1 and 2	Description	Part No.
1	Oscillator Coil*	03734	4519	Condenser (110 mmf.)	4519
2	By-pass Condenser (.05 mfd.)	3615-M	4518	Resistor (51,000 ohms)	4518
3	Gang Condenser Assembly	03692	4517	Resistor (490,000 ohms)	4517
4	Resistor (13,000 ohms)	3766	4411	Resistor (99,000 ohms)	4411
5	Compensating Condenser (19 MC end of Top Scale)	04000-E	3903-R	Condenser (.01 mfd.)	3903-R
6	Compensating Condenser (8.5 MC End of Center Scale)	04000-E	3082	Condenser (250 mmf.)	3082
7	Compensating Condenser (3.6 MC End of Bottom Scale)	04000-E	5366	Volume Control	5366
8	Frequency Control Switch	03751	03325	By-pass Condenser (3-.25 mfd.)	03325
9	Resistor (240,000 ohms)	3768	4518	Resistor (51,000 ohms)	4518
10	Condenser (1,250 mmf.)**	5886	5385	Resistor (70,000 ohms)	5385
11	Compensating Condenser (8.5 MC End of Top Scale)*	04000-F	3463	Pilot Light (Broadcast Unit)	3463
12	Condenser (800 mmf.)	5878	3615-W	Resistor (.05 mfd.)	3615-W
13	Compensating Condenser (3.6 MC End of Center Scale)	04000-F	4517	Resistor (490,000 ohms)	4517
14	Condenser (250 mmf.)	3082	03016	Oscillator Coil	03016
15	Compensating Condenser (1.5 MC End of Bottom Scale)	04000-F	4989-G	Condenser (.09 mfd.)	4989-G
16	Detector Transformer*	03734	04000-B	Compensating Condenser—Low Frequency	04000-B
17	Frequency Filter	03662	4520	Condenser (700 mmf.)	4520
18	Antenna Switch Assembled with 2	5796	4518	Resistor (51,000 ohms)	4518
19	Resistor (2 megohms) Assembled with 2	03879	5310	Resistor (5,000 ohms)	5310
20	Condenser (110 mmf.) Assembled with 2	03879		Compensating Condenser—High Frequency—Part of Gang Condenser Assembly	
21	Condenser (250 mmf.)	3767	4519	Condenser (110 mmf.)	4519
22	Resistor (99,000 ohms)	03893	3615-U	Condenser (.05 mfd.)	3615-U
23	R. F. Choke	L-1278	4237	Resistor (51,000 ohms)	4237
24	Shielded Cable	3525	03327	By-pass Condenser (1, .25, .1) 50-60 cycles	03327
25	Resistor (32,000 ohms)	3525	5385	Condenser (.05 mfd.)	5385
26	Resistor (32,000 ohms)	4916	3615-E	Resistor (25,000 ohms)	3615-E
27	Electrolytic Condenser (6 mfd.)	3463	4516	Resistor (25,000 ohms)	4516
28	Resistor (5,000 ohms)	3526	02996	Voice Coil and Cone Assembly	02996
29	Plug	03913	02966	Speaker Field (Assembly with Pot)	02966
30	Filament Transformer (50-60 cycles) (25-40 cycles)	5806	2673	Output Transformer	2673
31	Resistor (10,000 ohms)	5923	03137	Tone Control	03137
32	On-off Switch (Assembled with 3)	5924	4410	Resistor (240,000 ohms) 50-60 cycles	4410
33	First R. F. Transformer	5796	4411	Resistor (99,000 ohms) 25-40 cycles	4411
34	Gang Condenser Assembly (50-60 cycles)	4412	3903-P	Condenser (.01 mfd.)	3903-P
35	Gang Condenser Assembly (25-40 cycles)	03360	3656	Resistor (25,000 ohms)	3656
36	Compensating Condenser—First R. F.	03001	4237	Resistor (25,000 ohms) 50-60 cycles	4237
37	Part of Gang Condenser Assembly	03078	3903-M	Resistor (50,000 ohms) 25-40 cycles	3903-M
38	Second R. F. Transformer	03014	4410	Condenser (.01 mfd.)	4410
39	Part of Gang Condenser Assembly	03015	3793-E	Condenser (.015 mfd. Double)	3793-E
40	First Detector Transformer	03015	4095	On-off Switch	4095
41	Compensating Condenser—First Detector	04000-J	5362	Power Transformer (50-60 cycles)	5362
42	Compensating Condenser—First I. F.	03009	5363	Power Transformer (25-40 cycles)	5363
43	First I. F. Transformer	04000-J	5364	Power Transformer (50-60 cycles, 230 volts)	5364
44	Compensating Condenser—First I. F.	04000-J	4916	Electrolytic Condenser (6 mfd.) 50-60 cycles	4916
45	Secondary Compensating Condenser—Second I. F.	04000-L	5142	Electrolytic Condenser (10 mfd.) 25-40 cycles	5142
46	Primary Compensating Condenser—Second I. F.	03245	4819	Choke	4819
47	Resistor (51,000 ohms)	4518	4989-J	By-pass Condenser (.09 mfd.) 50-60 cycles	4989-J
			4989-K	By-pass Condenser (.18 mfd.) 25-40 cycles	4989-K
			4916	Electrolytic Condenser (6 mfd.) 50-60 cycles	4916
			5725	Electrolytic Condenser (14 mfd.) 25-40 cycles	5725
			03457	B. C. Resistor	03457
			3768	Resistor (240,000 ohms) 50-60 cycles	3768
			3769	Resistor (490,000 ohms) 25-40 cycles	3769

Condenser Data

Resistor Data

Nos. on Figs. 1, 2 and 3	Capacity Mfd.	Container
①	.00011	Blue and Golden Yellow
②	.00025	Yellow
③	.0007	White and Golden Yellow
④	.0008	Green and Orange
⑤	.00125	Blue and Orange
⑥	.01	Black Bakelite
⑦	.015 Double	Black Bakelite
⑧	.05	Black Bakelite
⑨	.09 (50-60 cycles)	Black Bakelite
⑩	.18 (25-40 cycles)	Black Bakelite
⑪	3-.25 each	Metal
⑫	1, .25, .1 (50-60 cycles)	Metal
⑬	1, .25, .25 (25-40 cycles)	Metal
⑭	6 (50-60 cycles)	Electrolytic
⑮	6 (50-60 cycles)	Electrolytic
⑯	10 (25-40 cycles)	Electrolytic
⑰	14 (25-40 cycles)	Electrolytic
		COLOR

Nos. on Figs. 1, 2 and 3	Terminal	Power (Watts)	Resistance (Ohms)	Body	Tip	Dot
①	{1-2}	..	180		Long Tubular	
②	{2-3}		60			
③	{3-4}		3500			
④		1	5,000	Green	Black	Red
⑤		1/2	5,000	Green	Black	Red
⑥		1	10,000	Brown	Black	Orange
⑦		1	13,000	Brown	Orange	Orange
⑧		1/2	25,000	Red	Green	Orange
⑨		1	25,000	Red	Green	Orange
⑩		1	32,000	Orange	Red	Orange
⑪		1/2	51,000	Green	Brown	Orange
⑫		1	51,000	Green	Brown	Orange
⑬		1/2	70,000	Violet	Black	Orange
⑭		1	99,000	White	White	Orange
⑮		1/2	99,000	White	White	Orange
⑯		1/2	240,000	Red	Yellow	Yellow
⑰		1/2	240,000	Red	Yellow	Yellow
⑱		1/2	490,000	Yellow	White	Yellow
⑲		1/2	490,000	Yellow	White	Yellow
⑳		1/2	2,000,000	Red	Black	Green

*Includes matched oscillator coil and detector transformer.
**These parts replaced on later production by .0018 mfd. condenser, part 6018.

PHILCO RADIO & TELEVISION CORP.

SPECIAL NOTICE*****

Cut up this page and paste the respective chassis layouts upon the pages in the Perpetual Trouble Shooter's Manual which carry the models shown upon this page.

COMPENSATING CONDENSERS

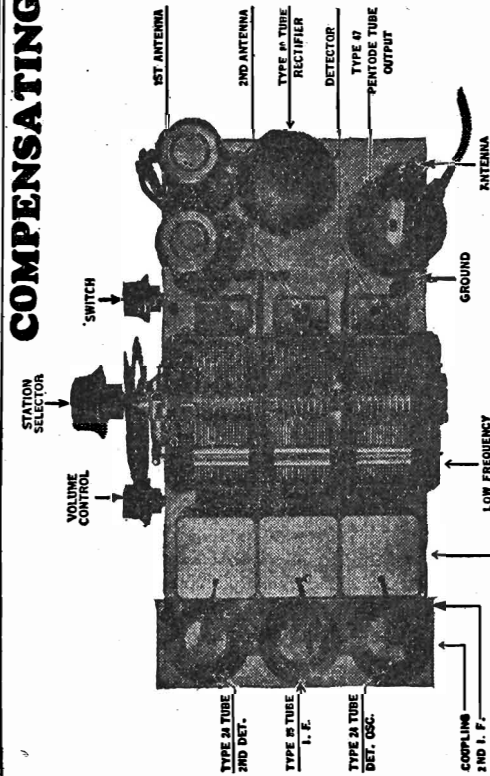

MODELS 51 and 52
Adjust I. F. at 175 K.C.

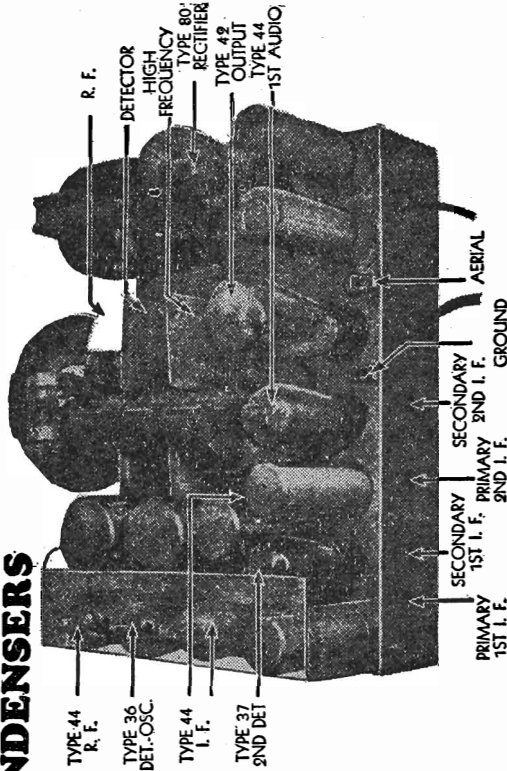

MODEL 71
Adjust I. F. at 260 K.C.

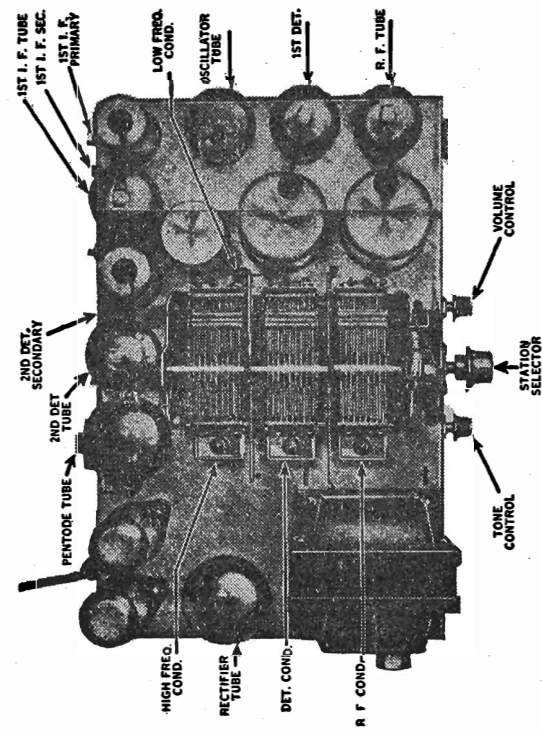

MODEL 70 without Automatic Volume Control,
Adjust I. F. at 260 K.C.

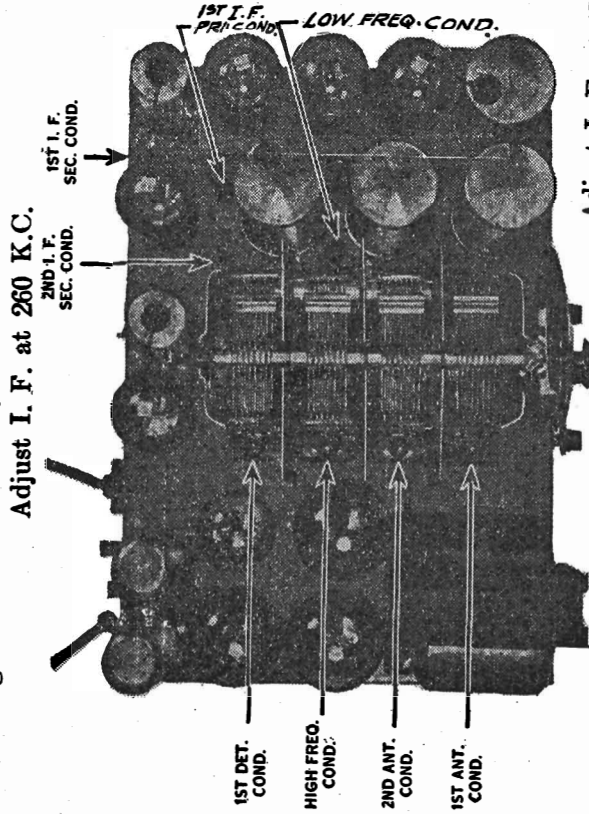

MODEL 90 with Push-Pull 45's Output
Adjust I. F. at 175 K.C.

MODEL 90 with Single Pentode Output--Same Compensating Condenser Locations.

PHILCO RADIO & TELEVISION CORP.

SPECIAL NOTICE*****

Cut up this page and paste the respective chassis layouts upon the pages in the Perpetual Trouble Shooter's Manual which carry the models shown upon this page.

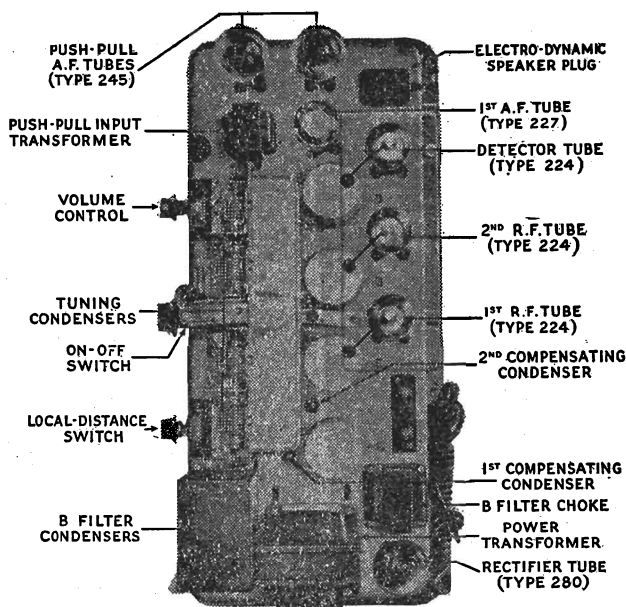
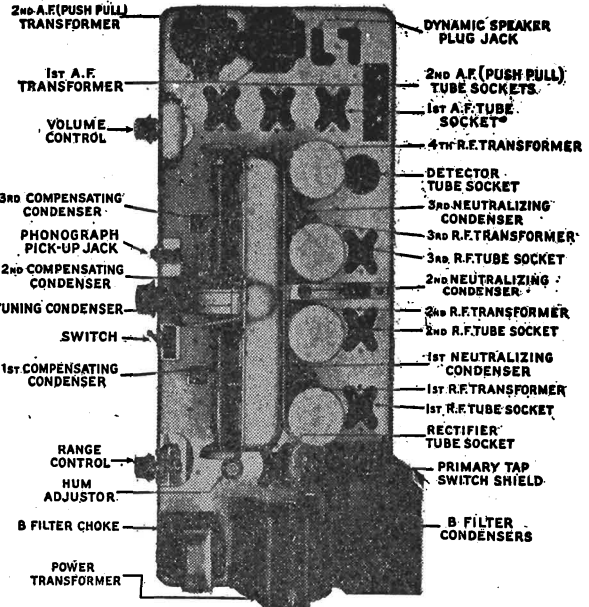

Fig. 1

The Model 76 is for use on 100 to 135 volts, 50 or 60 cycle alternating current.

Model 76



Models 86 and 82

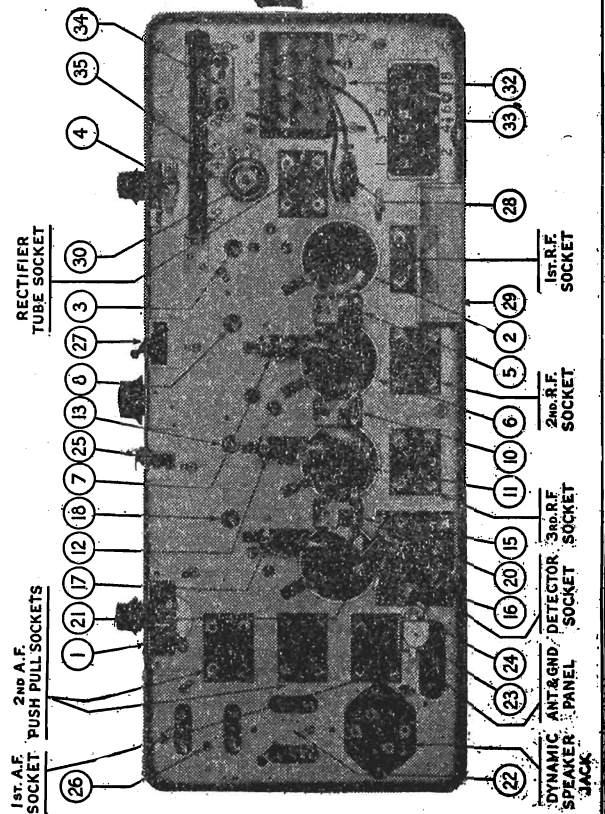
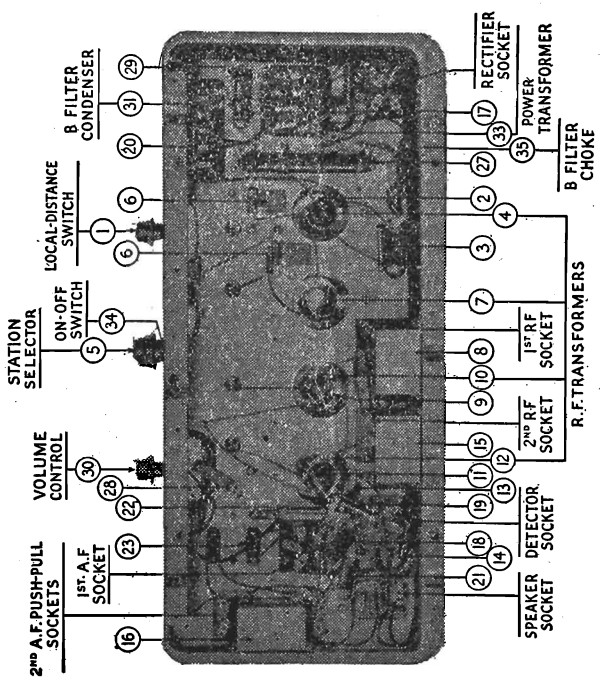

PHILCO RADIO & TELEVISION CORP.

SPECIAL NOTICE *****

Cut up this page and paste the respective chassis layouts upon the pages in the Perpetual Trouble Shooter's Manual which carry the models shown upon this page.

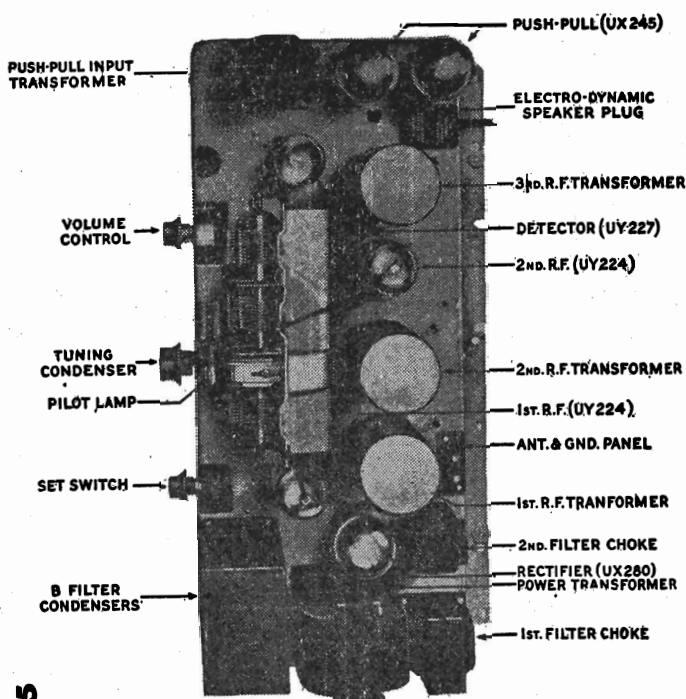
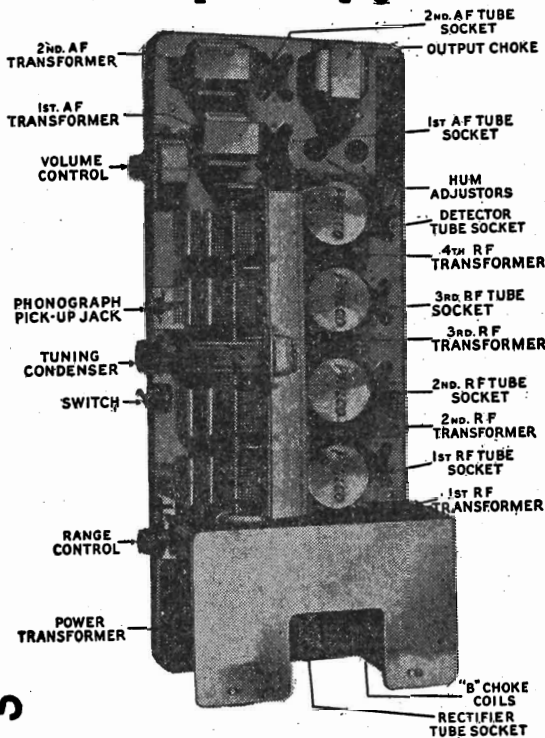

SERIES 5

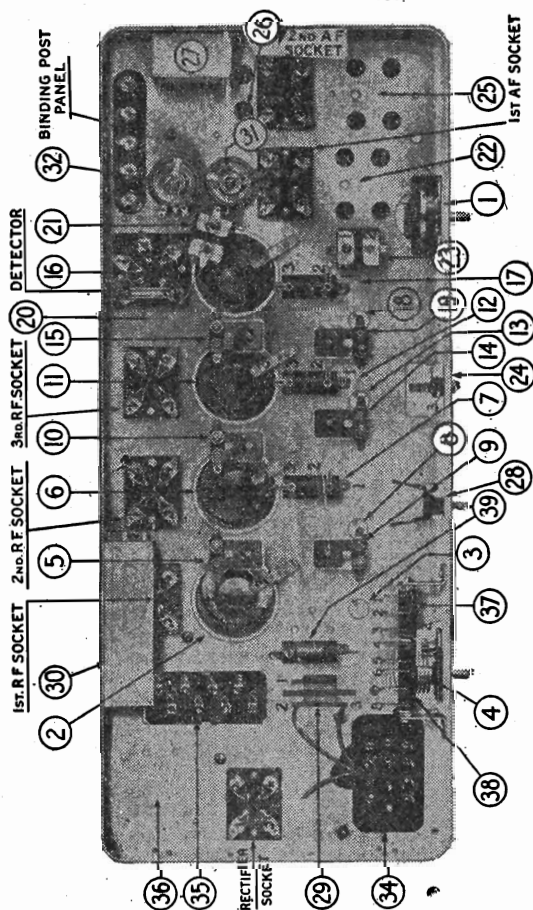

Model 65

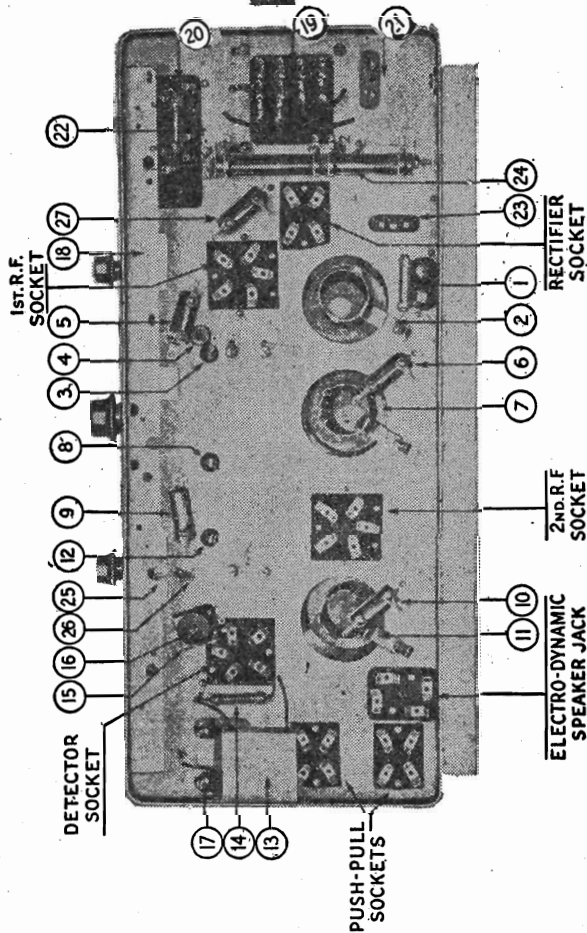

PHILCO RADIO & TELEVISION CORP.

SPECIAL NOTICE*****

Cut up this page and paste the respective chassis layouts upon the pages in the Perpetual Trouble Shooter's Manual which carry the models shown upon this page.

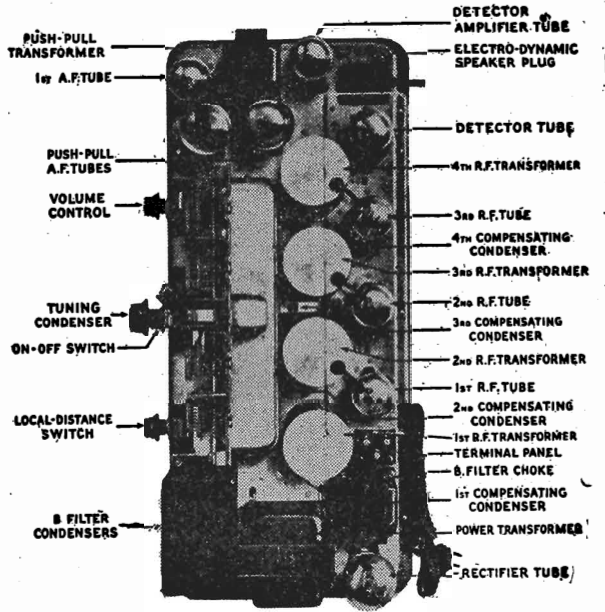
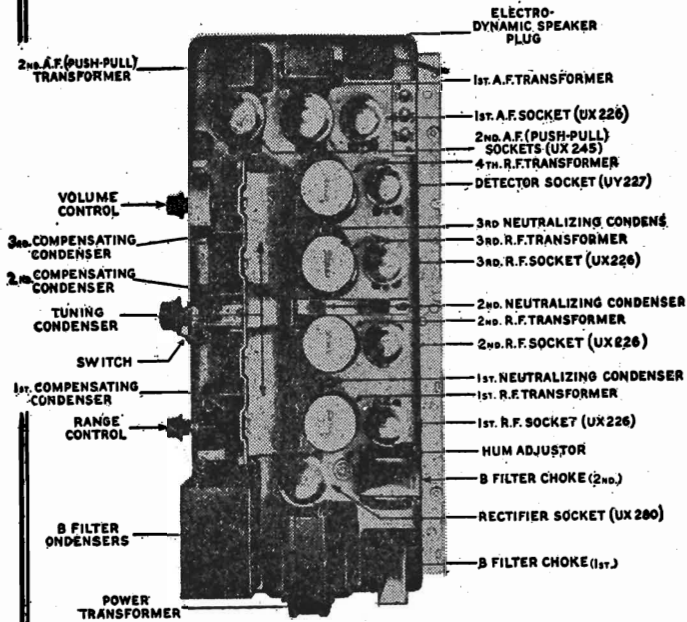

Model 87

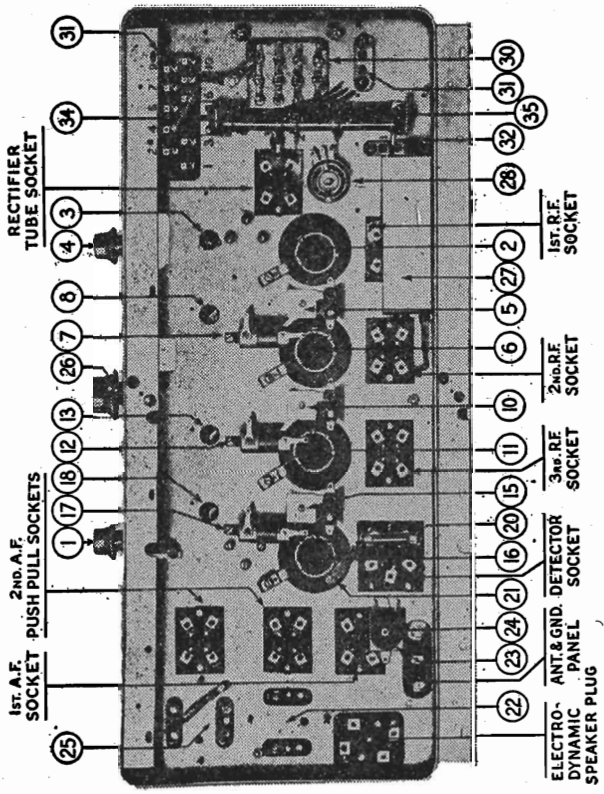

Model 95

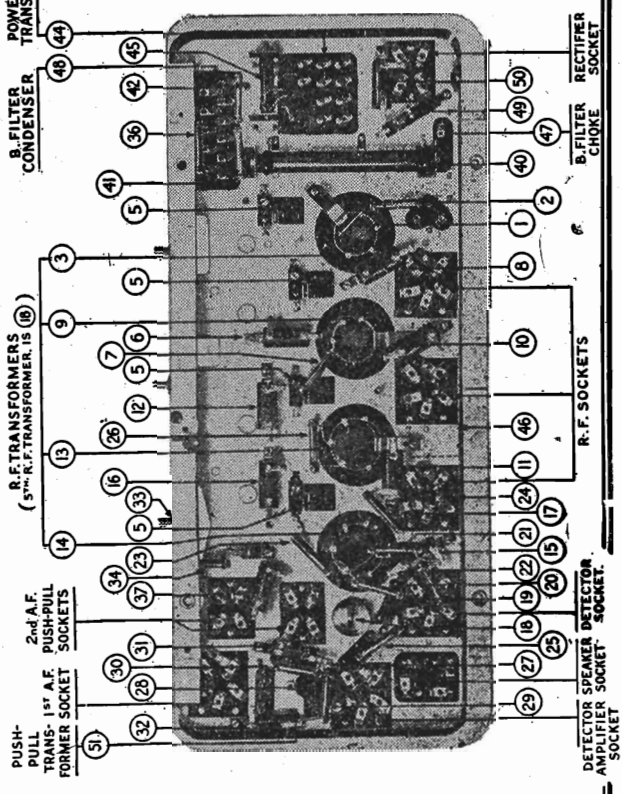

PILOT RADIO & TUBE CORP.

MODEL Dual Wave Midget
 200-2000 meters
 MODEL S-141
 MODEL K-139

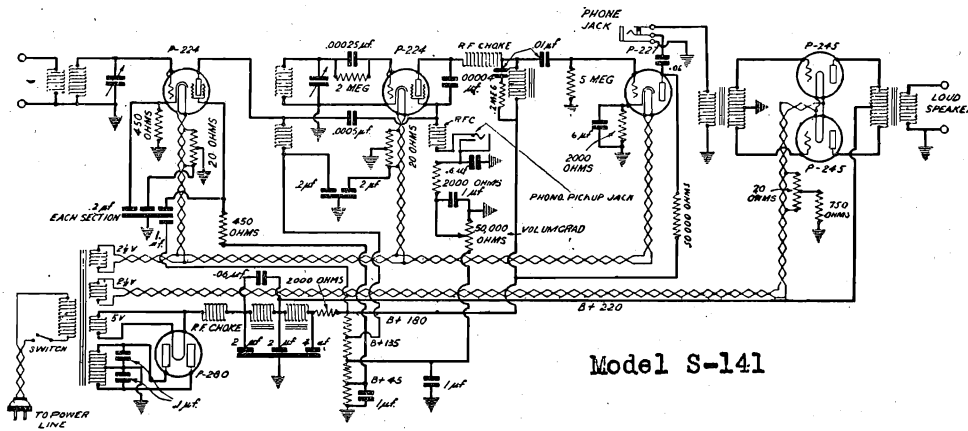

Model S-141

This schematic diagram of the Universal is a functional hook-up, and does not show the actual connections to the cam switches.

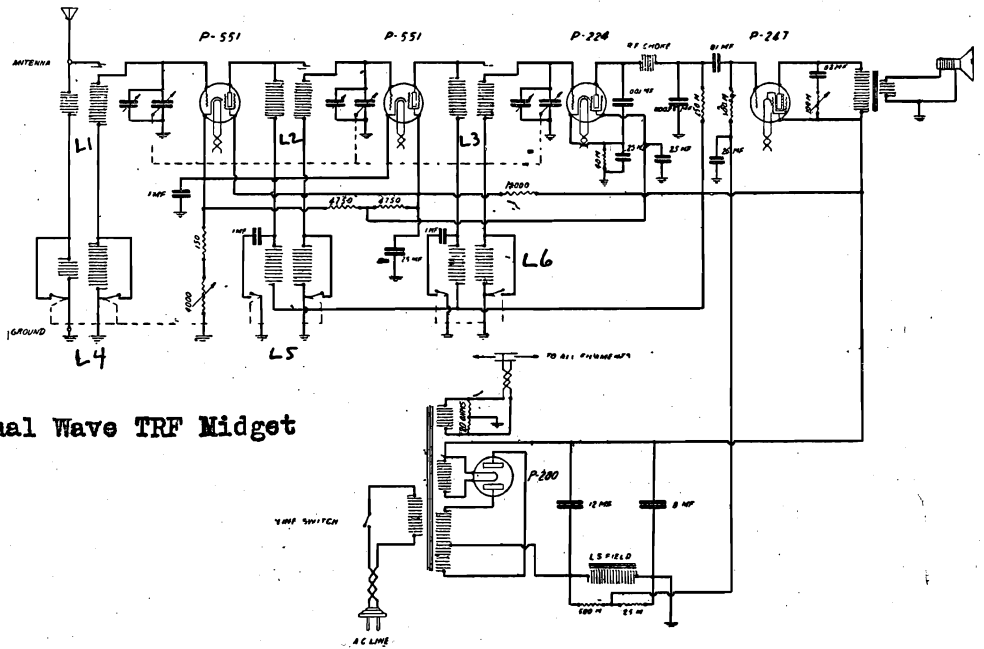

Model Dual Wave TRF Midget

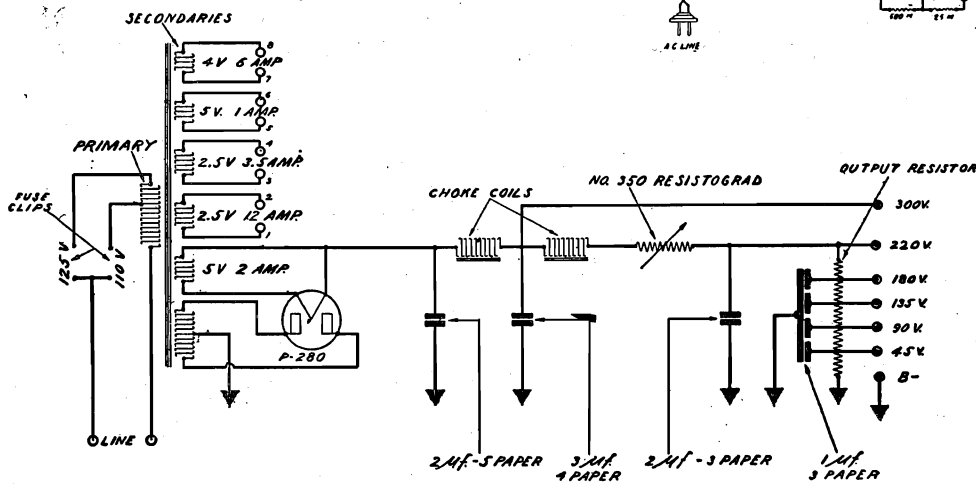

Model K-139 Pack

PILOT RADIO & TUBE CORP.

MODEL C-153, C-154
(With 2-45s)
10 Tube Super

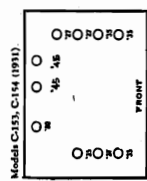
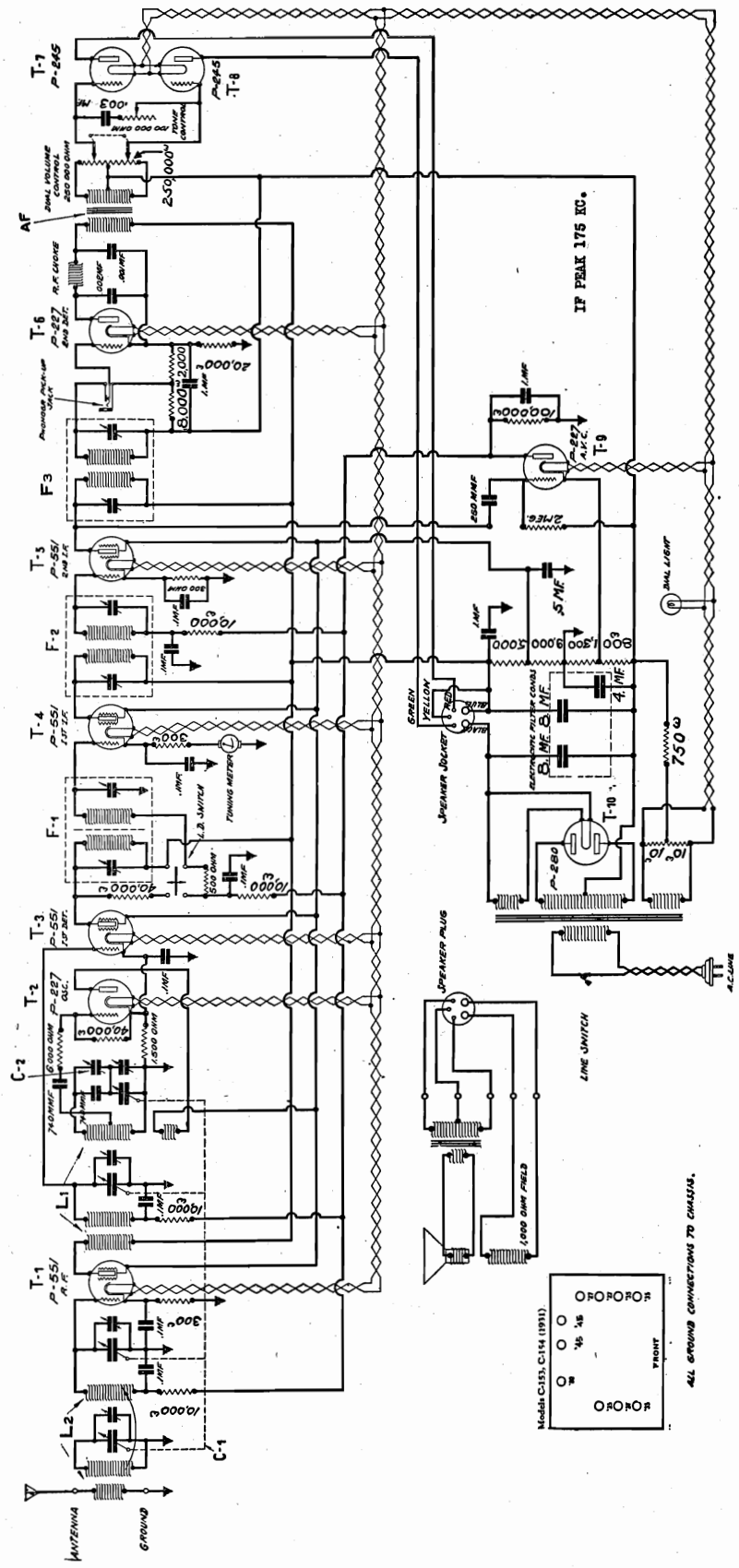

ALL GROUND CONNECTIONS TO CHASSIS.

R. C. A. VICTOR CO., INC.

MODEL R-4, R-6 AC Chassis Voltage

Service work in conjunction with this receiver will be very similar to that of other table type receivers. However, there are several new features of this model which require some consideration.

The second I.F. transformer in this receiver is of the untuned variety, making the set slightly less sensitive and selective than the R-7. This decreased selectivity permits the omission of the 600 K.C. adjustable capacitor used on the R-7, R-10 and other Super-Heterodyne receivers. When aligning adjustments are necessary, it is therefore only necessary to tune one I.F. transformer and the three tuning capacitors. The I.F. transformer is adjusted at 175 K.C. and the tuning capacitors at 1400 K.C. In the case of the latter, the dial should be set at 1400 as well as the oscillator and the three screws adjusted for maximum output. This will permit the dial to read very accurately.

RADIOTRON SOCKET VOLTAGES

120 Volt A. C. Line

VOLUME CONTROL AT MINIMUM

VOLUME CONTROL AT MAXIMUM

Radiotron No.	Cathode to Heater Volts, D. C.	Cathode or Filament to Control Grid Volts, D. C.	Cathode or Filament to Screen Grid Volts, D. C.	Cathode or Filament to Plate Volts, D. C.	Plate Current M. A.	Screen Current M. A.	Heater or Filament Volts, A. C.
1. R. F.	50	50	60	235	0	0	2.66
2. Osc.	50	0	—	55	4.5	—	2.66
3. 1st Det.	10	9	100	260	1.0	0.25	2.66
4. I. F.	50	50	60	235	0	0	2.66
5. 2d Det.	25	10	—	250	1.0	—	2.66
6. Pwr.	—	10	290	280	35	—	2.66

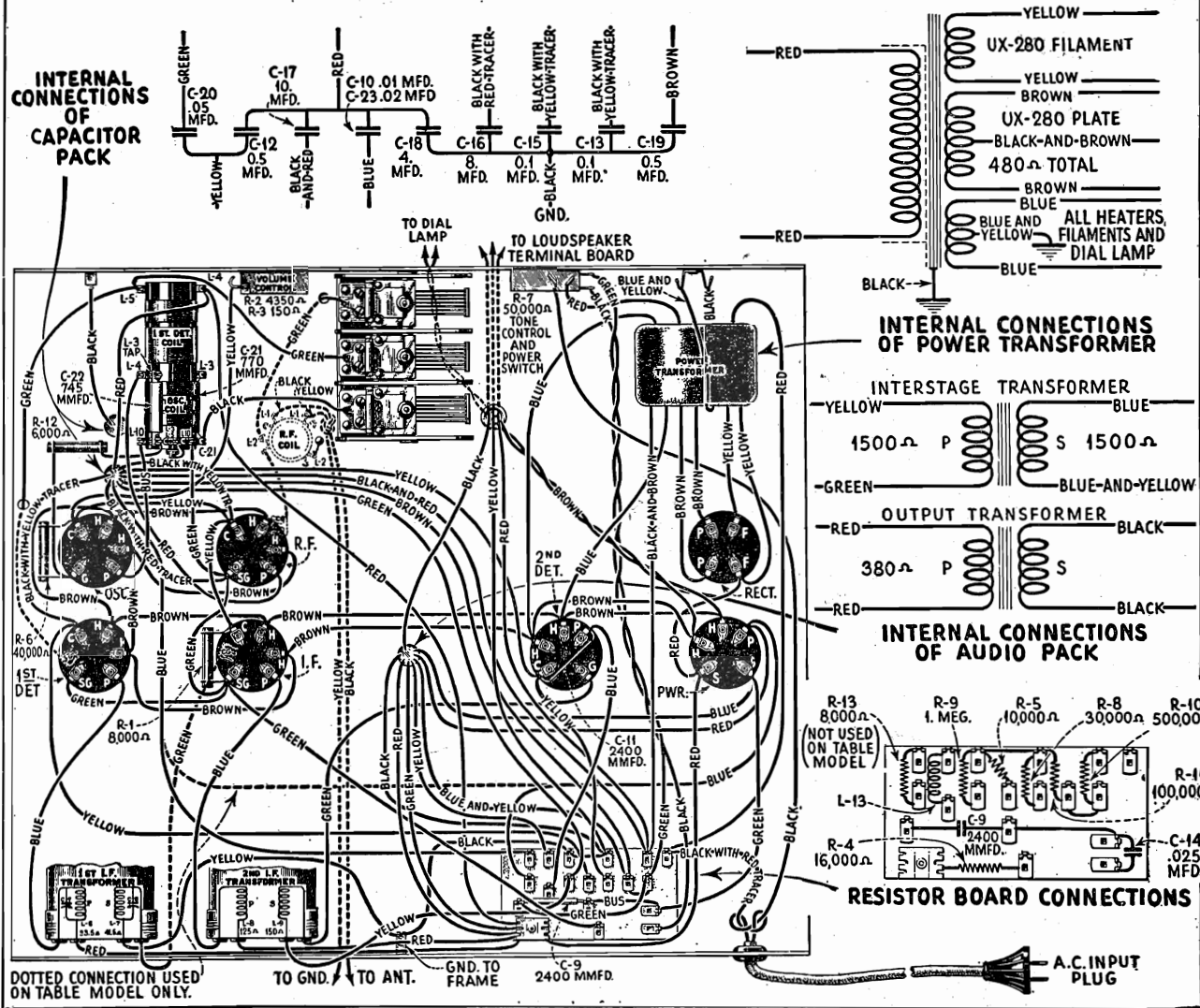
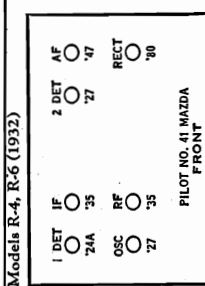

MODEL R-4, R-6 AC
Resistance Test Data

R. C. A. VICTOR CO., INC.

All tubes removed from sockets. AC plug removed from power supply line.
Field coil disconnected. Volume Control maximum unless otherwise stated

From Chassis To	Correct	Incorrect
Aerial to Ground	40 ohms	
Chassis to		
RF Control Grid	1 ohm	TC- rf Cg-Y
RF Cathode (V.C.Min)	4,500 ohms	FC- rf K-Y (8 mfd)
RF Cathode (V.C.Max)	150 ohms	FC- rf K-Y (8 mfd)
RF Screen Grid	8,150 ohms	FC- rf Sg-Y (8 mfd)
RF Plate	24,208 ohms	FC-'80 F-Y (4 mfd) See RF Screen
RF Plate to '80 Fil	58 ohms	
1 Detector Control Grid	4.5 or 5 ohms	TC - 1 D Cg-Y
1 Detector Cathode	10,000 ohms	BC- 1 DK-Y (.1 mfd)
1 Detector Screen	8,150 ohms	See RF Screen
1 Detector Plate	24,243.5 ohms	FC-'80 F-Y (4.mfd) See RF Plate
1 Detector Plate to '80 Fil	93.5 ohms	TC- IF Tr
Oscillator Control Grid	40,150 ohms	Osc Grid Condenser
Oscillator Cathode	150 ohms	BC- Osc K-Y (.1 mfd)
Oscillator Plate	24,151 ohms	See RF Plate
Oscillator Plate - RF Sg	1 ohm	
IF Control Grid	41.5 ohms	TC-IF Cg-Y
IF Cathode	150 ohms	See RF Cathode
IF Plate	24,275 ohms	See RF Plate
IF Plate to '80 Fil	125 ohms	TC- IF Tr
2 Detector Control Grid	1,000,150 ohms	BC- 2 DK-Y (.5 mfd)
2 Detector Cathode	30,000 ohms	BC- 2 DK-'80F (.5 mfd) BC- 2 DK- 2 DP (.0024 mfd)
2 Detector plate	25,730 ohms	BC- 2 DP- 2 DK (.0024 mfd) FC- 80F-Y (4.mfd) FC- rf Sg-Y (8 mfd)
2 Detector Plate to '80 Fil	1,580 ohms	
'47 Control Grid	101,500 ohms	BC- AF Tr-Y (.5 mfd) Tone Control Condenser
'47 Screen Grid	24,150 ohms	See RF Plate
'47 Screen to '80 Fil	0 ohms	
'47 Plate	4,530 ohms	BC Across AF Tr in R 4, Harmonic condenser
'47 Plate to 80 Fil	380 ohms	
'80 Anode	600,240 ohms	
'80 Anode to 80 Anode	480 ohms	
'80 Fil to '80 Anode	624,390 ohms	FC- 80 Fil (10 mfd)
Across field coil only	1,900 ohms	
Across oscillator winding only	6 ohms	

R. C. A. VICTOR CO., INC.

MODEL R-5
Resistance Data
MODEL R-5-X
Resistance Data

Model R-6

All tubes removed from receiver and AC plug disconnected from power supply line - Red and Yellow speaker field leads disconnected

From Chassis To	Correct	Incorrect
Aerial (V.C.Max)	20,000 ohms	Antenna BLC
RF Control Grid	5.3 ohms	TC-Y
RF Cathode	600 ohms	BC-Y
RF Screen Grid	13,000 ohms	BC-Y
		BC-rf Sg - r f K
		BC-D Sg - D K
RF Plate - '80 F	91 ohms	
RF Plate	33,091 ohms	BC-rf P-rf K
		FC-Y (2. mfd)
Detector Control Grid	5.5 ohms	TC-Y
Detector Cathode	28,000 ohms	BC-Y
Detector Screen Grid	21,000 ohms	BC-D Sg - D K
Detector Plate	328,080 ohms	BC-Y (.25 mfd) .45000ohms
		FC-Y, (2. mfd)
		BLC-47 Cg
		BC-DK (.00032 mfd)
Detector Plate - '80 Fil	295,080 ohms	See Detector Plate
'47 Control Grid	560,000 ohms	BC-Y (.5 mfd)
'47 Screen Grid	33,000 ohms	FC-Y (2. mfd)
'47 Plate	33,350 ohms	See '47 Sg
'47 Plate to '80 Fil	350 ohms	
'80 Plate to Plate	330,240 ohms	FC- (10 mfd)
'80 Plate to Plate	480 ohms	
AC Plug	0 ohms	BC-Y (.05 mfd)
Across AC Plug	9 ohms	
Across Speaker Field	2,000 ohms	
Input RF Transf Prim	41 ohms	



110-VOLT LINE

These are readings obtained with the usual Set Analyzers and are not true readings of the voltages at which the Radiotrons operate.

Radiotron No.	Heater to Cathode Volts	Cathode or Filament to Control Grid Volts	Cathode or Filament to Plate Volts	Plate Current M. A	Heater Volts
1	3.0	3.0	85	4.0	2.2
2	7.0	7.0	65	0.25	2.2
3	—	2.0	225	30.0	2.2

Model R-5-X

All tubes removed and AC plug disconnected - Speaker field red and yellow leads opened

From Chassis To	Correct	Incorrect
Aerial (V.C.Max)	20,000 ohms	Antenna BLC
RF Control Grid	5.3 ohms	TC-Y
RF Cathode	600 ohms	BC-Y
RF Screen Grid	13,000 ohms	BC-Y
		BC-rf Sg - rf K
		BC-D Sg - D K
RF Plate	33,091 ohms	FC - Y (2 mfd)
RF Plate - '80 F	91 ohms	
Detector Control Grid	5.5 ohms	TC-Y
Detector Cathode (Reg. Max)	12,000 ohms	BC-Y
Detector Cathode (Reg. Min)	40,000 ohms	
Detector Plate	328,080 ohms	BC-Y (.25mfd-45000 ohm)
		FC-Y (2. mfd)
		BLC-47 Cg
		BC-DK 1.00032 mfd
Detector Plate - '80 Fil	295,080 ohms	See Detector Plate
'47 Control Grid	560,000 ohms	BC-Y (.5 mfd)
'47 Screen Grid	33,000 ohms	FC-Y (2. mfd)
'47 Plate	33,350 ohms	See '47 Sg
'47 Plate - '80 Fil	350 ohms	
'80 Plate to Plate	330,240 ohms	FC- (10 ,mfd)
'80 Plate to Plate	480 ohms	
AC Plug	0 ohms	BC-Y (.05 mfd)
Across AC Plug	9 ohms	
Across Speaker field	2,000 ohms	
Across Input RF Transformer Primary	41 ohms	

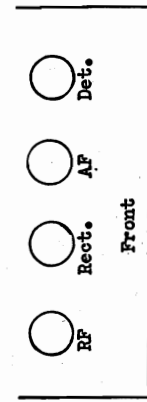

110-VOLT LINE

These are readings obtained with the usual Set Analyzers and are not true readings of the voltages at which the Radiotrons operate.

Radiotron No.	Heater to Cathode Volts	Cathode or Filament to Control Grid Volts	Cathode or Filament to Plate Volts	Plate Current M. A.	Heater Volts
1	3.0	3.0	85	4.0	2.2
2	7.0	7.0	65	0.25	2.2
3	—	2.0	225	30.0	2.2

MODEL R-5-X
Parts List
Notes

R. C. A. VICTOR CO., INC.

Model R-5-X

Models R-5, R-5X (1931)

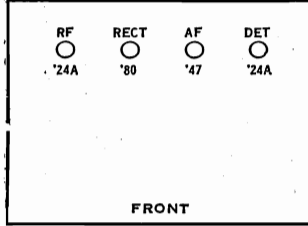

The antenna and ground are connected to each side of a 20,000 Ohm potentiometer. The moving contact of the potentiometer is connected to the primary of the first R.F. transformer through a .00013 MFD. condenser, the other side of the transformer being connected to ground. The action of the potentiometer, reducing the voltage applied to the grid of the first R.F. tube, constitutes that of a volume control. The secondary of the R.F. transformer is connected to the grid circuit of the R.F. Radiotron UY-221, which is tuned by one unit of the gang condenser. The plate circuit of this tube works into the primary coil of the 2nd R.F. transformer.

The detector is of the regenerative, grid bias type and its output is coupled by means of resistance coupling to the output Radiotron RCA-247. The regenerative feature of the detector is un-

usual in that it uses two regeneration coils. One of these resonates at a low frequency and improves the sensitivity at that end, while the other has but few turns and brings up the sensitivity at the high frequency end.

The output stage uses the RCA-247 Output Pentode which gives a high undistorted output—2.5 watts—together with a high gain in the stage.

The grid bias for this tube is obtained by using a portion of the drop across the reproducer field. Due to the fact that the plate current of the RCA-247 represents the greatest portion of the total plate current, using the drop across the field acts as a semi-self biasing arrangement.

Plate and grid supply to all tubes is supplied through the use of Radiotron UX-280. The filter is of the "brute force" type. The reproducer unit field coil functions as the reactor. One electrolytic 10 MFD. capacitor and one paper 2 MFD. capacitor act as filter capacitors

LINE-UP CAPACITOR ADJUSTMENTS

Two adjustable capacitors are provided for aligning the two tuned circuits at the high frequency end of the scale. The following procedure may be used for making any readjustments that may be necessary.

A. Procure an Oscillator giving a modulated signal at exactly 1400 K.C. Also procure a special socket wrench such as RCA Victor Stock No. 3007.

B. An output indicator is necessary. This may be a current squared thermogalvanometer connected to the secondary of the output transformer in place of the cone coil or other types of output indicators.

C. Turn the station selector until the knob reads exactly 0. Then remove the chassis from the cabinet being careful not to disturb the setting of the dial. The gang condenser rotor plates should be fully meshed with the stator plates. If not, then the dial drum must be adjusted until such a condition exists. Replace the chassis in the cabinet.

D. Place the oscillator in operation at exactly 1400 K.C. and couple its output to the antenna lead. Set the dial scale at 85 and place the Radiolite in operation. Place a soft pad on the bench and turn the instrument on its side. Now with the special wrench, adjust each line-up capacitor until maximum output is obtained in the output meter. Be careful to adjust the volume control or oscillator output so that an excessive reading is not obtained. Go over each adjustment a second time to compensate for any interlocking of adjustments.

REPLACEMENT PARTS

Part No.	DESCRIPTION	List Price	Part No.	DESCRIPTION	List Price
2549	Resistor 250,000 Ohms—Carbon type—Package of 5.	\$3.00	3066	Resistor—12,000 Ohms—Carbon type—Package of 5.	\$2.50
2747	Cap - Control grid contactor cap - Package of 5.	.50	3067	Variable Resistor - Regeneration Control Variable Resistor complete with mounting washer and nut.	1.50
2954	Capacitor - By-pass capacitor pack containing three 0.1 Mfd. capacitors.	.75	5817	Resistor—20,000 Ohms—Carbon type.	.90
2955	Transformer—First R.F. transformer complete with mounting washer and nut.	1.50	7054	Cord—Power cord complete with male connector plug	1.00
2956	Transformer—Second R.F. transformer complete with mounting washer and nut.	2.00	7229	Socket—Five prong Radiotron socket complete with insulating shield 3 used—Package of 2.	.50
2957	Capacitor 10 Mfd. electrolytic type Complete with terminal, insulating washer, mounting nut and lock washer.	3.00	7230	Socket—Four prong Radiotron socket complete with insulating shield—1 used—Package of 2.	.50
3069	Switch Operating switch complete.	.60	7231	Capacitor—Filter and by-pass capacitor pack—Comprising one 0.05 mfd., two 0.5 mfd., two 0.25 mfd. and one 2.0 mfd. condensers.	2.50
2959	Volume control 20,000 Ohm Volume control complete with mounting washers and nut.	1.50	7232	Capacitor—2 gang variable tuning capacitor.	5.00
2960	Dial—Dial scale complete with set screws—Package of 2	.50	7234	Transformer—Output transformer—With fibre terminal board.	1.50
2961	Coil Detector plate R.F. choke coil.	.50	7236	Cone—Reproducer cone complete with voice coil and paper ring.	1.50
2962	Capacitor 0.005 Mfd. audio coupling capacitor.	.75	8669	Transformer—Power transformer—105-125 volt, 50-60 cycle—Complete with mounting washers and nuts.	6.00
2963	Resistor 8000 Ohms Carbon type—Package of 5.	2.50	8670	Transformer—Power transformer—105-125 volt, 25-40 cycle—Complete with mounting washers and nuts.	9.00
2964	Resistor 13000 Ohms Carbon type—Package of 5.	2.50	8671	Transformer—Power transformer—220 volts, 50-60 cycles—Complete with mounting washers and nuts.	8.00
2965	Resistor 600 Ohms—Carbon type—Package of 5.	2.50	10134	Resistor—Mil-tapped filament resistor—Used on early models only.	.50
2967	Resistor 45,000 Ohms Carbon type—Package of 5.	2.50	SPECIAL PARTS SUPPLIED ON ORDER ONLY (Not to be stocked)		
2969	Resistor 50,000 Ohms Carbon type—Package of 5.	2.50	2979	Board—Baffle board complete with grille cloth.	.75
2970	Resistor 500,000 Ohms Carbon type—Package of 5.	2.50	2980	Escutcheon—Station selector escutcheon complete with mounting screws.	.75
2971	Resistor 280,000 Ohms Carbon type—Package of 5.	2.50	3058	Board—Resistor mounting board—Less all resistors, capacitors and coils.	1.00
2972	Shield Radiotron shield complete with mounting screws, washer and nut.	.50	7235	Coil—Field coil complete with bracket and cone ring.	2.00
2975	Rivet Eyelet rivet for mounting cone—Package of 100	.50	9321	Cabinet—Cabinet complete—Less all equipment.	7.25
2976	Knob Volume control or Regeneration control knob—Package of 5.	1.50	9339	Chassis—Receiver chassis complete—Less reproducer unit, knobs and Radiotrons.	27.50
2977	Knob Station selector knob—Package of 5.	2.50	9340	Reproducer unit—Reproducer unit complete.	4.75
2978	Screw assembly: Loudspeaker mounting screw assembly comprising four screws, four washers, four lock washers, eight nuts and four eyelets.	.60			
2981	Capacitor—320 Mmfd. detector plate R.F. by-pass capacitor.	.50			
3006	Capacitor .001 Mfd. Used across low frequency tickler coil.	.50			
3007	Wrench Special wrench for R.F. line-up condenser adjustments.	1.00			

R. C. A. VICTOR CO., INC.

MODEL R-7, R-9 AC
Superette
Resistance Data

All tubes removed from receiver and AC plug disconnected from power supply socket. Speaker field disconnected. Volume control adjusted to maximum, unless otherwise stated

Output Tube Control Grid
Output Tube Grid to Grid
Output Tube Plate (2 tubes)
Output Tube Plate to Plate
'80 Filament to Anode
'80 Anode to Anode
'80 Anode to Chassis
Across Speaker field

Correct
40 ohms
5 ohms
3,950 ohms
150 ohms
8,150 ohms
22,508 ohms

Incorrect

From Chassis To
Aerial to Ground
Chassis (Y) to
RF Control Grid
RF Cathode (V.E.Mln)
RF Cathode (V.C.Max)
RF Screen Grid
RF Plate
1 Detector Control Grid
1 Detector Cathode
1 Detector Screen Grid
1 Detector Plate
1 Detector Plate-'80 F
Oscillator Control Grid
Oscillator Cathode
Oscillator Plate
Osc. Plate-1 Det Screen
IF Control Grid
IF Cathode
IF Screen Grid
IF Plate
IF Plate-'80 Fil
2 Detector Control Grid
2 Detector Control Grid-Ter 2
2 Detector Cathode
2 Detector Plate
2 Det Plate-'80 F

TC-Y
BC-Y
See Min. Adj.
BC-rf Sg-Y
FC-Y (4.mfd)
BC-'90 F-Y (.5 mfd)
TC-Y
BC-1 D K-Y
See R-F Sg
See R-F Plate
TC-1 IF Tr
TC-1 IF Tr
Osc. Grid Cond.
See R-F Cathode
See R-F Cathode
See R-F Screen
TC-Y
See R-F Cathode
See R-F Screen Grid
See R-F Plate
BC-if P = 2 DK
TC-2 IF Tr
TC-2 IF Tr

10,000 ohms
8,150 ohms
22,543.5 ohms
93.5 ohms
40,150 ohms
150 ohms
8,151 ohms
1 ohm
41.5 ohms
150 ohms
8,150 ohms
22,491 ohms
41.5 ohms
1,000,093.5 ohms
93.5 ohms
30,000 ohms
23,250 ohms
800 ohms

Volume Control Maximum
Tube Cathode- Grid
Heater
RF
Osc.
1Det
IF
2Det
AF
AF

Cathode- Plate
Screen
Cathode- Plate
Current
4.0 ma
55
215
225
200
215
215

Plate
225
55
215
225
200
215
215

Cathode- Plate
225
55
215
225
200
215
215

Current
4.0 ma
55
215
225
200
215
215

Fil.
2.4
2.4
2.4
2.4
2.4
2.4
2.4

* Not true reading because of resistance in circuit.

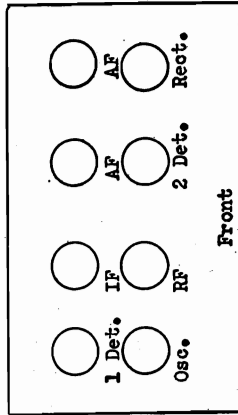

Magnetic Pickup Terminal Board 1-2 Closed

BC-#2 Ter.- 2DK
TC- #1 Terminal
BC- 2 D K- if P
BC- 2 DP = 2 D K
BC- 2 DP = 2 D K
FC-'80 F-Y (.5 mfd)
FC-'80 F-Y (4. mfd)
See R-F Plate

R. C. A. VICTOR CO., INC.

MODEL R-7, R-9 DC
Superette
Chassis

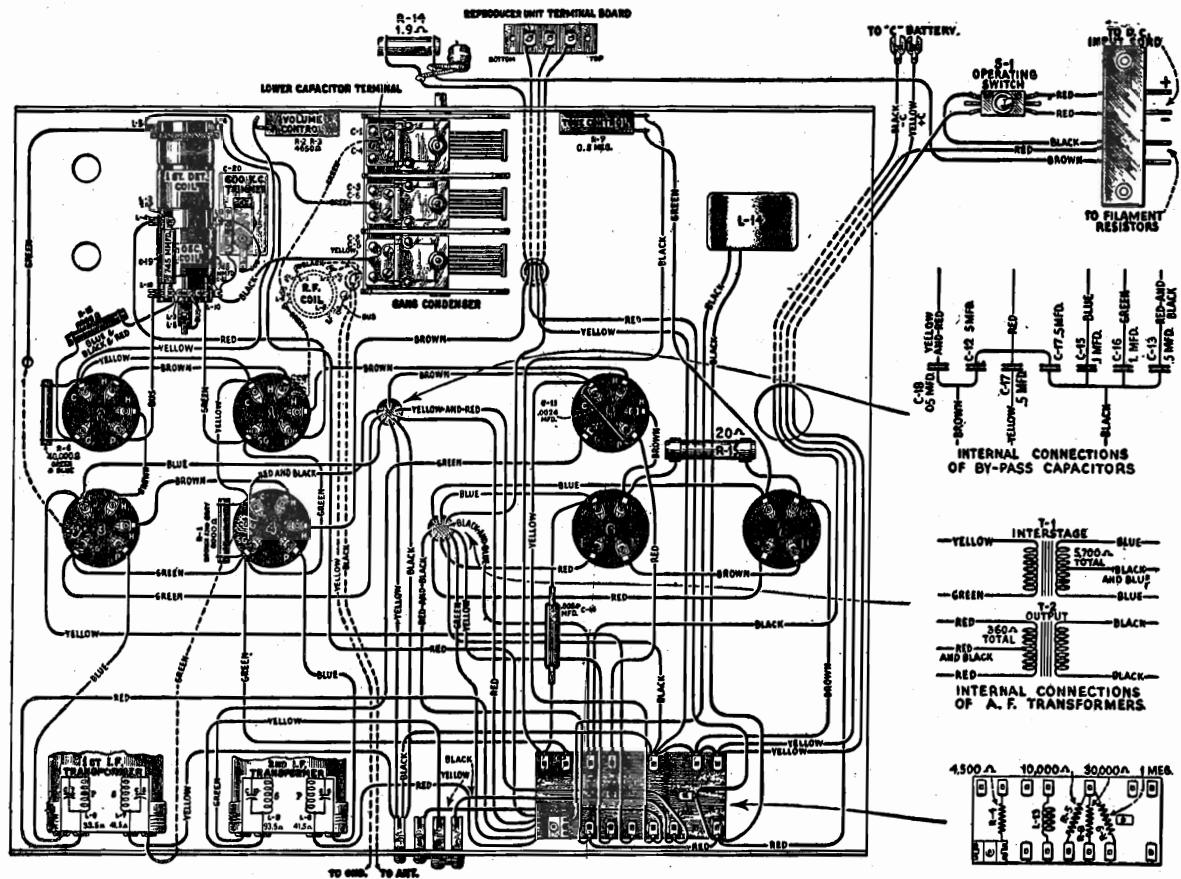

Part No.	DESCRIPTION	List Price
PARTS COMMON TO R-7 D.C. AND R-9 D.C.		
2240	Resistor—30,000 Ohms—Carbon type.....	\$0.70
2546	Resistor—1 Megohm—Carbon type—Package of 5...	3.00
2731	Resistor—10,000 Ohms—Carbon type—Package of 5.	2.00
2746	Socket—Dial lamp socket.....	.50
2749	Capacitor—2,400 Mmfd.—Used as 2nd Detector R.F. by-pass capacitor.....	1.50
2875	Knob—Station Selector, Tone Control or Volume Control Knob—Package of 5.....	1.50
2881	Bracket—Dial lamp bracket—Package of 5.....	.50
2882	Socket—Five prong Radiotron Socket complete with insulating shield—Five used.....	.50
2946	Escutcheon—Station Selector Escutcheon.....	.60
2968	Socket—Four prong Radiotron Socket complete with insulating shield—Two used.....	.50
2973	Board—Magnetic Pickup terminal board complete with terminals and screws—Package of 2.....	.50
2990	Resistor—4,500 ohms—Carbon type—Package of 5..	2.50
2991	Transformer—1st I. F. Transformer complete with shield and mounting screws.....	3.00
2992	Transformer—2nd I. F. Transformer complete with shield and mounting screws.....	3.00
2993	Board—Resistor mounting board complete with terminals and mounting brackets—less resistors...	1.00
2994	Coil—2nd Detector R.F. Choke Coil complete with rivet.....	.60
2995	Volume Control—complete less knob—Package of 5..	6.00
2996	Tone Control—Complete less knob—Package of 5...	6.00
2997	Coil—R.F. coil complete with mounting washer and nut.....	1.90
2998	Coil—1st Detector and Oscillator Coil assembly complete with mounting washers and nuts.....	2.40

Part No.	DESCRIPTION	List Price
2999	Shaft—Dial Scale drive shaft complete with mounting screws and lock washers.....	.50
3000	Scale—Dial drum and scale complete with set screws..	.60
3001	Resistor—1.9 Ohms—Porcelain resistor used in parallel with dial lamp.....	.60
3002	Resistor—20 Ohms—Porcelain resistor used across UX-245 filaments.....	.60
3003	Cushion—Sponge Rubber Cushions—Package of 4..	.50
3004	Resistor—Porcelain type—180 Ohms—used as heater supply resistor—Three used.....	1.80
3005	Screw Assembly—Loudspeaker Screws, Nuts, Eyelets and Washers—Package of 1 set of four each (for R-7).....	\$.50
3045	Resistor—40,000 ohms—Carbon type—Package of 5.	2.50
3071	Plug—Male and Female power plug—used as interlock—Set of 2 Complete plugs.....	1.60
3072	Resistor Unit—Resistor Unit complete for use on 220 volt D.C. lines.....	19.00
3073	Switch—Operating switch.....	.80
7054	Cord—Power Cord and Plug.....	1.00
7062	Condenser—Adjustable Oscillator trimming condenser.	1.00
7238	Capacitor Pack—R.F. by-pass capacitor pack in metal container.....	3.50
7239	Transformer—A.F. transformer assembly in metal container.....	6.00
7240	Reactor—Filter reactor.....	5.50
7241	Condenser—3-gang tuning condenser complete with mounting washers and screws.....	8.00
8559	Ring—Cone retaining ring.....	.80
8601	Cone—Cone complete—Package of 5.....	15.00
8639	Coil—Loudspeaker field coil complete with cone support.....	5.00
9323	Loudspeaker—Loudspeaker unit complete.....	8.70
9338	Receiver Assembly—Receiver Assembly complete—less loudspeaker and Radiotrons.....	40.00

MODEL R-7,R-9 DC
Superette
Resistance Data

R. C. A. VICTOR CO., INC.

60 ohms
13,30 ohms
58+ ohms* *Resistance of filter
choke not known

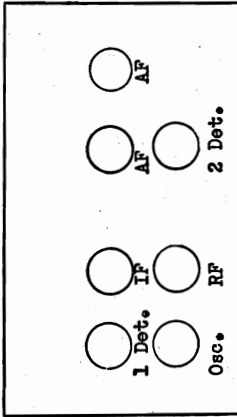

Across Filament interlocks
Across Speaker field
RF Plate to + DC Switch

Correct Incorrect

From Chassis To Aerial to Ground 40 ohms

Chassis to

RF Control Grid 5 ohms
RF Cathode(V.C. Max) 150 ohms
RF Cathode(V.C. Min) 4,650 ohms
RF Screen Grid 8,150 ohms
RF Plate 12,708 ohms
RF Plate to 1 Detector Plate 151.5 ohms

TC-Y (.5 mfd)
BC-Y (.5 mfd)
BC-Y (1. mfd)
BC-Y (1. mfd)
BC-2D P-2DK (0024 mfd)
BC-2D P-2DK (.5 mfd)

6 ohms
10,000 ohms
8,150 ohms
12,743.5 ohms

40,150 ohms
150 ohms
8,151 ohms
1 ohm

41.5 ohms
150 ohms
8,150 ohms
0 ohms
12,691.5 ohms
99.5 ohms

Pickup Terminal Broad Terminals 1 and 2 joined

2 Detector Control Grid 1,000,083.5 ohms
2 Detector Control Grid to Ter#2 93.5 ohms
2 Detector Cathode 30,000 ohms
2 Detector Plate 13,300 ohms

Output Control Grid to Black Bias Lead 3,850 ohms
Output Grid to Grid 5,700 ohms
Output Grid to chassis(bias leads shorted) 3,850ohms
Output Plate to +D.C.Switch 180 ohms
Output Plate to Plate 360 ohms

1 Output filament terminal and chassis 20 ohms
Across dial light socket 1.9 ohms

RADIOTRON SOCKET VOLTAGES—115 or 230 Volt Line
(Separate Resistance Unit Used with 230 Volt Line)

Tube No.	Cathode to Heater Volt, D.C.	Cathode to Filament to Control Volt, D.C.	Screen Grid to Cathode Volt, D.C.	Cathode or Filament to Plate Volt, D.C.	Plate Current M. A.	Screen Grid Current M. A.	Heater or Filament Volt, A.C.
VOLUME CONTROL AT MINIMUM							
1	40	30	40	75	0	0	2.3
2	20	0	40	40	2.0	0	2.3
3	6.0	3.5	65	100	.25	—	2.3
4	17.0	26	40	75	0	0	2.3
5	2.0	25.0	—	90	.23	—	2.3
6	—	25.0	—	100	4.0	—	2.3
7	—	25.0	—	100	4.0	—	2.3
VOLUME CONTROL AT MAXIMUM							
1	10.0	2.0	50	100	3.5	400.5	2.3
2	6.0	0	50	50	3.0	—	2.3
3	8.0	5.0	50	100	0.5	—	2.3
4	10.0	2.0	50	100	2.5	11.0	2.3
5	2.0	25.0	—	90	.25	—	2.3
6	—	25.0	—	100	4.0	—	2.3
7	—	25.0	—	100	4.0	—	2.3

*Not true reading due to Resistance in circuit
**This may be plus or minus depending on age of tubes

R. C. A. VICTOR CO., INC.

MODEL R-7A AC
Superette
Schematic

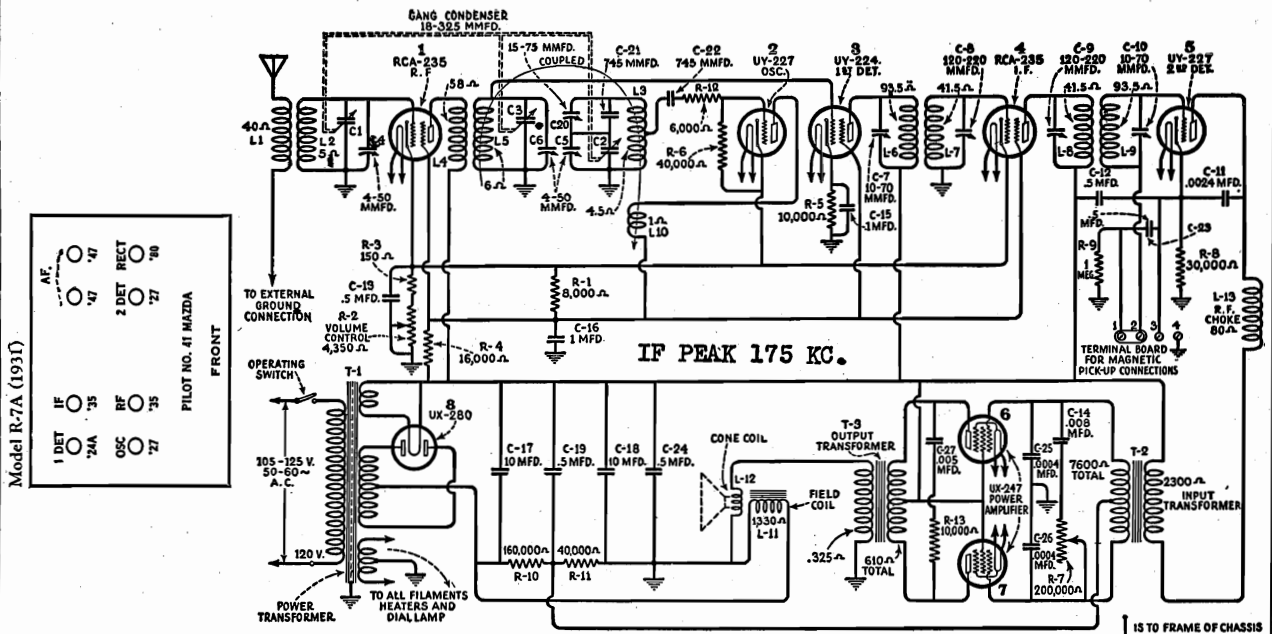

Figure 1—Schematic Diagram

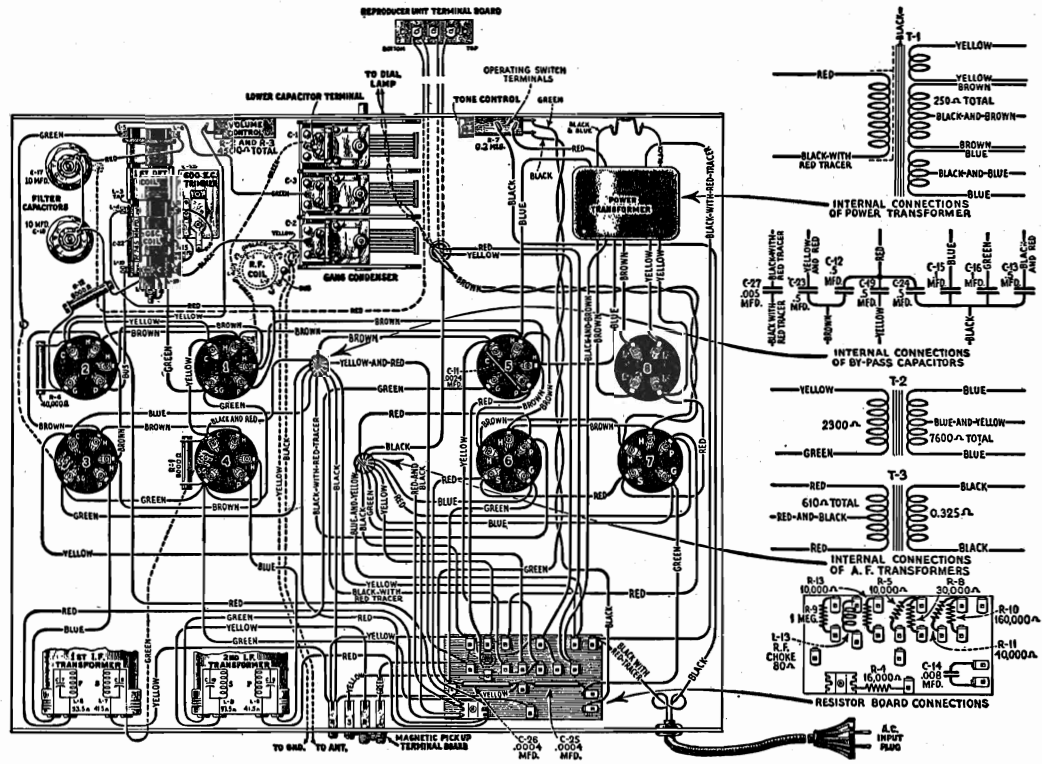

Figure 2—Wiring Diagram

RADIOTRON SOCKET VOLTAGES—110 VOLT A. C. LINE

Radiotron No.	Cathode to Heater Volts D. C.	Cathode or Filament to Control Grid Volts D. C.	Cathode to Screen Grid Volts D. C.	Cathode or Filament to Plate Volts D. C.	Plate Current M. A.	Heater or Filament Volts A. C.	Radiotron No.	Cathode to Heater Volts D. C.	Cathode or Filament to Control Grid Volts D. C.	Cathode to Screen Grid Volts D. C.	Cathode or Filament to Plate Volts D. C.	Plate Current M. A.	Heater or Filament Volts A. C.
VOLUME CONTROL AT MINIMUM							VOLUME CONTROL AT MAXIMUM						
1	38	35	50	200	.0	2.2	1	2.0	2.5	60	235	3.5	2.2
2	38	0	—	50	3.5	2.2	2	2.0	.0	—	50	4.5	2.2
3	7	6	80	235	0.5	2.2	3	4.0	4.0	55	230	0.5	2.2
4	38	35	50	200	.0	2.2	4	2.0	2.5	58	235	3.5	2.2
5	22	8	—	210	0.7	2.2	5	22	8	—	210	0.7	2.2
6	—	12	225	220	30	2.2	6	—	12	225	220	30	2.2
7	—	12	225	220	30	2.2	7	—	12	225	220	30	2.2

MODEL R-7A AC
Superette
Resistance Data

R. C. A. VICTOR CO., INC.

Harmonic condenser

- '47 Plate to '80 Fil 305 ohms
- '47 Plate to '47 Plate 610 ohms
- '80 Anode 200,125 ohms
- '80 Anode to '80 Anode 250 ohms
- Across Speaker field only 1,330 ohms
- Across output transformer secondary only .325 ohm
- Across Oscillator coil 4.5 ohms

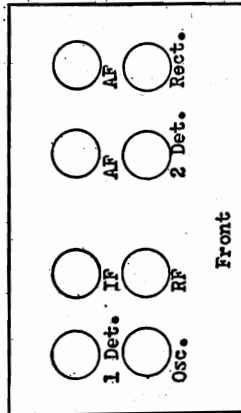

All tubes out of sockets and AC plug removed from power supply line. Field coil disconnected. Volume control maximum unless otherwise stated

Correct Incorrect

40 ohms

From Chassis To

Aerial to Ground

Chassis to

RF Control Grid

RF Cathode (V.C.Min)

RF Cathode (V.C.Max)

RF Screen Grid

RF Plate

5 ohms

4,500 ohms

150 ohms

8,150 ohms

24,208 ohms

RF Plate to '80 Fil

58 ohms

1 Detector Control Grid

1 Detector Cathode

1 Detector Screen Grid

1 Detector Plate to '80 Fil

6 ohms

10,000 ohms

8,150 ohms

24,301.5 ohms

93.5 ohms

Oscillator Control Grid

Oscillator Cathode

Oscillator Plate

Osc. Plate to '80 Fil

40,150 ohms

150 ohms

24,151 ohms

1 ohm

IF Control Grid

IF Cathode

IF Screen Grid

IF Plate

41.5 ohms

150 ohms

24,150 ohms

24,191.5 ohms

IF Plate -'80 Fil

41.5 ohms

2 Detector Control Grid

2 Det Control Grid- Ter #2

2 Detector Cathode

2 Detector Plate

1,000,093.5 ohms

93.5 ohms

30,000 ohms

26,530 ohms

2 Detector Plate to '80 Fil

2,380 ohms

'47 Control Grid

43,800 ohms

'47 Screen Grid

'47 Cg to '47 Cg

'47 Screen to '80 Fil

'47 Plate

24,150 ohms

7,600 ohms

0 ohm

24,455 ohms

RADIATION SOCKET VOLTAGES—110 VOLT A. C. LINE

Radiation No.	VOLUME CONTROL AT MINIMUM			VOLUME CONTROL AT MAXIMUM			Heater or Filament Voltage A.C.			
	Cathode to Plate V.D.C.	Cathode to Grid V.D.C.	Grid to Plate V.D.C.	Cathode to Plate V.D.C.	Cathode to Grid V.D.C.	Grid to Plate V.D.C.				
1	38	35	50	300	2.0	2.5	60	235	3.5	2.2
2	38	6	—	50	3.5	—	—	50	4.5	2.2
3	7	6	80	235	4.0	4.0	55	230	0.5	2.2
4	30	31	50	200	2.0	2.0	38	235	3.5	2.2
5	22	18	8	235	2.0	2.2	—	230	3.0	2.2
6	—	—	—	—	—	—	—	235	2.0	2.2
7	—	—	—	—	—	—	—	235	2.0	2.2
8	—	—	—	—	—	—	—	235	2.0	2.2
9	—	—	—	—	—	—	—	235	2.0	2.2
10	—	—	—	—	—	—	—	235	2.0	2.2

MODEL R-8, R-12 AC
Chassis
Parts List

R. C. A. - VICTOR CO., INC.

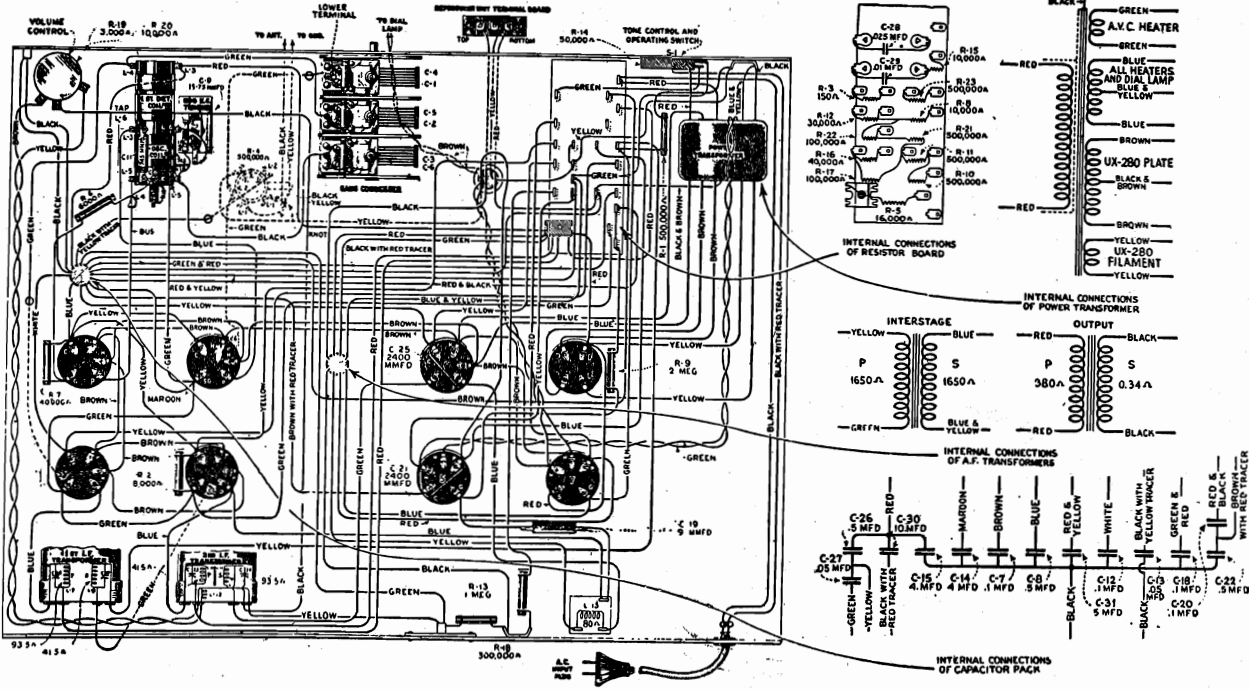

Stock No.	DESCRIPTION	List Price	Stock No.	DESCRIPTION	List Price
7343	Transformer—Audio transformer.....	\$3.85	7343	Transformer—Audio transformer.....	\$3.85
7344	Transformer—Power transformer.....	8.00	7344	Transformer—Power transformer.....	8.00
7346	Board—Resistor board complete less resistors and capacitors.....	2.30	7346	Board—Resistor board complete less resistors and capacitors.....	2.30
7362	Capacitor—0.025 mid.....	1.00	7362	Capacitor—0.025 mid.....	1.00
8770	Transformer—Power transformer—105-125 volts, 25-40 cycles.....	12.00	8770	Transformer—Power transformer—105-125 volts, 25-40 cycles.....	12.00
8771	Transformer—Power transformer—220 volts, 60 cycles.....	9.00	8771	Transformer—Power transformer—220 volts, 60 cycles.....	9.00
8837	Support—Receiver chassis metal mounting bracket—Package of 4.....	.70	8837	Support—Receiver chassis metal mounting bracket—Package of 4.....	.70
2999	SHAFT—TUNING CONDENSER DRIVE SHAFT COMPLETE.....	.50	2999	SHAFT—TUNING CONDENSER DRIVE SHAFT COMPLETE.....	.50
3029	Bracket—Dial lamp bracket and indicator.....	.50	3029	Bracket—Dial lamp bracket and indicator.....	.50
3097	Scale—Dial drum and scale with set screws—Package of 2.....	.50	3097	Scale—Dial drum and scale with set screws—Package of 2.....	.50
7241	Capacitor—3 gang tuning capacitor.....	8.00	7241	Capacitor—3 gang tuning capacitor.....	8.00
6189	Bracket—Dial lamp bracket and indicator—Pkg. of 2.....	.65	6189	Bracket—Dial lamp bracket and indicator—Pkg. of 2.....	.65
6190	Shaft—Tuning condenser drive shaft complete with 3 washers—Package of 5.....	.85	6190	Shaft—Tuning condenser drive shaft complete with 3 washers—Package of 5.....	.85
6191	Cord—Tuning condenser drive cord—Package of 5.....	.55	6191	Cord—Tuning condenser drive cord—Package of 5.....	.55
6192	Spring—Tuning condenser drive cord tension spring—Package of 10.....	.50	6192	Spring—Tuning condenser drive cord tension spring—Package of 10.....	.50
7438	Capacitor—Variable tuning capacitor.....	5.20	7438	Capacitor—Variable tuning capacitor.....	5.20
7439	Drum—Dial drum with set screw.....	.50	7439	Drum—Dial drum with set screw.....	.50
7440	Scale—Dial and dial scale.....	.75	7440	Scale—Dial and dial scale.....	.75
6174	LOUDSPEAKER Screw assembly—Speaker mounting screw assembly—Comprising 4 screws, 8 nuts, 4 washers and 4 eyes—Package of 1 set—For R-8.....	.50	6174	LOUDSPEAKER Screw assembly—Speaker mounting screw assembly—Comprising 4 screws, 8 nuts, 4 washers and 4 eyes—Package of 1 set—For R-8.....	.50
8237	Screw assembly—Speaker mounting screw assembly—Comprising 4 screws, 8 nuts, 4 washers and 4 eyes—Package of 1 set—For R-12.....	.50	8237	Screw assembly—Speaker mounting screw assembly—Comprising 4 screws, 8 nuts, 4 washers and 4 eyes—Package of 1 set—For R-12.....	.50
6184	Board—Terminal board complete with 3 terminals and mounting rivets—Package of 5.....	.50	6184	Board—Terminal board complete with 3 terminals and mounting rivets—Package of 5.....	.50
7345	Coil—Speaker field coil assembly—Comprising coil, cone housing and magnet.....	5.00	7345	Coil—Speaker field coil assembly—Comprising coil, cone housing and magnet.....	5.00
8559	Ring—Cone retaining ring.....	.80	8559	Ring—Cone retaining ring.....	.80
8601	Cone—Speaker paper cone—Package of 5.....	15.00	8601	Cone—Speaker paper cone—Package of 5.....	15.00
X-32	R-R CABINET PARTS Baffle board and grille cloth.....	.90	X-32	R-R CABINET PARTS Baffle board and grille cloth.....	.90
6113	Foot—Cabinet felt foot—Package of 15.....	.50	6113	Foot—Cabinet felt foot—Package of 15.....	.50
7485	Encutcheon—Tuning dial encutcheon complete with mounting screws.....	9.00	7485	Encutcheon—Tuning dial encutcheon complete with mounting screws.....	9.00
9402	Cabinet—Cabinet complete less equipment.....	16.00	9402	Cabinet—Cabinet complete less equipment.....	16.00
X-44	R-12 CABINET PARTS Top.....	4.65	X-44	R-12 CABINET PARTS Top.....	4.65
X-45	Leg.....	2.00	X-45	Leg.....	2.00
X-46	Foot.....	1.10	X-46	Foot.....	1.10
X-47	Stretch.....	4.50	X-47	Stretch.....	4.50
X-48	Baffle board and grille cloth.....	.95	X-48	Baffle board and grille cloth.....	.95
X-49	Mountings—Control panel mountings—Comprising 1 box with multiple vertical adjusting mounting and 2 center ornaments—Package of 1 set.....	3.95	X-49	Mountings—Control panel mountings—Comprising 1 box with multiple vertical adjusting mounting and 2 center ornaments—Package of 1 set.....	3.95
7441	Encutcheon—Tuning dial encutcheon complete with mounting screws.....	1.05	7441	Encutcheon—Tuning dial encutcheon complete with mounting screws.....	1.05
9405	Cabinet—Cabinet complete less equipment.....	47.50	9405	Cabinet—Cabinet complete less equipment.....	47.50

R. C. A. VICTOR CO., INC.

MODEL R-8, R-12 AC
Resistance Data

All tubes removed from sockets and AC plug removed from power supply
Field coil disconnected

From Chassis To	Correct	Incorrect
Aerial to Ground	40 ohms	
Chassis to		
RF Control Grid	1,000,005 ohms	TC- rf Cg-Y BC- rf wdg-Y (.05 mfd) BC- if Tr-Y (.1 mfd) BC-AVC P-AVC K BC- rf K-Y (.5 mfd) FC- rf Sg-Y (4. mfd) FC-80F-80A (10 mfd) FC-47 Sg-Y (4.mfd) BC-2D Tr-2DK (.5 mfd)
RF Cathode	150 ohms	
RF Screen	8,150 ohms	
RF Plate	24,208 ohms	
1 Detector Control Grid	5 ohms	TC-1D Cg-Y
1 Detector Cathode	10,000 ohms	BC-IDK-Y (.1 mfd)
1 Detector Screen Grid	8,150 ohms	See RF Screen
1 Detector Plate	24,301.5 ohms	See RF Plate
1 Det Plate to '80 Fil	93.5 ohms	TC-IF Tr Primary
Oscillator Control Grid	40,150 ohms	Oscillator Grid Condenser
Osc Control Grid to Osc Cathode	40,000 ohms	
Oscillator Cathode	150 ohms	See RF Cathode
Oscillator Plate	24,151 ohms	See RF Plate
Osc Plate to RF Screen	1 ohm	
IF Control Grid	500,041.5 ohms*	*Includes IF Transformer secondary
IF Cathode	150 ohms	BC- IF Tr-Y (.1 mfd)
IF Screen Grid	8,150 ohms	See RF Cathode
IF Plate to '80 Fil	41.5 ohms	See RF Screen
AVC Control Grid	3,240,000 ohms	TC-IF Tr. Primary See RF Control Grid See RF Plate BLC- if P-AVC Cg(9 mmfd)
AVC Control Grid-'80 Anode	3,000,175 ohms	BC-AVC Cg res-AVC H-K
AVC Cathode	250,000 ohms	BC-AVC K-AVC H (.1 mfd)
AVC Plate	1,000,000 ohms	See RF Control Grid
2 Detector Control Grid	1,000,093.5 ohms*	BC AVC P-AVC K(.0024 mfd)
2 Det Cg to Volume Control	843-93.5-10,093.5 ohms	*Includes IF Tr Sec Depends upon setting of volume control
2 Detector Cathode	30,000 ohms	BC-2 DK (.05 mfd)

Component	Resistance	Notes
2 Detector Plate to '80 Fil	1,730 ohms	See RF Plate
2 Det Plate	241,650 ohms	BC- 2 DP-2 DK FC-'47 Sg-Y (4 mfd) See RF Plate
'47 Control Grid	91,650 ohms	Tone Control Condenser See RF Control Grid
'47 Screen Grid to '80 Fil	0 ohm	
'47 Plate to '80 Fil	380 ohms	Harmonic condenser
'80 Filament	264,150 ohms	FC-80F-80P (10 mfd) See RF Control Grid
'80 Plate to '80 Plate	350 ohms	See RF Plate
Output Transformer Secondary only	.34ohm	
Oscillator Coil	6. ohms	
Oscillator Grid resistor	6,000 ohms	
Field Coil only	1,330 ohms	

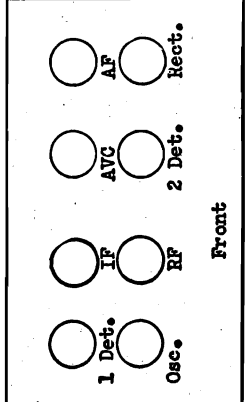

VOLUME CONTROL DOES NOT AFFECT VOLTAGES

Resistor No.	Calculated Value Volts D.C.	Calculated Value Volts A.C.	Calculated Value Volts A.C.	Calculated Value Volts A.C.	Calculated Value Volts A.C.
1. H.F.	4.0	0.5	70	300	4.0
2. Det.	1.0	0	—	65	6.0
3. 1st Det.	7.0	6.0	70	300	0.75
1. I.F.	1.0	1.0	70	300	1.0
5. 2nd Det.	20.0	10.0	—	250	1.0
6. A. V. I.	0	0	—	25	0
7. Power	0	10.0	300	35.0	35.0

MODEL R-10 AC
Schematic
Voltage - Chassis

R. C. A. VICTOR CO., INC.

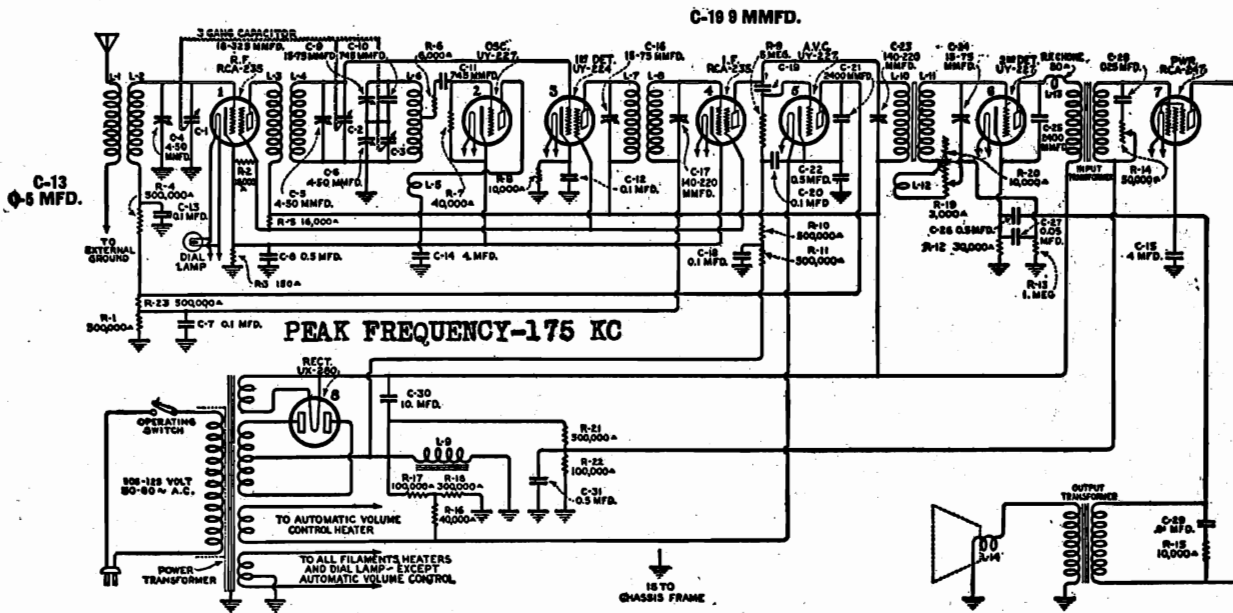

110 VOLT A. C. LINE
 (Volume Control Setting Does Not Affect Voltages)

Radiotron No.	Cathode to Heater Volts, D. C.	Cathode or Filament to Control Grid Volts, D. C.	Cathode or Filament to Screen Grid Volts, D. C.	Cathode or Filament to Plate Volts, D. C.	Plate Current M. A.	Screen Current M. A.	Heater or Filament Volts, A. C.
1	2	*0.1	75	210	5.0	0.5	2.2
2	8	0	—	60	5.0	—	2.2
3	7	7.0	70	205	0.5	0.1	2.2
4	2	*0.1	75	210	5.0	0.5	2.2
5	0	0	—	30	0	—	2.2
6	20	*8.0	—	185	0.5	—	2.2
7	—	10	210	210	25	—	2.2

*Not true reading due to resistance in circuit.

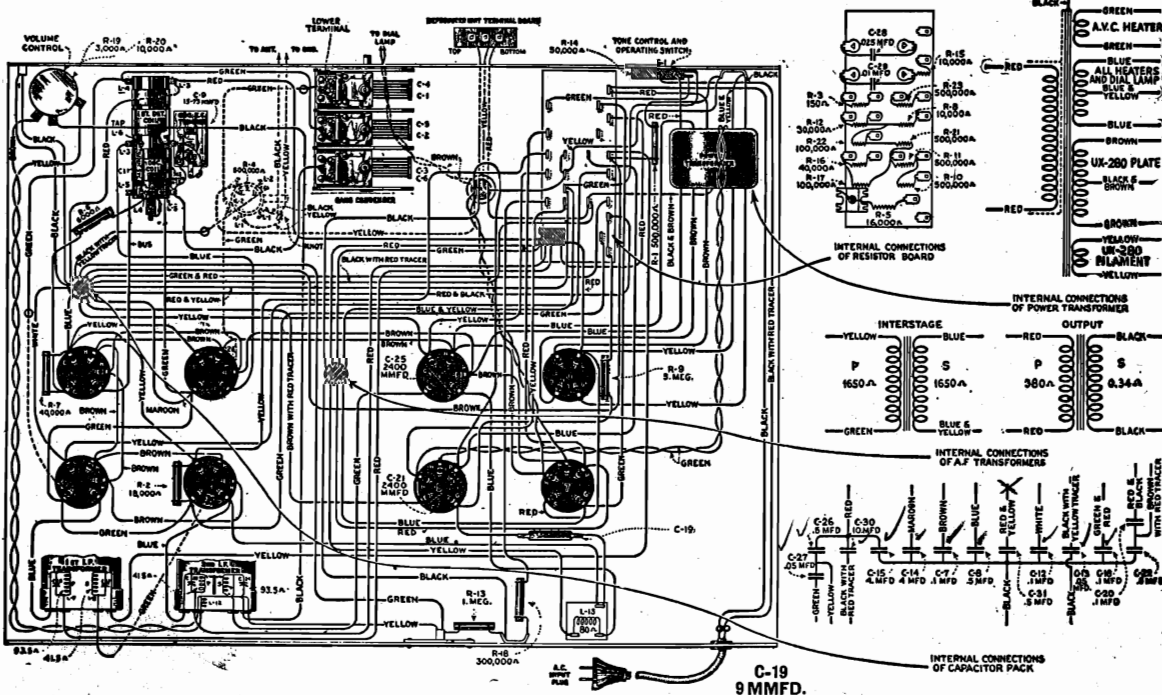

R. C. A. VICTOR CO., INC.

MODEL R-10 AC
Resistance Data

All tubes out of sockets and AC plug removed from power supply lines
Speaker field disconnected

from Chassis To
Aerial to Ground
Chassis to
RF Control Grid
RF Cathode
RF Screen Grid
RF Plate
RF Plate to '80 Fil
1 Detector Control Grid
1 Detector Cathode
1 Detector Screen Grid
1 Detector Plate
1 Detector Plate - '80 Fil
Oscillator Control Grid
Oscillator Cathode
Osc Screen Grid
Osc Plate
Osc Plate - RF Screen
IF Control Grid
IF Cathode
IF Screen Grid
IF Plate
IF Plate to '80 Fil
AVC Control Grid
AVC Cathode
2 Detector Control Grid
2 Det Cg to Vol Control
2 Detector Cathode
2 Detector Plate
2 Detector Plate to '80 Fil

Correct
40 ohms
1,500,005 ohms
150 ohms
18,150 ohms
34,208 ohms
58 ohms
5 ohms
10,000 ohms
18,150 ohms
34,301.5 ohms
93.5 ohms
40,150 ohms
150 ohms
18,150 ohms
18,151 ohms
1 ohm
500,041.5 ohms
150 ohms
18,150 ohms
34,191.5 ohms
41.5 ohms
6,240,000 ohms
250,000 ohms
1,000,095 ohms
93.5-10,093 ohms
30,000 ohms
35,880 ohms
1,730 ohms

Incorrect
TC-Y
BLC in tuned circuit
BC-Y
BC-AVC P-AVC K
BC-Y (.5 mfd)
BC-rf K-Y (.5 mfd)
BC-2 D P-Y (0024 mfd)
BC-AFT. Pr = 2 D K (.5 mf)
FC-'47 Sg-Y (4. mfd)
TC-Y
BC- 1 D K-Y (.1 mfd)
See RF Screen Grid
See RF Plate
TC- IF Tr Pri
Osc Grid Condenser
See RF Cathode
See RF Screen
See RF Screen
BC-Y (.5 mfd)
TC-IF Tr Sec
See RF Cathode
See RF Screen Grid
See RF Plate
BLC-AVC Cg-if P
BC-5 meg res. - AVC H
FC-'80 P = '80 P wdg(10mf)
BC-'47 Cgwdg = Y
BC-AVC K-Y
BC-AVC E-AVC P
BC- 2 D K (.5 mfd)
BC- 2DK-2DF
BC- 2DF-2DK

91,650 ohms BC-Y Tone Control Condenser
0 ohms See IF Plate
34,150 ohms FC-'47 Sg-Y (4.mfd)
34,550 ohms

Correct Incorrect
From Chassis To
'47 Control Grid
'80 Fil
'47 Screen to chassis
'47 Plate
From Chassis To
'47 Plate -'47 Screen
'80 Fil
'80 Fil to '80 Anode
'80 Anode to '80 Anode
Across Field Coil only
Across Output Transformer Secondary only 0.84 ohms

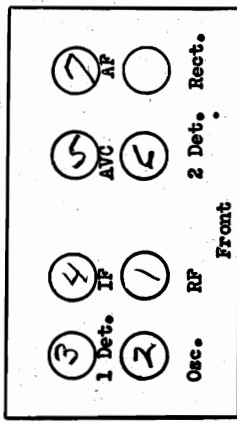

110 VOLT A. C. LINE
(Volume Control Setting Does Not Affect Voltages)

Radio- No.	Cathode or Filament to Heater Volta, D. C.	Cathode or Filament to Screen Grid Volts, D. C.	Cathode or Filament to Plate Volt, D. C.	Plate Current M. A.	Screen Current M. A.	Heater or Filament Volts, A. C.
1	2	75	210	5.0	0.5	2.2
2	8	0	60	5.0	—	2.2
3	7	7.0	205	0.5	0.1	2.2
4	2	75	210	5.0	0.5	2.2
5	0	—	30	0	—	2.2
6	20	8.0	185	0.5	—	2.2
7	—	10	210	25	—	2.2

*Not true reading due to resistance in circuit

R. C. A. VICTOR CO., INC.

MODEL R-11 AC
Schematic
Early
Voltage

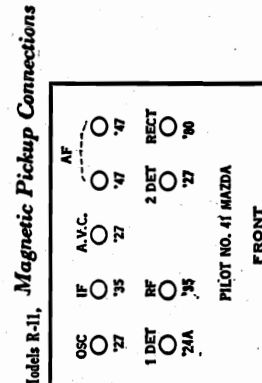
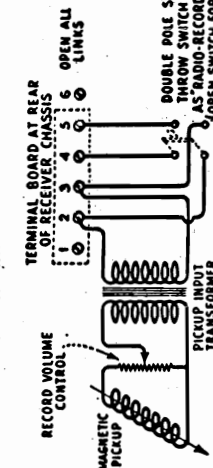
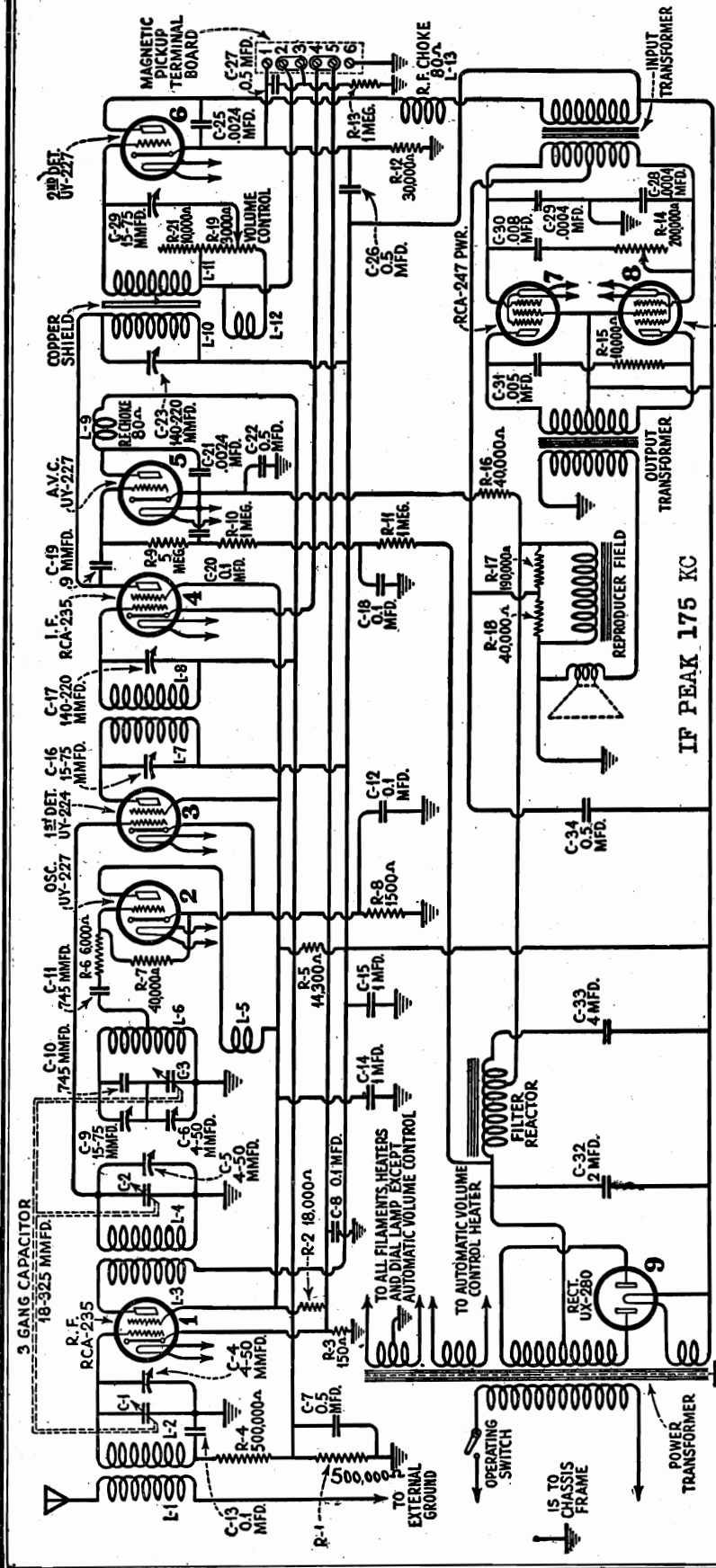

110 VOLT A. C. LINE (Volume Control Setting Does Not Affect Voltages)

Radiotron No.	Cathode to Heater Volts D. C.	Cathode or Filament to Control Grid Volts, D. C.	Cathode or Filament to Screen Grid Volts, D. C.	Cathode or Filament to Plate Volts, D. C.	Plate Current M. A.	Screen Current M. A.	Heater or Filament Volts, A. C.
1	2	*0.1	75	205	5.0	0.5	2.2
2	8	0	—	60	5.0	—	2.2
3	7	7.0	70	200	0.5	0.1	2.2
4	2	*0.1	75	205	5.0	0.5	2.2
5	0	0	—	25	0	—	2.2
6	20	*8.0	—	180	0.5	—	2.2
7	—	10	210	205	25	—	2.2
8	—	10	210	205	25	—	2.2

* Not true reading due to resistance in circuit.

R. C. A. VICTOR CO., INC.

MODEL R-11 AC
Parts List
Notes

RCA Victor Console, R-11

REPLACEMENT PARTS

Stock No.	DESCRIPTION	List Price	Stock No.	DESCRIPTION	List Price
2563	Resistor—6,000 ohms—Carbon type—Package of 5	\$3.00	3097	Scale—Dial drum scale with set screws—Pkg. of 2	\$0.50
2730	Resistor—18,000 ohms—Carbon type—Package of 5	2.00	3098	Capacitor—0.008 mfd.	.50
2734	Capacitor—745 mmfd.—Package of 5	2.20	3099	Capacitor—0.005 mfd.	.75
2746	Socket—Dial lamp socket	.50	7054	Cord—Power cord	1.00
2747	Contact cap—Package of 5	.50	7062	Capacitor—Adjustable oscillator trimmer capacitor	1.00
2749	Capacitor—2400 mmfd.	1.50	7241	Capacitor—3 gang tuning capacitor with mounting screws and washers	8.00
2875	Knobs—Package of 5	1.50	7266	Transformer—1st intermediate transformer	3.00
2882	Socket—UY Radiotron socket—Complete with insulating shield—8 used	.50	7267	Transformer—2d intermediate transformer	3.00
2968	Socket—UX Radiotron socket—Complete with insulating shield—1 used	.50	7268	Coil—Detector or A.V.C. R.F. choke coil—Complete with mounting rivet	.60
2999	Shaft—Dial drum drive shaft	.50	7269	Capacitor pack—In metal container—60 cycle	7.25
3029	Indicator—Tuning dial indicator—Complete with bracket	.50	7270	Reactor—Filter reactor	4.00
3046	Resistor—190,000 ohms—Carbon type—Package of 5	2.50	7271	Transformer—Interstage transformer	4.25
3047	Resistor—1500 ohms—Carbon type—Package of 5	2.50	7272	Transformer—Power transformer—105-125 volt. 50-60 cycles	12.00
3048	Resistor—500,000 ohms—Carbon type—Package of 5	2.50	7273	Capacitor pack—By-pass capacitor pack—25-40 cv.	10.00
3049	Resistor—150 ohms—Carbon type—Package of 5	2.50	7274	Transformer—Power transformer—105-125 volts, 25-40 cycles	15.00
3050	Resistor—14,000 ohms—Carbon type—Package of 1	.60	7275	Transformer—Power transformer—220 volts, 50-60 cycles	10.00
3051	Resistor—5 megohm—Carbon type—Package of 5	2.00			
3053	Capacitor—9 mmfd.—Package of 2	.50			
3054	Escutcheon—Station selector escutcheon—With 4 mounting screws	.60			
3055	Cushion—Chassis support cushion—Package of 4	.50	7257	Coil—Cone support with retaining ring, magnet and field coil	6.00
3056	Shield—Radiotron shield—6 used—Package of 2	.50	7258	Transformer—Output transformer	1.70
3076	Resistor—1 megohm—Carbon type—Package of 5	2.50	8539	Ring—Cone retaining ring	.80
3077	Resistor—30,000 ohms—Carbon type—Package of 5	2.50	8601	Cone—Cone with voice coil—Package of 5	15.00
3078	Resistor—10,000 ohms—Carbon type—Package of 5	2.50			
3079	Resistor—40,000 ohms—Carbon type—Package of 5	2.50			
3085	Capacitor—400 mmfd.	.60			
3089	Terminal board—Magnetic pickup terminal board	.50	8691	Panel—Control panel	8.50
3090	Board—A. V. C. and 2nd detector R. F. choke mounting board—Less choke coils	.50	8692	Grille cloth and baffle board	.90
3091	Board—Resistor board—Less resistor and capacitors	1.00	8693	Leg—Front—Right or left	1.25
3092	Volume control—Complete with mounting nut	1.50	8694	Leg—Back—Right hand	1.00
3093	Tone control—Complete with mounting nut	1.90	8695	Leg—Back—Left hand	1.00
3094	Shield—Radiotron shield—1 used—Package of 2	.50	8696	Stretcher	2.50
3095	Coil—R.F. coil—Complete with mounting bracket	1.90	8697	Foot	.75
3096	Coil—1st detector and oscillator coil—Complete with mounting bracket	3.55	8698	Top	5.50
			8699	Ornament—Control panel ornament	2.25
			9358	Cabinet—Complete less all equipment	62.50

In previous automatic volume control receivers, the volume control was placed in the grid circuit of the automatic volume control tube, its action being to vary the control grid voltage of this tube. When operating sets of this character, the receiver jumped to full sensitivity when not tuned to a signal and if in a noisy location, this noise was very objectionable.

In this instrument, however, the volume control is not in the automatic volume control tube circuit, but in the grid circuit of the second detector. By means of it the signal voltage applied to the second detector is controlled and under no conditions can noise or other signals exceed the level for which it has been set. Electrically, the primary and secondary of the second I. F. transformer are shielded from each other so that there is no transference of energy except by means of a small pickup coil. The volume control is a potentiometer shunted across this coil which determines the amount of pickup that will be used. As a further means of controlling a strong signal, a second section is provided which places up to 10,000 ohms (R-21) in series with the tuned circuit of second detector grid. This effectively reduces even the most powerful signals received.

A 0.005 mfd. condenser connected in series with a 10,000 ohm resistor is

placed across the primary of the output transformer. This functions to reduce the third harmonic distortion, an inherent characteristic of the Pentode output tube. The direct plate and grid voltages are supplied from high voltage alternating current which is rectified by means of Radiotron UX-280. The filter is of the tapped reactor type which gives an output of well filtered D. C. The bias voltage for the Radiotrons RCA-247 is obtained by using a portion of the drop across the reproducer field. One 190,000 ohm and one 40,000 ohm resistors act as the voltage dividing resistors.

A tone control, consisting of a 0.008 mfd. condenser in series with a 200,000 ohm variable resistor connected across the two grids of Radiotrons RCA-247 is incorporated in this stage. The tone control functions to reduce the high frequency output as the resistance is reduced. At the extreme low position, the condenser and secondary of the A. F. transformer resonate at a low frequency and thereby further accentuate the bass response. The two 0.0004 mfd. condensers, connected in series with their mid-point grounded are connected across the secondary of the input transformer. The purpose of these condensers is to prevent audio oscillations and provide a high frequency audio cut-off.

The next circuit to examine is the first detector. The circuit is tuned by means of one of the gang condensers to the frequency of the incoming signal. Radiotron UY-224 is used in this stage. In the grid circuit there is present the incoming signal and the oscillator signal, the latter being at a 175 K. C. difference from the former. The first detector is biased so as to operate as a plate rectification detector and its purpose is to extract the difference or beat frequency, produced by combining the signal and oscillator frequencies. The beat frequency—175 K. C.—appears in the plate circuit of the first detector which is accurately tuned to 175 K. C.

The next stage is that of the I. F. amplifier. A single stage is used, requiring two I. F. transformers, consisting of four tuned circuits. The plate circuit of the first detector, the grid and plate circuit of the I. F. amplifier and the grid circuit of the second detector are all tuned to 175 K. C. Radiotron RCA-235 is used in this stage and its control grid voltage is also varied by means of the automatic volume control tube.

SERVICE DATA

Information pertaining to general service data for this type receiver may be obtained from the Service Notes already issued on the RCA Victor Radiola Superette.

MODEL R-11 AC
Resistance Data

R. C. A. VICTOR CO., INC.

All tubes removed from sockets and AC plug removed from power supply.
Field coil disconnected

From Chassis To	Correct	Incorrect
Aerial to Ground post	40 ohms	
Chassis to		
RF Control Grid(early model)	1,000,005 ohms	BLC- in tuned circuit (.1 mfd)
RF Control Grid(late model)	1,500,005 ohms	BLC- in tuned circuit (.06 mfd)
RF Cathode	150 ohms	BC- rf K-Y (.1 mfd)
RF Screen Grid	18,150 ohms	BC- rf SG- Y (1. mfd)
RF Plate	32,508 ohms	BC-47 Sg- Y (.5 mfd)
RF Plate to '80 Fil	58 ohms	BC-'80 F- Splr div. tap
1 Detector Cathode	5 ohms	BC- rf P-Y (1. mfd)
1 Detector Cathode	1,500 ohms	See RF Screen Grid
1 Detector Screen	18,150 ohms	TC-Y
1 Detector Plate	32,541.5 ohms	BC-Y (.1 mfd)
1 Detector Plate to '80 Fil	93.5 ohms	See R-F Screen
Oscillator Control Grid	41,500 ohms	See R-F Plate
Oscillator Cathode	1,500 ohms	TC- 1 IF Tr.
Oscillator Plate	18,151 ohms	BLC-Osc Grid Cir. (.0074)
IF Control Grid (all models)	500,041.5 ohms	BC-Osc K-Y (.1 mfd)
IF Control Grid- AVC Plate (early)	121.5 ohms	BC-Osc K-Y (.1 mfd)
IF Screen Grid	18,150 ohms	See R-F Screen
IF Plate	32,491.5 ohms	BC-Y (.5 mfd)
IF Plate -'80 Fil	41.5 ohms	TC-1 IF Tr See
AVC Control Grid (early)	7,230,285 ohms	See RF Screen
AVC Control Grid (late)	4,230,285 ohms	See 1 Detector Plate
AVC Cathode	270,000 ohms	TC- 2 IF Tr-Pri.
AVC Plate	1,000,085 ohms	BLC- if P- AVC Cg(9mmfd)

From Chassis To	Correct	Incorrect
Pickup Board Terminal 2	1,000,000 ohms	BC-Ter#1- Ter#3
2 Detector Plate	34,830 ohms	See RF Plate
2 Detector Plate-'80 Fil	2,380 ohms	BC- 47 Cg-Y
'47 Control Grid	43,850 ohms	See AVC Cathode
'47 Control Grid to Control Grid	7,700 ohms	Tone Control Cond
'47 Screen	32,450 ohms	Tone Control Resist
'47 Screen - '80 Fil	0 ohms	See 2 Detector Plate
'47 Plate	32,755 ohms	See 2 Detector Plate
'47 Plate to Plate	610 ohms	Harmonic condenser
80 Anode to chassis	230,400 ohms	See AVC Control Grid
80 Anode to Anode	230 ohms	See RF Plate
80 Fil to chassis	32,450 ohms	See RF Screen Grid
Across Speaker field	860 ohms	

TC-2D Cg- VC Arm
BC-Ter#1-Ter#3
BC- 2 DK -'80 Fil

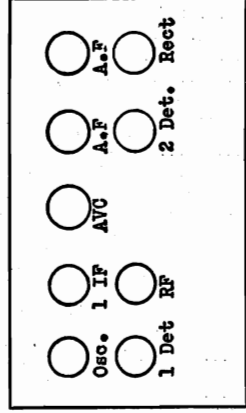

Line Voltage 110. Volume Control does not change voltages.

Tube	Cathode- Heater	Control Grid- Cathode	Screen Grid- Cathode	Plate- Cathode	Filament Current	Filament Voltage
RF	2.	0.1*	75.	205.	5.0 ma	2.2
Osc.	8.	0.	-	60.	5.0	2.2
1 Det.	7.	7.0	70.	200.	0.5	2.2
IF	2.	0.1*	75.	205.	5.0	2.2
AVC	0.	0.	-	25.	-	2.2
2 Det.	20.	8.0*	-	180.	0.5	2.2
Pwr	-	10.	210.	205.	25.	2.2
Pwr	-	10.	210.	205.	25.	2.2

* Not true reading due to resistance in the circuit.

R. C. A. VICTOR CO., INC.

MODEL RE-18
Schematic

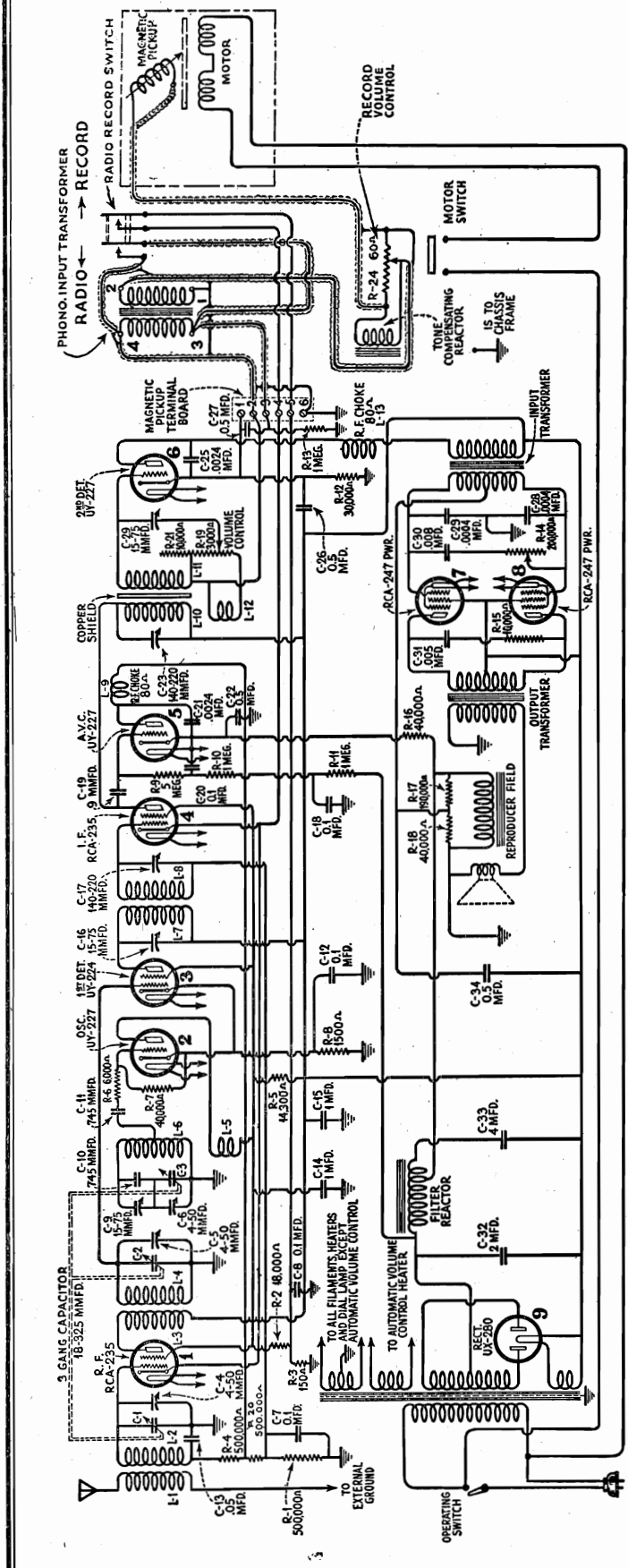

IF PEAK 175 KC.

Models R-11, RE-18, RE-18A, RAE-26 (1931)

OSC	27	1 DET	24A	AF	47	RECT	30
IF	35	RF	35	AV.C.	47	2 DET	27

PILOT NO. 41 MAZDA
FRONT

This is a combination radio and electrola incorporating a new type automatic volume control that is quiet between stations. The new motor - board equipment has a synchronous motor using the R. C. A. - Victor Inertia tone arm. The motor is fitted with a speed reducing gear that allows for the playing of both standard and Program Transcription Records.

In many respects this receiver is similar to the R. C. A. - Victor Model R-11 and methods similar to those used in servicing the R-11 can be applied to this Model, noting, of course, that there are some differences.

R. C. A. VICTOR CO., INC.

MODEL RE-18
Resistance Data

See Rf control grid
2 Det Control Grid(Pickup Board Term#2) 93.5 ohms
2 Det Control Grid to V.C. Arm 3,093.5-10,093.5 ohms TC-2D Cg- VC Arm

2 Det Cathode 30,000 ohms
Pickup Board Terminal 2 1,000,000 ohms
2 Detector Plate 34,830 ohms
2 Detector Plate-'80 Fil 2,380 ohms
'47 Control Grid 43,850 ohms
'47 Control Grid to Control Grid 7,700 ohms
'47 Screen 32,450 ohms
'47 Plate - '80 Fil 0 ohm
'47 Plate to Plate 32,755 ohms
80 Anode to chassis 610 ohms
80 Anode to chassis 230,400 ohms
80 Fil to chassis 230 ohms
80 Fil to chassis 32,450 ohms
Across Speaker field 860 ohms

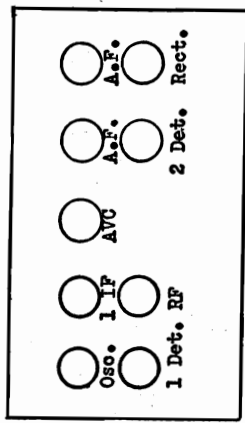

All Tubes removed from sockets and AC plug disconnected from power supply line. All phonograph equipment disconnected from pick up terminal board and terminals 2 and 3 inter-connected. Also terminals 4 and 5 inter-connected. Field Coil disconnected

From Chassis To Correct Incorrect
Aerial to Ground post 40 ohms
Chassis to
RF Control Grid(early model) 1,000,005 ohms BLC- in tuned circuit (.1 mfd)
RF Control Grid(late model) 1,500,005 ohms BLC- in tuned circuit (.06 mfd)
RF Cathode 150 ohms BC-AVC chk-Y
RF Screen Grid 18,150 ohms BC- rf K-Y (.1 mfd)
BC- rf Sg-Y (1. mfd)
BC- 47 Sg-Y (.5 mfd)
BC-'80 P- Spkr div. tap
BC- rf P-Y (1. mfd)
See RF Screen Grid

RF Plate 32,508 ohms
RF Plate to '80 Fil 58 ohms
1 Detector Control Grid 5 ohms
1 Detector Cathode 1,500 ohms
1 Detector Screen 18,150 ohms
1 Detector Plate 32,541.5 ohms
1 Detector Plate to '80 Fil 93.5 ohms
Oscillator Control Grid 41,500 ohms
Oscillator Cathode 1,500 ohms
Oscillator Plate 18,151 ohms
Osc Plate and Det Screen 1 ohm
IF Control Grid (all models) 500,041.5 ohms
IF Control Grid- AVC Plate (early) 121.5 ohms
IF Screen Grid 18,150 ohms
IF Plate 32,491.5 ohms
IF Plate - '80 Fil 41.5 ohms
AVC Control Grid (early) 7,230,285 ohms

AVC Control Grid (late) 4,230,285 ohms
AVC Cathode 270,000 ohms
TC-Y in tuned circuit (.1 mfd)
BC-AVC chk-Y
BC- 1 IF Tr. See X-Y
BC- rf K-Y (.1 mfd)
BC- rf Sg-Y (1. mfd)
BC- 47 Sg-Y (.5 mfd)
BC-'80 P- Spkr div. tap
BC- rf P-Y (1. mfd)
See RF Screen Grid
TC-Y
BC-Y (.1 mfd)
See R-F Plate
See R-F Screen
TC- 1 IF Tr.
BLC-Osc.Grid Cir.(0074)
BC-Osc K-Y (.1 mfd)
BC-Osc K-Y (.1 mfd)
See R-F Screen
BC-Y (.5 mfd)
TC-1 IF Tr Sec
See RF Screen
TC-2 IF Tr.Pri
BLC- 1f P- AVC Cg(9 mmfd)
BC-5 meg - AVC H (.1 mfd)
BC-1 meg- Y (.1 mfd)
FC-'80 Anode -80 F(2 mfd)
FC Filter chk-80 F(4 mfd)
BC-AVC K-Y (.5 mfd)
BC-Spkr divides tap- Y
BC-AVC K-AVC P(.0024 mfd)
See early model
BC-AVC K-AVC P
BC-AVC K-Y

Peak Frequency = 175 KC

Reduction No.	Cathode to Heater Voltage D.C.	Cathode to Filament to Control Grid Voltage, D.C.	Cathode or Filament to Screen Grid Voltage, D.C.	Cathode or Plate to Plate Voltage, D.C.	Plate Current M. A.	Screen Current M. A.	Heater or Filament Volts, A. C.
1	2	40.1	75	205	5.0	0.5	2.2
2	8	0	—	60	5.0	—	2.2
3	7	7.0	70	200	0.5	0.1	2.2
4	2	40.1	75	205	5.0	0.5	2.2
5	0	0	—	35	0	—	2.2
6	20	40.0	—	180	0.5	—	2.2
7	—	10	210	205	25	—	2.2
8	—	10	210	205	25	—	2.2

* Not true reading due to resistance in circuit.

MODEL RE-18-A
Parts List

R. C. A. VICTOR CO., INC.

RCA Victor Radiola Electrola RE-18A is a nine-tube combination super-heterodyne radio receiver and electric phonograph. Except for the cabinet and tuning dial, the RE-18A is similar to the RE-18. A reference to the RE-18 service notes should be made for information relative the circuits and similar data. The replacement parts are listed below.

ELECTRICAL SPECIFICATIONS

Voltage Rating.....105-125 Volts
 Frequency Rating....25, 30, 50 and 60 Cycles
 Power Consumption.....25, 30 and 50 Cycles
 170 Watts, 60 Cycles 160 Watts
 Type of Circuit.....Super-Heterodyne using
 Super-Control Radiotrons and Push-pull Pen-
 tode output stage.
 Type and Number of Radiotrons... 2 RCA-235,
 3 UY-227, 1 UY-224, 1 UX-280, 2 RCA-247—
 Total, 9
 Number of Radio Frequency Stages.....1
 Type of First Detector..Tuned Input Grid Bias
 Number of Intermediate Stages.....1
 Type of Second Detector.....Power Grid Bias
 Type of Automatic Volume Control....UY-227
 Controlled by signal voltage in turn controlling
 bias on R. F. and I. F. tubes

Type of Manual Volume Control.....Potenti-
 ometer used to regulate input to second de-
 tector
 Type of Tone Control....Variable resistance in
 series with capacitor connected across grids of
 output stage. Capacitor tunes transformer at
 "low" position
 Number of Audio Stages (Radio).....1
 Number of Audio Stages (Phonograph).....2
 Type of Magnetic Pick-up.....Low Impedance
 Type of Tone Arm.....Inertia
 Diameter of Turntable.....12 inches
 Type of Rectifier.....Full Wave
 Type of Loudspeaker.....8" Electro-Dynamic
 Undistorted Output.....4.0 Watts

REPLACEMENT PARTS

Stock No.	DESCRIPTION	List Price	Stock No.	DESCRIPTION	List Price
RECEIVER ASSEMBLY					
2563	Resistor—6,000 ohms—Carbon type—1 watt—Pack- age of 5.....	\$3.00	3056	Shield—Radiotron shield—6 used—Package of 2....	\$0.50
2730	Resistor—18,000 ohms—Carbon type—1 watt— Package of 5.....	2.00	3076	Resistor—1 megohm—Carbon type—½ watt— Package of 5.....	2.50
2734	Capacitor—745 mmfd.—Package of 5.....	2.20	3077	Resistor—30,000 ohms—Carbon type—½ watt— Package of 5.....	2.50
2746	Socket—Dial lamp socket.....	.50	3078	Resistor—10,000 ohms—Carbon type—½ watt— Package of 5.....	2.50
2747	Cap—Grid contactor cap—Package of 5.....	.50	3079	Resistor—40,000 ohms—Carbon type—½ watt— Package of 5.....	2.50
2749	Capacitor—2400 mmfd.....	1.50	3085	Capacitor—400 mmfd.....	.60
2875	Knob—Tuning control, volume control or tone con- trol knob—Package of 5.....	1.50	3089	Board—Terminal board complete with 5 terminals...	.50
2882	Socket—Five contact Radiotron socket complete with insulator—8 used.....	.50	3091	Board—Resistor board complete less resistors and capacitors.....	1.00
2963	Resistor—8,000 ohms—Carbon type—1 watt— Package of 5.....	2.50	3092	Volume control—Volume control complete with mounting nut.....	1.50
2968	Socket—Four contact Radiotron socket complete with insulator—1 used.....	.50	3093	Tone control—Tone control complete with mounting nut.....	1.90
3024	Capacitor—9 mmfd.—Package of 2.....	.50	3095	Coil—R. F. coil.....	1.90
3046	Resistor—190,000 ohms—Carbon type—½ watt— Package of 5.....	2.50	3096	Coil—1st detector and oscillator coil complete with mounting bracket.....	3.55
3047	Resistor—1,500 ohms—Carbon type—½ watt— Package of 5.....	2.50	3098	Capacitor—0.008 mfd.....	.50
3048	Resistor—500,000 ohms—Carbon type—½ watt— Package of 5.....	2.50	3099	Capacitor—0.005 mfd.....	.75
3049	Resistor—150 ohms—Carbon type—½ watt—Pack- age of 5.....	2.50	6179	Terminal—Single ground terminal with screw com- plete with mounting rivet—Package of 5.....	.50
3050	Resistor—14,000 ohms—Carbon type—3 watt.....	.60	6188	Resistor—2 megohm—Carbon type—½ watt— Package of 5.....	2.00
3055	Cushion—Receiver chassis sponge rubber cushion— Package of 4.....	.50	6189	Bracket—Dial lamp bracket and indicator—Package of 2.....	.65
			6190	Shaft—Tuning dial shaft complete with 3 washers— —Package of 5.....	.85

R. C. A. VICTOR CO., INC.

MODEL RE-13-A
Parts List

REPLACEMENT PARTS—Continued

Stock No.	DESCRIPTION	List Price	Stock No.	DESCRIPTION	List Price			
RECEIVER ASSEMBLY—Continued								
6191	Cord—Condenser drum drive cord—Package of 5 . . .	\$0.55	6119	Stud—Motor hanging stud—Package of 6	\$0.50			
6192	Spring—Condenser drum drive cord tension spring— Package of 1050	6120	Screw—For holding turntable spindle bearing and grease cap—Package of 1050			
7054	Cord—Power cord	1.00	6121	Bearing—Turntable spindle bearing and grease cap . .	1.10			
7062	Capacitor—Adjustable capacitor—15-70 mmfd.	1.00	6215	Escutcheon—Shift lever speed escutcheon plate with mounting screws—Package of 270			
7266	Transformer—1st intermediate transformer	3.00	6216	Rod—Automatic brake trip rod with nut—Package of 550			
7267	Transformer—2nd intermediate transformer	3.00	6221	Cover—Pickup cover75			
7268	Coil—Detector choke coil complete with mounting rivet60	6222	Pickup—Pickup unit complete	12.50			
7269	Capacitor—Comprising one 2.0 mfd., one 4.0 mfd., four 0.5 mfd., two 1.0 mfd., five 0.1 mfd. and one 0.05 mfd. capacitor in metal container	7.25	6224	Receptacle—Tungstone needle box holder75			
7270	Reactor—Filter reactor	4.00	6232	Box—Needle box with lid—Package of 290			
7271	Transformer—Interstage transformer	4.25	6237	Holder—Twin needle holder with mounting screws . .	.75			
7272	Transformer—Power transformer—105-125 volts, 50-60 cycles	12.00	6238	Transformer—Input transformer	3.10			
7273	Capacitor—Comprising one 4.0 mfd., one 6.0 mfd., four 0.5 mfd., two 1.0 mfd., five 0.1 mfd., and one 0.05 mfd. capacitors in metal container	10.00	7084	Cover—Turntable cover50			
7274	Transformer—Power transformer—105-125 volts— 25-40 cycles	15.00	7151	Back—Pickup housing back50			
7275	Transformer—Power transformer—220 volts—50-60 cycles	10.00	7305	Gear—Gear reducing unit complete	4.50			
7438	Capacitor—Variable tuning capacitor	5.20	7332	Cable—Main cable from receiver to input transform- er, volume control and radio record switch	2.30			
7439	Drum—Tuning condenser drive drum with set screw —Complete with 3 dial scale mounting nuts50	7387	Reactor—Tone compensating reactor with bracket . .	.85			
7440	Scale—Dial and dial scale75	7388	Spindle—Turntable spindle with fibre gear—110 volts or 220 volts—60 cycles	6.00			
8871	Support—Receiver chassis metal mounting support —Package of 475	7389	Rotor and shaft—110 volts or 220 volts—60 cycles . .	9.00			
LOUDSPEAKER ASSEMBLY								
3237	Speaker mounting screw assembly—Comprising 4 screws, 8 washers, 8 nuts and 4 eyelets—Package of 1 set50	7390	Motor mounting washer and springs—Comprising 3 "C" washers, 9 cup washers and 6 springs—Pack- age of 1 set75			
7257	Coil assembly—Comprising field coil, cone bracket and magnet	6.00	7391	Volume control—Record volume control complete with mounting nut and washer	1.35			
8559	Ring—Cone retaining ring80	7393	Block—Pickup connector block and wire90			
8601	Cone—Speaker paper cone—Package of 5	15.00	7400	Spindle—Turntable spindle with fibre gear—25 cycles .	8.00			
MOTOR BOARD ASSEMBLY								
X-13	Board—Motor board less equipment	5.85	7401	Rotor and shaft—25 cycles	10.00			
2614	Switch—Automatic brake switch	1.40	7402	Spindle—Turntable spindle with fibre gear—30 cycles .	8.00			
2620	Cushion—Pickup rubber cushions—Comprising 1 damper and two pivot cushions—Package of 5 sets . .	1.25	7403	Rotor and shaft—30 cycles	10.00			
2767	Spring—Pickup magnet retaining spring—Package of 1050	7443	Rotor and shaft—110 volts or 220 volts—50 cycles . .	9.00			
2768	Armature—Pickup armature50	7444	Spindle—Turntable spindle with fibre gear—110 volts or 220 volts—50 cycles	6.00			
2770	Plate—Pickup damper plate—Package of 550	8795	Motor—Motor complete—110 volts—60 cycles	19.85			
2771	Screw—Pickup damper plate mounting screw— Package of 1050	8800	Motor—Motor complete—110 volts—25 cycles	24.65			
2875	Knob—Volume control and record-radio switch knob —Package of 5	1.50	8801	Motor—Motor complete—110 volts—30 cycles	24.65			
2908	Spring—Pawl carrier spring—Package of 1050	8856	Motor—Motor complete—110 volts—50 cycles	19.85			
3052	Screw assembly—Pickup pole shoe mounting screw assembly—Comprising screw, nut and washer— Package of 10 sets50	8872	Lever—Shift lever complete with mounting screws . .	1.60			
3157	Gear—Driving gear—Located on turntable spindle above top plate	1.00	8873	Brake—Automatic brake complete with mounting screws and washers	3.50			
3159	Friction brake—Gear reducing friction brake spring with pad—Complete with mounting rivet—Pack- age of 4	2.00	8876	Support—Lid support	2.00			
3161	Spring—Shift lever spring—Package of 5	1.20	8877	Turntable—Turntable with cover	4.60			
3167	Magnet—Pickup magnet	2.60	8880	Arm—Pickup arm complete less pickup unit	6.00			
3169	Pole shoe—Pickup pole shoe—R. H.	1.45	8887	Motor—Motor complete—220 volts—60 cycles	19.85			
3170	Pole shoe—Pickup pole shoe—L. H.	1.45	8888	Motor—Motor complete—220 volts—50 cycles	19.85			
3205	Screw—Pickup needle holding screw—Package of 10 .	.80	10174	Springs—Automatic brake springs—Set of 4 springs —Package of 2 sets50			
3207	Screw—Pickup cover mounting screw—Package of 10 .	.50	10184	Plate—Automatic brake trip plate complete with screws—Package of 560			
3208	Screw assembly—Pickup mounting screw assembly —Comprising screw, nut and washer—Package of 1060	CABINET ASSEMBLY					
3211	Washer—Turntable spindle leather washer—Pack- age of 1050	X-14	Board—Baffle board and grille cloth	1.30			
3224	Switch—Record-Radio switch complete with mount- ing nut and washer	1.35	X-16	Stretcher	4.70			
3278	Bearing—Rotor shaft fibre thrust bearing and cork button—Package of 1050	X-17	Foot	1.00			
3279	Screw and nut—Rotor shaft thrust bearing adjusting screw and nut—Package of 1050	X-18	Leg	3.55			
3280	Washer—Metal washer—Located on turntable spindle underneath gear reducing unit—Package of 2050	X-19	Lid	12.00			
3281	Pawl—Gear reducing pawl with mounting stud50	X-21	Overlay—Front top rail end overlay—R. H. or L. H. .	1.25			
			X-22	Overlay—Front top rail center overlay	2.65			
			X-23	Mouldings—Control panel mouldings—Package of 1 set	1.60			
			X-85	Escutcheon—Tuning dial escutcheon	1.15			
			X-86	Panel—Control panel	6.90			
			X-87	Doors—R. H. and L. H. doors complete less door pulls and hinges—Package of 1 set	8.00			
			X-88	Mouldings—Door mouldings for R. H. and L. H. doors—Package of 1 set	3.00			
			2776	Catch—Door catch and strike with nail—Package of 2 sets50			
			3156	Label—Metal trade mark label—Package of 5	2.50			
			6210	Hinge assembly—Door hinge assembly—Comprising 4 hinges and 16 mounting screws—Package of 1 set .	.90			
			6211	Pull—Door pull with mounting screw—Package of 4 .	1.20			
			6219	Hinge—Cabinet lid hinge complete with mounting screws—Package of 250			
			6236	Support—Metal screen support50			
			9410	Cabinet—Cabinet complete less equipment	83.00			
			10901	Spring—Lid support spring—Package of 250			

MODEL RE-19 AC (AVC)
Schematic
Chassis

R. C. A. VICTOR CO., INC.

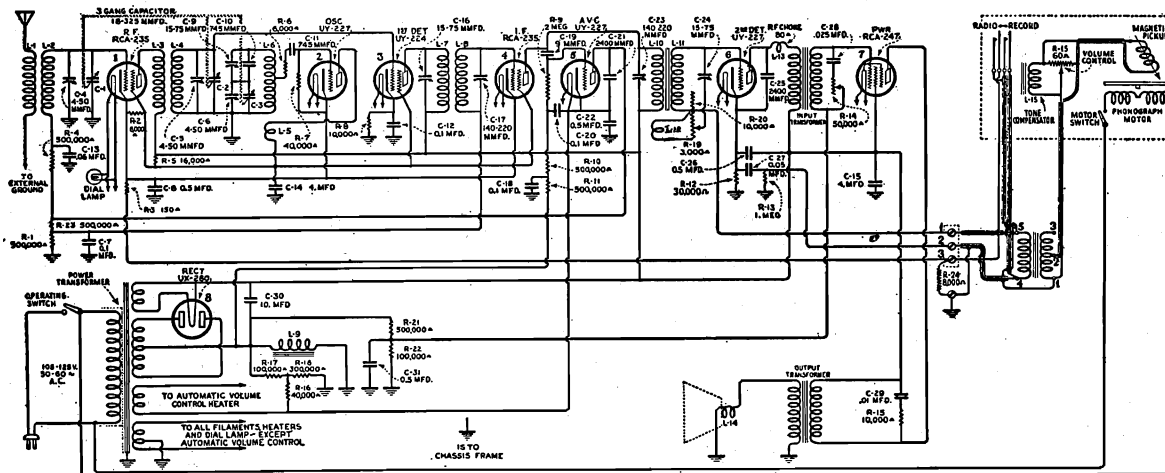

Schematic Circuit

Models RE-19 (1932)

IF PEAK 175 KC.

Voltage Rating.....105-125 Volts
Frequency Rating.....25, 30, 50 or 60 Cycles
Power Consumption.....25 ~ 135 Watts, 30 ~ 140 Watts, 50 ~ 135 Watts, 60 ~ 130 Watts

1 DET	IF	A.V.C.	AF
'24A	'35	'27	'47
OSC	RF	2 DET	RECT
'27	'35	'27	'80

FRONT

RCA Victor RE-19 is an eight tube Super-Heterodyne combination radio receiver and electric phonograph. The chassis used is similar to the R-12 with the exception that terminals for attaching a magnetic pickup are provided. The motor board assembly is similar to the RE-18. Reference to previous RCA Victor Service Notes should be made for service information relative to these assemblies. The replacement parts are given below and the diagrams on the following pages.

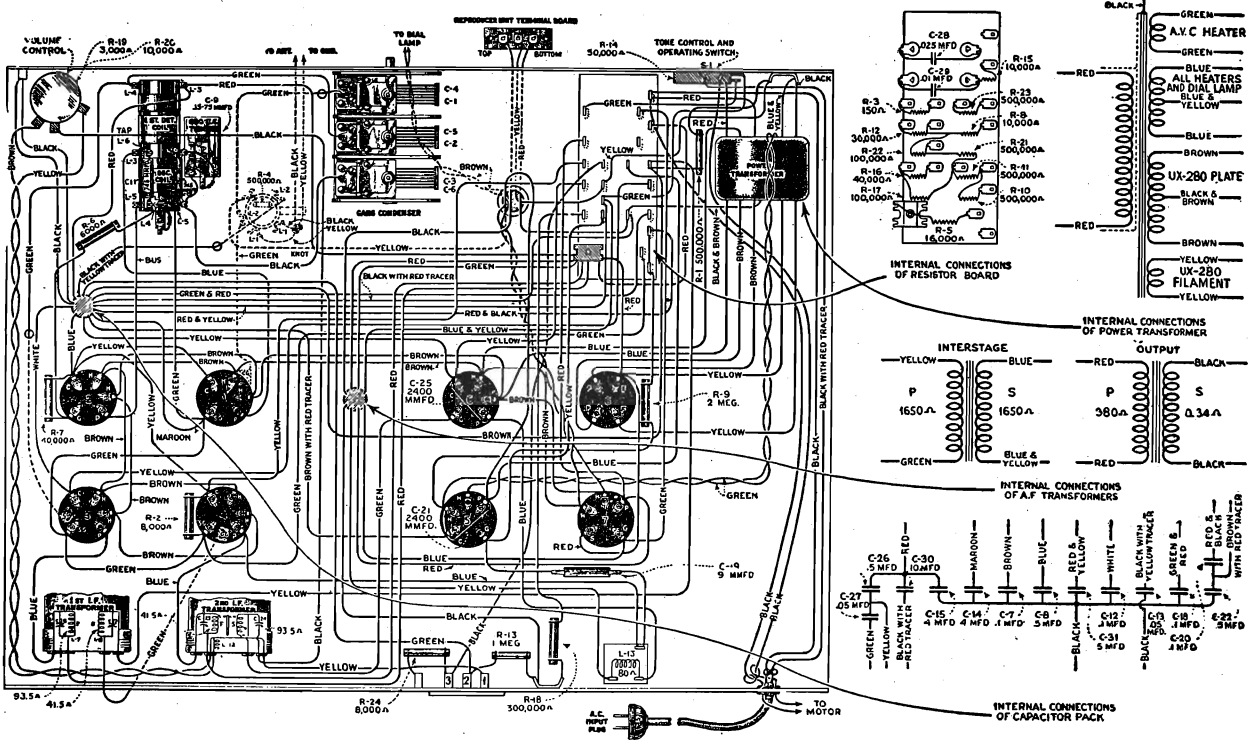

MODEL RE-20 Electrola
Chassis - Parts List

R. C. A. - VICTOR CO. INC.

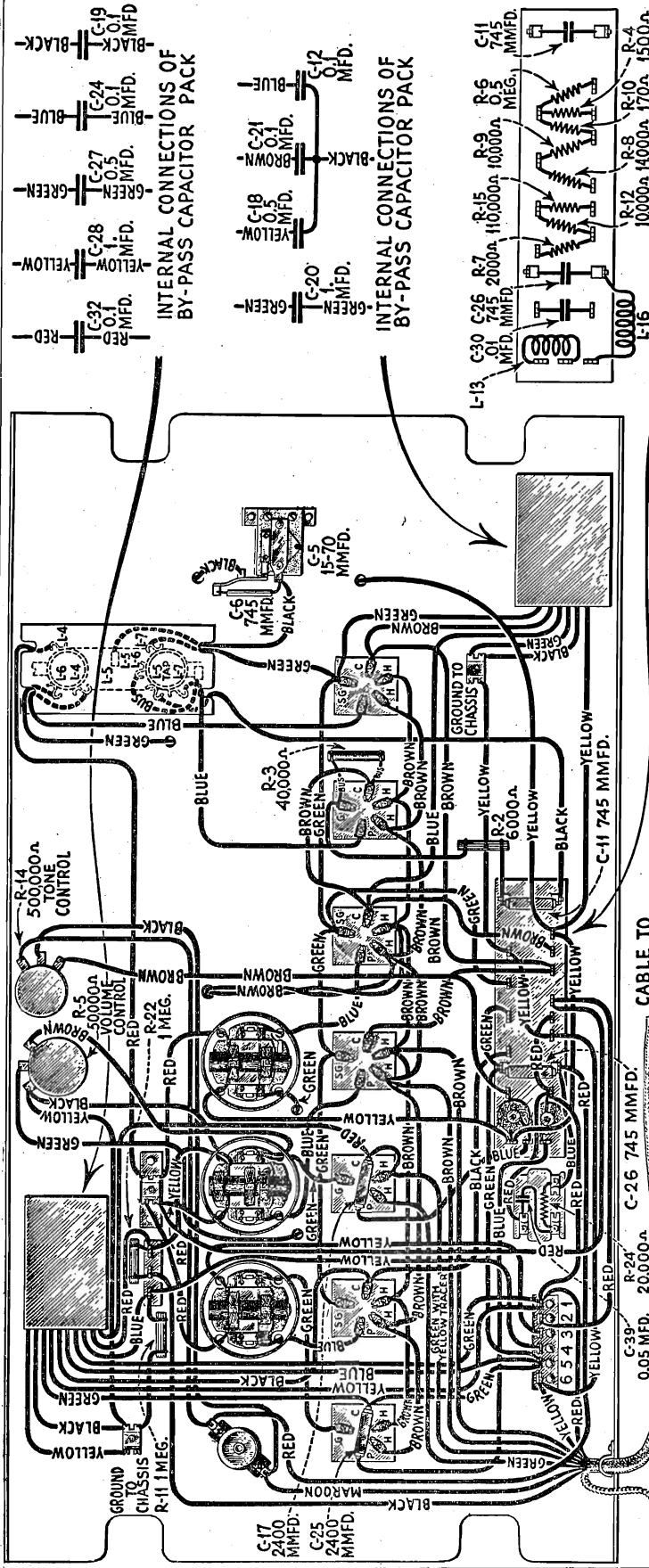

Receiver Assembly Wiring Diagram

Stock No.	DESCRIPTION	List Price	Quantity
2563	RECEIVER ASSEMBLY		
2726	Resistor—6,000 ohms—Carbon type—1 watt—Package of 5	\$3.00	2.75
2731	Socket—Five contact Radiotron socket—Complete with insulator—7 used	.70	2.75
2732	Resistor—10,000 ohms—Carbon type—1 watt—Package of 5	2.00	2.75
2736	Resistor—110,000 ohms—Carbon type—1 watt—Package of 5	2.00	2.00
2749	Resistor—170 ohms—Carbon type—1 watt—Package of 5	2.00	1.10
2970	Capacitor—2400 mmfd.	1.50	1.00
3031	Resistor—500,000 ohms—Carbon type—1 watt—Package of 5	2.50	1.00
3033	Board—Terminal board complete with insulator—Three terminals	.50	2.50
3045	Resistor—1 megohm—Carbon type—1/4 watt—Package of 5	2.00	3.50
3050	Resistor—40,000 ohms—Carbon type—1 watt—Package of 5	2.50	4.50
3058	Resistor—14,000 ohms—Carbon type—3 watt	.60	.80
3153	Resistor—1500 ohms—Carbon type—1 watt—Package of 5		.70
3154	Resistor—2,000 ohms—Carbon type—1 watt—Package of 5		2.00
3220	Resistor—15 ohms—Flexible wire type—Package of 5		2.00
6114	Resistor—20,000 ohms—Carbon type—1 watt—Package of 5		1.00
6220	Capacitor—0.05 mfd.—Package of 5		1.00
7062	Capacitor—Adjustable capacitor—15-70 mmfd.—2 used		2.50
7063	Capacitor—Adjustable capacitor 5-40 mmfd.—3 used		3.50
7278	Coil—R. F. and link circuit coil		4.50
7285	Capacitor pack—Comprising one 1.0 mfd., one 0.5 mfd., and two 0.1 mfd. capacitors in metal container—6 leads		.80
7286	Capacitor pack—Comprising one 1.0 mfd., one 0.5 mfd., and three 0.1 mfd. capacitors in metal container—10 leads		.70
7298	Capacitor—0.01 mfd.		
7299	Capacitor—745 mfd.		

R. C. A. VICTOR CO., INC.

MODEL RE-20 Electrola Schematic

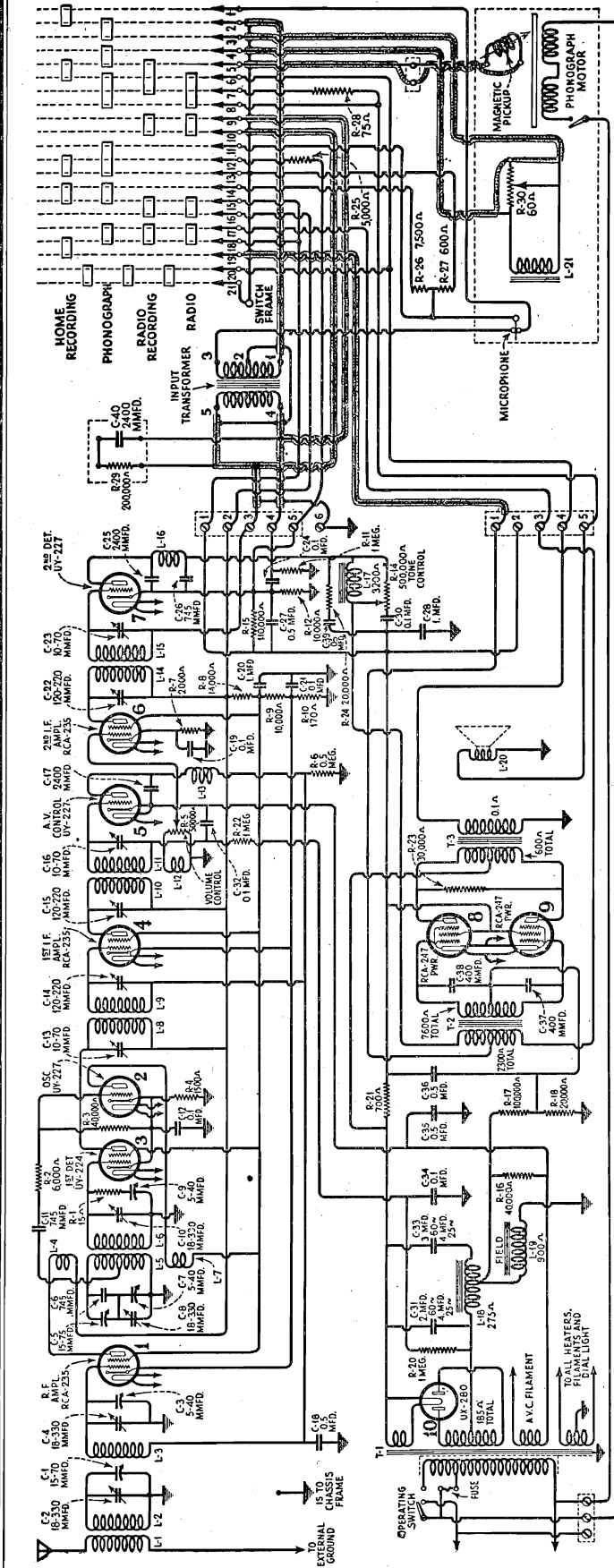

IF PEAK 175 KC.

Schematic Circuit

RCA Victor RE-20 is a ten tube De Luxe Super-Heterodyne combination radio receiver and electric phonograph. Except for the differences in cabinet and omission of the automatic record changing mechanism, the RE-20 is similar to the RAE-59.

Service work in conjunction with this model is similar to that of the R-50, R-55 and RAE-59. Reference to these Service Notes should therefore be made when such information is necessary. The replacement parts and the diagrams are given on the following pages.

Voltage Rating.....	105-125 Volts
Frequency Rating.....	25, 30, 50 and 60 Cycles
Power Consumption (Radio only).....	145 Watts
Power Consumption (Phonograph).....	160 Watts (Approximately)
Type of Circuit.....	A. V. C. Super-Heterodyne with Push-pull Pentode Output Stage
Type and Number of Radiotrons.....	3 RCA-235, 1 UY-224, 3 UY-227, 2 RCA-247, 1 UX-280--Total 10
Wattage Dissipation in Loudspeaker Field.....	10 Watts
Undistorted Output.....	4.0 Watts

Model RE-20, (1932)

2 DET IF	AV.C.	IF	1 DET	OSC	RF
○	○	○	○	○	○
'27	'35	'27	'35	'24A	'27
RECEIVER					
PILOT NO. 41 MAZDA					

RECT					
○					
'80					
RECTIFIER, AMPLIFIER					
FRONT					

MODEL RE-20 Electrola
Assembly Wiring

R. C. A. VICTOR CO., INC.

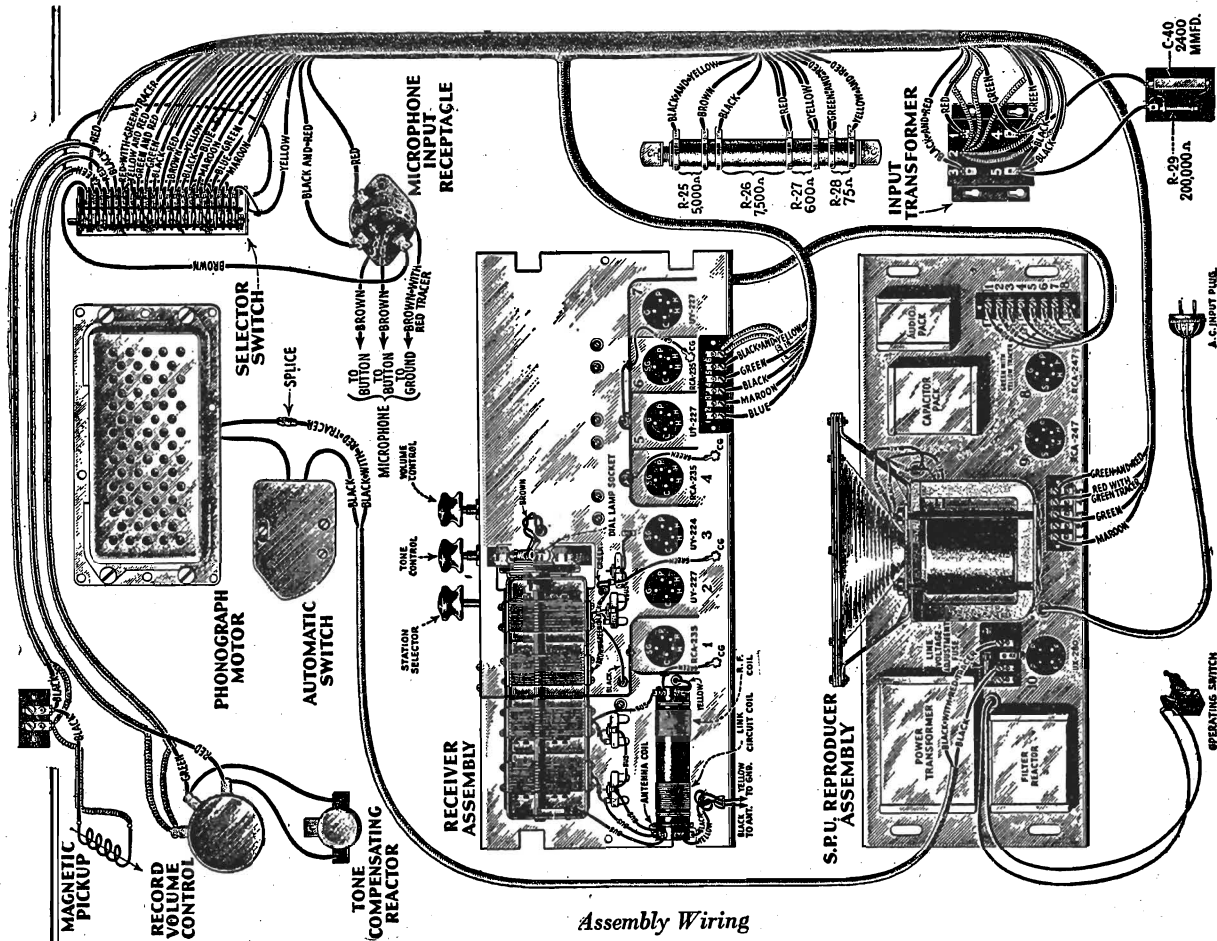

- Type of Magnetic Pickup..... Low Impedance
- Type of Tone Arm..... Inertia
- Diameter of Turntable..... 12 inches
- Type of Phonograph Motor..... Induction, running at synchronous speed
- Turntable Speed..... 78 and 33 1/2 R. P. M.

LOUDSPEAKER ASSEMBLY	
7292	Screw assembly—Speaker mounting screw assembly—Comprising two screws, two nuts, two washers and one plate—Package of 1 set..... .95
8558	Cone—Speaker paper cone..... 4.00
8559	Ring—Cone retaining ring..... .80
8713	Coil—Speaker field coil..... 5.00
MOTOR BOARD AND MISCELLANEOUS ASSEMBLIES	
2749	Capacitor—2400 mmfd..... 1.50
7327	Mechanism—Microphone mechanism complete with cord..... 14.95
7375	Resistor—13175 ohms tapped porcelain resistor..... 2.10
7387	Reactor—Tone compensating reactor complete with mounting bracket..... .85
7388	Spindle—Turntable spindle with fibre gear—110 volts or 220 volts—60 cycles..... 6.00
7389	Rotor and shaft—110 volts or 220 volts—60 cycles..... 9.00
6226	Transformer—Phono input transformer..... 3.75
6228	Resistor—200,000 ohms—Carbon type—1/2 watt—Package of 5..... 2.50
6227	Resistor board assembly—Comprising one 200,000 ohms—Carbon type—1/2 watt resistor and one 2400 mmfd. tooth pick capacitor on board..... 1.35
6229	Cable—30' shielded red cable from selector switch to volume control—Package of 2..... .70
6230	Cable—30' shielded green cable from selector switch to volume control—Package of 2..... .70
6231	Cable—18' shielded black cable from selector switch to pickup terminal board—Package of 2..... .60
7400	Spindle—Turntable spindle with fibre gear—25 cycles..... 8.00
7401	Rotor and shaft—25 cycles..... 10.00
7443	Rotor and shaft—110 volts or 220 volts—50 cycles..... 9.00
7444	Spindle—Turntable spindle with fibre gear—110 volts or 220 volts—50 cycles..... 6.00
8795	Motor—Motor complete—110 volts—60 cycles..... 19.85
8800	Motor—Motor complete—110 volts—25 cycles..... 24.65
8856	Motor—Motor complete—110 volts—50 cycles..... 19.85
8887	Motor—Motor complete—220 volts—60 cycles..... 19.85
8888	Motor—Motor complete—220 volts—50 cycles..... 19.85

MODEL R-21
Schematic
Changes

R. C. A. - VICTOR CO., INC.

Voltage Rating.....105-125 Volts
Frequency Rating.....50-60 Cycles and
25-40 Cycles
Power Consumption.....25-40 Cycles 140 Watts,
50-60 Cycles 135 Watts

REPLACEMENT PARTS (Continued)	
3099	Capacitor—.0005 mfd.....
3137	Knob—Tuning control, volume control and tone control knob—Package of 5.....
6179	Terminal—Single ground terminal with five—Package of 5.....
6186	Resistor—500,000 Ohms—Carbon type— $\frac{1}{4}$ Watt—Package of 5.....
6188	Resistor—2 Megohms—Carbon type— $\frac{1}{4}$ Watt—Package of 5.....
6189	Bracket—Dial lamp bracket and indicator—Package of 2.....
6190	Shaft—Tuning condenser, drive shaft complete with 3 washers—Package of 5.....
6191	Cord—Tuning condenser drive cord—Package of 5.....
6192	Spring—Tuning condenser drive cord tension spring—Package of 10.....
7064	Coil—Power cord.....
7062	Capacitor—Adjustable capacitor—15-70 mmfd.....
7266	Transformer—2nd intermediate transformer.....
7267	Transformer—1st intermediate transformer.....
7268	Coil—Choke coil.....
7269	Capacitor—Compensating one 2.0 mfd, one 4.0 mfd, four 0.5 mfd, two 1.0 mfd, five 0.1 mfd, and one 0.05 mfd, capacitors in metal container.....
7270	Reactor—Filter reactor.....
7271	Transformer—Intermediate transformer.....
7272	Transformer—Power transformer.....
7273	Capacitor—Compensating one 4.0 mfd, one 6.0 mfd, four 0.5 mfd, two 1.0 mfd, five 0.1 mfd, and one 0.05 mfd, capacitors in metal container—105-125 volts, 25-40 cycles.....
7274	Transformer—Power transformer—105-125 volts, 25-40 cycles.....
7275	Transformer—Power transformer—220 Volts, 60 cycles.....
7438	Capacitor—Variable tuning capacitor.....
4.25	Transformer—Intermediate transformer.....
\$12.00	Transformer—Power transformer.....
10.00	Capacitor—Compensating one 4.0 mfd, one 6.0 mfd, four 0.5 mfd, two 1.0 mfd, five 0.1 mfd, and one 0.05 mfd, capacitors in metal container—105-125 volts, 25-40 cycles.....
15.00	Transformer—Power transformer—105-125 volts, 25-40 cycles.....
30.00	Transformer—Power transformer—220 Volts, 60 cycles.....
5.20	Capacitor—Variable tuning capacitor.....

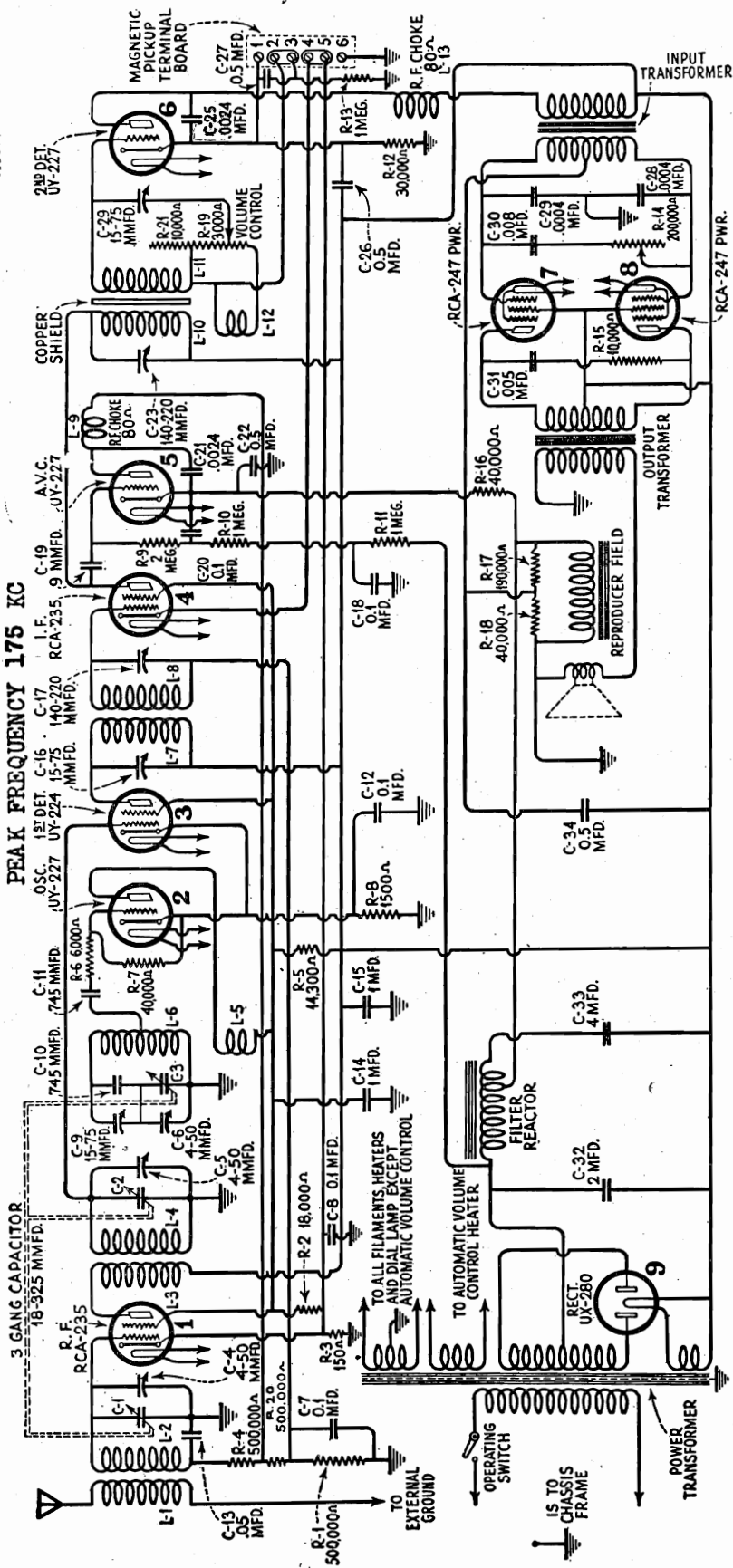

The chassis and loudspeaker used in Model R-21 is identical with that used in the R-11 except for the dial and scale. A reference to the R-11 Service Notes will therefore give any information necessary in reference to circuit diagram, voltage reading and other service information. One change should be noted in later production of R-11s and all R-21s and that is the change in value of Resistor R-9 from 5 Megohms to 2 Megohms.

R. C. A. VICTOR CO., INC.

MODEL RE-21
Chassis

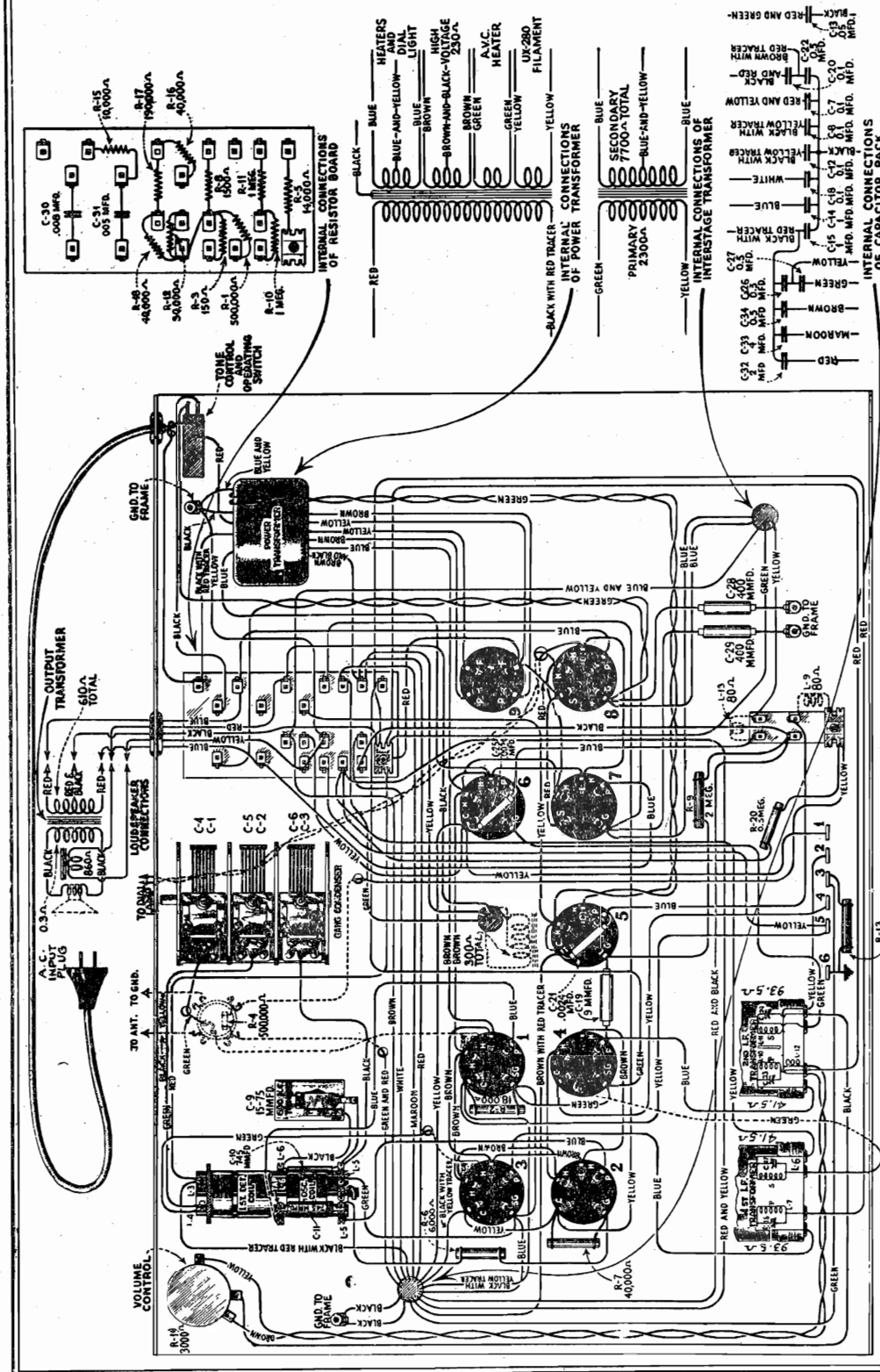

REPLACEMENT PARTS

2553	Resistor—6,000 Ohms—Carbon type—1 Watt—Package of 5	\$3.00
2730	Resistor—18,000 Ohms—Carbon type—1 Watt—Package of 5	2.00
2734	Capacitor—745 mfd.—Package of 5	2.20
2746	Socket—Dial lamp socket	.50
2747	Cap-Grid condenser cap—Package of 5	1.50
2749	Capacitor—2400 mfd.—Package of 5	.50
2882	Socket—5 contact Radiotron socket—Complete with insulator—1 used	.50
2968	Resistor—190,000 Ohms—Carbon type—1/2 Watt—Package of 5	\$2.50
3046	Resistor—1,500 Ohms—Carbon type—1/2 Watt—Package of 5	2.50
3047	Resistor—500,000 Ohms—Carbon type—1/2 Watt—Package of 5	2.50
3048	Resistor—150 Ohms—Carbon type—1/2 Watt—Package of 5	2.50
3049	Resistor—14,000 Ohms—Carbon type—1/2 Watt—Package of 5	.60
3050	Capacitor—9 mfd.—Package of 2	.50
3053	Cushion—Receiver chassis sponge rubber—Package of 4	.50
3055	Shield—Radio shield—6 used	\$0.50
3056	Package of 2	2.50
3076	Resistor—1 Megohm—Carbon type—1/2 Watt—Package of 5	2.50
3077	Resistor—30,000 Ohms—Carbon type—1/2 Watt—Package of 5	2.50
3078	Resistor—10,000 Ohms—Carbon type—1/2 Watt—Package of 5	2.50
3079	Resistor—40,000 Ohms—Carbon type—1/2 Watt—Package of 5	2.50
3085	Capacitor—400 mfd.	.60
3089	Board—Magnetic pickup terminal board—Complete with mounting	.50
3090	Board—A.V.C. and 2nd detector R.F. choke board—Less choke coils	.50
3091	Board—Resistor board complete less resistors and capacitors	1.00
3092	Volume Control—Volume control complete with mounting nut	1.50
3093	Tone Control—Tone control complete with mounting nut	1.90
3095	Coil—R.F. coil	1.90
3096	Coil—1st detector and oscillator coil	3.55
3098	Capacitor—0.008 mfd.	.50

MODEL R-21
Resistance Data

R. C. A. - VICTOR CO., INC.

All tubes removed from sockets and AC plug removed from power supply.
Pick up and field coil disconnected

From Chassis To
Aerial to ground post
Chassis to

2 Det Control Grid(Pickup Board Ter #2) 93.5 ohms
2 Det Control Grid to V.C. Arm 3,093.5-10,093.5 ohms
2 Det Cathode 30,000 ohms
Pickup Board Terminal 2 1,000,000 ohms
2 Detector Plate 34,830 ohms

From Chassis To
2 Detector Plate-'80 Fil 2,380 ohms
'47 Control Grid 43,850 ohms
'47 Control Grid to Control Grid 7,700 ohms
'47 Screen 32,450 ohms
'47 Screen - '80 Fil 0 ohms
'47 Plate 32,765 ohms
'47 Plate to Plate 610 ohms
80 Anode to chassis 230,400 ohms
80 Anode to Anode 230 ohms
80 Fil to chassis 32,450 ohms
Across Speaker field 860 ohms

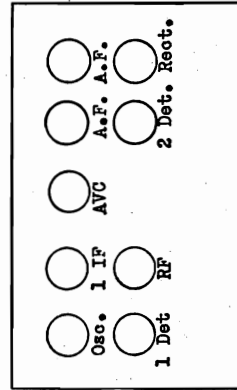

Correct
40 ohms

Correct
Incorrect

RF Control Grid(early model)1,000,005 ohms BLC- in tuned circuit (.1 mfd) TC-Y
RF Control Grid(late model) 1,500,005 ohms BLC- in tuned circuit(.05 mfd) BC-AVC ohk-Y
RF Cathode 150 ohms BC- rf K-Y (.1 mfd) BC-1 IF Tr. Sec -Y
RF Screen Grid 18,150 ohms BC- rf Sg- Y (.1. mfd) BC- rf K-Y (.1 mfd)
RF Plate 32,508 ohms BC-'80 P- Spkr div. tap BC-'47 Sg-Y (.5 mfd)
RF Plate to '80 Fil 58 ohms BC- rf P-Y (.1. mfd) BC-'80 P- Spkr div. tap
1 Detector Control Grid 1,500 ohms See RF Screen Grid
1 Detector Cathode 18,150 ohms TC- Y
1 Detector Screen 32,541.5 ohms BC-Y (.1 mfd)
1 Detector Plate 93.5 ohms See R-F Screen
1 Detector Plate to '80 Fil 41,500 ohms See R-f Plate
Oscillator Control Grid 1,500 ohms BLC-Osc.Grid.Chr.(.0074)
Oscillator Cathode 18,151 ohms BC-Osc K-Y (.1 mfd)
Osc Plate and Det Screen 1 ohm See R-F Screen
IF Control Grid (all models) 500,041.5 ohms BC-Y (.5 mfd)
IF Screen Grid 18,150 ohms TC-1 IF Tr Sec
IF Plate 32,491.5 ohms See RF Screen
IF Plate - '80 Fil 41.5 ohms See 1 Detector Plate
AVC Control Grid (early) 7,230,285 ohms BLC- if P- AVC Cg(9umfd)
AVC Control Grid (late) 4,230,285 ohms BC-5 meg - AVC H(.1 mfd)
AVC Cathode 270,000 ohms FC-'80 Anode-80 F(2mfd)
AVC Plate 1,000,085 ohms FC filter ohk-80 F(.5mfd)
AVC Plate 1,000,085 ohms BC-AVC K-Y (.5 mfd)
AVC Cathode 270,000 ohms BC-Spkr div.tap -Y
AVC Plate 1,000,085 ohms BC-AVC K-AVC P
AVC Cathode 270,000 ohms BC-AVC K-Y
AVC Plate 1,000,085 ohms BC-AVC P-AVC K
AVC Control Grid (early) 7,230,285 ohms See RF Control Grid

Line Voltage 110. Volume Control does not change voltages.

Tube	Cathode- Heater	Control Grid- Cathode	Screen Grid- Cathode	Plate- Cathode	Filament- Current	Filament- Voltage
RF	2.	0.1*	75.	205.	5.0 ma	2.2
Osc.	8.	0.	-	60	5.0	2.2
1 Det.	7.	7.0	70	200.	0.5	2.2
IF	2.	0.1*	75	205.	5.0	2.2
AVC	0.	0.	-	25.	-	2.2
2 Det.	20.	8.0*	-	180.	0.5	2.2
Pwr	-	-	210	205.	25.	2.2
Pwr	-	10.	210	205.	25.	2.2

* Not true reading due to resistance in the circuit

R. C. A. VICTOR CO., INC.

MODEL RO-23
Schematic

Models R-23, RO-23 (1931)

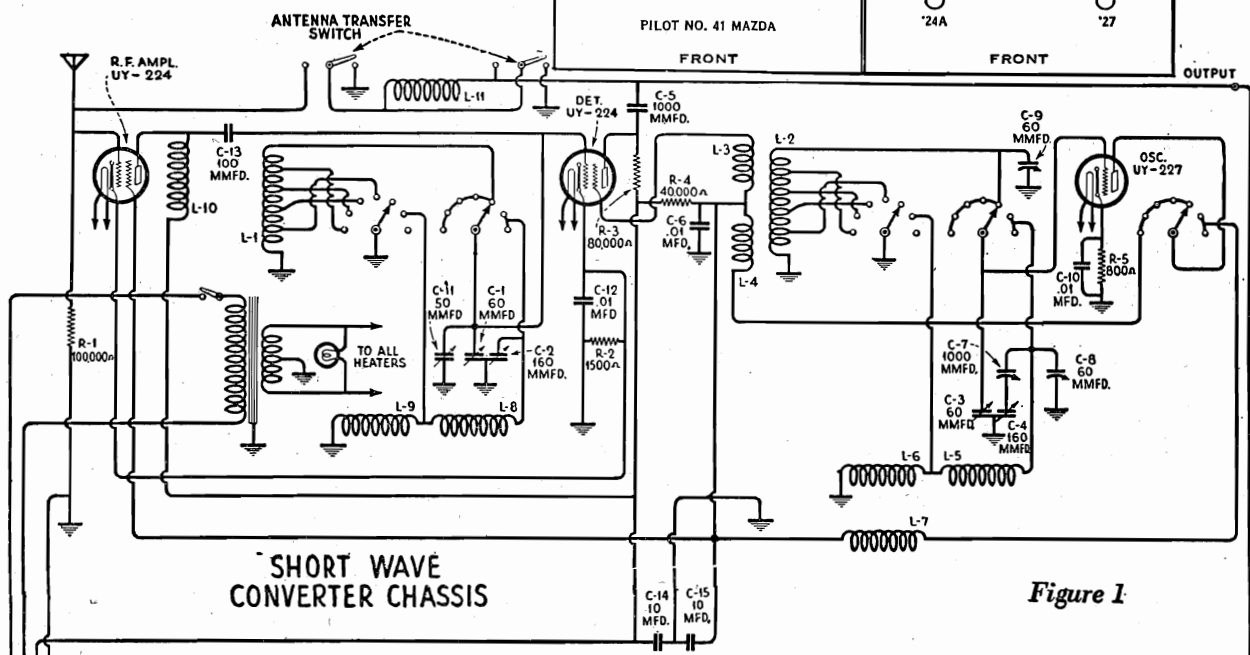
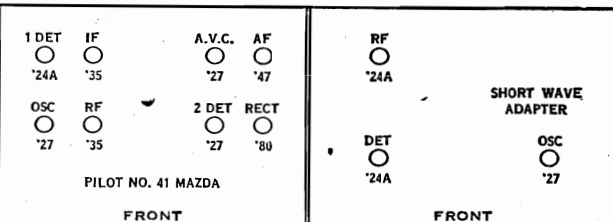

BROADCAST RECEIVER INTERMEDIATE FREQUENCY 175 KC
CONVERTER INTERMEDIATE FREQUENCY 1075 KC

Note—On some models operating switch for broadcast receiver is in circuit to Converter.

BROADCAST RECEIVER CHASSIS

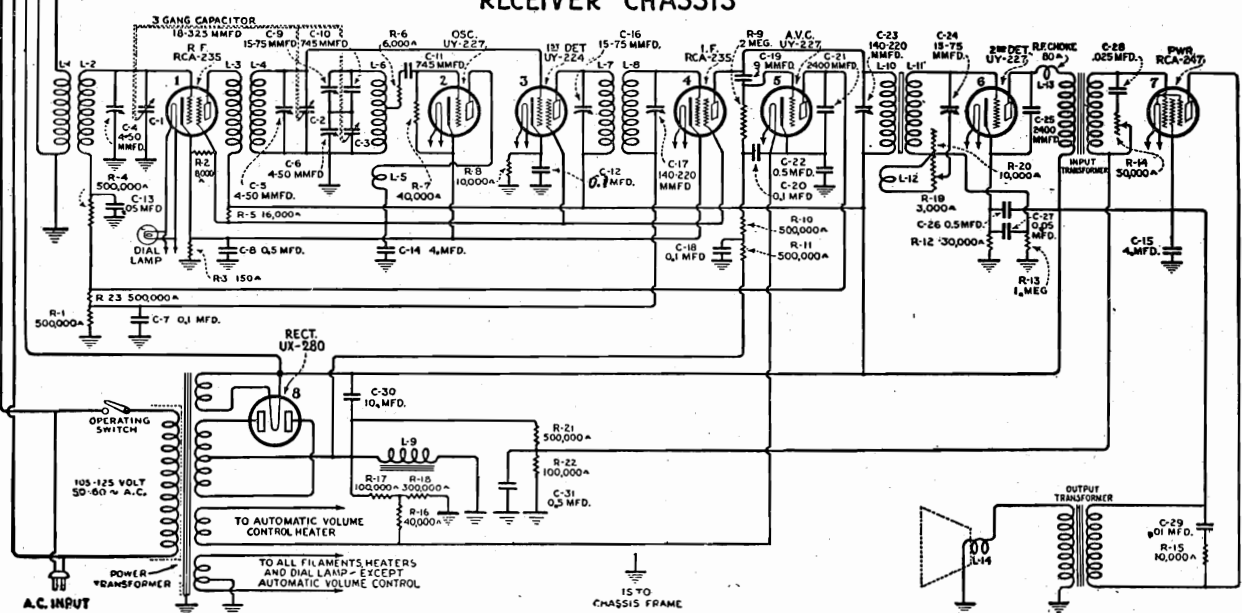

Voltage Rating 105-125 Volts and 200-250 Volts
Frequency Rating 50-60 cycles and 25-40 cycles
Power Consumption 120 Watts

MODEL RO-23
Broadcast Chassis

R. C. A. - VICTOR CO., INC.

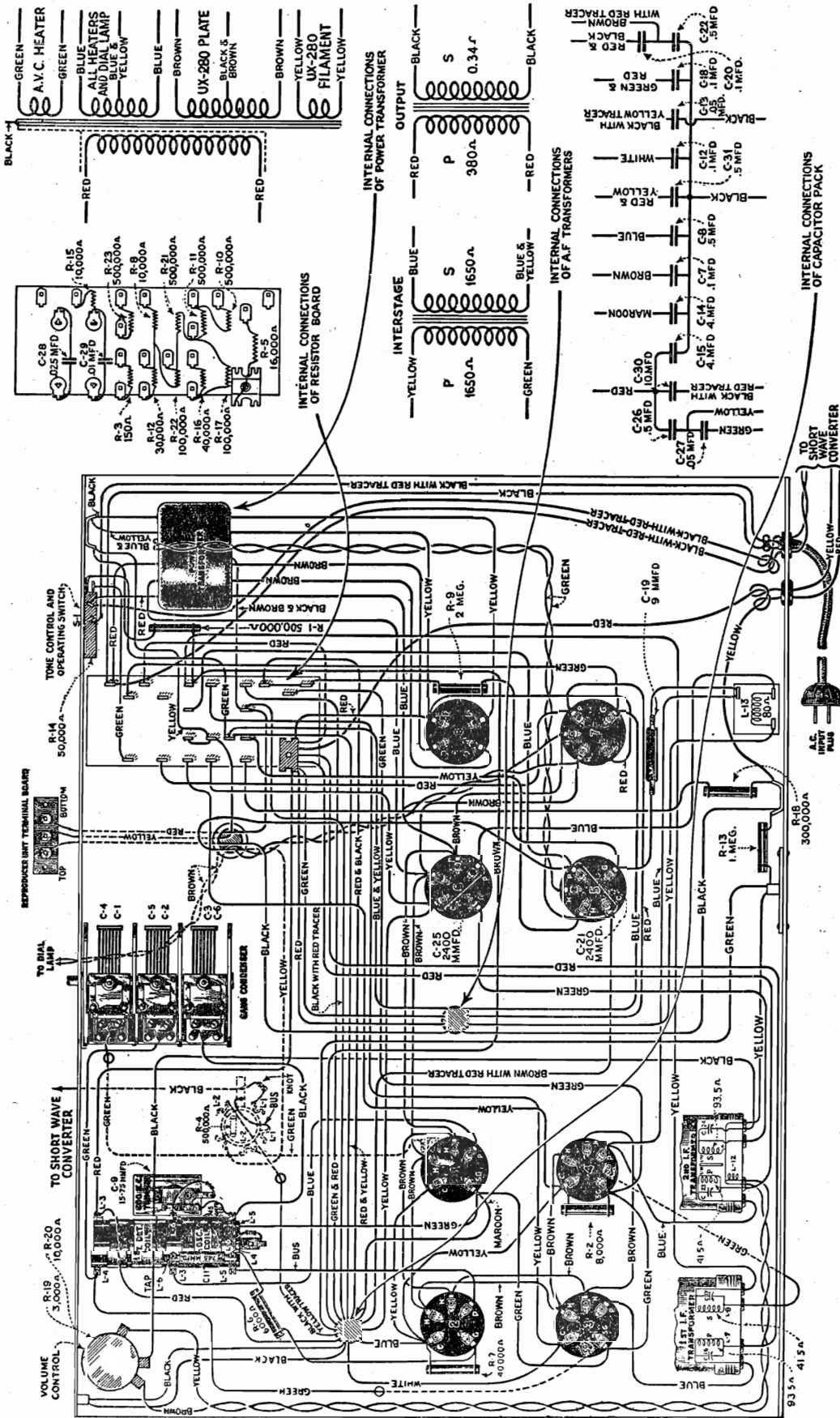

R. C. A. VICTOR CO., INC.

MODEL RO-23
Converter Chassis

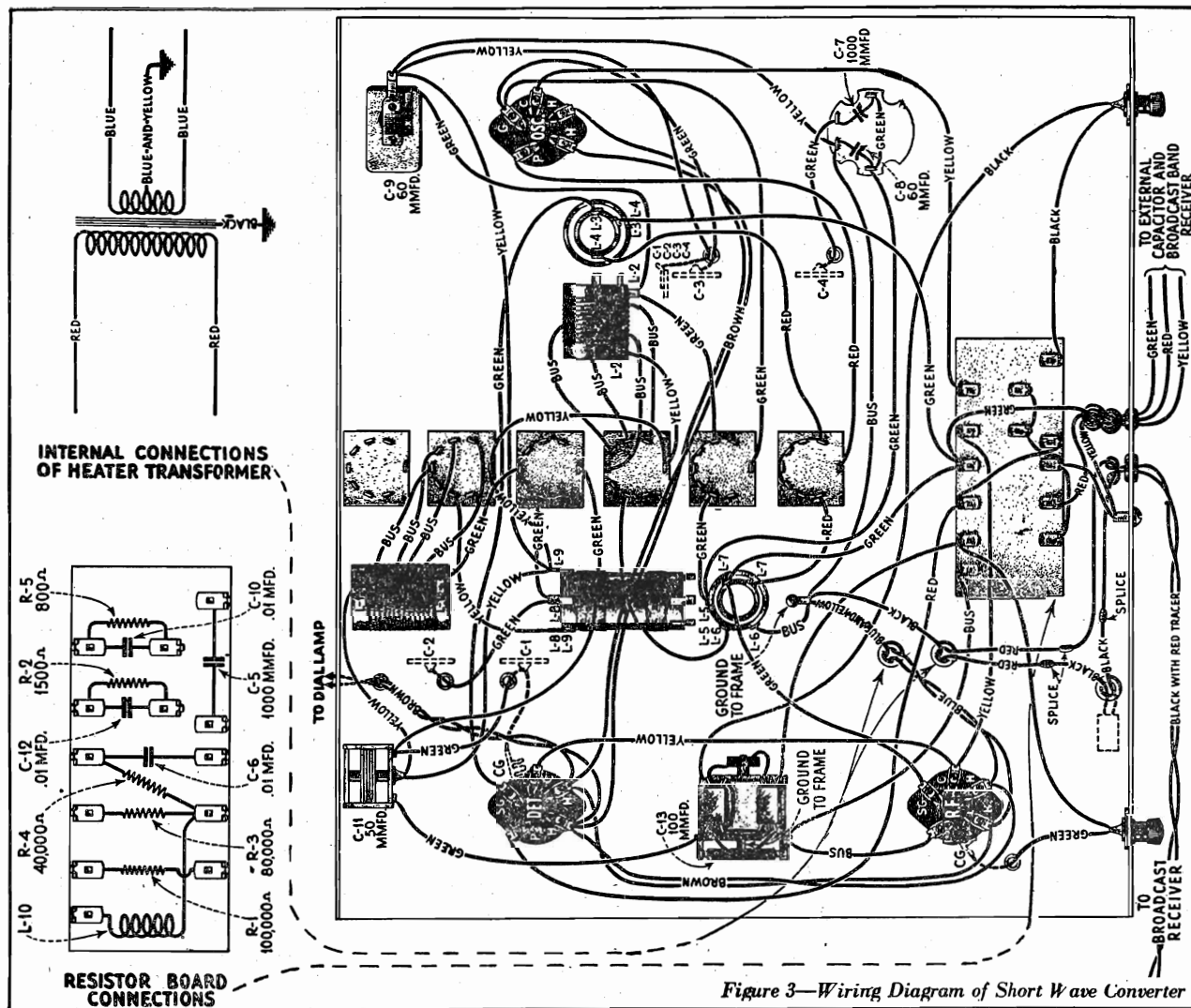

Figure 3—Wiring Diagram of Short Wave Converter

SERVICE DATA

Service information in conjunction with the broadcast receiver is covered in the Service Notes already issued on RCA-Victor Models R-8, R-10 or R-12. The Short Wave Converter is however somewhat different from the usual broadcast receiver and a discussion of its service problems will help the service man in the performance of his work.

ELECTRICAL DESCRIPTION OF CONVERTER CIRCUIT

The RCA Victor Short Wave Converter uses three Radiotrons, one UY-224 as an R. F. Amplifier, one UY-224 as a Detector and one UY-227 as an Oscillator. The purpose of the Converter is to amplify the incoming high frequency signal by means of the R. F. stage, beat it with a local Oscillator signal and produce a modulated beat frequency by means of the Detector, extract the beat frequency so that it may be amplified by means of the broadcast receiver. A special tuning Capacitor, for tuning the Oscillator and Detector stages simultaneously, is incorporated in this unit. A series of tapped coils in conjunction with a range switch provides for the shifting to various bands without interchanging coils as with the older style Converters. Also this switch changes the capacity used by the tuning capacitor so that the frequency range of each band is approximately the same. A small trimmer capacitor, known as the Resonator, is used to re-align the detector circuit with the Oscillator whenever the band is changed or the I. F. frequency is shifted. The shaft that controls the Resonator capacitor is also mechanically connected to the operating switch and the antenna switch. It is so made that when the power is turned "off," the antenna is shifted to the broadcast receiver so that broadcast reception may be obtained.

MODEL RO-23 Alignment Data

R. C. A. VICTOR CO., INC.

Alignment at each end of the 51.3-98.5 meter band are also for the 98.5-200 meter band. The other alignment is for the five high frequency ranges. When these alignments are properly made, and an intermediate frequency between 1050 and 1100 K. C. is used, the Resonator control will function properly and the various short wave broadcasting services will fall within the bands indicated on the dial.

Special Notes on Effects of Aligning and I. F. Frequency Changes

Unless the line-up adjustments are carefully and properly made, the dial markings will be found to be incorrect. If it is necessary to replace the oscillator coil, the leads on the new coil should be made as short as possible and the alignment of the set checked. Also during operation it is preferable that the I. F. frequency of 1075 be used although any frequency between 1050 and 1100 will be satisfactory.

In unusual cases where local conditions preclude the use of a frequency between 1050 and 1100 K. C., considerably more variation in I. F. frequency without the loss of sensitivity will be permissible. However, the calibration will be shifted considerably, especially at the lower frequencies.

(2) DIAL INDICATOR

The indicator on the dial lamp should be so adjusted that the dial will read 100 when the tuning capacitor is at its maximum capacity position. It is important that this be checked before any alignment adjustments are made.

(3) BROADCASTING STATION HARMONICS

When tuning on the 98.5-200 meter band, the second and third harmonics of broadcasting stations will be heard and as there is no regular short wave broadcasting service on this band such signals may be discounted as better results will be obtained by listening to such programs on their regular wave band.

On the lower length bands, the short wave broadcasting stations will be received in the bands indicated for each position of the range switch with but few exceptions. Broadcasting received at other positions of the dial should therefore be viewed with skepticism unless it is definitely proved to be a short wave station and not a higher harmonic of a broadcast station.

(4) LOCAL STATION INTERFERENCE

When the receiver is located very close to a powerful transmitter, either broadcasting or code it is recommended that an antenna not exceeding 30 feet in length be used. However, if a longer antenna is necessary in order to obtain satisfactory reception, cross modulation from the local station may occur. Such a condition is evidenced by the local station coming in on unmodulated carriers on top of some short wave stations.

Under such conditions, it is advisable to use a tuned input circuit to the short Wave Converter. Such an input circuit can readily be made by winding 3 turns of No. 20 wire on a 1/4 inch tube, spacing the turns 1/8 inch apart. The coil is tuned by means of a .0005 mfd. variable capacitor and should be connected from the antenna input to ground. Such a combination will tune broadly from 13.8 to 51 meters.

(5) ACOUSTIC FEEDBACK

If Acoustic feedback is experienced, it is an indication that the two chassis are not entirely supported on rubber. While with the usual broadcast receiver, such a condition is not so vitally necessary, with high frequency reception, unless each chassis is entirely floating in its rubber mounting and its shafts and knobs not touching the cabinet, howling will result.

(6) BROADCAST RECEIVER HARMONICS

When tuning through the various bands, at various points a slight breathing tone can be heard that is not a C. W. signal, but a harmonic of the broadcast receiver oscillator, being received. If an intermediate frequency of between 1050 and 1100 is used, these will not fall on any of the short wave broadcasting services. However, if they should and thereby cause a whistle, a slight shift — 5 kilocycles of the intermediate frequency — will eliminate the interference. Returning the Short Wave Converter will be necessary to restore the signal to its normal intensity. Identification of these harmonics can be made by this means, a slight shift in the intermediate frequency causing them to disappear while an incoming signal will slowly diminish in volume.

(1) ALIGNMENT OF CONVERTER CIRCUITS

If the Converter does not cover the bands indicated on the range switch, refer to Figure 2 and make the following adjustments. A calibrated oscillator or frequency meter is desirable although if the service man is familiar with the stations in the high frequency spectrum, the location of these stations on the scale can be used as a guide for making the adjustments. Also a calibrated short-wave receiver that has an oscillating detector may be used to check the Converter oscillator frequency.

Adjust the broadcast receiver so that it is accurately set at 1075 K. C. — the short wave I. F. frequency. Set the "Range" switch at the 51.3-98.5 meter position.

Set the tuning capacitor at its minimum position. (Plates fully out of mesh.)

Place the external oscillator in operation at 5960 K. C.

Adjust the oscillator shunt capacitor C-8 so that the external oscillator will be heard in the loudspeaker or noted on an output meter.

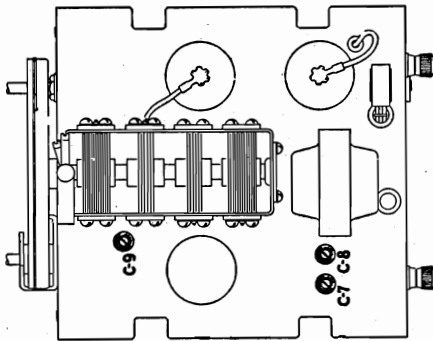

Figure 2—Location of Adjusting Capacitors

If the calibrated oscillator is not available then a calibrated receiver may be used to receive and check the frequency of the converter oscillator. The capacitor C-8 should be adjusted until the oscillator frequency is 7035 K. C.

If a wave meter is the only standard available, then a second receiver should be calibrated from it by means of one of the several methods for doing this accurately.

If no standards are available a satisfactory adjustment can be made by increasing capacitor C-8 slightly more than the point at which the 49 meter broadcasting stations are heard when the tuning capacitor is at its minimum position on the 51.3-98.5 meter band. (With C-8 set at minimum the 49 meter band should be received.)

Now shift the tuning capacitor to its maximum position. The Converter oscillator frequency, as picked up on a calibrated receiver, should be adjusted for 4130 K. C. by the oscillator series capacitor C-7. So adjusted, the receiver will receive a 3055 K. C. signal with an intermediate frequency of 1075.

Again, if no standards are available, an adjustment of C-7 that will give a definite point of resonance near the center range of the Resonator control with the tuning dial at 50 will be satisfactory.

After checking each end of the 51.3 to 98.5 meter band, shift the range switch to the 39-51.3 meter position. Set the tuning capacitor at its minimum position (plates fully out of mesh) and the I. F. frequency at 1075. Adjust the oscillator shunt capacitor C-9 until the oscillator frequency is 9100 K. C. or the receiver will respond to a signal of 3025 K. C. If no standards are available, adjust C-9 until the 49 meter stations all fall within and near the center of the 49 meter markings on the dial. Unless this adjustment is properly made the short wave broadcasting will not fall within the bands marked on the dial.

R. C. A. - VICTOR CO., INC.

MODEL RAE-26
Assembly Wiring

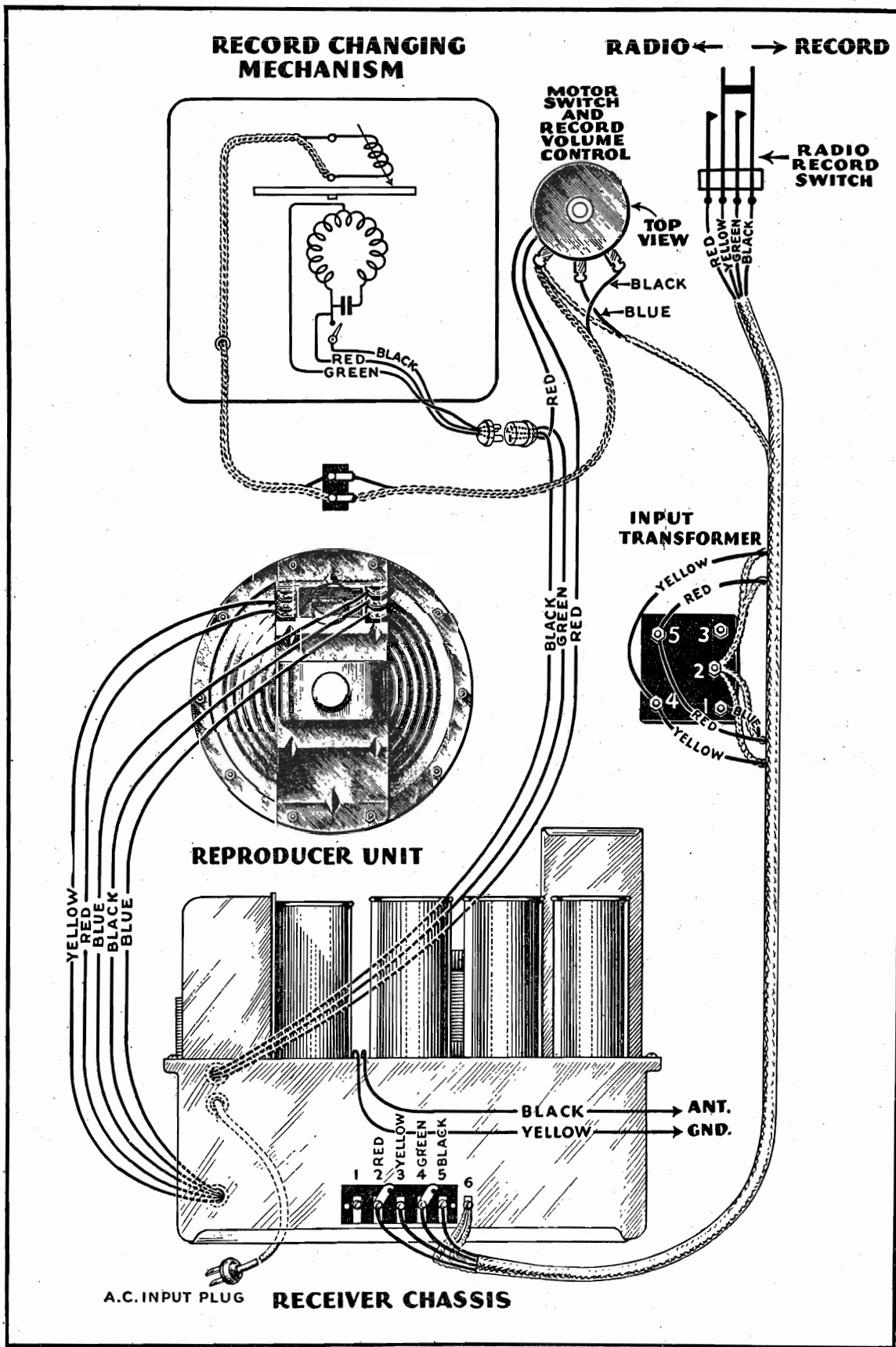

Assembly Wiring Diagram of RAE-26

MODEL RAE-26
Schematic

R. C. A. VICTOR CO., INC.

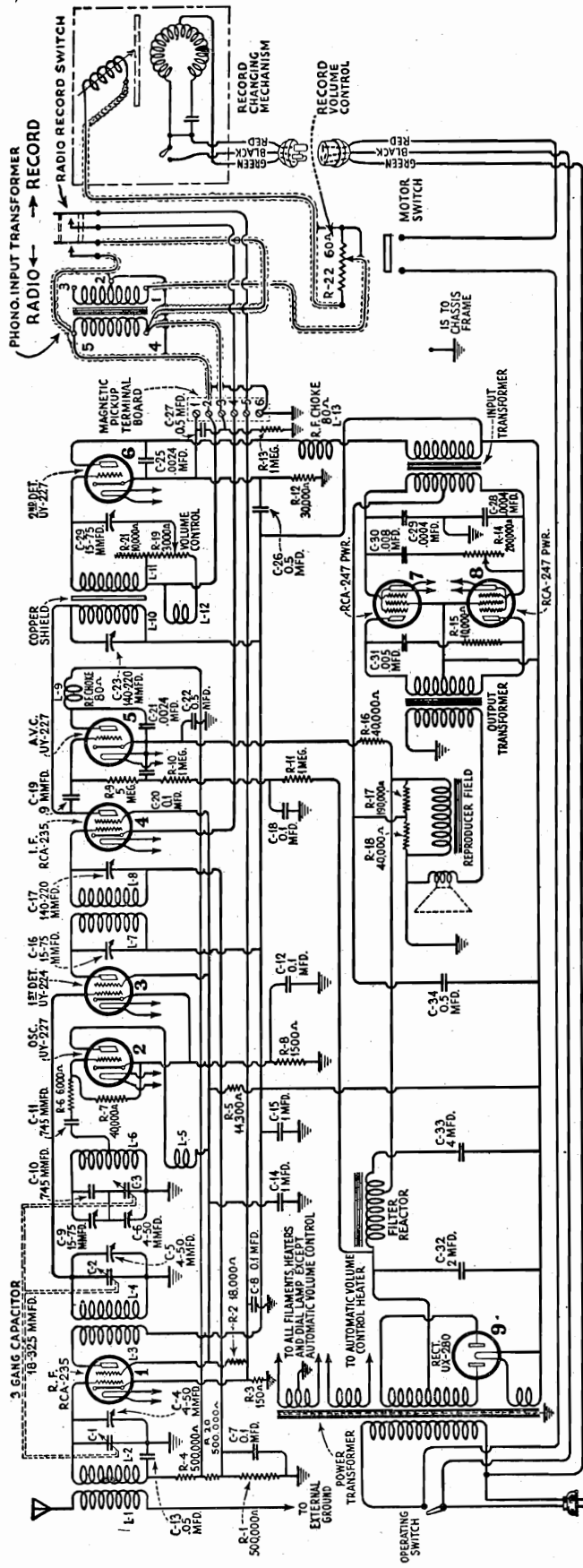

PEAK FREQUENCY-175 KC

RCA Victor Radiola Automatic Electrola RAE-26 is a nine tube radio receiver combined with the perfected RCA Victor Automatic Record Changing Mechanism.

The Automatic Record Changing Mechanism provides for the continuous playing of ten 10-inch records. Provision is also made for a turntable speed of 33 1/3 R.P.M. as well as 78 R.P.M. This makes the mechanism adaptable for the playing of the Program Transcription Records as well as standard records, either manually or automatically.

SERVICE DATA

The Receiver assembly and Loudspeaker used in Model RAE-26 is exactly the same as that used in the R-11. A reference to the Service Notes for the R-11 will therefore give the details of any Service information required on these units.

A reference to the Service Notes on the RCA Victor Automatic Record Changing Mechanism gives details of any service work that may be required on this unit. It will also be found useful in identifying the replacement parts listed below. Figure 1 shows the schematic circuit diagram and Figure 2 the assembly wiring diagram.

Model RAE-26 (1931)

OSC	27	1 DET	24A
IF	35	RF	35
A.V.C.	27	2 DET	27
AF	47	RECT	80

PILOT NO. 41 MAZDA
FRONT

MODEL RAE-26
Resistance Data

R. C. A. VICTOR CO., INC.

All tubes removed from socket and AC plug disconnected from power supply line. Field coil disconnected. All pickup equipment disconnected from terminal board and terminals 2 and 3 should be joined. Also terminals 4 and 5 should be interconnected.

From Chassis To	Correct	Incorrect
Aerial to Ground Post	40 ohms	
Chassis to		
RF Control Grid(early model)	1,000,005 ohms	BLC- in tuned circuit (.1 mfd)
RF Control Grid(late model)	1,500,005 ohms	BLC- in tuned circuit (.05 mfd)
RF Cathode	150 ohms	BC-1 IF Tr. Sec -Y
RF Screen Grid	18,150 ohms	BC- rf K-Y (.1 mfd)
RF Plate	32,508 ohms	BC- rf Sg-Y (.1 mfd)
RF Plate to '80 Fil	58 ohms	BC-47 Sg- Y (.5 mfd)
1 Detector Control Grid	5 ohms	BC- '80 F- Spkr div. tap
1 Detector Cathode	1,500 ohms	BC- rf P-Y (1. mfd)
1 Detector Screen	18,150 ohms	See RF Screen Grid
1 Detector Plate	32,541.5 ohms	TC-Y
1 Detector Plate to '80 Fil	93.5 ohms	BC-AVC ohk-Y
Oscillator Control Grid	41,500 ohms	BLC- in tuned circuit (.05 mfd)
Oscillator Cathode	1,500 ohms	BC-1 IF Tr. Sec -Y
Osc Plate and Det Screen	18,151 ohms	BC- rf K-Y (.1 mfd)
IF Control Grid (all models)	500,041.5 ohms	BC- rf Sg-Y (.1 mfd)
IF Control Grid- AVC Plate (early)	121.5 ohms	BC-47 Sg- Y (.5 mfd)
IF Screen Grid	18,150 ohms	BC- '80 F- Spkr div. tap
IF Plate	32,491.5 ohms	BC- rf P-Y (1. mfd)
IF Plate -'80 Fil	41.5 ohms	See RF Screen Grid
AVC Control Grid (early)	7,230,285 ohms	TC-Y
AVC Control Grid (late)	4,230,285 ohms	BC-Y (.1 mfd)
AVC Cathode	270,000 ohms	BC-Y (.5 mfd)
AVC Plate	1,000,085 ohms	TC-1 IF Tr Sec

2 Det Control Grid(Pickup Board Tex#2) 93.5 ohms
 2 Det Control Grid to V.C. Arm 3,093.5-10,093.5 ohms TC-2D Cg- VC Arm
 2 Det Cathode 30,000 ohms BC- Tex#1-Tex#3
 BC- 2 DK-'80 Fil

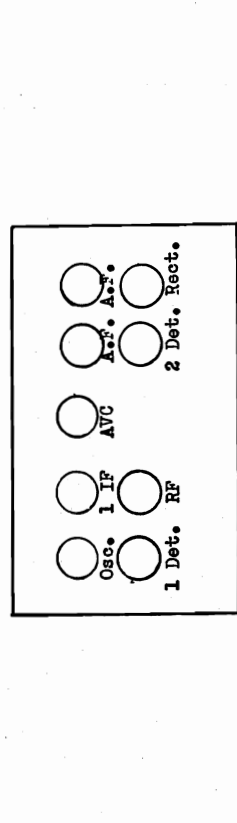

Line Voltage 110. Volume Control does not change voltages.

Tube	Cathode- Heater	Control Grid- Cathode	Screen Grid- Cathode	Plate- Plate Filament	Cathode Current Voltage
RF	2.	0.1*	75.	205.	5.0 ma 2.2
Osc.	8.	0.	-	60.	5.0 2.2
1 Det.	7.	7.0	70.	200.	0.5 2.2
IF	2.	0.1*	75.	205.	5.0 2.2
AVC	0.	0.	-	25.	- 2.2
2 Det.-20.	8.C*	8.C*	-	180.	0.5 2.2
Pwer -	10.	10.	210.	205.	25. 2.2
Pwer -	10.	10.	210.	205.	25. 2.2

* Not true reading because of resistance in the circuit.

MODEL M-30
Auto Radio
Schematic

R. C. A. VICTOR CO INC.

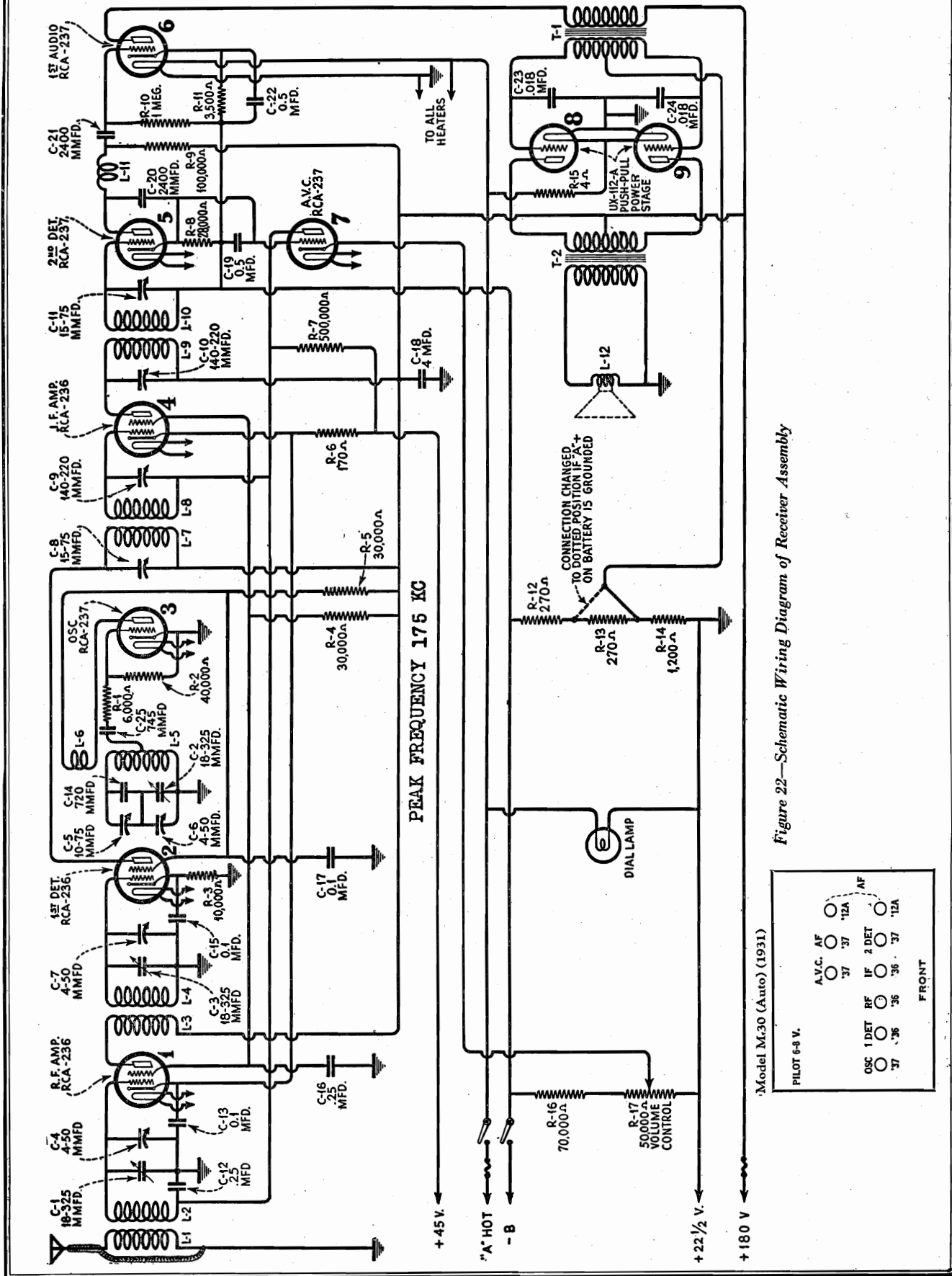
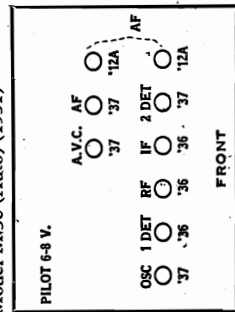

Figure 22—Schematic Wiring Diagram of Receiver Assembly

Model M-30 (Auto) (1931)



R. C. A. VICTOR CO., INC.

MODEL M-30
Auto Radio
Chassis

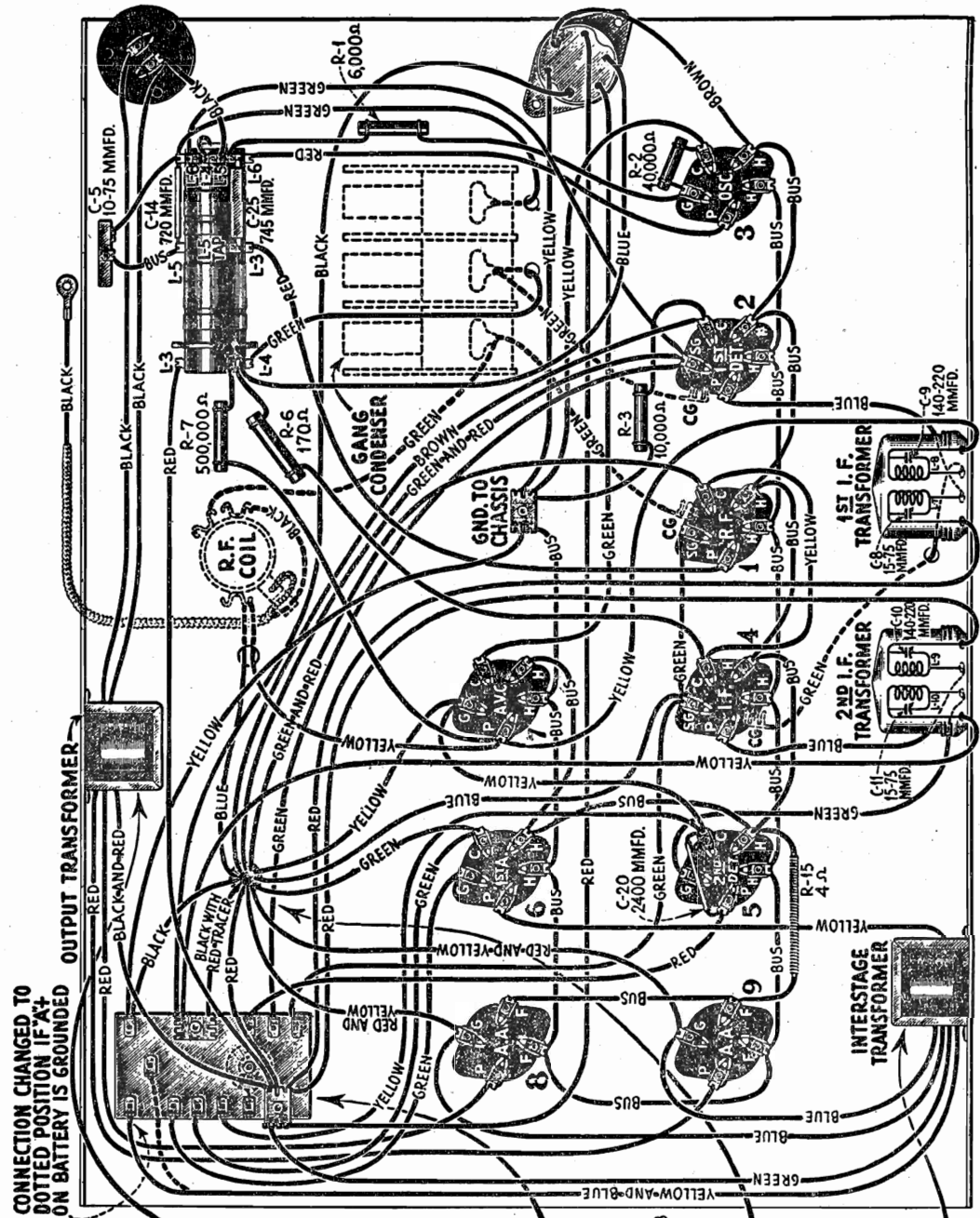

CONNECTION CHANGED TO
DOTTED POSITION IF "A"
ON BATTERY IS GROUNDED

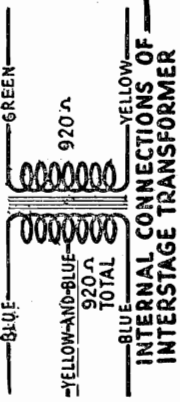
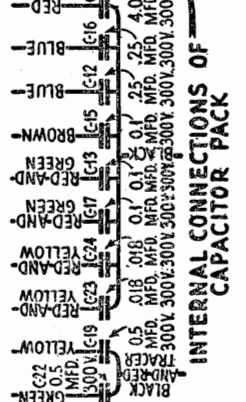
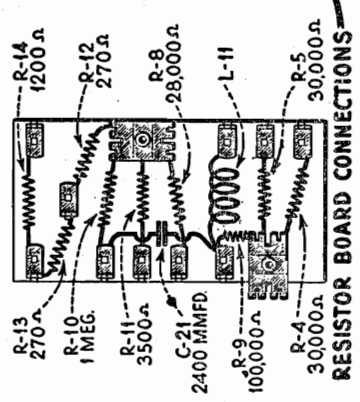
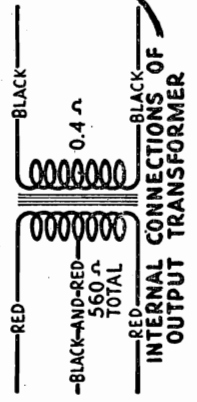

Figure 26—Wiring Diagram of Receiver Unit

**MODEL M-30
Auto Radio
Notes Part 1.**

R. C. A. VICTOR CO., INC.

CONTROL BOX

The control box, Figure 2, contains the station selector knob, the dial scale, the volume control and the key switch. It is provided with a felt strip and mounting clamp for attaching to the steering column of the car. The dial scale is marked in channels (multiply by 10 for kilocycles) and is of the non-glare type. The switch is provided with a key, which when removed, locks the radio at the "off" position.

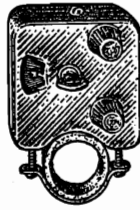

Figure 2—Control Box



Figure 3—Loudspeaker

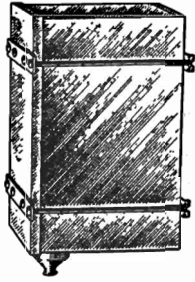

Figure 4—Battery Box

LOUDSPEAKER

The loudspeaker, Figure 3, used in the automobile equipment is of the permanent magnet, dynamic type. It is housed in a smooth black finished metal container which also acts as an effective baffle. Due to the presence of the strong magnetic field, even when the set is turned off, special provision has been made to prevent metallic substances from being drawn into the air gap of the speaker and thereby cause rattles. The speaker edge and center is entirely closed, thus preventing such entry from the front. A fine gauze covering is placed over the back, thus eliminating any such matter from entering from that side. The cord outlet is provided with a rubber bushing that closes up its opening. The speaker has excellent frequency characteristics and is of extremely rugged construction.

BATTERY BOX

A special heavy steel battery box, Figure 4, is furnished as optional equipment when it is either undesirable or impossible to install the batteries behind or under the seats or in the rear compartment of the car. This box is so constructed that the batteries may be mounted and connected therein and then lifted into position beneath the car. Four carriage bolts, each provided with two lock nuts, hold it in place.



Figure 5—Antenna Plate

ANTENNA PLATE

The antenna plate, Figure 5, is provided for use when a roof antenna is not already installed in the car. It is provided with special bolts and clamps that allow easy mounting to the frame of the car. Due to the high sensitivity of this receiver, satisfactory results may be obtained with the undercar antenna except in districts where the signal intensity of all stations is extremely low. In such cases a roof antenna must be erected in accordance with the instructions given in Part I, Section 3.

SERVICE AND INSTALLATION NOTES

for

**RCA Victor Automobile Radiola
Model M-30**

INTRODUCTION

The RCA Victor Automobile Radiola, Model M-30, is a nine tube Super-Heterodyne radio receiver designed for automobile or motor boat use. Features of this receiver are; sensitivity and selectivity equal to that of high quality home receivers, high output Class B amplifier giving a large undistorted output with a small plate battery drain, permanent magnet dynamic loudspeaker requiring no external field supply, automatic volume control using entirely new principles of operation and extremely low battery consumption for both heater and plate supply. This feature allows the use of the automobile battery as "A" supply without imposing an additional load upon it that cannot be readily compensated for by a slight generator charging readjustment. The low plate current drain allows excellent "B" battery life. Use of the new automobile type Radiotrons eliminates the possibility of Radiotron failure due to vibration or varying heater voltage such as is encountered in automobile driving.

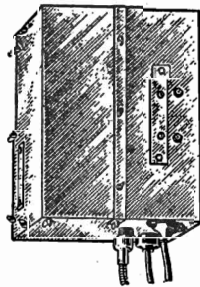

Figure 1—Receiver Assembly

In the design of this receiver, special attention has been given to the ease with which the installation may be made, and the elimination of interference originating in the ignition system. Thorough shielding of all parts together with proper design of the receiver makes it possible to reduce ignition interference to a negligible degree. This is done without any sacrifice in the sensitivity of the receiver.

A description of the various units follows.

RECEIVER ASSEMBLY

The receiver assembly, Figure 1, is housed in a metal case that acts as an effective mechanical and electrical shield. A bracket is provided for mounting so that dismounting is a comparatively simple operation, requiring the removal of but one screw.

The top section of this container is fastened by means of wing nuts. This provides for easy removal for checking or replacing Radiotrons. The battery and control box cable, the loudspeaker cable and the flexible tuning cable are all held in place by means of fittings which allow their easy removal in case the box is to be removed from its mounting. The case is finished in a dull smooth black that is not easily scratched and harmonizes with the usual car finishes.

**MODEL M-30
Auto Radio
Notes Part 3**

R. C. A. VICTOR CO., INC.

ANTENNA PLATE

Location The antenna plate, if used, should be mounted under the car and as far to the rear as possible. Also it must be as low (close to the road) as possible and still maintain the clearance of the lowest point of the car from the road.

Usually, it is mounted on the opposite side from the Muffler and exhaust pipe to prevent crowding. See Figure 13. In some cases, it is desirable to mount the plate crosswise to the car chassis. Avoid any location that will place the plate in a position that will impede the free motion of the chassis parts such as springs, drive shaft, or axles, as damage to the antenna will result.

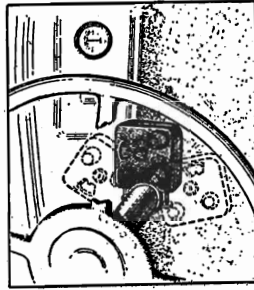

Figure 12—Position for Control Box in Order to Make Adjustments

Mounting After determining the proper location, fasten the plates together with the screws provided. Adjust the length so that the plate is as long as possible and still fulfill the foregoing conditions. Assemble the mounting bolts onto the plate as shown in Figure 5 and fasten the clamps to the car frame. Then tighten the bolt that holds the antenna plate to the bracket and the screw and lock nut that holds the bracket to the car frame. *Too much attention to the proper tightening of these screws is impossible, as any loosening of this plate that results in one end dropping while the car is driven at high speed may result in an accident.*

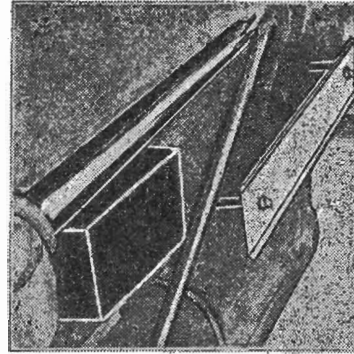

Figure 13—Typical Location of Antenna Plate and Battery Box

“B” BATTERIES

Location If possible, the “B” batteries should be mounted under one of the seats or behind the back of the rear seat. In cars having a rear compartment or trunk, the batteries may be located therein.

However, if such a place is not possible, then a battery box must be used. This box can usually be mounted under the car by fastening to the floor boards. Its location should be as far from the muffler and exhaust pipe as possible, as the heat from these parts will have a detrimental effect on the life of the batteries.

LOUDSPEAKER

Location The Loudspeaker may be mounted at several locations, in most automobiles. However, the preferable location is on the bulkhead facing the rear of the car and on the opposite side from that of the receiver. If several locations are available, choose the one that gives the best acoustical results. This can easily be determined by experiment by not mounting the speaker until the rest of the equipment is in place and the receiver operating.

Mounting The instructions for mounting the receiver assembly apply equally well to the loud speaker, with the exception that the loudspeaker is mounted direct, there being no bracket provided. A template is also provided for this unit. No clearance space above the loudspeaker is required.

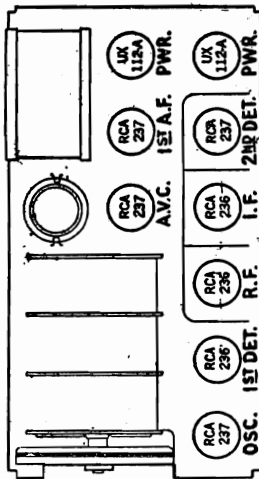

Figure 10—Radiotron Socket Location

CONTROL UNIT

Location The control unit is mounted on the steering column at a convenient height for the driver. Due to the large size of the steering wheel hub on some cars, this distance must be adjusted for best visibility.

Mounting Place the felt around the steering column and hold it in place by means of string or a piece of tape. Remove one screw from the clamp and place the box and clamp around the felt. Replace the screw that was removed and tighten both screws equally.

FLEXIBLE SHAFT

Location The flexible shaft is used to mechanically connect the tuning capacitor in the receiver assembly to the drive and dial in the control box. It should be placed and fastened to the car so that it connects these two points together and is clear of any foot room or instruments. On some cars a special length shaft will be required. Such flexible shafts are listed in Part IV, page 24.

Mounting Turn the Station Selector until the flat side of the shaft may be seen through the hole in the side of the unit. Insert the end of the shaft into the opening at the rear of the Control Unit making certain that it engages the end of the shaft inside of the latter. Turn the shaft until the set screw is visible and tighten the set screw against the flat side of the shaft. Thread the coupling nut of the shaft onto the Control unit.

Turn the Station Selector knob clockwise so that the dial is at the extreme counter-clockwise position. Then insert the free end of the shaft into the opening provided on the receiver, turning the Station Selector knob back and forth until the shaft meshes. Tighten the collar that holds the shaft to the receiver unit.

After completing these two operations, slowly turn the Station Selector knob to the extreme clockwise and then to the extreme counter-clockwise position. Normally, this will insure the use of the complete range of the dial. If, however, it is noticed that a slight amount of tension is present at either end of the dial, then the control unit must be turned on the steering column in the direction of the tension, while making this adjustment. Then returning it to its normal position will relieve this additional tension. Figure 12 gives the details of this latter adjustment.

R. C. A. VICTOR CO., INC.

MODEL M-30
Auto Radio
Notes Part 4

Mounting Using the cover of the battery box as a template, locate the cover on the floor boards under the car and mark the boards for the center of the four mounting bolts. Drill four 3/8" holes in the floor boards. Insert the four carriage bolts in the holes from the top. Make sure the hanger bolts are in place in the cover and fasten the cover to the four bolts in the floor board. In the case of cars having metal floor boards, machine screws with spacers must be used instead of carriage bolts. Make sure that the mounting bolts do not project too far down into the box so that they will fail to clear the batteries.

After fastening the top securely in place, place the "B" batteries in the box and connect them to the receptacle as shown in Figure 14. Slip the cambric cover over the fuse and place the paper strips and plate over the terminals. Then lift the box into place, swing the hanger bolts into place and tighten both nuts securely. Care should be taken to draw up on all four nuts gradually.

For mounting both the antenna plate and the battery box, it is desirable to place the car on a "lift."

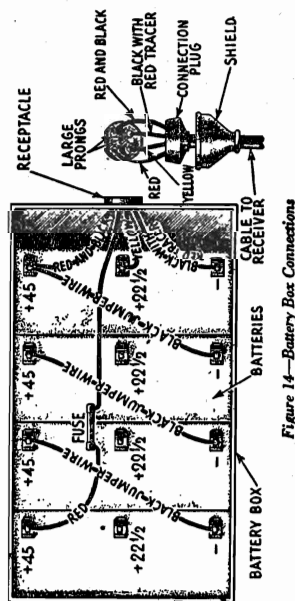

Figure 14—Battery Box Connections

IGNITION EQUIPMENT

Two .75 mfd. capacitors, six spark plug type suppressors and one distributor type suppressor are furnished to be installed in the car's ignition system so that its R.F. radiation may be reduced to a point so as not to interfere with radio reception.

One .75 mfd. capacitor is connected across the output of the generator. Remove a screw from the generator frame, usually the one holding the cut-out, insert the screw through the hole in the capacitor clamp and replace the screw. Connect the lead from the end of the capacitor to the terminal on the generator side of the cut-out switch.

The other capacitor is connected from the battery side of the ammeter to the car frame. Usually, one of the screws on the underside of the dash can be used to hold the capacitor, thereby making the ground connection. Then connect the lead to the ammeter terminal.

The spark plug type suppressors are inserted in series with each high tension lead at its point of connection to the plug. The distributor suppressor is inserted in series with the high tension lead from the coil at its point of connection to the distributor.

There are a number of variations in the installation of this ignition suppression equipment that are covered in Part II.

(2) CONNECTIONS

Loudspeaker to Receiver Insert the plug on the end of the loudspeaker cable into the two-contact receptacle on the end of the receiver. Fasten the pigtail under the self-tapping screw as shown in Figure 9

Main Cable to Receiver A long cable, from the control unit and battery box, is attached to the receiver by means of a six point female plug. Insert the plug into the receptacle on the receiver. A metal cap is fitted over two studs at the same time. Fasten the nuts over these studs securely.

Main Cables to Batteries Drill 1/2" hole in the toe boards directly below the end of the receiver unit to which connections are made. (If any holes that may be used for this purpose are already available, drilling additional holes is unnecessary). Pass the free end of the cable through the hole and thence to the "B" Battery location. Possibly other holes must also be drilled. Connect the "B" batteries to the cable as shown in Figure 15. The metal braid must be pushed back from the free end and taped so that sufficient length leads are obtained for connecting the batteries. If the battery box is used, solder the four prong plug onto the end of the cable as shown in Figure 14.

The cable should be fastened to the chassis of the car by means of the clamps or staples provided. Take up any slack by making a loop and tape securely.

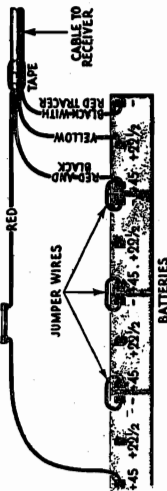

Figure 15—Cable Connections to "B" Batteries

Receiver to Antenna The antenna lead should follow the shortest practical path between the receiver and the antenna. It is very desirable to avoid passing it through the engine compartment or close to the ignition coil, if mounted on the dash or compartment side of bulkhead.

If a roof antenna is used, cut the lead from the antenna as short as possible and still allow length for connection. Then cut the antenna lead and shield from the receiver to a proper length, allowing about two inches extra on the shield so that it may be slit and braided into a pigtail. Solder and tape the connections securely. Then solder the frayed part of the pigtail and either fasten or solder it securely to the car frame. The pigtail should be as short as possible and a good electrical joint made to the car frame

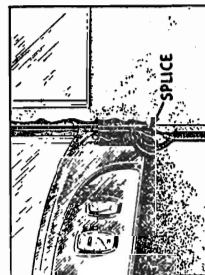

Figure 16—Proper Method of Grounding Shield When Using Roof Antenna

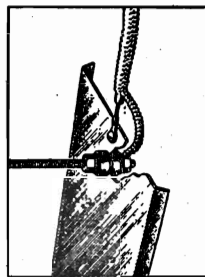

Figure 17—Proper Method of Grounding Shield When Using Plate Antenna

If the antenna plate is used, the antenna lead and shield should be cut in the same manner as for the top antenna, except that the pigtail must be slightly longer. An eyelet terminal is provided for soldering to the end of the antenna lead so that it may be held by the screw and nut at the end of the antenna plate. The pigtail should be fastened under one of the nuts that hold the plate to its mounting bolts. Figures 16 and 17 illustrate the correct manner in making both types of connections.

Receiver to "A" Battery One side of the "A" Battery connection is made through the frame of the car. The "hot" side is made by means of a single lead that is brought out from the main cable. This lead is provided with a lug that should be fastened under the nut that holds the battery connection to the starting motor switch

This completes the installation. All cables should be fastened securely to the car so that interference with its operation is avoided. This is especially true of those under the dash which may

**MODEL M-30
Auto Radio
Notes Part 5**

R. C. A. VICTOR CO., INC.

support. Usually, this can follow the path of the dome light lines. It should be noted however, that if the ignition coil is mounted on either side of the dash, it is preferable to run the lead-in down the column further from the coil.

4. Again test the antenna from the set end of the lead-in to ground for any possible shorts. If none exist then replace the head lining. Figure 18 shows a typical roof antenna installation.

(4) INSTALLATIONS ON MODEL A FORDS

The Model A Ford presents a somewhat involved problem for the installation of the RCA Victor Automobile Radiola. The reason for this is that due to the gasoline tank being part of the cowl, the usual location for the set and speaker cannot be used. Two positions for the receiver and three for the speaker are possible, each having several disadvantages.

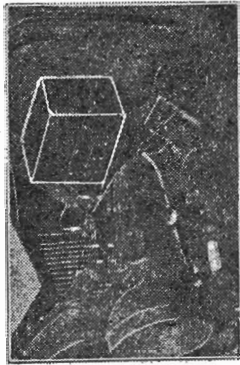

Figure 19—Location of Units in Model A Ford

The receiver unit may be mounted in the engine compartment as shown in Figure 19, more easily than at any other location. The disadvantage of this position is that due to the high noise level present even when suppressors are used, a satisfactory installation cannot always be made. The receiver is also subject to motor fumes, water and steam used in engine cleaning and the usual atmospheric conditions.

The other alternative position for the receiver is on the right side of the driving compartment as shown in Figure 20. The dimensions for a template to be mounted to the body to hold the receiver or loudspeaker are shown in Figure 21. The interference may be successfully eliminated at this location but the position of the receiver interferes with the leg room of the person riding beside the driver.

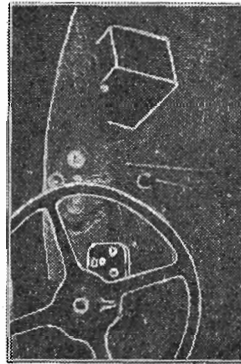

Figure 20—Alternative Position for Receiver and Loudspeaker

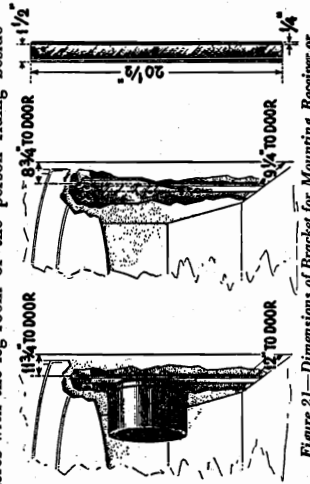

Figure 21—Dimensions of Bracket for Mounting Receiver or Loudspeaker to Side of Driver's Compartment

The loudspeaker may be mounted at either side of the car, using the same template for a bracket as that shown in Figure 21, on models not having pockets at either of these locations. On such models, such as the roadster, the loudspeaker can be mounted directly behind the gear shift lever and bolted to the seat base. This location is not seriously in the way and gives good acoustical results.

The batteries may be mounted behind the rear seat in the sedan models, in the rear compartment of coupes and roadsters or in a battery box on any model.

interfere with the driver's foot room. The switch may then be turned "on" and the receiver operated in the usual manner. Normally, starting the car engine will not introduce any objectionable noise. However, if ignition interference is present that is objectionable, then a reference to Part II, will give the details for clearing up this trouble.

(3) INSTALLATION OF ROOF ANTENNA

In cars not already equipped with roof antennae, the usual installation is that of the antenna plate. Due to the high sensitivity of this receiver, entirely satisfactory results are obtained from the plate antenna in most installations. However, if the car is to be operated in a locality remote from any stations and having a general low degree of signal strength, the erection of a roof antenna is advisable. The following details cover the procedure to be used in a majority of closed cars. This work should be done by a competent "trim" man as a degree of skill, only acquired by experience, is necessary in removing and replacing the fabric top of a car.

The antenna should be composed of copper screen having a total area of at least 10 square feet. It should be located as far to the rear as possible and insulated from any metal part of the car which may ground it. In some cars having a metal rib in the center, it will be advisable to make the antenna in two pieces and use insulated wire as straps for bonding it together. All joints together with the lead-in connections should be well soldered.

USE TINNED OR BRIGHT COPPER OR BRONZ WIRE SCREEN ONLY. DO NOT USE GALVANIZED OR OXIDIZED COPPER SCREEN

USE SCREEN OF PROPER WIDTH AND CUTTING LENGTHWISE

CUT HOLE TO CLEAR DOME LIGHT AND SOLDER EDGES OF SCREEN

DROP THE HEAD LINING FROM FRONT OF CAR SO THAT IT CAN BE FOLDED ON REAR SEAT WHILE WORKING

USE TINNED OR BRIGHT COPPER OR BRONZ WIRE SCREEN ONLY. DO NOT USE GALVANIZED OR OXIDIZED COPPER SCREEN

USE SCREEN OF PROPER WIDTH AND CUTTING LENGTHWISE

CUT HOLE TO CLEAR DOME LIGHT AND SOLDER EDGES OF SCREEN

DROP THE HEAD LINING FROM FRONT OF CAR SO THAT IT CAN BE FOLDED ON REAR SEAT WHILE WORKING

USE TINNED OR BRIGHT COPPER OR BRONZ WIRE SCREEN ONLY. DO NOT USE GALVANIZED OR OXIDIZED COPPER SCREEN

USE SCREEN OF PROPER WIDTH AND CUTTING LENGTHWISE

CUT HOLE TO CLEAR DOME LIGHT AND SOLDER EDGES OF SCREEN

DROP THE HEAD LINING FROM FRONT OF CAR SO THAT IT CAN BE FOLDED ON REAR SEAT WHILE WORKING

USE TINNED OR BRIGHT COPPER OR BRONZ WIRE SCREEN ONLY. DO NOT USE GALVANIZED OR OXIDIZED COPPER SCREEN

USE SCREEN OF PROPER WIDTH AND CUTTING LENGTHWISE

CUT HOLE TO CLEAR DOME LIGHT AND SOLDER EDGES OF SCREEN

DROP THE HEAD LINING FROM FRONT OF CAR SO THAT IT CAN BE FOLDED ON REAR SEAT WHILE WORKING

USE TINNED OR BRIGHT COPPER OR BRONZ WIRE SCREEN ONLY. DO NOT USE GALVANIZED OR OXIDIZED COPPER SCREEN

USE SCREEN OF PROPER WIDTH AND CUTTING LENGTHWISE

CUT HOLE TO CLEAR DOME LIGHT AND SOLDER EDGES OF SCREEN

DROP THE HEAD LINING FROM FRONT OF CAR SO THAT IT CAN BE FOLDED ON REAR SEAT WHILE WORKING

USE TINNED OR BRIGHT COPPER OR BRONZ WIRE SCREEN ONLY. DO NOT USE GALVANIZED OR OXIDIZED COPPER SCREEN

USE SCREEN OF PROPER WIDTH AND CUTTING LENGTHWISE

CUT HOLE TO CLEAR DOME LIGHT AND SOLDER EDGES OF SCREEN

DROP THE HEAD LINING FROM FRONT OF CAR SO THAT IT CAN BE FOLDED ON REAR SEAT WHILE WORKING

USE TINNED OR BRIGHT COPPER OR BRONZ WIRE SCREEN ONLY. DO NOT USE GALVANIZED OR OXIDIZED COPPER SCREEN

USE SCREEN OF PROPER WIDTH AND CUTTING LENGTHWISE

CUT HOLE TO CLEAR DOME LIGHT AND SOLDER EDGES OF SCREEN

DROP THE HEAD LINING FROM FRONT OF CAR SO THAT IT CAN BE FOLDED ON REAR SEAT WHILE WORKING

USE TINNED OR BRIGHT COPPER OR BRONZ WIRE SCREEN ONLY. DO NOT USE GALVANIZED OR OXIDIZED COPPER SCREEN

USE SCREEN OF PROPER WIDTH AND CUTTING LENGTHWISE

CUT HOLE TO CLEAR DOME LIGHT AND SOLDER EDGES OF SCREEN

DROP THE HEAD LINING FROM FRONT OF CAR SO THAT IT CAN BE FOLDED ON REAR SEAT WHILE WORKING

USE TINNED OR BRIGHT COPPER OR BRONZ WIRE SCREEN ONLY. DO NOT USE GALVANIZED OR OXIDIZED COPPER SCREEN

USE SCREEN OF PROPER WIDTH AND CUTTING LENGTHWISE

CUT HOLE TO CLEAR DOME LIGHT AND SOLDER EDGES OF SCREEN

DROP THE HEAD LINING FROM FRONT OF CAR SO THAT IT CAN BE FOLDED ON REAR SEAT WHILE WORKING

USE TINNED OR BRIGHT COPPER OR BRONZ WIRE SCREEN ONLY. DO NOT USE GALVANIZED OR OXIDIZED COPPER SCREEN

USE SCREEN OF PROPER WIDTH AND CUTTING LENGTHWISE

CUT HOLE TO CLEAR DOME LIGHT AND SOLDER EDGES OF SCREEN

DROP THE HEAD LINING FROM FRONT OF CAR SO THAT IT CAN BE FOLDED ON REAR SEAT WHILE WORKING

USE TINNED OR BRIGHT COPPER OR BRONZ WIRE SCREEN ONLY. DO NOT USE GALVANIZED OR OXIDIZED COPPER SCREEN

USE SCREEN OF PROPER WIDTH AND CUTTING LENGTHWISE

CUT HOLE TO CLEAR DOME LIGHT AND SOLDER EDGES OF SCREEN

DROP THE HEAD LINING FROM FRONT OF CAR SO THAT IT CAN BE FOLDED ON REAR SEAT WHILE WORKING

USE TINNED OR BRIGHT COPPER OR BRONZ WIRE SCREEN ONLY. DO NOT USE GALVANIZED OR OXIDIZED COPPER SCREEN

USE SCREEN OF PROPER WIDTH AND CUTTING LENGTHWISE

CUT HOLE TO CLEAR DOME LIGHT AND SOLDER EDGES OF SCREEN

DROP THE HEAD LINING FROM FRONT OF CAR SO THAT IT CAN BE FOLDED ON REAR SEAT WHILE WORKING

USE TINNED OR BRIGHT COPPER OR BRONZ WIRE SCREEN ONLY. DO NOT USE GALVANIZED OR OXIDIZED COPPER SCREEN

USE SCREEN OF PROPER WIDTH AND CUTTING LENGTHWISE

CUT HOLE TO CLEAR DOME LIGHT AND SOLDER EDGES OF SCREEN

DROP THE HEAD LINING FROM FRONT OF CAR SO THAT IT CAN BE FOLDED ON REAR SEAT WHILE WORKING

USE TINNED OR BRIGHT COPPER OR BRONZ WIRE SCREEN ONLY. DO NOT USE GALVANIZED OR OXIDIZED COPPER SCREEN

USE SCREEN OF PROPER WIDTH AND CUTTING LENGTHWISE

CUT HOLE TO CLEAR DOME LIGHT AND SOLDER EDGES OF SCREEN

DROP THE HEAD LINING FROM FRONT OF CAR SO THAT IT CAN BE FOLDED ON REAR SEAT WHILE WORKING

USE TINNED OR BRIGHT COPPER OR BRONZ WIRE SCREEN ONLY. DO NOT USE GALVANIZED OR OXIDIZED COPPER SCREEN

USE SCREEN OF PROPER WIDTH AND CUTTING LENGTHWISE

CUT HOLE TO CLEAR DOME LIGHT AND SOLDER EDGES OF SCREEN

DROP THE HEAD LINING FROM FRONT OF CAR SO THAT IT CAN BE FOLDED ON REAR SEAT WHILE WORKING

USE TINNED OR BRIGHT COPPER OR BRONZ WIRE SCREEN ONLY. DO NOT USE GALVANIZED OR OXIDIZED COPPER SCREEN

USE SCREEN OF PROPER WIDTH AND CUTTING LENGTHWISE

CUT HOLE TO CLEAR DOME LIGHT AND SOLDER EDGES OF SCREEN

DROP THE HEAD LINING FROM FRONT OF CAR SO THAT IT CAN BE FOLDED ON REAR SEAT WHILE WORKING

USE TINNED OR BRIGHT COPPER OR BRONZ WIRE SCREEN ONLY. DO NOT USE GALVANIZED OR OXIDIZED COPPER SCREEN

USE SCREEN OF PROPER WIDTH AND CUTTING LENGTHWISE

CUT HOLE TO CLEAR DOME LIGHT AND SOLDER EDGES OF SCREEN

DROP THE HEAD LINING FROM FRONT OF CAR SO THAT IT CAN BE FOLDED ON REAR SEAT WHILE WORKING

USE TINNED OR BRIGHT COPPER OR BRONZ WIRE SCREEN ONLY. DO NOT USE GALVANIZED OR OXIDIZED COPPER SCREEN

USE SCREEN OF PROPER WIDTH AND CUTTING LENGTHWISE

CUT HOLE TO CLEAR DOME LIGHT AND SOLDER EDGES OF SCREEN

DROP THE HEAD LINING FROM FRONT OF CAR SO THAT IT CAN BE FOLDED ON REAR SEAT WHILE WORKING

USE TINNED OR BRIGHT COPPER OR BRONZ WIRE SCREEN ONLY. DO NOT USE GALVANIZED OR OXIDIZED COPPER SCREEN

USE SCREEN OF PROPER WIDTH AND CUTTING LENGTHWISE

CUT HOLE TO CLEAR DOME LIGHT AND SOLDER EDGES OF SCREEN

DROP THE HEAD LINING FROM FRONT OF CAR SO THAT IT CAN BE FOLDED ON REAR SEAT WHILE WORKING

USE TINNED OR BRIGHT COPPER OR BRONZ WIRE SCREEN ONLY. DO NOT USE GALVANIZED OR OXIDIZED COPPER SCREEN

USE SCREEN OF PROPER WIDTH AND CUTTING LENGTHWISE

CUT HOLE TO CLEAR DOME LIGHT AND SOLDER EDGES OF SCREEN

DROP THE HEAD LINING FROM FRONT OF CAR SO THAT IT CAN BE FOLDED ON REAR SEAT WHILE WORKING

USE TINNED OR BRIGHT COPPER OR BRONZ WIRE SCREEN ONLY. DO NOT USE GALVANIZED OR OXIDIZED COPPER SCREEN

USE SCREEN OF PROPER WIDTH AND CUTTING LENGTHWISE

CUT HOLE TO CLEAR DOME LIGHT AND SOLDER EDGES OF SCREEN

DROP THE HEAD LINING FROM FRONT OF CAR SO THAT IT CAN BE FOLDED ON REAR SEAT WHILE WORKING

USE TINNED OR BRIGHT COPPER OR BRONZ WIRE SCREEN ONLY. DO NOT USE GALVANIZED OR OXIDIZED COPPER SCREEN

USE SCREEN OF PROPER WIDTH AND CUTTING LENGTHWISE

CUT HOLE TO CLEAR DOME LIGHT AND SOLDER EDGES OF SCREEN

DROP THE HEAD LINING FROM FRONT OF CAR SO THAT IT CAN BE FOLDED ON REAR SEAT WHILE WORKING

USE TINNED OR BRIGHT COPPER OR BRONZ WIRE SCREEN ONLY. DO NOT USE GALVANIZED OR OXIDIZED COPPER SCREEN

USE SCREEN OF PROPER WIDTH AND CUTTING LENGTHWISE

CUT HOLE TO CLEAR DOME LIGHT AND SOLDER EDGES OF SCREEN

DROP THE HEAD LINING FROM FRONT OF CAR SO THAT IT CAN BE FOLDED ON REAR SEAT WHILE WORKING

USE TINNED OR BRIGHT COPPER OR BRONZ WIRE SCREEN ONLY. DO NOT USE GALVANIZED OR OXIDIZED COPPER SCREEN

USE SCREEN OF PROPER WIDTH AND CUTTING LENGTHWISE

CUT HOLE TO CLEAR DOME LIGHT AND SOLDER EDGES OF SCREEN

DROP THE HEAD LINING FROM FRONT OF CAR SO THAT IT CAN BE FOLDED ON REAR SEAT WHILE WORKING

USE TINNED OR BRIGHT COPPER OR BRONZ WIRE SCREEN ONLY. DO NOT USE GALVANIZED OR OXIDIZED COPPER SCREEN

USE SCREEN OF PROPER WIDTH AND CUTTING LENGTHWISE

CUT HOLE TO CLEAR DOME LIGHT AND SOLDER EDGES OF SCREEN

DROP THE HEAD LINING FROM FRONT OF CAR SO THAT IT CAN BE FOLDED ON REAR SEAT WHILE WORKING

USE TINNED OR BRIGHT COPPER OR BRONZ WIRE SCREEN ONLY. DO NOT USE GALVANIZED OR OXIDIZED COPPER SCREEN

USE SCREEN OF PROPER WIDTH AND CUTTING LENGTHWISE

CUT HOLE TO CLEAR DOME LIGHT AND SOLDER EDGES OF SCREEN

DROP THE HEAD LINING FROM FRONT OF CAR SO THAT IT CAN BE FOLDED ON REAR SEAT WHILE WORKING

USE TINNED OR BRIGHT COPPER OR BRONZ WIRE SCREEN ONLY. DO NOT USE GALVANIZED OR OXIDIZED COPPER SCREEN

USE SCREEN OF PROPER WIDTH AND CUTTING LENGTHWISE

CUT HOLE TO CLEAR DOME LIGHT AND SOLDER EDGES OF SCREEN

DROP THE HEAD LINING FROM FRONT OF CAR SO THAT IT CAN BE FOLDED ON REAR SEAT WHILE WORKING

USE TINNED OR BRIGHT COPPER OR BRONZ WIRE SCREEN ONLY. DO NOT USE GALVANIZED OR OXIDIZED COPPER SCREEN

USE SCREEN OF PROPER WIDTH AND CUTTING LENGTHWISE

CUT HOLE TO CLEAR DOME LIGHT AND SOLDER EDGES OF SCREEN

DROP THE HEAD LINING FROM FRONT OF CAR SO THAT IT CAN BE FOLDED ON REAR SEAT WHILE WORKING

USE TINNED OR BRIGHT COPPER OR BRONZ WIRE SCREEN ONLY. DO NOT USE GALVANIZED OR OXIDIZED COPPER SCREEN

USE SCREEN OF PROPER WIDTH AND CUTTING LENGTHWISE

CUT HOLE TO CLEAR DOME LIGHT AND SOLDER EDGES OF SCREEN

DROP THE HEAD LINING FROM FRONT OF CAR SO THAT IT CAN BE FOLDED ON REAR SEAT WHILE WORKING

USE TINNED OR BRIGHT COPPER OR BRONZ WIRE SCREEN ONLY. DO NOT USE GALVANIZED OR OXIDIZED COPPER SCREEN

USE SCREEN OF PROPER WIDTH AND CUTTING LENGTHWISE

CUT HOLE TO CLEAR DOME LIGHT AND SOLDER EDGES OF SCREEN

DROP THE HEAD LINING FROM FRONT OF CAR SO THAT IT CAN BE FOLDED ON REAR SEAT WHILE WORKING

USE TINNED OR BRIGHT COPPER OR BRONZ WIRE SCREEN ONLY. DO NOT USE GALVANIZED OR OXIDIZED COPPER SCREEN

USE SCREEN OF PROPER WIDTH AND CUTTING LENGTHWISE

CUT HOLE TO CLEAR DOME LIGHT AND SOLDER EDGES OF SCREEN

DROP THE HEAD LINING FROM FRONT OF CAR SO THAT IT CAN BE FOLDED ON REAR SEAT WHILE WORKING

USE TINNED OR BRIGHT COPPER OR BRONZ WIRE SCREEN ONLY. DO NOT USE GALVANIZED OR OXIDIZED COPPER SCREEN

USE SCREEN OF PROPER WIDTH AND CUTTING LENGTHWISE

CUT HOLE TO CLEAR DOME LIGHT AND SOLDER EDGES OF SCREEN

DROP THE HEAD LINING FROM FRONT OF CAR SO THAT IT CAN BE FOLDED ON REAR SEAT WHILE WORKING

USE TINNED OR BRIGHT COPPER OR BRONZ WIRE SCREEN ONLY. DO NOT USE GALVANIZED OR OXIDIZED COPPER SCREEN

USE SCREEN OF PROPER WIDTH AND CUTTING LENGTHWISE

CUT HOLE TO CLEAR DOME LIGHT AND SOLDER EDGES OF SCREEN

DROP THE HEAD LINING FROM FRONT OF CAR SO THAT IT CAN BE FOLDED ON REAR SEAT WHILE WORKING

USE TINNED OR BRIGHT COPPER OR BRONZ WIRE SCREEN ONLY. DO NOT USE GALVANIZED OR OXIDIZED COPPER SCREEN

USE SCREEN OF PROPER WIDTH AND CUTTING LENGTHWISE

CUT HOLE TO CLEAR DOME LIGHT AND SOLDER EDGES OF SCREEN

DROP THE HEAD LINING FROM FRONT OF CAR SO THAT IT CAN BE FOLDED ON REAR SEAT WHILE WORKING

USE TINNED OR BRIGHT COPPER OR BRONZ WIRE SCREEN ONLY. DO NOT USE GALVANIZED OR OXIDIZED COPPER SCREEN

USE SCREEN OF PROPER WIDTH AND CUTTING LENGTHWISE

CUT HOLE TO CLEAR DOME LIGHT AND SOLDER EDGES OF SCREEN

DROP THE HEAD LINING FROM FRONT OF CAR SO THAT IT CAN BE FOLDED ON REAR SEAT WHILE WORKING

USE TINNED OR BRIGHT COPPER OR BRONZ WIRE SCREEN ONLY. DO NOT USE GALVANIZED OR OXIDIZED COPPER SCREEN

USE SCREEN OF PROPER WIDTH AND CUTTING LENGTHWISE

CUT HOLE TO CLEAR DOME LIGHT AND SOLDER EDGES OF SCREEN

DROP THE HEAD LINING FROM FRONT OF CAR SO THAT IT CAN BE FOLDED ON REAR SEAT WHILE WORKING

USE TINNED OR BRIGHT COPPER OR BRONZ WIRE SCREEN ONLY. DO NOT USE GALVANIZED OR OXIDIZED COPPER SCREEN

USE SCREEN OF PROPER WIDTH AND CUTTING LENGTHWISE

CUT HOLE TO CLEAR DOME LIGHT AND SOLDER EDGES OF SCREEN

DROP THE HEAD LINING FROM FRONT OF CAR SO THAT IT CAN BE FOLDED ON REAR SEAT WHILE WORKING

USE TINNED OR BRIGHT COPPER OR BRONZ WIRE SCREEN ONLY. DO NOT USE GALVANIZED OR OXIDIZED COPPER SCREEN

USE SCREEN OF PROPER WIDTH AND CUTTING LENGTHWISE

CUT HOLE TO CLEAR DOME LIGHT AND SOLDER EDGES OF SCREEN

DROP THE HEAD LINING FROM FRONT OF CAR SO THAT IT CAN BE FOLDED ON REAR SEAT WHILE WORKING

USE TINNED OR BRIGHT COPPER OR BRONZ WIRE SCREEN ONLY. DO NOT USE GALVANIZED OR OXIDIZED COPPER SCREEN

USE SCREEN OF PROPER WIDTH AND CUTTING LENGTHWISE

CUT HOLE TO CLEAR DOME LIGHT AND SOLDER EDGES OF SCREEN

DROP THE HEAD LINING FROM FRONT OF CAR SO THAT IT CAN BE FOLDED ON REAR SEAT WHILE WORKING

USE TINNED OR BRIGHT COPPER OR BRONZ WIRE SCREEN ONLY. DO NOT USE GALVANIZED OR OXIDIZED COPPER SCREEN

USE SCREEN OF PROPER WIDTH AND CUTTING LENGTHWISE

CUT HOLE TO CLEAR DOME LIGHT AND SOLDER EDGES OF SCREEN

DROP THE HEAD LINING FROM FRONT OF CAR SO THAT IT CAN BE FOLDED ON REAR SEAT WHILE WORKING

USE TINNED OR BRIGHT COPPER OR BRONZ WIRE SCREEN ONLY. DO NOT USE GALVANIZED OR OXIDIZED COPPER SCREEN

USE SCREEN OF PROPER WIDTH AND CUTTING LENGTHWISE

CUT HOLE TO CLEAR DOME LIGHT AND SOLDER EDGES OF SCREEN

DROP THE HEAD LINING FROM FRONT OF CAR SO THAT IT CAN BE FOLDED ON REAR SEAT WHILE WORKING

USE TINNED OR BRIGHT COPPER OR BRONZ WIRE SCREEN ONLY. DO NOT USE GALVANIZED OR OXIDIZED COPPER SCREEN

USE SCREEN OF PROPER WIDTH AND CUTTING LENGTHWISE

CUT HOLE TO CLEAR DOME LIGHT AND SOLDER EDGES OF SCREEN

DROP THE HEAD LINING FROM FRONT OF CAR SO THAT IT CAN BE FOLDED ON REAR SEAT WHILE WORKING

USE TINNED OR BRIGHT COPPER OR BRONZ WIRE SCREEN ONLY. DO NOT USE GALVANIZED OR OXIDIZED COPPER SCREEN

USE SCREEN OF PROPER WIDTH AND CUTTING LENGTHWISE

CUT HOLE TO CLEAR DOME LIGHT AND SOLDER EDGES OF SCREEN

DROP THE HEAD LINING FROM FRONT OF CAR SO THAT IT CAN BE FOLDED ON REAR SEAT WHILE WORKING

USE TINNED OR BRIGHT COPPER OR BRONZ WIRE SCREEN ONLY. DO NOT USE GALVANIZED OR OXIDIZED COPPER SCREEN

USE SCREEN OF PROPER WIDTH AND CUTTING LENGTHWISE

CUT HOLE TO CLEAR DOME LIGHT AND SOLDER EDGES OF SCREEN

DROP THE HEAD LINING FROM FRONT OF CAR SO THAT IT CAN BE FOLDED ON REAR SEAT WHILE WORKING

USE TINNED OR BRIGHT COPPER OR BRONZ WIRE SCREEN ONLY. DO NOT USE GALVANIZED OR OXIDIZED COPPER SCREEN

USE SCREEN OF PROPER WIDTH AND CUTTING LENGTHWISE

CUT HOLE TO CLEAR DOME LIGHT AND SOLDER EDGES OF SCREEN

DROP THE HEAD LINING FROM FRONT OF CAR SO THAT IT CAN BE FOLDED ON REAR SEAT WHILE WORKING

USE TINNED OR BRIGHT COPPER OR BRONZ WIRE SCREEN ONLY. DO NOT USE GALVANIZED OR OXIDIZED COPPER SCREEN

USE SCREEN OF PROPER WIDTH AND CUTTING LENGTHWISE

CUT HOLE TO CLEAR DOME LIGHT AND SOLDER EDGES OF SCREEN

DROP THE HEAD LINING FROM FRONT OF CAR SO THAT IT CAN BE FOLDED ON REAR SEAT WHILE WORKING

USE TINN

R. C. A. VICTOR CO., INC.

MODEL M-30
Auto Radio
Notes Part 6

PART II—SUPPRESSION OF IGNITION INTERFERENCE

In general, the use of the ignition suppressors and capacitors as described in Part I of this booklet will reduce the ignition interference to a negligible amount. However, on some installations it will be found that the noise is still present to a degree that is undesirable. In such cases, the following hints will aid the installation man in clearing up this trouble.

(1) IGNITION ADJUSTMENTS ON MOTOR

The first step in clearing up a noisy installation is to thoroughly check and remedy any defects in the ignition system of the car. By this we mean the spark plugs should be cleaned and adjusted or replaced, the breaker points replaced or adjusted and synchronized if necessary, the distributor arm filled out with solder until it makes a full even contact, and the generator commutator cleaned and its brushes adjusted or replaced. Also all wiring should be cleaned and loose connections or poor joints remedied. This work is the first step in the clean-up job and it should be done by a competent ignition expert, who has been acquainted with the need of accurately making all adjustments.

Usually, such adjustments though made on a motor that is performing efficiently, will materially reduce the ignition noise in the radio receiver.

(2) BY-PASS CAPACITORS

In some installations a re-arrangement of the connections of the by-pass capacitors will be found beneficial. For example, the by-pass capacitor connected to the battery side of the ammeter, if connected to the battery side of the ignition coil may be more effective.

In other cases using an additional capacitor at the coil, a total of three for the installation, will remedy the trouble. In all cases the generator capacitor is used, although if a clicking is heard when the cut-out makes and breaks its circuit, the pigtail should be connected to the load side rather than the generator side of the cut-out relay.

On some cars, two capacitors—one on each terminal—at the ammeter will greatly reduce the noise. This is especially true of 1932 Studebakers.

(3) IGNITION COIL

The car ignition coil, due to the high electromagnetic field surrounding it, should be at as great a distance as possible from the receiver, preferably on the opposite side of the metal bulkhead. On cars that have the ignition coil mounted on the instrument board directly over the receiver unit, it may be necessary to place it in the engine compartment. Where the switch is mounted into one end of the coil, the switch assembly must be removed from the coil and a bracket provided for mounting it. The leads from the coil should be shielded and the shield grounded. (Use Packard High Tension Cable for the high tension lead to the distributor).

Another important point is that of the primary connections. While not affecting the ignition system in its relation to the car, due to the use of auto-transformers as coils, interchanging the primary leads to a coil will sometimes materially reduce the ignition noise.

(4) ANTENNA PLATE

If grounding the antenna at its point of exit from the shield reduces or eliminates the noise, then it is feeding in through the antenna. The remedy in such a case is to place the antenna further toward the rear of the car. Also lowering it, slightly will greatly increase its signal pickup. Care must be exercised when doing this, to ascertain that the road clearance of the car is not reduced. Another important point to check is the grounding of the outer end of the antenna shield. Grounding this end of the shield to the chassis in practically all cases, materially reduces ignition noise. However, in certain cases, grounding this shield may increase the noise. In such cases the shield should be insulated with tape and left ungrounded.

(5) CABLES

Proper placing of the various shielded cables may have a bearing on the ignition noise picked up as well as contact noise caused by a variable contact between the cable shields and the car frame.

The antenna lead should follow the shortest path between the receiver unit and the antenna. If there is any possibility of the shield rubbing against any of the car frame, the cable should be taped or clamped in place. The "P" battery cable should be taut and any slack taken up by means of a loop. It should also be fastened or taped securely.

SPLICE-IN TYPE SUPPRESSOR

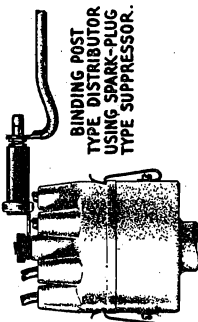
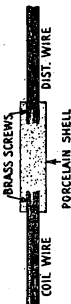

Figure 23—Installation of Various Types of Distributor Suppressors

(6) DISTRIBUTOR SUPPRESSORS

Three different styles of distributor suppressors are used, due to the variations in the distributor head connections. These are illustrated in Figure 23. The plug-in type is supplied with this equipment and is used in the majority of cars. The spark plug type with the end flattened is used in Packard and other cars having the binding post connection. The splice-in type is used on cars that do not have a readily removable connection to the distributor head. It is spliced into the high tension head, as close to the distributor as possible. This type may also be used on cars not having much room at the spark plugs, such as the Buick. While not furnished with regular equipment, the splice-in type suppressor is listed in Part IV.

PART III—SERVICE DATA

Service work in connection with the RCA Victor Automobile Radiola is very similar to that of the usual broadcast receiver. However, the following description of the circuit and method of making adjustments will be found helpful in locating and remedying any failure that may occur.

ELECTRICAL DESCRIPTION OF CIRCUIT

The following description of the circuit will give the service man a better understanding of the functioning of the receiver and thereby help him in his work. Figure 22 shows the schematic circuit diagram.

The first tube is the tuned R.F. stage. This is the screen Grid Radiotron, RCA-236. The control grid bias for this Radiotron is varied by means of the automatic volume control tube.

The output of the R. F. stage is coupled inductively to the grid coil of the first detector. At this point the oscillator output is also coupled inductively to the grid coil of the first detector.

MODEL M-30
Auto Radio
Notes Part 7

R. C. A. VICTOR CO., INC.

If the other adjustments have not been tampered with—the intermediate tuning capacitors—the following procedure may be used for adjusting these capacitors.

1. Loosen the receiver unit clamping screw and dismount the receiver from its mounting bracket. Do not remove any of the connections or the flexible cable.
2. Procure an R. F. oscillator giving a modulated signal at exactly 1400 K. C. and 600 K. C. Also procure a non-metallic screw driver—Stock No. 7065—and a No. 5 Spintite socket wrench.
3. An output indicator is necessary. This should be a current-squared thermo-galvanometer substituted or connected in parallel to the loudspeaker leads.

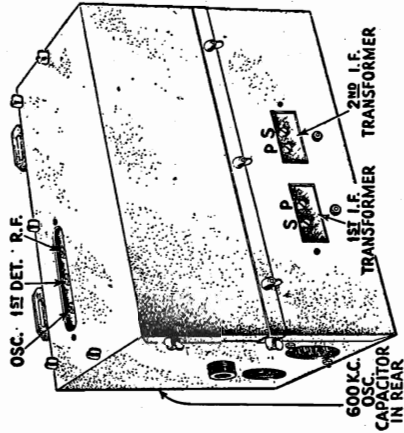

Figure 24—Location of Radio Frequency, Oscillator and Intermediate Frequency Adjustments

4. Remove the top cover of the receiver and remove the automatic volume control tube. Also ascertain that the tuning capacitor is fully meshed when the dial reads 150.
5. Place the oscillator in operation at exactly 1400 K. C. and couple it to the antenna. Set the dial at exactly 140 and adjust the coupling between the antenna and oscillator so that the output indicator does not give an excessive reading.
6. With the socket wrench, adjust the oscillator (see Figure 24), the first detector and the R. F. line-up capacitors until a maximum deflection is obtained in the output meter.
7. Set the oscillator at 600 K. C. Tune in this signal with the receiver and adjust for a deflection in the output meter. Now adjust the 600 K. C. series capacitor, Figure 24, until maximum output is obtained. Rock the tuning capacitor back and forth while making this adjustment.
8. Change the oscillator frequency to 1400 K. C. and set the dial at 140. Again make the adjustments given under 2, 3, 4, 5 and 6.

(2) I. F. TUNING CAPACITOR ADJUSTMENTS

A single intermediate frequency amplifier stage is used in this receiver. Two transformers are used and all circuits are tuned to 175 K. C. The circuits are peaked and when alignment adjustments are made, the capacitors are adjusted for maximum output. It will be necessary to remove the chassis from its mounting bracket as is the case of the R. F. adjustments.

This is a tuned grid circuit oscillator using a Radiotron RCA-237 and having a closely coupled plate coil that gives sufficient feedback to provide stable operation. The grid circuit is so designed that by means of a correct combination of capacity and inductance a constant frequency difference between the oscillator and the tuned R. F. circuits throughout the tuning range of the receiver is obtained.

The next circuit to examine is the first detector. The circuit is tuned by means of one of the gang condensers to the frequency of the incoming signal. Radiotron RCA-236 is used in this stage. In the grid circuit is present the incoming signal and oscillator frequencies. The beat frequency—175 K.C.—appears in the plate circuit of the first detector which is accurately tuned to 175 K.C.

The next stage is that of the I. F. amplifier. A single stage is used, requiring two I. F. transformers, consisting of four tuned circuits. The plate circuit of the first detector, the grid and plate circuit of the I. F. amplifier and the grid circuit of the second detector are all tuned to 175 K.C. Radiotron RCA-236 is used in this stage and its control grid voltage is also varied by means of the automatic volume control tube.

At this point it is well to consider the action of the automatic volume control tube as it controls the R. F. and I. F. amplifiers of the receiver. The grid of the automatic volume control tube, RCA-237, is connected direct to the cathode of the second detector.

The change in the bias voltage of the second detector, due to fluctuation of the signal, is applied to the grid of the A. V. C. tube. This produces a voltage drop across a resistor in the plate circuit which constitutes the control grid bias for the R. F. and I. F. amplifier. As the value of the plate current is a direct result of the voltage applied to the grid, a greater plate current gives a greater voltage drop across the resistor in its plate circuit and therefore a higher bias on the I. F. and R. F. stage. This results in less sensitivity and vice versa. The volume control varies the bias on the grid of the volume control tube.

The second detector is of the grid-biased type, using Radiotron RCA-237. The purpose of the second detector is to extract the audio frequency component of the R. F. signal which represents the voice or musical modulations produced in the studio of the broadcasting station. The audio component is extracted and used to drive the first A. F. tubes while the R. F. current is by-passed and not further used.

The output of the second detector is coupled by means of resistance coupling to the grid of the first A. F. Radiotron RCA-237. This audio stage is used as a driver for the Class B amplifier.

The output of the first audio stage is coupled by means of transformer coupling to the grids of the Radiotrons UX-112-A used as a push-pull Class "B" power stage. This stage is so biased that normally no plate current flows. However, as the grid swings positive due to the signal voltage being applied, plate current flows which is entirely of an audio character. As there is little residual current when no signal is present, this is a very economical amplifier as well as providing a high undistorted output—2 Watts.

The entire "A" battery current drain is 2.85 Amperes and the "B" current 12 M.A. minimum and 25 M.A. average maximum.

Filament and heater current is supplied from the storage battery in the car. Plate current is supplied by means of four medium size "B" batteries. A fuse is provided in both filament and plate circuits to protect the batteries and tubes.

(1) R. F. AND OSCILLATOR ADJUSTMENTS

Four adjustable capacitors are provided for aligning the R. F. circuits and adjusting the oscillator frequency so that it will be at a 175 K. C. difference from the incoming R. F. signal throughout the tuning range of the set. Poor quality, insensitivity, and possible inoperation of the receiver may be caused by these capacitors being out of adjustment.

R. C. A. VICTOR CO., INC.

MODEL M-30
Auto Radio
Voltage
Notes Part 8

(4) TESTING CAPACITORS

The by-pass capacitors are in a metal container. The internal wiring diagram is shown in Figure 26.

The capacitors can best be tested by freeing their connections and charging them with approximately 180 volts D. C. (use the four "B" batteries) and then noting their ability to hold the charge. After charging, short circuiting the capacitor terminals with a screw driver should produce a flash the size of the flash depending on the capacity of the capacitor and the voltage used for charging. A capacitor that will not hold its charge is defective and requires replacement of the entire unit.

(5) CHECKING RESISTANCE VALUES

The values of the various resistance units in this receiver are shown in the schematic diagram, Figure 22. When testing a receiver for defects, the various values of resistance should be checked. This may be done by a resistance bridge; the voltmeter-ammeter method, or by the following method.

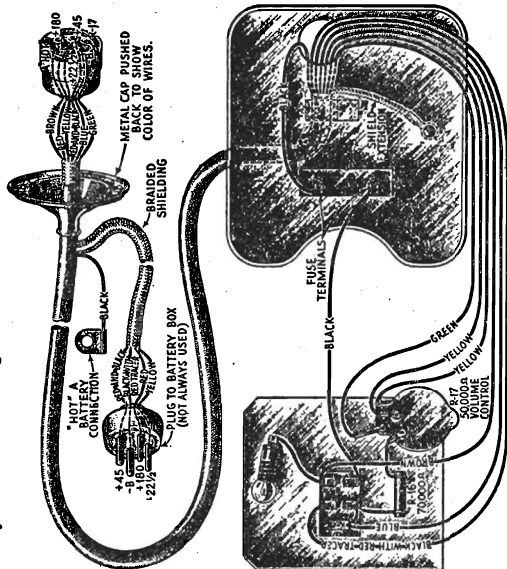

Figure 25—Control Box Wiring

For resistance of low value, 5000 ohms or less, use a voltmeter having a resistance not greater than 100 ohms per volt. For high values of resistance use a meter of 1000 ohms or more per volt. The Weston meters, Type 301 or 280, each have a resistance of 62 ohms per volt and are satisfactory for the low values. Use sufficient battery to give a good deflection on the meter, for example, a 45 volt "B" battery for a 0-50 voltmeter. Take two readings, one of the battery alone, and one of the battery with the unknown resistance in series. Then apply the following formula:

$$\left(\frac{\text{Reading obtained of battery alone}}{\text{Reading obtained with resistance in series}} - 1 \right) \times \text{Resistance of meter} = \text{Unknown Resistance}$$

(6) WIRING DIAGRAMS

The schematic wiring diagram is shown in Figure 22. The Control Unit wiring is shown in Figure 25 and the general wiring in Figure 26. A reference to these diagrams when locating trouble or replacing a unit will usually prove helpful. The internal connections of the cables are shown in Figure 27.

A detailed procedure for making these adjustments follows:

- a. Procure a modulated R. F. oscillator giving a signal at 175 K. C. The General Radio Type 360 is suitable. A non-metallic screw driver such as Stock No. 7065 is also necessary.
- b. Connect an output meter in the circuit. A current-squared galvanometer connected either in place of or across the loudspeaker leads is suitable.
- c. Remove the metal cover over the top of the receiver and then remove the oscillator and automatic volume control tube, Figure 10. Make a good ground connection between the receiver chassis and the car frame.
- d. Place the oscillator in operation and connect its output between the control grid connection of the first detector and ground, see Figure 10.
- e. Now adjust the secondary and primary of the second and first I. F. transformers until a maximum output is obtained in the output meter. Go through these adjustments a second time as a slight readjustment may be necessary. Be sure the output from the oscillator is not great enough to overload the first detector and I. F. tubes.
- f. When the adjustments are made, the set should perform at maximum efficiency. However, due to the interlocking of adjustments, it is a good plan to always follow the I. F. adjustments with the R. F. and oscillator lineup capacitor adjustments as described in Part III, Section I.

(3) VOLTAGE READINGS AT RADIOTRON SOCKETS

The following voltages taken at each Radiotron socket with the receiver in operating condition should prove of value when checking with test sets such as the Weston Model 547, Type 3, or others giving similar readings. The plate currents shown are not necessarily accurate for each tube, as the cable in the test set will cause some circuits to oscillate, due to its added capacity. Small variations of voltages will be caused by different tubes. Therefore, the following values must be taken as approximately those that will be found under varying conditions. The numbers in column 1 indicate the tube socket numbers shown in Figure 26.

RADIOTRON SOCKET VOLTAGES

Tube No.	VOLUME CONTROL AT MINIMUM						Heater or Filament Voltage
	Cathode to Filament or Control Grid Volts	Cathode or Screen Grid to Control Grid Volts	Cathode or Screen Grid to Plate Volts	Plate to Screen Grid M.A.	Screen Grid Current M.A.	Heater or Filament Volts	
1. R. F.	18	0.5	100	136	0	0	6.0
2. 1st Det.	1.0	3.0	42	150	0.25	0.1	6.0
3. Osc.	6.0	0	—	45	3.5	—	6.0
4. I. F.	18	1.0	100	136	0	0	6.0
5. 2nd Det.	12	10	—	110	0.5	—	6.0
6. 1st A. F.	15	2.0	—	165	3.5	—	6.0
7. A. V. C.	10	1.0	—	15	0	—	6.0
8. P. W. R.	—	20	—	155	1.5	—	4.5
9. P. W. R.	—	20	—	155	1.5	—	4.5

VOLUME CONTROL AT MAXIMUM (NO SIGNAL BEING RECEIVED)

1. R. F.	18	0.5	70	135	4.0	1.0	6.0
2. 1st Det.	1.0	3.0	42	150	0.25	0.1	6.0
3. Osc.	6.0	0	—	45	3.5	—	6.0
4. I. F.	18	0.5	70	135	4.0	1.0	6.0
5. 2nd Det.	12	10	—	110	0.5	—	6.0
6. 1st A. F.	15	2.0	—	165	3.5	—	6.0
7. A. V. C.	5.0	9.0	—	15	0	—	6.0
8. P. W. R.	—	20	—	155	1.5	—	4.5
9. P. W. R.	—	20	—	155	1.5	—	4.5

MODEL M-30
Auto Radio
Notes Part 9

R. C. A. VICTOR CO., INC.

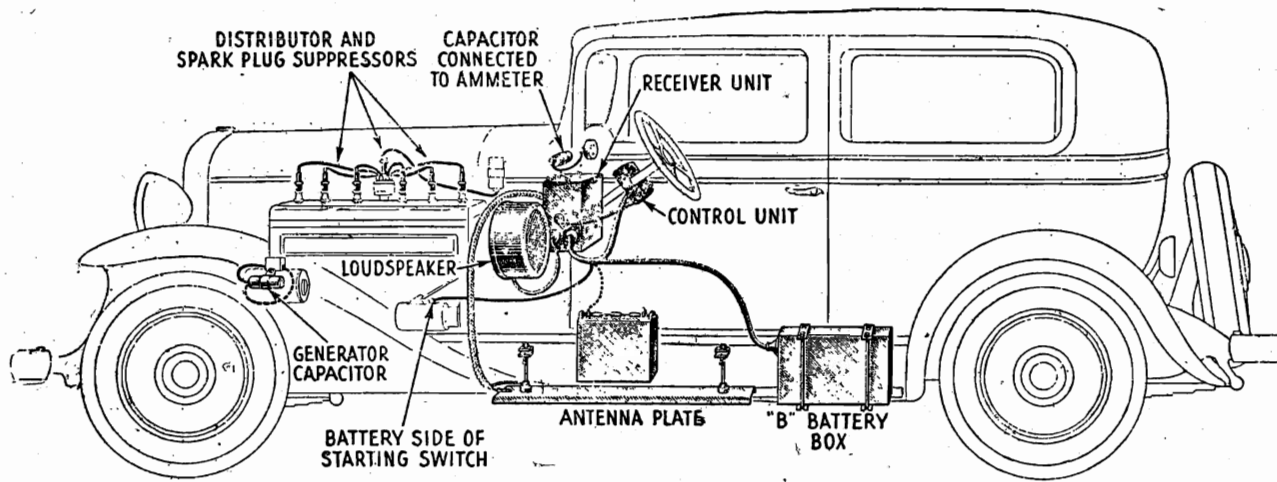

General View of Typical Installation of Automobile Radio

(7) VOLUME CONTROL

Normally, turning the volume control to the extreme counter-clockwise position will reduce the output volume of the receiver to zero. However, in event a powerful local station does not reduce to a satisfactory level, then check the following points.

- a. Automatic volume control tube. Try interchanging it with others of a similar type or replacing it with a new one.
- b. Volume control. Normally the volume control is of 50,000 ohms resistance. If for any reason it should be less, then the fixed resistor R-16 must also be reduced in value so that the proportion of 50,000 ohms to 70,000 ohms is maintained. For example—if the volume control measures 30,000 ohms, the fixed resistor should be replaced with one of 42,000 ohms. Such a replacement is much easier than a replacement of the complete volume control.

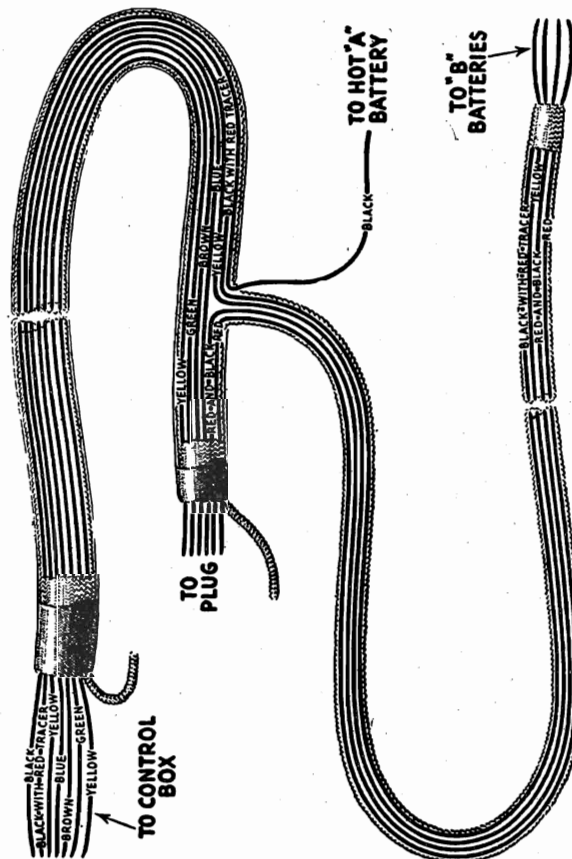

Figure 27—Internal Connections of Cables

PART IV—REPLACEMENT PARTS

On the following pages the parts that are required for replacement use are listed. It will be noted that several parts not included in the standard equipment are also listed. There are respectively, several types of ignition suppressors and special length flexible shafts. Reference to these parts has been made in the text and on some special installations they will be required.

R. C. A. VICTOR CO., INC.

MODEL M-30
Auto Radio
Parts List

REPLACEMENT PARTS—(Continued)

REPLACEMENT PARTS

Stock No.	DESCRIPTION	List Price	Stock No.	DESCRIPTION	List Price
2240	RECEIVER ASSEMBLY		3287	CONTROL BOX ASSEMBLY	
2546	Resistor—30,000 ohms—Carbon type—1 watt.	\$0.70	6153	Label—Metal trade mark label—Package of 5.	\$0.75
2736	Resistor—1 megohm—Carbon type—1 watt—Package of 5.	3.00	6154	Clamp—For clamping control box to steering wheel shaft—Package of 5.	.50
2741	Resistor—170 ohms—Carbon type—1 watt—Package of 5.	2.00	6155	Screw—Clamp mounting screw—Package of 50.	.50
2742	Idle—Tuning capacitor drive idler—Package of 5.	.80	6156	Shaft—Tuning dial shaft with gear and drive washer—Package of 5.	1.25
2747	Spring—Tuning capacitor drive tension spring—Package of 5.	.50	6157	Switch—Lock switch—Complete with mounting nut and washer.	.80
2749	Cap—Grid contractor cap—Package of 5.	1.50	6158	Volume control—Volume control complete with mounting nut.	1.50
2966	Resistor—28,000 ohms—Carbon type—1 watt—Package of 5.	2.50	6159	Nut—Knurled nut for lock switch—Package of 10.	.50
2994	Coil—2nd detector R.F. choke coil.	.60	6160	Resistor—70,000 ohms—Carbon type—1/2 watt—Package of 5.	2.00
3048	Resistor—500,000 ohms—Carbon type—1/2 watt—Package of 5.	2.50	6161	Dial scale—Package of 5.	.50
3078	Resistor—10,000 ohms—Carbon type—1 watt—Package of 5.	2.50	6162	Knob—Tuning control knob—Package of 5.	1.50
3118	Resistor—100,000 ohms—Carbon type—1 watt—Package of 5.	2.00	6163	Spring—Knob tension spring—Package of 25.	.50
3288	Socket—UY Radiotron socket—Complete with insulation strip.	.50	6164	Knob—Volume control knob—Package of 5.	1.50
6133	Socket—UX Radiotron socket—Complete with insulation strip.	.50	6165	Key—Lock switch key—Package of 10.	1.75
6134	Resistor—1200 ohms—Carbon type—1 watt—Package of 5.	2.00	6169	Lamp—Dial scale lamp—Package of 5.	.50
6135	Resistor—270 ohms—Carbon type—1/2 watt—Package of 5.	2.00	7430	Felt—Felt strip for steering column—Package of 10.	.50
6136	Resistor—3500 ohms—Carbon type—1 watt—Package of 5.	2.00	7431	Control box complete—Less flexible shaft and cable.	5.25
6137	Coil—R.F. coil.	1.90	7432	Cover assembly—Comprising top and bottom covers.	1.20
6138	Coil—1st detector and oscillator coil.	3.30	2975	Bracket assembly—Comprising brackets, studs, stop washer and lamp socket—Located inside of control box.	3.45
6139	Cord—Tuning condenser drive cord—Package of 5.	.65	6166	Rivet—Cone retaining ring mounting rivet—Package of 100.	.50
6140	Plug—6 prong male plug and plug receptacle.	.50	6167	Board—Terminal board with two terminals—Located on cone bracket—Package of 5.	1.00
6141	Receptacle—Two prong receptacle for speaker cord plug—Package of 2.	.70	6170	Plug—Two prong male plug—For cable No. 8832—Package of 5.	.75
6142	Resistor—6,000 ohms—Carbon type—1/2 watt—Package of 5.	2.00	6171	Rivet—For mounting speaker and front grille into housing—Package of 100.	.50
6143	Resistor—40,000 ohms—Carbon type—1 watt—Package of 5.	2.00	7433	Rivet—For mounting No. 8839 bracket to housing—Package of 100.	1.50
6144	Resistor—4 ohms—Flexible wire type—Package of 5.	1.00	7434	Screen—Speaker housing case wire screen—Package of 5.	1.75
6145	Cover Plate—Adjustable capacitor adjustment cover plate—Located on back receiver shield—Package of 5.	.50	8702	Screen—Dust screen for back of speaker housing case—Package of 5.	.80
6146	Screw—Self tapping hex head screw—For mounting cover plates to shield—Package of 40.	.60	8828	Ring—Cone retaining ring.	4.60
6147	Nut—Wing nut for receiver shield—Package of 20.	.60	8829	Magnet assembly—Comprising cone bracket, core and magnet.	
6148	Fuse—10 ampere—Package of 5.	.50			
6149	Bumper—Rubber bumpers—Located on receiver mounting bracket—Package of 10.	.50			
6150	Plug—Six prong female plug—Located on main cable.	.50			

Stock No.	DESCRIPTION	List Price	Stock No.	DESCRIPTION	List Price
6151	RECEIVER ASSEMBLY—Continued		8829	LOUDSPEAKER ASSEMBLY	
6152	Suppressor—Spark plug type suppressor.	\$0.65	8830	—Continued	
6175	Suppressor—Distributor type suppressor.	.65	8831	Cone—Speaker paper cone. Package of 5.	\$8.00
7062	Capacitor—Adjustable capacitor—15-10 mmfd.	1.00	8832	Housing—Speaker housing complete—Comprising front screws, back dust screen, case and mounting bracket.	3.00
7065	Micarta Screw Driver—Used for I. F. and R. F. adjustment.	1.10	8833	Bracket assembly—Speaker housing bracket, comprising brackets, 2 mounting bolts, 4 washers and 4 nuts.	.95
7299	Capacitor—745 mmfd.	.70	8838	Cable—Speaker shielded cable less plug.	.55
7421	Capacitor pack—Comprising two 0.5 mfd., one 0.018 mfd., three 0.1 mfd., two 0.25 mfd. and one 4.0 mfd. capacitors in metal container.	5.25			
7422	Transformer—1st intermediate transformer.	2.50			
7423	Transformer—2nd intermediate transformer.	2.50			
7424	Transformer—Output transformer.	1.85			
7425	Transformer—Interstage transformer.	2.20			
7426	Board—Resistor board complete, less resistors, coil and capacitor.	.75			
7427	Cover plate—Intermediate adjustment cover plate—Located on front receiver shield—Package of 5.	.50			
7428	Cover plate—Tuning capacitor trimmer adjustment cover plate—Located on top receiver shield—Package of 5.	.50			
7429	Capacitor—0.625 mfd.—In metal casing with mounting bracket.	2.20			
8821	Capacitor assembly—Tuning capacitor assembly—Comprising 3 variable capacitors, drive bracket, drive shaft, drive shaft and drum—Assembled.	8.60			
8822	Flexible drive shaft—Length 30"	4.90			
8823	Shield—Back cover shield for receiver chassis.	2.05			
8824	Shield—Front cover shield for receiver chassis.	1.10			
8825	Shield—Top cover shield for receiver chassis.	1.15			
8826	Bracket—Receiver chassis mounting bracket complete with two rubber bumpers.	1.20			
8827	Cable—Main cable less plug—From control box to receiver chassis and battery box.	2.20			
8833	Flexible drive shaft—Length 42"	8.65			
8834	Flexible drive shaft—Length 54"	9.35			
8835	Flexible drive shaft—Length 66"	9.65			
8836	Flexible drive shaft—Length 78"	10.10			

Order By Stock Number Only

Order By Stock Number Only

R. C. A. VICTOR CO., INC.

MODEL P-31
Portable
Schematic
Voltage

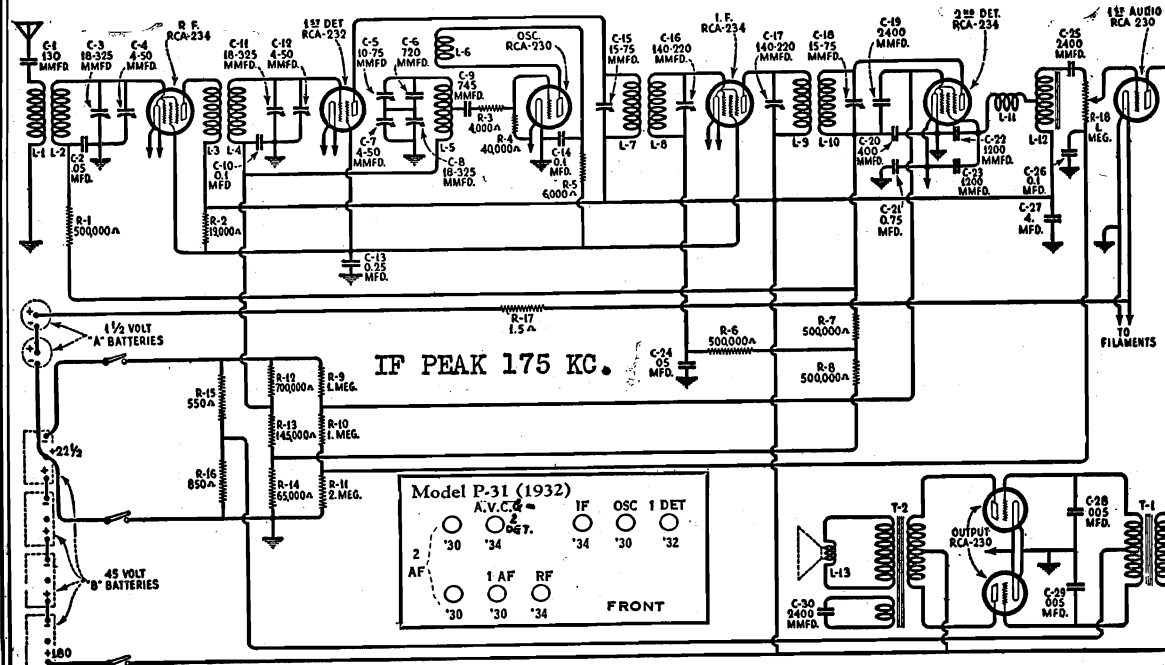

"A" Battery Current.....0.48 Amps.
Average "B" Battery Current...18 M. A.
Type of Audio Output Amplifier...Class "B"
Undistorted Output.....0.75 Watts

RADIOTRON SOCKET VOLTAGES
(No Signal Being Received)

Radiotron No.	Control Grid to Filament Volts	Screen Grid to Filament Volts	Plate to Filament Volts	Screen Current M. A.	Plate Current M. A.	Filament Volts
1. R. F.	0.2	65	150	1.0	3.0	2.0
2. 1st Det.	0.5	65	150	0.1	0.2	2.0
3. Osc.	1.0	—	45	—	3.0	2.0
4. I. F.	0.5	65	150	1.0	3.0	2.0
5. 2nd Det.	2.0	150	-1.5	4.0	0	2.0
6. 1st A. F.	1.0	—	145	—	2.5	2.0
7. Power	14.0	—	150	—	1.5	2.0
8. Power	14.0	—	150	—	1.5	2.0

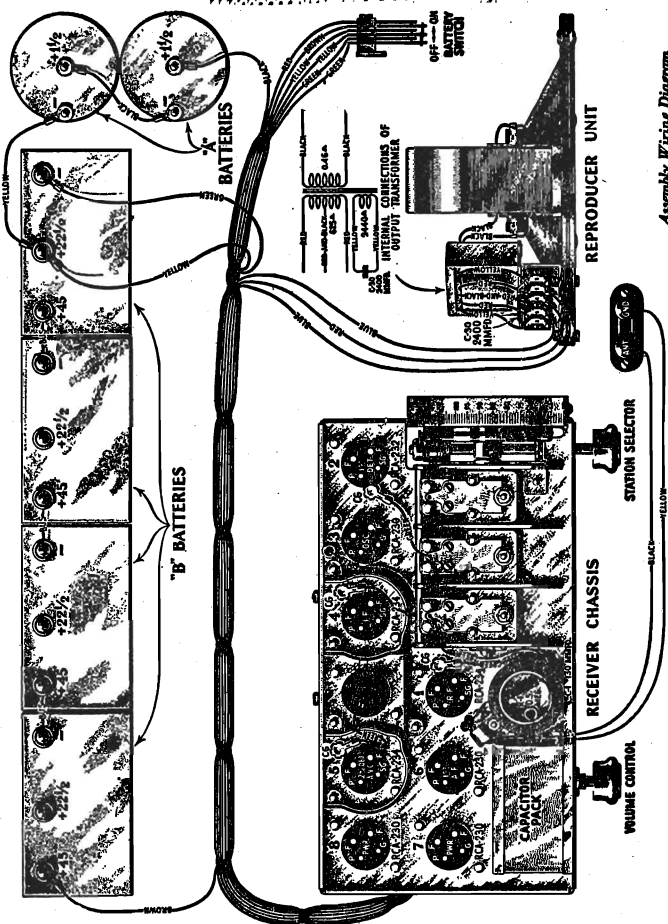

MODEL P-31
Portable
Chassis-Notes

R. C. A. VICTOR CO., INC.

PORTABLE
RADIOLA P-31

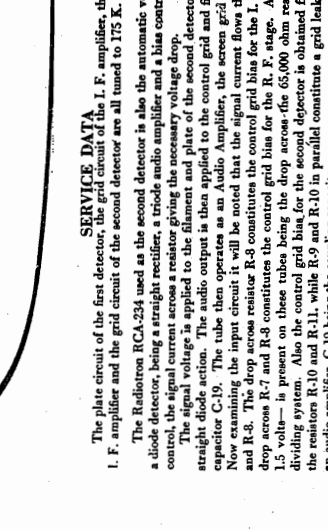
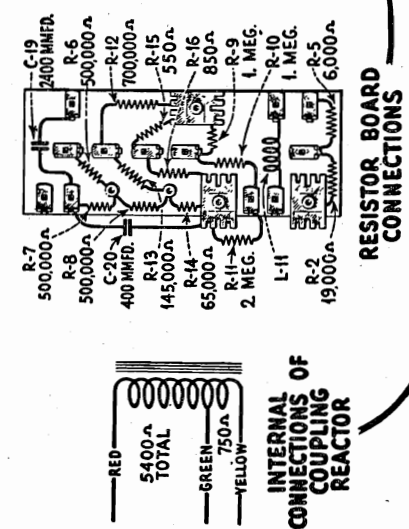
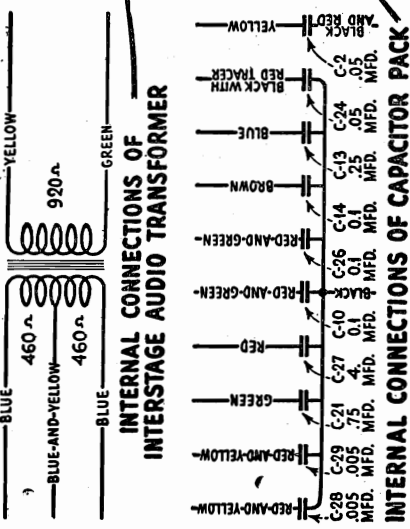
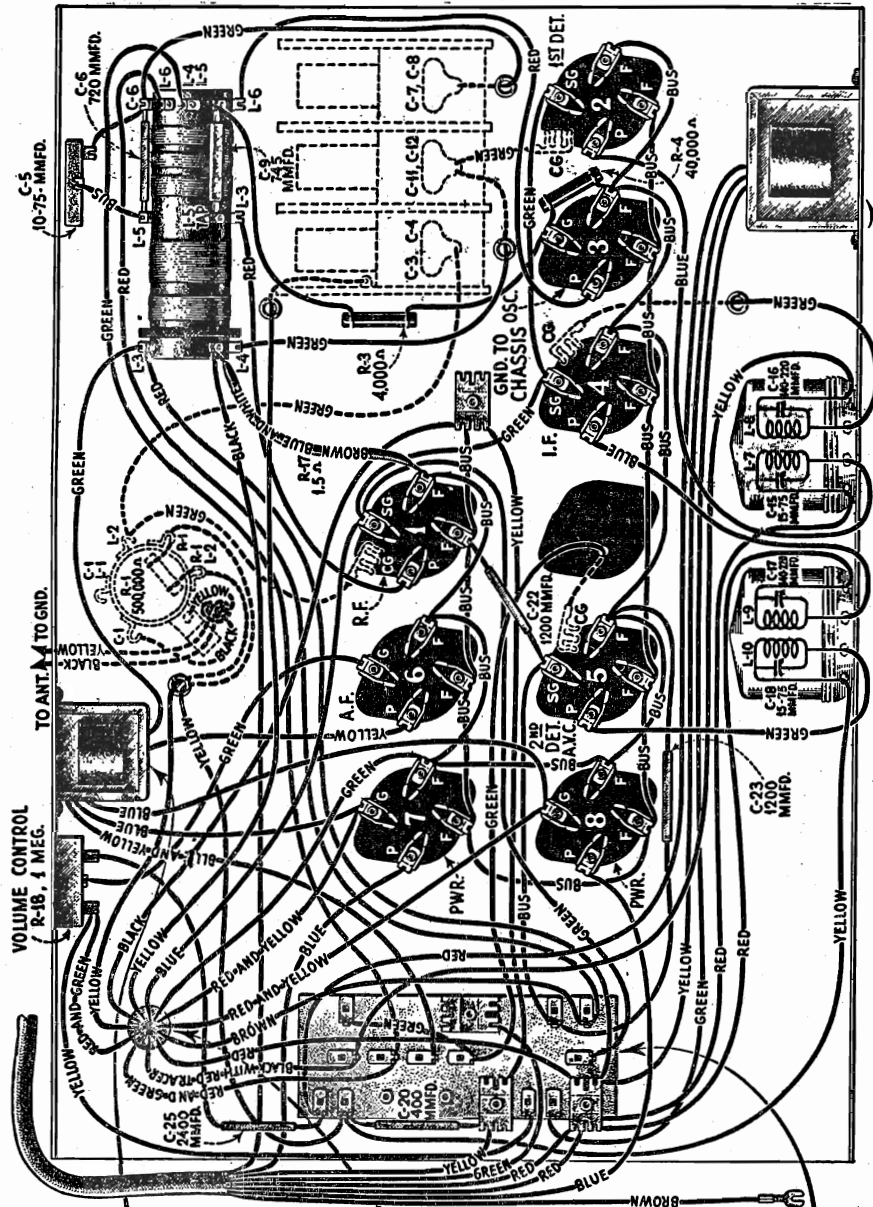

SERVICE DATA
The plate circuit of the first detector, the grid circuit of the I. F. amplifier, the plate circuit of the first A. F. amplifier and the grid circuit of the second detector are all tuned to 175 K. C.
The Radiotron RCA-234 used as the second detector is also the automatic volume control. It is a diode detector, being a straight rectifier, a triode audio amplifier and a bias control automatic volume control, the signal current across a resistor giving the necessary voltage drop.
The signal voltage is applied to the filament and plate of the second detector, being rectified by straight diode action. The audio output is then applied to the control grid and filament by use of capacitor C-19. The tube then operates as an Audio Amplifier, the screen grid acting as the plate for R-7 and R-8. The drop across resistor R-8 constitutes the control grid bias for the I. F. amplifier and the drop across R-7 and R-8 constitutes the control grid bias for the R. F. stage. A small initial bias of 1.5 volts is present on these tubes being the drop across the 65,000 ohm resistor of the voltage dividing system. Also the control grid bias for the second detector is obtained from the drop across the resistors R-10 and R-11, while R-9 and R-10 in parallel constitute a grid leak for its operation as an audio amplifier, C-19 being the coupling capacitor.
The output of the detector is then coupled by means of impedance coupling to the grid of the first A. F. amplifying tube. The grid leak is in the form of a potentiometer which, in the volume control, its action controlling the audio voltage applied to the grid of the first A. F. tube. The output of this tube is then applied to the grids of the two Radiotrons RCA-230 which are connected in Push-Pull as a Class "B" amplifier. The output of this stage is then transformer coupled to the cone coil of the

Permanent magnet dynamic type loudspeaker. An extra winding, shunted by a capacitor, acts as a high frequency cut-off.
Service Data on the RCA Victor Portable Radiola P-31 is similar to that of other RCA Victor Super-Heterodyne receivers. Alignments of the R. F., Oscillator and I. F. stages should be made in a manner similar to that described in the Service Notes on the Automobile Radiola M-30. The location of the various line-up capacitors is the same as that of the M-30.
In making line-up adjustments on the P-31, there is one important feature that affects this operation, that should be remembered. That feature is the automatic volume control. Due to it being a combined A. V. C. and second detector, it cannot be removed from its socket or replaced with a dummy Radiotron.
R. F., OSCILLATOR AND I. F. ADJUSTMENTS
The R. F., Oscillator and I. F. Adjustments in Model P-31 are similar to those of the Automobile Radiola M-30. However, due to the A. V. C. tube also being the second detector, it cannot be removed while line-up adjustments are made. The proper manner in making this adjustment is as follows:
(a) Set the volume control of the receiver at maximum.
(b) Reduce the output of the external oscillator or its coupling to the receiver until a definite reduction in output meter reading is obtained. The oscillator output should again be reduced until but a slight indication in the output meter is obtained. At this low input the A. V. C. action is not sufficiently flat to interfere with the proper alignment of the various circuits.

RCA-VICTOR CO., INC.

MODEL M-32
Installation Notes
Part 1

INTRODUCTION

This automobile radio receiver utilizes a highly-efficient six-tube Superheterodyne circuit, a remote control unit, and a newly-designed electrodynamic loudspeaker. Because of the inherently adverse conditions to which an instrument of this type is subjected, more attention should be given to its installation than is required by a modern radio for the home. Comparable performance, however, will be obtained if these instructions are carefully followed, both with respect to installation and operation.

Three new-type Radiotrons are used: (1) the "r-f exponential pentode" RCA-39, (2) the "duodiode triode" RCA-85, and (3) the "a-f power pentode" RCA-89. These tubes incorporate the most recent engineering features and contribute materially to the outstanding performance of this receiver. An innovation in design is found in the use of Radiotron RCA-85 which combines automatic volume control with the normal function of the second detector in a single stage.

The receiver unit is extremely compact and is enclosed by a metallic shield case. The case may be quickly detached from its mounting bolts, thereby affording maximum convenience in replacing Radiotrons or other servicing. The remote control unit

is arranged for clamping to the steering column and thus places the volume and tuning controls and the key-operated power switch readily accessible to the driver. The dial scale, located only slightly below the normal driving line of vision, is glare-proof illuminated and is calibrated to facilitate frequency selection.

High-quality reproduction is obtained by use of the new electrodynamic loudspeaker. This unit is protected against mechanical injury by enclosure in an acoustically correct and attractive metallic container equipped with tone equalizers.

Plate voltage supply for the Radiotrons is obtained from an economical "B" battery eliminator unit which is furnished as a part of the standard equipment. (A special companion model of this receiver without the eliminator and suitable for operation from external "B" batteries, is available if preferred. See Appendix I.) Equipment for the suppression of ignition interference is included with the instrument.

The use of a roof antenna in all installations is recommended. Satisfactory results in many cases, however, may be obtained with a plate-type antenna mounted beneath the floor of the car.

PART I—INSTALLATION

Equipment

A. Equipment Furnished:

1. Receiver Unit—complete with the following Radiotrons:
 - (a) Three RCA-39.
 - (b) One RCA-37.
 - (c) One RCA-85.
 - (d) One RCA-89.
2. Loudspeaker—with cable and connector plug, washer, and nuts (2).
3. "B" Battery Eliminator Unit.
4. Outfit Package—containing:
 - (a) Remote Control Unit—with bracket, felt, screws, and interconnecting cable.
 - (b) Switch Keys (2) and Fuse—packed in Instruction envelope (attached to control knob of item a).
 - (c) Flexible Shafts (2) and Set Screws (6).
 - (d) Antenna Coupling Connector Sleeve.
 - (e) Mounting Brackets (4) (for receiver and "B" battery eliminator units)—complete with screws (8), bolts (8), nuts (16), washers (8), and lockwashers (8).
 - (f) Insulation Bushing (for cable entrance slot in "B" battery eliminator unit).
 - (g) Wiring Clamp (for loud-speaker cable).
 - (h) Ignition Interference Suppression Equipment:
 - 6 Sparkplug type suppressors (additional obtainable from your Dealer).
 - 1 Distributor type suppressor.
 - 2 Capacitors.
 - (i) Instruction Book

B. Additional Equipment Required:

1. Antenna—

- (a) Roof (built-in) type recommended.
- (b) Plate (sub-mounted) type—alternative. A special plate antenna complete with mounting clamps, studs, and lead-in wire is obtainable from your Dealer, if required.

Location of Units

The arrangement of units shown in Figure 1 is applicable to the majority of automobiles. In certain installations, however, such locations may be considered impractical or not in accordance with personal preference, thereby necessitating a slight change in layout. The following suggestions will be of assistance in determining the most suitable position for each unit in any given case.

Receiver and Loudspeaker—In mounting these units, the adaptability of both to bulkhead (the partition between the engine and driving compartments) suspension should be determined initially. Consideration should be given to the space available and to the possibility of interference of the units with other equipment beneath the instrument panel or of the mounting bolts with apparatus on the engine side of the bulkhead.

Remote Control Unit—The control unit should be mounted on the steering column in a position chosen to afford greatest accessibility.

MODEL M-32

Installation Notes
Part 2

RCA-VICTOR CO., INC.

Antenna—

Roof Type: Best results will be obtained by use of a roof antenna. The majority of modern automobiles (closed body types only) are already equipped with such an antenna installed at the factory, the lead-in wire from which will usually be found coiled up beneath the instrument panel. Many other earlier cars employ a piece of metallic screen—for top material support—which, if ungrounded (not in electrical contact with the metallic frame), may be readily utilized as an antenna.

NOTE—The presence of a top support screen and of grounds in that screen may be determined without removing any portion of the top fabric. Consult your Dealer as to the proper procedure for making this test.

In order to use an ungrounded support screen, one corner only of the head-lining need be removed. A shielded lead should be first soldered to the screen and then carried down the front pillar post nearest the receiver unit. Its shield covering must be soldered or bonded to the car frame prior to replacement of the head lining.

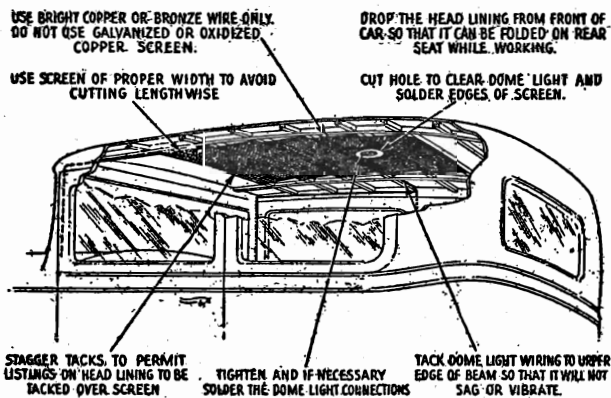

Figure 2

If the top support screen is grounded, or if no screen is present, it will be necessary to remove the entire head-lining (see Figure 2). In the former case, the screen may be insulated by removal of a strip several inches from all edges and from the dome light fixture. The possibility of subsequent shifting may be eliminated by tacking the screen to one of the ribs and by lacing the sides with cord. Where no support screen is used, a copper screen having a total area of at least ten square feet should be inserted. It should be located as far to the rear as possible and insulated from all metallic parts grounded to the frame of the car. The lead-in wire may then be attached as noted above and the head-lining replaced.

NOTE—Since a degree of skill—only acquired by experience—is necessary in removing and replacing the top fabric material, such work should be allotted to a competent “trim” man.

Plate Type: For those cases where the installation of a roof antenna is considered impractical or too costly, satisfactory reception from local or semi-

distant powerful stations may be obtained by use of the special, plate-type antenna. This unit should be clamped to the frame of the chassis as far to the rear as possible. It is adjustable in length and may be mounted either lengthwise or crosswise of the chassis which position should be selected with due regard to the prevention of overcrowding. The plate must be placed as close to the ground as possible, but not below the lowest portion of the chassis at the desired location as sufficient road clearance must be retained. It is also important to avoid any position in which the plate will impede free motion of chassis parts such as springs, drive shaft, or axles in order to prevent antenna damage.

“B” Battery Eliminator—The “B” battery eliminator may be mounted at any convenient position in the car. It is preferable, however, to place this unit near the receiver and to use bulkhead suspension when sufficient space is available. To conserve mounting space, the eliminator may be fastened to the engine side of the bulkhead but, in such cases, it is important that the unit be located as far as possible from the exhaust manifold.

Mounting the Units

Details of mounting the various units are shown in Figure 1. The following procedures are recommended:

Receiver Unit—Assemble the mounting brackets (packed in receiver carton) to the rear of the shield case by means of the machine screws furnished. Support the unit in the proper location, allowing a clearance of at least one inch above the top surface to permit ready removal for servicing. On the proposed mounting surface mark the outlines of the four key-hole shaped, bracket slots. Then drill four $\frac{3}{8}$ inch holes, coinciding with the top of the slot markings, and insert the receiver mounting bolts loosely.

The front cover of the receiver unit case (held in place by four screws) must now be removed and all packing material—inserted for protection of the Radiotrons during shipment—withdrawn. Make certain that all tubes are in position and that the control grid clips are pressed down firmly over the respective dome terminals as shown by the diagram printed on the label affixed to the top of the case. Rotate the tuning control shaft until the plates of the variable capacitor are fully meshed and adjust both shafts to positions wherein the flatted portions face upward. Then replace the front cover and tighten the cover screws in place.

NOTE—In order to further examine the radio chassis, that unit may be withdrawn from the body of the case subsequent to the removal of three screws from the lower surface. The antenna lead and the associated shield pigtail, however, must first be passed through the case side—which operation may be facilitated by detaching the small rubber bushing secured in the entrance opening.

RCA-VICTOR CO., INC.

MODEL M-32
Installation Notes
Part 3

Remote Control Unit—Detach the cover of the remote control unit by removing the push-on knobs, the knurled switch-retaining nut and the two front screws. Then insert the free end (without small coupling) of each flexible shaft housing through the rear bushings, making certain that each flexible shaft enters and extends the full depth in the drilled hole in the end of the corresponding control shaft. Tighten the control shaft set screws against the flexible shafts and finally secure the rear bushing set screws against each flexible shaft housing. The cover may now be replaced and the assembly rested in an upright position near the receiver unit.

Remove the set screws from the small couplings attached to the opposite ends of the flexible shafts and insert the shaft housings through the openings in the metallic cover plate encasing the tuning and volume control shafts of the receiver unit. *These shafts must be so inserted as to be crossed in the final assembly as indicated by Figure 1.* Make certain that the couplings are fully engaged over the receiver control shafts and then tighten the cover plate screws against each flexible shaft housing. Turn the control knobs on the remote control unit until the threaded openings for the coupling set screws (visible through slots in cover plate bushings) are at the top and line up with the flatted portions of the receiver unit control shafts. Finally, insert and tighten both coupling set screws.

Receiver and Remote Control Assembly—Hang the receiver unit in position over the mounting bolts and tighten those bolts in place. Then attach the remote control unit to the steering column by means of the clamp and screws provided. In order to prevent damage to the finish, the felt provided should first be wrapped around the column at the desired location and fastened with tape. After completing these operations, slowly rotate the Station Selector to each extremity of the dial, in turn, to insure use of the complete range.

NOTE—In some installations it will be found necessary or desirable to shorten the flexible shafts. This may be accomplished as follows: (1) Remove the shafts from the housings; (2) cut the housings to the proper length with a hack-saw; (3) re-insert the shafts in the housings as far as possible, so that the couplings at the receiver end of the shafts are in contact with the housings; (4) solder the protruding end of each shaft, to prevent unwinding when cut, at a point $27/32$ inch beyond the end of its housing (*Important—A large soldering iron must be used to insure thorough penetration of the solder through the shaft for a distance of about one quarter inch on either side of the cutting point—use only non-corrosive soldering flux*); (5) cut each soldered shaft with a hack-saw or pliers at the point mentioned—namely, $27/32$ inch (as accurately as possible) from the end of the housing; (6) remove all burrs from cut ends.

Loudspeaker—Place the loudspeaker with its cone opening against the proposed mounting surface

and mark an outline of the rectangular container. Determine the exact center of this area by drawing in the diagonals and mark that position with a center-punch. Next drill a $1/2$ inch hole at the center-punch mark and mount the loudspeaker by means of the threaded stud attached to its rear bracket. In hanging this unit, choose that position wherein the cable entrance opening is at the top.

Plate Antenna—The plate antenna, if used, should be bolted to the channel members of the automobile chassis by means of the clamps provided (see Figure 1 and notes under "Location of Units"). A shielded lead-in wire is provided with this assembly which should be brought into the driving compartment of the car through a $1/2$ inch hole drilled in the toe-board if no other opening is available. The fully-shielded end of this wire is to be connected to the receiver unit antenna lead by means of the coupling type connector, as described under "Connections—Antenna to Receiver." Cut off the opposite (unshielded) end as required for connection to the plate and to eliminate excessive slack. The pig-tail extension from the end of the shield should be soldered or securely bonded to the frame of the car.

"B" Battery Eliminator—The "B" battery eliminator is arranged for mounting in a manner similar to that employed for the receiver unit. It is important that this machine be mounted so that the internal rotating shaft will be horizontal in assembly.

Connections

Refer to Figure 1 and make connections as follows:

Main Wiring Cable—The main wiring cable for connection between the independent units of this instrument (attached to the remote control unit during shipment) should be connected as indicated graphically. If necessary, make a loop in this cable to eliminate excessive slack and tape securely.

The power input lead contained in this cable (single shielded conductor with lug) must be connected electrically to the ungrounded side of the car storage battery, preferably at the battery terminal of the ammeter. The shield pigtail of the power input lead should be soldered or securely bonded to the instrument panel or frame of the car.

Electrical connections to the "B" battery eliminator unit are accomplished by means of the five-conductor group extending from the main wiring cable. The individual (color coded) leads are to be connected to the internal screw type terminals of the eliminator unit (rendered accessible by removal of the sheet metal case) as shown in Figure C. Appendix II. *Prior to making these connections determine which side of the car storage battery is grounded. If the positive terminal is grounded, reverse the two leads—both from same end of dynamotor—connected to terminals 1 and 3 of filter, as indicated in Figure C.*

NOTE—The insulation bushing (contained in Outfit Package) should first be slipped over

MODEL M-32

Installation Notes

Part 4

RCA-VICTOR CO., INC.

the five leads and, when replacing the cover, secured in the cable entrance slot. The shield pigtail should be brought out through the bushing and fastened beneath the nearest cover mounting screw.

The *special* four prong plug attached to the main wiring cable must be inserted in the corresponding socket located on the left side of the receiver unit and the shield pigtail should be secured beneath a convenient screw in the lower surface of the container.

Loudspeaker to Receiver—The *standard* four-prong plug attached to the loudspeaker cable must be inserted in the remaining socket located on the left side of the receiver unit. The pigtail extending from the cable shield should be secured beneath that container screw to which the shield extension from the adjacent main wiring cable is attached.

Antenna to Receiver—The shielded lead-in wire extending from the roof or plate antenna should be cut to a length sufficient to facilitate attachment to the coupling type connector (secured to the receiver antenna lead) and to eliminate excessive slack. Refer to the detailed view of this coupling connector in Figure 1, which shows clearly the connections to be made as follows:

The small copper sleeve (packed in Outfit Package) should be slipped over the shield braid of the lead-in wire and the small internal insulated conductor passed through the female portion of the coupling type connector. Solder this conductor securely to the end of the internal eyelet. Then slip the sleeve forward to a position wherein the adjacent ends of the connector and the shield braid are covered. Finally solder the sleeve both to the coupling and to the shield and connect the assembly to that portion secured to the receiver antenna lead. Make certain that the shield pigtail extending from the antenna entrance bushing in the receiver container is securely fastened beneath one of the cover screws.

Suppression of Ignition Interference

(1) Disconnect all wires from the spark plugs. Fasten one spark plug suppressor to the top of each plug and re-attach the wires to the free ends of the suppressors.

(2) If the distributor is of the plug-in type, disconnect the center wire from the head. Plug the distributor suppressor into the distributor head and insert the wire in the free end of the suppressor.

For cap-type distributors, proceed as follows: Exchange the distributor suppressor at your Dealer's for one of a special type. Cut the wire leading from the distributor to the coil and screw the suppressor into the end attached to the distributor. Screw the other end of the wire (leading to the coil) into the opposite end of the suppressor.

(3) Clamp one of the by-pass capacitors against the generator frame. The screw holding the cut-out ordinarily may also be utilized for securing this unit. Connect the capacitor lead to the terminal on the generator side of the cut-out switch. (In some cases, interference will be reduced by connecting the capacitor lead to the opposite side of the cut-out. The most suitable position for this lead must be determined by trial.)

(4) Clamp the other by-pass capacitor securely to the instrument panel (if metallic) or to a convenient portion of the metal frame of the car, and connect the capacitor lead to the battery side of the ammeter (usually the terminal with only one lead). In certain cases, interference will be reduced by connecting the lead of this capacitor to the battery side of the ignition coil instead of to the ammeter.

(5) It may be found necessary to secure the loudspeaker cable beneath the grounding clamp (packed in Outfit Package) in order to minimize ignition interference. This clamp (as shown in Figure 1) may be attached conveniently to the left side of the receiver container.

PART II—OPERATION

The instrument should be operated as follows:

1. Insert the key in the lock on the Control Unit and turn it to the "on" position clockwise.
2. Set the Volume Control (left-hand knob) at or near the extreme clockwise position. Then turn the Station Selector (right-hand knob) in either direction until a station is heard. (Note—The dial scale is calibrated in channels to aid in station identification. Add one cipher to the scale marking to obtain the actual frequency in kilocycles.)
3. After receiving a signal, turn the Volume Control counter-clockwise until the volume is reduced to a low level. Now, re-adjust the Station Selector to the position midway be-

tween the points where the quality becomes poor or the signal disappears. *This operation insures the best quality of reproduction.*

4. Finally, advance the Volume Control (clockwise) until the desired level is obtained. Except on weak signals, the automatic volume control will maintain the volume substantially at the latter level, thereby precluding further manual adjustments. (Fading of the signal may be experienced in extreme cases, as when passing under bridges or other metallic structures, since such structures almost completely shield the antenna.)
5. When through operating, turn the key to the "off" position, counter-clockwise. The instrument is then locked by removing the key.

RCA-VICTOR CO., INC.

MODEL M-32
Battery Operated
Terminal Data

APPENDIX I—"B" BATTERY OPERATED MODEL

As noted in the Introductory section, a special instrument is available for "B" battery operation. This receiver is identical to the standard model except that the "B" Battery Eliminator Unit is omitted and a specially designed interconnecting cable is used. For such operation, four 45 volt "B" batteries are required and may be obtained from your Dealer.

The following parts are furnished as standard equipment with the battery operated receiver:

- 1 Fuse (rated 0.50 amp.)
- 2 Fuse Leads (with clips)
- 1 Fuse Insulation Sleeve
- 3 Battery Jumper Wires

Certain body types, such as coupes or sedans, afford sufficient space to permit internal mounting of the batteries. In these cases, it is necessary only to clamp the units in a manner to prevent injury or grounding through undue motion while the car is in operation. In such installations, the batteries will probably be most conveniently stacked "end to end" as shown in Figure 3.

For other installations, a special battery box for external mounting (also available from your Dealer) will probably be found necessary or desirable. This box (as shown in Figure 1) may be located at any position under the floorboards of the vehicle except near the exhaust line or where interference with free-moving parts of the chassis will be encountered. If placed in close proximity to the exhaust pipe or muffler, the heat radiation therefrom will cause rapid

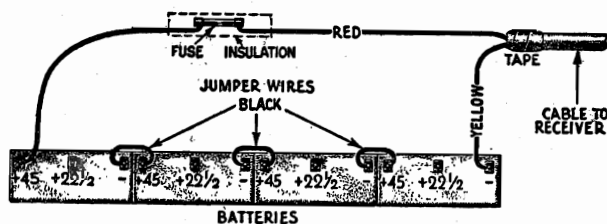

Figure 3

deterioration of the batteries. The box is of suitable dimensions to accommodate the following types of "B" batteries:

- Eveready—No. 485, No. 772, No. 796
- Burgess—No. 2305, No. 2308, D-308
- General—"Flying Squad" V 30 DX

If the battery box is used, it may be mounted most conveniently by drilling the required four (4) three-eighths inch holes in the floorboard with the box cover serving as a template. Insert the four

carriage bolts from above and fasten the box cover (with the hanger bolts inserted) in position beneath the floorboard with the nuts and lockwashers provided. Place the "B" batteries in the box and make all necessary internal connections (see Figure 4). With the fibre spacers in position above the batteries and the nuts on the hanger bolts unscrewed to the ends, lift the battery box into place, swing the hanger bolts into the case brackets and tighten all nuts. Make certain that both nuts are on each bolt and locked tightly. These operations, naturally, will be facilitated by placing the car on a lift.

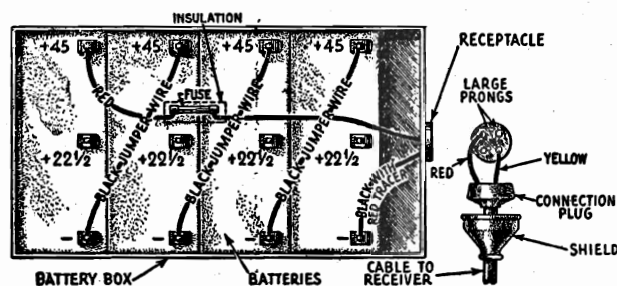

Figure 4

With the battery operated receiver, it will be noted that a plate circuit fuse must be employed. If the cable is to be connected directly to the batteries, the metal braid on the outside of the cable must be pushed back for a short distance in order to obtain leads of suitable length. As indicated in Figure 3, one fuse lead must be soldered to the cable wire and taped and the other connected to the end battery. The leads are equipped with clips (to permit ready replacement of the fuse) which in assembly are protected by an insulation sleeve. The end of the cable should be wrapped with tape for a short distance in order to prevent fraying and grounding to the battery terminals.

If the battery box is used, slip the rubber cover and the plug cap over the cable and solder the leads into the connection plug as indicated in Figure 4. Then fasten the cap to the plug, push the rubber cover forward and insert in the receptacle. One of the fuse leads must be connected to the proper terminal of the receptacle and the other to the end battery.

Worn out "B" batteries cause noisy and weak reception. Renew the batteries when they fail to give a reading of at least 35 volts per block as indicated by a high resistance voltmeter with the set turned "on."

MODEL M-32
Service Data
Voltage

RCA-VICTOR CO., INC.

APPENDIX II—SERVICE DATA

Electrical Specifications

Radiotrons Required
1 RCA-237, 3 RCA-239, 1 RCA-85, 1 RCA-89, Total—6
"A" Battery Consumption—Loudspeaker1.35 Amperes
Receiver2.15 Amperes
Converter3.0 Amperes

Plate Power Consumption35 M. A.
Undistorted Output1.25 Watts
Intermediate Frequency175 K. C.
R. F. Line-up Frequency1400 K. C.
Oscillator Line-Up Frequency1400 Only

This six tube automobile receiver gives excellent performance in respect to sensitivity, selectivity and tone quality. When used with the converter unit, operation entirely from the car battery is obtained.

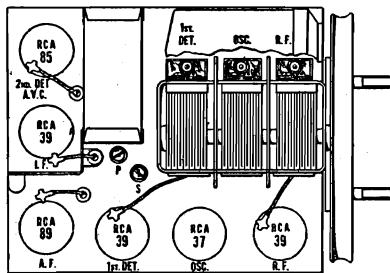

Figure A—Location of Radiotrons and Line-up Capacitors

Line-up Capacitor Adjustments

The receiver must be removed from its metal case to permit correct adjustment of the line-up capacitors. After being removed, a grounded metal plate must be provided for the receiver to rest upon, otherwise the adjustments will be found to be incorrect when the assembly is returned to its metal case. After removal from its case and placing upon the metal plate, proceed as follows:

I. F. Line-up Capacitor Adjustment—The I. F. Amplifier uses two transformers, one being of the untuned variety and one having each of its windings tuned by means of two adjustable capacitors. Figure A shows the location of these capacitors.

- Procure a modulated oscillator giving a signal at 175 K. C. and having its output adjustable. A non-metallic screwdriver such as Stock No. 7065 is necessary together with an output meter.
- Remove the receiver from its case, place it in operation and connect the output of the oscillator between the control grid and ground of the first detector. Remove the oscillator tube and connect the output meter—preferably a thermo-galvanometer—across the voice

coil of the loudspeaker. Then with the volume control at maximum, reduce the oscillator output until a small indication is obtained. Unless this is done, the action of the A. V. C. will make it impossible to obtain correct adjustments.

- Adjust the secondary and then the primary of the I. F. transformer until a maximum deflection is obtained in the output meter. This is the correct adjustment.

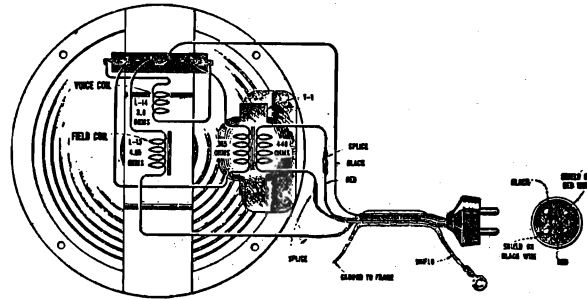

Figure B—Loudspeaker Wiring Diagram

R. F. Line-up Capacitor Adjustment—The R. F., 1st detector and oscillator stages are aligned at 1400 K. C. A modulated oscillator giving a signal at 1400 K. C. a socket wrench and an output meter are necessary for correctly making these adjustments.

- Remove the receiver from its metal case and place on a grounded metal plate. Connect the tuning control and place in operation. Connect the output of the oscillator between antenna and ground. Connect the output meter across the voice coil of the loudspeaker.
- Place the oscillator in operation at 1400 K. C. and adjust its output so that a small deflection is obtained when the receiver volume control is at maximum and the dial set at 1400. Then adjust the three line-up capacitors until a maximum deflection is obtained. This is done by means of a socket wrench.

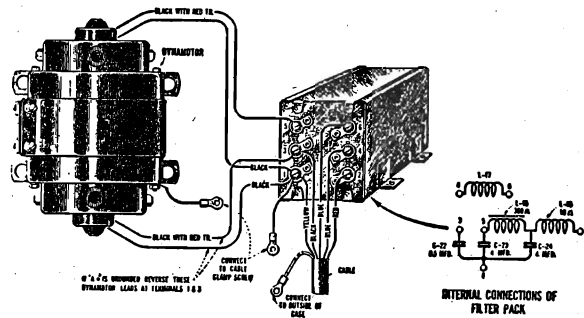

Figure C—Plate Supply Unit Wiring

RADIOTRON SOCKET VOLTAGES

Radiotron No.	Cathode or Filament to Control Grid Volts	Cathode or Filament to Screen Grid Volts	Cathode or Filament to Plate Volts	Plate Current M. A.	Filament or Heater Volts
1. R.F. RCA-39	0.9	71	177	4.5	5.2
2. 1st Det. RCA-39	6.0	67	172	1.35	5.2
3. Osc. RCA-37	—	—	72	5.5	5.2
4. I.F. RCA-39	0.9	71	177	4.5	5.2
5. 2nd Det. and A.V.C. RCA-85	—	—	175	4.5	5.2
6. P.W.R. RCA-89	18	178	160	18.0	5.2

Voltages are those at which Radiotrons are operating and with no signal impressed on input

OTHER IMPORTANT VOLTAGES

Battery Voltage6.0 Volts
Input to Dynamotor5.75 Volts
Battery Drain5.5 Amperes
Output from Dynamotor178 Vc at 34.5 M.A.
Loudspeaker Field Drain1.35 Amperes

RCA-VICTOR CO., INC.

MODEL M-32
Chassis Wiring

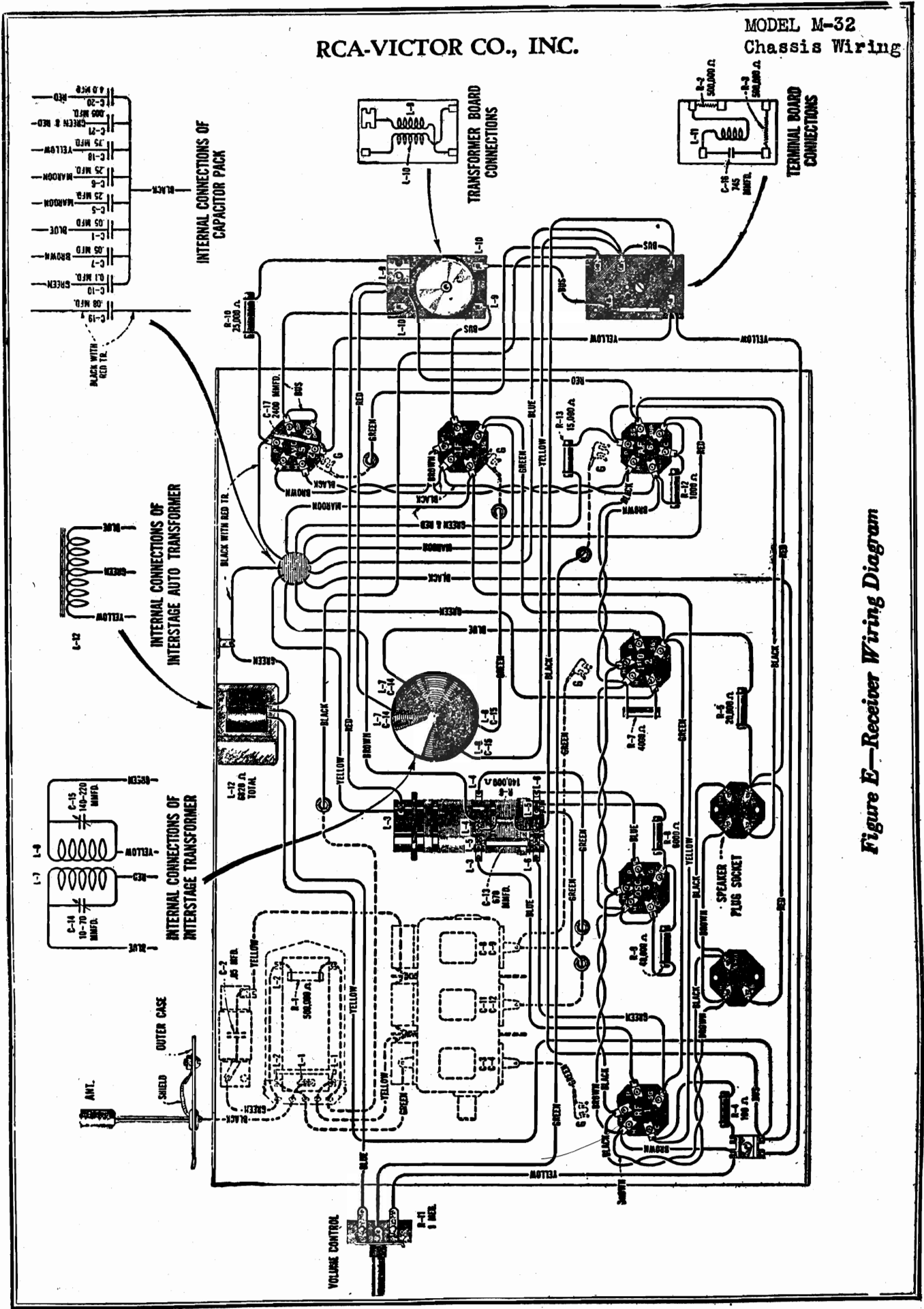

Figure E—Receiver Wiring Diagram

RCA-VICTOR CO., INC.

MODEL M-32
Parts List

REPLACEMENT PARTS

(Replacement Parts May be Purchased from Authorized Dealers and Distributors Only)

Stock No.	DESCRIPTION	List Price	Stock No.	DESCRIPTION	List Price
RECEIVER ASSEMBLIES					
2734	Capacitor—745 mmfd.—Package of 5.....	\$2.20	3465	Cable—Antenna lead-in shielded cable.....	\$0.35
2747	Contact cap—Package of 5.....	.50	3466	Connector—Antenna lead-in connector.....	.60
2749	Capacitor—2,400 mmfd.....	1.50	3491	Washer—Rubber insulating washer—Used with insulator No. 6131—Package of 4.....	.25
2816	Resistor—1,000 ohm—Carbon type— $\frac{1}{2}$ watt—Package of 5.....	2.50	6129	Staple—Insulated staple—Package of 100...	.75
3264	Resistor—25,000 ohms—Carbon type— $\frac{1}{2}$ watt—Package of 5.....	2.00	6130	Screw and nut—U bracket set screw— $\frac{1}{4}$ —16 x 1—Complete with lock nut—Pkg. of 10.	.50
3442	Resistor—100 ohms—Carbon type— $\frac{1}{4}$ watt—Package of 5.....	1.00	6131	Insulator—Insulator bushing for No. 7420—Package of 10.....	.70
3443	Resistor—140 ohms—Carbon type— $\frac{1}{4}$ watt—Package of 5.....	1.00	6381	Cable—Shielded antenna cable—For use with antenna plate.....	2.94
3447	Coil—Automatic volume control coupling coil.	.66	7419	Bracket—U bracket for mounting antenna plates—Package of 2.....	1.60
3448	Cord—3 gang tuning capacitor drive cord...	.50	7420	Stud—Antenna plate stud— $\frac{1}{4}$ —16 x 8 $\frac{1}{2}$ —Complete with 5 mounting nuts—Pkg. of 5.	1.90
3454	Scale—Dial Scale.....	.54	8819	Plate—Single antenna plate.....	1.75
6114	Resistor—20,000 ohms—Carbon type—1 watt—Package of 5.....	2.00	MISCELLANEOUS PARTS		
6143	Resistor—40,000 ohms—Carbon type— $\frac{1}{4}$ watt—Package of 5.....	2.00	6148	Fuse—10 amperes—Package of 5.....	.50
6186	Resistor—500,000 ohms—Carbon type— $\frac{1}{4}$ watt—Package of 5.....	2.00	6151	Suppressor—Spark plug suppressor.....	.65
6192	Spring—3 gang tuning capacitor drive cord tension spring—Package of 10.....	.50	6152	Suppressor—Distributor suppressor.....	.65
6241	Resistor—140,000 ohms—Carbon type— $\frac{1}{4}$ watt—Package of 5.....	2.00	6169	Felt—Felt strip for steering column—Pk. of 10.	.50
6243	Resistor—6,000 ohms—Carbon type— $\frac{1}{4}$ watt—Package of 5.....	2.00	7065	Screwdriver—Non metallic Screwdriver—For line-up adjustments.....	1.10
6250	Resistor—4,000 ohms—Carbon type— $\frac{1}{2}$ watt—Package of 5.....	2.00	7429	Capacitor—0.625 mfd. capacitor in metal casing with mounting bracket.....	2.20
6300	Socket—4 contact Radiotron socket.....	.55	7553	Cable—Inter-connecting cable complete with male section of connector plug—For eliminator operation.....	2.66
6317	Capacitor—0.05 mfd. capacitor.....	.70	7561	Cable—Inter-connecting cable complete with male section of connector plug—For battery operation.....	2.12
6320	Capacitor—670 mmfd.—Oscillator series capacitor—Package of 5.....	2.50	REPRODUCER ASSEMBLIES		
6358	Socket—3 contact socket.....	.38	6182	Terminal board—Reproducer terminal board with 3 terminals—Package of 5.....	.50
6359	Shield—Radiotron tube shield.....	.36	6364	Transformer—Output transformer.....	2.00
6360	Transformer—First intermediate frequency transformer.....	2.14	8702	Ring—Cone retaining ring.....	.80
6361	Transformer—Second intermediate frequency transformer.....	2.28	8961	Coil assembly—Comprising field coil, magnet and cone support.....	3.34
6362	Shaft—Tuning capacitor drive shaft with two "C" washers.....	.40	8962	Cone—Reproducer cone.....	1.12
6363	Volume control—Complete with mounting nut.	1.38	8963	Bracket—Reproducer mounting bracket complete with washer and nuts.....	.98
6365	Coil—Detector and oscillator coil.....	2.32	8964	Housing—Reproducer housing.....	2.08
6366	Coil—R. F. coil assembly.....	1.60	8965	Screen—Dust screen.....	.40
7484	Socket—UY type Radiotron socket.....	.65	BATTERY BOX ASSEMBLY		
7485	Socket—Radiotron 6 contact socket.....	.70	2968	Receptacle—Four prong receptacle complete.	.50
7545	Transformer—Interstage auto transformer...	2.48	6122	Clamp—Cable clamp—Package of 15.....	.50
7546	Capacitor pack—Comprising one 0.08 mfd., one 0.1 mfd., two 0.05 mfd., two 0.25 mfd., one 0.75 mfd., one 0.005 mfd., and one 4.0 mfd. capacitors in metal container.....	3.58	6123	Plug—Four prong male plug.....	.50
7547	Drum—For 3 gang tuning capacitor.....	.70	6124	Cap—Plug cover rubber cap for #6123—Pk. of 5.	1.50
7548	Capacitor—3 gang variable tuning capacitor assembly.....	3.50	6125	Fuse— $\frac{1}{4}$ ampere—Package of 5.....	.50
CONTROL BOX ASSEMBLIES					
3444	Socket—Dial lamp socket.....	.38	6126	Clip—Fuse clip—Package of 12.....	.50
3445	Shaft—Volume control shaft with "C" washer.	.48	6127	Bolt—Carriage bolt for mounting top of box to car— $\frac{1}{4}$ —18 x 1 $\frac{1}{4}$ "—Complete with lock nut—Package of 5.....	.50
3446	Shaft—Station selector shaft with "C" washer.	.38	7418	Bolt—Hanger bolt $\frac{1}{4}$ —18 x 9 $\frac{1}{2}$ "—Complete with two lock nuts—Package of 5.....	.50
3454	Scale—Dial scale.....	.54	8817	Box body assembly—Comprising bottom plate, 2 side plates, 2 bottom strips and receptacle—Assembled.....	3.45
6158	Nut—Knurled nut for lock switch—Pkg. of 10.	.50	8818	Box cover assembly—Comprising cover plate, 2 strips and 2 rubber strips—Assembled.....	1.70
G5021	Knob—Station selector knob or volume control knob—Package of 5.....	1.50	8820	Plate and strip assembly—Cardboard plate and strip assembly comprising six strips and one plate—Package of 5 sets.....	.75
G5022	Label—Metal trade mark label—Pkg. of 5.	.75	"B" ELIMINATOR ASSEMBLIES		
6164	Key—For lock switch—Package of 10.....	.50	3473	Brushes—One set of 2—For low voltage end of dynamotor.....	1.04
6357	Switch—Lock switch complete.....	1.46	3474	Brushes—One set of 2—For high voltage end of dynamotor.....	.82
7543	Shaft—Volume control or station selector flexible shaft—Approximately 39" long..	1.92	7554	Filter pack—Comprising one 0.5 mfd., two 4.0 mfd. capacitors, one reactor and two choke coils.....	4.87
7562	Shaft—Volume control or station selector flexible shaft—Approximately 51" long..	1.62	7555	Dynamotor complete.....	23.52
7563	Shaft—Flexible shaft—Volume control or station selector shaft—Approx. 27" long..	1.94			
G7842	Cover—Control box cover assembly comprising cover, cover mounting screws, mounting clamp and clamp mounting screws.....	.76			

MODEL Radiola 48
Resistance Data

R. C. A. VICTOR CO., INC.

Between 1 rf P- 2 rf P
2 rf P- 3 rf P
D P- Output P

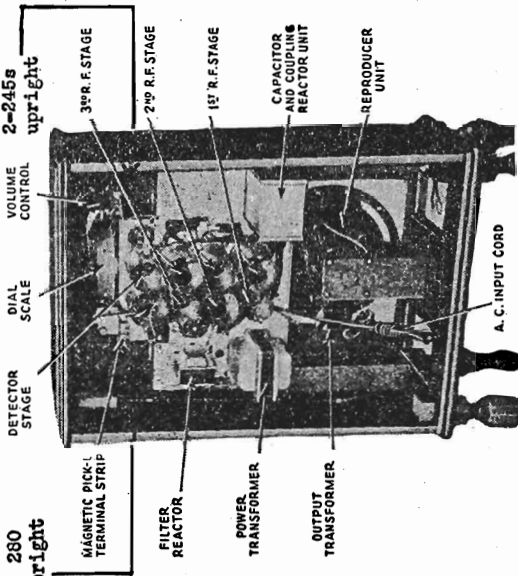

All tubes out of sockets and AC plug removed from power supply line.
Volume Control maximum unless otherwise stated.

From Chassis To

Correct	Incorrect
Aerial (V.C. Min)	50,000 ohms
Aerial (V.C. Max)	30 ohms
1 R-F Control Grid	3 ohms
1 R-F Heater	730 ohms
1 R-F Cathode	120 ohms
1 R-F Screen Grid (V.C.Min)	15,950 ohms
1 R-F Plate	13,917 ohms
2 R-F Control Grid	3 ohms
2 R-F Cathode	120 ohms
2 R-F Screen Grid	16,950 ohms
2 R-F Plate	13,917 ohms
3 R-F Control Grid	3 ohms
3 R-F Cathode	170 ohms
3 R-F Screen Grid	16,975 ohms
Detector Control Grid	13,892 ohms
Detector Cathode	3 ohms
Detector Screen Grid	17,000 ohms
Detector Plate	210,627 ohms
Detector Tube Plate to Plate	24,707 ohms
Detector Tube Control Grid	7,680 ohms
Output Tube Control Grid	430,000 ohms
Output Tube Cathode	430,000 ohms
Output Tube Cg to Cg	860,000 ohms
Output Tube Plate (2 tubes)	17,492 ohms
Output Tube Plate to Plate	930 ohms
'80 Plate	1,895 ohms
'80 Plate to Plate	530 ohms
Field Coil	1,330 ohms
Output Transformer Secondary	.2 ohm
Voice coil only	2.5 ohms

RADIOTRON SOCKET VOLTAGES -- 120-VOLT LINE

Tube No.	Cathode to Heater Volts D.C.	Grid- Screen Grid Volts D.C.	Cathode to Plate Current M. A.	Plate Filament Volts
RF	-40	-2.5	160	3.0
RF	-36	-2.5	155	3.5
RF	-36	-2.5	155	3.5
DET	-28	-7.5	225	0.5
AF	--	* -1.0	200	25.0
AF	--	* -1.0	200	25.0
RF	-40	-1.0	200	0
RF	-40	-1.4	200	0
RF	-40	-0.8	200	0
DET	-28	-8.4	230	.6
AF	--	* -1.0	205	25.0
AF	--	* -1.0	205	25.0

VOLUME CONTROL at MAXIMUM

VOLUME CONTROL at MINIMUM

Disconnect voice coil

MODEL R-50, R-55
 Assembly Wiring
 Voltage

R. C. A. VICTOR CO., INC.

SERVICE DATA

Information pertaining to R. F., Oscillator and I. F. adjustments together with general service data for this type receiver may be obtained from the Service Notes already issued on the RCA Radiola 80.

The beat frequency—175 K. C.—appears in the plate circuit of the first detector which is accurately tuned to 175 K. C. The tube used as a first detector is Radiotron UY-224.

R. F. OSCILLATOR AND I. F. ADJUSTMENTS

A reference to the RCA Radiola 80 Notes will give the details for making correct R. F., I. F. and Oscillator adjustments. However, due to the use of an automatic volume control tube, its action will defeat the use of an output meter. To overcome this, a "dummy" Radiotron UY-227 (one that has one heater prong removed but is otherwise O. K.) should be substituted for the tube in the automatic volume control socket. Do not make any adjustments with this tube removed from the socket. While apparently everything functions in the normal manner, the lack of tube capacity in the circuits will cause an incorrect alignment to be made.

In the RCA Victor Radiola R-50 and R-55 the I. F. transformers are adjusted for maximum output and no attempt at band pass tuning should be made when these adjustments are made.

It will be noted on the early Models of R-50 and R-55 that a small 9 mmfd. capacitor is inserted in series with the oscillator trimming capacitor. This capacitor is not used on later models that have a slightly different dial scale. When replacing a dial scale it may therefore be necessary to short this capacitor. A failure in the capacitor may be remedied either by replacing the capacitor or the dial scale.

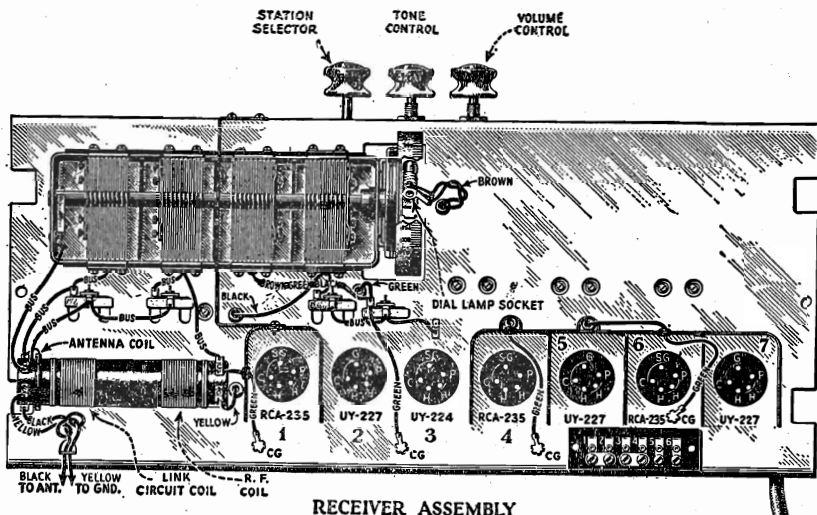

RECEIVER ASSEMBLY

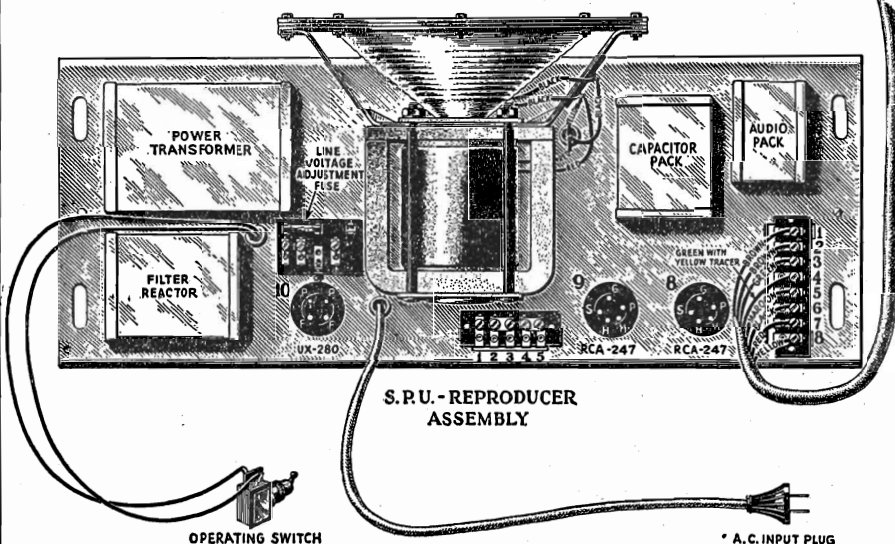

S.P.U. - REPRODUCER ASSEMBLY

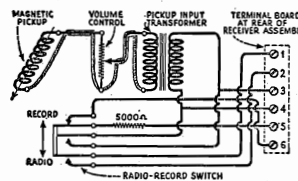

Figure 3—Magnetic Pickup connections

Note: Place the Radio-Record switch and input transformer in the receiver cabinet. Try connecting a wire from receiver terminal No. 6 to input transformer frame or braided shield to pickup and use connection that gives minimum hum.

VOLTAGES ARE THE SAME AT EITHER POSITION OF THE VOLUME CONTROL
 110 VOLT LINE

Radiotron No.	Heater to Cathode Volts	Cathode or Filament or Control Grid Volts	Cathode or Filament to Screen Grid Volts	Cathode or Filament to Plate Volts	Plate Current M. A.	Heater Volts
1. R.F.	2.0	*0.2	60	230	3.5	2.5
2. Osc.	5.0	0	—	50	4.0	2.5
3. 1st Det.	4.0	3.5	60	230	0.5	2.5
4. 1st I.F.	2.0	*0.2	60	230	3.5	2.5
5. A.V.C.	0	0	—	30	0.1	2.5
6. 2nd I.F.	2.0	3.5	60	230	2.5	2.5
7. 2nd Det.	20.0	*8.0	—	210	0.5	2.5
8. Pwr.	—	*10.0	250	235	25.0	2.5
9. Pwr.	—	*10.0	250	235	25.0	2.5

*These readings are not correct due to the resistance in the circuits

Models R-50, R-55, RAE-59 (1931)

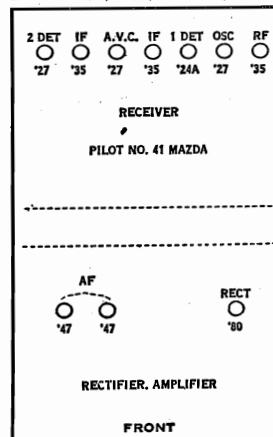

R. C. A. VICTOR CO., INC.

MODEL RAE-59
Schematic

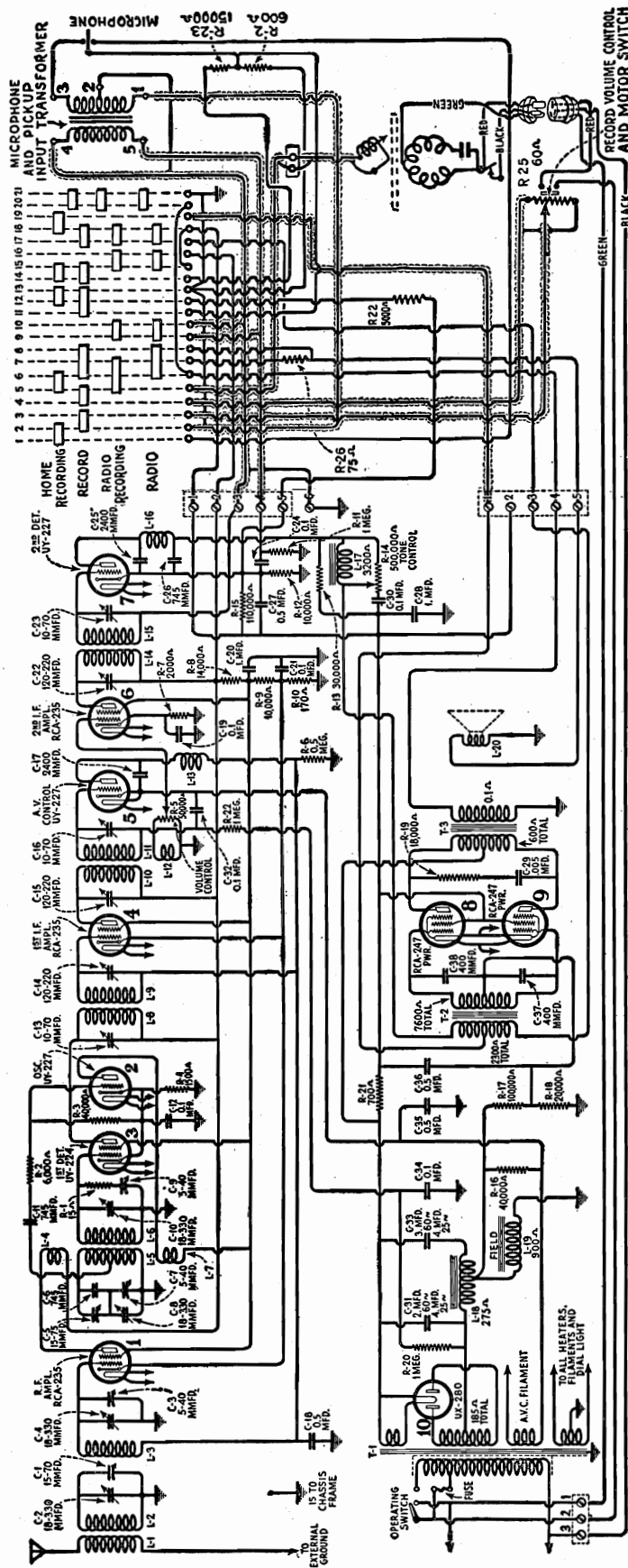

Models R-50, R-55, RAE-59 (1931)

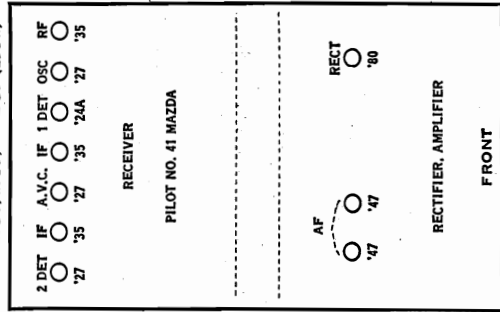

PEAK FREQUENCY-175 KC

The RCA Victor RAE-59 is a Combination DeLuxe Radio and Automatic Phonograph instrument that provides a large variety of home entertainment features. The radio receiver, amplifier and loud-speaker are identical with those used in Models R-50 and 55. The automatic record changing mechanism is of simple, sturdy design and may be operated at 33 1/3 R.P.M. as well as 78 R.P.M.

Excellent home recording is a feature of this instrument, its high quality being due to the use of a two button studio microphone and a high gain amplifier. Also a much greater power output is available, due to the use of Radiotrons RCA-247 in the output stage.

SERVICE DATA

A reference to the R-50 and R-55 Service Notes will give the details of any service work necessary in conjunction with the receiver and amplifier assemblies. Figure 1 shows the schematic wiring diagram and Figure 2 the assembly wiring. A reference to the Service Notes on the RCA Victor Record changing mechanism will give any details of service work in conjunction with this unit.

MODEL RAE-59
Assembly Wiring

R. C. A. VICTOR CO., INC.

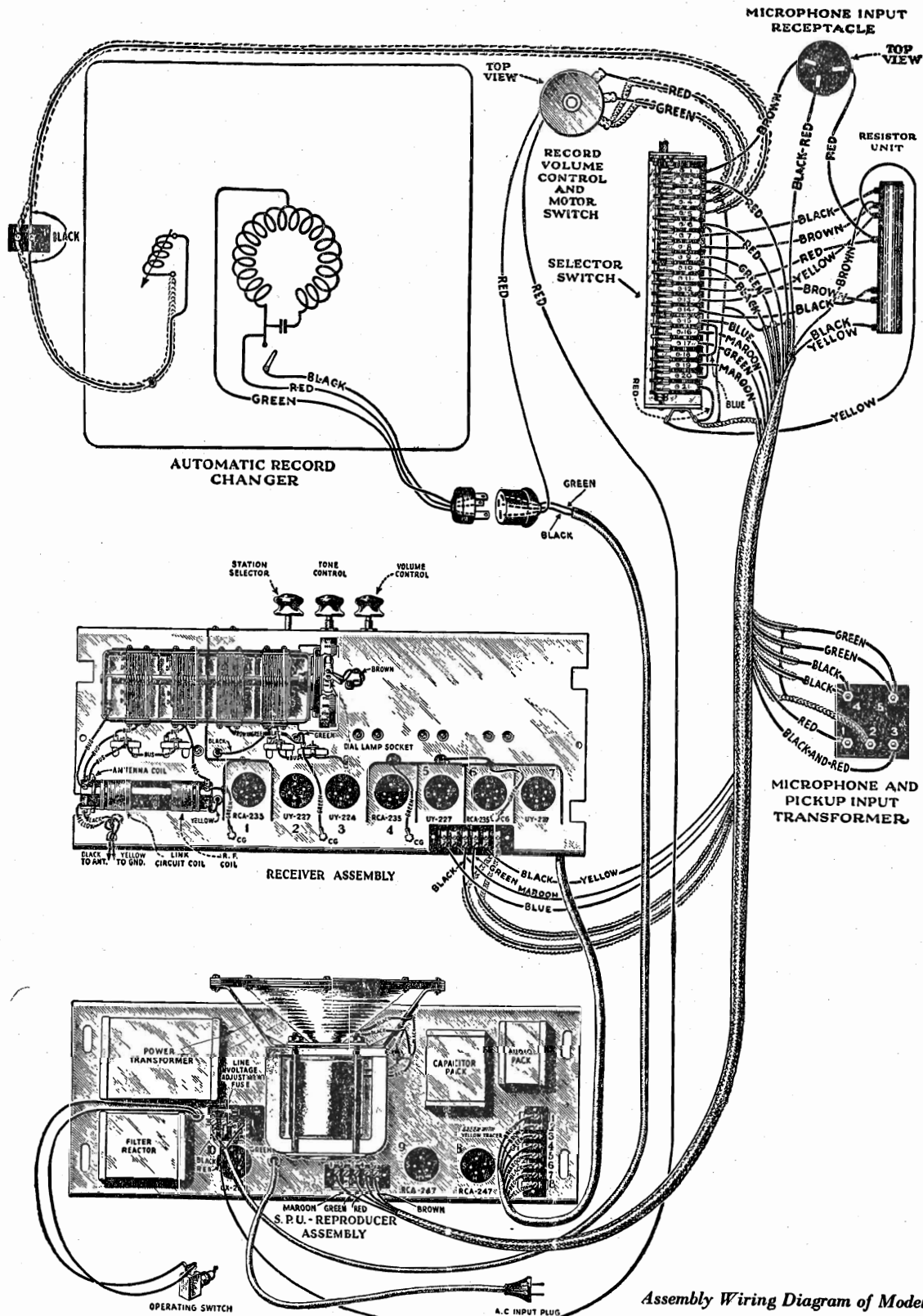

Assembly Wiring Diagram of Model RAE-59

R. C. A. VICTOR CO., INC.

MODEL RE-73
Assembly Wiring

RCA Victor Radiola Electrola RE-73 is an eight tube screen grid tuned R. F. type radio receiver combined with a standard Electrola mechanism. The receiver assembly and amplifier of this model is similar to that used in the 1930 Victor Receivers, Models R-35, R-39, and RE-57. The loudspeaker used is similar to that employed in the RCA Victor Superette R-7.

A reference to the RCA Radiola 86 Service Notes will give the details of any service work necessary in conjunction with the motor board assembly.

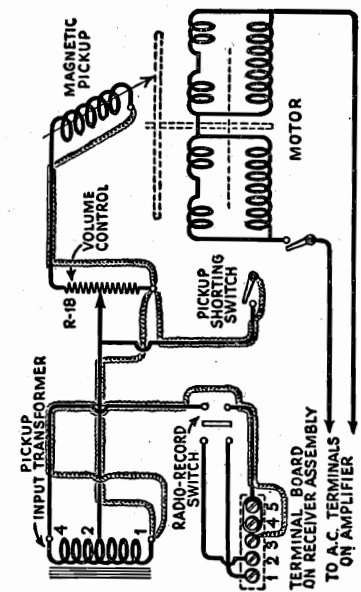
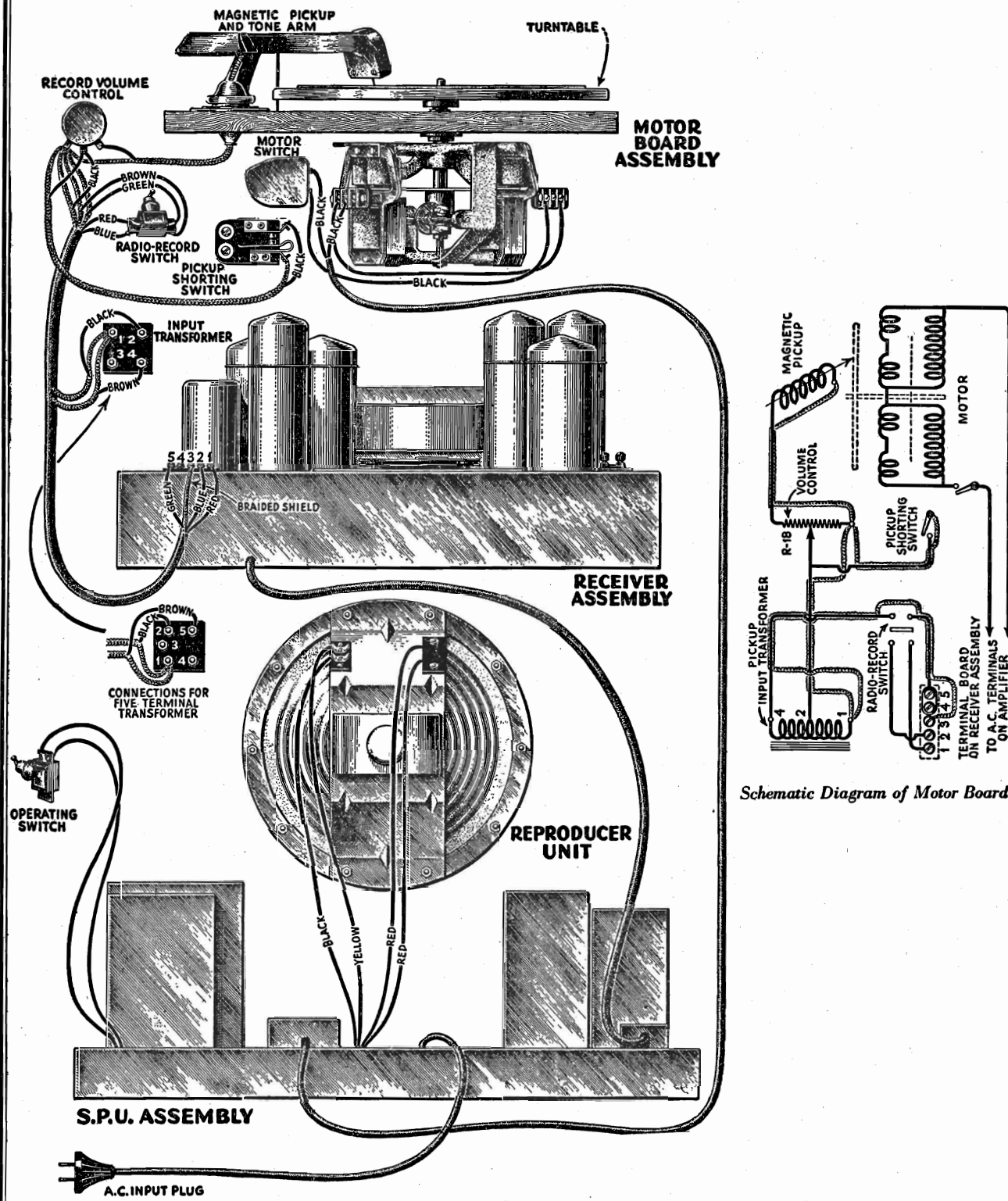

Schematic Diagram of Motor Board

MODEL RE-73
Parts List

R. C. A. VICTOR CO., INC.

REPLACEMENT PARTS

Stock No.	DESCRIPTION	List Price	Stock No.	DESCRIPTION	List Price
RECEIVER ASSEMBLY—Continued					
10838	Resistor—9000 ohms—Carbon type—Package of 5	\$2.50	3052	Screw assembly—Pickup pole piece mounting screw, nut, washer—Package of 10 sets	.50
10839	Resistor—130 ohms—Carbon type—Package of 5	2.50	3101	Switch—Record-radio toggle switch with mounting nuts and escutcheon plate—Located on top of motor board	1.25
10840	Resistor—2300 ohms—Carbon type—Package of 5	2.50	3102	Receptacle—Needle receptacle	.75
10841	Resistor—1½ megohm—Carbon type—Package of 5	2.50	3158	Screw assembly—Motor mounting screw assembly—Comprising 3 screws, 3 bushings, 3 metal washers and 12 cushion washers	.80
10842	Capacitor—10 mfd. condenser—Package of 2	.60	3162	Regulator—Speed regulator with mounting screws—Comprising cam and shaft, bushing and bracket	.80
10843	Shield—Radiotron shield body with cap—Package of 1 set	.90	3163	Escutcheon—Speed regulator escutcheon with mounting screw—Package of 5	2.00
10844	Shield—Coil shield body with cap—Package of 1 set	.90	3164	Control—Record volume control with mounting washer and nut—Less knob	1.70
10851	Panel—Radio chassis escutcheon panel—Less dial	3.00	3167	Magnet—Pickup magnet	2.60
10920	Cable—Wiring cable—Used to connect receiver to amplifier	2.75	3168	Coil—Pickup coil	.85
10948	Spring—Tuning condenser spring—Package of 5	.50	3169	Shoe—Pickup pole shoe R. H.	1.45
10949	Link—Tuning condenser link—Bakelite—Package of 5	.60	3170	Shoe—Pickup pole shoe L. H.	1.45
10969	Roller—Tuning condenser roller and shaft with eyelet screw and nut—Package of 5	.50	3249	Sleeve—Spindle sleeve complete with set screw	.50
S. P. U.					
2721	Socket—UX-245 Radiotron double socket with insulator and rivets	1.00	6067	Lever—Speed control regulator lever for motor—Comprising lever, spring, mounting bolt, nut and washer	1.60
2722	Resistor—55 ohm—Mid-tapped—Wire wound—Filament resistor	1.00	6069	Coil assembly—Located nearest governor—105-125 volts, 60 cycles—Comprising 2 current coils, 1 voltage coil, laminated core end bracket, terminal board, nuts, bolts, screws and washers—Completely assembled ready for mounting	8.40
2723	Switch—Operating switch—Toggle—With mounting nuts and washer—Package of 5	3.00	6070	Coil assembly—Located farthest from governor—105-125 volts, 60 cycles—Comprising 2 current coils, 1 voltage coil, laminated core, end bracket, terminal board, nut, bolts, screws and washers—Completely assembled ready for mounting	8.40
2757	Strip—Terminal strip—Two contact	.50	RECEIVER ASSEMBLY		
2880	Resistor—70,000 ohms—Carbon type—Package of 5	3.00	2012	Condenser—1200 MMFD. condenser	\$0.55
2963	Resistor—8,000 ohms—Carbon type—Package of 5	2.50	2546	Resistor—1 megohm—Carbon type resistor—Package of 5	3.00
7053	Resistor—715 ohms—Wire wound	.70	2746	Socket—Dial lamp socket	.50
7054	Cord—Amplifier power cord with male connector plug	1.00	2747	Cap—Contact cap—Package of 5	.50
7075	Socket—UX-280 Radiotron socket	1.80	2748	Posts—Twin binding posts with lock washers and nut—Antenna and ground	.50
7224	Cover—Fuse cover with bushing and insulator	.50	2804	Knob—Volume or station selector knob—Package of 5	2.50
10845	Transformer—A. F. transformer	14.00	2966	Resistor—28,000 ohm—Carbon type—Package of 5	2.50
10907	Fuse—3 amperes—Package of 5	1.00	2970	Resistor—½ megohm—Carbon type—Package of 5	2.50
10908	Cover—Terminal strip cover—Package of 2	.50	7124	Socket—UY Radiotron socket	.80
10909	Condenser—Condenser bank—60 cycles	16.00	7303	Dial—Station selector dial scale—Package of 5	3.00
10910	Capacitor—Extra filter capacitor for 25 cycles	5.00	10426	Screw—Cam wheel adjusting screw—Package of 20	.50
10911	Reactor—Filter reactor	4.50	10805	Shield—Round condenser shield	.75
10912	Strip—Terminal strip—8 contacts	.70	10806	Shield—Variable condenser shield	1.50
10913	Cable—Amplifier wiring cable	2.00	10807	Shield—White enamel lamp shield	.60
10915	Transformer—Power transformer—105-125 volts—25-40 cycles	16.00	10808	Indicator—Dial indicator—Package of 5	.50
10917	Transformer—Power transformer—105-125 volts—50-60 cycles	12.00	10809	Plate—Cover plate with screw—Package of 5	.50
PHONOGRAPH PARTS					
2614	Switch—Automatic brake contact switch	1.40	10810	Roller—Cam roller—Package of 5	.50
2615	Springs—Brake springs—Set of 4 springs—Package of 2 sets	.50	10811	Condenser—Variable condenser	3.50
2620	Cushions—Pickup rubber cushion—Comprising 1 damper and 2 pivot cushions—Package of 5 sets	1.25	10812	Shaft—Cam roller shaft with washer and nuts—Package of 2	.50
2622	Coil assembly—Located nearest governor—105-125 volts, 25 cycles—Comprising 2 current coils, 1 voltage coil, laminated core, end bracket, terminal board, nuts, bolts, screws and washers—Completely assembled ready for mounting	9.00	10813	Control—Tone control with plate washers and nut	1.60
2623	Coil assembly—Located farthest from governor—105-125 volts, 25 cycles—Comprising 2 current coils, 1 voltage coil, laminated core and bracket, terminal board nuts, bolts, screws and washers—Completely assembled ready for mounting	9.00	10814	Shield—Filter coil and capacitor shield with washers and nuts—Package of 2	.60
2691	Governor—Comprising shaft with worm, brake disc, weights, springs and screws—Assembled	5.25	10815	Coil—Filter coil and capacitor with mounting screws, lock washers and nuts	\$1.50
2692	Bearings—Governor shaft bearings—One set of 2	1.35	10816	Coil—3rd R. F. coil	1.60
2693	Gear—Governor drive worm gear with set screw	1.35	10817	Coil—Link coil	1.50
2695	Bearings—Threaded thrust bearing with lock nut for end of turntable spindle	.50	10818	Condenser—Bank of two condensers—0.25 and 0.75 mfd.	1.80
2759	Box—Needle box with lid—Package of 2	.60	10819	Condenser—Bank of three condensers—Three 0.1 mfd.	1.80
2765	Screw—Pickup needle holding screw—Package of 10	.80	10820	Condenser—100 mmfd. condenser	.50
2766	Screw—Pickup cover mounting screw—Package of 10	.50	10821	Coil—Resistor board coil	.80
2767	Spring—Pickup magnet spring—Package of 10	.50	10822	Wheel—Cam wheel with spring washers, cup washer and pin	2.60
2768	Armature—Pickup armature	.50	10824	Strip—Terminal strip with insulation and rivet—Two contact	.50
2770	Plate—Pickup damper plate—Package of 5	.50	10825	Inductor—Stabilizing inductor with screw, lock washer and nut	2.20
2771	Screw—Pickup damper plate mounting screw—Package of 10	.50	10826	Control—Volume control with nut, washer and locking plate	2.50
2787	Switch—Pickup shorting switch	1.00	10828	Coil—Antenna coupling coil	1.50
2789	Cord—Motor cord—Connects motor coil and starting switch	.60	10829	Coil—1st R. F. coil	1.60
2826	Cable—Shielded cable from shorting switch to record volume control	.50	10830	Coil—2nd R. F. coil	1.60
2829	Knob—Motor board lifting knob and screw—Package of 2	\$0.50	10831	Strip—Terminal strip with link	.70
2858	Rest—Pickup rubber rest with mounting bracket—Package of 5	.50	10832	Socket—UX Radiotron single socket with insulator	.60
			10833	Strip—Terminal strip with insulation and rivets—Six contacts	.70
			10834	Clip—Tube socket clips—Package of 10	.50
			10835	Capacitor—0.01 mfd.	.50
			10837	Capacitor—Bank of three 0.1 mfd. capacitors	.75

R. C. A. VICTOR CO., INC.

MODEL RE-73
Top Views

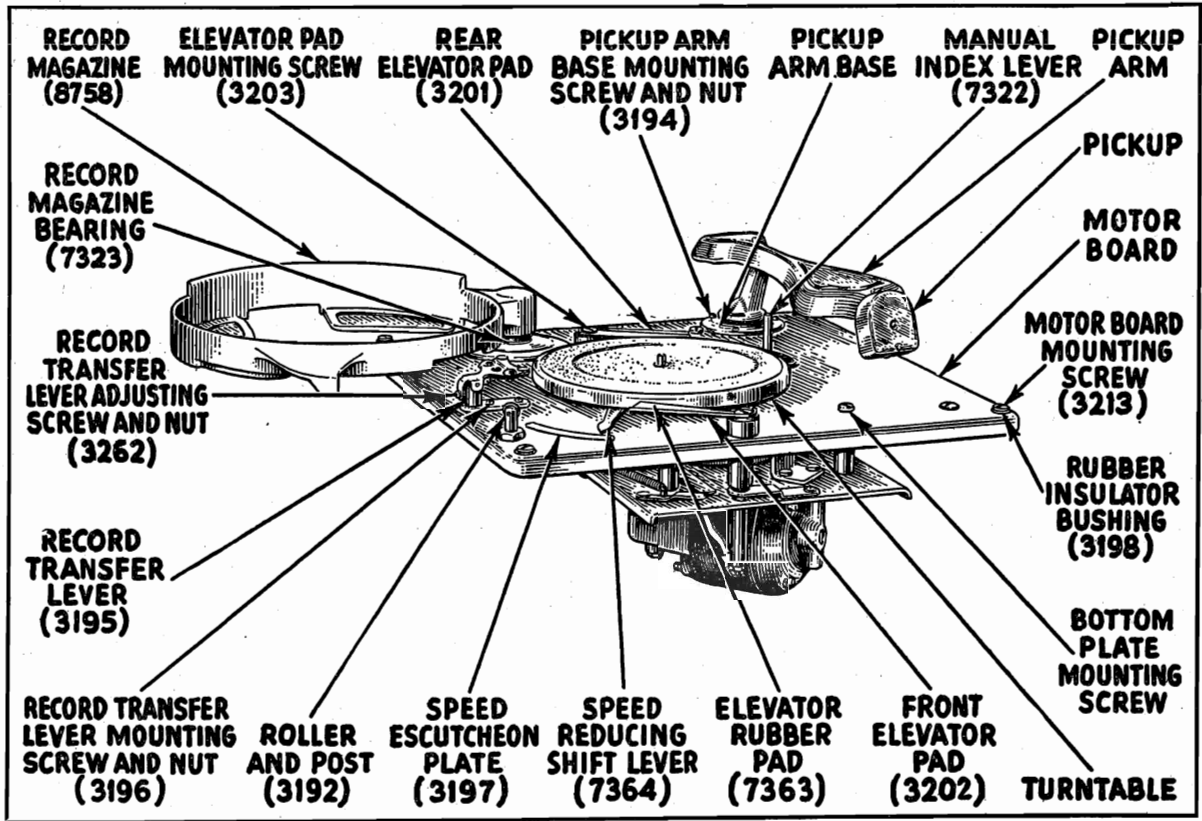

Top view of mechanism showing parts

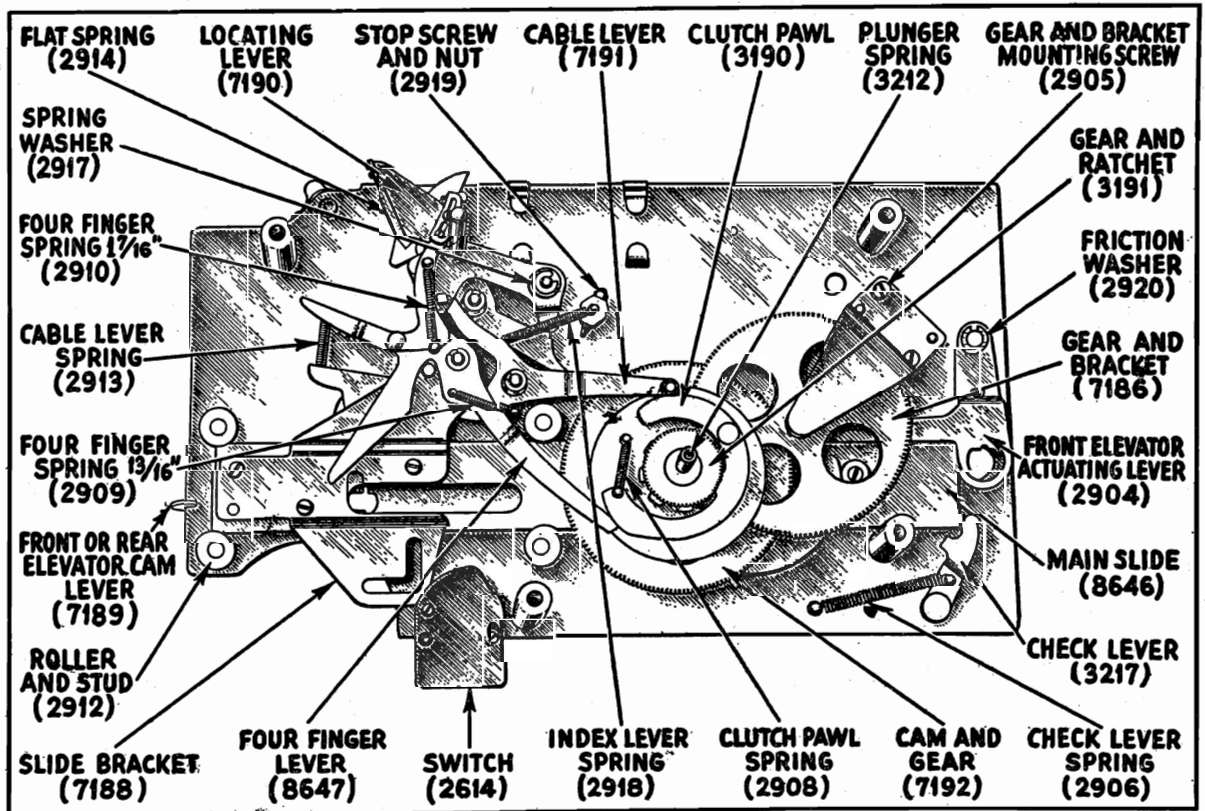

Top view of mechanism with plate removed

Re-aligning
Tuning Condensers

R. C. A. VICTOR CO., INC.

Under normal conditions, the occasion will seldom arise when it will be necessary to re-align the tuning condensers. Low sensitivity and selectivity and improper dial settings over certain sections of the dial for stations of known broadcast frequencies are indications that the tuning condensers are out of line.

NOTE: Improper dial settings should not be confused with improper location of selector scale.

The parts required for re-aligning consist of a modulated oscillator such as stock No.A-6004; a special aligning wrench, stock No.A-6085; and a 0-8 a-c. voltmeter.

The Victor oscillator is accurately calibrated at 550,710,1000,1300 and 1500 kilocycles. These aligning frequencies, which are the correct values used in the factory, must be employed in all cases. If a standard wavemeter is not available for calibrating, the signals from a number of reliable broadcast stations, operating on known frequencies from 550 to 1500 KC, can be used by plotting a curve of oscillator dial settings against frequencies.

Proceed to re-align the tuning condensers in the following manner:

- a. Disconnect the link (on straight radio models) across the two terminals on the base of the amplifier, and connect one side of the 0-8 volt a-c. voltmeter to the terminal nearer the UX-245 Radiotrons. Connect the other side of the a-c. voltmeter to No.3 terminal (ground) on the amplifier terminal strip or clip to any clean metallic part of the amplifier base. The meter is thus connected in the speaker output circuit, but the voice coil is out of the circuit. Silent aligning can thus be accomplished.
- b. Connect the shielded leads from the oscillator terminals to the antenna and ground terminals of the radio set, making sure that the ground wire is still connected to the radio chassis.
- c. Remove the small metal plate in the center of the cam wheel by taking out the retaining screw.
- d. Place the radio set in operation with the volume control turned to maximum.
- e. Place the oscillator in operation at 550 KC. and move the tuning lever of the Victor Radio until the oscillator signal is heard. Adjust the oscillator output volume control to obtain a reading of 2 or 3 volts on the a-c. voltmeter.
- f. It will be noted on the inside of the cam wheel that there are five groups of five screws each, and that the first screw of each group is opposite a cam roller. Using the special socket wrench No.A-6085, adjust each of the first screws until the reading on the a-c. voltmeter is a maximum. As the condensers are brought into alignment, it may be necessary to decrease the setting of the oscillator volume control in order to prevent the voltmeter from going off the scale.
- g. Move the tuning lever of the Victor Radio to 710 KC. and set the oscillator dial at this same frequency. Now adjust the second screw of each group until a maximum reading is obtained on the voltmeter.
- h. Repeat this procedure for 1000 KC., 1300 KC., and 1500 KC. The alignment is now complete. The flexible cam strip around the outer edge of the cam wheel assures perfect alignment between the aligning frequencies mentioned.
- i. Remove all oscillator and meter connections, and reconnect the link (or wire in the case of combination models).

R. C. A. VICTOR CO. INC.

SERVICE NOTES

for

RCA Victor Automatic Record
Changing Mechanism

The RCA Victor Automatic Record Changing Mechanism is used in RCA Victor Models RAE-26, RAE-59 and RAE-79. Except for the finish of exposed parts, these units are identical. This mechanism is of simple, fool-proof design and will perform efficiently with a minimum of service requirements. Features of this mechanism are; continuous playing of one side of ten 10-inch records, operation at either 33 1/2 or 78 R.P.M. for playing standard or Program Transcription records manually or automatically, a special clutch to prevent jamming in case of failure of a part and a heavy duty motor operating at synchronous speed thereby eliminating any need for regulating devices. A general view of the mechanism is shown on the cover page. Figure 1 shows the schematic wiring diagram.

The Replacement Parts for this mechanism are listed in the Service Notes on each individual instrument. The identification nomenclature given on pages 10 and 11, will be found useful in identifying parts. Where parts are identical in all models the Stock Number of each part is given in addition to its name.

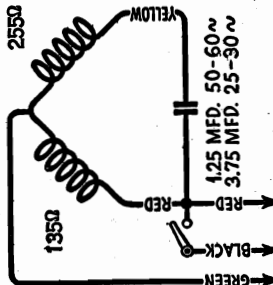

Figure 1—Schematic Diagram

INSTALLATION

After unpacking the instruments in which this mechanism is used, it is imperative that certain preliminary checks be made before they are placed in operation. These checks should be performed in the order given and any adjustments found necessary must be made.

1. When installing the instrument it is advisable to see that all parts are properly lubricated without excessive grease or oil on any parts. This is especially important in the speed reducing unit. A lack of oil in the spindle bearings or between the sprocket and the surface upon which it rests, may be the cause of a "wow" at slow speed. Also excessive grease on the gears or on the damper pads may cause this same condition. The motor should be lubricated with light oil once every six months. Oil holes are provided at each end of the motor. Once a year the turntable and speed reducing unit should be removed and all exposed gears thoroughly cleaned and lubricated with light grease. All bearings should be lubricated with oil. Be careful not to lose the spiral spring in the end of the spindle or the washers under the turntable and speed reducing unit.

2. The motor board must be level. This should be checked both ways by means of a small spirit level. Placing the cabinet legs on the same surface will usually insure the motor board being level.

3. A small spring is located in the center of the turntable spindle. Be sure that this is in position before placing the turntable on the spindle. After placing the turntable on the spindle make sure that the spindle nose may be easily depressed. If it is not, then remove the turntable and turn the spring upside down or replace it with a new spring.

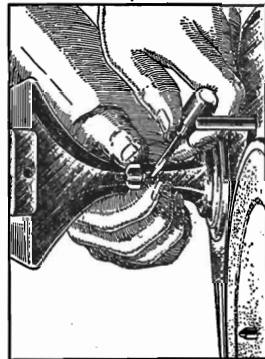

Figure 2—Adjusting height of tone arm

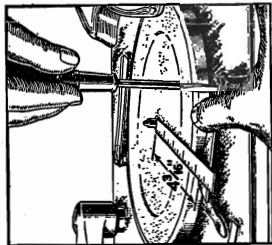

Figure 3—Adjusting elevator pad

4. Examine the wire cable that is attached to the back of the tone arm. It should be seated on the small pulleys over which it passes.
5. Place a Home Recording needle into the pickup as far as it will go. Then lower the pickup on the side of the turntable. The needle should extend from 1/8" to 1/4" below the top of the metal edge of the turntable. If it does not, an adjustment can be made by means of a screw located under the tone arm. Lifting the arm provides accessibility to the screw. See Figure 2.
6. If when starting the automatic mechanism, the needle lowers onto the smooth outer rim of the record but fails to swing into the first groove, it may be caused by the following:
 - (a) Cabinet not level. Check as indicated in Paragraph 1.
 - (b) Weak tension in spring. A flat spring presses against the tone arm lever on the under side of the motor board. See Figure 17 Page 11. Bending it so as to increase its tension against the tone arm lever will cause the needle to swing into the first record groove. Be careful not to bend it too much as excessive tension will cause the needle to skip several grooves.

7. After the instrument has completed one record changing operation, a ten inch record should extend about three-quarters way over each elevator pad. If this condition does not exist, an adjustment can be made by means of the screws that hold the pads in position. A pair of pliers heavily padded with cloth or other soft material should be used to hold the elevator shafts while loosening and tightening the screws. The distance from the closest part of either pad to the edge of the spindle is approximately 4 1/8". Figure 3 shows the method of making this adjustment.

If any adjustments are necessary other than the foregoing, a reference to the Service Date section of this booklet should be made.

Remember That the Control Lever Can Be Changed from Automatic to Manual Only When the Mechanism is Not Changing Records

MODEL RE-73
Notes Part 2
R. C. A. VICTOR CO., INC.
(3) FAILURE OF NEEDLE TO LOWER PROPERLY

Failure of the needle to lower onto the smooth outer rim of the 10-inch records when the instrument is playing automatically may be caused by:

- (a) Improper Tone Arm Setting. Loosen the set screws as shown in Figure 5. With the mechanism out of its cycle, press the locating lever at a point near the flat spring until the lever strikes the stop screw. Holding the locating lever, Figure 17, in this position, move the front portion of the trip lever, Figure 15, until the pin against which the flat spring presses, is making contact with the locating lever. Holding the two levers in this position, move the pickup arm until the needle is $\frac{1}{16}$ " from the first groove of a standard 10-inch record. Now retighten the two set screws shown in Figure 5.

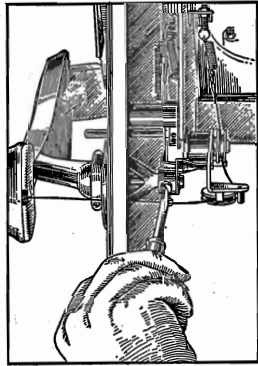

Figure 5—Adjusting position of lone arm

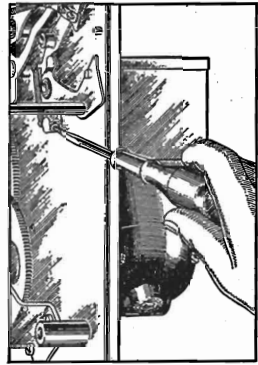

Figure 6—Adjusting lone arm locating screw

- (b) Improper adjustment of tone arm locating screw. This adjustment, shown in Figure 6, can be used to make a substitute adjustment for that described in (a), when the mechanism is out of the cabinet. Make the adjustment so that the needle will lower exactly $\frac{1}{16}$ " from the first groove on a standard 10-inch record. Loosen the lock nut on the adjusting screw by means of a No. 4 Spintite wrench on which the shoulder has been ground sufficiently thin for clearance. Do not attempt to make this adjustment without first loosening the lock nut. Tighten the lock nut when the proper adjustment has been made.

(4) FAILURE OF NEEDLE TO LOWER ONTO RECORD SURFACE

Failure of the needle to lower onto the record surface may be caused by:

- (a) Cable out of pulley. Examine the tone arm cable and ascertain that it is seated in the pulley.
- (b) Shielded pickup wire improperly placed. Examine the shielded lead coming out of the tone arm base and make sure that it is free from the moving parts of the mechanism.
- (c) Incorrect setting of tone arm lowering screw. Check the position of the tone arm as described in Paragraph 5, Page 4.
- (d) Turntable washer not in place. A leather washer is supplied to fit under the turntable. If this part is not in place, the turntable will be too low, and may cause the needle not to lower onto the record.
- (e) Incorrect adjustment of cable tension screw. The cable tension screw shown in Figure 7 should be so adjusted that the needle will lower smoothly onto the record without dropping. When this adjustment is obtained, the cable will be slightly loose when the needle is lowered onto a record. Loosen the lock nuts, turn the screw to the right or left as required and retighten the lock nut. Check the adjustment to make sure that the needle clears the record on the return of the tone arm. The needle should rise $\frac{1}{16}$ " from the record before any horizontal motion takes place.

(5) NEEDLE FAILS TO CLEAR RECORD AFTER PLAYING

Failure of the needle to clear the record surface on the return of the tone arm is caused by loose adjustment of the cable tension. Adjust this tension as described in Section 4, Para

SERVICE DATA

The following Service information will be found useful in making any adjustments or correction of any irregular operation that may be necessary. All the major adjustments are accessible from the rear of the cabinet. For the sake of clearness the illustrations in this text do not show the cabinet background.

No special tools are required other than a small offset screw driver. (Stock No. 2930) A stand consisting of three Stock No. 7203 will be found useful in supporting the mechanism should removal from the cabinet be required.

(1) SPEED VARIATIONS (WOW)

A variation in the speed of the turntable evidenced by distortion on long sustained notes when playing Program Transcription records may be caused by any of the following:

- (a) Improper operation. It is very important when changing the speed shift lever from 78 R.P.M. operation to 33 $\frac{1}{3}$ R.P.M. operation, to place the hand on the turntable and hold it until it is positively engaged by the driving mechanism.

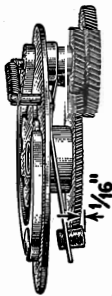

Figure 4—Adjustment of damper pads

- (b) Lack of proper lubrication. It is important that excessive grease on the gear reducing mechanism be avoided and that sufficient oil is present between the ratchet and the surface upon which it rests. Also clean and oil the spindle bearing and wipe off any excess lubricant that may be on the damper pads or the drive gear upon which it rests.
- (c) Improper Adjustment of the Damper Pads. The damping pads with the necessary springs are provided to place a load on the 33 $\frac{1}{3}$ R.P.M. driving gear at all times while it is in operation. Placing such a load on the gear takes up any possible play and reduces the possibility of a "wow" during operation at the slower speed. Adjust these pads by slipping each spring to one side and bend them until they are $\frac{1}{16}$ " beyond the opposite surface upon which they rest. (See Figure 4).
- (d) Washers Not in Place. A metal washer is placed directly under the speed reducing mechanism and a leather washer directly over it, both washers being over the spindle. These washers must be in their proper position. Also if the leather washer has become hard it must be replaced.
- (e) In some cases, removing the speed reducing mechanism and turning it approximately 90° and then replacing it, may eliminate a "wow" caused by improper meshing of the gears.

(2) ADJUSTMENT OF MAGAZINE ROLLER

The magazine roller should be set in such a position that the plane of the roller is 90° to a line drawn from the center of the magazine bearing to the center of the roller. The height should be adjusted so that it will just touch the magazine when it is empty.

R. C. A. VICTOR CO., INC.

MODEL RE-73
Notes Part 3

(6) FAILURE OF RECORD TO DEPOSIT ON TURNTABLE

Incorrect lowering of the record onto the turntable may be caused by:

- (a) Improper turntable spindle height. The height of the turntable spindle nose should be approximately $\frac{1}{32}$ above the inside bottom surface of the record magazine. Adjustment of this height made by means of the screw at the bottom of the motor. (See Figure 8).

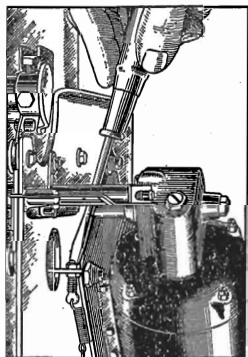

Figure 7—Adjusting lone arm cable tension screw

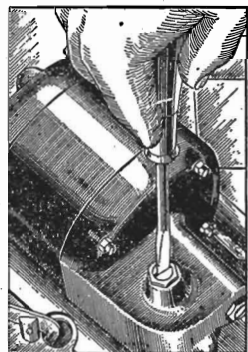

Figure 8—Adjusting spindle height

- (b) Improper setting of magazine. The horizontal swing of the magazine should be so adjusted when the mechanism is out of cycle that the outer surface at its nearest point to the nearest side of the turntable spindle is $5\frac{1}{32}$ ". This can be done by loosening the two screws as shown in Figure 9, moving the magazine to its correct position and retightening the screws.
- (c) Improper height of record transfer lever. The small plate on top of the motor board at the left side of the turntable should be so adjusted that it will depress approximately $\frac{1}{16}$ " when the magazine swings over the turntable. When this adjustment is made correctly, the transfer lever will engage the bottom record in the magazine as the latter is swinging back into the playing position. A small adjusting screw and lock nut are provided for this adjustment. See Figure 10.

- (d) Improper Position of Record Transfer Lever. When a ten-inch record is placed so that its edge touches both pins on the record transfer lever, a line drawn from the center of the hole of the lever to the center of the record hole should pass directly over the center of the spindle. See Figure 11. The two record transfer lever mounting screws can be loosened and the lever shifted until this condition exists. Also when a record is on the turntable it should just clear this lever. Unless this adjustment is properly made the record may not center properly over the spindle.

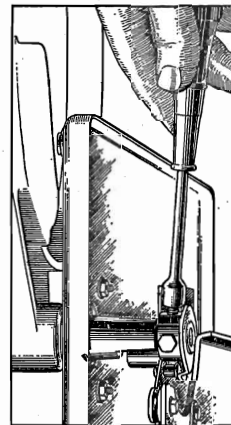

Figure 9—Magazine adjustments

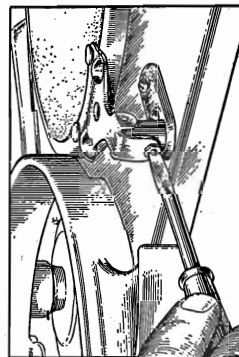

Figure 10—Record transfer lever adjustment

- (e) Weak spring in turntable spindle. The spring inside the turntable spindle which holds up the spindle nose will cause the records to align improperly with the turntable spindle if the spring tension is too weak or if the spindle nose is sticking inside the spindle. Access to the spring for stretching the coils or for replacement can be obtained by removing the turntable.

(7) RECORDS DISCHARGED IMPROPERLY FROM TURNTABLE

Failure of the Record on the turntable to be removed and placed in the magazine can be caused by:

- (a) Improper horizontal adjustment of elevator pads. The elevator pads Figure 16, should be so adjusted that the inside of the pad flange is $4\frac{3}{16}$ " from the nearest side of the turntable spindle. See Figure 3. Loosen the screw on top of the elevator shaft, move the pad to its correct position, holding both the pad and the elevator shaft in position and tighten the screw. Care should be observed that the ridge in the elevator shaft is not turned against the slot in the elevator shaft actuating lever so as to cut the latter. Grip the shaft with padded pliers while this adjustment is being made in order to prevent the shaft from turning. If for any reason the elevator pads have been removed, always place the one with the rubber surface toward the front of the mechanism when replacements are being made.
- (b) Improper adjustment of elevator shaft. The elevator shafts should rise to such a height as to give $\frac{1}{16}$ " clearance between the lowest surface of the elevator pad bottom and the top of the empty magazine. This adjustment can be made by means of the screw and the lock nut as shown in Figure 12.

(8) FAILURE TO TRIP ON ECCENTRIC GROOVE

Failure of the mechanism to change records when the eccentric groove is reached may be caused by:

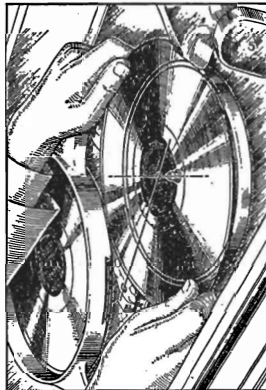

Figure 11—Method of checking transfer lever lateral adjustment

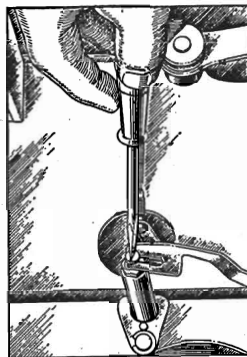

Figure 12—Adjusting height of elevator shaft

- (a) Improper setting of the latch plate. Adjust the latch plate, Figure 17, by means of a small offset screw driver such as Stock No. 2930, until it makes proper contact with the latch trip when the eccentric groove is reached.
- (b) Weak spring on trip lever. A weak spring on the latch trip lever will be a cause of failure to trip.

(9) INABILITY TO SET FOR MANUAL OPERATION

The manual operation lever should set in its back position so as to free the tone arm and prevent the mechanism from tripping. This change from automatic to manual operation should be made only when the mechanism is out of its cycle, otherwise the mechanism will reject continuously. The back position of the lever should be such that the end of the lever causes the latch trip to clear the latch plate by $\frac{1}{16}$ ". An incorrect setting of the latch plate may cause the trip lever to clear the plate at one position of the tone arm, but to make contact with the plate at some other position of the tone arm. Check this point when adjusting the latch plate.

(10) FAILURE TO STOP

Failure of the mechanism to stop after the "off" button has been pressed, and the mechanism has completed its cycle is caused by improper setting of the secondary stop switch. See Figure 17. The switch body should be so mounted that the contacts will open $\frac{1}{16}$ " when the cycle is completed, but will close as soon as the mechanism has tripped.

(11) CONTINUED TRIPPING OF MECHANISM

This condition may be caused by:

- (a) Manual operation lever set for non-automatic operation during cycle.
- (b) Improper setting of latch plate.
- (c) Improper timing of gears and associated parts. See Section 13 for the correct method of retiming.

(12) CLUTCH SLIPPING

Slipping of the clutch when the mechanism is passing through the cycle causing a loud clicking noise, may be caused by:

- (a) Weak spring on pawl carrier. Remove the pawl spring Figure 17, and increase its tension by removing two or three coils.

MODEL RE-73
Notes Part 4

R. C. A. VICTOR CO., INC.

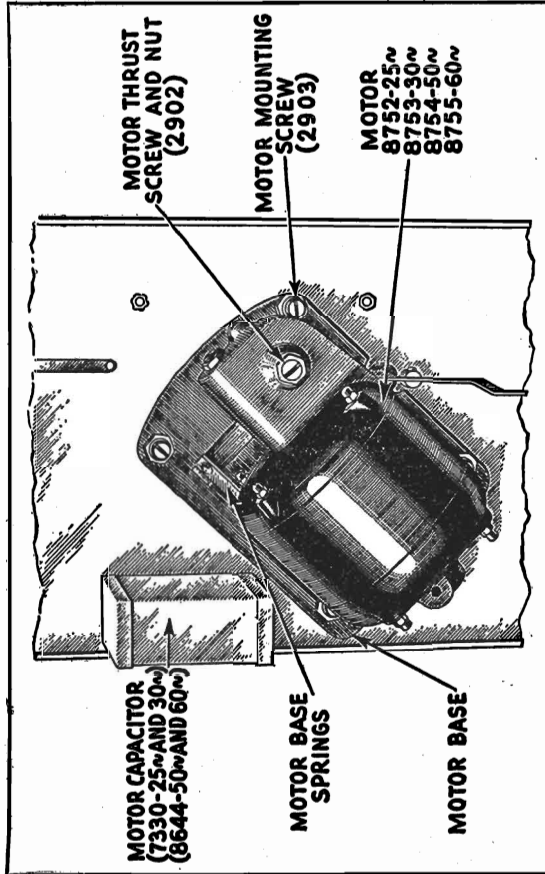

Figure 14—Motor parts

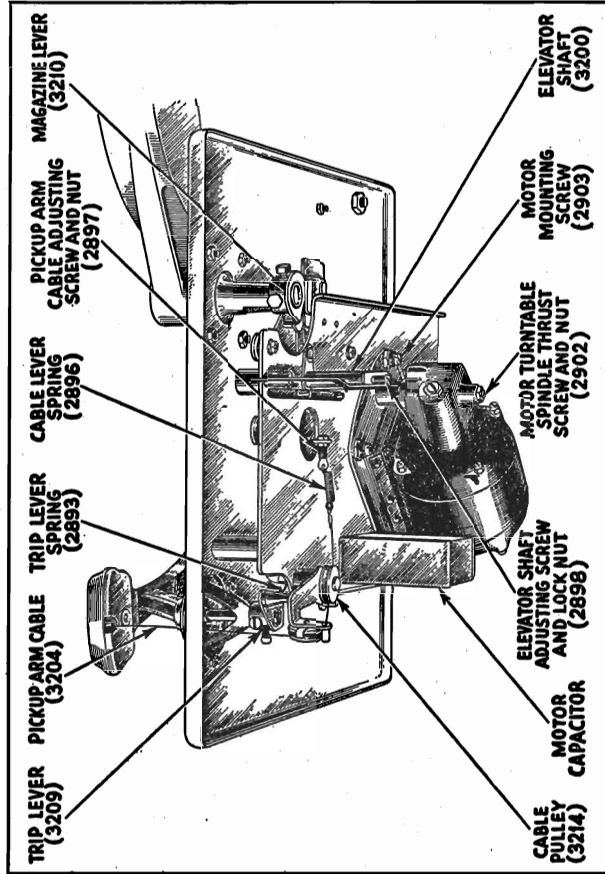

Figure 15—Bottom view of mechanism showing parts

- (b) Turntable spindle shaft too low. This condition will cause binding between the pawl carrier and the clutch wheel. Raise the spindle as shown in Figure 8.
- (c) Binding in any of the moving parts. Such binding may be in the slide, the magazine, the elevator shaft or the gears. The slide rollers at the left are mounted on eccentric shafts for adjustment of play. These may be so regulated as to cause excessive binding of the slide. Examine all of these parts carefully, and take any necessary steps to relieve the binding.

(13) RETIMING THE MECHANISM

Should it be necessary to retime the mechanism after replacing parts, or because of continued tripping proceed in the following manner:

- (a) Allow the mechanism to operate until the slide Figure 17 is in its extreme forwarding position. When this setting is reached the straight side of the cam, Figure 17, will be parallel with the side of the slide. Check the position of the trip lever and roller at this time to see that they are approximately as shown in Figure 13. If the various parts are not in their proper relation, the mechanism should be retimed.

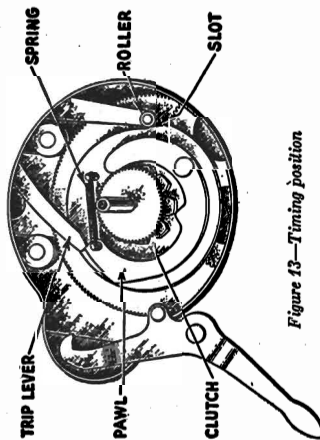

Figure 13—Timing position

- (b) Loosen the set screw in the clutch wheel and lift the wheel from the turntable spindle.
- (c) Lift the pawl carrier until it disengages from the gear.
- (d) Lower the pawl carrier into mesh with the gears so that the trip lever is touching the end of the pawl as shown in Figure 13, when the cable lever roller is engaged in the slot on the side of the pawl carrier as shown.
- (e) Recheck to see that the straight side of the cam is parallel with the slide.
- (f) Replace the clutch wheel and retighten the set screw, making sure that the set screw fits into the spot on the turntable spindle.

(14) REMOVING MOTOR BOARD

Should it be necessary to remove the motor board from the mechanism for replacement of any of the parts, the following procedure should be used:

- (a) Remove nuts and washers from the bolts which hold the motor board to the cabinet, and disconnect the pickup leads and power wiring to the mechanism. Then lift the mechanism from the cabinet.
- (b) Loosen the two set screws and remove the magazine lever Figure 9.
- (c) Lift out magazine.
- (d) Unhook tone arm cable from spring.
- (e) Loosen the two set screws in the tone arm lever.
- (f) Remove the three small screws in the tone arm base, taking care not to lose the lock nuts.
- (g) Disengage the tone arm lever from the tone arm shaft and carefully lift the tone arm from the motor board, bringing the tone arm lever and the shielded cable up through the tone arm base hole in the motor board.
- (h) Remove the screw and lock nuts in the bottom of the elevator shaft.
- (i) Lift elevator shaft from mechanism.
- (j) Unfasten wires from motor board.
- (k) Remove the four motor board screws which support the bottom plate.
- (l) Carefully lift the motor board from the mechanism.

Access can now be had to all the parts on the bottom plate. The parts can be assembled in the reverse order from that given above. It will then be necessary to make various adjustments after the parts have been reassembled.

R. C. A. VICTOR CO., INC.

MODEL RAE-79 Schematic

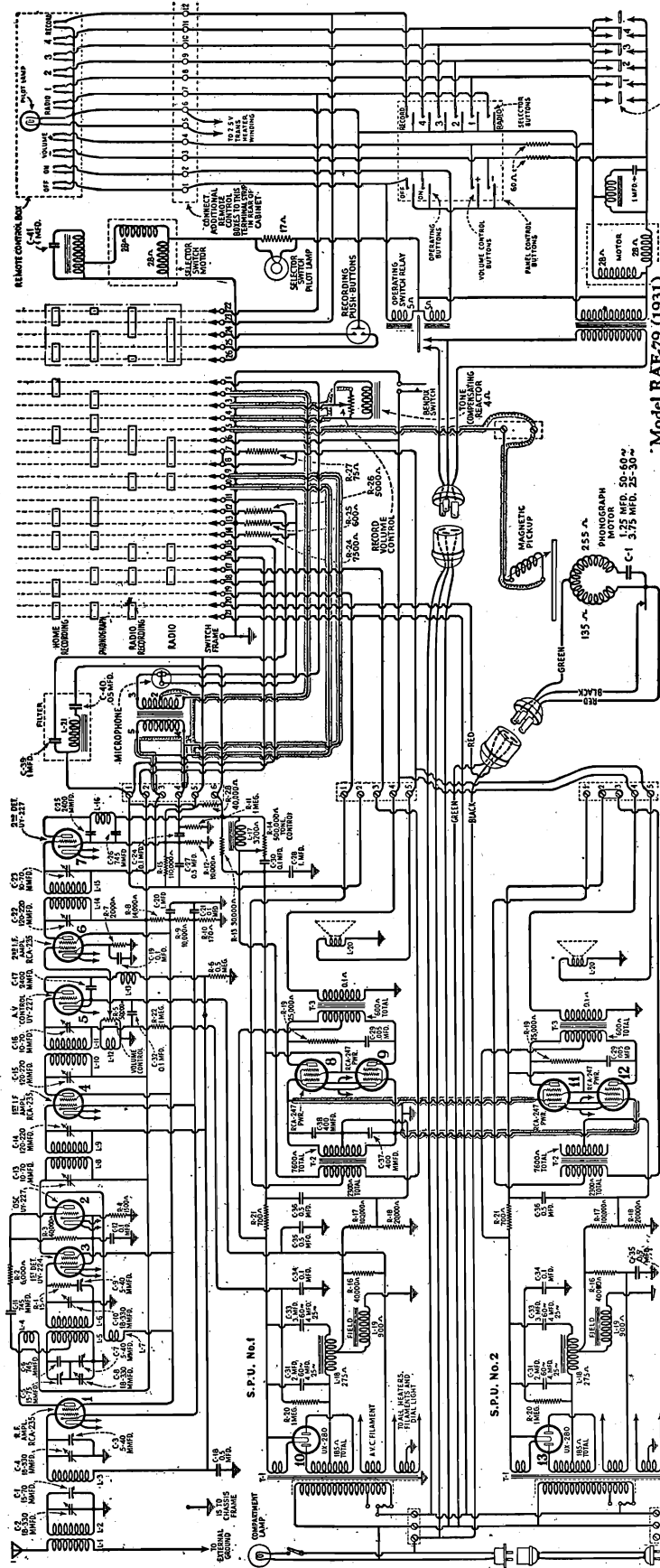

Model RAE-79 (1931)

2 DET IF A.V.C. IF 1 DET OSC RF
 '27 '35 '27 '35 '24A '27 '35

PILOT NO. 41 MAZDA
 AF '47 '47 RECT '80

RECTIFIER, AMPLIFIER NO. 1
 PILOT 115 V. TUBULAR INT. BASE
 AF '47 '47 RECT '80

RECTIFIER, AMPLIFIER NO. 2
 RECT '80

FRONT

Schematic diagram of Model RAE-79

PEAK FREQUENCY 175 KC

The RCA Victor Model RAE-79 is a thirteen tube, super-heterodyne radio receiver incorporated in the same cabinet with the perfected RCA Victor automatic record changing mechanism. Features of this instrument are:

RCA Victor DeLuxe Radio Chassis incorporating Super Control Radiotrons, automatic volume control giving a new degree of quiet operation, remote control of tuning and volume, double push-pull amplifiers employing Pentode Output Radiotrons, and twin loudspeakers. The automatic record changing mechanism has provision for playing continuously, one side of ten 10-inch records of either the "standard" or Program Transcription variety and either type twelve inch records manually. Home recording on the RAE-79 reaches a new degree of perfection through the use of a studio type two button microphone and Pentode Output Radiotrons. Such records may be made either 78 or 33 1/3 R.P.M. thus giving a maximum of eight minutes of home recording on a ten inch record.

A reference to the R-50 and R-55 Service Notes covers the general service data on this type of instrument.

**MODEL RAE-79
Remote Control**

R. C. A. VICTOR CO., INC.

Electrical Description of Unit

The remote control feature consists of a standard R-50 chassis with a special gang condenser; a capacitor motor coupled to the gang condenser through a series of gears; a series of drums and contactors by which the motor is started in the right direction for a given station and stopped at the right point; a special volume control geared to the motor; a relay to turn the set "on" or "off" and a remote control box by which these operations are controlled.

The motor is provided with a tapped reactor and condenser for changing the phase angle of the applied current so that operation in either direction may be secured. The motor operates at 23 volts for the station selector and 18 volts for the volume control.

Referring to Figure 1 we see the normal position of the motor armature. It will be noted that a spring holds the armature so that the gear at one end is meshed with the volume control gears. At 18 volts, the voltage used for volume control operation, the gears remain in this position and operation of the volume control is secured. When the speed of the motor is increased by operating it at 23 volts, this voltage being used when the selector buttons are pressed, the end thrust of the armature causes it to move laterally, thereby disengaging the gear at the volume control end and engaging the gear at the station selector end. See Figure 2. The spring at the end of the armature causes it to always return to the volume control position when the current is "off" at the motor. As this action takes place with the motor operating in either direction, controlling the voltage at which the motor is operated determines its function. A sixty ohm resistor is placed in each motor circuit controlling the volume to reduce the voltage from 23 to 18 volts.

The proper direction of operation and stopping of the motor for selection of a desired station is controlled by a series of drums and contactors. Figure 3 shows a schematic circuit of the motor and its adjacent circuits. The drums hold the contactors in the proper position so that when a particular selector button is depressed, the motor will turn in the right direction. When the contactor is at the point on the drum where it is half way between each contact, the motor stops. This is 180° from the hole that is used to set the drum for a particular station.

The setting of the drums is made by the pins on the front panel. These are known as the "setting buttons." The selector button is pressed and the drum is moved by the motor until the corresponding contactor is midway between the contacts. The pin will now fall in the hole in the drum if pushed in by the finger. See Figure 4. Holding the pin firmly in the hole, the desired station is then accurately tuned in by means of the manual station selector knob. After tuning the pin is then released. As the point on the opposite side of the drum is where the diameter of the drum changes, the contactor is half way between the contacts. Pressing the selector buttons will therefore cause no movement of the motor. If another button is pressed and the drum moved, pressing the original button will always bring the drum back to the position for which it was set.

Referring to Figure 10, the schematic diagram, it will be noted that a common lead is used for the pilot lamp and the selector buttons in the remote control box. By doing this, when a selector button on the box is pressed, the current through the common lead is increased, likewise the voltage drop in the lead is increased. The result is that while the motor is running the pilot lamp becomes very dim. As soon as the motor stops, the lamp flashes bright, thus indicating that the motor has stopped and the station is tuned in. If the station is not then heard, it is necessary to press the + volume control button a little at a time until the desired output level is obtained.

Special Installations

(1) INCREASING LENGTH OF REMOTE CONTROL BOX CABLE

The cable to the remote control box supplied with the remote control models is twenty-five (25) feet in length. This is ample for most rooms as it is very rare that a person wishes to listen to a program at a greater distance from the loudspeaker.

If, however, it is desired to place the remote control box at a greater distance from the set, any twelve conductor cable, the wires of which are No. 14 or larger in size, may be used to splice onto the regular cable and increase the total length up to seventy-five (75) feet. Figure 5 shows the method recommended for adding this additional cable.

(2) INCREASING NUMBER OF REMOTE CONTROL BOXES

One remote control box is supplied as standard equipment. Any number of additional boxes may be installed if desired although only one box can be used at a time for controlling the receiver. The boxes should be connected in parallel at the terminal strip on the rear of the Radiola. Figure 11 shows such a connection.

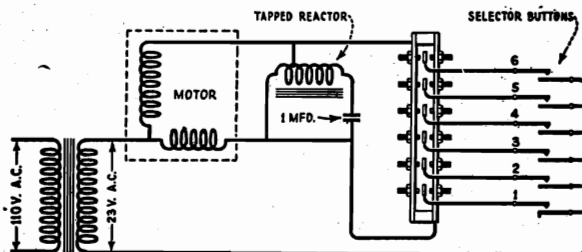

Figure 3—Schematic diagram of motor circuits

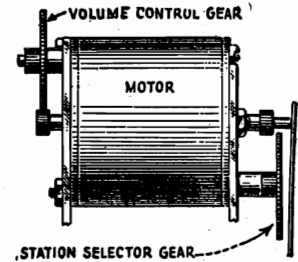

Figure 1—Motor with armature in volume control position

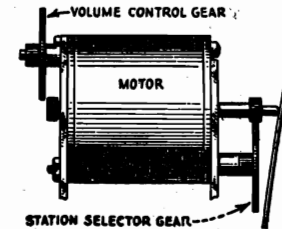

Figure 2—Motor with armature in station selector position

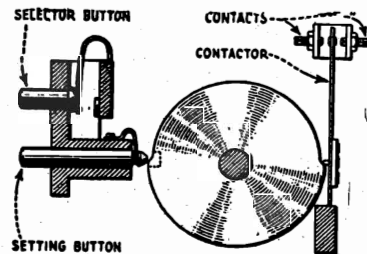

Figure 4—End view of drum and contactor

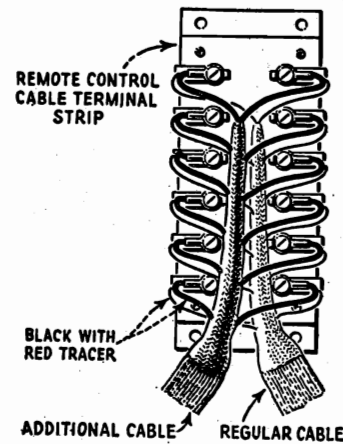

Figure 6—Connections for adding additional boxes

**MODEL RAE-79
Motor Adjustment**

R. C. A. VICTOR CO., INC.

Adjustments

(1) ADJUSTMENT OF MOTOR CONTACTORS

The four station selector motor contactors located at the rear of the motor may require adjustment due to changes in the amount of friction in the entire drive assembly. Need for adjustment is evidenced by the motor failing to stop at the exact point for a particular station.

In order to make these adjustments two tools are necessary. They may be constructed, see Figure 7, or obtained as a spare part, the replacement parts section listing them. The chart on page * gives the procedure to be followed for making adjustments. This procedure must be repeated on each contactor that is out of adjustment.

If all contactors are out of adjustment in a similar manner, then the friction screw, see Figure 8, requires adjustment. This should be either tightened or loosened, the exact adjustment to be determined by trial. The adjustment that is correct for one contactor will be correct for all, assuming the friction screw to be at fault.

(2) REPLACING OR ADJUSTING CONTACTORS

Six contactors are used for connecting the motor so that it rotates in the proper direction. To make this adjustment or replacement, a special offset screw driver will be required unless the unit is to be removed from the base. This is shown in Figure 12

Referring to Figure 4 we see that when the setting button is in the hole in the drum, the contactor for that particular drum is exactly half way between the contacts. The holes that hold the contactors are elongated so that they may be raised or lowered until they rest exactly half way between the contacts when the setting button is inserted in the drum hole. This is the only adjustment required of these contactors, and with the special screw driver is quite easy to make.

(3) MAKING REPLACEMENTS

The operating relay, the resistors, the motor, the gears and other small parts may be replaced. All power transformers when replaced must have the primaries so connected that the pilot light on the remote control box lights properly. If the transformers are improperly phased, the lamp will brighten instead of dim when a selector button is pressed. The drum assembly is specially fitted and assembled and any individual replacements can not be made. If trouble is experienced in this assembly, a complete replacement of the unit will be required.

SELECTOR SWITCH AND MISCELLANEOUS INFORMATION

(1) BENDIX LOUDSPEAKER SWITCH

At the end of the selector switch motor a switch is located that shorts the cone coil when the instrument is changing from one function to another.

The switch is operated by the lateral thrust of the motor wherever it goes into operation. If for any reason, noise should be heard when changing from Radio to Record or Home Recording, it may be due to this switch not functioning. Bending the lever so that it makes proper contact will remedy this condition.

(2) PRECAUTIONS WHEN MAKING RADIO RECORDING RECORDS

When making radio recording records, it is necessary that the radio volume be adjusted for its greatest undistorted output if good quality records are to be obtained. While using the maximum undistorted output it is also important that the volume control should not be advanced beyond this point, as it is possible that the maximum *distorted* output, if fed into the pickup long enough, will cause the pickup coil to heat and its wax to run out.

(3) SERVICE DATA ON MICROPHONE

The Microphone used on Model RAE-79 is a two-button studio type that has excellent frequency characteristics and is simple and rugged in construction. Generally, any failure in the microphone can be remedied only by replacing the unit. However, an unbalance in the buttons may be corrected by means of a small adjustment. The following procedure details the correct manner in making this adjustment. Refer to Figure 9.

(a) Remove the microphone from its shell. Be careful not to lose its supporting springs. Measure the D. C. resistance of each button. This may vary from 200 to 1000 ohms, but each button should be measured within 50% of the other.

(b) Loosen the set screw shown in Figure 9, and adjust the pressure of the cup by either increasing or decreasing its pressure against the diaphragm. Increasing the pressure reduces the resistance and decreasing it, increases the resistance of the button. Usually it is best practice to match the buttons by increasing the resistance rather than by decreasing it. Be very careful however to avoid spilling any carbon granules.

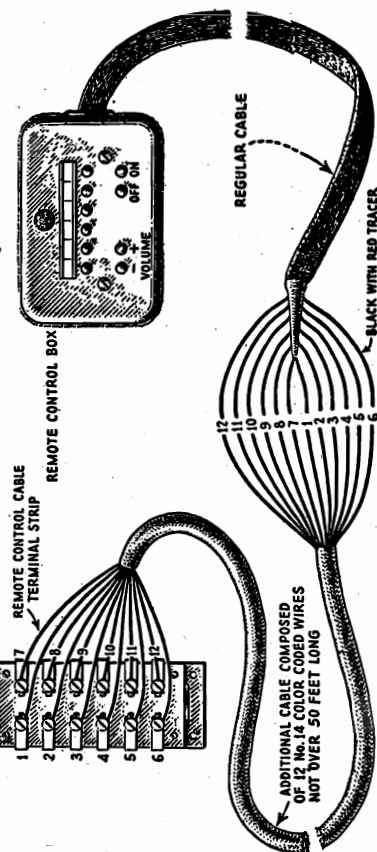

Figure 5
Wiring diagram of method for connecting additional cable

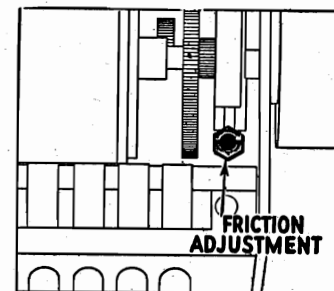

Figure 8—Location of Friction Adjustment

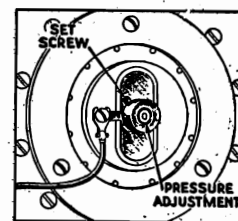

Figure 9—Details of Microphone Adjustment

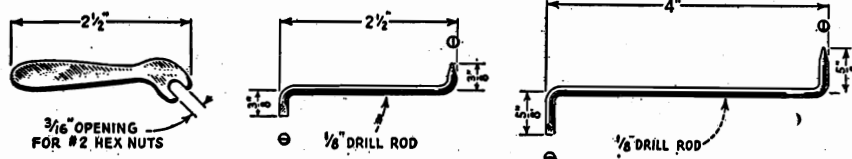
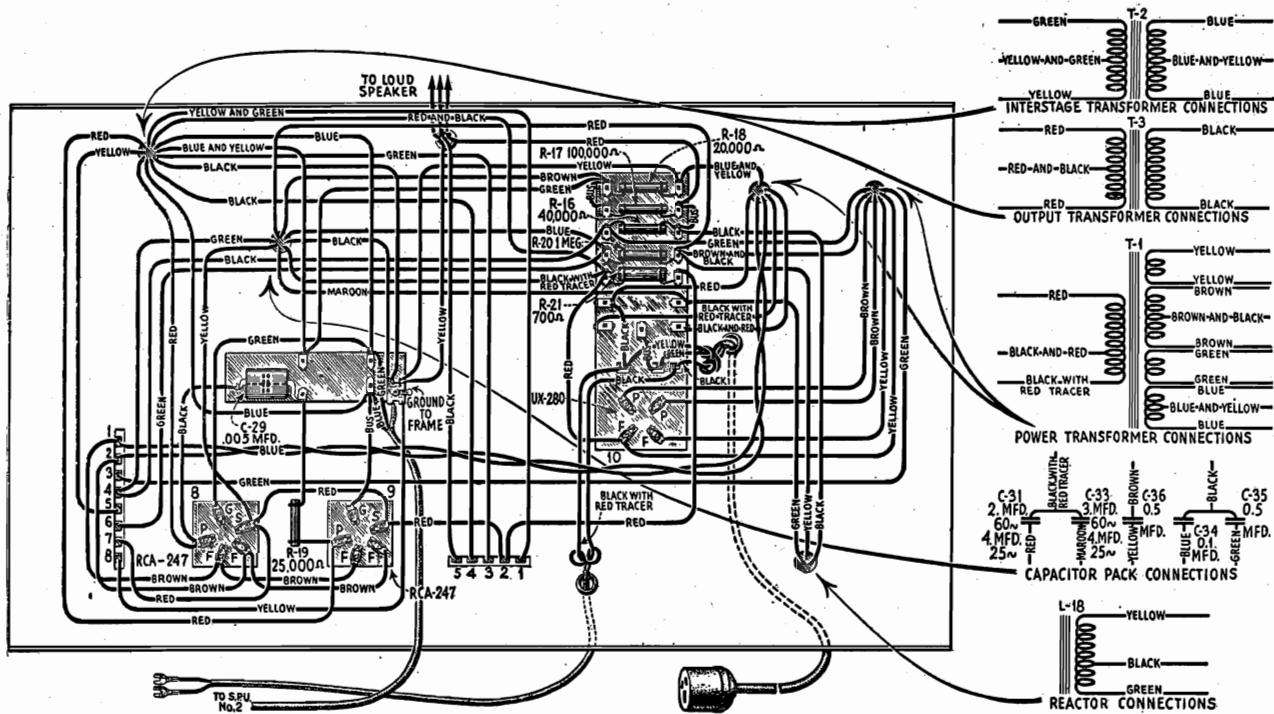

Figure 7—Constructional details of special tools used with remote control models

MODEL RAE-79
SPU-1, SPU-2
Chassis

R. C. A. VICTOR CO., INC.



S. P. U. No. 1 wiring

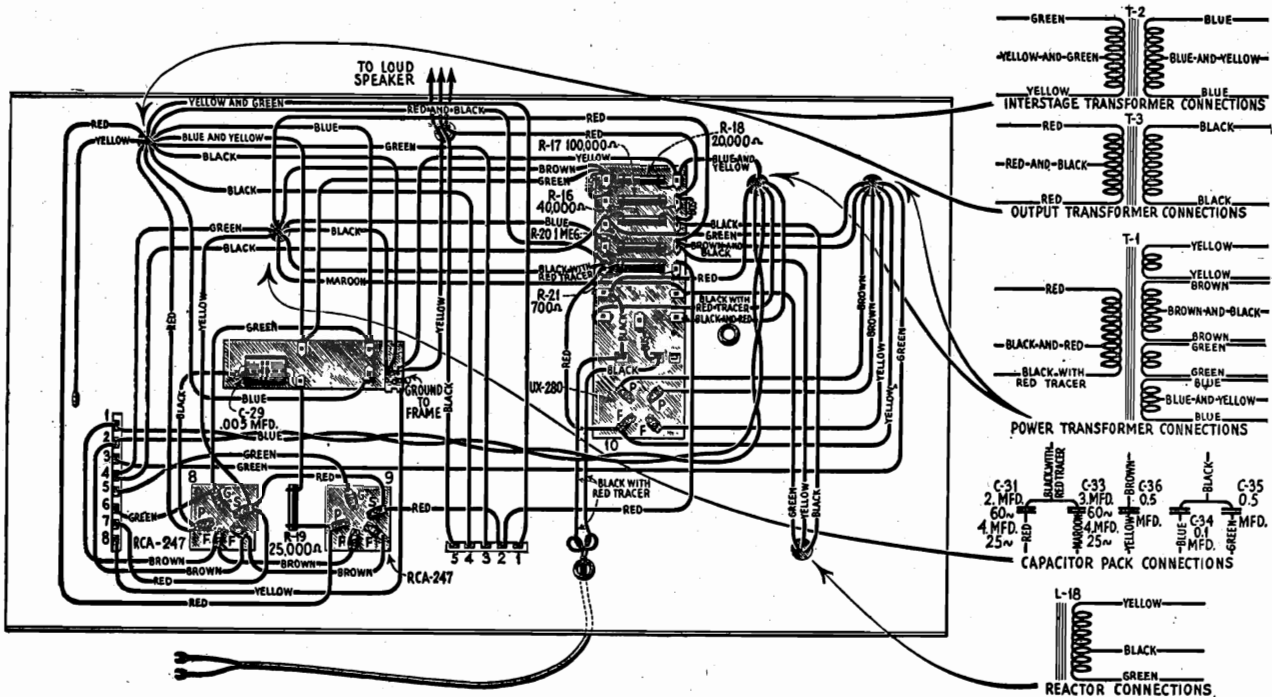

S. P. U. No. 2 wiring

MODEL Radiola 80
Resistance Data

R. C. A. VICTOR CO., INC.

All tubes out of sockets and AC plug disconnected from power supply.
Volume Control set for maximum signal unless otherwise specified

From Chassis To	Correct		Incorrect
Aerial to Ground	40	ohms	
Chassis to			
Link circuit condenser stator	5	ohms	TC-Y
RF Control Grid	5	ohms	TC- rf Cg-Y
RF Cathode (V.C.Min)	2,570	ohms	BC- rf K-Y (.1 mfd) BC- rf Sg-Y (.5 mfd)
RF Cathode (V.C. Max)	170	ohms	See V.C. Min
RF Screen Grid	16,000	ohms	BC- rf Sg- Y (.5 mfd) BC-2 D - Y (1. mfd) FC- '80 F-Y (3. mfd) See RF Cathode
RF Plate	26,597	ohms	
RF Plate to '80 Fil	42	ohms	
1 Detector Control Grid	5	ohms	TC- 1 D Cg-Y
1 Detector Cathode	2,000	ohms	BC- 1 D K-Y (.1 mfd)
1 Detector Screen Grid	16,000	ohms	See RF Screen
1 Detector Plate (distant)	26,594	ohms	See RF Screen
1 Detector Plate to '80 Fil9 distant)	39	ohms	
Oscillator Control Grid	42,000	ohms	BC- 1 D K-Y (.1 mfd) Oscillator Grid condenser)
Oscillator Cathode	2,000	ohms	BC- 1 D K-Y (.1 mfd)
Osc control grid to cathode	40,000	ohms	
Oscillator Plate	16,000	ohms	See RF Screen
Oscillator Plate to RF Screen	1	ohm	
1 IF Control Grid	41	ohms	TC- 1 IF Cg-Y
1 IF Control Grid to distant switch	541	ohms	"Distant" Adjustment
1 IF Cathode	170	ohms	See RF Cathode
1 IF Screen Grid	16,000	ohms	See Rf Screen
1 IF Plate	26,594	ohms	See RF Screen
1 IF Plate to '80 Fil	39	ohms	
2 IF Control Grid	41	ohms	TC- 2 IF Cg-Y
2 IF Cathode	2,000	ohms	BC- 2 IF K-Y (.1 mfd)
2 IF Screen Grid	16,000	ohms	See RF Screen
2 IF Plate	26,594	ohms	See RF Screen
2 Detector Control Grid	41	ohms	TC-2D Cg-Y
2 Detector Cathode	9,346	ohms	BC-2D K-Y (1. mfd)
2 Detector Plate	28,540	ohms	FC-'80 F-Y (3 mfd)
2 Det Plate to '80 Fil	1,985	ohms	BC-2DP-2DK(.0024 mfd)
'45 Control Grid	66,500	ohms	
'45 Control Grid to Control Grid	13,000	ohms	
'45 Plate	26,730	ohms	See RF Screen
'45 Plate to 45 Plate	350	ohms	
'45 Plate to '80 Fil	175	ohms	
'45 Filament	730	ohms	BC-715 ohm unit-Y (.05 mfd)
'80 Filament	26,555	ohms	
'80 Filament to '80 Plate	28,445	ohms	FC-80F (2 mfd) FC-80F (3 .mfd) Harm. Condenser (3. mfd) See RF Screen
80 Anode to 80 Anode	350	ohms	
Speaker field only	1,330	ohms	
Output transformer secondary only	.8	ohm	
Voice coil only	10	ohms	
Oscillator coil only	5	ohms	
Across AC Plug	3.5	ohms	

R. C. A. VICTOR CO., INC.

MODEL Radiola 82
Power Unit Chassis

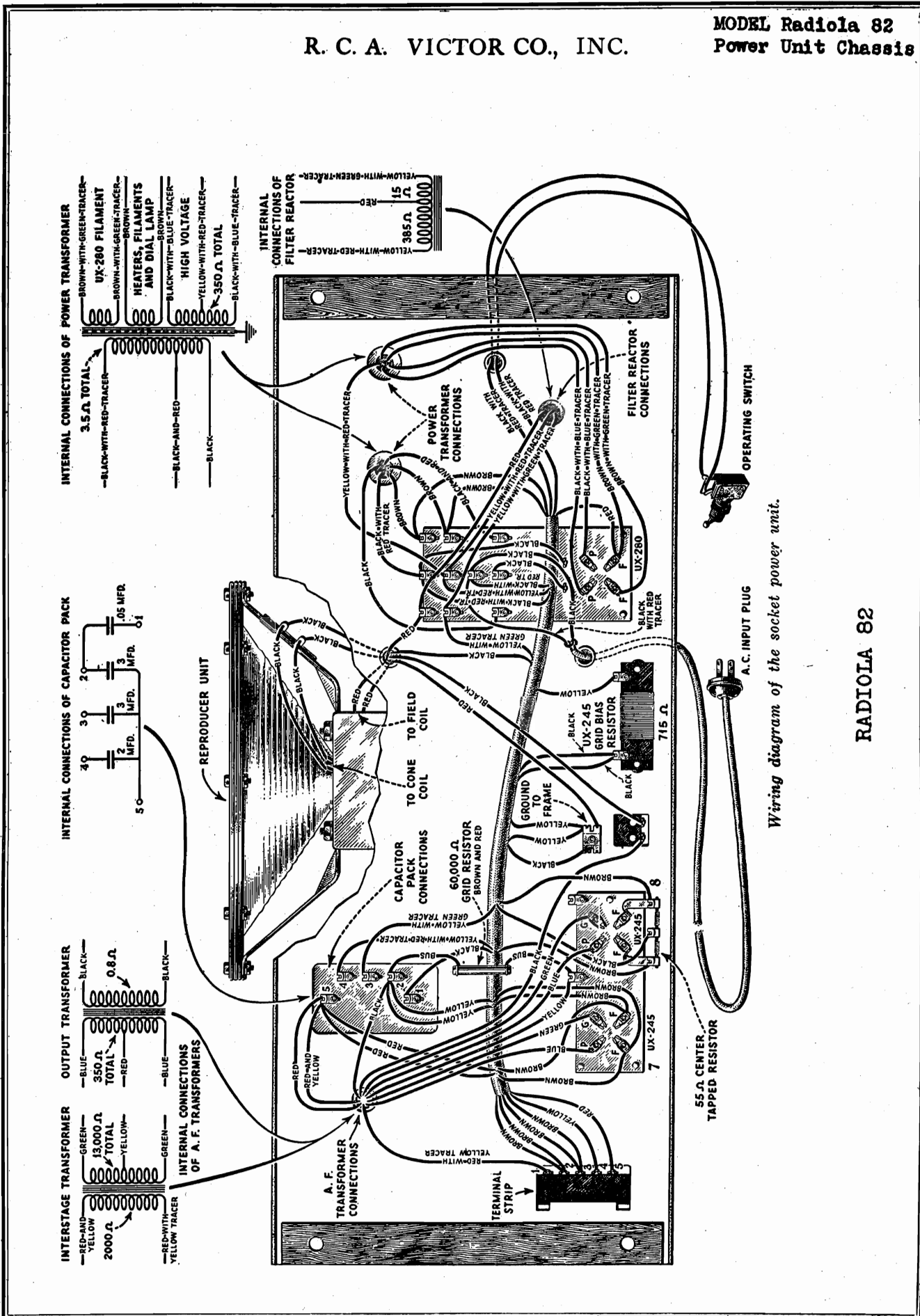

Wiring diagram of the socket power unit.

RADIOLA 82

MODEL Radiola 82
Resistance Data

R. C. A. VICTOR CO., INC.

66,500 ohms
 13,000 ohms
 26,730 ohms
 350 ohms
 175 ohms
 730 ohms
 26,655 ohms

See RF Screen
 See RF Screen
 BC-715 Ohm Unit-Y
 Incorrect
 FC-80 F (2 mfd)
 FC-80 F (3. mfd)
 Har. condenser (3. mfd)
 See RF Screen

350 ohms
 1,330 ohms
 .8 ohm
 10 ohms
 5 ohms
 3.5 ohms

28,445 ohms
 350 ohms
 1,330 ohms
 .8 ohm
 10 ohms
 5 ohms
 3.5 ohms

45 Control Grid
 45 Control Grid to Control Grid
 45 Plate
 45 Plate to 45 Plate
 45 Plate to 80 Fil
 45 Filament
 80 Filament

From Chassis To
 80 Fil to 80 Plate
 80 Anode to 80 Anode
 Speaker Field only
 Output Transformer Secondary Only
 Voice Coil only
 Oscillator coil only
 Across AC Plug

40 ohms
 5 ohms
 5 ohms
 2,570 ohms
 170 ohms
 16,000 ohms
 26,597 ohms
 42 ohms
 5 ohms
 2,000 ohms
 16,000 ohms
 26,594 ohms
 39 ohms
 42,000 ohms
 2,000 ohms
 40,000 ohms
 16,000 ohms
 1 ohm
 41 ohms
 170 ohms
 16,000 ohms
 39 ohms
 41 ohms
 2,000 ohms
 16,000 ohms
 26,594 ohms
 9,346 ohms
 28,635-29,894 ohms*
 2,080-3,339 ohms*

TC-Y
 TC- rf Cg-Y
 BC- rf K-Y (.1 mfd)
 BC- rf Sg-Y (.5 mfd)
 See V.C. Min
 BC- rf Sg-Y (.5 mfd)
 BC- 2 D K-Y (1. mfd)
 FC- 80 F-Y (3. mfd)
 See RF Cathode
 TC- 1 D Cg
 BC- 1 D K-Y (.1 mfd)
 See RF Screen
 See RF Screen
 BC- 1 D K-Y (.1 mfd)
 Oscillator grid cond
 BC- 1 D K-Y (.1 mfd)
 See RF Screen
 TC- 1 IF Cg-Y
 See RF Cathode
 See RF Screen
 TC- 2 IF Cg-Y
 BC- 2 IF K-Y (.1 mfd)
 See RF Screen
 See RF Screen
 TC-2 D Cg-Y
 BC-2 D K-Y (1. mfd)
 *Depending upon tone setting
 Tone control condenser
 FC-80 F-Y (3. mfd)
 *Depending upon tone setting

From Chassis To
 Aerial to Ground
 Chassis to
 Link Circuit condenser stator
 RF Control Grid
 RF Cathode (V.C.Min)
 RF Cathode (V.C.Max)
 RF Screen Grid
 RF Plate
 RF Plate to 80 Fil
 1 Det. Control Grid
 1 Det. Cathode
 1 Det. Screen Grid
 1 Det. Plate (distant adj)
 1 Det Plate to 80 Fil (distant)
 Oscillator Control Grid
 Oscillator Cathode
 Oso. Cg to Cathode
 Oscillator Plate
 Oso Plate to RF Screen
 1 IF Control Grid
 1 IF Cathode
 1 IF Screen Grid
 1 IF Plate to 80 Fil
 2 IF Control Grid
 2 IF Cathode
 2 IF Screen Grid
 2 IF Plate
 2 Detector Control Grid
 2 Detector Cathode
 2 Detector Plate
 2 Det Plate to 80 Fil

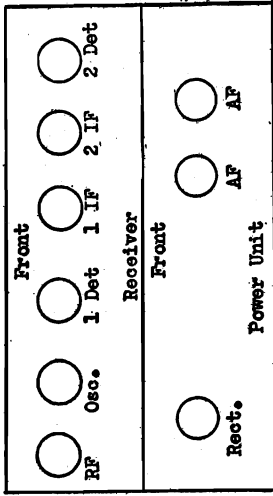

Volume Control at Maximum
*Not True Reading Due to Resistor in Circuit

Tube	Pin	Resistance	Notes
1	1	2.2	1.5K
1	2	2.2	1.5K
1	3	2.2	1.5K
1	4	2.2	1.5K
1	5	2.2	1.5K
1	6	2.2	1.5K
1	7	2.2	1.5K
1	8	2.2	1.5K
1	9	2.2	1.5K
1	10	2.2	1.5K
1	11	2.2	1.5K
1	12	2.2	1.5K
1	13	2.2	1.5K
1	14	2.2	1.5K
1	15	2.2	1.5K
1	16	2.2	1.5K
1	17	2.2	1.5K
1	18	2.2	1.5K
1	19	2.2	1.5K
1	20	2.2	1.5K
1	21	2.2	1.5K
1	22	2.2	1.5K
1	23	2.2	1.5K
1	24	2.2	1.5K
1	25	2.2	1.5K
1	26	2.2	1.5K
1	27	2.2	1.5K
1	28	2.2	1.5K
1	29	2.2	1.5K
1	30	2.2	1.5K
1	31	2.2	1.5K
1	32	2.2	1.5K
1	33	2.2	1.5K
1	34	2.2	1.5K
1	35	2.2	1.5K
1	36	2.2	1.5K
1	37	2.2	1.5K
1	38	2.2	1.5K
1	39	2.2	1.5K
1	40	2.2	1.5K
1	41	2.2	1.5K
1	42	2.2	1.5K
1	43	2.2	1.5K
1	44	2.2	1.5K
1	45	2.2	1.5K
1	46	2.2	1.5K
1	47	2.2	1.5K
1	48	2.2	1.5K
1	49	2.2	1.5K
1	50	2.2	1.5K
1	51	2.2	1.5K
1	52	2.2	1.5K
1	53	2.2	1.5K
1	54	2.2	1.5K
1	55	2.2	1.5K
1	56	2.2	1.5K
1	57	2.2	1.5K
1	58	2.2	1.5K
1	59	2.2	1.5K
1	60	2.2	1.5K
1	61	2.2	1.5K
1	62	2.2	1.5K
1	63	2.2	1.5K
1	64	2.2	1.5K
1	65	2.2	1.5K
1	66	2.2	1.5K
1	67	2.2	1.5K
1	68	2.2	1.5K
1	69	2.2	1.5K
1	70	2.2	1.5K
1	71	2.2	1.5K
1	72	2.2	1.5K
1	73	2.2	1.5K
1	74	2.2	1.5K
1	75	2.2	1.5K
1	76	2.2	1.5K
1	77	2.2	1.5K
1	78	2.2	1.5K
1	79	2.2	1.5K
1	80	2.2	1.5K
1	81	2.2	1.5K
1	82	2.2	1.5K
1	83	2.2	1.5K
1	84	2.2	1.5K
1	85	2.2	1.5K
1	86	2.2	1.5K
1	87	2.2	1.5K
1	88	2.2	1.5K
1	89	2.2	1.5K
1	90	2.2	1.5K
1	91	2.2	1.5K
1	92	2.2	1.5K
1	93	2.2	1.5K
1	94	2.2	1.5K
1	95	2.2	1.5K
1	96	2.2	1.5K
1	97	2.2	1.5K
1	98	2.2	1.5K
1	99	2.2	1.5K
1	100	2.2	1.5K

Volume Control at Minimum

Tube	Pin	Resistance	Notes
1	1	2.2	1.5K
1	2	2.2	1.5K
1	3	2.2	1.5K
1	4	2.2	1.5K
1	5	2.2	1.5K
1	6	2.2	1.5K
1	7	2.2	1.5K
1	8	2.2	1.5K
1	9	2.2	1.5K
1	10	2.2	1.5K
1	11	2.2	1.5K
1	12	2.2	1.5K
1	13	2.2	1.5K
1	14	2.2	1.5K
1	15	2.2	1.5K
1	16	2.2	1.5K
1	17	2.2	1.5K
1	18	2.2	1.5K
1	19	2.2	1.5K
1	20	2.2	1.5K
1	21	2.2	1.5K
1	22	2.2	1.5K
1	23	2.2	1.5K
1	24	2.2	1.5K
1	25	2.2	1.5K
1	26	2.2	1.5K
1	27	2.2	1.5K
1	28	2.2	1.5K
1	29	2.2	1.5K
1	30	2.2	1.5K
1	31	2.2	1.5K
1	32	2.2	1.5K
1	33	2.2	1.5K
1	34	2.2	1.5K
1	35	2.2	1.5K
1	36	2.2	1.5K
1	37	2.2	1.5K
1	38	2.2	1.5K
1	39	2.2	1.5K
1	40	2.2	1.5K
1	41	2.2	1.5K
1	42	2.2	1.5K
1	43	2.2	1.5K
1	44	2.2	1.5K
1	45	2.2	1.5K
1	46	2.2	1.5K
1	47	2.2	1.5K
1	48	2.2	1.5K
1	49	2.2	1.5K
1	50	2.2	1.5K
1	51	2.2	1.5K
1	52	2.2	1.5K
1	53	2.2	1.5K
1	54	2.2	1.5K
1	55	2.2	1.5K
1	56	2.2	1.5K
1	57	2.2	1.5K
1	58	2.2	1.5K
1	59	2.2	1.5K
1	60	2.2	1.5K
1	61	2.2	1.5K
1	62	2.2	1.5K
1	63	2.2	1.5K
1	64	2.2	1.5K
1	65	2.2	1.5K
1	66	2.2	1.5K
1	67	2.2	1.5K
1	68	2.2	1.5K
1	69	2.2	1.5K
1	70	2.2	1.5K
1	71	2.2	1.5K
1	72	2.2	1.5K
1	73	2.2	1.5K
1	74	2.2	1.5K
1	75	2.2	1.5K
1	76	2.2	1.5K
1	77	2.2	1.5K
1	78	2.2	1.5K
1	79	2.2	1.5K
1	80	2.2	1.5K
1	81	2.2	1.5K
1	82	2.2	1.5K
1	83	2.2	1.5K
1	84	2.2	1.5K
1	85	2.2	1.5K
1	86	2.2	1.5K
1	87	2.2	1.5K
1	88	2.2	1.5K
1	89	2.2	1.5K
1	90	2.2	1.5K
1	91	2.2	1.5K
1	92	2.2	1.5K
1	93	2.2	1.5K
1	94	2.2	1.5K
1	95	2.2	1.5K
1	96	2.2	1.5K
1	97	2.2	1.5K
1	98	2.2	1.5K
1	99	2.2	1.5K
1	100	2.2	1.5K

MODEL Radiola 86
Assembly Wiring

R. C. A. VICTOR CO., INC.

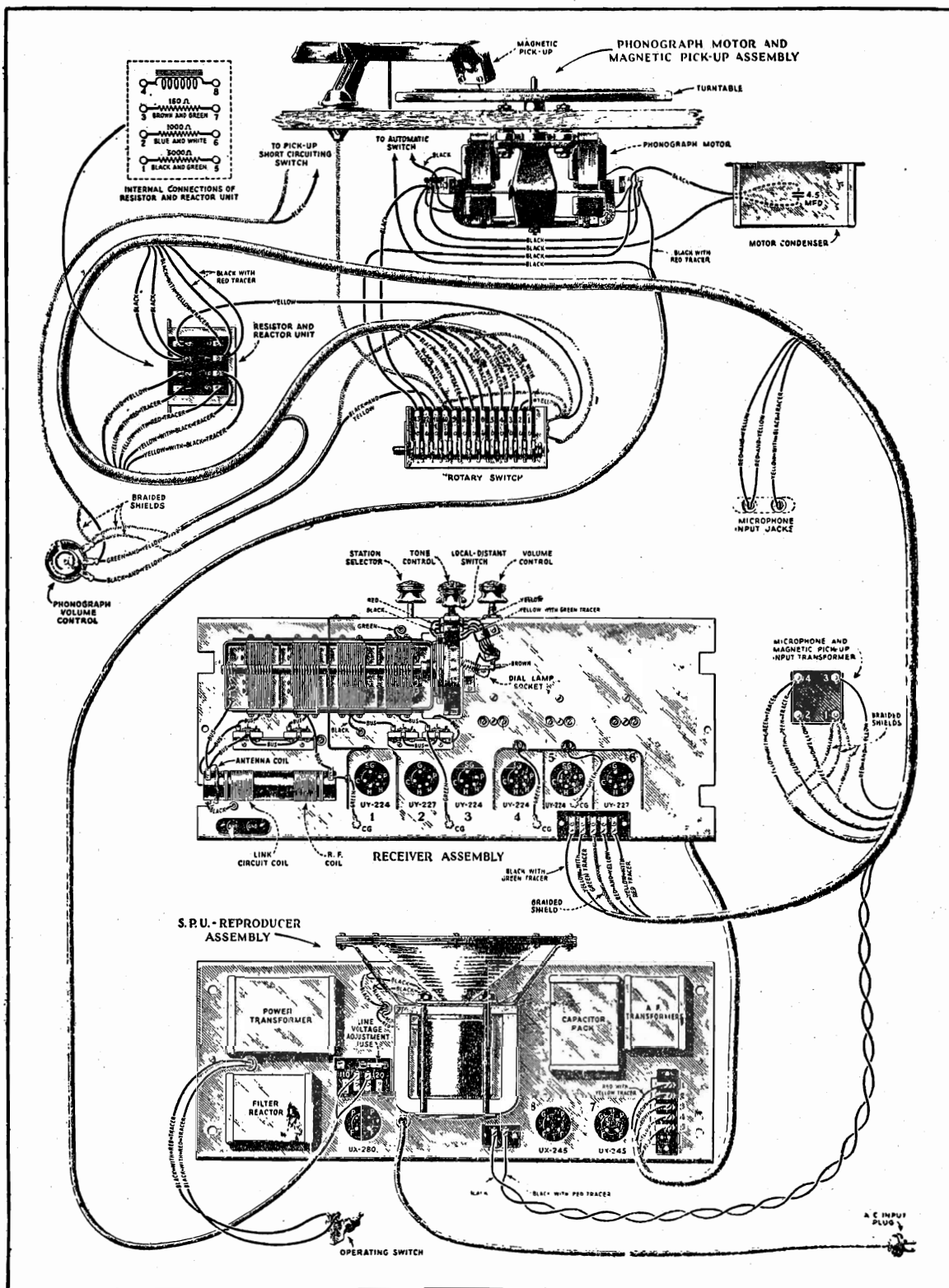

**MODEL SWA-2 SW Converter
Chassis - Parts List**

R. C. A. VICTOR CO., INC.

MODEL SWA-2 SHORT WAVE CONVERTER

RCA Victor Short Wave Converter SWA-2 is a t' ree tube, single control short wave unit designed to convert all short wave signals from 13.8-200 meters to a single frequency so that they may then be amplified by means of the usual broadcast receiver.

One Radiotron UY-224 is used as an R. F. Amplifying stage, one UY-224 as the detector and one UY-227 as the oscillator. Heater current for these Radiotrons is obtained from a small transformer incorporated in the unit. Plate supply is obtained from the broadcasting receiver.

A wafer connector is supplied that may be inserted under the tube socket when a receiver using a UX-280 rectifier and a filter in the negative side of the line is used. Under these conditions—most modern receivers are so designed that this is true—the plate supply to the converter is obtained through the contact on the wafer connector to the UX-280 filament. On receivers where this condition does not exist, but where Pentode output tubes are used, the wafer connector can be used to make connection to the screen grid of the Pentode. On receivers where neither condition exist any connection that gives a filtered D. C. output of from 180 to 260 volts between the contact and ground will be suitable.

Due to the SWA-2 being identical with the converter chassis used in the RO-23, reference to the RO-23 Service Notes should be made for data pertaining to Service work.

Stock No.	DESCRIPTION	List Price	Stock No.	DESCRIPTION	List Price
2747	Cap—Grid contactor cap—Package of 5.....	\$0.50	6109	Knob—Knob with pointer—Package of 5.....	\$1.75
2977	Knob—Station selector, or Resonator knob—Package of 5.....	2.50	6110	Dial lamp shield and indicator.....	.50
3058	Resistor—100,000 ohms—Carbon type—1 watt—Package of 5.....	2.50	6111	Escutcheon—Range switch knob escutcheon—Package of 5.....	1.80
3153	Resistor—1500 ohms—Carbon type—1 watt—Package of 5.....	2.75	6112	Cushion—Receiver chassis rubber cushions—Package of 5.....	.50
3285	Cord—Drive cord—Package of 5.....	1.00	7062	Capacitor—Adjustable capacitor—15-70 mmfd.....	1.00
3286	Spring—Drive cord tension spring—Package of 5.....	1.40	7298	Capacitor—.01 mfd.....	.80
3288	Socket—UY Radiotron socket—Complete with insulation strip.....	.50	7406	Capacitor—Double adjustable capacitor—One section 10-70 mmfd.—One section 800-1000 mmfd.....	1.10
3289	Contact lug—Complete with mounting rivets—Package of 10.....	.50	7407	Coil—Low frequency detector and oscillator coil.....	1.45
3290	Switch—Antenna—“Off and On”—Toggle type—2 used—Complete with mounting nut.....	1.00	7408	Coil—High frequency oscillator coil.....	1.85
3291	Board—Terminal board with two soldering terminals complete with mounting rivets—Located on switch bracket—Package of 5.....	.50	7410	Capacitor—Variable capacitor—7 plate—Complete with mounting nut and washers.....	1.75
3292	Drive shaft with pulley—Package of 5.....	2.35	8806	Transformer—Filament power transformer.....	3.25
3293	Coil—For resistor board assembly.....	.65	8807	Transformer—Filament power transformer—110 volts—25 cycle.....	5.75
6100	Coil—Coil assembly with mounting eyelet—For switch and bracket assembly.....	.75	8808	Transformer—Filament power transformer—220 volts—60 cycle.....	3.40
6101	Socket—Dial lamp socket and bracket with mounting rivets.....	.50	8809	Board—Resistor board less resistors, capacitors and coil.....	1.00
6102	Capacitor—1000 mmfd.—Package of 5.....	2.50	8810	Lever—Switch lever assembly—Comprising shaft, 3 switch levers and coupling bushing.....	.70
6103	Resistor—800 ohms—Carbon type—1 watt—Package of 5.....	2.00	8811	Switch—Range switch complete with mounting washer and nut.....	6.60
6104	Resistor—80,000 ohms—Carbon type—1 watt—Package of 5.....	2.00	8812	Capacitor—Variable tuning capacitor assembly.....	5.10
6105	Resistor—40,000 ohms—Carbon type—3 watt—Package of 5.....	2.00	8813	Dial drum and scale.....	1.20
6106	Coupling—Switch lever shaft coupling with 2 taper pins—Package of 5.....	.50	10820	Capacitor—100 mmfd.....	.50
6107	Switch—Toggle type—Power switch.....	1.00			
6108	Binding post—Complete with terminal lug, mounting washer and mounting nut—Package of 5.....	1.75			
				CABINET	
			3229	Escutcheon—Tuning dial escutcheon with mounting screws.....	.70
			6113	Foot—Cabinet felt foot—Package of 15.....	.50
			9399	Cabinet—Complete less equipment.....	12.00

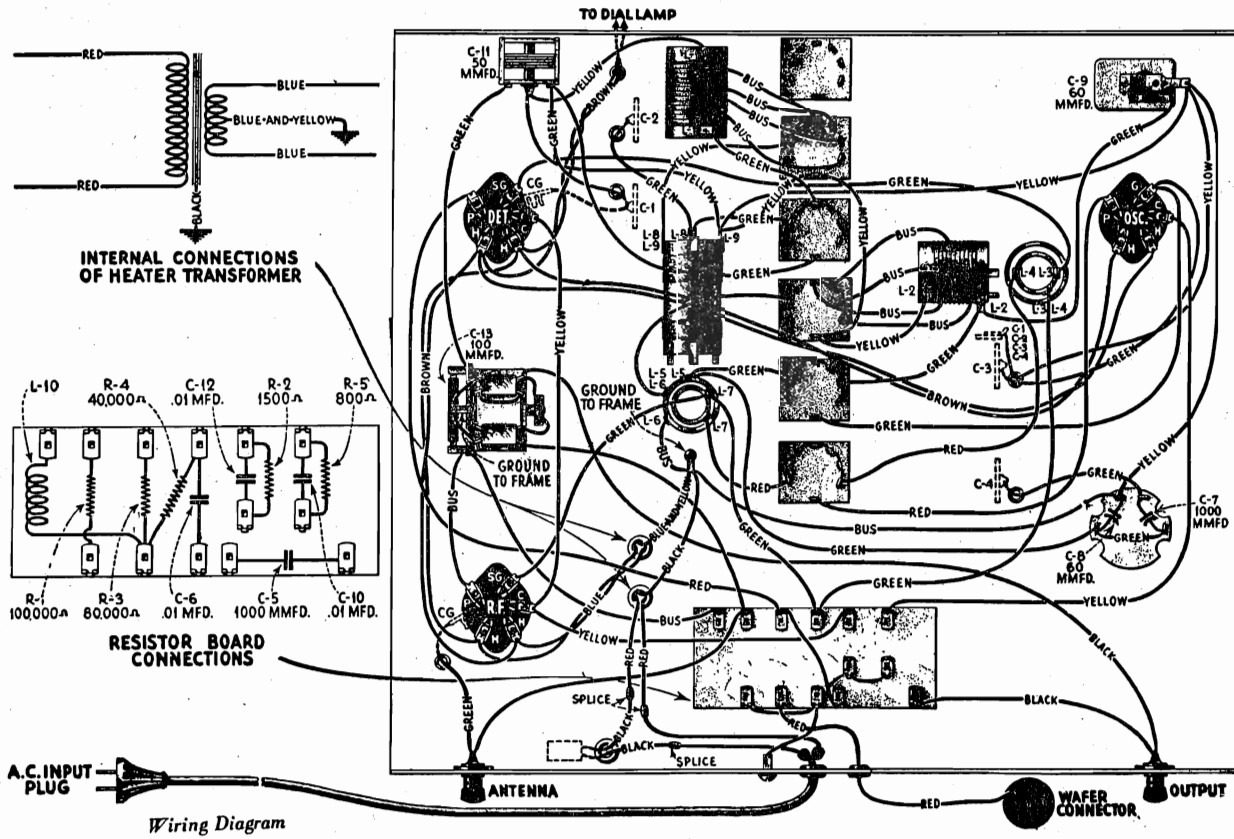

Model SW-2 (1931)

R. C. A. VICTOR CO., INC.

MODEL SWA-2 SW Converter Schematic

MODEL SWA-2 SHORT WAVE CONVERTER

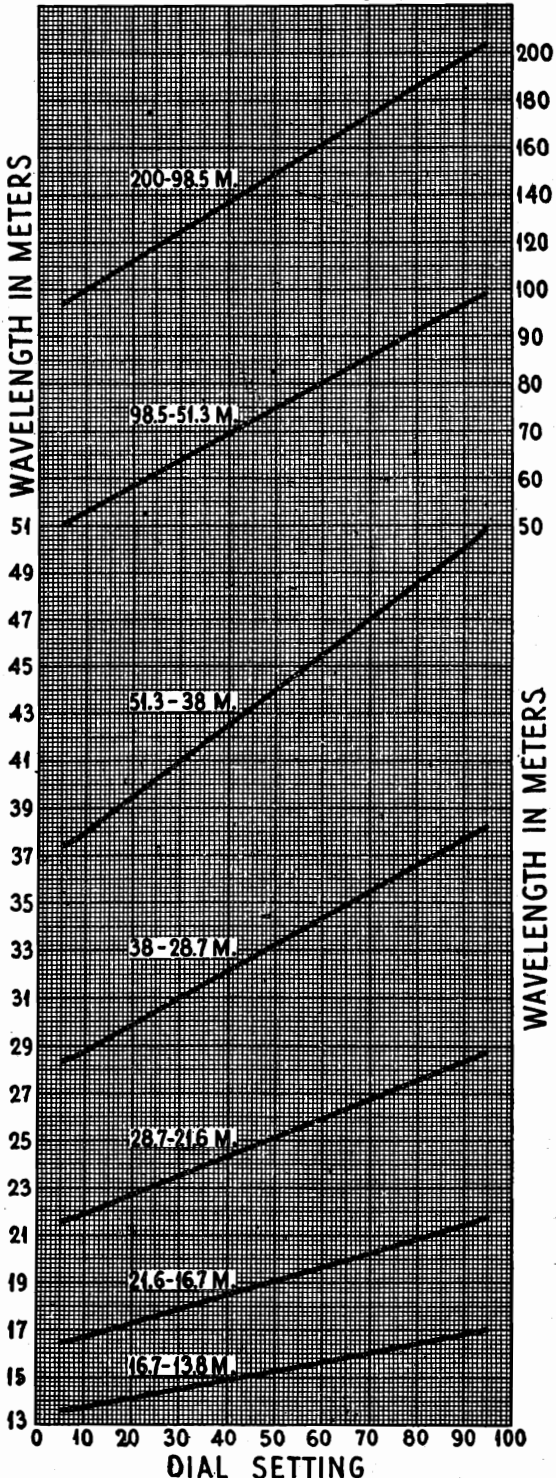
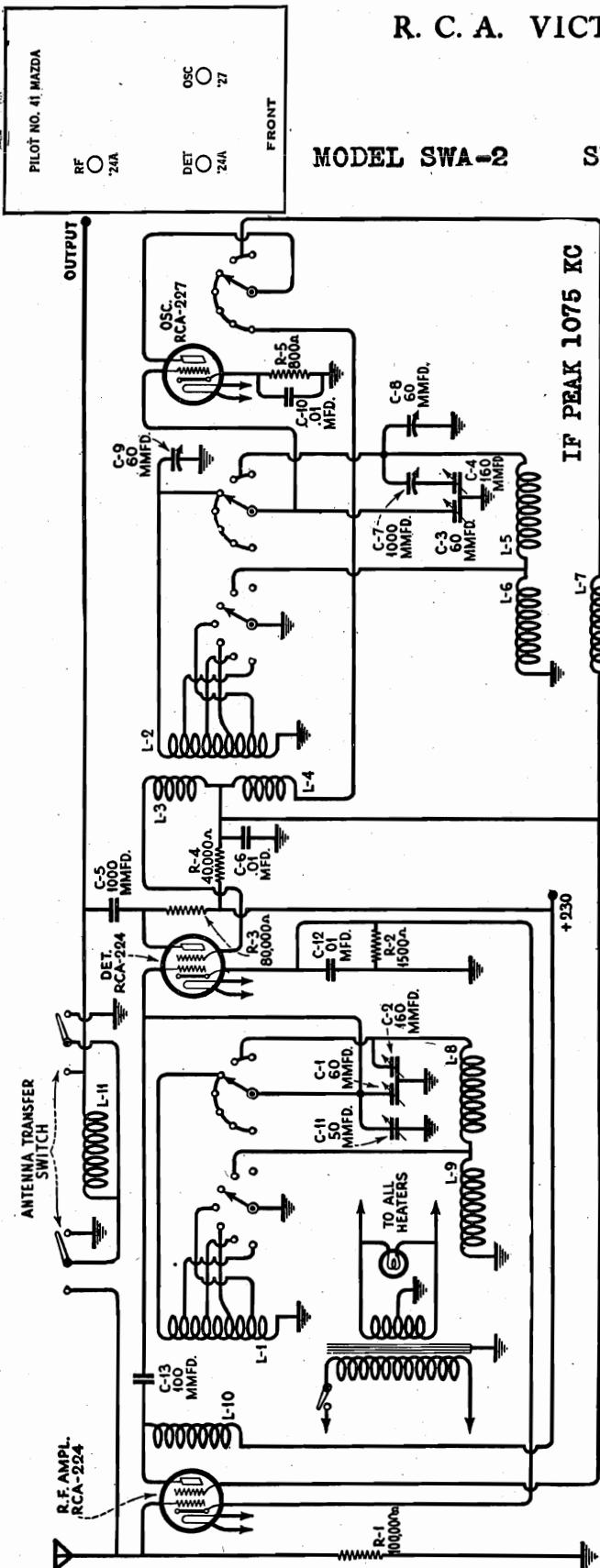

Voltage Rating 105-125 Volts and 200-250 Volts
 Frequency Rating 50-60 cycles and 25-40 cycles
 Power Consumption 20 Watts
 Recommended Antenna Length 25-75 feet

Approximate Calibration
 of Short Wave Tuning Dial of RO-23
 (with 1075 K.C. Intermediate Frequency).

MODEL 2-25
Portable
Victrola

R. C. A. VICTOR CO., INC.

REPLACEMENT PARTS

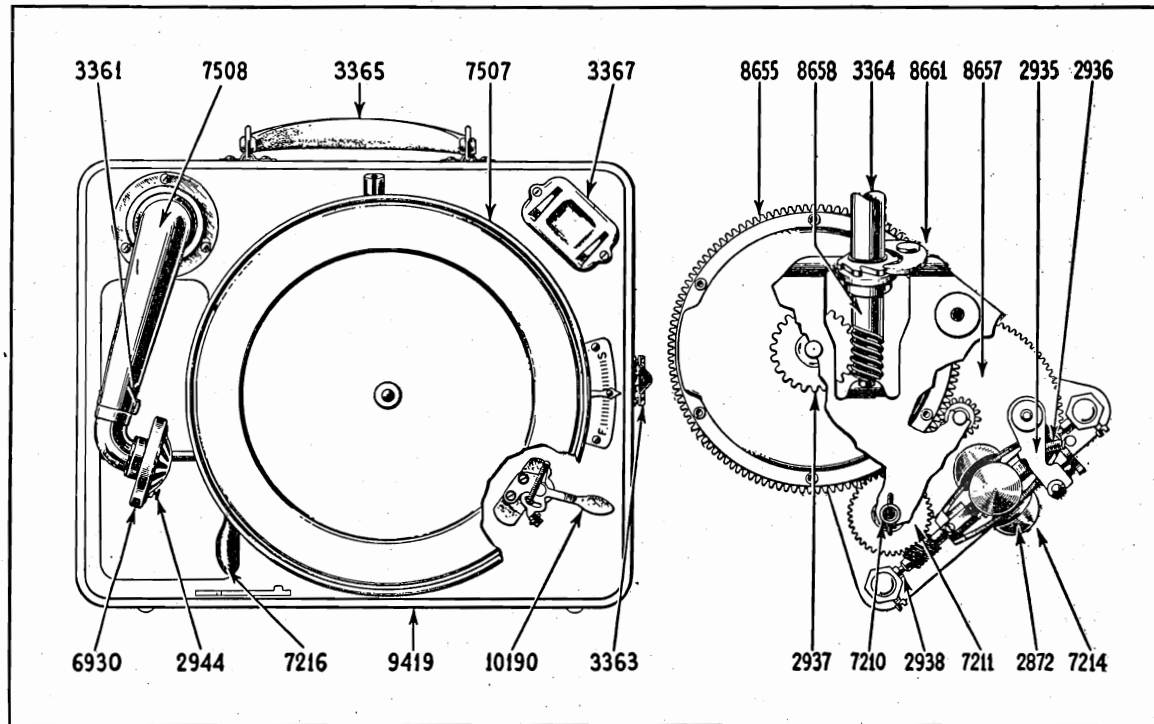

Figure 2—Cabinet, Motor Board and Motor Parts

Stock No.	DESCRIPTION	List Price	Stock No.	DESCRIPTION	List Price
2872	Governor ball and spring assembly—Comprising ball, spring, mounting screws and washers—Package of 5....	\$0.75	7211	Gear—Turntable spindle gear complete with set screw	\$0.50
2935	Lever—Speed regulator lever complete with stud and spring—Package of 2..	.50	7214	Governor assembly—Comprising governor spindle, disc, collar, governor balls and springs	2.50
2936	Spring—Speed regulator lever spring—Package of 1050	7216	Key—Winding key	1.00
2937	Gear—Winding gear and sleeve90	7226	RCA Victor motor oil—1 pint can.....	.50
2943	Cap—Turntable spindle cap screw—Package of 5	1.50	7227	RCA Victor motor grease—1 pint can..	.60
2944	Screw—Sound box needle screw—Package of 20	1.00	7228	RCA Victor spring lubricant—1 pint can.....	.65
2947	Leather—Friction leather for brake—Package of 2050	7447	Plate—Top plate assembly comprising top and bottom plates complete.....	3.00
3361	Hook—Tone arm and crank hook65	7507	Turntable—Complete with covering ...	2.90
3362	Hinge—Cabinet hinge with mounting screws—Package of 260	7508	Tube—Taper tube with pivot pin—Less sound box—Used with sound box No. 6930	2.20
3363	Lock—Lid lock with mounting screws..	.90	8655	Barrel—Spring barrel complete with main spring and driving gear—Less winding gear	3.00
3364	Extension—Winding shaft extension...	.70	8656	Spring—Main spring	1.15
3365	Handle—Carrying handle complete with bracket and mounting rivets90	8657	Gear—Intermediate gear complete with pinion and shaft70
3366	Scale—Speed regulator scale complete with mounting screws50	8658	Shaft — Winding shaft — Comprising shaft, collar, pin, ratchet and washer—Less winding extension	1.25
3367	Holder—Needle holder75	8661	Motor—Motor complete with spindle cap	12.00
6930	Sound box—Complete with needle screw	4.50	9419	Cabinet complete—Less mechanism ...	(Price on application)
7210	Spindle—Turntable spindle complete with pins and ball bearing—Less gear	.80	10190	Brake—Turntable hand brake—Package of 250

R. C. A. VICTOR CO. INC.

MODEL 2-25
Portable
Victrola

RCA Victor Portable Victrola Model 2-25

The RCA Victor Portable Victrola Model 2-25 is a small portable type reproducing instrument built into a metal cabinet resembling a small suitcase. Excellent quality, high output and good mechanical construction are features of this instrument.

LUBRICATION

Premature wear, noisy operation and failure of parts are direct results of failure to clean and lubricate the motor at necessary intervals. The various bearings and gears of the motor should be cleaned and lubricated at least once every six months. In addition to the regular lubrication, all motor parts should be covered with a light film of oil to prevent rusting. Use only RCA Victor Motor Oil and Motor Grease when lubricating this instrument.

Initial Operation. When the instrument is first played, wind the motor and allow it to run down completely several times. This insures a complete distribution of lubricant within the spring barrel. Maximum run is dependent on this point.

The speed of the motor should be adjusted so that the turntable revolves at 78 R. P. M. This can be checked by means of a Stroboscope Disc in conjunction with a source of A. C. illumination of proper frequency for the disc used or by counting the revolutions. In both cases a record must be playing in the normal manner when the check is made.

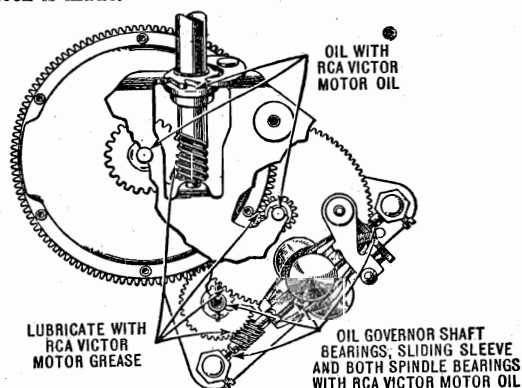

Figure 1—Lubrication Diagram of Model 2-25

Motor. Figure 1 shows a view of the motor with the top plate removed. Before lubricating the parts shown in this illustration, a thorough cleaning with carbon tetrachloride (Carbona) or gasoline is necessary. If necessary disassemble the entire motor for such cleaning.

Tone Arm. The joint between the taper tube and the sound chamber must be free to swing easily without play and be sealed with grease. This bearing is accessible when the three mounting screws are removed. Failure to seal this joint will result in poor quality. Unnecessary friction will cause undue record wear.

MOTOR

The motor used in Model 2-25 is of simple design and will give excellent performance. If kept clean and properly lubricated, little service attention will be required. The

following points may prove useful when it is necessary to effect repairs. Before doing any work on the motor the machine must be allowed to run down completely.

Removing Motor from Cabinet. To remove the motor from the cabinet proceed as follows:

- (a) Unscrew the spindle cap and remove the turntable.
- (b) Remove the four machine screws that hold the motor in place. The motor may then be removed through the hole in the motor board.

Changing Motor Springs. Should a spring break and require replacement the best method to make a repair is to replace the entire spring barrel. While the cost of the spring barrel is greater than that of the spring alone, the saving in labor will usually justify such replacement. Unless the serviceman is experienced in handling springs of this type, the following directions should be followed carefully:

- (a) Disassemble the motor and remove the spring barrel. Remove the winding gear.
- (b) Place the gear flat on a piece of metal and file off the ends of the six rivets. Remove the rivets and gear.
- (c) Place the palm of the right hand over the closed end of the barrel, making sure that the fingers do not protrude beyond the open side. Firmly hold the barrel, open side downward over a large can or barrel. With the left hand pull the center turns of the spring out. As soon as the spring starts, pull the left hand clear of the can holding the spring barrel firmly until the spring is entirely clear.
- (d) A new coiled spring may prove extremely dangerous if not properly handled. Read these instructions and work very carefully especially if not experienced in work of this kind. The new spring is furnished coiled and with a heavy wire clamp holding the spring tightly wound. Pull out about one foot of the spring. Then with the spring flat on a table gently tap the ring until it comes to the edge. Do not push the clamp so close to the edge that it will not hold the spring.

Place the hook end of the spring over the barrel hook. Wind the exposed end into the barrel and then insert the entire spring in the barrel allowing the clamp to be on the outer edge. Place a block over the entire spring and force the spring into the barrel thereby releasing the clamp.

- (f) Place a tablespoonful of spring lubricant between the spring leaves and in the center of the spring.
- (g) Place the gear in position and rivet it with six rivets to the spring barrel. Use a small punch for flattening the ends of the rivets. Place the gear on a flat surface while re-riveting the barrel to it.
- (h) Reassemble the motor in the reverse manner of that used to dismantle it.

Winding Shaft Binding. A heavy jar may cause the motor to shift slightly on the motor board and produce binding of the winding shaft against the motor board. Loosening the motor mounting screws and shifting the motor to its proper position will correct this condition.

R. C. A. VICTOR CO., INC.

MODEL 2-65
Turntable

The RCA Victor Portable Victrola Model 2-65 is a small portable type instrument built into a cabinet resembling a small suitcase. Excellent quality, high output and good mechanical construction are features of this instrument.

LUBRICATION

Premature wear, noisy operation and failure of parts are direct results of failure to clean and lubricate the motor at necessary intervals. The various bearings and gears of the motor should be cleaned and lubricated at least once every six months. In addition to the regular lubrication, all parts should be covered with a light film of oil to prevent rusting. Use only RCA Victor Motor Oil and Motor Grease when lubricating this instrument.

Initial Operation. When the instrument is first played, wind the motor and allow it to run down completely several times. This insures a complete distribution of lubricant within the spring barrel. Maximum run is dependent on this point.

The speed of the motor should be adjusted so that the turntable revolves at 78 R.P.M. This can be checked by means of a Stroboscope Disc in conjunction with a source of A.C. illumination of proper frequency for the disc used or by counting the revolutions. In both cases a Record must be playing in the normal manner when the check is made.

Motor. Figure 1 shows a view of the motor with the top plate removed. Before lubricating the parts shown in this illustration, a thorough cleaning with carbon tetra-chloride (Carbona) or gasoline is necessary. If necessary disassemble the entire motor for such cleaning.

Tone Arm. The joint between the goose neck and tone arm and that between the tone arm and sound chamber must be free to swing easily without play and be sealed with grease. The goose neck is detached or adjusted by means of two collars that hold it in place. The bearing between the tone arm and sound box is accessible when the swivel and three mounting screws are removed. Failure to seal these joints will result in poor quality. Unnecessary friction at either of these points will cause undue record wear.

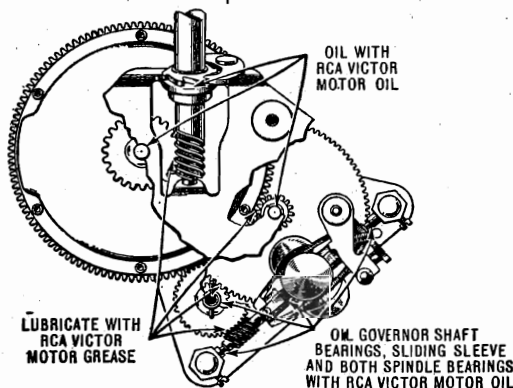

Figure 1—Lubrication Diagram of Model 2-65

AUTOMATIC STOP MECHANISM

The Automatic Stop Mechanism is simple of design and effective in operation. Figure 2 shows its principal parts.

Failure to Start. Should pulling the tone arm to the right and then placing the sound box on the record fail to start the motor, it may be due to:

(a) Improper location of base plate. Loosen the screws A, B, and C and shift position of mechanism counter-clockwise until proper operation is secured.

(b) Worn or rounded surfaces at point D. Square these points with a small file.

(c) Insufficient tension at spring E. Remove a few turns or replace spring.

Failure to Trip. Should the mechanism fail to stop the motor at the end of a Victor record having the eccentric groove, check the following:

(a) Improperly adjusted base plate. Loosen screws A, B, and C and shift the mechanism clockwise until proper operation is obtained.

(b) Loose or improperly adjusted latch plate.

(c) Insufficient tension at spring F. Remove several turns or replace spring.

Tripping during Operation. Premature tripping during the operation of a record may be caused by:

(a) Binding at bearing G. Clean and lubricate this bearing.

(b) Insufficient bite at point D. Loosen the screws A, B, and C and adjust the base plate so that a larger bite is obtained at point D.

MOTOR

The motor used in Model 2-65 is of simple design and will give excellent performance. If kept clean and properly lubricated, little service attention will be required. The following points may prove useful when it is necessary to effect repairs.

Removing Motor from Cabinet. To remove the motor from the cabinet proceed as follows:

(a) Unscrew the spindle cap and remove the turntable.

(b) Remove the eight machine screws that hold the motor board in place. The sound deflector is also removed.

(c) Remove the three motor mounting screws, together with the one holding the speed regulator lever. Remove this lever. The motor board may now be turned over and the motor pulled clear and placed in a position convenient for work. The various parts are

easy of access and adjustments or replacements are simple to make.

Changing Motor Springs. Should a spring break and require replacement the best method to make a repair is to replace the entire spring barrel. While the cost of the spring barrel is greater than that of the spring alone, the saving in labor will usually justify such replacement. Unless the serviceman is experienced in handling springs of this type, the following directions should be followed carefully:

(a) Disassemble the motor and remove the spring barrel. Remove the winding gear.

(b) Place the gear flat on a piece of metal and file off the ends of the six rivets. Remove the rivets and gear.

(c) Place the palm of the right hand over the closed end of the barrel, making sure that the fingers do not protrude beyond the open side. Firmly hold the barrel, open side downward over a large can or barrel. With the left hand pull the

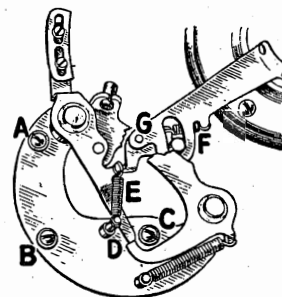

Figure 2—Automatic Stop Mechanism

center turns of the spring out. As soon as the spring starts, pull the left hand clear of the can holding the spring barrel firmly until the spring is entirely clear.

(d) The new spring is furnished coiled and with a heavy wire clamp. Hit the spring flat on a table thereby driving the clamp to one edge of the spring. Grasp the exposed part of the spring firmly with the right hand and pull the clamp off with the left hand. Allow the spring to gradually release its tension in the right hand and then unwind it completely.

(e) Place the hooked end of the spring over the barrel hook and wind the spring into the barrel toward the center. Be careful to push each turn completely inside the barrel before winding on the next turn.

(f) Place a tablespoonful of spring lubricant between the spring leaves and in the center of the spring.

(g) Place the gear in position and rivet it with six rivets to the spring barrel. Use a small punch for flattening the ends of the rivets. Place the gear on a flat surface while re-riveting the barrel to it.

(h) Reassemble the motor in the reverse manner of that used to dismantle it.

Winding Shaft Binding. A heavy jar may cause the motor to shift slightly on the motor board and produce binding of the winding shaft against the motor board. Loosening the motor mounting screws and shifting the motor to its proper position will correct this condition.

MODEL 2-65
PORTABLE VICTROLA

R. C. A. VICTOR CO., INC.

MODEL Photophone PG-32
Voltage
Exciter Lamp Chassis

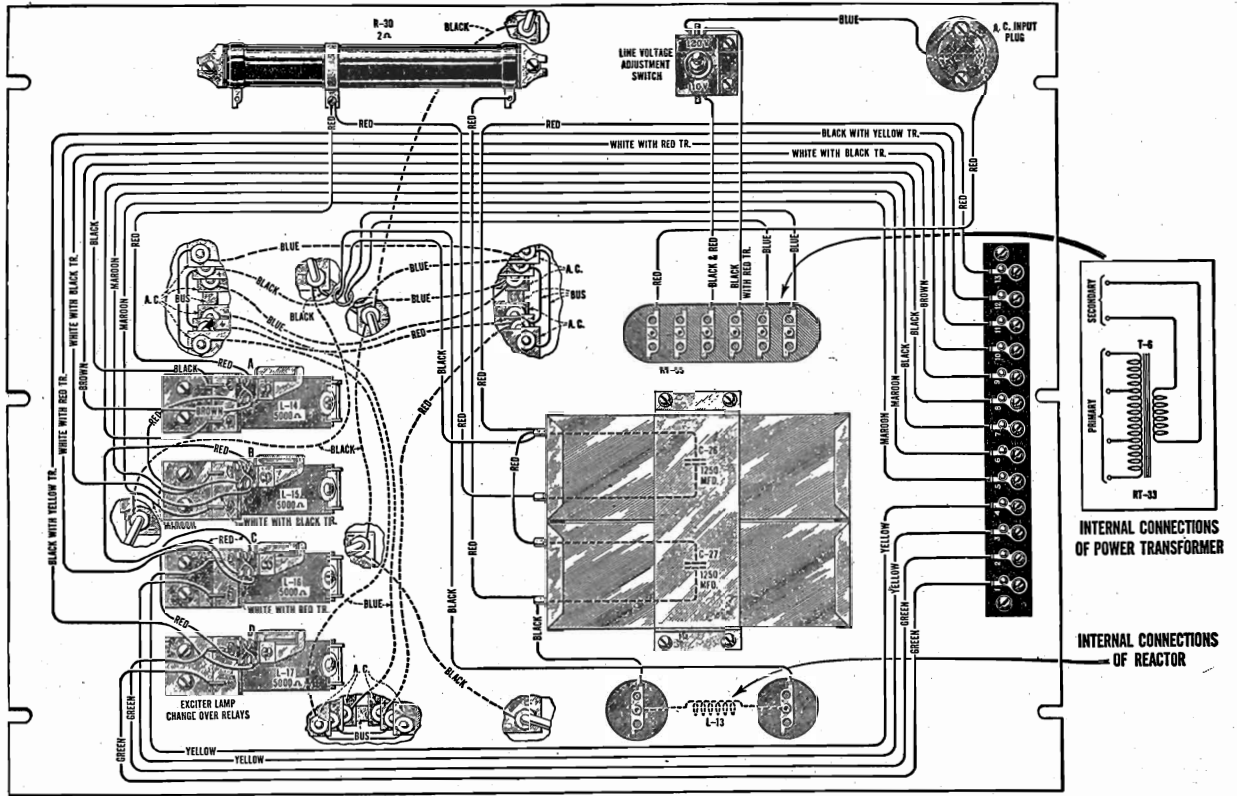

Exciter Lamp Supply Panel Wiring

Service Data

(2) RADIOTRON SOCKET VOLTAGES

The following voltages taken at each Radiotron socket with the amplifier in operating condition should prove of value when checking with test sets such as the Photophone KR-13 Multitester or the Weston Model 547, Type 3, or other giving similar readings. The plate currents shown are not necessarily accurate for each tube, as the cable in the test set will cause some circuits to oscillate, due to its added capacity. Small variations of voltages will be caused by different tubes and line voltages. Therefore, the following values must be taken as approximately those that will be found under varying conditions. The numbers in column 1 indicate the tube socket numbers shown in Figure 21.

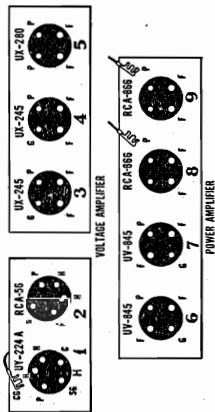

Figure 21—Radiotron Socket Layout

Due to the voltage drop in the plate resistors caused by the current consumed in the test voltmeter, the screen grid and plate voltage readings obtained for the Radiotrons UY-224-A and RCA-56 are not true values.

To measure the plate current of the Radiotrons UY-845 a low range voltmeter or a millivoltmeter is required. The meter should be connected to a Yaxley No. 75 phone plug or a similar plug and the plug inserted into the plate current metering jacks on the base of the power amplifier.

Two millivolts read on the test meter equals one milliampere of plate current.

RADIOTRON SOCKET VOLTAGES 120 Volt A. C. Line VOLTAGE AMPLIFIER

Radiotron No.	Control Grid to Cathode or Filament Volts	Screen Grid to Cathode or Filament Volts	Plate to Cathode or Filament Volts	Plate Current M. A.	Filament or Heater Volts
1. UY-224-A	1.2	45	90	1.0	2.2
2. RCA-56	6.0	—	115	2.5	2.2
3. UX-245	48.0	—	250	30.0	2.3
4. UX-245	—	—	250	30.0	2.3
5. UX-280	—	—	—	50.0	5.0

POWER AMPLIFIER

6. UY-845	—	—	—	60-75	10.0
7. UY-845	—	—	—	60-75	10.0

R. C. A. VICTOR CO., INC.

MODEL Photophone PG-38
Schematic

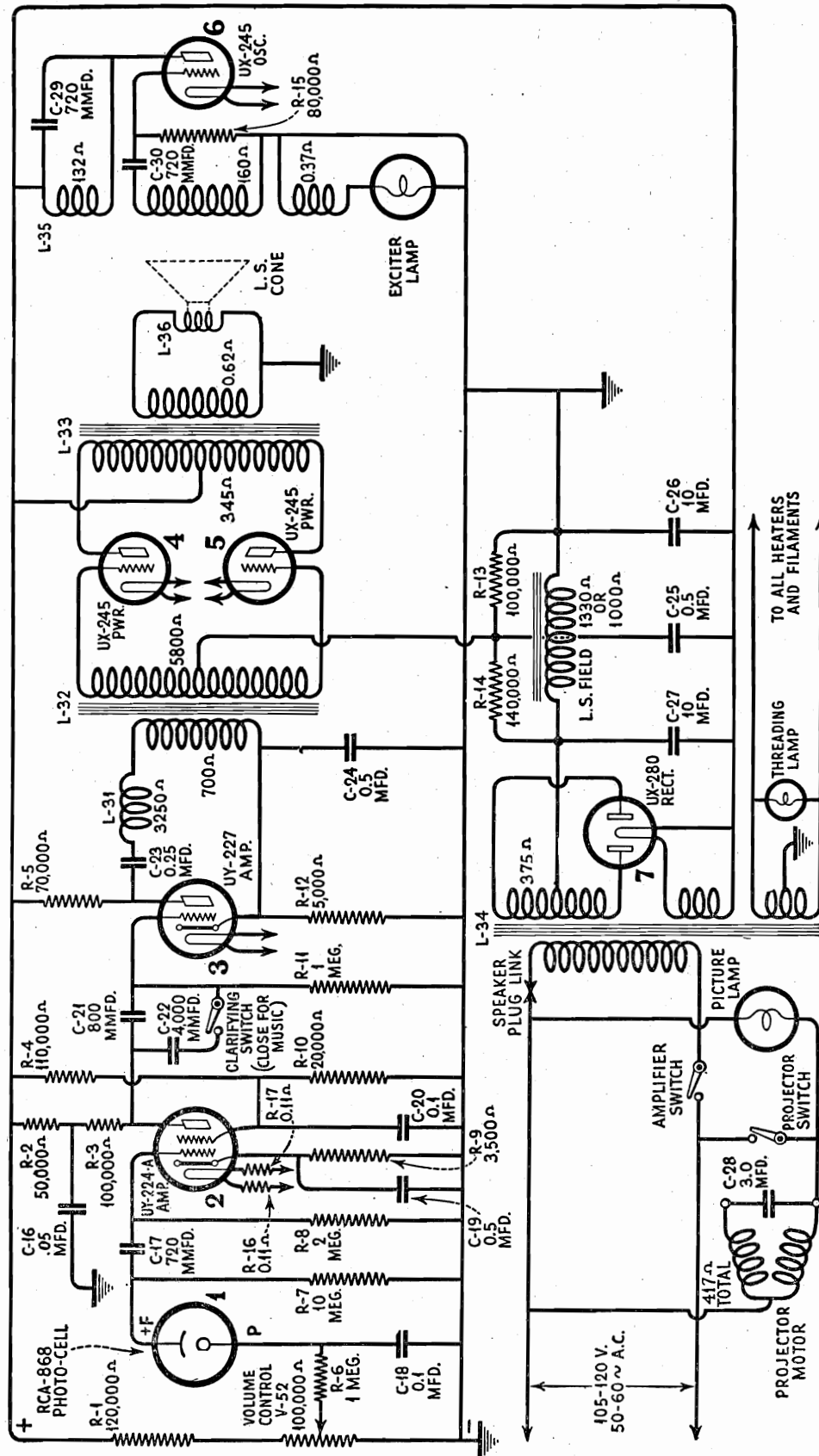

MODEL Photophone PG-38
Chassis

R. C. A. VICTOR CO., INC.

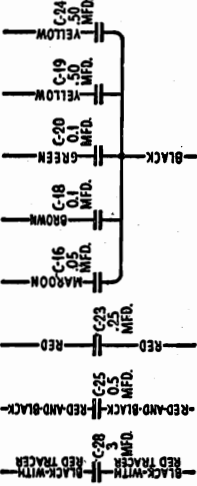
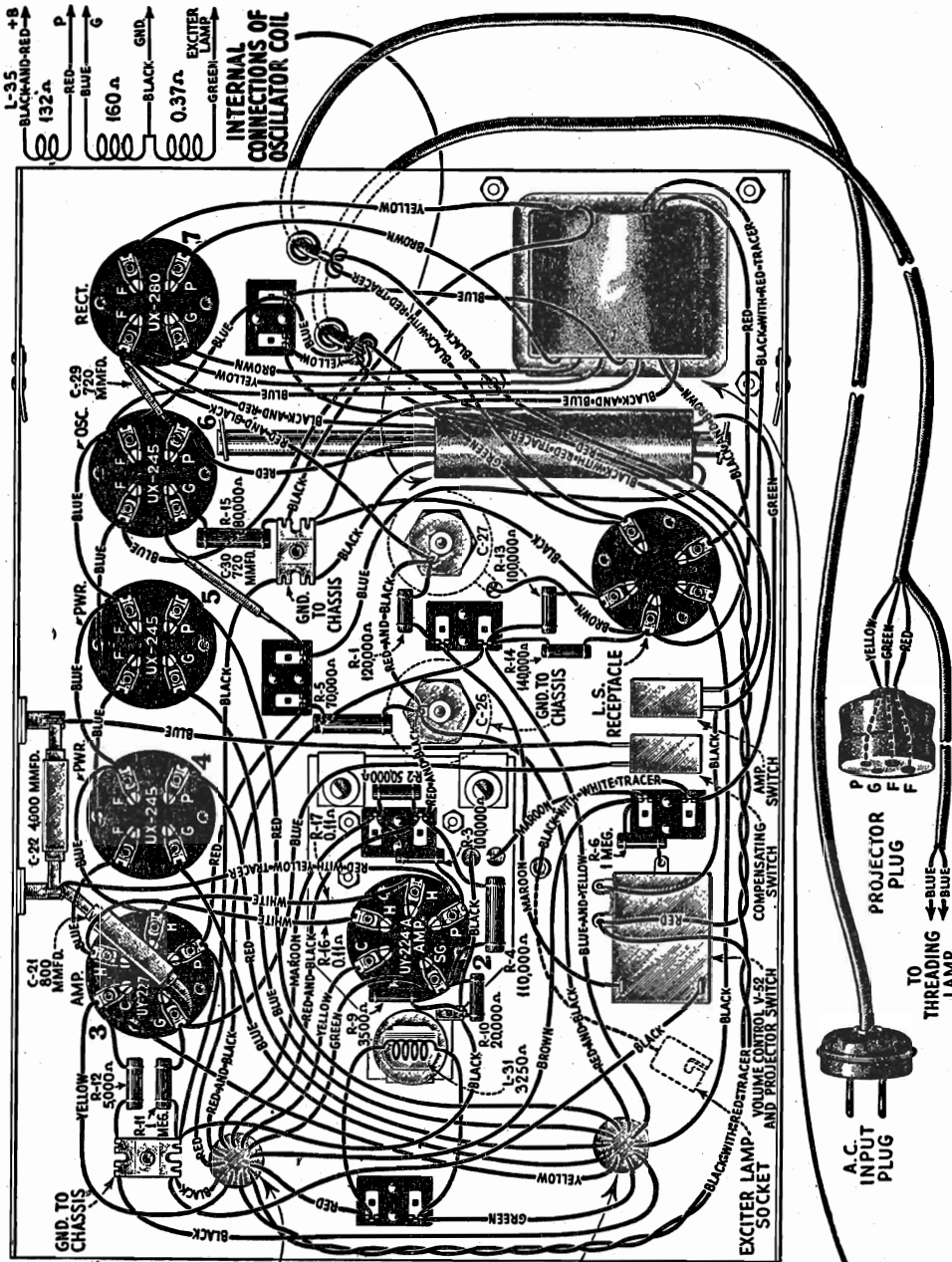

INTERNAL CONNECTIONS OF CAPACITOR PACK

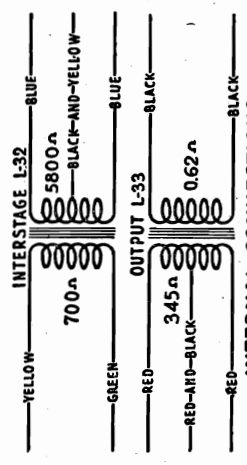

INTERNAL CONNECTIONS OF TRANSFORMER PACK

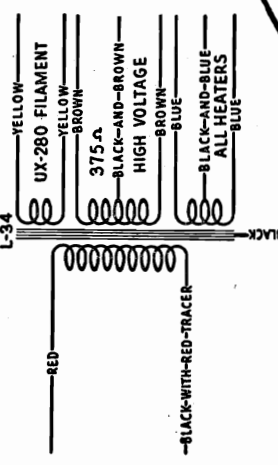

INTERNAL CONNECTIONS OF POWER TRANSFORMER

Radioiron No.	Control Grid to Cathode or Filament Volts	Screen Grid to Cathode or Filament Volts	Plate to Cathode or Filament Volts	Plate Current M. A.	Filament or Heater Volts
2-UY-224-A	0.1	28	150	0.5	2.3
3-UY-227	1.5		110	2.0	2.5
4-UX-245	35		240	30	2.5
5-UX-245	35		240	30	2.5
6-UX-245 Occ.	75		240	25	2.5

Volume Control at Minimum
115 Volt Line

R. C. A. VICTOR CO., INC.

MODEL Photophone PK-25
Schematic
Chassis

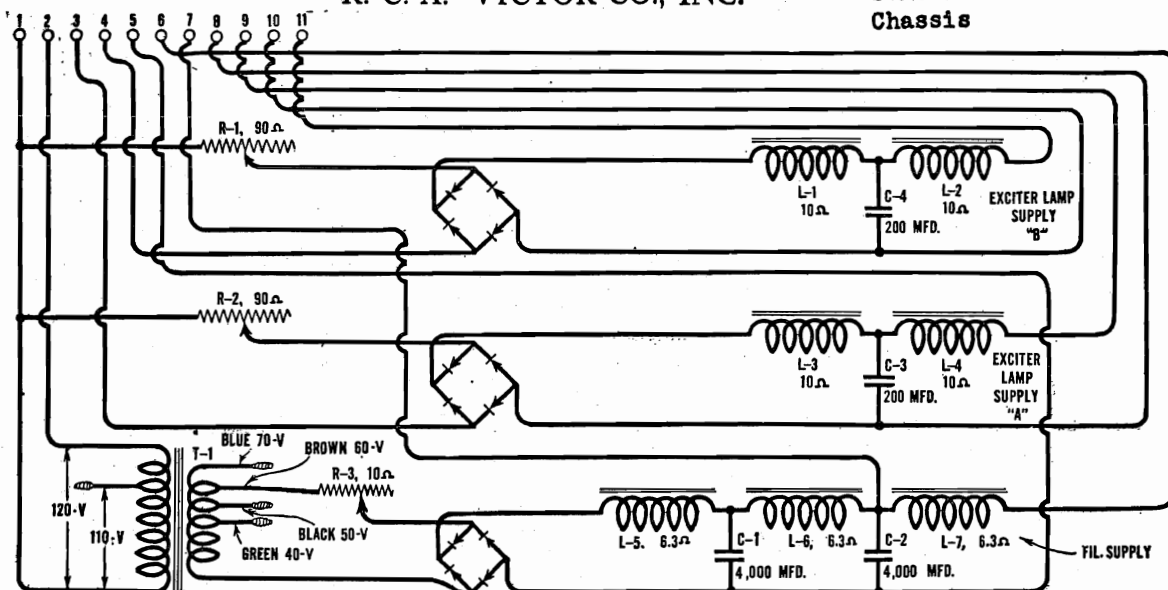

SCHEMATIC DIAGRAM PK-25 UNIT

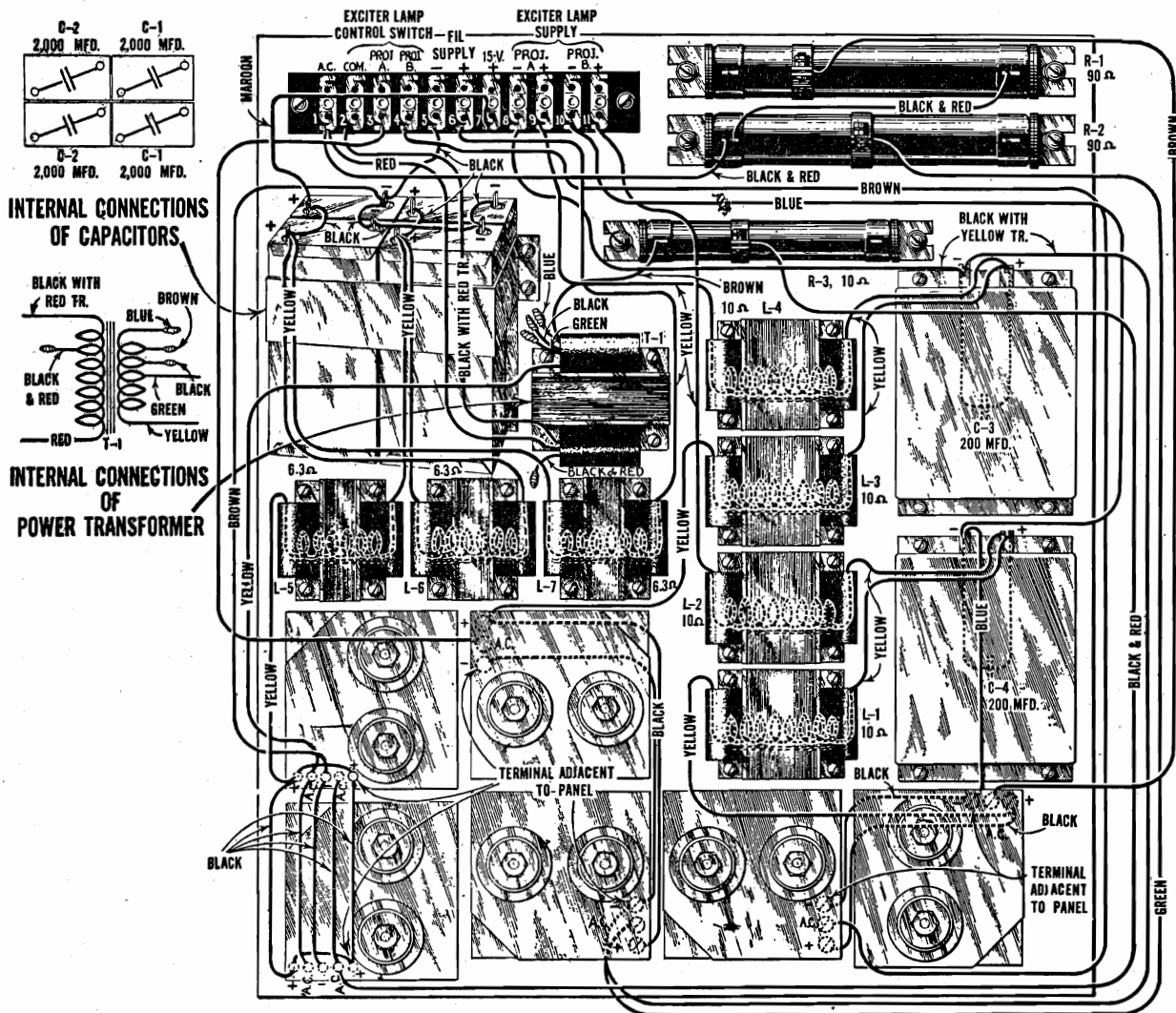

WIRING DIAGRAM PK-25 UNIT

R.C.A. RADIOTRON CO.

Detectors
Amplifiers

TUBE SYMBOLS
AND BOTTOM VIEWS OF
SOCKET CONNECTIONS

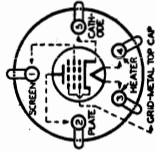
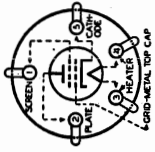
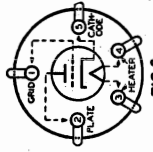
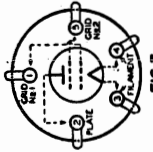
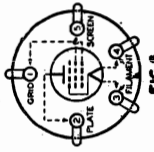

TYPE	PURPOSE	BASE	SOCKET CONNECTIONS	DIMENSIONS MAX. OVERALL	CATHODE TYPE	RATING			PLATE SUPPLY VOLTS	NEGATIVE GRID BIAS VOLTS	SCREEN VOLTS	PLATE CURR. MILLIAMPS	SCREEN CURR. MILLIAMPS	MUTUAL INDUCTANCE MICROHMS	VOLTAGE GAIN FACTOR	OHMS LOAD FOR STARTED OUTPUT	POWER OUTPUT MILLIWATTS
						FILAMENT VOLTS	AMPLIFIED SUPPLY	MAX. PLATE									
RCA-247	RADIO FREQ. CONVERTER	SMALL 7-PIN	FIG. 20	4 1/2" x 1 1/2"	HEATER	2.5	0.8	A ₁ 250	250	3.0	100	4.0	2.0	300000	1000	3.5 MA.	
RCA-287	SUPER-DETECTOR & AMPLIFIER	SMALL 7-PIN	FIG. 21	4 1/2" x 1 1/2"	HEATER	2.5	0.8	A ₁ 250	250	3.0	100	4.0	2.0	300000	1000	3.5 MA.	
RCA-287	SUPER-DETECTOR & AMPLIFIER	SMALL 7-PIN	FIG. 21	4 1/2" x 1 1/2"	HEATER	2.5	0.8	A ₁ 250	250	3.0	100	4.0	2.0	300000	1000	3.5 MA.	
RCA-647	SUPER-DETECTOR & AMPLIFIER	SMALL 7-PIN	FIG. 20	4 1/2" x 1 1/2"	HEATER	2.5	0.8	A ₁ 250	250	3.0	100	4.0	2.0	300000	1000	3.5 MA.	
RCA-687	SUPER-DETECTOR & AMPLIFIER	SMALL 7-PIN	FIG. 21	4 1/2" x 1 1/2"	HEATER	2.5	0.8	A ₁ 250	250	3.0	100	4.0	2.0	300000	1000	3.5 MA.	
RCA-687	SUPER-DETECTOR & AMPLIFIER	SMALL 7-PIN	FIG. 21	4 1/2" x 1 1/2"	HEATER	2.5	0.8	A ₁ 250	250	3.0	100	4.0	2.0	300000	1000	3.5 MA.	
UX-501-A	AMPLIFIER	SMALL 7-PIN	FIG. 21	4 1/2" x 1 1/2"	HEATER	2.5	0.8	A ₁ 250	250	3.0	100	4.0	2.0	300000	1000	3.5 MA.	
UX-112-A	AMPLIFIER	SMALL 7-PIN	FIG. 21	4 1/2" x 1 1/2"	HEATER	2.5	0.8	A ₁ 250	250	3.0	100	4.0	2.0	300000	1000	3.5 MA.	
RCA-22	RADIO FREQ. CONVERTER	SMALL 7-PIN	FIG. 4	5 1/2" x 1 1/2"	HEATER	2.5	0.8	A ₁ 250	250	3.0	100	4.0	2.0	300000	1000	3.5 MA.	
RCA-24-A	BIASED DETECTOR	SMALL 7-PIN	FIG. 9	5 1/2" x 1 1/2"	HEATER	2.5	0.8	A ₁ 250	250	3.0	100	4.0	2.0	300000	1000	3.5 MA.	
RCA-24-A	BIASED DETECTOR	SMALL 7-PIN	FIG. 9	5 1/2" x 1 1/2"	HEATER	2.5	0.8	A ₁ 250	250	3.0	100	4.0	2.0	300000	1000	3.5 MA.	
RCA-26	AMPLIFIER	SMALL 7-PIN	FIG. 8	4 1/2" x 1 1/2"	HEATER	2.5	0.8	A ₁ 250	250	3.0	100	4.0	2.0	300000	1000	3.5 MA.	
UY-227	AMPLIFIER	SMALL 7-PIN	FIG. 8	4 1/2" x 1 1/2"	HEATER	2.5	0.8	A ₁ 250	250	3.0	100	4.0	2.0	300000	1000	3.5 MA.	
UY-227	AMPLIFIER	SMALL 7-PIN	FIG. 8	4 1/2" x 1 1/2"	HEATER	2.5	0.8	A ₁ 250	250	3.0	100	4.0	2.0	300000	1000	3.5 MA.	
RCA-30	BIASED DETECTOR	SMALL 7-PIN	FIG. 1	4 1/2" x 1 1/2"	HEATER	2.5	0.8	A ₁ 250	250	3.0	100	4.0	2.0	300000	1000	3.5 MA.	
RCA-32	RADIO FREQ. CONVERTER	SMALL 7-PIN	FIG. 4	5 1/2" x 1 1/2"	HEATER	2.5	0.8	A ₁ 250	250	3.0	100	4.0	2.0	300000	1000	3.5 MA.	
RCA-34	BIASED DETECTOR	SMALL 7-PIN	FIG. 4	5 1/2" x 1 1/2"	HEATER	2.5	0.8	A ₁ 250	250	3.0	100	4.0	2.0	300000	1000	3.5 MA.	
RCA-34	BIASED DETECTOR	SMALL 7-PIN	FIG. 4	5 1/2" x 1 1/2"	HEATER	2.5	0.8	A ₁ 250	250	3.0	100	4.0	2.0	300000	1000	3.5 MA.	
RCA-35	BIASED DETECTOR	SMALL 7-PIN	FIG. 4A	5 1/2" x 1 1/2"	HEATER	2.5	0.8	A ₁ 250	250	3.0	100	4.0	2.0	300000	1000	3.5 MA.	
RCA-35	BIASED DETECTOR	SMALL 7-PIN	FIG. 4A	5 1/2" x 1 1/2"	HEATER	2.5	0.8	A ₁ 250	250	3.0	100	4.0	2.0	300000	1000	3.5 MA.	
RCA-36	RADIO FREQ. CONVERTER	SMALL 7-PIN	FIG. 9	5 1/2" x 1 1/2"	HEATER	2.5	0.8	A ₁ 250	250	3.0	100	4.0	2.0	300000	1000	3.5 MA.	
RCA-36	RADIO FREQ. CONVERTER	SMALL 7-PIN	FIG. 9	5 1/2" x 1 1/2"	HEATER	2.5	0.8	A ₁ 250	250	3.0	100	4.0	2.0	300000	1000	3.5 MA.	
RCA-36	RADIO FREQ. CONVERTER	SMALL 7-PIN	FIG. 9	5 1/2" x 1 1/2"	HEATER	2.5	0.8	A ₁ 250	250	3.0	100	4.0	2.0	300000	1000	3.5 MA.	
RCA-37	AMPLIFIER	SMALL 7-PIN	FIG. 8	4 1/2" x 1 1/2"	HEATER	2.5	0.8	A ₁ 250	250	3.0	100	4.0	2.0	300000	1000	3.5 MA.	
RCA-37	AMPLIFIER	SMALL 7-PIN	FIG. 8	4 1/2" x 1 1/2"	HEATER	2.5	0.8	A ₁ 250	250	3.0	100	4.0	2.0	300000	1000	3.5 MA.	
RCA-39	BIASED DETECTOR	SMALL 7-PIN	FIG. 9A	5 1/2" x 1 1/2"	HEATER	2.5	0.8	A ₁ 250	250	3.0	100	4.0	2.0	300000	1000	3.5 MA.	
RCA-44	SUPER-DETECTOR & AMPLIFIER	SMALL 7-PIN	FIG. 10	5 1/2" x 1 1/2"	HEATER	2.5	0.8	A ₁ 250	250	3.0	100	4.0	2.0	300000	1000	3.5 MA.	
RCA-44	SUPER-DETECTOR & AMPLIFIER	SMALL 7-PIN	FIG. 10	5 1/2" x 1 1/2"	HEATER	2.5	0.8	A ₁ 250	250	3.0	100	4.0	2.0	300000	1000	3.5 MA.	
RCA-55	BIASED DETECTOR	SMALL 7-PIN	FIG. 10	5 1/2" x 1 1/2"	HEATER	2.5	0.8	A ₁ 250	250	3.0	100	4.0	2.0	300000	1000	3.5 MA.	
RCA-55	BIASED DETECTOR	SMALL 7-PIN	FIG. 10	5 1/2" x 1 1/2"	HEATER	2.5	0.8	A ₁ 250	250	3.0	100	4.0	2.0	300000	1000	3.5 MA.	
RCA-56	AMPLIFIER	SMALL 7-PIN	FIG. 10	5 1/2" x 1 1/2"	HEATER	2.5	0.8	A ₁ 250	250	3.0	100	4.0	2.0	300000	1000	3.5 MA.	
RCA-56	AMPLIFIER	SMALL 7-PIN	FIG. 10	5 1/2" x 1 1/2"	HEATER	2.5	0.8	A ₁ 250	250	3.0	100	4.0	2.0	300000	1000	3.5 MA.	
RCA-57	BIASED DETECTOR	SMALL 7-PIN	FIG. 11	4 1/2" x 1 1/2"	HEATER	2.5	0.8	A ₁ 250	250	3.0	100	4.0	2.0	300000	1000	3.5 MA.	
RCA-57	BIASED DETECTOR	SMALL 7-PIN	FIG. 11	4 1/2" x 1 1/2"	HEATER	2.5	0.8	A ₁ 250	250	3.0	100	4.0	2.0	300000	1000	3.5 MA.	
RCA-58	BIASED DETECTOR	SMALL 7-PIN	FIG. 11	4 1/2" x 1 1/2"	HEATER	2.5	0.8	A ₁ 250	250	3.0	100	4.0	2.0	300000	1000	3.5 MA.	
RCA-58	BIASED DETECTOR	SMALL 7-PIN	FIG. 11	4 1/2" x 1 1/2"	HEATER	2.5	0.8	A ₁ 250	250	3.0	100	4.0	2.0	300000	1000	3.5 MA.	
RCA-75	BIASED DETECTOR	SMALL 7-PIN	FIG. 13	4 1/2" x 1 1/2"	HEATER	2.5	0.8	A ₁ 250	250	3.0	100	4.0	2.0	300000	1000	3.5 MA.	
RCA-75	BIASED DETECTOR	SMALL 7-PIN	FIG. 13	4 1/2" x 1 1/2"	HEATER	2.5	0.8	A ₁ 250	250	3.0	100	4.0	2.0	300000	1000	3.5 MA.	
RCA-77	BIASED DETECTOR	SMALL 7-PIN	FIG. 11	4 1/2" x 1 1/2"	HEATER	2.5	0.8	A ₁ 250	250	3.0	100	4.0	2.0	300000	1000	3.5 MA.	
RCA-77	BIASED DETECTOR	SMALL 7-PIN	FIG. 11	4 1/2" x 1 1/2"	HEATER	2.5	0.8	A ₁ 250	250	3.0	100	4.0	2.0	300000	1000	3.5 MA.	
RCA-78	BIASED DETECTOR	SMALL 7-PIN	FIG. 11	4 1/2" x 1 1/2"	HEATER	2.5	0.8	A ₁ 250	250	3.0	100	4.0	2.0	300000	1000	3.5 MA.	
RCA-78	BIASED DETECTOR	SMALL 7-PIN	FIG. 11	4 1/2" x 1 1/2"	HEATER	2.5	0.8	A ₁ 250	250	3.0	100	4.0	2.0	300000	1000	3.5 MA.	
RCA-85	BIASED DETECTOR	SMALL 7-PIN	FIG. 13	4 1/2" x 1 1/2"	HEATER	2.5	0.8	A ₁ 250	250	3.0	100	4.0	2.0	300000	1000	3.5 MA.	
UY-189	BIASED DETECTOR	SMALL 7-PIN	FIG. 10	5 1/2" x 1 1/2"	HEATER	2.5	0.8	A ₁ 250	250	3.0	100	4.0	2.0	300000	1000	3.5 MA.	
UY-189	BIASED DETECTOR	SMALL 7-PIN	FIG. 10	5 1/2" x 1 1/2"	HEATER	2.5	0.8	A ₁ 250	250	3.0	100	4.0	2.0	300000	1000	3.5 MA.	
RCA-98A	AMPLIFIER	SMALL 7-PIN	FIG. 1	4 1/2" x 1 1/2"	HEATER	2.5	0.8	A ₁ 250	250	3.0	100	4.0	2.0	300000	1000	3.5 MA.	
RCA-98A	AMPLIFIER	SMALL 7-PIN	FIG. 1	4 1/2" x 1 1/2"	HEATER	2.5	0.8	A ₁ 250	250	3.0	100	4.0	2.0	300000	1000	3.5 MA.	

TUBE SYMBOLS
AND BOTTOM VIEWS OF
SOCKET CONNECTIONS

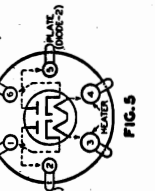
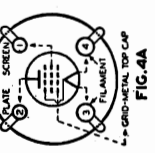
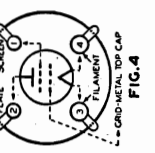
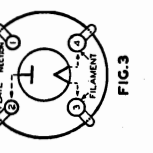
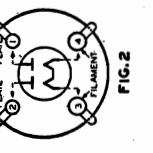
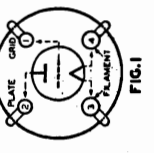

RADIO RECEPTOR CO.

MODEL PMA-1
MODEL P-50-W

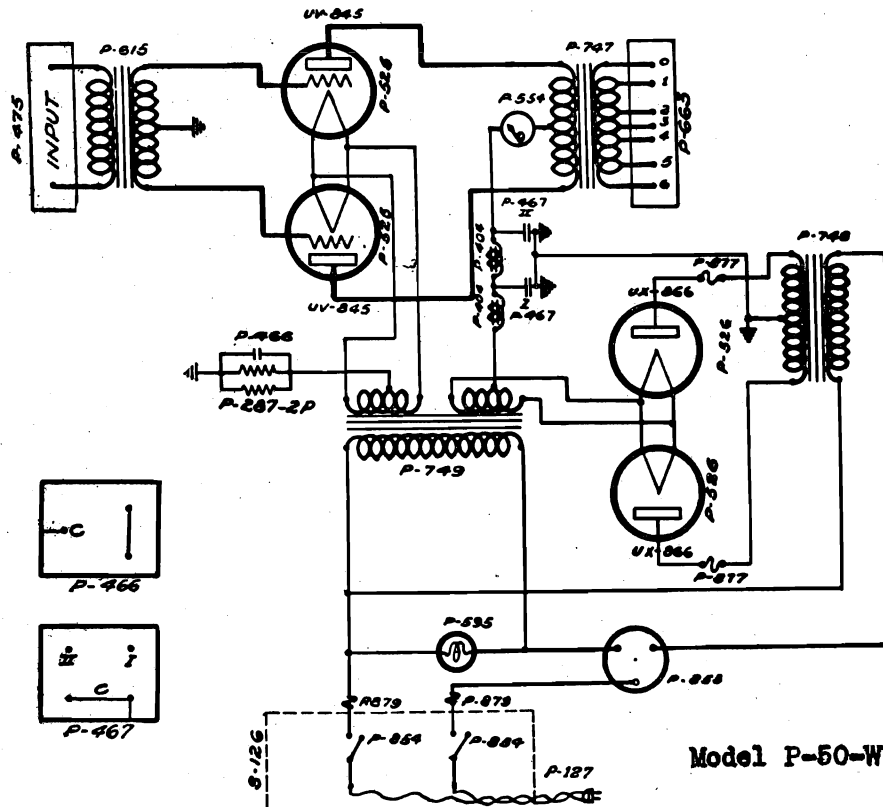

Model P-50-W

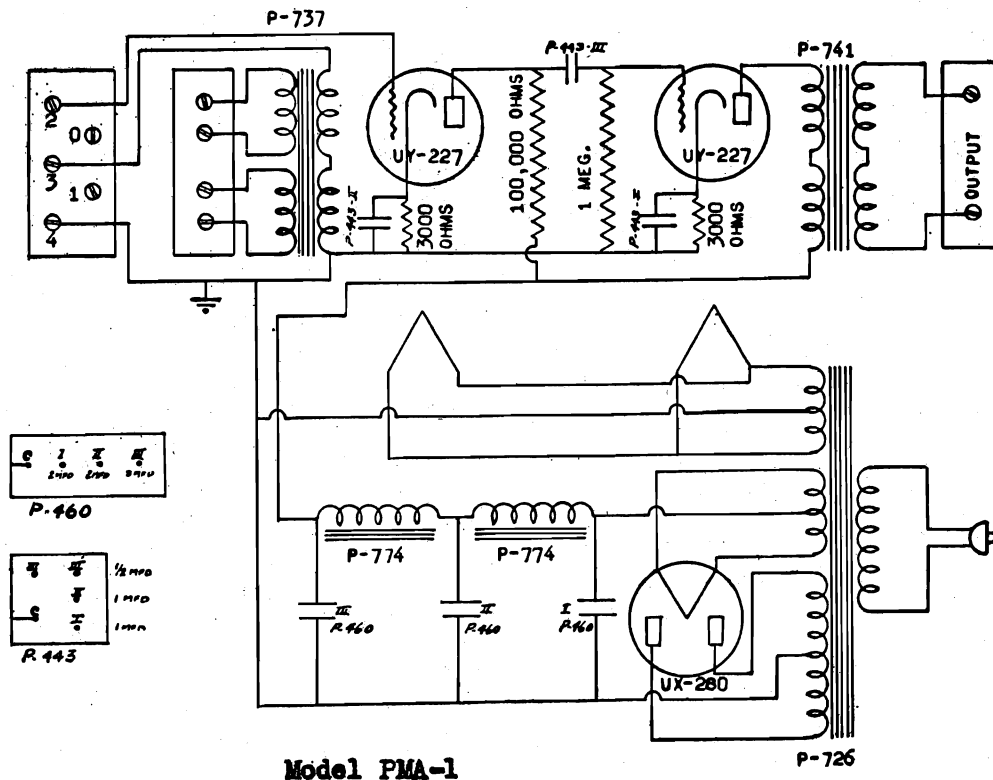

Model PMA-1

RAD OLEK

MODEL Monroe-Marvelo 30
 MODEL Marvelo "6" Midget
 MODEL Radolek 5 Tube Super

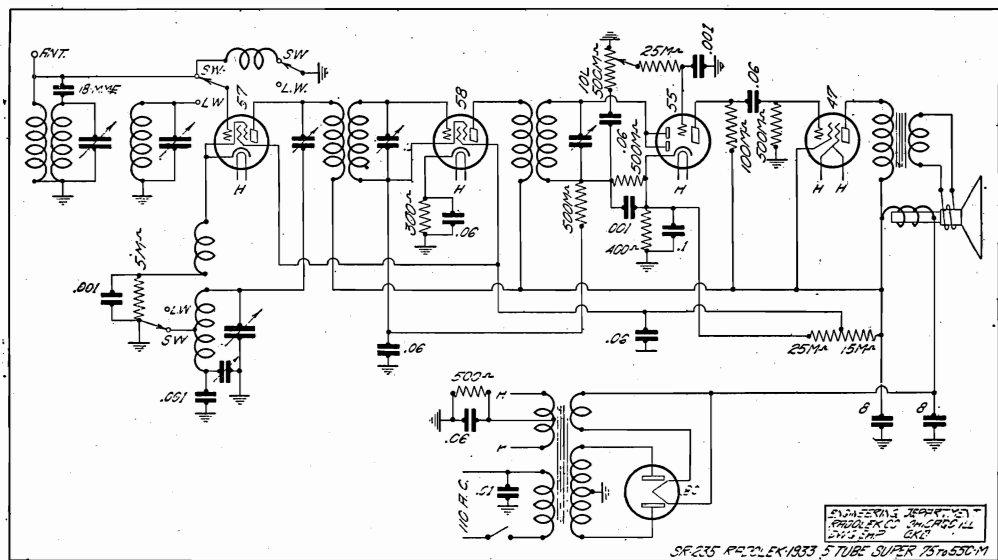
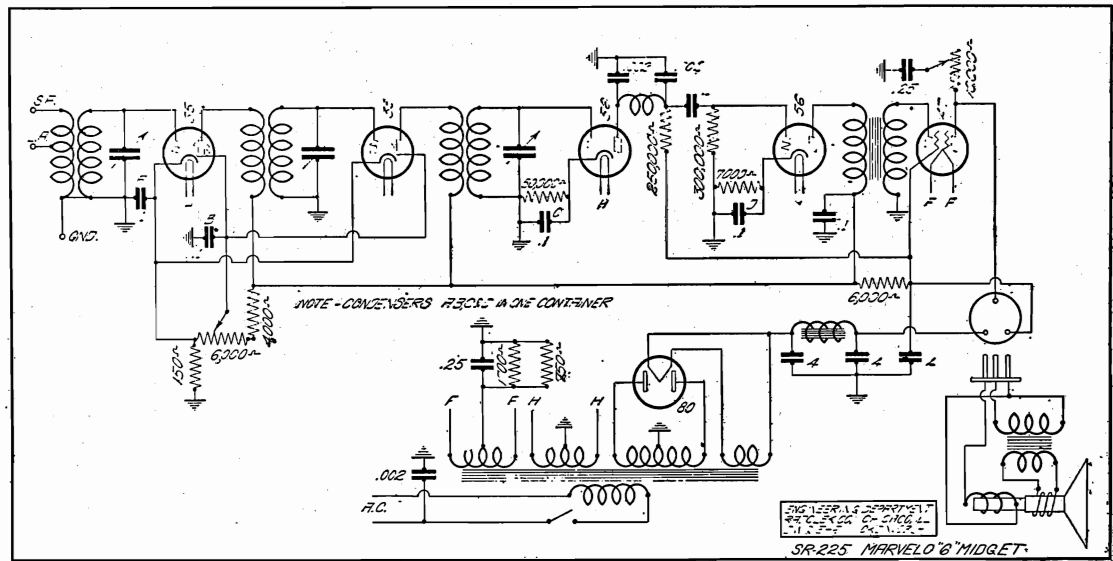
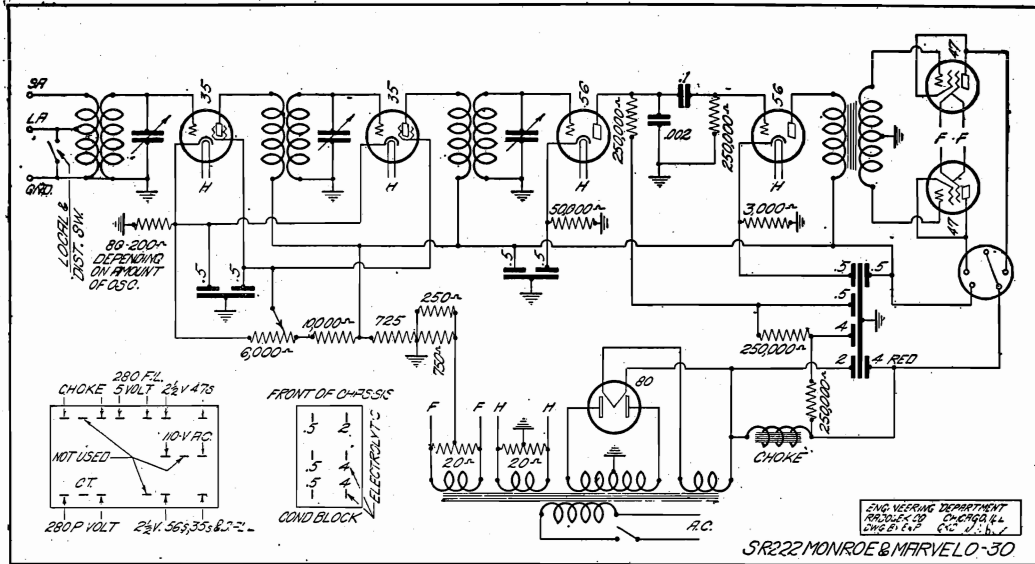

READRITE METER WORKS

MODEL 400 Tube Tester
MODEL 405 Tube Checker

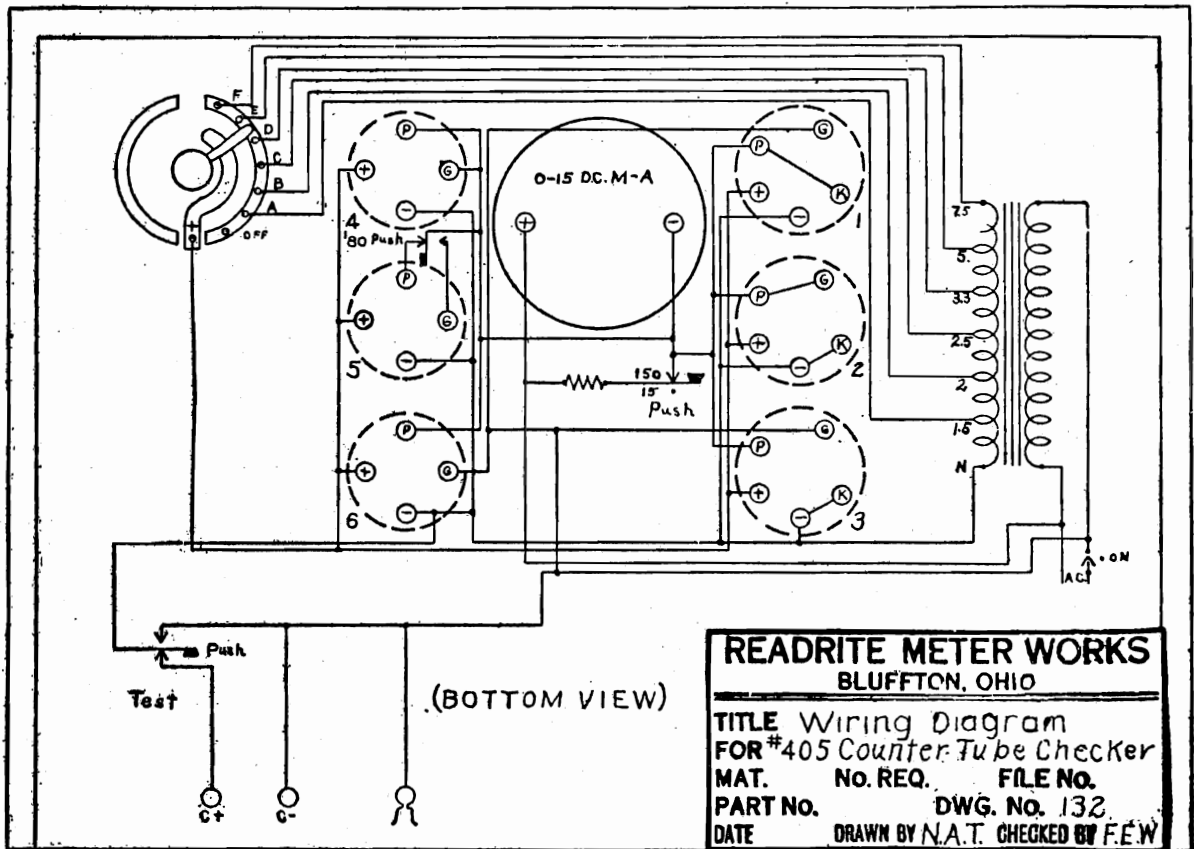
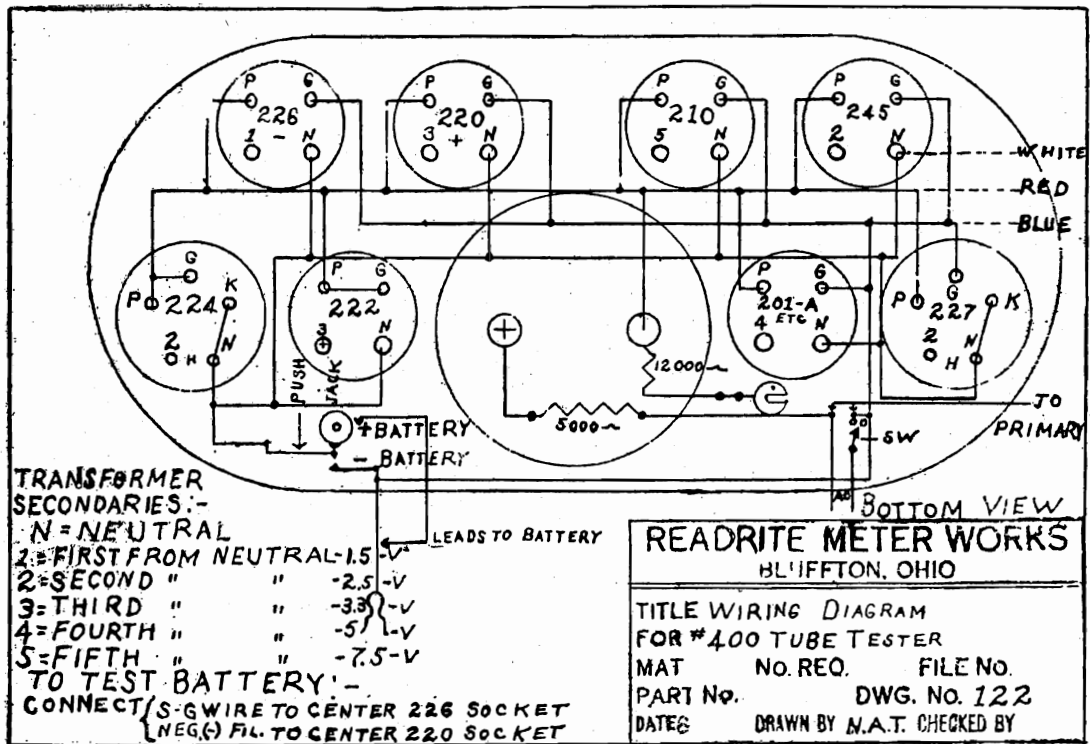

MODEL 10-3
MODEL 15-3

REMLER COMPANY, LTD.

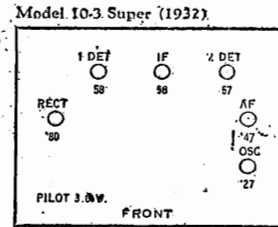
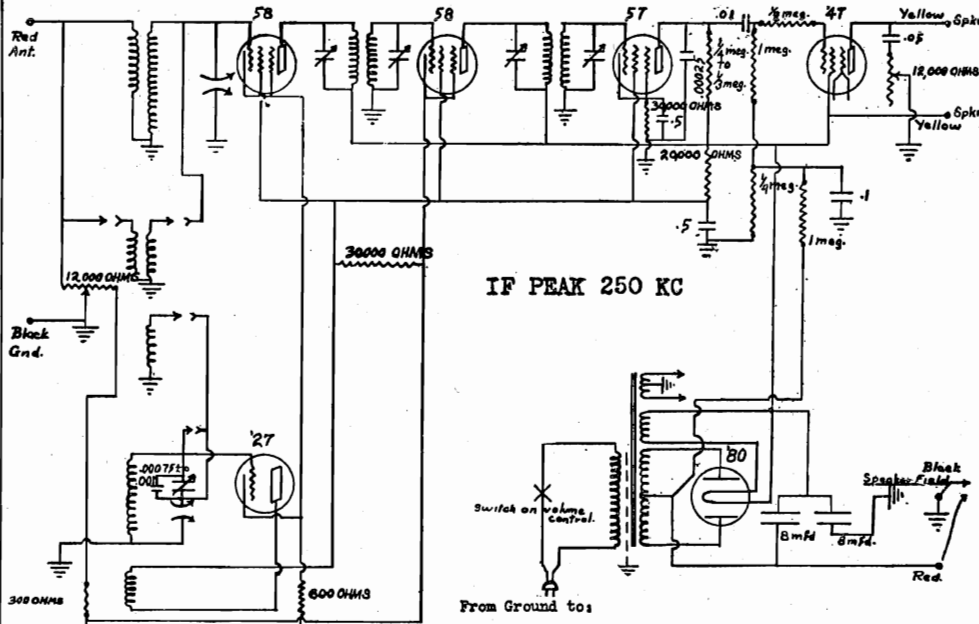

Model 10-3

A.C. Voltages:

Line	--	120 volts
Heater filaments	--	2.3 "
Power tube filament	--	2.3 "
Rectifier filament	--	5.0 "

From Ground to:

#580 Rectifier tube filament	--	235 volts
#547 Power " screen grid	--	235 "
#347 " " plate	--	230 "
#347 " " grid	--	17 "
#58 Mixer " plate	--	235 "
#58 " " screen grid	--	60 "
#58 " " kathode	--	4 "
#58 Intermediate " Plate	--	235 "
#58 " " screen grid	--	60 "
#58 " " kathode	--	2 to 20 volts

#57 Detector Tube plate	--	120 volts
" screen grid	--	60 "
" kathode	--	3 1/2 "
#327 Oscillator Tube plate	--	60 "
" kathode	--	4 "

Due to small current, meter readings will be inaccurate on detector plate and power tube grid.

Speaker field (red lead) -- 105 volts negative.

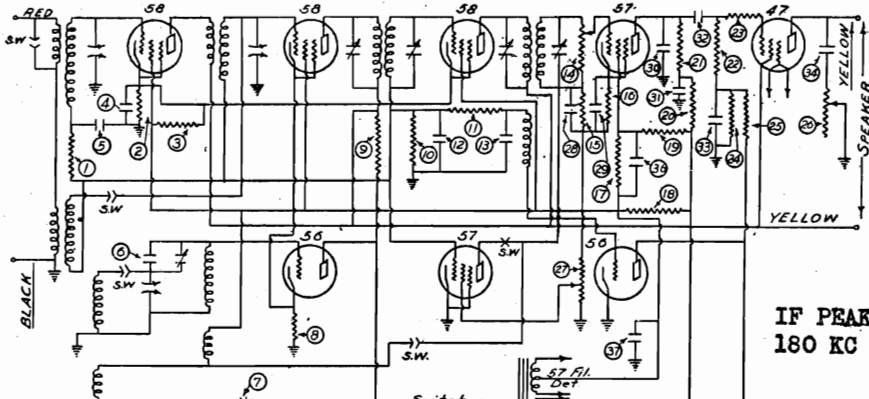

IF PEAK 180 KC

CONDENSER DATA		RESISTOR DATA	
Number	Capacity	Number	Resistor
(4)(7)(33)(34)	.1	(25)(22)	1,000,000
(5)(34)	0.5	(2)	150
(6)(13)	0.01	(3)(10)	25,000
(7)	0.02	(8)	600
(28)(29)(37)	.5	(9)(20)(17)	50,000
(30)	.00025	(11)(15)(1)	100,000
(31)	4 mfd.	(14)(10)(27 var)	500,000
(32)	.02	(13)	20,000
(38)(35)	8 mfd.	(19)(23)(24)(21)	250,000
		(26 var)	12,000

Model 15-3

Voltage readings for servicing purposes follow:

D. C. VOLTAGES FROM GROUND:

#82 Rectifier tube filament	--	260 volts	#56 " " kathode	--	5 "
#47 Power " screen grid	--	260 "	#57 Detector " screen grid	--	110 "
#47 " " plate	--	245 "	#37 " " plate	--	135 "
#47 " " grid	--	18 "	#57 " " kathode	--	90 "
#58 R.F. " screen grid	--	95 "	#57 Noise suppressor " tube plate	--	Var. 0-90
#58 " " plate	--	260 "	#57 " " kathode	--	0
#58 " " kathode	--	2.5 "	#57 " " screen grid	--	Var. 0-90
#58 Mixer " screen grid	--	95 "	VOLTAGES:		
#58 " " plate	--	260 "	Line	--	120
#58 " " kathode	--	5 "	Heater Filaments	--	2.35
#58 Intermediate " screen grid	--	95 "	Power tube filament	--	2.35
#58 " " plate	--	260 "	Detector tube filament	--	2.5
#58 " " kathode	--	2.5 "	Rectifier filament	--	2.5
#56 Oscillator " plate	--	60 "			

Set the LOCAL - DISTANCE switch on DISTANCE and the wave-changing switch on LONG. With the 180 K.C. signal attenuated so low as to be just audible adjust the four controlling trimmers of the I.F. for maximum signal.

The two I.F. transformers and their trimmers are located in the upper right shield cans at the extreme left of the chassis.

To make the dial run true to its kilocycle markings, set the dial at or near 800 K.C. using an oscillator or a Broadcasting Station of known frequency. By tuning to an oscillator or station at or near 550 K.C. the dial may now be made to "track" by adjusting the radio set's oscillator series padding condenser. This is located next to the oscillator tube socket beneath the chassis. It must be adjusted thru the hole in the chassis between the oscillator tube and the variable tuning condenser.

MODEL PABC-2
 MODEL PABC-3
 MODEL PAM-5

SAMSON ELECTRIC CO.

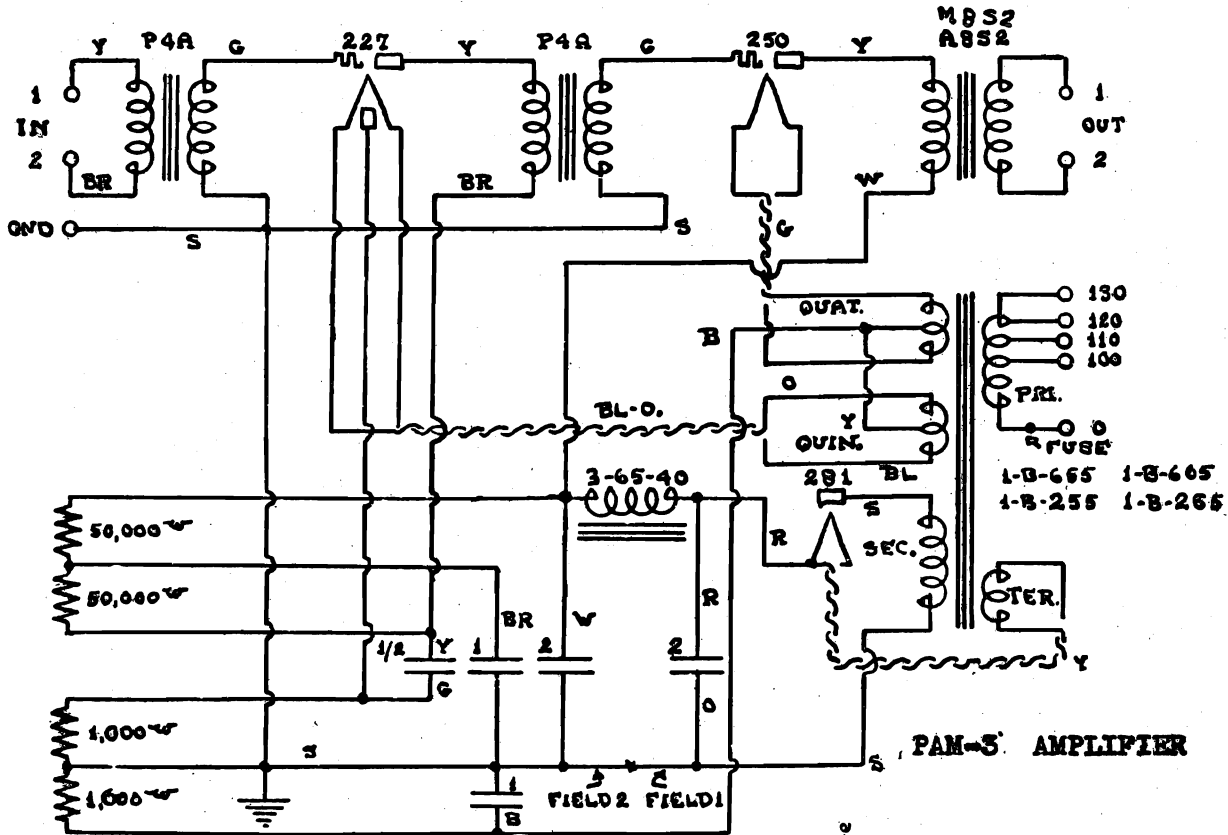

PAM-5 AMPLIFIER

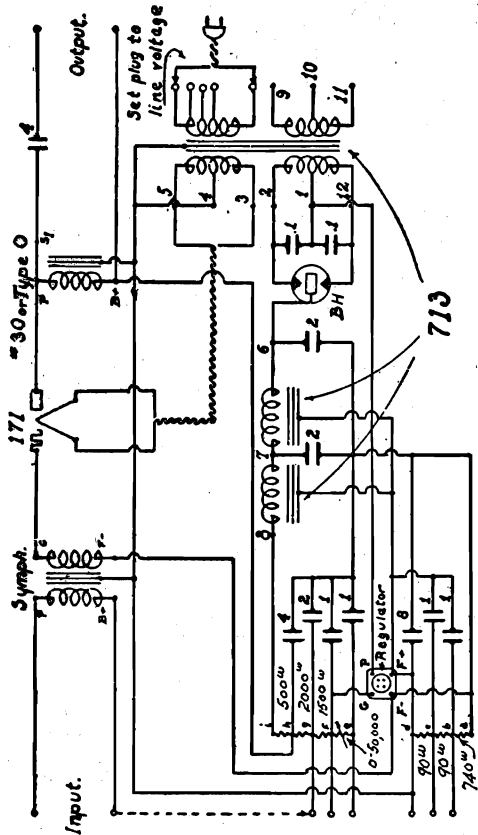

PABC-2 Schematic.

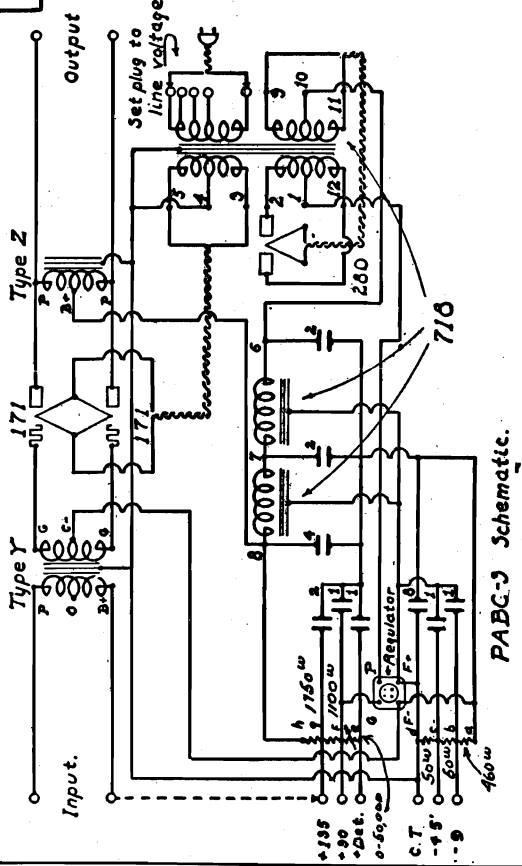

PABC-3 Schematic.

MODEL PAM-5
MODEL PAM-5-D

SAMSON ELECTRIC CO.

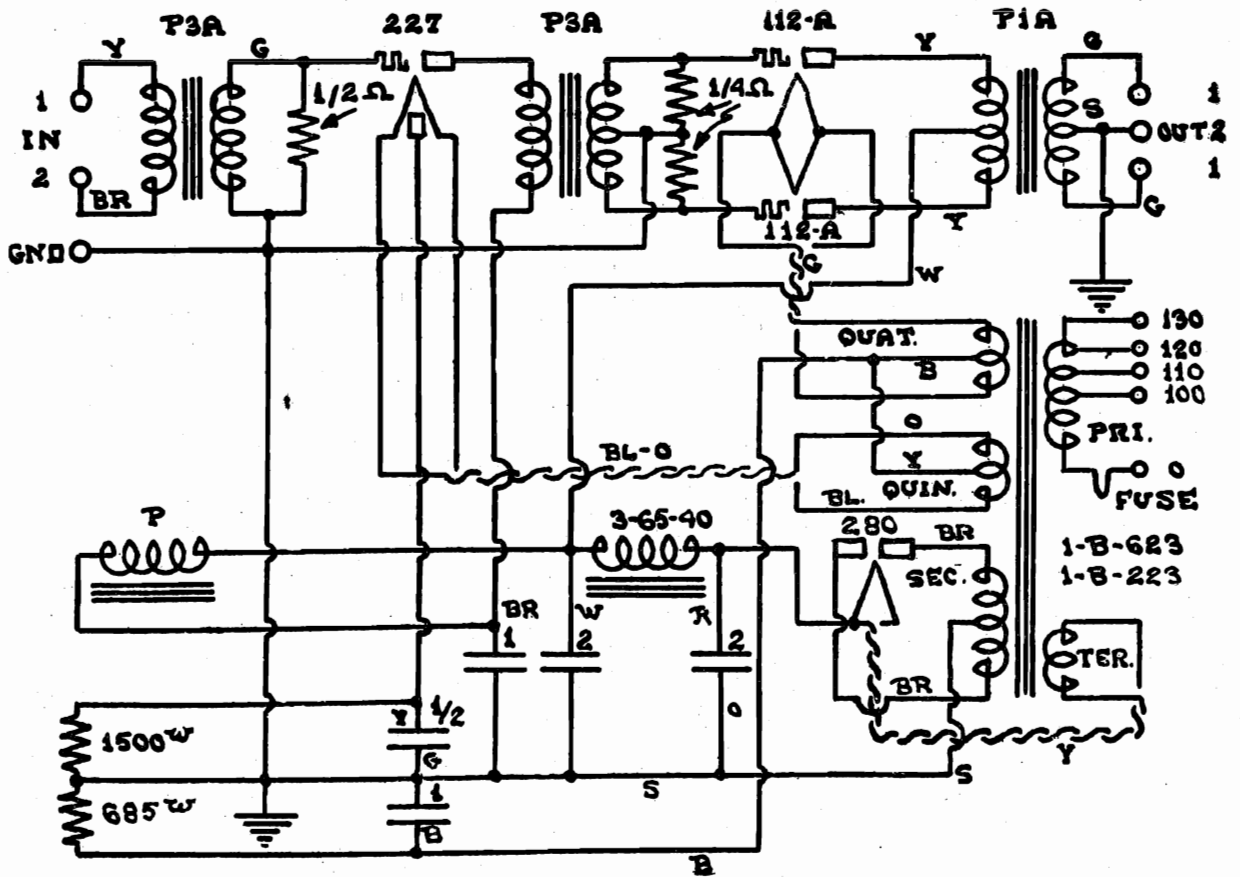

PAM-5 AMPLIFIER

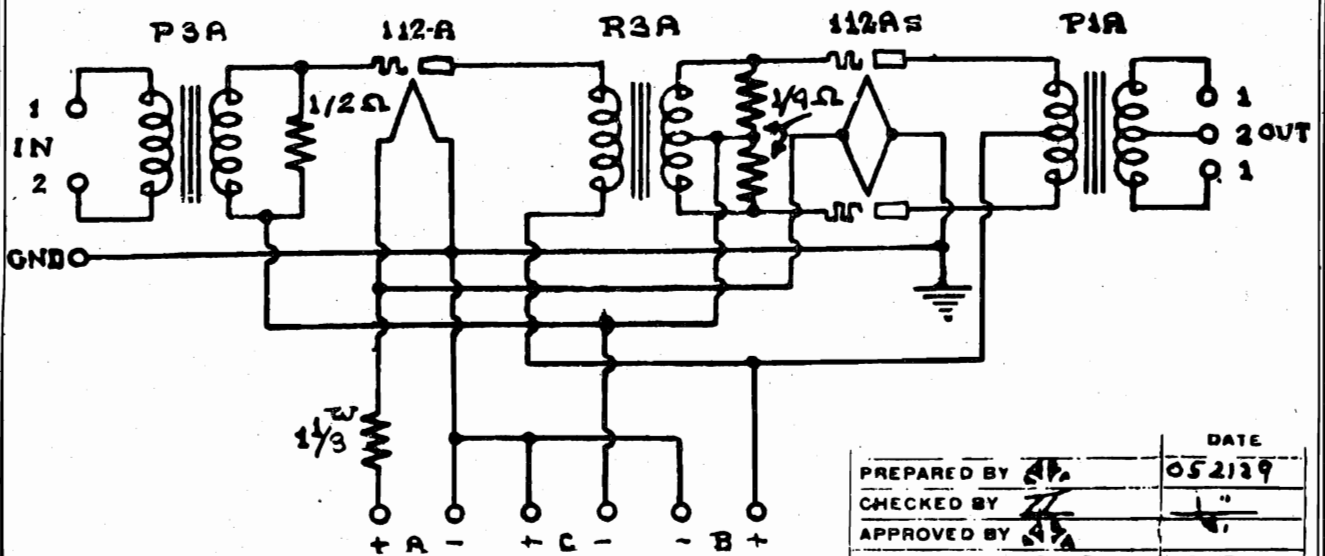

PAM-5-D AMPLIFIER

		DATE
PREPARED BY	AP	052139
CHECKED BY	Z	
APPROVED BY	AP	
FORM BY	G.W.B.	120529

SAMSON ELECTRIC CO.

MODEL PAM-19-N
MODEL PAM-19-Q

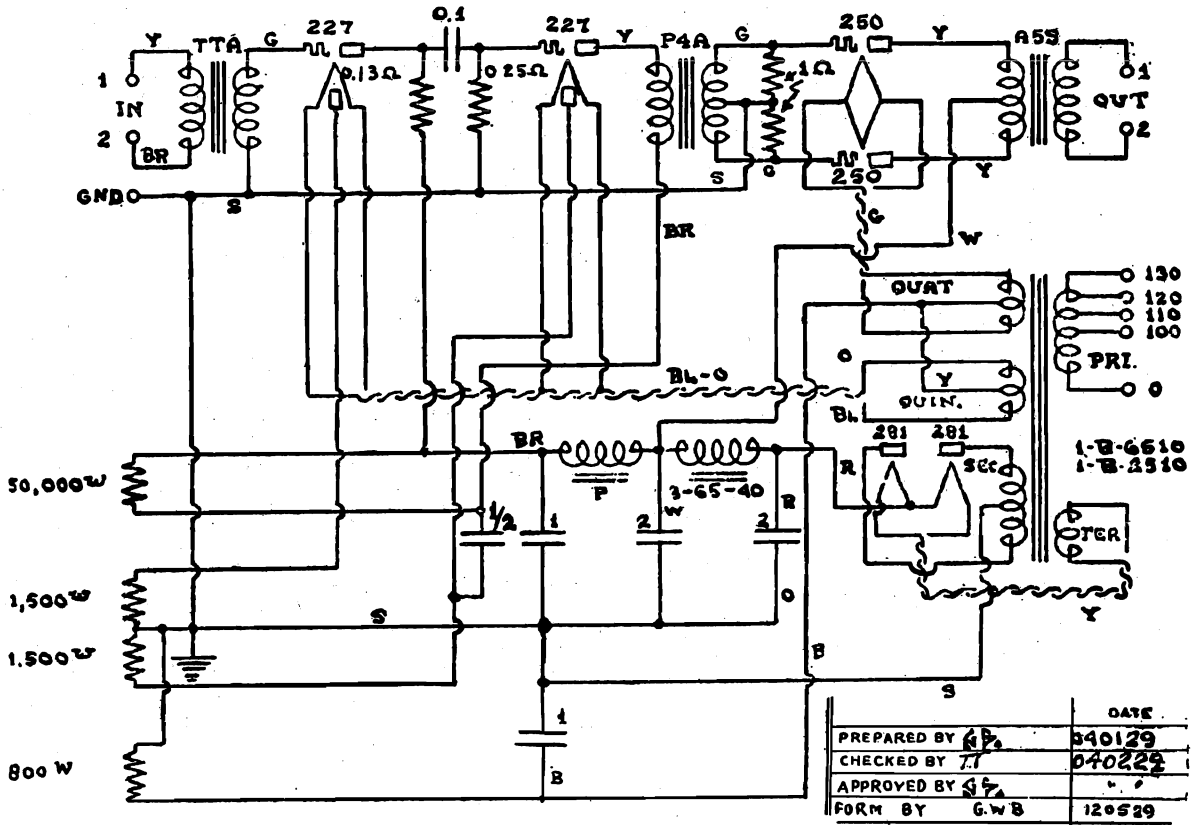

PAM-19-N AMPLIFIER

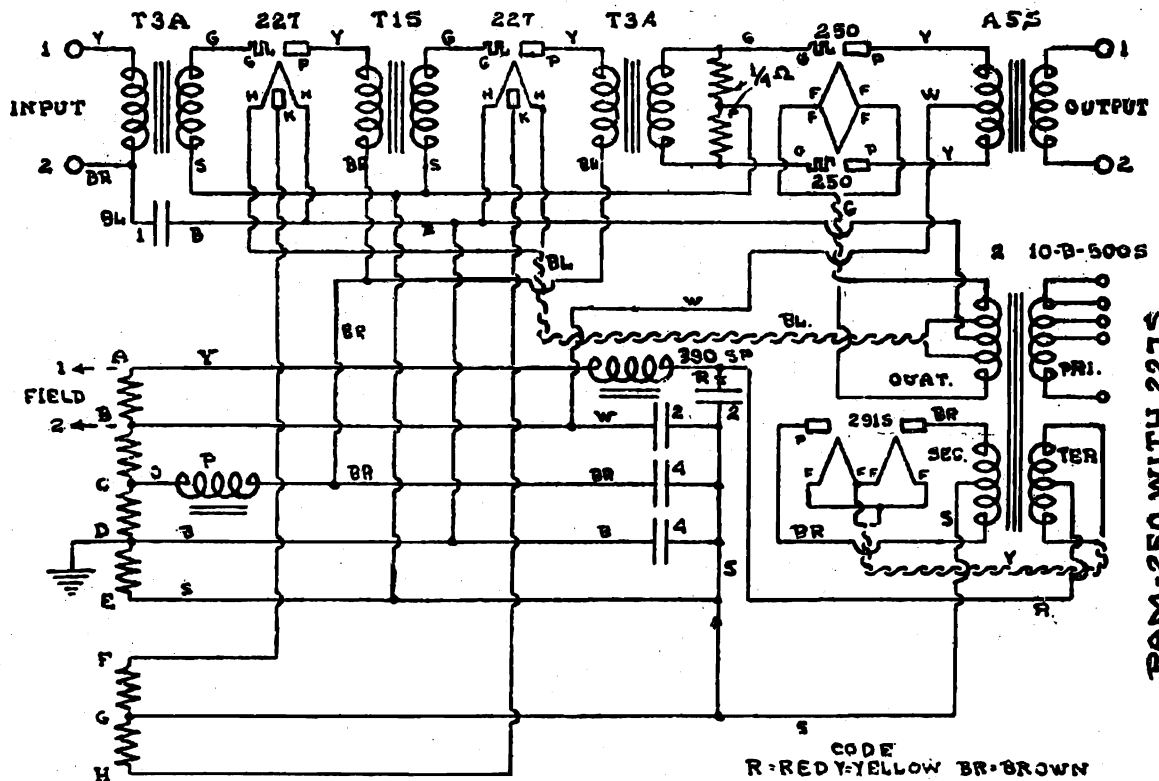

PAM-250 WITH 227S
PAM-19-Q AMPLIFIER

PREPARED BY	DATE
CHECKED BY	093028
APPROVED BY	"
	093028

CODE
R-RED Y-YELLOW BR-BROWN
W-WHITE BL-BLUE G-GREEN
O-ORANGE B-BLACK S-SLATE
THE SMALL LETTERS NEAR TUBES
DESIGNATE SOCKET TERMINALS.
SEE OTHER PRINTS FOR DETAILS.

MODEL PAM-22

SAMSON ELECTRIC CO.

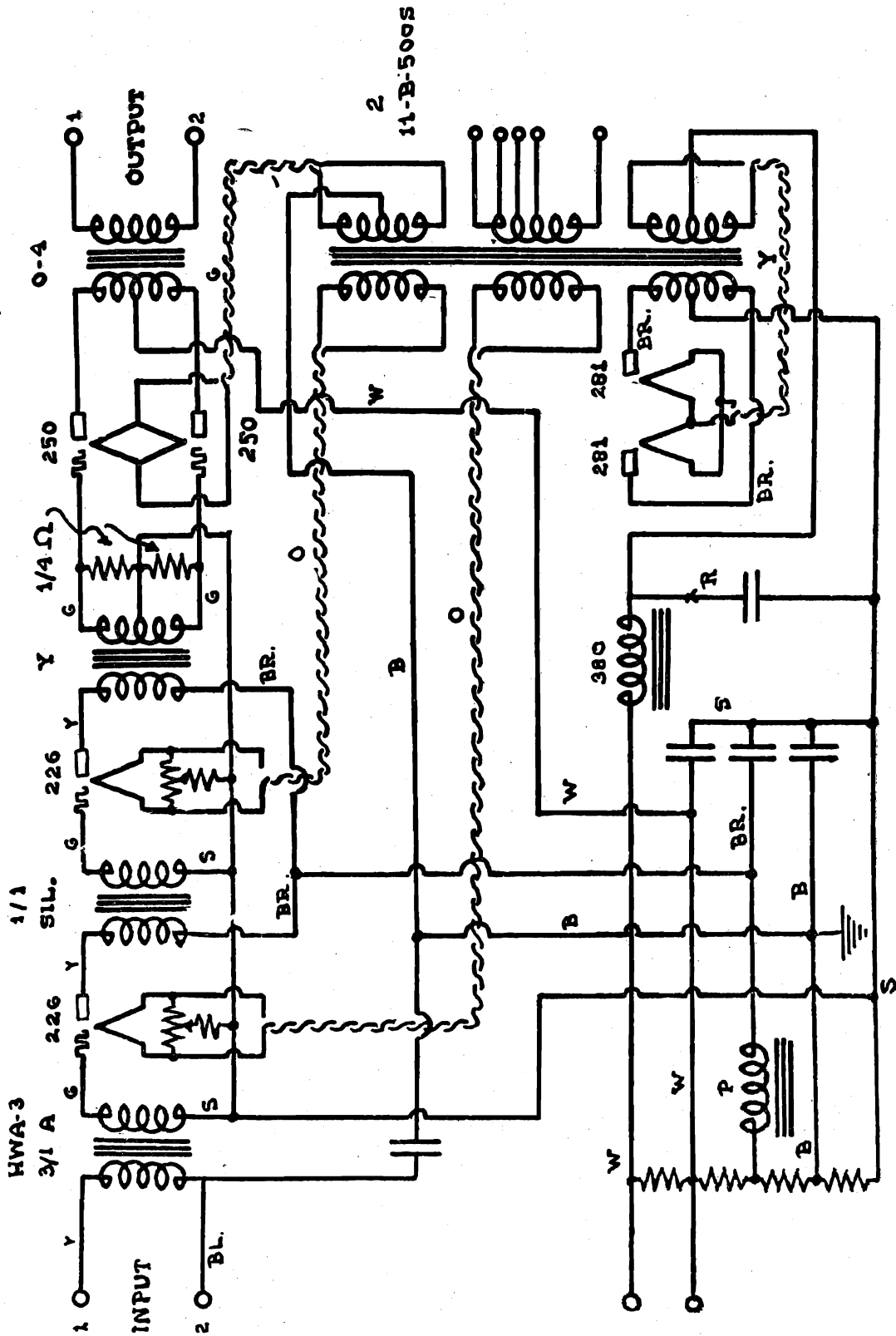

DATE	PREPARED BY	CHECKED BY	APPROVED BY
091428	SB	7.7	SB
09/4/28			
091428			

PAM-22 AMPLIFIER

SAMSON ELECTRIC CO.

MODEL PAM-23
 MODEL PAM-24
 MODEL PAM-25
 MODEL PAM-25-D

PAM-23, 24, 25 & 25-D AMPLIFIERS

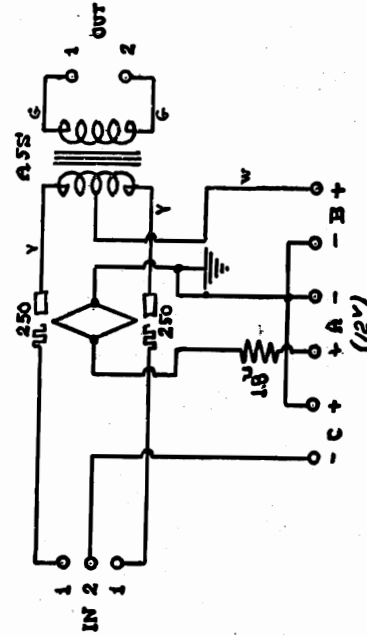
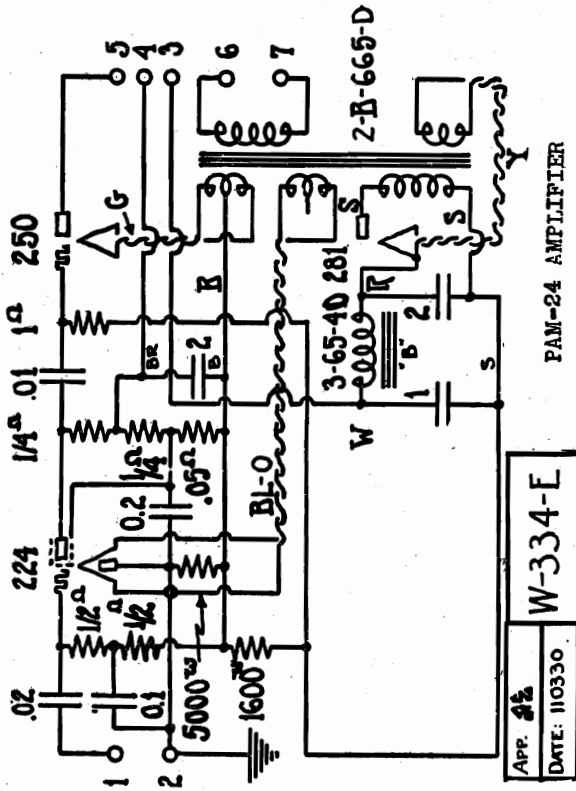

PREPARED BY	DATE	REVISIONS
45	05-21-29	A
45	05-21-29	B
45	05-21-29	C
45	08-19-29	D

PAM-25-D AMPLIFIER

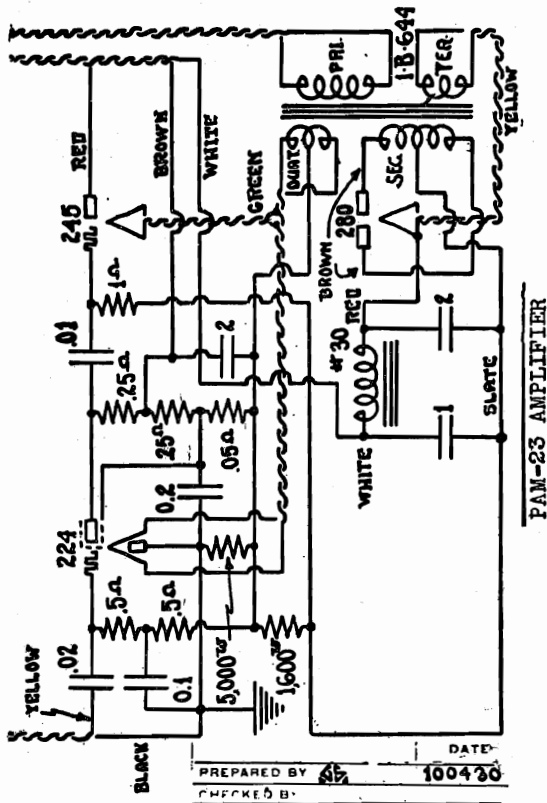

PAM-23 AMPLIFIER

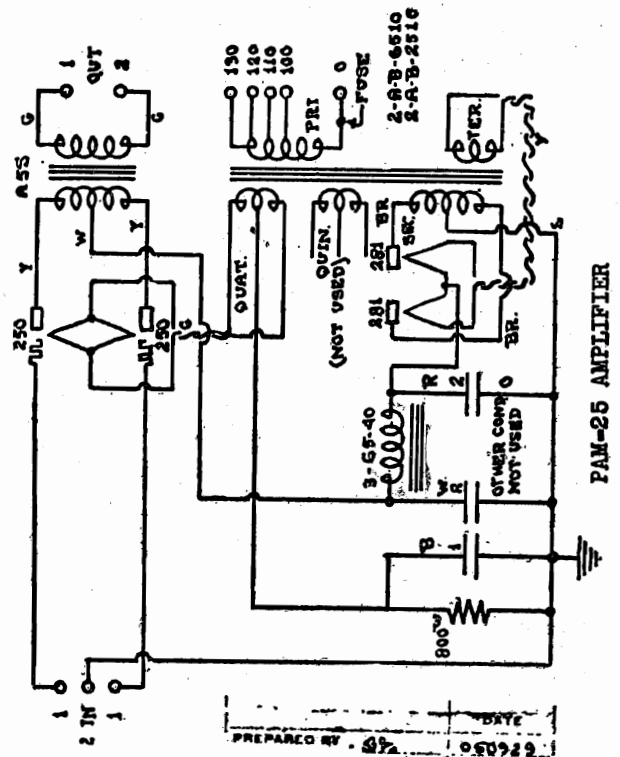

PAM-25 AMPLIFIER

DATE: 100430
 PREPARED BY: 45
 CHECKED BY:

DATE: 050929
 PREPARED BY: 45

SAMSON ELECTRIC CO.

MODEL PAM-45
MODEL PAM-48

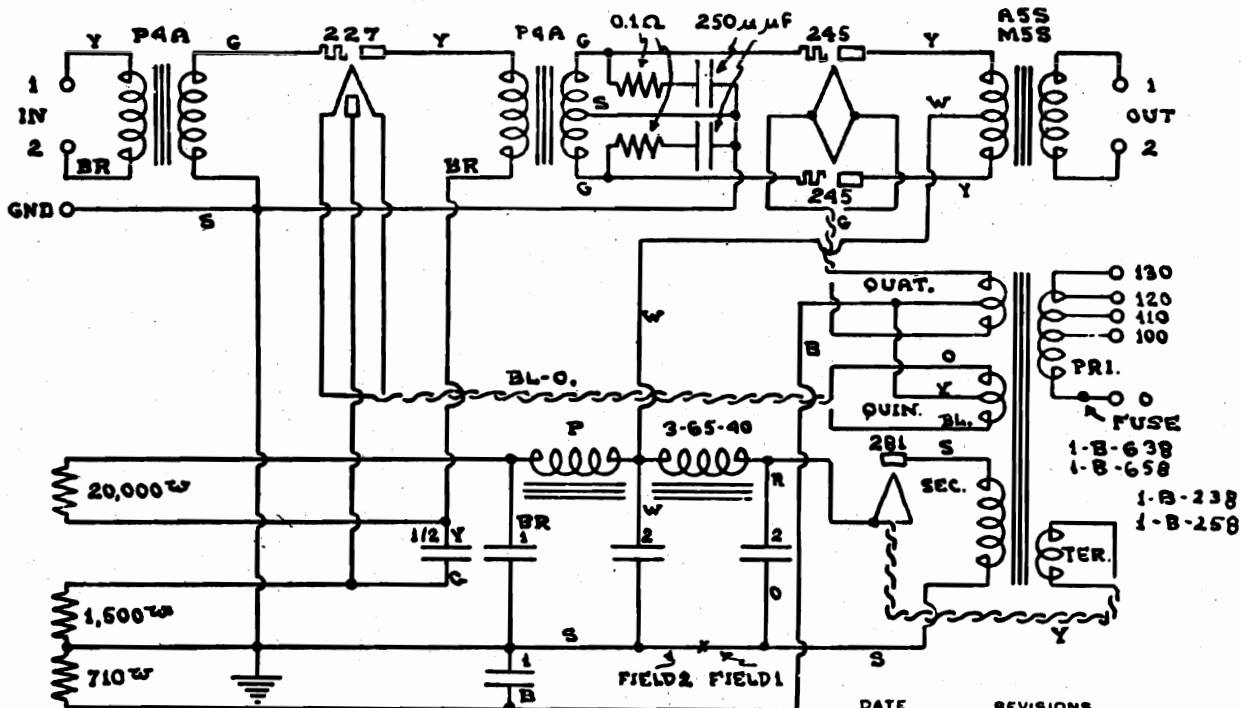

PAM-45 AMPLIFIER

	DATE	REVISIONS
PREPARED BY <i>SP</i>	060929	A
CHECKED BY <i>TT</i>	"	B
APPROVED BY <i>SP</i>	"	C
FORM BY G.W.B.	120529	D

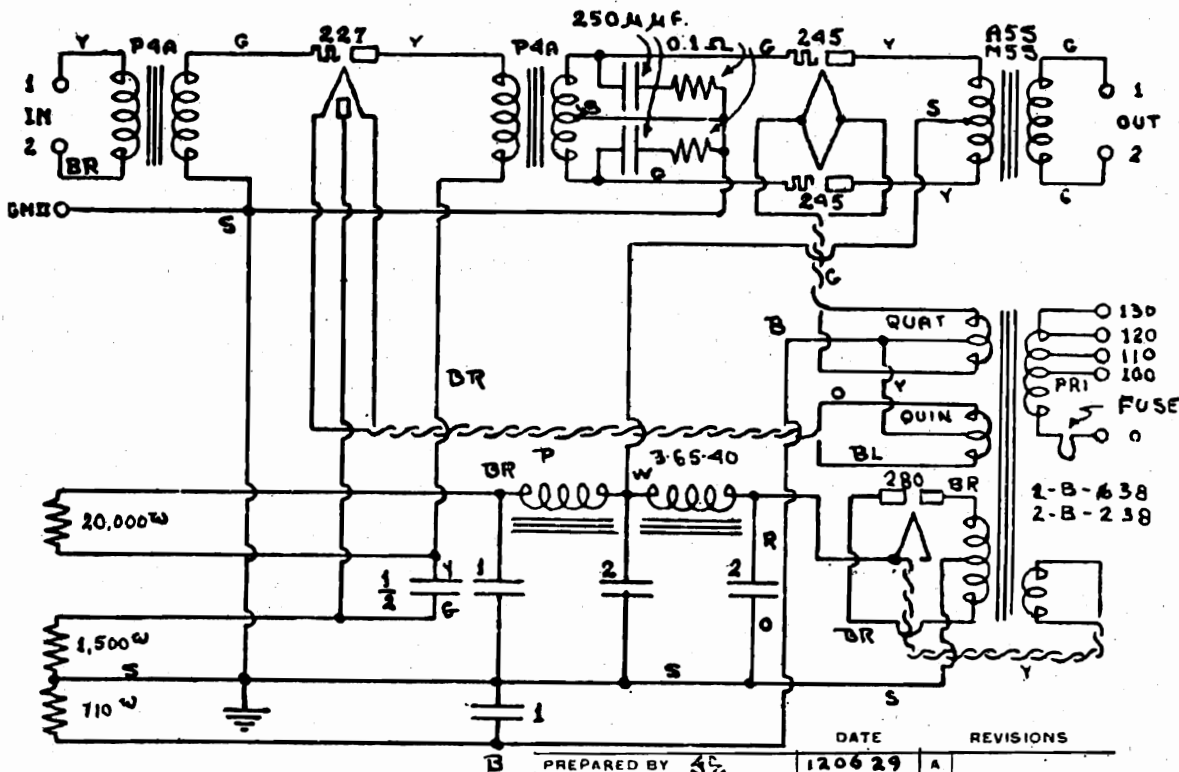

PAM-48 AMPLIFIER

	DATE	REVISIONS
PREPARED BY <i>SP</i>	120629	A
CHECKED BY G.W.B.	120729	B
APPROVED BY <i>SP</i>	"	C
FORM BY <i>SP</i>	021429	D

SAMSON ELECTRIC CO.

MODEL MIK-80
MODEL PAM-80

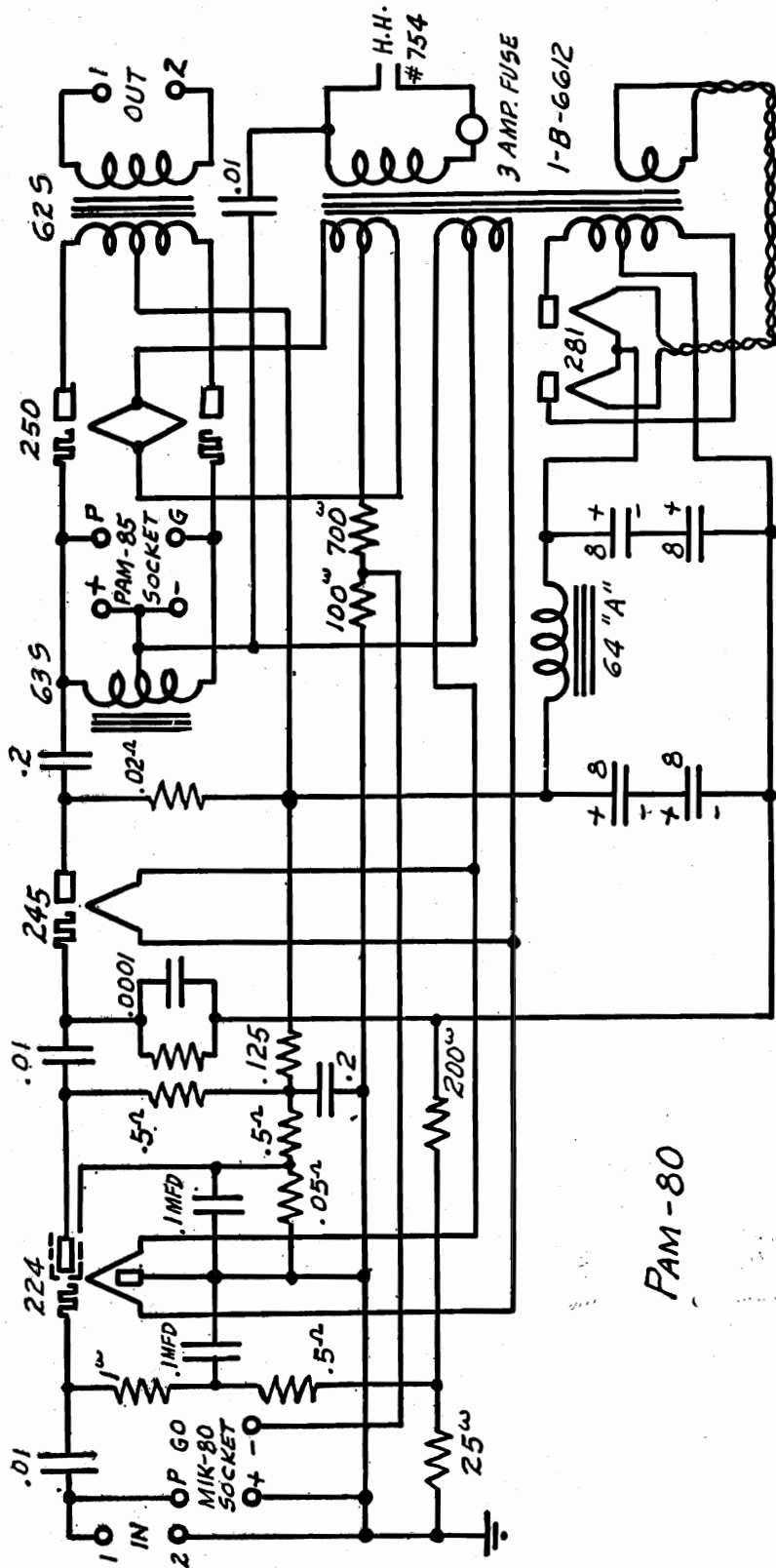

PAM-80

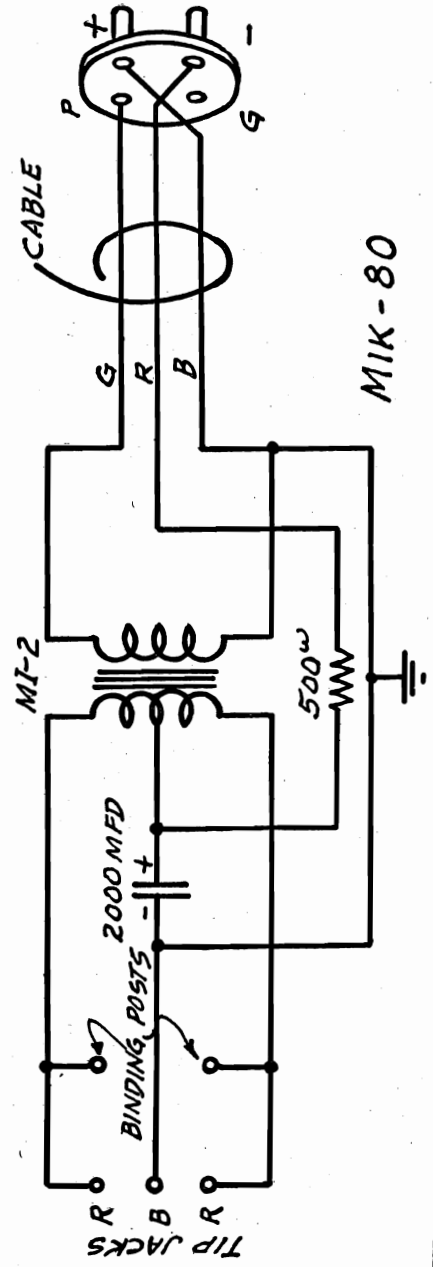

MIK-80

SCOTT TRANSFORMER CO.

MODEL "World Record" 10
MODEL Shield Grid "9"

Model World Record 10

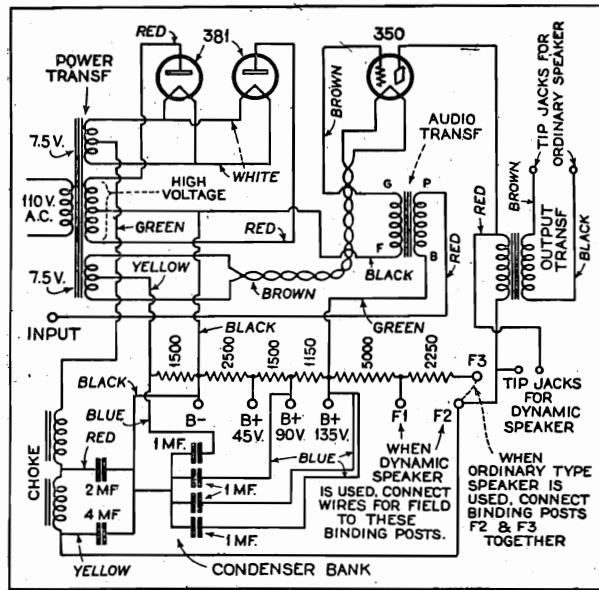
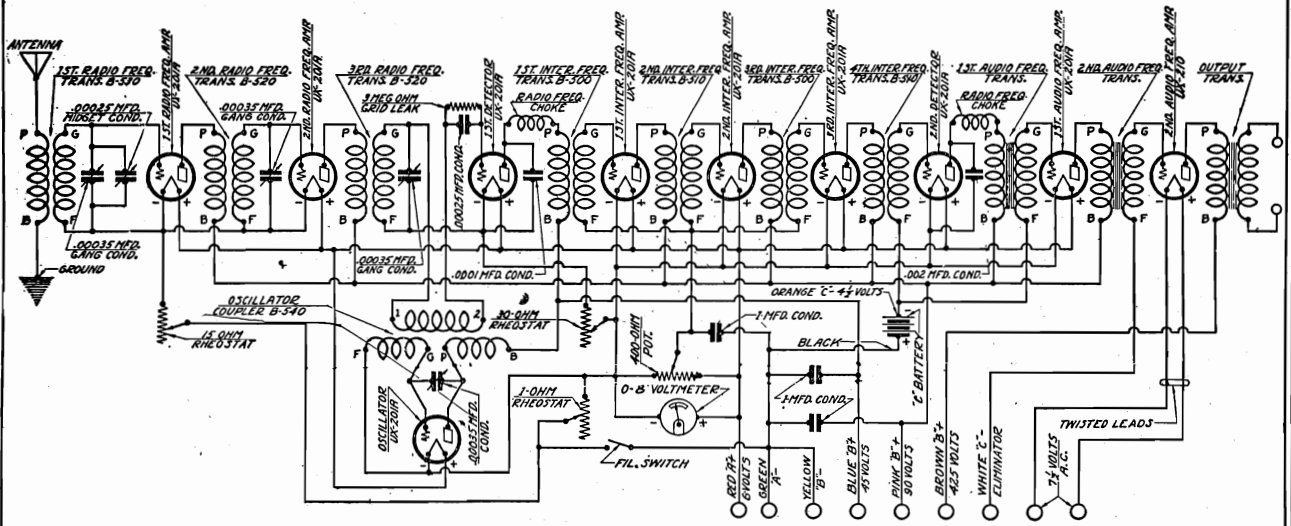

Model Shield Grid 9
Power Pack

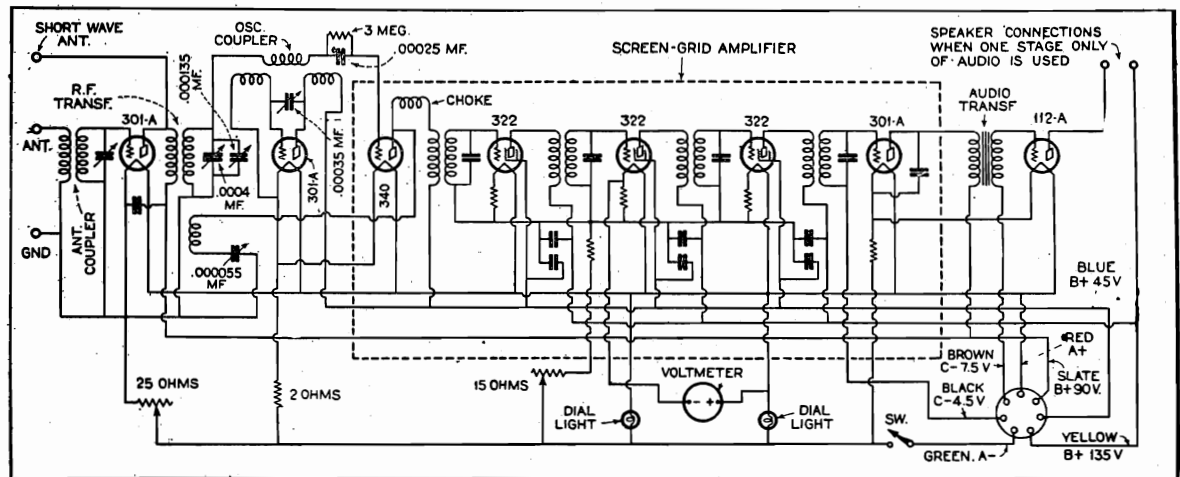

Model Shield Grid 9 Receiver Schematic

MODEL "All Wave" Super, SCOTT TRANSFORMER CO.,
Receiver Chassis

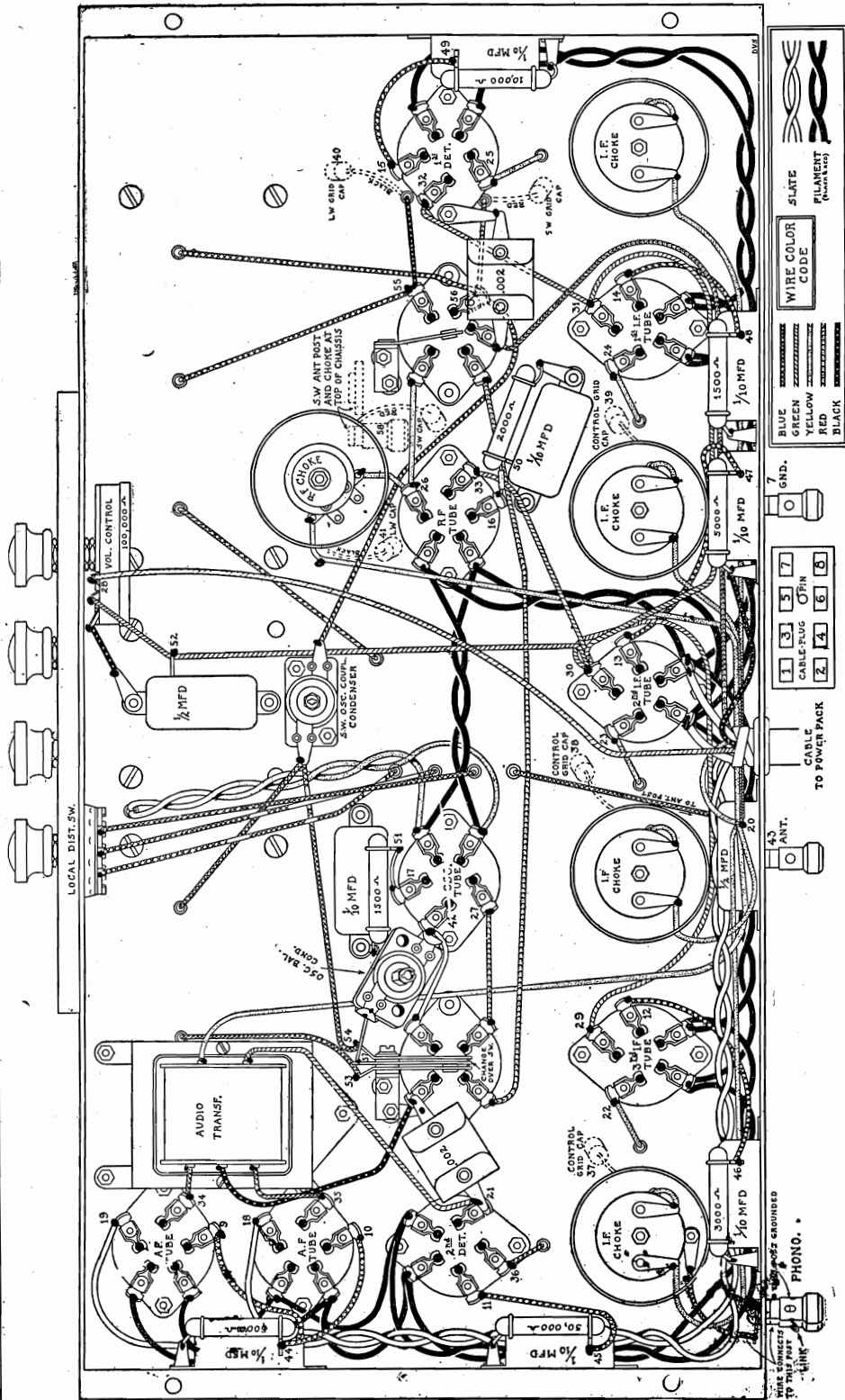

HOW TO DISTINGUISH OSCILLATOR FROM R. F. COIL

- | | |
|--|--|
| <p>Oscillator Coil</p> <ul style="list-style-type: none"> Two Enamel Wire Windings Two Enamel Wire Windings Two Enamel Wire Windings Two Enamel Wire Windings Two Enamel Wire Windings | <p>R. F. Coil</p> <ul style="list-style-type: none"> One Enamel Wire Winding One Enamel Wire Winding One Enamel Wire Winding One Enamel, One Silk Winding One Enamel, One Silk Winding |
|--|--|
- NOTE:**—When tuning short wave stations the short wave coils must be left exposed (the aluminum covers should not be replaced). Be sure that both oscillator and R. F. coils are for the same wave length band: The tube on the extreme right of the chassis is the first detector

SCOTT TRANSFORMER CO. MODEL "All Wave" Super Receiver Schematic

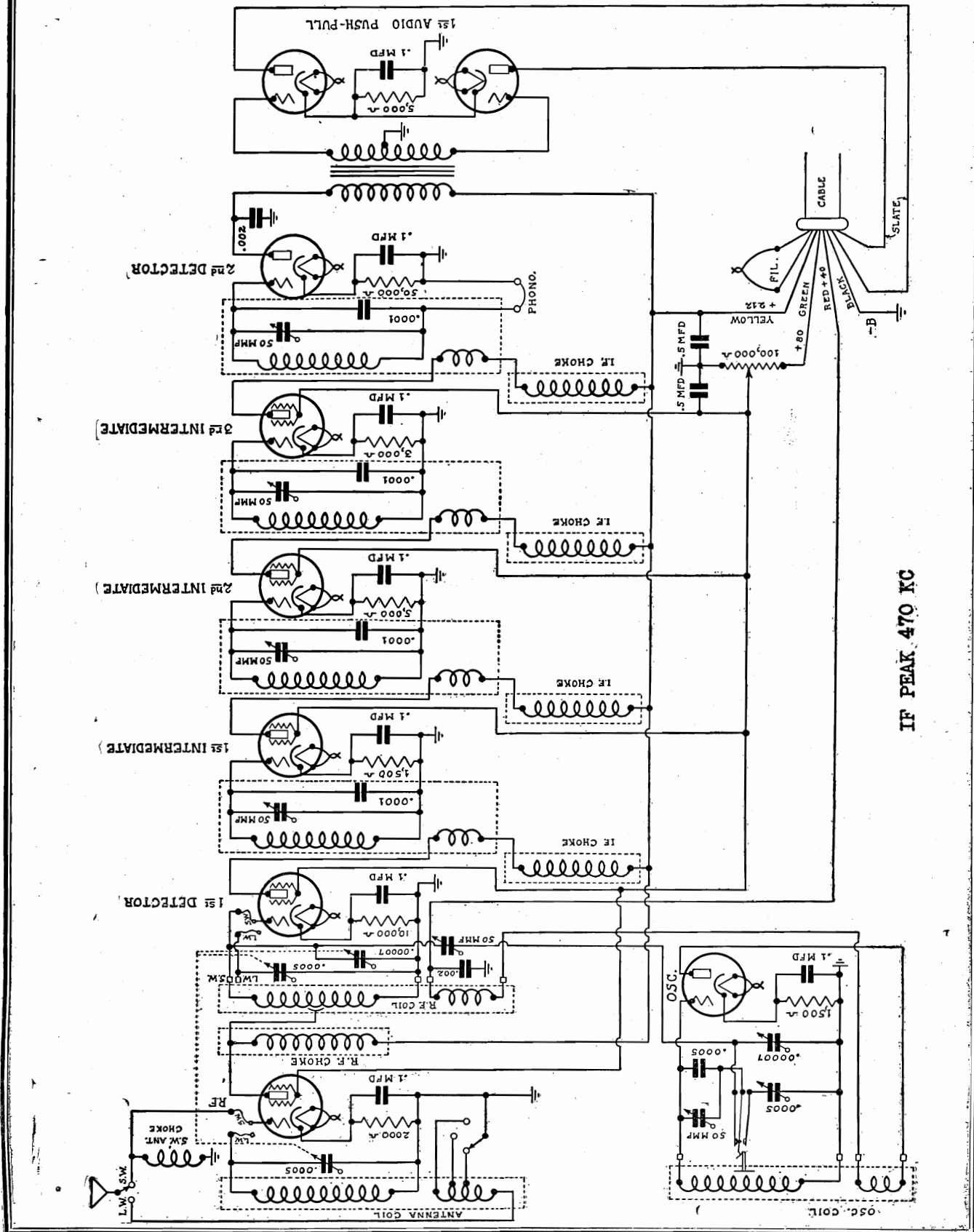

IF PEAK 470 KC

SCOTT TRANSFORMER CO.

MODEL "All Wave" Super
145 Power Pack
Schematic- Chassis

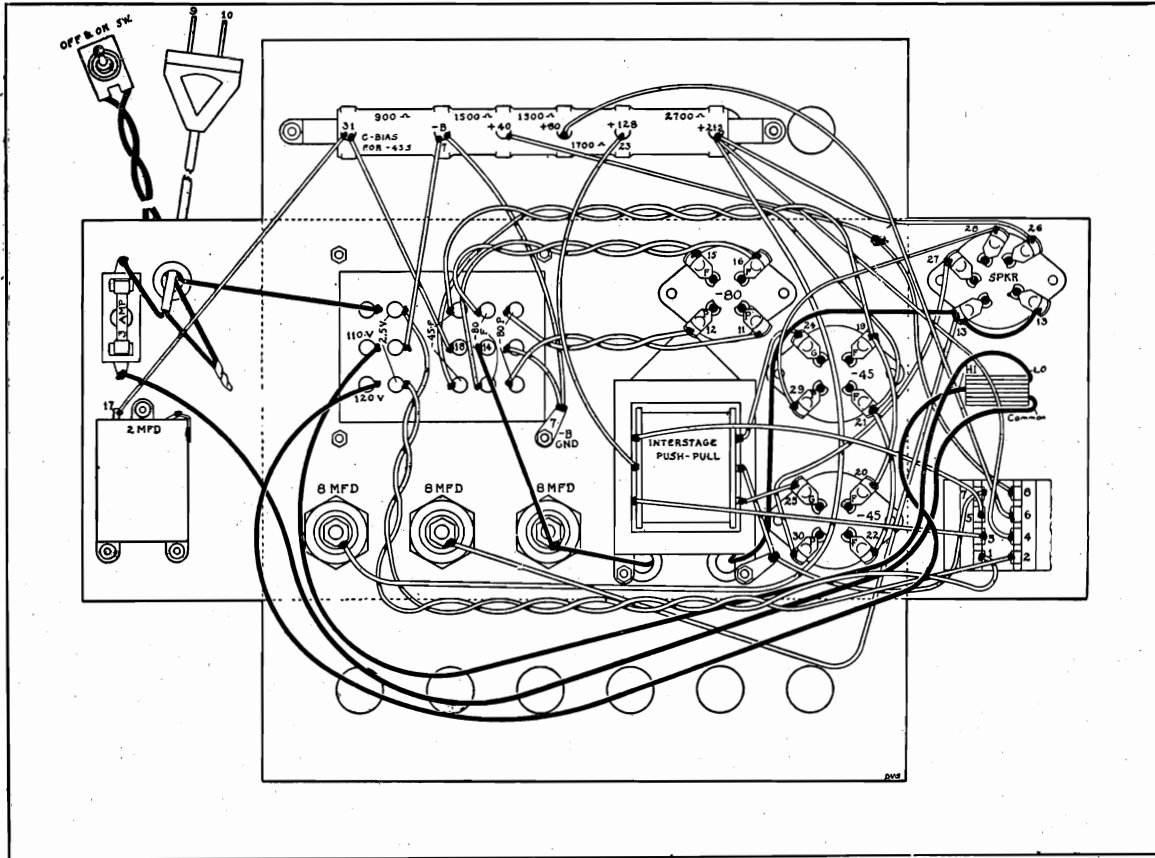

Wiring Diagram of 145 Power Pack

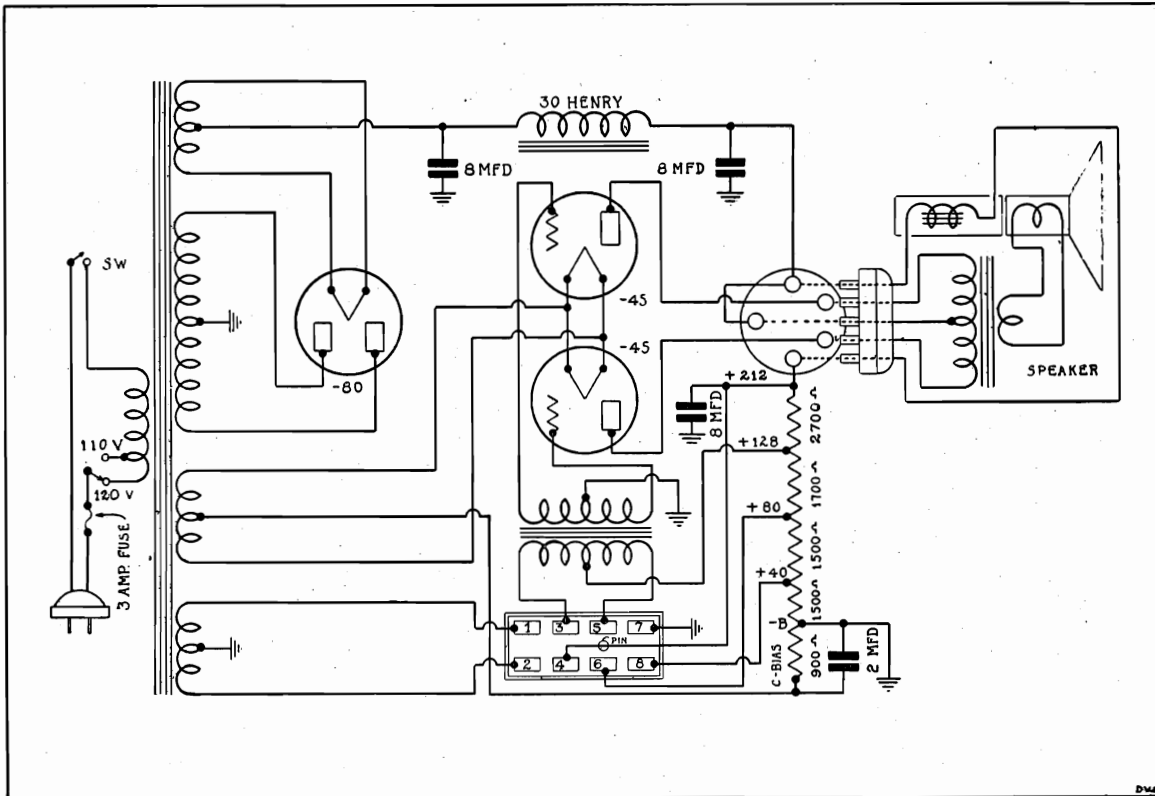

Schematic Diagram of 145 Power Pack

MODEL 1150

Voltage-Data

SEARS-ROEBUCK & CO.

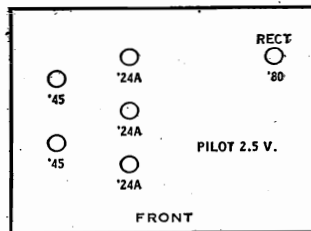

60 cycle	Line 115 V.	RF1	RF2	Det.	245#1	2452	280AC	280DC
Plate Voltage D.C.		250	250	235	250	250	330	300
Screen Voltage D.C.		85	85	85				
Heater Voltage A.C.		2.45	2.45	2.45	2.4	2.4	(4.7)	
Control Grid Voltage D.C.		3	3	8	50			
Speaker Field Voltage	300							
Total Rectifier Current	.090							

25 cycle	Line 115 V.	RF1	RF2	Det.	245#1	245#2	280AC	280DC
Plate Voltage D.C.		230	230	215	230	230	315	270
Screen Voltage D.C.		75	75	75				
Heater Voltage A.C.		2.3	2.3	2.3	2.3	2.3	4.85	
Control Grid Voltage D.C.		2.8	2.8	7.5		45	45	
Speaker Field Voltage	270							
Total Rectifier Current	.090							

Control grid volts of the R.F. tubes and detector are measured from Cathode to Ground. 245 Grid volts Filament to Ground.

CIRCUIT DATA - The 25 cycle models are identical electrically with the 60 cycle models except for power transformer, filter condensers and omission of hum balance potentiometer. Characteristics are the same as the 60 cycle models. Voltages are slightly lower and there is a difference in the arrangement of parts. The volume control used on these receivers operates by varying the coupling between the primary and secondary on the antenna and R.F. stages. This variation in coupling is effected by moving the primary coils. The antenna and R.F. primaries are also moved by the rotation of the tuning condenser to maintain uniform sensitivity over the broadcast band. The detector primary is not moved to control volume but is moved by rotation of the tuning condenser. This system of volume control does not change the voltages or currents in the tubes. The new variable- μ , screen grid tube, -35, may be used interchangeably with the -24 in the R.F. stages only.

OSCILLATION - Oscillation in receivers employing the variable coupling volume control may be caused by (A) Leads to the movable primary coils too close together, causing interstage coupling. The pairs of leads should be spaced at least 1-1/4 inches apart throughout their length. (B) Movable primaries in wrong position. When the dial is set at 55, and the volume control set at maximum, the primaries should be at the position of maximum coupling. The U-brackets carrying the coils should have about 1/32 clearance from the plate which supports the RF coils. When the volume control is left at maximum and the dial turned to move the condenser to the higher frequency settings, the coils should remain approximately in line, the RF coils moving out slightly more than the detector primary. Adjustment may be made by moving stop collar on rear end of volume control shaft.

SEARS-ROEBUCK & CO.

MODEL 1250
MODEL 1152,1420
Schematics

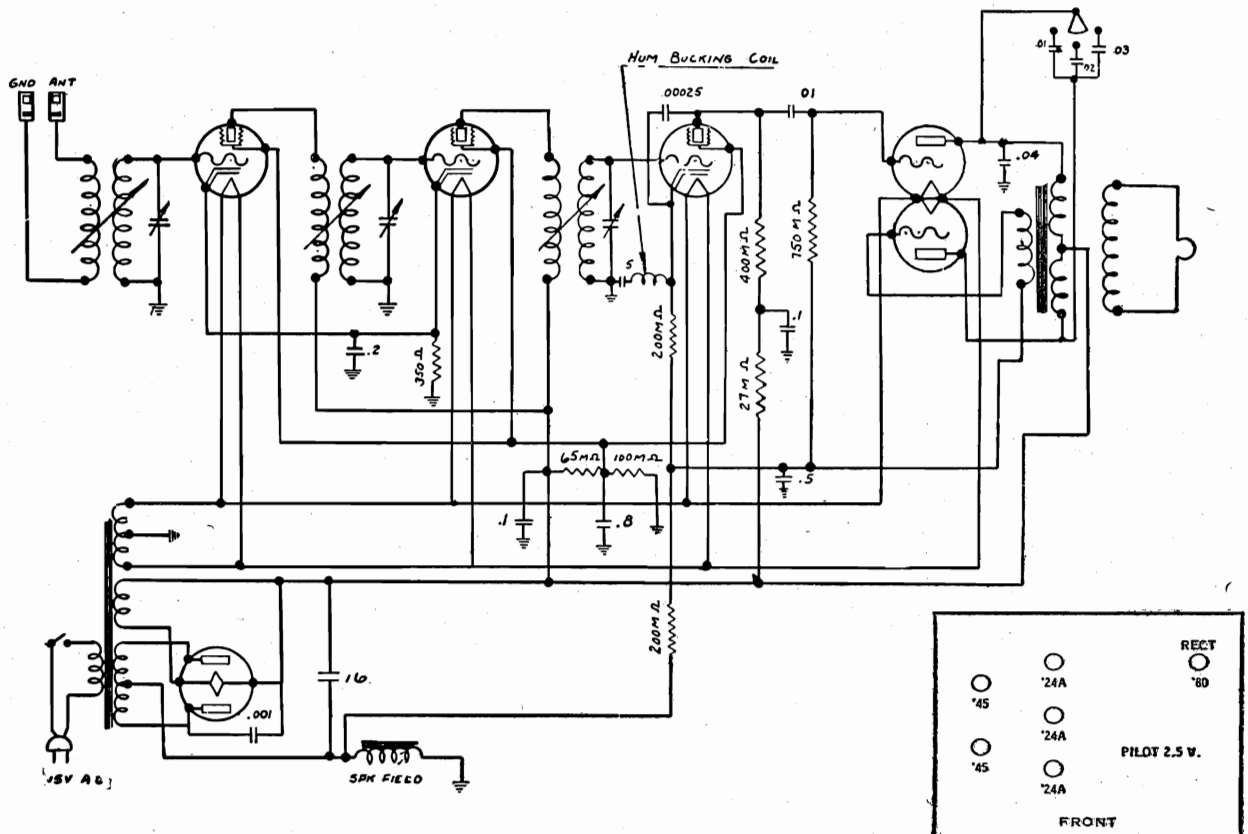
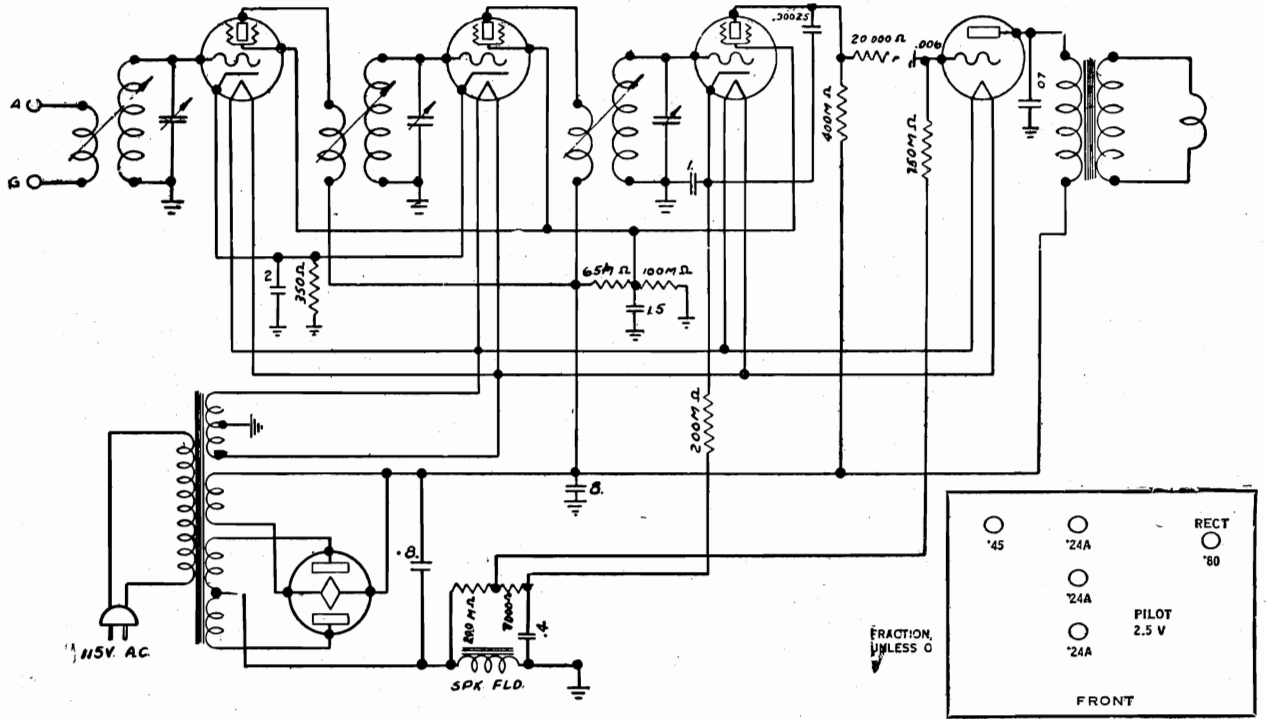

SEARS-ROEBUCK & CO.

MODEL 1252
Chassis-Voltage

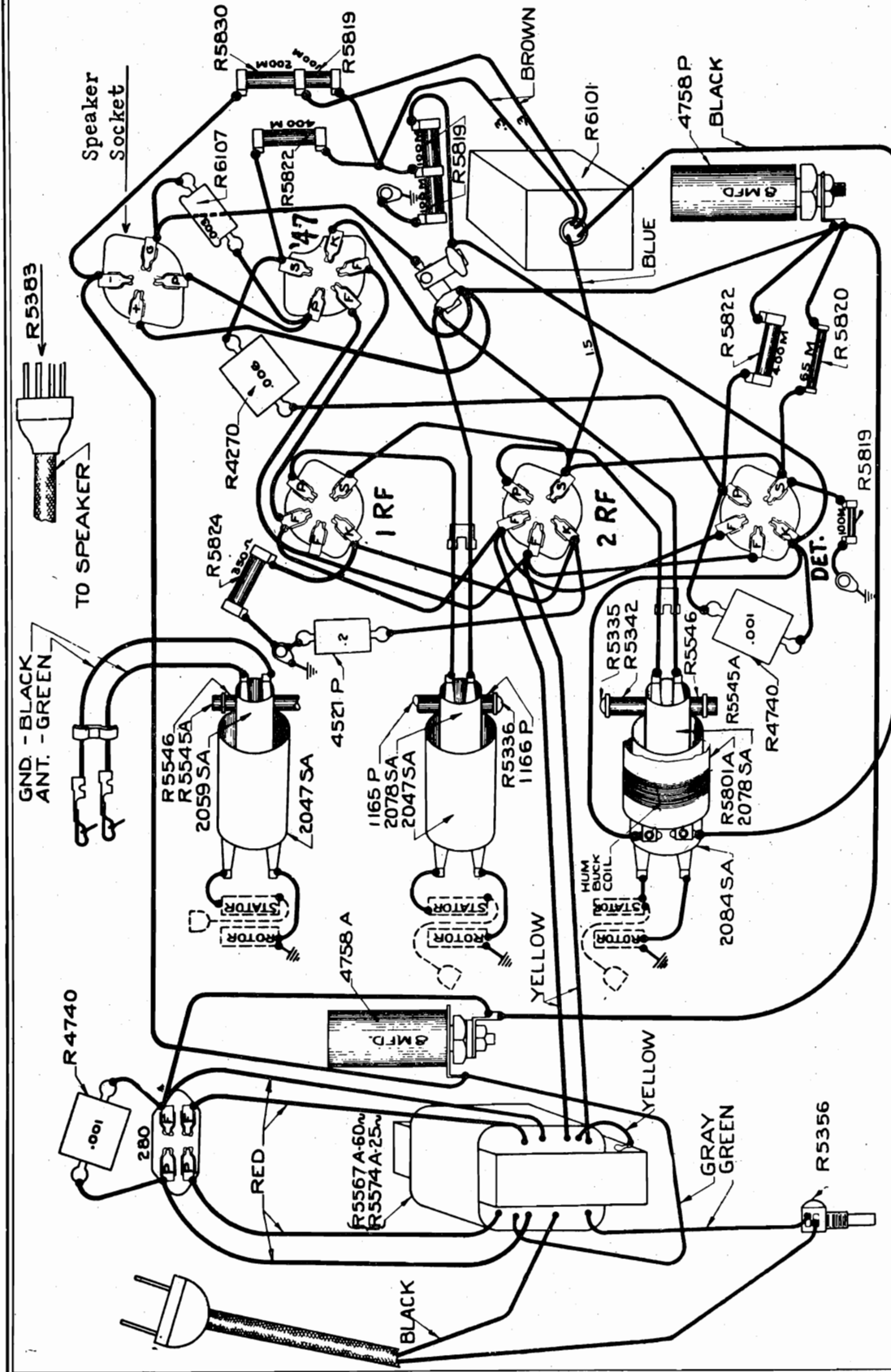

60 Cycle		25 Cycle	
RF1	RF2	Det.	247
220	220	100	210
70	70	70	340
2.3	2.3	2.3	4.8
2.4	2.4	7	15
Line Voltage 115			
Control Grid Volts are measured from Cathode to Ground or Filament.			
Total Rectifier Current .045			
Speaker Field Voltage 100			
Control Grid Voltage D.C. 100			
Heater Voltage A.C. 4.8			
Screen Voltage D.C. 320			
Plate Voltage D.C. 340			
RF1	RF2	Det. <td>247</td>	247
240	240	100	230
70	70	70	335
2.4	2.4	2.4	5
2.3	2.3	7	15
Line Voltage 115			
Control Grid Volts are measured from Cathode to Ground or Filament.			
Total Rectifier Current .045			
Speaker Field Voltage 100			
Control Grid Voltage D.C. 100			
Heater Voltage A.C. 2.4			
Screen Voltage D.C. 230			
Plate Voltage D.C. 340			

SEARS-ROEBUCK & CO.

MODEL 1290,1300
MODEL 1292,1302
Chassis

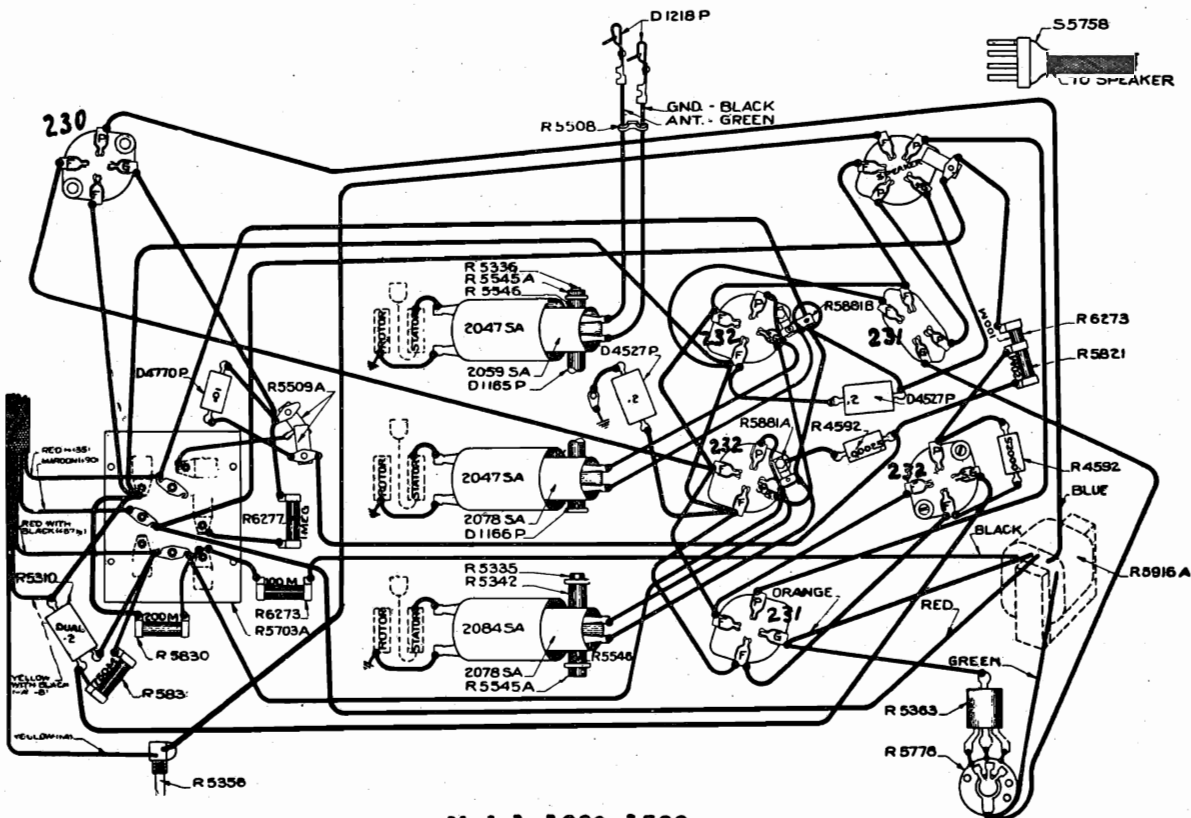

Model 1290,1300

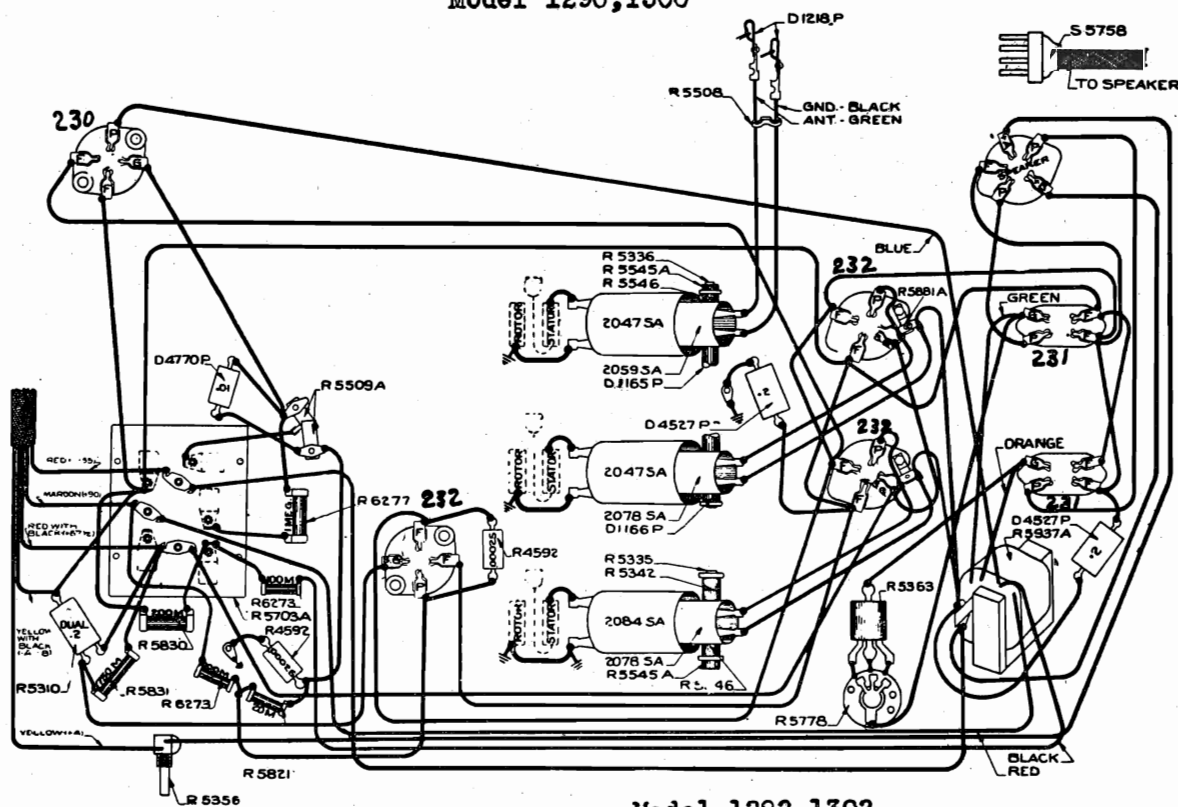

Model 1292,1302

MODEL 1290,1300
 MODEL 1292,1302
 Schematic

SEARS-ROEBUCK & CO.

Model 40	RF1	RF2	Det.	1st Audio	231
Plate Voltage D.C.	135	135	80	90	130
Screen Voltage D.C.	67	67	25		
Filament Voltage D.C.	2.0	2.0	2.0	2.0	2.0
Control Grid Voltage D.C.	3	3		4.5	22.5

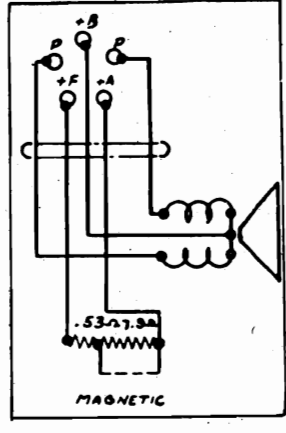
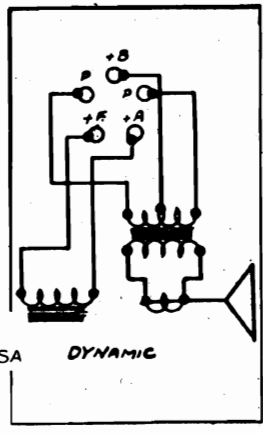
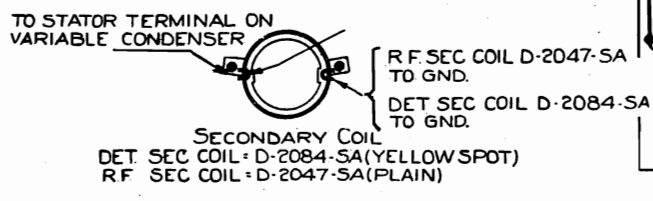
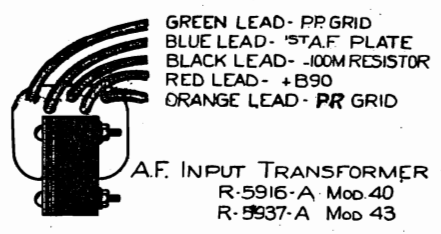
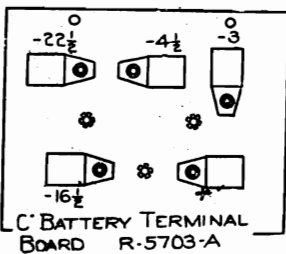
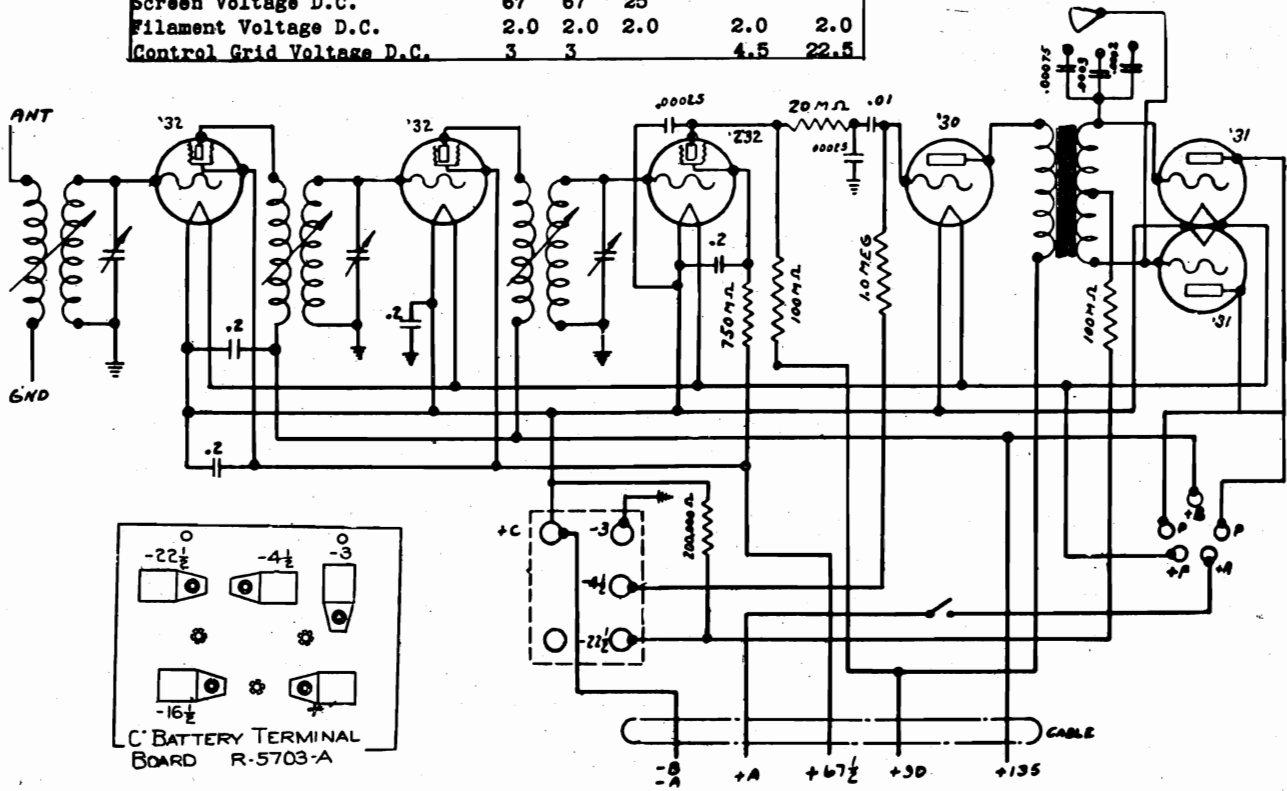

1290,1300

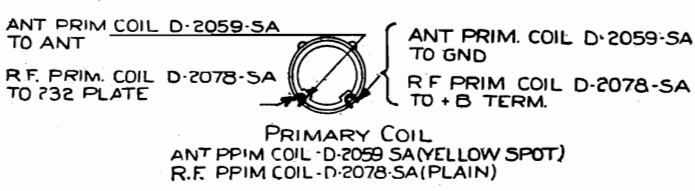
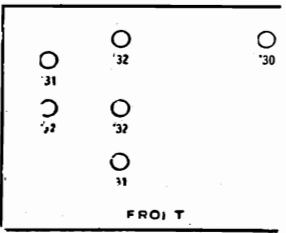

1292,1302

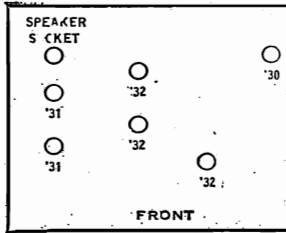

SEARS-ROEBUCK & CO.

MODEL 1320,1322,1324

MODEL 1450

Schematics

60 Cycle Total Watts	- 80							
Line Voltage - 115	Tran.	Osc.	I.F.	R.F.	Det.	2-247	280AC	280DC
Plate Voltage DC	230	40	240	240	160	235	240	350
Screen Voltage DC	65		65	65	20	240		
Heater Voltage AC	2.44	2.44	2.44	2.44	2.44	2.45	4.85	
Control Grid Voltage DC	10		1.7-40	1.7-40	20	16		
Speaker Field Voltage	110 Volts.							
Total Plate Current	1075 amp.							

25 Cycle Total Watts	- 85							
Line Voltage - 115	Tran.	Osc.	I.F.	R.F.	Det.	2-247	280AC	280DC
Plate Voltage DC	220	40	230	230	160	225	325	340
Screen Voltage DC	70		70	70	25	230		
Heater Voltage AC	2.25	2.25	2.25	2.25	2.45	2.45	4.7	
Control Grid Voltage DC	10		2-38	2-38	20	15		
Speaker Field Voltage	- 100 Volts							
Total Plate Current	- .075 amp.							

Note: Control grid volts are measured from cathode to ground or cathode to heater. 247 grid voltage from grid to ground or filament.

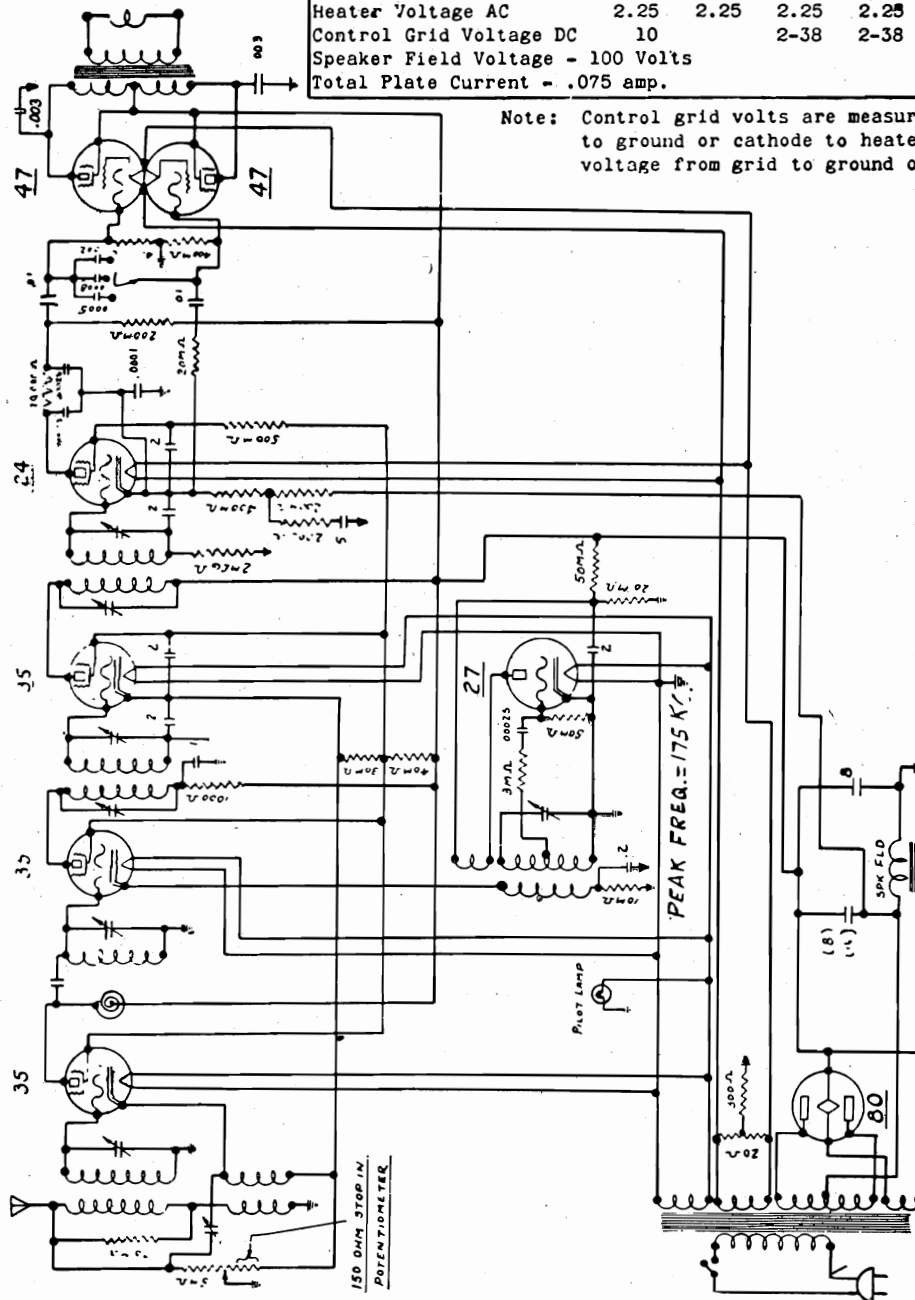

NOTE-In this set the hum across the field coil is used to buck out hum set up in the tube circuits. Causes of hum can be traced to defective detector or output tubes. (Interchange output tubes) Shorted condenser or open resistors in hum filter circuit. The hum filter circuit consists of a 2000 ohm resistor and a 0.5 condenser in the grid bias resistor circuit. This connects from the cathode of the detector to the negative side of the speaker field. Other causes of hum are Reversed speaker field, open or shorted condensers in detector circuit, open or grounded 20 ohm center tapped resistor, defective tone control, defective speaker or a defective electrolytic condenser.

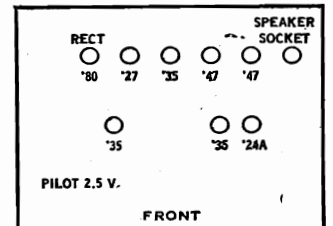

MODEL 1370

SEARS-ROEBUCK & CO.

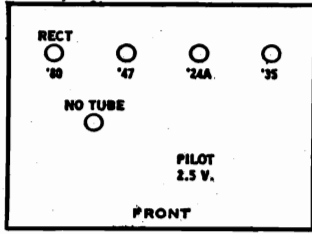
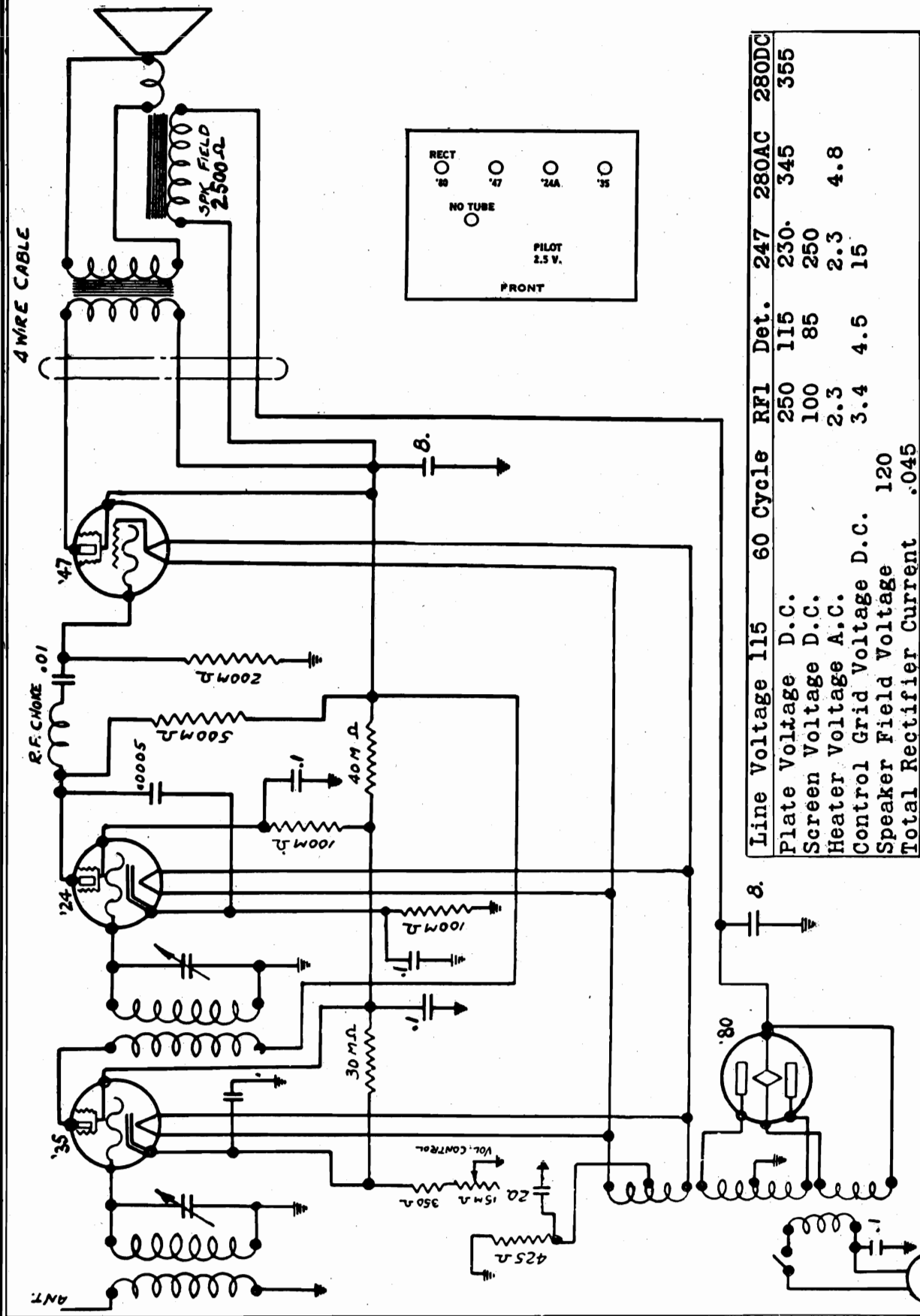

Line Voltage	115	60 Cycle	RFL	Det.	247	280AC	280DC
Plate Voltage D.C.	250	115	230	345	355		
Screen Voltage D.C.	100	85	250				
Heater Voltage A.C.	2.3	2.3	2.3	4.8			
Control Grid Voltage D.C.	3.4	4.5	15				
Speaker Field Voltage	120						
Total Rectifier Current	.045						

Note: Control grid volts are measured from Cathode to Ground or Cathode to Heater. 247 Grid voltage, from Filament to Ground. Volume control at minimum.

Power Consumption
60 cycle 56 Watt

SEARS-ROEBUCK & CO.

MODEL 1430
Parts-Voltage

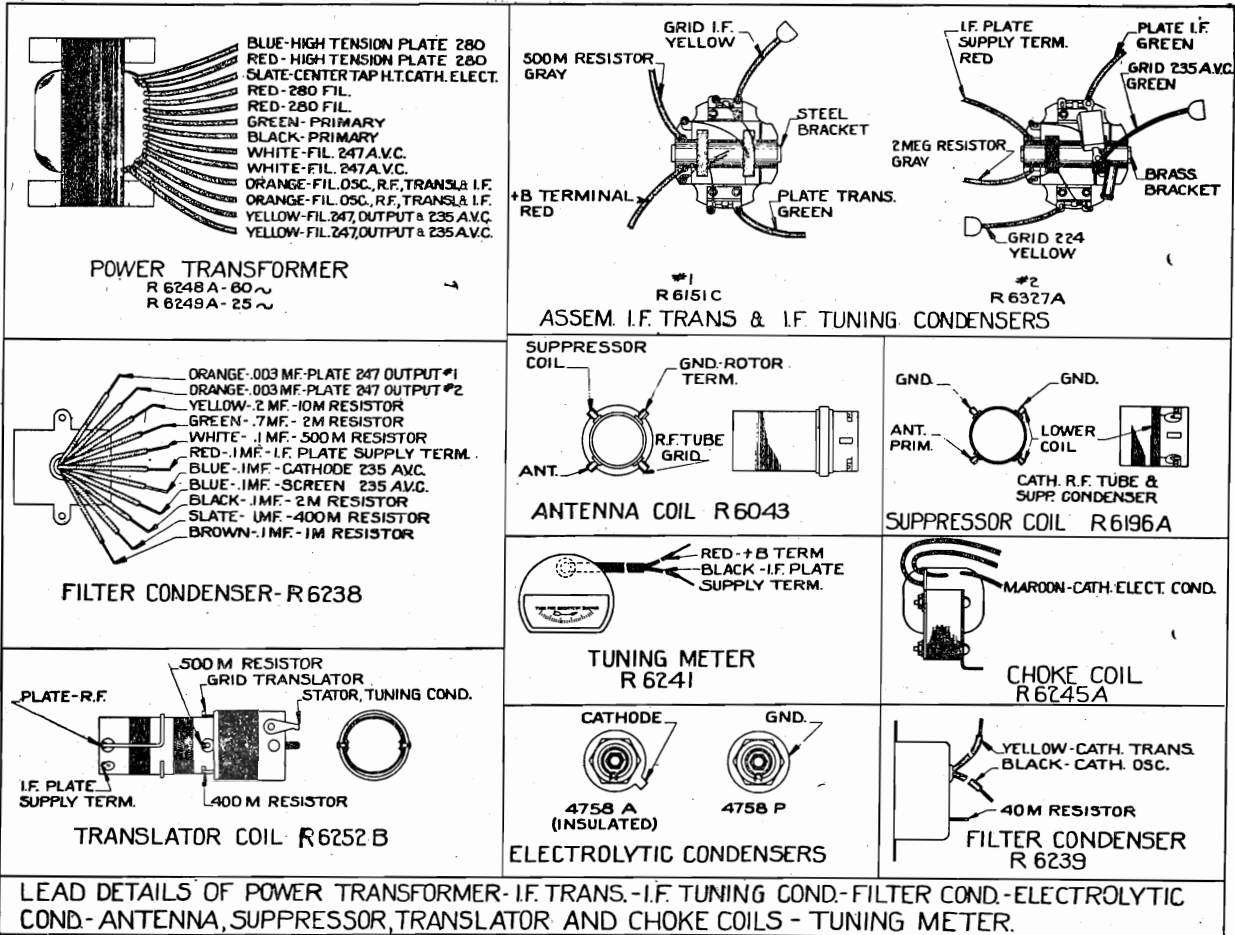

MODEL 1430 - 60 CYCLE

Line Voltage	115						#1	#2	AVC	AVC
Total Watts	100						247	247	Amp	280 280
		Trans	Osc.	IF	RF	Det	Output	Output	235 247	AC DC
Plate Voltage	230		20	230	230	160	230	230	230	340 340
Screen Voltage	70			70	70	25	230	230	70 100	
Grid Voltage	var			var.	var.	20	15	15	var. 18	
Filament Voltage	2.5	2.5	2.5	2.5	2.5	2.5	2.5	2.5	2.5 4.85	
Speaker Field Voltage	-		110							
Total Plate Current	-		80 ma.							

Note: All voltages measured with a 1000 ohm per volt meter, 250 volt scale, with volume level control at maximum. 247 output grid voltages were measured from filament to ground, and translator grid from cathode to ground. Grid voltages on the RF and IF will be variable when the set is operating. AVC plate voltages will be the grid voltages on RF IF and translator tubes.

Notes-Causes of no signals can be traced to some of the following reasons. Grid clips shorted to tops of tube shields. Open or shorted condensers. Unsoldered leads. Solder under tube socket terminals. Defective tubes. Oscillator not working. Open image suppressor coil. Defective speaker or shorted tone control connection. Poor quality can be traced to defective output or detector tubes. Set not tuned properly. A poor 235 in the IF, RF or translator sockets will give poor quality and unsatisfactory volume control. Shorted or open grid

coupling condenser in the audio circuit, or open resistors in the audio circuits will also contribute to poor quality. Oscillation can be traced to defective tubes, grid leads of detector and IF too close, or an open condenser in the plate circuit of the translator.

SEARS-ROEBUCK & CO.

MODEL Silvertone 218

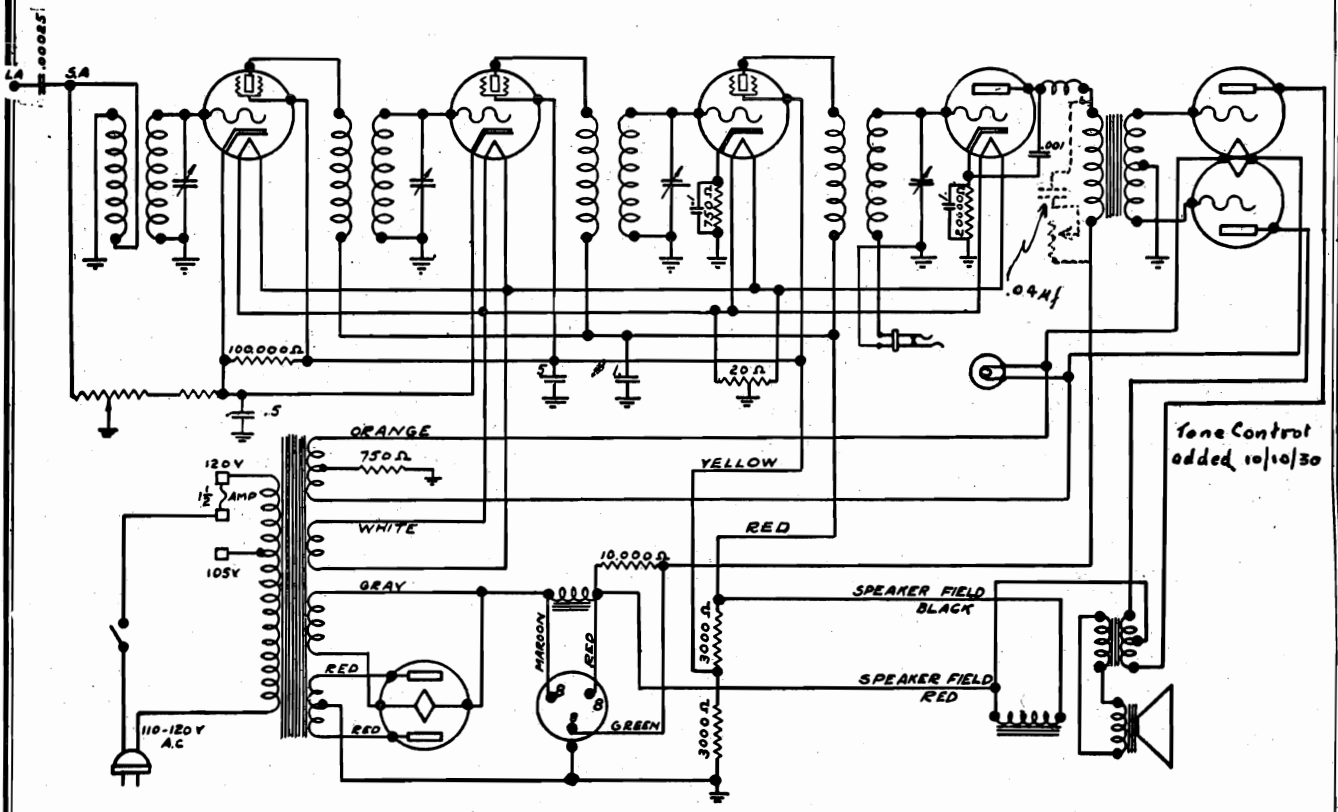

READINGS WITH PLUG IN SET SOCKET AND TUBE IN TESTER SOCKET

Tube No. in Order	Position of Tube	Type of Tube	A Volts	B Volts	C Volts	Cathode	Plate M.A.	Screen Grid Volts
1	1st R.F.	224	2.4	178	3.4	3.4	3.5	85
2	2nd R.F.	224	2.4	178	3.4	3.4	3.5	85
3	3rd R.F.	224	2.4	178	3.4	3.4	3.5	85
4	DET.	227	2.4	240	23.	2.5	1.1	
5	Push-Pull	245	2.4	235	45		27	
6	Push-Pull	245	2.4	235	45		27	
7	RECT.	280	5.	310				

Line Voltage 120

Set On 120 Volt Tap

Volume Control FULL ON

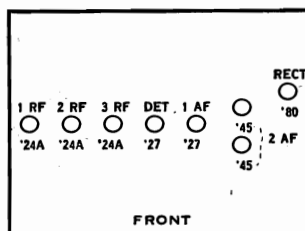

SEARS-ROEBUCK & CO.

MODEL 1462
 MODEL 1480,1482,
 1484

Model 1462

	Trans. 235	Osc. 227	IF 235	RF 235	247 Output	AVC 227	280 DC	Det 224
PLATE VOLTAGE	160	55	160	160	242	48	370	80
AVERAGE PLATE CURRENT MA	1.	-	5.	5.	26.	-	-	.2
SCREEN VOLTAGE	58	-	58	58	250	-	-	40
AVERAGE SCREEN CURRENT MA	.2	-	1.	1.	7.	-	-	.15
GRID VOLTAGE	10	-	1.5	1.5	18	-	-	6
FILAMENT VOLTAGE	2.4	2.4	2.4	2.4	2.6	2.5	5	2.5
SPEAKER FIELD VOLTAGE	83 volts		Line Voltage		115 volts			
TOTAL PLATE CURRENT	60 ma		Total Watts		85			

Model 1480,1482,1484

	Trans. 235	Osc. 227	IF 235	RF 235	Det 224	Pentode 247	280
PLATE VOLTAGE	230	55	230	230	75	220	360
AVERAGE PLATE CURRENT MA	1.	3.	5.	5.	.2	26.	
SCREEN VOLTAGE	55		55	55	38	230	
AVERAGE SCREEN CURRENT MA	.2		1.	1.	.15	7.	
GRID VOLTAGE	10		1.5	1.5	5	17	
FILAMENT VOLTAGE	2.47	2.52	2.54	2.56	2.5	2.49	5
SPEAKER FIELD	115 volts		LINE VOLTAGE		115		
TOTAL PLATE CURRENT	40 ma.		TOTAL WATTS		70		

MODEL 108-A,110

Voltage, Data

SENTINEL RADIO CORP.

VOLTAGE TABLE

Never check voltages until all tubes are fully warmed up to proper operating condition. The voltage table given below is taken at 115 volts line with a Model 547 Weston set checker. It must be remembered that the voltage readings taken vary directly as the line voltage and also with the accuracy of the meters used. A variation of 10% plus or minus is permissible.

TUBE VOLTAGES		115 V. Line Volume Control Full On				
Type of Tube	Position of Tube	Filament Volts	B Volts	C Volts	NORMAL PLATE M.A.	Screen Volts
227	Oscillator	2.4	62.5		4.75	
235	Radio Frequency	2.4	240	2.15	2.75	27
224	1st Detector	2.4	230	4.35	.5	65
235	Intermediate	2.4	237	2.15	2.75	72
224	2nd Detector	2.4	100*	2.1*	2.5	35*
247	Pentode	2.4	250	16.5**	32.5	250
280	Rectifier	4.95			27.ea.plate	

*These readings are only comparative and are not true voltages applied. The volt meter, when the readings are taken at these points, is in series with a very high resistance.

** To read the 247 bias, read between H.K. speaker socket and ground.

ALIGNMENT OF RECEIVER:

Because of the construction and thorough impregnation of the intermediate coils, the intermediate stages should rarely need re-tracking. Only when an intermediate coil has become defective due either to an open or burned out winding, should it be necessary to re-adjust the intermediate trimmers. Should this occur, it is necessary that an oscillator be used and the intermediate trimmers be adjusted at 175 kilocycles. To align the intermediate stages, connect the high side of the oscillator output to the grid circuit of the first detector, which is done by disconnecting the grid cap of the 224 first detector and connecting the high side of the test oscillator to the control grid of this tube. The ground side of the test oscillator should be connected to the ground post on the chassis. Set the oscillator at 175 kilocycles and adjust the output of the oscillator so that a convenient reading is obtained on the output meter. Be sure that the output from the oscillator is not so large that it will overload the second detector. If during the alignment the meter goes off scale, reduce the output of the test oscillator or adjust the receiver volume control.

The trimmers of the intermediate coils are accessible through the small holes in the top of the intermediate shield can. There are two trimmers to each intermediate coil. Align the grid trimmer of the first intermediate coil. After a maximum reading is obtained by adjusting the grid trimmer on the first intermediate, adjust the primary for maximum reading and then re-check the grid side to make certain the alignment of the secondary has not been changed by the adjustment of the primary. The same procedure is followed in aligning the second intermediate coils. After both intermediate coils are properly aligned the adjustment of the intermediate stage is complete and they should not be further disturbed.

Replace the grid cap on the first detector and connect the oscillator output leads to the antenna and ground posts of the receiver and set the oscillator at 1435 kilocycles. Then tune the receiver to 1435 kilocycles on the dial. It is important that the receiver be tuned to this point. If the receiver is out of the cabinet it will be necessary to use some temporary indicator so that the position 1435 kilocycles on the dial may be accurately located. (This indicator should be set so that when the variable condensers are at the maximum capacity stop the indicator points to the last line on the dial at the low frequency end.) Then track the variable condensers by adjusting the trimmer condensers in the following order: Oscillator, antenna and radio frequency - (reading from the front of the receiver toward the back, the variable condenser sections are: Oscillator, antenna and radio frequency). After the variable condensers have been properly tracked at 1435 kilocycles, adjust the oscillator to 1295 kilocycles. Tune the receiver to this frequency. Check alignment of the condensers at this point by bending the end plate of the rotors in and out, noting the change in reading on the output meter. If when the plates are bent in the reading is increased, it is an indication that that particular section requires more capacity and the end plate should be permanently bent in at this point; or, if when the end plate is bent away, the reading is increased, the end plate should be bent away permanently, as it is an indication that that particular section requires less capacity at that particular point. The variable condensers should be checked in this manner at 1295, 880, 650 and 550 kilocycles. These points have been chosen so as to take advantage of the slots in the end plates of the variable condensers. This procedure of bending plates should rarely be necessary on the oscillator section, as the plates of the oscillator section are especially designed to properly track over the broadcast spectrum, providing the antenna and radio frequency stages are correctly aligned.

ANTENNA:

Satisfactory radio reception is largely dependent upon a proper antenna and ground installation. It is not possible to prescribe any definite form of antenna construction, as the most satisfactory aerial for any particular installation will vary in different locations, depending largely upon local structural details and sources of interference. Because of the enormous amplification obtained from the superheterodyne receiver, a large antenna is not desirable nor necessary. An antenna of from 15 to 35 feet, including lead-in and ground, will in most installations be ample. In congested districts an excessively long antenna will result in apparent loss of tone quality and increased hum. In isolated communities where distant daylight reception is desired, the length of the antenna may be increased so as to obtain satisfactory reception.

While in most installations A.C. receivers apparently work almost as well without a ground as they do with one, in no case should an installation be made where the receiver is not connected to a good ground. Water pipes and steam radiators generally make satisfactory grounds. The ground lead should be connected by means of an approved ground clamp or soldered to a section of the pipe that has been thoroughly cleaned. If neither are available a 6 ft. iron pipe driven in the ground, preferably in a position where the soil is moist, will be satisfactory.

SENTINEL RADIO CORP.

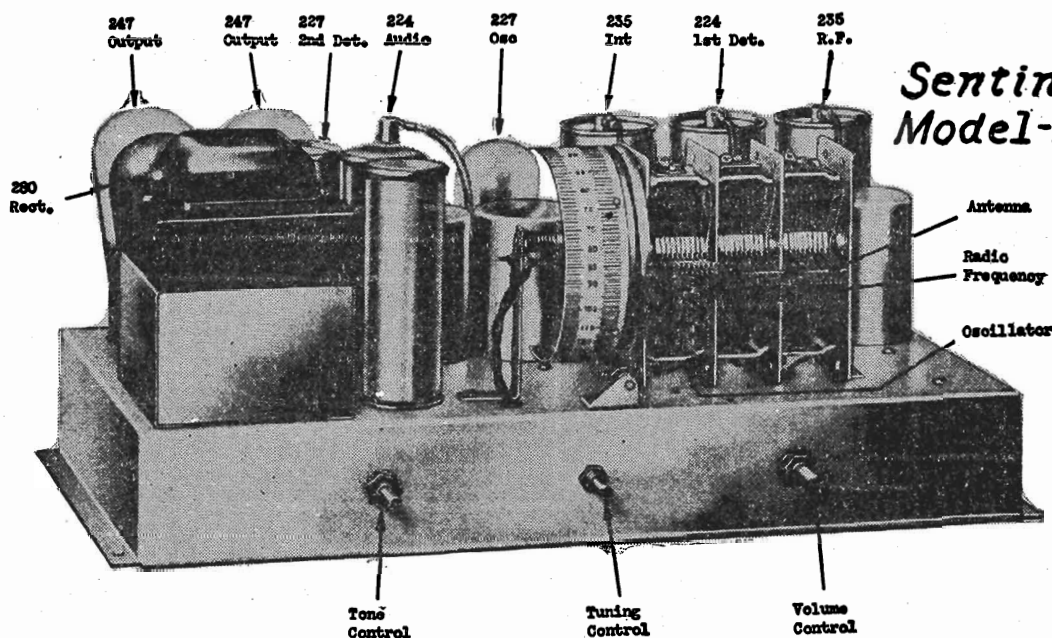
MODEL 114
Voltage- Data**ALIGNMENT OF RECEIVER:**

Because of the construction and thorough impregnation of the intermediate coils, the intermediate stages should rarely need retracking. Only when an intermediate coil has become defective due to an open or burned out winding, should it be necessary to readjust the intermediate trimmers. Should this occur, it is necessary that an oscillator be used and the intermediate trimmers be adjusted at 175 kilocycles. To align the intermediate stages, connect the high side of the oscillator output to the grid circuit of the first detector, which is done by disconnecting the grid cap of the 224 first detector and connecting the high side of the test oscillator to the control grid of this tube. The ground side of the test oscillator should be connected to the ground post on the chassis. Set the oscillator at 175 kilocycles and adjust the output of the oscillator so that a convenient reading is obtained on the output meter. Be sure that the output from the oscillator is not so large that it will overload the second detector. If during the alignment the meter goes off scale, reduce the output of the test oscillator or adjust the receiver volume control.

The trimmers of the intermediate coils are accessible through the small holes in the bottom of the chassis. There are two trimmers to each intermediate coil. Align the grid trimmer of the first intermediate coil. After a maximum reading is obtained by adjusting the grid trimmer on the first intermediate, adjust the primary for maximum reading and then recheck the grid side to make certain the alignment of the secondary has not been changed by the adjustment of the primary. The same procedure is followed in aligning the second intermediate coils. After both intermediate coils are properly aligned the adjustment of the intermediate stage is complete and they should not be further disturbed.

Replace the grid cap on the first detector and connect the oscillator output leads to the antenna and ground posts of the receiver and set the oscillator at 1435 kilocycles. Then tune the receiver to 1435 kilocycles on the dial. It is important that the receiver be tuned to this point. If the receiver is out of the cabinet it will be necessary to use some temporary indicator so that the position 1435 kilocycles on the dial may be accurately located. (This indicator should be set so that when the variable condensers are at the maximum capacity stop the indicator points to the last line on the dial at the low frequency end.) Then track the variable condensers by adjusting the trimmer condensers in the following order: Oscillator, antenna and radio frequency - (reading from the front of the receiver toward the back, the variable condenser sections are: Oscillator, antenna and radio frequency). After the variable condensers have been properly tracked at 1435 kilocycles, adjust the oscillator to 1295 kilocycles. Tune the receiver to this frequency. Check alignment of the condensers at this point by bending the end plate of the rotors in and out, noting the change in reading on the output meter. If when the plates are bent in the reading is increased, it is an indication that that particular section requires more capacity and the end plate should be permanently bent in at this point; or, if when the end plate is bent away the reading is increased, the end plate should be bent away permanently, as it is an indication that that particular section requires less capacity at that particular point. The variable condensers should be checked in this manner at 1295, 895, 650 and 550 kilocycles. These points have been chosen so as to take advantage of the slots in the end plates of the variable condensers. This procedure of bending plates should rarely be necessary on the oscillator section, as the plates of the oscillator section are especially designed to properly track over the broadcast spectrum, providing the antenna and radio frequency stages are correctly aligned.

Tube Voltages

Type of tube	Position of Tube	Filament Volts	B Volts	C Volts	Normal Plate M.A.	Screen Volts
227	Oscillator	2.4	62.5		4.75	
235	Radio Frequency	2.4	240	2.15	2.75	27
224	1st Detector	2.4	230	4.35	.5	65
235	Intermediate	2.4	237	2.15	2.75	72
227	2nd Detector	2.4				
247	Pentode	2.4	220	8.**	32.5	250
247	Pentode	2.4	220	8.**	32.5	250
280	Rectifier	4.9			47.5 ea. plate	
224	1st Audio	2.4	100	2.1*	.5	35*

115 V. line Volume Control Full On

**To read the 247 bias, read between 247 grid and ground.

*These readings are only comparative and are not true voltages applied. The volt meter, when the readings are taken at these points, is in series with a very high resistance.

SENTINEL RADIO CORP.

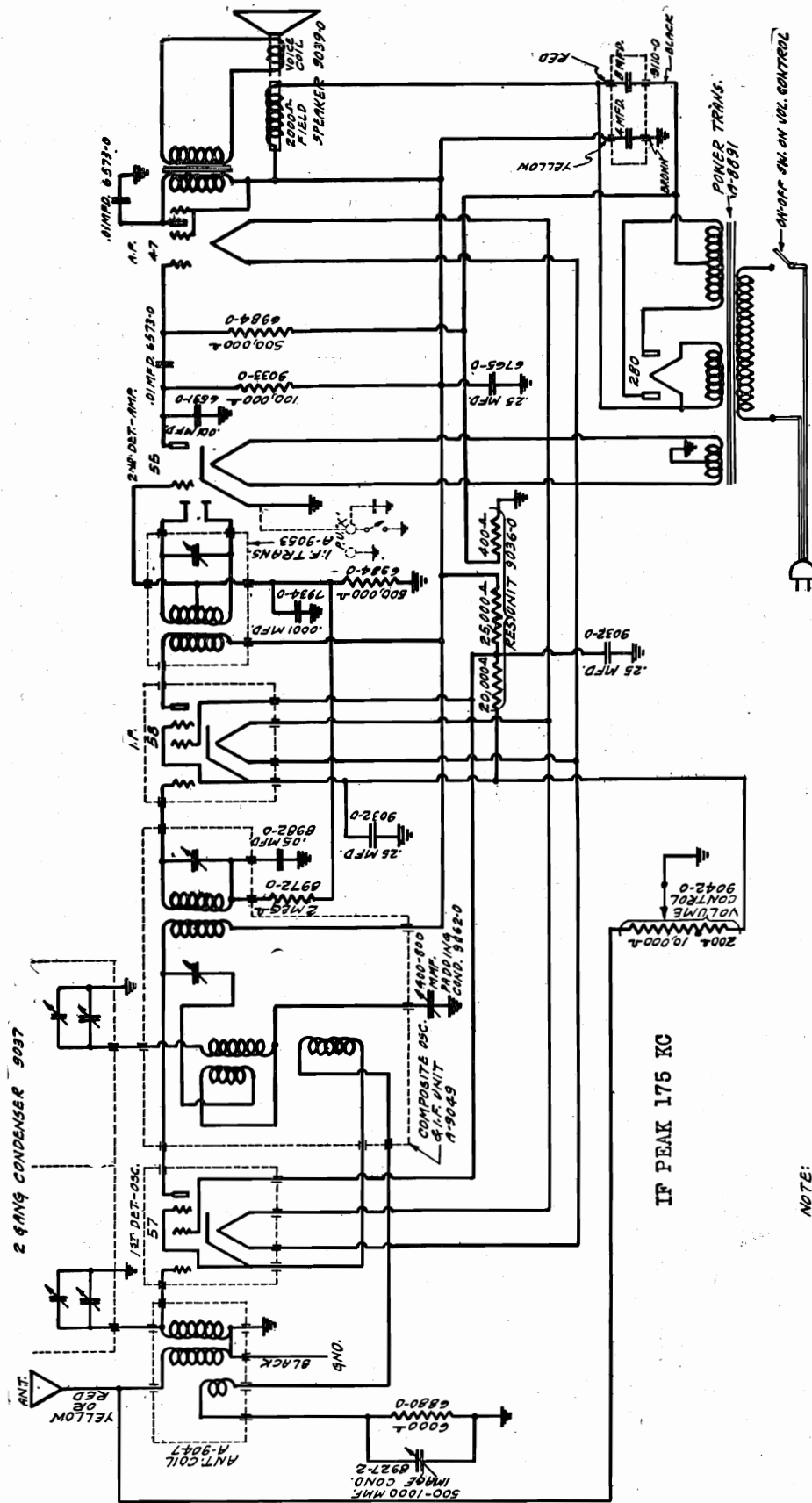

NOTE:

1. DOTTED LINES DENOTE SHIELDING
2. ALL NUMBERS SHOWN RELATIVE TO PARTS ARE OUR PART NOS
3. NUMBERS SHOWN WITH PREFIX "A" ARE COMPLETE ASSEMBLIES.
4. WHEN PHONO JKS. ARE USED, CATHODE OF 55 TUBE IS CONNECTED TO POINT MARKED "X"

MODEL 31,33
MODEL 550

SENTINEL RADIO CORP.

PART NO. 20049
DATE 3-14-33
DRAWING DATE 1-20-33

NOTE:
DOTTED LINES DENOTE SHIELDING.
CAPACITORS ARE TO BE WAXED TO
SLOTS IN THE CHASSIS.
RESISTORS SHOWN WITH PREFIX "R" ARE
COMPLETE ASSEMBLIES

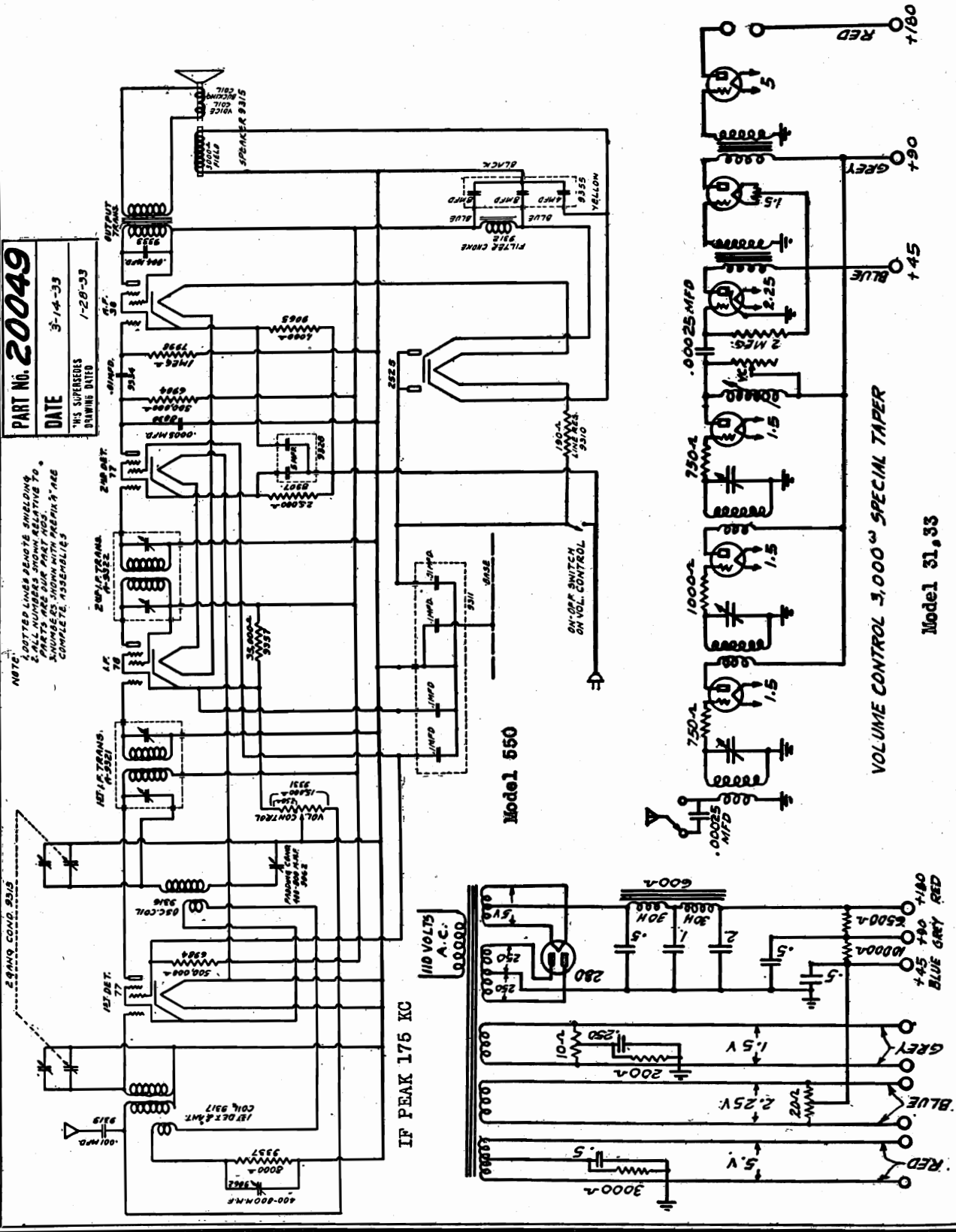

Model 550

IF PEAK 175 KC

VOLUME CONTROL 3,000Ω SPECIAL TAPER

Model 31,33

SILVER - MARSHALL, INC.

MODEL 716
MODEL 683
Schematic Data

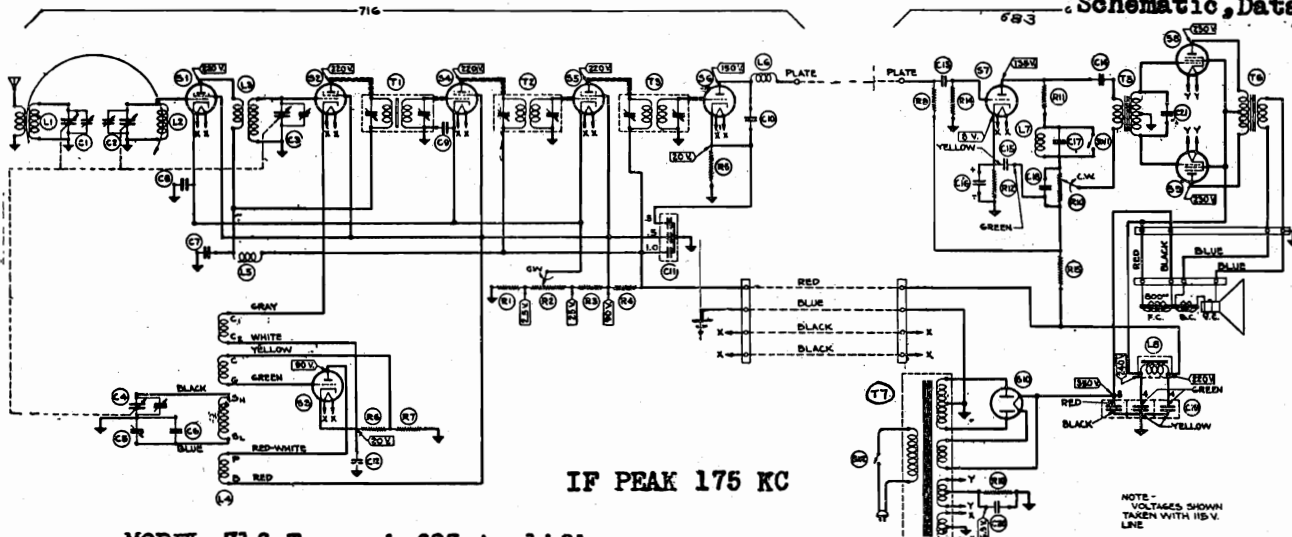

IF PEAK 175 KC

MODEL 716 Tuner & 683 Amplifier and Power Supply

There are two mounting holes left open on the tuner chassis for mounting the variable bass, and the high tone controls that are connected to flexible leads on the 683 amplifier.

Looking at the rear of the tuner, the antenna and ground posts are mounted on the top left of the chassis. On the right rear of the chassis is the output post marked "plate" This is connected to the input post on the 683 amplifier.

In the rear center of the chassis is a four terminal strip, color coded as follows: Red, Blue, Black, Black. A coded cable is furnished with the tuner for connecting this terminal strip to the 683 or similar amplifier.

The color code reads as follows: Red-B positive 240 volts, Blue-B negative or ground, Black, Black - 2 1/2 volt heater or filament supply. The cable supplied with the tuner contains two heavy duty filament lead wires colored Green-Black and connect to the two Black terminals on this strip.

There are two sets of four terminal lugs on the back of the amplifier. Looking at the rear of the amplifier the set on the right are connections for the SM 855B speaker or similar type of speaker, Cable is furnished with the amplifier. This terminal strip is color coded as follows: red, black, blue, blue. The two blue leads connect to the speaker voice coil, the red and The SM 855B

- C1 -
- C2 -
- C3 -
- C4 - Variable Condenser 365 Mmfd. Max - 5 Mmfd. 13217
- C5 - Osc. Trimmer Cond. - 120 to 325 Mmf. 16035
- C6 - 500 Mmfd. Cond. Mica - 10% 450-500 (Blue) 500-550 (Red) "
- C7 - .1 Mfd. Cond. 200 V. Sprague 3220
- C8 - .1 Mfd. Cond. 200 V. " 3220
- C9 - .1 Mfd. Cond. 200 V. " 3220
- C10 - .001 Mfd. Cond. Mica 7039
- C11 - .5, .5, 1.0 Mfd. Cond. (.5-200V.) (1.0-300V.) 13140
- C12 - .1 Mfd. Cond. 200V. 3220
- C13 - .02 Mfd. Cond. 500V. 13195
- C14 - .04 Mfd. Cond. 7046
- C15 - 4 Mfd. Cond. Dry Electro 450V. 13177
- C16 - 10 Mfd. Cond. Dry Electrolytic (25V.) 13023
- C17 - .01 Mfd. Cond. Mica 7047
- C18 - 0.25 Mfd. Cond. 500V. Sprague 3322
- C19 - 2 Mfd. Cond. Dry Electrolytic (450V.) 13177
- 1 8Mfd. Cond. " " 13181
- 1 450V. " " 3220
- C20 - .1 Mfd. Cond. 200V. 3220
- C21 - .00025 Mfd. Cond. Mica 3330
- L1 -
- L2 - 170 A Coil 4743
- L3 - 176 Coil 14342
- L4 - 179 Coil 14694
- L5 - 281 R.F. Choke 4726
- L6 - 281 R.F. Choke 4692
- L7 - 10164 Air Cone Choke 14723
- L8 - 10145 Choke 14693
- R1 - 100 Ohm Resistor - wire wound 4743
- R2 - 4500 Ohm Volume Control 14342
- R3 - 13,000 Ohm Resistor - 1 Watt. Carbon, Brown, Orange, Or. 14694
- R4 - 10,000 Ohm Resistor - 2 Watt. Carbon, Brown, Black, Or. 4726
- R5 - 60,000 Ohm Resistor - 1 Watt. Carbon, Blue, Black, Or. 4692
- R6 - 100 Ohms } Wire wound tapped resistor No color 14723
- R7 - 1700 Ohms }
- R9 - 30,000 Ohm Resistor - 1 Watt. Carbon, Orange, Black, Or. 14693
- R10 - 10,000 Potentiometer 4492
- R11 - 720 Ohm Resistor - wire wound No color 4786
- R12 - 2,600 Ohm Resistor - 1 watt Carbon Red, Blue, Red. 4770
- R13 - 220 Ohm Resistor - 2 Watt. Ohmite (Red Devil) 14692
- R14 - 300,000 Ohm Resistor 1 Watt. Carbon, Orange, Black, Vel. 4685
- R15 - 10,000 Ohm Resistor 1 Watt. Carbon, Brown, Black, Orange 14696
- S1-S4-S5 - '51 Tubes
- S2 - '24 "
- S3-S6-S7 - '27 "
- S8-S9 - '47 "
- S10 - '80 "
- SW1 - Tone Control Switch
- SW2 - On-Off Switch (Combines with R2)
- T1 - 1st I.F. Transformer (G-1)
- T2 - 2nd I.F. Transformer (G-4) Same spacing as G-3
- T3 - 3rd I.F. Transformer (G-3)
- T5 - 10159 Input Transformer
- T6 - 10143 Output Transformer
- T7 - 3470 Power Transformer.

List of Parts Used in 716 and 683.

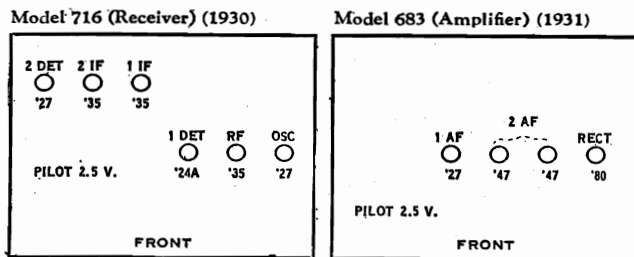

SILVER MARSHALL, INC.

MODEL 727 SW - All Wave
Parts List

L1 - 197 Broadcast Antenna Coil (550-1500 K.C.)	T1 - Q-1 I. F. Transformer	C1-C2 - 2 Gang Variable Condenser-365 mmfd. Max. ± 5 mmfd.	13372
L2 - 202 Short Wave Antenna Coil (1.56-3.46 megacycles)	T2 - Q-2 I. F. Transformer	0°-90° ± 1 mmfd. 90°-180° $\pm \frac{1}{2}$ of 1%	
L3 - 201 Short Wave Antenna Coil (3.51-5.36 megacycles)	T3 - Q-4 I. F. Transformer	C3 - 25 Mmfd. Trimmer Cond.	16249
L4 - 200 Short Wave Antenna Coil (5.54-10.29 megacycles)	T4 - 10208 Output Transformer	C4 - 200 Mmfd. Variable trimmer condenser	13302
L5 - 199 Short Wave Antenna Coil (9.6-18.15 megacycles)	T5 - 10202 Power Transformer	C5 - 0.1 Mfd. Condenser - Sprague 200 V.	3220
L6 - 198 Oscillator Coil	S1 - '24 Tube	C6 - 0.1 Mfd. Condenser - Sprague 200 V.	3220
L7 - 281 R.F. Choke	S2-S3 - '51 Tubes	C7 - 0.1 Mfd. Condenser - Sprague 200 V.	3220
L8 - 283 R.F. Choke	S4-S7-S8-S9 - '27 Tubes	C8 - 0.1 Mfd. Condenser - Sprague 200V.	3220
	S5-S6 - '47 Tubes	C9 - 0.1 Mfd. Condenser - Sprague 200 V.	3220
		C10 - $\frac{1}{2}$ Mfd. Condenser - Polymet Waxtite 200 V.	13329
		C11 - .001 Mfd. Condenser - Mica	7039
		C12 - .001 Mfd. Condenser - Mica	7039
		C13 - .025 Mfd. Condenser - Sprague 200 V.	3333
		C14 - .025 Mfd. Condenser - Sprague 200 V.	3333
		C15 - .03 Mfd. Condenser - Sprague 700 V.	13331
		C16 - .00015 Mfd. Condenser - Mica	3313
		C17 - Oscillator Trimmer Condenser	16179
		C18 - 0.1 Mfd. Condenser - Sprague 200 V.	3220
		C19 - 0.1 Mfd. Condenser - Sprague 200 V.	3220
		C20 - 0.15 Mfd. Condenser - Sprague	13145
		C21 - .0005 Mfd. Condenser - Mica	7052
		C22 - 0.1 Mfd. Condenser - Sprague 200 V.	3220
		C23 - 1.0, .5, .5 Mfd. Condenser	13140
		C24 - 8 Mfd. Dry Electrolytic Cond. 450 V.	13181
		C25 - 12 Mfd. Dry Electrolytic Cond. 450 V.	3162
		M - Tuning Meter - 15 M.A.	13923
		P1 - 100,000 Ohm Pot. (Tone control)	14438
		P2 - 250,000 Ohm Pot.	
		(Volume control-Comb. with A.C. Switch)	4360
		R1 - 100,000 Ohm Resistor - 1 watt carbon	14691
		R2 - 250 Ohm Resistor - wire wound	4725
		R3 - 60,000 Ohm Resistor - 1 watt carbon	4695
		R4 - 25,000 ohm Resistor - 1 watt carbon	4697
		R5 - 500,000 Ohm Resistor - 1 watt carbon	4772
		R6 - 100,000 Ohm Resistor - 1 watt carbon	14691
		R7 - 5,000 Ohm Resistor - 1 watt carbon	14765
		R8 - 1 Megohm Resistor - 1 watt carbon	4759
		R9 - 1 Megohm Resistor - 1 watt carbon	4759
		R10 - 1 Megohm Resistor - 1 watt carbon	4759
		R11 - 12,000 Ohm Resistor - 1 watt carbon	4746
		R12 - 9,000 Ohm Resistor - 1 watt carbon	14746
		R13 - 8,250 Ohm)	
		R14 - 6,500 Ohm) 14,750 Ohm R.D. Ohmite - 3 watt	14781
		R15 - 300,000 Ohm Resistor - 1 watt carbon	4685
		R16 - 400 Ohm Resistor - wire wound	4701
		R17 - 400 Ohm Resistor - wire wound	4701
		R18 - 300,000 Ohm Resistor - 1 watt carbon	4685
		R19 - 3,500 Ohm Resistor - 1 watt carbon	4804
		R20 - 60,000 Ohm Resistor - 1 watt carbon	4695
		SW1-SW2 - Tandem change-over switch	15298
		SW3 - A.C. switch (Combination with volume control)	

MODEL 727 SW-All Wave
Schematic, Data

SILVER - MARSHALL, INC.

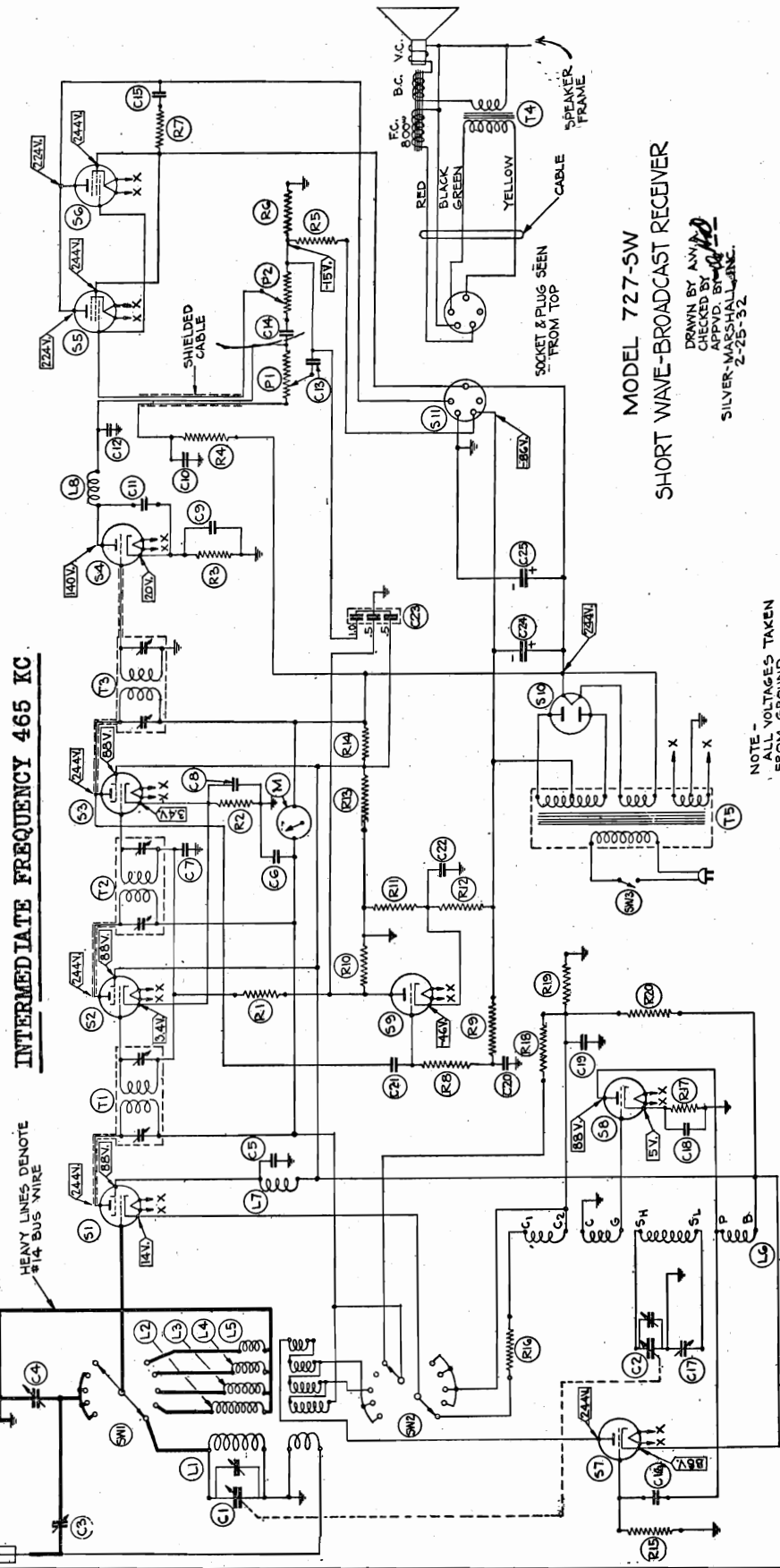

MODEL 727-SW
SHORT WAVE-BROADCAST RECEIVER

DRAWN BY ANV
CHECKED BY [Signature]
APPROVED BY [Signature]
SILVER-MARSHALL, INC.
2-25-32

DWG. No. 155-4

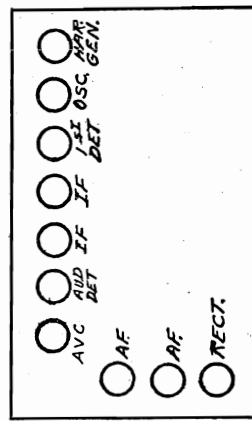

The Clough scheme is to use only one oscillator in the set, which must tune from 16.5 to 550 meters, or 18,000 to 550 kc. This is impossible, for even the harmonics of the oscillator are too weak to be of direct use. The crux of the idea lies in the use of a tube directly coupled to the oscillator, which is so set as to tune over the broadcast band of 550 to 1500 kc., this tube acting as a harmonic generator and providing the necessary local frequencies to heterodyne signals in the 16 to 35, 35 to 65, 65 to 100 and 100 to 200 meter short wave bands. This system results in only one permanently connected and aligned oscillator circuit, the harmonic generator tube providing the required heterodyne voltages for the short wave bands. A single selector switch knob gives a choice of five separate coils to enable the first detector to cover the short wave and broadcast bands. In the final embodiment, one dial tunes the broadcast band, this same dial plus an auxiliary trimmer tunes the short wave bands, and one five position switch selects the five bands at will!

NOTE - ALL VOLTAGES TAKEN FROM GROUND.

SILVER - MARSHALL, INC.

MODEL C

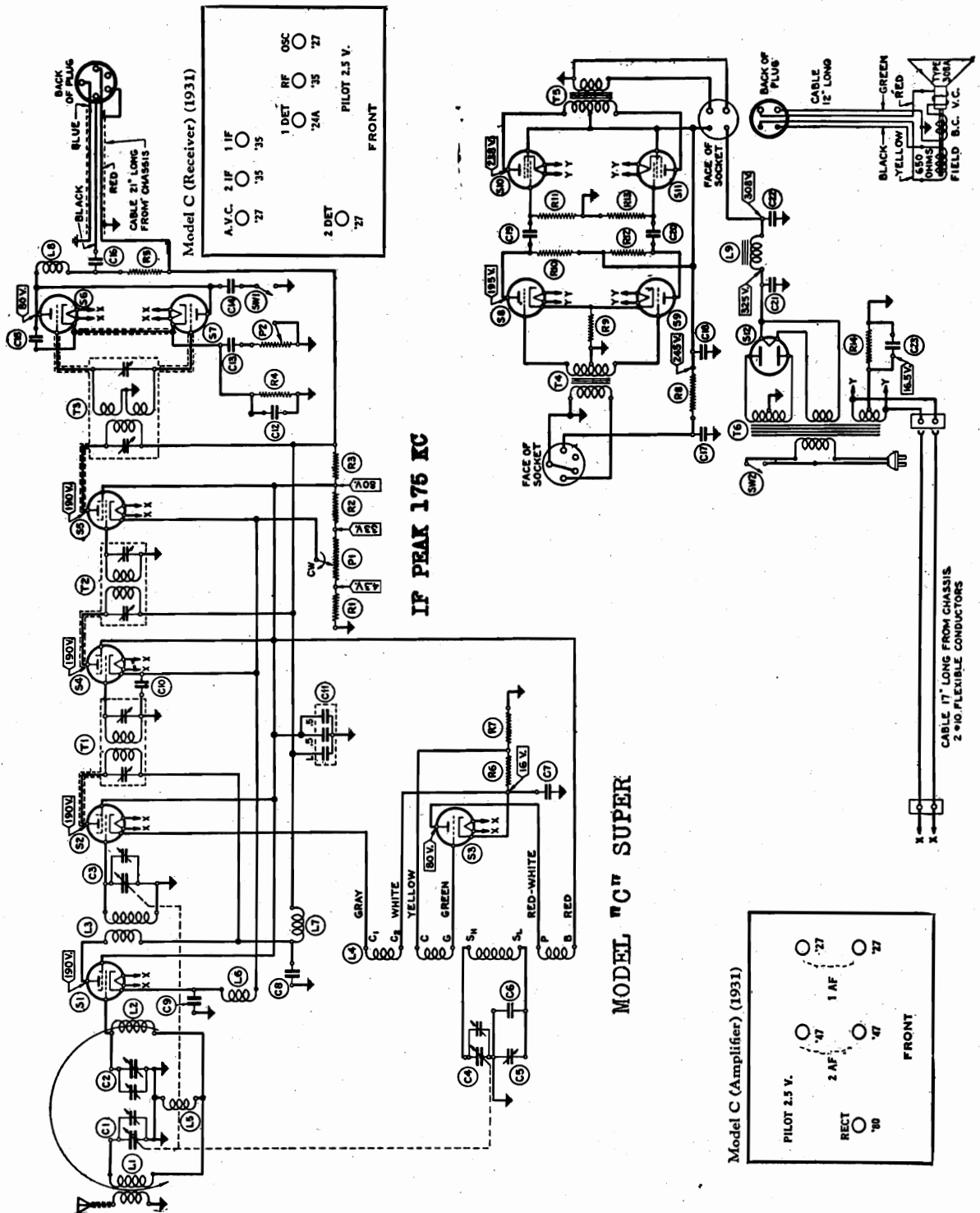

MODEL C
Parts List
SILVER - MARSHALL, INC.
MODEL "C" SUPERHETERODYNE (60 ~)

C1-C2-C3-C4 - 365 Mmfd. Condenser \pm 5 Mmfd. Max.	13217
C5 - Trimmer Cond. 120-325 Mmfd.)16035
C6 - 750 Mmfd. Cond.(mica) \pm 10%(675-750Blue)(750-825Red)	
C7-C8-C9 - .1 Mfd. Cond.	3220
C10 - .25 Mfd. Cond. (1.Mfd. Cond.-300 V.)	7114
C11 - (.5 Mfd. Cond-200V.) (.5 Mfd. Cond - 200 V)	13140
C12 - .04 Mfd. Cond.	7046
C13 - 1.Mfd. Cond. 150 V.Rating	3254
C14 - .025 Mfd. Cond.	3333
C15 - .001 Mfd. Cond.	7039
C16 - .08 Mfd. Cond.	13288
C17 - 8 Mfd. Cond.-450 V.Rating (Dry Electrolytic)	13181
C18 - 4 Mfd. Cond.-450 V.Rating (Dry Electrolytic)	13177
C19-C20 - .15 Mfd. Cond.	13145
C21 - 2 Mfd. Cond. - 600 V.Rating (Paper)	3328
C22 - 8 Mfd. Cond. - 450 V.Rating (Dry Electrolytic)	13181
C23 - .1 Mfd. Cond.	3220
L1 - 194s ANTENNA Coil	
L2 - 193s R.F.Coil	
L3 - 195s R.F.Coil	
L4 - 196s OSC.Coil	
L5 - 30 C Coupling Coil	
L6-L7-L8 - 281 Choke Coil	
L9 - 339U Filter Choke	
P1 - 4500 Ohm Potentiometer	14419
P2 - 20,000 Ohm Potentiometer	14427
R1 - 400 Ohm Resistor, Wire wound Blue	4701
R2 - 10,000 Ohm Resistor, 1 watt, Brown,Black,Orange	14696
R3 - 10,000 Ohm Resistor, 2 watt, Brown,Black,Orange	4726
R4-R5 - 25,000 Ohm Resistor, 1 watt, Brown,Black,Orange	4697
R6 - 100 Ohm Resistor)	14723
R7 - 1700 Ohm Resistor) wire wound	
R8 - 2600 Ohm Resistor 1 watt, Red,Blue,Red	4770
R9 - 1350 Ohm Resistor 1 watt,	14767
R10-R12 - 10,000 Ohm Resistor 1 watt, Brown,Black,Orange	14696
R11-R13 - 300,000 Ohm Resistor 1 watt, Orange,Black,Yellow	4685
R14 - 220 Ohm Resistor, 2 watt, Ohmite Red Devil	14766
SW1 - Tone Control Switch	5485
SW2 - On-Off Switch	5199

MODEL G

SILVER - MARSHALL, INC.

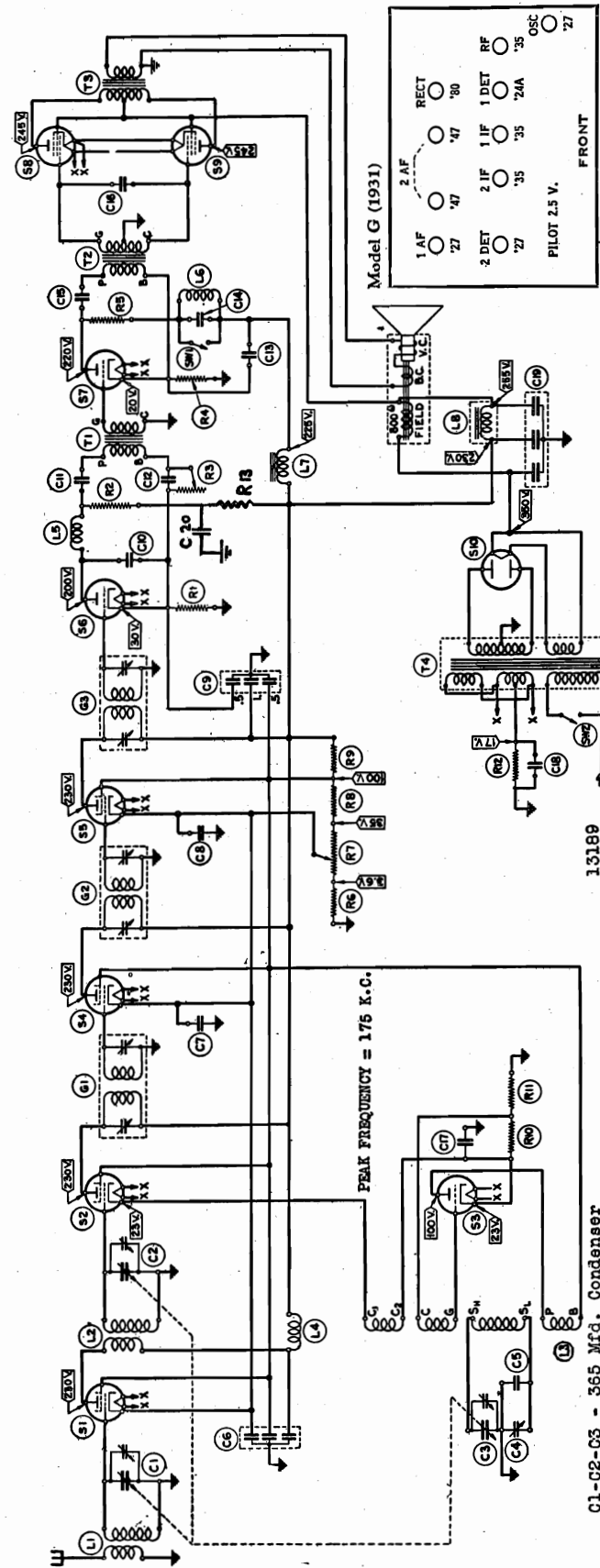

- 13189
16097
3316
3220
13140
7039
13195
7039
13177
7047
7050
7144
3220
13120
13177
- C1-C2-C3 - 365 Mfd. Condenser
C4 - Variable 250-600 Mmfd. }
C5 - 500 Mmfd. Cond. (Mica) }
C6 - Triple .1 Mfd. Cond.
C7-C8 - .1 Mfd. Cond. 200 V Rating
C9 - .5 - .5 - 1. Mfd. Cond.
C10 - .001 Mfd. Cond. Mica
C11 - .02 Mfd. Cond.
C12 - .001 Mfd. Cond. Mica
C13 - 4 Mfd. Cond. - 450V Rating
C14 - .01 Mfd. Cond.
C15 - .06 Mfd. Cond.
C16 - .00075 Mfd. Cond. Mica
C17-C18 - .1 Mfd. Cond. - 200V Rating
C19 - Three 4 Mfd. Units 450V Rating
C20 - 4 Mfd. Cond.
G1 - 1st I.F. Transformer
G2 - 2nd I.F. Transformer
G3 - 3rd I.F. Transformer
G20 -
L1 - 182 Ant. Coil
L2 - 178 R.F. Coil
L3 - 179 Osc. Coil
L4 - 281 Choke Coil
L5 - 281 Choke Coil
L6 - 10164 Choke Coil
L7 - 10145 Choke
L8 - 10145 Choke
- (.5 - 200V rating
(1.0- 500V rating
- 13189
16097
3316
3220
13140
7039
13195
7039
13177
7047
7050
7144
3220
13120
13177
- R1 - 60,000 ohm resistor
R2 - 30,000 ohm
R3 - 1 Megohm variable resistor
R4 - 2600 ohm resistor
R5 - 1000 ohm resistor
R6 - 300 ohm resistor
R7 - 4500 ohm potentiometer with on-off switch
R8 - 13,500 ohm resistor
R9 - 10,000 ohm resistor
R10 - 100 ohm resistor (wire wound)
R11 - 1700 ohm resistor
R12 - 210 ohm resistor
R13 - 10,000 Ohm
S1 - '51 Tube
S2 - '24 "
S3 - '27 "
S4-S5 - '51 "
S6-S7 - '27 "
S8-S9 - '47 "
S10 - '80 "
- T1 - 10149 Transformer (Specification 8-7-31)
T2 - 10159 Transformer (Specification 8-7-31)
T3 - 10143 Transformer
T4 - 10177 Transformer 60 Cycle
- SW1 - Tone Control Switch
SW2 - On-Off Switch (Combined with volume control)
- 1 watt
1 watt
1 watt
1 watt
wire wound
1 watt
2 watt
2 watt - carbon
4698
14693
14371
4770
14722
14692
14323
14694
4726
14723
4774
14696

5485

SILVER - MARSHALL, INC.

MODEL J

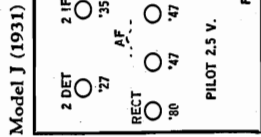
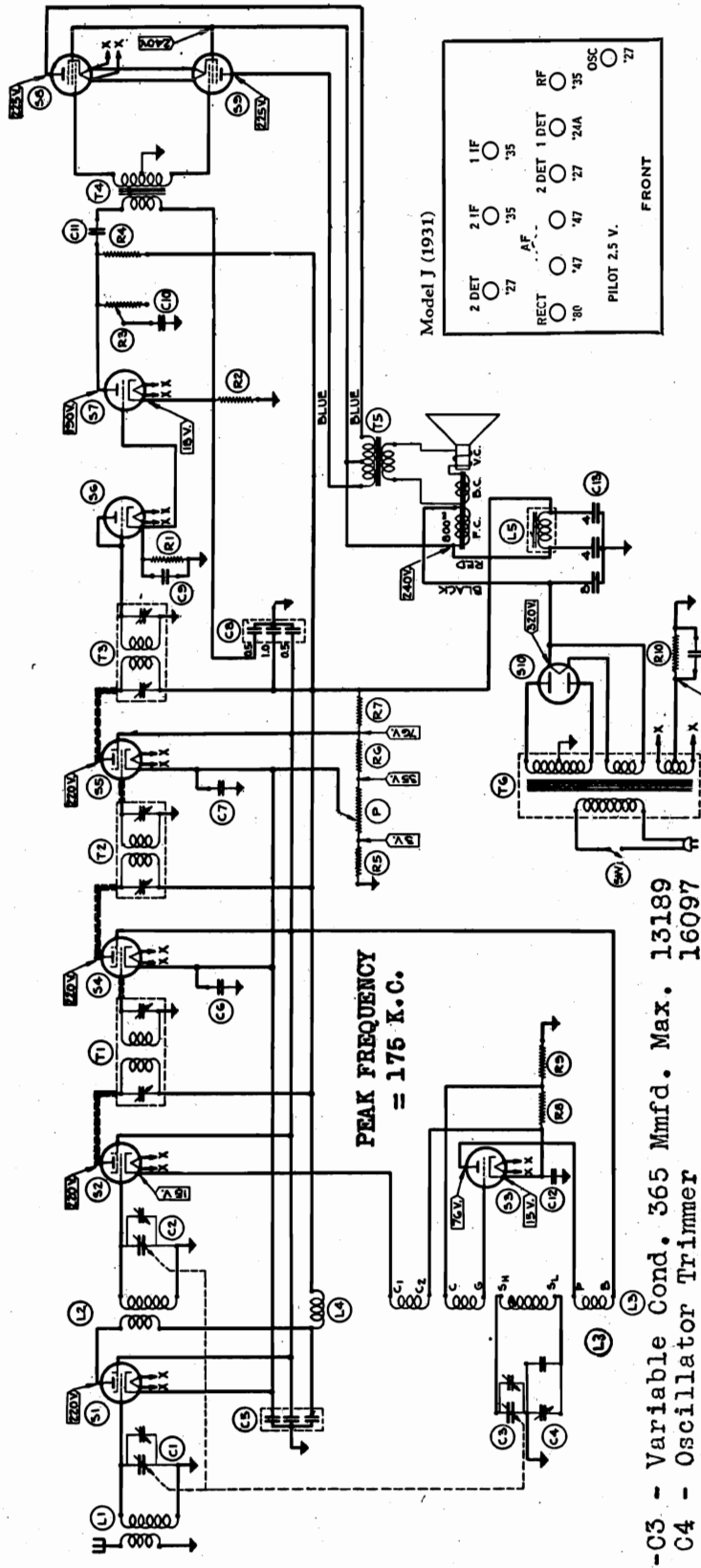

P-4500 Ohm Potentiometer (Combination)
 SW-On-Off A.C.Switch (Combined with Pot)

- C1-C2-C3 - Variable Cond. 365 Mmfd. Max. 13189
- C4 - Oscillator Trimmer 16097
- C5 - Triple 0.1 Mfd. Cond. 3316
- C6 - 0.1 Mfd. Cond. 200 V. Rating 3220
- C7 - 0.1 Mfd. Cond. 200 V. Rating 3220
- C8 - .5, .5, 1.0 Mfd. Cond.
- C9 - (10, 300 V. 0.5, 0.5-200 V.) 13140
- C9 - .00015 Mfd. Cond. Mica
- C10 - .06 Mfd. Cond.
- C11 - 0.15 Mfd. Cond.
- C12 - 0.1 Mfd. Cond. 200 V. Rating
- C13 - Two 4 Mfd. (Dry Electro.) 450 V. Rating
- C13 - One 8 Mfd. (" " " " " "
- C14 - 0.1 Mfd. Cond. 200 V. Rating
- L1 - 182 Antenna Coil S2 - 124 Tube
- L2 - 178 R.F. Coil S3-S6-S7 - 127 " "
- L3 - 179 Osc. Coil S8-S9 - 147 " "
- L4 - 281 R.F. Choke S1-S4-S5 - 151 " "
- L5 - 10145 Choke S10 - 180 " "
- R1 - 500,000 Ohm Resistor 1 Watt Carbon
- R2 - 30,000 Ohm Resistor 1 Watt Carbon
- R3 - 1/2 Megohm Tapered variable resistor
- R4 - 30,000 Ohm Resistor 1 Watt Carbon
- R5 - 120 Ohm Resistor Wire Wound
- R6 - 10,000 Ohm Resistor 1 Watt Carbon
- R7 - 10,000 Ohm Resistor 3 Watt Carbon
- R8 - 100 Ohm (1800 Ohm) 1800 Ohm tapped resistor
- R9 - 1700 Ohm
- R10 - 220 Ohm Resistor 2 Watt Carbon
- T1 - C-1 I.F. Transformer
- T2 - C-2 " " "
- T3 - C-3 " " "
- T4 - A-270 Input Transformer
- T5 - 10143 Output Transformer
- T6 - 10175 Power Transformer

MODEL Q DeLuxe

SILVER - MARSHALL, INC.

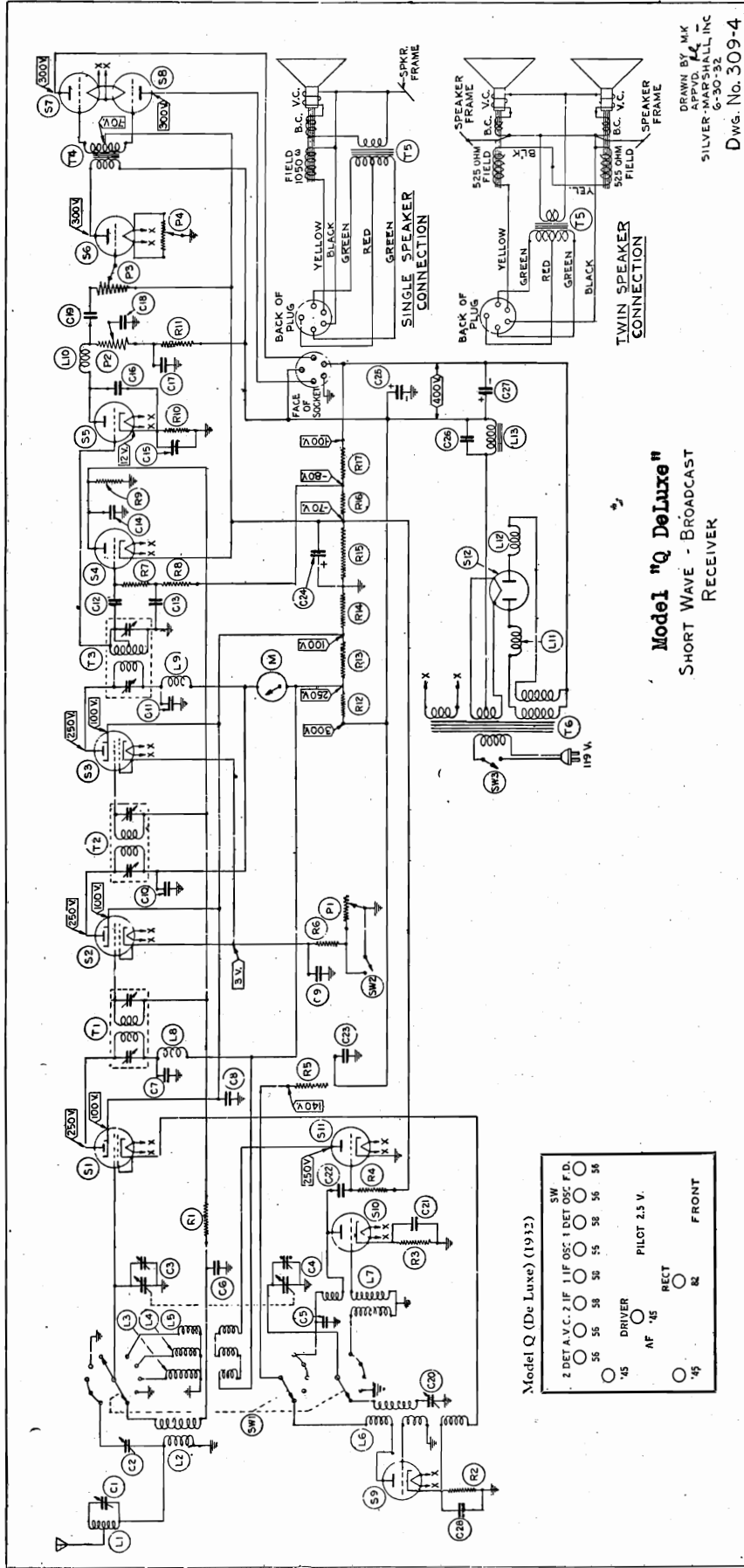

Model "Q DeLuxe"
SHORT WAVE - BROADCAST
RECEIVER

DRAWN BY M.K.
APPROVED BY
SILVER-MARSHALL, INC.
6-30-32
Dwg. No. 309-4

- Model Q (De Luxe) (1932)
- SW
 - 2 DET A.V.C. 2 IF 1 OSC. 1 DET OSC. F.D.
 - 56 56 58 58 58 55 58 58 56 56
 - DRIVER
 - AF .45
 - PILOT 2.5 V.
 - RECT
 - FRONT
 - .45

SILVER - MARSHALL, INC.

MODEL R
Parts List

MODEL "R" SUPERHETERODYNE

C1	- 48-112 mmfd. Trimmer Condenser	15275
C2-C3	- 2 gang variable Condenser - 365 mmfd. max.	13372
C4	- 4 mfd. Dry Electrolytic Condenser 450 V.	13177
C5	- .1 Mfd. Condenser 200 V.	3220
C6	- .1 Mfd. Condenser 400 V.	3173
C7	- .1 mfd. Condenser 200 V.	3220
C8	- .001 Mfd. Condenser - mica	7039
C9	- .001 Mfd. Condenser - Mica	7039
C10	- .025 Mfd. Condenser - Sprague 200 V.	3338
C11	- $\frac{1}{2}$ Mfd. Condenser - Polymet Waxtite - 200 V.	13329
C12	- .025 Mfd. Condenser - Sprague 200 V.	3333
C13	- 1 Mfd. Cond. (1, $\frac{1}{2}$, $\frac{1}{2}$, mfd. Unit)	13140
C14	- .03 Mfd. Condenser - Sprague 700 V.	13331
C15	- 75-500 Mfd. Osc. Trimmer Condenser	16179
C16	- .1 Mfd. Condenser - Sprague 200 V.	3220
C17	- .1 Mfd. Condenser - Sprague 200 V.	3220
C18	- .15 Mfd. Condenser - Sprague 200 V.	13145
C19	- $\frac{1}{2}$ Mfd. Condenser - Polymet Waxtite 200 V.	13329
C20	- .0005 Mfd. Condenser - Mica	7052
C21	- .1 Mfd. Condenser - Sprague 200 V.	3220
C22	- $\frac{1}{2}$ Mfd. Condenser (See C13)	
C23	- $\frac{1}{2}$ Mfd. Condenser (See C13)	
C24	- 8 Mfd. Dry Electrolytic Condenser 450 V.	13181
C25	- 12 Mfd. Dry Electrolytic Condenser 450 V.	3162
M	- Tuning Meter - 15 ma.	13923
P1	- 100,000 Ohm Pot. (Tone Control)	14438
P2	- 250,000 Ohm Pot. (Vol Control combined with A.C. Switch)	4360
R1	- 250 Ohm Resistor - wire wound	4725
R2	- 60,000 Ohm Resistor - 1 watt carbon	4695
R3	- 25,000 Ohm Resistor - 1 watt carbon	4697
R4	- 100,000 Ohm Resistor - 1 watt carbon	14691
R5	- 5,000 Ohm Resistor - 1 watt carbon	14765
R6	- 400 Ohm Resistor - wire wound	4701
R7	- 3,500 Ohm Resistor - 1 watt carbon	4804
R8	- 80,000 Ohm Resistor - 1 watt carbon	14778
R9	- 1 Megohm Resistor - 1 watt carbon	4759
R10	- 1 Megohm Resistor - 1 watt carbon	4759
R11	- 9,000 Ohm Resistor - 1 watt carbon	14746
R12	- 60,000 Ohm Resistor - 1 watt carbon	4695
R13	- 100,000 Ohm Resistor - 1 watt carbon	14691
R14	- 1 megohm Resistor - 1 watt carbon	4759
R15	- 8,250 Ohms)	
R16	- 6,500 ohms) 14,750 Ohm R.D. Ohmite - 3 watt.	14781
R17	- $\frac{1}{2}$ Megohm Resistor - 1 watt	4772
R18	- 12,000 Ohm Resistor - 1 watt	4748
SW1	- Change-over Switch	15327
SW2	- A.C. Switch (Combined with Vol. Control)	

MODEL P
MODEL P Battery

SIMPLEX RADIO CO.

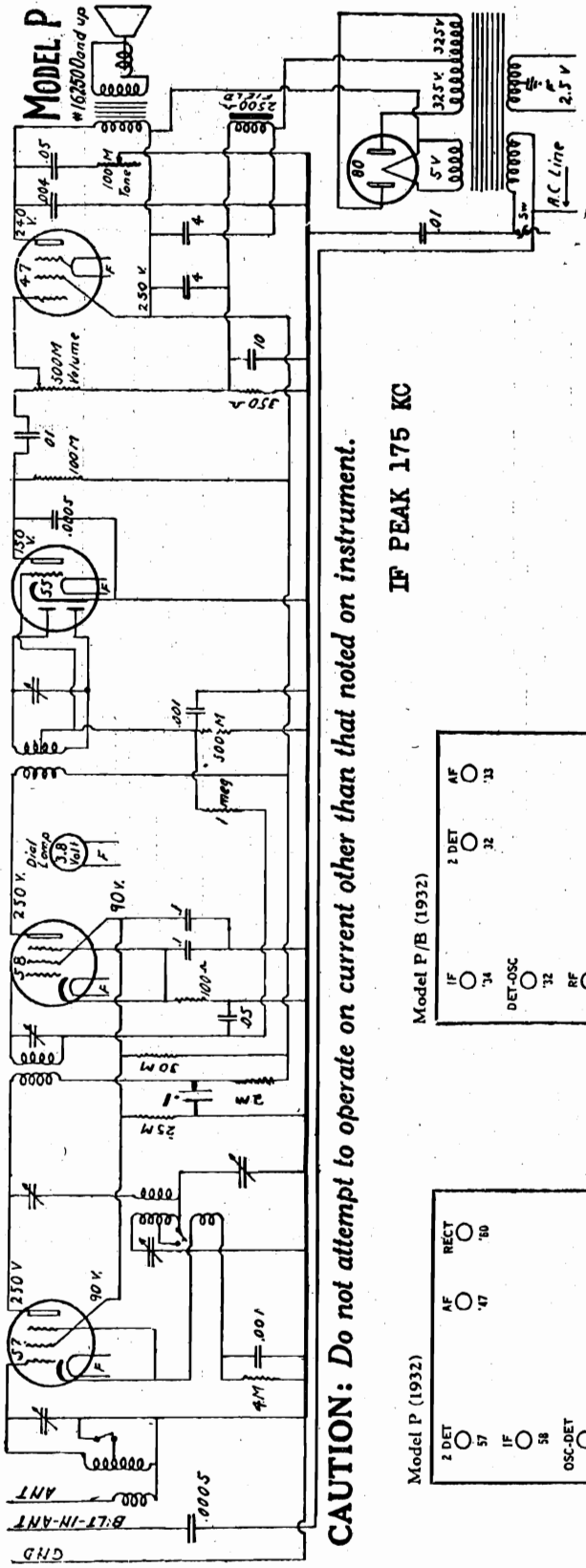

CAUTION: Do not attempt to operate on current other than that noted on instrument.

IF PEAK 175 KC

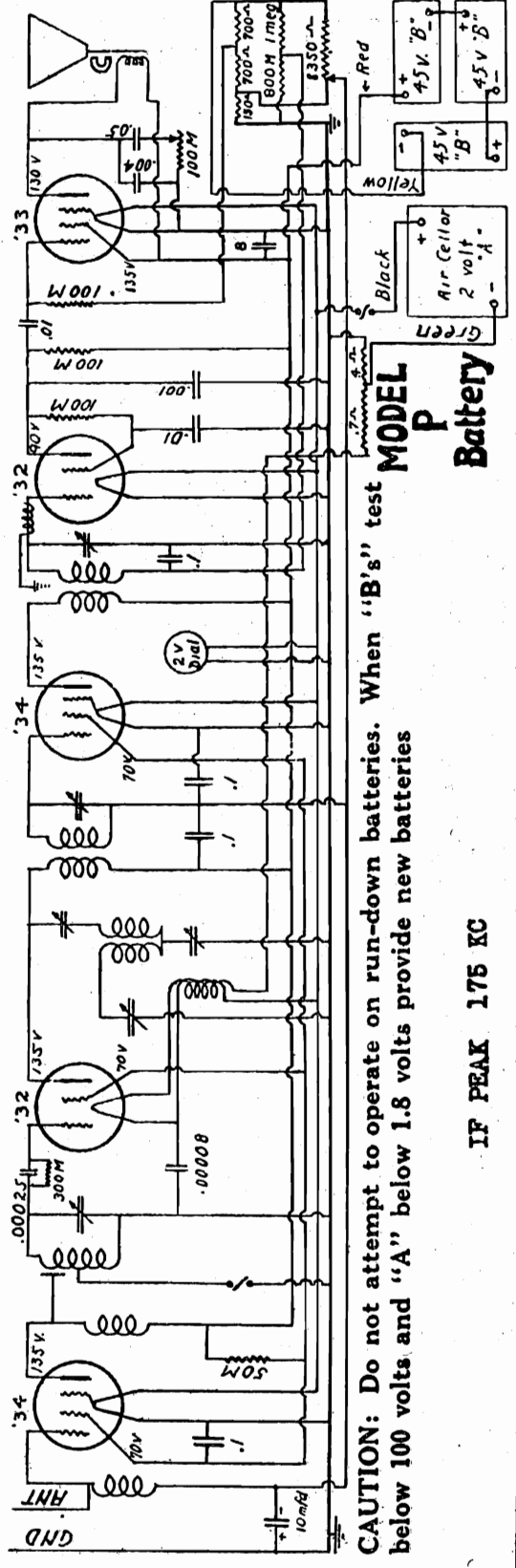
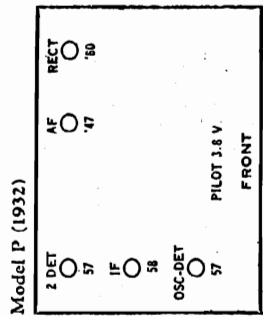
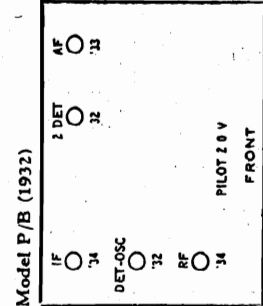

CAUTION: Do not attempt to operate on run-down batteries. When "B's" test below 100 volts and "A" below 1.8 volts provide new batteries

IF PEAK 175 KC

MODEL P Battery

MODEL 84,85
Socket
Voltage, Notes

SONORA

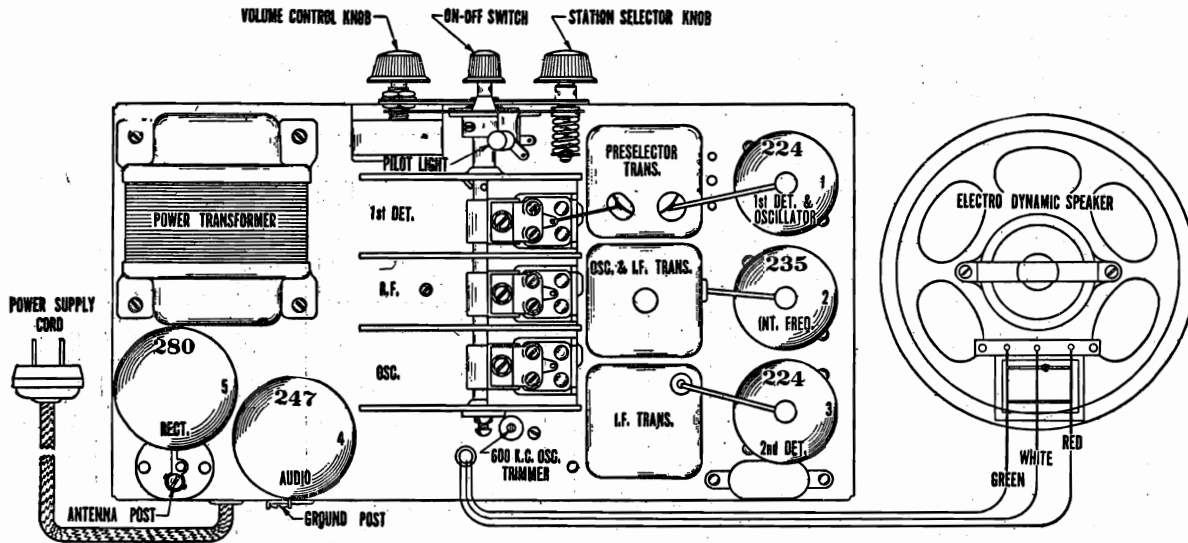

Top View of Chassis showing Tube Sequence and Speaker Connections

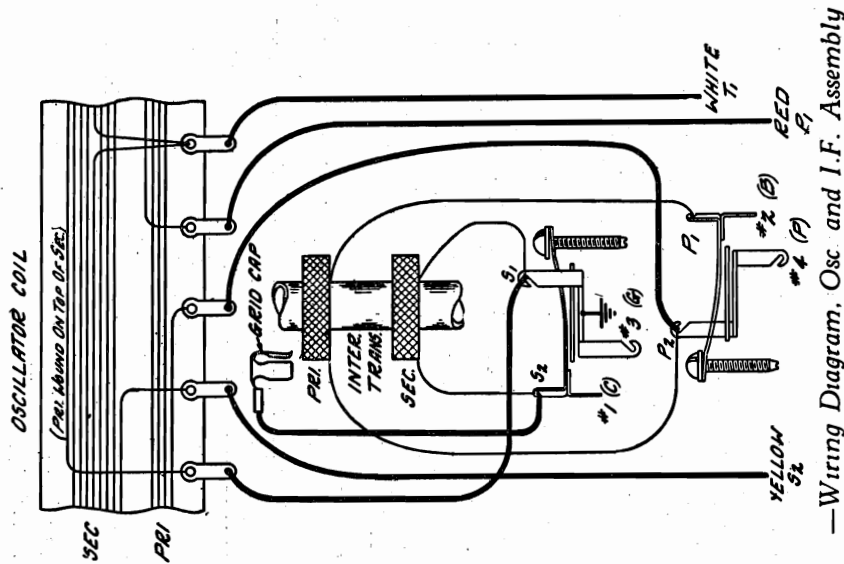

— Wiring Diagram, Osc. and I.F. Assembly

VOLTAGES AT SOCKETS
LINE VOLTAGE 115—VOLUME CONTROL AT MAXIMUM

Type of Tube	Position of Tube	Function	"A" Volts	"B" Volts	Control Grid "C" Volts	Screen Volts	Screen Current MA	Cathode Volts	Plate MA	Grid Test MA
224	1	1st Det. & Osc.	2.25	165	4.5-5.25 ⁽¹⁾	65	.4	4.5-5.25 ⁽¹⁾	1.3	2.0
235	2	I.F.	2.25	165	2.5	65	1.5	2.5	6.4	7.4
224	3	2nd Det.	2.25	128	6.5	60 ⁽²⁾	.05	6.5	.22	.23
247	4	Audio	2.25	205	16. ⁽³⁾	225	8.0		29.	33.
280	5	Rect.	4.9						27. Per Plate	

(1) Varies with frequency setting of dial approximately as shown.
 (2) Voltage as measured with 600,000 ohm meter.
 (3) Measured across 300 ohm section of voltage divider resistor.

SONORA

MODEL 84,85
Schematic

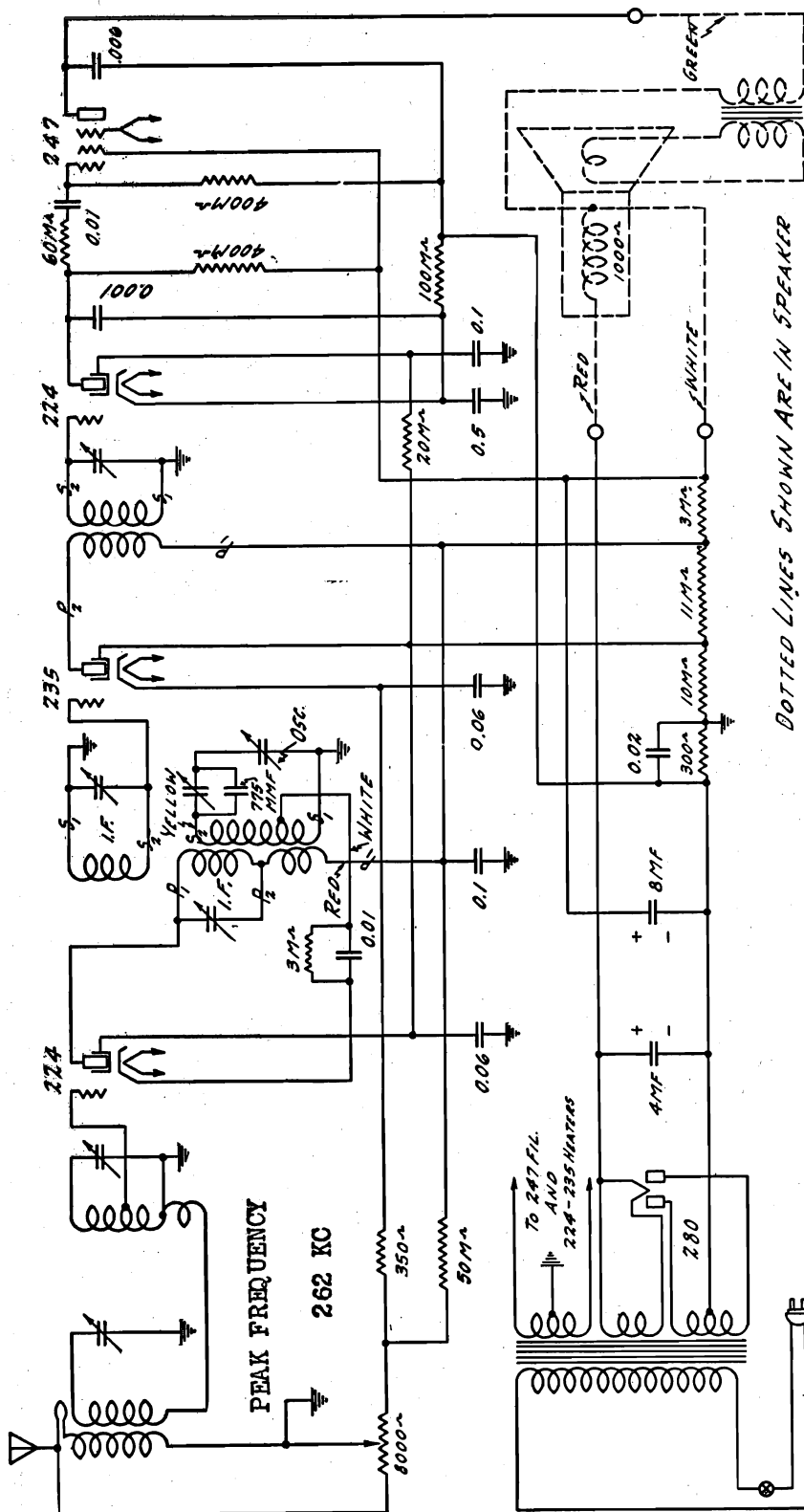

DOTTED LINES SHOWN ARE IN SPEAKER

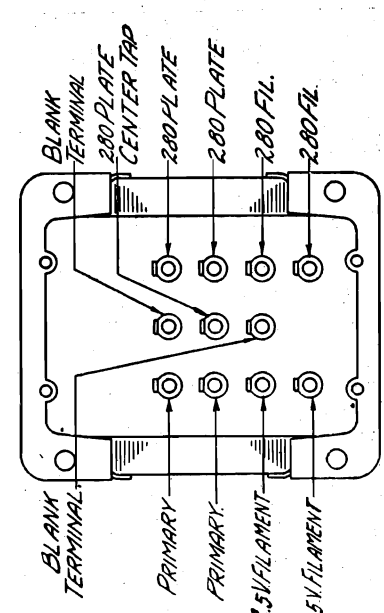

Power Transformer Terminals

There are certain features to be noted in this receiver. The mixer is of the autodyne type, wherein it functions as a mixer (1st detector) and also as an oscillator. Also that the grid lead from the mixer tube joins the grid coil at a tap upon this winding. This tap is so apportioned that the circuit acts to suppress the transmission of image frequency signals, in this case 524 KC higher than the frequency setting of the tuned circuit. The IF transformer is also of special structure combining the coupling transformer and also the oscillator system. The structure of this transformer-oscillator is illustrated upon the next page.

MODEL 86,87
Voltage
Transformer
Notes

SONORA

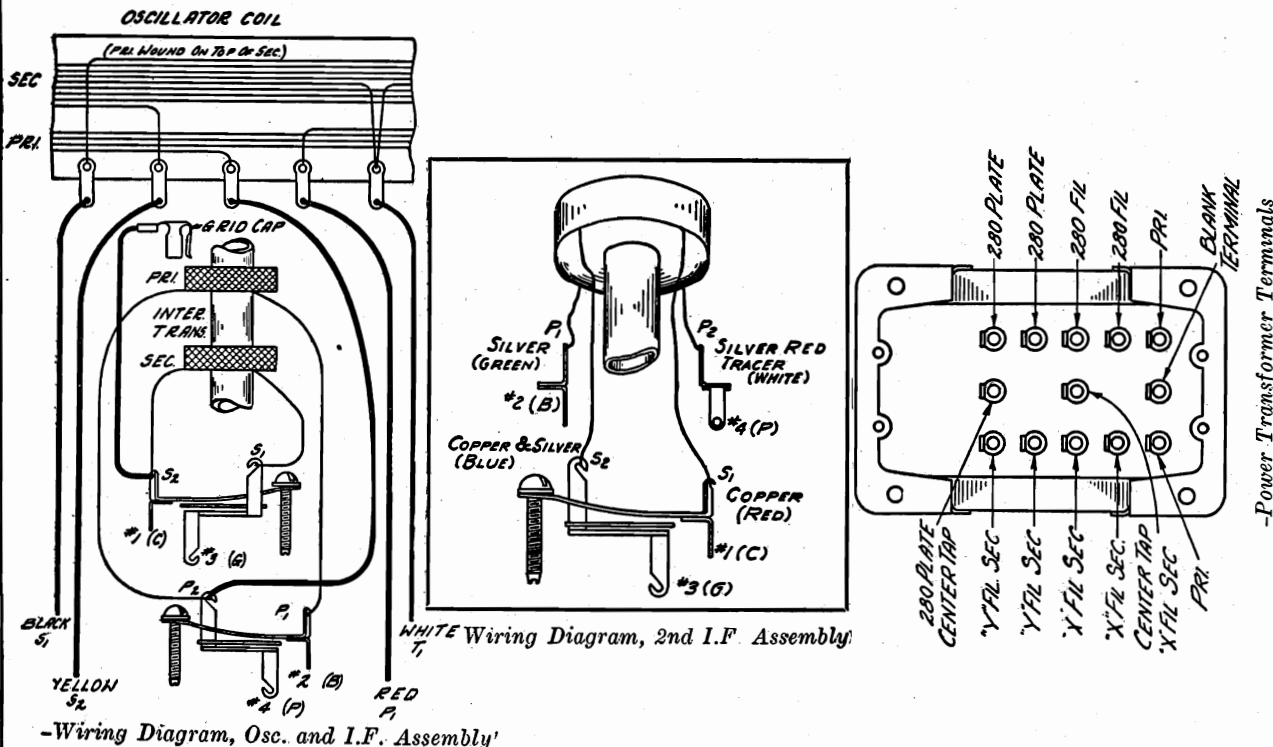

VOLTAGES AT SOCKETS—LINE VOLTAGE 115

VOLUME CONTROL AT MAXIMUM—LOCALIZER AT NORMAL SETTING

Type of Tube	Position of Tube	Function	Across Filament or Heater	Plate to Cathode	Grid to Cathode	Screen to Cathode	Screen MA	Cathode to Heater	Plate MA	Grid Test MA
235	1	R.F.	2.35	150	4.5 ⁽¹⁾	70 ⁽²⁾	.9	4.5	2.7	4.2
224	2	1st Det. & Osc.	2.35	240	6.4	93	.3	6.4	1.8	2.6
235	3	I.F.	2.35	150	4.5 ⁽¹⁾	70 ⁽²⁾	.9	4.5	2.7	4.2
227	4	2nd Det.	2.35	150	12-24 ⁽³⁾			0-10 ⁽³⁾	.2-5 ⁽³⁾	21-51 ⁽³⁾
224	5	A.V.C.	2.35	60	0-15 ⁽³⁾	9	0 ⁽⁴⁾	12	0 ⁽⁴⁾	0 ⁽⁴⁾
247	6	Power	2.35	220	16 ⁽⁵⁾	240	6.4		34	40
280	7	Rect.	4.9						39 Per Plate	

- (1) This voltage read across 800 ohm resistor.
- (2) Voltage as read with 600,000 ohm meter.
- (3) Varies with setting of localizer. Voltages read with high resistance meter
- (4) Current zero with no signal and localizer at normal position.
- (5) The voltage read across 200 ohm section of voltage divider.

SETTING THE LOCALIZER.

Turn the localizer knob counterclockwise as far as it will go. Then turn the knob one quarter turn clockwise. Next tune in a fairly strong signal and reduce the volume by means of the volume control knob on the front panel. Then turn the localizer knob to the extreme clockwise position. This will cause plate current cutoff in the RF and IF tubes. Then turn the knob slowly in a counterclockwise direction until the signal is again heard. With a slight additional turn in the same direction the signal builds up sharply to full strength and this is the correct position of the localizer setting. This adjustment should not be changed unless the set is reinstalled or the tubes are changed. Incorrect adjustment of this knob will control the action of the AVC tube in such fashion that the automatic action will commence too soon or too late.

SPARKS WITHINGTON CO.

MODEL 9-A
Schematic
Voltage

Antenna Compensating Condenser
Accessible Thru Rear Of Chassis

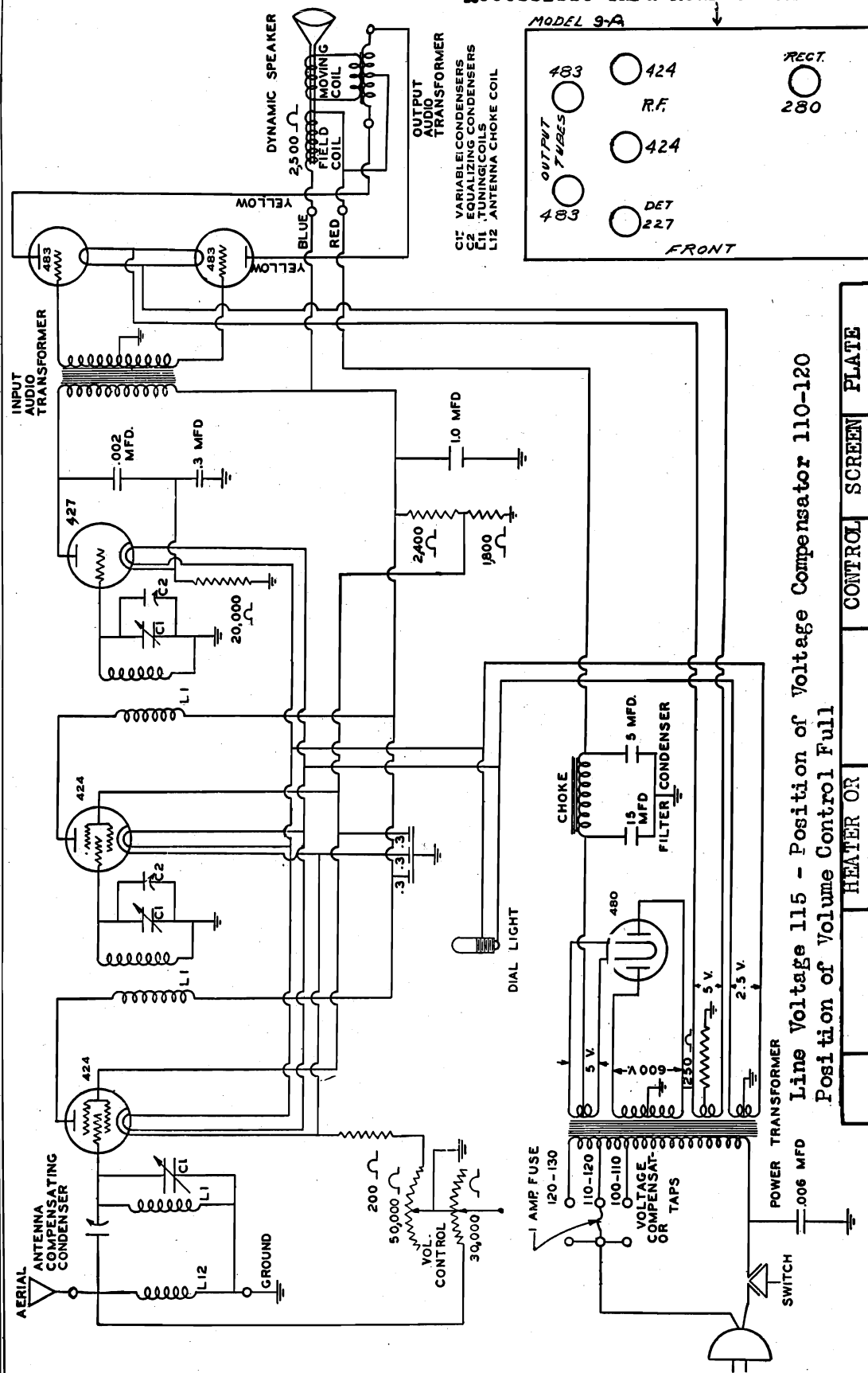

Line Voltage 115 - Position of Volume Compensator 110-120
Position of Volume Control Full

TUBE	LOCATION	HEATER OR FILAMENT	PLATE	CONTROL GRID--	SCREEN GRID+	PLATE CURRENT
424	1st R.F.	2.2 - 2.5	160 - 180	2 - 3	60 - 80	2.5 - 4
424	2nd R.F.	2.2 - 2.5	160 - 180	2 - 3	60 - 80	2.5 - 4
427	Detector	2.2 - 2.5	145 - 165	12 - 18		.4 - 1
483	Power	4.7 - 5	220 - 240	45 - 55		24. - 28
483	Power	4.7 - 5	220 - 240	45 - 55		24. - 28
480	Rectifier	4.7 - 5	320 - 340			40. - 55

SPARKS WITHINGTON CO.

MODEL 10
Chassis, Voltage

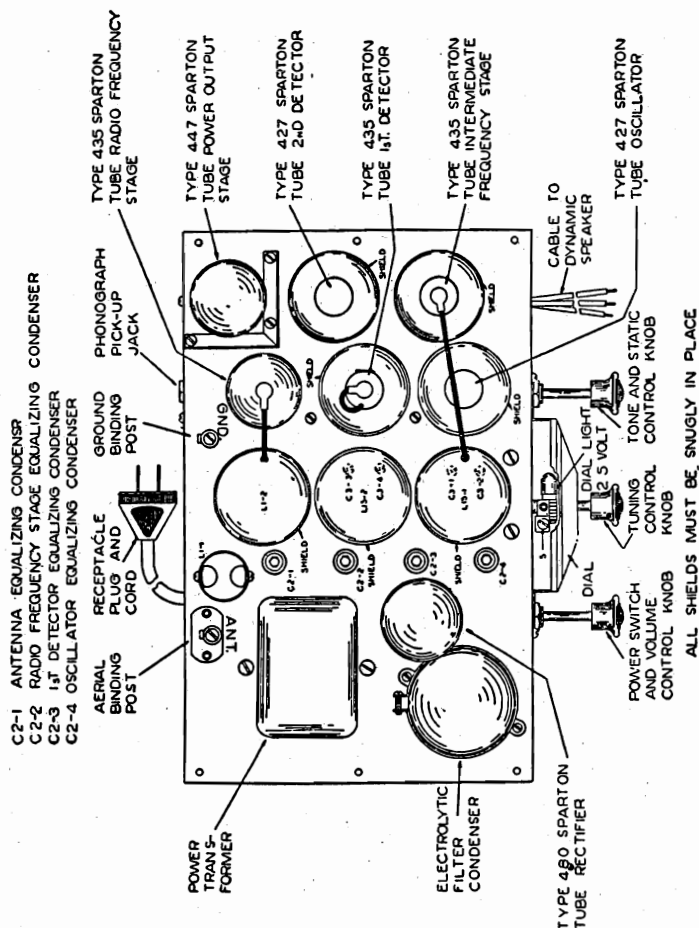

TOP VIEW MODEL 10 SUPERHETERODYNE CHASSIS

- L1-1 First R. F. Tuning Coil
- L1-2 Second R. F. Tuning Coil
- L15-1 First I. F. Transformer (1st. Det. to I.F. Stage)
- L15-2 Second I. F. Transformer (I.F. to 2nd. Det. Stage)
- C3-1 I. F. Stage First Adjustable Condenser
- C3-2 I. F. Stage Second Adjustable Condenser
- C3-3 I. F. Stage Third Adjustable Condenser
- C3-4 I. F. Stage Fourth Adjustable Condenser

Voltage-Current Characteristics

Line Voltage 115—Position of Voltage Compensator 100-115—Position of Volume Control Full

Tube	Location	OPERATING VOLTAGES				Plate Current Mills.
		Heater or Filament	Plate	Control Grid -	Screen Grid +	
435	1st R. F.	2.2 - 2.5	230 - 270	2.5 - 4.0	85 - 100	5 - 8
435	1st Det.	2.2 - 2.5	230 - 270	**4.5 - 7.5	85 - 110	**1.8 - 3.5
435	1st I. F.	2.2 - 2.5	230 - 270	2.5 - 4.0	85 - 110	5 - 8
427	Oscillator	2.2 - 2.5	85 - 110	†	-----	‡
427	2nd Det.	2.2 - 2.5	*100 - 135	8 - 14	-----	4.0 - .7
447	Power	2.2 - 2.5	220 - 260	15 - 18	-----	30 - 36
480	Rectifier	4.2 - 5	360 - 420	-----	-----	40 - 55

*Use 300 volt scale. †Tube generates own bias when oscillating.
 **Remove Oscillator tube. ‡Test with plug in 2nd. Detector socket and tube in analyzer

MODEL 10
Schematic

SPARKS WITHINGTON CO.

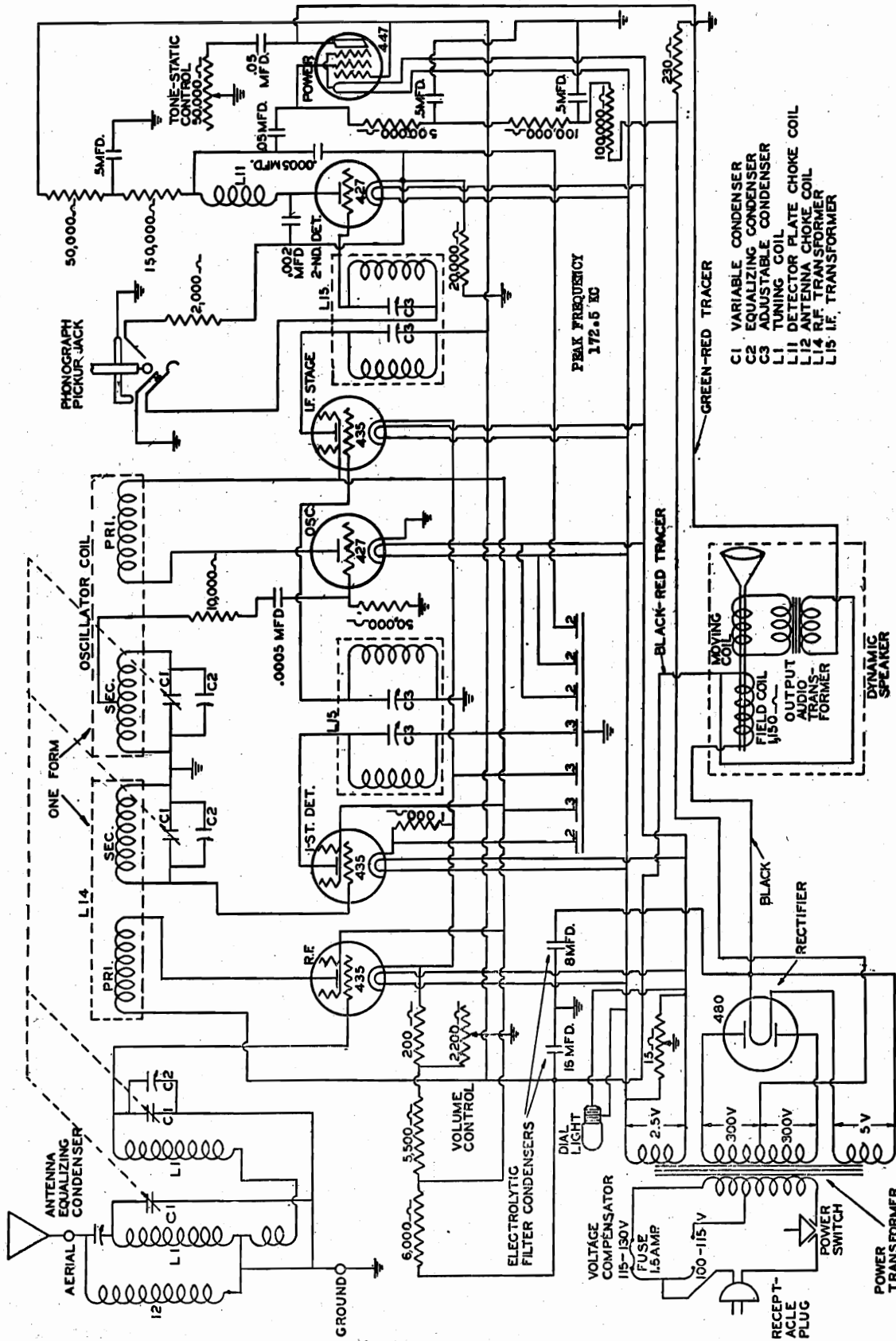

- C1 VARIABLE CONDENSER
- C2 EQUALIZING CONDENSER
- C3 ADJUSTABLE CONDENSER
- L1 TUNING COIL
- L11 DETECTOR PLATE CHOKE COIL
- L12 ANTENNA CHOKE COIL
- L14 RF TRANSFORMER
- L15 IF TRANSFORMER

IF PEAK 172.5 KC

MODEL 12
Schematic
Chassis, Voltage

SPARKS WITHINGTON CO.

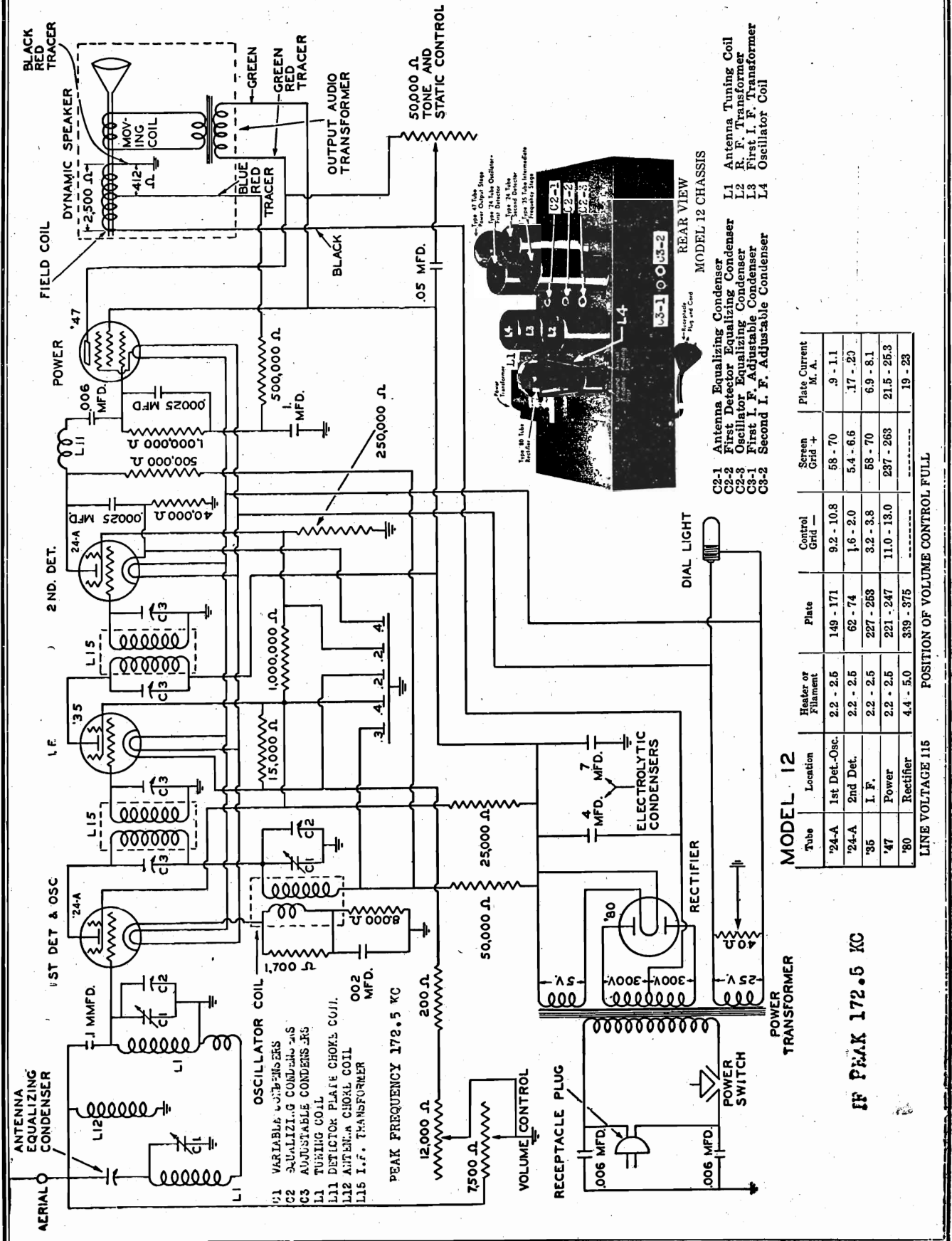

MODEL 12

Tube	Location	Heater or Filament	Plate	Control Grid -	Screen Grid +	Plate Current M. A.
'24-A	1st Det.-Osc.	2.2 - 2.5	149 - 171	9.2 - 10.8	68 - 70	.9 - 1.1
'24-A	2nd Det.	2.2 - 2.5	62 - 74	1.6 - 2.0	5.4 - 6.6	.17 - .20
'35	I. F.	2.2 - 2.5	227 - 253	3.2 - 3.8	58 - 70	6.9 - 8.1
'47	Power	2.2 - 2.5	221 - 247	11.0 - 13.0	237 - 263	21.5 - 25.3
'80	Rectifier	4.4 - 5.0	339 - 375			19 - 23

LINE VOLTAGE 115 POSITION OF VOLUME CONTROL FULL

IF PHASE 172.5 KC

MODEL 14
Chassis, Voltage

SPARKS WITHINGTON CO.

Sparton Model 14 Super-Heterodyne Schematic Diagram and Voltage Analysis

VOLTAGE ANALYSIS

Line Voltage 115—Position of Voltage Compensator 100-115—Position of Volume Control Full

Tube	Location	Heater or Filament	Plate	Control Grid —	Screen Grid +	Plate Current M. A
58	R. F. Stage	2.2—2.5	218—242	2—4	95—105	5.5—7.0
'24	1st Det.-Osc.	2.2—2.5	218—242	—	95—105	0.7—8.0
58	I. F. Stage	2.2—2.5	218—242	2—4	95—105	5.5—7.0
56	2nd Det.-AVC	2.2—2.5	*	*	—	*
56	2nd Det.-AVC	2.2—2.5	*	*	—	*
56	A. F. Stage	2.2—2.5	20—40	Zero	—	0.5—0.7
'47	Power Stage	2.2—2.5	205—225	†18—20	218—242	20—24
'80	Rectifier	4.5—5.0	315—345	—	—	19—23 per Plate

* Present only when signal is applied.
† Measured from tap on field coil to ground.

MODEL 14 CHASSIS

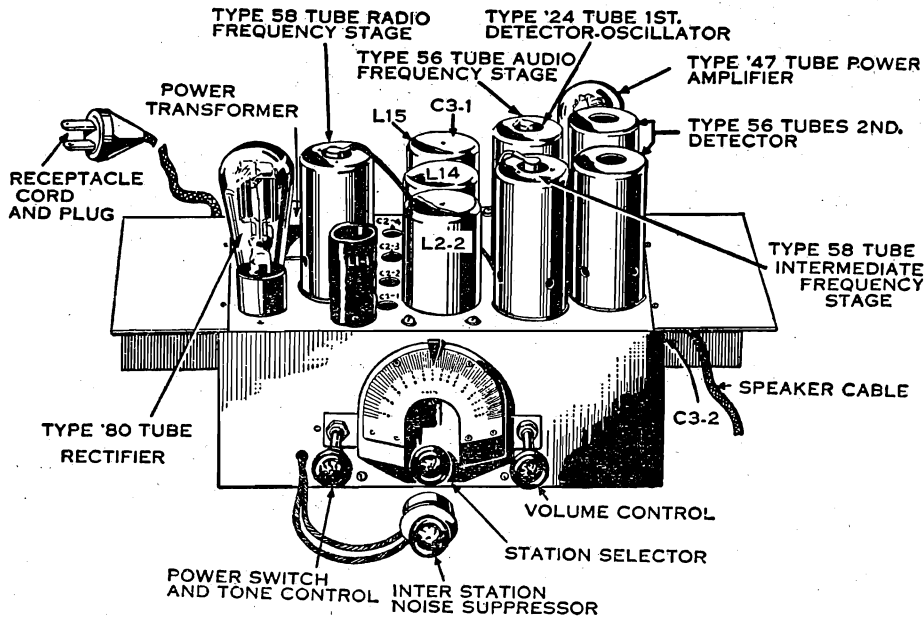

- C2-1 Antenna Equalizing Condenser
- C2-2 R. F. Stage Equalizing Condenser
- C2-3 1st Detector Equalizing Condenser
- C2-4 Oscillator Equalizing Condenser
- C3-1 I. F. Input Stage Adjustable Condenser

- C3-2 I. F. Output Stage Adjustable Condenser
- L1 1st Tuning Coil
- L2 Second Tuning Coil
- L14 R. F. Transformer
- L15 I. F. Transformer

SPARKS WITHINGTON CO.

MODEL 14
Schematic

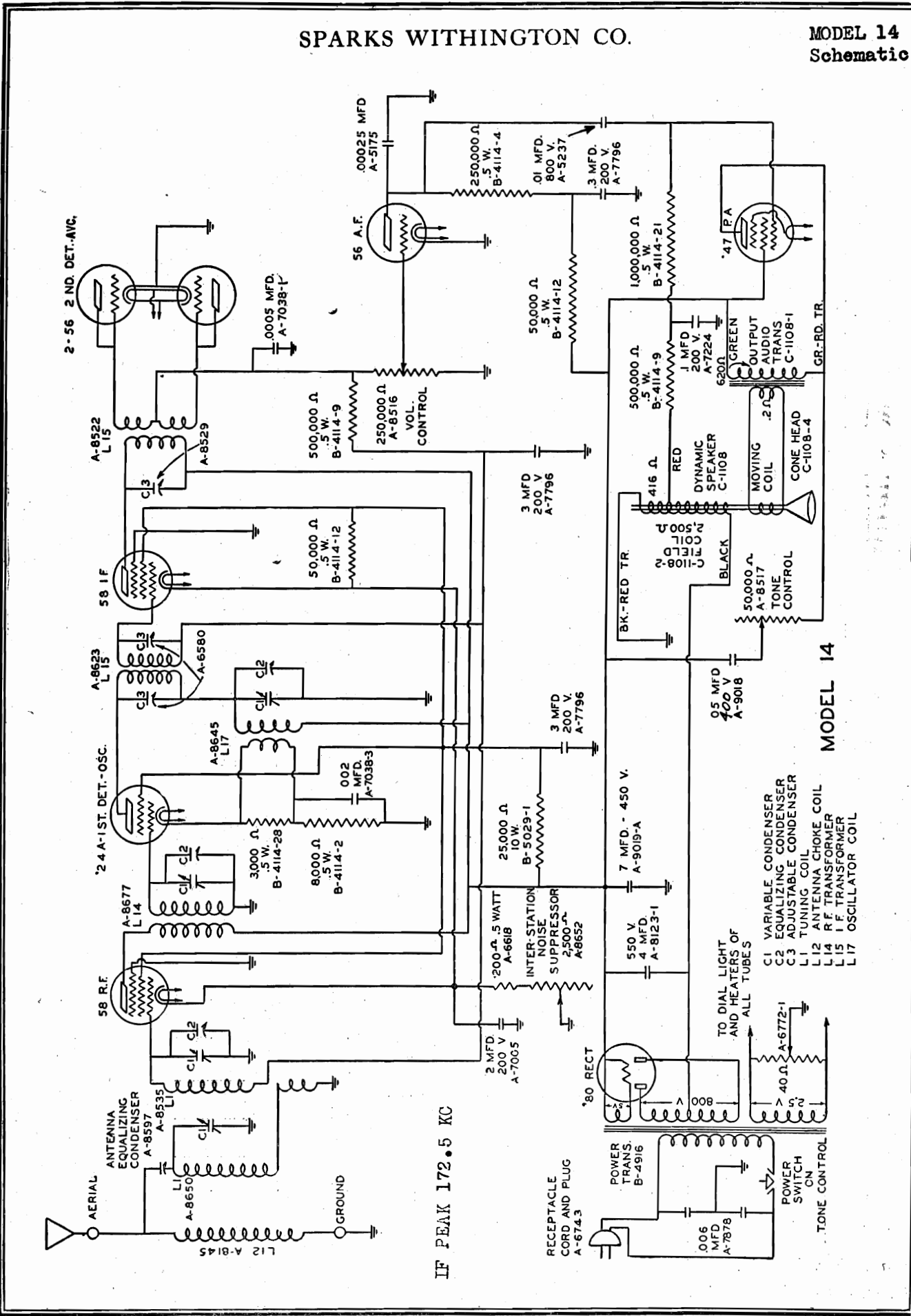

IF PEAK 172.5 KC

MODEL 14

MODEL 15

Chassis, Voltage

SPARKS WITHINGTON CO.

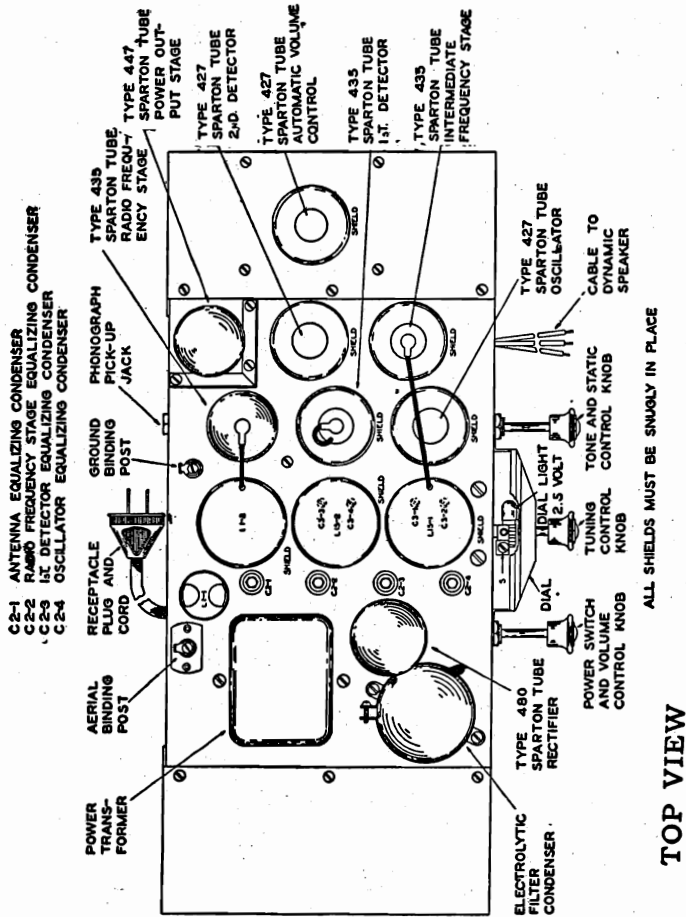

TOP VIEW

- L1-1 First R. F. Tuning Coil
- L1-2 Second R. F. Tuning Coil
- L15-1 First I. F. Transformer (1st. Det. to I. F. Stage)
- L15-2 Second I. F. Transformer (I. F. to 2nd. Det. Stage)
- C3-1 I. F. Stage First Adjustable Condenser
- C3-2 I. F. Stage Second Adjustable Condenser
- C3-3 I. F. Stage Third Adjustable Condenser
- C3-4 I. F. Stage Fourth Adjustable Condenser

Voltage-Current Characteristics

Line Voltage 115—Position of Voltage Compensator 115-130—Position of Volume Control Full

Tube	Location	OPERATING VOLTAGES				Plate Current Mills.
		Heater or Filament	Plate	Control Grid—	Screen Grid+	
435	1st R. F.	2.2 - 2.5	155 - 185	2 - 3	70 - 100	3 - 6
435	1st Det.	2.2 - 2.5	150 - 180	§ 7 - 11	70 - 100	§ 1.8 - 3
435	1st I. F.	2.2 - 2.5	155 - 185	2 - 3	70 - 100	3 - 6
427	Oscillator	2.2 - 2.5	70 - 95	†	‡
427	2nd Det.	2.2 - 2.5	*100 - 135	8 - 14	4.0 - .7
427	A. V. C.	2.2 - 2.5	30 - 40	24	Zero
427	Power	2.2 - 2.5	220 - 260	15 - 18	230 - 270	30 - 36
480	Rectifier	4.2 - 5	320 - 370	40 - 55

* Use 300 volt scale.

† Tube generates own bias when oscillating.

§ Remove Oscillator tube.

‡ Test with plug in 2nd. Detector socket and tube in analyzer.

SPARKS WITHINGTON CO.

MODEL 15 Schematic

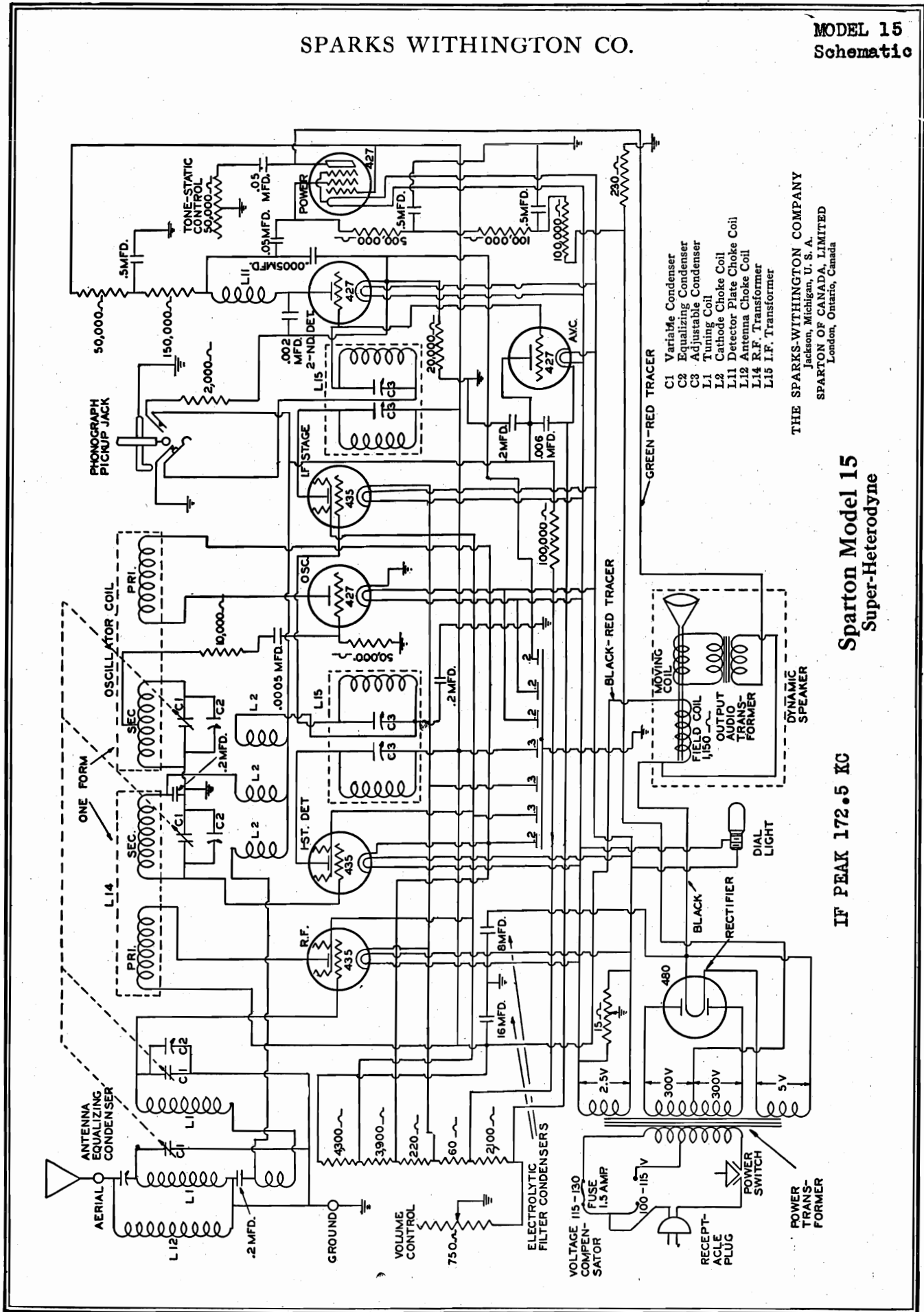

- C1 Variable Condenser
- C2 Equalizing Condenser
- C3 Adjustable Condenser
- L1 Tuning Coil
- L2 Cathode Choke Coil
- L11 Detector Plate Choke Coil
- L12 Antenna Choke Coil
- L14 R.F. Transformer
- L15 I.F. Transformer

THE SPARKS-WITHINGTON COMPANY
 Jackson, Michigan, U. S. A.
 SPARTON OF CANADA, LIMITED
 London, Ontario, Canada

Sparton Model 15
Super-Heterodyne

IF PEAK 172.5 KC

MODEL 16-AW, 26-AW
Short-Wave Receiver
Schematic, Voltage

SPARKS WITHINGTON CO.

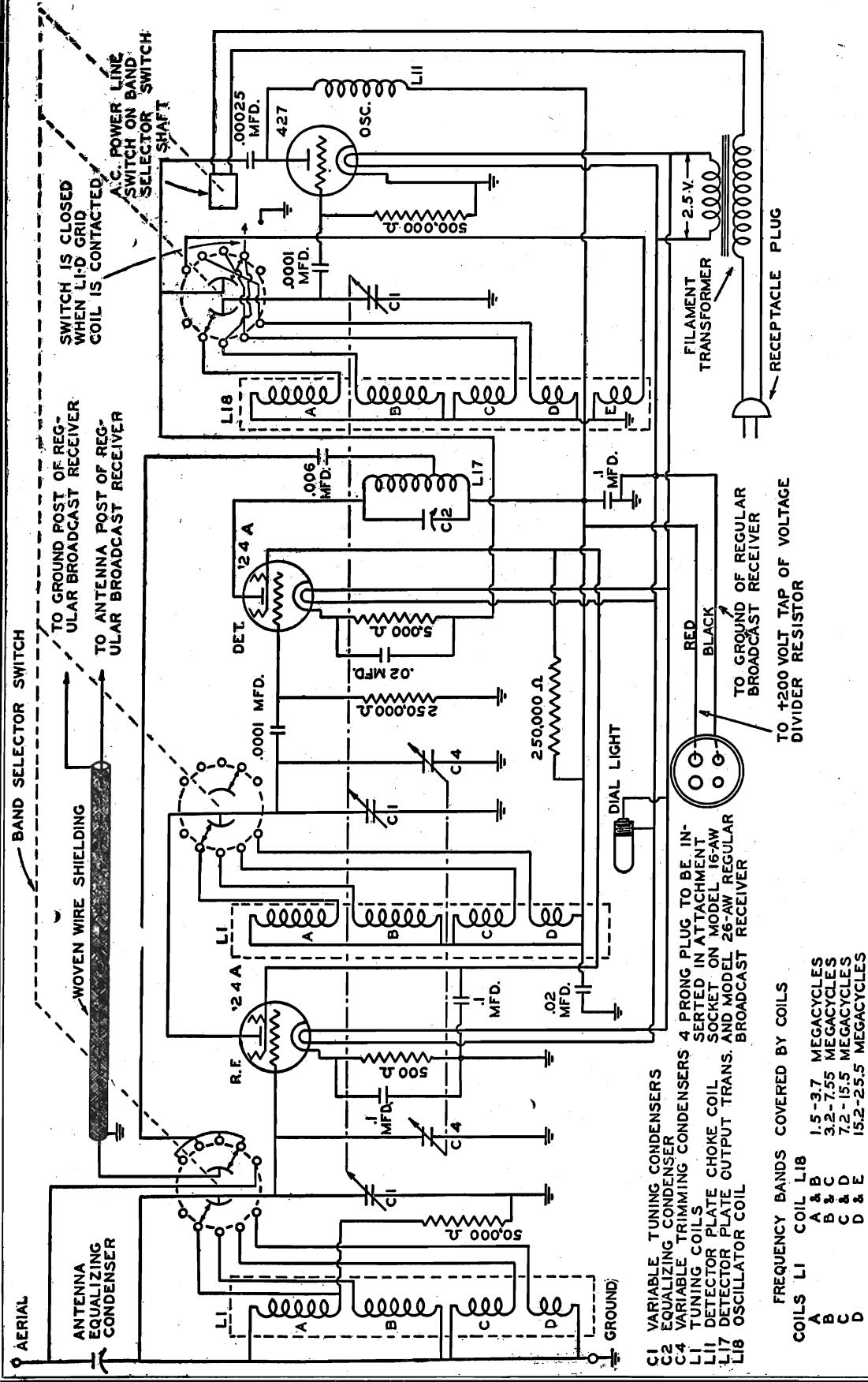

- C1 VARIABLE TUNING CONDENSERS
- C2 EQUALIZING CONDENSER
- C4 VARIABLE TRIMMING CONDENSERS
- L1 TUNING COILS
- L11 DETECTOR PLATE CHOKE COIL
- L17 DETECTOR PLATE OUTPUT TRANS.
- L18 OSCILLATOR COIL

- FREQUENCY BANDS COVERED BY COILS
- | COILS | L1 | L18 |
|-------|-----------|------------|
| A | 1.5-3.7 | MEGACYCLES |
| B | 3.2-7.55 | MEGACYCLES |
| C | 7.2-15.5 | MEGACYCLES |
| D | 15.2-25.5 | MEGACYCLES |

MODEL 16-AW SHORT-WAVE UNIT

24-A	R. F.	2.2 - 2.5	280 - 280	2 - 3	70 - 100	3.0 - 6.0
24-A	Detector	2.2 - 2.5	280 - 280	15 - 6	70 - 100	0.2 - 1.0
427	Oscillator	2.2 - 2.5	280 - 280	†	---	x

* True value. Amount is less if measured on test kit.
 † True value. Amount is more if measured on test kit.
 ‡ Measure with plug in second detector socket and tube in test kit.
 § Presence of voltage can only be determined by testing circuit continuity and measuring the plate and screen grid current of this tube. Voltage is five thousand times current in amperes.

MODEL 26-AW SHORT-WAVE UNIT

24-A	R. F.	2.2 - 2.4	170 - 200	2 - 3	70 - 100	3 - 6
24-A	Detector	2.2 - 2.4 <td>170 - 200 <td>15 - 6 <td>70 - 100 <td>0.2 - 1</td> </td></td></td>	170 - 200 <td>15 - 6 <td>70 - 100 <td>0.2 - 1</td> </td></td>	15 - 6 <td>70 - 100 <td>0.2 - 1</td> </td>	70 - 100 <td>0.2 - 1</td>	0.2 - 1
427	Oscillator	2.2 - 2.4 <td>170 - 200 <td>†</td> <td>---</td> <td>x</td> </td>	170 - 200 <td>†</td> <td>---</td> <td>x</td>	†	---	x

* Remove oscillator Tube
 † Tube generates own bias when oscillating.
 ‡ Presence of voltage can only be determined by testing circuit continuity and measuring the plate and screen grid current of this tube. Voltage is five thousand times current in amperes.
 § Measure with plug in second detector socket and tube in test kit.
 † True value. Amount is more if measured on test kit.
 ‡ Meter reading on 150 volt scale. True voltage 60-75. If 150 volt scale is used extract lower voltage

SPARKS WITHINGTON CO.

MODEL 16, 16-AW
Broadcast Receiver
Schematic, Voltage

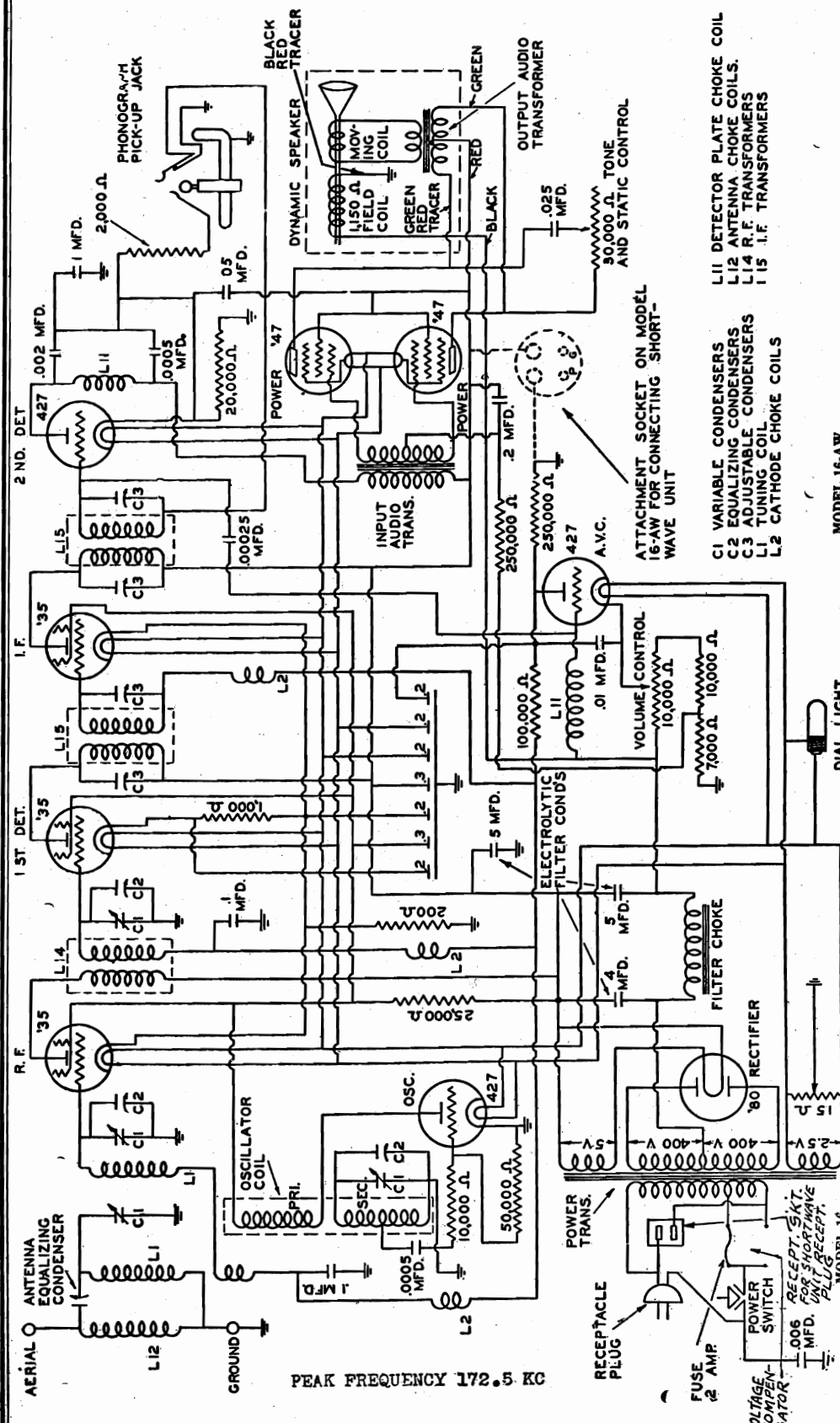

PEAK FREQUENCY 172.5 KC

- L11 DETECTOR PLATE CHOKE COIL
- L12 ANTENNA CHOKE COILS.
- L14 R.F. TRANSFORMERS
- L1 TUNING COIL
- L2 CATHODE CHOKE COILS
- C1 VARIABLE CONDENSERS
- C2 EQUALIZING CONDENSERS
- C3 ADJUSTABLE CONDENSERS

MODEL 16-AW

Line Voltage 115	Position of Voltage Compensator 115-130	Position of Volume Control Full						
Tube	Location	Heater or Filament	Plate	Control Grid -	Control Grid +	Screen Grid -	Screen Grid +	Plate Current M. A.
'35	R. F.	2.2 - 2.5	250 - 280	2 - 3	80 - 100	3.5 - 6.0		
'35	1st Det.	2.2 - 2.5	245 - 275	*4 - 6	80 - 100	2.7 - 3.1		
'35	I. F.	2.2 - 2.5	250 - 280	2 - 3	80 - 100	3.5 - 6.0		
427	Oscillator	2.2 - 2.5	70 - 100	†	-----	13.0 - 5.0		
427	2nd Det.	2.2 - 2.5	230 - 250	18 - 23	-----	0.8 - 1.2		
427	A. V. C.	2.2 - 2.5	25 - 35	27 - 35	-----	Zero		
'47	Power	2.2 - 2.5	240 - 275	17 - 20	250 - 280	20 - 28		
'47	Power	2.2 - 2.5	240 - 275	17 - 20	250 - 280	20 - 28		
'80	Rectifier	4.4 - 5.0	360 - 410	-----	-----	-----	-----	38 - 48

MODEL 16

Line Voltage 115	Position of Voltage Compensator 115-130	Position of Volume Control Full						
Tube	Location	Heater or Filament	Plate	Control Grid -	Control Grid +	Screen Grid -	Screen Grid +	Plate Current M. A.
'35	R. F.	2.2 - 2.5	255 - 285	2 - 3	80 - 100	3.5 - 6.0		
'35	1st Det.	2.2 - 2.5	245 - 275	*4 - 6	80 - 100	2.7 - 3.1		
'35	I. F.	2.2 - 2.5	255 - 285	2 - 3	80 - 100	3.5 - 6.0		
427	Oscillator	2.2 - 2.5	70 - 100	†	-----	13.0 - 5.0		
427	2nd Det.	2.2 - 2.5	235 - 265	18 - 23	-----	0.8 - 1.2		
427	A. V. C.	2.2 - 2.5	25 - 35	27 - 35	-----	Zero		
'47	Power	2.2 - 2.5	245 - 275	17 - 20	255 - 285	20 - 28		
'47	Power	2.2 - 2.5	245 - 275	17 - 20	255 - 285	20 - 28		
'80	Rectifier	4.4 - 5.0	360 - 410	-----	-----	-----	-----	35 - 45

MODEL AR-19
MODEL AR-50
Chassis

SPARKS WITHINGTON CO.

Top View—Models AR-19 and AR-50 Receiving Units

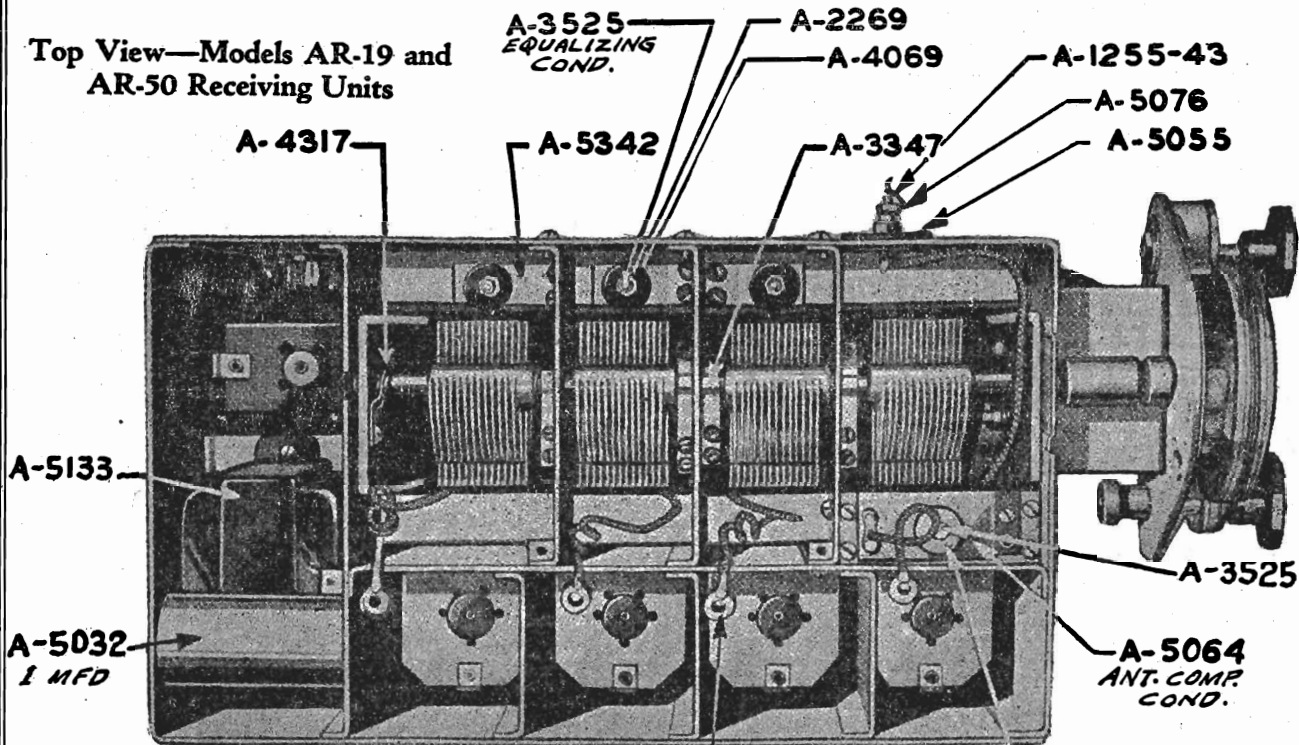

NOTE: Model AR-50 does not employ variable condensers, and the volume control and switch is mounted on steering column.

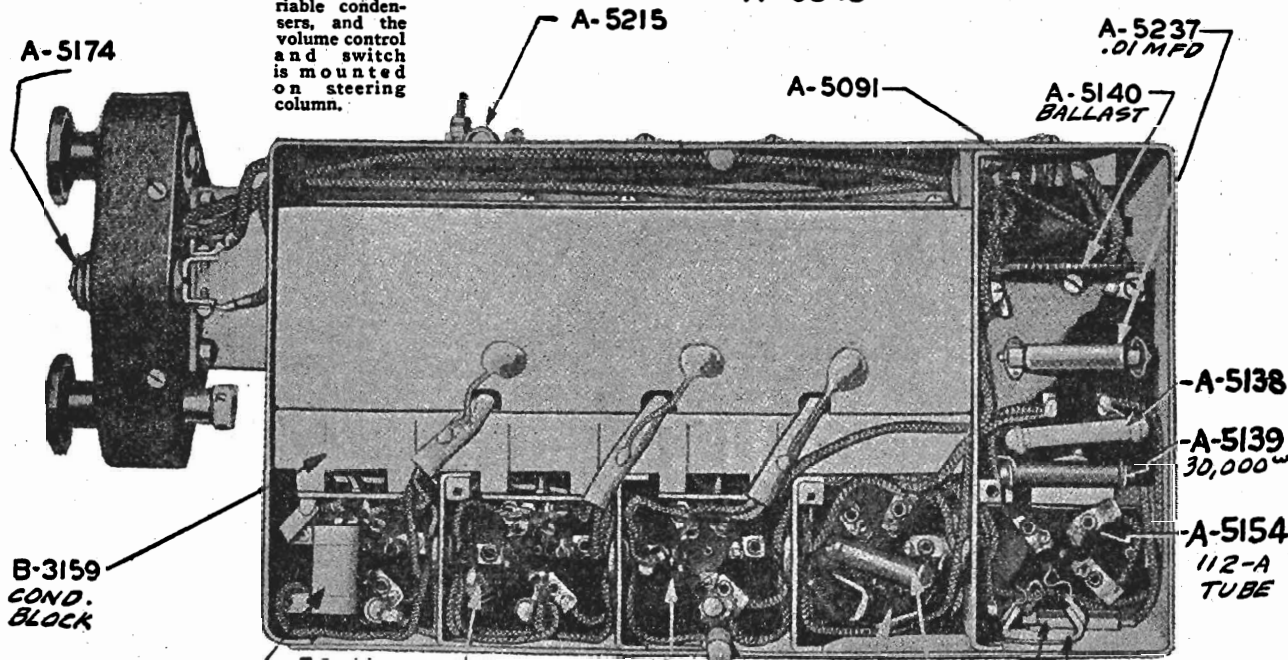

Bottom View
Models AR-19 and AR-50 Receiving Units

NOTE: In Model AR-50, A-5139 resistor is replaced with A-4261 resistor; A-5174 key switch is replaced with A-5903 toggle switch.

PART #A5217 FOR SPARK PLUG=.01 MFD
PART #A5238 FOR GENERATOR=.01 MFD

A-5175
.00025 MFD.

A-5210
CHOKE (DET.)

SPARKS WITHINGTON CO.

MODEL AR-19
MODEL AR-50
Schematic

MODEL A.R.-19

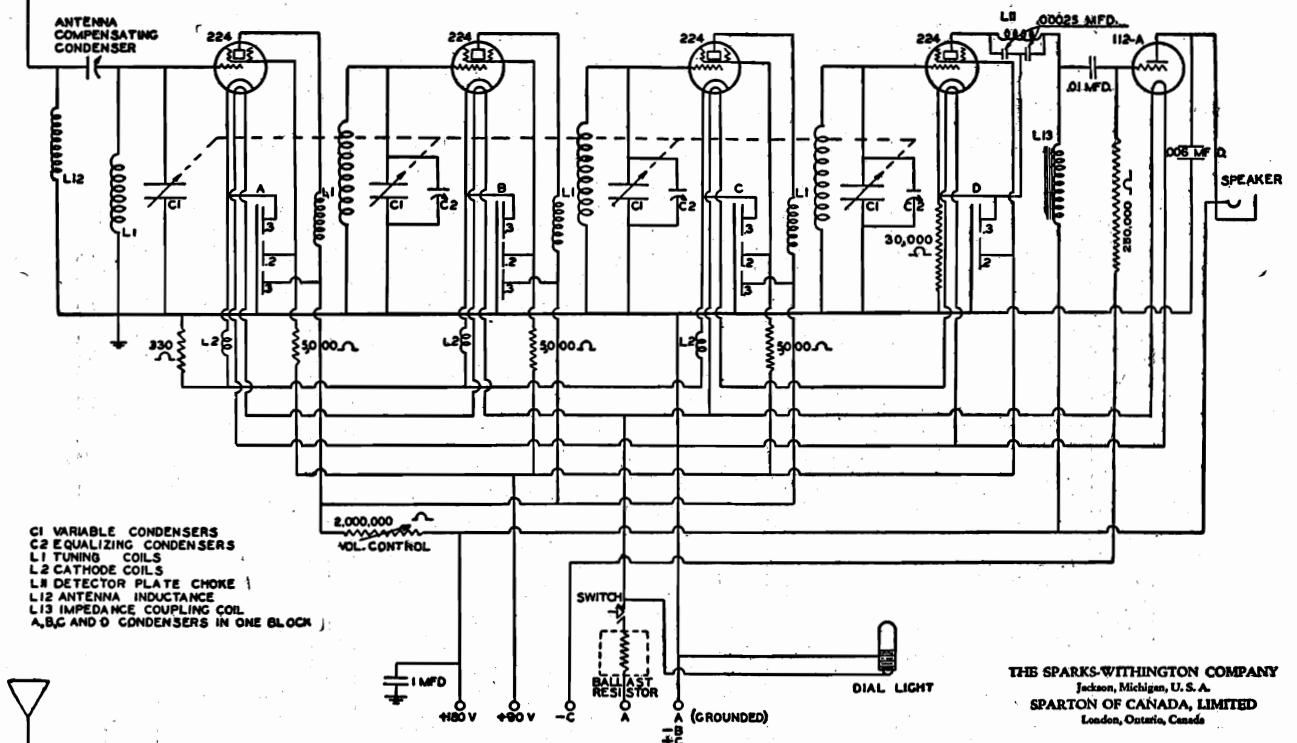

MODEL AR-50 POLICE AUTOMOBILE RADIO

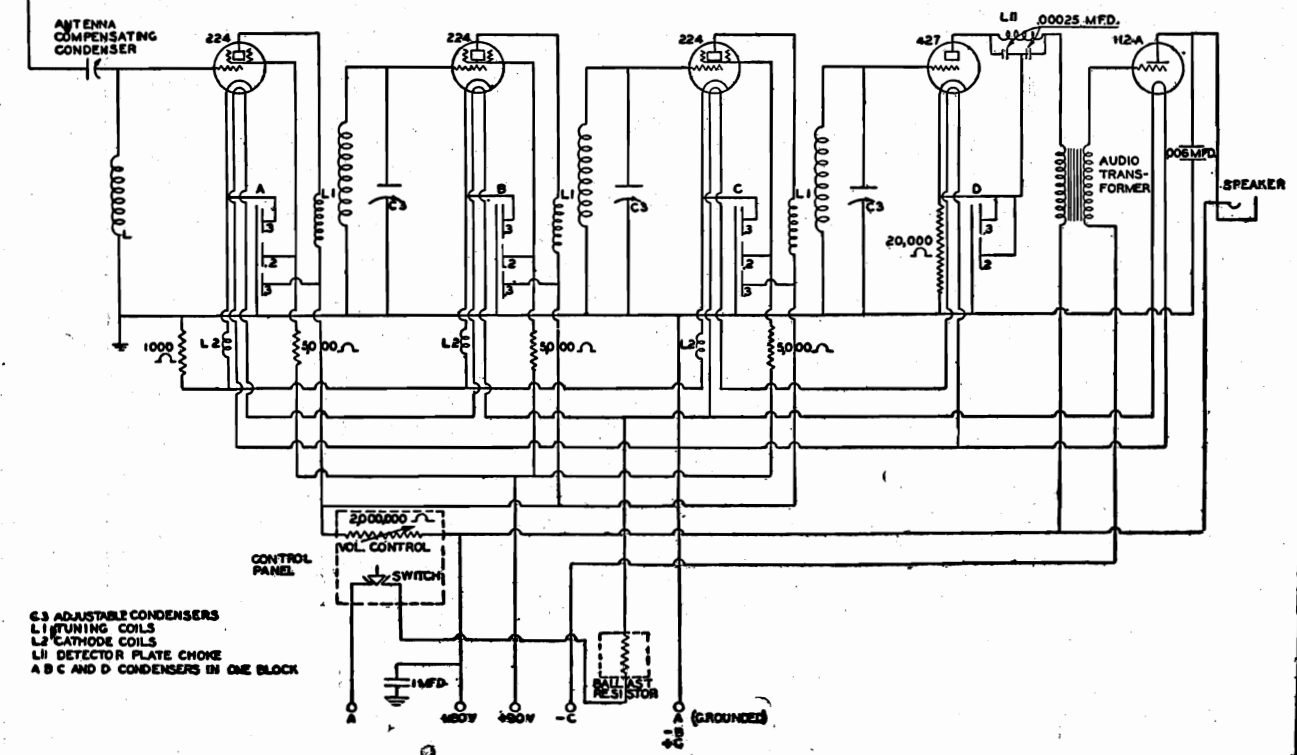

MODEL 25,26
Schematic

SPARKS WITHINGTON CO.

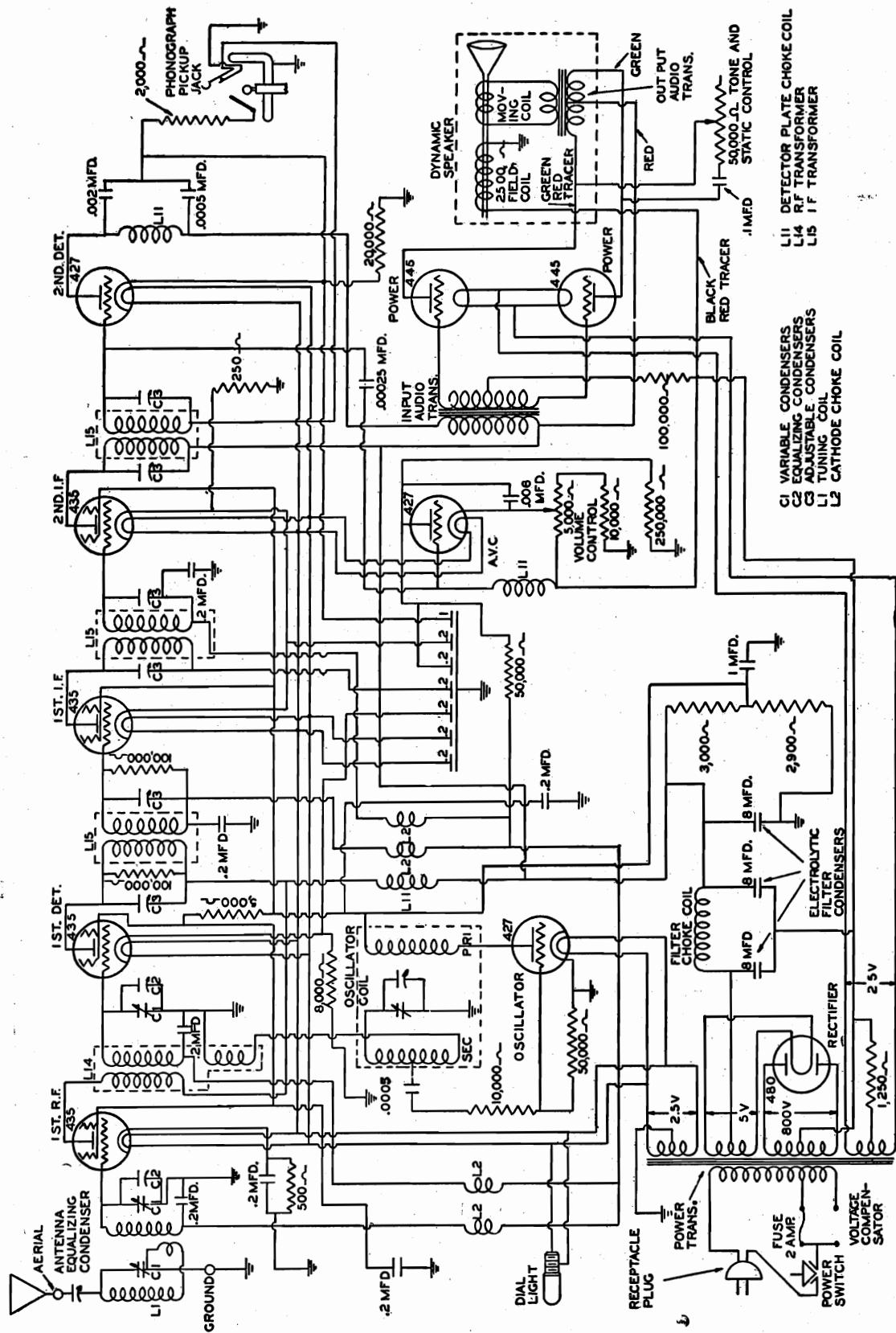

- C1 VARIABLE CONDENSERS
- C2 EQUALIZING CONDENSERS
- C3 ADJUSTABLE CONDENSERS
- L1 TUNING COIL
- L2 CATHODE CHOKE COIL
- L11 DETECTOR PLATE CHOKE COIL
- L14 RF TRANSFORMER
- L15 IF TRANSFORMER

IF PEAK 172.5 KC

SPARKS WITHINGTON CO

MODEL 25,26
Chassis, Voltage

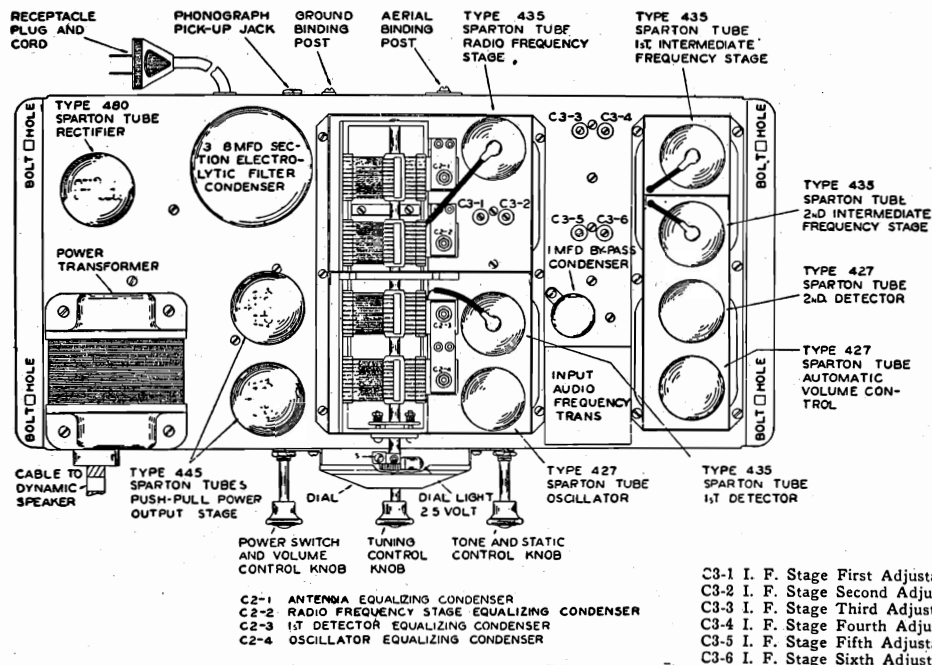

TOP VIEW OF MODEL 25 AND 26 CHASSIS

Voltage-Current Characteristics

Line Voltage 115—Position of Voltage Compensator 100-115—Position of Volume Control Full

Tube	Location	OPERATING VOLTAGES				Plate Current Mills.
		Heater or Filament	Plate	Control Grid—	Screen Grid+	
435	1st R. F.	2.2 - 2.5	180 - 220	2.5 - 4	80 - 100	5 - 8
435	1st Det.	2.2 - 2.5	180 - 220	*6.4 - 14	80 - 100	*8 - 1.8
435	1st I. F.	2.2 - 2.5	180 - 220	2.5 - 4	80 - 100	5 - 8
435	2nd I. F.	2.2 - 2.5	180 - 220	2.5 - 4	80 - 100	5 - 8
427	Oscillator	2.2 - 2.5	80 - 100	†	‡
427	2nd Det.	2.2 - 2.5	170 - 205	14 - 207 - 1.0
427	A. V. C.	2.2 - 2.5	§	30 - 50	Zero
445	Power	2.2 - 2.5	225 - 270	30 - 45	20 - 30
445	Power	2.2 - 2.5	225 - 270	30 - 45	20 - 30
480	Rectifier	4.2 - 5	360 - 440	48 - 58

* Remove oscillator tube.

† Tube generates own bias when oscillating.

|| Meter reading use 150 volt scale—true voltage 50-75—if lower scale voltmeter is used expect lower voltages.

§ Test from grid prong to ground approx. 125 volts.

‡ Test with plug in 2nd. Detector socket and tube in Analyzer.

MODEL 26-AW
Circuit #2 (Revised)
Schematic

SPARKS WITHINGTON CO.

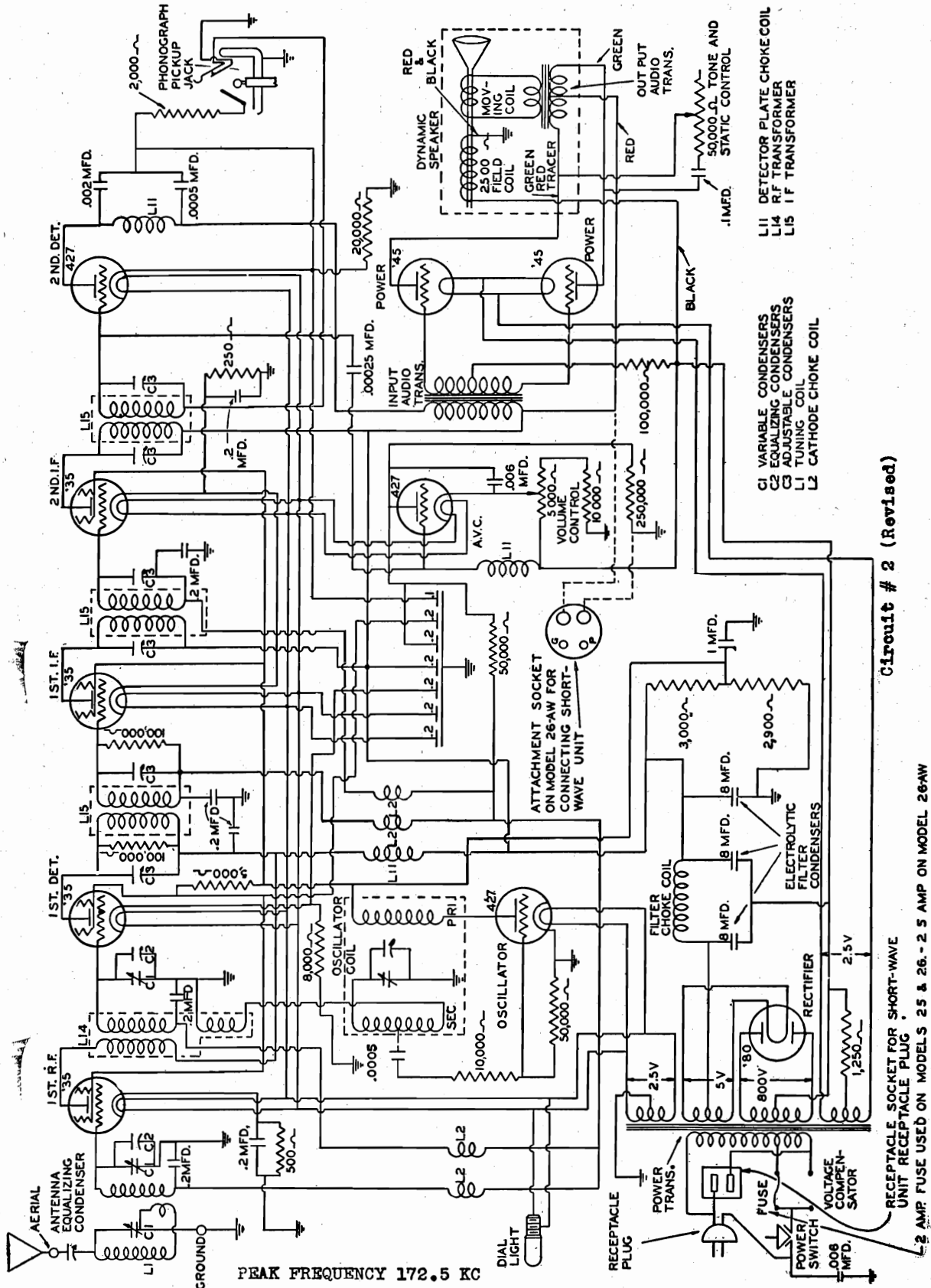

- L1 DETECTOR PLATE CHOKE COIL
- L4 R.F. TRANSFORMER
- L5 I.F. TRANSFORMER
- C1 VARIABLE CONDENSERS
- C2 EQUALIZING CONDENSERS
- C3 ADJUSTABLE CONDENSERS
- L1 TUNING COIL
- L2 CATHODE CHOKE COIL

Circuit # 2 (Revised)

RECEPTACLE SOCKET FOR SHORT-WAVE UNIT RECEPTACLE PLUG
L2 AMP. FUSE USED ON MODELS 25 & 26 - 2.5 AMP ON MODEL 26AW

PEAK FREQUENCY 172.5 KC

SPARKS WITHINGTON CO.

MODEL 30
Chassis
Voltage

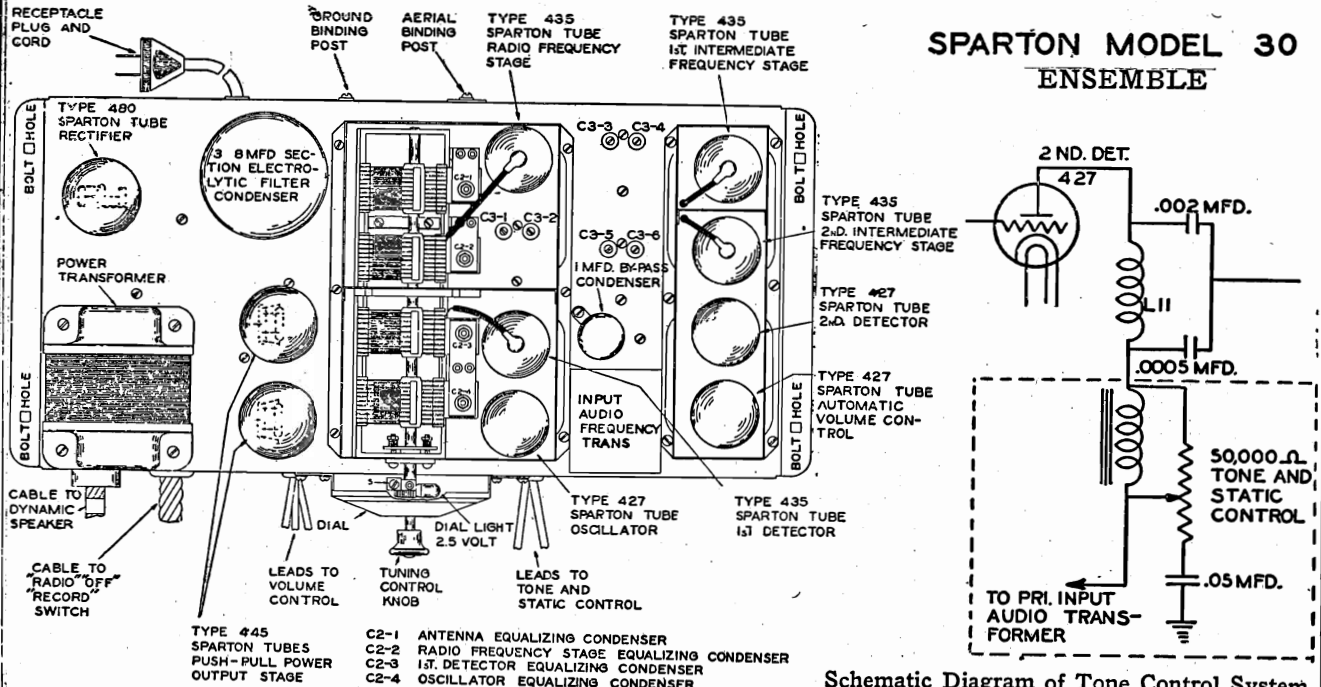

TOP VIEW

Schematic Diagram of Tone Control System used on a few of the first SPARTON Model 30.

Voltage-Current Characteristics

Line Voltage 115—Position of Voltage Compensator 100-115—Position of Volume Control Full

Tube	Location	OPERATING VOLTAGES					Plate Current Mills.
		Heater or Filament	Plate	Control Grid—	Screen Grid+		
435	1st R. F.	2.2 - 2.5	180 - 220	2.5 4	80 - 100	5 - 8	
435	1st Det.	2.2 - 2.5	180 - 220	*6.4 - 14	80 - 100	*.8 - 1.8	
435	1st I. F.	2.2 - 2.5	180 - 220	2.5 - 4	80 - 100	5 - 8	
435	2nd I. F.	2.2 - 2.5	180 - 220	2.5 - 4	80 - 100	5 - 8	
427	Oscillator	2.2 - 2.5	80 - 100	†	‡	
427	2nd Det	2.2 - 2.5	170 - 205	14 - 207 - 1.0	
427	A. V. C.	2.2 - 2.5	§	30 - 50	Zero	
445	Power	2.2 - 2.5	225 - 270	30 - 45	20 - 30	
445	Power	2.2 - 2.5	225 - 270	30 - 45	20 - 30	
480	Rectifier	4.2 - 5	360 - 440	48 - 58	

* Remove oscillator tube.

† Tube generates own bias when oscillating.

|| Meter reading use 150 volt scale—true voltage 50-75—If lower scale is used expect lower voltages.

§ Test from grid prong to ground approx. 125 volts.

‡ Test with plug in 2nd. Detector socket and tube in Analyzer.

MODEL 30
Service Data

SPARKS WITHINGTON CO.

Service Data for Sparton Ensemble Model 30
Automatic Phonograph Mechanism

The automatic phonograph mechanism of the Model 30 SPARTON Ensemble consists of three principal divisions: The Power Source, the Tripping mechanism, and the Discard-Indicating mechanism. A description of the construction and function of each division is outlined in the following paragraphs.

POWER SOURCE

The Power Source consists of (Fig. 1) Motor 1391 mounted between Top Plate C-623 and Bottom Plate C-619, which are held parallel by (Fig. 2) Spreader 1361 and together by (Fig. 1) eight screws 1363. A worm in the Motor Shaft meshes with the Worm Gear, on the Turntable Shaft and causes the Turntable Shaft to revolve. A portion of this shaft protrudes below the Worm Gear Chamber. On this portion of the shaft (Fig. 2) Pinion 1207 turns freely. It is held in position by Thrust Washers bearing on the end of (Fig. 1) Sleeve 1255, on which Clutch Spool 1206 is mounted and held by Pin 1351. This pin holds the Sleeve integral with the shaft, but allows the Clutch Spool to travel up and down. The pin works in the Slot on the Clutch Spool. The Clutch Spool always revolves with the Turntable Shaft. Raising the Clutch Spool causes one of its three teeth to mesh with one of the two teeth in (Fig. 2) Pinion 1207, causing Pinion to turn with the Turntable Shaft. The teeth of this pinion mesh with the teeth in the (Fig. 1) Compound Intermediate Gear A-6138 causing it to revolve, then the teeth in the Compound Intermediate Gear mesh with the teeth of (Fig. 2) Cam B-3715 and causes the cam to revolve in a clockwise direction. The Compound Intermediate Gear and Cam are held in position by Pivot Studs in the Top Plate, and (Fig. 2) Pivot Bearings, 1262 which are adjustable and locked into the Bottom Plate by means of Nut 733. These Pivot Bearings should be adjusted so the shafts turn freely, but do not move up and down. Cam B-3715 is the "heart" of the mechanism. All motions and power are derived from it, except the Power for (Fig. 3) Turntable C-617-A which is revolved by (Fig. 1) Rubber Washer 1321-1 acting against Metal Washer 1321-2 which is driven by a pin through

the top of the Turntable Shaft. The thrust from the Turntable Shaft is taken by (Fig. 1) Thrust Screw 1256-A, which is locked in position by Nut 773.

TRIPPING MECHANISM

When a record has been reproduced the needle in (Fig. 1) Pickup Unit A-6126 travels into the center of the record by means of the eccentric groove or the spiral groove depending upon the type of record. This motion is transmitted through Pickup Arm C-631, which is pivoted to (Fig. 3) Bracket 1269 by (Fig. 2) pivot screws 1270. (Fig. 3) Bracket 1269 is pivoted between the Top and Bottom Plates, at the top by (Fig. 2) Pivot Stud 1263 which is held in position by Top Support 1242-A and at the bottom by Pivot Bearing 1262. The motion of (Fig. 1) Pickup Unit A-6126 causes (Fig. 3) Bracket 1269 to move on a vertical axis. In case of Spiral Groove records (Fig. 2) Pawl Arm 1234 attached to Bracket 1269 moves in and out, causing Spiral Pawl 1245 to raise Trip Lever 1233. In case of Eccentric Groove records Eccentric Pawl 1246 raises Trip Lever 1233. This causes Throw-Out Lever 1275 to be released, allowing it to travel downward and act on (Fig. 1) Clutch Lever 1277-A which pivots on Stud 1467. This allows the forked end to travel upward, which causes Clutch Spool 1206 to also travel upward, and its lugs engage with the lugs on (Fig. 2) Driving Pinion Cam B-3715 through (Fig. 1) Compound Intermediate Gear A-6138. When the cam (Fig. 2) B-3715 has nearly completed its cycle the Lug on it passes under the cam surface of Throw-out Lever 1275, causing it to rise and be held in position by allowing the notch in Trip Lever 1233 to engage under the projection step in Throw-out Lever 1275. The Lug also prevents (Fig. 1) Clutch Lever 1277-A from rising. This holds Clutch Spool 1206 in mesh with (Fig. 2) Drive Pinion 1207 placing a strain on Spring 1266. When the Lug passes over the end of (Fig. 1) Clutch Lever 1277-A, the end snaps up, the forked end snaps down, and causes Clutch Spool 1206 to dis-engage from (Fig. 2) Pinion 1207. This stops the cycle operation.

MOVEMENT OF PICKUP

The (Fig. 1) Pickup Unit A-6126 is moved by means of (Fig. 3) Follow Arm 1271 attached to (Fig. 1) Pickup Unit A-621 by (Fig. 3) Screws 13830-7 and 13830-9. The Follow Arm is moved by a Pin on the end of it which travels in a groove on the top of (Fig. 2) Cam B-3715. One quarter of the way around the top of the Cam there are two grooves. When the Pin is in the inner groove, the needle in (Fig. 1) Pickup Unit A-6126 will lower at the starting position for 10" records. When the Pin is in the outer groove the Pickup Unit will lower at the starting position for 12" records. Cam Track Switch 1266 (not shown) changes this pin into groove required. This is done by (Fig. 3) Switch Cam 1297 being raised up by Shift Lever 1303-A, which is pulled forward by Pinion A-6136 in Soleoid A-6135-A which is energized by the Indicator Switch described in a subsequent discussion. When Switch Cam 1297 which is pivoted on Bracket 1307-A, is in contact with Finger 1308-A it causes the inner side of (Fig. 2) Cam B-3715 to rise, making it engage on lower lug of Cam Track Switch 1266 (not shown). This changes the position of the Cam Track Switch, causing the necessary movement for the Pickup Unit to lower to the starting position for 12" records.

DISCARD-INDICATING MECHANISM

(Fig. 3) Lift Lever 1302-A attached to Shift Lever 1303-A; is caused to rise at each revolution of the (Fig. 3) Cam B-3715 by a roller acting on a perpendicular surface inside of the cam. (Fig. 3) Shift Lever 1302-A is in the proper position to raise Cam 1297; it also will cause end of Lift Lever 1302-A to rise under the low part of (Fig. 2) Roller Arm 1471, causing Roller 1243 to rise on largest perpendicular cam surface on Cam B-3715. This causes (Fig. 1) Discarder B-3711-AA to be pulled back into the proper position to discard 12" records. (Fig. 3) Shift Lever 1302-A is not in the forward position, Lift Lever 1302-A does not come up under the low part of (Fig. 2) Roller Arm 1471 and the Roller travels around on the smaller perpendicular surface of Cam B-3715 and the (Fig. 1) Discarder B-3711-AA stays at the proper position to discard 10" records. These two discarder motions are accomplished by the fork in (Fig. 2) Roller

Arm 1471 engaging in the fork of (Fig. 1) Yoke 1238 which is attached to the top and bottom plate by (Fig. 2) Links 1217 and (Fig. 1) 1440 so the entire Discard Mechanism B-3711-AA can travel back and forth being controlled by (Fig. 3) Roller Arm 1471, which acts on either of the two perpendicular cam surfaces on Cam B-3715. To (Fig. 1) Link Yoke 1238, Links 1225 are attached. These Links are also attached to Discard Arm B-3711 and Shoe 1236. This gives a parallel motion to the Discard Arm up and down. This movement is accomplished by (Fig. 2) Lift Lever 1294 acting on (Fig. 1) Shoe 1226, when (Fig. 2) Lever 1284 is raised and lowered. Lever 1284 is raised and lowered by Lever 1279-A which is acted upon by the stud in it being in contact with the bottom surface of Cam B-3715. The inward motion of the Discarder is caused by the tension of Spring 1370 and is stopped by Stop Stud 1379. This relieves the pressure of Roller 1243 and allows Roller Arm 1471 to drop from the 12" record position to the 10" record position when the Roller is at the neutral part of cam surface. To prevent this roller from dropping down at any other time, (Fig. 1) Roller Arm Holdup 1452 is made up of, because (Fig. 2) Roller Arm 1471 is always over the vertical leg of (Fig. 1) Hold-up Arm 1453 when it is acting on the 12" cam surface. Repeat Lever 1377 is used when the continuous playing of one record is desired. This Lever when moved in, comes under Link 1225, making it impossible for Discard Arm B-3711 to Lower to the position to discard a record. (Fig. 3) Rest Hook 1349 is made use of when loading records. When Follow-Arm 1271 is placed on this hook, (Fig. 3) Discard Hold-up B-3713 is brought over (Fig. 2) Lever 1379-A, preventing it from acting to lower (Fig. 1) Discard Mechanism and remains in this position until it is pushed out by the Lug on (Fig. 2) Cam B-3715. This is why the Pick-up Unit can be brought to the center of the record and tripped without discarding the record, thus enabling the needle to start in the proper position, according to the record that is to be reproduced.

When (Fig. 1) pick-up Unit A-6126 causes mechanism to trip and begin a cycle of operation due to motion transmitted through it via the spiral or eccentric groove of the record, it is immediately swayed away from the center of the record and poled above the edge of the turntable. At the same instant the pick-up Unit has

SPARKS WITHINGTON CO.

MODEL 30
Service Data

SERVICE DATA FOR SPARTON ENSEMBLE, MODEL 30 PHONOGRAPH MECHANISM.

lower parallel arm of the indicator switch rides when the shaft turns as described.

When the roller of the indicator switch rides on a 10° record, the other roller attached to the other parallel arm, to which is also fastened another switch contact, does not rest on any surface and thus the switch remains unclosed.

When the switch sets on a 12° record both rollers rest on the record thus closing the switch. When this occurs, the closing of the switch energizes solenoid A-6135-A, which causes plunger A-6136 to be moved, which in turn actuates switch Cam 1297 attached to it.

The movement of switch Cam 1297 causes switch 1286 (not shown) to move the pin on the end of Follow Arm 1271 from the inner to the outer groove on (Fig. 2) Cam B-3715.

When this is done (Fig. 1) Pick-up Unit A-6126 lowers at the position to start a 12° record.

IF NEEDLE FAILS TO SLIDE FROM THE SMOOTH PART OF RECORD INTO THE ARM C-621 BEING TIGHT OR NOT PROPERLY ADJUSTED. (Fig. 3) Bracket 1269 should be tilted toward the discard compartment at top, which gives a natural tendency for the (Fig. 1) Pick-up Unit A-6126 to swing toward the center of record. This can be effected by loosening screws which hold (Fig. 2) Top Bearing Plate 1342-A and moving the Plate to the proper position. If Pick-up Arm is then out of center with the hole, it can be readjusted by Pivot Screws 1270.

ADJUST POSITION OF (FIG. 1) KICK-OFF ARM A-6117-A.

When the Kick-off Arm is in a stationary position the finger on the end should clear a 12° record by about 1/8", when the record is being raised from the turntable as shown in Fig. 1.

The position of the Kick-off Arm is regulated by (Fig. 2) finger A-7699 bearing against Cam A-6128. This finger is adjusted by the adjusting screws in adjusting block A-7697. The adjusting block is fastened to spindle A-6022 by set screw 1371.

HEIGHT OF (FIG. 1) GUIDE RAIL B-3709-A. The height is regulated by the position of nuts A-47-N.

BE SURE THAT ALL JOINTS OPERATE FREELY AND SMOOTHLY. A little oil in all joints and wearing surfaces will insure this condition.

BE SURE THAT ENSEMBLE IS STANDING REASONABLY LEVEL.

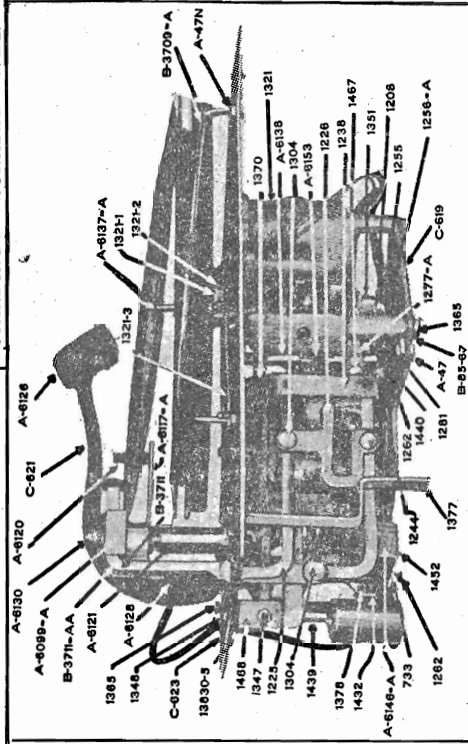

Fig. 1

stopped in its travel away from the center of the record the Finger on (Fig. 2) Cam 1280 attached to the top of Cam B-3715 engages with indicator finger A-7689 attached to indicator unit shaft A-6002.

Cam B-3715 revolves further, exerts additional influence on the indicator finger causing the (Fig. 3) indicator C-690 and kick-off arm A-6117 attached to it to describe a half circle. Kick-off Arm A-6117-A pushes record to be discarded into the receiving compartment.

When the Kick-off Arm A-6117-A has swung through its arc of travel outward, Indicator Switch B-3710-AA rests on the top record of the group on the turn table. This switch reaches this position only when the arm has completed its arc of travel, and is not visible when the arm has reversed its direction of movement.

This is due to a sloping edge cut on the (Fig. 1) indicator shaft bushing A-6121 onto which the

Adjustments on the Model 30 Automatic Phonograph Mechanism

CAUTION—Be sure that you understand exactly what the trouble is with the mechanism before starting to repair it. Do not attempt to "doctor" or "experiment". Remember, the mechanism operated perfectly at the factory.

TO ADJUST MECHANISM SO (FIG. 1) PICK-UP UNIT A-6126 COMES DOWN IN THE PROPER PLACE, adjust (Fig. 8) Screws 13880-7 and 13880-8 in and out as required. Keep the front surface of Follow-Arm 1271 parallel.

TO MAKE (FIG. 8) STOP SWITCH 1412-AA CUT OFF AT THE PROPER PLACE which occurs when (Fig. 1) Pick-up Unit A-6126 drops to its lowest position with no record on the Turntable, adjust screws which hold (Fig. 9) Stop Switch 1412-AA by loosening or tightening the front screw and the holdout screw where the Stop Switch fastens to the top plate.

TO ADJUST MECHANISM SO NEEDLE TRIPS ON INNER CIRCLE OF COLUMBIA RECORDS adjust (Fig. 2) Pawl Arm 1284 by means of screws which attach it to Bracket 1269 so that Pawl Spiral 1245 trips on vertical part of Trip Lever 1233. Spiral Pawl 1245 should clear serrated surface on Trip Lever 1234 by about 1/32".

TO ADJUST (FIG. 1) CLUTCH LEVER 1277-A, loosen Stud 1467 which is in a slot on Bracket 1244, until upper end of Clutch Lever clears the Lug on Cam B-3715 by about 1/32" when Clutch Spool is up as far as it will go. If Clutch rattles or fails to operate properly, it is

due to this adjustment. It is possible to change this adjustment by bending the lever, in cases where (Fig. 3) Stud 1467 is not in a slot.

TO ADJUST (FIG. 1) DISCARD ARM B-3711 FOR HEIGHT use set screw in (Fig. 2) Lever 1279-A. The discard arm should be adjusted so that 12° records just clear the top of (Fig. 1) Spindle A-6137-A when the Arm is in its highest upward position.

TO ADJUST (FIG. 3) DISCARD TONGUE A-6099-A, adjust screw A-1265-9. The proper distance for this adjustment is when Roller A-6082 rests on record, (Fig. 1) Discard Arm B-3711 is in the down position, and there is just room for the tongue to pass under a normal size record.

TO ADJUST (FIG. 1) DISCARD ARM B-3711 IN AND OUT adjust (Fig. 3) Discard Tongue A-6099-A so that it will just come down behind a record in its lowest position, using screws which hold Roller Bracket (Fig. 2) 1472-A to Roller Arm 1471.

IF MECHANISM TRIPS HARD, it is probably due to the fact that the notch in (Fig. 2) Trip Lever 1233 is not smooth or not machined at the correct angle. Also, it may be due to the fact that Spring 1366 has too much tension. Throw-out Lever 1275 should rise high enough when the Lug in Cam B-3715 is passing under it to allow the notch in Trip Lever 1233 to enter under the Lug on Lever 1275.

SPARKS WITHINGTON CO.

MODEL 30
Parts List

SPARTON ENSEMBLE MODEL 30

RECEIVING UNIT PARTS

Description	Part No.
Antenna Terminal and Insulation Assembly	A-6898
Body Complete—Amplifier	B-3627
Body Complete—Selector Assembly Top	B-3623
Bracket—Base Mounting	A-6718
Bracket—Dial Drive Support	B-4109
Bracket—2 Mfd. Condenser	A-7499
Bulb—Dial Light	A-5058
Chassis Less Tubes 25 Cycle	D-327
Chassis—Less Tubes 60 Cycle	D-326
Clamp—Cable 1/32" Radius	A-5215
Clamp—Cable 3/16" Radius	A-2251
Clip—Fuse	A-4983
Choke Coil—Cathode	A-7209
Choke Coil—Detector Plate	A-7297
Choke Coil—Filter	B-3429
Choke Coil—Tone Control	A-6862
Coil—Oscillator	A-6873
Coil—Tuning No. 1	A-6791
Coil—Tuning No. 2	A-6794
Condenser Frame and Anchor Plate Insulation	B-4021
Condenser—Double Equalizing	A-7054
Condenser—I. F. Adjustable and Bracket	A-7097
Condenser—Rotor Assembly	B-3648
Condenser—Single Equalizing	A-2053
Condenser Stator Assembly No. 1, 2, and 4	A-6582
Condenser Stator Assembly No. 3	A-6581
Condenser—.1 Mfd.	A-7475
Condenser—.2 Mfd. Cub	A-7005
Condenser—.2 Mfd. with Cap	A-4998
Condenser—.2 Mfd. Less Cap	A-7094
Condenser—.05 Mfd.	A-6927
Condenser—.002 Mfd.	A-7038-3
Condenser—.006 Mfd.	A-4434
Condenser—.0005 Mfd.	A-7038-1
Condenser—.00025 Mfd.	A-5175
Condenser—1 Mfd.	A-5032
Condenser—8 Mfd. Electrolytic	A-6884
Condenser—Block 7 Lead	B-4107
Contact—Rotor Shaft Center	A-5814
Contact—Rotor Shaft Front	A-5308
Contact—Rotor Shaft Rear	A-4317
Cotter Key—Drive Shaft	A-7130
Cover—Amplifier Body	B-3625
Cover—Bottom	B-4084
Cover—Electrolytic Condenser Assembly	A-6715
Cover—Selector Body	B-3621
Cushion—Rubber Mounting	A-6967
Dial Control Assembly	A-7070
Drive Disc and Light Shield Assembly	A-7166
Fuse—1½ Ampere	A-4980-4

RECEIVING UNIT PARTS (Continued)

Description	Part No.
Grommet—Rubber	A-5183
Insulation—Filter Condenser	A-7264-A
Insulation—Phonograph Volume Control	A-6970
Insulation—1st I. F. Transformer Shield	A-7445
Kilocycle Scale and Support	B-4120
Lug—I. F. Transformer Soldering	A-3737
Lug—Rivet Soldering	A-1866
Lug—Screw Soldering	A-1865
Nut—Equalizing Condenser	A-2269
Plate—Condenser Bearing	A-4226
Plate—Clamping	A-3799-A
Plate and Double Terminal	A-7051
Plate—Filter Condenser Mounting	A-6705
Plate—6 Point Resistor and Condenser	A-7055
Plate—Rotor Shaft Thrust	A-4310-A
Plate—Stator Clamping	A-5751
Pointer—Dial	A-7113
Receptacle Cord and Plug	A-6743
Resistor and Condenser Assembly	B-4259
Resistor—200 Ohm	B-4114-11
Resistor—250 Ohm	B-4114-3
Resistor—1250 Ohm	A-7018
Resistor—500 Ohm	B-4114-1
Resistor—2,000 Ohm	B-4114-6
Resistor—5,000 Ohm	B-4114-20
Resistor—8,000 Ohm	B-4114-2
Resistor—10,000 Ohm .5 Watt	B-4114-7
Resistor—10,000 Ohm 3 Watt	B-4114-5
Resistor—20,000 Ohm	B-4114-14
Resistor—50,000 Ohm	B-4114-12
Resistor—100,000 Ohm	B-4114-10
Resistor—2,900-3,000 Ohm	A-6619
Resistor—250,000 Ohm	B-4114-4
Screw—Aerial and Ground Binding Post	A-6575
Screw—Equalizing Condenser	A-3525
Screw—I. F. Adjustable Condenser	A-7692
Selector Assembly	C-687
Shaft—Drive and Spring	A-7165
Shaft—Drive and Washer	A-7058
Shield—Input Transformer	A-7680
Shield—Condenser Rear Stator	A-6767
Shield—Coil Copper Selector Assembly	B-3602
Shield—I. F. Adjustable Condensers	A-7211
Shield—I. F. Transformer Bottom	A-6600
Spacer Bushing—6 x 1%	A-6731
Spacer Bushing—¼ x 7/32	A-7040
Spacer Bushing—¼ x 5%	A-3725
Spring—Drive	A-7112

NO. 30-C

MODEL 30
Chassis Views

SPARKS WITHINGTON CO.

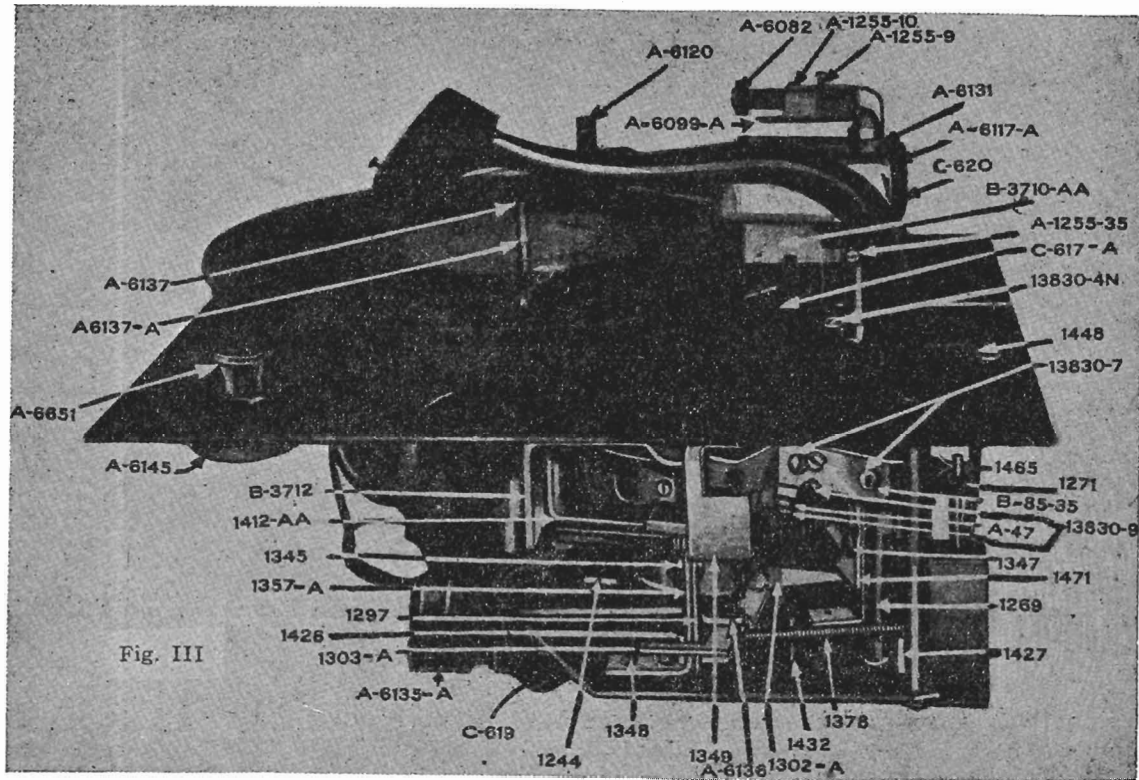
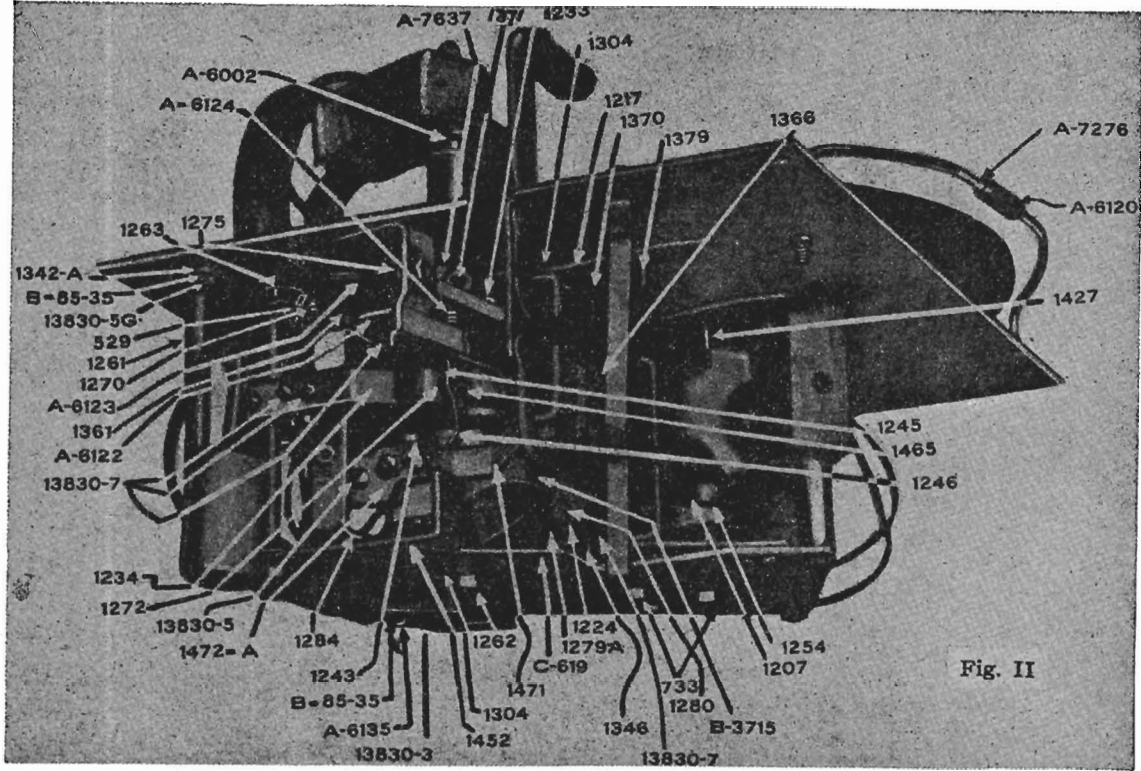

SPARKS WITHINGTON CO.

MODEL 31,32
Chassis Views

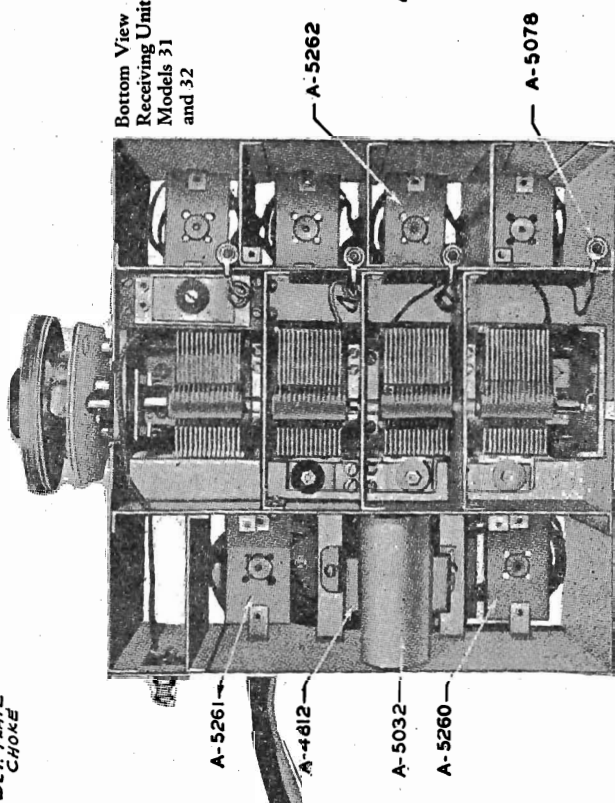
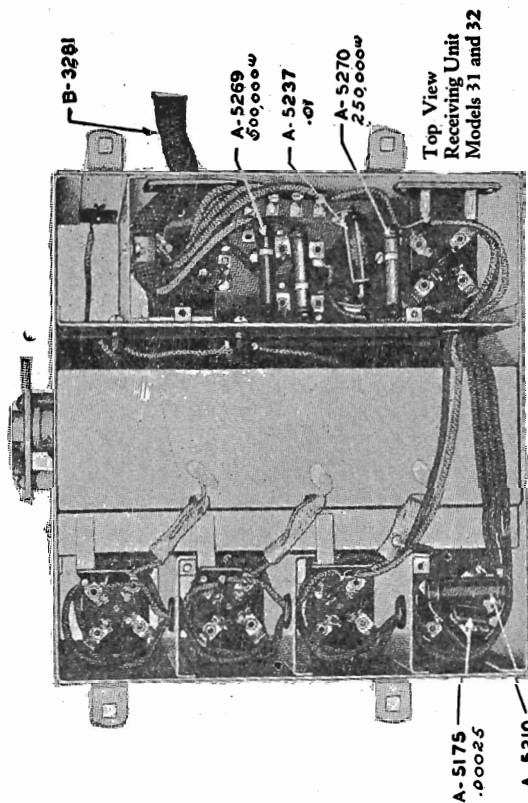
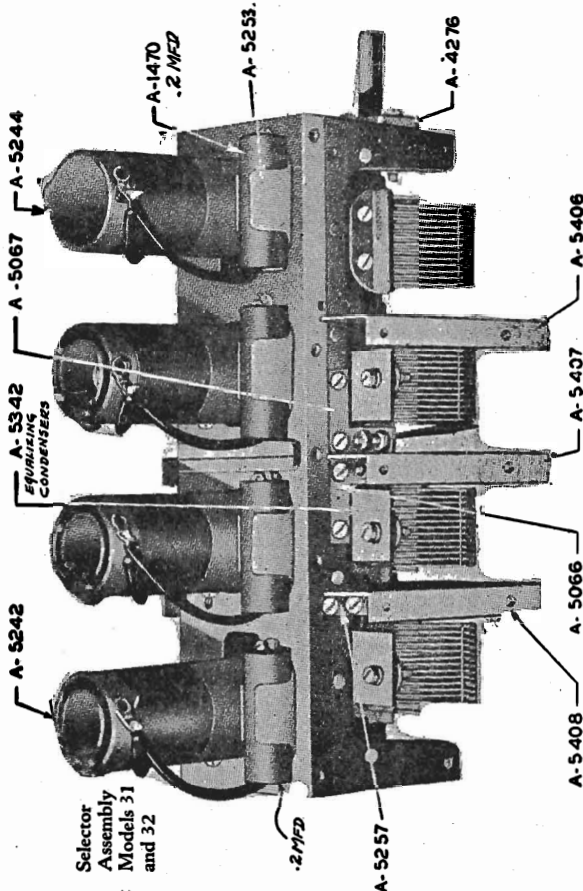
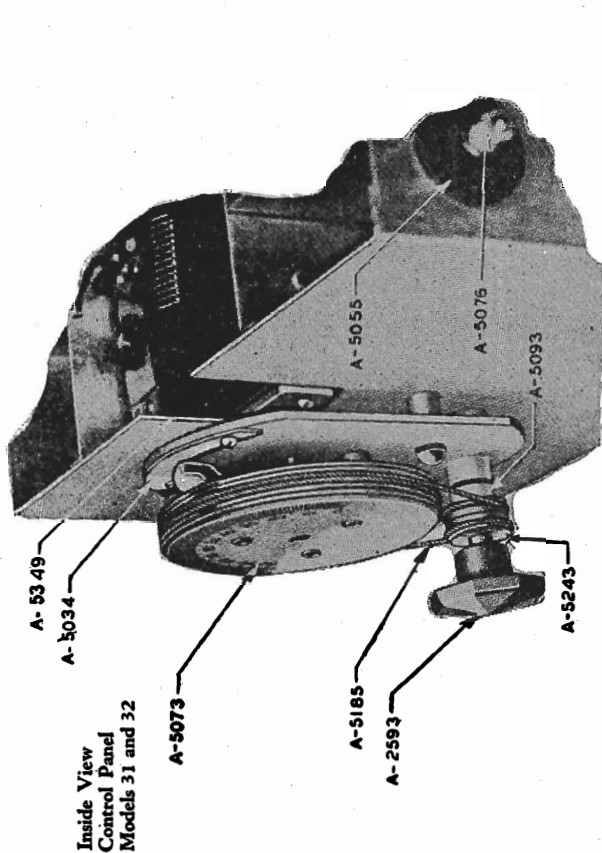

MODEL 35
Service Data

SPARKS WITHINGTON CO.

Service Data for Sparton Ensemble Model 35 Automatic Phonograph Mechanism

GENERAL OPERATION

At the completion of the reproduction portion of a record, the needle moves into the groove in the center of the record. The first oscillatory movement of the needle on an eccentric groove record, or the feed-in movement on a spiral groove record trips Trip Lever 814, *figure 1*.

Dog 813 *figure 2* for eccentric groove records and Spiral Trip Dog 833 for spiral groove records is attached to Pick-up Arm Lever 811 by means of Adjusting Stud 860 and Adjustment for Pick-up Lever 812. Pick-up Arm Lever 811 is attached to Pick-up Unit 904 *figure 3* by means of Yoke 867 and Pick-up Arm 866 which is connected to Bracket 810 *figure 4*, onto which Pick-up Arm Lever 811 *figure 2* is attached by means of two screws 155 *figure 4*. This whole device is allowed to swing from right to left due to its attachment to Standard 788 by the Dog Point Set Screws 823 which fit into the Bearing in Bracket 810.

When Trip Lever 814 *figure 1* is tripped, it allows Throwout Lever 822 to drop, and this causes Clutch Lever 816-C to push Clutch 525 into the Pins of Clutch Collar 527-C which is revolving; acting through Worm Gear 514-C which is driven by the Worm in Drive Shaft 793 connected to Motor by means of Drive Spring 877. The connecting of this Clutch causes worm shaft 524-C which is meshed with Cam Worm Gear 528 to cause Cam 789 to revolve and lower the Turntable to the "swing back" elevation. This is accomplished by Lift Lever 817 *figure 2* which is operated by Cam 789 *figure 1* acting on the bottom of Turntable Shaft 507-C, through Turntable Lift 516 *figure 2* and Adjustment 818 to which the Turntable Shaft is attached.

Turntable 510-C *figure 1* is driven in a clockwise motion by means of Worm Gear 553-C (not shown), which is meshed with Drive Shaft 793. This Worm Gear is provided with inside lugs which fit into the grooves in Turntable Shaft

507-C* and allows the Shaft to raise up and down without interfering with its turning motion

DISCARD POSITION OF TURNTABLE

Returning to the action of Cam 789 *figure 1* as it rotates further, Turntable 510-C* drops to the discard position, allowing the record to come in contact with Discard Rubber 650 *figure 4*. This raises the record above Receiving Stud 508 *figure 3* and the rotation of Turntable 510-C* then causes the record to be discarded into the Receiving Compartment.

"SWING BACK" OF PICKUP UNIT

Before the Cam 789 *figure 1* allows the Turntable to be moved into the discard elevation, and while the Turntable is still in the "swing back" elevation, the Pick-up Unit is swung away from the record by means of Index Lever 815 *figure 2* which is connected to the Pick-up Arm through Pick-up Arm Lever 811. The inner end of the slot in Index Lever 815 acts on Pin 763 *figure 1* that revolves with the Cam in a clockwise motion. It is through this means that the Pick-up is swung away from the record.

SLIDE MOVEMENT FOR 10" RECORDS

When Cam 789 *figure 1* starts to revolve, Eject Arm 790 *figure 2* also starts to revolve as it is driven by Dog 522. Roller 552 attached to Eject Arm 790, travels in the slot in Drive Lever 550 and causes it to move from the left to right, which moves Eject Slide 835-C and brings the center of the record over Receiving Pin 508 *figure 3* in Turntable 510-C*. This motion is caused by Drive Lever 550 *figure 2* acting through Link 852 attached to Lever 865 which is pinned to Shaft 558 connected to Top Lever 853-C which acts on Transverse Lever 854-C through Link 856. The Transverse Lever is connected to the twelve inch record Regulating Lever 859 which is fastened to Eject Slide 835-C by means of the Stud in the "L" shaped slot. This Stud remains in the "L" end of Lever

859 and allows Slide 835-C to place a ten inch record in the proper position over Receiving Stud 508 *figure 3*

SLIDE MOVEMENT FOR 12" RECORDS

In case a twelve inch record is on the Slide, Centering Lever 850-C *figure 4* is pushed out by the record to a position where its tail end trips the twelve inch Regulating Lever 859 *figure 2*. Eject Slide 835-C moves forward, causing the Stud to leave the "L" end of the slot in Lever 859 allowing Eject Slide 835-C to travel just far enough to place a twelve inch record over Receiving Stud 508 *figure 3*.

Ten or twelve inch records can be used without discrimination. The engagement of the needle on ten or twelve inch records is controlled by Engaging Regulator Weight 872 *figure 4* acting on Cable 900 which is attached to Index Lever 815 *figure 2*. When the Weight is allowed to act, Index Lever 815 is pulled over and the long slot engages on Pin 763 *figure 1* causing the Pick-up Unit to swing into the proper place to engage on a 12" record. If Regulator Weight 872 *figure 4* is not allowed to act, Index Lever 815 *figure 2* is carried over by means of Drag Link 580 *figure 1* so that the short notch engages on Pin 763 and the needle engages at the proper place to start a 10" record. Whether or not the Weight 872 *figure 4* is allowed to act depends on Shaft 824 which, when under Weight 872, keeps the Weight from acting. Shaft 824 is controlled by Engaging Regulator Arm 787.

When a 12" record is fed out, Centering Lever 850-C *figure 4* is pushed out. The Finger on it carries Arm 787 out with it, swinging end of Shaft 824 from under Weight 872, allowing 872 to act. Shaft 824 will remain in this position until a 10" record is fed out of the Hopper. Thus, a 12" record may be repeated on the Turntable as many times as desired. When a 10" record is fed out of the Hopper, Eject Slide 835-C *figure 2* goes out farther over the Turntable, allowing Pin 887 to come in contact with Arm 787 causing it to move so that Shaft 824

takes a position under Weight 872 and prevents it from acting. This position will be held until a 12" record is fed out of the Hopper, thus, a 10" Record will continue to repeat until the position of Shaft 824 is changed.

RECEIVING POSITION OF TURNTABLE

Again returning to the motion of Cam 789 *figure 1* further rotation of this Cam causes the Turntable to rise to receiving elevation in time to receive the record which has been moved to the positions just described. The Turntable remains in this position while the Cam rotates further, allowing Roller 552 *figure 2* which is attached to Eject Arm 790, to travel in the slot in Drive Lever 550 and return Eject Slide 835-C to its original position. As soon as Eject Slide 835-C has returned to this position, Cam 789 *figure 1* has revolved to a position where it allows the Turntable to drop to the "swing in" elevation.

"SWING-IN" MOVEMENT OF PICK-UP UNIT

At this time Pin 763 *figure 1* has revolved far enough to connect with either the ten or twelve inch notch in Index Lever 815 *figure 2*. Its further revolution causes the Pick-up to swing in over the record so the Needle rests on the smooth part of the record as the Turntable is raised to reproducing elevation by means of Cam 789 *figure 1*. Regulating Weight Lever 872 *figure 4* on Standard 788 now causes the Pick-up to move over from the smooth part of the record to the first reproducing groove. Reproduction of the record begins at once.

COCKING MECHANISM AND STOPPING CYCLE OF CAM

When the Pick-up Unit first swings away from the record, Pick-up Arm Lever 811 *figure 2* passes under the tail of Throwout Lever 822 *figure 1*, causing it to rise to a position where the notch in Trip Lever 814 is allowed to enter its proper place under the lug in Throw-out Lever 822, holding Throwout Lever 822 in this

Parts Lists Numbers: *524, *1026, *B-3700, *A-6000

SPARKS WITHINGTON CO.

MODEL 35
Service Data

(Continued)

position after the Pick-up Arm Lever 811 *figure 2* no longer supports it. When the Throwout Lever is raised to this position, a spring tension is created which pulls on Clutch Lever 816-C *figure 1* attempting to pull back and open Clutch 526 but Clutch Lever 816-C is held in the engaging position by means of Control Disc 864-C until the Cam has completed its entire revolution when a notch in the Control Disc allows the Clutch Lever to follow the urge of the spring and disengage the Clutch.

REPEATING

In case it is desired to play the same record over, the repeat Button *figure 5* is moved to the left. This moves Repeat Lever 809 *figure 2* causing it to press against Drive Dog 522 causing the Dog to recede and not catch on Eject Drive Arm 790. Eject Drive Arm 790 remains stationary and the Eject Slide does not move. The Cam revolves and the Turntable goes through all of the elevating positions except the discard elevation. Eject Arm 790 does not allow Roller 845 to drop to the discard elevation in Cam 789 *figure 1*, thus the record will be repeated until the Repeat Lever is moved to the right.

CONTROL OF RECORDS

When Eject Slide 835-C *figure 4* comes forward, the bottom record is caught between the "v" shaped plates 836 and 837 *figure 3* which brings the bottom record forward with the Slide. The other records slide over the top of these "v" shaped plates and remain in the Hopper. Only the bottom record is allowed to come out of the Hopper onto the Turntable. Other records are prevented from coming out by means of the two Admitters 819-C which are devised so they gauge themselves according to the thickness of the record. Thick, thin or warped records are fed out through the action of the admitters without injury to the records or mechanism. The admitters are held down against the record by means of springs and are adjusted by Screws 902. Back Stops 871 prevent records from sliding too far back in Hopper.

If a ten inch record is on the bottom and is not in the center, it is forced into the center by the two Centering Levers 850-C *figure 4* and 848-C *figure 3* which are held in position under tension by Springs 569 *figure 4* and 566 *figure 3*. These Springs are right and left hand and are attached to bushings in Studs, which have right and left hand threads and have a tendency to keep the spring from unscrewing the studs and nuts which hold them.

These Springs hold the Centering Lever against the Stop Pins which are set so that they hold the Centering Levers just the right distance to allow a 10" record to pass through with a slight amount of tension. In case a 12" record is on the bottom, these Springs are allowed to open up and the Centering Lever 850-C *figure 4* acts to trip the mechanism as described under the paragraph about Slide Movement for 12" records.

THE STARTING BUTTON

In starting or rejecting records, the Starting Button *figure 5* is pressed. When this Button is pressed slightly, it causes the contacts in switch 897-A *figure 2* to be spread apart which changes the fields in the motor from a series connection to a parallel connection for a greater starting torque. Pressing down further causes Lever 662 *figure 2* to act against Throwout Lever Trip 814 and trip mechanism which discards the record. This is the same action as though it were tripped with the Dogs 813 or 814.

THE CLUTCH SWITCH

Clutch Switch 896-A on Bracket 876 *figure 1* is operated by Clutch Lever 816-C by means of a fibre switch Opener, the purpose of this switch is to allow switch 898-A *figure 4* to be opened when the Clutch is engaged and the Cam is in motion. This carries the current whenever Clutch is in motion and the Pick-up Unit is not resting on a Record.

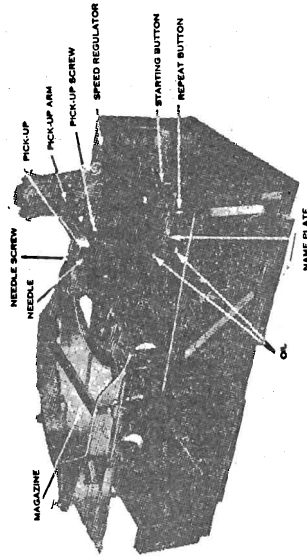

FIGURE 5

THE PICK-UP UNIT SWITCH

Pick-up Switch 898-A *figure 4* is attached to the back of Standard 788. When the Pick-up is not resting on a record, the Pick-up Arm drops down, swiveling at Trunnion Pin 641, *figure 3*. This allows the Brake Shoes on Pick-up Arm 866 to rise and press against Cork Insert 623 *figure 4* which is in the Brake Adjustment 685. This retards the Swinging action of the Pick-up and allows it to move only when forced by Index Lever 816 *figure 2*. This Brake Adjustment 685 can be regulated to bring the Pick-up to the height desired and is locked in place by a nut.

Through the center of Brake Adjustment 685 is a Fibre Rod 590 *figure 4* which also rests on Brake Shoe 974 and is raised whenever the Brake is closed. The upper end of this acts on the Contact Spring in Switch 898-A and causes it to open the Switch and break the entire circuit, acting the same as the Clutch Switch in parallel with it. With both of these switches open, the power supply is entirely cut off. Also, when this switch is open a contact is formed with the upper part of the Switch which cuts out Speed Regulating Rheostat No. 544 *figure 2* and allows the full power to be used while the Cam is in the operating cycle.

Lubrication on the Sparton Ensemble Model 35 Automatic Phonograph Mechanism

The Model 35 automatic phonograph mechanism is thoroughly lubricated at the factory when assembled and requires no oiling or greasing except as noted in this section.

THE ELECTRIC MOTOR ARMATURE SHAFT BEARINGS. Oil once every six months. Use nothing but light fine oil. Located on the

upper side of the motor board *figure 5* are two (2) pipe plugs marked "OIL." Remove these plugs and inject a quantity of oil in the tubes under them. This lubricates both armature shaft bearings. The wick type oil wells used on the bearings keep the bearings well lubricated for a six (6) months period of normal operation.

MODEL 35
Adjustments

SPARKS WITHINGTON CO.

consistency of vaseline, mixed with graphite if possible. In the main body casting, housing the turntable shaft and worm gears two (2) pipe (2) pipe plugs 687 *figure 4* marked "Grease." Remove these Plugs and inject a small quantity of grease in the openings.

KNUCKLES, JOINTS AND BEARINGS. Oil once every six (6) months. Use nothing but light fine oil.
AUTOMATIC MECHANISM GEARS AND BEARINGS. Grease once every year. Use nothing but a good grade of grease of about the

Adjustments on the Sparton Ensemble Model 35 Automatic Phonograph Mechanism

ADMITTERS 819-C FIGURE 3. Use Adjusting Screw 902. Turning this screw in a clockwise direction raises the end of the admitter higher. The height of the admitter should be just enough to touch a record on the Eject Slide 835-C *figure 2* when the slide is out.

ALIGNMENT OF MOTOR DRIVE SPRING 877, FIGURE 1 WITH DRIVE SHAFT 793. Two adjustments are provided for this purpose, one for aligning the spring if it is horizontally off center with the drive shaft and the other for alignment if the spring is vertically off center.

To align the spring if horizontally off center loosen the four collars (see 574-C, *figure 1*) on Screw Studs 797. This will then allow either side of Motor 895-C to be moved back or forth on the studs as the case demands. To align the spring if off center vertically, the Hex. nut on Stud 799 should be loosened or tightened depending upon whether the motor is to be tipped up or down.

PICKUP UNIT TO STRIKE AT PROPER PLACE ON RECORD. Use adjusting Screw 535 *figure 2*. The needle in the Pickup Unit should strike about 1/8 inch in from the outside edge of the record.

PICKUP UNIT TO TRIP MECHANISM ON SPIRAL GROOVE RECORD. Use adjusting Screw 812, *figure 2*. The mechanism should trip

Eject Slide should carry out a 10 inch Victor record to a distance where the tip of Receiving Stud 508, *figure 3*, enters the hole in the record at the front side of the hole. If a 10" Columbia record is used to make this adjustment, the stud should enter the hole in the record at the rear side.

END PLAY IN CAM WORM SHAFT 524-C, FIGURE 1. Use Adjusting Screw 525-C. The end play in this shaft should be just enough to be detected when shaft is moved back and forth by hand. If end play is too great, the clutch will remain engaged and the mechanism will not automatically stop when the last record has been reproduced.

PICKUP SWITCH 398-A, FIGURE 4. This switch is adjusted by loosening the two screws turntable shaft and worm gears are located two by which it is fastened to standard 788, and moving it up or down so the contacts will close when the pickup unit is on a record in reproducing position.

CLUTCH SWITCH 896-A, FIGURE 1. This switch is adjusted by loosening the two screws

which hold Bracket 876 to the body casting and moving the bracket one way or the other so the contacts will close when clutch 626 is in gear. Clutch 526 is placed in gear immediately after a record has been discarded automatically or manually.

END PLAY IN DRIVE SHAFT 793, FIGURE 1. Use Adjusting Screw 706-C, *figure 4*. The end play in this shaft should be just enough to be detected when shaft is moved back and forth by hand. If end play is too great, the reproduction of a record will have a wavering effect.

SPRING TENSION ON CENTERING LEVER 848-C and 850-C, FIGURE 4 and 3, RESPECTIVELY. Use Adjusting Screws 847 and 849, *figure 4*. The spring tension on these levers must be equal and sufficient to hold the center of a record in a line with Receiving Stud 508, *figure 3*. If the tension is insufficient or unequal, Eject Slide 835-C, *figure 2*, will not center the record over turn-table 510-C. Loosen these screws and turn them to the right or left to increase or decrease tension as the case demands.

(Continued)

Resistor Data

SPARKS WITHINGTON CO.

STANDARD RESISTOR COLOR CODE AND RESISTORS USED IN SPARTON RADIO RECEIVING SETS AND SPARTON ENSEMBLES

Standard Resistor Color Code

- 0—Black
- 1—Brown
- 2—Red
- 3—Orange
- 4—Yellow
- 5—Green
- 6—Blue
- 7—Violet
- 8—Gray
- 9—White

To determine the value of a resistor, the first significant figure of resistance value is represented by the color of the body of the resistor, and the second

figure of resistance value by the color of the tip of the resistor. The number of ciphers following the second figure is determined by the color of the dot or stripe in the center of the body of the resistor. For example, a 20,000 ohm resistor has a red body, black tip, with orange dot or orange stripe. A 2,200 ohm resistor would be red body, with red tip and red dot, or red stripe, and as all colors are the same, it would be a single color resistor.

CARBON RESISTORS

Part No.	Ohms	Watts	Body	Tip	Dot Stripe
B-4114-11	200	.5	Red	Black	Brown
B-4114-3	250	.5	Red	Green	Brown
B-4114-1	500	.5	Green	Black	Brown
B-4114-13	1,000	.5	Brown	Black	Red
A-3397	1,000	2	Light Brown		
A-3397	1,000	2	Brown	Black	Red
A-3750	1,250	3	Brown	Orange	Red
A-3750	1,250	3	Black	Silver	Orange
A-3750	1,250	3	Black		
A-3750	1,250	3	Slate		
A-3325	1,700	2	Dark Brown		
A-3639	1,700	5	Gray	Silver	
A-4613	1,700	1	Brown	Violet	Red
A-5550	2,000	.5	Red	Black	Red
B-4114-6	Use A-5550				
A-5622	2,500	3	Red	Green	Red
A-3232	2,800	.5	Black	Paper Label	
A-4122	2,800	.5	Gray		
A-4122	2,800	.5	Red		
A-4653	2,800	.5	Red	Gray	Red
A-5180	5,000	.5	Green	Black	Red
B-4114-16	Use A-5180				
B-4114-20	Use A-5180				
B-4114-25	7,000	.5	Violet	Black	Red
B-4114-2	8,000	.5	Gray	Black	Red
A-3764-C	10,000	4	Blue		
A-3735	10,000	5	Brown	Black	Orange
A-3735	10,000	5	Gray	Silver	Blue
A-4614	10,000	1	Brown	Black	Orange
B-4114-7	10,000	.5	Brown	Black	Orange
B-4114-5	10,000	.3	Brown	Black	Orange
A-4107	15,000	5	Brown	Green	Orange
A-4107	15,000	5	Gray	Silver	
B-4114-23	15,000	.5	Yellow	Black	Orange
A-2934	20,000	2	Green		
A-2934	20,000	2	Red	Black	Orange
A-3422	20,000	3	Gray		Green
A-3422	20,000	3	Red	Black	Orange
A-4261	20,000	5	Red	Black	Orange
A-4261	20,000	5	Gray	Silver	Blue
B-4114-14	20,000	.5	Red	Black	Orange
B-4114-24	Use B-4114-14				
A-7111	25,000	4.5	Red	Green	Orange

Effective January 1, 1932

SPARKS WITHINGTON CO.

Resistor Data

CARBON RESISTORS—Continued

Part No.	Ohms	Watts	Body	Tip	Dot Stripe
B-4114-18	25,000	.5	Red	Green	Orange
A-5139	30,000	1	Orange	Black	Orange
B-4114-19	30,000	.5	Orange	Black	Orange
B-4114-22	40,000	.5	Yellow	Black	Orange
A-3423	50,000	3	Gray		Red
A-3423	50,000	3	Green	Black	Orange
B-4114-12	50,000	.5	Green	Black	Orange
B-4114-15	60,000	.5	Blue	Black	Orange
A-5354	100,000	1	Brown	Black	Yellow
B-4114-10	100,000	.5	Brown	Black	Yellow
B-4114-8	150,000	.5	Brown	Green	Yellow
A-2702-5	200,000		Glass		
B-4114-17	200,000	.5	Red	Black	Yellow
A-1514	250,000		Glass		
A-4234	250,000	1	Red	Green	Yellow
A-5270	Use A-4234				
B-4114-4	250,000	.5	Red	Green	Yellow
A-2702-6	Use A-1514				
A-5269	500,000	1	Green	Black	Yellow
B-4114-9	500,000	.5	Green	Black	Yellow
A-5138	1,000,000	1	Brown	Black	Green
B-4114-21	1,000,000	.5	Brown	Black	Green
A-2702-11	1,000,000		Glass		
A-1515	3,000,000		Glass		
A-2702-13	Use A-1515		Glass		

WIRE WOUND RESISTORS

Part No.	Ohms	Watts	Color	Type	Part No.	Ohms	Watts	Color	Type
A-7411	.43			Special	A-7118	250	1	Blue	Wire Wound
A-6890	.54	2.5	5-23/32"	Wire	A-5137	330	1	Gray	Wire Wound
A-6889	.67	2.5	7-7/64"	Wire	A-3536	900	10	Black	Wire Wound
A-5863	2	5	Blue	Wire Wound	A-7119	1,050	7.5	Blue	Wire Wound
A-4363	7	20	Blue	Wire Wound	A-7018	1,250	4		Candohm
A-7509	8-9			Wire Wound	A-4974	1,250	5	Gray	Candohm
A-5140	(.11 ohms per ft. at 20° C.)			Wire	A-6617	1,500	2	Brown	Braided
A-5862	12	10	Blue	Wire Wound	A-3383	3,000	10	Black	Wire Wound
A-4364	12	30	Blue	Wire Wound	A-3535	7,000	10	Black	Wire Wound
A-5890	14	10	Blue	Wire Wound	A-4583	Use A-3535			
A-4366	15	50	Blue	Wire Wound	A-2043	10,000	6	Black	Wire Wound
A-7421	35	.25	Red	Braided	A-4356	20,000		Blue	Wire Wound
A-5889	54	175	Blue	Wire Wound	A-3811	30,000	.5	Black	Wire Wound
A-5861	57	175	Blue	Wire Wound	A-3642	(6.04 ohms per ft. at 20° C.)			Wire Wd. Tap.
A-4365	63	10	Blue	Wire Wound	A-4260	2,000-7,000	20	Black	Wire Wd. Tap.
A-3590	110	1	Black	Wire Wound	A-5426	1,800-2,400	8	Blue	Wire Wd. Tap.
A-4670	110	1	Black	Wire Wound	A-5870	Use A-5426			
A-4915	110	1	Black	Candohm	A-6619	2,900-3,000	15	Blue	Wire Wd. Tap.
A-7427	160	1	Blue	Wire Wound	A-7120	2,400-3,200	4.5	Blue	Wire Wd. Tap.
A-6618	200	.5	Red	Braided	A-7461	3,900-4,300		Blue	Wire Wd. Tap.
A-5502	200	1	Red	Candohm	A-6977	5,500-6,000	7	Blue	Wire Wd. Tap.
A-6976	230	3	Blue	Wire Wound	A-7462	60-220-2,100		Blue	Wire Wd. Tap.

NO. 13-C

MODEL 40
Schematic
Voltage

SPARKS WITHINGTON CO.

SPARTON MODEL 40 SCHEMATIC DIAGRAM
(AUTOMOBILE RECEIVER)

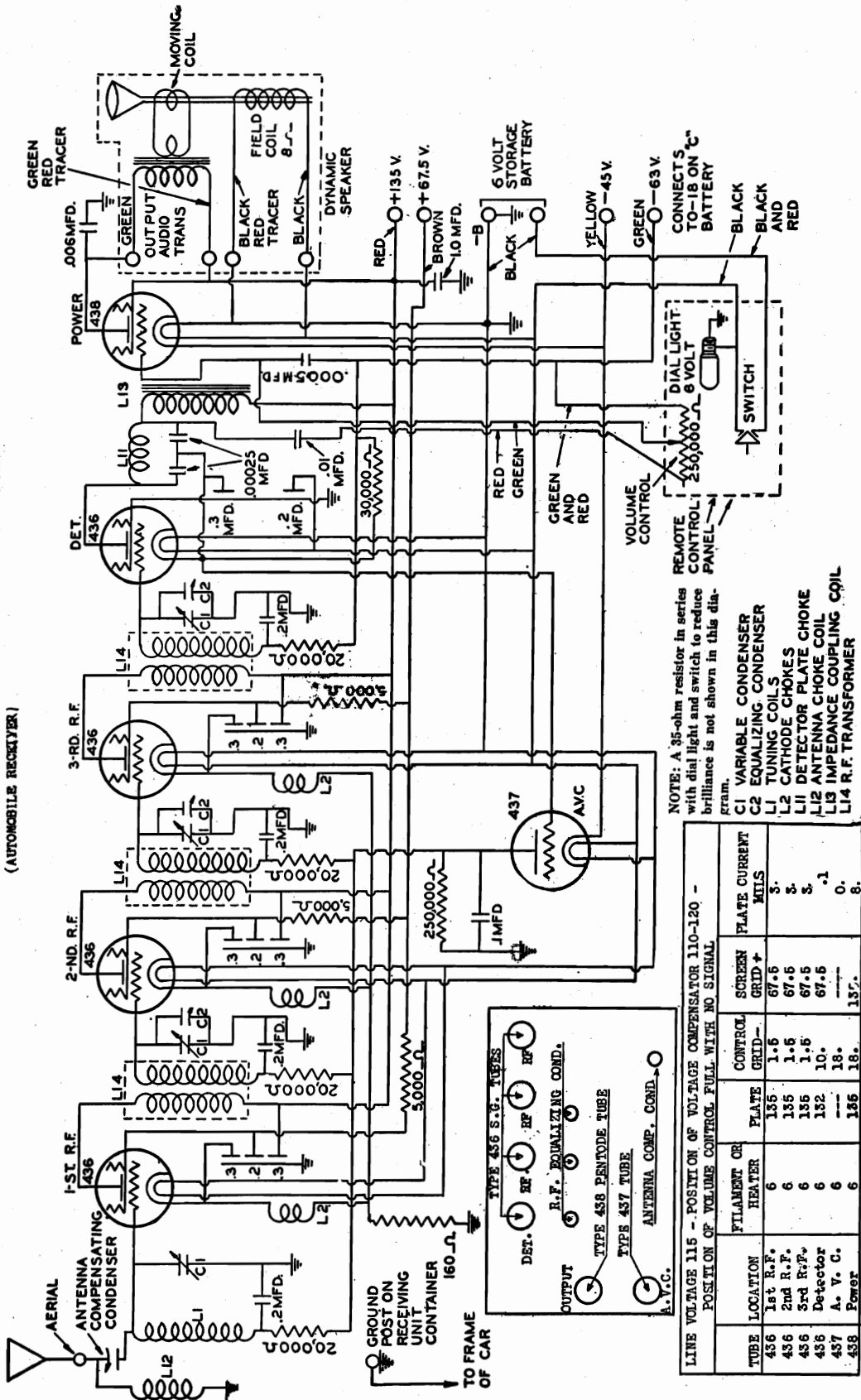

LINE VOLTAGE 115 - POSITION OF VOLTAGE COMPENSATOR 110-120 -
 POSITION OF VOLUME CONTROL FULL WITH NO SIGNAL

TUBE	LOCATION	FILAMENT OR HEATER	PLATE	CONTROL GRID-	SCREEN GRID +	PLATE CURRENT MILS.
436	1st R.F.	6	135	1.5	67.5	3.
436	2nd R.F.	6	135	1.5	67.5	3.
436	3rd R.F.	6	135	1.5	67.5	3.
436	Detector	6	152	10.	67.5	.1
437	A. V. C.	6	---	18.	---	0.
438	Power	6	135	18.	137.	8.

SPARKS WITHINGTON CO.

MODEL 41
Schematic
Voltage

POLICE AUTO RECEIVER

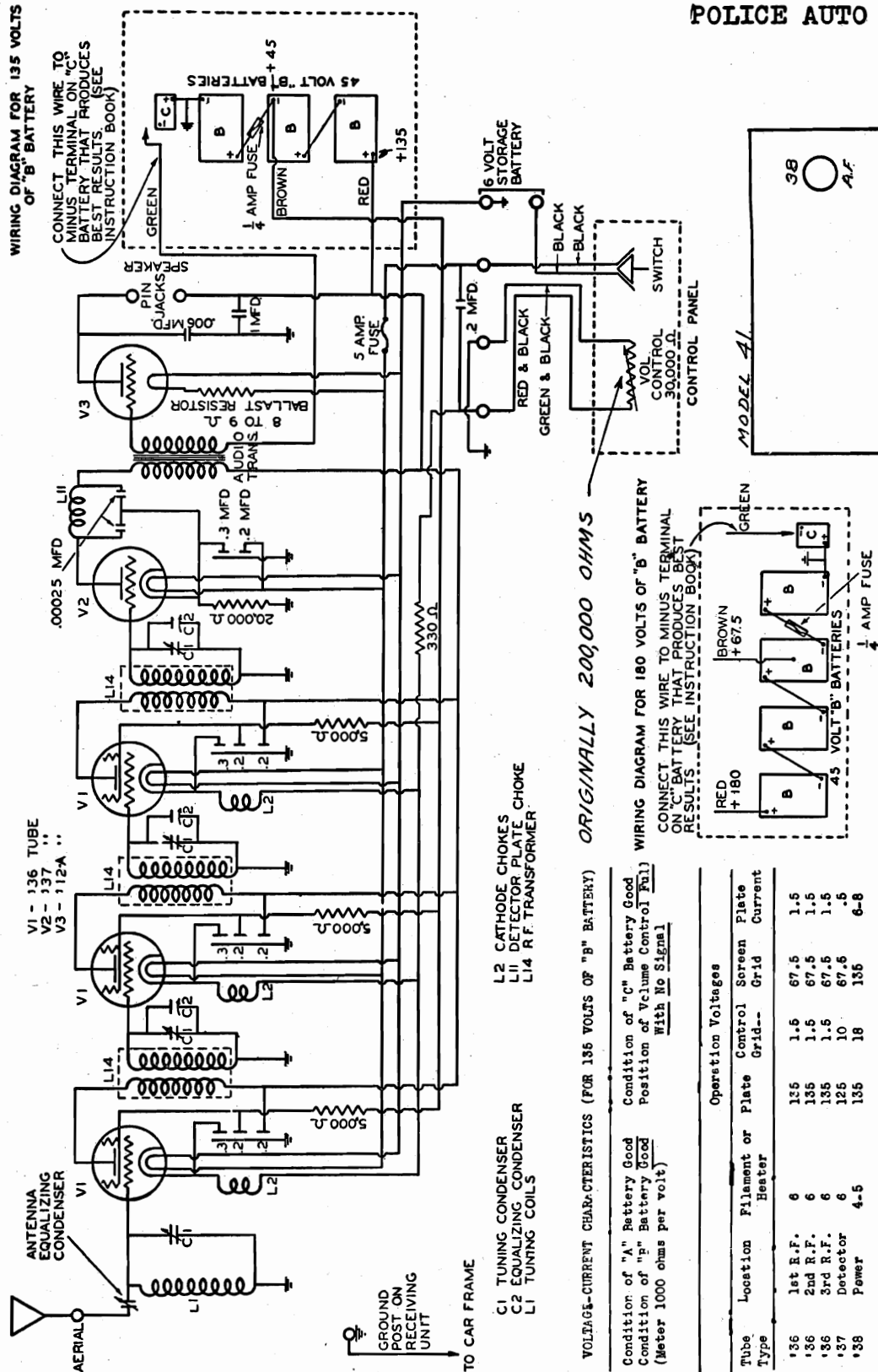

WIRING DIAGRAM FOR 135 VOLTS OF "B" BATTERY

CONNECT THIS WIRE TO MINUS TERMINAL ON "C" BATTERY THAT PRODUCES BEST RESULTS. (SEE INSTRUCTION BOOK)

ORIGINALLY 200,000 OHMS

WIRING DIAGRAM FOR 180 VOLTS OF "B" BATTERY
CONNECT THIS WIRE TO MINUS TERMINAL ON "C" BATTERY THAT PRODUCES BEST RESULTS. (SEE INSTRUCTION BOOK)

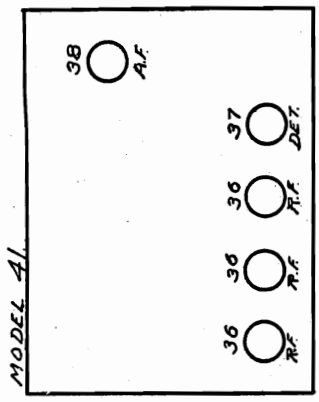

MODEL 41

- L2 CATHODE CHOKES
- L11 DETECTOR PLATE CHOKE
- L14 R.F. TRANSFORMER

- C1 TUNING CONDENSER
- C2 EQUALIZING CONDENSER
- L1 TUNING COILS

VOLTAGE-CURRENT CHARACTERISTICS (FOR 135 VOLTS OF "B" BATTERY)

Condition of "A" Battery Good
Condition of "B" Battery Good
(Meter 1000 ohms per volt)

Condition of "C" Battery Good
Position of Volume Control (Full)
With No Signal

Tube Type	Operation Voltages			
	Location	Filament or Heater	Control Grid--	Screen Grid Plate Current
*36	1st R.F.	6	1.5	67.5
*36	2nd R.F.	6	1.5	67.5
*36	3rd R.F.	6	1.5	67.5
*37	Detector	6	10	67.5
*38	Power	4-5	18	135

SPARKS WITHINGTON CO.

MODEL 45
Chassis
Voltage

Line Voltage 115—Position of Voltage Compensator 100-115—Position of Volume Control Full

Tube	Location	OPERATING VOLTAGES				Plate Current Mills.
		Heater or Filament	Plate	Control Grid—	Screen Grid+	
435	1st R. F.	2.2 - 2.5	180 - 220	2.5 - 4	80 - 100	5 - 8
435	1st Det.	2.2 - 2.5	180 - 220	*6.4 - 14	80 - 100	*.8 - 1.8
435	1st I. F.	2.2 - 2.5	180 - 220	2.5 - 4	80 - 100	5 - 8
435	2nd I. F.	2.2 - 2.5	180 - 220	2.5 - 4	80 - 100	5 - 8
427	Oscillator	2.2 - 2.5	80 - 100	†	‡
427	2nd Det.	2.2 - 2.5	170 - 205	14 - 207 - 1.0
427	A. V. C.	2.2 - 2.5	§	30 - 50	Zero
445	Power	2.2 - 2.5	225 - 270	30 - 45	20 - 30
445	Power	2.2 - 2.5	225 - 270	30 - 45	20 - 30
480	Rectifier	4.2 - 5	360 - 440	48 - 58

(Measured with 1000 ohm per volt voltmeter)

* Remove oscillator tube.

† Tube generates own bias when oscillating.

|| Meter reading use 150 volt scale—true voltage 50-75—if lower scale voltmeter is used expect lower voltages.

§ Test from grid prong to ground approx. 125 volts.

‡ Test with plug in 2nd. Detector socket and tube in Analyzer.

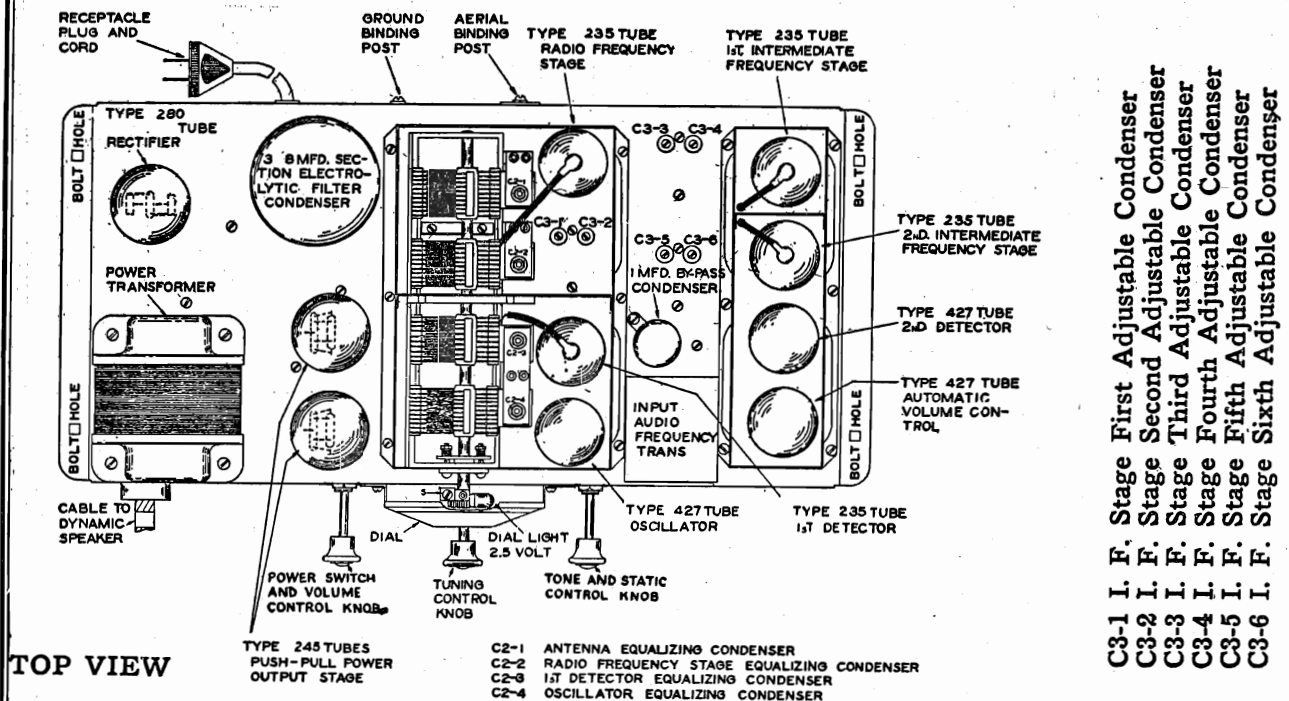

MODEL 51,52
Schematic
Voltage

SPARKS WITHINGTON CO.

Sparton Model 51 and 52 Schematic Diagram

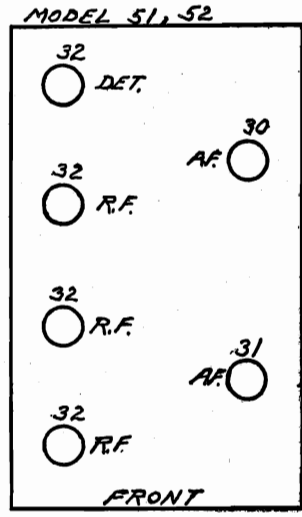
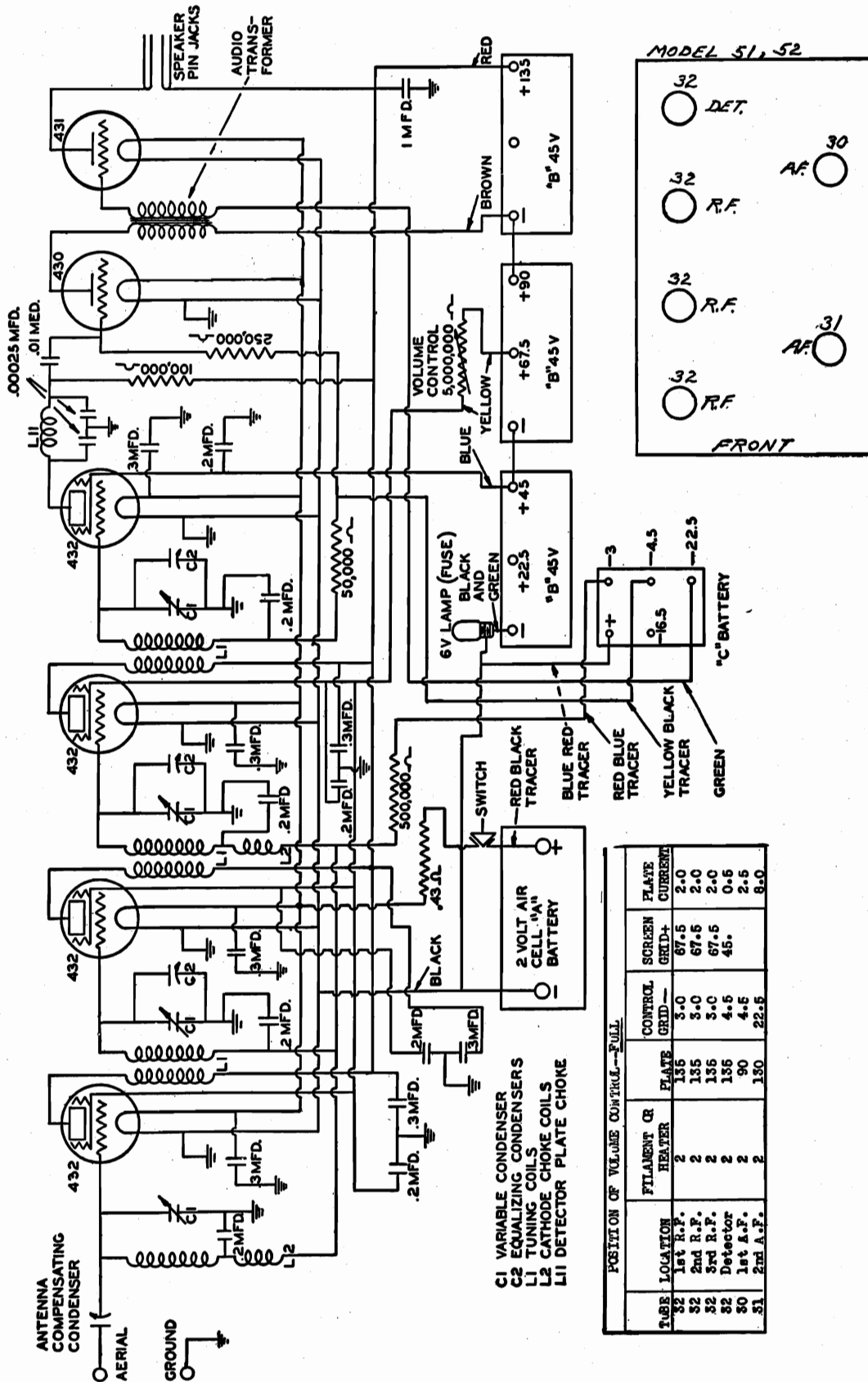

- C1 VARIABLE CONDENSER
- C2 EQUALIZING CONDENSERS
- L1 TUNING COILS
- L2 CATHODE CHOKE COILS
- L11 DETECTOR PLATE CHOKE

POSITION OF VOLUME CONTROL—FULL

TUBE	LOCATION	FILAMENT OR HEATER	PLATE	CONTROL GRID—	SCREEN GRID+	PLATE CURRENT
32	1st R.F.	2	135	3-0	67.5	2-0
32	2nd R.F.	2	135	3-0	67.5	2-0
32	3rd R.F.	2	135	3-0	67.5	2-0
32	Detector	2	135	4-5	45.	0-5
30	1st A.F.	2	90	4-5		2-5
31	2nd A.F.	2	180	22-5		8-0

SPARKS WITHINGTON CO.

MODEL 51,52
Tone Control
Speaker Cone
Data

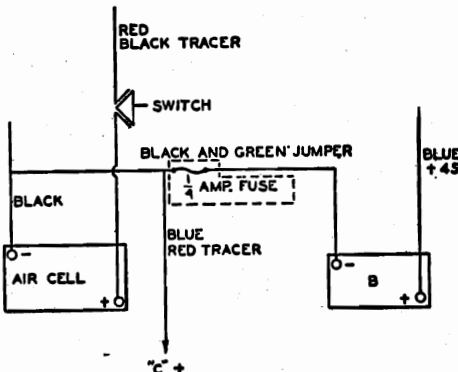
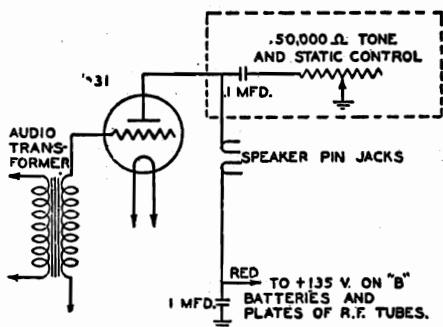

SCHMATIC
DRAWING OF TONE
AND STATIC
CONTROL AND
1/4 AMPERE "B"
BATTERY FUSE
USED ON MODLES
51 AND 52
SERIAL NOS. 345
AND 195 UP
RESPECTIVELY

WIRING DIAGRAM FOR 180
VOLTS OF "B" BATTERY
SPARTON MODEL 51 AND 52

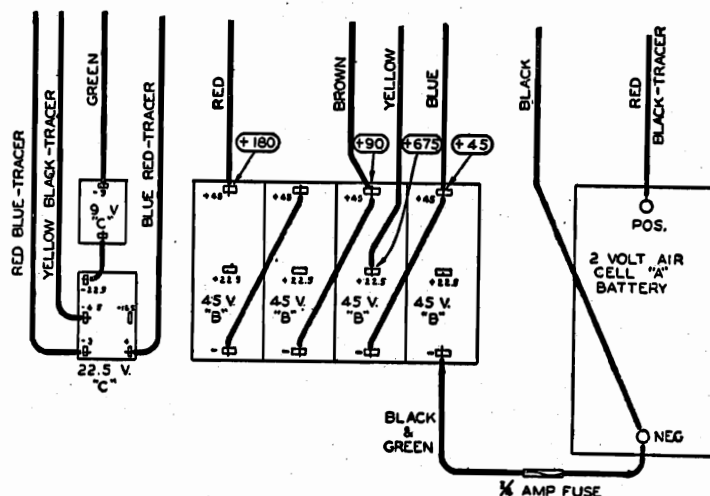

How to Replace Cone Head in Magnetic Speaker in Model 51 and 52

First:

Remove the motor or speaker driving element by removing the four mounting screws, unsoldering the lead wires from the outside terminal lugs, and unsoldering the driving link from the diaphragm apex pin.

Second:

Remove the cone head and all paper rings from the speaker housing.

Third:

Coat the rim of the speaker housing where the paper ring on the diaphragm rests with an ample coating of cellulose cement (such as Du Pont's Household Cement or Ambroid).

Fourth:

Place the cone head (part No. B-3528) into position, set the speaker housing onto a flat surface with the opening of diaphragm down, place a weight on housing and leave until cement is dry.

Fifth:

Fasten the driving motor back into position with four mounting screws, making sure that the movable armature of the motor is in exact center between the pole pieces before mounting, and solder the lead wires to the terminal lugs.

Sixth:

Solder the diaphragm apex pin to the apex driving link, making sure not to exert any strain on the drive link which might put the motor armature out of center while soldering. The apex pin should be cut off before soldering, so that it will extend about 1/4" along the drive link. Use ordinary soft solder.

Seventh:

Next cement the paper ring (part No. A-5847) and finally the paper ring (part No. A-5846) into position, using cellulose cement.

**MODEL 56
Voltage
Socket
Trimmers**

SPARKS WITHINGTON CO.

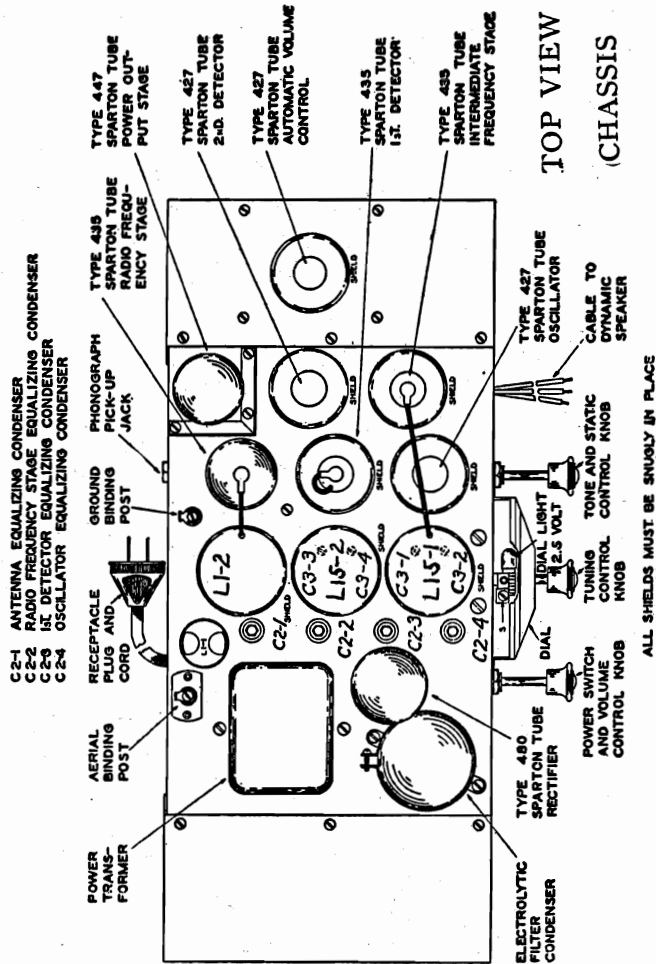

- L1-1 First R. F. Tuning Coil
- L1-2 Second R. F. Tuning Coil
- L15-1 First I. F. Transformer (1st. Det. to I.F. Stage)
- L15-2 Second I. F. Transformer (I.F. to 2nd. Det. Stage)
- C3-1 I. F. Stage First Adjustable Condenser
- C3-2 I. F. Stage Second Adjustable Condenser
- C3-3 I. F. Stage Third Adjustable Condenser
- C3-4 I. F. Stage Fourth Adjustable Condenser

Voltage Current Characteristics

Line Voltage 115—Position of Voltage Compensator 100-115—Position of Volume Control Full

Tube	Location	OPERATING VOLTAGES				Plate Current Mills.
		Heater or Filament	Plate	Control Grid -	Screen Grid +	
435	1st R. F.	2.2 - 2.5	230 - 270	2.5 - 4.0	85 - 100	5 - 8
435	1st Det.	2.2 - 2.5	230 - 270	**4.5 - 7.5	85 - 100	**1.8 - 3.5
435	1st I. F.	2.2 - 2.5	230 - 270	2.5 - 4.0	85 - 100	5 - 8
427	Oscillator	2.2 - 2.5	85 - 110	†	‡
427	2nd Det.	2.2 - 2.5	*100 - 135	8 - 14	4.0 - .7
447	Power	2.2 - 2.5	220 - 260	15 - 18	230 - 270	30 - 36
480	Rectifier	4.2 - 5	360 - 420	40 - 55

*Use 300 volt scale. †Tube generates own bias when oscillating.
 **Remove Oscillator tube. ‡Test with plug in 2nd. Detector socket and tube in analyzer

SPARKS WITHINGTON CO.

MODEL 60
Short Wave
Converter

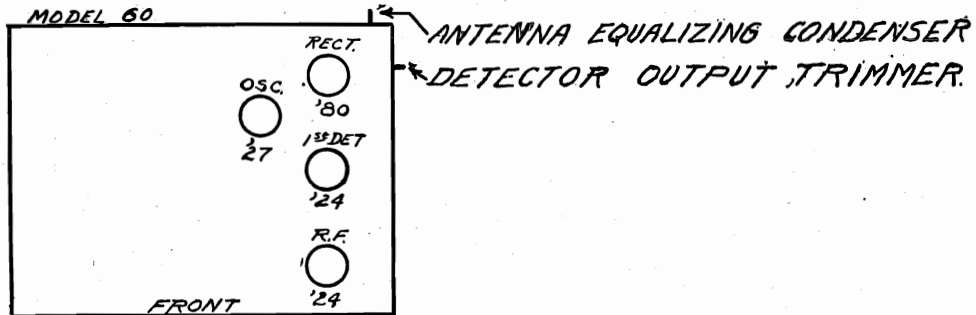

MODEL 60 SHORT-WAVE CONVERTER

Tube	Location	Filament Heater or	Plate	Control Grid -	Screen Grid +	Plate Current M. A.
'24-A	R. F.	2.2 - 2.5	180 - 230	2 - 3	70 - 100	3 - 6
'24-A	Detector	2.2 - 2.5	180 - 230	*5 - 6	70 - 100	.2 - 1
427	Oscillator	2.2 - 2.5	180 - 230	†	-----	§
'80	Rectifier	4.4 - 5.0	230 - 260	-----	-----	7 - 10

LINE VOLTAGE 115

POSITION OF VOLUME CONTROL FULL

† Tube generates own bias when oscillating.

* Presence of voltage can only be determined by testing circuit continuity and measuring the plate and screen grid current of this tube. Voltage is five thousand times current in amperes.

§ Measure with plug in the second detector socket and tube in test kit.

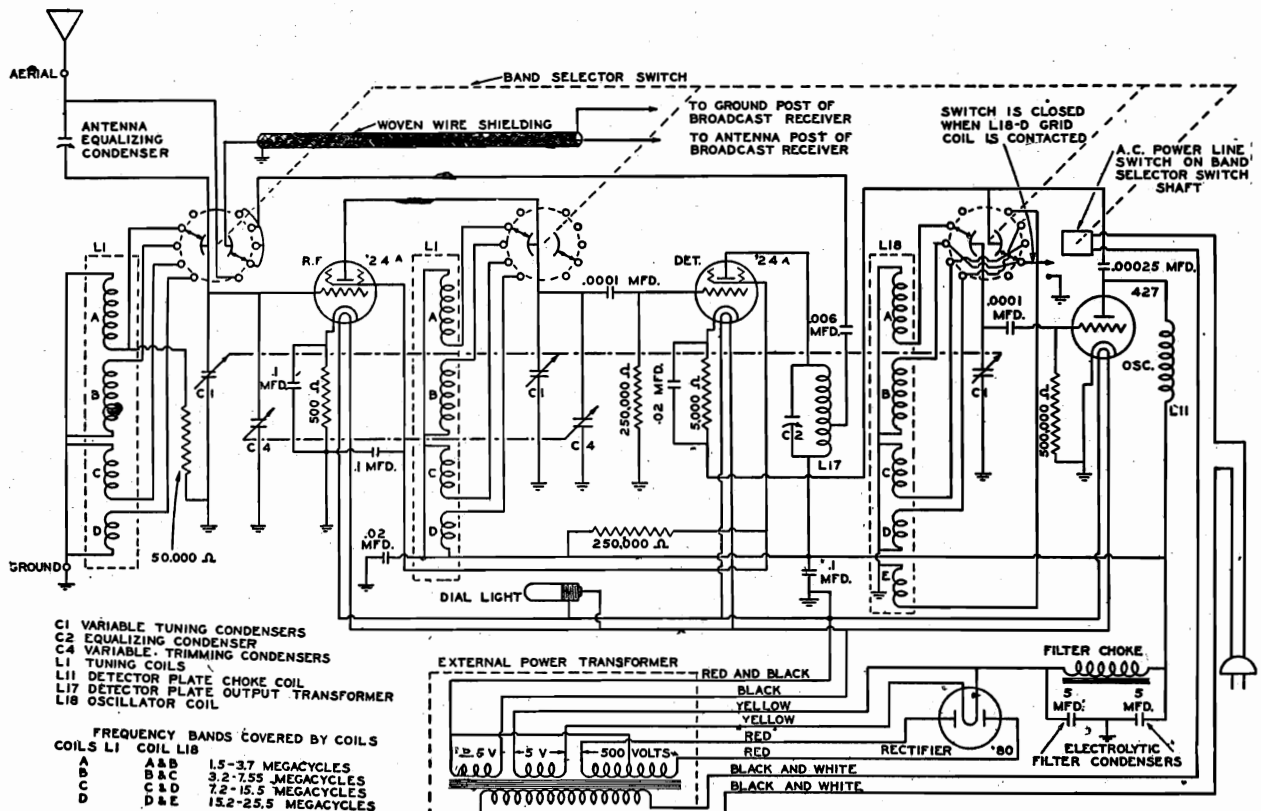

MODEL 103,578.
 Assembly Wiring
 Voltage

SPARKS WITHINGTON CO.

SPARTON ENSEMBLE MODEL 103
 AND 578 WIRING ASSEMBLY

SPARTON—Model 103.
 Line Voltage 120—Volume Control Full

TUBE NO. OR SOCKET	TYPE	POSITION OF TUBE	TUBE OUT		TUBE IN TESTER		CATHODE	NORMAL	PLATE	SCREEN
			WOLFS	WOLFS	WOLFS	WOLFS				
1	6X4	1st. R.F.	3	125	3	125	8	415	773	310
2	6X4	2nd. R.F.	3	125	3	125	8	615	114	419
3	6X4	3rd. R.F.	3	125	3	125	8	915	115	415
4	6X4	4th. R.F.	3	125	3	125	8	615	11.2	417
5	6X4	5th. R.F.	3	120	3	120	8	613	11.0	417
6	6X4	Det.	3	240	3	185	32	318	6	212
7	585	Aud10	7.9	345	7.7	340	65	55	60	5
8	281	Rect.	8	—	—	—	—	55	60	5
9	281	Rect.	8	—	—	—	—	68	—	—
10	281	Rect.	8	—	—	—	—	68	—	—

Model 103—1 Additional 227 Tube, Also 1 Additional 484 in Selector

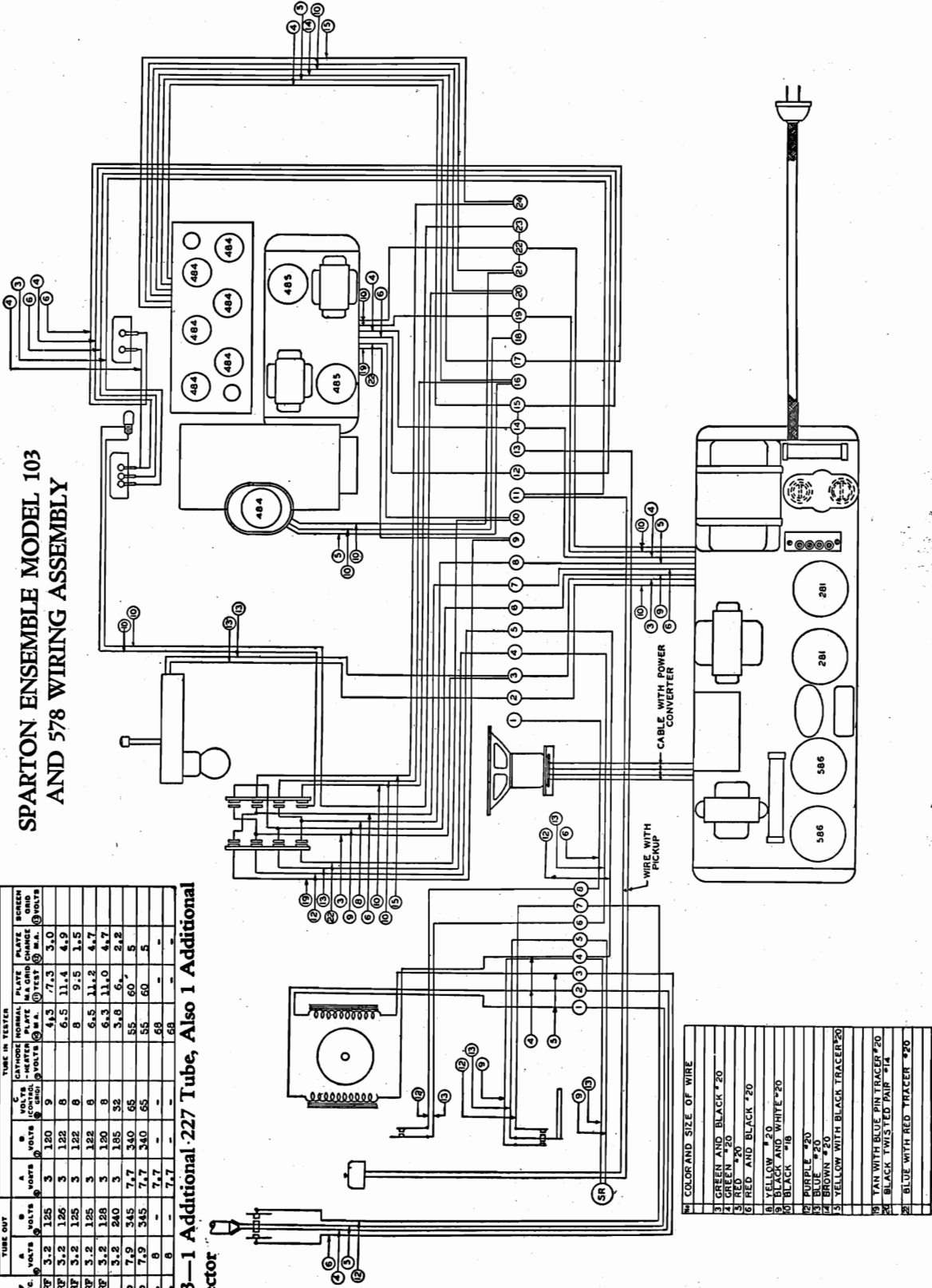

NO.	COLOR AND SIZE OF WIRE
1	GREEN AND BLACK #20
2	GREEN #20
3	GREEN #20
4	RED AND BLACK #20
5	YELLOW #20
6	BLACK #18
7	PURPLE #20
8	BROWN #20
9	YELLOW WITH BLACK TRACER #20
10	YAN WITH BLUE PIN TRACER #20
11	BLACK TWISTED PAIR #14
12	BLUE WITH RED TRACER #20

SPARKS, WITHINGTON CO.

MODEL 103,578
Schematic.

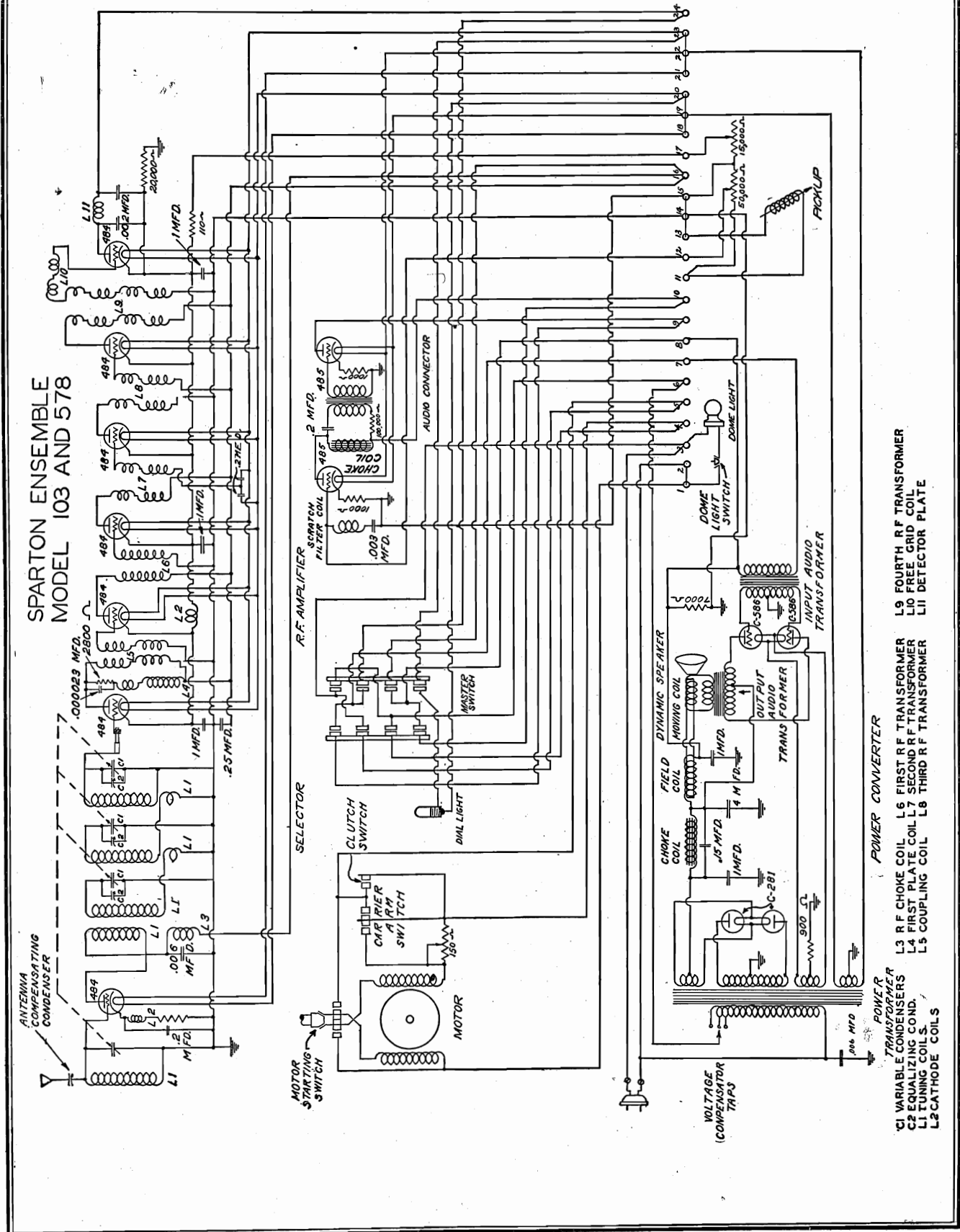

SPARTON ENSEMBLE
MODEL 103 AND 578

- C1 VARIABLE CONDENSERS
- C2 EQUALIZING COND.
- L1 TUNING COIL S.
- L2 CATHODE COIL S
- L3 R F CHOKE COIL
- L4 FIRST PLATE COIL
- L5 COUPLING COIL
- L6 FIRST R F TRANSFORMER
- L7 SECOND R F TRANSFORMER
- L8 THIRD R F TRANSFORMER
- L9 FOURTH R F TRANSFORMER
- L10 FREE GRID COIL
- L11 DETECTOR PLATE

**Antenna Trimmer
Service Notes**

SPARKS WITHINGTON CO.

No. 3 to a point where the station sounds the loudest.

5. Next adjust No. 1 and No. 2 in the same manner.

TO CHECK ADJUSTMENT

6. Tune in a station between 15 and 25 on the dial.

7. Readjust the Antenna Compensating and the Equalizing Condensers No. 3, No. 1, and No. 2 in exactly the same manner as they were adjusted between the 80 to 90 setting of the dial. The purpose of this adjustment is to check the "tracking" of the four condensers. The volume of the station should decrease if any of the four original adjustments are changed. That is, the four tuned circuits must show alignment between 15 and 25 on the dial on the adjustment made between 80 and 90.

TO READJUST

8. After the check between 15 and 25 on the dial, it will be necessary to again readjust the condensers as explained in No. 1 to No. 5 inclusive. This is necessary due to the adjustments being slightly thrown off during the checking process.

SPARTON MODELS 410 AND 420

Follow the same procedure outlined for adjusting the antenna compensating and equalizing condensers for the SPARTON Models AR-19 and 31, except in this case ear phones are not substituted for the speaker as a means of determining when the condensers are properly adjusted. The speaker serves this purpose as it is, and as the dial is calibrated in kilocycles a station is tuned in at 1200 kilocycles or higher frequency instead of between 80 and 90 as specified in paragraph No. 1, and the re-check is made between 500 and 600 kilocycles instead of between 15 and 25.

11. Next, tune in a station between 1100 and 1300 kilocycles and see if it reads correctly on the dial.

12. If stations tune in to maximum volume at a setting different from station's correct kilocycle reading, turn dial to the reading, the station should come in on according to its log-book reading. Then readjust the Condensers as explained in No. 1 to No. 5.

13. This final adjustment will scarcely affect the calibration of the stations around 600 kilocycles and will properly align the Selector Unit to its highest efficiency, and will cause the dial to read correctly over the entire broadcast spectrum.

MODELS AR-19 AND 31

Due to the construction of these Models, it is not convenient to connect a Voltmeter at the proper place in the circuit so it can be used as a resonance indicator, therefore, a pair of ear phones are substituted for the speaker and are used as the means of determining when the antenna compensating and equalizing condensers have been properly adjusted.

1. With aerial and ground wires connected to the set as they are to be permanently used, tune in a Distant Station between 80 and 90 or higher on the dial.

2. Turn Volume control down until station is barely audible.

3. Adjust Antenna Compensating Condenser with insulated handle screw driver to a point where the station sounds the loudest.

4. The Equalizing Condensers are numbered 1, 2, and 3, from front to back of receiver. Reduce the volume control until the station is barely audible and with the adjusting wrench, adjust

How to Adjust the Antenna Compensating and Equalizing Condensers

tune in a Distant Station at 1200 kilocycles or at a higher frequency.

2. Turn Volume Control on FULL for this entire adjustment.

3. Adjust Antenna Compensating Condenser screw with insulated handle Screw Driver until indicator reaches highest point on Voltmeter scale. NOTE: The numerical value that the indicator reaches is of no consequence. The object is to have the indicator deflect from zero upward as high as possible.

4. The equalizing condensers are numbered 1, 2, and 3. Number 3 is next to the dial drum. With the adjusting wrench, adjust No. 3 until the indicator reaches highest point on the Voltmeter scale.

5. Next adjust No. 1 and No. 2 in the same manner.

TO CHECK ADJUSTMENT

6. Tune in a station between 550 and 650 kilocycles.

7. Readjust the Antenna compensating condenser and the Equalizing condensers No. 3, No. 1, and No. 2 in exactly the same manner as they were adjusted at the 1200 or higher kilocycle setting of the dial. The purpose of this adjustment is to check the "tracking" of the four variable condensers. The voltmeter reading should decrease if any of the four original adjustments are changed. That is, the four tuned circuits must show alignment between 550 and 650 kilocycles on the ADJUSTMENT made at 1200 or higher kilocycle setting.

TO READJUST

8. After the check at 550 kilocycles it will be necessary to again readjust the condensers as explained in No. 1 to No. 5 inclusive. This is necessary, due to the adjustments being slightly thrown off in the checking process.

in place and slide the strip so the reading is correct for the station being received.

NOTE: (On Models 410, 420)—If station reads off its proper setting, loosen the screws which hold the dial drum to the condenser shaft and move the drum one way or the other, until the reading is correct for the station being received. When doing this be sure that the condenser shaft does not turn when the dial is moved.)

SPARTON MODELS 103, 235, 564, 570, 574, 578, 589, 591, 593, 600, 610, 620, 740, 750 AND 870, ALSO MODELS EQUIPPED WITH PHONOGRAPH PICKUP JACK MANUFACTURED PRIOR TO JUNE 1, 1936.

After the aerial and ground have been inspected and found to be in good order, and all tubes have been tested and placed in their proper sockets, the final operation in the installation of a SPARTON Radio Receiving Set is adjustment of the antenna compensating and equalizing condensers. This adjustment should ALWAYS be made with the use of a High Resistance Voltmeter as a resonance indicator. Using the ear as a resonance indicator should be resorted to only when it is impossible to employ a Voltmeter.

Any 1,000 ohm per volt 0-60, 75 or 100 scale D. C. Voltmeter will serve the purpose.

Connect two leads to the binding posts of the Voltmeter to be used, and terminate them in a phone plug which is then inserted in the Phonograph Pick-up Jack just far enough to touch the first inside contact. (See figure 2.) DO NOT PLUG ALL THE WAY INTO THE JACK, as this will short out the Detector tube biasing resistor, and cause inaccurate readings.) Be sure that no Analyzer Adapters are connected to the end of the Analyzer Cord, or plugged into the Analyzer Socket, as this will short-circuit the Voltmeter.

NOTE: (When aligning Models 235 and 103, two small battery clips instead of a phone plug are fastened to the Voltmeter leads. On the Model 235 the leads are connected to terminals No. 11 and No. 13 of the terminal block located on the left-hand side of the cabinet. On the Model 103 the leads are connected to terminals No. 14 and No. 17 on the terminal strip.)

1. With aerial and ground wires connected to the set as they are to be permanently used,

CALIBRATION OF DIAL STRIP ON SPARTON MODELS 103, 235, 410, 420, 564, 570, 574, 578, 589, 591, 593, 600, 610, 620, 740, 750 AND 870.

9. Note carefully whether or not a station around 600 kilocycles indicates correctly on the dial when tuned to the loudest volume.

10. If station reads off its proper setting, loosen the screws which hold the celluloid strip



PHONE PLUG INSERTED APPROXIMATELY 3/4 OF THE WAY INTO THE JACK OR JUST FAR ENOUGH TO OBTAIN A READING OF APPROXIMATELY 15 VOLTS WITH NO SIGNAL TUNED IN

SPARKS WITHINGTON CO.

MODEL 111-A, 574, 870
Schematic

SPARTON MODEL
574 AND 870
ALSO MODEL 111-A

DYNAMIC SPEAKER
FIELD MOVING
COIL

For Voltage Data
See Model 110 AC

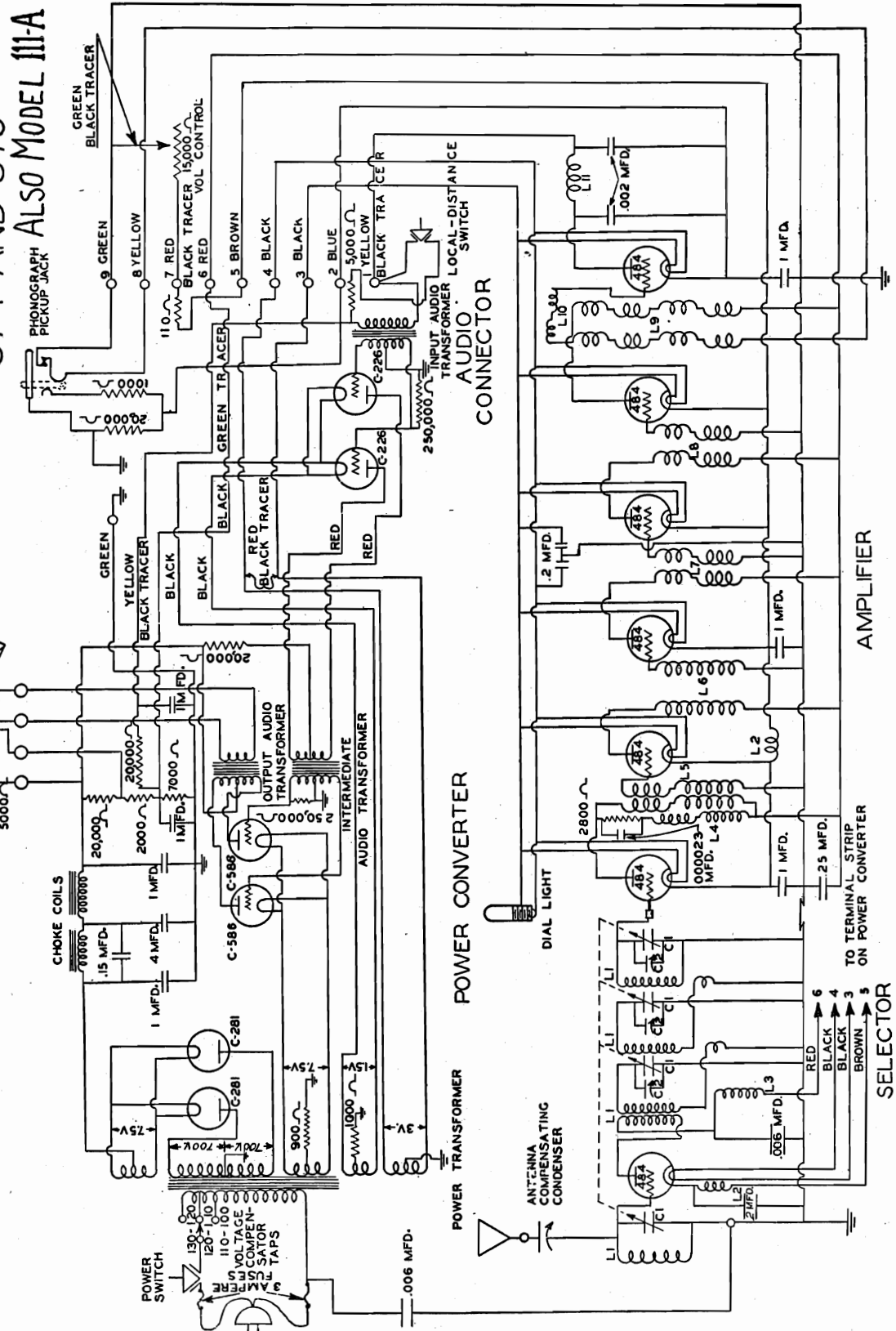

L9 FOURTH R.F. TRANSFORMER
L10 FREE GRID COIL
L11 DETECTOR PLATE CHOKE

L6 FIRST R.F. TRANSFORMER
L7 SECOND R.F. TRANSFORMER
L8 THIRD R.F. TRANSFORMER

L3 R.F. CHOKE COIL
L4 FIRST PLATE COIL
L5 COUPLING COIL

C1 VARIABLE CONDENSERS
C2 EQUALIZING CONDENSERS
L1 TUNING COILS
L2 CATHODE COILS

MODEL 301 DC

SPARKS WITHINGTON CO.

Voltage Readings:

- 115 volt line with switch set at "Lo".
- 182 plate volts—115.
- 182 "C" voltage 22.5. (Across terminals)
- 182 filament volts 4 to 4.5.
- 484 volts—18 volts (voltage across 6 tubes in series)
- Detector plate volts (volume on) 3-4
- 100 to 108 volts. 1-2
- 112 volts 5-6
- R. F. plate volt (volum on) 105 to 2-9
- Detector "C" volt 8 to 10 volt. 5-9
- R. F. "C" volts (volume on) 2 to 3 v.

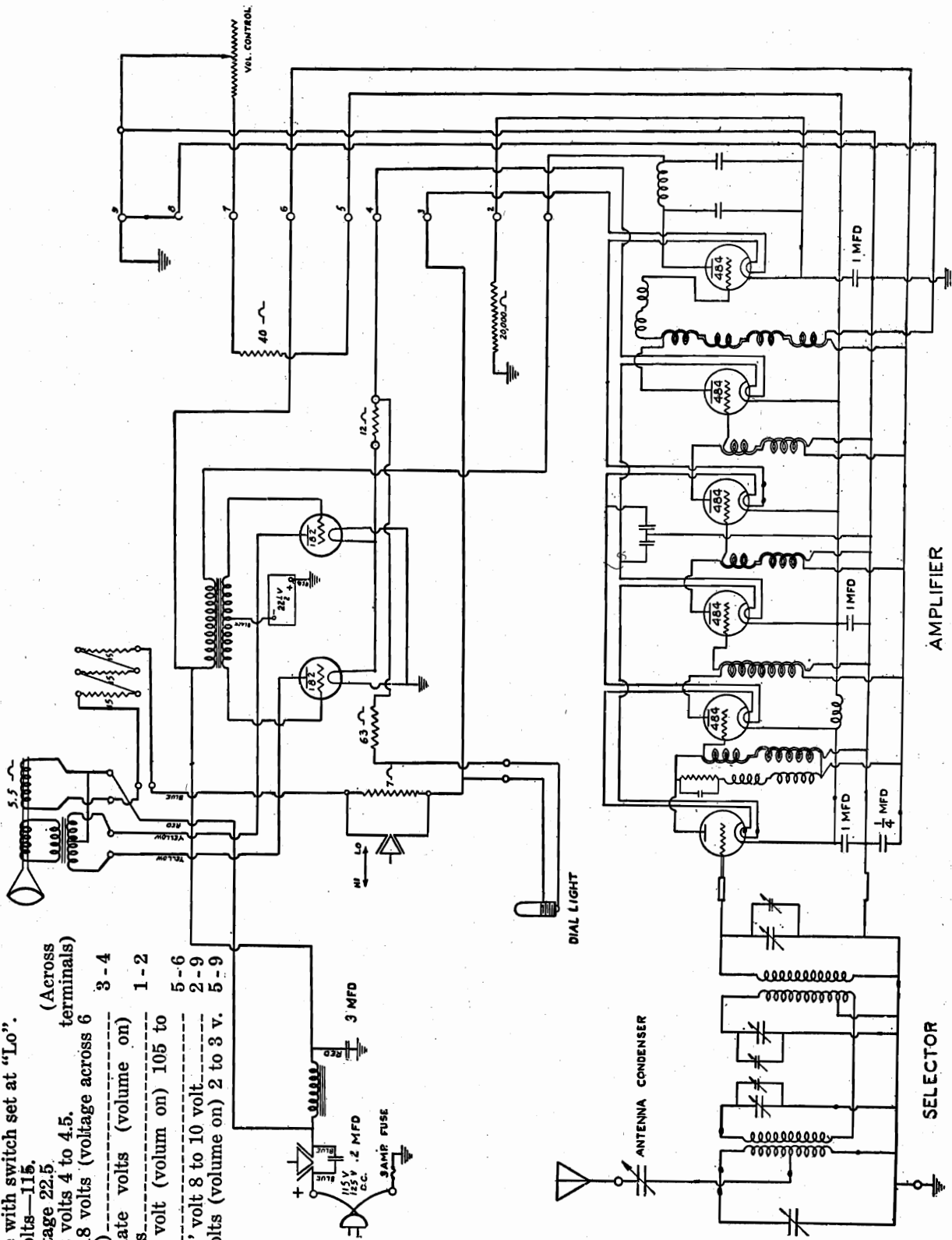

AMPLIFIER

SELECTOR

SPARKS WITHINGTON CO.

MODEL 420 AC
Schematic

SPARTON MODEL
410 AND 420 A.C. RECEIVER
JUNIOR JETBALL

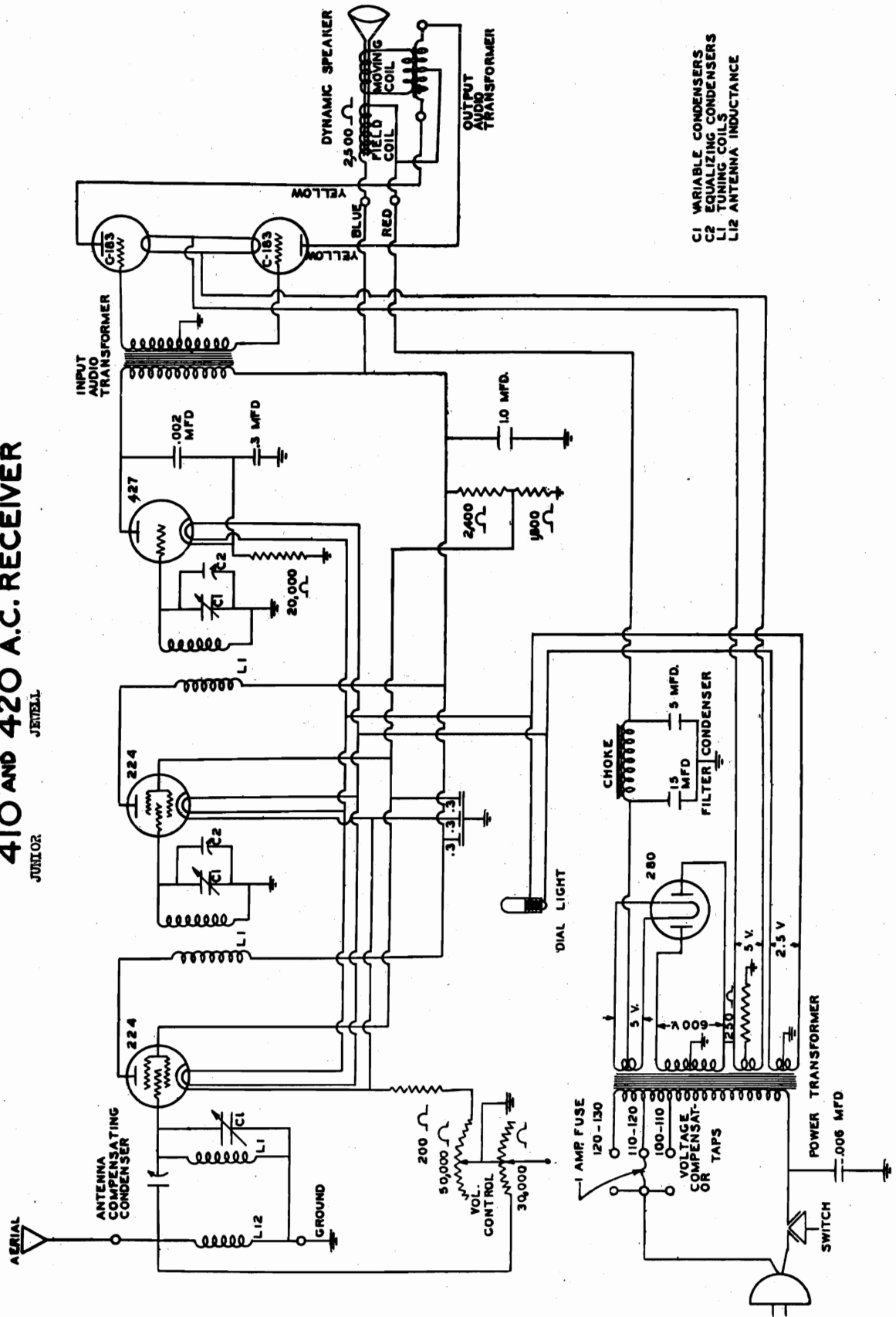

C1 VARIABLE CONDENSERS
C2 EQUALIZING CONDENSERS
L1 TUNING COILS
L2 ANTENNA INDUCTANCE

MODEL 420 DC
Chassis

SPARKS WITHINGTON CO.

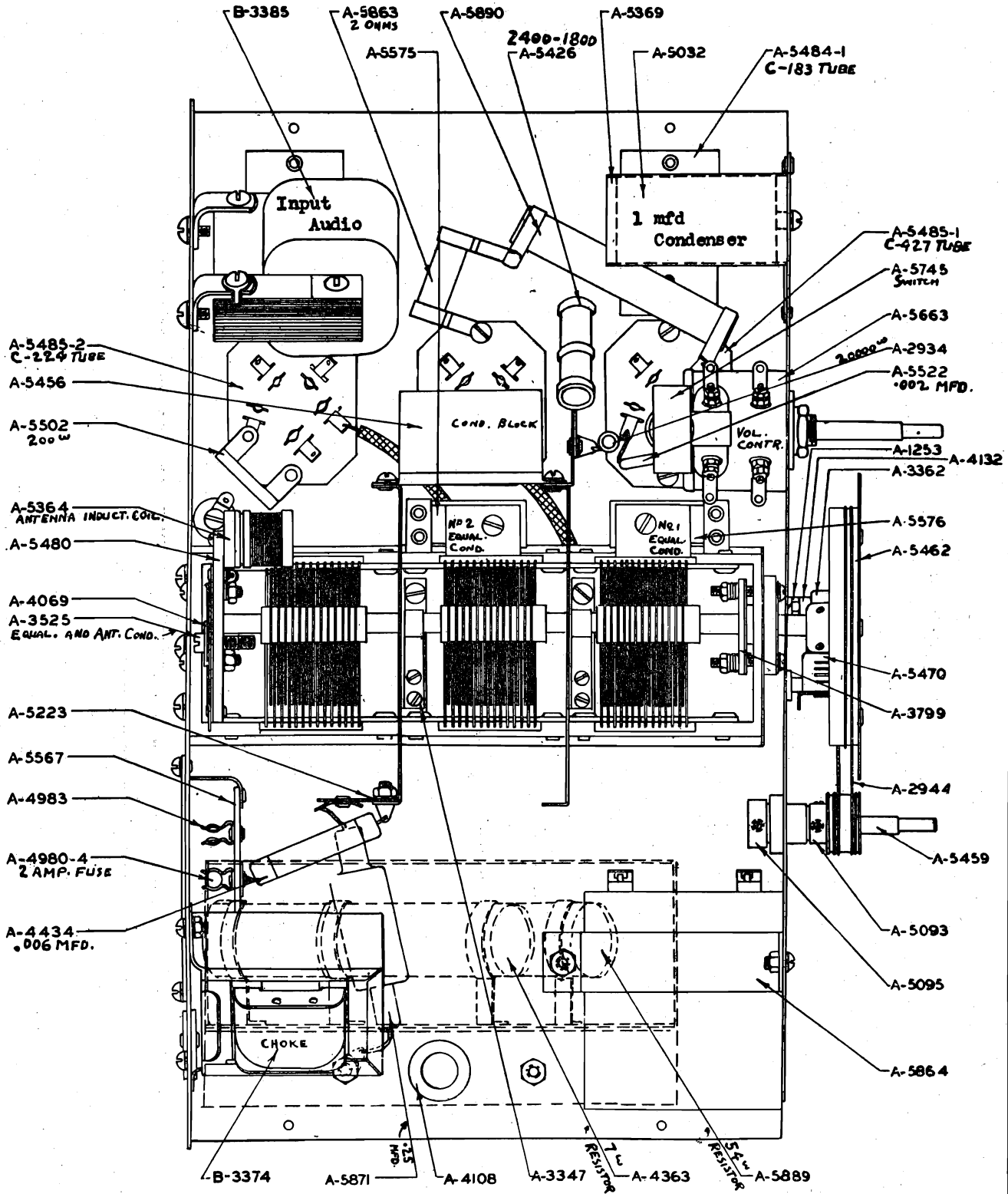

Bottom View—Model 410 and 420 D. C. Chassis

SPARKS WITHINGTON CO.

Resistor
Color Code

Standard Resistor Color Code and Resistors Used In Sparton Radio Receiving Sets and Sparton Ensembles

STANDARD RESISTOR COLOR CODE

0—Black	5—Green
1—Brown	6—Blue
2—Red	7—Violet
3—Orange	8—Gray
4—Yellow	9—White

To determine the value of a resistor, the first significant figure of resistance value is represented by the color of the body of the re-

sistor, and the second figure of resistance value by the color of the tip of the resistor. The number of ciphers following the second figure is determined by the color of the dot or stripe in the center of the body of the resistor. For example, a 20,000 ohm resistor has a red body, black tip, with orange dot or orange stripe. A 2,200 ohm resistor would be red body, with red tip and red dot, or red stripe, and as all colors are the same, it would be a single color resistor.

SPARTON PART NO.	RESISTANCE, OHMS	SIZE, WATTS	OLD COLOR	STANDARD RESISTOR COLOR CODE		
				BODY	TIP	DOT OR STRIPE
A-2934	20,000	2	Green	Red	Black	Orange
A-3397	1,000	2	Tan	Brown	Black	Red
A-3397-X	1,000	0.5	Tan	Brown	Black	Red
A-3423	50,000	2	Red	Green	Black	Orange
*A-3750	1,250	3	Black, Silver Ends	Brown	Orange	Red
A-4107	15,000	5	Black, Silver Ends	Brown	Green	Orange
A-4234	250,000	5	Brown, Blue Ends	Red	Green	Yellow
A-4261	20,000	1	Green	Red	Black	Orange
A-4353	2,800	0.5	Gray	Red	Gray	Red
A-4613	1,700	1	Brown	Brown	Violet	Red
A-4614	10,000	1	Blue	Brown	Black	Orange
A-5139	30,000	1	Red	Orange	Black	Orange
A-5180	5,000	15	Green	Green	Black	Red
A-5269	500,000	1	Green	Black	Black	Yellow
A-5270	250,000	1		Red	Green	Yellow
A-5354	100,000	1		Brown	Black	Yellow

*1250 ohm resistors same color scheme as 1300 ohm resistors.

Standard Resistor Color Code Is Not Applied to Vitreous Enamel Resistors

SPARTON PART NO.	RESISTANCE OHMS	SIZE WATTS	COLOR	SPARTON PART NO.	RESISTANCE OHMS	SIZE WATTS	COLOR
A-4363	7	20	Blue	A-4365	15	50	Blue
A-4364	12	30	Blue	A-5177	160	1	Blue
A-4365	63	10	Blue	A-5426	2,400-1,800	8	Blue
A-5889	54	175	Blue	A-5990	14	6	Blue

Standard Color Code Is Not Applied to Wire Wound Resistors

SPARTON PART NO.	RESISTANCE OHMS	SIZE, WATTS	COLOR	SPARTON PART NO.	RESISTANCE OHMS	SIZE, WATTS	COLOR
A-3383	3,000	10	Black	A-4915	110	1	Black
A-3535	7,000	10	Black	A-4974	1,250	5	Gray
A-3536	900	10	Black	A-5137	330	1	Gray
A-3811	30,000	0.5	Black	A-5502	200	1	Red
A-4260	7,000-2,000	20	Black	A-5861	57	175	Blue
A-4363	7	20	Black	A-5862	12	10	Blue
A-4583	7,000	10	Black	A-5863	2	5	Blue
A-4670	110	1	Black				

MODEL 591, 593 AC

SPARKS WITHINGTON CO.

**SPARTON MODELS
591 AND 593 RECEIVER**

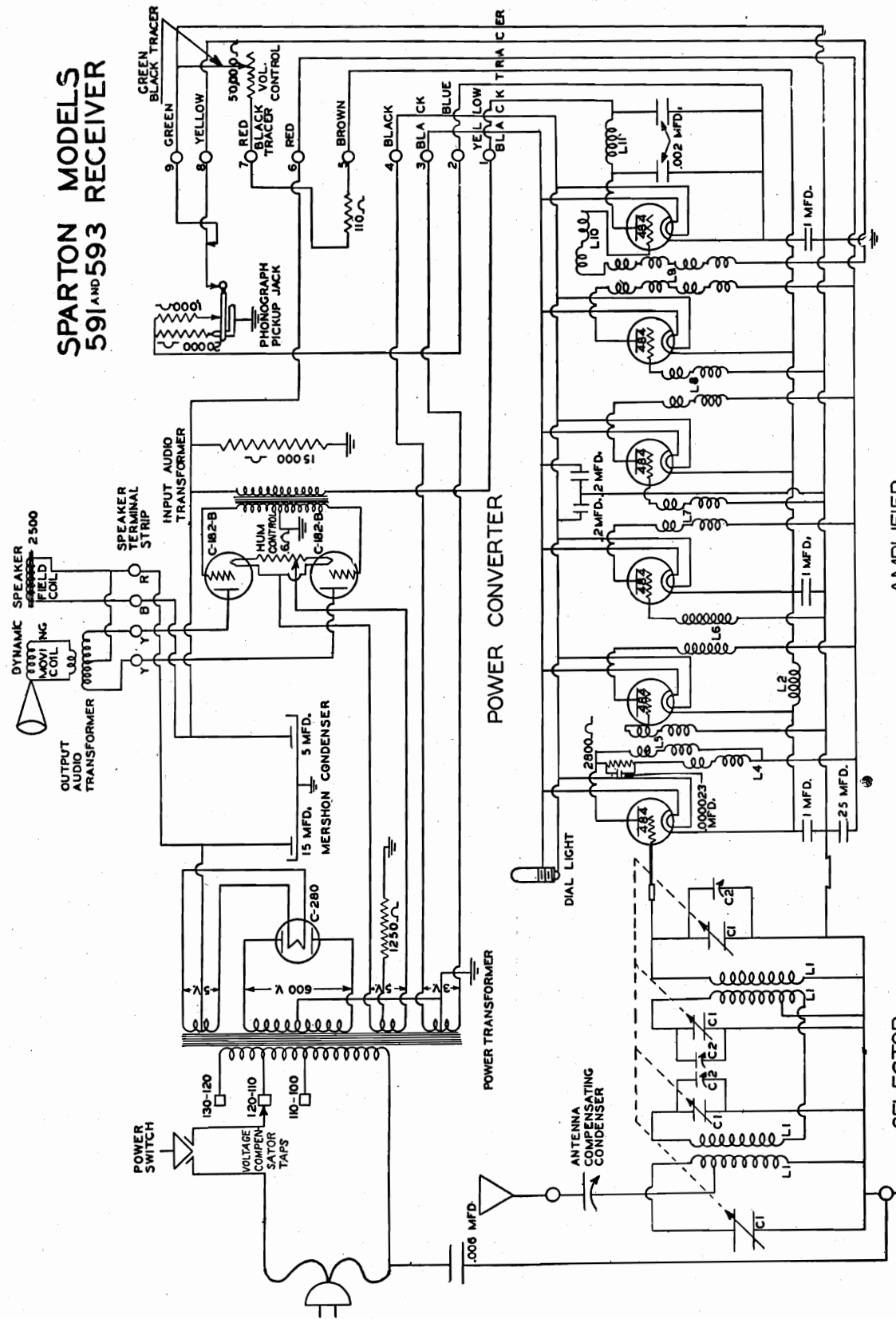

AMPLIFIER

SELECTOR

For Voltage Data See Model 589

- C1 VARIABLE CONDENSERS
- C2 EQUALIZING CONDENSERS
- L1 TUNING COILS
- L2 CATHODE COIL
- L3 FIRST PLATE COIL
- L4 FIRST PLATE COIL
- L5 COUPLING COIL
- L6 FIRST R.F. TRANSFORMER
- L7 SECOND R.F. TRANSFORMER
- L8 THIRD R.F. TRANSFORMER
- L9 DETECTOR PLATE CHOKE
- L10 FREE GRID COIL
- L11 FOURTH R.F. TRANSFORMER

SPARKS WITHINGTON CO.

MODEL DC 564,570
600,610,620,740 and 750 D.C.
740,750

SPARTON MODELS
600, 610, 620, 740 and 750 D.C.
Also 564-570

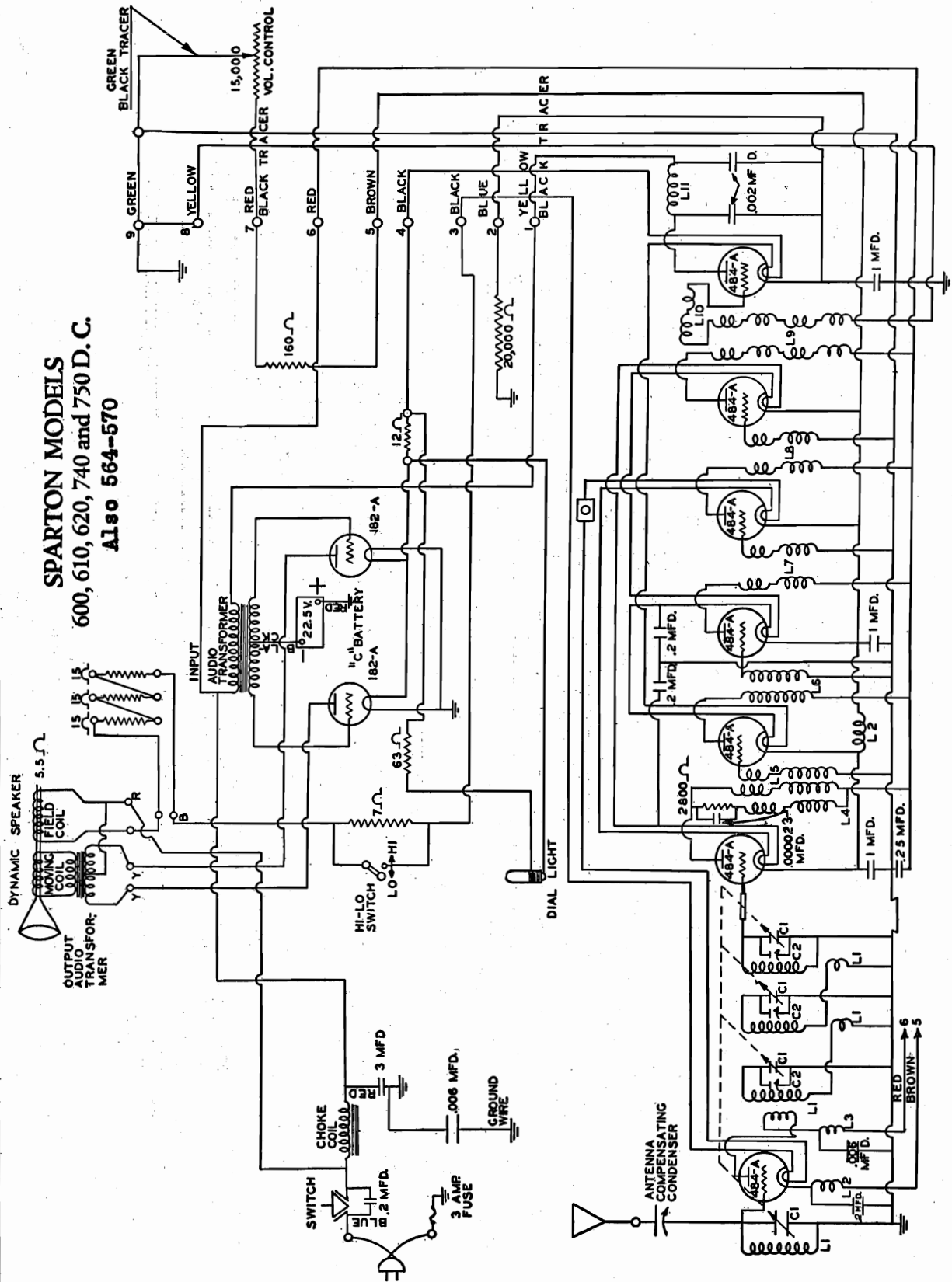

- C1 VARIABLE CONDENSERS
- C2 EQUALIZING CONDENSERS
- L1 TUNING COILS
- L2 CATHODE COILS
- L3 R.F. CHOKE COIL
- L4 FIRST PLATE COIL
- L5 COUPLING COIL
- L6 FIRST R.F. TRANSFORMER
- L7 SECOND R.F. TRANSFORMER
- L8 THIRD R.F. TRANSFORMER
- L9 FOURTH R.F. TRANSFORMER
- L10 GRID COIL
- L11 DETECTOR PLATE CHOKE

Power Converter

SPARKS WITHINGTON CO.

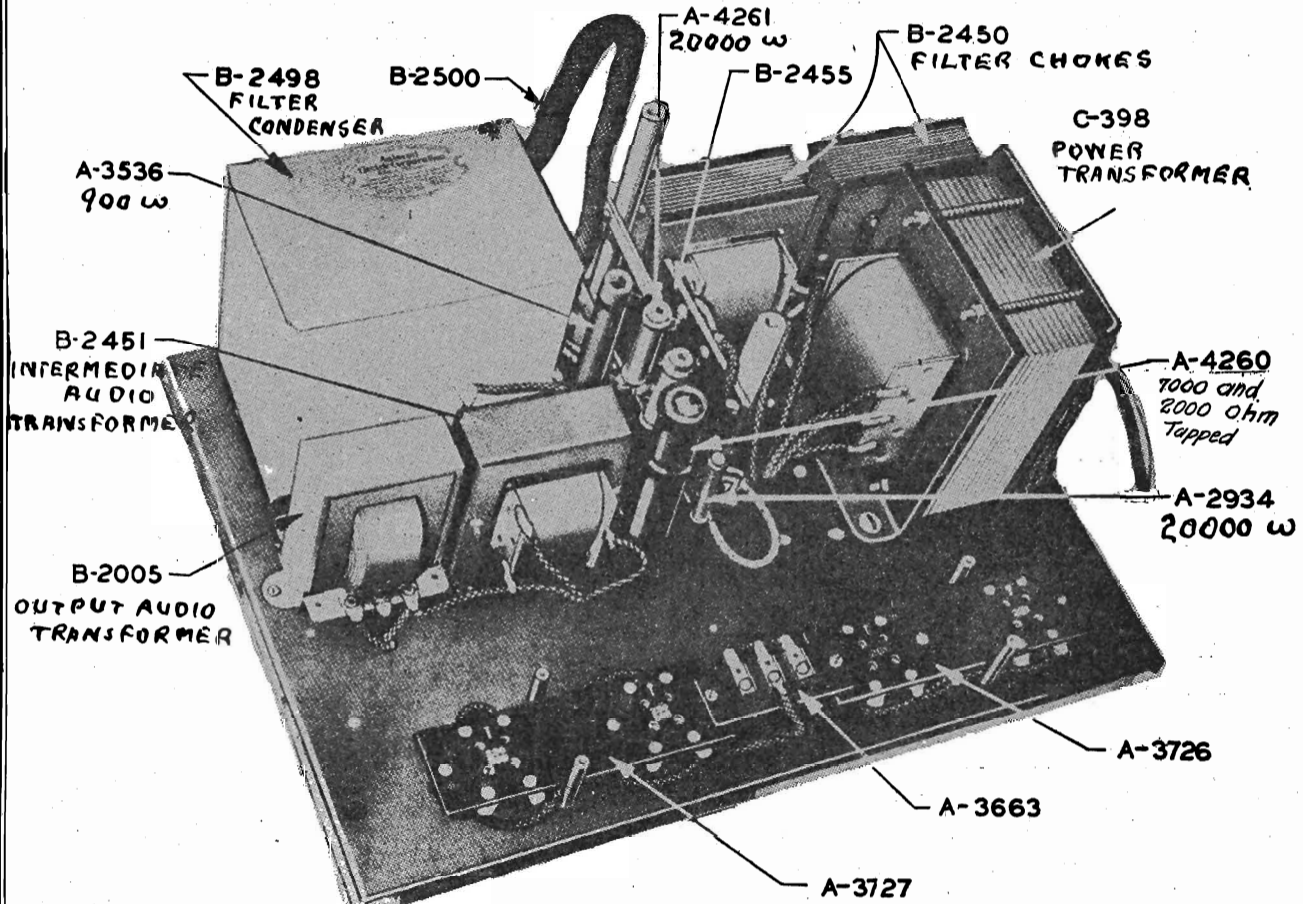

Inside View—Power Converter, Models 111-A and 870 A. C. ALSO 574

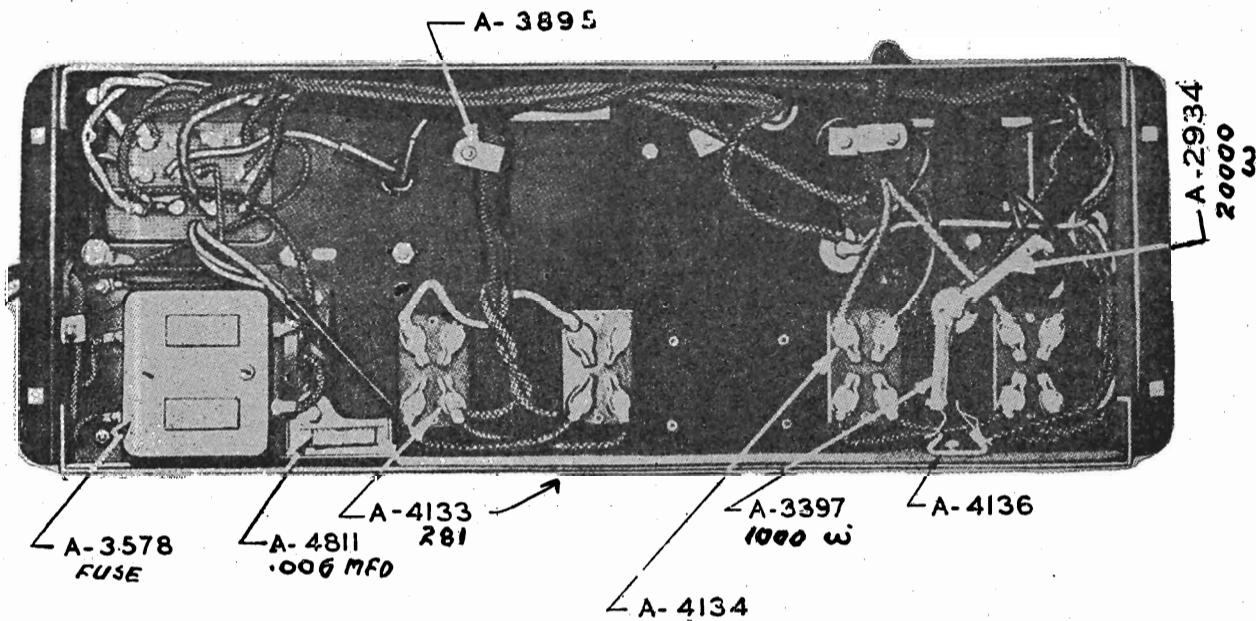

Bottom View—Power Converter, Models 103, 301-A, 578, 740 and 750 A. C.

SPARKS WITHINGTON CO.

Selector Unit

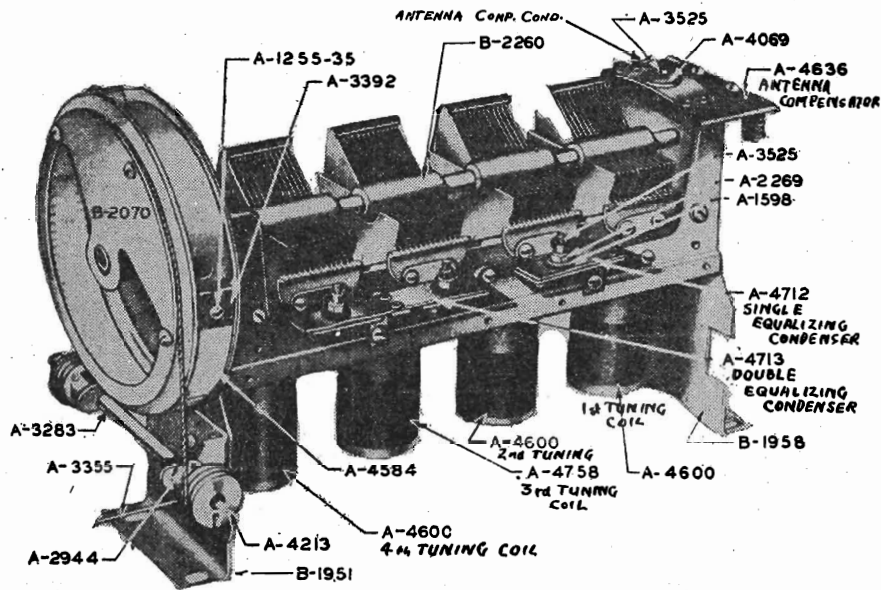

Inside View—Selector Unit Models 301, 591, 593 and 931 A. C. and D. C.

Note: D. C. Models use A-4388 Antenna Compensating Condenser.

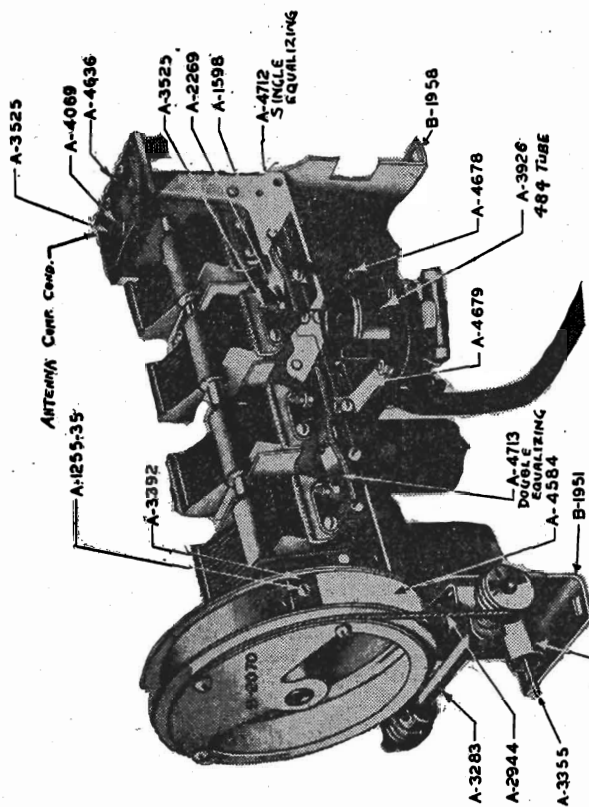

Top View—Selector Unit, Models 103, 111-A, 235, 301-A, 564, 570, 574, 578, 589, 600, 610, 620, 737, 740, 750 and 870 A. C. and D. C.

Note: D. C. Models use A-5276 Antenna Compensating Condenser.

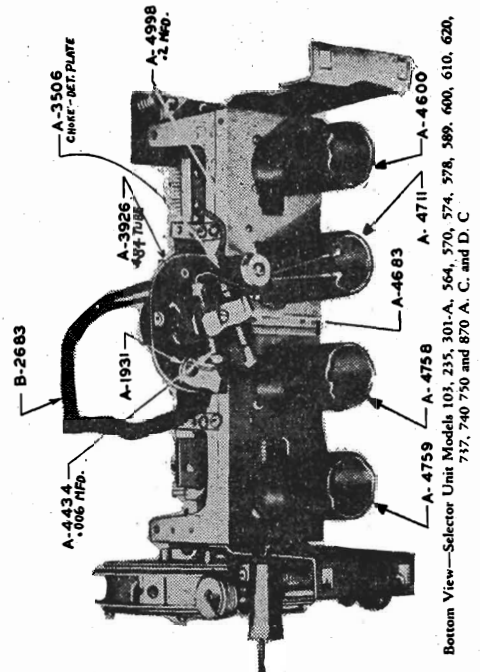

Bottom View—Selector Unit Models 103, 235, 301-A, 564, 570, 574, 578, 589, 600, 610, 620, 737, 740, 750 and 870 A. C. and D. C.

**Amplifier Unit
Connector Unit**

SPARKS WITHINGTON CO.,

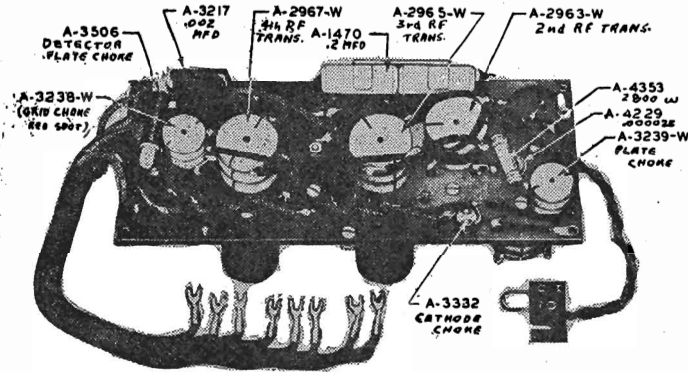

(Left) Bottom Inside View of Amplifier Unit - Models 103 - 111A- 235- 301- 301A- 564- 570- 578- 589- 600- 610- 650- 737- 740- 750- 870- and 931 AC and DC.

(Right) Top Inside View of Amp-
lifier Unit- Models 103- 111A- 235-
301- 301A- 564- 570- 574- 578- 589-
591- 593- 600- 610- 620- 737- 740-
750- 870- 931 AC and DC.

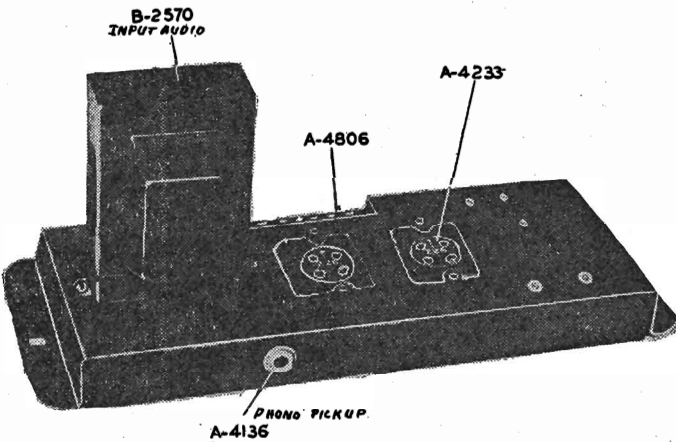
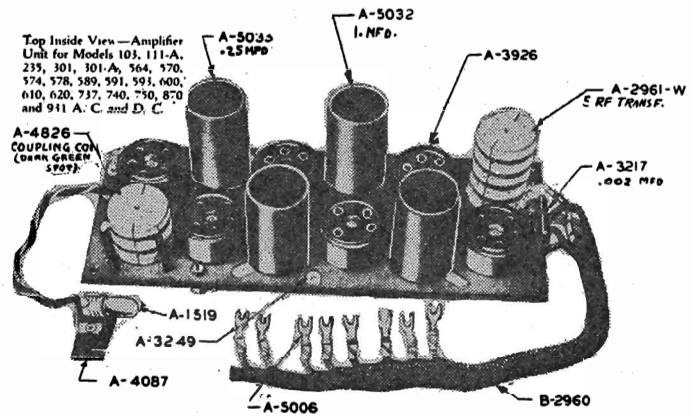

Top View—Connector Unit, Models 111-A and 870 A. C.

(Left) Top View of Connector Unit
for Models 111A and 870
AC

(Right) Bottom View of Connector
Unit for Models 111A- 574- 870 AC

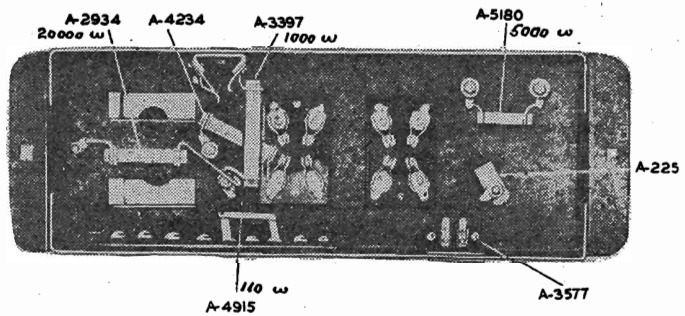

Bottom View—Connector Unit, Models 111-A and 870 A. C.
ALSO 574

SPARKS WITHINGTON CO.

Power Converter

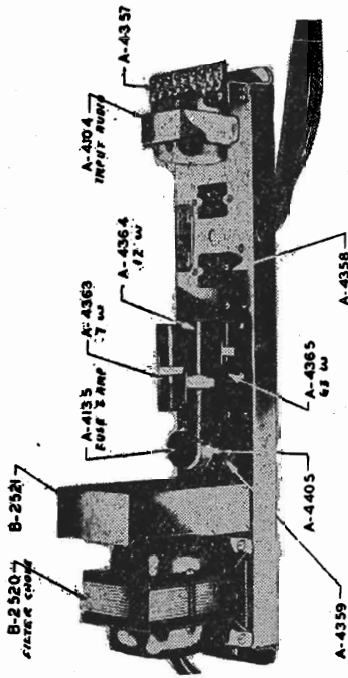

Top View—Power Converter, Models 215, 600, 610, 620, 737, 740, 750 D. C.

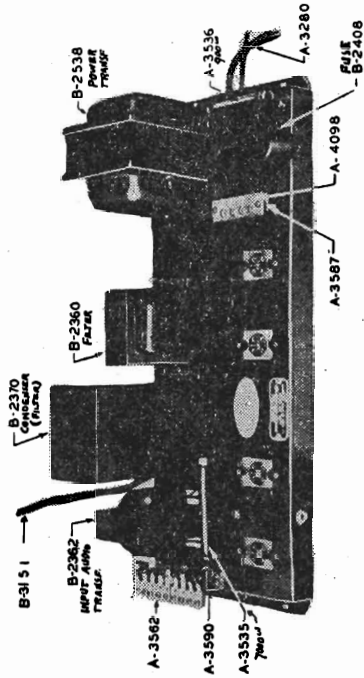

Top View—Power Converter—Models 101, 301-A, 578, 740 and 750 A. C.

Note: Models 103 and 578 use 302-121B cable instead of B-3151, and B-2120 Filter Condenser instead of B-2370, A-1562 Terminal Block, and A-3590 Terminal Block Brackets are not used

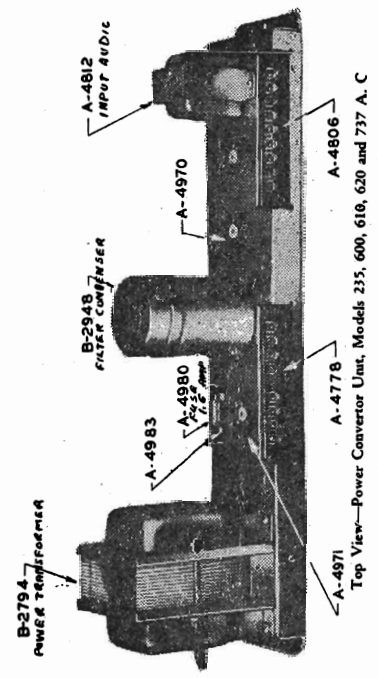

Top View—Power Converter Unit, Models 235, 600, 610, 620 and 737 A. C.

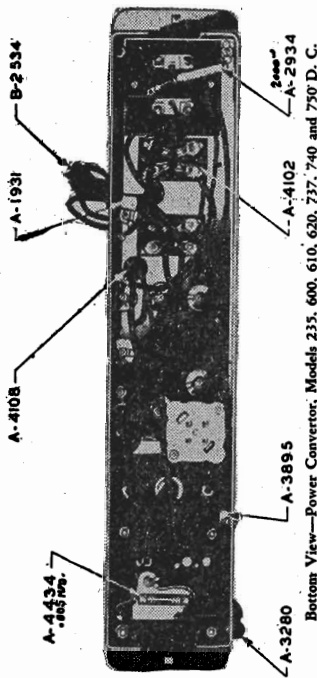

Bottom View—Power Converter, Models 235, 600, 610, 620, 737, 740 and 750 D. C.

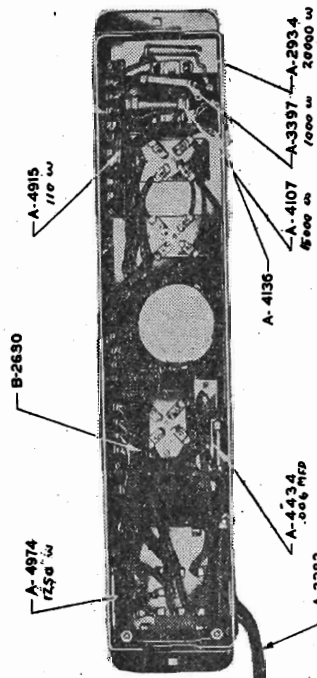

Bottom View—Power Converter, Models 215, 600, 610 and 620 A. C.

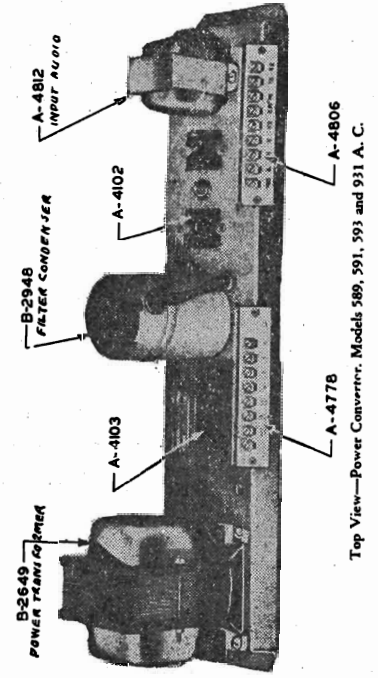

Top View—Power Converter, Models 589, 591, 593 and 931 A. C.

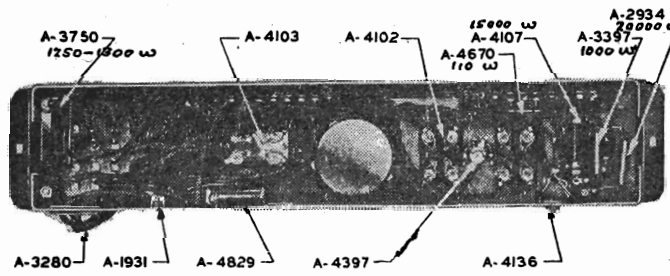

Bottom View—Power Converter, Models 589, 591, 593 and 931 A. C.

Sparton
Tube Data

SPARKS WITHINGTON CO.

Characteristics of Sparton Tubes

Type	Base	Use	"A" Supply	Filament Voltage	Filament Current Amperes	Detector Plate Voltage	Detector Plate Current Milli-Amps	Amplifier Plate Voltage	Grid Voltage	Amplifier Plate Current Milli-amps	Plate Impedance Ohms	Mutual Conductance Micromhos	Amplification Factor
C-112-A	Standard 4 prong	Power Amplifier	Stor. 6 volt Transformer 5 volts	5.0	0.25	-----	-----	135 157.5 180	-9.0 -10.5 -13.5	7.0 9.5 7.8	5000 4700 4700	1600 1700 1700	8.0
C-181	Side Pin 4 prong	Power Amplifier	Transformer 3 Volts	3.0	1.3	-----	-----	200	-40	16	2850	1050	3.0
C-182	Standard 4 prong	Power Amplifier	Transformer 5 Volts	5.0	0.9	-----	-----	200	-45	18	2000	1500	3.0
C-182-A	Standard 4 prong	Direct Current Power Amplifier	Transformer 5 Volts	5.0	0.8	-----	-----	200	-45	18	2000	1500	3.0
C-182-B	Standard 4 prong	Power Amplifier	Transformer 5 Volts	5.0	1.25	-----	-----	200	-29	18	3330	1500	5.0
C-183	Standard 4 prong	Power Amplifier	Transformer 5 Volts	5.0	1.25	-----	-----	200	-45	20	2000	1500	3.0
C-210	Standard 4 prong	Power Amplifier	Transformer 7.5	7.5	1.25	-----	-----	350	-27	20	5500	1450	8.0
C-231	Standard 4 prong	Power Amplifier	6 dry cells Series Parallel	2.0	0.150	-----	-----	135	-22.5	8.0	4000	875	3.5
C-245	Standard 4 prong	Power Amplifier	Transformer 2.5	2.5	1.5	-----	-----	180 250	-33 -50	26 32	1460 2250	2400 1450	3.5
C-586	Standard 4 prong	Power Amplifier	Transformer 7.5	7.5	1.25	-----	-----	250 350 450	-45 -63 -84	28 45 55	2150 2000 1950	1575 1700 1750	3.4
C-201-A	Standard 4 prong	Detector Amplifier	Storage 6 volts	5.0	.25	45	1.5	90 135	-4.5 -9.0	2.5 3.0	11000 10000	725 800	8.0
C-230	Standard 4 prong	Detector Amplifier	6 dry cells Series Parallel	2.0	0.060	45	1.5	90	-4.5	2.0	12500	700	8.8
C-401	Side Pin 4 prong	Detector Amplifier	3 Volts	3.0	1.3	45	2	90 120	-3 -4	5.0 6.0	9500 7000	1000 1200	9.5 8.7
C-427	Standard 5 prong	Detector Amplifier	2.5 Volts	2.5	1.75	180	0.8	90	-3	5.0	10800 9300	1150	12.5
C-484	Standard 5 prong	Detector Amplifier	3 Volts	3.0	1.3	135	0.8	90 120	-3 -4	5.0 6.0	10800 9300	1150 1350	12.5
C-484-A	Standard 5 prong	Direct Current Detector Amplifier	3 volts D. C.	3.0	1.6	100	0.5	90 120	-3 -4	5.0 6.0	9300	1150 1350	12.5
C-226	Standard 4 prong	Amplifier	1.5 Volts	1.5	1.05	-----	-----	180	-13.5	6.0	7000	1170	8.2
C-686	Standard 5 prong	Amplifier	Storage 6 volts	3.0	.25	-----	-----	90	-3.0	3.0	28000	450	12.5
C-224	Standard 5 prong	Screen Grid Amplifier	Storage 6 Volt Transformer 2.5 Volt	2.5	1.75	Screen Grid Voltage Plus 90	-----	180	-3.0	4.0	400000	1000	400
C-232	Standard 4 prong	Screen Grid Amplifier	6 dry cells Series Parallel	2.0	0.060	Screen Grid Voltage Plus 67.5	-----	135	-3.0	1.5	800000	550	440
C-280	Standard 4 prong	Full Wave Rectifier	5.0 Volts	5.0	2.0	Max. A. C. Voltage per plate 350 Volts R. M. S. Max. Rectified Current 125 M. A.							
C-281	Standard 4 prong	Half Wave Rectifier	7.5 Volts	7.5	1.25	Max. A. C. Voltage per plate 700 R. M. S. Max. Rectified Current 85 M. A.							

MODEL 421,425
(Chassis 21)
Voltage, Chassis

STEINITE RADIO CO.

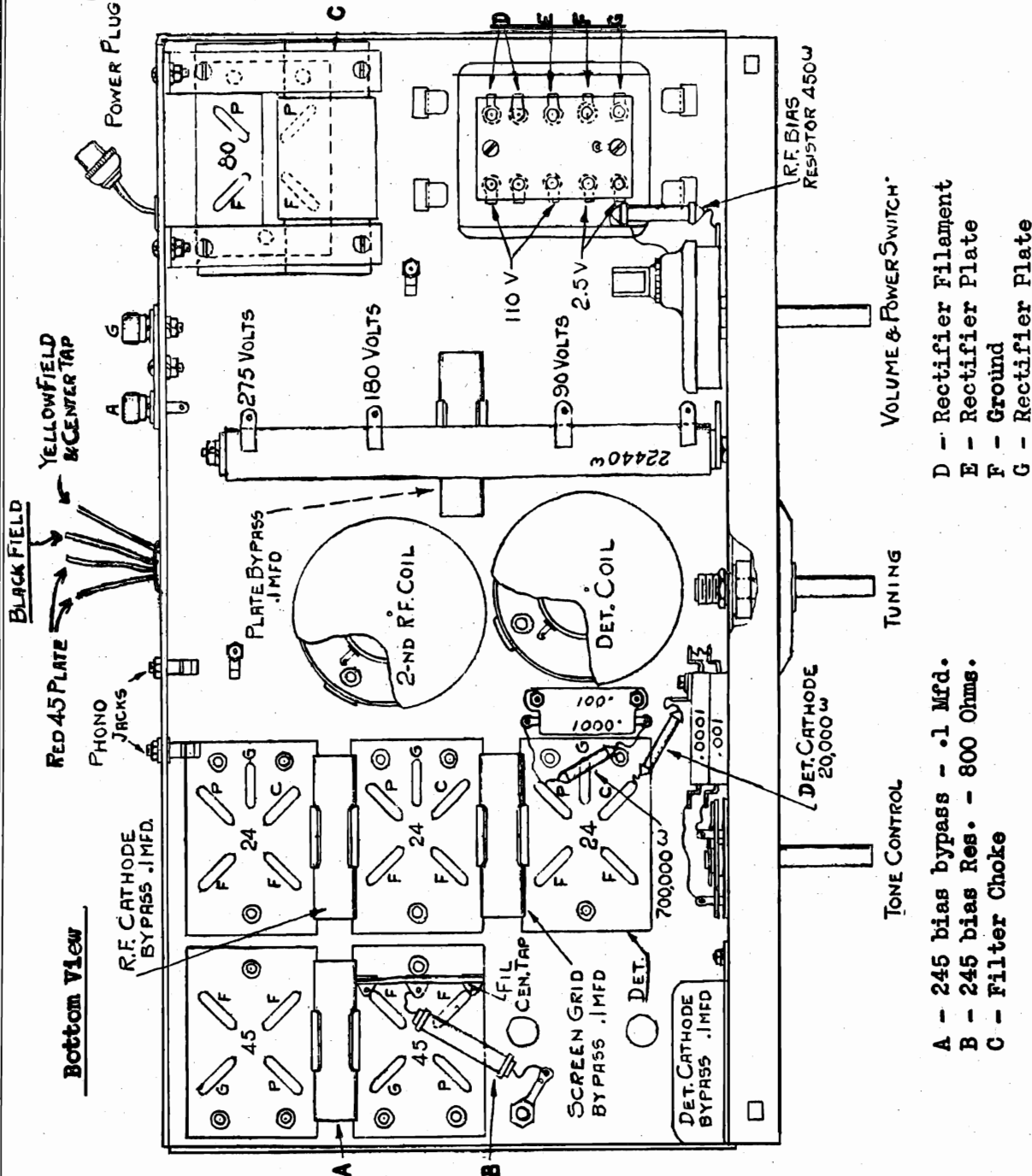

D - Rectifier Filament
E - Rectifier Plate
F - Ground
G - Rectifier Plate

A - 245 bias bypass - .1 Mfd.
B - 245 bias Res. - 800 Ohms.
C - Filter Choke

Readings obtained with
Line Volt. = 110
Vol. Cont. Max.

'24 and '45 filaments	-----	2.2 v
'80 filament	-----	4.5 v
R.F. screen grids (to ground)	-----	90 v
R.F. plates (to ground)	-----	180 v
Detector Plate (to ground)	-----	250 v
Detector screen grid (to ground)	-----	90 v
R.F. Cathode to ground	-----	
Volume Control Maximum	-----	3 v
Volume Control minimum	-----	10 v
Detector Cathode (to ground)	-----	10 v
'45 plate (to ground)	-----	275 v
All filaments to ground	-----	40 v

STEINITE RADIO CO.

MODEL 423
(Chassis 23)
Schematic

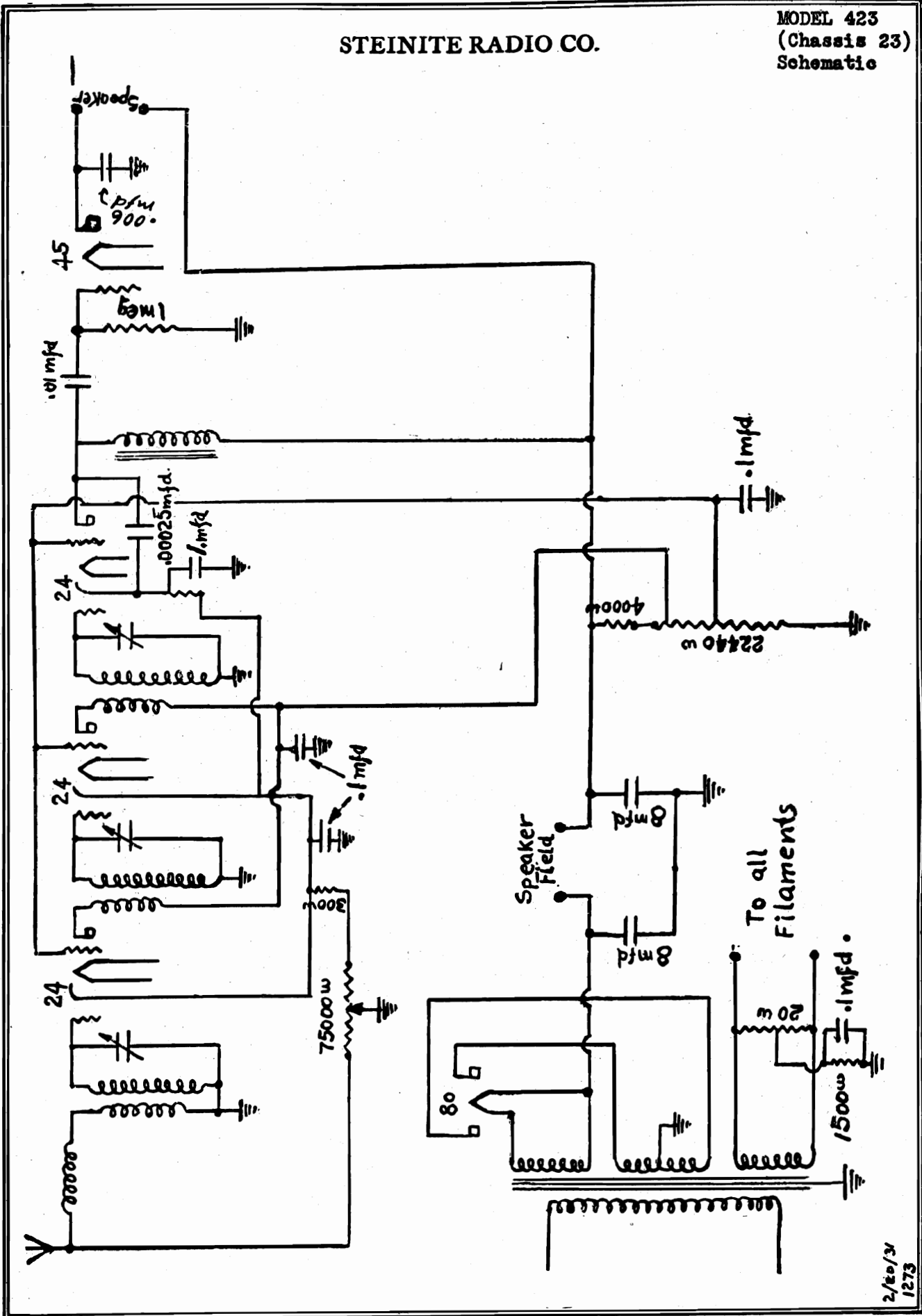

2/80/3
1273

MODELS 700,705
706,725,642-B

STEINITE RADIO CO.

(Chassis 26)
Voltage, Data

° If a 175 kilocycle oscillator is available, the receiver may be aligned as follows: (all aligning operations should be made with bottom plate under act)

The output of the 175 K.C. oscillator is connected to the grid of the 1st detector tube and 125 m.a. thermo couple output meter is connected to the voice coil of the loud speaker. The two aligning condensers of each I.F. transformer should then be carefully adjusted for maximum output. These four condensers should be adjusted several times to be certain that all four circuits are tuned to exactly 175 K.C. (Use an insulated screw driver.)

After this has been done a station operating on about 1400 K.C. or preferably a modulated oscillator should be tuned in with the antenna or lead from the oscillator connected to the grid of the R.F. amplifier tube. The tuning dial should be set to correspond to the signal being used. That is, if a 1400 K.C. signal is being used, turn the tuning dial to read 1400 K.C. Then adjust the aligning condenser of the middle section of the gang condenser until maximum output is obtained. The next step is to remove the lead from the grid of the R.F. tube and connect it to the antenna binding post. DO NOT CHANGE THE TUNING DIAL WHILE DOING THIS. Then adjust the aligning condenser on the R.F. section of the condenser (the section at the rear of the chassis) until maximum output is obtained. After this has been completed the receiver is properly aligned at high frequencies.

Next set the oscillator at 600 K.C. or tune in a station near this frequency with the lead from oscillator or the antenna connected to the grid of the R.F. tube. Then adjust the oscillator aligning condenser (mounted in lower center front of chassis) for maximum output. This should be carefully done and at the same time the tuning dial should be changed slightly to see if maximum output is obtained. If it is found necessary to change the oscillator trinning condenser greatly it is well to repeat the aligning operation at the high frequency mentioned above.

	R.F. 1st detector, and	
	I.F. plate to ground-----	250 volts
	R.F. 1st detector, and	
	L.F. screen to ground-----	90 volts
Readings obtained	R.F. and I.F. cathode to ground-----	3 volts
with	1st detector, cathode to ground-----	12 volts
Line Volt. = 110	Oscillator, plate to ground-----	90 volts
Vol.Cont. at Max.	2nd, detector, plate to ground-----	250 volts
	2nd, detector, cathode to ground-----	22 volts
	'47 plate to filament-----	250 volts
	'47 screen to filament-----	250 volts
	All filaments to ground-----	16.5 volts
	'51, '47, '27, and '24 filaments-----	2.4 volts
	'80 filament-----	4.7 volts

The following points should be checked if no signal are heard when a good set of tubes are used.

The oscillator may be checked for oscillation by reading the cathode voltage of the 1st detector. This is normally about 12 volts. Then touch the grid of the oscillator tube and if it is working properly the reading obtained on the cathode of the 1st detector will drop to about half the normal reading. If it is not oscillating various '27 tubes should be tried in the oscillator position and if still no oscillation is obtained connections in the oscillator circuit should be checked for continuity.

MODEL 700,701
(Chassis 28)
Schematic
Voltage

STEINITE RADIO CO.

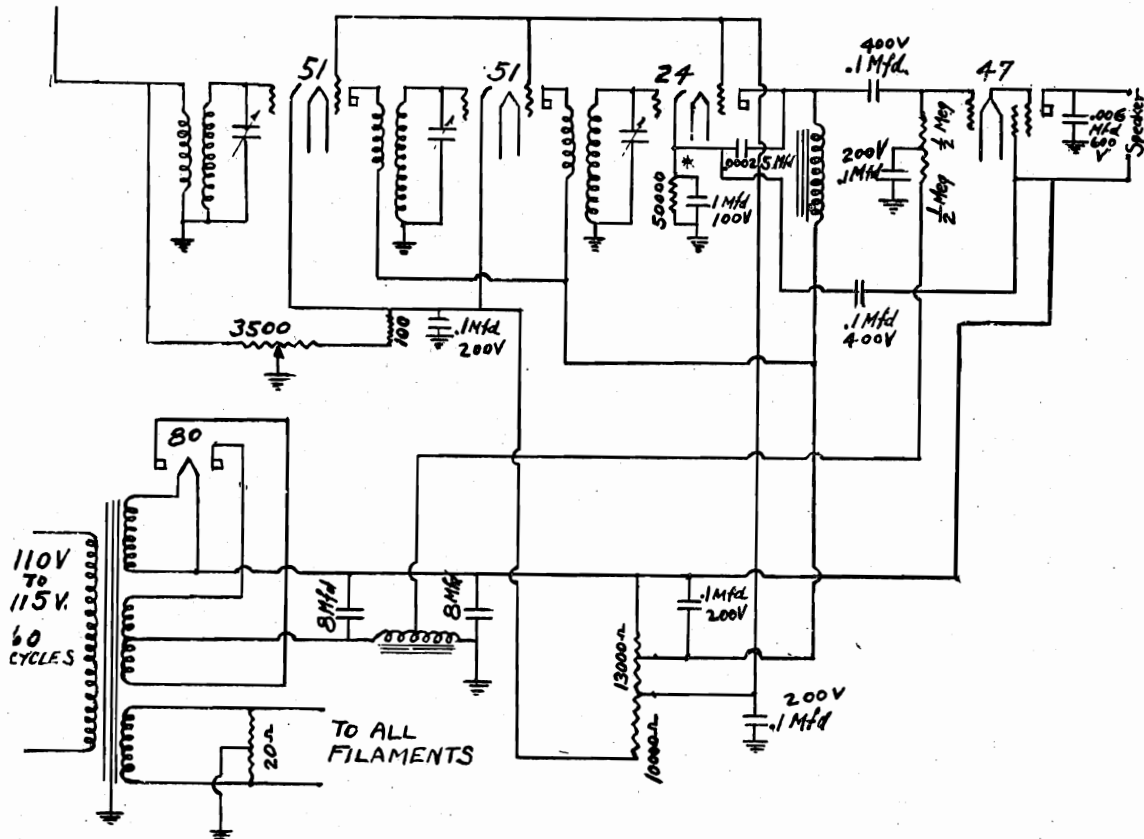

7/2/31
1323

It will be seen from the wiring diagram that a special impedance coupling is used from the power detector to the power pentode. If the set "motor boats", check opens in this circuit or short circuit in the coupling condenser.

All filaments except that of the type 80 tube are taken from one winding of the power transformer. Bias voltage for '47's is obtained from the drop across a portion of the speaker field. This maintains the grid at a 16.5 potential relative to ground. The grid is connected through two 1/2 meg. resistors, by-passed at center by a .1 mfd. condenser. Should this condenser become open, a very pronounced hum will result. In case of excessive hum or poor quality, check these connections.

'24 and '45 filaments-----	2.3
'80 filament-----	4.7
R.F. screen grids (to ground)-----	90
R.F. plates (to ground)-----	250
Detector plate (to ground)-----	250
Detector screen grid (to ground)-----	90
R.F. Cathode (to ground)	
Volume Control Maximum-----	3v
Volume Control Minimum-----	35
Detector Cathode (to ground)-----	10
'47 plate (to ground)-----	250v
'47 Screen (to ground)-----	250v
All filaments (to ground)-----	0v
Pentode Bias (at speaker field tap)-----	()--16.5v

Readings obtained with Line Volt.= 110 Vol. Cont. st Max.

STERLING MFG. CO.

MODEL R-100MV, R-403,
R-404, R-402,
R-406, R-407

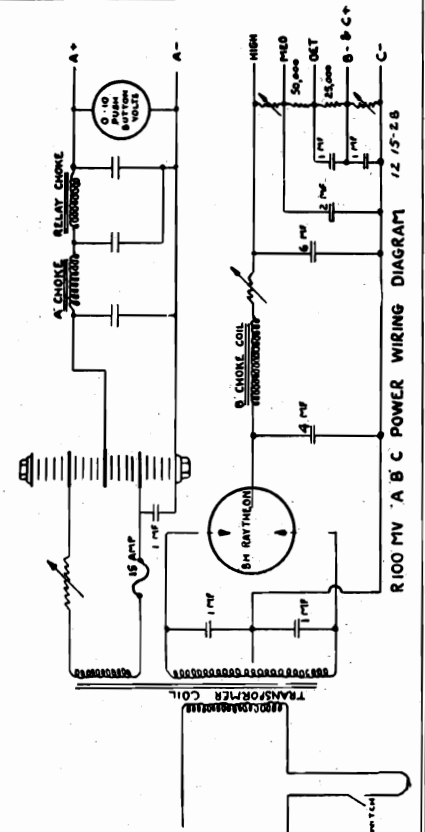
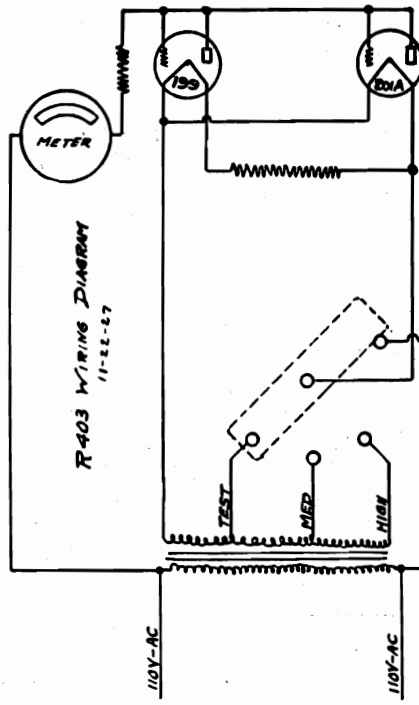
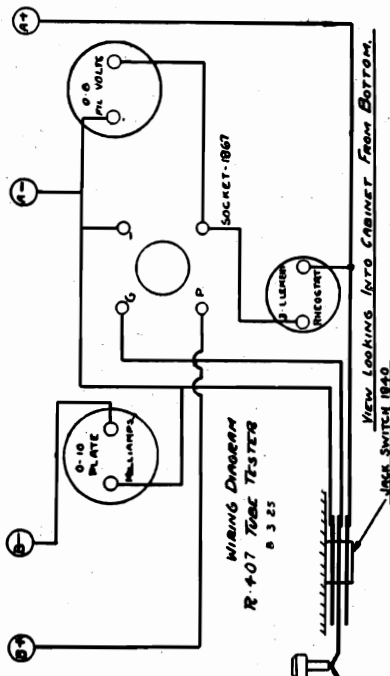
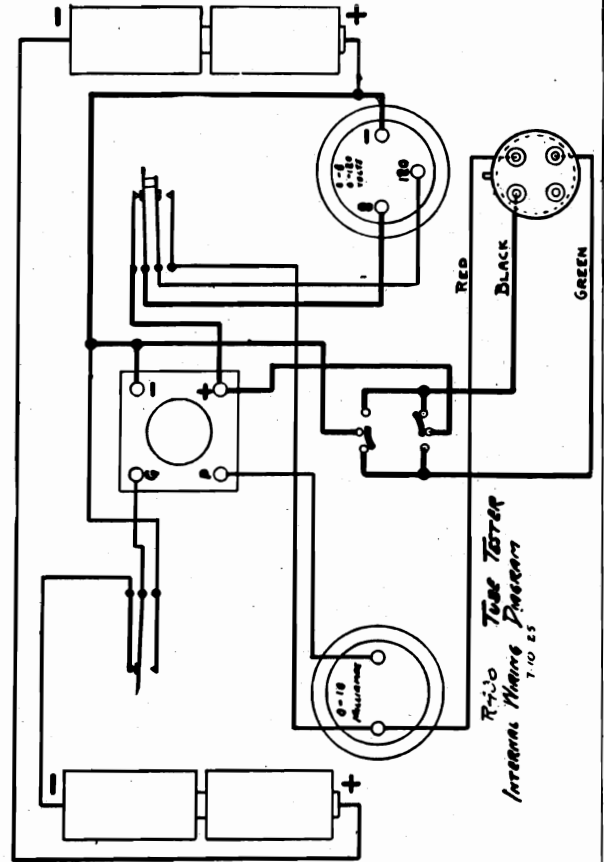
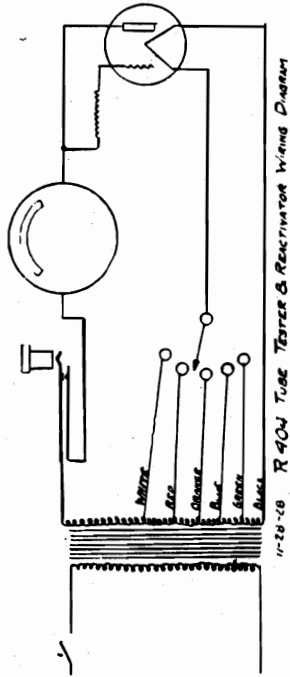
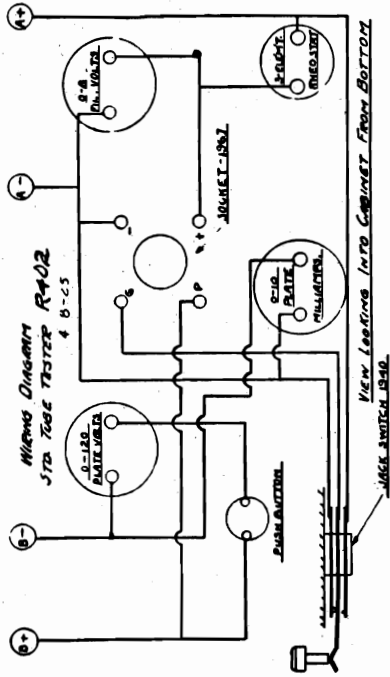

MODEL R-807A, R-810
(1st Type), R-810
(2nd Type), R-880.

STERLING MFG. CO.

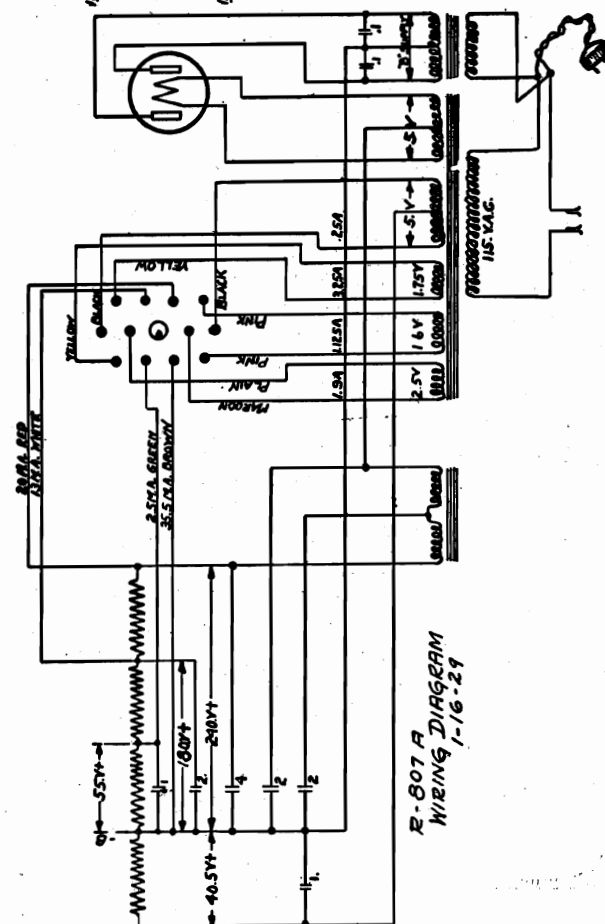
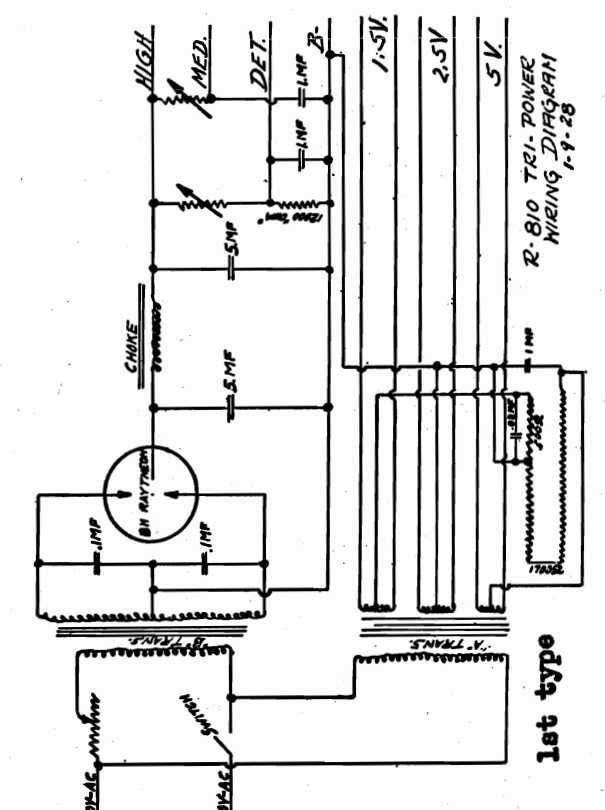
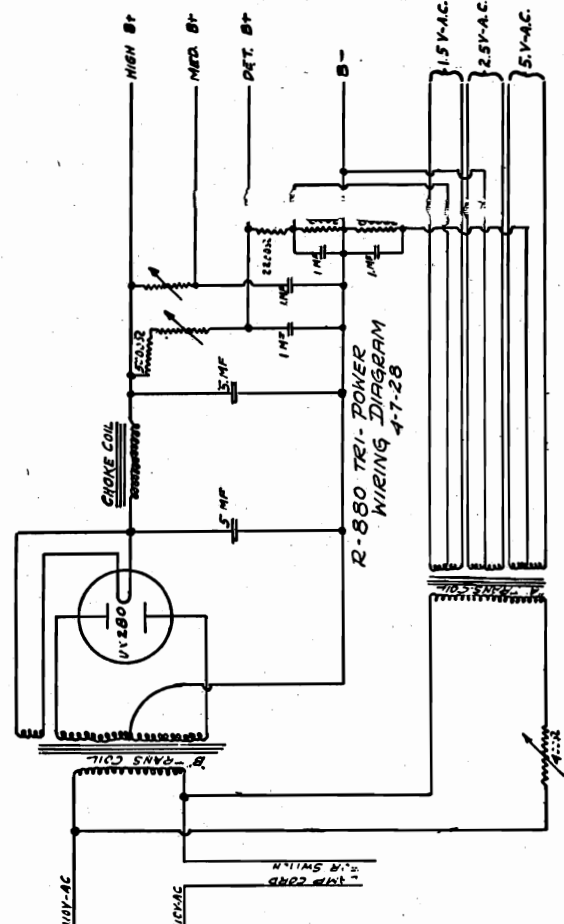
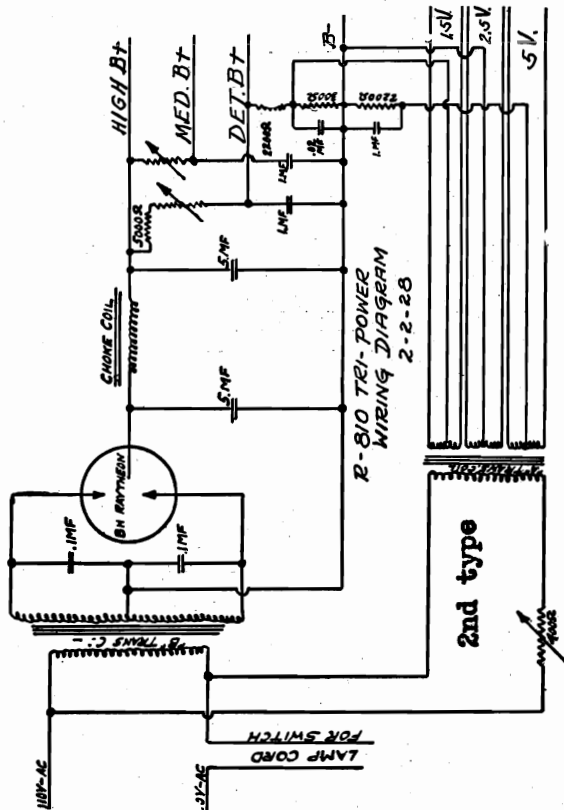

STERLING MFG. CO.

MODEL R-409, R-410, R-411, R-412, R-509, R-510

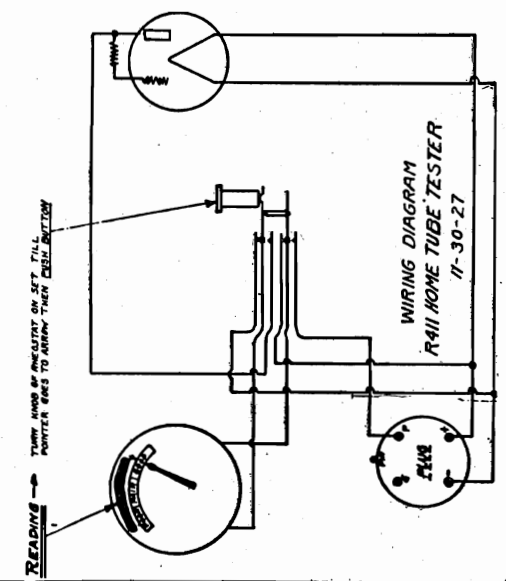
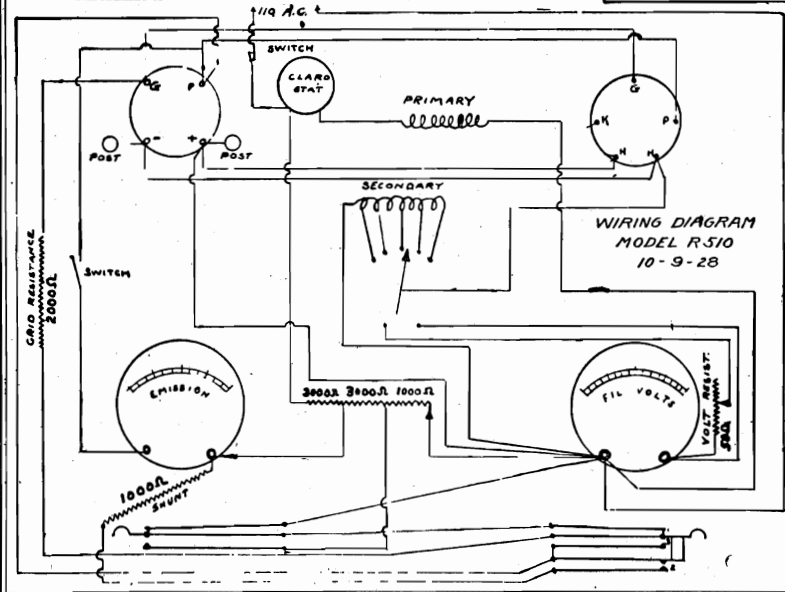
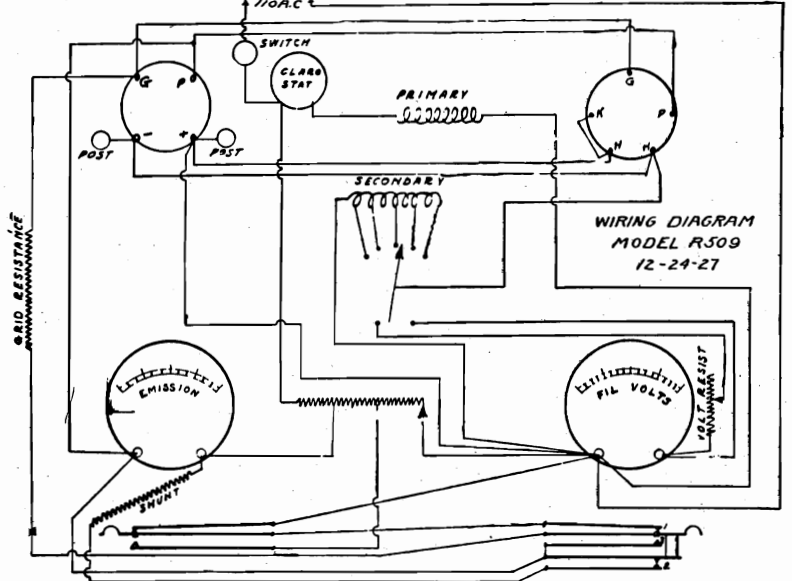
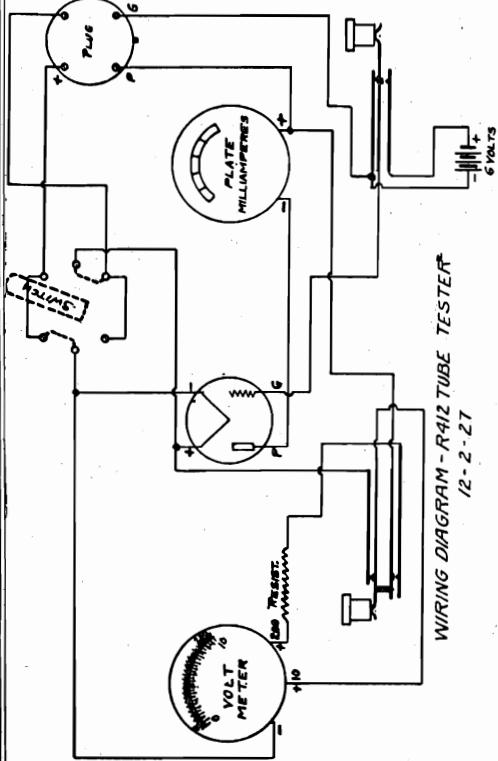
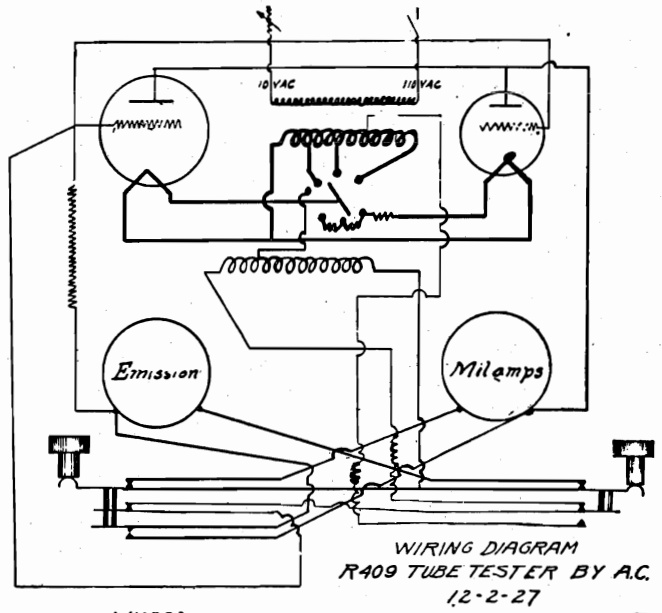
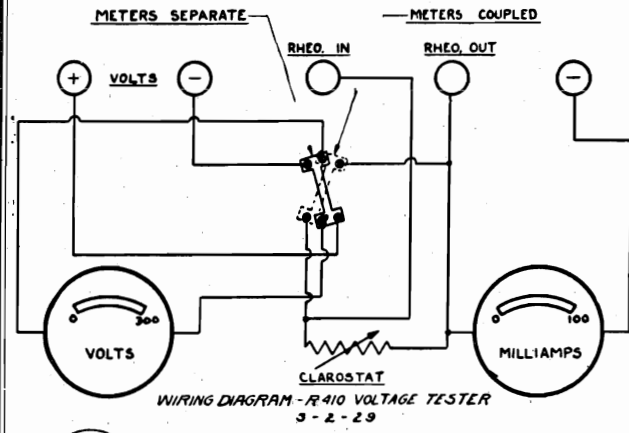

MODEL R-101,R-102
Service Notes

STEWART-WARNER CORP.

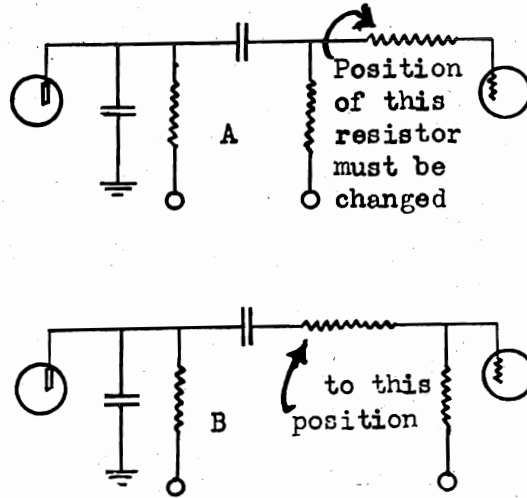
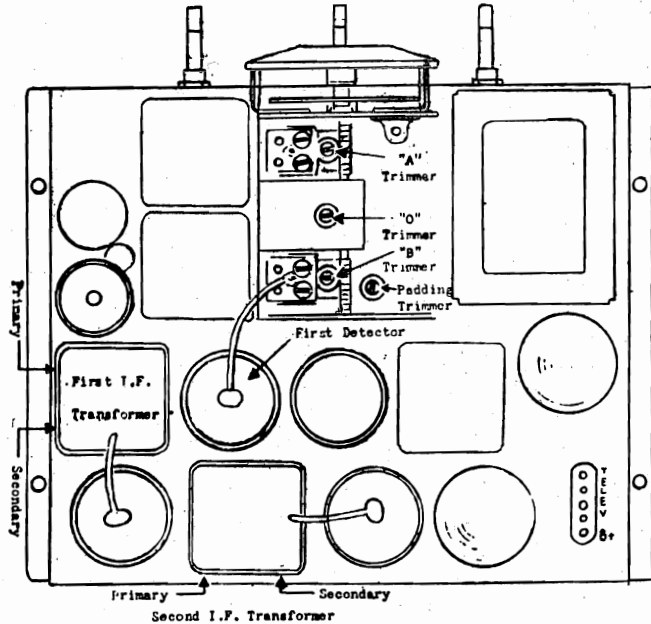

PENTODE SERVICE NOTES FOR MODELS R101-R102 series.

Pentode tubes in which the steady grid current is somewhat higher than average overload readily in the type of circuit used in the R101 and R102 series. Overloading of this type is evidenced in several ways;- by a distinct buzz in the speaker, by a peculiar fluttering reception that develops after the tube warms up and by short tube life. Troubles of this sort can be permanently eliminated by reducing the value of the resistance inserted in the pentode control grid circuit. Figure A shows the normal connection of the pentode control grid circuit in the above receivers. Shift the 500,000 ohm resistor from the normal position shown in figure A to that shown in figure B, namely between the blocking condenser and the junction of the grid leak and the control grid terminal of the pentode tube.

VOLUME DIFFICULTY IN R 102A.

If the output volume is below normal and the alignment is perfect, check the 2nd detector screen grid voltage and circuit. If it is appreciably below 20 volts when measured with a high resistance voltmeter, the 2 meg detector screen grid resistor is probably open circuited. Instead of replacing with a new unit, make the following changes, which as a matter of fact are now incorporated in the production models. The change consists of cutting out the 2 meg resistor and feeding the screen grid through the 500,000 ohm resistor that was previously used as the bleeder unit in this circuit. This change requires nothing more than the cutting of two wires and the soldering of two connections. This change will raise the screen grid voltage to about 30 volts. The diagrams below show the resistor terminal strip and the screen and plate circuits of the 2nd detector indicating the points at which the wires are cut and the new lead inserted. Cut wires at point marked "X" and make changes shown.

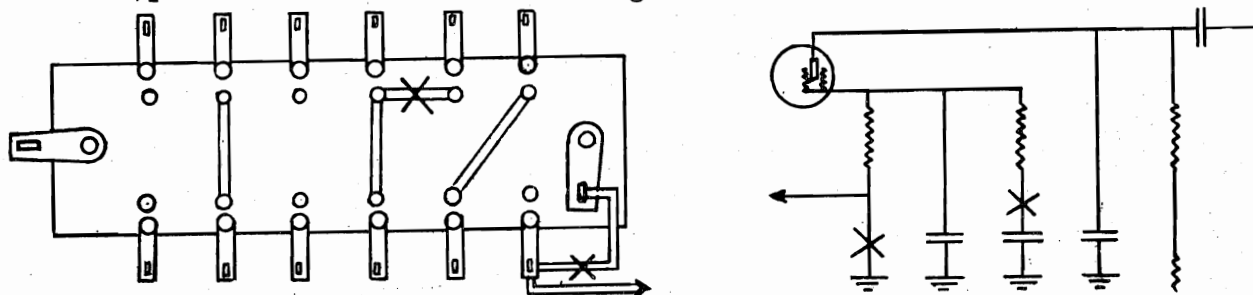

STEWART - WARNER CORP.

MODEL R-101, R-102
Service NotesADDITIONAL SERVICE NOTES FOR MODELS R101 and R102 Series

The following applies to oscillation troubles in the R102 series of receivers when the volume control is in an intermediate position. Tighten down all coil shields, then carefully realign the tuned circuits. This applies if the regeneration although excessive is not violently so. If the trouble is very pronounced, the aforementioned operations may not be of complete aid. In such cases the 2000 ohm suppressor resistor in the grid circuit of the oscillator tube should be cut out and shifted to the cathode circuit where it acts both as a suppressor and as a bias resistor. This resistor is the small red unit with the black end, that connects direct from the grid of the #27 oscillator tube to the oscillator coil. After disconnecting the resistor, resolder the open leads. Then remove the short bare wire from the cathode of the oscillator to the grounded lug on the padding trimmer condenser and connect the resistor between these two points.

Parasitic oscillation of the oscillator tube, evidenced by a continuous whistle, particularly upon the high frequency end of the dial is eliminated by the aforementioned change.

The phasing tool required to adjust the trimmers is part # T 70583 and is available at a cost of \$.25. To align the tuned circuits it is necessary to remove the chassis. Remove the control knobs and the four hex-head screws which hold the chassis in place. The speaker can be left in the cabinet since the leads are of sufficient length. The various trimmers are shown upon the chassis layout illustrated upon page 588-H. The IF transformers are of the tuned primary and tuned secondary type, each tuned by a separate trimmer. The IF trimmer adjusting screws can be reached thru small holes at the base of each shield, the primary in each case being at the left and the secondary at the right. If a commercial output meter is used it can be plugged into the television terminals, but a series condenser must be in one of the output meter leads. The test signal is fed into the 1st detector tube, the "A" lead of the oscillator being connected to the control grid, after the regular control lead has been removed. The IF peak frequency is 177.5 KC.

The RF and oscillator circuits require that the signal be fed to the receiver through the regular aerial and ground posts. Replace the control grid lead to the 1st detector. Ground the set and oscillator. Adjust the oscillator to 1400 KC. Tune the receiver to maximum output. Then reduce oscillator output until output meter reads half scale. Then tune "A" trimmer for maximum meter indication. If the output meter goes beyond full scale, REDUCE THE OSCILLATOR OUTPUT AND DO NOT CHANGE THE RECEIVER VOLUME CONTROL. Then adjust "B" and "O" trimmers for maximum output. The "O" trimmer adjustment is very critical. Then shift test receiver oscillator padding condenser for maximum output. Then adjust oscillator frequency to 600 KC and tune receiver for maximum output. Then increase test oscillator frequency to 1400 KC and carefully tune the set to this frequency. Then carefully adjust the "A", "B" and "O" trimmers for maximum output.

The following should be of interest in connection with the Models 203 and 204 speakers used in the present line of receivers. A high temperature developed by the field coil is not a sign of a defect. This is true even if the housing becomes too hot to touch, providing of course that the speaker is functioning in normal manner. This design is deliberate and proper provision has been made to safeguard against injury of the windings.

RADIO SERVICE NOTES (R-101 & 102)REPLACING POWER TRANSFORMERS

When replacing power transformers in Model 101 or 102 Radio Receivers, the following precautions must be observed, or the transformer is almost certain to hum badly.

After mounting the transformer but prior to clamping it tightly in place, paint the edges of the steel core of the transformer with a liberal quantity of shellac or medium thick clear lacquer to act as a binder and prevent the individual laminations from rattling. Allow the shellac to dry for several minutes and then using a heavy screw driver, tighten down the bolts with as much force as you can exert. A light screw driver will not enable you to tighten the bolts sufficiently. Do not omit the lock-washers under the screw-heads. Do not turn on the set until the binder has had a chance to dry, otherwise hum may not be eliminated.

When servicing a radio receiver in which the transformer hums, remove the two bolts holding it in position, thus loosening the transformer. It is not necessary to unsolder the leads. Drive in the fibre wedge which you will find on one side of the center leg of the core between the core and coil. This tightens the center portion of the core and prevents it from vibrating. Now paint the transformer core liberally with shellac, insulating varnish, or medium thick clear lacquer, and replace as directed above.

For humming filament transformers in Model 301 receivers, remove the two screws holding the transformer to the set and pry off the U shaped metal clamp from about the steel core, taking care that you do not bend it out of shape. Paint the edges, with particular attention to the top I section, with a liberal quantity of shellac or lacquer as in the case of power transformers and replace the U shaped clamp. If necessary, bend in the side flaps of the clamp so that they press the individual laminations together more firmly.

REPAIRING SHORT WAVE CONVERTERS HAVING POOR VOLUME

Occasionally a short wave converter may be found which is very insensitive even though all circuits check perfectly and the tubes are in good condition.

Converters of this type may frequently be made to operate satisfactorily by RESOLDERING EVERY SOLDERED CONNECTION IN THE CONVERTER, even though these connections may appear to be entirely satisfactory.

A poorly soldered connection may have sufficiently high resistance to materially affect performance on short waves, yet not high enough to show up on a simple continuity test.

MODEL 102-A, B & E
Schematic, Voltage
1st Type

STEWART-WARNER CORP.

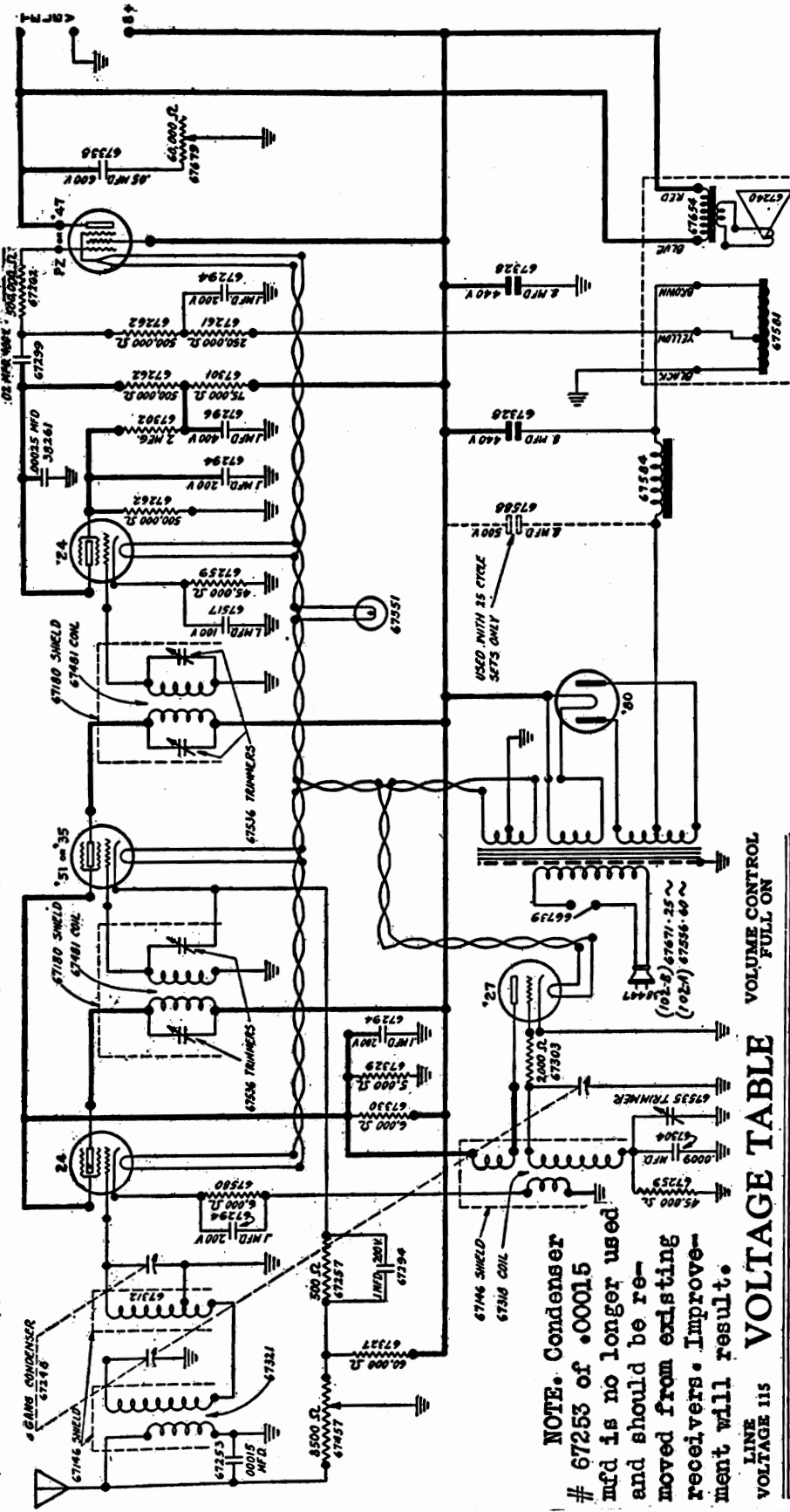

INTERMEDIATE FREQUENCY
TRANSFORMERS TUNED TO
177.5 K. C.

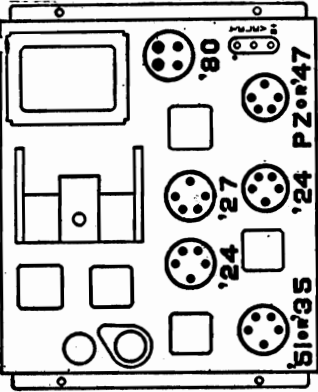

Voltage data accurate at sockets
Models 102A, B & E.

NOTE. Condenser # 67253 of .00015 mfd is no longer used and should be removed from existing receivers. Improvement will result.

LINE VOLTAGE 115 VOLTAGE TABLE VOLUME CONTROL FULL ON

Type of Tube	Tube Circuit	Filament Voltage	Plate Voltage	Screen Grid Voltage	Bias Voltage
'24	1st Det.	2.4	245	90	6.7
'27	Osc.	2.4	90	0	0
'51	I. F.	2.4	245	90	3
'24	2nd Det.	2.4	100	20	3
P. Z. or '47	Output	2.4	220	245	15*
'80	Rect.	4.8			

* This reading obtained between ground and yellow speaker lead. Direct reading from grid to ground or reading taken with a set tester will show low voltage because of high resistance in grid circuit.

STEWART - WARNER CORP.

MODEL R-102-A, B & E
Revised Schematic
Voltage.

Circuit Data of Stewart-Warner Models R-102-A, B & E.*

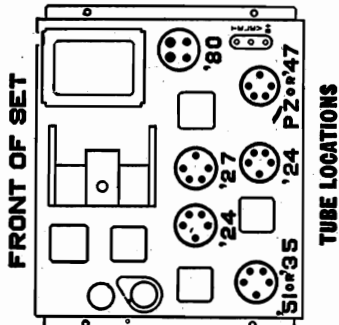
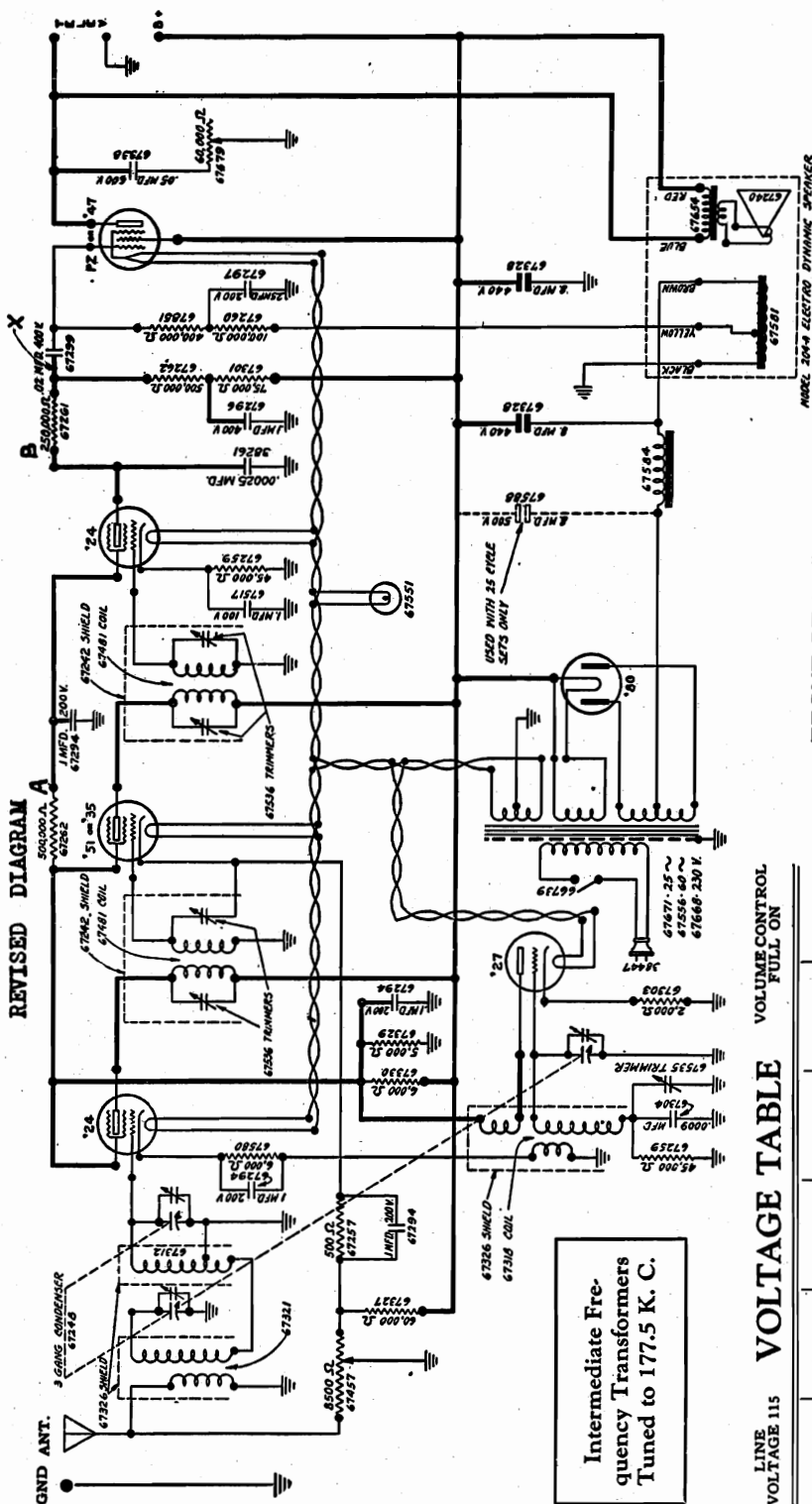

*This data sheet applies to the following serial numbers only:
Model 102-A, 34,000 upwards
Model 102-B, 10,500 upwards
Model 102-E, 10,200 upwards

LINE VOLTAGE 115 VOLTAGE TABLE VOLUME CONTROL FULL ON

Type of Tube	Tube Circuit	Filament Voltage	Plate Voltage	Screen Grid Voltage	Bias Voltage
'24	1st Det.	2.45	250	95	6.5
'27	Osc.	2.45	95		9
'51	I. F.	2.40	250	95	3
'24	2nd Det.	2.45	70	30	7
P. Z. or '47	Output	2.45	230	250	15 †
'80	Rect.	4.8	170		

All D. C. voltages measured with respect to ground, using high resistance voltmeter of 1000 ohms per volt. Readings will vary, depending upon voltage range of meter, being higher for higher range instruments. † This variation is most marked for second detector. ‡ This reading obtained between ground and yellow speaker lead. Direct reading from grid to ground or reading taken with a set tester will show about 3 volts because of high resistance in grid circuit.

CHANGES IN MODELS 102 A, B, E

- A. 500,000-ohm resistor changed to 1,000,000 ohms.
 - B. 250,000-ohm resistor omitted. 100,000-ohm resistor inserted at X
- When phonograph is used, a 6000-ohm resistor is shunted across the 45,000-ohm detector bias resistor. A radio-phonograph switch has been added to the volume control, connecting the pickup when volume of set is turned off.

MODEL 10-11
Resistance Data

STROMBERG - CARLSON TEL. MFG. CO.

'45 Control Grid 6,400 ohms Shunt Condenser
'45 Control Grid to Control Grid 11,400 ohms
'45 Control Grid to '45 Fil 6,650 ohms Halves of windings are not
'45 Plate to '45 Plate 406 ohms equally divided
'45 Plate to '80 Fil 350-700 ohms
'80 Fil to '80 P 15,185 ohms See Detector Plate
Output Transformer Secondary only 1.6ohms
RF and Detector Filament to Ground 0 resistance

Input winding only 4.6ohms
Secondary winding 4.6ohms
Broad Band Transformer Primary winding 1,960 ohms
Broad Band Transformer Secondary winding 81 ohms
2nd RF Plate Winding only 11 ohms
Secondary of second bi-resonant circuit 4.6ohms
3 RF Grid Winding only 4.6ohms
Input AF Transformer primary alone 11,090 ohms
Resistance across input AF transformer primary 250,000 ohms

All tubes out of socket and AC plug removed from power supply line.
Speaker plug removed from speaker socket. Phone switch in radio position

From Chassis To	Correct	Incorrect
Aerial	Condenser	
1 RF Control Grid to Input Tuning Condenser Stator	9.2 ohms	Coupling condenser
1 RF Control Grid	900-1100 ohms	Volume Control
1 RF Cathode	0 ohm	BC- 500 ohm unit-Y
1 RF Screen Grid	5,900 ohms	TC- 1 rf Cg-Y
1 RF Plate	11, 610 ohms	BC- 1 rf Sg-Y (.3 mfd)
		BC-1 rf Tr-Y (.3 mfd)
		BC- VD 80 P wdg
		BC- 2 rf P-Y (.3 mfd)
		BC- 3 rf P-Y (.3 mfd)
2 RF Control Grid	100,530 ohms	BC- 2 rf Cg wdg-Y
2 RF Cathode	0 ohm	See 1 RF Control Grid
2 RF Screen	6,500 ohms	BC- 2 rf Sg-Y (.3 mfd)
2 RF Screen to 3 RF Screen	0 ohm	BC- 1 rf Sg-Y (.3 mfd)
2 RF Plate	9,661 ohms	BC- 2 rf P wdg-P (.3 mfd)
2 RF Plate to 3 RF Plate	22 ohms	BC- 600 ohm unit-Y (.3mfd)
Detector Control Grid	5,100,000 ohms	See 1 RF Plate
Detector Cathode		TC-Y
Detector Screen Grid	20,000 ohms	Grid condenser
Detector Plate to '80 Fil	16,500 ohms	BLC- rf grid wdg-Y (.04mfd)
Detector Plate	51,078 ohms	BC- DK-Y (.6 mfd -1. mfd)
	64,653 ohms	BC-D Sg-Y (.3 mfd)
		BC- DP-Y (.0001 mfd)
		BC- AF Tr-Y (1 mfd)
		FC- '80 F -'80 P wdg
		BC- VD-Y
		FC- Filter chk-80 p wdg
3 RF Control Grid	942 ohms	BC-500 ohm unit-Y (3.mfd)
3 RF Cathode	0 ohms	TC- 3 rf Cg-Y
3 RF Screen Grid	6,500 ohms	See 2 RF Screen
3 RF Plate	9,661 ohms	See 2 RF Plate
		See 1 RF Plate

STROMBERG-CARLSON--Models 10 and 11
Line Voltage 120--Voltage Tap High

TUBE	TYPE	RESISTANCE	RESISTANCE		RESISTANCE		RESISTANCE		RESISTANCE	
			120V	100V	120V	100V	120V	100V	120V	100V
1	224	1.6k	2.4	1.35	2.5	2.5	80			
2	224	1.6k	2.4	1.35	2.5	2.5	80			
3	224	1.6k	2.4	1.35	2.5	2.5	80			
4	224	1.6k	2.4	1.35	2.5	2.5	80			
5	224	1.6k	2.4	1.35	2.5	2.5	80			
6	224	1.6k	2.4	1.35	2.5	2.5	80			
7	224	1.6k	2.4	1.35	2.5	2.5	80			
8	224	1.6k	2.4	1.35	2.5	2.5	80			
9	224	1.6k	2.4	1.35	2.5	2.5	80			
10	224	1.6k	2.4	1.35	2.5	2.5	80			

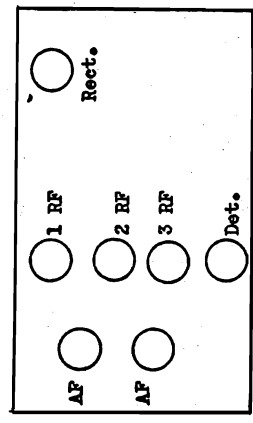

MODEL 19,20 AC
Voltage
Electrical Values

STROMBERG - CARLSON TEL. MFG CO.

INDUCTANCES

No.	Value
L1	.9 millihenry
L2	215. microhenry
L3	215. microhenry
L4	5.5 millihenry
L5	215. microhenry
L6	5.5 millihenry
L7	5.5 millihenry
L8	5.5 millihenry
L9	5.5 millihenry
L10	5.5 millihenry
L11	5.5 millihenry
L12	5.5 millihenry
L19	15. microhenry
L20	5.5 microhenry
L21	172. microhenry

RESISTANCES

No.	Value	Body	Tip	Dot
R1	500	Green	Blk	Brn
R2	600	Blue	Blk	Brn
R3	600	Blue	Blk	Brn
R4	3	(Wire wound)		
R5	10 megs	Brn	Blk	Blue
R6	100,000	Brn	Blk	Green
R7	750	(Wire wound)		
R8	10	(Wire wound)		
R9	500	Green	Blk	Brn
R10	6,500	Blue	Green	Red
R11	6,500	Blue	Green	Red
R12	60,000	Blue	Blk	Orange
R13	1,575	(Wire wound)		
R14	900	(Wire wound)		
R15	1,000	(Wire wound)		
R16	60	(Wire wound)		
R17	30,000	Orange	Blk	Orange
R18	400	(Wire wound)		
R19	100,000	Carbon potentiometer		

CONDENSERS

C2	.0004 mfd	max.
C3	.0004 mfd	max.
C4	.04 mfd	
C5	.000001 mfd	app.
C6	.3 mfd	
C7	.3 mfd	
C8	.0004 mfd	max.
C11	.3 mfd	
C12	.3 mfd	
C15	.3 mfd	
C16	.3 mfd	
C17	.00025 mfd	
C18	.001 mfd	
C20	.002 mfd	
C21	.6 mfd	
C22	.2 mfd	
C23	.04 mfd	
C24	.001 mfd	
C26	.0004 mfd	max.
C28	.3 mfd	
C29	.001 mfd	
C30	.01 mfd	
C31	.01 mfd	
C32	2. mfd	
C33	2. mfd	
C34	3. mfd	
C35	3. mfd	
C36	1. mfd	
C36	4. mfd	(25 cy.)
C37	1. mfd	
C38	1. mfd	

TABLE 4.
Normal Voltage Readings

(Be sure to make these readings with the Meter and Scale indicated, otherwise the results will not agree with those tabulated. Alternating voltages are indicated by italics.)

Voltage	Meter	Scale	Where Measured	Approx. Value in Volts
Heater Voltage Nos. 227 & 235 Tubes	A.C.	0-4	Across Heater Terminals of Sockets	2.4
Filament Voltage No. 245 Tubes	A.C.	0-4	Across Filament Terminals of Audio Output Sockets	2.4
Filament Voltage No. 280 Tube	A.C.	0-8	Across Filament Terminals of Rectifier Socket	4.8
Plate Voltage Radio Amplifiers	D.C.	0-250	Between Plate Terminal of R. F. Amplifier Socket (+) and Chassis Base (-)	180-170
Plate Voltage Mixer Tube	D.C.	0-250	Between Plate Terminal Mixer Tube Socket (+) and Chassis Base (-)	180-170
Plate Voltage Oscillator	D.C.	0-250	Between Plate Terminal of Oscillator Socket (+) and Chassis Base (-)	65-80
Plate Voltage I.F. Tubes	D.C.	0-250	Between Plate Terminals of I. F. Amplifier Sockets (+) and Chassis Base (-)	180-170
Plate Voltage Demodulator	D.C.	0-250	Between Plate Terminal of Demodulator Socket (+) and Chassis Base (-)	180-215
Plate Voltage Audio Output Tubes	D.C.	0-280	Between Plate Terminals Audio Output Socket (+) and 10 ohm Mid Tap Resistor R ₆ (-)	280
Control Grid Voltage R.F. Amplifier	D.C.	0-10	Between Control Grid Clip of R. F. Amplifier Tube (-) and Cathode (+) of R. F. Amplifier Tube	3
Control Grid Voltage Mixer Tube	D.C.	0-280	Between Control Grid Clip Mixer Tube (-) and Cathode (+) of Mixer Tube	10-15
Control Grid Voltage 1st I.F. Amplifier	D.C.	0-10	Between Control Grid Clip 1st I. F. Tube (-) to Cathode (+) of 1st I. F. Tube	3
Control Grid Voltage 2nd I.F. Tube	D.C.	0-10	Between Control Grid Clip 2nd I. F. Tube (-) to Cathode (+) of 2nd I. F. Tube	3
Grid Voltage Oscillator	D.C.	0-250	Across 6500 ohm Resistor R ₁₀	10-15
Grid Voltage Demodulator	D.C.	0-250	Across 30,000 ohm Resistor R ₁₇	20-25
Grid Voltage Audio Tubes	D.C.	0-250	Between Grids of Audio Tubes (-) to Mid Tap 10 ohm Resistor R ₆ (+)	45-50*
Screen Voltage Radio Amplifier Mixer 1st & 2nd I.F. Tubes	D.C.	0-250	Between Screen Terminals of Tubes (+) to Chassis Base (-)	80-90*
B Voltage R.F. Amplifier and Mixer Tube	D.C.	0-250	Between Tube Side of 600 ohm Resistor R ₂ and Chassis Base	150-170*
B Voltage 1st & 2nd I.F. and Mixer Tubes	D.C.	0-250	Between "High" Side of Voltage Divider and Chassis Base	180-170*
B Voltage Audio Tubes	D.C.	0-250	Between Mid Tap of Audio Output Transformer (+) and Chassis Base L-	300
C Voltage Audio Output Tubes	D.C.	0-250	Across 750 ohm Biasing Resistor R ₈	30
Speaker Field Voltage	D.C.	0-250	Across Small Pins of Speaker Connector Socket	180-170
Plate Voltage A.C. Pere Anode No. 280 Rectifier	A.C.	See Remarks	Between P Terminals No. 280 Rectifier Socket and Chassis Base	225-280*

*These voltage vary with dial setting and position of volume control.
Cannot be measured on Weston Model 528 Meter unless multiplier is used.

MODEL 19,20 AC
Resistance Data

STROMBERG - CARLSON TEL. MFG. CO.

All tubes removed from sockets and AC plug disconnected from power supply.
Speaker plug removed from speaker socket. Volume control maximum unless
otherwise stated. See Notes.

From Chassis To	Correct	Incorrect
RF Control Grid	504.9 ohms	BC- rf Cg wdg-Y
RF Cathode (V.C.Max)	60 ohms	BC- if K-Y (.3 mfd)
RF Cathode (V.C.Min)	1,060 ohms	
RF Screen Grid	2,560 ohms	BC- rf Sg-Y (.3 mfd)
		BC- if Sg-Y (.3 mfd)
RF Plate	4,179 ohms	BC- rf P-Y (.3 mfd)
		BC- if P wdg-Y (.3 mfd)
		FC- if P wdg-Y (1. mfd)
Mixer Tube Control Grid	4.9 ohms	TC- Mixer Cg-Y
Mixer Cathode	6,560 ohms	BC-Osc Coupling Coil-Y
		See RF Cathode
Mixer Screen Grid	2,560 ohms	See RF Screen
Mixer Plate	4,179 ohms	See RF Plate
		TC- if Tr Primary
Mixer Plate to RF Plate	88 ohms	
1 IF Control Grid	42.3 ohms	TC- 1 if Cg-Y
1 IF Cathode	60 ohms	See RF Cathode
1 IF Screen Grid	1,960 ohms	See RF Screen
1 IF Plate	3,579 ohms	BC- 1 if P wdg-Y
		See Mixer Plate
1 IF Plate to 2 IF Plate	90.5 ohms	
2 IF Control Grid	45.3 ohms	TC- 2 if Cg-Y
2 IF Cathode	60 ohms	BC- 2 if K-Y (.3 mfd)
2 IF Screen	1,960 ohms	See RF Screen
2 IF Plate	3,580 ohms	See 1 IF Plate
Demodulator Control Grid	10,100,000 ohms	TC- grid condenser-Y
		BC- grid wdg-Y (.001 mfd)
Demodulator Cathode	30,000 ohms	BC- Dem K-Y (2 mfd)
Demodulator Plate to 80 Fil	51,040 ohms	
Demodulator Plate to Chassis	0 ohm	BC- AF Tr wdg-Y (2 mfd)
		FC- Filter ohk-Y (3 mfd)
		BC- AF Tr wdg- Dem K
		BC- Dem P- Dem K-
'45 Control Grid	4,340-5,350 ohms	Split windings do not have equal resistance
'45 Control Grid to '45 Fil	5,100-6,000 ohms	
'45 Plate to Plate	425 ohms	Tone Control condenser
'45 Plate to 80 Fil	500-525 ohms	
Output Transformer secondary only	1.4 ohms	
Oscillator Control Grid	502 ohms	Oscillator winding is tapped
Oscillator Cathode	6,500 ohms	BC- Osc X-Y (.001 mfd)
Oscillator Plate to RF Screen	1.2 ohms	
RF Mixer- IF and Demodulator Filament to chassis	0 ohm	
Across AC plug (LO)	4.1 ohms	
Across AC plug (HI)	4.5 ohms	
AC plug to chassis	0 ohm	FC- across primary

MODEL 22,22-A
Chassis Wiring

STROMBERG-CARLSON TEL. MFG. CO.

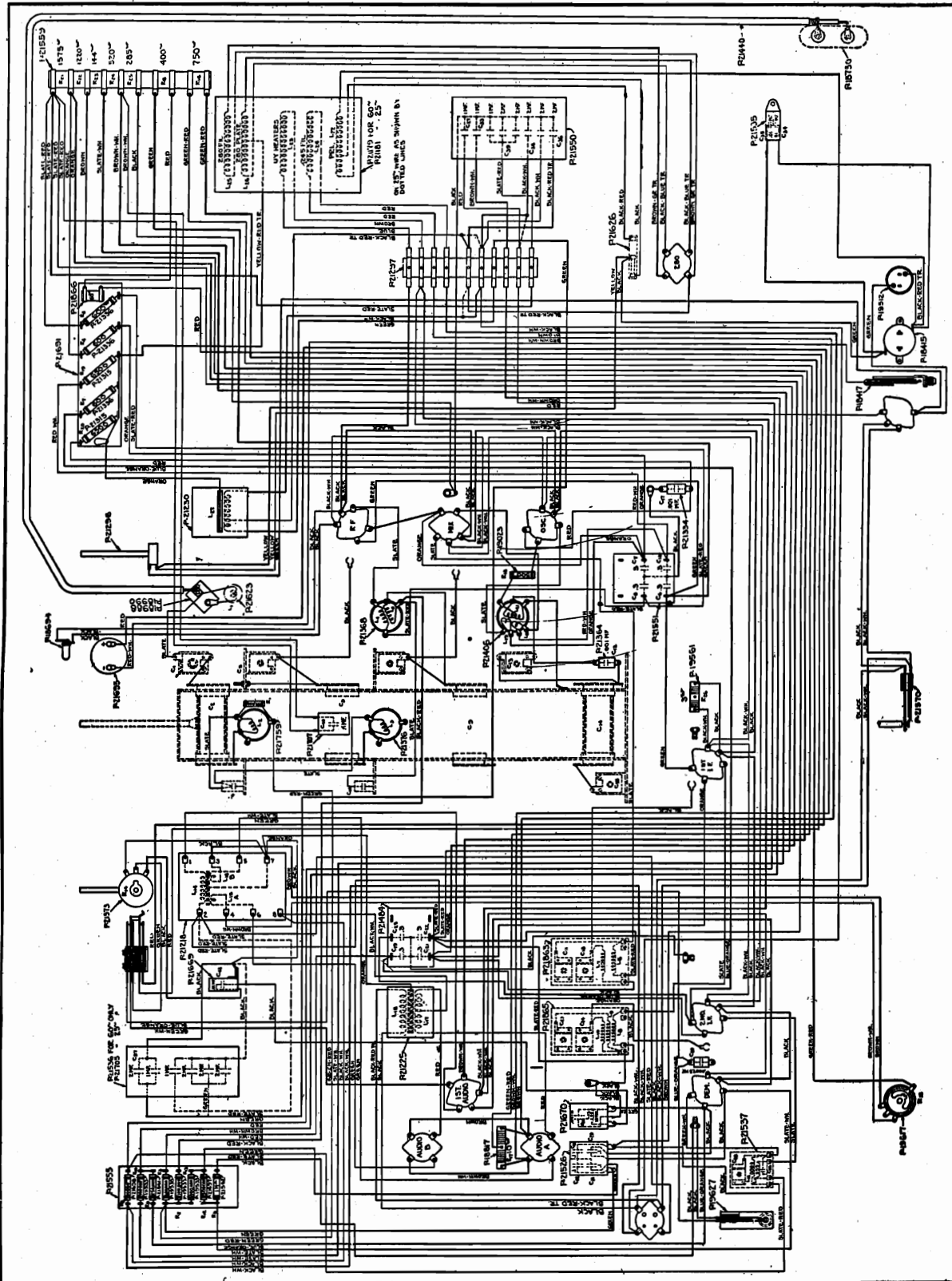

STROMBERG - CARLSON TEL. MFG. CO.

MODEL 22,22-A
Schematic

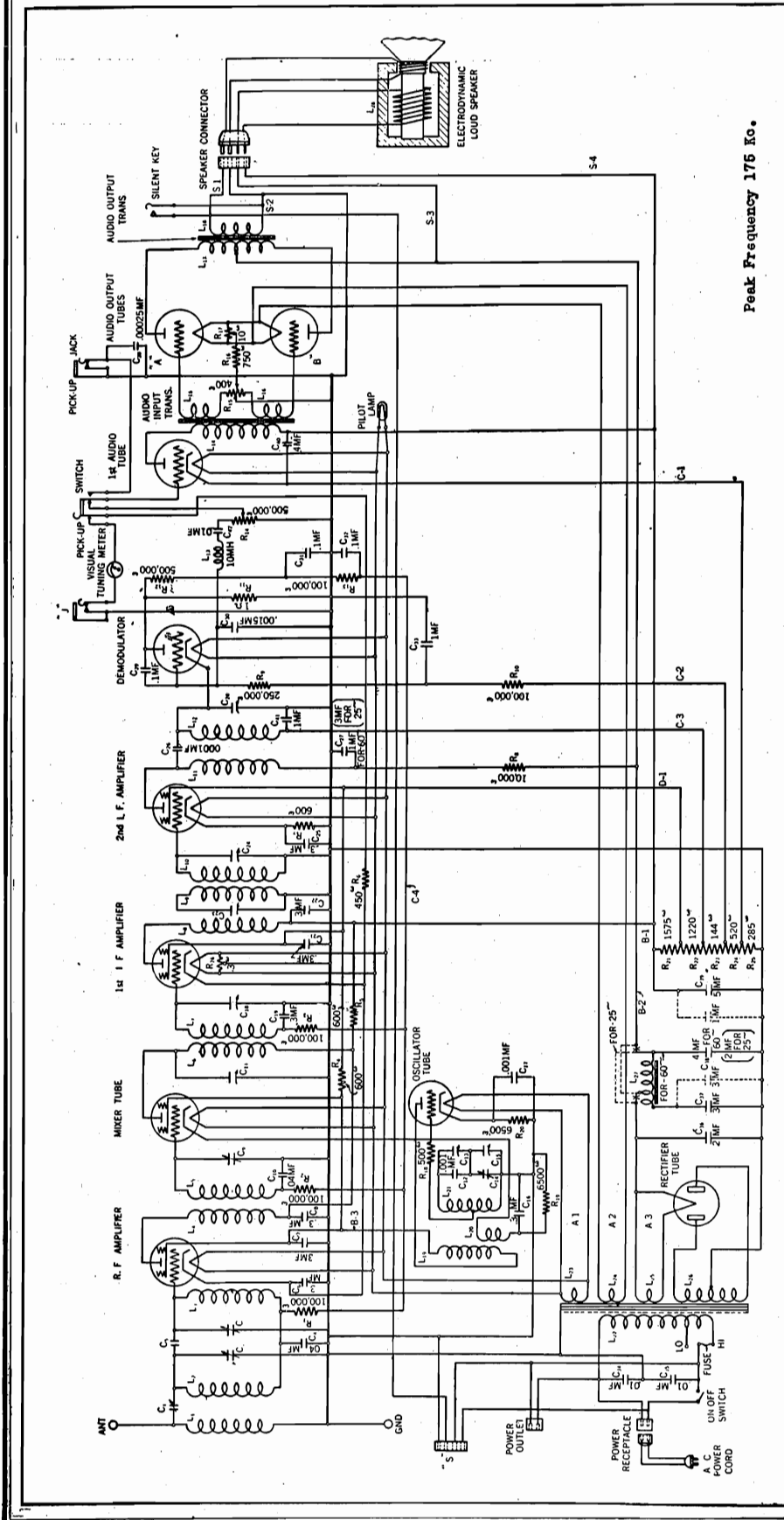

Peak Frequency 175 Kc.

The 1st and 2nd IF transformers have two tuning adjustments. The 3rd, has but one tuning adjustment. Three windings are used in the 2nd IF transformer. The tuning condensers are accessible through holes through the top of the IF transformer containers.

Model 22 (1931)

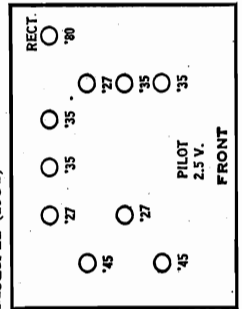

MODEL 22,22-A

Voltage
Electrical Values

STROMBERG - CARLSON TEL. MFG. CO.

TUBE	APPROX. VOLTS	CONDENSERS	RESISTANCES
Plate Voltage RF	135-155	C2 400. mmf max	No. Value
Plate Voltage 1st Det.	135-155	C3 400. mmf max	R1 100,000 Brown Black Yellow
Plate Voltage Osc.	75-90	C4 .04 mf	R2 100,000 Brown Black Yellow
Plate Voltage 1st I.F.	135-155	C5 Approx. 1 mmf	R3 100,000 Brown Black Yellow
Plate Voltage 2nd I.F.	220-245	C6 .3 mf	R4 600 Blue Black Brown
Plate Voltage 2nd Det.	Note A	C7 .3 mf	R5 600 Blue Black Brown
Plate Voltage 1st AF	135-155	C8 .3 mf	R6 450 (Wire Wound)
Plate Voltage AF Output	230-260	C9 400. mmf max.	R7 600 Blue Black Brown
"C" Voltage RF	4.0	C10 .04 mf	R8 10,000 Brown Black Orange
"C" Voltage 1st Det.	9.4	C12 .001 mf	R9 250,000 Red Green Yellow
"C" Voltage 1st IF	4.1	C14 400. mmf max.	R10 100,000 Brown Black Yellow
"C" Voltage 2nd IF	2.8	C16 .3 mf	R11 1 meg Brown Black Green
Grid Voltage Osc.	18.5-21.0	C17 .001 mf	R12 500,000 Green Black Yellow
Grid Voltage 2nd Osc.	35-40	C19 .3 mf	R13 100,000 Brown Black Yellow
Grid Voltage 1st AF	11.6	C20 250. mmf	R14 500,000
Grid Voltages AF	45-55*	C21 .3 mf	R15 400 (Wire Wound)
Screen Voltage RF	75-90*	C22 .3 mf	R16 750 (Wire Wound)
Screen Voltage 1st Det	75-90*	C25 .3 mf	R17 10 (Wire Wound)
Screen Voltage IF Tubes	75-90*	C25 .3 mf	R18 500 Green Black Brown
B Voltage RF 1st Det	135-155*	C26 100. mmf	R19 6,500 Blue Green Red
B Voltage 1st IF	135-155*	C27 1. mf	R20 6,500 Blue Green Red
B Voltage 2nd IF	225-250*	C29 (3 mf for 25 cyc)	R21 1,575 (Wire Wound)
B Voltage 1st AF	135-155	C30 .1 mf	R22 1,220 (Wire Wound)
B Voltage Output (AF)	285-330	C31 .0015 mf	R23 144 (Wire Wound)
C Voltage 1st AF	11.5	C32 .1 mf	R24 520 (Wire Wound)
C Voltage AF Output	45-55	C33 .1 mf	R25 285 (Wire Wound)
Speaker Field Voltage	135-155	C34 1. mf	R26 3 (Wire Wound)
AC Plate Voltage		C35 .01 mf	
per Anode	325-355	C36 .01 mf	
Heater Voltage '27-35	2.4	C37 2. mf	
Filament Voltage '45	2.4	C38 (6 mf for 25 cyc)	
Filament Voltage '80	4.8	C39 (2 mf for 25 cyc)	
*These voltages vary with Dial setting and position of Volume Control.		C40 (6 mf for 25 cyc)	
NOTE "A" No voltage can be obtained across these terminals. The plate is grounded to the Chassis through 1 Megohm R-11.		C41 .4 mf	
		C42 .01 mf	
			INDUCTANCES
			L1 .9 Millihenry
			L2 215. Microhenry
			L3 215. Microhenry
			L4 5.5 Millihenry
			L5 215. Microhenry
			L6 5.5 Millihenry
			L7 5.5 Millihenry
			L8 5.5 Millihenry
			L9 5.5 Millihenry
			L10 5.5 Millihenry
			L11 40. Millihenry
			L12 5.5 Millihenry
			L13 10. Millihenry
			L19 15. Microhenry
			L20 5.5 Microhenry
			L21 172. Microhenry

STROMBERG - CARLSON TEL. MFG. CO.

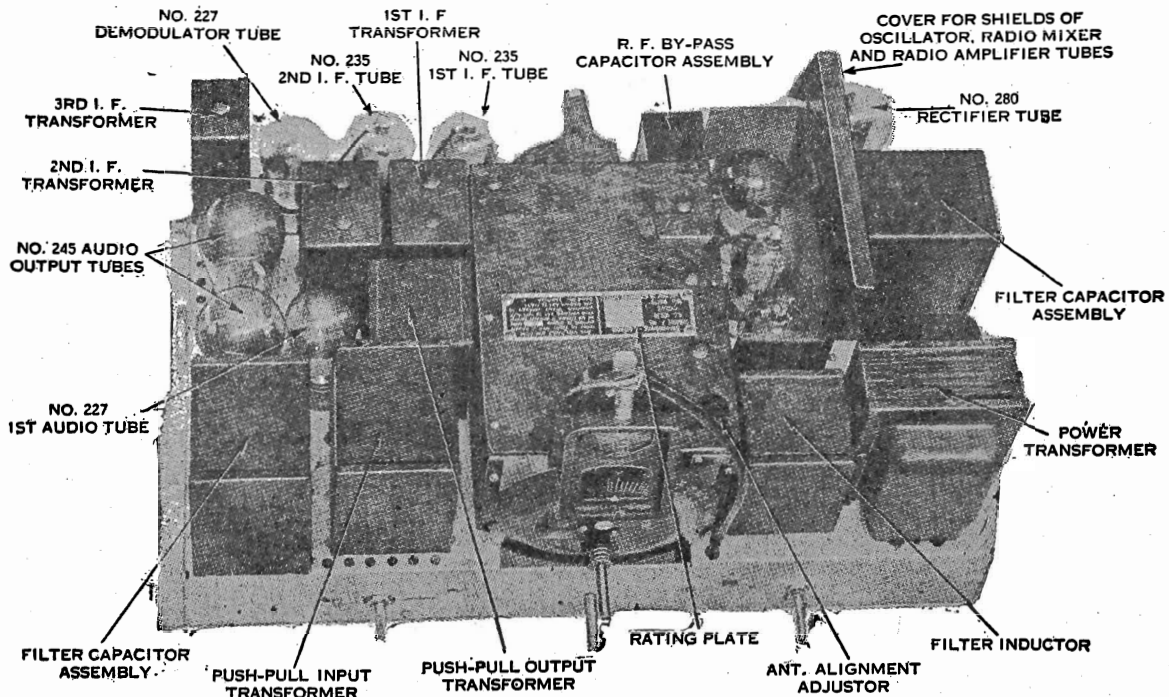
MODEL 22,22-A
Chassis Views

Top View of Chassis with Tube Shields Removed.

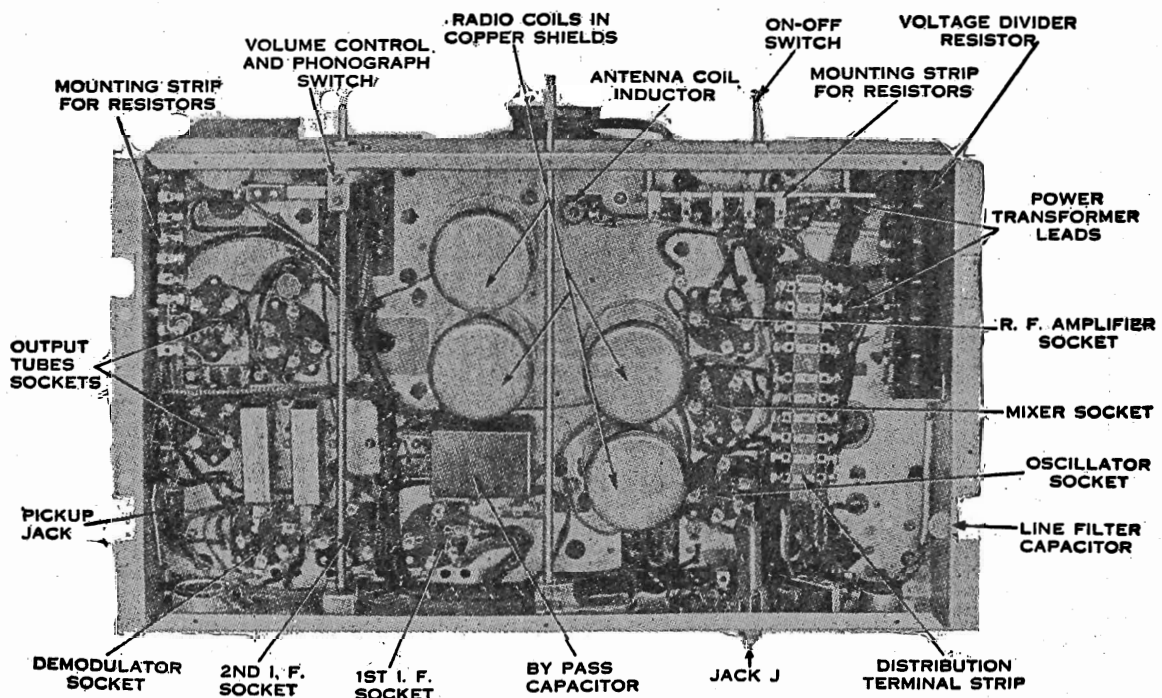

Bottom View of Chassis (Bottom Shield Removed).

The hum adjuster is located at the rear of the chassis under the third IF transformer. The fuse box is to the front of the rectifier tube socket looking at the chassis from the front. The two outlets near the rectifier tube socket are the power input and power output. The pickup jack is to the rear of the audio output tubes, next to the speaker connector receptacle.

MODEL 25,26 AC
Chassis Wiring

STROMBERG - CARLSON TEL. MFG. CO.

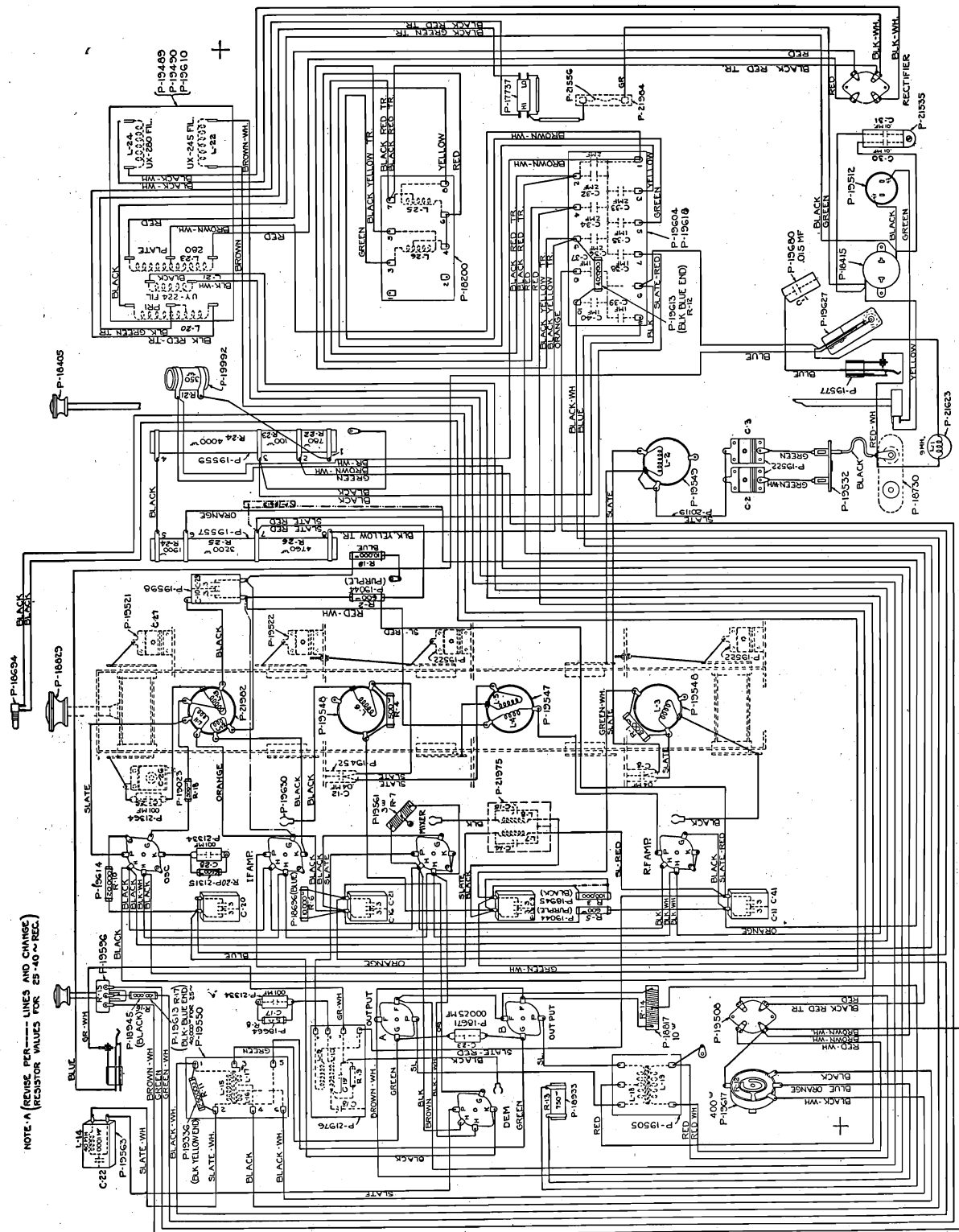

NOTE A (REVISE PER... LINES AND CHANGE RESISTOR VALUES FOR 25-40 REC.)

Models 25, 26 (1931)

STROMBERG - CARLSON TEL. MFG. CO.

MODEL 25,26 AC Schematic

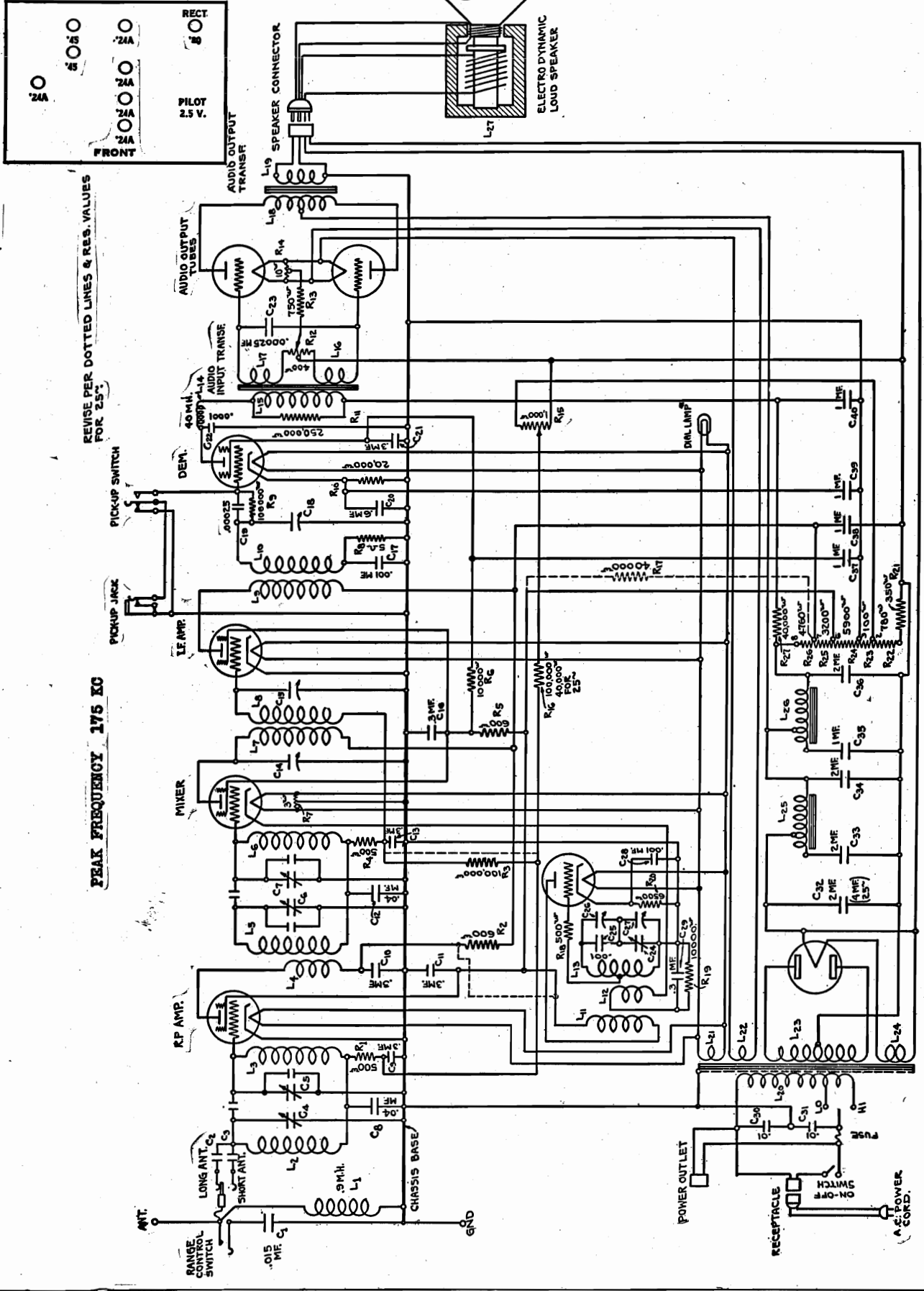

MODEL 25,26 AC
Voltage

STROMBERG-CARLSON TEL. MFG. CO.

NOS. 25 AND 26 RECEIVERS

TABLE III. CAPACITOR IDENTIFICATION—Continued

Designation	Function	Value	Voltage	Meter	Scale	Where Measured	Approx. Value in Volts
C ₁	Capacitor across Grids of Push-Pull (Output) Tubes	250 Mmf.	Plate Voltages	D. C.	0-250	Between Plate Terminals of Audio Output Sockets (+) and Mid Tap 10 ohm Resistor (-)	225-255
C ₂	Unit of Variable Gang Capacitor	400 Mmf. Max.	Audio Output Tubes	D. C.	0-10	Between Center Terminal of 1000 ohm Volume Control Potentiometer (-) and Chassis Base (+)	2.5
C ₃	Series Capacitor for Oscillator Tuning Circuit	.01 Mf.	Control Grid Voltage, R. F., Mixer and I. F. Tubes	D. C.	0-250	Between Cathode Terminal of Oscillator Socket (+) and Chassis Base (-)	13
C ₄	Aligning Capacitor for C ₃	.01 Mf.	Grid Voltage Oscillator Tube	D. C.	0-250	Between Cathode Terminal of Demodulator Socket (+) and Chassis Base (-)	7
C ₅	Aligning Capacitor for C ₃	.01 Mf.	Control Grid Voltage Demodulator Tube	D. C.	0-250	Between Grid Terminals of Audio Output Sockets (-) and Mid Tap 10 ohm Resistor (+)	40-50
C ₆	Cathode By-pass of Oscillator	2 Mf.	Screen Voltages	D. C.	0-250	Between Screen Terminals of Tubes (+) and Chassis Base (-)	130-150
C ₇	Cathode By-pass of Mixer Tube	(4 Mf. 25 Cycles)	R. F., Mixer, I. F. and Demodulator Tubes	D. C.	0-250	Between Tube Side of 600 ohm Resistor (+) and Chassis Base (-)	135-150
C ₈	Power Line Filter Capacitor	2 Mf.	B Voltage R. F. Amplifier Tube	D. C.	0-250	Between Terminal No. 6 on Voltage Divider (+) and Chassis Base (-)	135-150
C ₉	Ripple Filter Capacitor	2 Mf.	B Voltages Mixer and I. F. Tubes	D. C.	0-250	Between Terminal No. 1 on Input Transformer (+) and Chassis Base (-)	200-230
C ₁₀	Ripple Filter Capacitor	1 Mf.	B Voltage Demodulator Tube	D. C.	0-250	Between Mid Tap on Audio Output Transformer (+) and Chassis Base (-)	250-280
C ₁₁	Ripple Filter Capacitor	2 Mf.	B Voltage Audio Output Tubes	D. C.	0-10	Across 100 ohm Resistance on Voltage Divider	2.5
C ₁₂	Demodulator Screen Circuit Filter Capacitor	1 Mf.	C Voltage R. F., Mixer and I. F. Tubes	D. C.	0-250	Across 6,500 ohm Biasing Resistor	12
C ₁₃	R. F. Amplifier and Mixer Plate Circuit Filter Capacitor	1 Mf.	C Voltage Demodulator Tube	D. C.	0-250	Across 20,000 ohm Biasing Resistor	7
C ₁₄	Cathode By-pass of Demodulator	1 Mf.	Output Tube	D. C.	0-250	Across 750 ohm Biasing Resistor	40-50
C ₁₅	Demodulator Plate Circuit Filter Capacitor	1 Mf.	Total B Voltage	D. C.	0-500	Between Terminals No. 1 and No. 8 on Voltage Divider	260-300

III. NORMAL VOLTAGE READINGS

Voltage	Meter	Scale	Where Measured	Approx. Value in Volts
Heater Voltages No. 224 and 227 Tubes	A. C.	0-1	Across Heater Terminals of Sockets	2.5
Heater Voltages No. 245 Tubes	A. C.	0-1	Across Heater Terminals of Audio Output Sockets	2.5
Heater Voltage No. 280 Tube	A. C.	0-3	Across Heater Terminals of Rectifier Socket	4.5
Plate Voltage R. F. Amplifier Tube	D. C.	0-250	Between Plate Terminal of R. F. Amplifier Socket (+) and Chassis Base (-)	135-150
Plate Voltage Mixer Tube	D. C.	0-250	Between Plate Terminal of Mixer Socket (+) and Chassis Base (-)	135-150
Plate Voltage I. F. Tube	D. C.	0-250	Between Plate Terminal of I. F. Socket (+) and Chassis Base (-)	135-150
Plate Voltage Oscillator Tube	D. C.	0-250	Between Plate Terminal of Oscillator Socket (+) and Chassis Base (-)	80-90
Plate Voltage Demodulator Tube	D. C.	0-250	Between Plate Terminal of Demodulator Socket (+) and Chassis Base (-)	190-215

NORMAL VOLTAGE READINGS—Continued

Meter	Scale	Where Measured	Approx. Value in Volts
D. C.	0-250	Between Plate Terminals of Audio Output Sockets (+) and Mid Tap 10 ohm Resistor (-)	225-255
D. C.	0-10	Between Center Terminal of 1000 ohm Volume Control Potentiometer (-) and Chassis Base (+)	2.5
D. C.	0-250	Between Cathode Terminal of Oscillator Socket (+) and Chassis Base (-)	13
D. C.	0-250	Between Cathode Terminal of Demodulator Socket (+) and Chassis Base (-)	7
D. C.	0-250	Between Grid Terminals of Audio Output Sockets (-) and Mid Tap 10 ohm Resistor (+)	40-50
D. C.	0-250	Between Screen Terminals of Tubes (+) and Chassis Base (-)	130-150
D. C.	0-250	Between Tube Side of 600 ohm Resistor (+) and Chassis Base (-)	135-150
D. C.	0-250	Between Terminal No. 6 on Voltage Divider (+) and Chassis Base (-)	135-150
D. C.	0-250	Between Terminal No. 1 on Input Transformer (+) and Chassis Base (-)	200-230
D. C.	0-250	Between Mid Tap on Audio Output Transformer (+) and Chassis Base (-)	250-280
D. C.	0-10	Across 100 ohm Resistance on Voltage Divider	2.5
D. C.	0-250	Across 6,500 ohm Biasing Resistor	12
D. C.	0-250	Across 20,000 ohm Biasing Resistor	7
D. C.	0-250	Across 750 ohm Biasing Resistor	40-50
D. C.	0-500	Between Terminals No. 1 and No. 8 on Voltage Divider	260-300
D. C.	0-500	Across Small Pins of Speaker Connector Socket	300-335
A. C.		Between P Terminals of No. 280 Rectifier Socket and Negative Side of 350 ohm Resistor	320-350*

NOTE: Measurements to be taken on 0-250 Volt Scale to give accurate readings as this voltage is across only 20,000 ohms.
* Cannot be measured on Weston, Model 628 Meter unless multiplier is used.

STROMBERG - CARLSON TEL. MFG. CO.

MODEL 25,26 AC
Condenser-Resistor
Values

NOS. 25 AND 26 RECEIVERS

II. COMPONENT IDENTIFICATION TABLES

TABLE I. INDUCTOR IDENTIFICATION

Designation	Function	Value
L ₁	Antenna Inductor	.9 Millihenry
L ₂	First Coil Preslector Bi-resonator	195 Microhenrys
L ₃	Second Coil Preslector Bi-resonator	195 Microhenrys
L ₄	Primary of Radio Transformer	
L ₅	First Coil of Second Bi-resonator	195 Microhenrys
L ₆	Second Coil of Second Bi-resonator	195 Microhenrys
L ₇	Primary of First I. F. Transformer	10 Millihenrys
L ₈	Secondary of First I. F. Transformer	10 Millihenrys
L ₉	Primary of Second I. F. Transformer	10 Millihenrys
L ₁₀	Secondary of Second I. F. Transformer	10 Millihenrys
L ₁₁	Plate Inductor of Oscillator	15 Microhenrys
L ₁₂	Cathode Coupling Inductor of Mixer Tube	3.5 Microhenrys
L ₁₃	Grid Inductor of Oscillator	158 Microhenrys
L ₁₄	Demodulator Plate Radio Frequency Choke	40 Millihenrys
L ₁₅	Primary of Push-Pull Input Transformer	
L ₁₆	Secondary of Push-Pull Input Transformer	
L ₁₇	Primary of Push-Pull Output Transformer	
L ₁₈	Secondary of Push-Pull Output Transformer	
L ₁₉	Primary of Power Transformer	
L ₂₀	Secondary of Power Transformer for Heaters	
L ₂₁	Secondary of Power Transformer for Output Tube Filaments	
L ₂₂	Secondary of Power Transformer for Plates of Rectifier Tube	
L ₂₃	Secondary of Power Transformer for Rectifier Filament	
L ₂₄	First Ripple Filter Inductor	
L ₂₅	Second Ripple Filter Inductor	
L ₂₆	Speaker Field Winding	

TABLE II. RESISTOR IDENTIFICATION

Designation	Function	Value
R ₁	Grid Bias Feeder of Radio Amplifier	500 Ohms
R ₂	Filter Resistor Plate Circuit of Radio Amplifier	600 Ohms
R ₃	Grid Bias Feeder for Mixer of I. F. Amplifier	100,000 Ohms
R ₄	Grid Bias Feeder for Mixer Tube	500 Ohms
R ₅	Filter Resistor for Screen Circuits of Mixer and I. F. Amplifier	600 Ohms
R ₆	Filter Resistor for Demodulator Screen Circuit	10,000 Ohms
R ₇	Mid-tap Resistor Heater Circuit (at Mixer Tube)	3 Ohms
R ₈	Grid Bias Feeder for Demodulator	5 Megohms
R ₉	Grid Bias Feeder for Demodulator	100,000 Ohms
R ₁₀	Cathode Resistor of Demodulator Tube	20,000 Ohms

TABLE II. RESISTOR IDENTIFICATION—Continued

Designation	Function	Value
R ₁₁	Shunt Resistor for Primary of Push-Pull Input Transformer	250,000 Ohms
R ₁₂	Hum Balancer Potentiometer	400 Ohms
R ₁₃	Grid Biasing Resistor at Power Output Tube	750 Ohms
R ₁₄	Mid-Tap Resistor of Filament Circuit of Output Tube	10 Ohms
R ₁₅	Volume Control Potentiometer	1,000 Ohms
R ₁₆	Filter Resistor for Grid Bias Circuits	100,000 Ohms (40,000 Ohms 25 Cycles)
R ₁₇	Filter Resistor of Screen Circuits, 25 Cycles Only	40,000 Ohms
R ₁₈	Series Grid Resistor of Oscillator	500 Ohms
R ₁₉	Cathode Resistor of Mixer Tube	10,000 Ohms
R ₂₀	Cathode Resistor of Oscillator Tube	6,500 Ohms
R ₂₁	Auxiliary Voltage Divider Resistor	350 Ohms
R ₂₂	Section of Voltage Divider Resistor	780 Ohms
R ₂₃	Section of Voltage Divider Resistor	100 Ohms
R ₂₄	Section of Voltage Divider Resistor	5,900 Ohms
R ₂₅	Section of Voltage Divider Resistor	3,200 Ohms
R ₂₆	Section of Voltage Divider Resistor	4,760 Ohms
R ₂₇	Filter Resistor of Demodulator Plate Circuit	40,000 Ohms

TABLE III. CAPACITOR IDENTIFICATION

Designation	Function	Value
C ₁	Range Control Capacitor	.015 Mf.
C ₂	"Long Antenna" Aligning Capacitor	
C ₃	"Short Antenna" Aligning Capacitor	
C ₄	Unit of Variable Gang Capacitor	400 Mmf. Max.
C ₅	Unit of Variable Gang Capacitor	400 Mmf. Max.
C ₆	Unit of Variable Gang Capacitor	400 Mmf. Max.
C ₇	Unit of Variable Gang Capacitor	.04 Mf.
C ₈	First Bi-resonator Main Coupling Capacitor	.3 Mf.
C ₉	Grid Circuit By-pass of Radio Amplifier	.3 Mf.
C ₁₀	Plate Circuit By-pass of Radio Amplifier	.3 Mf.
C ₁₁	Screen Circuit By-pass of Radio Amplifier	.04 Mf.
C ₁₂	Second Bi-resonator Main Coupling Capacitor	.3 Mf.
C ₁₃	Grid Circuit By-pass of Mixer and I. F. Amplifier	.001 Mf.
C ₁₄	Aligning Capacitor for Primary of First I. F. Transformer	
C ₁₅	Aligning Capacitor for Secondary of First I. F. Transformer	
C ₁₆	Screen Circuits By-pass for Mixer and I. F. Amplifier	
C ₁₇	Grid Circuit By-pass of Demodulator	
C ₁₈	Aligning Capacitor for Secondary of Second I. F. Transformer	
C ₁₉	"Grid Capacitor" of Demodulator	250 Mmf.
C ₂₀	Cathode By-pass of Demodulator	6 Mf.
C ₂₁	Screen Circuit By-pass of Demodulator	3 Mf.
C ₂₂	Demodulator Plate Filter Capacitor	100 Mmf.

MODEL 27 AC
Chassis Wiring

STROMBERG - CARLSON TEL. MFG. CO.

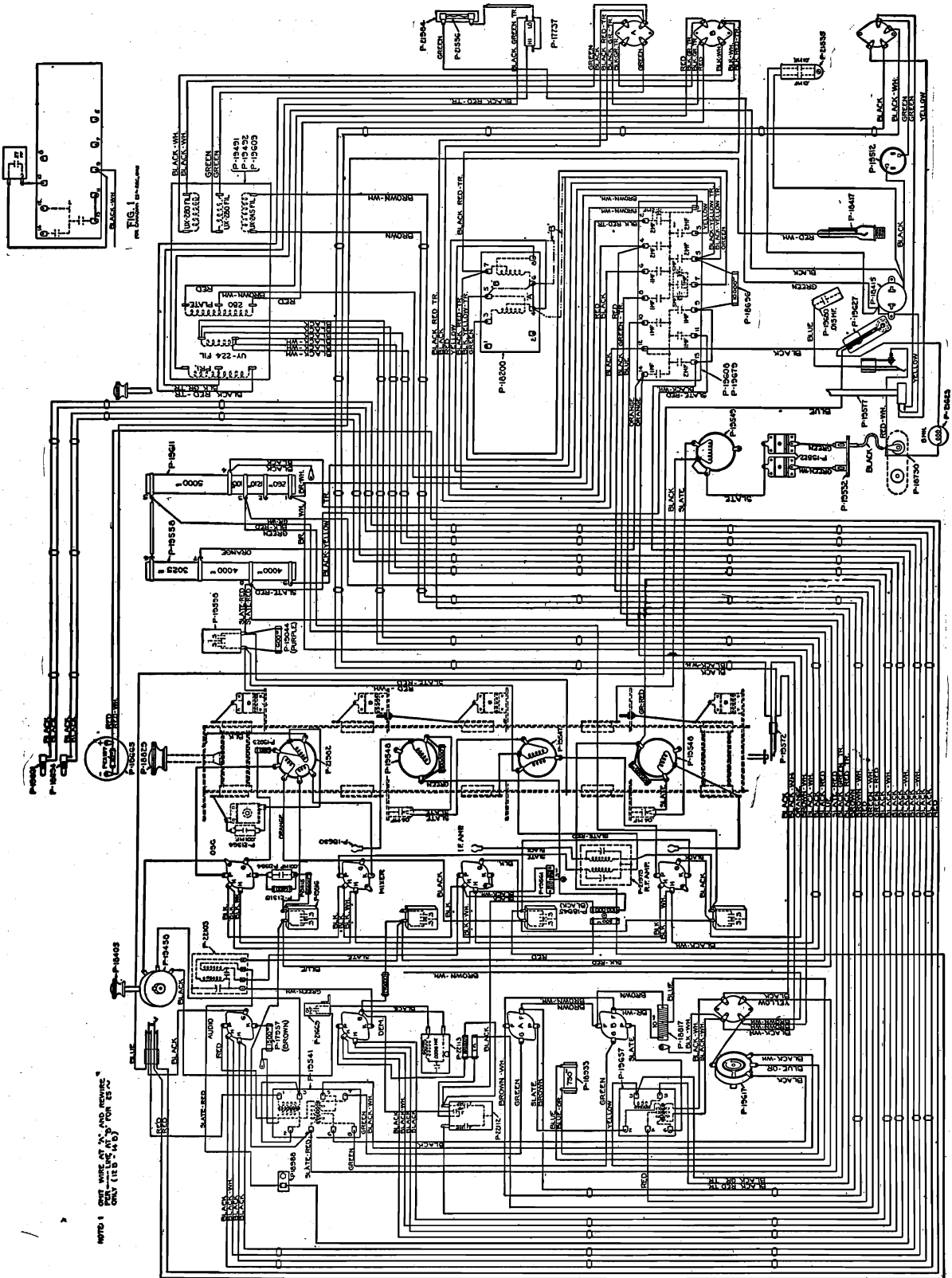

NOTE 1
 Omit wire at "A" and remove "B" only (12 5/8 x 5/8)

STROMBERG - CARLSON TEL. MFG. CO.

MODEL 27 AC Schematic

Schematic Circuit of No. 27 Superheterodyne Receiver

PEAK FREQUENCY 175 KC

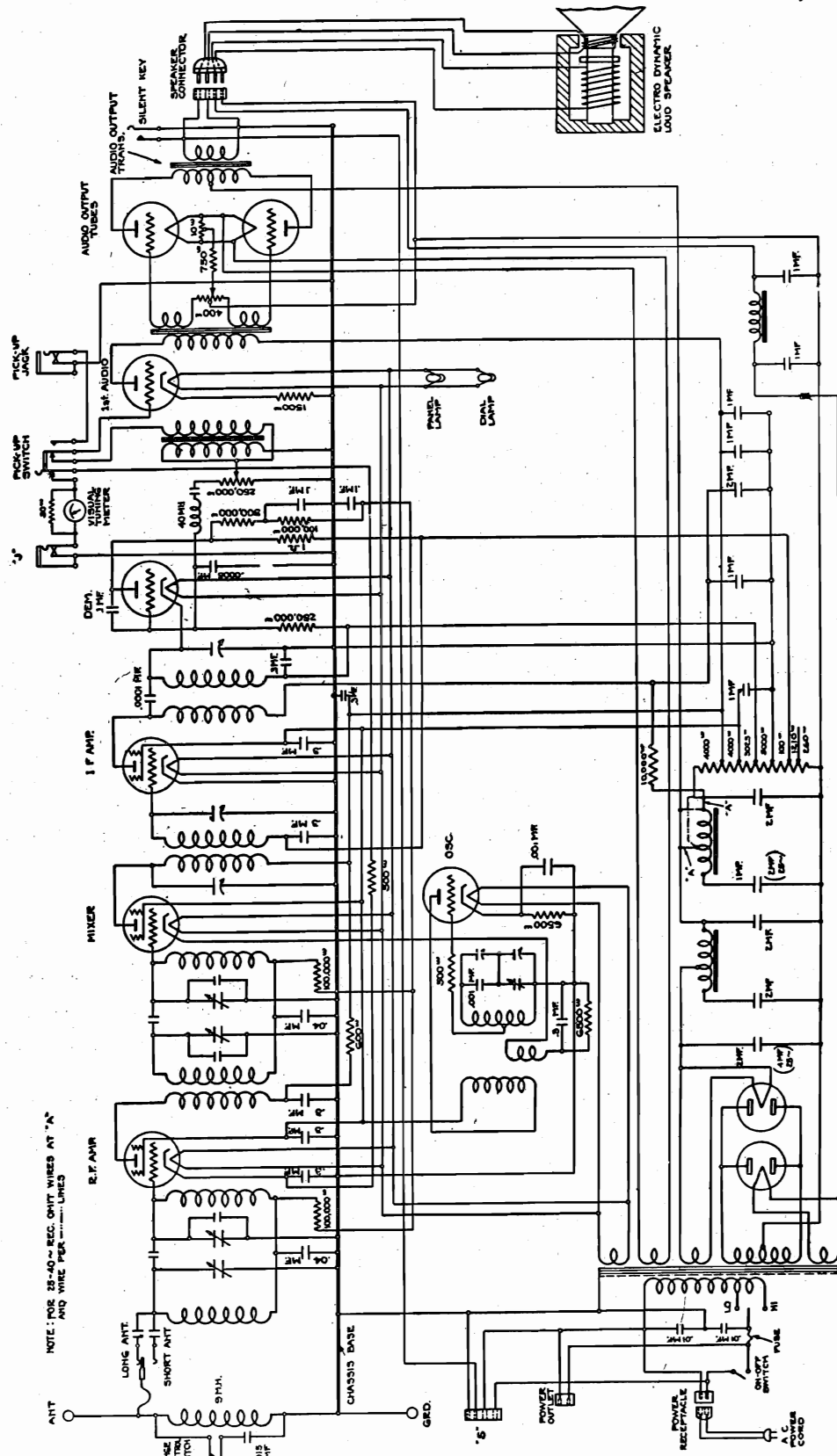

NOTE: FOR 25-40 REC. OHIT WIRES AT "A" AND WIRE PER LINES

STROMBERG - CARLSON TEL. MFG. CO.

MODEL 27
Voltage
Parts List

Part Number	Name of Part	Description of Part	Required per Receiver	Part Number	Name of Part	Description of Part	Required per Receiver
P-18429	Knob, Station Selector	Large Moulded Knob	1	P-19541	Audio Transformer Assembly	First Audio and Push-Pull Input Transformer	1
P-18465	Knob, Volume Control, On-Off and Silent Key	Small Moulded Knob	3	P-19657	Audio Output Transformer	Push-Pull Output Transformer	1
P-19665	Meter	Visual Tuning Meter	1	P-18730	Binding Post Assembly	Antenna and Ground Binding Post	1
P-19735	Pick-up Head	Low Impedance Magnetic Pick-up	1	P-19504	Bracket Assembly	Carbon Resistor Mounting	4
P-19656	Pin Plug Assembly	Antenna Pin Tip	1	P-18964	Bracket Assembly	Pilot Lamp Socket Mounting	1
P-19532	Pin Jack	Antenna Pin Jacks	1	P-18937	Cap	Voltage Divider Mounting	2
List 3027	Plug	Pick-up Cord Plug	1	P-19522	Capacitor, Aligning	Aligning Capacitor Covers	8
P-19673	Potentiometer	Phonograph Volume Control	1	P-19521	Capacitor, Aligning	Aligning Capacitor for Bi-Resonator Circuits	3
P-19617	Potentiometer	Hum Balancer	1	P-19520	Capacitor, Aligning	Detector Stage Aligning Capacitor	1
P-18415	Receptacle, Convenience Outlet	Power Supply Outlet—Rear of Chassis	1	P-21964	Capacitor, Aligning	Antenna Aligning Capacitor	2
P-19512	Receptacle, Supply Cord	Input Power Supply Receptacle	1	P-19516	Capacitor Assembly	Oscillator Series Tuning Capacitor	1
P-21562	Resistor, 1 Megohm	Carbon Type, Brown-Black-Green	1	P-19598	Capacitor Assembly	Radio Bi-Pass Capacitors—Two .3 MF Units	4
P-21697	Resistor, 500,000 ohms	Carbon Type, Green-Black-Yellow	1	P-22112	Capacitor Assembly	Radio Bi-Pass Capacitors—Three .1 MF Units	1
P-21561	Resistor, 250,000 ohms	Carbon Type, Red-Green-Yellow	1	P-19608	Capacitor Assembly	Filter Capacitor Block—60 Cycle	1
P-19533	Resistor, 100,000 ohms	Carbon Type, Brown-Black-Yellow	2	P-19679	Capacitor Assembly	Filter Capacitor Block—25 Cycle	1
P-18945	Resistor, 100,000 ohms	Carbon Type, Black	1	P-19452	Capacitor	Bi-Resonator Coupling Capacitor—04 MF	1
P-18696	Resistor, 10,000 ohms	Carbon Type, Blue	1	P-19680	Capacitor	Range Control Capacitor—.015 MF	1
P-21315	Resistor, 6,500 ohms	Carbon Type, Blue-Green-Red	2	P-21334	Capacitor	Fixed Capacitor—.001 MF	1
P-19044	Resistor, 600 ohms	Carbon Type, Brown	1	P-21535	Capacitor	Line Filter Across A. C. Input	1
P-19023	Resistor, 500 ohms	Carbon Type, Pink	2	P-21364	Capacitor	Series Tuning Oscillator Tuning	1
P-18817	Resistor, 10 ohms	Wire Wound (mid-tap)	1	P-19549	Coil Assembly R. F.	First Coil of First Bi-Resonator	1
P-19561	Resistor, 3 ohms	Wire Wound (mid-tap)	1	P-19548	Coil Assembly R. F.	Second Coil of First and Second Bi-Resonators	2
P-19558	Resistor, 11,025 ohms	Voltage Divider (Vitreous Enamelled)	1	P-19547	Coil Assembly R. F.	First Coil of Second Bi-Resonator	1
P-19611	Resistor, 6,570 ohms	Voltage Divider (Vitreous Enamelled)	1	P-21982	Coil Assembly, Oscillator	Oscillator Tuning Inductor	1
P-18933	Resistor, 750 ohms	Vitreous Enamelled Type	1	P-21975	Coil and Capacitor Assembly	First I. F. Transformer	1
P-19572	Silent Tuning Key	Silent Tuning Key Assembly	1	P-22103	Coil and Capacitor Assembly	Second I. F. Transformer	1
P-19508	Socket	UX Type (4 Prong)	5	P-18746	Cone and Moving Coil Assembly	Moving Element of P-19410 Dynamic Speaker	1
P-19507	Socket	UY Type (5 Prong)	7	P-19502	Cord	Power Supply Cord to Chassis	1
P-19410	Speaker	Complete Assembly—10" Cone	1	P-19415	Cord	Speaker Connector Cord	1
P-17737	Switch	Hi-Lo Switch	1	P-19629	Dial	Station Selector Dial	1
P-19577	Switch	On-Off Switch on Local-Distance Switch Assembly	1	P-19486	Drive Assembly	Driving Unit for Gang Tuning Capacitor Assembly	1
P-19491	Transformer, Power	60 Cycle, 110 Volt	1	P-18701	Escutcheon Assembly	Selector Dial Escutcheon	1
P-19492	Transformer, Power	25-60 Cycle, 110 Volt	1	P-22113	Filter Assembly	Demodulator Plate Filter	1
P-19609	Transformer, Power	25-60 Cycle, 220 Volt	1	P-19627	Frame and Spring Assembly	Pick-up Jack	1
P-18957	Transformer, Pick-up	Pick-up Input Transformer	1	P-19630	Grid Clip	Control Grid Clips for Tetrodes	3
P-19458	Volume Control Assembly	Volume Control and Phonograph Switch Assembly	1	P-18200	Inductor Assembly	Filter Inductor Assembly—Double "B" Choke	1
				P-18417	Jack	Remote Control Jack	1

Voltage	Meter	Scale	Where Measured	Approx. Value in Volts	Voltage	Meter	Scale	Where Measured	Approx. Value in Volts
Heater Voltages No. 224 and 227 Tubes	A. C.	0-4	Across Heater Terminals of 224 and 227 Tube Sockets	2.4	Screen Voltages R. F. Mixer and I. F. Tubes	D. C.	0-250	Between Screen Terminals of R. F. Mixer and I. F. Sockets (+) and Chassis Base (-)	75-90
Filament Voltages No. 245 Tubes	A. C.	0-4	Across Filament Terminals of Audio Output Sockets	2.4	"B" Voltages R. F. Mixer and 1st A. F. Tubes	D. C.	0-250	Between Terminal 8 on Voltage Divider (+) and Chassis Base (-)	110-165
Filament Voltages No. 280 Tubes	A. C.	0-8	Across Filament Terminals of Rectifier Tube Sockets	4.8	"B" Voltage Oscillator Tube	D. C.	0-250	Between Screen Terminal of Mixer Tube Socket (+) and Chassis Base (-)	75-90
Plate Voltage R. F. Tube	D. C.	0-250	Between Plate Terminal of R. F. Amplifier Socket (+) and Chassis Base (-)	140-165	"B" Voltage I. F. Tube	D. C.	0-250	Between Terminal 9 on Capacitor Assembly (+) and Chassis Base (-)	210-230
Plate Voltage Mixer Tube	D. C.	0-250	Between Plate Terminal of Mixer Socket (+) and Chassis Base (-)	140-165	"B" Voltage Audio Output Tubes	D. C.	0-750	Between Terminal 1 on Output Transformer (+) and Chassis Base (-)	248-268
Plate Voltage Oscillator Tube	D. C.	0-250	Between Plate Terminal of Oscillator Socket (+) and Chassis Base (-)	75-90	"C" Voltage I. F. Tube	D. C.	0-10	Between Terminals 3 (-) and 1 (+) on Voltage Divider	2.0
Plate Voltage I. F. Tube	D. C.	0-250	Between Plate Terminal of I. F. Socket (+) and Chassis Base (-)	210-230	"C" Voltage Audio Output Tubes	D. C.	0-250	Across 750 ohm Biasing Resistor	65-55
Plate Voltage Demodulator Tube	D. C.	0-250	Between Plate Terminal of Demodulator Socket (+) and Chassis Base (-)	See Note A	Speaker Field Voltage	D. C.		Across Small Pins on Speaker Connector Socket	335-365
Plate Voltage 1st A. F. Tube	D. C.	0-250	Between Plate Terminal of 1st A. F. Socket (+) and Chassis Base (-)	110-125	Plate Voltage A. C. Per Anode No. 280 Rectifier Tubes	A. C.	0-150	Between Plate Terminals of Rectifier Tube Sockets and Terminal 1 on Voltage Divider	330-360
Plate Voltages Audio Output Tubes	D. C.	6-750	Between Plate Terminals of Audio Output Sockets (+) and Mid Tap of 10 ohm Resistor (-)	250-270					
"C" Voltage R. F. Tube	D. C.	6-110	Between Cathode Terminal of R. F. Socket (+) and Chassis Base (-)	2.4					
"C" Voltage Mixer Tube	D. C.	0-10	Between Cathode Terminal of Mixer Socket (+) and Chassis Base (-)	6.5					
Grid Voltage Oscillator Tube	D. C.	0-250	Between Cathode Terminal of Oscillator Socket (+) and Chassis Base (-)	27-35					
Control Grid Voltage I. F. Tube	D. C.	0-10	Between Control Grid Clip of I. F. Tube (-) and Cathode Terminal of I. F. Socket (+)	2.8					
Grid Voltage Demodulator Tube	D. C.	0-250	Between Cathode Terminal of Demodulator Socket (+) and Chassis Base (-)	45-55					
Grid Voltage 1st A. F. Tube	D. C.	0-10	Between Cathode Terminal of 1st A. F. Socket (+) and Chassis Base (-)	6.5					
Grid Voltage Audio Output Tube	D. C.	0-250	Between Grid Terminals of Audio Output Sockets (-) and Mid Tap of 10 ohm Resistor (+)	40-50					

NOTE: "A"—No voltage can be obtained across these terminals as the Demodulator Plate is connected to the Chassis Base through a 1 megohm and 100 ohm resistances.

NORMAL VOLTAGE READINGS

MODEL 29
Schematic

STROMBERG - CARLSON TEL. MFG. CO.

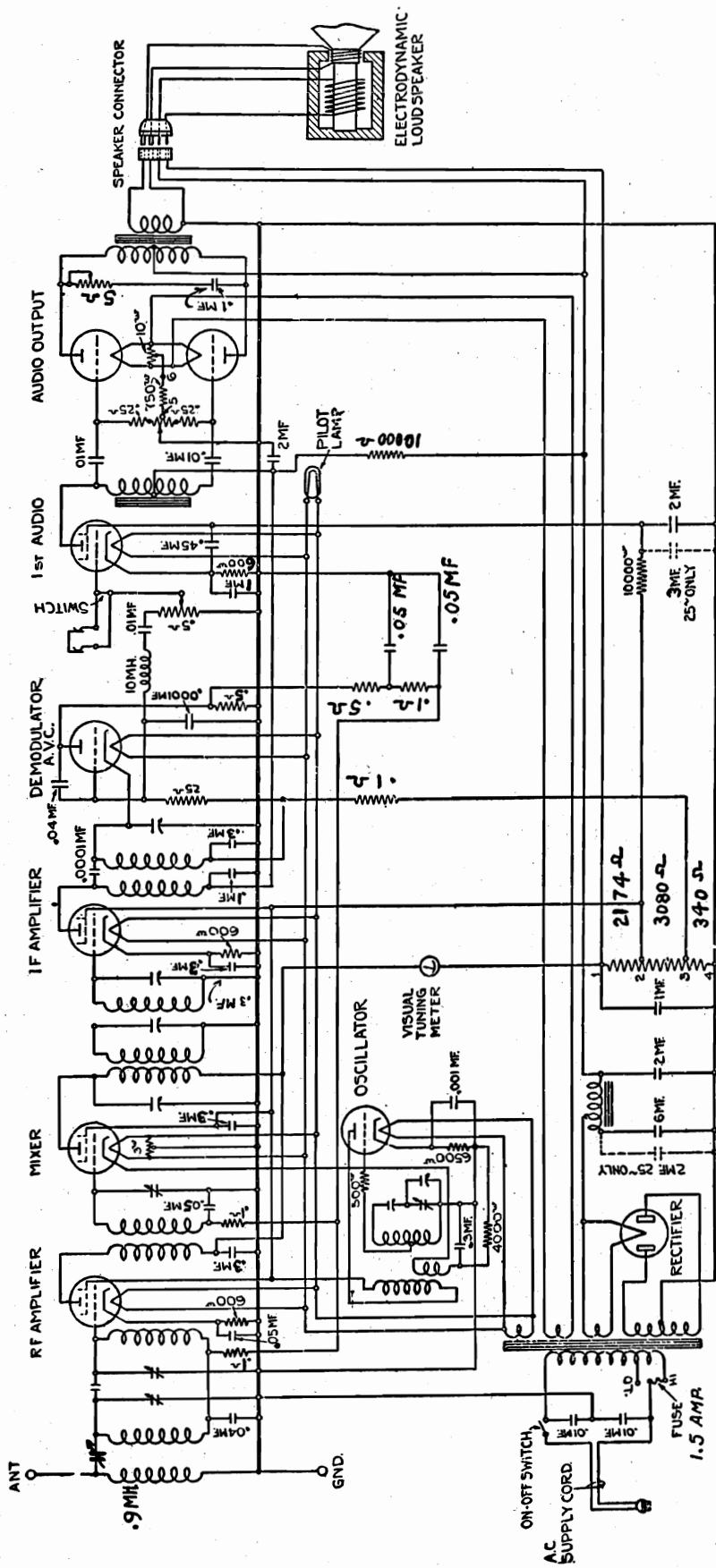

The Stromberg-Carlson No. 29 Radio Receiver is a Superheterodyne employing nine tubes. An improved Automatic Volume Control circuit with Visual Tuning Meter is incorporated.

Four No. 235 tubes are used as R. F. Amplifier, Mixer, I. F. Amplifier, and First Audio Amplifier. Two No. 227 tubes are used as Oscillator and Demodulator-AVC. Two No. 245 tubes are used in the push-pull output stage. A No. 280 Rectifier is used in the power supply.

A Bi-resonator is used to couple the antenna to the R. F. amplifier to prevent any cross modulation. The R. F. amplifier is coupled to the mixer by an ordinary tuned R. F. transformer. This gives three tuning circuits (four gang tuning capacitor) for R. F. selectivity ahead of the mixer, thus the image response ratio is exceedingly high. The oscillator is coupled to the cathode circuit of the mixer tube in the regular manner. The I. F. output of the mixer tube is fed into a Tri-resonator (three tuned circuit transformer) and thence to the I. F. amplifier tube. This tube is coupled to the duo-diode demodulator-AVC tube by a choke-tuned circuit arrangement. The audio output of the duo-diode is fed through a radio frequency filter to the resistor unit of the Manual Volume Control which acts as a coupling resistor to the audio amplifier. The A. V. C. voltages from the other diode circuit are led back to the control grids of the first two tubes. A No. 235 screen grid tube is used in the first audio stage to obtain high amplification without distortion.

Model 29 (1932)

RECT	○ '80	○ '27	○ '35	○ '35
	○ '45	○ '45	○ '35	○ '27
	○ '45	○ '35	○ '27	○ '35
PILOT 2.5 V.				
FRONT				

MODEL 29
Parts List
Voltage

STROMBERG - CARLSON TEL. MFG. CO.

REPLACEMENT PARTS

(See Chassis Assembly on Page 4 and Wiring Diagram on Page 2)

Piece Number	Part	Description of Part	Required per Receiver
P-22288	Audio Transformer	Audio Output Transformer	1
P-22289	Audio Transformer	Push-Full Transformer	1
P-21663	Bracket Assembly	Voltage Divider Mounting	1
P-22352	Capacitor	By-Pass Capacitor	1
P-22353	Capacitor, Aligning	Oscillator "Series Aligner"	1
P-21334	Capacitor	.001 Mfd.	1
P-21535	Capacitor	.01 Mfd.	1
P-21669	Capacitor	.01 Mfd.	3
Code No. 21	Capacitor	1 Mfd. Filter Capacitor	1
Code No. 22	Capacitor	2 Mfd. Filter Capacitor	1
P-19452	Capacitor	Bi-Resonator Coupling Capacitor .04 Mfd.	1
P-22411	Capacitor	.04 Mfd.	1
P-21262	Capacitor, Aligning	Aligner for First I. F. Transformer	1
P-22338	Capacitor Assembly	Filter Capacitor (60 Cycle)	1
P-22342	Capacitor Assembly	Filter Capacitor (25 Cycle)	1
P-22290	Coil and Capacitor Assembly	First I. F. Transformer	1
P-22291	Coil and Capacitor Assembly	Second I. F. Transformer	1
P-22358	Coil Assembly	First Coil of Bi-Resonator	1
P-22359	Coil Assembly	Second Coil of Bi-Resonator	1
P-22360	Coil Assembly	R. F. Transformer	1
P-22361	Coil Assembly	Oscillator Coil	1
P-21623	Coil Assembly	Antenna Inductor	1
P-21566	Fuse	1½ Amperes	1
P-19630	Grid Clip		4
P-21704	Grid Clip Assembly		2
P-21230	Inductor Assembly	Filter Inductor—"B" Choke	1
P-21277	Knob	Antenna Aligner	1
P-22390	Knob	Selector Knob	1
P-22391	Knob	Volume Control and Clarifier-Switch	2
P-22351	Meter	Visual Tuning Meter	1
P-19617	Potentiometer	Hum Adjuster	1
P-22318	Potentiometer and Switch	Volume Control and Phonograph Switch and Clarifier and "On-Off" Switch	2
P-19561	Resistor, 3-Ohms	Resistor across Heater of Mixer Tube	1
P-19817	Resistor, 10-Ohms	Resistor across Filament of Output Tubes	1
P-19023	Resistor, 500-Ohms, "C" Type	Carbon Resistor, Green, Black, and Brown	3
P-22327	Resistor, 600-Ohms, "C" Type	Carbon Resistor, Blue, Black, and Brown	1
P-22328	Resistor, 4,000-Ohms, "C" Type	Carbon Resistor, Yellow, Black, and Red	1
P-22329	Resistor, 6,500-Ohms, "C" Type	Carbon Resistor, Blue, Green, and Red	1
P-22355	Resistor, 7,344-Ohms, "B" Type	Voltage Divider	1
P-18696	Resistor, 10,000-Ohms, "B" Type	Carbon Resistor, Brown, Black, and Orange	1
P-22330	Resistor, 10,000-Ohms, "C" Type	Carbon Resistor, Brown, Black, and Orange	4
P-22333	Resistor, 100,000-Ohms, "D" Type	Carbon Resistor, Brown, Black and Yellow	2
P-21561	Resistor, 250,000-Ohms, "C" Type	Carbon Resistor, Red, Green, and Yellow	2
P-22334	Resistor, 250,000-Ohms, "D" Type	Carbon Resistor, Red, Green, and Yellow	2
P-22335	Resistor, 500,000-Ohms, "D" Type	Carbon Resistor, Green, Black, and Yellow	1
P-22344	Resistor and Coil Assembly	Demodulator Plate Filter	1
P-22346	Transformer	Power, 60 Cycle, 110 Volts	1
P-22347	Transformer	Power, 25-60 Cycle, 110 Volts	1

NORMAL VOLTAGE READINGS

These voltage readings correspond to a line voltage at 120 volts with the fuse in the "HI" position or 110 volts in the "LO" position. The fuse should be set in the proper position for the line voltage obtained before making measurements. When voltages are measured proper allowance should be made for a difference in line voltage above or below 110 or 120 volts. Be sure to make these readings with the Meter and Scale indicated, otherwise the results will not agree with those tabulated. Alternating voltages are indicated by italics.

Voltage	Meter	Scale	Where Measured	Approx. Value in Volts
Heater Voltages No. 227 and No. 235 Tubes	A. C.	0-4	Across Heater Terminals of Sockets	2.45
Filament Voltage No. 245 Tubes	A. C.	0-4	Across Filament of Audio Output Socket	2.45
Plate Voltage Radio Amplifiers	D. C.	0-250	Between Plate Terminal of E. F. Amplifier Socket (+) and Chassis Base	170
Plate Voltage Mixer Tube	D. C.	0-250	Between Plate Terminal of Mixer Socket (+) and Chassis Base (-)	170
Plate Voltage Oscillator Tube	D. C.	0-250	Between Plate Terminal of Oscillator Tube Socket (+) and Chassis Base (-)	87
Plate Voltage I. F. Tube	D. C.	0-250	Between Plate Terminal of First I. F. Socket (+) and Chassis Base (-)	220
Plate Voltage First Audio Tube	D. C.	0-250	Between Plate Terminal of First Audio Socket (+) and Chassis Base (-)	192
Plate Voltage Audio Output Tubes	D. C.	0-750	Between Plate Terminals of Audio Output Sockets (+) and Midtap 10-Ohm Resistor Midtap (-)	250
"C" Voltage R. F. Amplifier	D. C.	0-10	Between Cathode Terminal of R. F. Amplifier Socket (+) and Chassis Base (-)	3
"C" Voltage Mixer Tube	D. C.	0-10	Between Cathode Terminal of Mixer Socket (+) and Chassis Base (-)	3
"C" Voltage I. F. Amplifier	D. C.	0-10	Between Cathode Terminal I. F. Socket (+) and Chassis Base (-)	3
Grid Voltage Oscillator Tube	D. C.	0-250	Between Cathode Terminal of Oscillator Socket (+) and Chassis Base (-)	14-18
Plate Voltage Demodulator Tube	D. C.	0-250	Between Voltage Divider Terminal No. 3 (+) and Chassis Base (-)	12.5
Screen Voltages of R. F. Amplifier, Mixer, and I. F. Amplifier	D. C.	0-250	Between Screen Terminals on Sockets (+) and Chassis Base (-)	57.
"B" Voltage R. F. Amplifier	D. C.	0-250	Between High Side Voltage Divider (+) and Chassis Base (-)	175
"B" Voltage I. F. Amplifier and First Audio Tube	D. C.	0-250	Between Midtap First Audio Transformer (+) and Chassis Base (-)	225
"B" Voltage Output Tubes	D. C.	0-750	Between Midtap on Output Transformer (+) and Chassis Base (-)	265
"C" Voltage First A. F. Tube	D. C.	0-10	Between Cathode of First A. F. Tube (+) and Chassis Base (-)	3
"C" Voltage Output Tubes	D. C.	0-250	Across 750-Ohm Biasing Resistor	50
Speaker Field Voltage	D. C.	0-250	Across Small Pins on Speaker Connector Socket	127.5
Plate Voltage A. C. Fer Anode No. 280 Rectifier Tube	A. C.		Between Plate Terminals of No. 280 Rectifier Socket and Chassis Base	340
Filament Voltage No. 230 Rectifier Tube	A. C.	0-8	Between Filament Terminals of No. 230 Rectifier Socket	4.9

MODEL 38,39,40

1st Type
Parts List
Voltage

STROMBERG - CARLSON TEL. MFG. CO.

NORMAL VOLTAGE READINGS

These voltage readings correspond to a line voltage at 120 volts.

Voltage	Meter	Scale	Where Measured	Approx. Value in Volts
Heater Voltages No. 56 and No. 58 Tubes	A. C.	0-4	Across Heater Terminals of Sockets	2.5
Filament Voltages No. 245 Tubes	A. C.	0-4	Across Filament Terminals of Audio Output Sockets	2.5
Filament Voltage No. 280 Tube	A. C.	0-8	Across Filament Terminals of No. 280 Rectifier Socket	5.
Plate Voltage Radio Amplifier Tube	D. C.	0-250	Between Plate Terminal of R. F. Amplifier Socket (+) and Chassis Base (-)	165
Plate Voltage Mixer Tube	D. C.	0-250	Between Plate Terminal of Mixer Socket (+) and Chassis Base (-)	150
Plate Voltage Oscillator Tube	D. C.	0-250	Between Plate Terminal of Oscillator Socket (+) and Chassis Base (-)	80
Plate Voltage I. F. Tube	D. C.	0-250	Between Plate Terminal of I. F. Socket (+) and Chassis Base (-)	170
Plate Voltage Demodulator Tube	D. C.	0-250	Between Plate Terminal and Demodulator Socket (+) and Chassis Base (-)	0
Plate Voltage First Audio Tube	D. C.	0-250	Between Plate Terminal of First Audio Socket (+) and Chassis Base (-)	160
Plate Voltages Audio Output Tubes	D. C.	0-250	Between Plate Terminals of Audio Output Sockets (+) and Chassis Base (-)	285
"C" Voltage R.F. Amplifier Tube	D. C.	0-10	Between Cathode Terminal of R. F. Amplifier Socket (+) and Chassis Base (-)	6
"C" Voltage Mixer Tube	D. C.	0-10	Between Cathode Terminal of Mixer Socket (+) and Chassis Base (-)	8
"C" Voltage Oscillator Tube	D. C.	0-250	Between Cathode Terminal of Oscillator Socket (+) and Chassis Base (-)	25
"C" Voltage I. F. Tube	D. C.	0-10	Between Cathode Terminal of I. F. Socket (+) and Chassis Base (-)	3
"C" Voltage Demodulator Tube	D. C.	0-10	Between Cathode Terminal of Demodulator (+) and Chassis Base (-)	2.5-3
"C" Voltage First Audio Tube	D. C.	0-10	Between Cathode Terminal of First Audio Socket (+) and Chassis Base (-)	6.5
"C" Voltage Audio Output Tube	D. C.	0-250	Across 750 ohm Biasing Resistor	47
Screen Voltages R. F. Mixer and I. F. Tubes	D. C.	0-250	Between Screen Terminals on Sockets (+) and Chassis Base (-)	85
"B" Voltage R. F. Mixer, I. F. First Audio and Demodulator Tube	D. C.	0-250	Between High Side of Voltage Divider (+) and Chassis Base (-)	160
"B" Voltage Audio Output Tubes	D. C.	0-750	Between Mid-Tap of Output Transformer (+) and Chassis Base (-)	300
Speaker Field Volts	D. C.	0-250	Across Small Pins on Speaker Connector Socket	125
Plate Voltage A. C. per Anode No. 280 Rectifier Tube	A. C.		Between Plate Terminals of No. 280 Rectifier Socket and Chassis Base	340

REPLACEMENT PARTS

Piece Number	Part	Description of Part	Required per Receiver
P-22540	Audio Transformer Assembly	Input and Output Push-Pull Transformer	1
P-21663	Bracket Assembly	Voltage Divider Mounting	1
P-22353	Capacitor	Oscillator "Series Aligner"	1
P-21334	Capacitor	.001 Mfd.	2
P-22557	Capacitor	.004 Mfd.	1
P-19597	Capacitor	.04 Mfd.	1
P-21535	Capacitor	2-.01 Mfd.	1
P-22411	Capacitor	.04 Mfd.	2
P-22556	Capacitor	Aligner in Tri-Resonator	1
P-22565	Capacitor Assembly	R. F. and I. F. By-Pass Capacitors	1
P-22544	Capacitor Assembly	Filter Capacitor Assembly	1
P-22549	Coil	Tri-Resonator Circuit and Demodulator Plate Circuit	2
P-22358	Coil Assembly	First Coil of Bi-Resonator	1
P-22359	Coil Assembly	Second Coil of Bi-Resonator	1
P-22360	Coil Assembly	R. F. Transformer	1
P-22361	Coil Assembly	Oscillator Coil	1
P-21623	Coil Assembly	Antenna Inductor	1
P-21566	Fuse	1.5 Amperes	1
P-19630	Grid Clip		1
P-21704	Grid Clip Assembly		2
P-22532	I. F. Transformer	First I. F. Transformer	1
P-22533	I. F. Transformer	Second I. F. Transformer	1
P-21277	Knob	Antenna Aligner	1
P-22390	Knob	Selector Knob	1
P-22391	Knob	Volume Control and Clarifier Switch	2
P-22351	Meter	Visual Tuning Meter (Weston No. 654)	1
P-19617	Potentiometer	Hum Adjuster	1
P-22593	Potentiometer	Clarifier and On-Off Switch	1
P-22546	Potentiometer	Dual Volume Control and Phonograph Switch	1
P-22550	Resistor, 150 Ohms	Filter Resistor	1
P-22596	Resistor, 5370 Ohms	Voltage Divider	1
P-21621	Resistor, 1,000 Ohms, "C" Type	Carbon Resistor, Brown, Black and Red	1
P-22329	Resistor, 6,500 Ohms, "C" Type	Carbon Resistor, Blue, Green and Red	1
P-22327	Resistor, 800 Ohms, "C" Type	Carbon Resistor, Blue, Black and Brown	3
P-22328	Resistor, 4,000 Ohms, "C" Type	Carbon Resistor, Yellow, Black and Red	3
P-22330	Resistor, 10,000 Ohms, "C" Type	Carbon Resistor, Brown, Black and Orange	1
P-22331	Resistor, 15,000 Ohms, "C" Type	Carbon Resistor, Brown, Green and Orange	1
P-22343	Resistor, 100,000 Ohms, "D" Type	Carbon Resistor, Brown, Black and Yellow	4
P-22334	Resistor, 250,000 Ohms, "D" Type	Carbon Resistor, Red, Green and Yellow	1
P-22561	Resistor, 1 Megohm, "D" Type	Carbon Resistor, Brown, Black and Green	1
P-21230	4 Pin Socket		4
P-22570	5 Pin Socket		2
P-22571	6 Pin Socket		4
P-22529	Transformer	Power, 60 Cycle, 110 Volts	1
P-22530	Transformer	Power, 25-60 Cycles, 110 Volts	1

MODEL 641

Resistance Data STROMBERG-CARLSON TEL. MFG. CO.

All tubes removed from sockets and AC plug removed from power supply lead.
 Speaker field disconnected. Volume control maximum unless otherwise stated.
 Pickup disconnected

From Chassis To	Correct	Incorrect
Aerial (V.C.Max)	17 ohms	
Aerial (V.C. Varied)	0-5000 ohms*	*Antenna volume control is 20,000 ohms
1 RF Control Grid	3.8 ohms	TC- 1 rf Cg-Y
1 RF Cathode	164 ohms	BC- 1 rfK-Y (.3 mfd)
1 RF Screen	3,781 ohms	BC- 1 rf Sg-Y (.3 mfd)
1 RF Plate	8,297 ohms	BC- 1 rf P-Y (.3 mfd)
		BC- VD-Y (1. mfd)
		BC- 2 rf P-Y (.3 mfd)
		BC- 3 rf P-Y (.3 mfd)
1 RF Plate to 2 RF Plate	34 ohms	
2 RF Control Grid	3.5 ohms	TC- 2 rf Cg-Y
2 RF Cathode	164 ohms	See 1 RF Cathode
2 RF Screen	3,781 ohms	See 1 RF Screen
2 RF Plate	8,297 ohms	See 1 RF Plate
2 RF Plate to 1 RF Plate	34 ohms	
3 RF Control Grid	3.5 ohms	TC- 3 rf K-Y
3 RF Cathode	390 ohms	BC- 3 rf K-Y (.3 mfd)
3 RF Screen	3,781 ohms	See 1 RF Screen
3 RF Plate	8,297 ohms	See 1 RF Plate
Detector Control Grid	2,000,000 ohms	Also 3.5 ohms grid winding Grid condenser
Detector Cathode	15,000 ohms	BC- DK-Y (1.mfd)
Detector Plate	28,000 ohms	BC-DP-Y
		BC- AF Tr-Y (1 mfd)
		See RF Screen
		FC- Filter chk-Y
Detector Plate to '80 Fil	12,720 ohms	FC- Filter chk-Y
		See Detector Plate
'45 Control Grid	9,570 ohms	
'45 Fil to chassis	1,452 ohms	
'45 Plate to 80 Fil	1,403 ohms	BC- across tone filter. (2-.01 mfd)
		FC- Filter chk-Y
Across Speaker Terminals	1.7 ohms	
80 Fil to chassis	16,881 ohms	See Detector Plate
		FC- Tuned Filter chk-Y

641,

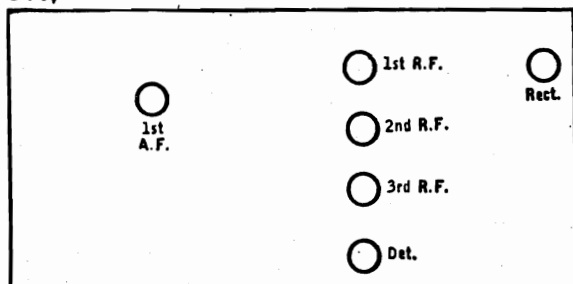

STROMBERG-CARLSON—Model 641
 Line Voltage 114—Set on High Volt Tap—Volume Control Position Max

TUBE NO IN ORDER	TYPE OF TUBE	POSITION OF TUBE 1ST RF SET ETC	READINGS PLUG IN SOCKET OF SET										
			TUBE OUT					TUBE IN TESTER					
			A VOLTS	B VOLTS	C VOLTS	D VOLTS	E VOLTS	CATHODE HEATER VOLTS	NORMAL PLATE MA	TEST MA	PLATE MA	PLATE MA	SCREEN MA
224	1st RF		2.45	140	2.24	136	3.5	3.5	1.5	4	2.5	5	5
224	2nd RF		2.45	140	2.24	136	3.5	3.5	1.5	4	2.5	5	5
224	3rd RF		2.45	140	2.24	136	3.5	3.5	1.5	4	2.5	5	5
227	Det.		2.45	278	2.24	248	3	3	1.8	-	-	-	-
245	Amp.		2.45	355	2.24	238	35		30	32	P	C	

STROMBERG - CARLSON TEL. MFG. CO.

MODEL 846
Resistance Data

846 Cont'd

All tubes removed from receiver and AC power plug disconnected from supply circuit. Pickup switch in radio position.

From Chassis To	Correct	Incorrect
Aerial (V.C.Min)	10 ohms	
Aerial (V.C.Max)	20 ohms	
Aerial (V.C. Halfway)	5,000 ohms	approx Variable antenna V.C. has a value of 20,000 ohms
1 RF Tuning Condenser Stator	3.8 ohms	TC-Y
1 RF Control Grid	5,200,000 ohms	BLC- 1 rf Cg-grid wdg BC- 5 meg unit-Y BLC- AVC P-Y (.5 mfd) BC- 1 rf K-Y (.3 mfd) BC- 1 rf SG-Y (.3 mfd) BC- 2 rf SG-Y (.3 mfd) BC- 3 rf SG-Y (.5 mfd) BC- 1 rf P-Y (.3 mfd) BC- 2 rf P-Y (.3 mfd) BC- 3 rf P-Y (.3 mfd) FC- V D-Y (1.mfd)
1 RF Cathode	390 ohms	TC-Y
1 RF Screen	4,350 ohms	BLC- 2 rf Cg-grid wdg BC- 5 meg unit-Y BLC- AVC P-Y (.5 mfd) See 1 RF Screen
1 RF Plate	10,367 ohms	*DC Resistance of visual tuning meter must be added BC- 2 rf K-Y (.3 mfd) See 1 RF Plate TC-Y
2 RF Tuning Condenser Stator	3.5 ohms	BLC- 3 rf Cg-grid wdg BC- 3 rf K-Y (.3 mfd) See 1 RF Screen
2 RF Control Grid	5,100,000 ohms	TC-Y
2 RF Cathode	390 ohms	BC across bias unit (1 mfd)
2 RF Screen	4,380 ohms	BC D P-Y
2 RF Plate	10,367 ohms	FC- AF Tr-80 P wdg FC- 10,000 ohm unit-80 P wdg FC- Tuned Filter ohk FC- 80 P-80 P wdg 250,000 ohm V.C.
3 RF Tuning Condenser Stator	5,000,000 ohms	BC- AF Tr-Y (1 mfd)
3 RF Control Grid	600 ohms	*Two windings of transformer do not have like resistance. One half has 9890 ohms and other half
3 RF Cathode	4,350 ohms	
3 RF Screen	10,367 ohms	
3 RF Plate	2,055 ohms	
Detector Control Grid	6 ohms	
Detector Cg to Det F	15,003 ohms	
Detector Cathode	17,080 ohms	
Detector Plate	27,830 ohms	
1 AF Control Grid (V.C.Max)	4,913 ohms	
1 AF Cathode	1,500 ohms	
1 AF Plate	13,730 ohms	
2 AF Control Grid	20,840 or 11,920 ohms*	

From Chassis To	Correct	Incorrect
2 AF Control Grid to Control Grid	24,700 ohms	has 14,610 ohms
2 AF Filament	2,755 ohms	BC-across 725 ohm unit
2 AF Plate to Plate	886 ohms	FC-Tuned Filter ohk
2 AF Plate to 80 Fil	825-900- ohms	FC-Filter ohk-
Across speaker terminals only	1.77ohms	
AVC Control Grid	2,002,030 ohms	BC- 2 meg unit-Y CC- AVC Cg- 3 rf P BC- AVC K-Y BC- AVC P-Y (.5 mfd) FC
AVC Cathode	1,700 ohms	
AVC Plate	200,000 ohms	
180 Filament	14,200-14,300 ohms	
180 Filament to 80 Anode	16,340-16,440 ohms	

Note* Speaker power supply checked separately

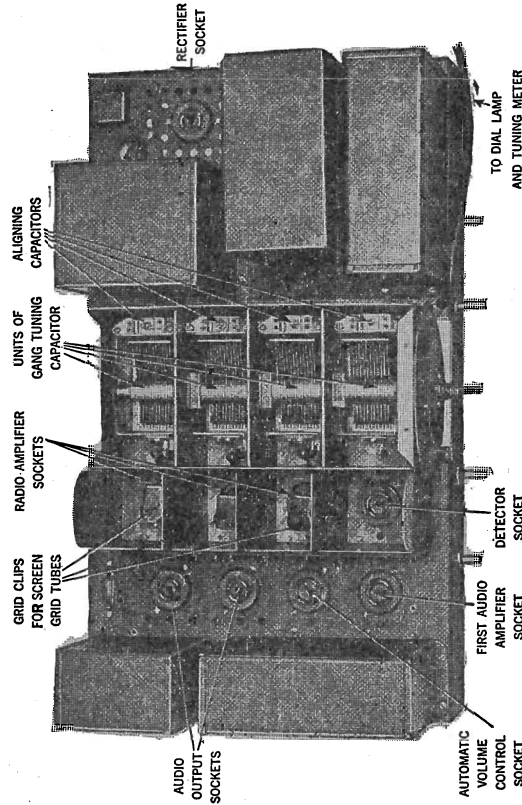

*A very slight deflection of the meter only. Readings given are for either of the 2 tubes used in Push Pull

TUBE	TYPE	RESISTANCE	TUBE OFF		TUBE IN TESTER		MEASUREMENT MADE IN SERIES OF MET	
			BY V.C.	BY V.C.	BY V.C.	BY V.C.	BY V.C.	BY V.C.
1	2A4	2,755	2,755	2,755	2,755	2,755	2,755	2,755
2	2A4	2,755	2,755	2,755	2,755	2,755	2,755	2,755
3	2A4	2,755	2,755	2,755	2,755	2,755	2,755	2,755
4	2A4	2,755	2,755	2,755	2,755	2,755	2,755	2,755
5	2A4	2,755	2,755	2,755	2,755	2,755	2,755	2,755
6	2A4	2,755	2,755	2,755	2,755	2,755	2,755	2,755
7	2A4	2,755	2,755	2,755	2,755	2,755	2,755	2,755
8	2A4	2,755	2,755	2,755	2,755	2,755	2,755	2,755
9	2A4	2,755	2,755	2,755	2,755	2,755	2,755	2,755
10	2A4	2,755	2,755	2,755	2,755	2,755	2,755	2,755
11	2A4	2,755	2,755	2,755	2,755	2,755	2,755	2,755
12	2A4	2,755	2,755	2,755	2,755	2,755	2,755	2,755
13	2A4	2,755	2,755	2,755	2,755	2,755	2,755	2,755
14	2A4	2,755	2,755	2,755	2,755	2,755	2,755	2,755
15	2A4	2,755	2,755	2,755	2,755	2,755	2,755	2,755
16	2A4	2,755	2,755	2,755	2,755	2,755	2,755	2,755
17	2A4	2,755	2,755	2,755	2,755	2,755	2,755	2,755
18	2A4	2,755	2,755	2,755	2,755	2,755	2,755	2,755
19	2A4	2,755	2,755	2,755	2,755	2,755	2,755	2,755
20	2A4	2,755	2,755	2,755	2,755	2,755	2,755	2,755
21	2A4	2,755	2,755	2,755	2,755	2,755	2,755	2,755
22	2A4	2,755	2,755	2,755	2,755	2,755	2,755	2,755
23	2A4	2,755	2,755	2,755	2,755	2,755	2,755	2,755
24	2A4	2,755	2,755	2,755	2,755	2,755	2,755	2,755
25	2A4	2,755	2,755	2,755	2,755	2,755	2,755	2,755
26	2A4	2,755	2,755	2,755	2,755	2,755	2,755	2,755
27	2A4	2,755	2,755	2,755	2,755	2,755	2,755	2,755
28	2A4	2,755	2,755	2,755	2,755	2,755	2,755	2,755
29	2A4	2,755	2,755	2,755	2,755	2,755	2,755	2,755
30	2A4	2,755	2,755	2,755	2,755	2,755	2,755	2,755
31	2A4	2,755	2,755	2,755	2,755	2,755	2,755	2,755
32	2A4	2,755	2,755	2,755	2,755	2,755	2,755	2,755
33	2A4	2,755	2,755	2,755	2,755	2,755	2,755	2,755
34	2A4	2,755	2,755	2,755	2,755	2,755	2,755	2,755
35	2A4	2,755	2,755	2,755	2,755	2,755	2,755	2,755
36	2A4	2,755	2,755	2,755	2,755	2,755	2,755	2,755
37	2A4	2,755	2,755	2,755	2,755	2,755	2,755	2,755
38	2A4	2,755	2,755	2,755	2,755	2,755	2,755	2,755
39	2A4	2,755	2,755	2,755	2,755	2,755	2,755	2,755
40	2A4	2,755	2,755	2,755	2,755	2,755	2,755	2,755
41	2A4	2,755	2,755	2,755	2,755	2,755	2,755	2,755
42	2A4	2,755	2,755	2,755	2,755	2,755	2,755	2,755
43	2A4	2,755	2,755	2,755	2,755	2,755	2,755	2,755
44	2A4	2,755	2,755	2,755	2,755	2,755	2,755	2,755
45	2A4	2,755	2,755	2,755	2,755	2,755	2,755	2,755
46	2A4	2,755	2,755	2,755	2,755	2,755	2,755	2,755
47	2A4	2,755	2,755	2,755	2,755	2,755	2,755	2,755
48	2A4	2,755	2,755	2,755	2,755	2,755	2,755	2,755
49	2A4	2,755	2,755	2,755	2,755	2,755	2,755	2,755
50	2A4	2,755	2,755	2,755	2,755	2,755	2,755	2,755

SUPREME INSTRUMENTS CORP.

MODEL 400-B
#4 Series
Diagnomer

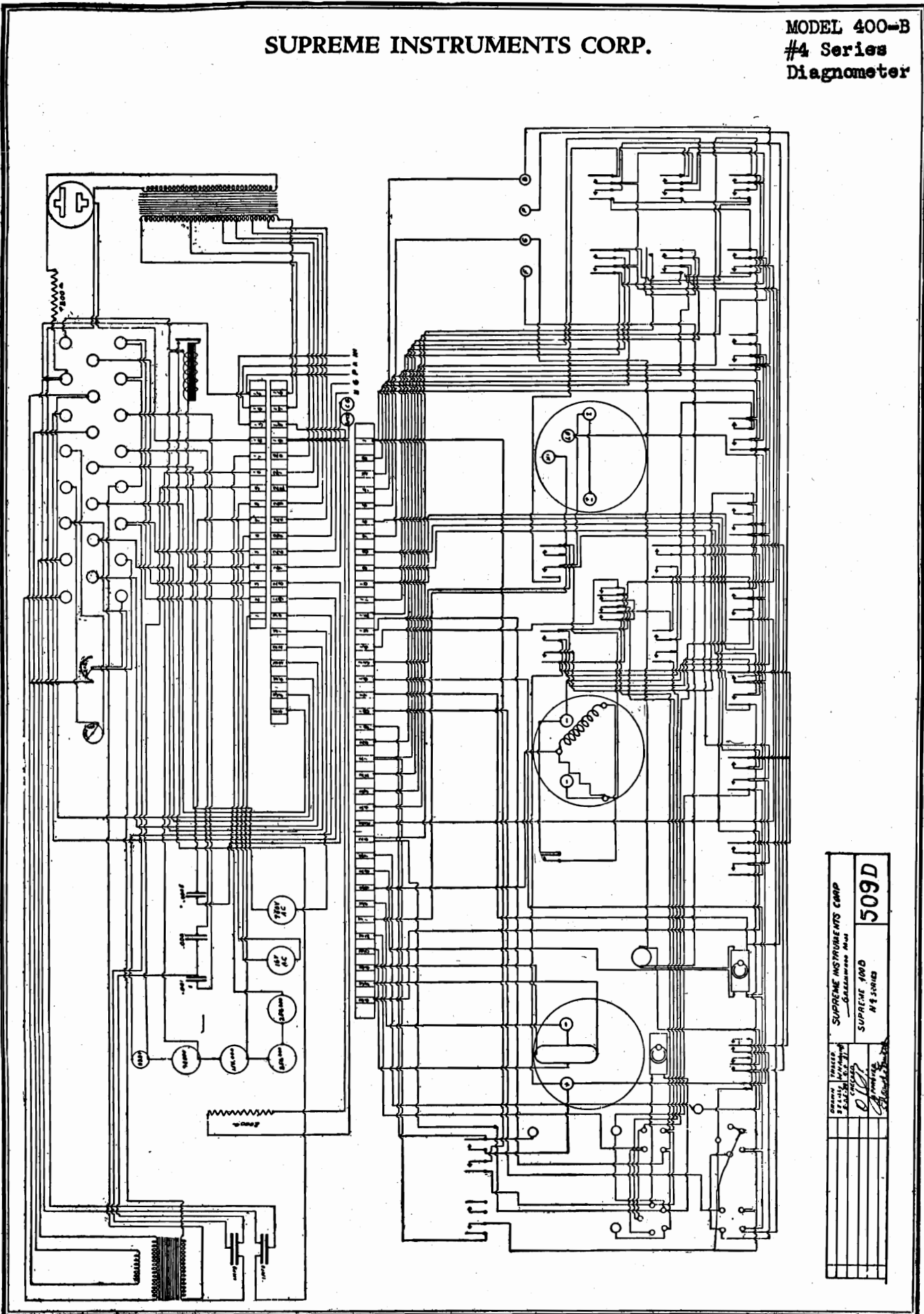

DRAWN BY E. J. [Signature]		SUPREME INSTRUMENTS CORP. GALLUP, N.M.	
CHECKED BY [Signature]		SUPREME 400-B #4 SERIES	
DATE [Blank]		509D	
REVISIONS		[Blank]	
[Blank]		[Blank]	
[Blank]		[Blank]	
[Blank]		[Blank]	
[Blank]		[Blank]	

SUPREME INSTRUMENTS CORP.

MODEL 56 Analyzer
Weston Metered
MODEL 90 Analyzer
Weston Metered 6-J

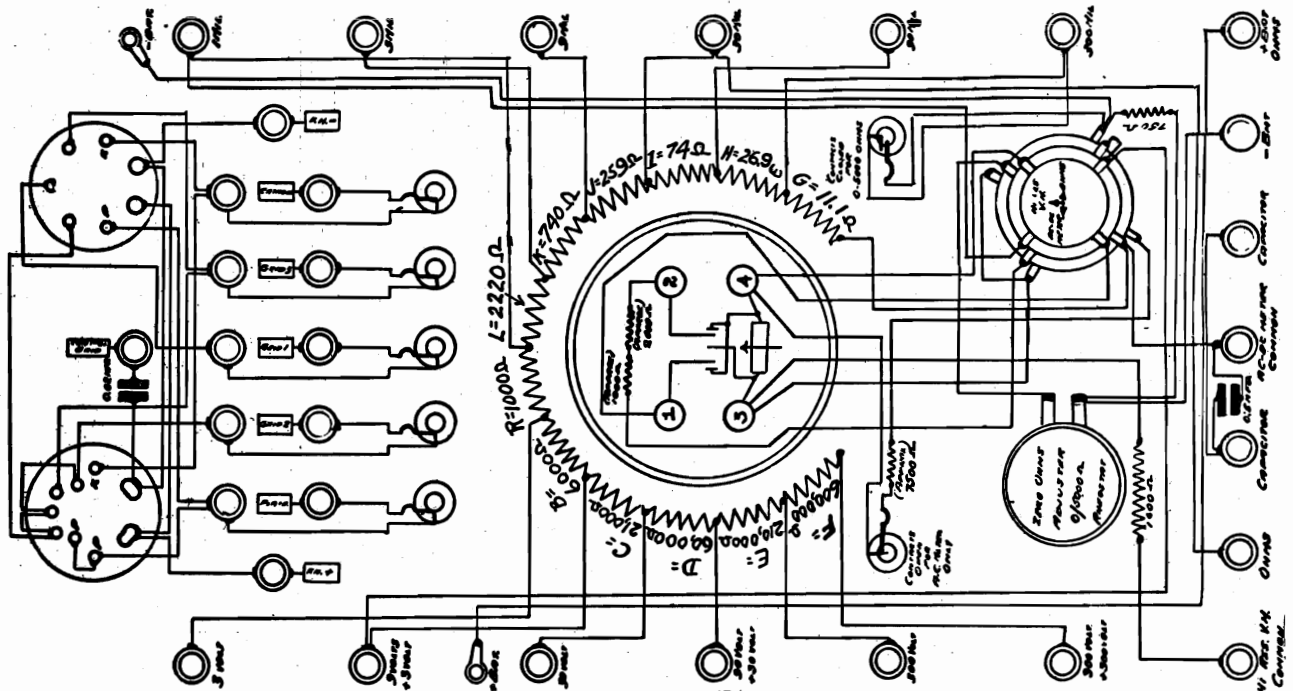

NOTE: The Flares Used in Enclosure Leads Through Armature Circle to Analyzer Base.

Checked	SUPREME INSTRUMENTS CORP GREENWOOD, MISS. POINT TO POINT DIAGRAM OF WESTON METERED MODEL 56 ANALYZER	Date: 4/1/52
Approved		639-B

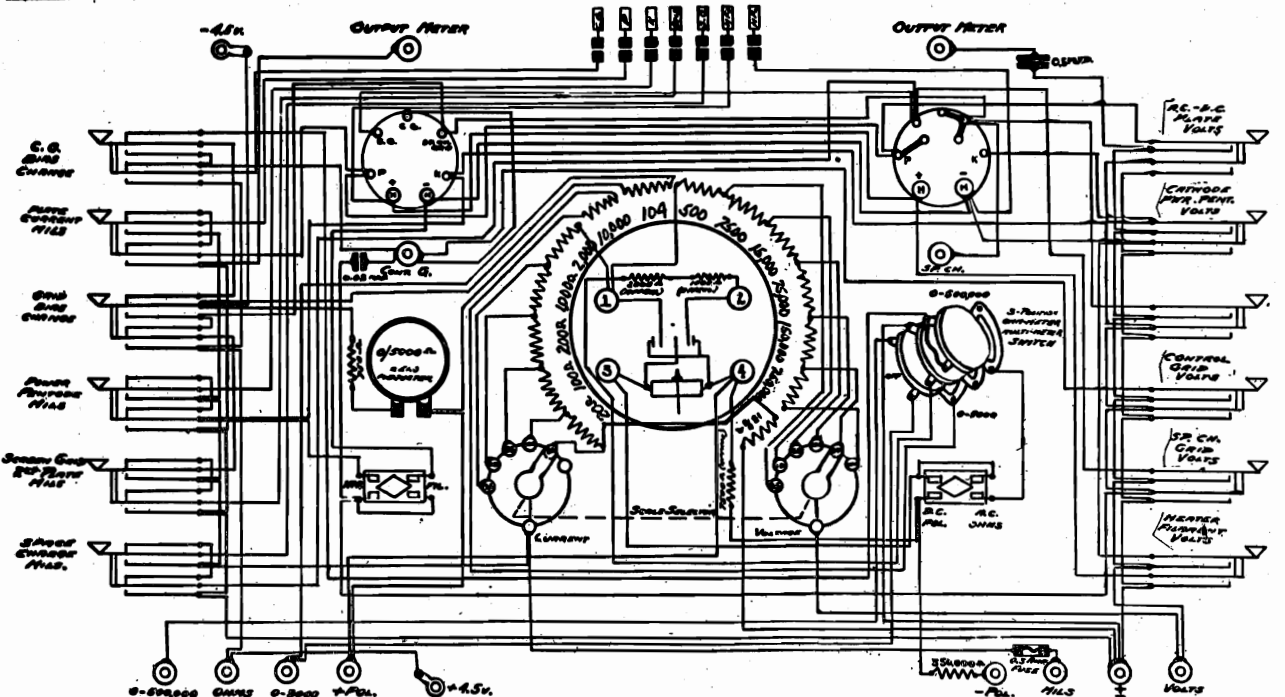

Checked	SUPREME INSTRUMENTS CORP GREENWOOD, MISS. POINT TO POINT DIAGRAM OF WESTON METERED MODEL 90 ANALYZER SERIES 6-J	Date: 4/1/52
Approved		641-B

MODEL 90 Analyzer
MODEL Output Meter

SUPREME INSTRUMENTS CORP.

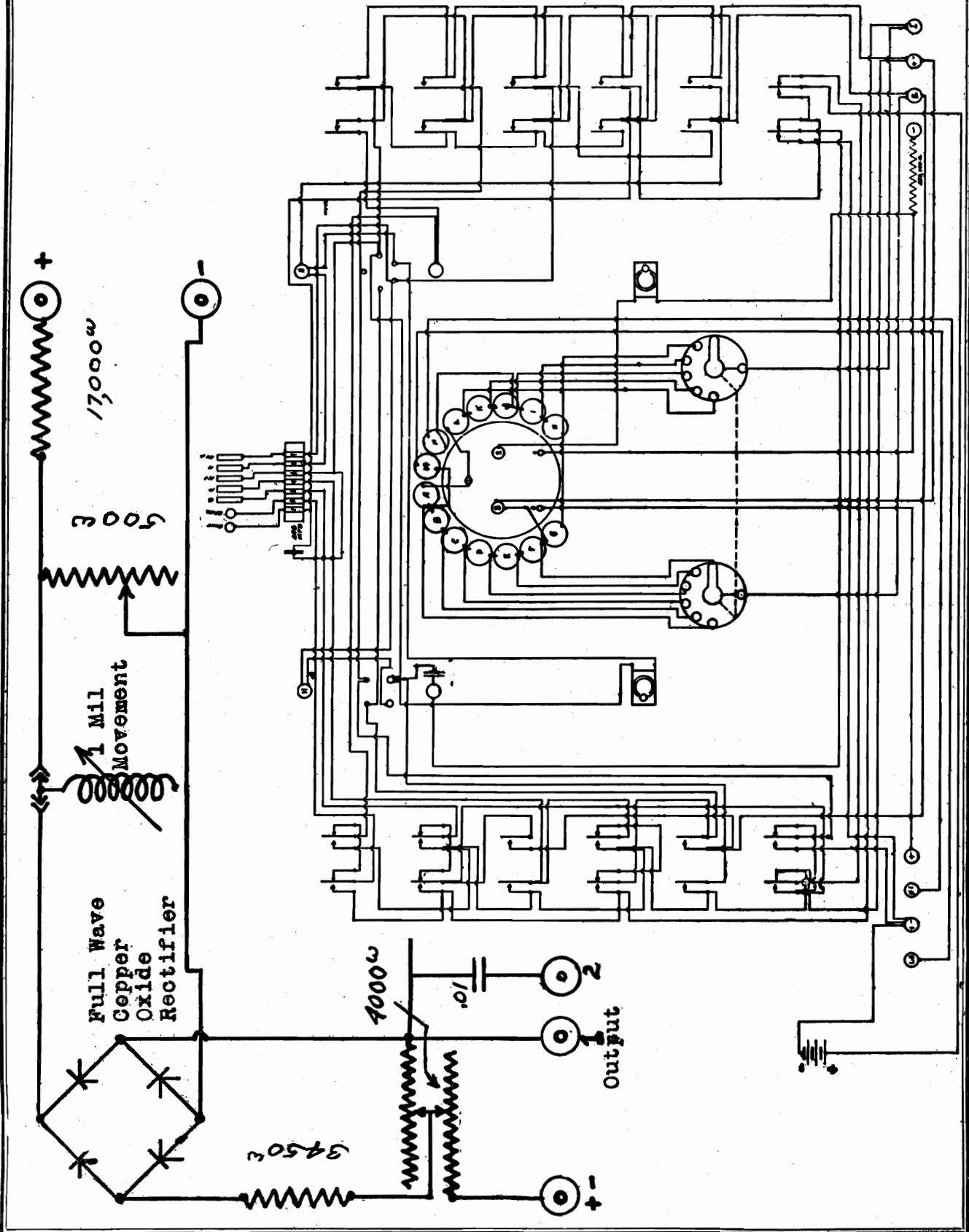

MODEL AC 84,85
Chassis Views
Speaker
MODEL AC 94,95
Speaker

TRANSFORMER CORP. OF AMERICA

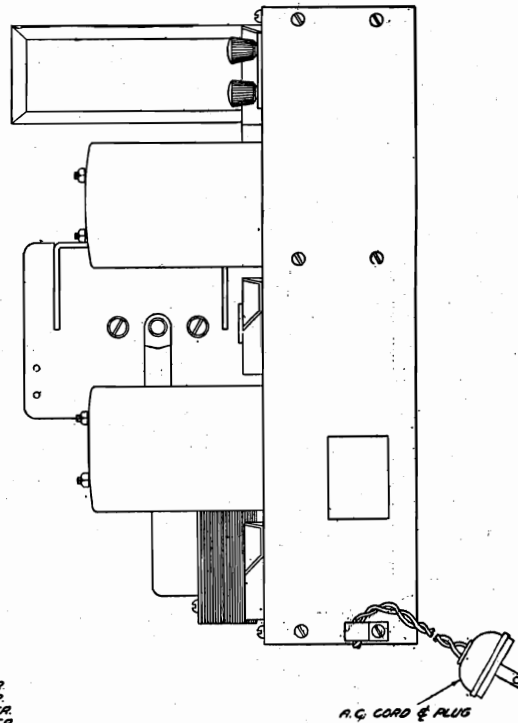
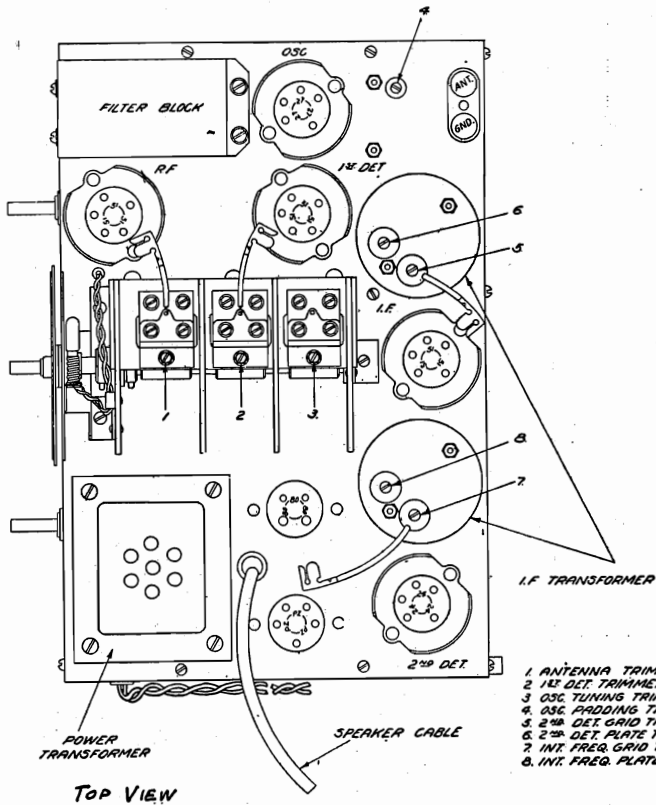

TOP VIEW

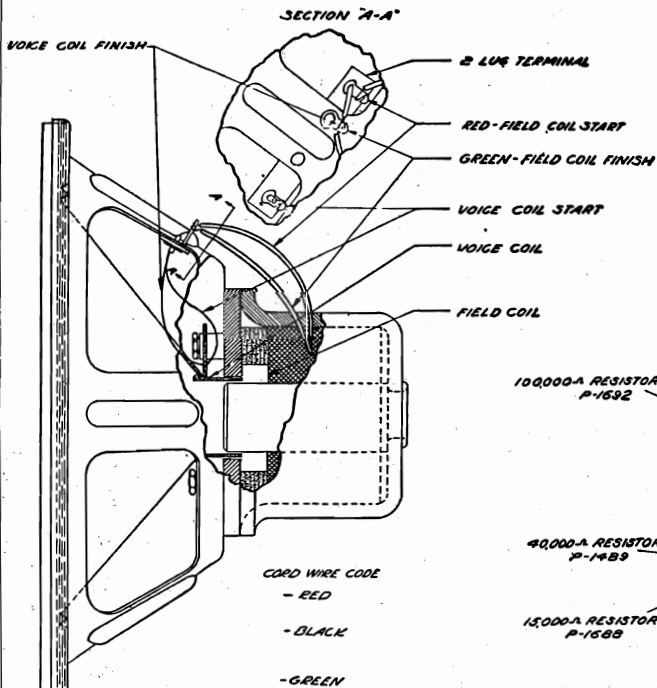

DYNAMIC SPEAKER
MODELS 84 & 85 AND 94 & 25-94

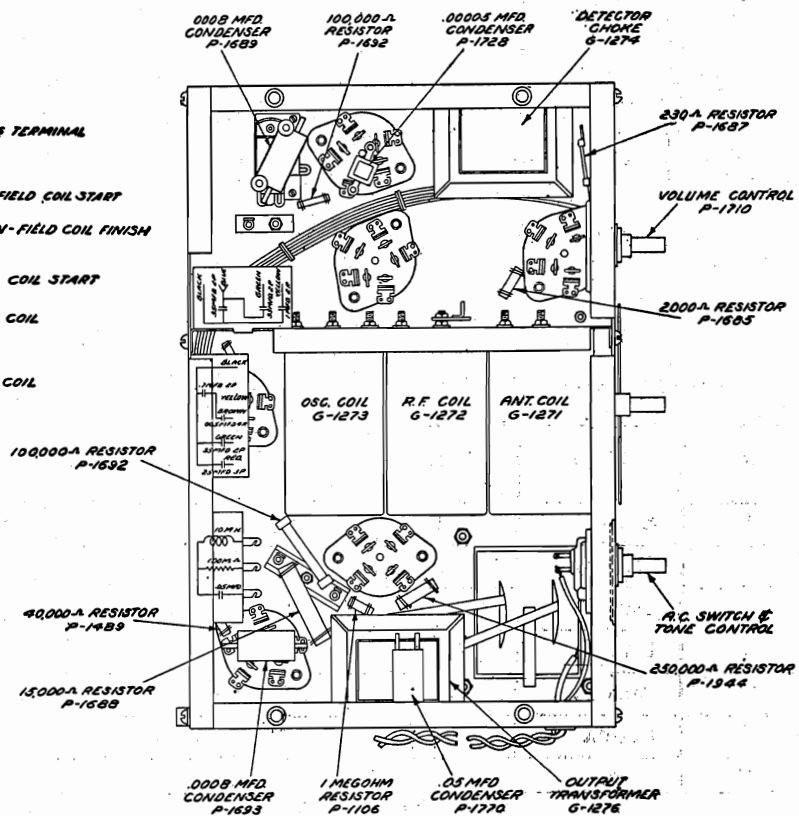

G-83 CHASSIS
BOTTOM VIEW

TRANSFORMER CORP. OF AMERICA

MODEL AC 84,85
 MODEL AC 94,95
 Alignment Data

CLARION

MODELS 84 & 85

MODELS 94 & 25-94

READJUSTING TRIMMERS

To readjust the trimmers on these super-heterodyne receivers it will be necessary that a good design of 175 k.c. oscillator be employed and that a dependable broadcast test oscillator be on hand so that stages handling intermediate frequency and those handling radio frequency can be thoroughly checked. It is advisable to use a bakelite screw driver when making any of these adjustments.

First, connect the 175 k.c. oscillator output leads from the control grid cap of the first detector tube to ground. Do not remove any of the tubes from the sockets, and it is not necessary to disconnect the grid cap clip from the first detector tube. Reset trimmers No. 5, No. 6, No. 7 and No. 8 for maximum output. While this test oscillator is working into the intermediate frequency stages, no adjustment of the tuning condenser on the receiver will have any effect, inasmuch as the intermediate frequency stage is fixed tuned.

If your test oscillator is properly designed, it will supply exactly 175 k.c., and when trimmers No. 5, No. 6, No. 7 and No. 8 are set and turned for maximum output, they will be correctly adjusted.

Next, disconnect the 175 k.c. test oscillator and connect to the antenna binding post of the receiver, the output lead from your broadcast test oscillator or tune in a broadcast signal around 1400 k.c., then reset trimmer No. 2 and No. 1, respectively, for maximum output. This adjustment will track the first detector and r. f. stages.

To check calibration of the receiver, whether it be high or low, trimmer No. 3 (oscillator) should be reset until a station of known high frequency is brought in at the correct dial marking with peak volume. If your broadcast test oscillator is accurately calibrated, it might be used in place of the broadcasting station signal. In this adjustment, a broadcast station or test oscillator signal at about 1400 k.c. should be chosen. The setting of the trimmer at 1400 k.c. is more critical than it would be at 600 k.c.

The next adjustment is important and not easily explained in writing, so pay close attention to the following instructions. We will now balance the oscillator to the r. f. and first detector stages.

Tune the external broadcast test oscillator and the receiver both to 600 k.c., then slowly increase or decrease the capacity of No. 4 (oscillator padding trimmer), at the same time and continuously tuning back and forth across the signal with the receiver tuning condenser gang. The output meter needle will now be swinging up and down in step with the variation in tuning. Watch the peak of this swinging closely and readjust No. 4 trimmer until the swinging needle reaches its highest peak.

Retune the receiver and broadcast test oscillator to 1400 k.c. and re-check trimmer No. 3 to make sure that the adjustment of No. 4 has not thrown the receiver out of calibration. If it has, then readjust No. 3 until the calibration is correct, (as previously explained), and check on trimmers No. 2 and No. 1, to make sure that the adjustment of No. 4 has not reduced the sensitivity.

CONTINUITY TESTS

(Applicable to completely and partially in-operative sets and circuits)

A 175 k.c. test oscillator should be connected to the grid cap of the first detector tube so that the modulated signal can be reproduced in the loud speaker. This indicates that the first detector and intermediate frequency stages are operating. To determine if the oscillator is working, a broadcast test oscillator should be connected to the grid cap of the first detector tube. No signal will come through unless the oscillator tube and stage are functioning correctly. The r. f. tube, of course, can be checked lastly by connecting the broadcast test oscillator to the antenna and ground binding posts of the receiver.

MODEL AC 84,85
Parts List
MODEL 120-139
Parts List

TRANSFORMER CORP. OF AMERICA

MODELS 84-85 (Also Series 120-139)

P-1038	Pilot lamp	.35	P-1931	10" diaphragm for G-1370 speaker	.75
P-1049	Grip cap clip	.05	P-1944	250,000 ohm resistor	.35
P-1096	A. C. cable clip	.05	P-1955	Tone cont. on-off switch	1.90
P-1106	1,000,000 ohm resistor	.35	P-1990	10" diaphragm for P-1883 speaker	.75
P-1354	Chassis mounting screws	2.50 C	P-1991	Voice coil and spider for P-1883 speaker	.65
P-1459	Tube shield base	.20	P-3050	8" diaphragm for G-1260 speaker	.55
P-1472	Tube shield	.10	G-3019	Voice coil and spider for G-1260 speaker	.65
P-1488	20,000 ohm resistor	.35	G-1220	Dial drive inc. pilot lamp socket	\$ 1.50
P-1499	40,000 ohm resistor	.30	G-1236	I. F. transformer	2.60
P-1593	24 socket	.20	G-1255	Power trans., 60 cycle	4.00
P-1595	80 socket	.20	G-1255A	Power trans., 25 cycle	5.85
P-1597	27 socket	.20	G-1255B	Power trans., 220 volt	5.85
P-1634	Ant. ground binding post	.25	†G-1260	8" Speaker for model 85	12.50
P-1637	Escutcheon plate	.55	G-1271	Antenna coil	1.25
P-1680	Osc. padding cond.	.45	G-1272	R. F. coil	1.25
P-1682	51 socket	.20	G-1273	Osc. coil	1.00
P-1683	47 socket	.20	G-1274	Filter choke	1.65
P-1685	2000 ohm resistor	.35	G-1276	Output transformer	2.00
P-1687	230 ohm resistor	.20	G-1277	Detector plate choke	1.50
P-1688	15,000 ohm resistor	.55	G-1350	Filter pack, 60 cycles	5.00
P-1689	.0008 mfd. cond., red dot	.30	G-1350A	Filter pack, 25 cycles	6.50
P-1692	100,000 ohm resistor, R. F.	.35	G-1351	R. F. bypass cond.	1.00
P-1693	.0008 mfd. condenser	.25	G-1352	A. F. bypass cond.	1.25
P-1700	Chassis mounting strap	.15	G-1357	Voice coil for G-1360 and G-1370 speakers	.65
P-1704	Knobs	.30	*G-1360	8" Speaker for model 85	12.50
P-1707	Escutcheon screws	.75 C	*G-1370	10" Speaker for model 84	12.50
P-1710	Volume control	1.75			
P-1728	.00005 mfd. condenser	.30			
P-1770	.05 tone control cond.	.25			
†P-1883	10" speaker for model 84	12.50			

*Speaker number stamped on field coil pot.
†Blank—no number stamped on field coil pot.

SERIES 120-139

P-4033	Escutcheon Plate (replacing P-1637)	\$0.55
P-4037	Large Knobs (replacing P-1704)	.30
P-4047	Small Knobs (replacing P-1704)	.25
P-4075	Tone Control (replacing P-1955)	1.90
P-4080	Volume Control (replacing P-1710)	1.75
G-1363	Oscillator Padding Condenser (replacing P-1680)	.75
G-1379	Dial and Scale Assembly (replacing G-1220)	1.50
G-1402	I. F. Transformer (replacing G-1236)	1.75

For complete parts data refer to parts list of models 84-85 above.

(Be Sure to Specify As Above if Ordering Speakers or Parts of Same)

MODEL AC 100 Series
 TRANSFORMER CORP. OF AMERICA Schematic - Voltage

CLARION SERIES 100 SUPERHETERODYNE

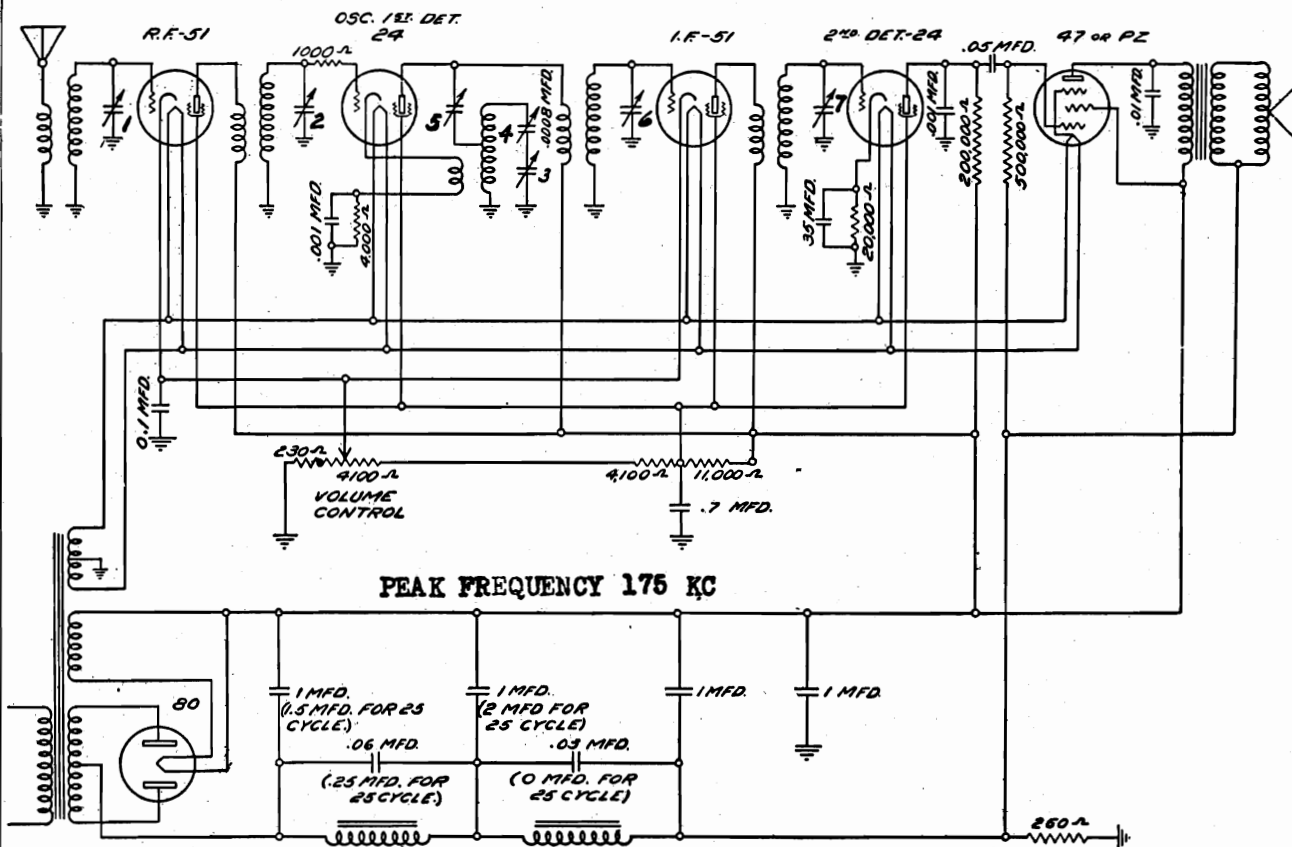

PEAK FREQUENCY 175 KC

Model AC-100, 25-100 (1931)

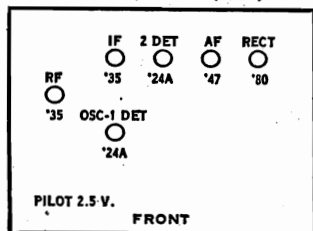

SCHEMATIC DIAGRAM
 FOR
 CLARION
 MODEL -100

READING TAKEN WITH WESTON MODEL 565 ANALYZER

MODEL No.		CUSTOMER			BY			
No.	Stage	Type Tube	"A" Volts	"B" Volts	Cont. Grid Volt	Cath. Volts	S. G. Volts	I _p Norm.
1	R. F.	51	2.15	235	2.4	2.5	80.	5.0
2	Autodyne	24	2.15	225	5.0	6.0	75.	3.0
3	I. F.	51	2.15	230	2.4	2.5	75.	4.0
4	2nd Det.	24	2.15	104	10.	15.	65.	0.6
5	Audio	47	2.25	250	16	0	260	30.
6	Rect.	80	4.4					57.5

Line Voltage 115. Order of Test: 1 Rect., 2 Power, 3 Det., Etc.
 Volume Control Position, Full On.

NOTE: Since resistance tolerances in the sets are plus or minus 10% and tubes may vary over 20%, your readings may disagree with the above by plus or minus 30%.

MODEL AC 100 Series
 Chassis View
 Data

TRANSFORMER CORP. OF AMERICA

CLARION SERIES 100 SUPERHETERODYNE

DIAPHRAGM
 P-3050-8"
 P-1931-10"

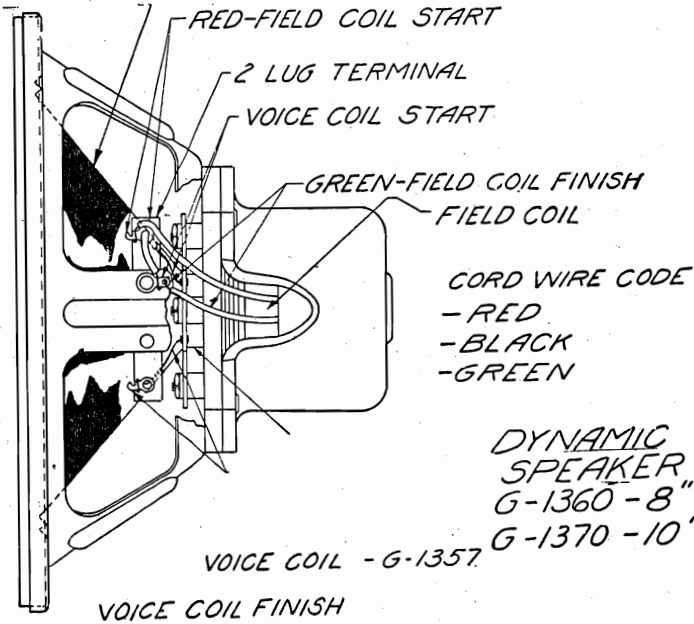

CONTINUITY TESTS

Applicable to Completely and Partially In-Operative Sets and Circuits)

To determine which section of the receiver is defective, the second detector tube might be tapped with the finger, listening for a ringing noise in the speaker—this indicates that the audio end is O. K. A 175 K. C. test oscillator should be connected to the grid cap of the Super-autodyne tube so that the modulated signal can be reproduced in the loud speaker. This indicates that the Super-autodyne and intermediate frequency stages are operating. To determine if the super-autodyne is oscillating as it should be, a broadcast test oscillator should be connected to the grid cap of the super-autodyne tube. No signal will come through unless the tube is oscillating, and the stage functioning correctly. The R. F. tube, of course, can be checked, lastly by connecting the broadcast test oscillator to the antenna and ground binding posts of the receiver.

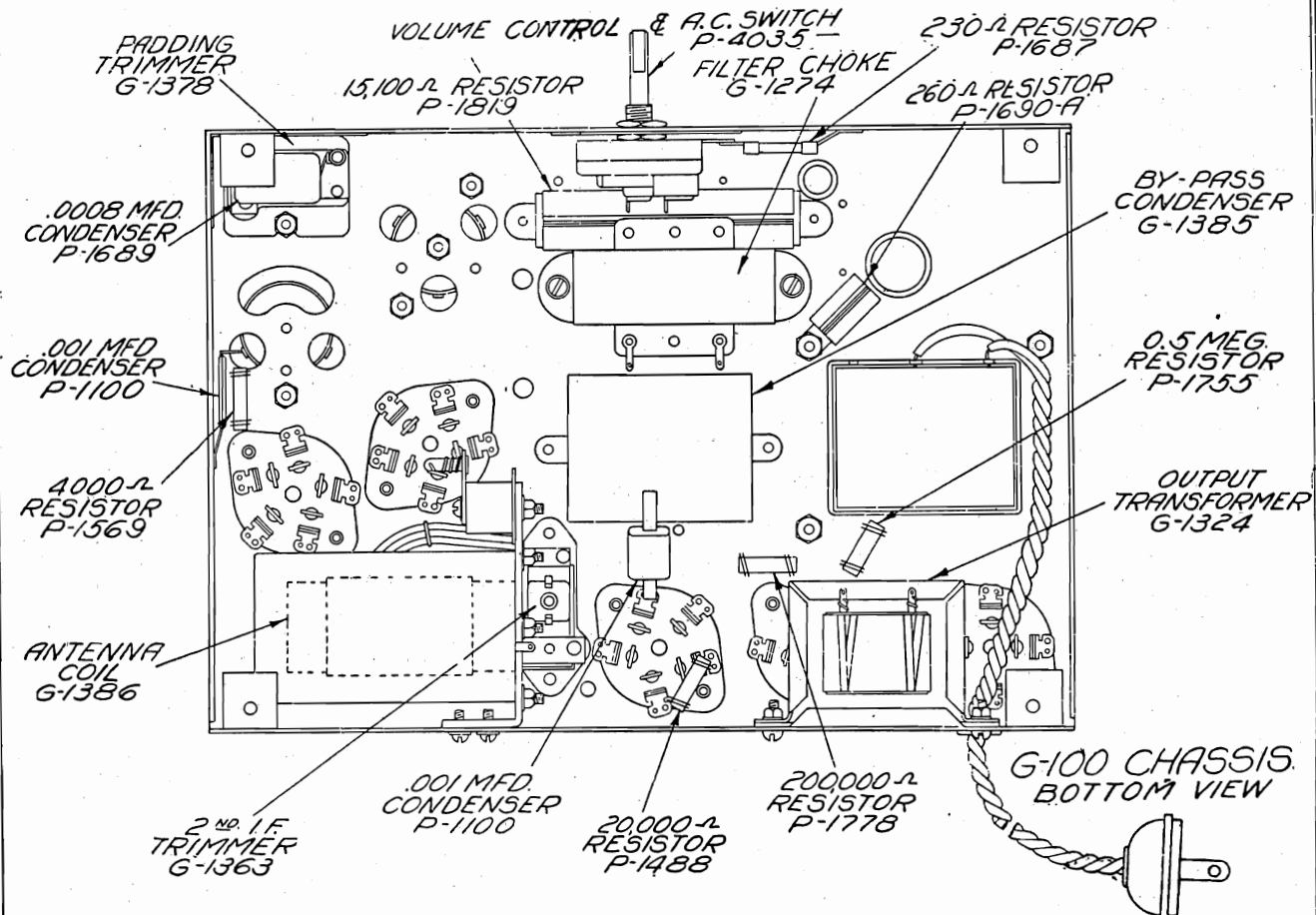

MODEL AC 100 Series
Trimmer Notes

TRANSFORMER CORP. OF AMERICA

CLARION SERIES 100 SUPERHETERODYNE

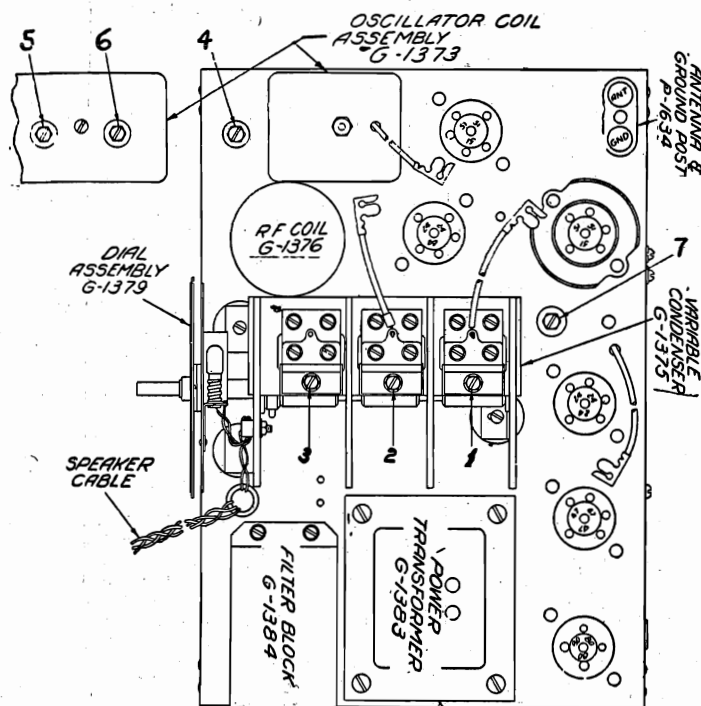

frequency stages, no adjustment of the tuning condenser on the receiver will have any effect, inasmuch as the intermediate frequency stage is fixed tuned.

If your test oscillator is properly designed, it will supply exactly 175 k. c., and when trimmers number 5, 6 and 7 are set for maximum output, they will be correctly adjusted and should be sealed.

Next, disconnect the 175 k. c. test oscillator and connect to the antenna binding post of the receiver, the output lead from your broadcast test oscillator, or tune in a broadcast signal around 1400 k. c., then reset trimmers numbers 2 and 1 respectively for maximum output. This adjustment will track the super-autodyne grid circuit of the R. F. stage.

To check the calibration of the receiver, whether it be high or low, trimmer number 3 should be reset until a station of known high frequency is brought in on the correct dial marking with peak volume. If your broadcast test oscillator is accurately calibrated, it might be used in place of the broadcasting station signal. In this adjustment, a broadcast station or test oscillator signal at about 1400 k. c. should be chosen. The setting of the trimmer at 1400 k. c. is more critical than it would be at 600 k. c.; calibration, therefore more accurate.

The next adjustment is important and not easily explained in writing, so pay close attention to the following instruction. We will now balance the oscillator to the r. f. and first detector stages.

Tune the external broadcast test oscillator and the receiver both to 600 k.c., then slowly increase or decrease the capacity of No. 4 (oscillator padding trimmer), at the same time and continuously tuning back and forth across the signal with the receiver tuning condenser gang. The output meter needle will now be swinging up and down in step with the variation in tuning. Watch the peak of this swinging closely and readjust No. 4 trimmer until the swinging needle reaches its highest peak.

Retune the receiver and broadcast test oscillator to 1400 k.c. and re-check trimmer No. 3 to make sure that the adjustment of No. 4 has not thrown the receiver out of calibration. If it has, then readjust No. 3 until the calibration is correct, (as previously explained), and check on trimmers No. 2 and No. 1, to make sure that the adjustment of No. 4 has not reduced the sensitivity.

READJUSTING TRIMMERS

Number 1 is the antenna trimmer.

Number 2 is the gang condenser trimmer tuning the grid of the Super-autodyne.

Number 3 is the gang condenser trimmer tuning the plate (or oscillator of the super-autodyne).

Number 4 is the oscillator padding trimmer.

Number 5 is the Super-autodyne plate trimmer.

Number 6 is the I. F. grid trimmer.

Number 7 is the second detector grid trimmer.

To readjust the trimmer, it will be necessary that a good design of 175 k. c. oscillator be employed, and that a dependable broadcast test oscillator be on hand so that stages handling intermediate frequency, and those handling radio frequency can be thoroughly checked. It is advisable to use a bakelite screwdriver when making any of these adjustments.

First, connect the 175 k. c. oscillator output leads from the control grid cap of the super-autodyne tube to ground. Do not remove any of the tubes from the sockets, and it is not necessary to disconnect the grid cap clip from the tube. Reset trimmers numbers 5, 6 and 7 for maximum output. While this test oscillator is working into the intermediate fre-

MODEL AC 100 Series
Parts List
Continuity Test

TRANSFORMER CORP. OF AMERICA

CONTINUITY TEST TABLES

Using 10 Volt Scale 1000 Ohm Per Volt Meter and 4 1/2 Volt Battery

Circuit Tested	From	To	Readings
R. F. Grid	Rect. Fil. Prong	R. F. Grid Clip	1.5
R. F. Screen	Rect. Fil. Prong	R. F. Screen Prong	2.2
R. F. Plate	Rect. Fil. Prong	R. F. Plate Prong	4.4
R. F. Cathode	Rect. Fil. Prong	R. F. Cathode Prong	1.5
Autodyne Grid	Rect. Fil. Prong	Autodyne Grid Clip	1.5
Autodyne Screen	Rect. Fil. Prong	Autodyne Screen Prg.	2.2
Autodyne Plate	Rect. Fil. Prong	Autodyne Plate Prg.	4.5
Autodyne Cathode	Rect. Fil. Prong	Autodyne Cath. Prg.	1.3
I. F. Grid	Rect. Fil. Prong	I. F. Grid Clip	1.5
I. F. Screen	Rect. Fil. Prong	I. F. Screen Prong	2.2
I. F. Plate	Rect. Fil. Prong	I. F. Plate Prong	4.4
I. F. Cathode	Rect. Fil. Prong	I. F. Cathode Prong	1.5
2nd Det. Grid	Rect. Fil. Prong	2nd Det. Grid Clip	1.5
2nd Det. Screen	Rect. Fil. Prong	2nd Det. Screen Prg.	2.2
2nd Det. Plate	Rect. Fil. Prong	2nd Det. Plate Prong	.2
2nd Det. Cathode	Rect. Fil. Prong	2nd Det. Cath. Prong	.8
Pent. Cont. Grid	Rect. Fil. Prong	Pent. C. G. Prong	.1
Pent. Plate	Rect. Fil. Prong	Pent. Plate Prong	4.4
Pent. S. C. Grid	Rect. Fil. Prong	Pent. S. C. Grid Prg.	4.5
Ant. Pri.	Antenna Post	Grid. Post	4.5
Pwr. Trans. Pri.	Across	A. C. Plug	4.5
Pwr. Trans. Sec.	Across	Rect. Plates	4.3
Spkr. Field	Red Lead-Cable	Black Lead Cable	4.2
Spkr. V. C.	Green Lead Cable	Black Lead Cable	4.5

P-1038	Dial light	\$ 0.35	P-4045	I. F. coil (unshielded)	.60
P-1049	Grid cap clip	.05	P-4047	Small knobs	.25
P-1100	Autodyne Cath. cond. .008	.25	P-4088	2nd det. cathode Resistor 20,000 ohms	.25
P-1459	Tube shield base	.10	G-1274	Filter choke	1.75
P-1472	Tube shield	.10	G-1324	Output transformer	1.50
P-1569	Autodyne Cath. resistor 4000 ohms	.55	G-1357	Voice coil and spider as- sembly	.75
P-1593	Type 24 socket	.20	G-1360	Speaker complete	12.50
P-1595	Type 80 socket	.20	G-1363	Trimmer condenser	.45
P-1634	Ant. ground binding post	.25	G-1372	Antenna and R. F. coil shield	.25
P-1682	Type 51 socket	.20	G-1373	Autodyne coil	2.00
P-1683	Type 47 socket	.20	G-1376	R. F. coil, less shield	.75
P-1689	Autodyne trimmer cond. .008	.30	G-1378	Autodyne trimmer cond. (in- sulated)	.50
P-1690A	260 ohm wire wound resistor	.25	G-1379	Dial and scale assembly	1.50
P-1755	Pentode cont. grid resistor, 500,000 ohms	.35	G-1383	Power transformer 110 v. 60 cycle	3.50
P-1778	2nd det. plate resistor, 200,000 ohms	.30	G-1383A	Power transformer 110 v. 25 cycle	7.20
P-1819	Voltage dividing resistor	.75	G-1383B	Power transformer 220 v. 60 cycle	7.20
P-3050	Speaker diaphragm	.55	G-1384	Filter pack, 60 cycle	3.50
P-4033	Escutcheon plate	.55	G-1384A	Filter pack, 25 cycle	4.50
P-4035	Vol. cont. and on-off switch	2.00	G-1385	By-pass condenser pack	1.50
P-4037	Large knobs	.30	G-1386	Antenna coil	.75

TRANSFORMER CORP. OF AMERICA

MODEL AC 240
Schematic
Chassis View
Breakdown
Parts List

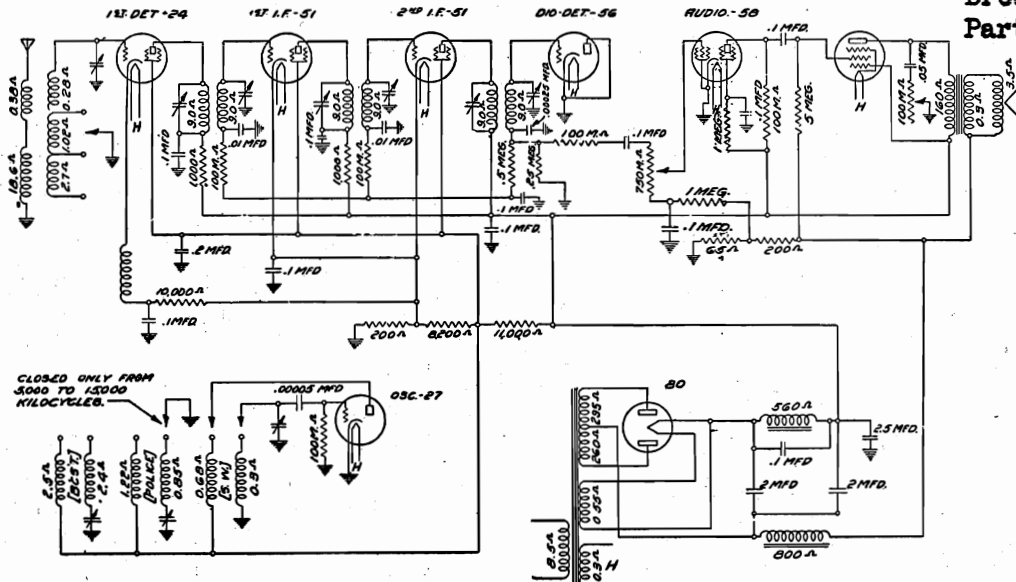

IF PEAK 490 KC

SCHEMATIC DIAGRAM
OF
CLARION MODEL 240
DRAWN BY L.J. CHECKED BY [Signature]
APPROVED BY [Signature] DATE: 5-17-32

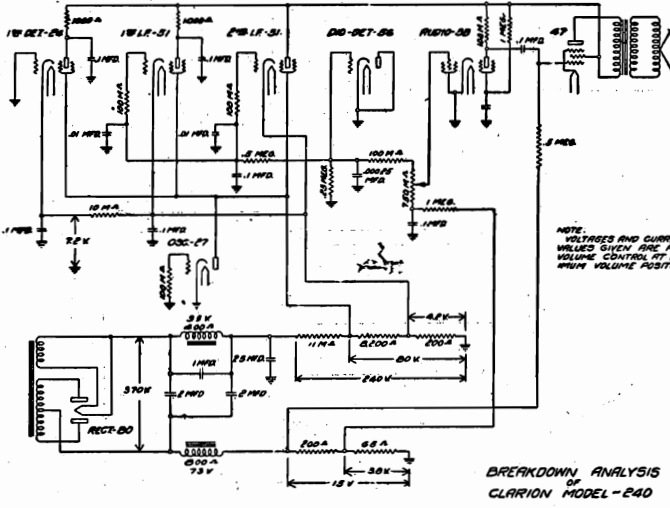

BREAKDOWN ANALYSIS
OF
CLARION MODEL-240

P-1038	Pilot lamp	\$.35
P-1049	Grid cap clip05
P-1106	1 megohm resistor35
P-1118	Chassis mounting washers03
P-1472	Tube shields10
P-1518	Chassis mounting screws05
P-1593	Type 24 socket20
P-1595	" 80 "20
P-1597	" 27 "20
P-1682	" 51 "20
P-1683	" 47 "20
P-1692	100,000 ohm resistor35
P-1728	.00005 mfd cond30
P-1755	500,000 ohm resistor35
P-4037	Knobs (large)30
P-4047	" (small)25
P-4118	1,000 ohm resistor20
P-4216	Speaker diaphragm50
P-4229	Ant. gnd building post15
P-4247	Band switch	2.50
P-4256	Escutcheon plate55
P-4259	Tone control-on-off switch	1.75
P-4260	Volume control	1.00
P-4262	Type 56 socket20
P-4264	" 58 "20
P-4267	Voltage div. resistor90
P-4271	10,000 ohm resistor20

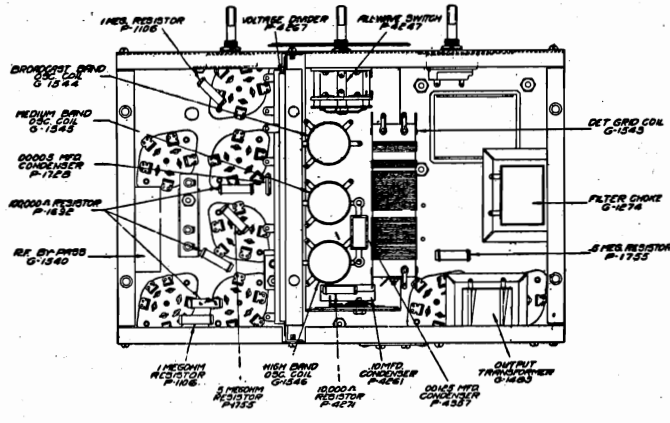

G-240 CHASSIS
BOTTOM VIEW

G-1274	Filter choke	1.75
G-1364	Trimmer and bracket assembly75
G-1483	Output transformer	1.50
G-1484	Speaker voice coil40
G-1502	Speaker complete	5.00
G-1528	Power transformer 110 vo.60 cy.	3.75
G-1528A	" " 110 " 25 "	5.25
G-1528B	" " 220 " 60 "	4.50
G-1529	Filt. pack " 110 " 60 "	3.50
G-1529A	" " 110 " 25 "	4.50
G-1530	Dial and scale assembly	1.50
G-1531	First I. F. transformer	2.50
G-1532	Second "	2.50
G-1533	Third "	2.50
G-1540	Bypass cond. assembly	1.75
G-1543	Antenna coil	1.75
G-1544	Broadcast osc. coil	1.25
G-1545	Medium osc. coil	1.25
G-1546	High frequency osc. coil	1.25

Full List Prices - Your Regular Discount Applies

UNITED AMERICAN BOSCH CORP.

MODEL 20-J, 20-K,
20-L
Schematic, Voltage

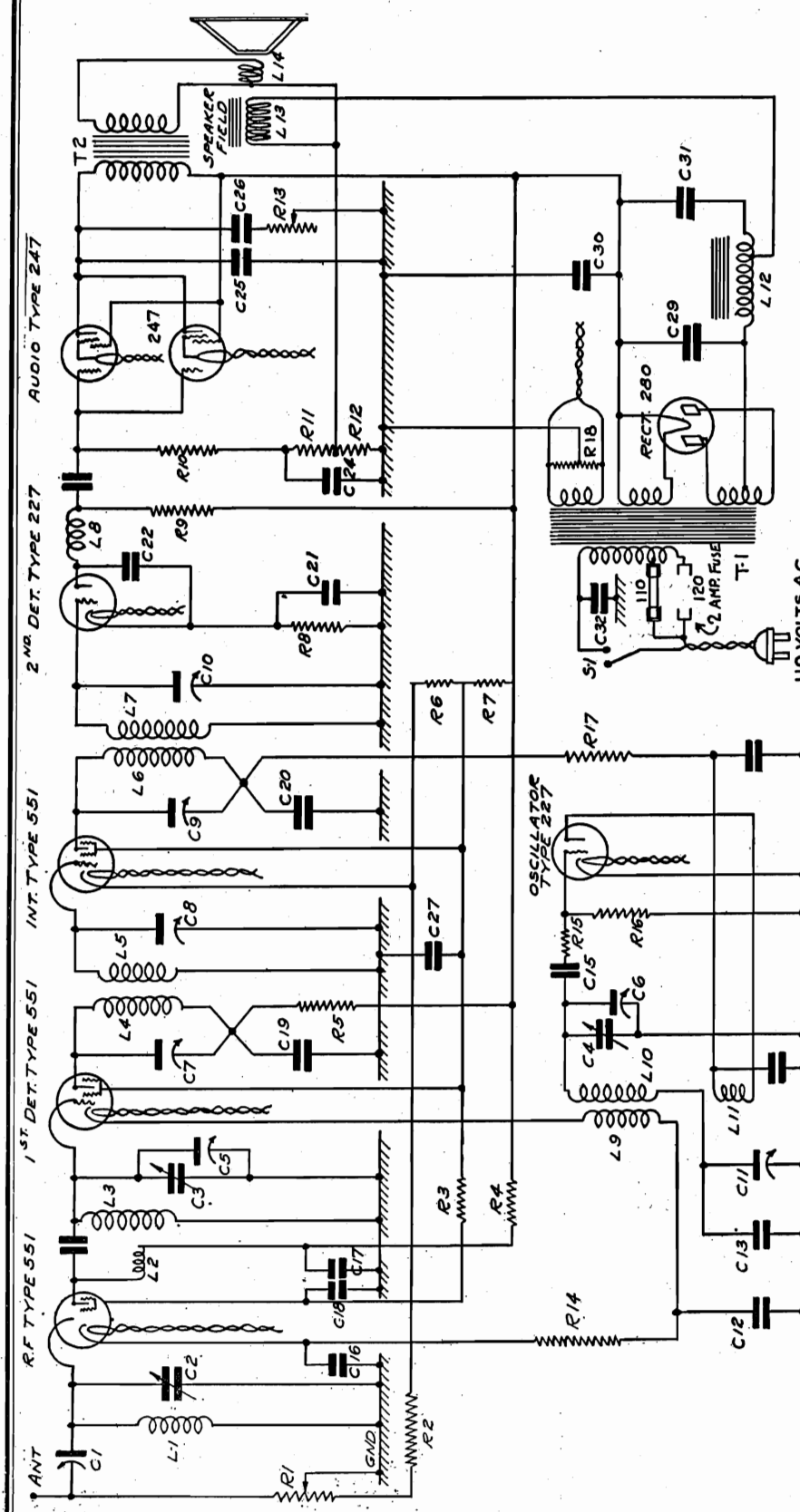

IF PEAK 175 KC

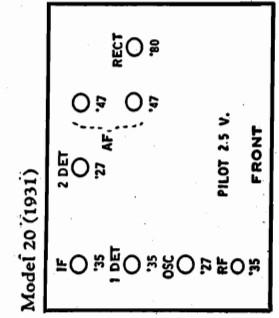

Stage	Tube	Plate	Screen	Cathode	Grid	Fil.	Plate	Current
RF	551	225	90	18	3	2.2	3.5	MA
Oscillator	227	60	0	0	2.2	5	MA
1st Det.	551	225	80	8	7	2.2	2	MA
I.F.	551	240	80	4	3	2.2	4	MA
2nd Det.	227	130	0	15	2.2	1	MA
Audio	247	240	240	16	2.2	30	MA
Audio	247	240	240	16	2.2	30	MA
Rectifier	280	5	38	MA

MODEL 20-J, 20-K,
20-L
Electrical Values
Notes

UNITED AMERICAN BOSCH CORP.

Antenna Adjustment—The antenna adjustment must be made when any change is made in the antenna.

Alignment Instruction

1. Connect the 175 KC output of the oscillator to the grid cap of the 1st detector.
 - a—Align Primary of 2nd IF Transformer (C9).
 - b—Align Secondary of 2nd IF Transformer (C10).
 - c—Align Primary of 1st IF Transformer (C7).
 - d—Align Secondary of 1st IF Transformer (C8).

(It is advisable to go over these adjustments twice to insure accuracy).

2. Reset the Oscillator for 1400 KC, connected to the 1st detector grid as before.
 - a—Align the Oscillator tuning condenser C6 by unscrewing two full turns, then turning slowly to the right until the first peak is reached.
3. Connect the 1400 KC output to the Antenna Connection of the set.
 - a—Align Antenna Trimmer and 1st detector C3.

- C 1—Antenna Trimmer
- C 2
- C 3
- C 4 } Tuning Condenser Gang with
- C 5 } trimmer condensers
- C 6
- C 7 } Variable Condenser Unit 75 to 140 mmf.
- C 8 }
- C 9 }
- C 10 } Variable Condenser Unit 75 to 140 mmf.
- C 11—Oscillator Series Trimming Condenser
- C 12—By-pass Condenser—.05 mfd.
- C 13—Oscillator Series Tuning Condenser .0011 mfd.
- C 14—Oscillator Plate By-pass Condenser .05 mfd.
- C 15—Oscillator Grid Condenser .0001 mfd.
- C 16—RF Cathode By-pass Condenser .05 mfd.
- C 17—RF Screen By-pass Condenser .05 mfd.
- C 18—RF Plate By-pass Condenser .05 mfd.
- C 19—1st Detector Blocking Condenser .05 mfd.
- C 20—IF Blocking Condenser .05 mfd.
- C 21—Detector Cathode By-pass Condenser .25 mfd.
- C 22—Detector Plate By-pass Condenser .0011 mfd.
- C 23—Audio Coupling Condenser .05 mfd.
- C 24—Audio Grid By-pass Condenser .05 mfd.
- C 25—Audio Plate By-pass Condenser .02 mfd.
- C 26—Tone Selector Condenser .1 mfd.
- C 27—Screen By-pass Condenser .5 mfd.
- C 28—Oscillator By-pass Condenser .5 mfd.
- C 29—Filter Condenser 1.8 mfd.
- C 30—Filter Condenser 3.5 mfd.
- C 31—Filter Condenser 1.8 mfd.
- C 32—Buffer Condenser .05 mfd.

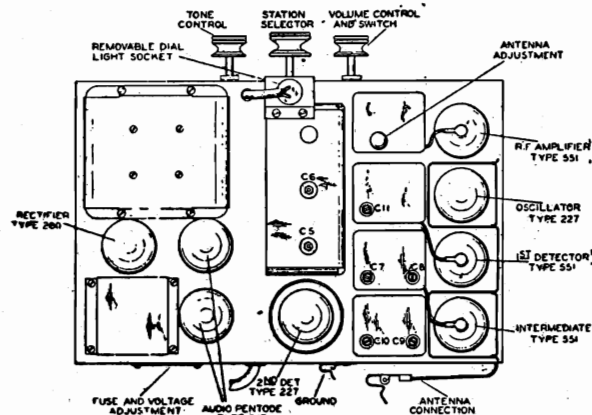

Alignment Adjustments

4. Retune the receiver to 600 KC and set oscillator to this frequency.
 - a—Align the oscillator low frequency adjustment C11. Rotate the dial slowly back and forth over a range of perhaps 1/4", at the same time rotating C11 back and forth until the maximum output is reached.
5. Return to 1400 KC (Receiver and Oscillator).
 - a—Re-align C3, C6 and the Antenna Trimmer.

- R 1—Volume Control 10,000 ohms
- R 2—Series Resistor 200 ohms
- R 3—RF Screen Resistor 1000 ohms
- R 4—RF Plate Resistor 1000 ohms
- R 5—1st Detector Plate Resistor 1000 ohms
- R 6—Divider Resistor 20,000 ohms
- R 7—Screen Supply Resistor 25,000 ohms
- R 8—2nd Detector Cathode Resistor 15,000 ohms
- R 9—2nd Detector Plate Resistor 100,000 ohms
- R 10—Audio Grid Resistor 250,000 ohms
- R 11—Audio Grid Resistor 100,000 ohms
- R 12—Audio Bias Resistor 200 ohms
- R 13—Tone Control
- R 14—Cathode Resistor 2000 ohms
- R 15—Oscillator Grid Resistor 5000 ohms
- R 16—Oscillator Grid Resistor 100,000 ohms
- R 17—Oscillator Plate Resistor 40,000 ohms
- T 1—Main Power Transformer
- T 2—Output Transformer
- S 1—Main Switch.
- L 1—Antenna Coil
- L 2—Primary of RF Coil
- L 3—Secondary of RF Coil
- L 4—I.F. primary coil
- L 5—I.F. secondary coil
- L 6—I.F. primary coil
- L 7—I.F. secondary coil
- L 8—Detector plate choke
- L 9—Oscillator coupling coil
- L 10—Oscillator grid coil
- L 11—Oscillator plate coil
- L 12—Filter choke coil
- L 13—Speaker Field Coil
- L 14—Speaker Voice Coil

UNITED AMERICAN BOSCH CORP.

MODEL 31,32
Schematic
Data - Socket

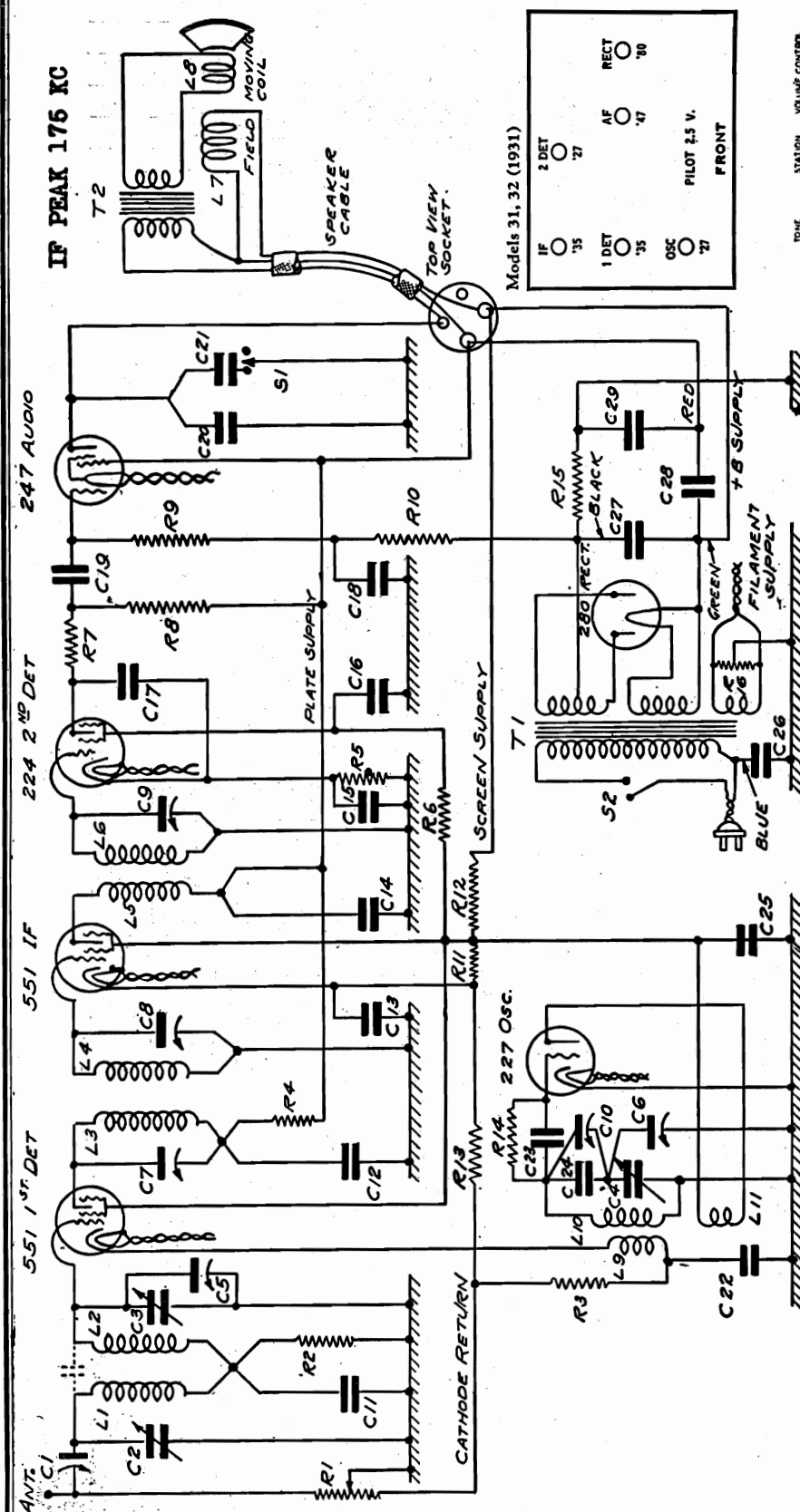

IF PEAK 176 KC

Models 31, 32 (1931)

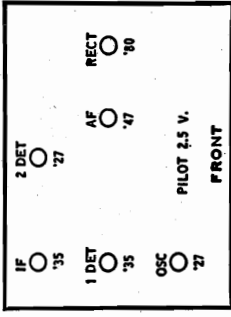

Antenna Adjustment—The antenna knob, located as shown on the drawing (figure 1) is for the purpose of obtaining the most efficient adjustment of the receiver to the antenna. Simply tune in a semi-distant broadcast station at reduced volume and turn the adjustment knob until the point of loudest reception is found. Select if possible a station received near 140 on the dial. The adjustment is permanent, and need not be disturbed unless the antenna is changed.

Line Voltage—The model 31 receiver is designed for use on 50 to 60 cycle alternating current, 105 to 120 volts. The model 32 is designed for 25 to 50 cycle, 105 to 120 volt alternating current. If excessive line voltage is encountered, some type of series resistance or "voltage regulator" should be employed.

Tone Control—The tone is varied from treble to bass by means of a two-position snap switch operated by the right hand knob. The range of motion of this switch has been reduced from that found on previous models, and care should be taken not to force the switch beyond the stop position.

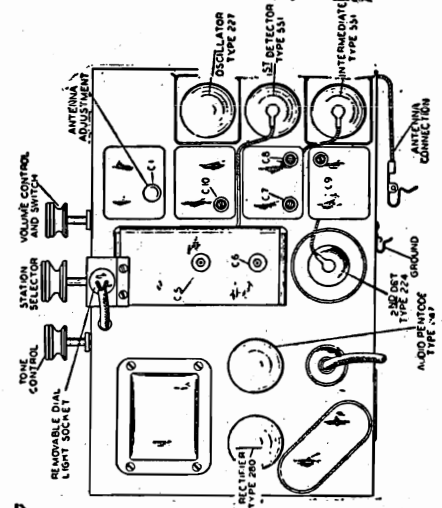

Top View of Model 31 Chassis

MODELS 31-32 Superheterodyne

MODEL 31,32 AC
Electrical Values
Voltage

UNITED AMERICAN BOSCH CORP.

SOCKET VOLTAGES

Stage	Tube	Plate	Screen	Cathode*	Grid	Fil	Plate MA
1st Det.	551	260	80	10	7	2.2	2
Oscillator	227	75	..	*0	*0	2.2	5
I.F.	551	260	80	3	3	2.2	4
2nd Det.	224	50	*5	3	1	2.2	*.1
Audio	247	250	250	..	*3	2.2	32
Rectifier	280					4.8	22-22

- T1—Power Transformer
- T2—Output Transformer
- L1—RF Coil
- L2—RF Coil
- L3—I.F. Coil (Primary)
- L4—I.F. Coil (Secondary)
- L5—I.F. Coil (Primary)
- L6—I.F. Coil (Secondary)
- L7—Speaker Field
- L8—Speaker Voice Coil
- L9—Oscillator Coupling Coil
- L10—Oscillator Grid Coil
- L11—Oscillator Plate Coil

Line voltage—115 volts

Volume control fully "on"

* These values will vary considerably with the type of test kit employed, due to the high resistance in the circuit.

- R1—Volume Control—10,000 ohms
- R2—Coupling Resistor—1000 ohms
- R3—1st Det. Cathode Resistor 5000 ohms
- R4—1st Det. Plate Resistor 1000 ohms
- R5—2nd Det. Cathode Resistor—50,000 ohms
- R6—2nd Det. Screen Resistor—2 megohms
- R7—2nd Det. Plate Resistor—10,000 ohms
- R8—2nd Det. Plate Resistor—1 megohm
- R9—Audio Grid Resistor—1/2 megohm
- R10—Audio Grid Resistor—100,000 ohms
- R11—Divider Resistor—20,000 ohms
- R12—Screen Supply Resistor—30,000 ohms
- R13—Cathode Resistor—300 ohms
- R14—Oscillator Grid Resistor—100,000 ohms
- R15—Audb Bias Resistor—350 ohms
- R16—Mid Tap Resistor
- C1—Antenna Trimmer
- C2—Tuning Condenser
- C3—Tuning Condenser
- C4—Oscillator Tuning Condenser
- C5—Alignment Condenser
- C6—Oscillator Tuning Alignment
- C7—I. F. Alignment Condenser
- C8—I. F. Alignment Condenser
- C9—Alignment Condenser
- C10—Oscillator Alignment
- C11—RF Coupling Condenser .05 mfd.
- C12—1st Det. Plate By-pass .05 mfd.
- C13—I. F. Cathode By-pass .05 mfd.
- C14—I. F. Plate By-pass .05 mfd.
- C15—2nd Det. Cathode By-pass 1. mfd.
- C16—2nd Det. Screen By-pass .25 mfd.
- C17—2nd Det. Plate By-pass .0001 mfd.
- C18—Audio De-coupling Condenser .02 mfd.
- C19—Audio Coupling Condenser .006 mfd.
- C20—Audio Plate Condenser .05 mfd.
- C21—Tone Selector Condenser .05 mfd.
- C22—Cathode By-pass Condenser .05 mfd.
- C23—Oscillator Grid Condenser .0001 mfd.
- C24—Oscillator Tuning Condenser .0011 mfd.
- C25—Screen By-pass Condenser 8. mfd.
- C26—Buffer Condenser .08 mfd.
- C27—Filter Condenser 3.5 mfd.
- C28—Field Coil Tuning Condenser .08 mfd.
- C29—Filter Condenser 3.5 mfd.
- S1—Tone Selector Switch
- S2—Main Switch

Main Power Transformer

The various transformer windings may be identified for testing purposes as follows: Four leads are brought out on the terminal strip side and five on the opposite side.

Primary Winding—two terminal strip terminals nearest rear of set.

551, 224, 227 Filaments—heavy wires, terminal strip side.

Plate Center Tap—terminal nearest front of set.

280 Plates—stranded wires, opposite side.

280 Filaments—solid wires, opposite side.

Resistors

The resistors used in the models 31 and 32 receivers conform to the RMA standard of marking and may be identified by the following table of value and colors

Value	Body Color	Tip Color	Dot Color
300 ohms	Orange	Black	Brown
350 "	Orange	Green	Brown
1000 "	Brown	Black	Red
5000 "	Green	Black	Red
10000 "	Brown	Black	Orange
20000 "	Red	Black	Orange
30000 "	Orange	Black	Orange
50000 "	Green	Black	Orange
100000 "	Brown	Black	Yellow
1/2 megohm	Green	Black	Yellow
1 megohm	Brown	Black	Green
2 megohm	Red	Black	Green

ALIGNMENT

The following instructions for the alignment of the condensers in the models 31 and 32 describe the operation as done with any type of special oscillator designed for the adjustment of superheterodyne receivers. Such an oscillator is essential for anyone who handles more than a small amount of service work. Such oscillators are designed to provide ordinary broadcast frequencies, and in addition, a 175 kilocycle for the alignment of the intermediate frequency (I. F.) stages.

Alignment Instructions:

- 1—With 175 KC on the grid of the 551 IF tube Align C9
- 2—With 175 KC on the grid of the 551 1st detector Align C7, C8 and re-check C9
Set the condenser gang at the maximum position and move the dial until the line of light indicator is 1/4" to the right of the 55 division.
- 3—With 1400 KC on the grid of the 551 1st detector Align C6
- 4—Set gang at 600 KC and with 600 KC input on grid of 1st detector Align C10
Re-check as in 3 above.
- 5—Set gang at 1400 KC with input on antenna connection Align C1 and C5

Main Filter Condenser

The main filter condenser unit contains buffer condenser C26, by-pass condensers C27 and C29, and condenser C28 which "tunes" the speaker field coil. The unit is connected as follows:

- Red lead —Speaker plug socket (see wiring diagram)
- Green lead—"F" terminal of 280 socket
- Blue lead—110 volt terminal at main transformer
- Black lead—to R15 (350 ohms) on resistor strip

- Test C27 from Black to Green
- Test C28 from Green to Red
- Test C29 from Red to Ground
- Test C26 from Blue to Ground

MODELS 31-32 Superheterodyne

**MODEL 80
Installation
Notes**

UNITED AMERICAN BOSCH CORP.

Capacitor Plate:

In Figure 5 is shown the means by which this plate is supported underneath the chassis of the automobile. The insulation has been very carefully considered and is so designed that it is unaffected by mud, water, or dust. A location on either side of the car frame or one across the rear, parallel to the axle, will be satisfactory. The plate is adjustable and it is desirable that it be lengthened as much as is possible without interfering with the mechanism of the car. Do not, however, bring the plate too near the motor compartment. Make sure that the clamping nut of the capacitor plate supporting bolt is tightened before fastening the clamp in place on the car frame with the pointed screw. The clamping nut, besides locking the supporting bolt, also serves to reinforce the "C" clamp against any tendency to open. Complete the installation by tightening the set screw and lock nut. The capacitor plate must be mounted as low as possible without interfering with the road clearance, and not too closely to large metal objects, such as "B" battery box, muffler, or car frame.

Chassis:

The chassis mounting is a rigid frame "D" having two adjustable brackets, "C" to support it against the dash board. Refer to Figure 2. In the installation of the set these brackets are assembled and the frame work used as a template to locate the holes in the dash board for the holding bolts. The bracket must be so located that clearance will be obtained for all obstructions. On the engine side, care should be taken to avoid interference with the vacuum tank or other devices mounted there. In using this bracket as a template, do not fail to use the radio set as a guide to obtain clearance for the projection of the set and for the control shaft and the battery cable. Drill the holes as located, using a 5/16" diameter drill in order that unavoidable irregularities in the location of the holes may be taken care of when the set is screwed in place. Next, mount the chassis on its rubber cushions and secure the entire assembly in position. Drive the holding bolts from the front and pull the set securely in place. In some cases, where the dash-board is free of all obstructions, it is possible to dispense with the brackets "C" and bolt the mounting frame directly against the engine bulkhead. This type of installation provides slightly more leg room. The frame is used as a template for laying out the mounting holes as before.

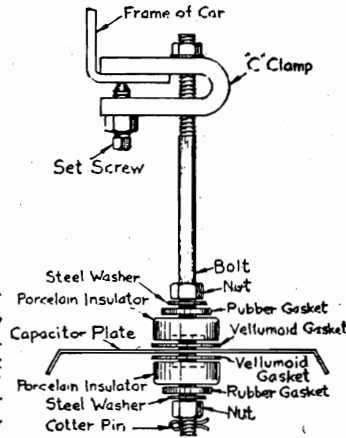

Fig. 5—Capacitor Plate.

Capacitor Coupler:

This unit must be mounted at the nearest convenient point to the capacitor plate. The mounting bracket is permanently fastened to the coupler and it is only necessary to bolt the bracket to the car frame. See Figure 6.

The coupler is provided with two connecting leads. The red lead should be cut to a length just sufficient to reach the capacitor plate and the spade terminal (which is shipped loosely clipped to the wire) soldered to the

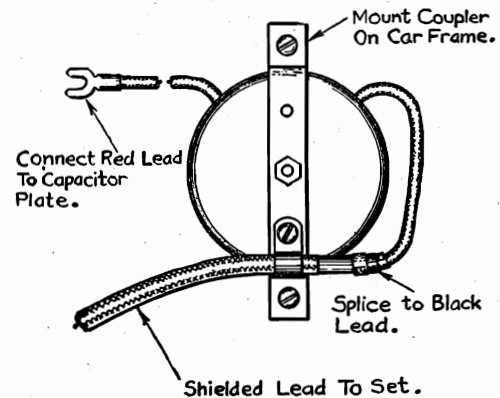

Fig. 6—Coupler.

end. Connection is made at the capacitor plate by means of a terminal screw and clip.

The shielded lead from the receiver must be tightly clamped in the cable clamp provided on the coupler unit. Connect the wire in the shielded lead to the black wire from the coupler and carefully solder and tape the joint. Be careful that the woven shielding is effectively grounded through the clamp provided on the coupler, and is kept back from the joint in order to prevent a short circuit.

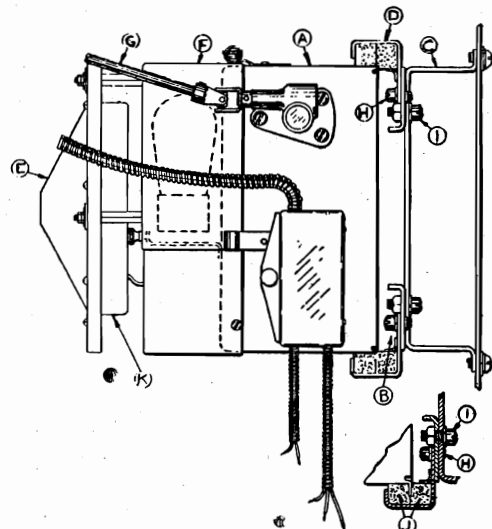

Fig. 2—Radio Chassis.

MODEL 91,92
Voltage
Values

UNITED AMERICAN BOSCH CORP.

NOMENCLATURE — MODEL 91

- R 1—500,000 ohms—Grid Resistor
- R 2—10,000 ohms—Grid Resistor
- R 3—1,000 ohms—Plate Resistor
- R 4—300 ohms—Cathode Divider Resistor
- R 5—20,000 ohms—Cathode Divider Resistor
- R 6—15,000 ohms—Screen Supply Resistor
- R 7—20,000 ohms—Screen Resistor
- R 8—25,000 ohms—Cathode Resistor
- R 9—50,000 ohms—Screen Resistor
- R 10—500,000 ohms—Plate Resistor
- R 11—500,000 ohms—Volume Control
- R 12—100,000 ohms—Grid Resistor
- R 13—500,000 ohms—Tone Control
- R 14—2 megohms—AVC Resistor
- R 15—5,000 ohms—Cathode Resistor
- R 16—100,000 ohms—Grid Resistor
- R 17—Mid Tap Resistor
- R 18—750 ohms—25 cycle only
- R 19—200 ohms—Bias Resistor
- R 20—750 ohms—Bias Resistor
- R 21—350 ohms—Bias Resistor
- R 22—2 megohms—Bias Resistor

- L 1—Antenna Coil
- L 2—1st R.F. Coil
- L 3—Primary } 1st IF Coil
- L 4—Secondary }
- L 5—Primary } 2nd IF Coil
- L 6—Secondary }
- L 7—Cathode Winding } Oscillator Coil
- L 8—Plate Winding }
- L 9—Grid Winding }
- L 10—Primary } Output Transformer T 2
- L 11—Secondary }
- L 12—Field Coil } Loud Speaker
- L 13—Voice Coil }

- C 1—Variable—Antenna Trimmer
- C 2—Variable } Condenser Gang
- C 3—Variable }
- C 4—Variable }
- C 5—Alignment }
- C 6—Alignment }
- C 7—Variable } 1st IF alignment condenser
- C 8—Variable }
- C 9—Variable—2nd IF alignment condenser
- C 10—Variable—Oscillator Series Condenser
- C 11—.05 mfd.—RF coupling condenser
- C 12—.05 mfd.—Plate by-pass condenser
- C 13—.05 mfd.—Grid Condenser
- C 14—.05 mfd.—Cathode by-pass condenser
- C 15—.05 mfd.—Plate by pass condenser
- C 16—.0001 mfd.—AVC condenser
- C 17—.5 mfd.—Cathode by-pass
- C 18—.25 mfd.—Screen by-pass
- C 19—.00025 mfd.—Plate by-pass
- C 20—.006 mfd.—Audio coupling condenser
- C 21—.25 mfd.—Grid by-pass
- C 22—.01 mfd.—Plate by-pass
- C 23—.05 mfd.—Tone Control Condenser
- C 24—.05 mfd.—Grid condenser
- C 25—.05 mfd.—Cathode by-pass
- C 26—.0011 mfd.—Oscillator series condenser
- C 27—.0001 mfd.—Oscillator grid condenser
- C 28—8 mfd.—Screen by-pass
- C 29—.01 mfd.—Buffer condenser
- C 30—16 mfd.—Filter condenser
- C 31—4 mfd.—Filter condenser
- C 32—.01 mfd.—Field shunt condenser

SOCKET VOLTAGES

Stage	Tube	Plate	Screen	Cathode	Grid	Fil.	Plate MA
Osc.	227	100	0	5	2.2	4
1st Det.	551	240	85	0	3.5	2.2	.1
IF	551	240	90	3	.5	2.2	2
2nd Det.	224	90	45	5	4	2.2	.1
AVC	224	10	50	60	.5	2.2	.1
Audio	247	240	240	16	2.2	30
Rect.	280	4.8	25

NOTE: These are average readings obtained with an ordinary set analyzer.

UNITED AMERICAN BOSCH CORP.

MODEL 91, 92
Schematic

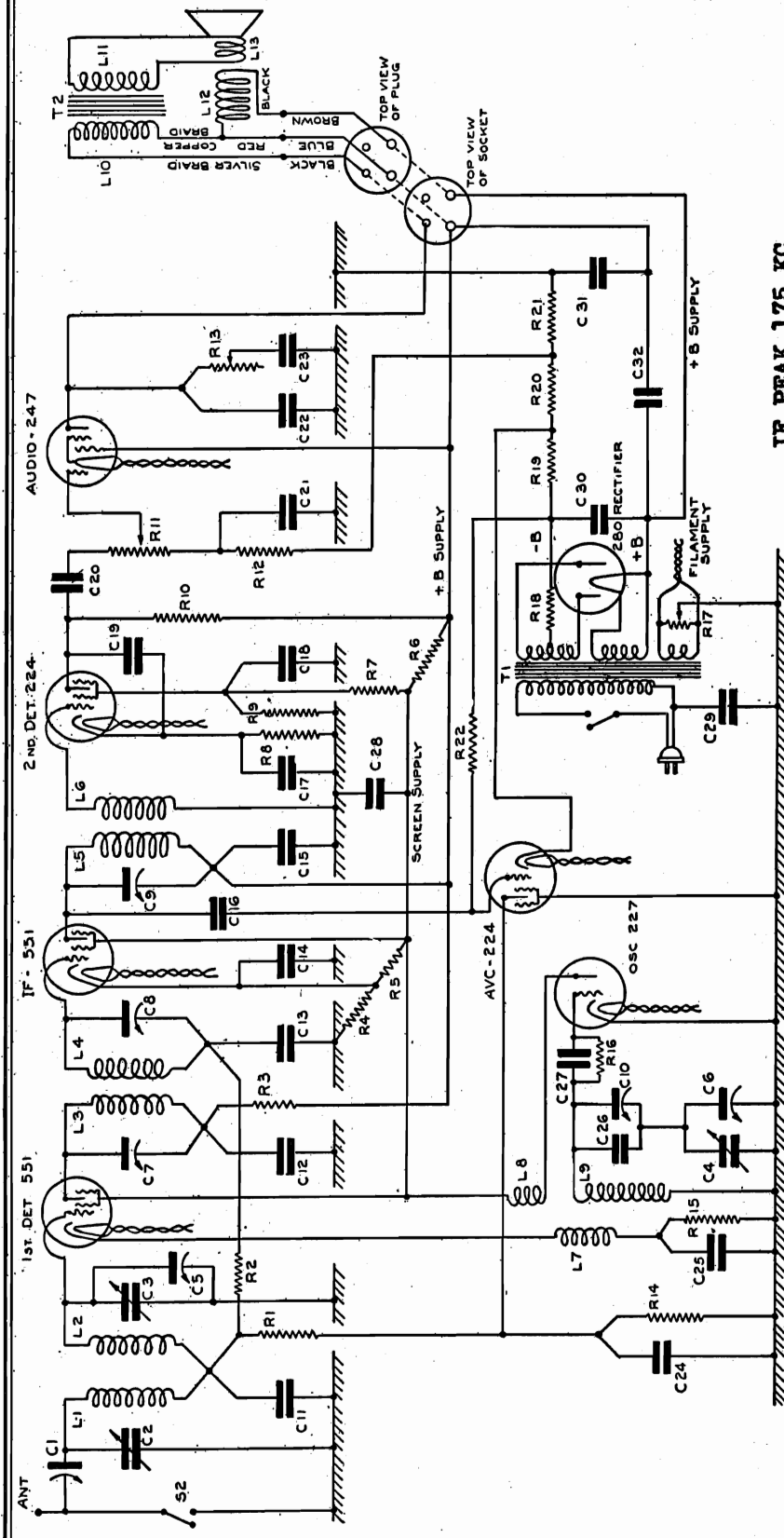

IF PEAK 175 KC

Fig. 2—Schematic Diagram — Model 91

LOCATION OF PARTS

- R 9, R 11, R 13, R 17, C 11, C 19, C 22, C 23, C 28, C 32 on Chassis Base.
- R 3, R 4, R 5, R 6, R 15, R 16, C 14, C 25, C 27 on Resistor Strip.
- R 7, R 8, R 10, R 12, C 17, C 18, C 20, C 21 on Resistor Strip.
- R 1, R 14, R 19, R 20, R 21, C 24, C 29 on Resistor Strip.
- C 10, C 26, L 7, L 8, L 9 on Oscillator Coil Assembly.
- R 2, C 7, C 8, C 12, C 13, L 3, L 4 on 1st IF Coil Assembly.
- R 22, C 9, C 15, C 16, L 5, L 6 on 2nd IF Coil Assembly.
- C 30, C 31 in Housed Filter Assembly.
- C 1, C 2, C 3, C 4, C 5, C 6 on Main Tuning Condenser Gang.

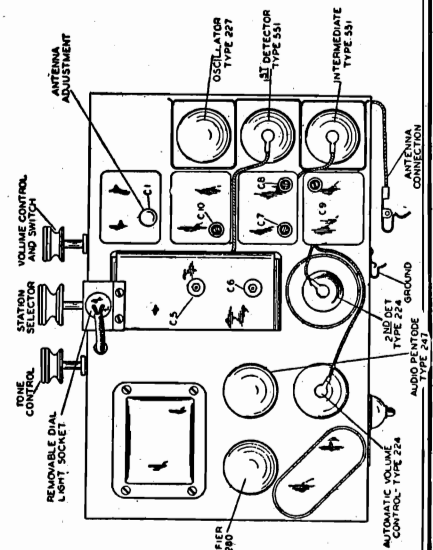
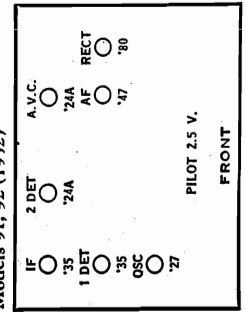

MODEL 100 Auto
Advertised 9-20
Data

UNITED AMERICAN BOSCH CORP.

MODEL 100 SUPERHETERODYNE
MOTOR CAR RADIO

This is a seven tube, superneterodyne receiver with full automatic volume control, push-pull pentode output and electro dynamic speaker. The Magmotor, a source of "B" current, is supplied as an accessory.

TUBES are furnished with receiver as follows:

- | | |
|---|---|
| 1 type 236, radio frequency amplifier. | 1 type 238, diode triode which functions as a second detector, and audio-amplifier, and with its related circuit, furnishes voltage for automatic volume control. |
| 1 type 237, oscillator. | |
| 1 type 236, first detector. | |
| 1 type 236, intermediate frequency amplifier. | |
| 2 type 238, as push-pull audio amplifiers. | |

The type 238 tubes used in the last three positions named above, are pentode power output tubes. All of the tubes used in this receiver are designed especially for automobile use to withstand the vibration and heater voltage fluctuation to which they are subjected.

CHASSIS contains the tubes, tuning condensers and elements of the electrical circuit. (See circuit diagram). It is enclosed in a metal box provided with mounting hooks for easy attachment to a MOUNTING PLATE designed to be mounted either side of the bulkhead. Shielding is complete and internal filtering is so arranged that a minimum of engine interference obtains. Speaker, battery box, control head and plate antenna, find easy attachment to the chassis through cable plug connections inserted on the under side of chassis.

CONTROL UNIT fastens to the steering column and regulates the station selection and volume level. Cable is connected internally with plug for chassis connection.

FLEXIBLE SHAFT connects control unit and chassis drive. It consists of three layers of five strands of wire wound in alternate directions, enclosed in flexible tube: provides accurate tuning unaffected by excessive vibration.

LOUD SPEAKER of electro dynamic type consumes $1\frac{1}{2}$ amperes from storage battery. Cable is connected internally with plug for chassis connection.

MAGMOTOR using permanent magnet field delivers 40 M. A. of plate current at 160 volts (at the tubes) with an "A" battery drain of 2 amperes. Self-enclosed with filtering to eliminate brush interference. Cable connected internally with plug for chassis connection.

IGNITION SUPPRESSION is accomplished through use of 9 resistors in ignition circuits and grounding of cable shields.

BATTERY BOX of heavy weather proof steel, for optional use to contain 3 special Heavy Duty automobile type "B" batteries. Battery box hangs from floor boards of car, access from the top. Cable furnished with plug for chassis connection.

PLATE ANTENNA for optional use when there is no roof antenna in car: clamps to frame of car with hardened set screws. Step down transformer fastened to bracket; cable attached to plate with plug for chassis connection.

"B" Battery Cable

- B-	Black
+67 $\frac{1}{2}$ B	White
+135 B	Red

UNITED AMERICAN BOSCH CORP

MODEL 100 Auto
Advertised 9-20
Schematic
Values

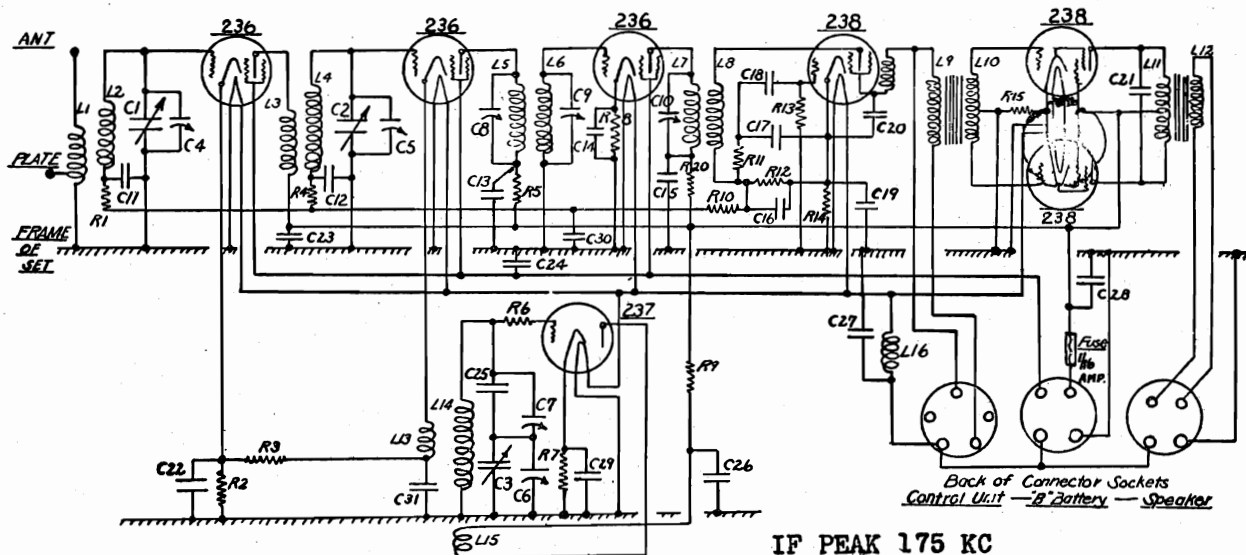

Model 100 (Motor Car) (1932)

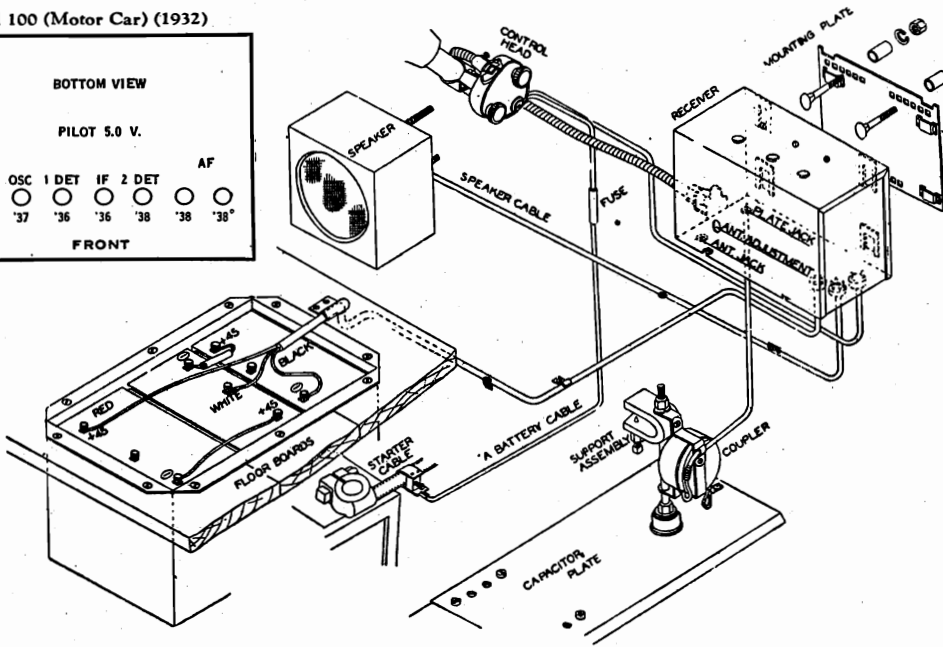
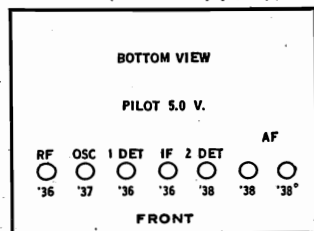

Stage	Tube	Fil.	Carbode	Grid	Screen	Plate	A/A
RF	236	5.8	5	1.0	60	130	1
Osc	237	5.8	3.0	8.0	55	130	3
1st Det	236	5.8	9.0	5	60	120	1.5
IF	238	5.8	2.0	2.5	120	*1	*6
2nd Det	238	5.8	5.0	1	135	130	10
Audio	238	5.8	12	12	135	130	10
Audio	238	5.8	12	12	135	130	10

Note: The values in the table are only approximate, due to unavoidable differences in tube

Symbols and Electrical Values

- R1 — 10,000 ohms
- R2 — 3,000 ohms
- R3 — 5,000 ohms
- R4 — 10,000 ohms
- R5 — 1,000 ohms
- R6 — 1,000 ohms
- R7 — 3,000 ohms
- R8 — 1,500 ohms
- R9 — 5,000 ohms
- R10 — .5 megohm
- R11 — 100,000 ohms
- R12 — .5 megohm
- R13 — .1 megohm
- R14 — 2,000 ohms
- R15 — 1,500 ohms
- R16 — 1,000 ohms
- C1 — Condenser
- C2 — Gang with Alignment
- C3 — Condensers
- C4 — Condensers
- C5 — Condensers
- C6 —
- C7 — 100 to 200 mmf.
- C8 — 75 to 140 mmf.
- C9 — 75 to 140 mmf.
- C10 — 75 to 140 mmf.
- C11 — .05 mfd.
- C12 — .05 mfd.
- C13 — .05 mfd.
- C14 — .05 mfd.
- C15 — .05 mfd.
- C16 — .00025 mfd.
- C17 — .0001 mfd.
- C18 — .01 mfd.
- C19 — .5 mfd.
- C20 — .0011 mfd.
- C21 — .004 mfd.
- C22 — .05 mfd.
- C23 — .05 mfd.
- C24 — .25 mfd.
- C25 — 1100 mmf.
- C26 — .05 mfd.
- C27 — .25 mfd.
- C28 — .25 mfd.
- C29 — .05 mfd.
- C30 — .25 mfd.
- C31 — .05 mfd.
- L1 — Antenna Coil
- L2 — Radio Frequency Coil
- L3 — Radio Frequency Coil
- L4 —
- L5 — Intermediate Coil
- L6 — Intermediate Coil
- L7 — Intermediate Coil
- L8 — Intermediate Coil
- L9 — Audio Input Transformer
- L10 — Audio Output Transformer
- L11 — Audio Output Transformer
- L12 — Audio Output Transformer
- L13 — Oscillator Coil
- L14 — Oscillator Coil
- L15 — Oscillator Coil
- L16 — Filter

**MODEL 108
Police Auto
Data**

UNITED AMERICAN BOSCH CORP.

ADJUSTMENT OF THE RECEIVER.

After the receiver has been installed it is necessary to adjust it to the frequency of the transmitting station. Even if the set has been shipped with the proper setting, a slight readjustment will be necessary. The procedure is the same in both cases.

The positions of the four alignment condensers which take care of the adjustment are shown on the installation drawing. The car should be in the vicinity of the transmitting station when the alignment is made, in order to assure adequate signal strength. Proceed as follows:

1. Switch the receiver "on" and turn the volume and sensitivity control to maximum position.
2. Adjust OSCILLATOR condenser until the signal is picked up, using a special screw driver with an insulated tip. (Such an American Bosch Service Tool #432).
3. Reduce the sensitivity control until the station can just be heard, and re-adjust the OSCILLATOR until the signal is loudest.
4. Reduce the sensitivity control until the station can just be heard and adjust the RF alignment for maximum volume. As the volume increases, reduce the sensitivity as far as possible. This permits a sharper adjustment to be made, as the ear is more sensitive to changes in volume when the signal is faint.
5. Screw the SERIES antenna condenser in as far as possible. Pay no attention to the signal while doing this.

6. Attempt to find a position of the SHUNT condenser which will give maximum volume. Always reduce the sensitivity control when increased response of the set results from the various adjustments which you are making.

7. If no position of the SHUNT condenser will give a point of maximum volume or "peak", unscrew it as far as possible and slowly unscrew the SERIES condenser until the adjustment is obtained. Endeavor to obtain this adjustment with the SERIES condenser screwed in as far as possible.

The relative position of the shunt condenser is unimportant.

FUSES

A 1/16 ampere fuse is located in the B Battery jumper wire, as described under "B" Battery Cable". The "A" fuse is located in the control box and may be reached for replacement by simply removing the cover.

C1	75 to 140 mmf	Antenna Series Condenser
C2	7 to 70 mmf	Antenna Shunt Condenser
C3	75 to 140 mmf	Tuning Condenser (1st. Det.)
C4	75 to 140 mmf	Tuning Condenser (I.F.)
C5	75 to 140 mmf	Tuning Condenser (I.F.)
C6	75 to 140 mmf	Tuning Condenser (2nd Det.)
C7	100 to 280 mmf	Oscillator Tuning Condenser
C8	.05 mfd	By-pass Condenser (RF)
C9	.05 mfd	By-pass Condenser (RF)
C10	.05 mfd	By-pass Condenser (RF)
C11	.05 mfd	By-pass Condenser (1st. Det.)
C12	.05 mfd	By-pass Condenser (1st. Det.)
C13	.05 mfd	By-pass Condenser (IF)
C14	.05 mfd	By-pass Condenser (IF)
C15	.25 mfd	By-pass Condenser (2nd. Det.)
C16	.25 mfd	By-pass Condenser (2nd Det.)
C17	.00025 mfd	By-pass Condenser (2nd Det.)
C18	.00025 mfd	By-pass Condenser (2nd Det.)
C19	.006 mfd	Audio Condenser
C20	.05 mfd	Audio Condenser
C21	.5 mfd	Audio Blocking Condenser
C22	.25 mfd	Heater By-pass Condenser
C23	.25 mfd	Screen By-pass condenser
C24	.0001 mfd	AVC Condenser
C25	.05 mfd	By-pass Condenser (1st. Det.)
C26	.05 mfd	By-pass Condenser (Osc.)
C27	.05 mfd	By-pass Condenser (Osc.)
C28	.25 mfd	By-pass Condenser (AVC)
C29	.25 mfd	By-pass Condenser (AVC)

R1	10,000 ohms	Grid Resistor (RF)
R2	10,000 ohms	Grid Resistor (1st. Det.)
R3	1,000 ohms	Plate Resistor (1st. Det.)
R4	1,000 ohms	Cathode Resistor (IF)
R5	1 megohm	Cathode Resistor (2nd. Det.)
R6	500,000 ohms	Screen Resistor (2nd. Det.)
R7	500,000 ohms	Plate Resistor (2nd. Det.)
R8	1 megohm	Audio Grid Resistor
R9	100,000 ohms	Plate Resistor (2nd Det.)
R10	1,000 ohms	Cathode Resistor (RF)
R11	2 megohm	AVC Grid Resistor
R12	100,000 ohms	AVC Resistor
R13	500,000 ohms	AVC Plate Resistor
R14	1,000 ohms	Oscillator Plate Resistor
R15	2,000 ohms	Oscillator Cathode Resistor
R16	20,000 ohms	1st. Det. Cathode Resistor
R17	10,000 ohms	2nd. Det. Plate Resistor

UNITED AMERICAN BOSCH CORP.

MODEL 108
Police Auto
Schematic

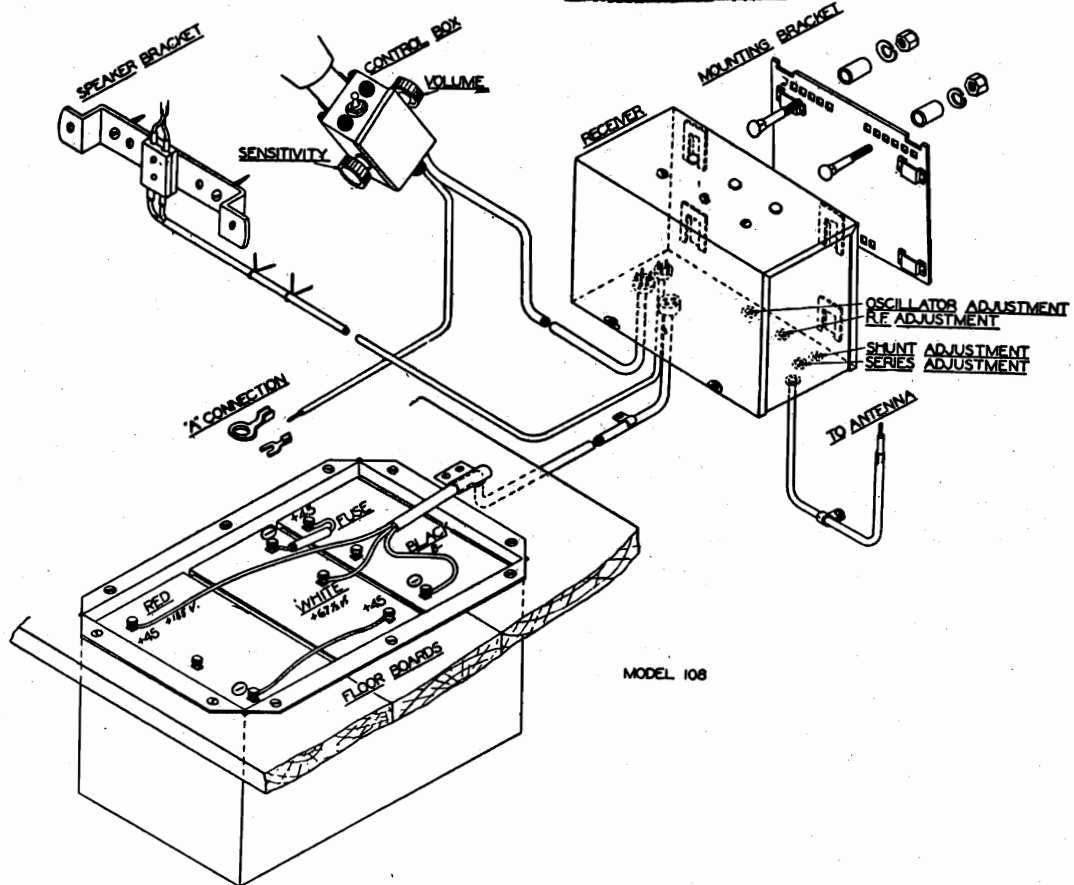
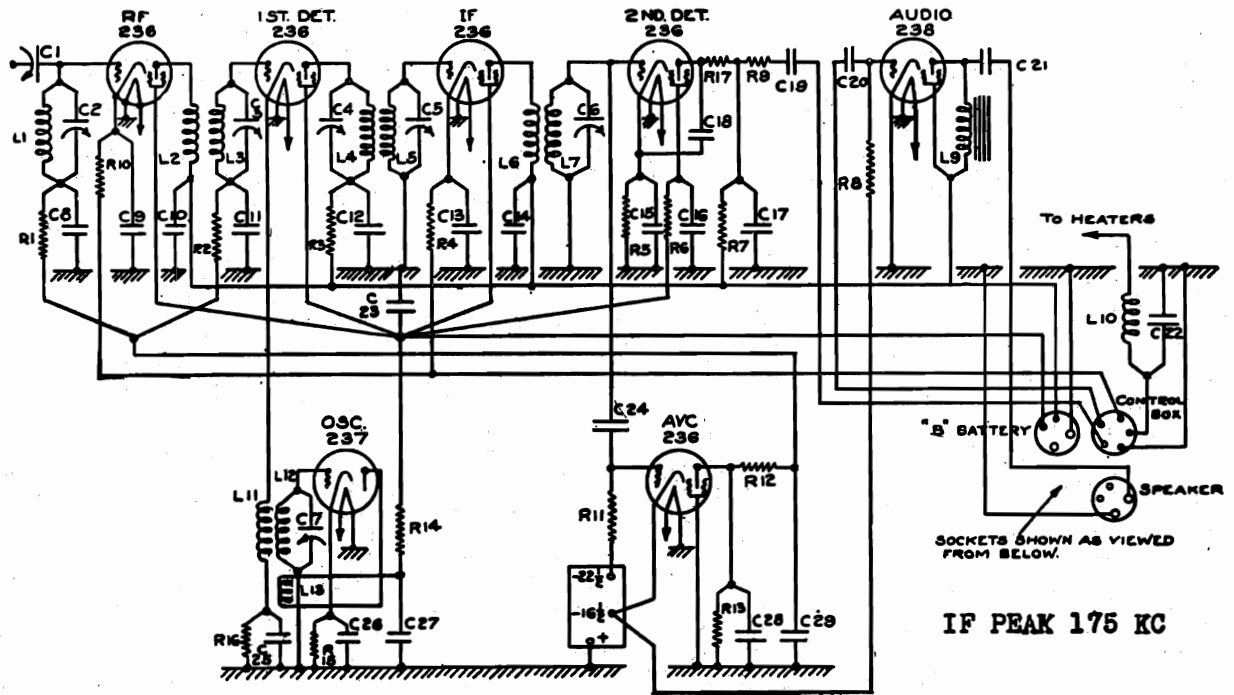

MODEL 205, 206, 5-A
205-A

UNITED AMERICAN BOSCH CORP.

Voltage - Data

STAGE	TUBE	FIL.	PLATE	SCREEN	CATHODE	GRID	PLATE MA.
1st RF	551	2.3	250	90	2.5	3.0	4.5
2nd RF	551	2.3	250	90	2.5	3.0	4.5
Det.	224	2.3	*150	*20	3.0	1.5	.5
Audio	247	2.3	250	250	--	*16	*32
Rect.	280	4.8					
Plate current of each plate · 20							

The readings were made with the volume control in the full "on" position.
*These voltages are the correct values. The average test kit will give much lower readings, (as low as 1/10 of these values) due to the low resistance of the meters compared to the high resistance included in the detector plate and screen circuits and the audio grid circuit.

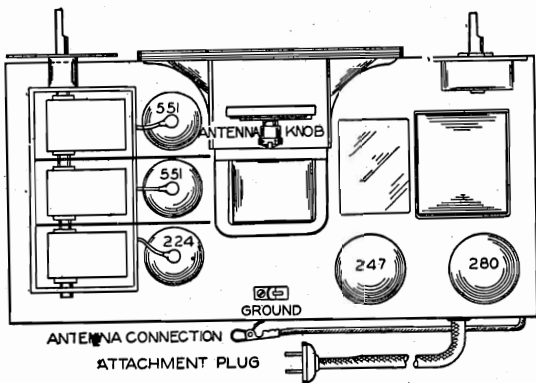

IMPORTANT

Antenna Adjustment: The small knob located on the loud speaker must be adjusted at the time of installation to obtain the best reception. Make this adjustment on a weak station which is received at some point near 30 on the dial and then re-check the adjustment at several other points to make sure that it has been accurately done.

Chassis: The chassis may be removed by pulling off the knobs and unscrewing the felt feet.

Model 5A, Edition 2 (1931)

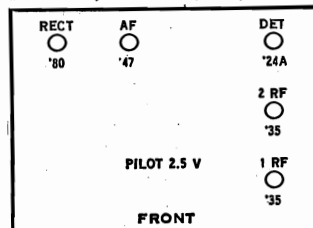

RESISTOR COLOR CODE

200 ohms ----- Red ---- Black -- Brown	50,000 ohms ---- Green -- Black -- Orange
400 ohms ----- Yellow - Black -- Brown	100,000 ohms ---- Brown -- Black -- Yellow
10,000 ohms ---- Brown -- Black -- Orange	500,000 ohms ---- Green -- Black -- Yellow
15,000 ohms ---- Brown -- Green -- Orange	1 megohm ----- Brown -- Black -- Green
20,000 ohms ---- Red ---- Black -- Orange	2 megohms ----- Red ---- Black -- Green

TEMPORARY CONDENSED SERVICE PARTS LIST FOR TYPE R.S. 205 RADIO RECEIVER

MAIN ASSEMBLIES	KNOBS	100727 Resistor (100,000 ohms)
103655 Chassis (with tubes)	102445 Volume and tuning knobs	100194 Resistor (1/2 megohm)
102280 Speaker	100929 Trimmer cond. knob	100815 Resistor (1 megohm)
103878 Cabinet with plates	MISCELLANEOUS PARTS	100196 Resistor (2 megohms)
COILS	101895 Dial with scale	99412 Mid tap resistance
101858 Field coil (speaker)	102282 Diaphragm for speaker	SOCKETS
102438 R. F. coil complete	98713 Lamp for dial	101890 Dial light socket
102243 R. F. primary coil	RESISTORS	102447 Tube socket for '24 tube
102439 Antenna coil	102342 Volume control & switch	102449 Tube socket for '80 tube
CONDENSERS	102437 Volume control only	102446 Tube socket for '47 tube
102178 By-pass assembly	102314 Resistor (200 ohms)	102448 Tube socket for '51 tube
102022 Antenna trimmer	102177 Resistor (400 ohms)	SWITCH
101143 Fixed (.0001 mfd.)	100825 Resistor (10,000 ohms)	101930 Switch with (2) nuts
101881 Large filter cond.	101404 Resistor (15,000 ohms)	TRANSFORMER
103695 Cond. (.01 mfd-4ply)	100813 Resistor (20,000 ohms)	102551 Output transformer
100705 Cond. (.006 mfd.)	100512 Resistor (50,000 ohms)	101939 Power transformer

UNITED AMERICAN BOSCH CORP.

MODEL 205,206,5-A

205-A

Schematic - Data

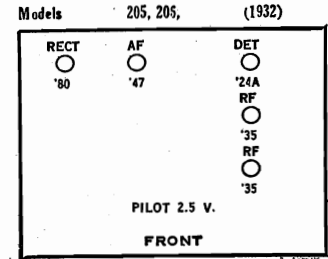
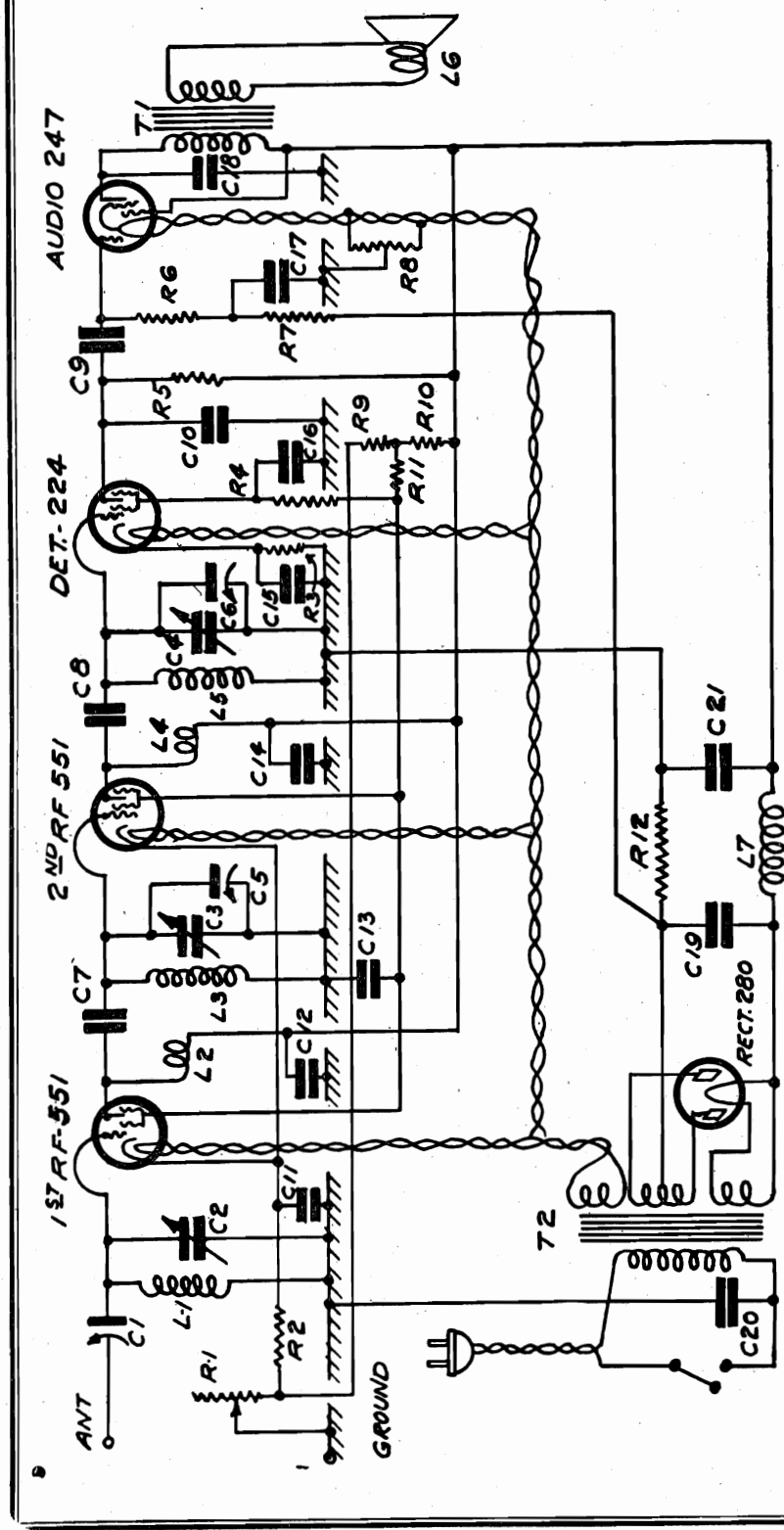

ELECTRICAL VALUES

- R1 - 10,000 ohms
- R2 - 200 ohms
- R3 - 50,000 ohms
- R4 - 2 megohms
- R5 - 1 megohm
- R6 - 500,000 ohms
- R7 - 100,000 ohms
- R8 - Center Tap
- R9 - 20,000 ohms
- R10 - 15,000 ohms
- R11 - 10,000 ohms
- R12 - 400 ohms
- C1 - Trimmer
- C2 - Tuning
- C3 - Tuning
- C4 - Tuning
- C5 - Alignment
- C6 - Alignment
- C7 - Coupling
- C8 - Coupling
- C9 - .006 mfd.
- C10 - .0001 mfd.
- C11 - .05 mfd.
- C12 - .05 mfd.
- C13 - .25 mfd.
- C14 - .01 mfd.
- C15 - 1. mfd.
- C16 - .25 mfd.
- C17 - .05 mfd.
- C18 - .01 mfd.
- C19 - 8. mfd.
- C20 - .01 mfd.
- C21 - 4 mfd.
- L1 - Ant. Coil
- L2 - Primary
- L3 - Secondary
- L4 - Primary
- L5 - Secondary
- L6 - Voice Coil
- L7 - Field Coil

Note: Electrolytic filter condensers C19 and C21 are a single assembly. Condensers C11 to C18 inclusive are also a single assembly contained in the square can underneath the base plate.

UNITED AMERICAN BOSCH

MODEL 224

IMPORTANT! UNLESS OTHERWISE SPECIFIED DIMENSIONS ARE IN MILLIMETERS - INCHES - MUST BE ACCURATE WITHIN ± 0.03 mm - ± 0.00125 IN. - WORK TO DIMENSIONS - DO NOT SCALE DRAWING. THREADS TO BE FINISH FIT TO THREAD GAUGE - FINISH WHERE INDICATED - NO BURRS.

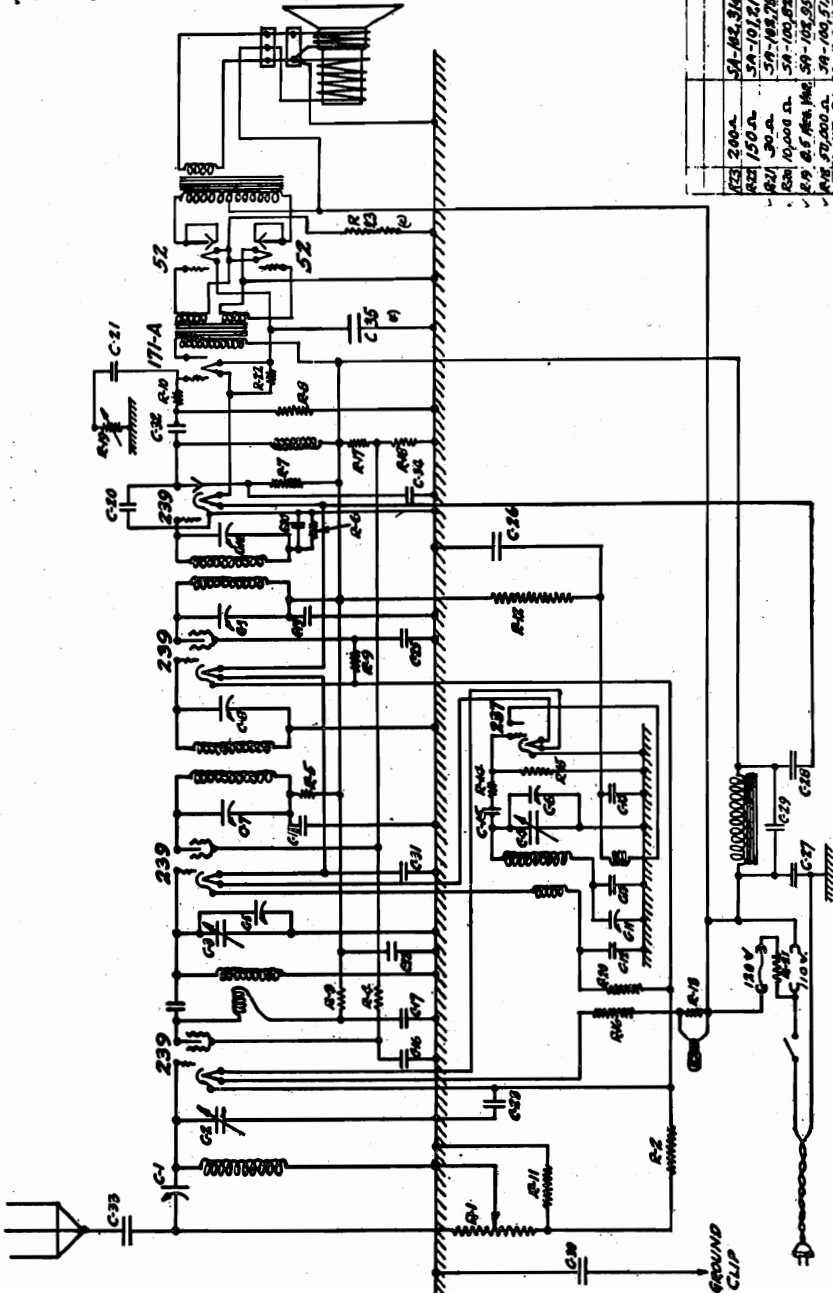

1A	100,000.0	5A-103,717
1B	15,000.0	5A-101,402
1C	10,000.0	5A-100,727
1D	5,000.0	5A-100,516
1E	2,000.0	5A-101,404
1F	1,000.0	5A-100,728
1G	500.0	5A-100,729
1H	250.0	5A-101,210
1I	100.0	5A-102,532
1J	50.0	5A-102,533
1K	25.0	5A-102,534
1L	12.5	5A-102,535
1M	6.25	5A-102,536
1N	3.125	5A-102,537
1O	1.5625	5A-102,538
1P	0.78125	5A-102,539
1Q	0.390625	5A-102,540
1R	0.1953125	5A-102,541
1S	0.09765625	5A-102,542
1T	0.048828125	5A-102,543
1U	0.0244140625	5A-102,544
1V	0.01220703125	5A-102,545
1W	0.006103515625	5A-102,546
1X	0.0030517578125	5A-102,547
1Y	0.00152587890625	5A-102,548
1Z	0.000762939453125	5A-102,549
2A	200.0	5A-102,314
2B	150.0	5A-101,210
2C	100.0	5A-102,540
2D	75.0	5A-102,541
2E	50.0	5A-102,542
2F	25.0	5A-102,543
2G	12.5	5A-102,544
2H	6.25	5A-102,545
2I	3.125	5A-102,546
2J	1.5625	5A-102,547
2K	0.78125	5A-102,548
2L	0.390625	5A-102,549
2M	0.1953125	5A-102,550
2N	0.09765625	5A-102,551
2O	0.048828125	5A-102,552
2P	0.0244140625	5A-102,553
2Q	0.01220703125	5A-102,554
2R	0.006103515625	5A-102,555
2S	0.0030517578125	5A-102,556
2T	0.00152587890625	5A-102,557
2U	0.000762939453125	5A-102,558
2V	0.0003814697265625	5A-102,559
2W	0.00019073486328125	5A-102,560
2X	0.000095367431640625	5A-102,561
2Y	0.0000476837158203125	5A-102,562
2Z	0.00002384185791015625	5A-102,563

RECORD OF CHANGES
 1/ CHANGED 5A-102,581
 (1000.0) To 5A-102,536
 (2000.0) CR-7000-2
 2/ CHANGED 5A-102,581
 (1000.0) To 5A-102,536
 (2000.0) CR-7000-2
 3/ CHANGED 5A-102,581
 (1000.0) To 5A-102,536
 (2000.0) CR-7000-2
 4/ CHANGED 5A-102,581
 (1000.0) To 5A-102,536
 (2000.0) CR-7000-2
 5/ CHANGED 5A-102,581
 (1000.0) To 5A-102,536
 (2000.0) CR-7000-2
 6/ CHANGED 5A-102,581
 (1000.0) To 5A-102,536
 (2000.0) CR-7000-2
 7/ CHANGED 5A-102,581
 (1000.0) To 5A-102,536
 (2000.0) CR-7000-2
 8/ CHANGED 5A-102,581
 (1000.0) To 5A-102,536
 (2000.0) CR-7000-2
 9/ CHANGED 5A-102,581
 (1000.0) To 5A-102,536
 (2000.0) CR-7000-2
 10/ CHANGED 5A-102,581
 (1000.0) To 5A-102,536
 (2000.0) CR-7000-2

MATERIAL AND SPECIFICATION	LENGTH PER 1000 PCS.	WEIGHT PER 1000 PCS.	FIRST MADE FOR
WIRING DIAGRAM MODEL 224			

UNITED AMERICAN BOSCH CORPORATION
 FACTORY: SPRINGFIELD, MASS.

THE SERVICE STAGE
 FOR THIS PART IS
 SERVICE No.

SCALE

DI-103.939

MODEL 312, 313
Adjustments

UNITED AMERICAN BOSCH CORP.

TEST OF SENSITIVITY ON MODEL #312

NOTE While making adjustments on chassis make sure that the signal does not overload any of the tubes, otherwise incorrect adjustment will result.

I. F. ADJUSTMENT

- a. Set volume control on max. tone control on treble and ground antenna lead.
- b. Connect the 175 Kc. I.F. signal generator to the grid of the 1st. det.
- c. Align secondary of 3rd I.F. transformer for max. output.
- d. With the lossor on the grid of the 2nd I.F. tube, adjust condenser on primary (front one) of 2nd I.F. coil. (e) Holding the lossor on the plate side of 2nd I.F. coil, adjust the condenser on secondary (rear one) of 2nd I.F. coil.
- f. With the lossor on the grid of the 1st I.F. coil, adjust the condenser on secondary (front one) of 1st I.F. coil. (g) Holding the lossor on the plate side of the 1st I.F. coil, adjust the condenser on secondary (rear one) of 1st. I.F. coil.
- h. Check sensitivity of I.F. Sensitivity limits are 200 mv. on 1st. det. grid. 700 - 312 on 1st I.F. grid. 18,000 on 2nd I.F. grid.

OSCILLATOR ADJUSTMENT

- a. Adjust pointer to mark past 550 Kc. (b) Connect ant. lead of the R.F. signal generator to grid of 1st. det. (c) Set the microvolter dial at 1400 Kc.
- d. Adjust oscillator alignment condenser until max. output is obtained.

NOTE When adjusting the oscillator 2 peaks may be obtained. Set the align. condenser down tight; turn to the right, one peak at (1575 Kc.) will be noted about $\frac{1}{2}$ of a turn out. Set on the (1575 Kc.) peak, otherwise the oscillator will not track in the center of the scale. (e) Connect ant. lead to microvolter. DO NOT TOUCH OSCILLATOR CONDENSER.

- f. Adjust antenna, R.F. and detector alignment condensers for max. output.
- g. Set the signal generator dial to 600 Kc. and pointer of the chassis to 600.
- h. Adjust the condenser on the oscillator coil (on side of chassis) until max. output is obtained and note sensitivity.

NOTE Disregard the pointer reading entirely during this adjustment. This is best obtained by adjusting the trimmer, retune & noting the output, then readjust & retuning until maximum output is obtained.

R. F. ADJUSTMENT

- a. Set the dials at 1400 Kc. and readjust all trimmers peaking oscillator condenser first; note sensitivity at 1400, 1000, 700, 550.
limits are 7 3 3 5.
- b. Check switch, volume control action and tone control. (c) Check power output. Should be 5 volts. (d) Check for hum, note any distortion while making tests.
- e. Check A.V.C. action by tuning meter. Should A.V.C. at 40 mv.
- f. Tap the 2nd. det. tube & check noise. (g) Check relay at 954 Kc. with control at maximum. It should release at 300 mv.

AIR TEST

- a. Connect ant. lead to outdoor ant. (b) Check for tone quality and carrier hum
- c. Check for selectivity & stability. (d) Check vol. control action & switch. (e) Check for power output. Should be ___ volts 10 watts. (f) Check for noise with ant. grounded.

U. S. RADIO & TELEVISION CORP.

MODEL 7
Schematic

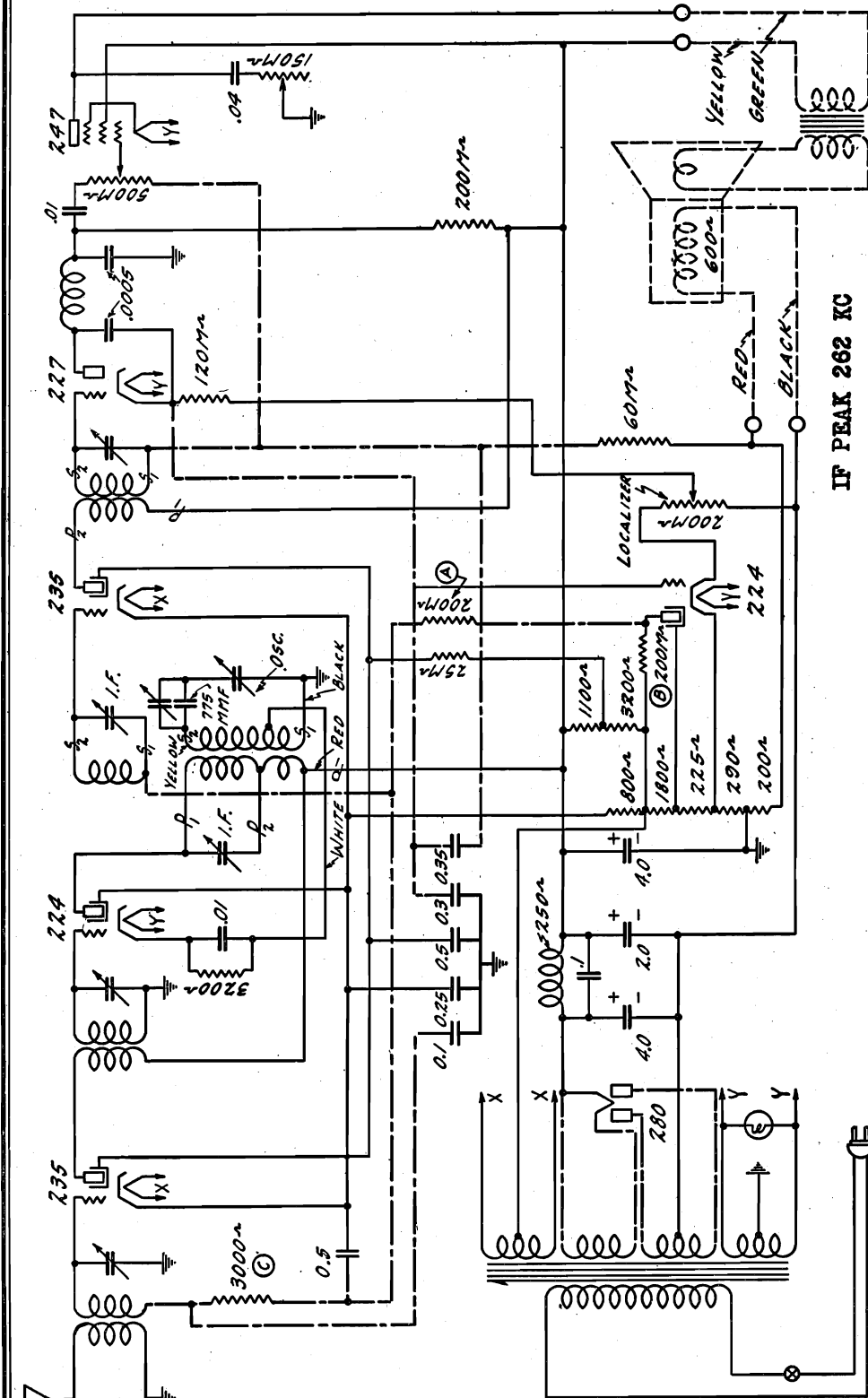

- IF PEAK 262 KC
 --- RUBBER COVERED WIRE
- Ⓐ AFTER SERIAL N^o 1,062,700 RESISTOR WILL BE OMITTED.
 - Ⓑ AFTER SERIAL N^o 1,062,700 RESISTOR WILL BE 900M^Ω.
 - Ⓒ AFTER SERIAL N^o 1,070,000 RESISTOR CHANGED TO 5 μ h. CHOKE.

Note
 There are certain features to be noted in this receiver.
 The mixer tube is of the auto-dyne type, wherein it functions as the mixer (1st detector) and at the same time functions as the oscillator.

Models 7A, 7B (1931)

RECT	○	'80
	○	'47
	○	'24A
	○	'27
	○	'35
	○	'24A
	○	'35

PILOT 2.5 V.
 MODEL 7 CHASSIS
 FRONT

**MODEL 7
Alignment
Voltage
Data**

U. S. RADIO & TELEVISION CORP.

Condenser Alignment

Aligning Intermediate Condensers—First align the intermediate condensers. A non-metallic screw driver is preferable for this. Adjust the signal generator for a signal of 282 K.C. The Localizer knob should be at the normal position as explained in the section on this control or else it may be turned to the extreme counter-clockwise position. One of the best ways of reading the output is by means of a rethier type meter. This meter, if of low range, is connected across the secondary of the output transformer in the speaker. If it is of a high range, it may be connected across the primary of the transformer in series with a large condenser to prevent the flow of D.C. plate current through the meter. In either method of connection, opening the voice coil of the speaker will give a better deflection on the output meter.

Remove the grid cap from the grid connection of the 224 1st detector tube and connect the lead from the signal generator to the grid of the 224 1st detector. The tube shield should be on and the chassis grounded. One way to make this connection is to bring the antenna lead from the signal generator through the place in the shield through which the grid wire passes. A grid capacitor will facilitate making this connection. This lead, of course, should be insulated. Another way of making this connection is to cut a hole of about 1" diameter in a No. 7 chassis tube shield over the 1st detector tube. The signal generator lead can then be passed through this hole to the grid connection of the 224 tube. Connect the ground lead of the signal generator to the ground post of the chassis.

The oscillator coil must be shorted out by grounding the lead from the tap on the secondary. This can be done conveniently by connecting a jumper from ground to the lug on the 3,200 ohm resistor at the end which connects to the oscillator. There exists condenser adjusting screws on the rear of the bottom of the chassis. There are two on the porcelain base of the oscillator and one on the porcelain base of the 2nd I.F. and 1st I.F. transformer assembly. Part No. 3571 and Part No. 3572 are used for the oscillator transformer assembly, Part No. 3644. The volume control should be at maximum setting. Attenuate the signal from the signal generator until the output is 75 volts rms in order to prevent any action of the A.V.C. Then adjust the three intermediate condenser screws until maximum output is obtained on the output meter, keeping the output at 75 volts or less. After all three have been adjusted the first time, go over them again and check the setting for maximum output.

Aligning R.F. and Oscillator Condensers—For adjusting the R.F. and oscillator condensers the signal input from the signal generator should be made to the antenna post. Adjust the signal generator for a signal of exactly 1400 K.C. Then turn the tuning condenser rotor until the pointer is at exactly 1400 on the dial scale. Then adjust the three trimmers on the tuning condenser for maximum output adjusting the oscillator trimmer first (trimmer nearest back of chassis). Turn the screws up or down until greatest deflection on output indicating meter is obtained. Keep the output below 75 volts as explained above.

The next step is to adjust the oscillator 600 K.C. trimmer condenser. The adjusting screw for this condenser is reached from the top of the

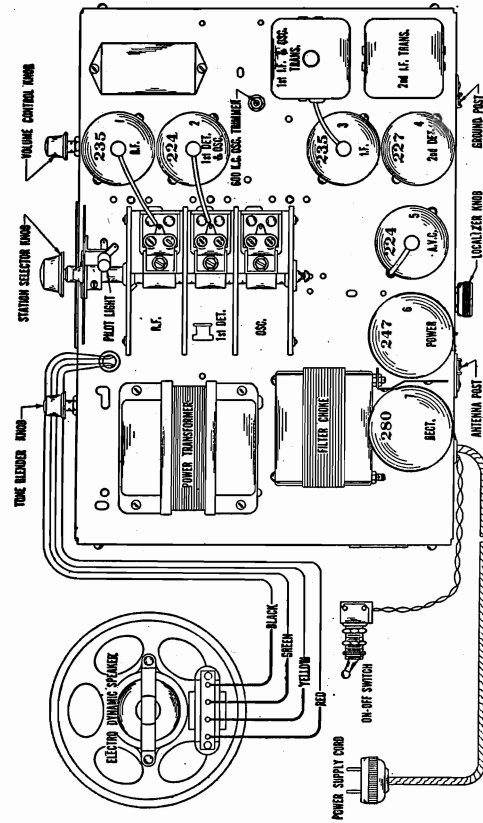

—Top View of No. 7 Chassis showing Tube Sequence and Speaker Connections
No. 7 CHASSIS—VOLTAGES AT SOCKETS—LINE VOLTAGE 115
VOLUME CONTROL AT MAXIMUM—LOCALIZER AT NORMAL SETTING

Type of Tube	Position of Tube	Function	Across Filament or Heater	Plate to Cathode	Screen to Cathode	Screen to MA	Screen to Cathode	Cathode to Heater	Plate to MA	Grid Test MA
235	1	R.F.	2.35	150	70 ⁽²⁾	.9	4.5	4.5	2.7	4.2
224	2	1st Det. & Osc.	2.35	240	93	.3	6.4	6.4	1.8	2.6
235	3	I.F.	2.35	150	70 ⁽²⁾	.9	4.5	4.5	2.7	4.2
227	4	2nd Det.	2.35	150	12-24 ⁽³⁾	0	0-10 ⁽³⁾	0-10 ⁽³⁾	2-5 ⁽³⁾	21-51 ⁽³⁾
224	5	A.V.C.	2.35	60	0-15 ⁽³⁾	9	12	12	0	0
247	6	Power	2.35	220	16 ⁽⁵⁾	240	6.4	34	34	40
280	7	Rect.	4.9					39	39	
										Per Plate

(1) This voltage read across 800 ohm resistor.
 (2) Voltage as read with 600,000 ohm meter.
 (3) Varies with setting of localizer. Voltages read with high resistance meter.
 (4) Current zero with no signal and localizer at normal position.
 (5) The voltage read across 200 ohm section of voltage divider.

SETTING THE LOCALIZER.

Turn the localizer knob counter-clockwise as far as it will go. Then turn the knob one quarter turn clockwise. Next tune in a fairly strong signal and reduce the volume by means of the volume control knob on the front panel. Then turn the localizer knob to the extreme clockwise position. This will cause plate current cutoff in the RF and IF tubes. Then turn the knob slowly in a counter-clockwise direction until the signal is again heard. With a slight additional turn in the same direction the signal builds up sharply to full strength and this is the correct position of the localizer setting. This adjustment should not be changed unless the set is reinstalled or the tubes are changed. Incorrect adjustment of this knob will control the action of the AVC tube in such fashion that the automatic action will commence too soon or too late.

U. S. RADIO & TELEVISION CORP.

MODEL 7
Transformer
Data 25 cycle.

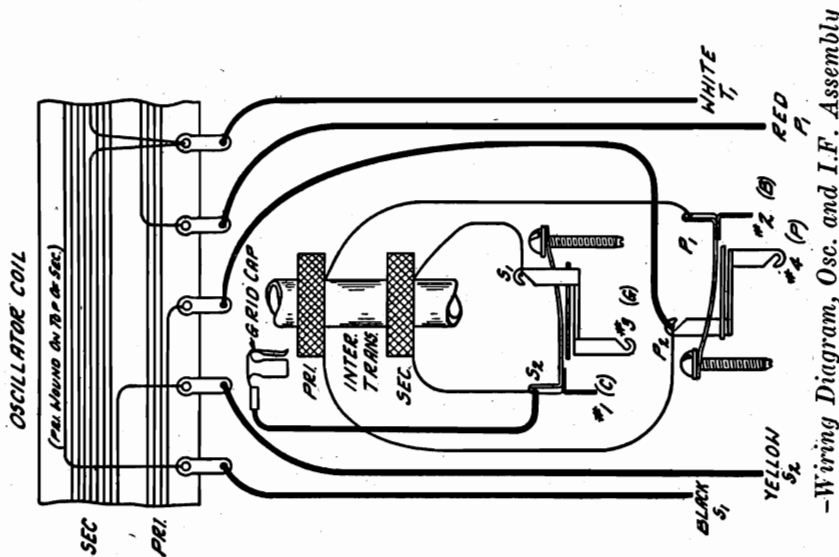

-Wiring Diagram, Osc. and I.F. Assembly

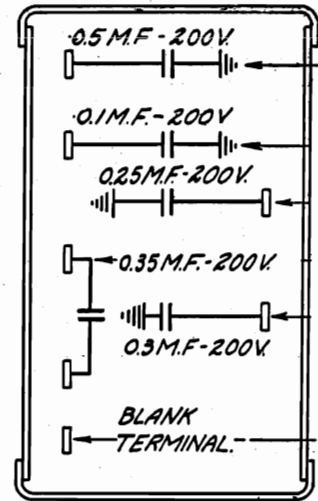

5 Section Condenser Internal Wiring

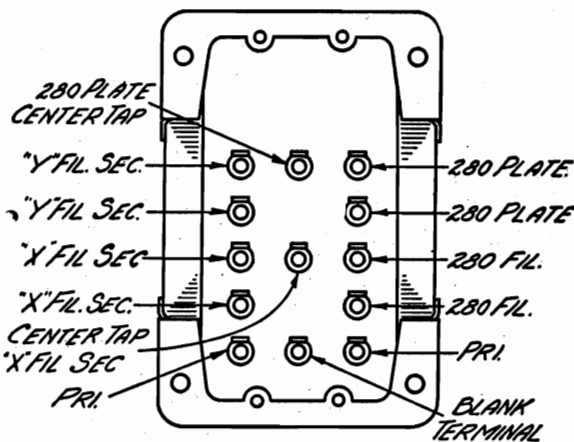

-Power Transformer Terminals

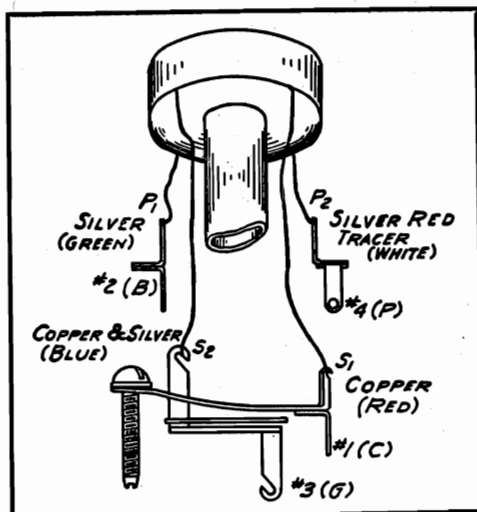

-Wiring Diagram, 2nd I.F. Assembly

No. 7X Chassis—25 Cycle, 115 Volt

Chassis No. 7X is almost identical in construction with chassis No. 7, except that it is designed for 25 cycle, 115 volt operation. All parts as used in the No. 7 chassis are used in the No. 7X chassis with the exception of the power transformer, .1 Mfd. choke tuning condenser and 2 Mfd. electrolytic filter condenser. These items are replaced by a 25 cycle power transformer, .35 Mfd. choke tuning condenser and a 4 Mfd. electrolytic filter condenser. All of these items for the 25 cycle receiver are shown in the parts list.

The description and testing as covered in the No. 7 Service Notes also applies to the No. 7X.

Referring to Fig. 1 it will be noted that in the 60 cycle, No. 7 chassis the filter choke is tuned with a .1 Mfd. condenser. The purpose of this condenser is to tune the choke so as to offer maximum opposition to the 120 cycle ripple component. In the No. 7X chassis a .35 Mfd. condenser is used to tune the choke so as to offer maximum opposition to the 50 cycle ripple component which is present when 25 cycle power is used. Also in the No. 7X chassis there are three 4 Mfd. filter condensers used, while the No. 7, 60 cycle chassis uses two 4 Mfd. units and one 2 Mfd. unit.

The No. 7X, 25 cycle chassis can be operated satisfactorily from a 60 cycle power supply. If there is excessive hum it will be necessary to remove the .35 choke condenser and replace it with a .1 Mfd. choke condenser, Part No. 2927. The reverse is not true, that is, the No. 7, 60 cycle receiver cannot be operated satisfactorily from a 25 cycle power supply.

**MODEL 7
Chassis View
Parts List**

U. S. RADIO & TELEVISION CORP.

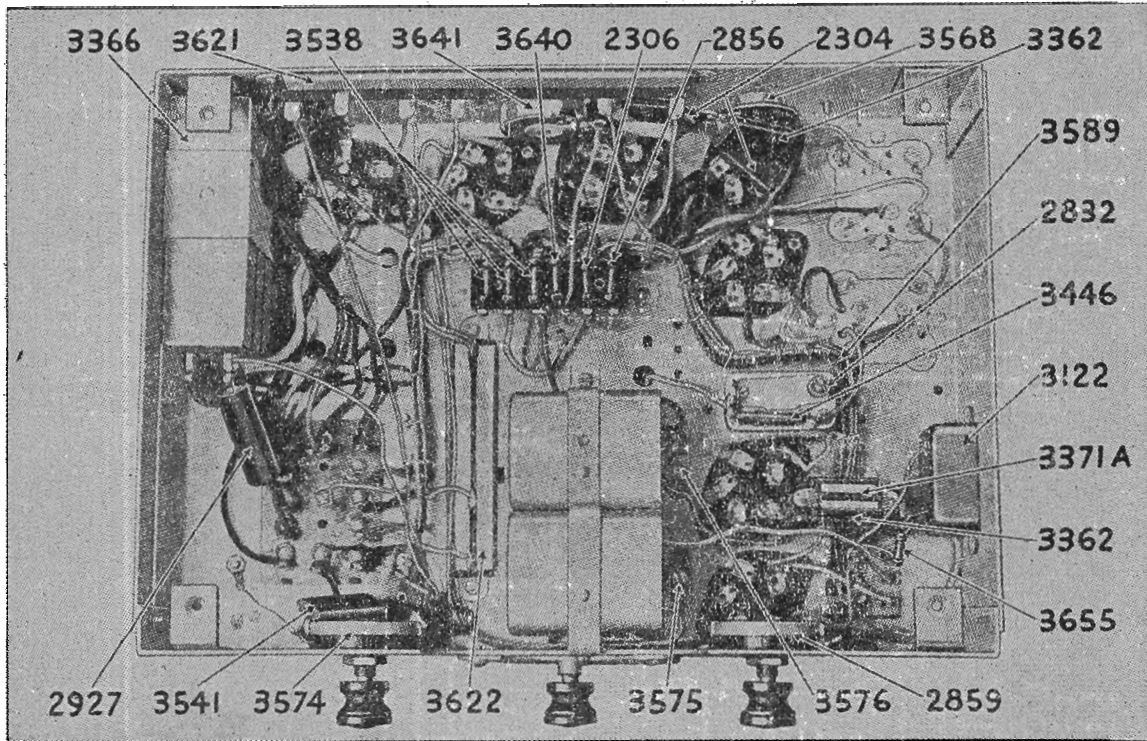

-No. 7 Chassis, Bottom View

No. 7 CHASSIS REPLACEMENT PARTS

Parts orders must be accompanied by serial number and model number of chassis. Order through your distributor.

Part No.	Description	No. Used in Set	List Price Each
2304	.0005 Mfd. By-pass Condensers.....	2	\$.40
2832	Oscillator 600 K.C. Trimmer Condenser.....	1	.40
2927	.1 Mfd. Choke Condenser for 60 Cycle.....	1	.40
3683	.35 Mfd. Choke Condenser for 25 Cycle.....	1	.55
3122	.5 Mfd. By-pass Condenser.....	1	.70
3362	.01 Mfd. Coupling and By-pass Condensers.....	2	.30
3366	4 Mfd. Electrolytic Condenser Unit, 450 Volt.....	2	1.40
3529	2 Mfd. Electrolytic Condenser Unit, 450 Volt.....	1	1.10
3559	Clamp for Electrolytic Condenser Unit.....	1	.10
3446	775 Mmf. Oscillator Condenser.....	1	.45
3541	.04 Mfd. Tone Blender Condenser.....	1	.30
2306	60,000 Ohm Series Resistor, Carbon.....	1	.45
2856	25,000 Ohm Series Resistor, Carbon.....	1	.45
2859	Volume Control 0—500,000 Ohm.....	1	1.40
3574	Tone Blender 0—150,000 Ohm.....	1	1.40
3641	Localizer Resistor 0—200,000 Ohm.....	1	1.20
3371A	3,200 Ohm Biasing Resistor, Wire Wound.....	1	.40
3537	300,000 Ohm Plate Resistor, Carbon.....	1	.40
3538	200,000 Ohm Plate and Series Resistors, Carbon.....	3	.40
3621	3315 Ohm Voltage Divider Resistor, Wire Wound.....	1	1.10
3622	4300 Ohm Voltage Divider Resistor, Wire Wound.....	1	.70
3640	120,000 Ohm Bias Resistor, Carbon.....	1	.40
3655	3,000 Ohm R.F. Resistor, Carbon.....	1	.40
3575	Antenna Transformer.....	1	1.00
3576	1st Detector Transformer.....	1	.60
3562	Can for Antenna and 1st Detector Transformer.....	1	.65
E.P.	Escutcheon Plate (Specify Model No. of Receiver).....	1	.75
3568	Detector Plate Choke Assembly complete.....	1	.60
3680	R.F. Choke Coil, 5 uh.....	1	.10
3589	Harness Cable.....	1	1.00

MODEL 8 Series
Socket - Voltage
Condenser Data

U. S. RADIO & TELEVISION CORP.

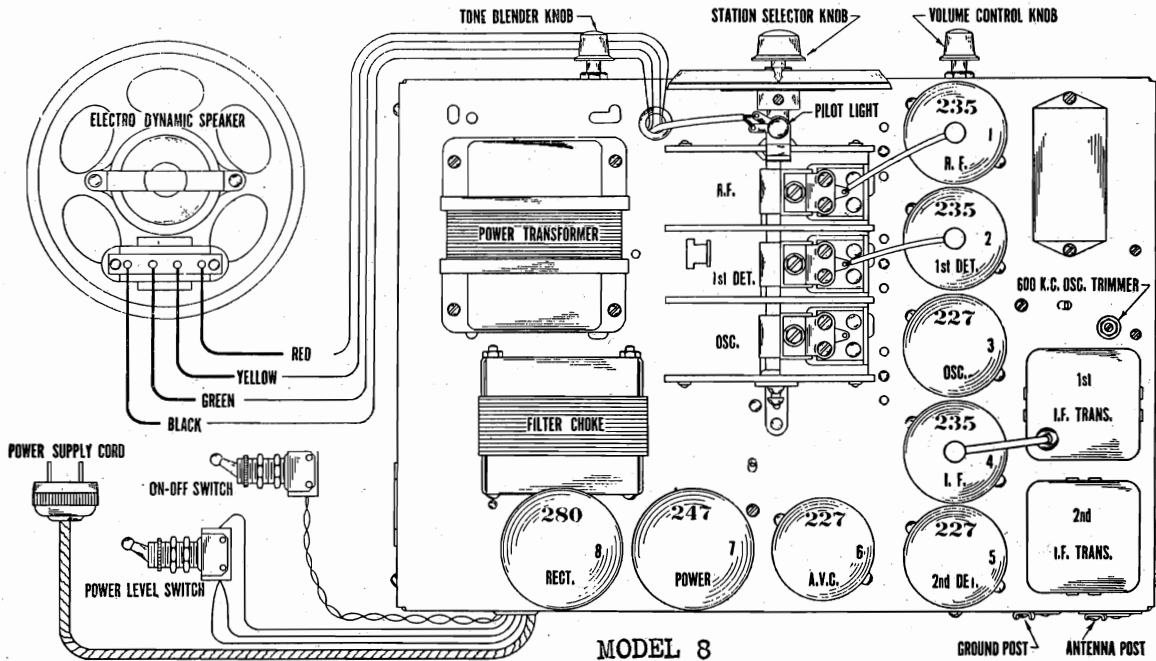

Top View of Chassis Showing Tube Location and Speaker Connections

MODEL 8					
Tube	A Volts	B Volts	V Volts	Scr. Volts	Plt. Crnt.
RF	2.3	190	2.3 ¹	68.	3.8
1st Det	2.3	190	6.5	70.	2.0
Osc.	2.3	80	15-50 ²		4.7
IF	2.3	190	2.3 ¹	68.	3.6
2nd Det	2.3	150	20.		.4
AVC	2.3	65 ³	40. ¹		0.
Power	2.35	260	20 ⁵	280.	32.
Rect.	5.				41. ⁶

¹ Across 250 ohm series resistor
² Governed by setting of tuning condenser
³ Across 1000 and 1200 ohm sections of shunt resist
⁴ Across two 600 ohm sections of shunt resistor
⁵ Across 550 ohm series resistor
⁶ Per Anode.

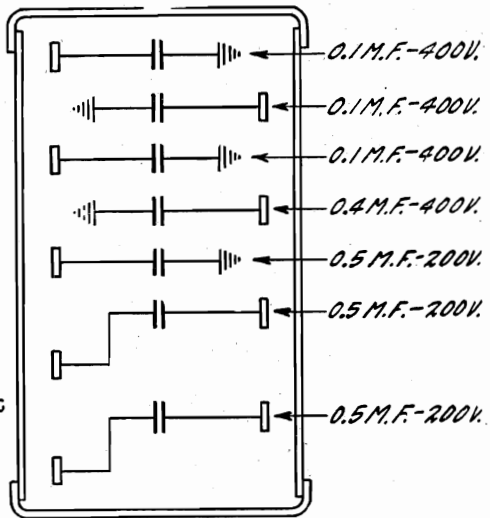

The No. 8X chassis is the same as the No. 8 except that it is intended for use on 25 cycle lines. The major difference is found in the power transformer and in the use of an untuned filter system. The .06 mfd condenser shown in the model 8 schematic connected across the filter choke is not employed in 8X. The 8X chassis may be used on a 60 cycle line. If the hum is bad, add the .06 mfd condenser.

For special service data see Heterodyne and Motorboating notes and RF, Oscillator and IF trimmer condenser data

U. S. RADIO & TELEVISION CORP.

MODEL 8 Series
Chassis View
Parts List

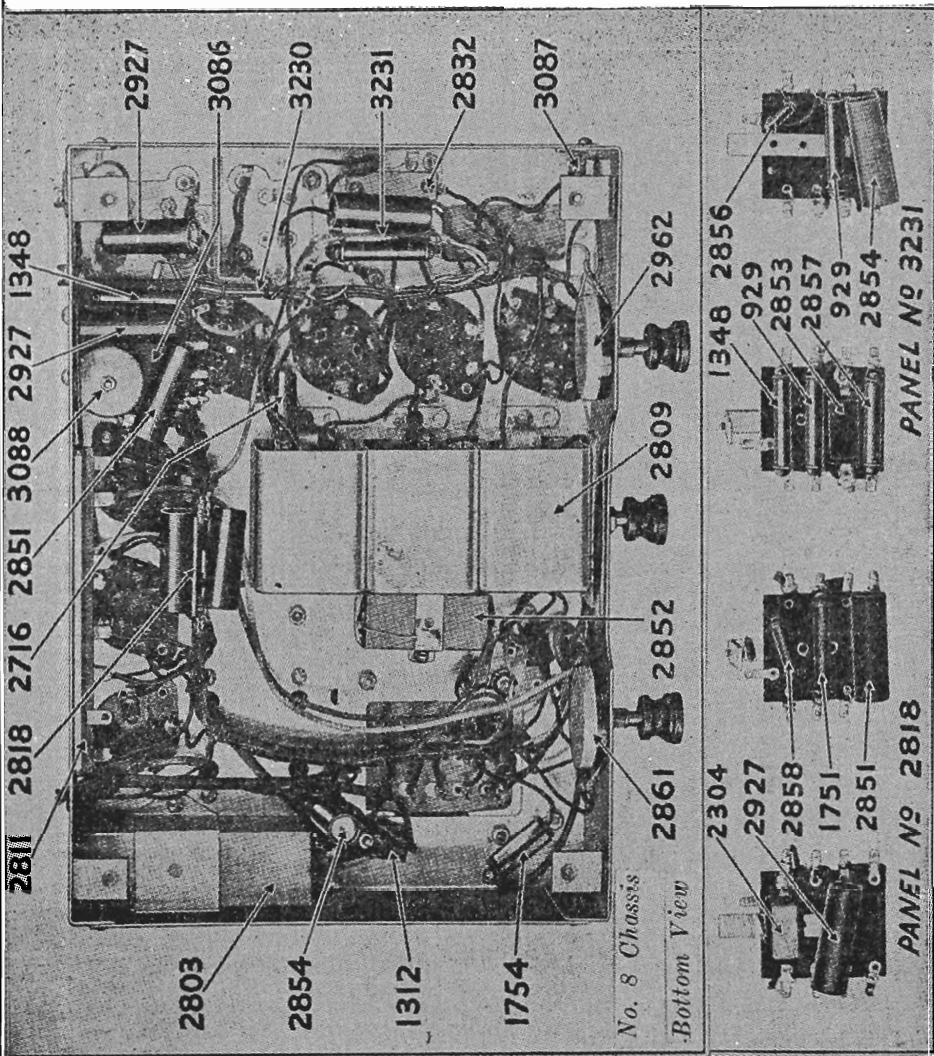

-Resistor and Condenser Panels No. 8 Chassis

NO. 8 CHASSIS. REPLACEMENT PARTS

Part No.	Description
929	50,000 Ohm Bias and Series Resistors, Carbon.
1348	100,000 Ohm. Bias and Series Resistors, Carbon.
1751	200,000 Ohm Series Resistor, Carbon.
1754	250 Ohm Bias Resistor, Wire Wound.
2811	4450 Ohm Voltage Divider Resistor.
2856	25,000 Ohm Series Resistor, Carbon.
2857	10,000 Ohm Series Resistor, Carbon.
2858	1 Megohm Grid Resistor, Carbon.
2861	Tone Blender 0-150,000 Ohm.
2962	Volume Control 0-1 Megohm.
3087	3,000 Ohm Bias Resistor, Wire Wound.
2304	.0005 Mfd. Coupling and By-Pass Condensers.
2716	.01 Mfd. Oscillator Condenser.
2808	8 Mfd. Electrolytic Condenser Unit, 450 Volts.
2810	Clamp for 2803 Electrolytic Condenser Units.
2852	8 Mfd. Electrolytic Condenser Unit, 150 Volts.
2849	Clamp for 2852 Electrolytic Condenser Unit.
2808	7-Section Condenser Block.
2832	Oscillator 600 K.C. Trimmer Condenser.
2851	.04 Mfd. Coupling and By-pass Condensers.
2853	.550 Mfd. Oscillator Condenser.
2854	.06 Mfd. Choke and By-Pass Condensers.
2923	3-Gang Variable Condenser Assembly Complete Less Drive
2927	1 Mfd. By-pass Condensers.
115	Pilot Light Lamp, 25 Volts.
2946	Attachment Cord and Plug.
861	Ground Binding Post.
678	Antenna Binding Post Assembly.
2333	Tube Socket-280.
701	Tube Socket-287.
703	Tube Socket-247.
2757	Tube Socket-235.
2805	Terminal Insulator.
1312	On-Off Escutcheon Plate.
1436	Power Level Escutcheon Plate.
2948	Escutcheon Plate.
2881	Antenna Transformer.
2813	1st Detector Transformer.
2814	Oscillator Transformer.
2815	R.F. Transformer Shield Can.
2809	Tube Shield
2824	Tube Shield Wing Nuts.
2879	Power Transformer, 60 Cycle, 115 Volt.
2783	Power Transformer, 25 Cycle, 115 Volt.
3084	1st Intermediate Assembly Complete with Can.
2830	2nd Intermediate Assembly Complete with Can.
2831	Adjusting Screw for Intermediate Condenser.
2842	Special Hex Nut for Intermediate Condenser.
2850	On-Off Switch and Leads.
2932	Power Level Switch and Leads.
2936	Drive Assembly Complete with Dial Chart.
2883	Dial Chart Assembly.
2902	Pointer Tension Spring for Drive.
2895	Chassis End Plates.
2847	

Sold In Matched Sets of Three

- 2932 Filter Choke Assembly
- 2818 Resistor and Condenser Panel Assembly Complete.
- 3231 Resistor and Condenser Panel Assembly Complete.
- 3086 2nd Detector Panel Assembly Complete with Socket.
- 1766 Detector Plate Choke Coil
- 3088 Shield Can for Detector Plate Choke Coil
- 2801 8" D.C. Electrodynamc Speaker for No. 8 Chassis.
- 3294 Field Coil for Speaker
- 3298 Transformer for Speaker
- 2608 Terminal Strip for Speaker
- 3295 Terminal Strip Cover for Speaker
- 3296 Head Assembly Complete including Cone, Housing, Voice Coil, Spider and Pot Magnet Front Piece for Speaker.
- 3297 Pot Magnet Back Piece for Speaker

U. S. RADIO & TELEVISION CORP.

MODEL 10
Voltage
Socket

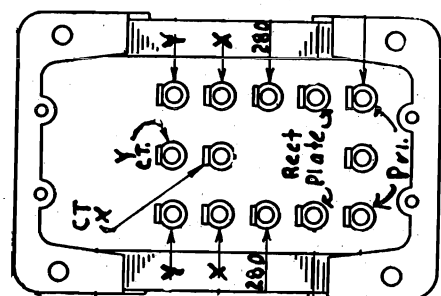
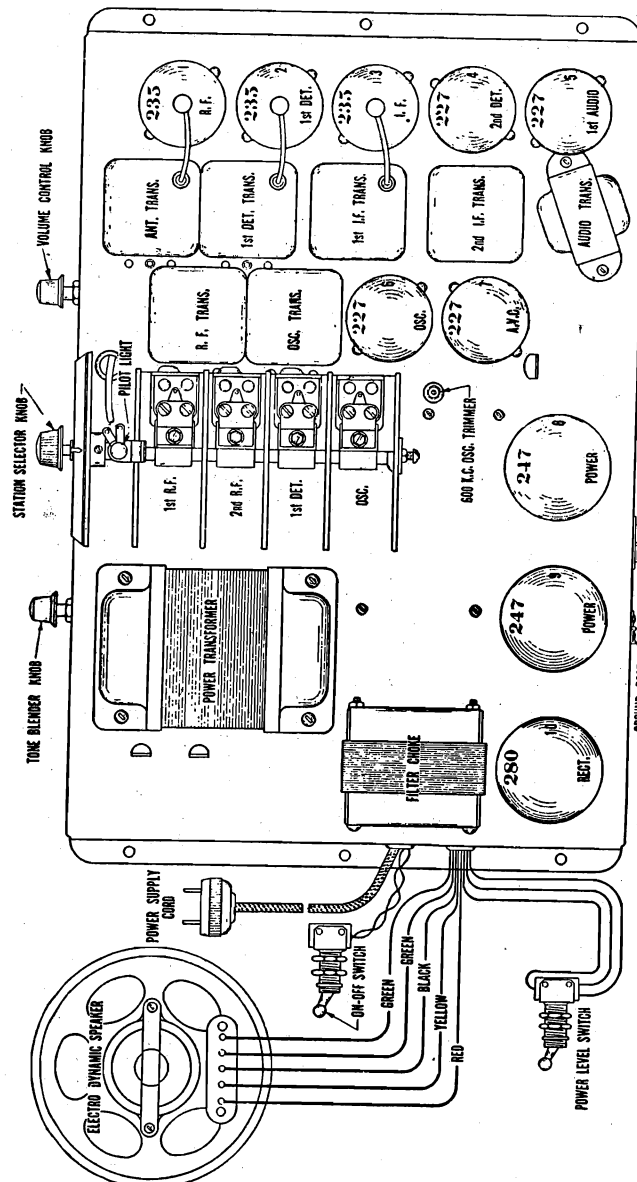

MODEL 10 PENTODE SUPERHETERODYNE

Tube	A Volts	B Volts	C Volts	Scr. Volts	Plt. Crnt.
RF	2.3	175.	2.31	65	4.0
1st Det	2.3	185.	7.0	69	2.0
IP	2.3	175	2.31	65	4.0
2nd Det	2.3	115	12.		4
1st AF	2.3	145	11. 2		4.6
Osc.	2.3	83	15-35 ³		4.2
AVC	2.3	89 ⁴	20. 5		0.
Power	2.35	255	18.5	265	21.
Power	2.35	255	18.5	265	21. 6
Rect.	4.9				45.

1 Across 250 ohm series resistor
 2 Across 2500 ohm series resistor
 3 Governed by setting of tuning condenser
 4 Across 1000 and 1800 ohm sections of shunt resistor.
 5 Across 600 ohm section of shunt resistor
 6 Per Anode.

Heterodyne Whistle

A heterodyne whistle in the Super-heterodyne Receiver may be caused by a beat between a harmonic of the I.F. signal and an R.F. signal.
 A whistle can be brought about at 786 K.C., 1048 K.C. or 1310 K.C. if the 2nd detector filter choke is shorted or if the antenna lead is under this choke. The above mentioned frequencies are harmonics of the intermediate frequency of 262 K.C. and as they fall within the broadcast band can cause an audible beat with an R.F. signal.
 A whistle can also be brought about between 540 and 600 K.C. if the I.F. tuning condensers are adjusted at too high a frequency rather than at 262 K.C. If they are adjusted, for example, at 280 K.C. the second harmonic is 560 K.C. which falls within the broadcast band and can beat with an R.F. signal.

Blocking or Motorboating

Blocking or motorboating in the No. 10 chassis may be due to an open grid in the 1st detector or I.F. stage. Check these circuits if motorboating is experienced. Motorboating may also be caused if the 10,000 ohm series resistor in the LF. and R.F. screen line is shorted.
 If the A.V.C. tube is not operating properly motorboating may result. Try out a new tube and check the A.V.C. circuit. Blocking or motorboating may also be due to open R.F. and I.F. screen by-pass condenser and to various other defective filter and by-pass condensers.

**MODEL 10
Chassis View
Parts List**

U. S. RADIO & TELEVISION CORP.

NO. 10 CHASSIS

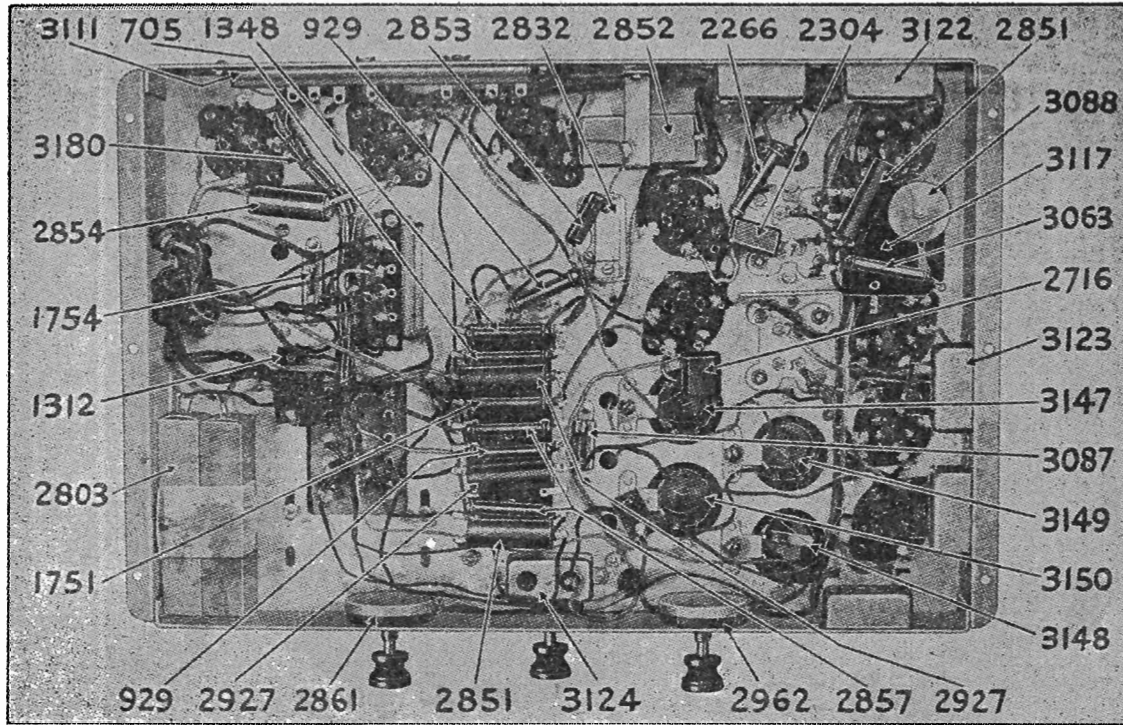

Bottom View No. 10 Chassis

Part No. Description No. 10 Chassis

705	25,000 Ohm Series Resistor, Carbon.....
929	50,000 Ohm Bias and Series Resistor, Carbon.....
1348	100,000 Ohm Series Resistor, Carbon.....
1751	200,000 Ohm Series Resistor, Carbon.....
1754	250 Ohm Bias Resistor, Wire Wound.....
2266	1 Megohm Resistor.....
2857	10,000 Ohm Series Resistor, Carbon.....
2861	Tone Blender 0—150,000 Ohm.....
2962	Volume Control 0—1 Megohm.....
3063	30,000 Ohm Bias Resistor, Carbon.....
3087	3,000 Ohm Bias Resistor, Wire Wound.....
3111	6325 Ohm Voltage Divider Resistor.....
2304	.0005 Mfd. Coupling and By-Pass Condensers.....
2716	.01 Mfd. Oscillator Condenser.....
2719	8 Mfd. Electrolytic Condenser Unit, 275 Volt.....
2803	8 Mfd. Electrolytic Condenser Unit, 450 Volt.....
3112	Clamp for 2803 Electrolytic Condenser Units.....
2852	8 Mfd. Electrolytic Condenser Unit, 150 Volt.....
3113	Clamp for 2852 Electrolytic Condenser Unit.....
3190	Auxiliary Bracket for 2852 Electrolytic Condenser Unit.....
2832	Oscillator 600 K.C. Trimmer Condenser.....
2851	.04 Mfd. Coupling and Filter Condensers.....
2853	550 Mmfd. Oscillator Condenser.....
2854	.06 Mfd. Choke Condenser.....
2927	1 Mfd. By-Pass Condensers, 200 Volts.....
3122	.5 Mfd. By-Pass Condensers, 200 Volts.....
3123	Dual J.—.05 Mfd. Condenser, 200 Volt.....
3124	1 Mfd. By-Pass Condenser, 400 Volt.....
3114	Resistor and Condenser Panel Assembly, Complete.....
1766	Detector Plate Choke Coil.....
3088	Shield Can for Detector Plate Choke Coil.....
3117	2nd Detector Panel Assembly, Complete with Socket.....
678	Ground Binding Post.....
2333	Antenna Binding Post Assembly.....
1312	Terminal Insulators.....
3148	Antenna Transformer.....
3150	R.F. Transformer.....
3149	1st Detector Transformer.....
3147	Oscillator Transformer.....
3180	Chassis Harness.....
701	Tube Socket—280.....
703	Tube Socket—227.....
2757	Tube Socket—247.....
2805	Tube Socket—235.....
861	Attachment Cord and Plug.....
1436	On-Off Escutcheon Plate.....
2948	Power Level Escutcheon Plate.....
2882	Escutcheon Plate.....
2876	Walnut Knobs.....
2392	On-Off Switch and Leads.....
2936	Power Level Switch and Leads.....
3175	4-Gang Variable Condenser Assembly Complete less Drive and Meter.....
3121	Variable Condenser Shield.....
2883	Drive Assembly Complete with Dial Chart.....
2902	Dial Chart Assembly.....
2895	Pointer Tension Spring for Drive.....
2911	Tuning Meter.....
3081	Bracket for Tuning Meter.....
3181	Grid Cap Assembly.....
2830	1st Intermediate Assembly Complete with Can.....
2831	2nd Intermediate Assembly Complete with Can.....
2842	Adjusting Screw for Intermediate Condensers.....
2850	Special Hex Nuts for Intermediate Condensers.....
2912	Power Transformer, 60 Cycles, 115 Volt.....
3169	Power Transformer, 25 Cycles, 115 Volt.....
2932	Filter Choke Assembly.....
3100	Audio Transformer.....

Sold in Matched Sets of Four

MODEL 10-C

Chassis 1000,1001

U. S. RADIO & TELEVISION CORP.

Voltage

Notes

SPEAKERS

The output of the receiver is fed into the primary of the transformer for the speakers. In the chassis No. 1001 matched speakers are used. Both are D.C. baffle mounting electrodynamic speakers—one having a cone diameter of 10 inches and the other an 8 inch cone.

The fields of both speakers are energized by the power system and are a part of the total resistance shunted across the power system from which the required voltages are obtained. The 5000 ohm field coil is a component part of the 10 inch speaker—Part No. 3846—as is the output transformer. The 5000 ohm field coil is above ground potential whereas the 2000 ohm field coil is below ground potential, as can be seen by referring to Fig. 1. The ground potential side of each field coil winding is grounded to the speaker frame. The voice coil of each speaker is connected in parallel across the secondary winding of the output transformer.

CAUTION—Do not use any other type of speakers with the No. 1001 chassis than the two supplied with it. It can readily be appreciated from the above that the speakers are especially designed for this chassis.

An open or shorted voice coil in either of the speakers will cause poor audio quality. Check voice coil tips (blue and white) at speaker terminal strip for good electrical contact. A shorted 2000 ohm speaker coil will cause distortion as will also an open 5000 ohm speaker coil, and in both cases, the needle of the tuning meter will swing to the extreme left.

The polarity of the leads connecting the voice coils of the two speakers in parallel should be checked. If the blue and white wires making these connections are reversed, distortion and motorboating will result, because one cone is moving out while the other is moving in, and vice versa.

ual. If one of the pilot light terminals is grounded, the second audio bias will be shorted out and there will be distortion present.

If the 2000 ohm field coil of the No. 3847 electrodynamic speaker is open lack of volume will be experienced and will be evidenced by the needle of the visual tuning meter, swinging almost to the extreme right. The same will be true if the 5000 ohm field of the No. 3846 electrodynamic speaker is open. However, in this case the needle of the tuning meter will swing to the extreme left. The yellow wire connecting the speakers to the chassis ground should be checked for good electrical connection. If this lead is making poor contact loss of volume will result. The tuning meter will register approximately a 50% reduction in swing at no signal.

MICROPHONIC HOWL

The No. 1001 Chassis is mounted in the console cabinet on sponge rubber washers to prevent any microphonic action that might otherwise arise due to vibrations set up between the speaker and tube elements.

At the time of installation of the receiver the two bolts, one at the center of the flange at each end of the chassis should be removed. These bolts are used to securely anchor the chassis to the cabinet shelf and are intended only for shipping purposes. If they are not removed vibrations of the speaker will be transmitted to the tube elements and a microphonic howl may result.

This howl may also manifest itself when the chassis and speaker are being tested on a service bench thus making it very difficult to service the unit. The chassis or speaker should be cushioned as a preventive.

Type of Tube	Position of Tube	Function	"A" Volts	"B" Volts	Control "C" Volts	Screen Volts	Screen Current MA	Cathode Volts	Plate MA	Grid Test MA
235	1	R.F.	2.2	160	2.8 (1)	60	.4	0.	2.7	6.1
235	2	1st Det.	2.25	160	6.5 (1)	55	.3	7.	1.8	2.4
235	3	I.F.	2.2	160	2.8 (1)	60	.4	0.	2.7	6.1
227	4	2nd Det.	2.3	105	6. (2)			5.5	.2	.3
235	5	1st Audio	2.3	125	13. (2)			7.	2.8	3.0
227	6	Osc.	2.35	110	11-28(3)			21.	3.4	3.5
227	7	A.V.C.	2.3	55(4)	21. (5)			1.5	0.	0.
247	8	Power	2.3	250	20. (6)	258	4.6		20.	26.
247	9	Power	2.35	250	20. (6)	258	4.6		20.	26.
280	10	Rect.	5.0						50.	

(1) Measured across 350 ohm bias resistor.
 (2) Measured across 3000 ohm bias resistor. B. to Cathode.
 (3) Measured across 500 M ohm osc. bias resistor. Bias voltage varies from 11 to 28 between 1500 and 550 K.C. settings of tuning condenser.
 (4) Measured from B. to A.V.C. plate.
 (5) Measured from B. to A.V.C. Cathode.
 (6) Measured across 425 ohm bias resistor. B. to "Y" filament.

U. S. RADIO & TELEVISION CORP.

MODEL 10-C
 Chassis 1000, 1001
 Bottom View
 Notes

No. 1000X AND No. 1001X CHASSIS

Chassis No. 1000X and No. 1001X are almost identical in construction with chassis No. 1000 and No. 1001 except that they are designed for 25 cycle, 115 volt A.C. operation. The parts used in the 60 cycle chassis are also used in those chassis designed for 25 cycle operation with the exception of the power transformer and .06 Mfd. filter choke tuning condenser. The correct power transformer for the 25 cycle chassis as well as the correct filter choke tuning condenser are shown in the Parts Price List.

The description and testing as covered in the service notes for the 60 cycle chassis also applies to the 25 cycle chassis.

The 25 cycle chassis can be operated satisfactorily from a 60 cycle power supply. However, there may be excessive hum in which case it will be necessary to change the No. 1375 .45 Mfd. choke condenser to a No. 2854 .06 Mfd. condenser. The reverse is not true, that is, the 60 cycle chassis cannot be operated satisfactorily from a 25 cycle power supply.

SUPPLEMENTARY NOTES FOR No. 1000 CHASSIS

The No. 1000 and No. 1001 Chassis are identically alike as regards the schematic circuit and the electrical constants. Referring to the schematic wiring diagram it will be noted the visual tuning meter is not drawn in solid lines but instead dotted lines are used. The significance of the dotted lines is to illustrate that the tuning meter is a component part of chassis No. 1001 whereas in chassis No. 1000 the meter is omitted the electrical circuit being completed by the joining of the two leads ordinarily connected to the meter leads on the 1001 chassis.

electrodynamic speaker whereas the No. 1000 chassis utilizes two 8 inch speakers. The speakers for their respective chassis carry entirely different part numbers and these dissimilarities including other changes in a few of the parts for each chassis are enumerated in the parts list to follow.

The electrical constants of the dual speakers used with each chassis are alike, however, the 1001 chassis has one 8 inch and one 10 inch

It will be noted a number of the speaker parts for the No. 1001 chassis are interchangeable with the component parts of the speakers for the No. 1000 chassis and therefore it has not been thought necessary to make a repetition of these parts numbers in the accompanying list of the changes in parts for the No. 1000 chassis.

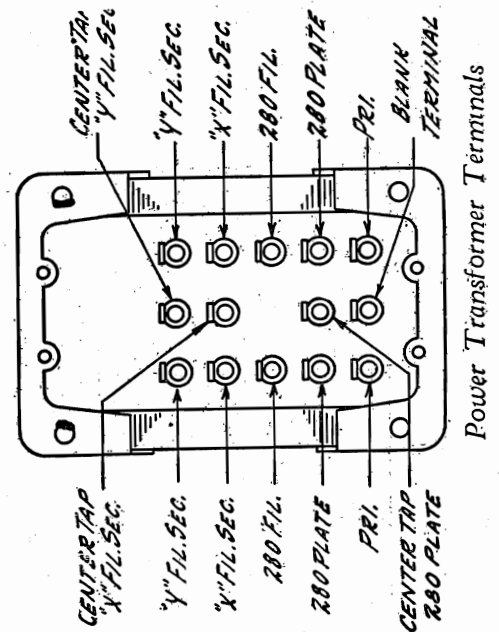
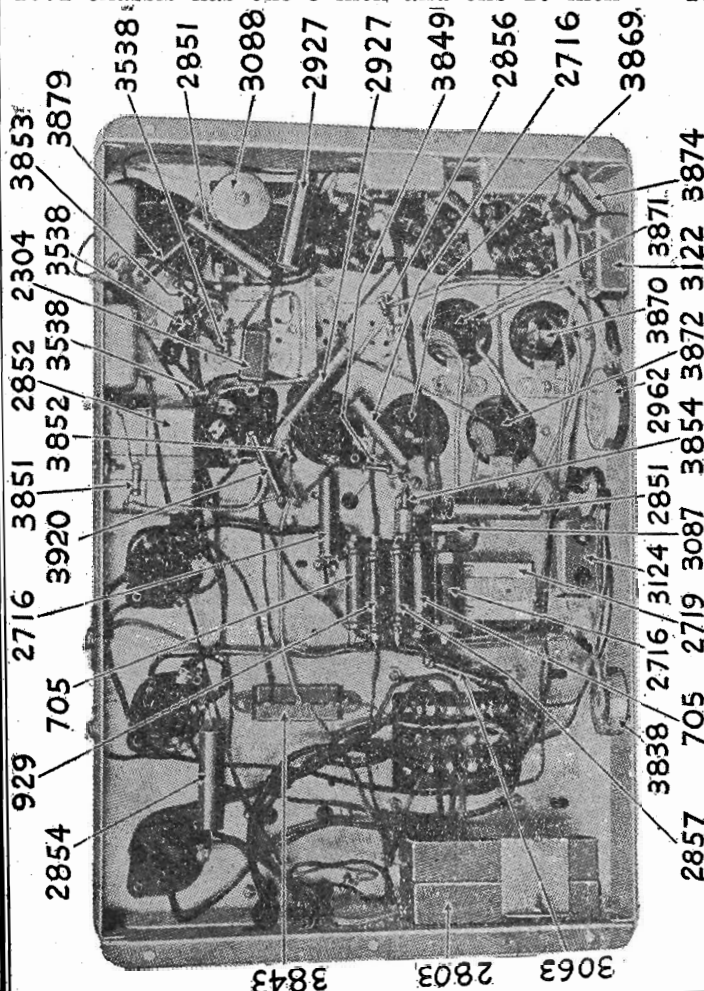

MODEL 10-C
Chassis 1000,1001
Parts List

U. S. RADIO & TELEVISION CORP.

Part No.	Description	No. Used in Set	List Price Each
3151	Pilot Light Bracket with Leads	1	.30
3178	Shield Can for R.F. and 1st Detector Transformer	1	.75
3179	Shield Can for Oscillator and R.F. Transformer	1	.75
3181	Grid Cap with Lead	2	.05
3884	Power Transformer, 60 Cycle, 115 Volt	1	9.00
3846	10 inch D.C. Electrodynamic Speaker with Input Transformer	1	10.00
3847	8 inch D.C. Electrodynamic Speaker less Input Transformer	1	6.00
3860	Tuning Meter	1	3.50
3862	Speaker Cable	1	.65
3873	Grid Cap with Lead for 1st Audio 235	1	.05
3884	Power Transformer, 25 Cycle, 115 Volt	1	11.00
3884	4 Gang Variable Condenser Complete less Drive and Meter	1	10.00
4010	Transformer for 3846 and 3844 Speakers	1	3.00
4011	Field Coil for 3846 and 3844 Speakers—5000 Ohm	1	3.00
4012	Terminal Strip for 3846 and 3844 Speakers	1	.50
4013	Head Assembly for 3847, 3844 and 3845 Speakers	1	3.50
4015	Terminal Strip for 3847 and 3845 Speakers	1	.50
4016	Terminal Strip Cover for 3846 Speaker	1	.50
4017	Terminal Strip Cover for 3847, 3844 and 3845 Speakers	1	.50
4020	Head Assembly for 3846 Speaker	1	3.75
4021	Field Coil for 3847 Speaker, 2000 Ohm	1	2.75

No. 1000 CHASSIS REPLACEMENT PARTS
(SUPPLEMENTING No. 1001 PARTS LIST)

The following parts are used in addition to the parts listed for the No. 1001 Chassis:

Part No.	Description	No. Used in Set	List Price Each
3408	Escutcheon Plate, U. S. APEX	1	.75
3789	Volume Control, 0-1 Megohm	1	1.40
3837	Tone Blender Rheostat, 0-200,000 Ohm	1	1.40
3844	8" D.C. Electrodynamic Speaker with Input Transformer	1	8.50
3845	8" D.C. Electrodynamic Speaker less Input Transformer	1	6.00
3867	Drive Assembly Complete with Dial Chart less Pilot Light	1	1.20
3873	4 Gang Variable Condenser Assembly	1	10.00
4014	Field Coil for 3845 Speaker—2,000 Ohm	1	3.00

The following parts listed for the No. 1001 Chassis are not used in the No. 1000 Chassis:

2888	Escutcheon Plate, U. S. APEX	1	.75
2883	Drive Assembly Complete with Dial Chart	1	1.20
2895	Pointer Tension Spring for Drive	1	.15
2902	Dial Chart Assembly	1	.20
2962	Volume Control, 0-1 Megohm	1	1.40
3081	Bracket for Tuning Meter	1	.10
3151	Pilot Light Bracket with Leads	1	.30
3838	Tone Blender Rheostat, 0-200,000 Ohm	1	1.40
3846	10" D.C. Electrodynamic Speaker with Input Transformer	1	10.00
3847	8" D.C. Electrodynamic Speaker less Input Transformer	1	6.00
3860	Tuning Meter	1	3.50
3884	4 Gang Variable Condenser Assembly Complete less Drive and Meter	1	10.00
4016	Terminal Strip Cover for 3846 Speaker	1	.50
4020	Head Assembly Complete for 3846 Speaker	1	3.75
4021	Field Coil for 3847 Speaker—2,000 Ohm	1	2.75

No. 1001 CHASSIS REPLACEMENT PARTS

Part No.	Description	No. Used in Set	List Price Each
678	Ground Binding Post	1	.15
709	Resistor, 25,000 Ohm, Carbon, 1 Watt	2	.50
925	Resistor, 50,000 Ohm, Carbon, 1 Watt	1	.45
1375	Choke Condenser .45 Mfd, for 25 Cycle	1	1.00
1765	Detector Plate Choke Coil	1	.60
2304	Condenser, .0005 Mfd Coupling and Bypass	3	.40
2333	Antenna Binding Post	1	.20
2716	Condenser, .01 Mfd, 400 Volt	2	.45
2719	Dry Electrolytic Condenser, 8 Mfd, 275 Volt	1	5.00
2803	Dry Electrolytic Condenser, 8 Mfd, 450 Volt	2	2.00
2851	Condenser, .04 Mfd, 400 Volt	2	.40
2852	Dry Electrolytic Condenser, 8 Mfd, 150 Volt	2	1.00
2854	Condenser, .06 Mfd, 400 Volt	1	.40
2856	Resistor, 25,000 Ohm, 1 Watt	1	.45
2857	Resistor, 10,000 Ohm, Carbon, 1 Watt	1	.45
2927	Condenser, .1 Mfd, 200 Volt	2	.40
2962	Volume Control, 0-1 Megohm	1	1.40
3063	Resistor, 30,000 Ohm, Carbon, 1 Watt	1	.40
3080	Bracket for 3884 Condenser	1	.05
3087	Resistor, 3000 Ohm, Candohm	1	.35
3088	Shield Can for Detector Plate Choke Coil	1	.15
3112	Clamp for 2803 Electrolytic Condenser	1	.05
3113	Clamp for 2852 Electrolytic Condensers	1	.05
3119	Intermediate Frequency Shield	1	.05
3122	Condenser, .5 Mfd, 200 Volts	5	.70
3124	Condenser, .1 Mfd, 400 Volts	1	.65
3358	Bakelite Terminal Insulator	3	.05
3538	Resistor, 200,000 Ohm, Carbon, 1 Watt	2	.40
3838	Tone Control, 0-200,000 Ohm	1	1.40
3843	Resistor, 425-3000 Ohm, Candohm	1	.50
3849	Resistor, 500,000 Ohm, Carbon, 1 Watt	1	.40
3851	Resistor, 33,000 Ohm, Carbon, .1 Watt	1	.40
3852	Resistor, 10,000 Ohm, Carbon, 1 Watt	1	.40
3853	Resistor, 50,000 Ohm, Carbon, 1 Watt	1	.40
3854	Condenser, 540 Mmfd	1	.50
3866A	Resistor and Condenser Panel Assembly	1	2.50
3865	2nd Detector Panel Assembly Complete with Socket	1	2.50
3869	Oscillator Transformer	1	.60
3870	Antenna Transformer	1	1.00
3871	1st Detector Transformer	1	.60
3872	R.F. Transformer	1	.60
3874	Resistor, 350 Ohm, Candohm	1	.30
3879	Resistor, 100,000 Ohm, 1 Watt	1	.40
3920	Resistor, 300,000 Ohm, 1 Watt	1	.40
3115	Pilot Light Lamp	1	.25
701	Tube Socket—250	1	.35
861	Tube Socket—227	3	.35
1436	Attachment Cord and Plug	1	1.00
2392	On-Off Escutcheon Plate	1	1.00
2757	On-Off Switch with Leads	2	.35
2805	Tube Socket—247	2	.35
2830	Tube Socket—235	4	.35
2831	2nd Intermediate Transformer Assembly Complete with Can	1	1.80
2842	Adjusting Screw for Intermediate Assemblies	4	1.00
2860	Special Hex Nuts for Intermediate Condensers	4	.03
2876	Walnut Knobs	3	.75
2882	Escutcheon Plate, U. S. APEX	1	.75
2883	Drive Assembly Complete with Dial Chart	1	1.20
2895	Pointer Tension Spring for Drive	1	.15
2902	Dial Chart Assembly	1	.20
3081	Bracket for Tuning Meter	1	2.70
3100	Audio Transformer	1	1.10
3108	Tube Shield	1	3.00
3121	Variable Condenser Shield	1	.40

MODEL 20
Voltage - Data

U. S. RADIO & TELEVISION CORP.

No. 20 CHASSIS—VOLTAGES AT SOCKETS—VOLUME CONTROL AT MAXIMUM LINE VOLTAGE. 115—PLUG IN SOCKET OF RECEIVER—TUBE IN TEST SET

Type of Tube	Position of Tube	Function	"A" Volts	"B" Volts	Control Grid "C" Volts	Screen Volts	Screen Current MA	Cathode Volts	Plate MA	Grid Test MA
224	1	1st Radio	2.5	196	2.2	85	1.4	2.2	5.	7.1
224	2	Detector	2.5	95 ⁽¹⁾	2.3 ⁽²⁾	17 ⁽³⁾	.015		.1	.2
171A	3	1st Audio	5.1	191	43. ⁽⁴⁾				18.	20.
280	4	Rectifier	5.1						23.	

- (1) Computed value. Reading with voltmeter will be lower.
- (2) This voltage read across 55 ohm section of shunt resistor.
- (3) This voltage read across 935 ohm section of speaker field and 55 ohm section of shunt resistor.
- (4) This voltage read across 935 ohm section of speaker field and 55 ohm section of shunt resistor.

Tuning Condenser Alignment

The tuning condensers are aligned at the factory with oscillators and output meters and the receiver will not normally lose its alignment unless mishandled or tampered with. When the condenser is out of alignment one or more of the stages are not in resonance and the receiver may tune broadly, lack volume at certain parts of the broadcast band, or tune in a signal at two or more points of the dial.

The chassis should be grounded but the antenna disconnected. In case a strong enough signal is not being received from the oscillator, connect a five or six foot length of wire to the antenna post and run it over towards the oscillator.

First set the oscillator for a signal of 1,400 K.C. Then carefully tune to resonance by turning the tuning condenser rotor slowly back and forth until maximum output is obtained. Now adjust the trimmer condensers to resonance. Adjust the volume control until the pointer of the output meter is at about half scale. The oscillator signal should not be too great in intensity as distortion will be introduced. The trimmer condensers are adjusted by raising or lowering the center screw. Turn the screws down until the volume starts to drop. Then adjust the trimmers to resonance, raising or lowering the screws until maximum deflection is obtained. Adjustment may be made with a metal screw driver as the rotor is at ground potential.

An important point to remember in adjusting the trimmer condenser is that the screws should not be turned completely down. If they are screwed in too tightly the capacity of the trimmer

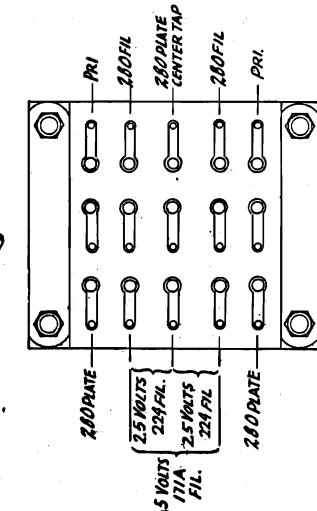
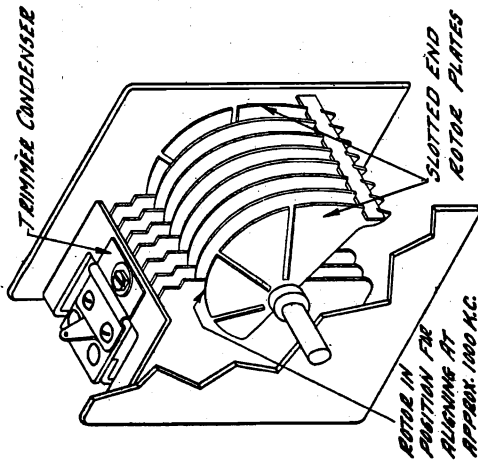

CENTER ROW OF LUGS USED AS WIRING TERMINALS ONLY
Power Transformer Terminals

Electrodynamic Speaker

An especially designed electrodynamic speaker is supplied with the No. 20 chassis. The field of this speaker is energized by the power system of the chassis and is a part of the power system. For that reason no other speaker should be used with the No. 20 chassis than the one supplied with it.

Care should be taken in servicing the No. 20 receiver not to reverse the leads to one of the field sections as the fields will then "buck" and low signal strength will result. The field winding also acts as a filter choke.

condenser which is added to the capacity of the tuning condenser will be so high that the receiver cannot be tuned to a high frequency signal.

After the trimmer condensers have been adjusted at 1,400 K.C., they should not be changed in any way when aligning the tuning condensers at different frequencies as explained below.

Next set the oscillator for a signal of 1,000 K.C. Then turn the tuning condenser rotor carefully until maximum deflection is obtained on output meter. The second slotted section of the rotor will be approximately half way in mesh with the stator as shown in Fig. 3. Bend this section of the two end rotor plates of the first section of the tuning condenser in or out until maximum reading is obtained on the output meter. Follow the same procedure with section two of the tuning condenser. The corresponding slotted section on both ends of any rotor section should be bent in or out about the same amount for each adjustment.

After each material adjustment of a slotted rotor plate section, the tuning or setting of rotor for resonance should be checked. In other words, after every bending turn the tuning knob back and forth until maximum deflection of output meter is obtained before proceeding to make the next adjustment.

Next tune in a signal at 750 K.C. Follow the same procedure. Lastly, tune in a signal at 600 K.C. and again follow the same procedure. The condenser will then be properly aligned.

MODEL 30 Auto Radio

U. S. RADIO & TELEVISION CORP.

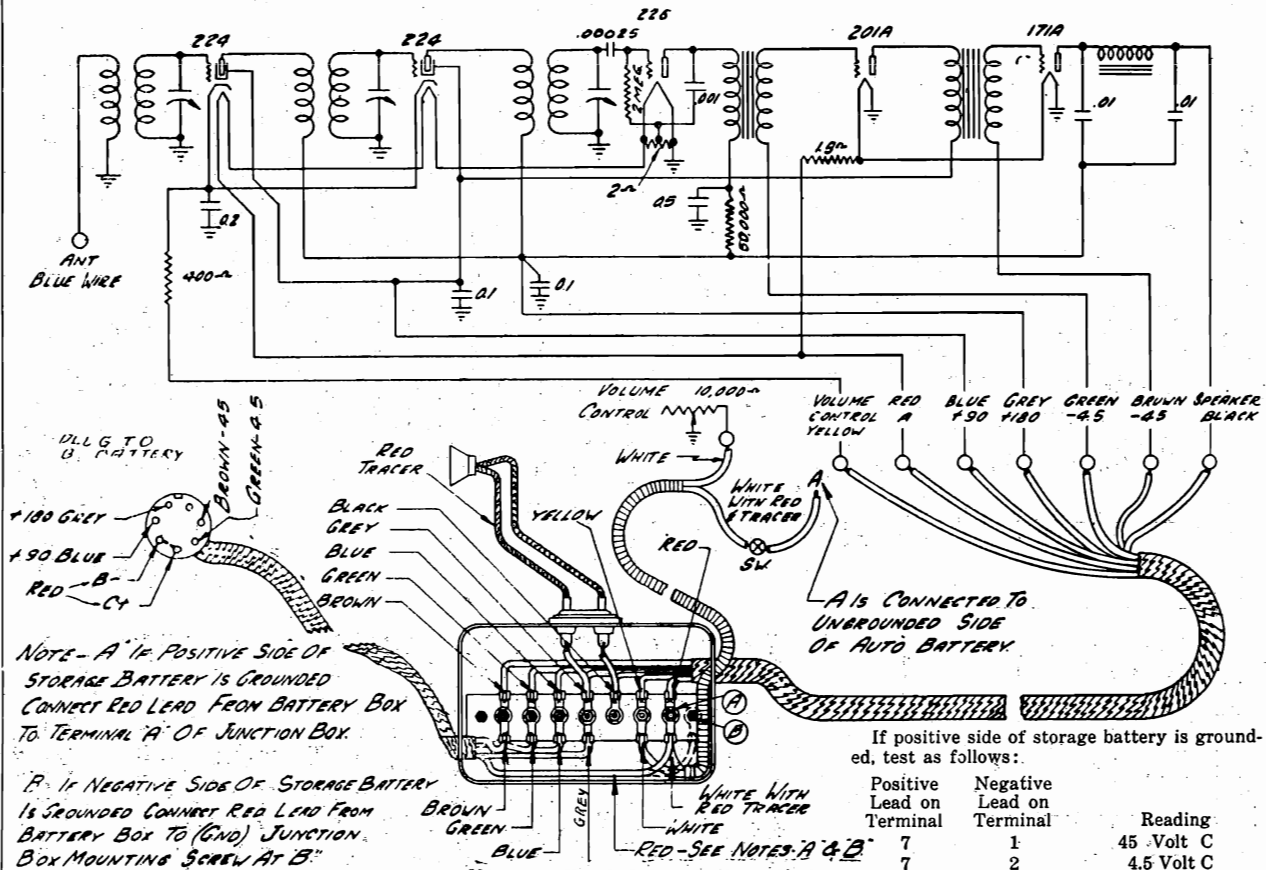

NOTE - A If Positive Side Of Storage Battery Is Grounded Connect Red Lead From Battery Box To Terminal A Of Junction Box.

B If Negative Side Of Storage Battery Is Grounded Connect Red Lead From Battery Box To (GND) Junction Box Mounting Screw At B.

If positive side of storage battery is grounded, test as follows:

Positive Lead on Terminal	Negative Lead on Terminal	Reading
7	1	45 Volt C
7	2	4.5 Volt C
3	7	90 Volt B
4	7	180 Volt B
Ground	7	6 Volt A

If negative side of battery is grounded, test as follows:

Positive Lead on Terminal	Negative Lead on Terminal	Reading
Ground	1	45 Volt C
Ground	2	4.5 Volt C
3	Ground	90 Volt B
4	Ground	180 Volt B
7	Ground	6 Volt A

If any reading is below the lower limits as shown on the following list, a new battery box unit will be required.

Regular Rating	Lower Limit
180 Volt B	140 Volt
90 Volt B	70 Volt
45 Volt C	35 Volt
4.5 Volt C	3.5 Volt

If the "A" battery reading is low, the car storage battery is run down and must be recharged.

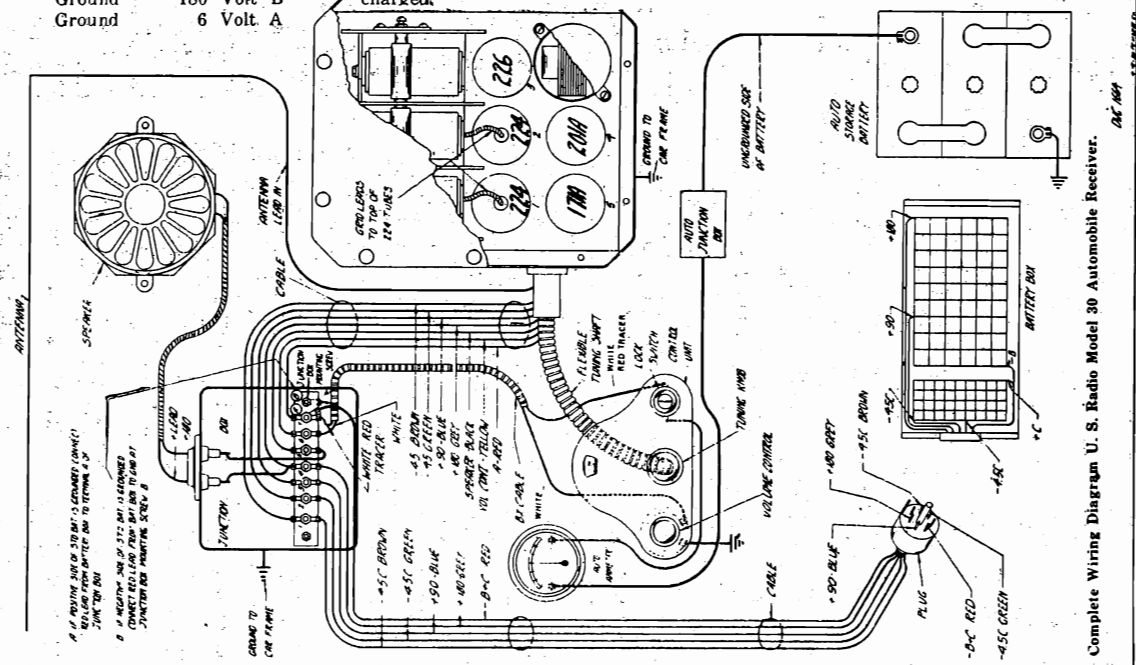

Complete Wiring Diagram U. S. Radio Model 30 Automobile Receiver.

WARE MANUFACTURING CORP.

MODEL T
 MODEL 4 Tube
 MODEL 7 Tube

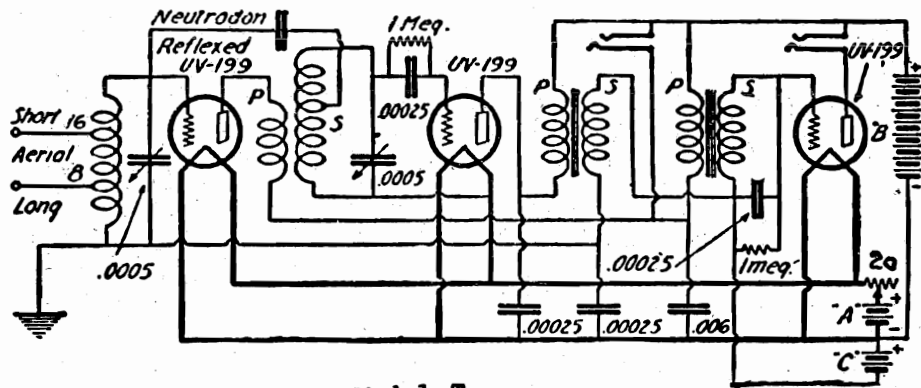

Model T

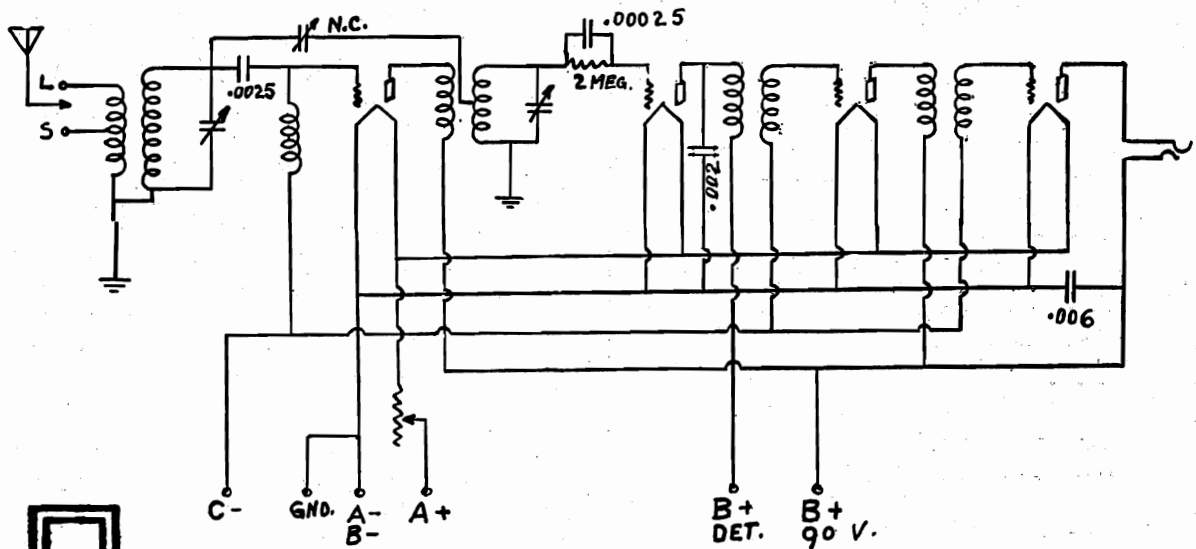

Model 4 Tube "Music Master"

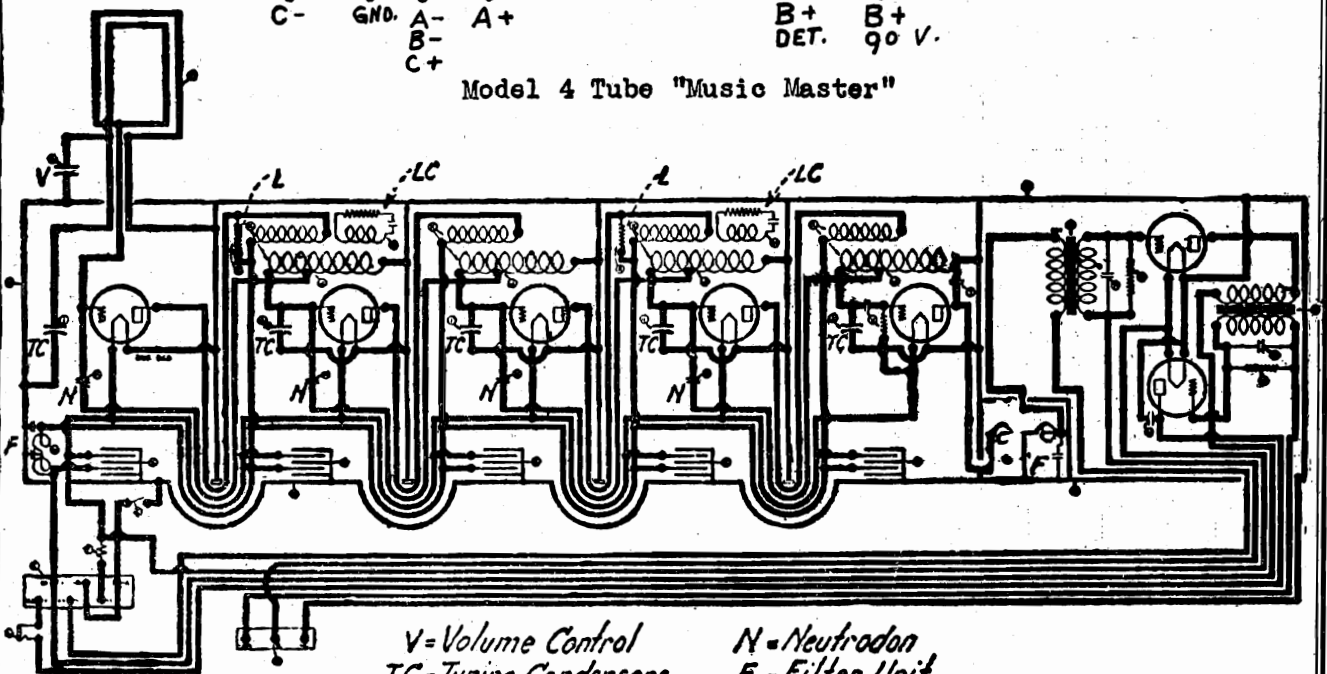

V=Volume Control N=Neutradon
 TC=Tuning Condensers F=Filter Unit
 LC=Losser Coil L=Leak

Model 7 Tube Music Master

MODEL B-1, B-2 Bantam

WARE MANUFACTURING CORP.

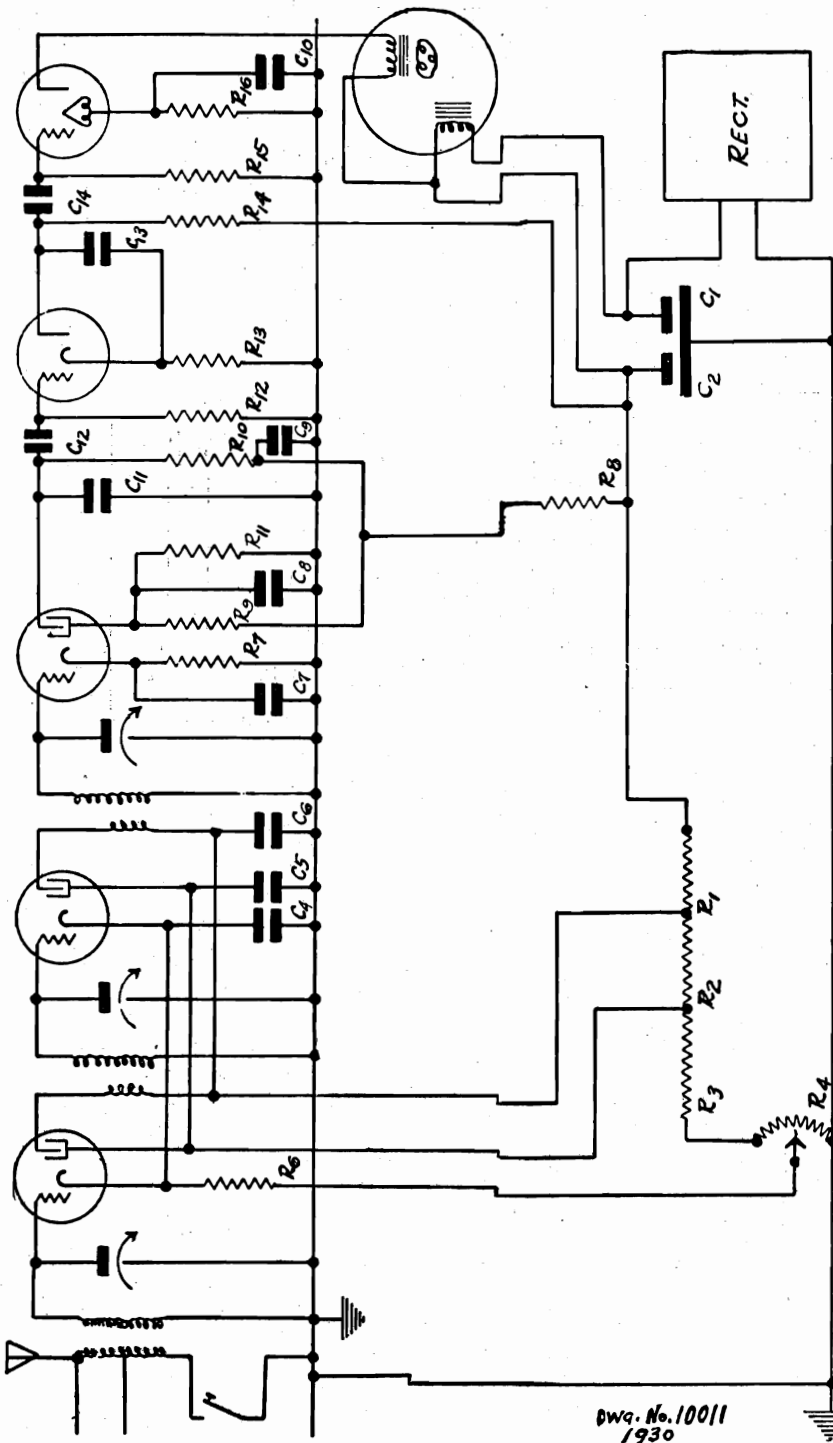

Dwg. No. 10011
1930

- | | |
|--------------------------------|--------------------------------|
| C 1--14 Mfd. Electrolytic | - First Filter Condenser |
| C 2--2 " | - 2nd Filter Condenser |
| C 3-- | - |
| C 4--0.1 " | - R. F. Cathodes Bypass |
| C 5--0.1 " | - R. F. Screens Bypass |
| C 6--0.1 " | - R. F. Plates Bypass |
| C 7--1.0 " | - Det. Cathode Bypass |
| C 8--0.1 " | - Det. Screen Bypass |
| C 9--0.25 " | - Det. Plate Bypass |
| C 10--1.0 " | - Power Tube Bias Bypass |
| C 11--0.005 Mfd. 350 V. | - Midset - Det. Plate to Gnd. |
| C 12--0.006 " | - Det-1st Audio Coupling |
| C 13--0.02 " | - 1st Audio Plate to K. Bypass |
| C 14--0.006 " | - 1st Audio-Pr. Tube Coupling |
| Variable Condenser, 3 Sections | 467 M. Mfd. Each. |
-
- | | | |
|----------------|--------------------------|-----------------------------------|
| R 1--7600 ohms | 1 watt carbon | - R. F. Voltage Divider |
| R 2--10000 " | " | " |
| R 3--7600 " | " | - R. F. " |
| R 4--1000 " | Wire Wound Potentiometer | - Volume Control |
| R 5 | | |
| R 6--280 " | 1 watt carbon | - R. F. Bias |
| R 7--25000 " | " | - Det. Bias |
| R 8--25000 " | " | - Det. B. Common to Pl. and S. G. |
| R 9--1/2 Meg. | " | - Det. Screen Supply |
| R 10--1/4 " | " | - Det. Plate Supply |
| R 11--75000 " | " | - Det. Screen Shunt |
| R 12--1/2 Meg. | " | - Det. Screen Supply |
| R 13--1000 " | " | - 1st Audio Grid to Ground |
| R 14--25000 " | " | - 1st Audio Plate Supply |
| R 15--1/2 Meg. | " | - P. F. Grid to Ground |
| R 16--1500 " | " | - P. F. Bias |

"BANTAM" CHASSIS TYPE B-1 AND B-2

WELLS - GARDNER & CO.

MODEL .052 Series
Schematic
Voltage

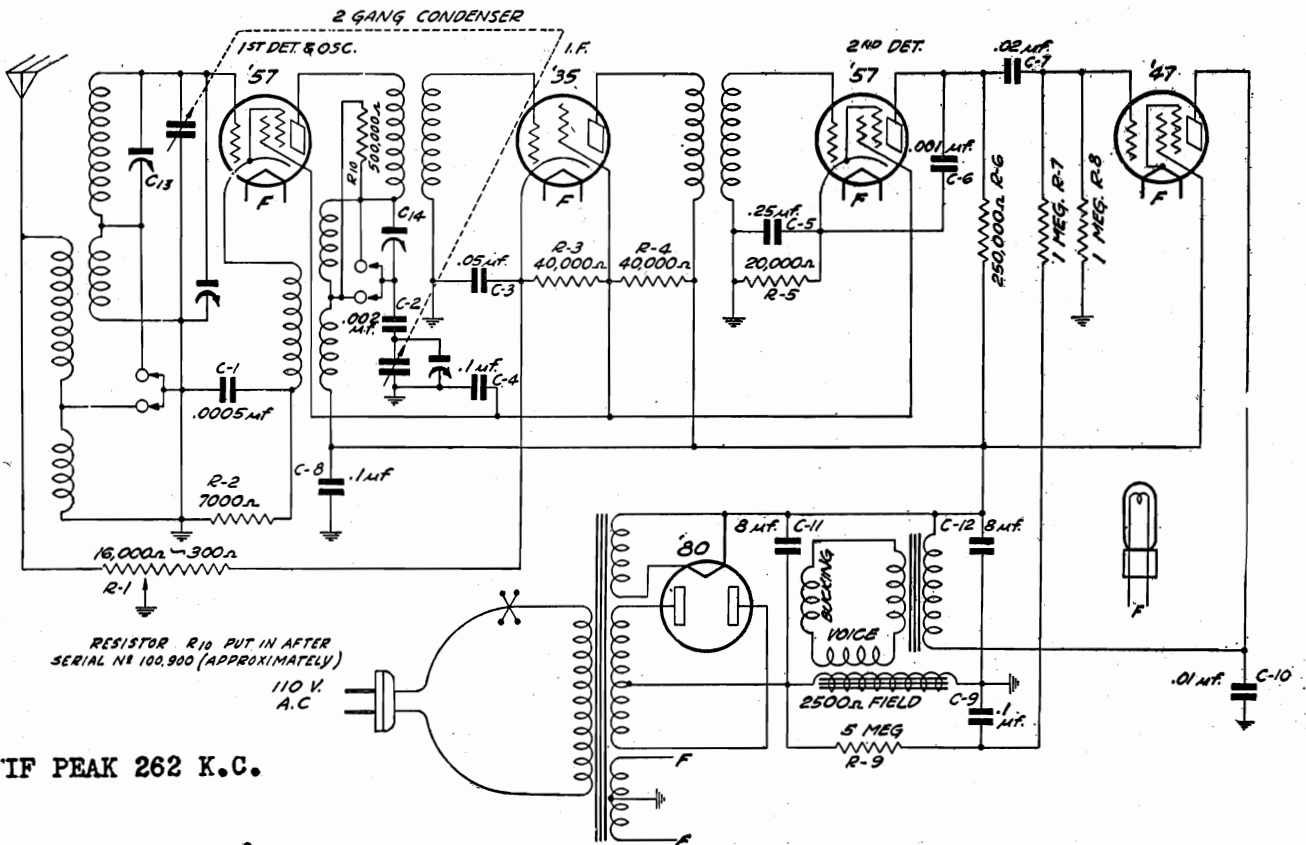

IF PEAK 262 K.C.

Tube	Fil.	Plate to Cathode	Screen to Cathode	Grid to Cathode	Plate to Plate Crnt.	
1st Det	2.15	225	90	4.	.5	
IF Amp	2.15	230	90	3.2*	6.2	
2nd Det	2.15	170	90	4.3	.2	
Audio	2.15	225	240	14.**	23.	
Rect.	4.75	620 volts AC from plate to plate				

* When read with cord and plug, ground the control grid.
** High resistance interferes with correct reading.

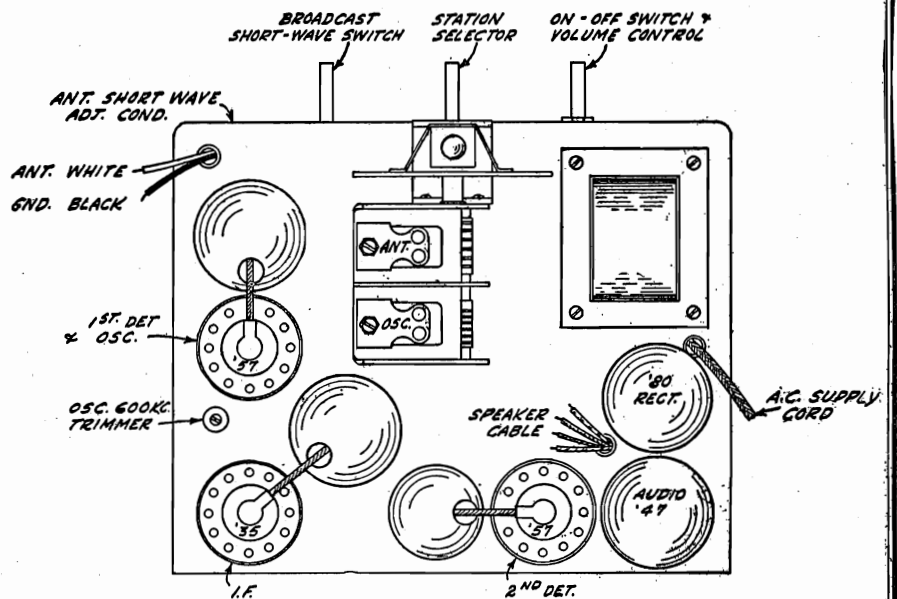

—)

—)

)

)

)

MODEL Jewell
198,199
2nd Type
MODEL Jewell 209

WESTON ELECTRICAL INSTRUM'T CORP.

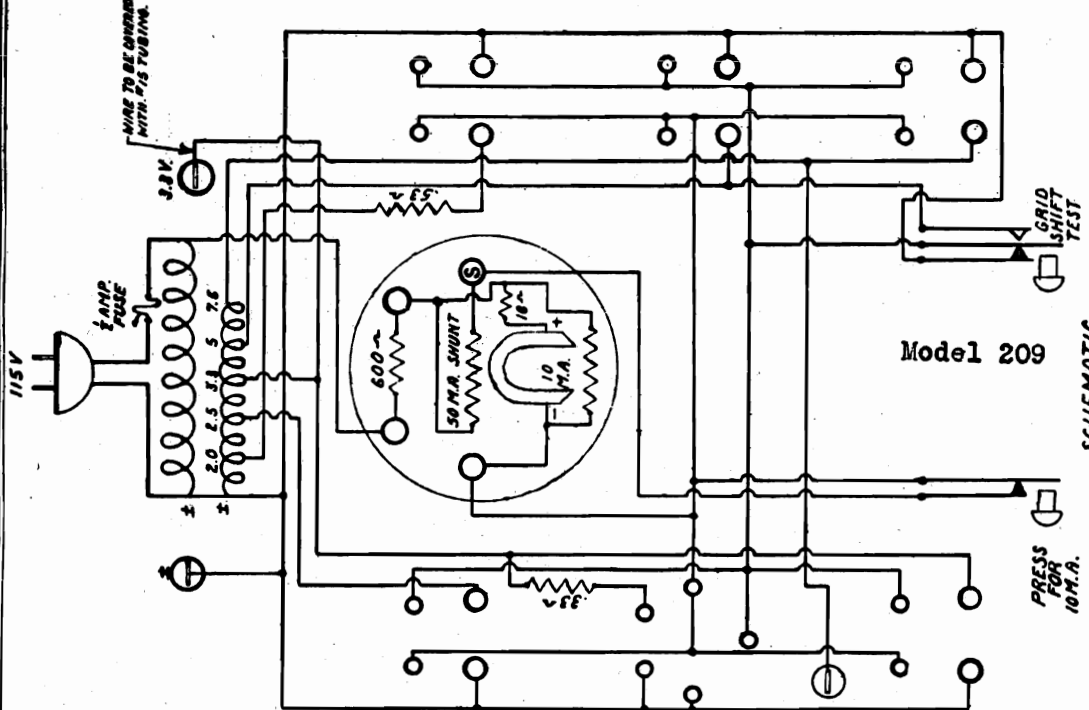

SCHEMATIC
LOOKING AT BACK OF CASE

THIS DIAGRAM APPLIES TO ALL PAT. 209 WITH SERIAL No 6371 AND OVER FOR PAT. 209 WITH SERIAL No 4972 TO SERIAL No. 6371 SEE M.D. 209 ISSUE 7.
FOR PAT. 209 WITH SERIAL No. UNDER 4972 SEE M.D. 209 ISSUE 5.

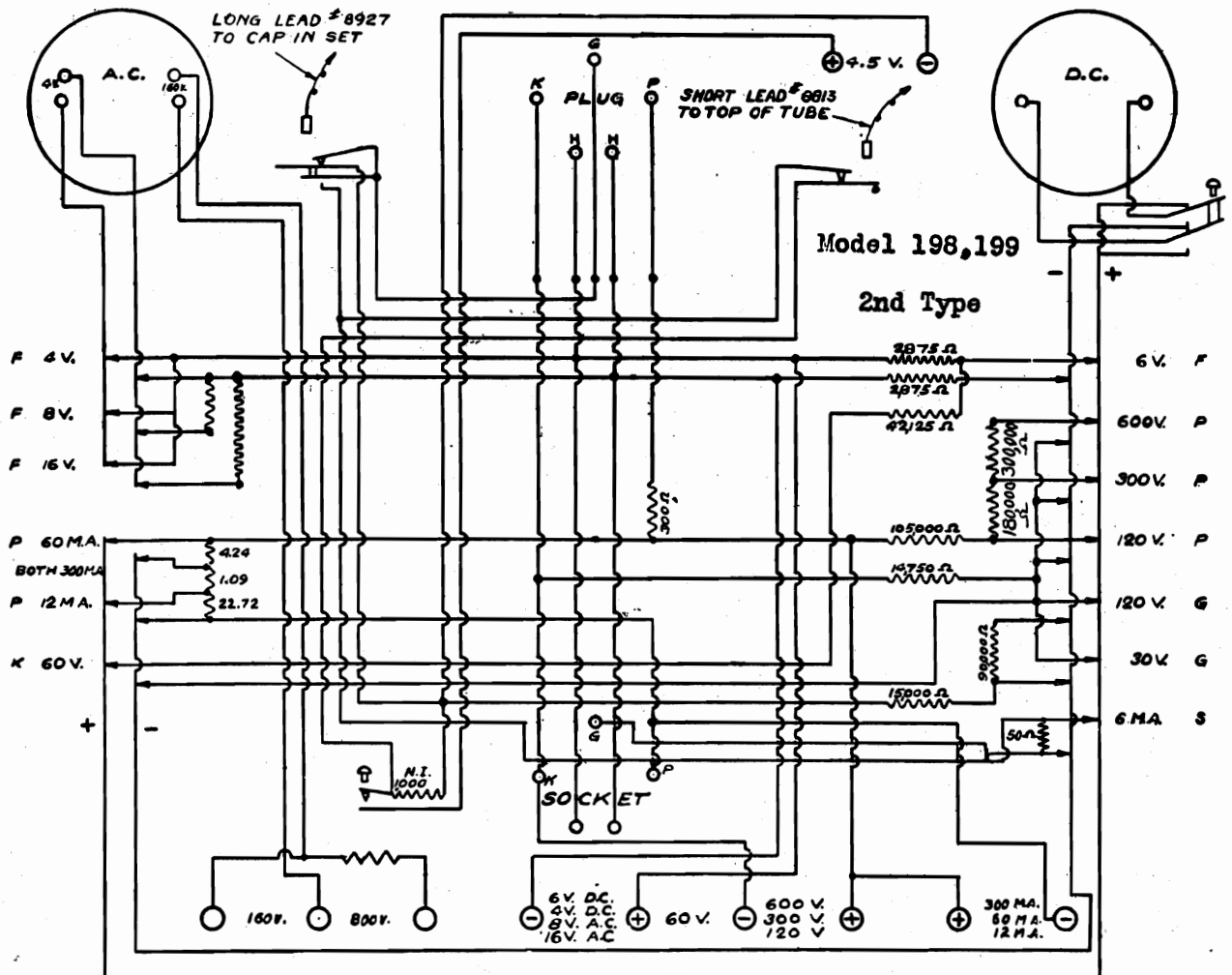

MODEL Jewell 214

WESTON ELECTRICAL INSTRUM'T CORP.

WIRING DIAGRAM
JEWELL PAT. 214 TUBE CHECKER

OWG. NO-214
FORM 3176
ISSUE 8
N-531

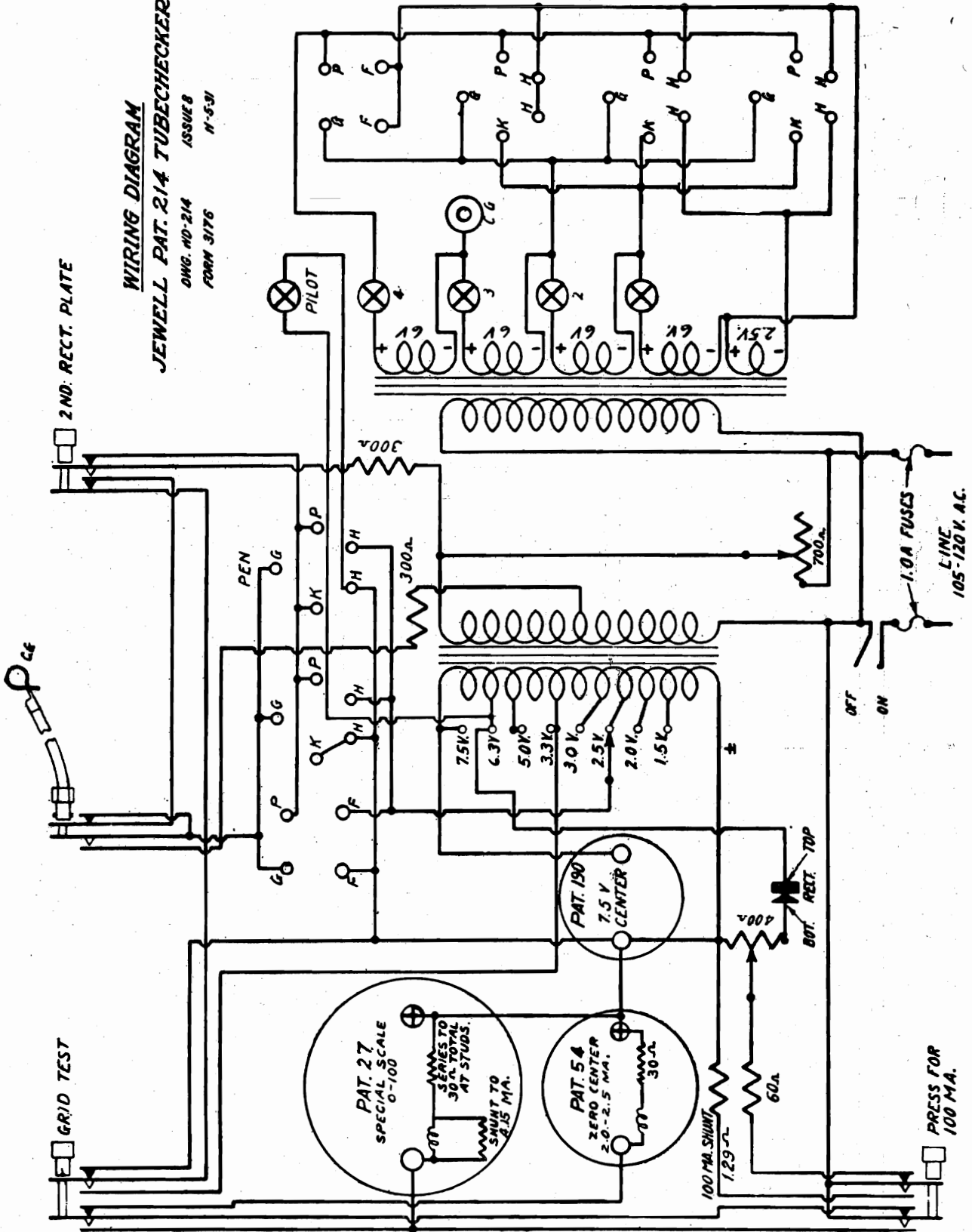

WESTON ELECTRICAL INSTRUM'T CORP.

MODEL Jewell
533
MODEL Jewell
534

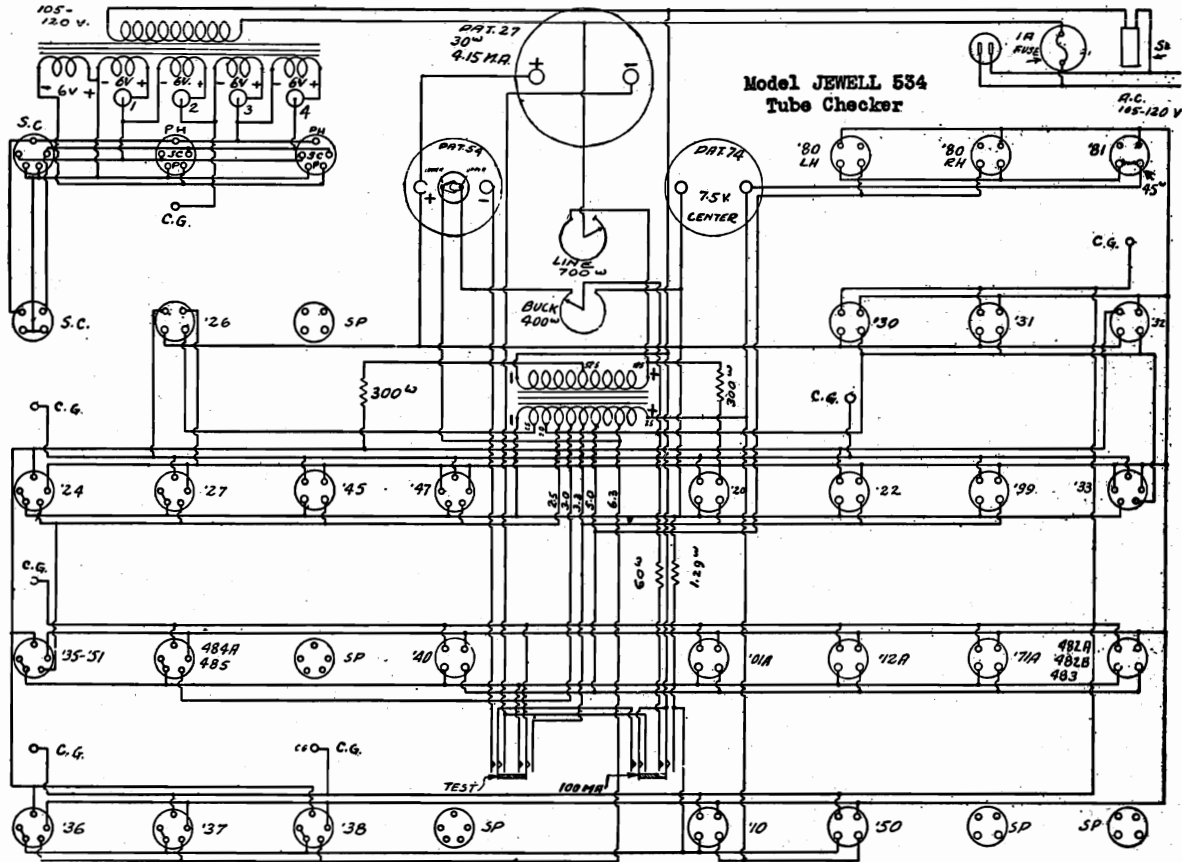

Model JEWELL 534
Tube Checker

Model JEWELL 535
Tube Checker

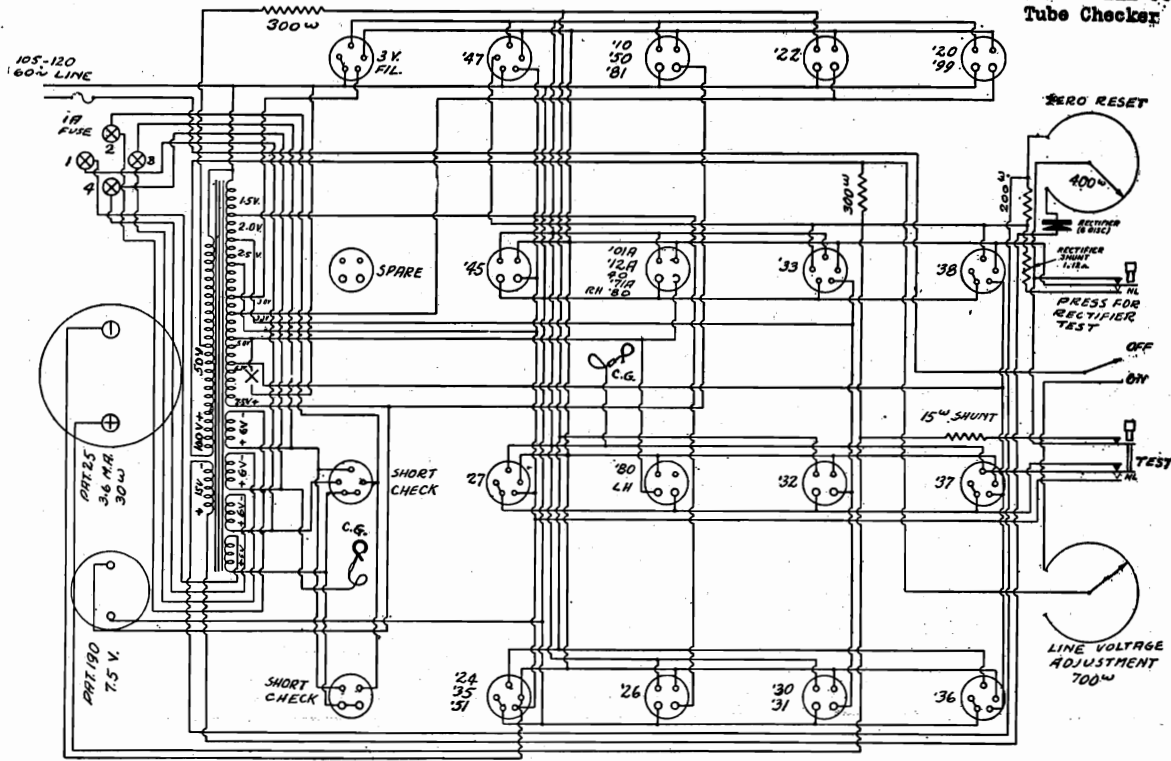

VIEWING TOP OF PANEL

WESTON ELECTRICAL INSTRUM'T CORP.

MODEL Weston 676

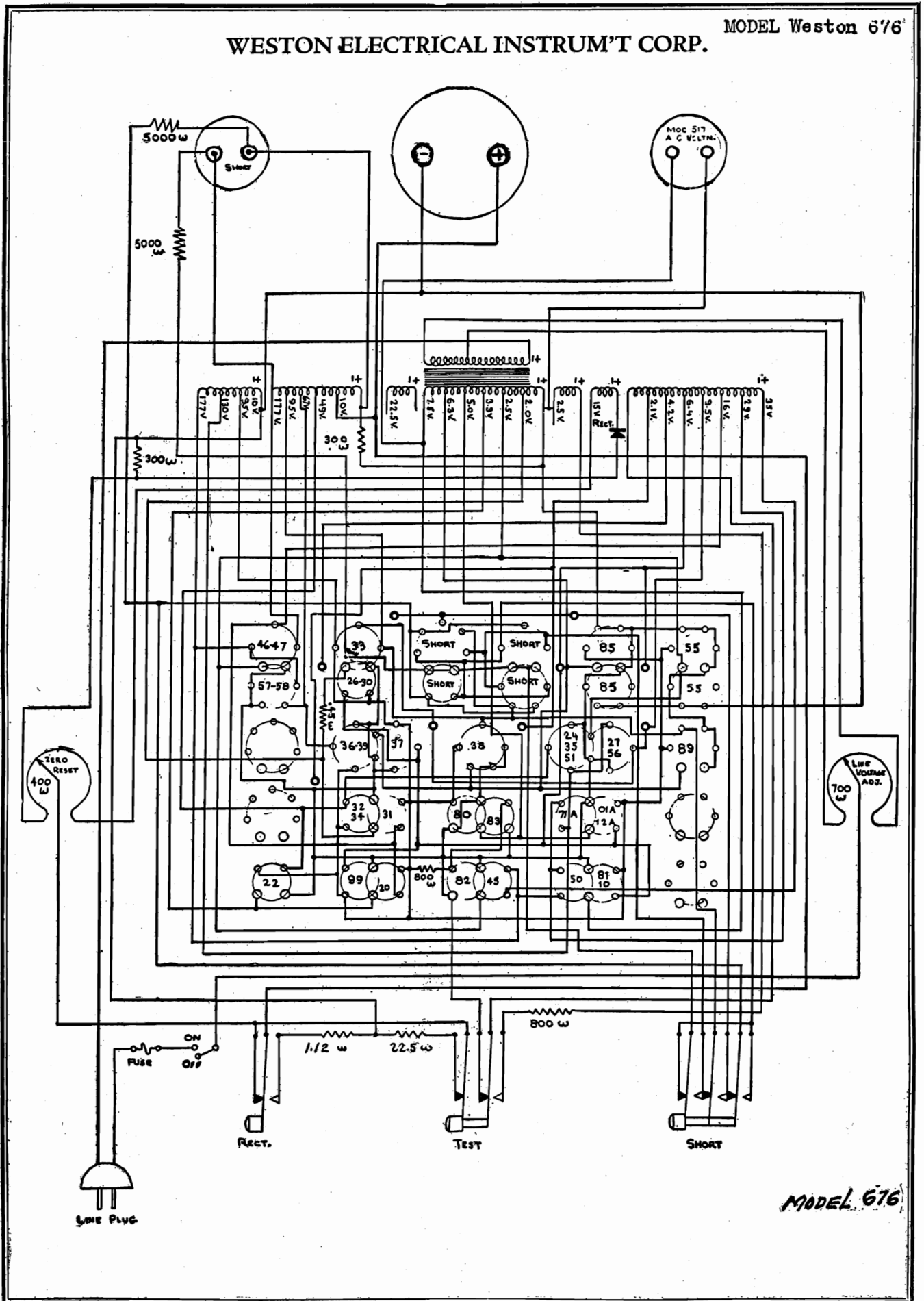

MODEL 676

WILLARD STORAGE BATTERY CO.

MODEL B Unit 3095
 MODEL B Unit 3310,
 4310
 MODEL B Unit 4095

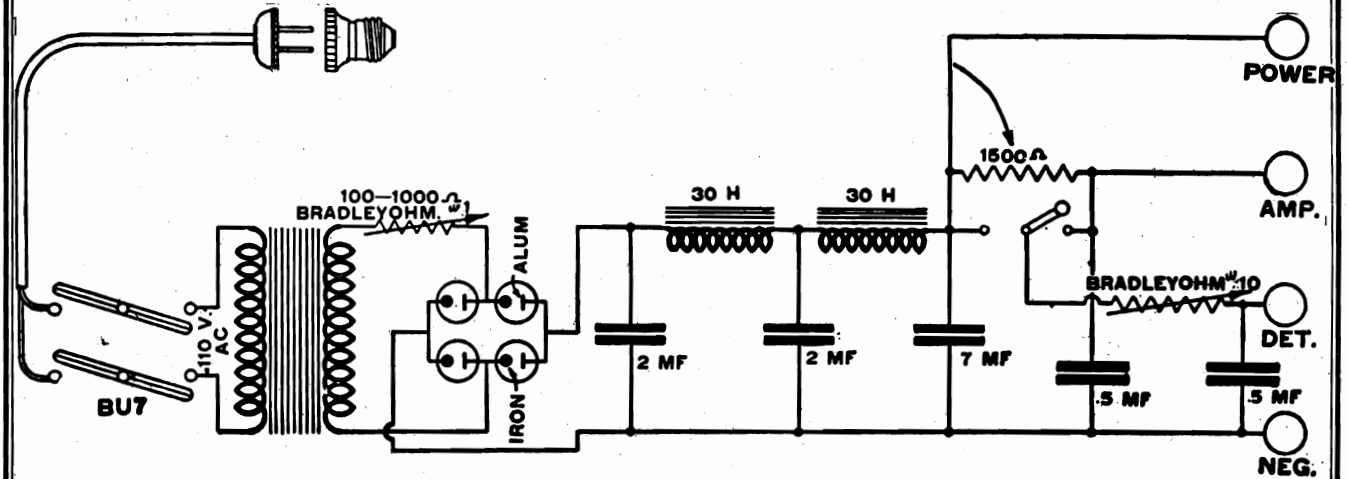

Standard "B" Power Unit, Part No. 3095, 50-60 Cycle

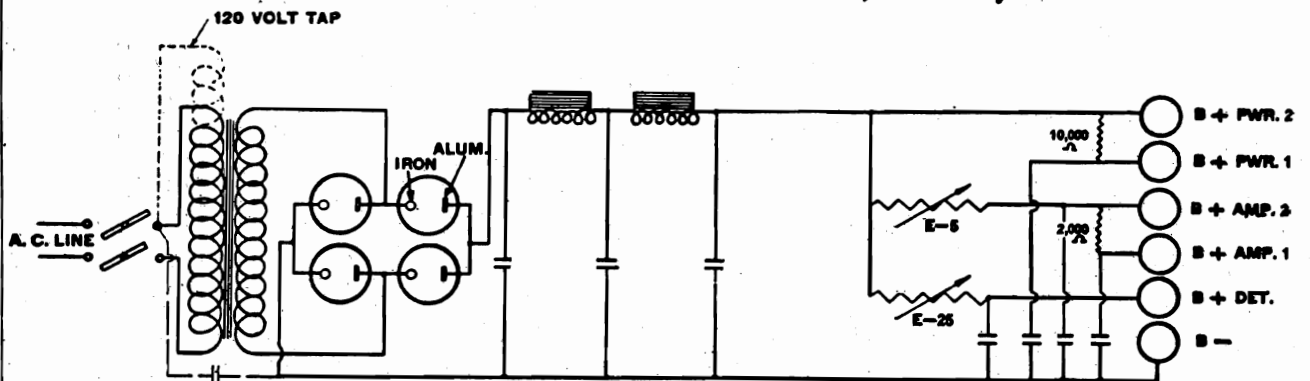

Super "B" Power Units, Part Nos. 3310 and 4310
 25-40 and 50-60 Cycle

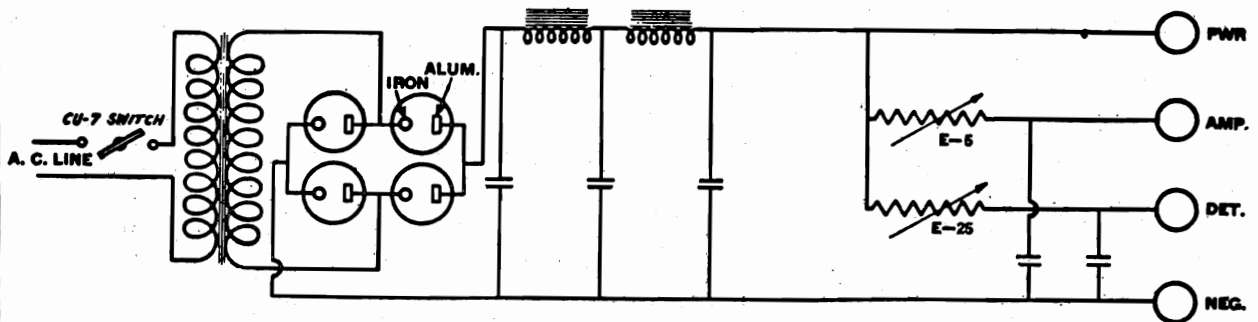

Standard "B" Power Unit, Part No. 4095, 50-60 Cycle

MODEL AB 6301
MODEL AB 3301
G.E. Charger
MODEL AB 3301
Westinghouse

WILLARD STORAGE BATTERY CO.

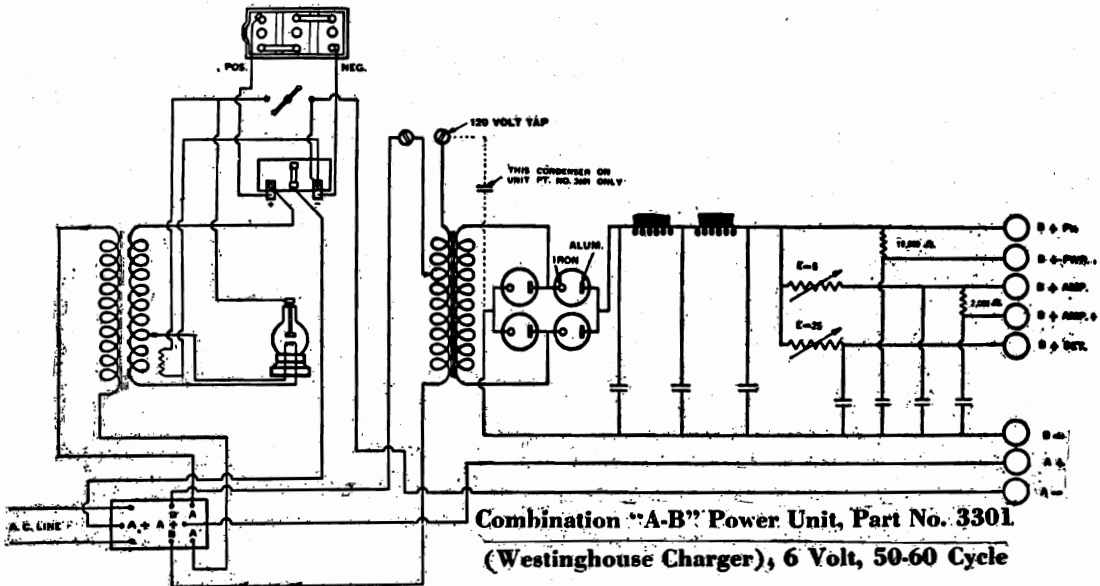
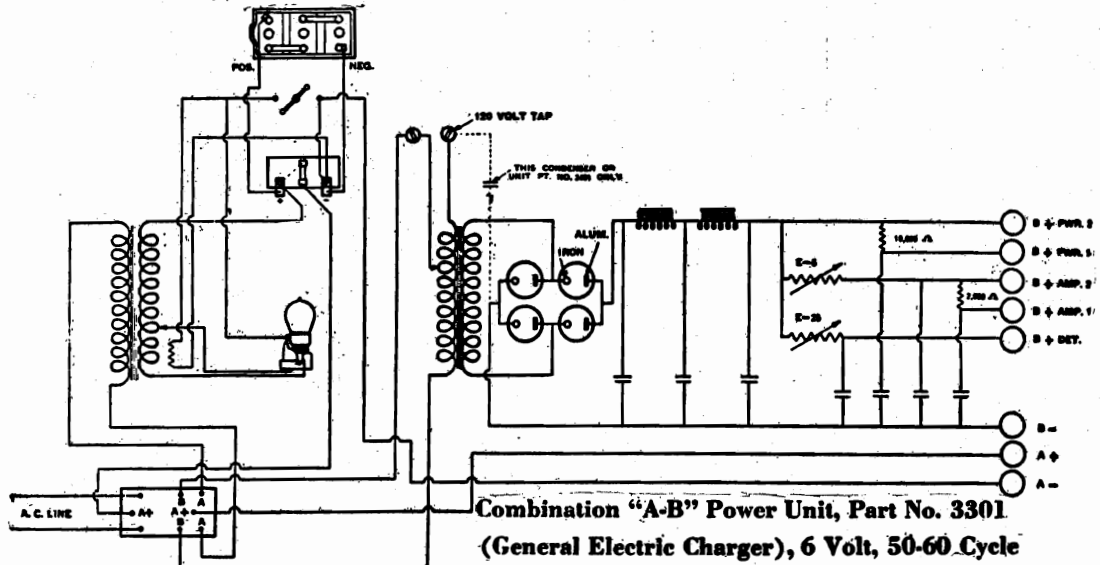
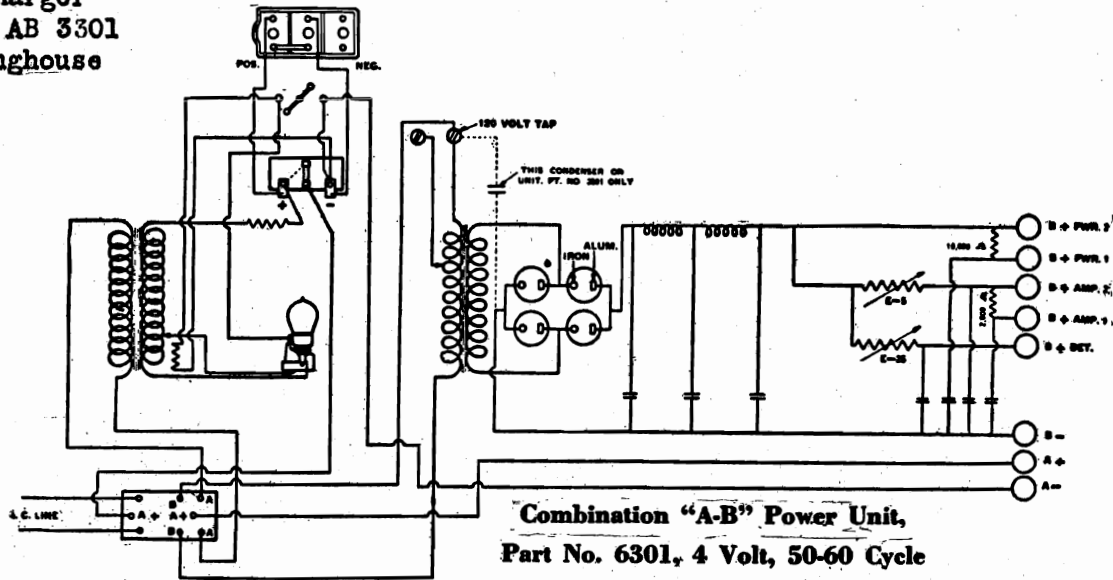

MODEL ZE-9
for Models 11-E, 14-E

ZENITH RADIO CORP.

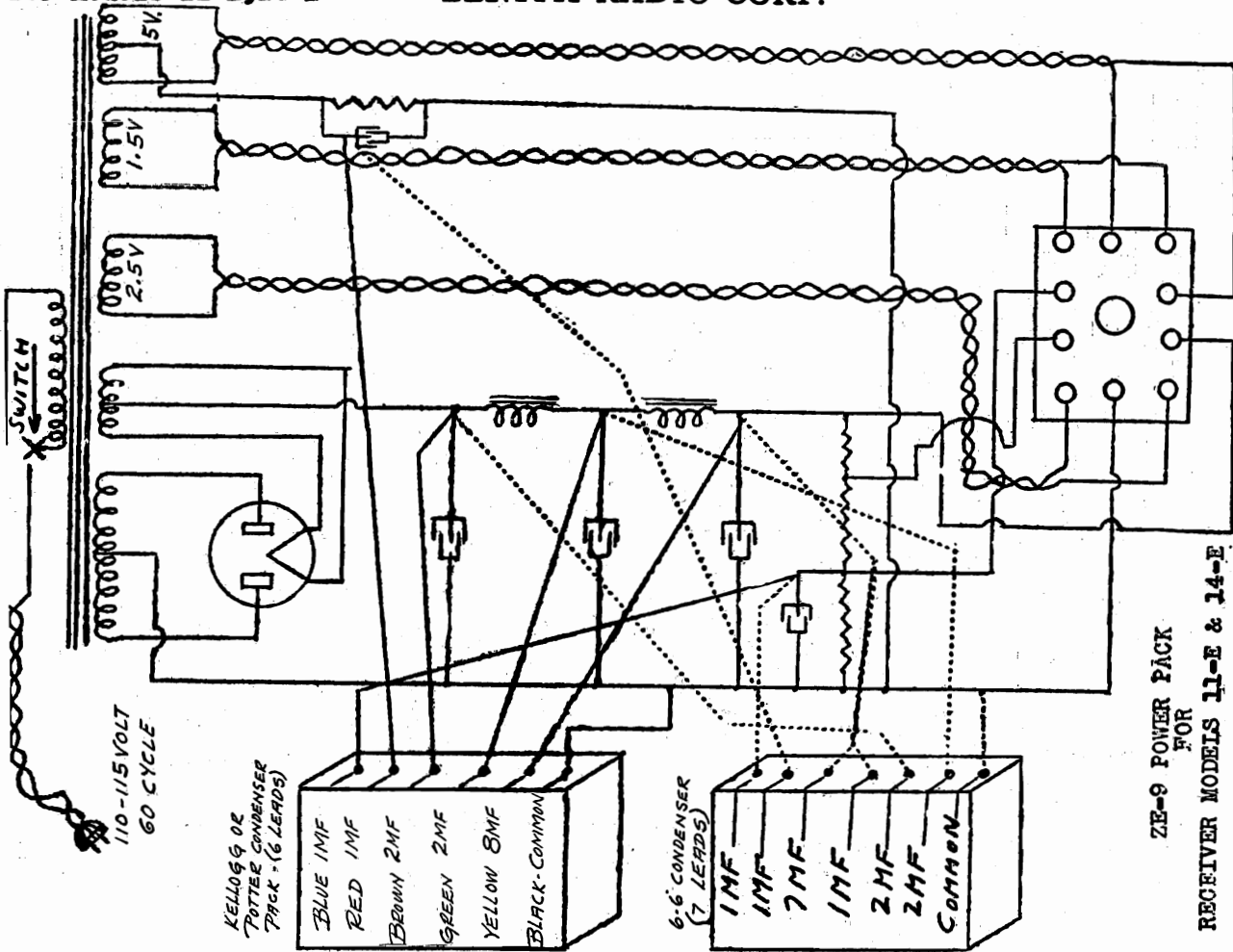

ZE-9 POWER PACK
FOR
RECEIVER MODELS 11-E & 14-E

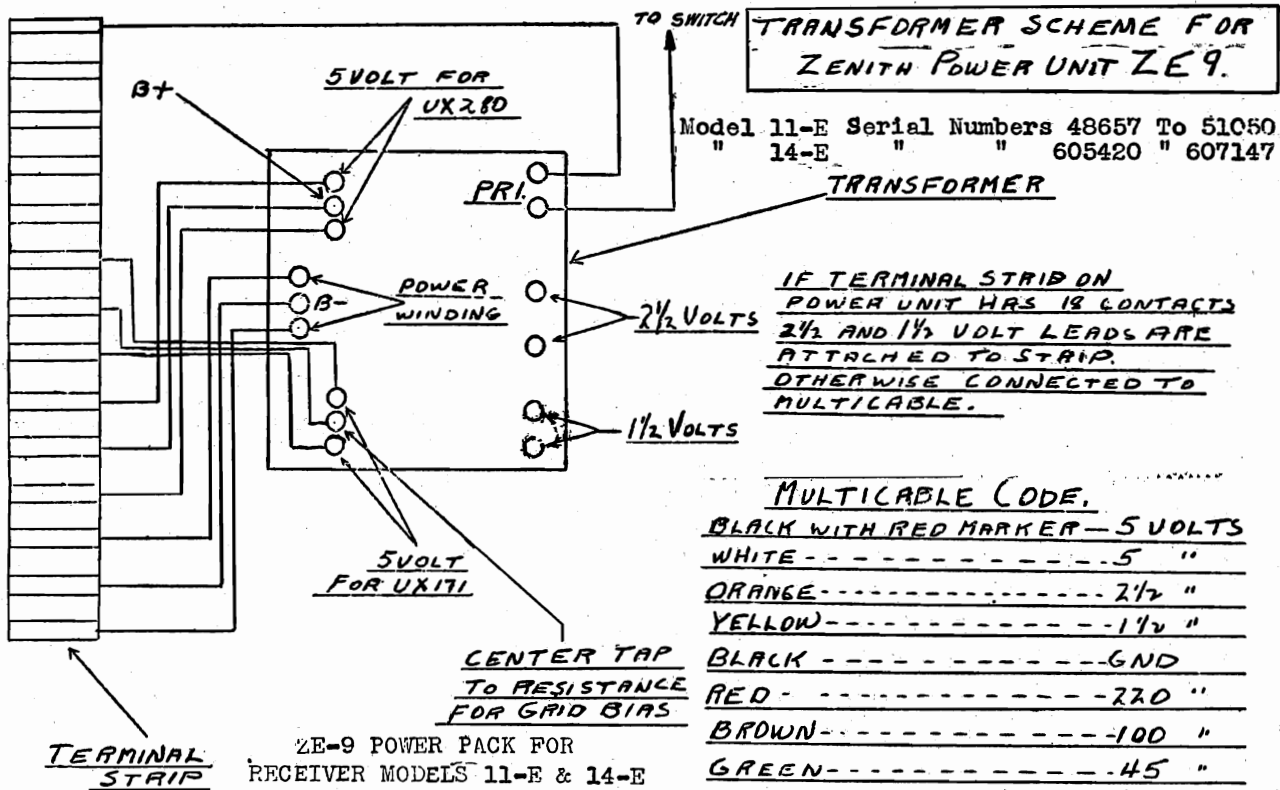

MODEL 91,92
Schematic #2

ZENITH RADIO CORP.

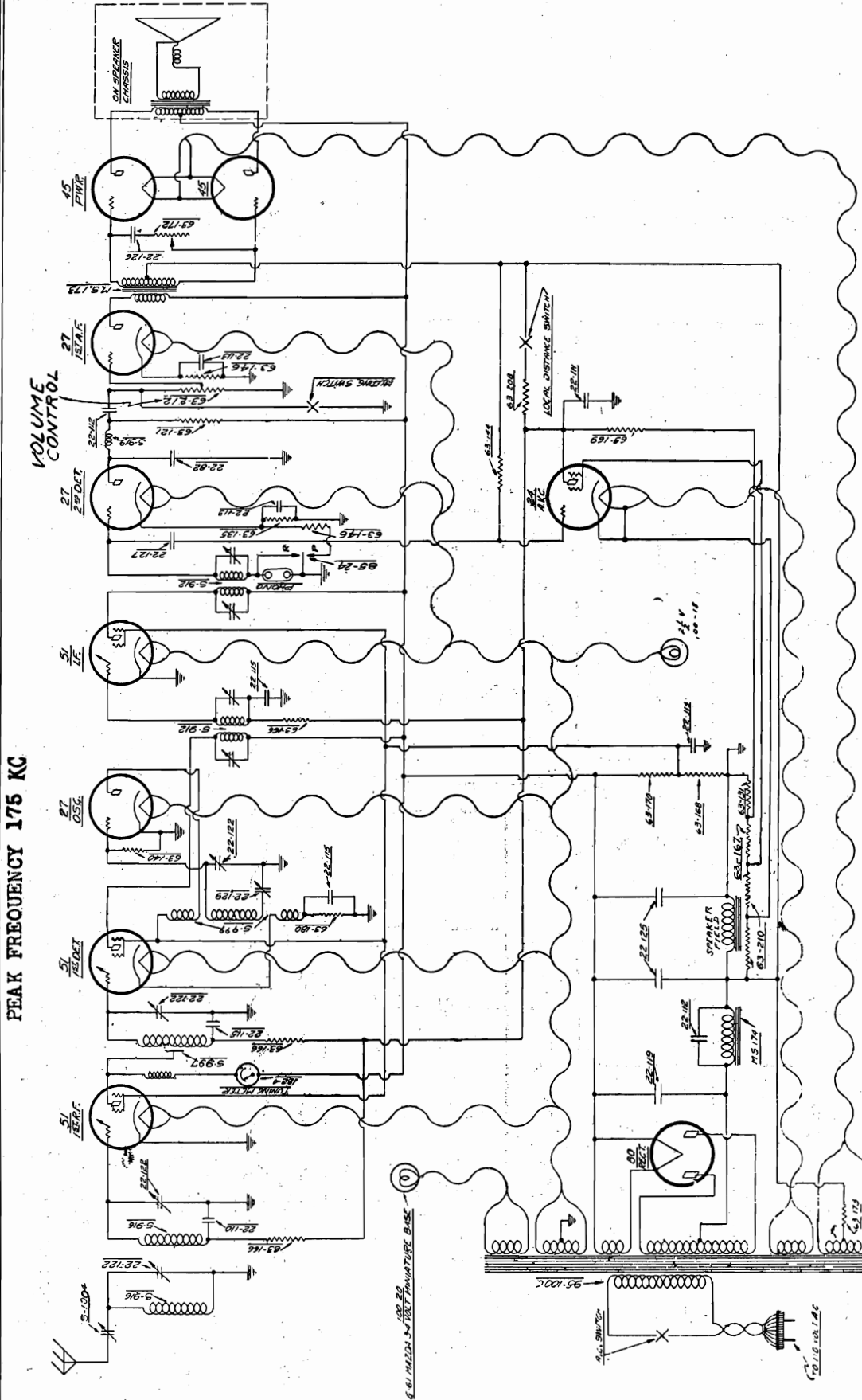

REVISED CIRCUIT - SCHEMATIC DIAGRAM # 2

ZENITH RADIO CORP.
CHICAGO, ILL.
MODEL 904 TO TUBE SUPERHETERODYNE AMH 6183

MODEL 91 (2014) FOR SERIAL NUMBERS AFTER 373,334
MODEL 92 (2014) FOR SERIAL NUMBERS AFTER 301,394

MODEL 91,92
Circuit Data

ZENITH RADIO CORP.

- * MODEL 91 (2014) SERIAL NUMBERS AFTER 373,334
* MODEL 92 (2014) SERIAL NUMBERS AFTER 301,394 (4B)

In all receivers, bearing serial numbers 373,334 on model 91 and 301,394 on model 92, or higher, the manual control has been removed from the A.V.C. cathode and placed in the grid circuit of the first A.F. stage. A tapped resistor takes the place of the original control. By use of this new system, the automatic volume control operates independently and at full efficiency, manual volume being controlled by varying the audio output.

Since the A.V.C. or R.F. circuit remains constant, the tuning meter will show maximum swing on the station at any manual control setting. Originally the meter action decreased as the volume was lowered.

The parts list shown previously, except for the substitutions given below, should be used when ordering replacement components.

PARTS CHANGE.

- 1 Audio volume control, part # 63-212 List \$ 1.65
1 Center tapped resistor, part # 63-210 List \$ 0.50
Deduct the 63-171 volume control.

-
- * MODEL 91 (2014) SERIAL NUMBERS AFTER 375,532
* MODEL 92 (2014) SERIAL NUMBERS AFTER 302,007 (4C)

All ten-tube Zenith Superheterodynes after the above serial numbers will incorporate a variable Sensitivity Control in place of the original Local-Distance switch. The diagram (*) indicates its position as being connected into the I.F. cathode. In addition to the control unit the first detector coil has been replaced by one having slightly different construction to provide equal sensitivity over the entire tuning range. It is not advisable to make this change in receivers subsequent to the above numbers, for the reason that each complete set of chassis coils must be inductively matched, otherwise the efficiency of the receiver will be seriously affected.

The following alteration makes the parts list directly applicable to the improved models:

DEDUCT

- 1 Local-Distance switch, part # 85-31
1 First detector coil, " # S-997
1 Eight megohm resistor " # 63-224
1 250,00 ohm resistor " # 63,135

ADD

- 1 Sensitivity Control, part # 63-228
1 Det. coil assembly " # S-2104
1 Bypass condenser, " # 22-115
1 50,000 ohm resistor, " # 63-136

ZENITH RADIO CORP.

MODEL 91, 92
Balancing Notes

Balancing Chassis

Every Zenith Superheterodyne Receiver is carefully balanced on laboratory equipment before leaving the factory and should not require further attention in this respect. However, in the event that some part of the R. F. circuit has been changed, or the adjustments shifted by mishandling, the chassis may be rebalanced as follows:

If an oscillator is available more accurate results will be obtained. It should be accurately calibrated from 1500 to 550 kilocycles and should also have provision for generating a 175 kilocycle signal. In cases where an oscillator is not available a fairly good result may be had by listening to stations which operate as nearly as possible to the extreme ends of the dial. Although an output meter will give most accurate results, satisfactory adjustments can be made simply by listening to the speaker.

The chassis should be removed from the cabinet so that all adjustments are easily accessible. Next place the test oscillator in operation and connect it direct to the antenna and ground posts of the receiver. It should then be set to 1500 kilocycles and the receiver tuned to the same reading on the dial. If the oscillator is not accurate the stations will not be received on their proper calibration. If a station is used for this purpose, the dial pointer should first be set to the exact frequency of the station being received. Beginning with the variable condenser tuning section at the extreme left, which tunes the oscillator circuit, the trimmer should be regulated for maximum response, in either the loud speaker or output meter. It will be noticed that the second section does not employ a vernier adjustment. This stage is resonated by adjusting the antenna compensator knob as explained in the instruction card. The third, or 1st R. F. trimmer, is adjusted in the same manner as the oscillator. If at any time the volume reaches a very high level, so that it is not possible to determine slight changes, it should be reduced by means of the volume control knob so as to be barely audible. The fourth, or 1st detector section, is next in order and its trimmer should also be adjusted for resonance.

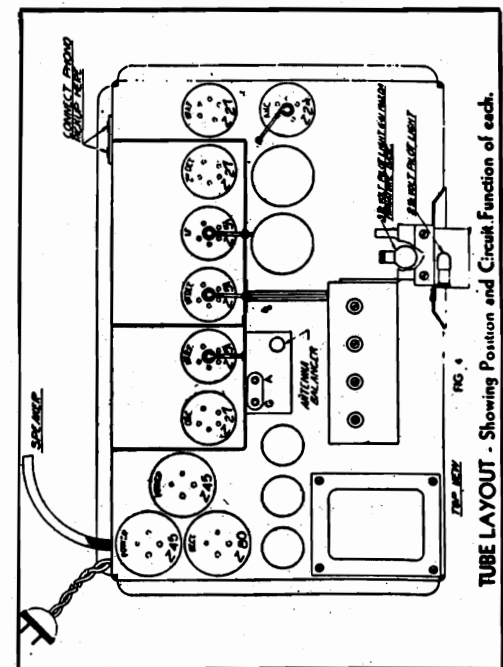
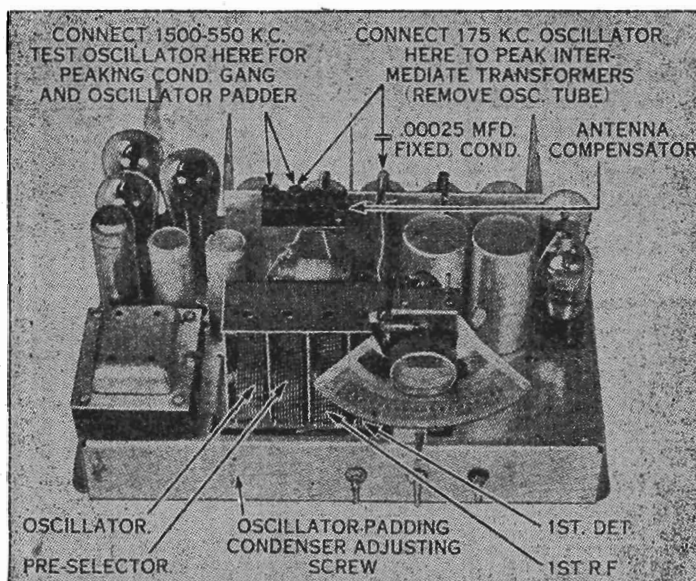

After the vernier adjustments have been completed the test oscillator should be set at 550 kilocycles and the dial of the receiver turned until the oscillator signal is tuned in. Now the oscillator padding condenser (see fig. 3) should be very carefully adjusted with a screw driver for maximum output of the receiver, while rocking the tuning condenser back and forth over the signal. This padding adjustment brings the oscillating circuit of the receiver in resonance with the remaining tuned circuits and, thereby, enables it to tract accurately over the entire scale. The receiver will now operate at full efficiency and all stations will be received at their proper calibration. If this is not found to be entirely so, the entire balancing operation should be repeated.

The intermediate transformers used in the ten tube Superheterodyne have been accurately peaked at 175 kilocycles on a temperature controlled crystal oscillator before leaving the factory. It is not recommended that their adjustments be tampered with unless an oscillator is available which is very accurately calibrated at 175 kilocycles, or unless the serviceman is absolutely certain the trouble lies in their adjustment. However, if it is necessary to check the adjustments, the 175 K. C. test oscillator may be connected to the grid terminal of the 1st detector through a .00025 fixed condenser. The ground lead of the test oscillator is connected to the ground post of the receiver. The oscillator tube must be removed from the chassis while this operation is being performed. Four adjusting screws are provided under the chassis directly beneath the intermediate transformers, which tune the plate circuit of the 1st detector, grid and plate circuits of the I. F. stage, and grid circuit of the second detector. (See wiring diagram.) Beginning with the 2nd detector grid vernier, each adjusting screw should, in turn, be set for maximum signal output from the speaker or output meter. For best results the verniers should be gone over twice in the same rotation always keeping the output from the test oscillator at the weakest possible strength in order to determine slight variations in volume.

**MODEL 91,92
Parts List**

ZENITH RADIO CORP.

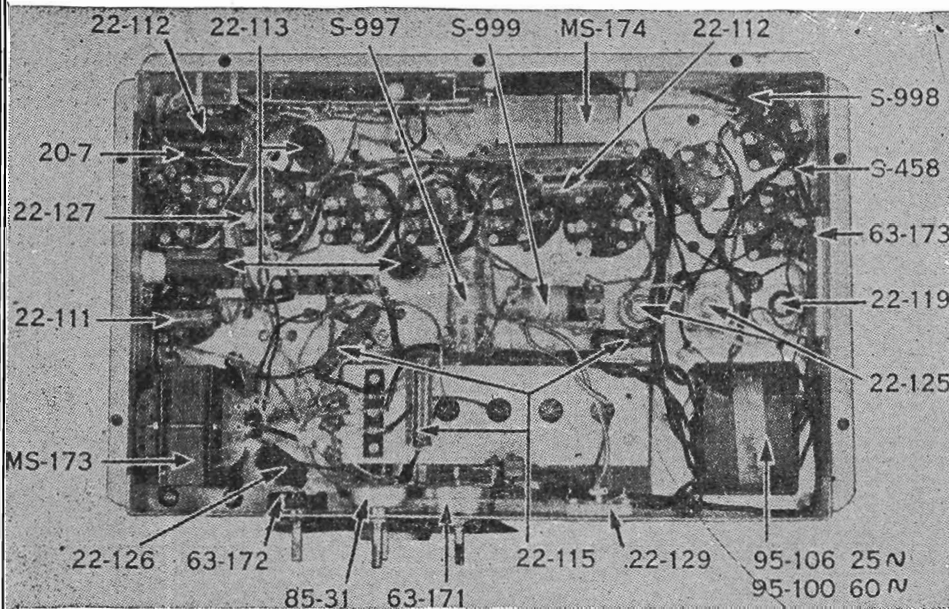

Socket Voltages

Type	Position	Flt. Value	Plate Vols.	Grid Vols.	Control Vols.	Plate Int. A.	S.C. Vols.
Z-11	1st. R. F.	2.21	175	2	0	2	100
Z-11	1st. Det.	2.21	175	3.1	4	3.1	90
Z-17	Osc.	2.2	70	0	0	8.1	0
Z-11'	I. F.	2.2	200	4	0	2.1	115
Z-17	2nd. Det.	2.2	115	0	9	1	0
Z-17	1st. Aud.	2.2	145	0	11	6.1	0
Z-41	P. P.	2.2	275	14	0	10	0
Z-41	P. P.	2.2	275	14	0	10	0
Z-24	A. V. C.	2.2	15	4	0	0	14
Z-80	Rect.	4.8	155	0	0	7.6	0

Voltage readings are with a vacuum tube test meter. Manual volume control in maximum position and antenna and ground disconnected. See Page 111

CONDENSERS

22-82	.001	Mfd.	(2nd Det. Plate)	\$.30
22-110	.1	Mfd.	(R. F.)	.50
22-111	.03	Mfd.	(A.V.C. Plate)	.30
22-112	.1	Mfd.	(2 Used. See Footnote)	.35
22-113	.5	Mfd.	(3 Used. See Footnote)	.50
22-115	.1	Mfd.	(3 Used. See Footnote)	.30
22-119	6.	Mfd.	(High Voltage Electrolytic)	1.50
22-122	Four Gang	Variable		7.00
22-125	8.	Mfd.	(Low Voltage Electrolytic. 2 Used)	1.50
22-126	.006	Mfd.	(Tone Control)	.55
22-127	.000025	Mfd.	(A.V.C. Coupling)	.35
22-129		Oscillator, Padding		.75

RESISTORS

63-111	2M	Ohm	1 Watt	(1st A. F. Cathode)	\$.30
63-121	100M	Ohm	1 Watt	(2nd Det. Plate)	.30
63-131	400	Ohm	1/2 Watt	(A.V.C. Voltage Divider)	.30
63-135	25M	Ohm	1/2 Watt	(2nd Detector Cathode)	.30
63-137	250M	Ohm	1/2 Watt	(1st A. F. Grid)	.30
63-140	1 Meg.	Ohm	1/2 Watt	(Oscillator Grid)	.30
63-144	3 Meg.	Ohm	1/2 Watt	(A.V.C. Grid)	.30
63-146	2M	Ohm	1/2 Watt	(1st A. F. Cathode)	.30
63-166	1400	Ohm	1/4 Watt	(3 Used. See Footnote)	.30
63-167	8M	Ohm	1 Watt	(A.V.C. Divider)	.30
63-168	3600	Ohm	2 Watt	(Plate Voltage Divider)	.50
63-169	400M	Ohm	1/2 Watt	(A.V.C. Plate)	.30
63-170	2800	Ohm	2 Watt	(Plate Voltage Divider)	.50
63-171				Manual Volume Control and Switch Assembly	1.65
63-172				Tone Control	1.00
63-173	750	Ohm		Metal Mounting (Power Tube Bias)	.40
63-180	1M	Ohm	1/2 Watt	(1st Detector Cathode)	.30
63-188	4 1/2 Meg.	Ohm	1/2 Watt	(A.V.C. Plate)	.30

Note: All resistors employed in this receiver are marked in accordance with R. M. A. standards. Color code charts may be obtained by writing direct to the Erie Resistor Corp., Erie, Pa.

S-912	Intermediate Transformer Complete (2 Used) (Specify with or without grid lead)	\$2.50
S-916	Antenna and 1st R. F. Coils	.75
S-997	1st Detector Complete	1.25
S-999	Oscillator Coil Complete	1.25

Note: 22-112 Filter Choke By-pass and 1st Audio Coupling Condensers
 22-113 1st R. F., 1st Det. and I. F. Screen. 2nd Det. and A. F. Cathode.
 22-115 2nd Det. and I. F. Grid Return. 1st Det. Cathode.
 63-166 1st R. F., 1st Det. and I. F. Grid Return Resistor.

MODEL 10,11,12,102,112,122
Power Unit

ZENITH RADIO CORP.

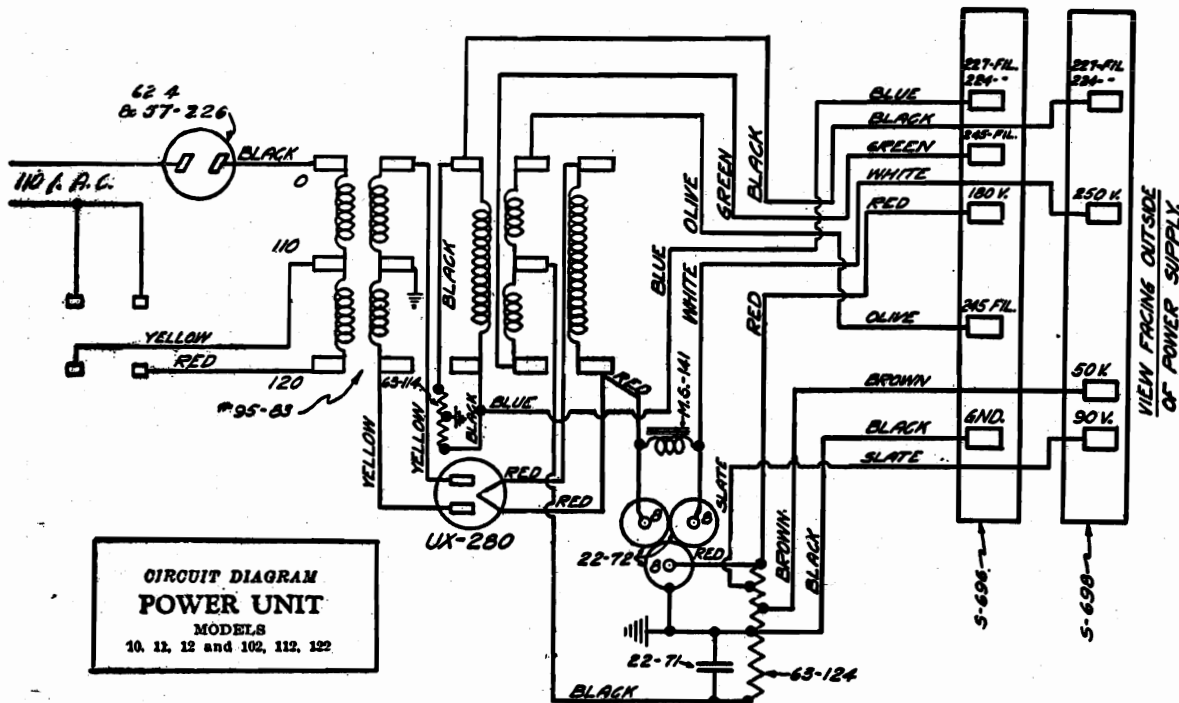

CIRCUIT DIAGRAM
POWER UNIT
MODELS
10, 11, 12 and 102, 112, 122

A new development in the form of capacity coupling is used between the R. F. stages. Close examination will reveal the fact that it comprises a single band of bus-bar wire. This band is connected from the plate terminal of the preceding R. F. stage and coupled to the grid coil of the following R. F. stage. The position of this band is permanently adjusted at the factory and should never be altered or tampered with unless the available line voltage is extremely low.

The distance from the coupling band to the grid or top end of the R. F. coil entirely governs the stage coupling and efficiency of the set. If this band is too close to the grid end, excessive coupling will result, causing a decided lack of selectivity. If the band is placed too low, the result will be a lack of sensitivity. Midway between the coil winding is the exact and most efficient operating position. If it is found necessary to reset this band, insulating cement or other fastening substance should be applied to hold it in position, since loose vibration would cause frequency flutter.

The R. F. plate chokes are concealed beneath the R. F. coil base, between the base and sub-panel. These chokes have an inductance of 6.75 M. H. and can be distinguished from the detector plate choke by the fact that they have 150 less turns. If an occasion arises which necessitates removing an R. F. choke, the serviceman should make certain that the 1/8" spacing is maintained between the choke and the R. F. coil base. To neglect this important adjustment may cause erratic operation of the receiver.

Occasionally, and especially if the receiver has remained idle for a long length of time, it may have a tendency to oscillate. This is always due to poor contact between the wipers and rotor bearings of the variable condenser gang. It may be overcome by cleaning both parts with fine sandpaper or by revolving the dial several times to remove oxidization at that point.

BALANCING

When resonating the variable condenser system for most efficient receiver performance, it will be noticed that an entirely new and fool-proof system of locking the verniers has been employed. The large locking nut may be loosened with a No. 6 Spintite wrench and the vernier screw turned with a small pointed screw driver.

Proper method of balancing is accomplished by setting the antenna input control first on the No. 1 position. A station of low wavelength should be tuned to resonance on the dial. Adjust each trimmer condenser to exact resonance or so that it is set to peak volume. After this has been done, the input control should be set to the No. 2 position and the antenna section trimmer readjusted.

Upon completion, make certain that the wavelength of the station chosen corresponds to the proper wavelength reading on the drum dial.

ZENITH RADIO CORP.

MODEL BH (2021)
Schematic
Parts List

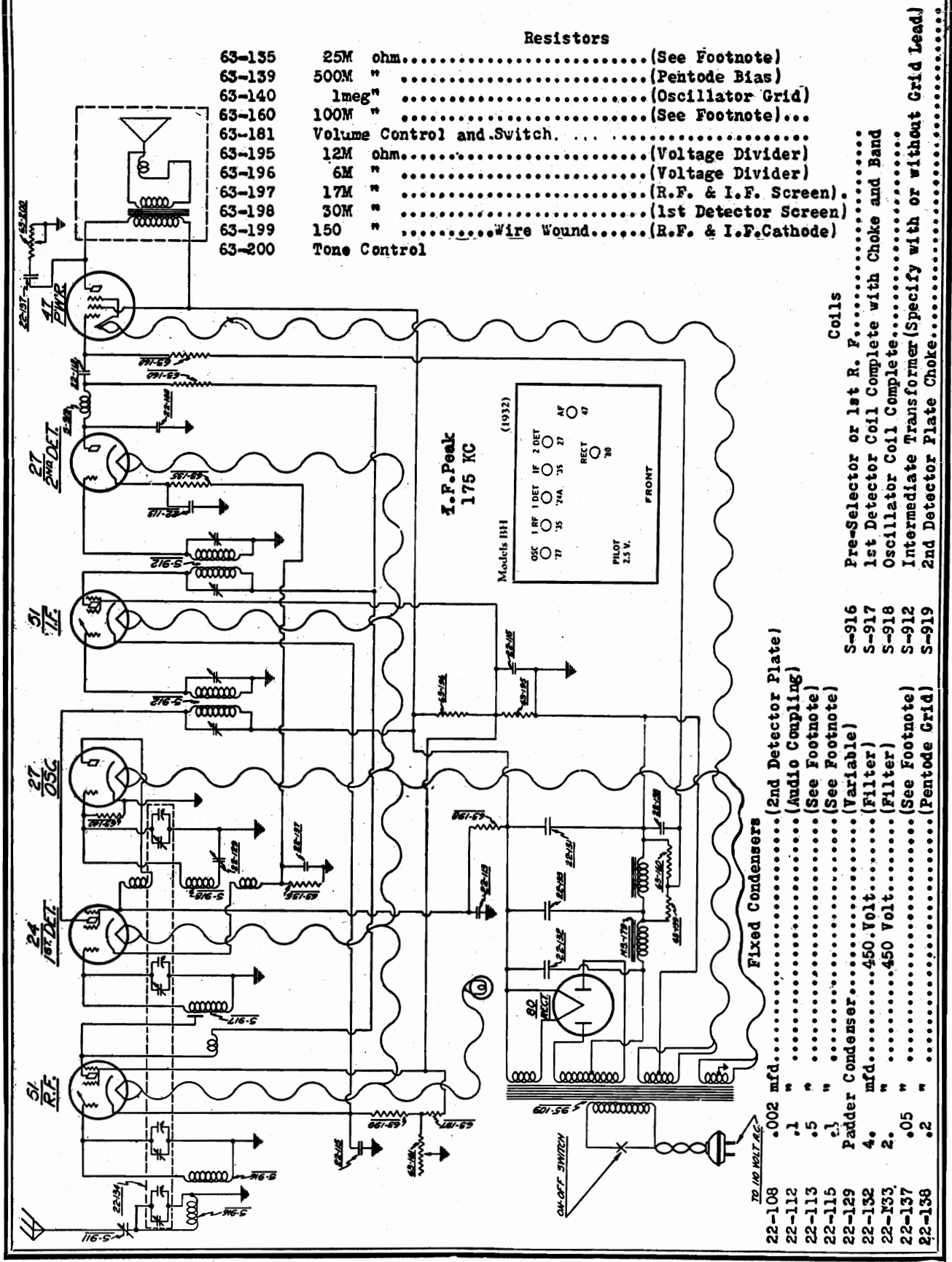

Resistors	
63-155	25M ohm.....(See Footnote)
63-139	500M "(Pentode Bias)
63-140	1meg"(Oscillator Grid)
63-160	100M "(See Footnote)...
63-181	Volume Control and Switch.
63-195	12M ohm.....(Voltage Divider)
63-196	6M "(Voltage Divider)
63-197	17M "(R.F. & I.F. Screen)
63-198	30M "(1st Detector Screen)
63-199	150 "Wire Wound.....(R.F. & I.F. Cathode)
63-200	Tone Control

Coils	
S-916	Pre-Selector or 1st R. F.....
S-917	1st Detector Coil Complete with Choke and Band
S-918	Oscillator Coil Complete.....
S-912	Intermediate Transformer(Specify with or without Grid Lead)
S-919	2nd Detector Plate Choke.....

Fixed Condensers	
22-108	.002 mfd.....(2nd Detector Plate)
22-112	.1 "(Audio Coupling)
22-113	.5 "(See Footnote)
22-115	1 "(See Footnote)
22-129	Padder Condenser.....(Variable)
22-132	4. mfd.....450 Volt.....(Filter)
22-133	2. "450 Volt.....(Filter)
22-137	.05 "(See Footnote)
22-138	.2 "(Pentode Grid)

MODELS LH,WH,MH (2022)

7 Tube Superhet
Schematic

ZENITH RADIO CORP.

Coils

- S-919 2nd Detector Plate Coil.....
- S-1179 R. F. Pre-Selector.....
- S-1180 Oscillator Coil.....
- S-1181 Detector Coil.....
- S-1185 2nd I. F. Transformer.....(175 K. C.)...
- S-1186 1st I. F. Transformer.....(175 K. C.)...
- S-1193 R. F. Plate Choke and Bracket.....

Fired Condensers

- .001 mfd... (2nd Detector Plate).....
- .5 " " (2nd Detector Cathode).....
- .1 " " (R.F. & I.F. Cathode).....
- .5 " " (R.F. & 1st Detector Screen).....
- 6. " " (Power Filter).....
- .05 " " (3 used, see footnote).....
- .2 " " (Power Grid).....
- 8. " " (Power Filter).....

Resistors

- 63-135 25M ohm... (1st, 2nd Detector Cathode)...
- 63-139 500M " " (Power Grid).....
- 63-140 1meg " " (Oscillator Grid).....
- 63-160 100M " " (2nd Det. Plate & Power Grid)...
- 63-199 250 " " (R.F. & I.F. Cathode, Flexible)...
- 63-207 10W ohm... (Voltage Divider, Wire Wound)...
- 63-208 12M " " (Voltage Divider).....
- 22-82 " " (2nd Detector Plate).....
- 22-113 " " (2nd Detector Cathode).....
- 22-115 " " (R.F. & I.F. Cathode).....
- 22-117 " " (R.F. & 1st Detector Screen).....
- 22-131 6. " " (Power Filter).....
- 22-137 .05 " " (3 used, see footnote).....
- 22-138 .2 " " (Power Grid).....
- 22-140 8. " " (Power Filter).....

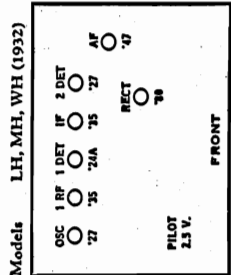
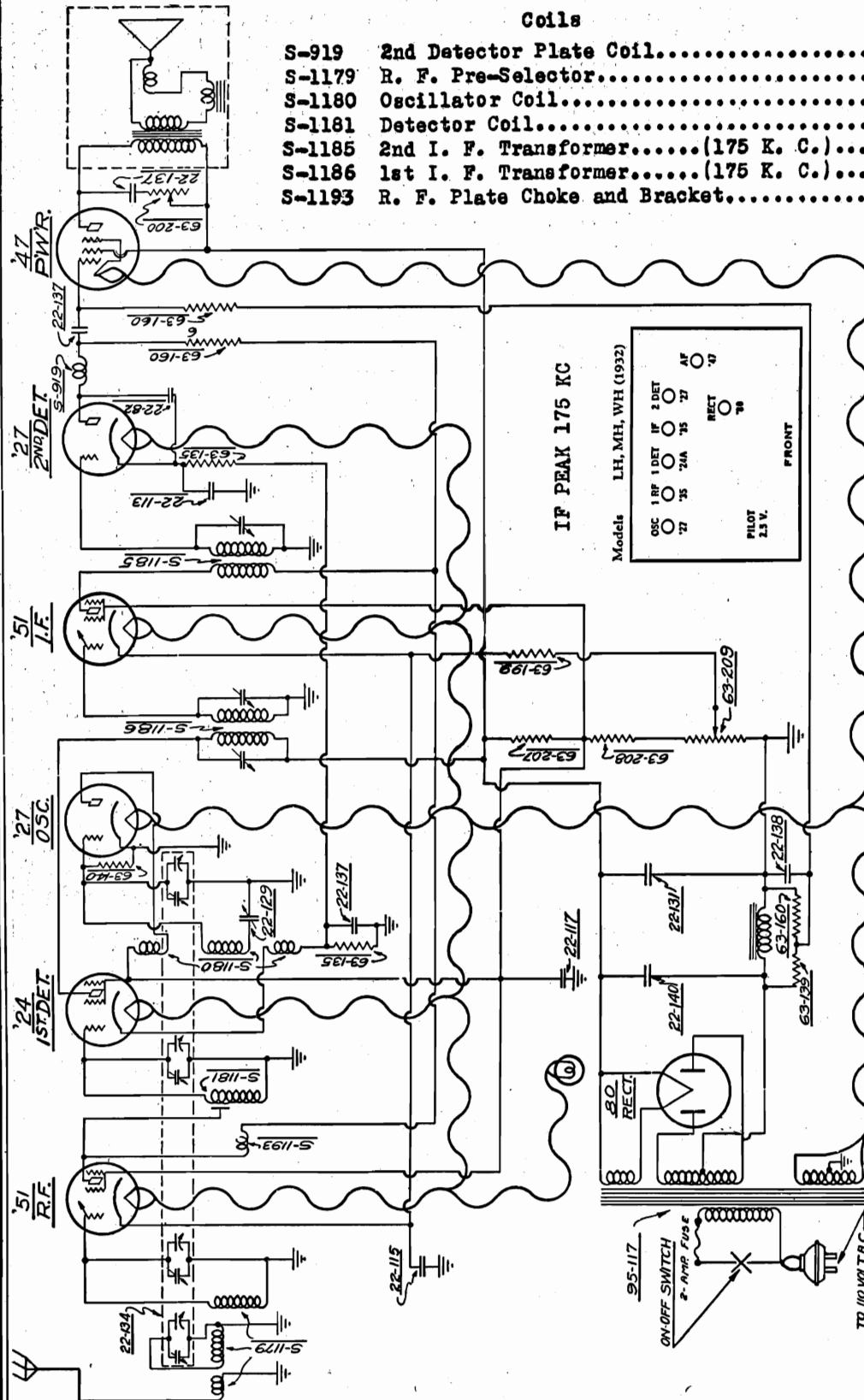

TO 110 VOLTS

ZENITH RADIO CORP.

MODEL 103
Chassis 2017
Above Serial # 450,451
Schematic

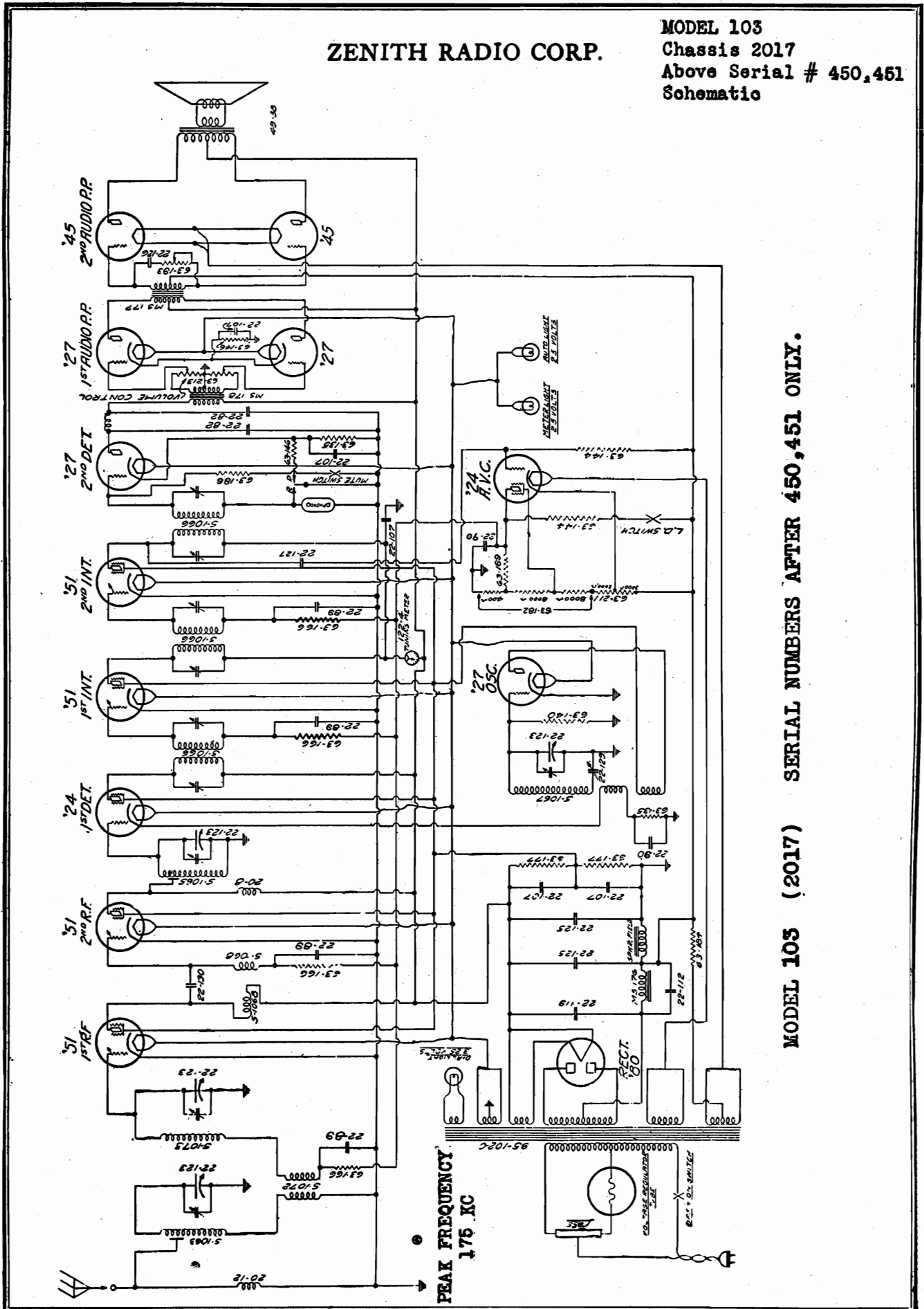

MODEL 103 (2017) SERIAL NUMBERS AFTER 450,451 ONLY.

PEAK FREQUENCY
1.75 MC

MODEL 103
Chassis Layout
Voltage

ZENITH RADIO CORP.

Socket Voltages

Type	Position	Fil. Volts	Plate Volts	Control Grid Volts	Cathode Volts	Plate M. A.	S. G. Volts
Z-51	1st. R. F.	2.2	185	- 9.	0.	2.5	80
Z-51	2nd. R. F.	2.2	200	- 3.9	0.	3.	84
Z-24	1st Det.	2.2	185	0.	+ 7.	.25	70
Z-27	Osc.	2.2	80	0.	0.	7.	0
Z-51	I. F.	2.2	185	- 4.	0.	3.	90
Z-51	I. F.	2.2	185	- 4.	0.	2.	90
Z-27	2nd. Det.	2.2	185	0.	+17.5	.5	0
Z-27	1st. P. P.	2.2	165	0.	+12.5	3.	0
Z-27	1st. P. P.	2.2	165	0.	+12.5	3.	0
Z-45	2nd. P. P.	2.3	240	-48.	0.	36.	0
Z-45	2nd. P. P.	2.3	240	-48.	0.	36.	0
Z-24	A. V. C.	2.3	30	- .4	0.	0.	45
Z-80	Rect.	5	350	0.	0.	70.	0
	Vol. Reg.	Con-	tin-	uity	test	only.	

Voltage readings taken with a Weston model 566 type 3 tester. Manual volume control in maximum position and antenna and ground disconnected. Line voltage 112

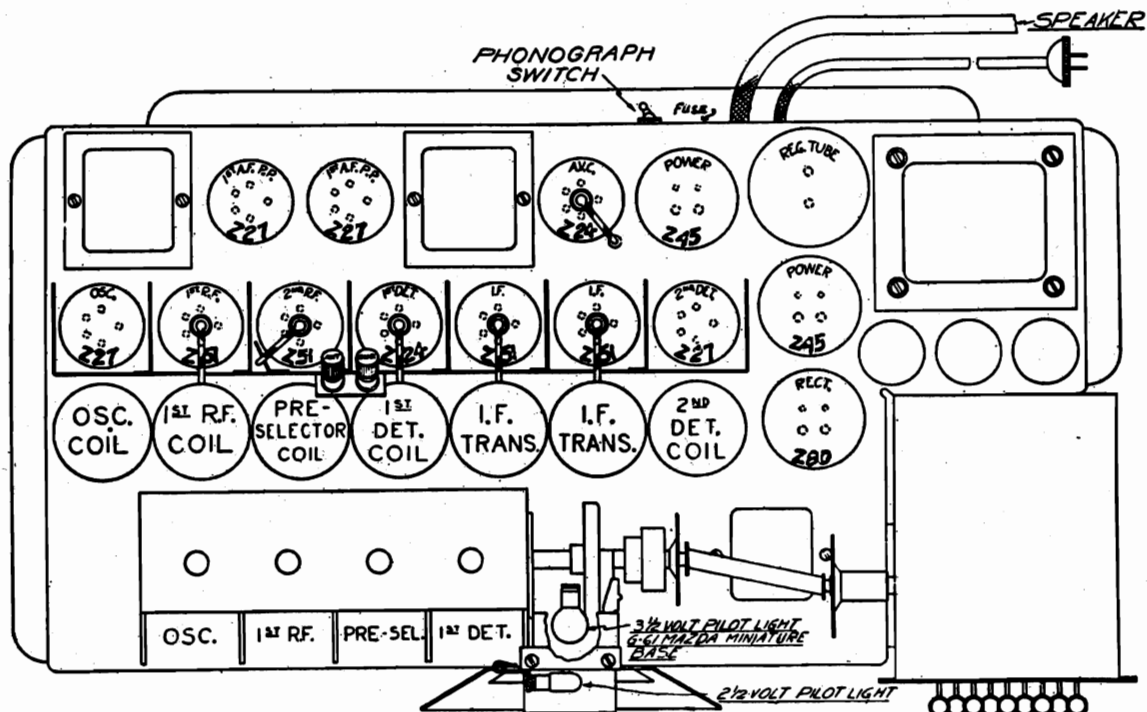

TUBE LAYOUT - Showing Position and Circuit Function of each.

ZENITH RADIO CORP.

MODEL 250,260,272
 Chassis 2031
 Schematic

Coils - Chokes

- S-919 2nd Detector Plate Choke
- S-1193 S.W. Detector Plate Choke
- S-2117 2nd I.F. Coil Assembly...
- S-2118 1st I.F. Coil Assembly...
- S-2161 Detector S.W. Coil.....
- S-2162 Oscillator S.W. Coil....
- S-2167 1st R.F. Coil Assembly...
- S-2169 Oscillator Coil L.W.....
- S-2171 1st Detector Coil L.W...

500M OHM	"	"	"	"	"	WATT
2M	"	"	"	"	"	"
100M	"	"	"	"	"	"
3M	"	"	"	"	"	"
150	ohm	"	"	"	"	watt
10M	ohm	"	"	"	"	"
12M	"	"	"	"	"	"
15M	ohm	"	"	"	"	"

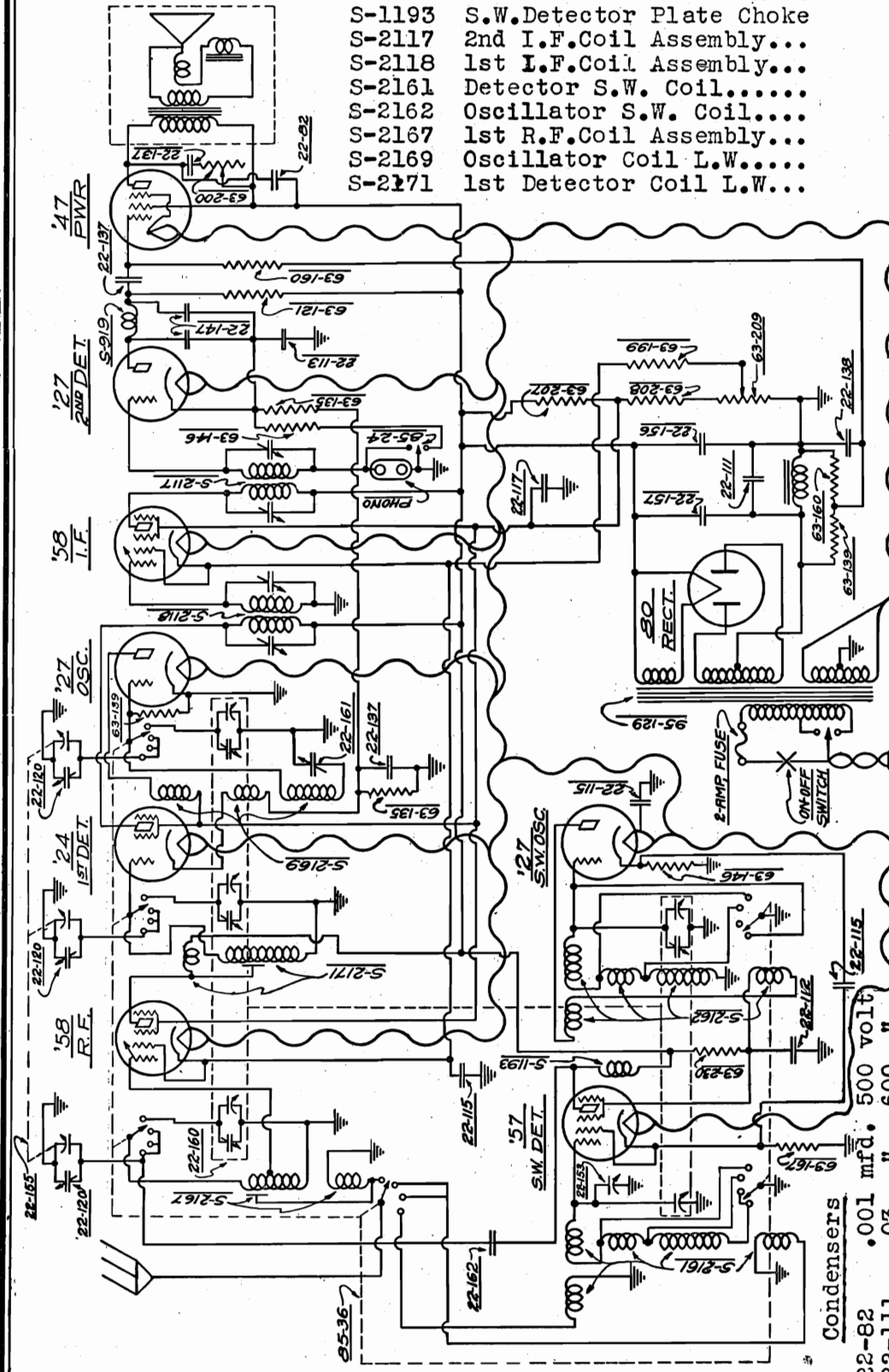

- 63-139 Three Gang Variable Trimmer
- 63-146 6. mfd. Electrolytic
- 63-160 8. " Electrolytic
- 63-167 .0001 mfd. 600 volt
- 63-199 100 ohm 1 watt
- 63-207 25M " " "
- 63-208 1 watt
- 63-230

Condensers

- 22-82 .001 mfd. 500 volt
- 22-111 .03 " " "
- 22-112 .1 " " "
- 22-113 .5 " " "
- 22-115 .1 " " "
- 22-117 .5 " " "
- 22-137 .05 " " "
- 22-138 .2 " " "
- 22-147 .0005 " " "
- 22-153 Short Wave Variable Trimmer

ZENITH RADIO CORP.

MODELS 500,501,503,514,
515,516,600,604,
606,610,616,618

Chassis 2037

Parts List

Resistors

63-121 100M ohm, 1 Watt (2nd Detector Plate).....
 63-135 25M " $\frac{1}{2}$ " (2nd Detector Cathode).....
 63-137 250M " $\frac{1}{2}$ " (Oscillator & Power Grid)..
 63-140 1 meg" $\frac{1}{2}$ " (A.V.C. Screen).....
 63-160 100M " $\frac{1}{2}$ " (A.V.C. Plate).....
 63-169 400M " $\frac{1}{2}$ " (A.V.C. Grid).....
 63-239 24M ohm 1 Watt (Oscillator Plate).....
 63-244 500 " $\frac{1}{4}$ " (1st Detector Cathode).
 63-251 Voltage Divider (six tap).....
 63-252 Voltage Divider (five tap).....

Coils and Chokes

20-30 Antenna Coil.....
 20-31 Oscillator Coil.....
 20-35 Detector Coil.....
 95-133 1st & 2nd I. F. Transformer.....

Condensers

22-112 .1 mfd 300 volt (2nd Detector Screen & Power Grid).....
 22-113 .5 "(R.F. 1st Detector & I.F. Grid Return).....
 *22-115 .1 " 200 volt (Four used, see below).....
 22-117 .5 "(R.F. 1st Detector, & I.F. Screen).....
 22-137 .05 " 400 volt (Oscillator Plate).....
 22-147 .0005 600 volt (2nd Detector Plate & A.V.C. Screen).....
 22-170 .1 mfd 400 volt (R.F. & 1st Detector Plate, 2nd Detector Plate)..
 22-171 .05 " 600 volt (Tone Control).....
 22-172 2. " 450 volt (Filter).....
 22-173 8. " 500 volt (Filter).....

Socket Voltages

Tube Type	Position	Fil. Volt.	Plate Volt.	Cath. Volt.	Screen Volt.	Supp. Volt.	Plate Current
Z-58	R.F.	2.4	190	0	95	0	7.
Z-58	1st Det.	2.4	190	2.3	95	2.3	4.
Z-56	Osc.	2.4	100	0	-	-	4.
Z-58	I.F.	2.4	190	0	90	0	2.
Z-57	2nd Det.	2.4	90	-60	70	-60	.2
Z-57	A.V.C.	2.4	-10	-65	-2	-65	0
Z-59	Power	2.4	175	-70	165	-70	25
Z-80	Rect.	5.	*350	-	-	-	*36

Line 115 Volts

All Controls Maximum

All readings, with exception of heaters, taken from socket connections to ground.
 Use 1,000 ohm per volt D. C. meter.)

BALANCE I.F. frequency at 175 K.C. Condenser gang at 1500 K.C. and oscillator
 padder at 600 K.C.

MODELS 500, 501, 503, 514,
515, 516, 600, 604,
606, 610, 616, 618
Chassis 2037
Schematic

ZENITH RADIO CORP.

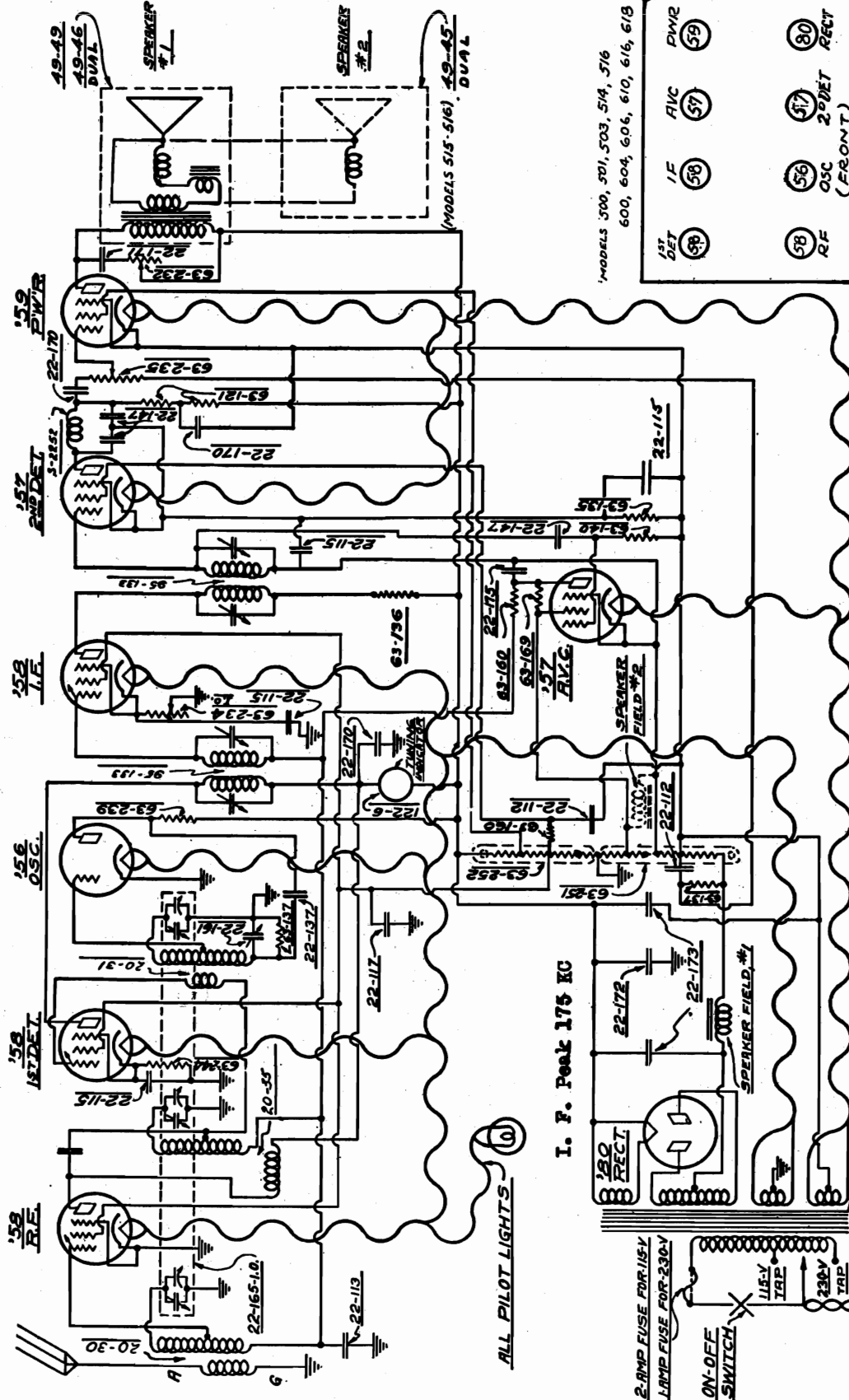

MODELS 500, 501, 503, 514, 516
600, 604, 606, 610, 616, 618

58	56	57	59
1 ST DET	OSC	I.F.	AVC
58	56	57	59
RF	OSC	I.F.	AVC
			PWV
			RECT

NOTE:
TUNING INDICATOR 122-6
NOT USED ON MODEL 516

95-147 60~
95-176 25~

TO 115-OR 230-VOLT A.C.

I. F. Peak 175 KC

ALL PILOT LIGHTS

2-AMP FUSE FOR 115V
1-AMP FUSE FOR 230V

ON-OFF SWITCH

115V TAP
230V TAP

SPEAKER FIELD #1
SPEAKER FIELD #2

120 RECT
80 RECT

22-172
22-173

22-117
22-115

22-112
22-118

22-119
22-120

22-121
22-122

22-123
22-124

22-125
22-126

22-127
22-128

22-129
22-130

22-131
22-132

22-133
22-134

22-135
22-136

22-137
22-138

22-139
22-140

22-141
22-142

22-143
22-144

22-145
22-146

22-147
22-148

22-149
22-150

22-151
22-152

22-153
22-154

22-155
22-156

22-157
22-158

22-159
22-160

22-161
22-162

22-163
22-164

22-165
22-166

22-167
22-168

22-169
22-170

22-171
22-172

22-173
22-174

22-175
22-176

22-177
22-178

22-179
22-180

22-181
22-182

22-183
22-184

22-185
22-186

22-187
22-188

22-189
22-190

22-191
22-192

22-193
22-194

22-195
22-196

22-197
22-198

22-199
22-200