

**RIDER'S VOLUME XVI**

# **HOW IT WORKS**

**AND**

**COMPLETE INDEX**



**John F. Rider Publisher, Inc.**

**404 Fourth Avenue**

**New York 16, N. Y.**

# TABLE OF CONTENTS

<b>F-M RECEIVING ANTENNAS</b> 1	<b>SPECIAL AVC CIRCUITS</b> 20
Voltage and Current Distribution — 1. Antenna Resistances — 2. Resonance and Impedance Relations — 2. Impedance Matching — 3. The Folded Dipole — 4. Orientation of F-M Receiving Antennas — 5. Dipole With a Reflector — 6. Length of Half-Wave Antenna — 7. Maximum Voltage Input — 8. Noise Reduction — 8. Indoor F-M Antenna RCA Model 68R1 — Farnsworth Model GK-140 — 9. F-M Antenna in G. E. Model 417 — 9.	Magnavox Model CR-183 — 20. Montgomery Ward Airline 74BR-1812A — 21.
<b>TELEVISION PICTURE MALADJUSTMENT OR INTERFERENCE</b> 10	<b>TUNING INDICATORS FOR F-M RECEIVERS</b> 23
<b>THE SELENIUM RECTIFIER</b> 13	Types of Tuning Indicators — 23. The Meter Indicator — 23. Operational Difficulties — 24. Stromberg-Carlson 1135-A — 25. Transfer of Tuning Indication Voltage — 26. Operation of Tuning Indication System — 26.
Installing Selenium Rectifiers — 14. Rectifier Tube Replacements in A-C Receivers — 14. Rectifier Tube Replacements AC-DC Receivers — 14. Rectifier Tube Replacements AC-DC Battery Receivers — 16.	<b>TELEVISION H-V POWER SUPPLIES</b> 28
<b>PRE-EMPHASIS AND DE-EMPHASIS</b> 17	Circuit Functions — 28.
Montgomery Ward Model 74WG-2505A — 19.	<b>BATTERY CHARGING CIRCUITS</b> 31
	A Rectifier Tube Battery Charger — 31. A Copper-Oxide Battery Charger — 34. Battery Economizer Circuit — 35.

Copyright 1947  
by  
John F. Rider

All rights reserved including that of translation into the Scandinavian and other foreign languages.

Printed in the United States of America

# F-M RECEIVING ANTENNAS

The advantageous features of f-m over a-m receivers in giving better reception and eliminating noise interference are quite well known. However, these favorable features can only be wholly realized if the proper f-m receiving antenna is employed. Some may dispute this point about the *necessity* of an f-m antenna, due to the fact that with straight pieces of wire very good reception of f-m has been attained. These cases are only of a special kind wherein the f-m receiver itself happens to be located in a very favorable region with respect to some of the f-m broadcasting antennas where the signal strength is high. In most other installations it has been shown that with the proper type of f-m aerial, f-m reception is definitely improved. If you are in doubt whether or not to use an f-m antenna in your locality and if you do not know too much about the surrounding terrain and where the f-m broadcasting antennas are located, then by all means it is definitely advisable to use an f-m receiving antenna.

The antenna generally used for f-m reception is a single half-wave dipole. In using such an antenna it is necessary to understand some of the important features relative to its proper orientation and hookup so that the correct type of reception can be obtained. In other words, the antenna has to be oriented in a certain direction in order to pick up the maximum amount of signal energy, and it has to be properly "impedance-matched" to the f-m receiver's r-f input section for the maximum transfer of energy. In order to understand the reasons why a half-wave dipole is used and why it is oriented in a special direction, it is necessary to understand something about current and voltage distribution and impedance matching in such an antenna, some other fundamental factors, and also about the radiation from f-m transmitting antennas.

## Voltage and Current Distribution

In choosing the type of antenna for f-m reception, as well as other types of reception, something should be known about how the voltage and current are distributed along the antenna. In this respect let us examine the voltage and current distribution along a full-

wavelength straight wire antenna as seen in Fig. 1.

The distribution is such that at the ends of the wire the current is a minimum and the volt-

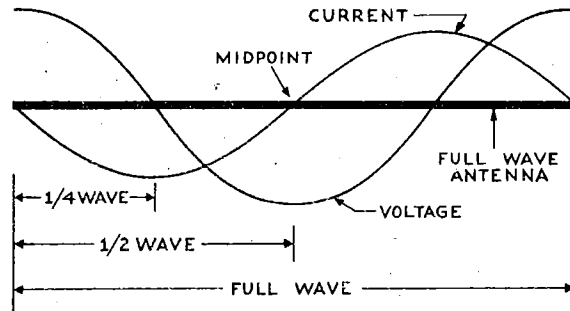

FIG. 1.—Voltage and current distribution along a full-wavelength straight wire antenna.

age a maximum. Since the voltage and current are represented by sine waves, it is evident that they change polarity at certain points along the full-wavelength wire. From the illustration, however, it is noticed that these changes in polarity of current and voltage do *not* occur at the same points.

The current is a maximum and the voltage zero at one-quarter of a wavelength from either end of the wire. Since the full wavelength of wire represents one complete cycle or 360 degrees of electrical length of either voltage or current, then under the circumstances of how the voltage and current is distributed these standing waves are said to be 90 degrees out of phase. Choosing any point along the wire and comparing the voltage and current waves, the 90-degree phase difference is the same as saying that the reversal of polarity of the current and voltage occurs  $\frac{1}{4}$  of a wavelength apart.

Now, let us just consider a half wavelength of wire or just half of the picture of Fig. 1. This half-wave wire is illustrated in Fig. 2 and is generally representative of the current and voltage distribution of the half-wave dipole antennas as used with many f-m receivers. A half-wave antenna is often referred to as being just a dipole antenna. The terminology of the word dipole originated from the fact that volt-

age distribution along the half-wave antenna is such that at the ends of the antenna the voltages are of opposite polarity (i.e., positive and negative charges). This is readily evident by the half cycle of voltage in Fig. 2.

Since the half-wave dipole antenna is the

FIG. 2.— Voltage and current distribution along a half-wavelength straight wire antenna.

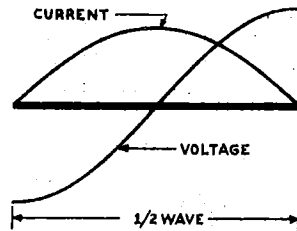

basic type used in f-m receivers, let us examine some of its characteristics as shown in Fig. 2. The current is seen not to change polarity and there is, ideally, zero current at the antenna ends with maximum current at the center of the dipole at  $\frac{1}{4}$  wavelength from either end. It is the voltage which changes polarity, and the change is such that there is, ideally, zero voltage at the center of the dipole or at  $\frac{1}{4}$  wavelength from either end. At the ends of the dipole the voltage is a maximum, but the voltage at one end is of opposite polarity to the voltage at the other end.

#### Antenna Resistances

All the power input to a transmitting antenna is dissipated in one form or another. The so-called *resistances* of an antenna determine how this power is dissipated. Any antenna, whether it is used for receiving or transmitting, contains two types of antenna resistance. One type is the usual ohmic resistance of the antenna often called the real resistance. The other type is often called the imaginary or radiation resistance. In other words, we are concerned with two types of power.

There is the power dissipated due to the actual ohmic resistance of the antenna and the power radiated from the antenna. The former power is readily understandable and from this the ohmic resistance is conceivable, but the resistance dissipating the latter portion of the power is not, in reality, a physical resistance in the sense that the other one is, and hence it is often known as the imaginary or radiation resistance of an antenna. Consequently, when

there is talk of power dissipation of an antenna, the  $I^2R$  total power loss should be understood to encompass both types of resistances. In other words, resistance  $R$  is the combination of the ohmic resistance of the antenna and the radiation resistance of the antenna.

In most types of antennas the ohmic resistance is much smaller than the radiation resistance, so that for practical purposes most of the power is considered to be dissipated through the radiation resistance. For a half-wave antenna the radiation resistance is often measured at the point of current maximum and for a half-wave dipole antenna in free space (i.e., no intervening objects including ground effects, building, mountains, etc.), the radiation resistance is found to be equal to approximately 73 ohms. This is only an ideal value which is never achieved and actual value varies somewhat away from 73 ohms depending on the exact length of the dipole and presence of other physical factors.

#### Resonance and Impedance Relations

Considering the simple half-wave dipole antenna that is center tapped, the antenna behaves like a series resonant circuit at this tap. This is shown in Fig. 3 where  $L$ ,  $C$ , and  $R$  represent the inductive, capacitive, and resistive components respectively. The resistive component is primarily the radiation resistance of the antenna, since the real or ohmic resistance is very small

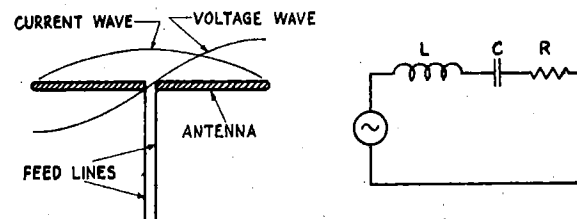

FIG. 3.—Center-tapped simple half-wave dipole antenna and equivalent series circuit.

even at the increased value it has at high frequencies.

If the dipole is approximately a half wavelength long, or about  $\frac{1}{4}$  wavelength on either side of the center tap, the antenna will act as a series resonant circuit to the frequency for which it is a half-wave antenna. For a series resonant circuit the impedance is a minimum

and purely resistive, the current a maximum, and the voltage a minimum. This is also seen in Fig. 2, where at the center point of the half-wave antenna, the current is a maximum and the voltage a minimum. At other points along the antenna the impedance is not purely resistive because it encompasses some reactance; therefore the impedance is greatest away from the center point, being a maximum at either end of the half-wave antenna, because of the minimum value of current and maximum value of voltage. The impedance of the antenna is a very important factor in the proper matching of the antenna to the transmission or feeder lines for the maximum transfer of energy from the antenna to the receiver input.

### Impedance Matching

In order to make sure that the maximum amount of energy pickup is transferred from the half-wave antenna to the receiver input, the antenna has to be properly impedance matched to the receiver input. A fair idea of impedance matching can be seen in Fig. 4. Looking in the direction of the input tube of the f-m receiver through the primary of the input transformer, we see an impedance equal to  $Z_1$ , and, looking in the direction of the transmission line and antenna, we see an impedance of  $Z_2$ . For maximum energy transfer,  $Z_1$  should equal  $Z_2$ . Under these conditions, the maximum amount of energy possible, not *all* the energy, will be transferred to

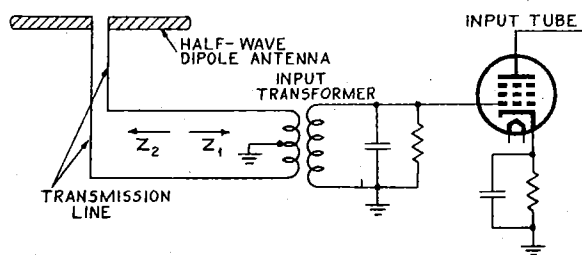

FIG. 4.—How a half-wave antenna is impedance matched to the receiver input.

the grid of the first f-m tube. For the complete match to occur, the transmission line should first be impedance matched to the antenna and then these units should match the input impedance of the first tube. The input transformer is the unit that takes care of this latter match. If

there is any mismatch, there will be a loss of energy and the maximum amount of energy possible will not be transferred.

As we have pointed out, the input impedance at the center of the half-wave dipole is a pure resistance and ideally equal to 73 ohms. In

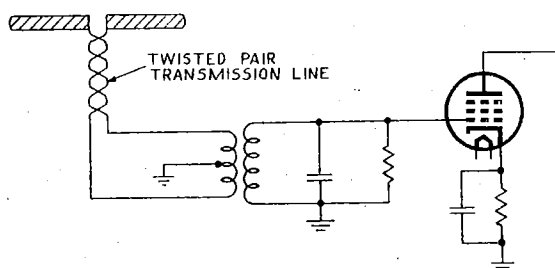

FIG. 5.—A simple impedance match for a half-wave antenna uses a twisted pair of transmission wires.

practice, this value of input impedance of the dipole can vary anywhere from 50 to 100 ohms due to varying physical factors, such as the construction of the antenna, the obstacles near the antenna, and its height. A very simple impedance match to such an antenna is made by using a twisted pair of transmission wires (usually, ordinary rubber-insulated wire) for the feeder section, as shown in Fig. 5. The so-called characteristic impedance of such a transmission line is approximately 75 ohms. By choosing different types of wire for the twisted line and by being able to vary the physical hookups to the antenna somewhat, the impedance of this transmission line can be varied on either side of this 75 ohms, for the desired impedance match. In addition to giving a good impedance match, this type of line minimizes pickup by the lead-in due to closeness of spacing between each individual wire, and thus noise pickup by the transmission line is reduced.

Under these circumstances where the antenna and line are properly matched, the input transformer of the receiver should have an impedance approximately equal to that of the line or antenna. That is, if the antenna resistance and characteristic impedance of this line is about 100 ohms, then looking *into* the primary of the input transformer, toward the first tube of the receiver, the impedance seen should also be 100 ohms. Under these circumstances the maximum

amount of energy transfer will be made from antenna to receiver.

Really, almost any good type of transmission line, in addition to the simple twisted pair, can be used to match the antenna as long as the characteristic impedance of the line is close to the radiation resistance of the antenna. Many receivers use f-m antennas supplied by outside manufacturers, and some receivers are not directly supplied with an f-m antenna, stating that an f-m antenna can be bought. Under these circumstances, the knowledge of the input impedance of the input transformer of the receiver is necessary in order to secure the proper impedance match. Many f-m receivers today have an input impedance equal to about 300 ohms, so that the transmission line and antenna used have to be properly matched to this 300-ohm impedance for proper energy transfer. Under these circumstances, transmission lines with a characteristic impedance of 300 ohms would normally be used to match the line to the transformer, but the 300-ohm line would be mismatched to, say, a 100-ohm simple half-wave dipole. In some instances, the f-m set may have an extra r-f stage or some other means where greater amplification can be attained and this amount of mismatch therefore can be tolerated.

There are, however, variations of the simple half-wave dipole antenna and variations in transmission line hookup so that impedance matching can be closely attained. There are folded dipoles, dipoles with reflectors, folded dipoles with reflectors, and specially constructed simple half-wave dipoles that change the effective radiation resistance. The analysis of some of these different types of f-m receiving antennas will be discussed later.

No matter what type of transmission line is used with any antenna, the smaller the length of the line, the fewer will be the line losses, no matter how well it is impedance matched. If the line *must* be long because of the location of the antenna, a low-loss transmission line should be used in order to prevent excessive reduction in the signal reaching the receiver.

#### The Folded Dipole

The folded dipole has a great advantage over the simple half-wave dipole antenna in that it exhibits a much higher input impedance. A folded dipole is nothing more than a simple

half-wave antenna as seen in Fig. 3, to which has been added another half-wave antenna section, joined at the ends.

A typical half-wave folded dipole is shown in Fig. 6. From this figure the folded dipole is seen

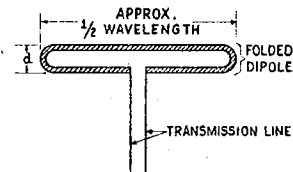

FIG. 6.—A typical half-wave folded dipole.

to be a full wavelength of wire (or appropriate tubing) but in such a manner that it approximately takes on the shape as seen in Fig. 6. The two open end parts are the effective center points of the folded dipole to which the transmission line is attached. This folded dipole is similar to an autotransformer in which the primary of the transformer is analogous to that part of the folded dipole which has the transmission line attached, and the secondary of the transformer is analogous to the other half-wave section of the folded dipole. According to this similarity, it is readily seen that a mutual impedance exists between the half-wave sections of the folded dipole in the same way that mutual inductance exists between the windings of a transformer. Since the folded dipole is center tapped, as shown, and since at this point the input impedance of this half-wave section is also considered as a resonant section, the impedance which is reflected into the center fed section from the other section, under this specific criterion, is resistive also. There are a few factors in the makeup of the folded dipole, as well as the simple dipole, which must be taken into account in order to make sure of this resistive input impedance. This will be seen later, but for most practical purposes the input impedance is considered to be predominantly resistive.

Now, since these two half-wave antenna sections of the folded dipole are attached to each other at the end points and since the distance *d* separating the two half-wave sections is much smaller than half-wavelength of the antenna section, the mutual impedance is considered to approach the maximum possible value. In other words, using the analogy of the transformer

again, the coefficient of coupling of the half-wave sections of the folded dipole is said to be approximately unity. Since each individual half-wave section has its own so-called self-impedance similar to the self-inductance of the windings of a transformer, the total *self-impedance* of both antenna sections (since they are connected) is equal to the sum of their individual self-impedances. The total self-impedance is not the complete impedance of the antenna because the antenna impedance, as a whole, takes into account the mutual impedance besides the total self-impedances. The type of wire or tubing used for each half-wave section is almost always the same material, so that the self-impedances of both half-wave sections are about the same, neglecting the small difference brought about by the slight spacing of that half-wave section to which the transmission line is attached.

For an autotransformer that has its windings wired in series aiding, the total inductance of the unit is equal to the sum of the individual self-inductances, plus twice the value of the mutual inductance. If the individual self-inductances are equal and if the coefficient of coupling is unity, then the value of the mutual inductance will be the same as either self-inductance. Under these circumstances, the total inductance of the autotransformer is equal to four times the self-inductance of one part of the winding.

The same thing is true, for most approximations, of the folded dipole. The individual self-impedances of the half-wave sections are about equal and the coefficient of coupling between these sections is considered to be unity, so that the mutual impedance is the same as either individual self-impedance. The total input impedance for this folded dipole is the sum of the individual self-impedances plus twice the mutual impedance. This means that the total input impedance of the folded dipole is equal to four times the value of either self-impedance. For the half-wave folded dipole these impedances are resistive, and thus it is said that the total input resistance of the folded dipole is equal to four times the input resistance of a single half-wave section of the folded dipole. Since a simple half-wave dipole antenna has approximately the same input resistance as a single half-wave section of the folded dipole, the input resistance of

a folded dipole is about four times as great as that for a simple half-wave dipole.

Under very favorable idealized conditions the input resistance of a half-wave dipole is equal to about 75 ohms. This means that under similar conditions the input resistance of the folded dipole is equal to 4 times 75 or 300 ohms. Thus we see that for f-m receivers having a 300-ohm input impedance, a 300-ohm transmission line can be used to match the folded dipole to the receiver for maximum energy transfer.

#### Orientation of F-M Receiving Antennas

According to the regulations of the FCC, the f-m broadcasting transmitting antenna must be horizontally polarized. Since the frequency of transmission is quite high, radiation from the transmitting antenna must be horizontally directive because of the bad effects of the atmospheric sky layers and ground which absorb and attenuate high-frequency signals. Because of the horizontally directive properties of radiated f-m signals, the f-m receiving antenna should be oriented in as best a horizontal position as possible in order to pick up the maximum amount of signal energy. There are special cases where the FCC allows polarization other than directly in the horizontal plane, but these cases are few in number. If such a transmitting station does exist in your neighborhood, then the receiving antenna should be oriented in a slanting or diagonal manner so that both horizontally polarized and vertically polarized signals can be picked up adequately.

For horizontal polarization, the electric field (electrostatic lines of force) of the transmitting signal is parallel to the ground or horizontal. This means that the receiving antenna has to be horizontally positioned in order that the passing signal may induce the maximum possible voltage in it. Horizontal polarization is more favorable than vertical polarization because certain interference phenomena, such as ignition interference, is often polarized very strongly in a vertical direction. This means that the use of horizontal polarization enables the f-m receiving antenna to have a better signal-to-noise ratio. In other words, the horizontal orientation of the antenna helps the antenna discriminate against noise in favor of the signal pickup.

The receiving antenna should be oriented in

the direction of the f-m transmitting antenna to be able to receive the maximum adequate signal pickup from the directive antennas. Since a number of f-m stations cover the same area but are located in different places, the amount of signal pickup by the receiver antenna will differ for the various f-m stations. The receiving antenna should be placed broadside to the directed rays of the transmitting antennas for which the signal pickup is the weakest. In this way the receiving antenna serves its most useful purpose in trying to obtain as best as possible equalized signal pickup on all of the f-m stations in its area.

### Dipole With a Reflector

In many localities where the receiver is located, the f-m signal pickup required for proper reception is greater than that of a half-wave dipole or folded dipole antenna so that something has to be done to increase the signal pickup. Since the antenna is in an area where the signal horizontally surrounds it, one can well realize that signal energy exists at points other than just around the dipole itself. This is a natural understanding and leads us to the idea that if some of this signal energy from the surrounding area could be effectively directed toward the antenna itself, then the antenna would effectively have a greater signal input. This is especially necessary when the receiver is located a great distance away from the transmitting antennas and when the signal pickup is weak for the half-wave dipole.

In order to increase this signal pickup effectively the antenna employed is equipped with a "reflector" element. This is shown in Fig. 7

FIG. 7.— Simple half-wave dipole equipped with reflector element to increase signal pickup.

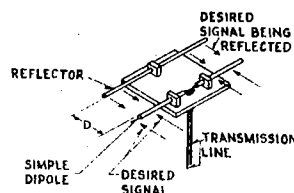

where a simple half-wave dipole is used, and placed behind this dipole and in the same plane of the dipole is the reflector element. This reflector conductor is usually of the same material as the dipole itself, and in practice it has been found that the reflector should be slightly longer than the length of the dipole used. The reflector should be placed on that side of the

receiving dipole *away* from the transmitting antenna whose signal it is desired to receive. This means that the desired signal will be approaching the antenna dipole in the direction indicated in Fig. 7. That part of the signal that passes the dipole and hits the reflector conductor will be reflected back to be picked up by the dipole.

The distance  $d$  that the reflector is spaced from the dipole is a criterion in the amount of increased signal pickup, and it will usually be somewhere from  $\frac{1}{10}$  to  $\frac{1}{4}$  of a wavelength away from the feed-in dipole element. Most manufacturers specify the spacing in their service instructions accompanying the antenna. The reason for the certain amount of spacing is to make sure that the reflected signal that is picked up by the receiving dipole is *aiding* the signal directly picked up by the same dipole so that the maximum possible total energy pickup is available.

The way in which the signal is increased can also be explained in the manner of transformer action. In other words, there also exists a certain amount of mutual impedance between the dipole and reflector determined primarily by the distance separating the elements and self-impedance of the elements. In brief, then, when the signal hits the reflector a voltage is induced in it which causes a corresponding current in the reflector. This reflector current by analogous transformer action induces a voltage into the lead-in dipole element, the exact amount depending upon the mutual impedance, and the phase relation of the voltage depending upon the spacings between the elements, which is often  $\frac{1}{4}$  wavelength apart. Thus it is seen how the receiver antenna with a reflector can have an effective increase in signal pickup over a half-wave antenna without a reflector.

Since the mutual impedance exists between the elements and since the signal pickup is increased, the effective input impedance is also increased. The exact value of increased input impedance depends upon the degree of coupling and hence the value of mutual impedance between the elements. When used with a simple half-wave dipole antenna or folded dipole, the reflector will increase the input impedance, so that in addition to increasing the signal pickup the reflector can change the input impedance for perhaps a better impedance match.



When used with a reflector, the half-wave antennas become unidirectional in that there is very little signal pickup from the reflector side of the arrangement.

#### Length of Half-Wave Antenna

So far we have described the length of the antenna as a half-wavelength and similar nomenclature. What is most desired to be known is the actual physical length of the antenna and why the particular length is chosen. If only one frequency is going to be picked up (i.e., for a fixed frequency f-m receiver) then the antenna length is easy to calculate and is based on that signal frequency. However, we are mainly concerned with broadcast f-m receivers. The f-m broadcast band of today is between 88 and 108 mc and the antenna length must be chosen so that it will be responsive to all frequencies in this band. Since in many instances some transmitting signals are much stronger than others, the design length should favor the weaker stations. For most practical purposes, however, the half-wavelength of the antenna is designed at the center frequency of the band of frequencies it is to receive. This means that in the f-m broadcast band the design of antenna is made at 98 mc.

It is well known that a 10-meter wavelength means a frequency of 30 mc, but the simple formula used to derive it is often forgotten. The wavelength of a specific frequency is found by dividing this frequency into the *velocity of radio waves*. The velocity of radio waves is equal to 300,000,000 meters per second and thus with the frequency,  $f$ , in cycles per second, the wavelength in meters is given by the following:

$$\text{Wavelength} = \frac{300,000,000}{f} \text{ in meters}$$

This is for one full wavelength. If we change the units of this formula and divide the right hand side by 2, we will find that

$$L = \frac{492}{f(\text{mc})} \text{ in feet, or}$$

$$L = \frac{5904}{f(\text{mc})} \text{ in inches}$$

where  $L$  is equal to the length of a *half wave-*

*length* in free space and  $f$  is the frequency in megacycles per second.

In half-wave antennas there is a so-called "end effect" due to the material supporting the antenna and other physical construction which makes a true half-wavelength antenna actually electrically longer than it is. In order to make sure that the electrical length of the antenna used is *effectively* one-half wavelength long, the actual physical length is made less than that for a half wave in free space which has no end effects. The effective length of the antenna increases with increase in frequency because the end effect also is increased. From about 5 to 30 mc, the physical length of the half-wave antenna should be reduced by about 5 per cent to make it effectively operate as a half-wave antenna. Since the frequency of operation of the f-m band today has a center frequency of about 100 mc, the effective length would increase, which means that the physical length should be reduced by more than 5 per cent. For most practical purposes at these high f-m frequencies and taking into account other factors, the physical length of the half-wave antenna should be reduced by about 7.5 per cent. This means that the preceding formulae have to be multiplied by 92.5 per cent to give the correct effective half wavelength. Thus,

$$L = \frac{492 \times .925}{f(\text{mc})} = \frac{455}{f(\text{mc})} \text{ in feet, or}$$

$$L = \frac{5904 \times .925}{f(\text{mc})} = \frac{5460}{f(\text{mc})} \text{ in inches}$$

where  $L$  is equal to the effective length of a *half-wave antenna*.

Therefore, for most center lead-in half-wave antennas each half of the dipole is approximately equal to half the values of  $L$  found in the foregoing formulae. For instance, in the f-m broadcast band the center frequency is 98 mc. This means that the length of the half-wave dipole antenna should be as follows:

$$L = \frac{455}{98} = 4.64 \text{ feet, or}$$

$$L = \frac{5460}{98} = 55.7 \text{ inches}$$

Since each section of the dipole is *effectively* a quarter wavelength long, the actual physical

length is  $\frac{4.64}{2}$  or 2.32 feet, or  $\frac{55.7}{2}$  or 27.85 inches long. In actual practice the lengths of the individual sections of the half-wave dipole will be somewhat smaller than that computed above due to the *gap* occupied by the transmission line.

### Maximum Voltage Input

It is well known that a maximum voltage input to the receiver is desired but yet the feed-in to the half-wave antenna or folded dipole is center driven and at this point the *current* is effectively at a *maximum*. How then can we conceive of a maximum voltage to the first f-m tube? There are numerous ways of explaining this, but one of the simplest methods is through the understanding of the impedance of a parallel circuit.

In Fig. 8 a dipole antenna and input circuit to an f-m receiver is illustrated along with the

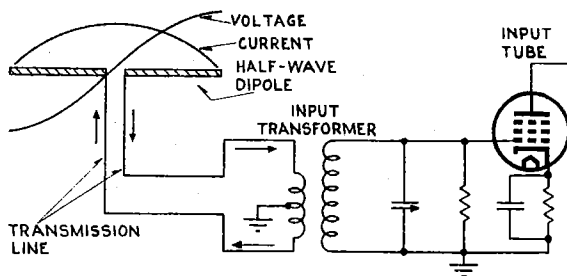

FIG. 8.—Dipole antenna and input circuit to an f-m receiver with current and voltage curves effective at the dipole.

current and voltage curves effective at the dipole. Since the center point of the antenna is at the loop of the current curve, a maximum amount of current will flow through the primary of the input transformer. This maximum amount of current sets up a maximum magnetic field which causes a maximum flow of current in the secondary due to induction. Since the parallel tuned secondary circuit is resonant at the frequency of operation, it will offer a maximum amount of impedance, which is purely resistive. Since the current flowing in the secondary is a maximum and the impedance also a maximum, the *voltage drop* across the grid of the input tube will likewise be a maximum because the voltage is equal to the

product of the maximum current and maximum impedance.

### Noise Reduction

In many f-m antenna systems the primary of the input transformer often has its center point grounded in order to reduce noise interference through the medium of the transmission line. Many of the f-m circuits appearing in the Rider Manual Vol. XVI, as well as other Rider Manuals such as Vol. XV, contain this arrangement. This was illustrated in Fig. 8 but the left hand side of this figure is redrawn in Fig. 9 to make this system of noise reduction somewhat clearer. Since the transmission line used (no matter what type) covers a greater area than the antenna itself, it has a tendency to pick up noise voltages. This is especially so if the transmission line is quite long. In order to reduce this noise pickup and hence increase the signal-to-noise ratio to the input to the f-m receiver, the center tap of the primary is grounded. It effectively does away with this noise in the following manner:

The noise signal when it hits the transmission line induces equal voltages in each lead of the transmission line which in turn produces noise current that flows in the same direction in the transmission line as indicated in Fig. 9. By center tapping the primary of the input transformer to ground, the circuit becomes symmetrical and the noise currents both flow toward this ground connection. This effectively makes the individual currents out of phase, and since they are equal in magnitude they effectively produce magnetic fields which

FIG. 9.—Grounding the center point of the primary of the input transformer reduces noise interference through the medium of the transmission line.

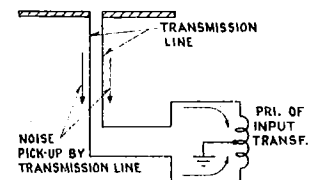

cancel each other. Hence, the total noise voltage induced in the secondary of the input transformer is effectively zero.

This reduction in noise pickup is only in reference to that picked up by the transmission line and not that noise inherently picked up by

the dipole itself. This latter noise finds its way into the receiver as well as the desired signal input, but accordingly this noise is small and if it just changes the amplitude of the received signal, the f-m receiver will take care of these amplitude variations in the f-m signal by either limiting their variations or not responding to them at all.

#### Indoor F-M Antenna RCA Model 68R1— Farnsworth Model GK 140

Although it is best to have the f-m receiving antenna mounted on top of a building or structure, and as high as possible, there are instances where using an outdoor antenna is not possible or is impractical. Due to such circumstances, many f-m receivers are manufactured with f-m *indoor* antennas similar to the way loop antennas are used in a-m sets. These antennas are in one form or another similar to those previously discussed. For instance, in the RCA Model 68R1, etc., which appear in Rider's Vol. XVI, a folded dipole is inserted inside the cabinet. However, it should be remembered that the f-m signals are directional and in many instances it may be necessary to orient the cabinet until the best reception is heard on all stations. If reception is weak and noisy using this indoor antenna, RCA manufactures an outdoor f-m antenna of the dipole and reflector type (stock No. 225) which will afford much better reception than the indoor antenna.

In the Farnsworth f-m receivers Models GK 140 to GK 144 also appearing in Rider Vol. XVI, an indoor antenna modified in the form of a folded dipole is now used. A diagram of this folded dipole arrangement is shown in Fig. 10. To make this antenna arrangement about 5 ft of Amphenol 300-ohm twin lead is used with some of the polyethylene plastic insulator stripped away from the ends. Next, the two leads on each end are twisted together and then soldered as shown in Fig. 10. The next step is to cut away a portion of the insulation around one lead in the middle of the dipole, equal to the width of the twin lead and then cut and bend the bare lead so that two bare pieces of the wire protrude. This part of the antenna represents the folded dipole. Next, take another piece of the same Amphenol 300-ohm twin lead and strip off some of the plastic insulator at one end so that the two leads are

bare. Solder these two bare leads to the two of the center part of the folded dipole as shown in Fig. 10. This latter twin lead represents the

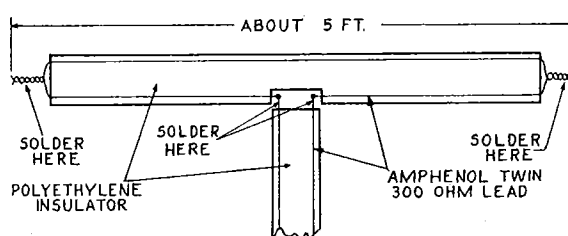

FIG. 10.—Farnsworth indoor antenna modified as a folded dipole.

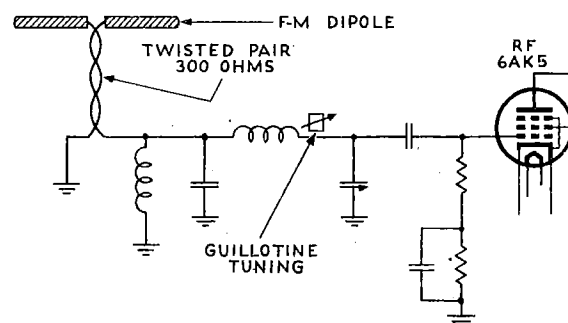

FIG. 11.—Schematic diagram for the G. E. Model 417 dipole antenna to the r-f input circuit.

transmission line, and it should be the length that will make its wiring to the receiver input most favorable.

This type of a folded dipole construction is more suitable for indoor antenna use and not outdoor where the construction must be more rigid.

#### F-M Antenna in G.E. Model 417

The majority of f-m receivers as seen in Rider's Vol. XVI (and also Vol. XV) use or make mention of the need for an outdoor f-m antenna. In the General Electric Model 417 a simple half-wave dipole antenna is used, to which is connected a 300-ohm twisted-pair transmission line. The schematic for this is shown in Fig. 11 and is easily noticed in the 88 to 108 mc f-m band of the "clarified schematic," General Electric page 16-19 of Rider's Vol. XVI. The dipole and transmission line used give a good impedance match to the input receiver circuit for the desired energy transfer for good reception.

# TELEVISION PICTURE MALADJUSTMENT OR INTERFERENCE

The reproductions of the test pattern as seen on a television receiver screen in the following illustrations, will serve as a guide to the serviceman for the correct installation of antenna systems, or when he is ready to install a receiver, to make a final check of any service work he has done.

As will be seen, some of the patterns (Figs. 1 through 4) result from incorrect adjustment of the tuning control which are operated by the owner of the receiver. Figs. 5 through 10, are due to some misadjustments of pre-set controls,

which are under the control of the installer or the serviceman. Figs. 11 through 15 are due to incorrect placement of the receiving antenna, incorrect adjustments of components in the receiver, or strong local interference.

The typical abnormalities of the test pattern which are shown in these illustrations, are common to all television receivers, and the measures used to correct these troubles will be similar in all cases.

These figures are reproduced through the courtesy of the General Electric Company.

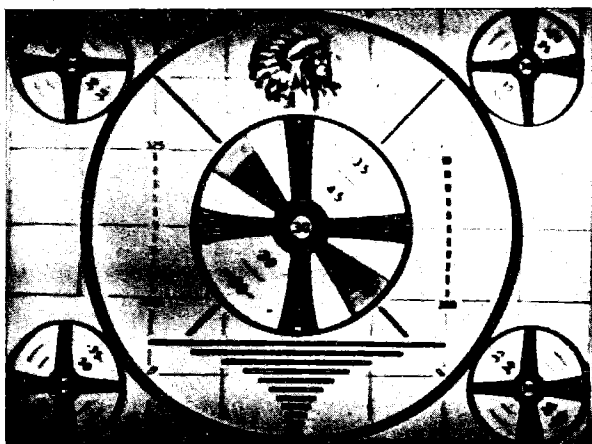

FIG. 1.—Normal picture: The separation between the lines of the resolution wedges is sharp and four gradations from white through gray are well defined, the circles in the center of the pattern are symmetrical.

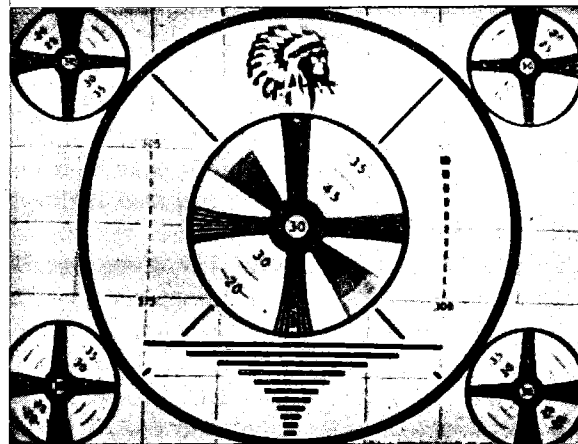

FIG. 3.—Contrast too high: Too low brilliance destroys the definition, deepens the blacks so that only black and white are seen.

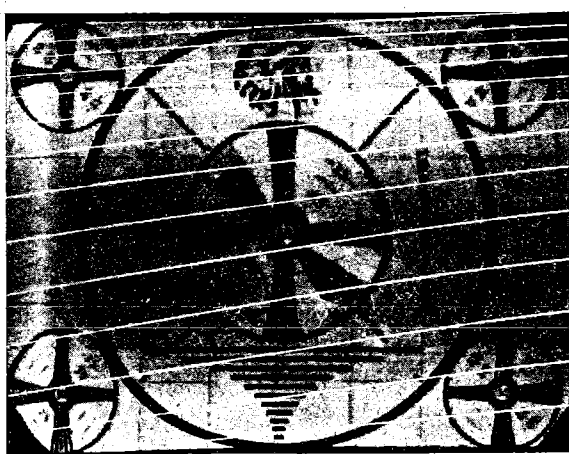

FIG. 2.—Contrast too low: Note that due to the too high brightness the clear definition in the wedges is lost and all the blacks have grayed out.

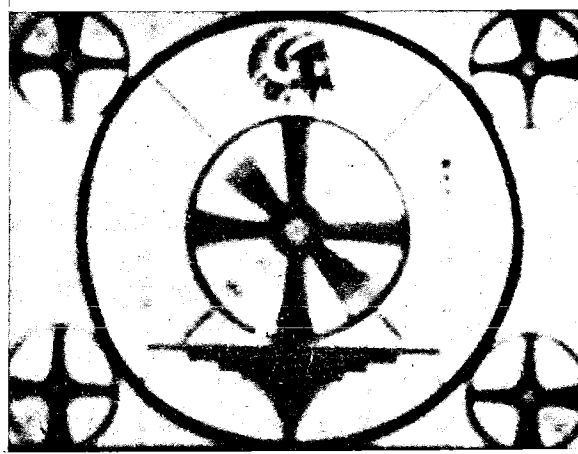

FIG. 4.—Focus control misadjusted: The whole pattern becomes fuzzy and except at the outer edges there has been a graying of the entire pattern.

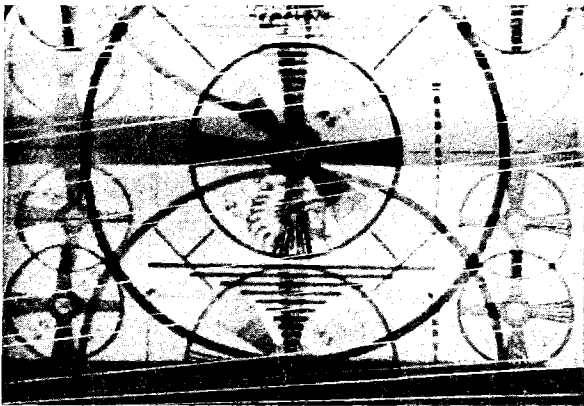

FIG. 5.—Vertical hold misadjusted: This causes the pattern to travel so that it is seen moving up or down the screen and overlapping.



FIG. 8.—Horizontal hold control misadjusted: The test pattern leans to right or left on the screen.

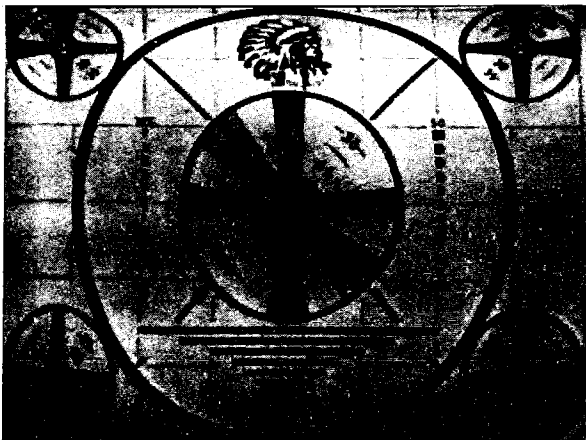

FIG. 6.—Vertical linearity control misadjusted: The test pattern is out of true and is bunched at the top or bottom of the viewing screen.

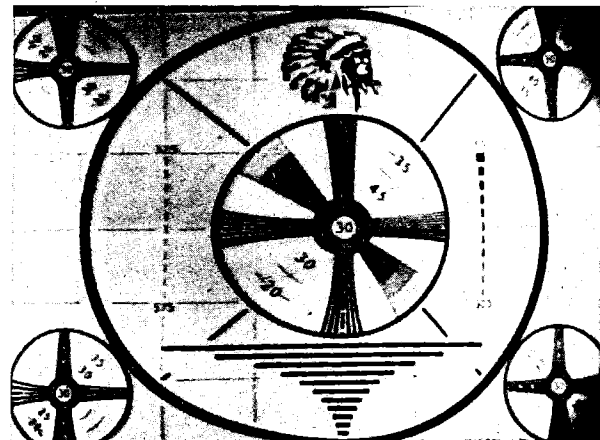

FIG. 9.—Horizontal linearity control misadjusted: The pattern is unsymmetrical and the circles and wedges are elongated either to the right or left.

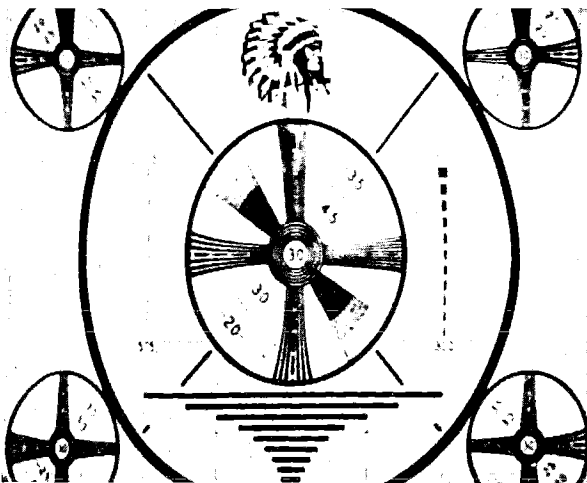

FIG. 7.—Vertical height control misadjusted: The test pattern is elongated vertically and the circles are cut at the top and bottom of the screen.

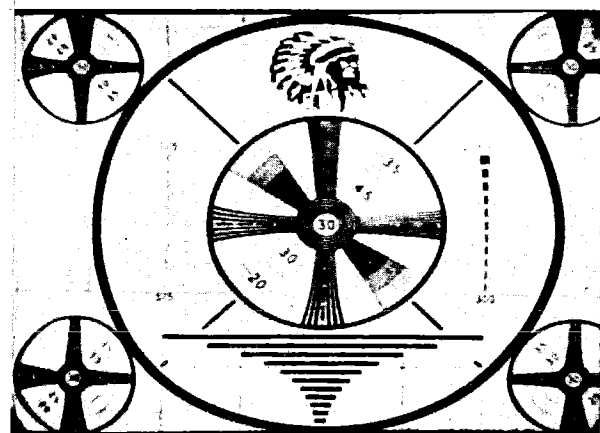

FIG. 10.—Horizontal width control misadjusted: The test pattern tends to bulge to either side and appears to flatten out at the top and bottom.

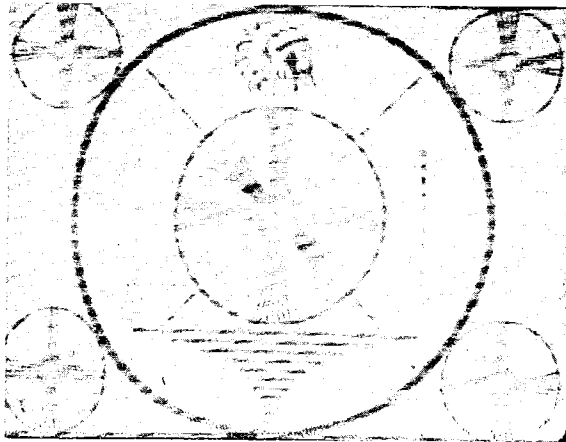

FIG. 11.—R-F interference pickup on antenna: This is indicated by an overall fuzziness caused by bars of alternate black and white angling across the screen—re-location of the antenna may be indicated.

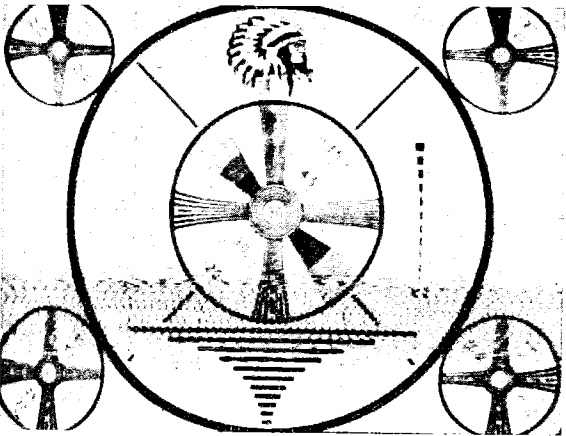

FIG. 12.—Weak diathermy interference: This interference pattern is shown as a band of small interwoven circles across some portion of the screen. Re-location of the antenna may clear this up—if not the offending equipment must be located and isolated.

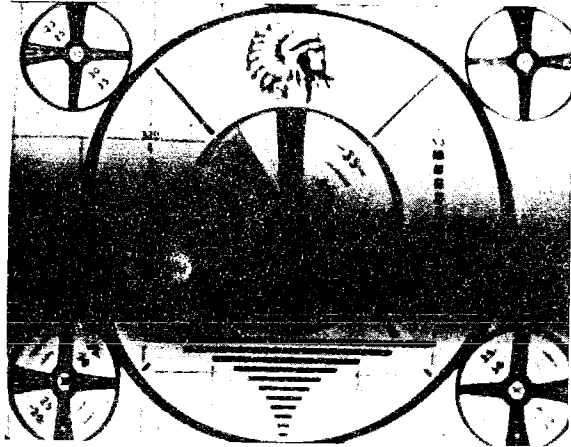

FIG. 13.—Strong diathermy interference or hum in video i-f, detector, or video output: This interference is seen as a very intense black smudge of varying width across the body of the pattern—re-location of the antenna may clear this up—if not the offending equipment must be located and isolated. The hum may be caused by leakage in one or more of the power supply circuits.

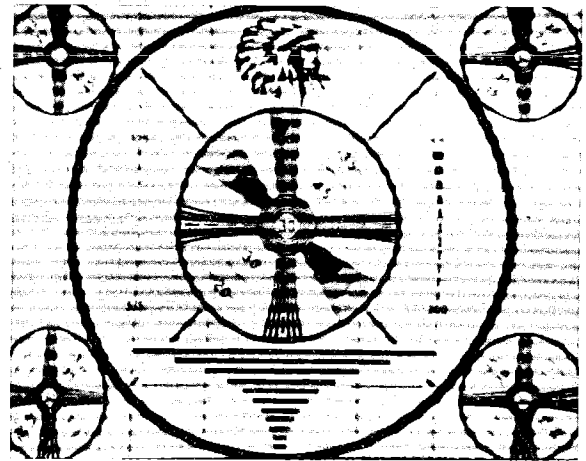

FIG. 14.—Sound bar interference or microphonics: This pattern appears the same as the interference shown in Fig. 11 with the exception that it will be in horizontal lines. This may be bad tubes, disarrangement of dressed leads—also may require re-location of antenna.

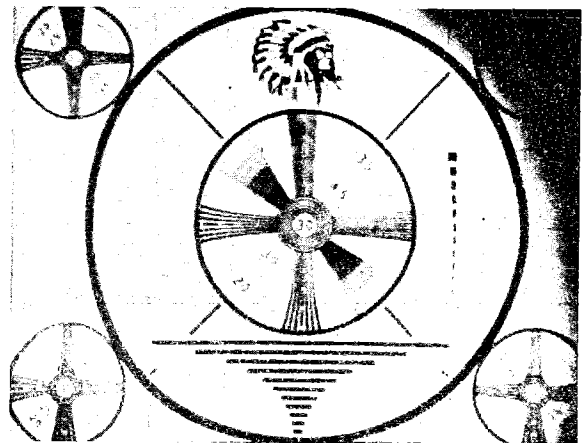

FIG. 15.—Ion trap or focus coil not properly adjusted: A black area will be seen in one of the corners of the screen or the entire test pattern will be at an angle. Deflection coils not properly centered on vertical and horizontal plates—ion trap is not adjusted properly to remove all stray electrons due to secondary emission from the graphic coating of cathode-ray tube.

# THE SELENIUM RECTIFIER

The selenium rectifier is gradually replacing the familiar rectifier tube in ac-dc sets, and unless some unforeseen difficulty arises, its numerous advantages should make for universal replacement. In a new receiver the selenium rectifier is very small, light, and easy to install; for an old receiver requiring the replacement of a burned out rectifier tube, it has the selling point of long life (the claim being for the life of the receiver) and rugged all-metal construction. In both cases, there is also the advantage of cool operation and the elimination of the warm-up period. It is not affected by temperature or altitude extremes, or by shocks and vibrations. There are no moving parts or chemicals, and it is absolutely silent in operation.

The operation of the selenium rectifier is easily understood. Its rectifying action depends on a property often found at a junction of two dissimilar metals, i.e., that electrons flow more readily in one direction than in the opposite direction.

The typical unit found in new receivers consists of several small plates, usually square in form, stacked together at their centers, and utilizing two lugs for connection to the circuit. Each element is simply a supporting aluminum plate, coated on one side with selenium, and then having a metallic coating over the selenium. This selenium "sandwich" ensures adequate electric contact with both sides of the selenium. By proper heat processing, a rectifying film is formed between the selenium and the metallic coating. The metallic coating has a great number of free electrons that can flow through the selenium, and into the aluminum plate. However, the selenium has very few free electrons available, so that the electron flow in the opposite direction is very limited.

FIG. 1.—The electron flow through a selenium rectifier is from the metallic coating-selenium surface towards the aluminum plate, as indicated by the arrow.

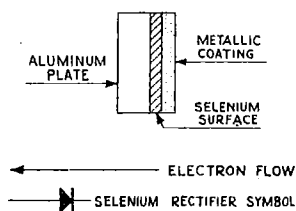

If the negative terminal of a power source is connected to the metallic coating, the flow of

current toward it is very small, for we have seen that there are few free electrons available. Consequently, the electron flow in Fig. 1 is from right to left. The symbol used to represent the selenium rectifier and similar types, shown in Fig 1, was adopted before the electron flow theory was accepted, but has never been revised. Therefore, when a selenium rectifier replaces a diode rectifier in a circuit diagram, the corresponding terminals are as indicated in Fig. 2.

FIG. 2.—In the schematic symbol for the selenium rectifier at the right, the electron flow is from 2 (identified by a red dot) upwards to 1 (identified by a yellow or no dot).

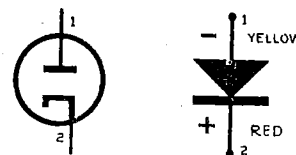

The selenium rectifier most commonly met with today is the Federal Type 403D2625, which has a maximum d-c output of 100 ma and a drop of 5 volts across it. The two lugs may be marked positive and negative, or they may be color coded; positive is indicated by a red dot, negative by a yellow dot or blank, as in Fig. 2. Care must be taken that the proper polarity connections are made, remembering that B+ is obtained from the *cathode* of the rectifier tube and so the positive lug (red dot) must be where the cathode was formerly connected.

If the selenium rectifier is inserted in a circuit where the tube resistance is needed, it is necessary to supply additional series resistance to compensate for the low resistance of the rectifier. Further, since the tube filament is no longer used, a circuit utilizing it (such as most ac-dc sets with filament strings) must have a resistor added as well as the selenium rectifier. The succeeding paragraphs illustrating the replacement of a rectifier tube take these factors into consideration.

A typical installation for an ac-dc battery receiver may be found in the General Television Model 23A6, shown on page 16-6 and in Fig. 3, where two selenium rectifiers are used to provide filament voltage and the B+ supply.

Selenium rectifiers are now to be found in voltage doubling, tripling, and quadrupling circuits, in half-wave, full-wave, and bridge

type rectifiers, and for recharging 2-volt wet batteries in portable receivers.

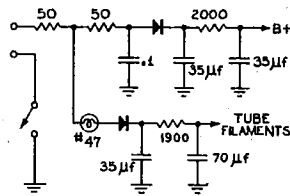

FIG. 3.—A typical installation of selenium rectifiers in an ac-dc receiver, one providing filament voltage, the other plate voltage.

**Installing Selenium Rectifiers**

When replacing a rectifier tube, it is usually necessary to add leads to the selenium rectifier lugs; it is recommended that a red lead be added to the positive (red) lug and a yellow or black lead to the negative (yellow) lug. The selenium rectifier may be installed in any convenient location. The rectifier plates will short out if they touch any other components. A cool location is preferred, near the r-f end of the set and away from dropping resistors. The eyelet in the center is insulated from the plates and may be used for mounting if the extension leads are not steady enough for that purpose. A protective cover over the selenium rectifier is advisable if it is not otherwise safeguarded.

The selenium rectifier, like any other rectifier, has two different values of resistance depending on whether it is conducting. When conducting there is a flow of current and its resistance is low. When not conducting there is no flow of current and its resistance must be high. This means that an ohmmeter may be used to determine the polarity of the selenium rectifier terminals in the event of doubt, for a small direct current can flow from the meter through the rectifier.

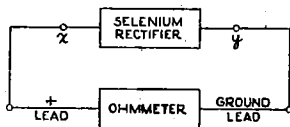

FIG. 4.—An ohmmeter can be used to determine the polarity of a selenium rectifier.

The meter is connected as shown in Fig. 4 and the resistance is read. The meter leads are reversed and another reading is taken. If the second reading is less than the first, terminal X should be marked positive (red), but if the second reading is greater than the first, terminal Y should be marked positive. The reason for this is that an ohmmeter is so constructed that an increased resistance reading indicates a decrease in current flow, thus indicating the correct direction of current flow through the

selenium rectifier. Actual measurements taken on a Federal Type 403D2624 gave readings of 8000 ohms and 500,000 ohms respectively.

**Rectifier Tube Replacements in A-C Receivers**

A serviceman desiring to take advantage of the selenium rectifier when replacing burned out rectifier tubes may utilize Table I and the accompanying diagrams. The tube being replaced is shown in Fig. 5. The first column in

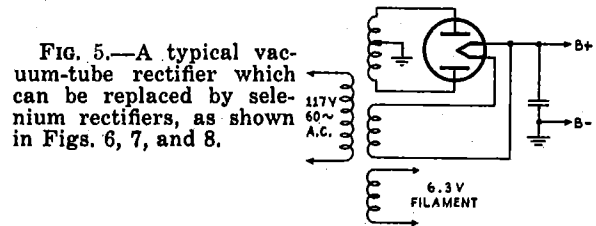

FIG. 5.—A typical vacuum-tube rectifier which can be replaced by selenium rectifiers, as shown in Figs. 6, 7, and 8.

Table I lists the type rectifier tube installed in the set. The second column indicates which wiring diagram (Figs. 6, 7, or 8) is to be followed. The third and fourth columns give the

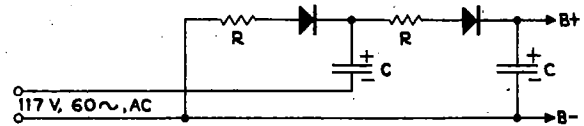

FIG. 6

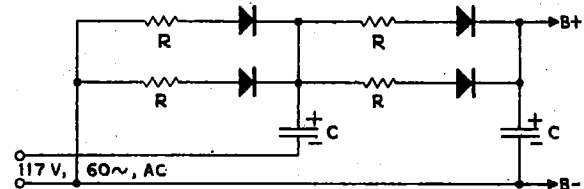

FIG. 7

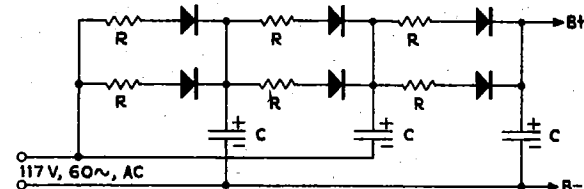

FIG. 8

The above schematics show connections for replacements of tube rectifiers by the selenium type. Values of capacitors and resistors are given in Table 1.

values of the circuit components. Receivers utilizing voltage multipliers (250 volts and 350 volts) are seen to use the same size components, but different wiring diagrams (Figs. 7 and 8 respectively).

**Rectifier Tube Replacements AC-DC Receivers**

When a selenium rectifier is used to replace a rectifier tube in an ac-dc receiver, it is neces-



TABLE I. RECTIFIER TUBE REPLACEMENT CHART USING FEDERAL TYPE 403D2625 SELENIUM RECTIFIER

Tube	Use Figure	C	R
			(1 watt)
5T4	7 for 250 volts 8 for 350 volts	50	5
5U4	7 for 250 volts 8 for 350 volts	50	5
5V4	7 for 250 volts 8 for 350 volts	50	5
5W4	6	50	10
5X4	7 for 250 volts 8 for 350 volts	50	5
5Y3	6	50	10
5Y4	7 for 250 volts 8 for 350 volts	50	5
5Z3	7 for 250 volts 8 for 350 volts	50	5
5Z4	6	50	10
6X5	6	50	10
6Y5	6	50	10
6X5	6	50	10
7Y4	6	50	10
12Z5	6	50	10
25Z5	6	20	0
35Z6	6	20	0
50Y6	6	20	0
50Z7	6	20	0
80	6	50	10

sary to supply a resistor to take the place of the tube filament, thus maintaining filament continuity and providing a potential for the pilot light. Fig. 9 shows the tube to be replaced.

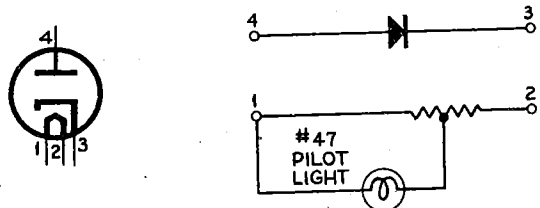

FIG. 9, left, FIG. 10, right.—The numbered receptacle terminals of a vacuum-tube rectifier socket are shown in Fig. 9 and in Fig. 10 are the selenium rectifier and resistor connected to these terminals.

Figure 10 shows that the selenium rectifier is connected to the receptacle terminals formerly used for plate and cathode, while a resistor is connected to those terminals that were used for the heaters. The pilot light is tapped across from terminal 1, using 10 to 25 ohms thereof. The actual tap point depends on the current used in the filament string.

The size of the resistor placed across the former heater terminals depends upon the rectifier tube being replaced. In Table II values are listed which have been compiled by the Federal Telephone and Radio Corporation.

TABLE II. RECTIFIER TUBE REPLACEMENT CHART USING TYPE 403D2625 FEDERAL SELENIUM RECTIFIER

Tube	Resistor	Watts
25Z5	85	15
25Z6	85	15
35W4	230	10
35Y4	230	10
35Z3	230	10
35Z4	230	10
35Z5	230	10
45Z5	300	10
50Y6	330	15
50Z7	330	15

The rating of the resistor connected in place of the heater may also be calculated. The filament voltage for each of the tubes is added together (not including the rectifier tube) and the sum is subtracted from the rated line voltage. The difference must be dropped across our resistor; since the filament current is given in the tube manual (each tube usually draws the same current, if not, the effective value of filament current must also be calculated), the resistance is calculated by Ohm's law:  $R = E/I$ . The resistor should be rated at least twice the number of watts given by the product of E and I.

Several alternative connections for the pilot light shown in Fig. 10 are suggested by Federal: (1) A 110-volt bulb may be placed across the line, Fig. 11, thus providing excellent illumination and isolation from the rest of the circuit. However, one connection must be to the dead

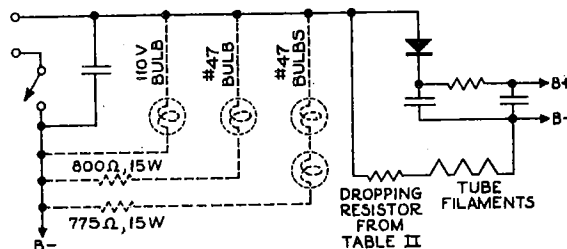

FIG. 11.—Alternate connections for one or more pilot lights are possible; see also Fig. 10.

side of the on-off switch or the light will burn continuously. (2) A number 47 pilot light in series with an 800-ohm 15-watt resistor across the line, Fig. 11. (3) Two number 47 pilot lights in series with a 775-ohm 15-watt resistor, Fig. 11. (4) The original method of

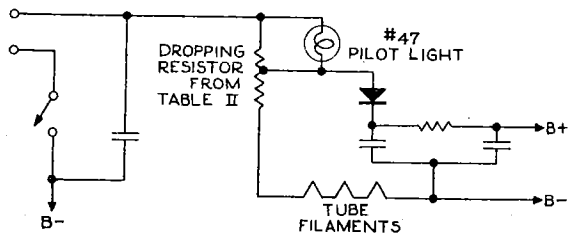

FIG. 12.—The complete schematic of a selenium rectifier and pilot light; see also Fig. 10.

Fig. 10 expanded into a full circuit diagram, Fig. 12.

#### Rectifier Tube Replacements AC-DC Battery Receivers

The replacement of a rectifier tube with a

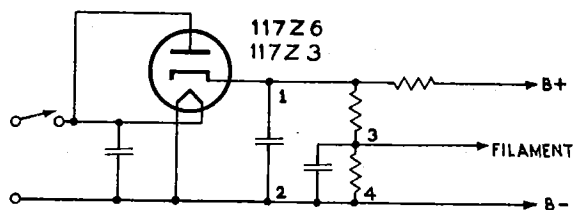

FIG. 13.—A typical rectifier circuit of an ac-dc receiver in which the internal tube resistance must be considered when replacing the tube with a selenium rectifier.

selenium rectifier in this type of receiver is complicated by the importance of the internal tube resistance. A typical circuit, such as shown in Fig. 13, requires two d-c voltage measurements: B+ (point 1 to 2) and filament voltage (point 3 to 4). The tube is now replaced with a Federal 100-ma selenium rectifier and a 27-ohm 1-watt resistor, as shown in Fig. 14. The positive lead (red) is connected to the cathode lug on the tube socket; the negative lead (yellow) is connected to the 27-ohm resistor, which in turn is connected to the plate lug of the tube socket.

The same two d-c voltage measurements are made, and if they are not within 10% of the

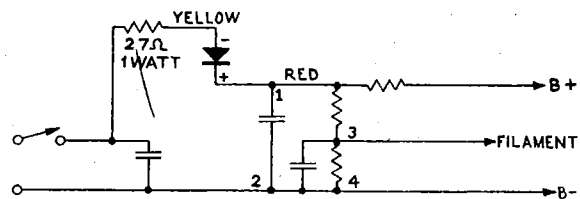

FIG. 14.—How a selenium rectifier is connected when replacing a vacuum-tube rectifier in an ac-dc circuit.

previous values, the 27-ohm resistor must be changed until they are within this limit. The final resistor value can be used in similar receivers without the need for voltage measurements. When determining this resistor value, time will be saved if it is placed in the circuit by means of clip leads until the final value is determined.

# PRE-EMPHASIS AND DE-EMPHASIS

In the audio systems of transmitters the level of the higher audio frequencies is relatively low as compared to the rest of the audio-frequency spectrum. Because of this inherently small amplitude, noise interference will be more evident at the high audio frequencies than at the lower. In other words, the signal-to-noise ratio at the high audio frequencies is lower than that at the low audio frequencies. In systems where the maximum amount of audio frequencies are put to use this effect is definitely undesired. Since in f-m broadcast transmitters the audio-frequency range is as high as 15,000 cycles, a system wherein the amplitudes of these high frequencies are accentuated is necessary for the faithful reproduction of the higher range of audio frequencies. This is exactly what is done in all of the broadcast f-m transmitters as a regulation of the FCC.

In the audio system of the transmitter, special circuits called *pre-emphasis* (or accentuation) networks are included to boost the amplitude of the high audio frequencies. The circuits involved may differ somewhat from each other but in most cases they are very simple. The pre-emphasis networks must have a special characteristic in which the gain increases with audio frequency.

The pre-emphasis characteristic curve as set down by the FCC is shown in Fig. 1. The solid

curve is that which is supposed to represent ideally the pre-emphasis characteristic of the pre-emphasis network used in f-m broadcast transmitters. The stipulation is that the gain for audio frequencies from 50 to 500 cycles is to be constant and that from 500 to 15,000 cycles the gain should increase with frequency. The increase is such that at 1000 cycles the gain rises almost 1 db, at 5000 cycles the gain rises approximately 8 db, at 10,000 cycles the gain rises 13.5 db, and at 15,000 cycles the gain rises about 17 db. See the solid curve of Fig. 1. This curve shows that although the noise characteristic increases at the high audio frequencies, the gain at the high audio frequencies also increases in order to maintain a high signal-to-noise ratio.

The dashed curve in the same figure shows the limitations of the audio-frequency response that is allowable for f-m transmitter design. In other words, if the frequency response of the audio system of f-m broadcasting transmitters falls within the two curves of Fig. 1, then it will be acceptable by the FCC. It is preferable, however, that the audio system have a response characteristic resembling the solid curve as much as possible.

Now when an f-m signal is transmitted, it bears this pre-emphasis characteristic of the audio frequencies somewhere between the limits of the curves of Fig. 1. Some may think that since the high audio frequencies are increased to such an extent there may be the possibility of overmodulation. However, since the high audio-frequency components of the actual audio signal, before it enters the pre-emphasis network, have a much smaller amplitude than the low audio frequencies, there is very little chance of really overmodulating the f-m transmitter to a point where it will be considered serious. It should be remembered that we are dealing with f-m and that 100-per cent modulation is equivalent to a peak deviation frequency of the carrier equal to 75 kc. Thus by overmodulating we mean that the amplitude of the high audio frequency may make the final peak deviation of the carrier greater than 75 kc.

The primary reason for this pre-emphasis network is to make sure that the high-frequency

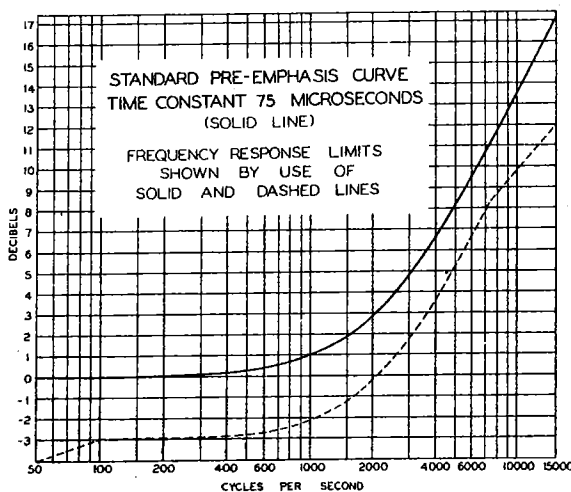

FIG. 1.—Pre-emphasis characteristic curve established by the FCC.

components of the transmitted intelligence are not blocked out by the inherent noise characteristics at these frequencies. Now when this f-m signal is picked up by the receiver it will have this same pre-emphasis characteristic in the intelligence it bears.

To be certain that the audio frequencies are all, more or less, brought down to the same level before audio amplification in the f-m receiver, a *de-emphasis* network is usually inserted in the receiver between the f-m detector and audio amplifier. This de-emphasis network has a frequency characteristic just the opposite of the pre-emphasis network; that is, its high-frequency response is *decreasing* in the same way the pre-emphasis network was increasing. In this manner the high frequencies will be brought down to their proper relationship to the level of the low frequencies for a more constant voltage input to the audio system of the receiver for the complete range of audio frequencies. In other words, the characteristic curve of the de-emphasis network should be as nearly as possible a mirror image of the pre-emphasis characteristic curve.

Now in order to make sure that the de-emphasis network in the receiver is the inverse to that in the transmitter the FCC has set a standard of a 75 microsecond *time constant* for the pre-emphasis network in the transmitter. (It formerly was 100 microseconds.) Consequently the de-emphasis network in the receiver must also have a time constant equal to 75 microseconds in order to have the de-emphasis curve be the mirror image of the pre-emphasis curve.

The reason a time constant of 75 microseconds is established by the FCC as good engineering practice is that the most satisfactory frequency-response characteristic will be obtained by that time constant. In order to understand what determines the time constant let us examine some typical pre-emphasis and de-emphasis networks.

In Fig. 2, two pre-emphasis networks are illustrated. In either case as the audio frequency increases the proportion of the input voltage impressed across the grid of the tubes also increases. For instance, in Fig. 2(A) the total impedance to the audio voltage is given by the series combination of  $R$  and  $L$ . Now as the frequency increases the inductive reactance also

increases. This means that a relatively greater voltage drop will exist across the inductance at the higher frequencies than at the lower frequencies. Consequently, the relative voltage

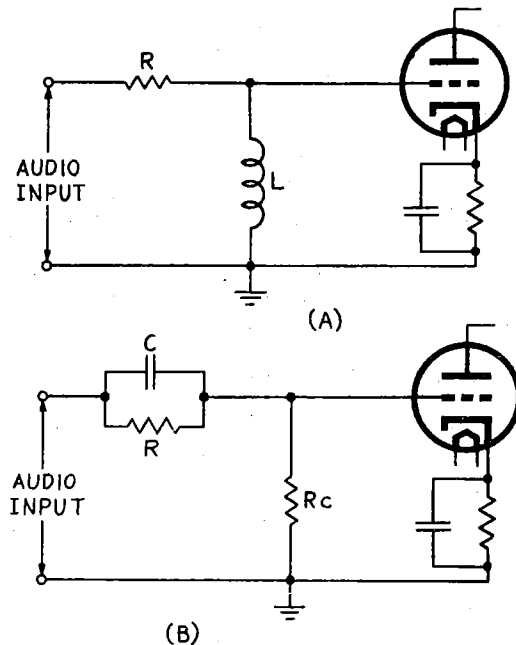

FIG. 2.—Two typical pre-emphasis networks.

across the grid of the tube increases with increase in frequency.

In Fig. 2(B) the pre-emphasis network, consisting of  $C$  and  $R$  in parallel and  $R_c$  has the same effect. The impedance offered to the audio voltage is effectively that of the parallel combination of  $R$  and  $C$  only because the resistance of the grid resistor  $R_c$  is small in comparison to either  $R$  or the reactance of  $C$  at the audio frequencies. Therefore, as the audio frequency is increased the capacitive reactance of  $C$  decreases, allowing a ready path for the higher frequency currents as compared to the resistance of  $R$ . This means that the signal current increases with increase in audio frequency, which results in a greater voltage drop across the grid resistor  $R_c$ .

A typical de-emphasis network as used in most f-m receivers is shown in Fig. 3; it functions in a reverse manner to the pre-emphasis network. The effective impedance offered to the audio voltage is the series combination of  $C$

and R. As the frequency of the audio signal increases, the reactance of the capacitor C decreases. Thus, as the frequency increases, the reactive voltage drop decreases. Consequently, the audio voltage across the grid of the tube decreases with increase in frequency and the reverse effect of the pre-emphasis circuit is seen.

In order to make sure that the pre-emphasis and de-emphasis effects follow each other in respect to the increasing and decreasing amplitude of the high audio frequencies, the time constants, as mentioned, should be equal to each other. It is a relatively simple procedure to determine the time constant for the networks shown in Figs. 2 and 3. In the resistance-

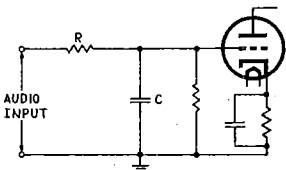

FIG. 3.—A typical de-emphasis network used in f-m receivers.

capacitance networks the value of the time constant is given by  $R \times C$ , where R is in ohms and C in microfarads and the value of the time constant will be in microseconds. Thus for a resistance of 30,000 ohms and a capacitance of .0025 mf the time constant will be  $30,000 \times .0025$  or 75 microseconds. In the resistance-inductance network the time constant in microseconds is given by  $L/R$ , where L is in henries and R in megohms. Thus for an inductance equal to 7.5 henries and a resistance equal to .1 megohm (100,000 ohms) the time constant will be  $\frac{7.5}{.1}$  or 75 microseconds.

#### Montgomery Ward Model 74WG-2505A

In the Montgomery Ward f-m Models 74WG-2505A and 74WG-2705A a typical de-emphasis network is readily evident from the "clarified schematic," page 16-23 of Rider's Vol. XVI. That part of the circuit of interest is illustrated

in Fig. 4. Between the audio output circuit from the 6AL5 discriminator and the first audio tube (6AT6), a simple RC network is placed, similar to that of Fig. 3 to perform the functioning of de-emphasis. These components are

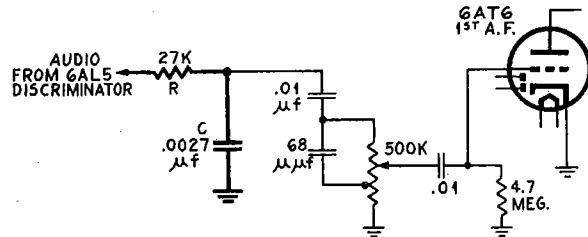

FIG. 4.—The RC de-emphasis circuit of Montgomery Ward Model 74 WG-2505A.

shown by the heavy lines indicating the resistance and capacitance circuit, labelled R and C respectively in Fig. 4.

Basically, the f-m signal appearing at the input to the f-m discriminator has the pre-emphasis characteristics of the f-m transmitter. Consequently, the audio output from the discriminator will have its high frequencies accentuated in comparison to its low frequencies. For proper audio amplification the audio input to the audio amplifier must be flat for all audio frequencies. The RC de-emphasis network accomplishes this flattening out of the audio frequencies. Therefore, the audio input to the 6AT6 first audio amplifier will have approximately the same characteristics as the audio input to the microphone at the f-m transmitting studio.

The time constant network for this de-emphasis network is equal to R multiplied by C. Since R is equal to 27,000 ohms and C equal to .0027 mf, the time constant will be  $R \times C$ , or  $27,000 \times .0027$ , or 73 microseconds. Since the tolerance of the resistors and capacitors is usually 10 per cent, this calculated value of time constant is considered fairly good design in conforming with the regulated 75-microsecond time constant for the f-m transmitters pre-emphasis network.

# SPECIAL AVC CIRCUITS

The use of avc in superheterodyne receivers is well-nigh universal today. Avc has been employed for well over a decade since its first commercial appearance. It is natural that in this time many modifications and variations of the basic circuit have appeared. Some of these have been designed for special purposes, and so are not widely encountered. Others, which appeared to be promising as improvements, were shown by experience not to live up to expectations, and as a result have fallen into disuse. Then again, certain variations have proven very valuable, and have stood the test of time. One of these is delayed avc, or dave.

The word delayed, in the term delayed avc, is well chosen, for it accurately expresses the essential feature of this particular type of avc. In a receiver having dave the operation of the avc feature is delayed until the input signal reaches a certain level. That is, for very weak signals the set behaves as though it had no avc, but for stronger signals the avc is operative. The desirability of dave lies in the fact that a receiver without avc has an inherently higher sensitivity than a set having avc, all other factors being equal. In other words, if two sets were designed along the same lines, except that one was equipped with simple avc and the other was not, the one without avc would be more suitable for receiving very weak signals. On the other hand, the set with avc would show up to great advantage whenever the received signal exceeded a small value. The reason for this is that in a simple avc system the action begins as soon as a signal is received, and thus for even a very weak signal there is some reduction in receiver sensitivity because of the avc bias produced by the rectification of this weak signal.

The usefulness of dave stems from this condition, for it offers the advantages of no avc for very weak signals, while it retains the advantages of avc at higher input levels. This is accomplished by the use of a bias in the avc system, which prevents the operation of the avc action when very weak signals are received. However, stronger signals can overcome the effect of the bias, and thus produce normal avc action. As a result, the use of dave gives a re-

ceiver an effectively higher sensitivity than a simple, unmodified avc system.

Because of the benefits offered by dave it is used in many of the more expensive receivers. (The extra parts naturally required by a system more complicated than simple, unadorned avc add to its cost. In many cases, particularly in broadcast receivers not intended for long-range reception, the additional complication of dave is a disadvantage not sufficiently compensated for by its operational advantages, and so it is not used.) Two examples of the use of dave in recently designed receivers are found in the Magnavox Model CR-183 found on pages 15-13, 14 of Rider's Vol. XV and the Montgomery Ward Airline 74BR-1812A found on page 16-18 of Rider's Vol. XVI. The dave systems used in these sets are described below.

## Magnavox Model CR-183

In the Magnavox Model CR-183 an additional resistance-capacitance-coupled i-f amplifier stage and a separate diode are used to obtain dave. The avc amplifier, V5 (see Fig. 1), is a 6SG7, a pentode having a semi-remote cutoff characteristic. When no signal is received, the cathode of this tube is 11.5 volts positive with respect to ground. At the same time the grid potential is approximately that at the junction of resistors 220-2 and 212-1, since no appreciable current flows through resistors 205-1 or 201-5 under this condition; this potential is about 6 volts positive with respect to ground. Thus, when no signal is received, the grid of V5 is biased approximately 5.5 volts negative with respect to the cathode. At the same time, the cathode (pin 8) of the avc section of the duo-diode, V4, is also about 6 volts positive with respect to ground (since the cathode is connected through resistor 205-1 to the same junction point of resistors 220-2 and 212-1), and the avc diode plate (pin 5) is approximately at ground potential.

Because the cathode of the avc diode is thus about 6 volts positive with respect to its plate, no rectification will be produced by this tube unless the peak voltage of the i-f signal applied through capacitor 117-2 to the diode plate is sufficient to overcome the effect of the voltage

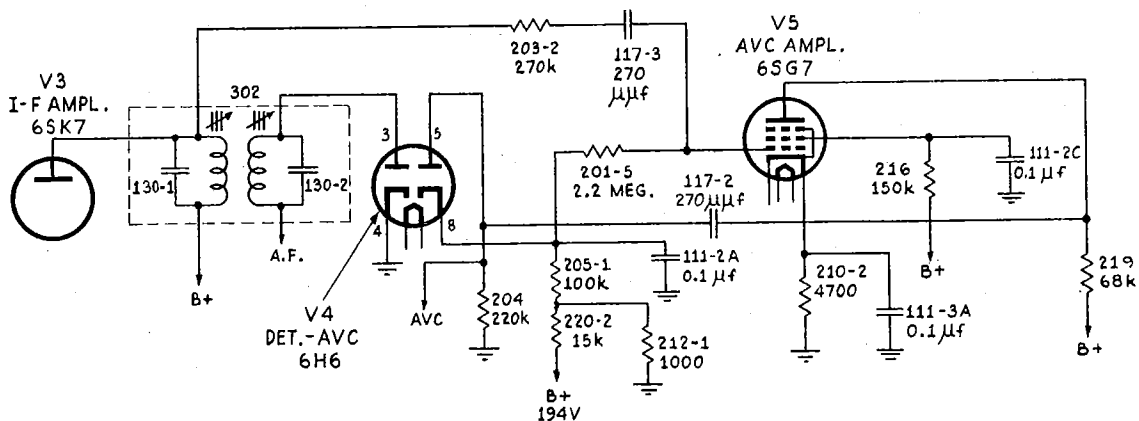

FIG. 1.—Detector and avc system of Magnavox Model CR-183.

on the cathode. The 6-volt bias applied to the cathode (pin 8) is thus known as the delay voltage, since it delays avc operation until a signal sufficiently strong to overcome it is received.

When a sufficiently large signal is received to produce current flow through the avc diode, the end of resistor 204 connected to the plate (pin 5) goes negative with respect to the other end (ground), thus providing a source of avc voltage. At the same time the end of resistor 205-1 connected to the cathode (pin 8) of the avc diode goes positive with respect to its other end, raising the voltage on the control grid of V5 above 6 volts and thus decreasing the bias on this grid. This produces a reverse avc action on V5 because of its semi-remote cutoff characteristic. As a result, large signals fed through V5 are amplified more than small signals, and this has the effect of increasing changes in signal level before the signals are rectified to provide avc voltage. For example, if the signal input to V5 is doubled, the output is more than doubled; and if the input is halved, the output falls to less than half. This effect increases the changes in avc voltage produced by changes in signal input to the receiver. As a result the avc system is more sensitive and has a greater leveling effect on variations in the input signals than if V5 with its reverse avc were not used.

Montgomery Ward Airline 74BR-1812A

A 6AL5 duo-diode tube employed as a ratio detector is used in the Montgomery Ward Airline 74BR-1812A as an f-m detector. This con-

venient source of avc supplies a control voltage through R32 to the avc-controlled grid of the first i-f amplifier, as shown in Fig. 2. In order to obtain maximum sensitivity for very weak signals, d<sub>avc</sub> is employed. The delay voltage is obtained from B+ through resistor R8 in conjunction with one of the diode sections of the 6AT6.

Resistor R8 and the diode form a voltage divider, with the diode having a very low resistance, when there is no avc voltage, because the

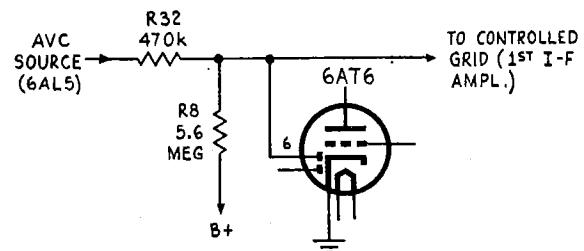

FIG. 2.—Avc delay voltage network used in Montgomery Ward Airline 74BR-1812A.

positive voltage applied through R8 causes it to conduct. As a result the avc-controlled grid is virtually at ground potential. When a signal is received, a negative avc voltage is produced. This also is impressed across a voltage divider, of which the same diode is a part. The other arm of the divider is resistor R32. If the signal is very weak, the avc voltage is very small, and is not sufficient to prevent the positive voltage applied through R8 from maintaining conduction through the diode. The effective resistance

of the diode therefore remains low, and the *avc* is virtually shorted to ground.

When a stronger signal is received, however, a larger *avc* voltage is produced. Since this is applied to the diode through a much smaller resistor ( $R_{32}$ —470,000 ohms) than that ( $R_8$ —5.6 megohms) through which  $B+$  is applied, it has a relatively greater effect. Hence, as the signal strength increases, the diode conduction decreases, since the positive voltage from  $B+$  is partially or, for large signals, entirely can-

celled by the negative *avc* voltage. This reduction, or complete cessation (when the positive voltage effect is entirely cancelled), of diode conduction is equivalent to an increase in the effective resistance of the diode. When the diode resistance increases, the *avc* is no longer shorted to ground. Thus by taking advantage of the variable resistance characteristic of a diode, it is possible effectively to eliminate the *avc* for very weak signals, and to bring the *avc* into play for stronger signals.



# TUNING INDICATORS FOR F-M RECEIVERS

It is quite feasible to tune an f-m receiver by ear, just as it is in the case of an a-m receiver. At the same time, a visual tuning indicator is desirable in an a-m receiver so that optimum results may be obtained. In an f-m receiver this need is even more pronounced, because it is less easy to tune accurately by ear for f-m reception than for a-m reception. The greater difficulty in the f-m case is due to two of the inherent differences between f-m and a-m receivers. One of these is the broad flat-topped i-f pass-band used in f.m.; the other is the use of balanced detector circuits (such as the Foster-Seeley discriminator and the ratio detector), which are employed almost universally.

The i-f pass-band of an a-m receiver is relatively peaked, as compared with that of an f-m receiver. Because of this, there is a very noticeable peak in the audio output of an a-m receiver when the receiver is tuned so that the actual i-f center frequency coincides with the proper operating center frequency. This peak can be, and frequently is, used as an audible indication of proper tuning. In an f-m receiver this effect is very slight, if it exists at all. This is particularly true of receivers employing one or more limiters.

The use of a balanced detector circuit in an f-m receiver makes it less susceptible to a-m interference (including noise) if the receiver is properly tuned. The reason for this is that the balanced circuit tends to balance out signals (such as noise) which affect both sides of the balanced system equally. This equality of effect on both sides of the balanced detector is fully true only when the actual i-f center frequency is the same as that to which the detector is tuned. Therefore, any mistuning will increase the noise and other interference present in the output. In addition, mistuning engenders distortion, particularly at high modulation levels.

## Types of Tuning Indicators

Having seen the desirability of a tuning indicator in an f-m receiver, we can now consider the types of indicator that may be used. The simplest indicating system is that used frequently in a-m receivers, namely, a tuning in-

dicator tube whose shadow angle is controlled by the avc voltage. Some f-m receivers employing the Armstrong limiter-discriminator combination do not have avc, but the first limiter grid voltage varies in accordance with the strength of the received signal reaching it. This grid voltage may therefore be used to control the tuning-indicator tube. When a ratio detector is used, an avc voltage can be obtained from this stage.

Although the great simplicity of this system is an advantage not to be overlooked, it has a definite disadvantage that causes many radio designers not to use it. This disadvantage lies in the fact that the avc (or first limiter grid) voltage may not be a maximum at exactly the same frequency as that which is optimum for operation of the detector. This condition should not be found in a set which has just been aligned; but when some time has passed since a set was last aligned, it is natural that drifts will have occurred. Consequently, it may not be possible to obtain exactly this tuning by means of the avc voltage-controlled tuning-indicator tube, because the avc voltage depends upon the over-all i-f amplifier tuning, and not upon the tuning of the detector.

## The Meter Indicator

Another indicator is a meter, preferably of the center-zero type. The Foster-Seeley discriminator and certain forms of the ratio detector have a d-c component in their audio outputs. This voltage is zero when the actual center frequency of the i-f signal is at the frequency on which the detector is aligned. If the frequency is off, but still within the operating range of the detector, this d-c component will have a polarity depending upon whether the frequency is high or low and an amplitude depending upon the extent to which the frequency is off. If a meter is connected to read this voltage, it can be used as a tuning indicator, with correct tuning shown by a zero reading. This method of indication has the obvious advantage over the avc voltage-controlled tuning indicator tube of showing optimum tuning directly and definitely. However, it, too, has its disadvan-

tages, perhaps even greater than those of the method described first.

To begin with, meters are expensive, particularly the more sensitive types such as are required for this service. This would not be a serious objection in a laboratory or in some types of test instruments; but in a typical home receiver the cost would be out of proportion to the utility. Another objection is that many people would find the cold austerity of a meter out of place in what is, after all, a decorative piece of furniture as well as a useful electronic device, and might also object to the space occupied on the panel by the meter. Again, most home receiver owners who have had any experience with tuning indicators are used to the tuning-indicator tube, and would probably prefer to retain a type to which they are accustomed.

#### Operational Difficulties

Aside from these non-technical drawbacks, there is an operational difficulty of some importance. This lies in the fact that the usual type of d-c meter has a linear scale. It is therefore just as sensitive to the d-c voltage produced by a badly detuned signal as to that associated with a slightly detuned signal. On badly detuned signals, the meter indication is of little importance, for these can be spotted easily by ear. However, when the set is almost exactly tuned, the slightest error should be clearly defined by the swing of the meter needle. To overcome this drawback, a special type of center-zero d-c meter may be used. The permanent magnets in this type of meter are so shaped that the meter is much more sensitive at the center of the scale than at either end, with a gradual change of sensitivity throughout the range.

As an example of this type of meter, suppose one were used which would give a *half-scale* deflection either side of zero (depending on polarity) for a 1-volt signal, while a 10-volt signal would be required for *full scale*. On such a meter a 0.1-volt signal could be read as easily as on a 2-0-2-volt linear-scale meter. This same meter would be unharmed by a 10-volt signal, which would probably burn out a 2-0-2-volt meter. At the same time, a 10-0-10-volt linear-scale meter, which would be unharmed by a 10-volt signal, would give a barely readable deflection for a 0.1-volt signal.

A final difficulty in tuning with a meter,

though not one of great importance, is the possible uncertainty attendant upon its use. The reason for this is that when no signal at all is received, the d-c signal from the detector to the meter is zero, just as when a station is properly tuned in. Thus, in a quiet location there may sometimes be reason to wonder whether a tuning-meter zero indication signifies an unmodulated carrier properly tuned in or no signal at all.

To summarize the above, it may be said that the tuning indicator tube controlled by AVC voltage has these advantages over the tuning meter:

1. Economy, which benefits all concerned, from the manufacturer to the final set owner.
2. Familiarity, which makes the tube easier for the average set owner to use.
3. Certainty, which enables the set owner to distinguish between an unmodulated carrier and absence of signal under quiet reception conditions.

On the other hand, the meter is superior to the AVC voltage-controlled tuning indicator tube on the following counts:

1. Sensitivity, which causes the meter needle to deflect more than the tube shadow in the tuning region immediately around optimum tuning.
2. Accuracy, which stems from its control by the detector, so that a true indication is obtained, regardless of alignment drifts.

From the foregoing comparisons, we may attempt to deduce the desirable characteristics of a tuning indicator for a home f-m receiver. The following list is such an attempt:

1. Economy
  2. Familiarity
  3. Non-linearity, which gives sensitivity where *it* is needed, and overload protection where *that* is required
  4. Certainty
  5. Accuracy
- A sixth characteristic may be added:
6. Flexibility, which enables the user of an am-fm receiver to use the same indicator in the same way for tuning to either type of transmission, a-m or f-m.

The six requirements just outlined can be met with a good measure of success by the use of a conventional tuning indicator tube in con-

junction with a special circuit which permits the simultaneous application to the tube control electrodes of both avc (or first limiter grid) and detector tuning indication voltages. (The detector tuning indication voltage is the d-c component that appears in the audio output; this voltage was discussed in connection with the subject of meter tuning indicators.)

In an arrangement such as this, there may be some doubt as to how well the first requirement is met, but the extra components and labor involved should be considerably cheaper than a meter. The second requirement is obviously met by the use of a conventional tuning indicator tube, while the third can be satisfied by the use of a remote cutoff tube in the indicating system. The fourth and fifth are obtained by the use of the avc and detector tuning indication voltages, respectively. The sixth can be taken care of by providing a switch section in the am-fm switch which will permit application of the a-m avc voltage to the tuning indicator tube in conventional fashion when an a-m program is being received.

#### Stromberg-Carlson 1135-A

An f-m tuning indication system is used in the Stromberg-Carlson Model 1135-A appearing on pages 16-11, 12 of Rider's Vol. XVI, which exhibits the characteristics discussed in the preceding few paragraphs. It may be noted in passing that the indicator tube used in this system is also used for a-m tuning in the conventional fashion. Switch Section 8R (see Fig. 1) makes the necessary connection when the switch is in the a-m position.

The 6SQ7 and 6SL7GT tubes shown in Fig. 1 function as transfer devices to apply both the first limiter grid and detector tuning indication voltages to the indicator tube in the manner

necessary for its operation, and without causing interaction between the first limiter and the discriminator. The 6SQ7 is simply a buffer, which prevents the other voltages in the system from affecting the first limiter grid voltage and possibly interfering with the action of the limiter.

When no signal is received, the grid of the 6SQ7 is virtually at ground potential, because there is no rectification at the limiter grid. When a signal is tuned in, a negative voltage from the limiter grid is applied to the 6SQ7 grid. The amplitude of this voltage varies just as an avc voltage does, in accordance with the strength of the received signal and with the tuning. When the i-f center frequency coincides with the i-f amplifier peak, this negative voltage has its peak value. The application of this negative voltage to the 6SQ7 decreases its plate current, thereby raising its plate voltage.

Since the plate of the 6U5G is tied to the 6SQ7 through R38, its voltage also rises (the effect of the 6SL7GT will be described later). This is exactly what would happen if a negative voltage were applied to the 6U5G grid. Therefore, the application of the voltage from the first limiter grid has the same effect as applying this voltage to the grid of the 6U5G. If it were not for the 6SL7GT, this indication system would operate in the same fashion as the simple avc voltage-controlled tuning indicator tube described above. That is, the "eye" would be open when no signal is received, and would reach maximum closure when the i-f center frequency corresponding to a received signal, is at the i-f peak.

Before considering the functions of the 6SL7GT, we should recall two facts important in the operation of this indication system. For one, we must remember that the tuning indica-

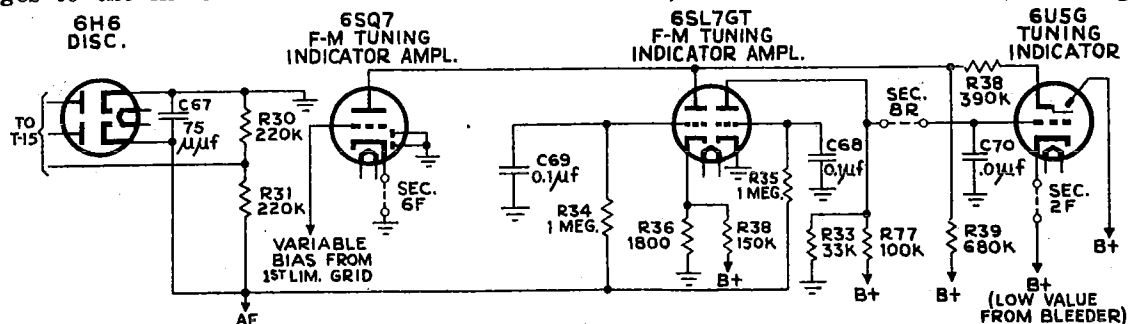

FIG. 1.—The tuning indicator tube, 6U5G, is used for both a.m. and f.m. in the Stromberg-Carlson Model 1135-A. The 6SQ7 and 6SL7GT tubes act as transfer devices to apply the first limiter grid and detector tuning indication voltages to the 6U5G indicator.

tion voltage derived from the discriminator may be either positive or negative when the received signal is mistuned. The other fact is that to indicate mistuning, we must *not* apply a negative signal to the 6U5G grid. The reason for this is that a negative signal to this grid causes the "eye" to close, but we desire that maximum closure be obtained when the set is tuned so that the actual i-f center frequency is the same as the frequency on which the discriminator is centered. Under this condition, the detector tuning indication voltage is zero, not negative.

Now, since it is desired that the closure of the "eye" be less than maximum when the set is mistuned, it is necessary that the *effect* of the detector tuning indication voltage on the "eye" be that of a positive voltage at the grid of the "eye," *regardless* of the true polarity of the indication voltage. This effect can be obtained by applying a positive signal to the grid (which causes the plate of the 6U5G to go negative—that is, become less positive—because of the increased IR drop across R38 and R39) or a negative signal to the plate.

#### Transfer of Tuning Indication Voltage

It is the purpose of the 6SL7GT to transfer the detector tuning indication voltage to the 6U5G in such a way, that, when the set is mistuned, it has the effect of a positive signal at the grid of the 6U5G. This is accomplished as follows: the left triode of the 6SL7GT is biased approximately to cutoff, so that a negative tuning indication voltage will have no effect on it. However, if a positive signal is applied to the grid, plate current will flow. Since this plate current flows through R39, the IR drop across that resistor must increase, thereby lowering the plate voltage of the triode section of the 6U5G. As was pointed out above, this has the same effect as a positive voltage on the grid of the 6U5G; that is, it reduces the extent to which the "eye" closes. R34 and C69 constitute an audio filter, so that only the tuning indication voltage output of the discriminator affects the left triode.

The right triode operates with zero fixed bias. Now, if the tuning indication voltage is positive, grid current will flow in this section. When grid current flows, the effective grid-cathode resistance drops to a value very small

compared to one megohm. Since the grid-cathode resistance and R35 form a voltage divider, virtually all of the positive signal will appear across R35. Thus the grid-cathode voltage will remain almost unchanged, and so a positive signal has no significant effect on the right triode. In addition to the function just described, R35 acts with C68 to form an audio filter just as R34 and C69 do.

On the other hand, if the tuning indication voltage goes negative, no grid current will be drawn in the right triode. The grid-cathode resistance under this condition is very many megohms, so that R35 has a negligible voltage-dividing effect. Thus a negative signal will reduce the plate current, causing a decrease in the IR drop across R77. This raises the grid voltage of the 6U5G, decreasing the closure of the "eye."

The cathode of the 6U5G is connected to a point positive with respect to ground, since otherwise the grid of this tube would be positive with respect to the cathode. The cathode voltage is therefore chosen such that the grid has a negative bias when no signal is applied to the 6SL7GT.

#### Operation of Tuning Indication System

Briefly, then, the operation of this tuning indication system is as follows: When a signal is received by the radio, but is not tuned in correctly, a small negative voltage due to rectification appears at the grid of the first limiter. This voltage, acting through the 6SQ7, causes the "eye" to close slightly. At the same time, a positive or negative tuning indication voltage from the discriminator acts through one of the sections of the 6SL7GT, depending upon its polarity. Regardless of the polarity, however, its effect is in opposition to that of the limiter grid voltage, so that the closure of the "eye" is not very great. When the receiver is tuned somewhat better, the limiter grid voltage will increase, while the detector tuning indication voltage will decrease; the "eye" will therefore close further.

Finally, when the receiver is tuned correctly, the limiter grid voltage will be at, or very near, its maximum value. The detector tuning indication voltage will be zero, and therefore the "eye" will be at maximum closure. If the receiver is slightly detuned, the limiter grid volt-

**TUNING INDICATORS FOR F-M  
RECEIVERS**

27

age will be only slightly affected, if at all, because of the broad i-f band-width. However, the detector tuning indication voltage will

follow any tuning change, and thus the "eye" is very sensitive to tuning errors in the range where this sensitivity is needed.

# TELEVISION H-V POWER SUPPLIES

A television picture tube requires a source of high d-c voltage; the tube 10BP4 used in the G.E. Model 801 shown on pages 16-25, 26 of Rider's Vol. XVI requires 8000 volts. Normally, we obtain a high d-c voltage by applying 60-cycle a.c. to a step-up transformer, rectifying, and then filtering the output; above 4000 volts, however, a transformer is heavy, bulky, and expensive. The use of an r-f power supply is a recent development that not only simplifies transformer and filter design but provides more safety for servicemen.

The unusual feature of the G.E. Model 801 high-voltage power supply is that the rectifier plate voltage is obtained from the horizontal-deflection system during the retrace or flyback of the sweep, rather than from the a-c line. To analyze this operation, we must see how the horizontal output tube, an 807, and the damping tube, a 6AS7G, generate a pulse that excites the step-up transformer, *T9*, thus providing a high voltage which is rectified by the 8016, as shown in Fig. 1.

The 807 is a well-known beam tetrode, capable of handling heavy current; its main function is to supply the power current waveform to the horizontal-sweep coils so that a horizontal trace of proper length is applied to the viewing tube. The 6AS7G is a dual triode, hav-

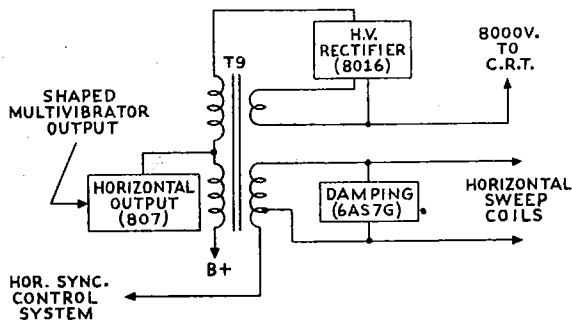

FIG. 1.—Block diagram of high-voltage rectifier and associated circuits in G. E. Model 801.

ing an amplification factor of only 2.1 and a plate resistance of 140 ohms when the two sections are connected in parallel. This tube damps the high-frequency oscillation set up

during the flyback period of the electron beam.

The usual high-voltage rectifier, such as an 878, requires considerable heater power and is not designed for r-f operation. The 8016 diode was developed for this purpose and requires only a quarter of a watt for the heater. Fig. 1 shows the heater voltage for the 8016; is obtained by a very small secondary winding on transformer *T9*.

The 10BP4 picture tube is scanned by a magnetic coil system, but only the horizontal sweep coils enter our study of the h-v power supply. For proper scanning, the current in the

FIG. 2.—Saw-tooth form of current in horizontal sweep coils.

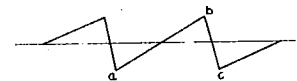

sweep coil must have a saw-tooth form, such as shown in Fig. 2, the forward trace across the screen occurring during period *a-b* and the retrace or flyback during the much shorter period *b-c*. The forward trace must be as linear as possible so that distortion is prevented.

## Circuit Functions

The sweep trace takes place when the output of the 807 tube is applied to the horizontal-sweep coils, and *T9* is so designed that a proper impedance match exists between the tube and coils. When the 807 stops conducting, the components to the right of *T9* (see Fig. 3) are excited into violent oscillation, and the oscillation is used to obtain the rapid flyback, *b-c* in Fig. 2. Any oscillation beyond the first half cycle is undesirable, as it will affect the linearity of trace *a-b* in Fig. 2, and the 6AS7G is used to damp it out. Very little of the magnetic energy is consumed by the flyback, and the collapsing field produces a positive voltage pulse on the primary of *T9*; this pulse is stepped up by the additional winding shown on the primary; it is then rectified by the 8016 and delivered to the viewing tube.

The detailed functioning of each component may now be examined, keeping the previous discussion in mind.

The input to the 807 is obtained from a multi-

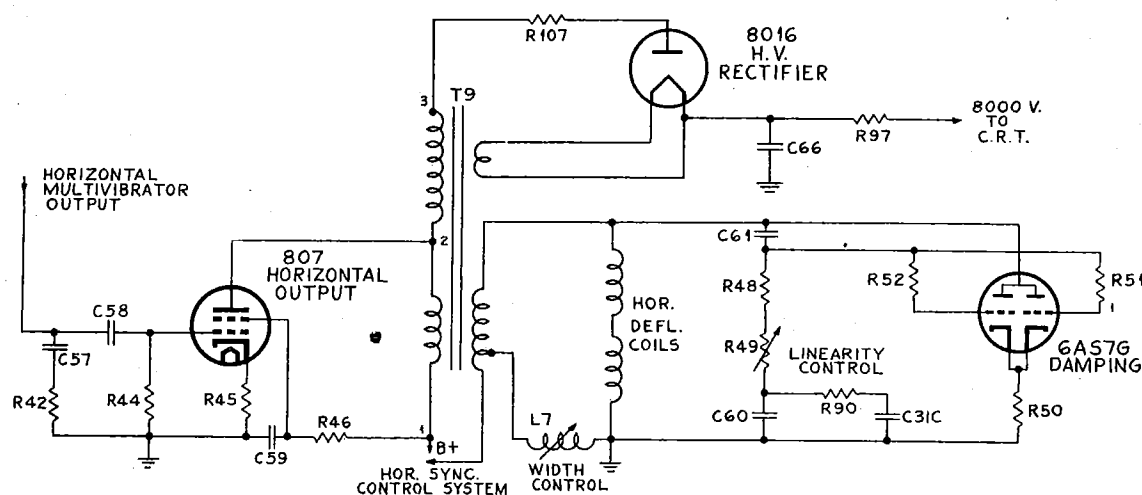

FIG. 3.—Circuit diagram of high-voltage supply of G. E. Model 801.

vibrator (6SN7GT), which is a two-tube oscillator that normally produces a rectangular output. However, the network composed of  $R42$ ,  $R44$ ,  $C57$ , and  $C58$  (see Fig. 3) is so designed that we obtain a saw-tooth waveform with a negative pulse, such as shown in Fig. 4. This is the input that is applied to the 807 grid.

The collapsing field in the horizontal-deflection coils produces a positive voltage pulse on the primary of  $T9$  and consequently on the 807 plate. The negative pulse on the 807 grid,  $a-b$  in Fig. 4, ensures that the 807 is cut off during the flyback period, in spite of the high plate voltage.

During the trace period ( $c-a$  in Fig. 4) when the 807 is conducting, the sawtooth grid voltage produces a sawtooth plate current. The effective plate load is the horizontal-deflection coils,  $T9$  being used only as an impedance transformer to match the coils to the tube. Since the plate load is inductive, if a sudden change in current takes place we obtain a high-voltage pulse, this sudden change taking place during  $a-b$  of Fig. 4. During  $c-a$  of Fig. 4 the energy supplied to the yoke builds up, and continues to do so until the negative pulse occurs.

At this instant, when the 807 is cut off, the components between  $T9$  and the 6AS7G are shocked into violent oscillation ( $L7$ , horizontal-deflection coils, part of  $T9$  and distributed capacitances). During the first half cycle, which is negative, the current in the horizontal-deflection coils has reached a maximum in the direction opposite to which it was flowing and

the flyback has consequently taken place. At the end of the first half cycle the voltage starts to go positive. The 6AS7G now conducts, since its plate is positive, and the oscillation is rapidly damped.

Transformer  $T9$  has four functions. Its main function is to transform the inductance of the horizontal-deflection coils to a value that meets the operating conditions of the 807. A small

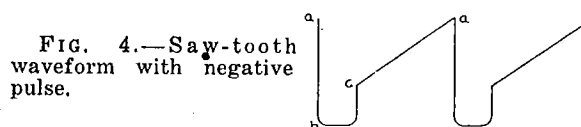

FIG. 4.—Saw-tooth waveform with negative pulse.

secondary tap supplies heater voltage for the 8016. It also takes the inductive "kick" voltage from the collapsing magnetic field during flyback and places it on the primary. Finally, this voltage pulse on the primary is raised by autotransformer action to 8000 volts and applied to the 8016 plate. (In an autotransformer the input is applied to a portion of the winding, terminals 1-2 of Fig. 3, and the output is taken across the entire winding, terminals 1-3. It has these advantages over the ordinary two-circuit transformer: better voltage regulation, greater efficiency, and smaller size; it does have disadvantages, such as lack of d-c separation, which prevent its more universal use.)

The 8016 rectifies this high-voltage pulse.

Due to the high frequency at which this takes place, a 500-mmf capacitor, *C66*, is sufficient for filtering, and as its small value means small energy storage, there is consequent reduction of

danger when servicing the high-voltage supply.

The 8000-volt output is now applied to the viewing tube through the filter section *C66* and *R97*.



# BATTERY CHARGING CIRCUITS

A battery, consisting of two or more cells, supplies direct current by means of chemical action, which is the result of the changing of chemical compounds into another form. While the life of a battery is inherently limited, proper use will prolong it considerably. In the *storage* battery, the chemical process can be reversed by putting electric energy into the battery, thus converting the chemicals to their original condition. The familiar dry-cell must be discarded when fully discharged, for reversing the current flow will not return the chemicals to their original condition.

The dry-cell battery generally employed in portable receivers consists, basically, of a negative zinc plate and a positive carbon rod immersed in a pasty mixture containing ammonium chloride and other chemicals. The entire unit is sealed in a container to prevent escape of gases or the entrance of external substances. When the battery delivers current, ammonium chloride combines with the zinc to form zinc chloride and free hydrogen ions. These free hydrogen bubbles travel toward the carbon rod and tend to collect around it, decreasing its effective area and thereby increasing the internal resistance of the cell. This accumulation of hydrogen on the carbon rod is termed "polarization" and the greater the polarization the less current the cell can supply. If the cell is permitted to rest for a while, one of the chemicals in the pasty mixture (manganese dioxide) will absorb the hydrogen, and the cell will again furnish a large current. This action is familiar to anyone who has had to use a flashlight for several hours, until the light was too dim to be of any use, only to find the original brilliance restored the following evening. With the lapse of time, or continued use, the dry-cell deteriorates due to loss of moisture or the using up of the zinc; this is shown by a decrease in the current it will supply and not by a drop in rated voltage—in fact, voltage will remain fairly constant during the life of the dry-cell.

The amounts of the basic constituents (zinc, carbon, manganese dioxide) are sufficient to permit the depolarizing effect to stay in line with the liberation of hydrogen, as long as the

battery is operated at its *rated* drain. If the maximum permissible current discharge rate is exceeded for any great period of time, the battery will be ruined.

The action of the dry-cell battery is a function of the chemicals, and when completely exhausted, not just polarized, it is necessary to replace the chemicals, i.e., get a new dry cell. The storage battery utilizes an entirely opposite action, for it is composed of plates and chemicals that *store* electric energy but do not create it. Consequently, the storage battery can be recharged after it has been used for a length of time, without the costly replacement of chemicals.

During the discharge, the chemical composition of the storage battery changes and the amounts of the original constituents decrease. The battery can be recharged by breaking up the compounds formed during discharge and permitting the elements of the broken-up compounds to return to their original state. The process necessary to accomplish this recharging is to pass a current through the battery in a direction *opposite to normal current flow*, thus causing the water formed originally by the combination of hydrogen and oxygen to be broken up into free hydrogen and oxygen. The hydrogen and oxygen then recombine with other chemicals in the battery and thus reverse the original process of discharge. Since sufficient time must be given for these recombinations to occur, the process must be done at a rate which will permit the water to be changed into hydrogen and oxygen. The charging rate of the battery charging circuit should fall to zero automatically when the battery has been recharged completely. If the rate of recharging is too rapid the gases will form so rapidly that the battery unit will swell, breaking the pitch or wax sealing and permitting the gases to escape. If the charge continues after all of the water is broken up into hydrogen and oxygen, it will cause other chemical reactions harmful to the battery.

## A Rectifier Tube Battery Charger

In the Stewart Warner Model 9007, page 15-42 of Rider's Vol. XV, they employ an A-B

dry-cell battery pack (90 volts B supply and 9 volts A supply). In order to prolong the life of these dry cells they use a unique battery-charger circuit for this dry cell. In other words a dry cell can have energy somewhat restored for a certain amount of time by a process of recharging so that its life can be extended. The circuit for this is illustrated in Fig. 1. The 35Z5GT tube marked with the numeral 1 supplies the usual direct current for the receiver. The basic battery charging circuit makes use of the 35Z5GT rectifier tube designated with the numeral 2 and a resistor voltage-dividing network, as shown in Fig. 2. The circuit is designed so that the current through resistors 49A and 49B is large in comparison to the charging currents  $I_a$  and  $I_b$ . Variations in charging current therefore will not affect the voltages  $E_1$  and  $E_2$  greatly, so that the "A" and "B" battery voltages will be substantially constant. This charger recharges all four batteries regardless of whether the batteries are part of a single unit pack or are individual units. The circuit design is such that the charging rate is approximately one-third of the discharge rate, this ratio producing the best results. Resistors 45 and 47 are current-limiting resistors to prevent the charging currents from exceeding a value which might cause the battery to produce too much gas.

A simplified representation of the flow of charging and discharging electron currents appears in Fig. 3. The discharging electron current  $A$  flows from the negative terminal of the battery, through load  $R$  and back to the positive side of the battery. The charging

FIG. 1.—Battery charging and rectifier circuit used in the Stewart Warner Model 9007. Switch 43 is for changing from a-c or d-c operation to batteries and also for charging the latter.

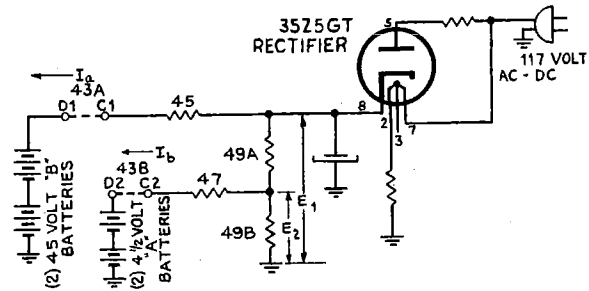
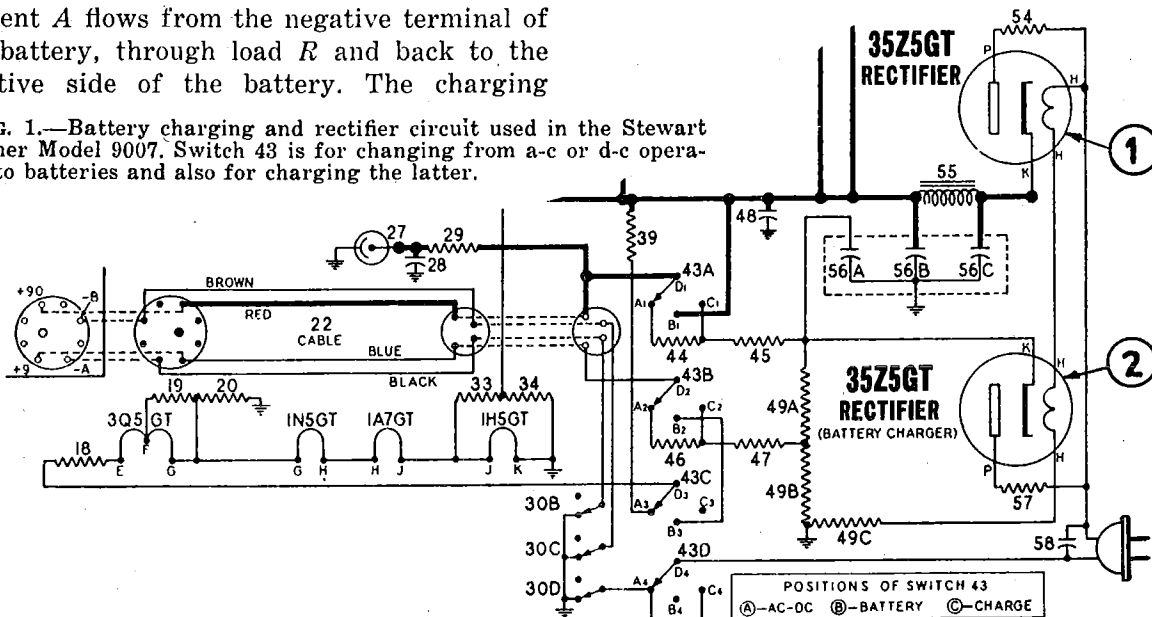
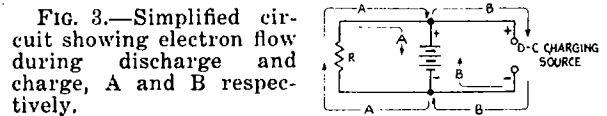

FIG. 2.—The basic battery-charging circuit, incorporating rectifier 2 of Fig. 1.

electron current  $B$  flows from the negative side of the d-c charging source (in this case, a 35Z5GT rectifier tube), through the battery in opposition to the discharging current, and back to the positive side of the charging source. As explained previously, the passage of a current through a battery in a direction opposite to normal electron current flow causes it to charge.



It had been stated that the charging rate should fall to zero when the battery has been completely recharged. That the charger used in this receiver does this may be seen from an examination of Fig. 4. These graphs illustrate the manner in which the charging current for both the "B" and "A" batteries depend upon

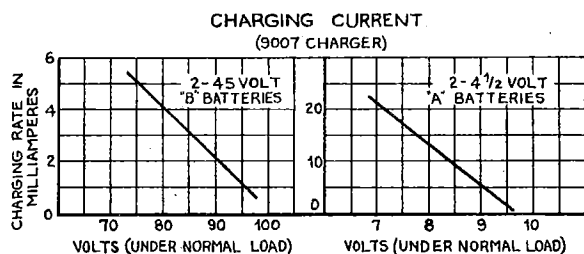

FIG. 4.—Graphs showing how the charging current of the batteries falls as they approach a charged condition.

the voltage output. When the battery voltage is low, the charging current is high and therefore the charging rate is high; when the battery is fully charged, the charging current is almost zero and the charging rate is negligible.

When a fully charged storage battery is first used in a set, it will operate at maximum efficiency for only a few hours. If it is kept properly charged, its life will not only be lengthened greatly but receiver performance will remain at a high level. The sensitivity of a radio receiver will decrease if the supply voltage decreases; proper charging means that the batteries will always operate at a sufficiently high level so that maximum receiver sensitivity is obtained.

The results of a life test run on two 45-volt "B" batteries is shown by the three graphs in Fig. 5. The manufacturer of these batteries claims that if they are discharged six hours a day they will last for 115 hours before reaching the limiting value of 67 volts. However, Fig. 5 shows that periodic charging tremendously lengthens the useful life of the battery.

The left hand graph shows that the batteries are charged up to 92 volts when first inserted in the set. After nine hours of discharging the voltage has dropped to 85 volts and the battery is charged for 15 hours. Each succeeding discharge cycle of ten hours results in a slightly lower end voltage, and after 500 hours the battery has been reduced to 78 volts. However, the application of regular periods of charge still results in an adequate battery voltage. Even after a thousand hours of operation the batteries could still be charged to 83 volts, although the drop in voltage after ten hours of use is down to the limiting point of 67 volts.

A means of indicating the battery condition is also provided in this circuit. A neon lamp (item 27 in Fig. 1) is connected to an R-C

circuit (items 29 and 28). The neon lamp will light up at a certain voltage and be extinguished at a certain voltage, so that these three items constitute an oscillating circuit whose rate of oscillation depends upon the neon tube, the values of R and C, and the applied voltage. The constants are so chosen that the neon lamp will flicker about three times a second when the batteries are fully charged. (The true condition of the batteries is only indicated when switch 43 is in the "Battery" position. When it is in the "Charge" or "AC-DC" position, the neon lamp flashes rapidly but does not indicate whether or not the battery is fully charged.) The battery voltage decreases as the receiver is used, and consequently the number of flashes from the neon lamp will decrease. When the battery voltage has dropped to about 72 volts the lamp flashes about once a second. This is a warning that the receiver should not be operated from battery power and that recharging should be accomplished immediately.

The batteries should be charged for at least twice as long a time as they were in use, and as soon as possible after they have reached the point of one neon flash per second. For example, if the receiver was battery operated for four hours during the day, it should be recharged for about eight hours that same night. As the batteries age, it will be necessary to charge them for a longer period each time, and it will also be necessary to charge them more frequently. It should be remembered that a completely discharged battery cannot be recharged satisfactorily, and that only a small amount of charging takes place when the receiver is operated on a.c. or d.c. This small current is sufficient to prevent the batteries from deteri-

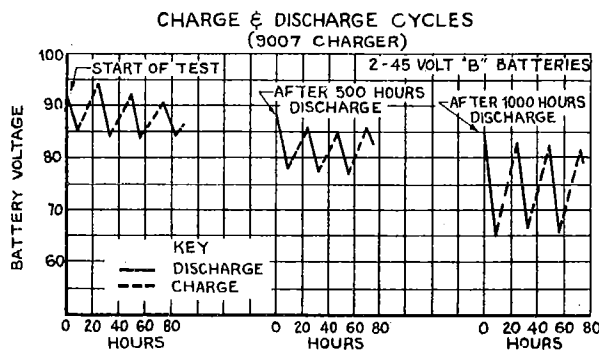

FIG. 5.—Discharge and charge cycles of two 45-volt dry batteries, showing that by periodic charging their useful life is greatly extended.

orating, but is not enough to recharge them; a battery will deteriorate if permitted to stand idle for several months, and this action prevents it. A separate charging position of the selector switch is provided for the regular charging operation, as shown in Fig. 1.

When the receiver is connected to a d-c line, the polarity of the connection should be checked, by turning the receiver on, before attempting to charge the batteries. From Fig. 1 it is seen that the batteries will discharge when the "ON-OFF" switch is left in the "ON" position, even when the power cord is not connected to a source of power.

The charging operation should be undertaken regularly, and not only when the battery voltage is low. The condition of the battery should be checked frequently, by noting the rate at which the neon lamp flickers when the selector switch is in the "Battery" position. If the receiver is not used for a long time, the battery should be charged for several hours every few weeks to prevent deterioration. The receiver should be operated from an a-c or d-c source of power, whenever possible, in order to save the battery.

A Copper-Oxide Battery Charger

The power supply and battery-charger circuit of the General Electric Model 250, page 15-32 of Rider's Vol. XV, is reproduced in Fig. 6. This receiver is operated by a 2-volt storage type built-in rechargeable battery (B1). The battery can be charged from an automobile or 6-volt storage battery by connecting a special charging cable from the two connector pins on the receiver to a 6-volt d-c supply. Provision is

also made for charging the battery from a 115-volt, 60-cycle line, as indicated in Fig. 6; when this is done the battery "floats" and is being charged at a slow rate.

The A+ power needed for the 1.4-volt tube filaments is obtained directly from battery B1, using R18 as a dropping resistor. The B+ power required by the receiver tubes is obtained from the synchronous vibrator, V1, a step-up transformer, T5, and a filter circuit (C32, L6, C26-A, R17, and C26-B) in a fashion that will be discussed later.

The power switch is a three-position selector switch; in the "OFF" position, the receiver does not operate and the battery cannot be charged; in the "ON" position, the receiver operates from the battery, B1, and if it is connected to the a-c line, it is possible to maintain the battery charge from the rectified line current; in the "CHG" position, the receiver does not operate and the battery can be charged.

The operation of charging from the a-c line is similar to the action that takes place with an automobile receiver. If the car battery is run down, and the motor is not running, the receiver volume is low even though the volume control is at a maximum; if the motor is idling the receiver output will increase, and at normal motor speed the receiver volume will be greatly increased. However, if the auto battery is fully charged, it will be noticed that the motor speed has no effect on the receiver volume. When we speak of the motor speed we are referring to the generator or battery-charger output; actually what is taking place is that with a poorly charged battery the addition of the battery-charger voltage, when the motor is run-

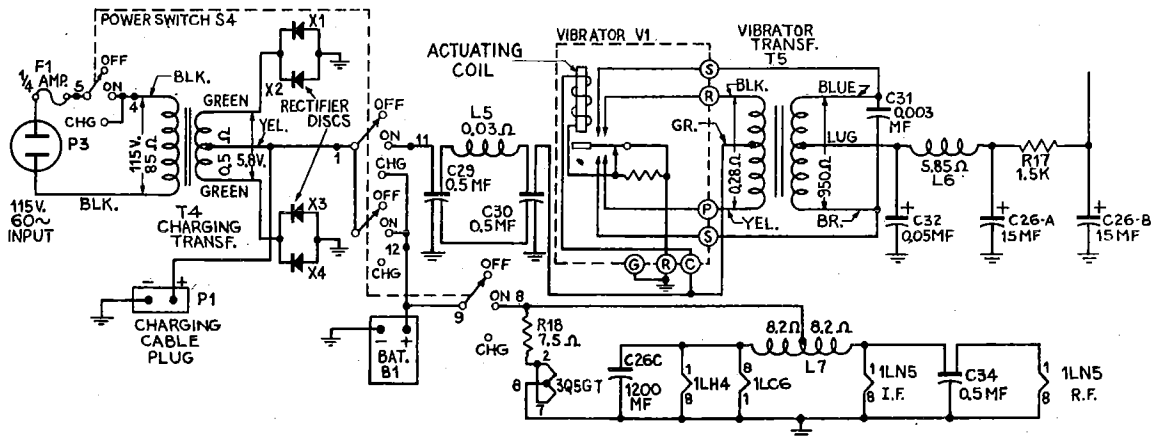

FIG. 6.—Power-supply and battery-charging circuits of the General Electric Model 250. The set is operated by a 2-volt storage battery, which can be charged from an automobile battery or a 115-volt a-c line.

ning, acts to increase the battery voltage, thus increasing the B supply and consequently the receiver output. With a fully charged battery, the battery voltage is affected only slightly by the addition of the generator, and the battery is said to be "floating" in the circuit.

The reason for a fully charged battery being affected only slightly by the addition of a power source is that its characteristics are somewhat similar to a very-high valued electrolytic capacitor. A battery charger, battery, and load may be represented by the equivalent circuit shown in Fig. 7. The copper-oxide rectifiers,

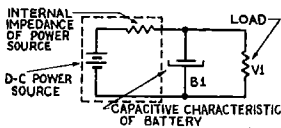

FIG. 7.—Equivalent circuit of a battery and charger, and the load.

$X1$  to  $X4$ , and associated transformer  $T4$  of Fig. 6 are here represented as a battery; receiver battery  $B1$  is shown as an electrolytic capacitor, and vibrator  $V1$ , with associated components, is shown as a resistor.

The discharge circuit of Fig. 7 consists of the capacitor and resistor, i.e.,  $B1$  and  $V1$ . Due to the high equivalent capacitance the circuit has a large time constant, which, in seconds, is obtained by multiplying the capacitance, in farads, by the resistance, in ohms. Therefore, a small change in voltage from the d-c power source (i.e., battery charger) would not affect the capacitor (i.e.,  $B1$ ) voltage until after the period of the large time constant.

From this description of the equivalent circuit, the effect of the a-c power line variations is seen to be minimized. Such variations are momentary, the battery-charger fluctuations will be momentary, and the large capacitive characteristic of  $B1$  prevents any change in the battery voltage level, regardless of line and battery-charger variations.

The actual operation of the battery charger can be followed in Fig. 6. When the power cable is connected to the a-c line and the selector switch is turned to "CHG" or "ON," the step-down transformer,  $T4$ , reduces the 117 volts to 5.8 volts. The full-wave copper-oxide rectifier circuit rectifies this voltage and supplies a charging current to battery  $B1$ .

The "B+" voltages are effectively obtained from battery  $B1$ . Its voltage is converted into pulsating direct current by one set of contacts of the synchronous vibrator,  $V1$ . The a-c com-

ponent of this pulsating voltage appears across the primary of  $T5$ , and is stepped up so that a high-voltage alternating current is available at the secondary. This high voltage is now fed back to the second set of vibrator contacts, which rectifies it and thus provides a high-voltage pulsating direct current to the center tap of the  $T5$  primary. The  $T5$  secondary output is filtered by  $C32$ ,  $L6$ ,  $C26-A$ ,  $R17$ , and  $C26-B$ , thus providing the required high-voltage direct current used by the tubes. There is provided between the battery,  $B1$  and the vibrator,  $V1$ , a filter network consisting of  $C30$ ,  $L5$ , and  $C29$ —this prevents r.f., created by the sparking of the vibrator contacts, from being fed back from the vibrator circuit into the filament circuit of the tubes.

The actual operation of the vibrator is sufficiently interesting to call for closer examination. The battery output is impressed on the vibrator, which by its mechanical action alternately impresses this voltage on either side of the center-tapped primary. An alternating current is thus produced in the secondary, which can be readily rectified into a high-voltage direct current. The vibrator performs two functions, that of interrupting the direct current from the battery and that of rectifying the high-voltage alternating current from the transformer secondary. This type of vibrator is usually known as the synchronous type, because it interrupts and rectifies in synchronism. The synchronous vibrator is thus used to replace a rectifier tube, with a consequent reduction in cost.

#### Battery Economizer Circuit

Some portable receivers which do not have rechargeable batteries make use of an "economizer" switch to prolong the life of the battery. In the Galvin (Motorola) Model 45B12, page 15-27 of Rider's Vol. XV, this switch is termed the "Battery-Saver Switch." It is placed in the "LD" (low drain) position when the battery is new, and in the "HP" (high power) position when the battery is run down; in either position it affects the drain on both the "A" and "B" batteries.

The components that concern the "B" battery are shown in Fig. 8. The 3Q5GT power-amplifier tube employs fixed bias, using  $R10$  and  $R11$  which are in series with the grid resistor,  $R9$ . When the "Battery-Saver Switch,"

*S-1*, is closed, it shorts out *R11* to ground. When the battery is new, *S-1* is opened so that the output tube is strongly biased, thus reducing the plate and screen currents of all the tubes. This comes from *R11* being in series with *R10*, which increases the voltage drop between B— and ground and imposes a higher negative voltage on the 3Q5GT grid. The increased voltage drop across the output-tube bias resistor results in less current being drawn by the plate and screen.

The voltage available from the "B" battery decreases with use and time, and the closing of switch *S-1* will short out *R11* and thus reduce the total resistance of the self-biasing resistance. This means that the bias on the tube is decreased and therefore the plate current is increased. The power output of the receiver will increase, and less distortion will be present than if the switch was left open.

The life of the battery is greatly increased because of the reduced drain when it is new, for the battery can be used even after its output has been reduced. If the switch was not present, then the reduced plate and screen voltages would cause a decrease in sensitivity and a distortion of the power output, requiring earlier battery replacement. If *R11* was not present, then the initial drain on the battery would be higher and it would have to be replaced in a shorter period than the "economy" circuit provides. Of course, when the battery is new and the switch is left open as recommended, the power output is less than it could be and more

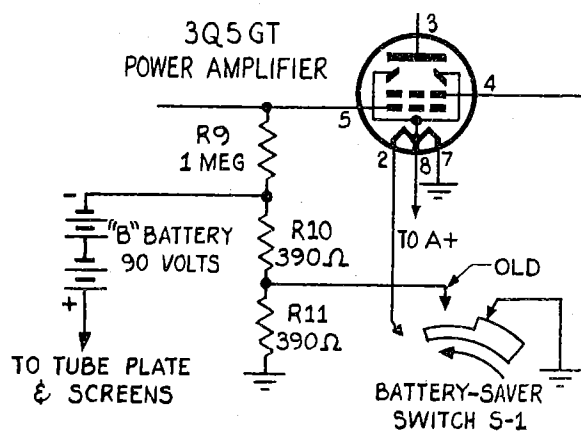
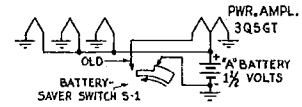

FIG. 8.—Components of the Motorola Model 45B12 "battery saver" circuit.

distortion is present, but so far as the listener is concerned the operation is satisfactory. At least, the owner is offered the choice of maximum receiver performance and normal battery

FIG. 9.—The 1.4-volt filaments of the Motorola Model 45B12 are in parallel across the 1.5-volt dry "A" battery.



drain, or satisfactory receiver performance and long battery life.

The components that concern the "A" battery are shown in Fig. 9. The 1.4-volt filaments of the various tubes are connected in parallel across the 1.5-volt "A" battery. The 3Q5GT has a two-section filament; connected in series when the tube is operated with a 2.8-volt supply, and in parallel when operated with a 1.5-volt filament supply; in either case the filament power is the same. When *S-1* is open (for a new battery) the 3Q5GT tube in this receiver is operated with only one section of the filament, the other section being open. When the battery is old and the switch is closed, the second section of the filament is thrown in parallel with the first section, which is the normal method of connecting the filament for a 1.5-volt supply.

Operating the 3Q5GT tube at half this rated-filament power when the battery is new, will not ruin the tube, since at the same time the plate and screen currents are reduced and the tube bias increased, as has been previously explained. The use of the "Battery-Saver Switch" lengthens the "A" battery life in the same fashion that it did the "B" battery life.

The design of the Galvin Model 45B12 receiver case, governed by portability considerations, requires that an "A-B" battery-pack be used. An "A-B" pack is an "A" battery and a "B" battery assembled in a single container. Since the two batteries are not removable separately, the one that becomes exhausted first determines the useful life of the entire pack. Thus the use of the "Battery-Saver Switch" in this receiver for lengthening the life of both batteries simultaneously, makes their discharge rates approximately the same, and therefore the "A" and "B" batteries will become exhausted at approximately the same time.



**CONCORD  
EMPIRE**

CONCORD RADIO CORP.

MODEL		PAGE
6C51B, 6C51W	Schematic, voltage, alignment, socket, dial data	16-1
7G26C	Schematic, voltage, parts layout, dial data, coil data, selectivity, sensitivity	16-2
	<i>Clarified schematics</i>	16-3
	Alignment, trimmers, parts list	16-4

CORONADO

See GAMBLE-SKOGMO INC.

CORONET RADIO & TELEVISION CO.

1583	Schematic, sockets	16-1
	<i>Clarified schematics</i>	16-2
1701	Schematic	16-3
	<i>Clarified schematics</i>	16-4

CROSLY DIV. -AVCO MFG. CORP.

56FC	Schematic, cabinet, socket, trimmers	16-1
	<i>Clarified schematics</i>	16-2
56TD	Voltage, parts, alignment	16-3
	Schematic, voltage	16-4
	Socket, trimmers, cabinet, alignment	16-5
	Parts list	16-6
56TN-L	Schematic, voltage	16-7
	<i>Clarified schematics</i>	16-8
	Cabinets, socket, trimmers, alignment	16-9
	Parts list	16-6
56TX-L	Schematic, voltage	16-12
	<i>Clarified schematics</i>	16-2
	Socket, trimmers, alignment	16-13
	Parts list	16-6
56TZ, 57TQ 1st and 2nd Production	Schematics, cabinets, dial data	16-10
	Record Changer, V-M Model 400	RCD.CH.15-1
	Socket, trimmers, alignment, voltage	16-11
	Parts list	16-6
56XTA, 56XTW	Schematic, voltage	16-14
	<i>Clarified schematics</i>	16-8
	Socket, trimmers, cabinets, alignment	16-15
	Parts list	16-19
57TQ	See Model 56TZ	
66CS, 66CSM, 66CS(s)	Schematics	16-16
	Record Changer, Seeburg Model K	RCD.CH.15-2
	Socket, trimmers, alignment	16-17
	Cabinets, voltage	16-18
	Parts list	16-19
66TC-S	Schematic, voltage	16-20
	<i>Clarified schematics</i>	16-21
	Socket, trimmers, alignment, cabinet	16-22
	Parts list	16-19
86CR, 86CS	Schematic, socket, trimmers, cabinet	16-23, 24
	<i>Clarified schematics</i>	16-25
	Voltage, socket, trimmers	16-26
	Alignment	16-27
	Alignment, dial data	16-29
	Parts list	16-30

CLARION

See WARWICK MFG. CO.

CORONADO

See GAMBLE SKOGMO INC.

DETROLA

See INTERNATIONAL DETROLA CORP.

DEWALD RADIO MFG. CORP.

A-507	Schematic, battery data, voltage, cabinet	16-1
A-509	Schematic, alignment	16-2
	<i>Clarified schematics</i>	16-3

EDWARD'S FM RADIO CORP.

FM Tuner	Schematic, notes	16-1
	Antenna data, socket, trimmers	16-2

ELECTRONIC CORP. OF AMERICA

MODEL		PAGE
201	Schematic, voltage	Misc.16-3

ELECTRONIC LABORATORIES, INC.

Orthosonic	See Model 710T	
Radio Utiliphone	See Model 76RU	
76RU, Radio Utiliphone	Schematic, voltage, notes	16-1
Chassis 2865	Alignment, chassis, notes	16-2
	Alignment, selectivity, sensitivity, dial data	16-3
	Sub-station data, tube data, notes	16-4
710T, Orthosonic,	Schematic, voltage	16-5
Chassis 2875	Alignment, tube data, chassis, miscellaneous notes	16-6
	Alignment, selectivity, sensitivity, dial data	16-7
2811	Schematic, socket	16-8
2865, Chassis	See Model 76RU	
2875, Chassis	See Model 710T	

EMERSON RADIO & PHONOGRAPH CORP.

503, 510, 510A, 520, 539	Schematics	16-1
Chassis 120000, 120029, 120030, 120032, 120035, 120044	Alignment, voltage	16-2
	Parts list, notes	16-3
505, Chassis 120020	Schematic, battery data	16-4
	Alignment, coil and trimmer data, battery data, parts list	16-5
	Voltage	16-7
505, 523, Chassis 120041	Schematic, notes	16-6
	Alignment, coil and trimmer data, battery data, parts list	16-5
	Voltage	16-7
507, 509, 518, 522, 535, Chassis 120004, 120045	Schematic, notes	16-8
510, 510A	Alignment, voltage, parts	16-2
518	See Model 503	
520	See Model 503	
522	See Model 507	
523	See Model 505, Chassis 120041	
524, Chassis 120011, 524-2,	Schematic, notes	16-9
Chassis 120022	<i>Clarified schematics</i>	16-10
	Alignment, adjustments, dial data	16-12
	Parts list, voltage	16-13
525, 552, Chassis 120037	Schematic	16-14
	Alignment, voltage	16-2
	Voltage, parts list, notes	16-7
531, 532, 533, Chassis 120040	Schematic, notes	16-15
	Voltage, alignment, parts list, dial data	16-16
	See Model 507	
	See Model 503	
535		
539		
543, 544, Chassis 120046	Schematic	16-17
	Alignment, voltage	16-2
543, 544, Chassis 120052	Schematic, notes	16-18
	Alignment, voltage	16-2
	See Model 525	
552		
1002, 1003, Chassis 129003	Schematic	16-19,
	Alignment, voltage, parts list, dial data	16-20.
120000, Chassis	See Model 503	
120004, Chassis	See Model 507	
120011, Chassis	See Model 524	
120020, Chassis	See Model 505, Chassis 120020	
120022, Chassis	See Model 524-2	
120029, 120030, 120032, 120035, Chassis	See Model 503	
120037, Chassis	See Model 525	
120040, Chassis	See Model 531	
120041, Chassis	See Model 505, Chassis 120041	
120044, Chassis	See Model 503	
120045, Chassis	See Model 507	
120046, Chassis	See Model 543, Chassis 120046	
120052, Chassis	See Model 543, Chassis 120052	
129003, Chassis	See Model 1002	

EMOR RADIO, LTD.

100	Schematic, miscellaneous data, cabinet	16-1
	<i>Clarified schematics</i>	16-2

EMPIRE DESIGNING CORP.

55	Schematic, socket	Misc.16-4
56	Schematic, socket	Misc.16-4



<u>ESPEY MFG. CO., INC.</u>		PAGE
MODEL		
FJ-97A, Chassis Revised	Schematic	16-1
	Clarified schematics	16-2
5181	Schematic	16-3
	Clarified schematics	16-4
	Voltage, socket, trimmers, alignment	16-6
<u>FADA RADIO &amp; ELECTRIC CO., INC.</u>		
172	Schematic	16-1
	Clarified schematics	16-2
<u>FARNSWORTH TELEVISION &amp; RADIO CORP.</u>		
BT-68	Schematic	16-1
	Alignment, voltage and resistance	16-2
EK-081, EK-082, EK-083, EK-681, Chassis C-156, C-157, C-193	Schematic, voltage and resistance	16-3
	Record Changer, Farnsworth Model P-51 RCD. CH.	15-1
	Clarified schematics	16-4
	Alignment, socket, trimmers, dial data, parts list, coil data, pushbutton data	16-5
GK-140, GK-141, GK-142, GK-143, GK-144, Preliminary	Schematic, voltage and resistance, coil connections	16-7, 8
	Clarified schematics	16-9
	Alignment, socket, trimmers, dial data, coil data	16-10
	Alignment	16-11
	FM alignment, oscillograms	16-6
<u>FEDERAL TEL. &amp; RADIO CORP.</u>		
E1025TB	Schematic, socket, resistance and voltage	16-1
	Clarified schematics	16-2
	Alignment, socket, trimmers	16-3
	Chassis layout, parts list	16-4
1030T, 1540T	Schematic, parts layout, coil data, dial data	16-5
	Clarified schematics	16-6
	Voltage and resistance, parts list	16-7
	Alignment, socket, trimmers	16-8
<u>FERGUSON RADIO CORP.</u>		
5X47	Schematic	Misc. 16-5
7X47	Schematic	Misc. 16-5
<u>THE FIRESTONE TIRE &amp; RUBBER CO.</u>		
Brilliantone	See Model 7403-1	
Roamer	See Model 7402-6	
4-A-17	Schematic	16-1
	Record Changer, Detrola Model 550 RCD. CH.	15-1
	Alignment, voltage, socket, trimmers, cabinet, notes	16-2
	Stage gain, dial data	16-9
7379-1, 7405-3, 7406-1	Schematic, voltage, notes	16-3
	Clarified schematics	16-4
	Alignment, socket, trimmers, parts list	16-5
7383-4	Schematic, socket	16-6
	Alignment, dial data	16-7
	Voltage, notes	16-8
7396-1	Schematic	16-9
	Parts list, alignment	16-10
	Cabinet, voltage, notes	16-11
7402-6, Roamer	Schematic, battery data, cabinet	16-12
	Alignment, voltage, notes	16-13
	Parts list, socket, trimmers	16-8
7403-1, Brilliantone	Schematic, socket, trimmers, voltage, notes	16-14
	Alignment, parts list	16-11
7405-3, 7406-1	See Model 7379-1	
<u>GAMBLE-SKOGMO INC.</u>		
43-7601, 43-7601A, 43-7601B	Schematic, dial data, selectivity, sensitivity	16-1
	Clarified schematics	16-2
	Socket, trimmers, alignment, coil data, voltage, changes	16-3
	Parts layout, cabinet	16-4
	Parts layout	16-5
43-7602	Schematic, dial data, selectivity, sensitivity	16-1
	Clarified schematics	16-2
	Socket, trimmers, alignment, coil data, voltage, changes	16-3
	Parts layout	16-4
	Parts layout	16-5
	Parts layout, cabinet	16-6
43-8160	Schematic, voltage, alignment	16-7

<u>GAMBLE-SKOGMO INC. (Cont'd.)</u>		PAGE
MODEL		
43-8160 (Cont'd)	Cabinet, coil data, parts layout	16-8
	Parts layout, socket, trimmers, dial data, selectivity, sensitivity	16-9
43-8437	Schematic, alignment, dial data, voltage, trimmers, socket, selectivity, sensitivity	16-10
	Parts layout	16-11
	Cabinet, notes, parts list	16-12
43-8576	Schematic, coil data, voltage, selectivity, sensitivity	16-13
	Clarified schematics	16-2
	Dial data, alignment, trimmers, notes	16-14
	Cabinet, parts layout	16-15
	Parts layout	16-16
<u>GAROD ELECTRONICS CORP.</u>		
The Companion	See Model 5A1-Y	
The Ensign	See Model 5A1	
5A1, The Ensign	Schematic, socket, trimmers, cabinet	16-1
	Alignment	16-2
5A1-Y, The Companion	Schematic, alignment, socket, trimmers, cabinet	16-2
5D-3, 5D-3A	Schematic, battery data, cabinet	16-3
	Alignment, socket, trimmers, cabinet, battery data	16-4
<u>GENERAL ELECTRIC CO.</u>		
180	Schematic, cabinet	16-1
	Alignment, socket, trimmers, voltage, stage gain data, dial data, notes	16-2
254	Schematic, cabinet, voltage	16-3
	Alignment, socket, trimmers, voltage, stage gain data	16-4
	Parts layout, parts list	16-5
260	Schematic, voltage, dial data, socket, trimmers, cabinet	16-7, 8
	Parts list, terminal data, wiring data, notes	16-6
	Clarified schematics	16-9
	Alignment, stage gain and voltage data, socket, trimmers	16-11
	Alignment, battery data	16-12
	Schematic, socket, cabinet, notes	16-13
	Clarified schematics	16-14
	Alignment, socket, trimmers, dial data, stage gain and voltage data, switch wiring data	16-15
	Parts list	16-16
	Schematic, notes	16-17, 18
	Clarified schematics	16-19
	Parts list, dial data, notes	16-16
	Voltage, switch wiring data, stage gain and voltage data	16-21
	Alignment	16-22
	Alignment, socket, trimmers, cabinet	16-23
	Band switch wiring data	16-24
801	Schematic, cabinet, notes	16-25, 26
	Amplifier, converter and oscillator data	16-27
	Amplifier, multivibrator and voltage data	16-28
	Voltage data, alignment	16-29
	Alignment	16-30
	Alignment, dial data, miscellaneous data	16-31
	Miscellaneous adjustment data	16-32
	Changes, operation data, service notes	16-33
	Service notes, voltage	16-34
	Alignment	16-35
	Alignment, waveform measurements	16-36
	Chassis layouts, waveform measurements	16-37
	Parts list	16-38
<u>GENERAL TELEVISION AND RADIO CORP.</u>		
4B5	Schematic, cabinet, stage gain data	16-1
	Dial data, socket, trimmers, parts layout, alignment	16-2
5B5	Schematic, stage gain data, cabinet	16-3
	Voltage and resistance, socket, trimmers, parts layout, alignment	16-4

GEN TEL  
LEAR

GENERAL TELEVISION AND RADIO CORP. (Cont'd)

MODEL		PAGE
5B5 (Cont'd)	Dial data	16-2
9A5	Schematic, stage gain data, voltage and resistance, socket, trimmers, parts layout	16-5
23A6	Dial data	16-2
	Alignment	16-4
	Schematic, stage gain data, cabinet, voltage and resistance, socket, trimmers, parts layout	16-6
	Dial data	16-2
	Alignment	16-4
24B6	Schematic, stage gain data, cabinet	16-7
	Socket, trimmers, parts layout, voltage and resistance	16-8
	Dial data	16-2
	Alignment	16-4
25B5	Schematic, stage gain data, cabinet	16-9
	Socket, trimmers, parts layout, voltage and resistance	16-10
	Dial data	16-2
	Alignment	16-4

GILFILIAN BROS., INC.

Overland	See Model 66B	
56A, 56B, 56C, 56D, 56E	Schematic, voltage, alignment, socket, trimmers, notes	16-1
66AM, 66DM	Schematic, voltage, alignment, socket, trimmers, notes	16-2
66B, Series 2, Series 3, Overland	Schematics, voltages, alignments, sockets, trimmers, battery data	16-3
66DM	See Model 66AM	
66PM	Schematic, voltage, alignment, socket, trimmers	16-4
	Record Changer, General Instrument Model 204	RCD.CH. 15-1
86 Series	Schematic, voltage, alignment, socket, trimmers, dial data, notes	16-5
	Record Changer, Webster Model 56	RCD.CH. 15-10
	Clarified schematics	16-6

B.F. GOODRICH CO.

(MANTOLA)

R-635	Schematic	16-1
	Clarified schematics, push-button data	16-2
	Socket, trimmers, alignment, notes	16-3
	Pushbutton and electric tuner data	16-4
R-661	Schematics, switch data	16-5
	Socket, trimmers, alignment, voltage, parts list	16-6

GRANTLINE

See W.T. GRANT CO.

W.T. GRANT CO.  
(GRANTLINE)

500, 501, Series A	Schematic, coil data, dial data, selectivity, sensitivity, notes	16-1
	Socket, trimmers, voltage, alignment, cabinet, coil data	16-2
	Parts list	16-5
502, 503, Series A	Schematic, voltage, push-button data, cabinet, selectivity, sensitivity, notes	16-3
	Coil data, dial data, socket, trimmers, alignment, notes	16-4
	Parts list	16-5
510, Series A	Schematic, notes, voltage	16-6
	Dial data, socket, trimmers, battery data, cabinet, alignment, selectivity, sensitivity	16-7
	Parts list, cabinet, miscellaneous notes	16-8

THE HALLICRAFTERS CO.

Skyranger	See Model S-39	
Super Skyrider	See Model SX-28A	
EC-1B, Echophone	Schematic, socket, trimmers, alignment	16-1

THE HALLICRAFTERS CO. (Cont'd)

MODEL		PAGE
EC-1B, Echophone (Cont'd)	Clarified schematics	16-2
EC-403, EC-404, Echophone	Schematic, pushbutton data, notes	16-29, 30
	Clarified schematics	16-31
	Parts layouts, trimmers	16-34
	Alignment, socket, trimmers, voltage, dial data	16-35
	Parts list, cabinet	16-36
S-39, Skyranger	Schematic, notes	16-20
	Clarified schematics	16-21
	Trimmers	16-22
	Voltage, alignment	16-23
	Parts layout, cabinet	16-24
	Parts layout, battery data	16-25
	Parts list	16-26
	Parts list, antenna data	16-28
SX-28A, Super Skyrider	Schematic, switch data, notes	16-3, 4
	Clarified schematics	16-5
	Parts layouts	16-8
	Terminal connections notes, operation	16-9
	Operation	16-10
	Voltage, audio curves, a.v.c. curve	16-13
	Trimmers, cabinet	16-14
	Alignment, miscellaneous service notes	16-15
	Parts list	16-16

HOFFMAN RADIO CORP.

A202, A309, Chassis 119	Schematic, voltage, chassis, notes	16-1
	Alignment	16-2
A700, Chassis 1105	Schematic, alignment, socket, trimmers, chassis, voltage	16-4
B400, Chassis 118	Schematic, chassis, voltage, notes	16-3
	Record Changer, Aero Model 46A	RCD.CH. 16-1
	Alignment	16-2
110S, Chassis 118, Chassis 119, Chassis	See Model A700	
	See Model B400	
	See Model A202	

HOWARD RADIO CO.

M901-A, 901-A	Schematics, sockets, trimmers	16-1
901-AP-A	Schematic, socket, trimmers	16-2
906	Schematic, notes	16-3
	Voltage, parts list, alignment, socket, trimmers, antenna notes, cabinet	16-4
906C	Schematic, socket, trimmers, cabinet	16-5
	Voltage, alignment, socket, trimmers, antenna notes	16-4
	Dial data, notes, parts list	16-6

INTERNATIONAL DETROLA CORP.

582	Schematic	16-1
	Clarified schematic	16-2
	Alignment, socket, trimmers, dial data	16-3
	Voltage, parts layout, parts list	16-4
7270	Schematic	16-5
	Cabinet, socket, trimmers, alignment, voltage, gain data	16-6
	Dial data	16-3

KNIGHT

See ALLIED RADIO CORP.

LAFAYETTE

See RADIO WIRE TELEVISION

LAUREHK RADIO MFG. CO.

L-52	Schematic	Misc. 16-6
------	-----------	------------

LEAR, INC.

565, 565BL, 566, 567, 568	Schematic	16-1
	Loop, socket, trimmers, alignment	16-2
	Dial data, voltage	16-3
662, 663, 665, 6618	Schematic	16-4
	Voltage, dial data, loop	16-5
	Alignment, socket, trimmers	16-6
6614, 6615, 6616, 6619	Schematic, loop	16-7



**MOTOROLA  
RCA**

MOTOROLA, INC. (CONT'D)

MODEL		PAGE
CT6, OE6, PC6 (Cont'd)	Socket, trimmers, voltage, resistance	16-15
	Alignment, sensitivity, notes	16-16
	Parts list	16-17
	Chassis	16-12
	Chassis	16-13
	Chassis	16-14
	Parts layout	16-18
	Pushbutton data	16-6
	I-F transformer notes	16-7
	Chassis	16-19
	Dial data, voltage notes	16-20
	Socket, trimmers, voltage, notes, resistance	16-21
	Parts list	16-22
	See Model CT6	
	Schematic, notes	16-23
	Pushbutton data	16-6
	I-F transformer notes	16-7
	Alignment, socket, trimmers	16-24
	Parts layout	16-25
	Chassis	16-26
	Voltage, resistance, dial data	16-27
	Parts list	16-28
	Chassis	16-29
	I-F transformer notes	16-7
	Alignment, sensitivity, notes	16-16
	Socket, trimmers, cabinet, sensitivity	16-33
	Voltage, resistance	16-35
	Parts list	16-36
	Chassis	16-30
	I-F transformer notes	16-7
	Alignment, sensitivity, notes	16-16
	Socket, trimmers, cabinet, sensitivity	16-33
	Voltage, resistance	16-35
	Parts list	16-36
	Chassis	16-31
	I-F transformer notes	16-7
	Alignment, sensitivity, notes	16-16
	Socket, trimmers, cabinet, sensitivity, notes	16-33
	Pushbutton data	16-34
	Voltage, resistance	16-35
	Parts list	16-36
	Chassis	16-32
	I-F transformer notes	16-7
	Alignment, sensitivity, notes	16-16
	Socket, trimmers, cabinet, sensitivity, notes	16-33
	Pushbutton data	16-34
	Voltage, resistance	16-35
	Parts list	16-36

NATIONAL ACOUSTIC PRODUCTS

WRA-1 Schematic, changes, cabinet Misc. 16-7

NATIONAL CO-OPERATIVES INC.

R-546 Schematic, socket, trimmers, cabinet Misc. 16-8

NATIONAL UNION RADIO CORP.

G-613 Schematic, notes 16-1  
 Parts list, alignment, dial data, battery data, notes 16-2  
 G-615 Schematic, notes 16-3  
 Parts list, dial data, alignment 16-4

NOBLITT SPARKS INDUSTRIES

552AN, 552N, 555, 555A Schematic 16-1  
 Chassis, socket, trimmers, alignment, notes 16-2  
 Cabinets, miscellaneous servicing notes 16-3  
 Parts list, pushbutton data, dial data 16-4  
 665 Schematic 16-5  
 Record Changer, General Instrument Model 205 RCD.CH. 15-5  
 Cabinet, miscellaneous servicing notes, dial data 16-6  
 Alignment, chassis, socket, trimmers 16-7

NORTHERN RADIO COMPANY

N605-E Schematic, notes, cabinet 16-1  
 Clarified schematics 16-2  
 Alignment, socket, trimmers 16-3  
 Dial data, voltage, sensitivity, selectivity, notes 16-4

OLYMPIC RADIO & TELEVISION, INC.

MODEL		PAGE
6A-606	Schematic, socket, trimmers, alignment, battery data, notes	16-1
	Alignment, battery notes, parts list	16-2
6B-606	Schematic, socket, trimmers, alignment, battery data, notes	16-3
	Alignment, battery notes, parts list	16-4
7-526	Schematic, socket, trimmers, alignment, battery data, notes	16-5
	Alignment, battery notes, parts list	16-6
<u>PACKARD BELL CO.</u>		
5DA	Schematic	16-1
	Cabinet, voltage, socket, trimmers, alignment, miscellaneous servicing notes	16-2
568	Schematic	16-3
	Cabinet, voltage, socket, trimmers, alignment, miscellaneous servicing notes	16-4
<u>PHILCO CORP.</u>		
CR-2, Code 121	Schematic, gain data	16-1
	Socket, trimmers, chassis, alignment	16-2
	Cabinet, dial data, voltage and resistance	16-3
CR-4, Code 121	Schematic, gain data	16-4
	Socket, trimmers, chassis, alignment	16-6
	Dial data, permeability tuner, control unit, voltage and resistance	16-7
	Assembly	16-8
CR-6, Code 121	Schematic, gain data	16-5
	Socket, trimmers, chassis, alignment	16-6
	Dial data, permeability tuner, control unit, voltage and resistance	16-7
	Assembly	16-8
46-200, Code 125	Schematic, gain data	16-9
	Socket, trimmers, chassis, alignment	16-10
	Dial data, voltage and resistance, cabinet	16-11
46-1203, Code 125	Schematic, gain data	16-12
	Record Changer, Philco 46-1226	15-45
	Socket, trimmers, chassis, alignment	16-13
	Dial data, cabinet, voltage and resistance	16-14

PHILLIPS PETROLEUM CO.

(WOOLAROC)  
 3-1AX, 3-2AX Schematic, voltage 16-1  
 Alignment, socket, trimmers, dial data, gain data 16-2

PILOT RADIO CORP.

T-411-U Schematic, socket, trimmers, notes 16-1  
 Clarified schematics 16-2  
 Alignment, socket, trimmers 16-3  
 T-521 Schematic, voltage, socket, trimmers, notes 16-4  
 Clarified schematics 16-5  
 Alignment, antenna notes, dial data 16-6

THE PURE OIL CO., U.S.A.

(PURITAN)  
 5D15WG-5015, 5D25WG-5025 Schematic, coil data, voltage, socket, trimmers 16-1  
 Alignment, trimmers, dial data, parts list 16-2

PURITAN

See PURE OIL CO., U.S.A.

R.C.A. MFG. CO.

RC-474D, Chassis See Model X60  
 RC-507U, Chassis See Model Q121  
 RC-529A, Chassis See Model QB13  
 RC-585, Chassis See Model Q36  
 RC-606, Chassis See Model 67AV1  
 RC-608, Chassis See Model 68R1  
 RC-612, Chassis See Model QB13  
 RC-1017A, RC-1017B, Chassis See Model 62-1

R.C.A. MFG. CO. (Cont'd)		PAGE
MODEL		
RC-1034, Chassis	See Model 61-8	
RC-1044, Chassis	See Model Q103	
RC-1044B, Chassis	See Model Q103X	
RC-1047, Chassis	See Model 54B5	
Q36, Chassis RC-585	Schematic, voltage, notes	16-1
	Clarified schematics	16-2
	Alignment, wiring data	16-4
	Alignment, socket, trimmers, dial data, notes	16-5
	Cabinet, panel controls, miscellaneous servicing notes	16-6
	Parts list	16-7
Q103, Q103-2, Q103A, Q103A-2, Chassis RC-1044; Q103X, Q103X-2, Q103AX, Q103AX-2, Chassis RC-1044B	Schematic, gain data, coil data, notes	16-8
	Socket, trimmers, alignment	16-11
	Dials, miscellaneous servicing data	16-12
	Lead dress notes, cabinets, dial data, parts list	16-13
Q103, Q103-2, Q103A, Q103A-2, Q103X, Q103X-2, Q103AX, Q103AX-2, Q121, Chassis RC-507U	Clarified schematics	16-9
	Schematic, voltage, lead dress notes, miscellaneous notes	16-14
	Clarified schematics	16-15
	Alignment, socket, trimmers, wiring data, dial data	16-16
	Cabinet, control panel, dials, miscellaneous servicing notes	16-17
	Power supply data, loudspeaker and cable connections, parts list	16-18
QB13, Chassis RC-529A, RC-612	Schematic, gain data, notes	16-19
	Clarified schematics	16-20
	Alignment, socket, trimmers, dial data, coil and band switch data, lead dress notes	16-23
	Cabinet, Control panels, dials, miscellaneous servicing data	16-24
	Parts list	16-7
X60, Chassis RC-474D	Schematic, voltage, sensitivity	16-25
	Clarified schematics	16-26
	Cabinet, pushbutton data, socket, trimmers, alignment, dial data	16-27
54B5, Chassis RC-1047	Schematic, gain data, voltage, socket, trimmers, alignment, lead dress notes	16-28
	Miscellaneous servicing notes, chassis	16-29
	Cabinet, parts list	16-30
61-8, 61-9, Chassis RC-1034	Schematic, gain data, voltage, socket, trimmers, alignment, dial data	16-31
	Cabinets, lead dress notes, parts list	16-32
62-1, Chassis RC-1017A, RC-1017B	Schematic, gain data, voltage	16-33
	Record Changer, R.C.A. Model 960260-2	RCD.CH.15-17
	Cabinet, socket, trimmers, alignment, dial data, controls	16-34
67AV1, 67V1, Chassis RC-606	Schematic, gain data, voltage, coil data	16-35
	Record Changer, R.C.A. Model 960260-1	RCD.CH.15-17
	Clarified schematics	16-36
	Socket, trimmers, alignment, speaker connections, antenna data, dial data	16-37
	Cabinet, lead dress notes, controls, chassis	16-38
	Dials, parts list	16-39
68R1, 68R2, 68R3, 68R4, Chassis RC-608	Schematic, gain data, voltage	16-40
	Clarified schematics	16-41
	Socket, trimmers, alignment	16-42
	Cabinets, dial data, chassis, lead dress notes, miscellaneous servicing notes	16-43
	Dials, parts list	16-39
85TB	Schematic, coil data	16-44
	Clarified schematics	16-45
	Socket, trimmers, alignment, cabinet, voltage	16-46
	Parts list, miscellaneous servicing data	16-47
515	Schematic, gain data, voltage, cabinet, notes	16-48

R.C.A. MFG. CO. (Cont'd)		PAGE
MODEL		
515 (Cont'd)	Clarified schematics	16-49
	Socket, trimmers, alignment, dial data, parts list, lead dress notes	16-50
<u>RADIO AND TELEVISION INC.</u>		
D-6876, SF-6810, T-4000, T-4000-1/2	Schematic, resistance, voltage, notes	16-1
	Record Changer, Farnsworth Model P-51	RCD.CH.15-1
	Clarified schematics	16-2
	Switch data, coil data, I-F transformer data, socket, trimmers, notes	16-3
	Alignment, oscillograms	16-4
	Alignment, parts list	16-5
<u>RADIONIC EQUIPMENT CO.</u>		
14B	Schematic, cabinet	16-1
240T	Schematic, cabinet	16-2
<u>RADIO WIRE TELEVISION</u>		
BP-12	Schematic, battery data	16-1
	Battery data, operating data	16-2
FA-15	Schematic	16-3
J51P	Schematic, cabinet, power supply notes	16-4
MC-11	Schematic, voltage	16-5
	Socket, trimmers, alignment	16-6
<u>REGAL ELECTRONICS CORP.</u>		
800, 801	Schematic	16-1
900	Schematic, voltage	16-2
	Clarified schematics	16-3
1049	Schematic, voltage	16-2
	Clarified schematics	16-4
<u>HEMLER CO., LTD.</u>		
5100	Schematic, notes	Misc.16-9
<u>REXEL MERCHANDISE COMPANY</u>		
L-266	Schematic, voltage, socket, trimmers, alignment, notes, battery data	16-1
	Alignment, battery data, parts list	16-2
L-266-A	Schematic, voltage, socket, trimmers, alignment, notes, battery data	16-3
	Alignment, battery data, parts list	16-4
L-266-U	Schematic, voltage, socket, trimmers, alignment, notes, battery data	16-5
	Alignment, battery data, parts list	16-6
<u>RYAN SALES COMPANY</u>		
C5TS3	Schematic, notes	16-1
	Socket, trimmers, alignment, voltage, notes	16-2
<u>SCOTT RADIO LABORATORIES, INC..</u>		
Imperial, All Wave 800-B6	Schematic	16-1
	Partial schematic, parts list, attenuator, notes	16-2
<u>SEARS ROEBUCK &amp; CO.</u>		
7020, Ch. 101.807; 7021, Ch. 101.807A; 7054, Ch.101.808	Schematic, voltage, dial data, alignment	16-1
	Chassis, socket, trimmers, notes	16-2
	Parts list	16-3
	See Model 7020	
	Schematic, voltage, dial data, notes	16-4
7080, Ch. 101.809; 7100, Ch. 101.811	Alignment	16-1
	Socket, trimmers, chassis	16-5
	Parts list	16-8
7100	See Model 7080	
7165, Ch. 101.823; Ch. 101.823-1; 7166, Ch. 101.823A, Ch. 101.823-1A	Schematic, voltage	16-6
	Socket, trimmers, chassis	16-7
	Alignment, miscellaneous servicing notes	16-8

**SENTINEL  
TRUETONE**

SENTINEL RADIO CORP.

MODEL		PAGE
L-284I, L-284NA, L-28NI, L-284NR, L-284W	Schematic, voltage Alignment, socket, trimmers, chassis	16-8 16-9 16-10
IU284GA	Parts list, notes	16-1
IU285P	See Model 284GA	
IU293CT	See Model 285P	
247	See Model 293CT Schematic, voltage, socket, trimmers, chassis	16-1 16-2
276P	Alignment, battery data, notes Parts list Schematic, voltage, notes Alignment, socket, trimmers, chassis, battery data	16-2 16-10 16-5 16-4
284GA, IU284GA	Battery data, parts list, notes Schematic, cabinet, voltage, notes	16-5 16-6
285P, IU285P	Alignment, socket, trimmers, chassis	16-7 16-11
286P, 286PR	Parts list Schematic, voltage	16-19 16-14
293CT, IU293CT	Alignment, socket, trimmers, chassis Parts list, cabinet, battery data	16-15 16-16 16-17
510	Schematic, voltage Record changer, General Instrument 205 RCD.CH.	15-17 16-18 16-19
427	Alignment, socket, trimmers, chassis	16-20
447	Parts list, notes Schematic	16-18 16-19

SETCHELL-CARLSON, INC.

427	Schematic	16-1
447	Schematic, socket, trimmers, cabinet, notes	16-2

SIGNAL ELECTRONICS, INC.

341T	Schematic, dial data, socket, alignment	Misc. 16*10
------	--	-------------

SILVERTONE

See SEARS ROEBUCK CO.

SONORA RADIO & TELEVISION CORP.

A-11, Chassis A	Schematic	16-1
RBMU-176	Schematic, alignment	16-2
RGMF-212, RGMF-230	Schematic, socket, trimmers, alignment, notes	16-3 16-4
RK-215, RKRU-215	Schematic, notes Alignment	16-2 16-5
RQ-222, RQU-222	Schematic, socket, trimmers, alignment	16-5
RYMU-224	Schematic, battery notes, alignment, socket, trimmers	16-6
WA, WAU	Schematic, socket, trimmers, tuning data	16-7 16-4
WGF, WGFU	Alignment Schematic, socket, trimmers, alignment, antenna notes	16-4 16-8

SPARKS-WITHINGTON CO.

5-26, 5-26PS, 5-26X	Schematic, dial data, voltage Alignment, socket, trimmers	16-1 16-2
6F1	Schematic, dial data, notes Alignment, socket, trimmers, sensitivity, notes	16-3 16-4 16-5
6FID	Voltage Schematic, notes	16-6 16-5
6F2D	Voltage Alignment, socket, trimmers Roto-selector notes, dial data, miscellaneous servicing notes	16-7 16-8 16-9
6-26, 6-26PA	Schematic Alignment, socket, trimmers, dial data, notes Tuner notes, tuning panel, voltage, chassis, notes	16-10 16-11 16-12 16-13
	Schematic, dummy antenna Clarified schematics	16-14
	Alignment, socket, trimmers, voltage	16-14

SPARTON

See SPARKS-WITHINGTON CO.

SPIEGEL, INC.

MODEL		PAGE
T-2625	Schematic Clarified schematics	16-1 16-2
831	Alignment, socket, trimmers, miscellaneous servicing notes	16-3
	Schematic, voltage Clarified schematics	16-5 16-6
5020	Chassis, socket, trimmers, alignment, pushbutton data	16-7
	Schematic, socket, trimmers, alignment, notes	16-4
	Battery data	16-3

STEWART WARNER CORP.

9010A	Schematic, audio oscillation notes, voltage, dial data, gain data	16-1,2
	Clarified schematics	16-3
	Clarified schematics	16-4
	Clarified schematics	16-5
	Alignment	16-6
	Alignment, socket, trimmers, coil data, switch data	16-7
	Parts list	16-8
9013-A	Schematic, switch data, coil data	16-9
	Clarified schematics	16-10
	Parts list, gain data, dial data	16-11
	Alignment, socket, trimmers	16-12
	Voltage	16-8

STROMBERG CARLSON CO.

1105	Schematic, socket, trimmers, voltage, gain	16-1
	Wiring diagram, changes, notes	16-2
	Alignment, parts list, notes	16-3
1110	Schematic, voltage, gain Clarified schematics	16-4 16-5
	Wiring diagram, notes	16-6
	Alignment, socket, trimmers, dial data, parts data, RF adjustments	16-7
1135	Schematic, notes, gain data	16-9, 10
	Wiring diagram	16-8
	Voltage, socket, trimmers	16-16
	Alignment, RF adjustment	16-17
	RF adjustment, socket, trimmers, parts list, dial data	16-18
	Dial data, parts list	16-19
1135A	Schematic	16-11, 12
	Clarified schematics	16-13
	Clarified schematics	16-14
	Clarified schematics	16-15

TELECHRON, INC.

Musalarm 8H59	See Model 8H59 Schematic, voltage, sockets, notes	16-1
	Cabinet, alignment, dial data, trimmers, miscellaneous servicing notes	16-2
	Parts list, clock servicing data	16-3
	Clock movement assembly, parts list	16-4

TELECOIN CORP.

MSTS4	Schematic, socket, trimmers, voltage	16-1
	Cabinet, alignment, notes	16-2

TELETONE RADIO CORP.

Dynamite 135, Dynamite, Series H 138, Series N	See Model 135, Series H Schematic	Misc. 16-11
	Schematic	Misc. 16-11

TRANSVISION INC.

7 Inch Kit	Schematic	16-1,2
	Cabinet, circuit functions	16-3
	Circuit functions	16-4

TRAVLER RADIO CORP.

5003, 5004, 5005, 5006	Schematic, socket, trimmers, alignment	16-1
5019	Schematic, socket, trimmers, alignment, battery data	16-2
5030, 5031	Schematic, socket, trimmers, alignment	16-3

TRUETONE

See WESTERN AUTO SUPPLY CO.

UN MOTORS  
AERO

UNITED MOTORS SERVICE

MODEL		PAGE
R-1227, R-1228, R-1229	Schematic, voltage, socket, trimmers, chassis	16-1
	Parts list, dial data, coil data, alignment, cabinets	16-2
R-1408, R-1409	Schematic, voltage, socket, trimmers, chassis, dial data, coil data, battery data	16-3
	Alignment, parts list, cabinet	16-4
980690 Revised, 980733, Buick	Schematic, cabinets	16-5
	Voltage, socket, trimmers, transformer data, coil data	16-6
	Pushbutton data, parts list, tuner, alignment	16-7
980733	See Model 980690 Revised	
982399, Oldsmobile	Schematic, voltage, tuner	16-8
	Pushbutton data, cabinet, parts list	16-9
984170, Pontiac	Voltage, socket, trimmers, alignment	16-10
	Schematic, voltage, pushbutton data	16-11
	Voltage, dial data, power pack layout, socket, trimmers, alignment	16-12

U.S. TELEVISION MFG. CO.

5-16M	Schematic	16-1
	Voltage, alignment, socket, trimmers	16-2
5-36MPA	Schematic	16-1
	Voltage, alignment, socket, trimmers	16-2

VIEWTONE TELEVISION & RADIO CORP.

VP100, VP100A, VP101A	Schematic, socket, trimmers	16-1,2
	Miscellaneous servicing note, operation data	16-3
	Antenna notes, alignment	16-4

WARWICK MFG. CO.

C110	Schematic, socket, trimmers, alignment	16-1
	Record Changer, Milwaukee 10700	RCD.CH.15-1
11305	Schematic, socket, trimmers, alignment	16-2

WATTERSON RADIO MFG. CO.

4782	Schematic, battery data, alignment	16-1
4790	Schematic, antenna data, alignment	16-2

WESTERN AUTO SUPPLY CO.

D2616	Schematic, voltage, selectivity, sensitivity	16-1
	Alignment, socket, trimmers, dial data, pushbutton data	16-2
	Parts list	16-3
D2619	Schematic, voltage, socket, notes	16-4
	Parts list, dial data	16-3
	Alignment, trimmers, sensitivity, selectivity	16-5
D2624 Early, D2630	Schematic, coil data, selectivity, sensitivity	16-6
D2624 Late	Schematic, coil data, selectivity, sensitivity	16-7
D2624 Early, Late, D2630	Clarified schematics	16-8
	Socket, trimmers, alignment, voltage, dial data, notes	16-9
	Parts list	16-10
D2630	See Models D2624 Early	
D2644	Schematic, notes	16-11
	Alignment, socket, trimmers	16-10
D2645	Schematic, voltage, socket, trimmers, coil data	16-12
	Clarified schematics	16-13
	Alignment, trimmers, dial data, parts list, selectivity, sensitivity	16-14

WESTINGHOUSE ELECTRIC CORP.

H-113, H-114, H-116, H-117, H-119	Schematic, notes	16-1,2
	Clarified schematics	16-3
	Parts layout	16-5
	Alignment, socket, trimmers, dial data, notes	16-6
	Parts list, pushbutton data, cabinets	16-7
H-133	Schematic, voltage, dial data, socket, trimmers, cabinet, notes	16-8

WESTINGHOUSE ELECTRIC CORP. (Cont'd)

MODEL		PAGE
H-133 (Cont'd)	Alignment, parts list, chassis	16-10
H-148	Schematic, voltage, chassis, socket, trimmers, dial data, cabinet	16-9
	Alignment, parts list	16-10

WOOLAROC

See PHILLIPS PETROLEUM

ZENITH RADIO CORP.

4C54, Chassis	See Model 4K040	
4K040, 4K040G, Chassis 4C54	Schematic, voltage, gain, coil data	16-1
	Clarified schematics	16-2
	Alignment, socket, trimmers, dial data, parts list	16-3
5C40, 5C40Z, Chassis	See Model 5G003	
5C40ZZ, Chassis	See Model 5G003ZZ	
5C80, Chassis	See Model 5MX080	
5G003, Chassis 5G003Z, Chassis 5C40Z	Schematic, voltage, gain, coil data	16-4
	Alignment, socket, trimmers, dial data, parts list	16-6
5G003ZZ, Chassis 5C40ZZ	Schematic, voltage, gain, coil data	16-5
	Alignment, socket, trimmers, dial data, parts list	16-6
5MX080, Chassis 5C80, Crosley	Schematic, voltage, gain, notes	16-7
	Alignment, socket, trimmers, chassis, core and coil replacement notes	16-8
	Installation notes, parts list	16-9
6C41, Chassis	See Model 6G004Y	
6C50, Chassis	See Model 6G038	
6C83, Chassis	See Model 6MW083	
6G004Y, Chassis 6C41	Schematic, voltage, gain, coil data	16-10
	Clarified schematics	16-11
	Alignment, socket, trimmers, dial data, parts list	16-12
6G038, Chassis 6C50	Schematic, voltage, gain, coil data	16-13
	Clarified schematics	16-14
	Alignment, socket, trimmers, dial data, parts list	16-15
6MW083, Chassis 6C83, Willy's	Schematic, voltage, gain, notes	16-16
	Installation, pushbutton data	16-17
	Alignment, socket, trimmers, chassis, core and coil replacement notes	16-18
	Parts list	16-19
	See Model 8ML692	
8B03, Chassis	Schematic, notes	16-20
8ML692, Chassis 8B03, Lincoln-Zephyr	Installation data, muting circuit note	16-21
	Interference notes, alignment, socket, trimmers	16-22
	Alignment part 2, trimmers, voltage	16-23
	Parts list	16-24

INDEX TO RECORD CHANGERS

ADMIRAL CORP.

RC170, RC170A	Operation, change cycle	RCD.CH.16-1
	Differences	RCD.CH.16-2
	Adjustments	RCD.CH.16-3
	Pickup schematic, bottom view	RCD.CH.16-4
	Exploded view of top	RCD.CH.16-5
	Parts list	RCD.CH.16-6
	Service and repair	RCD.CH.16-7

AERO METAL PRODUCTS

46-A	Top view, operating instructions	RCD.CH.16-1
	Bottom and top view, change cycle	RCD.CH.16-2
	Exploded views of pickup and clutch	RCD.CH.16-3
	Service and parts list	RCD.CH.16-4

