

Most - Often - Needed

1949

RADIO
DIAGRAMS

and Servicing Information

Compiled by

M. N. BEITMAN

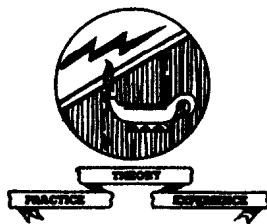

SUPREME PUBLICATIONS
CHICAGO

New 1948 TELEVISION Manual

INCLUDES EVERY POPULAR TELEVISION RECEIVER

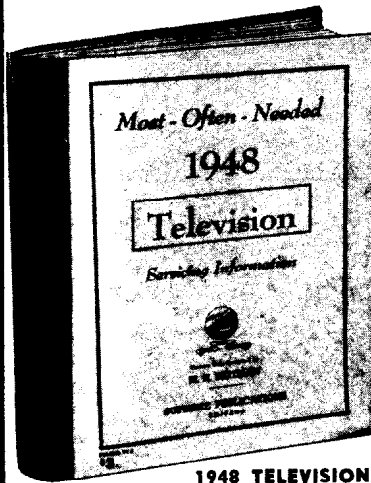

1948 TELEVISION
Contains material on all popular television sets, of Admiral, Belmont Radio, DuMont, Farnsworth, General Electric, Hallcrafters, Motorola, Philco, R.C.A., Sonora, Stromberg-Carlson, and others. Gives description of circuits, many pages of test patterns, response curves, oscilloscope waveforms, alignment tables, service hints, many diagrams in the form of giant double-spread blueprints, test points, voltage charts, etc. Large size: 8½x11 in., manual style binding, flexible covers, priced at only **\$3.00**

In this giant volume of television factory data, you have everything you need to repair every modern television set. For only \$3, total price, you get complete service and alignment material on all popular T-V sets. You receive easy-to-understand explanations of circuits, 144 pages of alignment procedure, test patterns, T-V antenna data, response curves, oscilloscope waveforms, voltage charts, adjustment hints, many diagrams on mammoth 11x17-inch blueprints, everything to bring you up to date and make you an expert in television repairs.



Compiled by M. N. Beltman, radio engineer, teacher, author & serviceman.

FIND-FIX ALL TELEVISION FAULTS

Use this new practical "cyclopedia" of television servicing as your guide to quick fault finding and repair of any modern television set. Eliminates guesswork—tells you just where to look and what to do. Cuts hour-wasting jobs to pleasant moments. Use test patterns for quick adjustment, or look up probable cause of trouble in the pages of hints after simply observing fault of picture on screen. No equipment needed with these tests. Or use your volt-meter and compare values with many voltage charts included. Observe waveforms similar to hundreds illustrated using test points suggested and in a flash locate what used-to-be a hard-to-find fault. This manual will give you the know-how of a television expert and will repay for itself with time saved on the first T-V job.

BIGGEST BARGAIN T-V TRAINING

For 15 years, radio servicemen expected and received remarkable values in Supreme Publications service manuals. The new 1948 Television Manual is a virtual treatise on practical television repairs. By normal standards, such a large manual packed as it is with practical data, illustrations, diagrams, charts, photographs, and expensive extra-large blueprints, should sell for \$10—but as another Supreme special value, it is priced to servicemen at only \$3, postpaid. Only a publisher who sold over one million of various radio manuals can offer such bargain prices based on tremendous volume-sales. Read about this new T-V manual at left. Find out about other radio manuals listed below.

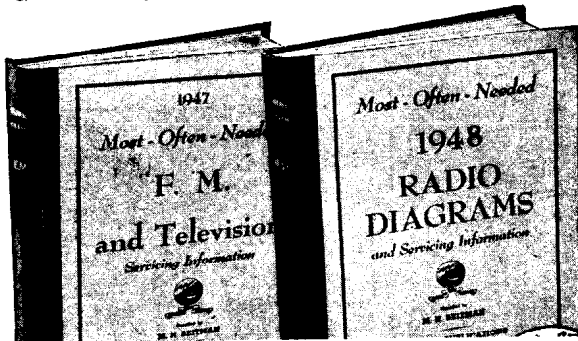

F.M. and Television

Use this extra-large manual of factory instructions for trouble-shooting, repairing, and alignment of all popular 1947 F.M. and Television sets. Covers every popular make, including F.M. tuners, AM-FM combinations, and all types of television receivers. Detail circuit diagrams, theory of operation, test hints, alignment data, including both meter and oscilloscope methods. Use this recent Supreme manual to save time and money on your very next F.M. job. Data presented on 192 large pages, 8½x11 inches. Sturdy, manual-style binding. Tremendous value. Price postpaid, only..... **\$2.**

1948 Radio Diagrams

Be prepared to repair quickly all new 1948 radio receivers. In this big single volume you have clearly-printed, large schematics, needed alignment data, replacement parts lists, voltage values, and information on stage gain, location of trimmers, and dial stringing, for almost all recently released sets. Makes toughest jobs amazingly easy. Find all faults in a jiffy. A worthy companion to the 7 previous volumes used by over 120,000 shrewd radio servicemen. Will pay for itself on first job. Manual covers models of 42 different manufacturers. Giant size 8½x11 inches. 192 pages+index. Manual-style binding. Price only.... **\$2.**

RADIO DIAGRAMS AND F.M. SERVICE MANUALS

You can speed-up and simplify radio repairs with Supreme Publications Manuals. Service radios faster, better, easier, save time and money, use these most-often-needed diagram manuals to get ahead, earn more per hour. For the remarkable bargain price (only \$2 for most volumes) you are assured of having in your shop and on the job, needed diagrams and other essential repair data on 4 out of 5 sets you will ever service. Every popular radio of all makes from old-timers to new 1948 sets, including F.M. and Television, is covered. Clearly printed circuits, parts lists, alignment data, and helpful service hints are the facts you need to improve your servicing ability. Let these manuals furnish you with diagrams for 80% of all sets. There is no need to spend large sums for bulky, space-wasting manuals, or to buy additional drawings every few weeks; be wise, use SUPREME Manuals to get the most in diagrams and service data for the smallest cost. Select manuals at left and below.



1947 1946 1942 1941 1940 1939 1926-1938
MOST-OFTEN-NEEDED RADIO DIAGRAMS
Each manual has between 192 and 208 pages of diagrams, alignment data, voltage values, and service hints, **\$2**
DIAGRAMS
240 Pages
manual style, large size, 8½x11". Price, each **\$2.50**

Supreme Publications

Sold by all Leading Radio Jobbers

Copyrighted 1949, Supreme Publications, Chicago

All rights reserved, including the right to reproduce or quote the contents of this book, or any portion thereof, in any form.

MANUAL OF 1949 MOST-OFTEN-NEEDED RADIO DIAGRAMS

INDEX

Admiral Radio Corp.		Buick		Fada Radio & Elect.	
4D1	7	980797	141	790	34
4D11	7	980798	141	795	33
4D12	7				
4D13	7	Chrysler		Garod Radio Corp.	
5F1	6	802	82	5A3	35
5F11	6	C4608	82	5A4	35
5F12	6				
6C1	8	Crosley Corp.		General-Electric	
6C11	8	9-101	19	14	39
6R11	9-11	9-102	21	60	40
		9-103	18	62	40
Airline		9-104W	18	102, 102W	39
see Montgomery W.		9-113	20	107, 107W	39
		9-114W	20	113	42
Arvin		9-118W	21	114, 114W	39
152T	72	9-119	23	115, 115W	39
153T	72	9-120W	23	118	41
160T	76	9-209	22	119M, 119W	41
161T	76	9-209L	24	150	44
RE-232	76	9-212M	22	210	43
RE-233	72	9-212ML	24	211	43
240P	73	9-213B	24	212	43
241P	73	9-214M	25	356	45
242T	78	9-214ML	25	357	45
RE-242	77	9-302	26	376	36-38
243T	78	88TA, 88TC	17	377	36-38
RE-243	73			378	36-38
244P	73	Delco			
RE-244	73	see United Motors		General Motors	
RE-248	75			see United Motors	
250P	75	De Wald Radio Mfg.		Goodrich (B.F.) Co.	
RE-251	78	B-400	27	92505	46
RE-253	74	A-500	27	92506	46
RE-254	73	A-501	27		
RE-255	73	A-502	27	Hallicrafters Co.	
RE-256	73	A-503	27	S-40A	47-48
RE-259	73				
280TFM	74	Emerson Radio		Hoffman Radio Corp.	
281TFM	74	557	28	115	49
547, 547A	77	559	29	129	50
2410P	73	565	28	B503	49
		570	30	B508	50
		573	32	B509	50
Belmont Radio Corp.		574	30	B510	50
A-5D118	12	577	31	B513	49
6D121	13	580	30		
5240	14	583	32	Howard Radio Co.	
		120012B	31	481-A	51
Bendix Radio		120039B	32	481-B, -C, -M	51
55X4	16	120048B	28		
65P4	15	120059	29		
		120064	30		

MANUAL OF 1949 MOST-OFTEN-NEEDED RADIO DIAGRAMS

<p>Mantola</p> <p>92505 46</p> <p>92506 46</p> <p>Meissner Mfg. Co.</p> <p>8C 52</p> <p>Montgomery Ward Co.</p> <p>74BR-1501B 55</p> <p>74BR-1502B 55</p> <p>84BR-1065A 54</p> <p>84BR-1501, -2 55</p> <p>84BR-1503D 56</p> <p>84BR-1504D 56</p> <p>84BR-1507B 57</p> <p>84BR-1508B 57</p> <p>84BR-2003C 58</p> <p>84GCB-1062A 53</p> <p>84WG-2704D 59</p> <p>84WG-2712A 60</p> <p>84WG-2714G 61</p> <p>84WG-2721C 62</p> <p>Motorola, Inc.</p> <p>OE2 64</p> <p>PC2 64</p> <p>5A7, 5A7A 63</p> <p>SR6 64</p> <p>8A 64</p> <p>BK8, BK8X 64</p> <p>CR8 66</p> <p>CT8 64</p> <p>FDS 64</p> <p>8FDT 64</p> <p>8GMT 64</p> <p>HN8 64</p> <p>KR8 64</p> <p>NH8 64</p> <p>OE8 64</p> <p>PC8 64</p> <p>SR8 64</p> <p>58A11 65</p> <p>58A12 65</p> <p>58L11 67</p> <p>58R11 to -R16 68</p> <p>HS-58 69</p> <p>HS-62, HS-62A 63</p> <p>67X11 to -X13 69</p> <p>68L11 70</p> <p>HS-114 67</p> <p>HS-116 68</p> <p>HS-119 70</p> <p>HS-158 65</p> <p>408 71</p> <p>708 71</p>	<p>Noblitt-Sparks</p> <p>152T 72</p> <p>153T 72</p> <p>160T 76</p> <p>161T 76</p> <p>RE-232 76</p> <p>RE-233 72</p> <p>240P 73</p> <p>241P 73</p> <p>242T 78</p> <p>RE-242 77</p> <p>243T 78</p> <p>RE-243 73</p> <p>244P 73</p> <p>RE-244 73</p> <p>RE-248 75</p> <p>250P 75</p> <p>RE-251 78</p> <p>RE-253 74</p> <p>RE-254 73</p> <p>RE-255 73</p> <p>RE-256 73</p> <p>RE-259 73</p> <p>280TFM 74</p> <p>281TFM 74</p> <p>547, 547A 77</p> <p>2410P 73</p> <p>Oldsmobile</p> <p>982455 142</p> <p>Olympic Radio</p> <p>7-622 79</p> <p>7-638 79</p> <p>Packard-Bell Co.</p> <p>771, 771X 80</p> <p>Philco Corp.</p> <p>CR-2 81</p> <p>CR-4 83</p> <p>CR-6 83</p> <p>UN6-100 81</p> <p>48-300 84</p> <p>48-461 85</p> <p>48-472, -1 87</p> <p>48-1262 86</p> <p>48-1282 86</p> <p>49-500, -1 88</p> <p>49-501 88</p> <p>49-503 88</p> <p>49-504 88</p> <p>49-505 88</p> <p>49-601 89</p> <p>49-602 89</p>	<p>Philco, Continued</p> <p>49-900E, -I 90</p> <p>49-901 91</p> <p>49-1401 92</p> <p>802 82</p> <p>C4608 82</p> <p>Pontiac</p> <p>984247 144</p> <p>R.C.A. Victor</p> <p>2S7ED 95</p> <p>8BX5 93</p> <p>8BX6 94</p> <p>8F43 95</p> <p>8R71 97-98</p> <p>8R72 97-98</p> <p>8R74 97-98</p> <p>8R75 97-98</p> <p>8R76 97-98</p> <p>8V7 96</p> <p>8V90, 8V91 102</p> <p>8V112 108</p> <p>8V151 99-100</p> <p>8X53 104</p> <p>8X521 103</p> <p>8X522 103</p> <p>8X541 105</p> <p>8X542 105</p> <p>8X547 105</p> <p>8X681 107</p> <p>8X682 107</p> <p>75X11 106</p> <p>75X12 106</p> <p>77U 101</p> <p>77V1 96</p> <p>RK-121C 99-100</p> <p>RS-123D 99-100</p> <p>RP-178 111-118</p> <p>RC-613A 109-110</p> <p>RC-615 96</p> <p>RC-616 108</p> <p>RC-616A, -H 102</p> <p>RC-618, -A 102</p> <p>710V2 109-110</p> <p>RC-1037B 95</p> <p>RC-1040C 94</p> <p>RC-1050 106</p> <p>RC-1059 93</p> <p>RC-1060, -A 97-98</p> <p>RC-1061 107</p> <p>RC-1064 104</p> <p>RC-1065, -A 105</p> <p>RC-1066, -A 103</p> <p>Record Changer 111</p>
--	--	---

MANUAL OF 1949 MOST-OFTEN-NEEDED RADIO DIAGRAMS

Sears, Roebuck & Co.	
7080	122
8020	120
8070	122
8080	119
8083	122
8084	122
8086	124
8101	122
8102, -A, -B	124
8107A	121
8108, -A	121
8153, -A	123
101.809	122
101.814	124
101.817	122
101.851	121
101.852	119
109.635	123
132.841	120

Sentinel Radio	
1U-314E, -I	126
1U-314W	126
314E, -I, -W	126
323K	127
329-I, -R, -W	125

Silvertone
see Sears, Roebuck

Sonora Radio	
100	129
101	129
102	128

Sparks-Withington
see Sparton

Sparton	
6B9	131
8L9	132-133
121	132-133
1030, -A	130
1058	132-133
1059	132-133
1060	132-133
1061	132-133
1064	132-133
1072	132-133

Stewart-Warner	
C51T1	134
C51T2	134
A61P1	135
A61P2	135
A61P3	135
B61T1	136
B61T2	136
9036-A, -B, -C	135
9045-A, -B	134
9046-A, -B	136

Stromberg-Carlson	
1200	137
1202	137
1204	138-139

Truetone
see Western Auto

United Motors	
R-705	143
R-1244	140
R-1245	140
R-1246	140

United Motors, Cont.	
980797	141
980798	141
982455	142
984247	144

Western Auto	
D1836	145
D1846	146
D2815	147
D4832	148

Westinghouse Elect.	
H-164	149
H-165	150
H-166, -A	149
H-167	149
H-185	151
H-188	152
H-190	153
H-191, -A	153
H-195	151
H-202	154
H-204	154

Zenith Radio Corp.	
5D810	155
5D811	155
5E01	155
5E02	155
6D815	156
6E03	157
6E05	156
6R880	157
7E02	158-159
7E22	160
7H822	158-159
7R887	160

New F.M. and TELEVISION Manual



Use this giant manual of factory data for trouble-shooting, repairing, and alignment of any recent F.M. and TELEVISION set. Circuit diagrams, explanations, service hints, tests. Covers every popular make, including F.M. tuners, AM-FM combinations, and all types of television receivers.

192 large pages, 8½x11" plus index. Sturdy manual style binding. **\$2.**
Special price, only.....

Simplified Radio Servicing by COMPARISON Method



Repair radios in minutes instead of hours. Revolutionary different COMPARISON technique permits you to do expert work on all radio sets. Most repairs can be made without test equipment or with only a volt-ohmmeter. Many simple, point-to-point, cross-reference, circuit suggestions locate the faults instantly. Plan copyrighted. Covers every radio set—new and old models. This new servicing technique presented in handy manual form, size 8½x11 inches, 72 pages. Over 1,000 practical service hints. 26 large, trouble-shooting blueprints. Charts for circuit analysis. 114 tests using a 5c resistor. Developed by M. N. Beitman. New 1948 edition. Net Price **\$1.50**

ADVANCED RADIO SERVICING

Use these 30 lectures in giant manual form to learn advanced methods, hints, tips, and suggestions. Take advantage of M. N. Beitman's 19 years of radio experience as presented in these easy-to-follow, illustrated lectures. Every servicing topic of importance, including F.M. and television. 30 lectures, large size: 8½ x 11 inches, only **\$3.**

MANUAL OF 1949 MOST-OFTEN-NEEDED RADIO DIAGRAMS

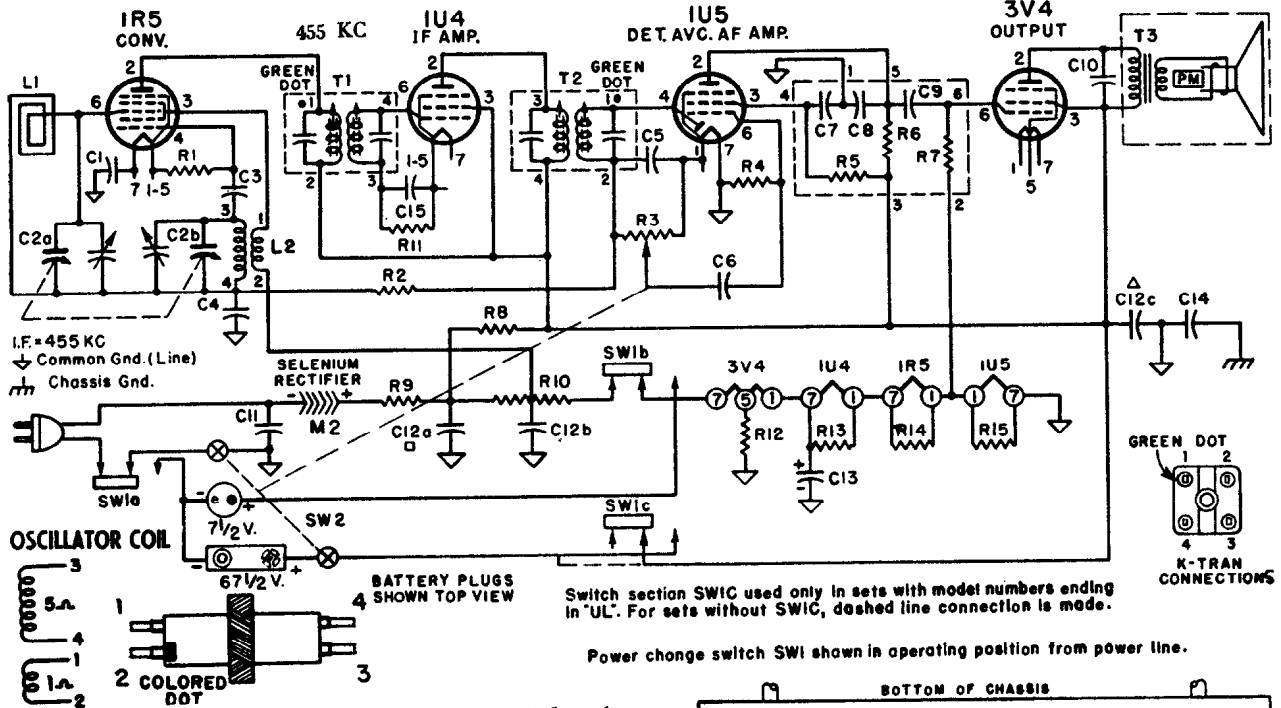

- Voltage readings taken between tube socket terminals and B minus (metal shell of electrolytic condenser).
- Dial set to low frequency, no signal, and volume control minimum.
- Measurements made from 117 volts AC line. If measured from DC line, voltages may be slightly lower.
- Voltage readings taken with a vacuum tube voltmeter. Socket terminals marked with an asterisk * indicate much lower voltage or zero voltage if measured with a 1000 ohm-per-volt meter.
- If measurements are made on battery operation, tube filament and B plus voltages will vary with the condition of the batteries. These voltages will equal the terminal voltage of the A or B battery less the voltage drop through components.

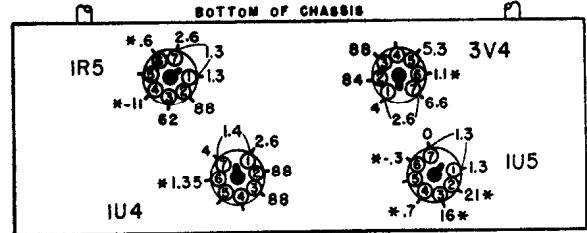

* If taken with a 1000 ohm-per-volt meter, readings will be lower or zero.

RESISTORS

Symbol	Description	Part No.
R1	100,000 Ohms, 1/4 Watt	60B 27-104
R2	3.3 Megohms, 1/4 Watt	60B 27-335
R3	1 Megohm, Volume Control and On-Off Switch	75B 1-21
R4	10 Megohms, 1/4 Watt	60B 27-106
R5	4.7 Megohms	
R6	1 Megohm	
R7	2.2 Megohms	
R8	2,700 Ohms, 1 Watt	60B 14-272
R9	47 Ohms, 1 Watt	60B 14-470
R10	2,400 Ohms, 2.5 Watt (Tapped Caddock)	61A 5-3
R11	10 Megohms, 1/4 Watt (R11 not used in early production)	60B 27-106
R12	2,200 Ohms, 1/4 Watt	60B 26-222
R13	390 Ohms, 1/4 Watt	60B 26-391
R14	160 Ohms, 1/4 Watt	60B 26-181
R15	120 Ohms, 1/4 Watt	60B 26-121

CONDENSERS

C1	.25 mfd., 200 Volts, Paper	64B 1-28
C2a	Gang, 420 mfd. (max)	68B 14
C2b	Gang, 126 mfd. (max)	
C3	100 mfd., Ceramic	65B 6-3
C4	.01 mfd., 400 Volts, Paper	64B 1-25
C5	100 mfd., Ceramic	65B 6-3
C6	.001 mfd., Ceramic (tolerance - 0%, + 20%)	65B 6-41
C7	.005 mfd., Ceramic	
C8	100 mfd., Ceramic	
C9	.005 mfd., Ceramic	
C10	.001 mfd., Ceramic (tolerance - 0%, + 20%)	65B 6-41
C11	.05 mfd., 400 Volts, Paper	64B 1-22
C12a	30 mfd., 150 Volts	
C12b	20 mfd., 150 Volts	Elect. 67C 7-1
C12c	20 mfd., 150 Volts	
C13	100 mfd., 25 Volts, Elect.	67A 4-6
C14	.1 mfd., 200 Volts, Paper	64B 1-30
C15	.001 mfd., Ceramic (tolerance - 0%, + 20%)	65B 6-41

(C15 not used in early production)

Admiral

CHASSIS 5F1
 MODELS 5F11, 5F12

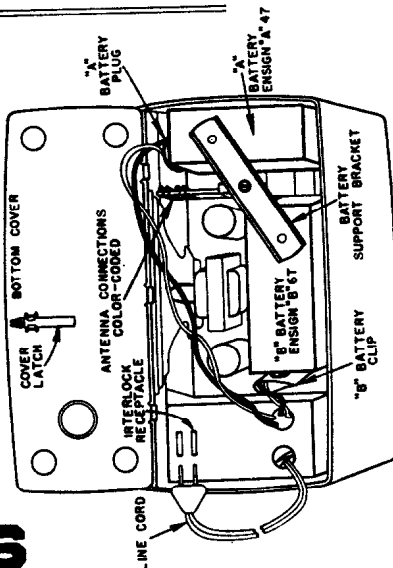

TUBE AND TRIMMER LOCATION

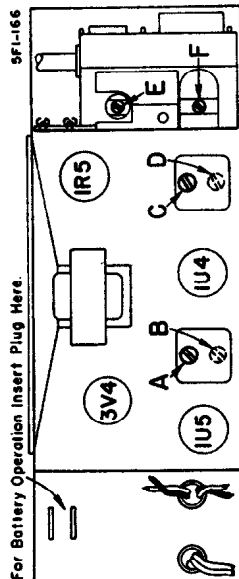

REPLACEMENT OF BATTERIES

Use replacement A and B batteries of the following types:
 A Battery: Ensign A47 or equivalent.
 B Battery: Ensign B67, Burgess XX45, Eveready 467 or equivalent.

† C7, C8, R5, R8, R7 are contained in a multiple-unit component called a couplette (part number 63A4-3). Although a defective section of the couplette can sometimes be replaced by individual components, we recommend replacing the entire couplette.

Note that numerals 1, 2, 3, 4, 5, and 6 shown at schematic connections, correspond to couplette lead numbers printed on body of couplette directly above the leads.

MANUAL OF 1949 MOST-OFTEN-NEEDED RADIO DIAGRAMS

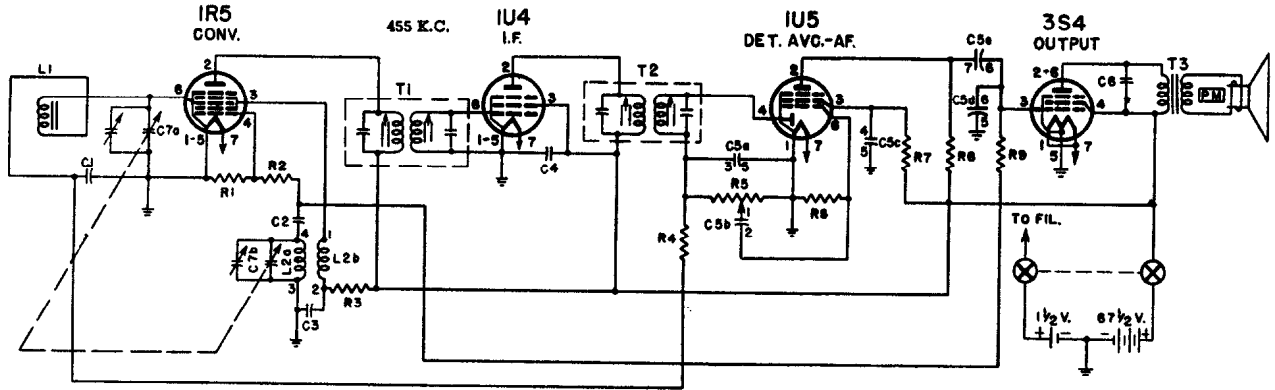

OSCILLATOR COIL

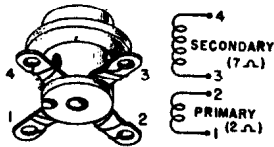

NOTE: C5a, C5b, C5c, C5d and C5e are contained in a single unit (Bulplate). The numbers next to the C5 condenser plates on the schematic correspond to the lead numbers as shown on the drawing of the "BULPLATE" (see inset). If sections of this unit should open or short it will not be necessary to replace the entire Bulplate. Replace the bad section with a condenser of proper value. Note that leads 5 and 6 are common to more than one section.

BULPLATE

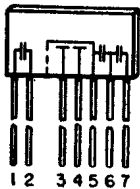

NOTE: Some microphonic howling may occur on strong signals if the volume control is turned beyond the overload point. The following changes have been made in late production because some "B" batteries, with high internal resistance, may cause squealing at normal volume levels.

- (a) Condenser C3 (.005 mfd. 600 volt, oscillator plate bypass) has been replaced with a .1 mfd. 200 volt condenser.
- (b) Condenser C6 (.002 mfd. 600 volt, 3S4 late bypass) has been returned to the screen grid (pin 4) rather than to ground.
- (c) The speaker leads have been reversed, the red lead has been

connected to the plate and the blue lead to the screen of the 3S4.

- (d) For early production chassis which do not have the above changes, the same results can usually be secured by adding 4 mfd. 200 volt electrolytic condenser from B+ to chassis. Be sure the condenser is connected in the circuit on the set side of the on-off switch. Do not connect it to the battery side of the switch or the inherent leakage of the condenser will appreciably shorten the "B" battery life.

RESISTORS

Symbol	Part No.	Value	Power	Part No.
R1	60B 3-473	47,000 Ohms	1/4 Watt	
R2	60B 2-561	560 Ohms	1/4 Watt	
R3	60B 3-103	10,000 Ohms	1/4 Watt	
R4	60B 3-335	3.3 Megohms	1/4 Watt	
R5	75B 1-22	1 Megohm	Volume Control and Switch SW1	
R6	60B 3-106	10 Megohms	1/4 Watt	
R7	60B 3-475	4.7 Megohms	1/4 Watt	
R8	60B 3-105	1 Megohm	1/4 Watt	
R9	60B 3-225	2.2 Megohms	1/4 Watt	

COILS, TRANSFORMERS, Etc.

Symbol	Part No.	Description
L1	69B 38	Antenna, Loop
L2a } L2b }	69A 39-1	Coil, Oscillator
T1	72B 28-1	Transformer, 1st I.F.
T2	72B 28-1	Transformer, 2nd I.F.
T3	98A 13	Transformer, Output
	78C 33	Speaker (3 1/2" PM) & Output Transformer
SW1	Part of R5	Switch, On-Off

CONDENSERS

Symbol	Part No.	Value	Material
C1	64B 1-10	.01 mfd.	600 Volts, Paper
C2	65B 6-3	.0001 mfd.	Ceramic
C3	64B 1-30	.1 mfd.	200 Volts, Paper
C4	64B 1-28	.25 mfd.	200 Volts, Paper
C5a	63A 2	150 mmfd.	Ceramic
C5b	63A 2	.002 mfd.	Ceramic
C5c	63A 2	.006 mfd.	Ceramic
C5d	63A 2	100 mmfd.	Ceramic
C5e	63A 2	.005 mfd.	Ceramic
C6	64B 1-14	.002 mfd.	600 Volts, Paper
C7a	68B 13	0 to 354	mmfd., Gang
C7b	68B 13	0 to 107.2	mmfd., Gang

Admiral

**CHASSIS 4D1
MODELS 4D11, 4D12, 4D13**

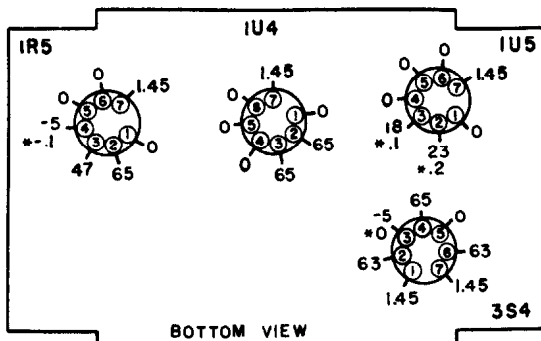
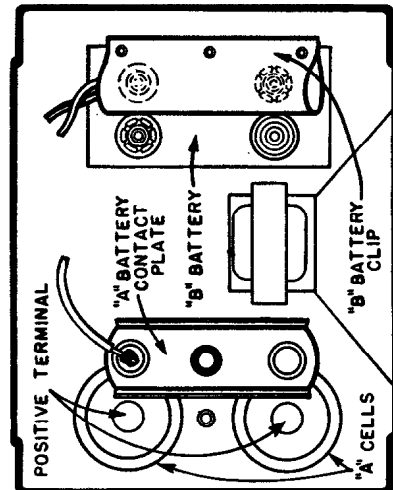

VOLTAGE DATA

- Readings made between point indicated and chassis.
- Measured using a fresh set of batteries.
- Turned to low frequency end, no signal.
- Voltages measured with Vacuum-Tube Voltmeter.
- A second voltage reading (marked with an asterisk *) indicates readings made with a 1000 ohm-per-volt meter when use of this instrument would result in appreciably lower readings.

MANUAL OF 1949 MOST-OFTEN-NEEDED RADIO DIAGRAMS

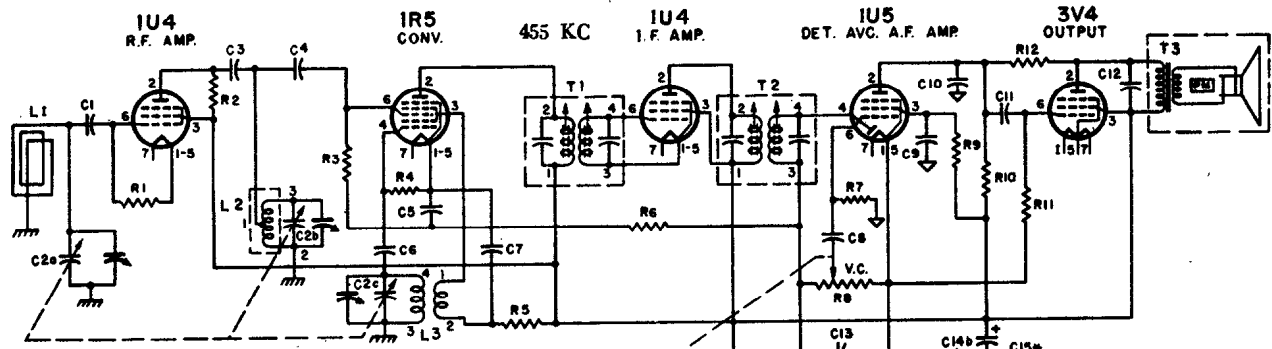

I.F. = 455 K.C.
 ↓ Common Line Con. (C-)
 ⏏ Chassis Gnd.

Power change switch SW1 shown in operating position from power line.

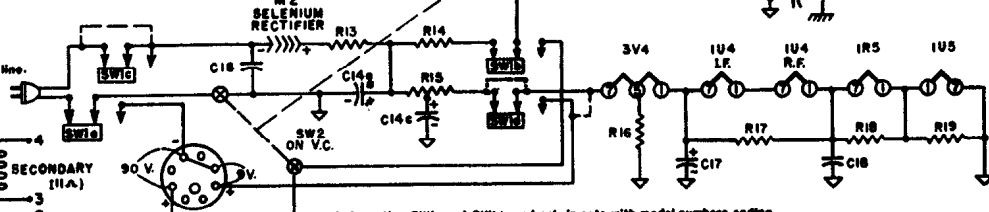
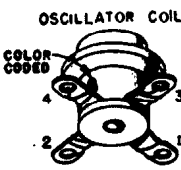

Switch section SW1c and SW1d used only in sets with model numbers ending in "UL". For sets without SW1c and SW1d, dashed line connection is made.

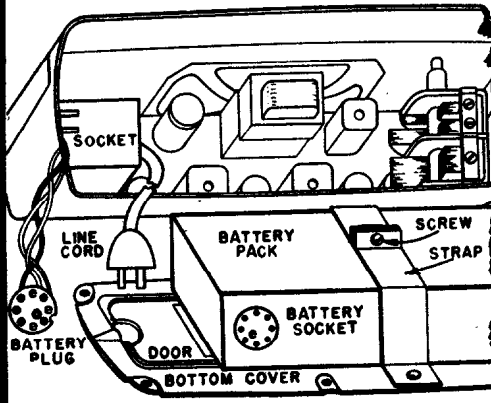

Symbol	Description	Part No.
R1	2.2 Megohms, 1/4 Watt	60B 27-225
R2	27,000 Ohms, 1/4 Watt	60B 28-273
R3	1 Megohm, 1/4 Watt	60B 27-105
R4	100,000 Ohms, 1/4 Watt	60B 27-104
R5	8,200 Ohms, 1/4 Watt	60B 26-822
R6	3.3 Megohms, 1/4 Watt	60B 27-335
R7	10 Megohms, 1/4 Watt	60B 27-106
R8	1 Megohm, Volume Control and On-Off Switch	75B 1-26
R9	47 Megohms, 1/4 Watt	60B 27-475
R10	4.7 Megohms, 1/4 Watt	60B 27-474
R11	2.2 Megohms, 1/4 Watt	60B 27-225
R12	5.6 Megohms, 1/4 Watt	80B 26-565
R13	47 Ohms, 1 Watt	60B 14-470
R14	2,700 Ohms, 1 Watt	60B 14-272
R15	2,400 Ohms, 2.5 Watt Tapped Candohm	61A 5-3
R16	1,500 Ohms, 1/4 Watt	80B 26-152
R17	820 Ohms, 1/4 Watt	80B 26-821
R18	220 Ohms, 1/4 Watt	60B 26-221
R19	150 Ohms, 1/4 Watt	60B 26-151

Symbol	Description	Part No.
C1	250 mmfd., Ceramic	65B 6-5
C2a	Gang, 420.0 mmfd. (max.) Ant. Section	68B 10
C2b	Gang 193.8 mmfd. (max.) RF Section	68B 10
C2c	Gang, 90.0 mmfd. (max.)	65B 6-3
C3	100 mmfd., Ceramic	65B 6-3
C4	250 mmfd., Ceramic	65B 6-5
C5	100 mmfd., Ceramic	65B 6-3
C6	.05 mfd., 200 Volts, Paper	84B 1-32
C7	.001 mfd., Ceramic (tolerance -0%, +20%)	65B 6-41
C8	.005 mfd., 800 Volts, Paper	84B 1-12
C9	.05 mfd., 200 Volts, Paper	84B 1-32
C10	100 mmfd., Ceramic	65B 6-3
C11	.005 mfd., 600 Volts, Paper	84B 1-12
C12	.001 mfd., Ceramic (tolerance -0%, +20%)	65B 6-41
C13	250 mmfd., Ceramic	65B 6-5
C14a	30 mfd., 150 Volts	Elect. 67C 7-52
C14b	40 mfd., 150 Volts	
C14c	20 mfd., 150 Volts	
C15	.18 mfd., 200 Volts, Paper	64A 2-2
C16	.05 mfd., 400 Volts, Paper	64B 1-22
C17	100 mfd., 25 Volts, Elect.	67A 4-5
C18	.25 mfd., 200 Volts, Paper	64B 1-28

Note: In some sets, R5 was 10,000 Ohms; other sets used pair of 18,000 Ohm resistors in parallel.

Note: In sets with model numbers ending in "UL", C15 is .1 mfd., 400 V.

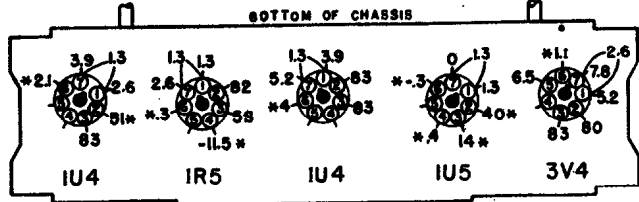

- * If taken with a 1000 ohm-per-volt meter, readings will be lower or zero.
- Voltage readings taken between tube socket terminals and B minus (metal shell of electrolytic condenser).
- Dial set to low frequency, no signal, and volume control minimum.
- Measurements made from 117 volts AC line. If measured from DC line, voltages may be slightly lower.
- Voltage readings taken with a vacuum tube voltmeter. Socket terminals marked with an asterisk * indicate much lower voltage or zero voltage if measured with a 1000 ohm-per-volt meter.
- If measurements are made on battery operation, tube filament and B plus voltages will vary with the condition of the batteries. These voltages will equal the terminal voltage of the A or B battery minus the voltage drop through components.

Admiral

CHASSIS 6C1
 MODEL 6C11

TUBE AND TRIMMER LOCATION

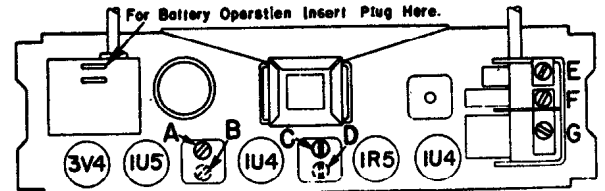

REPLACEMENT OF BATTERY PACK

Replace A-B battery pack with Ensign type AB50 pack, Ray-O-Vac AB994, General 60A-6F6-5, Burgess F6A60 or other equivalent.

To install a replacement battery pack, first remove the six screws that hold the metal bottom cover to the cabinet. (See illustration.) The battery pack is strapped to the bottom cover and will come out when the cover is removed. Pull out the battery plug, loosen the screw which holds the battery strap tight, and slide out the old battery pack.

Slip a new battery pack into place, tighten the screw which tightens the strap around the battery, plug in the battery plug and re-install the bottom cover.

MANUAL OF 1949 MOST-OFTEN-NEEDED RADIO DIAGRAMS

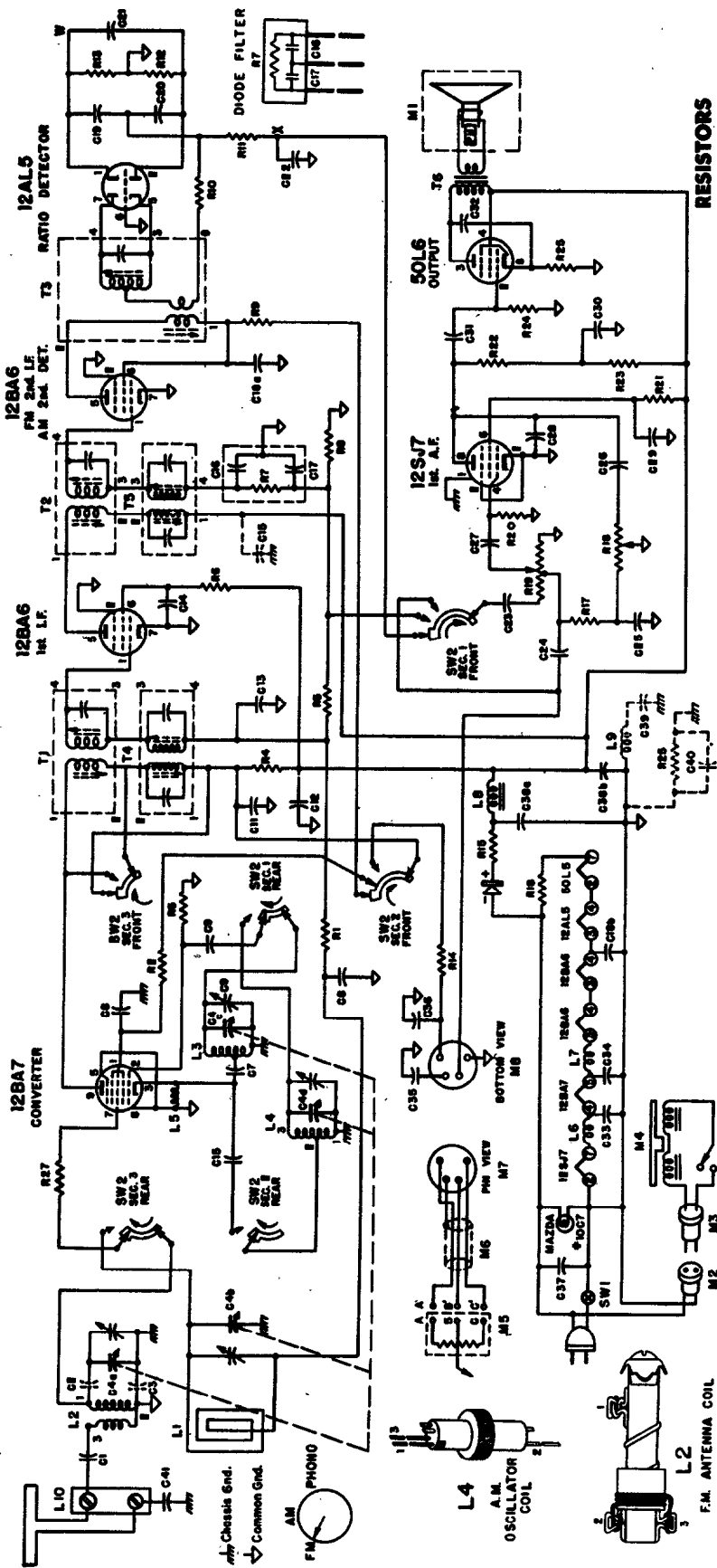

Symbol	Description	Part No.
R1	470,000 Ohms, 1/4 Watt	608 2-474
R2	1,000 Ohms, 1/4 Watt	608 2-102
R3	22,000 Ohms, 1/4 Watt	608 2-223
R4	470 Ohms, 1/4 Watt	608 2-471
R5	470,000 Ohms, 1/4 Watt	608 2-474
R6	1,000 Ohms, 1/4 Watt	608 2-102
R7	47,000 Ohms, 1/4 Watt	608 2-224
R8	220,000 Ohms, 1/4 Watt	608 2-102
R9	1,000 Ohms, 1/4 Watt	608 2-391
R10	390 Ohms, 1/4 Watt	608 2-273
R11	2,200 Ohms, 1/4 Watt	608 1-682
R12	6,800 Ohms, 1/4 Watt	608 1-682
R13	6,800 Ohms, 1/4 Watt	608 1-682
R14	100,000 Ohms, 1/4 Watt	608 2-104
R15	33 Ohms, 1 Watt	608 14-370
R16	47 Ohms, 1 Watt	608 2-273
R17	27 Ohms, 1/4 Watt	608 2-273
R18	2 Megohms Tone Control	758 1-12
R19	ON/OFF Switch SW2	758 2-12
R20	47 Megohms Volume Control	758 2-12
R21	1.5 Megohms, 1/4 Watt	608 3-475
R22	470,000 Ohms, 1/4 Watt	608 2-474
R23	470,000 Ohms, 1/4 Watt	608 2-474
R24	150 Ohms, 1/2 Watt	608 8-151
R25	150,000 Ohms, 1/2 Watt	608 2-154
R27	10 Ohms, 1/4 Watt	608 2-100

Symbol	Description	Part No.
C29	.1 mfd., 200 Volts, Paper	648 1-30
C30	.1 mfd., 200 Volts, Paper	648 1-30
C31	.01 mfd., 400 Volts, Paper	648 1-25
C32	.01 mfd., 400 Volts, Paper	648 1-25
C33	.0015 mfd. min., Ceramic	65A 14-2
C34	.0015 mfd. min., Ceramic	65A 14-2
C35	.01 mfd., 400 Volts, Paper	648 1-25
C36	.18 mfd., 200 Volts, Paper	648 2-2
C37	.05 mfd., 200 Volts, Paper	648 1-32
C38a	70 mfd., 150 Volts Elect.	67C 6-40
C38b	30 mfd., 150 Volts Elect.	67C 6-40
C39	.01 mfd., 200 Volts, Paper	648 1-30
C40	.0015 mfd. min., Ceramic	65A 10-3
C41	.0015 mfd. min., Ceramic	65A 14-2

Symbol	Description	Part No.
§C15	.005 mfd. min., Ceramic	65A 10-1
†C16	100 mmfd., Mica	65A 10-1
†C17	100 mmfd., Mica	65A 10-1
C18a	.004 mfd. min., Dual Ceramic	65A 17-1
C18b	.004 mfd. min., Dual Ceramic	65A 17-1
C19	100 mmfd., 5%, -00075 Temp. Coeff., Ceramic	608 6-7
C20	100 mmfd., 5%, -00075 Temp. Coeff., Ceramic	608 6-7
C21	4 mfd., 50 Volts, Elect.	65B 4-8
C22	.002 mfd., 600 Volts, Paper	648 1-14
C23	.001 mfd., Ceramic	65B 9-31
C24	500 mmfd., Ceramic	65B 9-24

Symbol	Description	Part No.
C1	200 mmfd., Ceramic	65B 9-15
†C2	.0015 mfd. min., Ceramic	65B 9-43
†C3	100 mmfd., Mica	65A 10-1
C4a	485 mmfd. (mark.), AM RF	A1B14
C4b	15 mmfd. (mark.), AM RF	65A 10-1
C4c	1425 mmfd. (mark.), AM Osc.	65A 10-1
C5	.01 mfd., 400 Volts, Paper	648 1-25
C6	3-12 mfd. Trimmer	65B 6-97
C7	50 mfd. min., Ceramic	65B 6-4
C8	.005 mfd. min., Ceramic	65A 10-1
C9	35 mmfd., 10% Zero Temp. Coeff., Ceramic	65B 9-31
C10	.005 mfd. min., Ceramic	65A 10-1
C11	.005 mfd. min., Ceramic	65A 10-1
C12	.005 mfd. min., Ceramic	65A 10-1
C13	.005 mfd. min., Ceramic	65A 10-1
C14	.01 mfd. min., Ceramic	65A 10-3

CONDENSERS

† Part of enclosed Diode Filter Unit 62A3-1. This unit consists of R7, C16, C17 (see Schematic). If a section of the unit becomes defective, it may be replaced with a component of proper value.

§ Used only in sets with model numbers ending in "UJ".

COILS, TRANSFORMERS, ETC.

Antenna Loop (AM).....608 73
 Coil RF (FM).....69A 68
 Coil Oscillator (AM).....69A 69
 Coil Oscillator (FM).....69A 20-3
 Choke Cathode RF.....AA 39-5
 Choke Heater RF.....73A 2-3
 Choke, Filter.....74A 15-2
 Coil If Trans.....608 73
 Approx. 5 turns (18") of #14 No. 22 hook-up wire wound on C39. Solder one end to inside foil lead of C39.

Admiral Model 6R11
 Alignment information on the next two pages.



MANUAL OF 1949 MOST-OFTEN-NEEDED RADIO DIAGRAMS

Admiral

MODEL 6R11

IMPORTANT PRELIMINARY ALIGNMENT STEPS

In FM alignment, it is essential that every step be followed. Especially important is picking the center of the IF curve (step 4 in the FM-IF alignment instructions). During this portion of the alignment it is necessary to tune the signal generator very carefully; it may necessitate having to estimate the dial readings to a tenth of a division.

Under normal operating conditions or use, misalignment of RF or IF circuits with age will be slight. Lack of sensitivity and poor tone quality may be due to causes other than alignment. Do not attempt to realign the receiver until all other possible causes have first been thoroughly investigated.

If complete alignment is necessary, it is essential that proper sequence be followed as tabulated in the alignment chart. However, if only the AM band or a portion

of the FM circuit are to be aligned, proceed from that point on the chart being sure to follow all remaining steps.

Adjustments made to FM-IF's at 10.7 MC, will require realignment of AM-IF slug adjustments.

Check pointer position. With tuning gang closed, the tip of the pointer clip should be over the 1/16" circular punch at the extreme left end of the dial background (see stringing diagram).

Use an isolation transformer if available, otherwise connect a .1 mfd. condenser in series with low side of signal generator and attach to B minus of chassis.

Be sure both the set and the signal generator are thoroughly warmed up before starting alignment.

FM I.F. AND RATIO DETECTOR ALIGNMENT

- Keep output indicator leads well separated from signal generator leads and chassis wiring.
- Band switch in FM position (fully to the left).
- While peaking IF's, keep reducing signal generator output so VTVM reading is approximately +1.5 volts DC with exception of Step #5.
- To avoid splitting the slotted head of iron core tuning slugs in the IF transformers, use an insulated alignment tool with a 1/8" wide screwdriver blade. Do not exert undue pressure as threads of slugs may strip.
- Speaker must be connected during alignment.
- FM antenna disconnected during alignment.

Before proceeding, be sure to follow all steps listed above, under "Important Preliminary Alignment Steps."

	Connect Signal Generator	Generator Frequency	Receiver Dial Setting	Output Indicator and Special Connections	Adjust as Follows (very carefully)
1	Thru .001 cond. to 2nd IF grid (pin #1 of 12BA6 2nd IF)	10.7 MC unmodulated.	Tuning gang wide open	Connect VTVM (DC probe) from point "W" to B minus ("Y"). (See Fig. 7.)	"A" (ratio detector primary) for maximum reading on VTVM.
2	**Thru .001 cond. to 1st IF grid (pin #1 of 12BA6 1st IF)	"	"	" "	Iron cores "B" and "C" (2nd IF trans.) for maximum reading on VTVM.
3	High side FM antenna terminal	"	"	" "	Iron cores "D" and "E" for maximum on VTVM. Re-adjust A, B, C, D, E, for maximum. (Keep reducing generator output to keep VTVM at 1.5 volts)
4	"	a. Reduce output of signal generator until VTVM reads exactly +1.5 volts DC. b. Tune generator frequency above 10.7 MC until VTVM reads exactly +1.0 volt. Note exact generator frequency. Extreme care in reading this is essential. c. Tune generator frequency below 10.7 MC until VTVM reads exactly +1.0 volt. Note exact generator frequency. Extreme care in reading this is essential. d. Add generator frequency in step c to generator frequency in step b and divide by 2. The result is the center frequency of the IF curve to be used in step 5. See example on next page. e. Tune generator frequency above and below 10.7 MC and note voltage reading on VTVM at different frequency points until you have a good impression of the shape of the selectivity curve. If you have two peaks as in Figures 5 or 6, note readings (voltage) of both peaks. If one peak is over 20% higher than the other one, it will be necessary to realign IF's. A selectivity curve that would require realignment is illustrated by Figure 6.			
5	"	Center of IF selectivity curve per step 4d above. See "EXAMPLE" on next page.	Tuning gang wide open	Connect VTVM (DC probe) from point "X" to B minus ("Y"). (See Fig. 7.)	Iron core "F" (ratio detector secondary) for zero voltage reading on VTVM. (The correct zero point is located between a positive and a negative maximum.)

If any adjustments were very far off, it is desirable to repeat steps 3, 4 and 5.

10

**Do not feed I.F. signal into converter grid as this will cause mis-alignment.

MANUAL OF 1949 MOST-OFTEN-NEEDED RADIO DIAGRAMS

Admiral

MODEL 6R11

SETTING SIGNAL GENERATOR TO CENTER OF I.F. SELECTIVITY CURVE

CAUTION: Due to the difficulty of setting a signal generator to the accuracy required by this operation, extreme care must be exercised in making each setting. Otherwise, improper alignment of the ratio detector and consequent audio distortion will result.

EXAMPLE: (See Figures 1 and 2)

Voltage reading in Step 4a is + 1.5 volts.

Generator frequency on low side of 10.7 MC for a reading of + 1 volt DC = 10.640 MC.

Generator frequency on high side of 10.7 MC for a reading of + 1 volt DC = 10.800 MC.

Center frequency is obtained by adding 10.640 and 10.800, then dividing by 2. For these readings it will be 10.72 MC.

Set generator frequency to 10.72 MC as this is center of selectivity curve as shown in Figure 2.

Note: Numerical vernier dial readings may be used instead of MC.

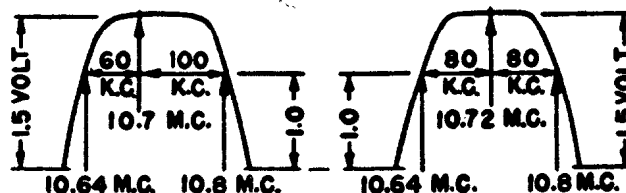

Fig. 1

Fig. 2

TYPICAL SELECTIVITY CURVES

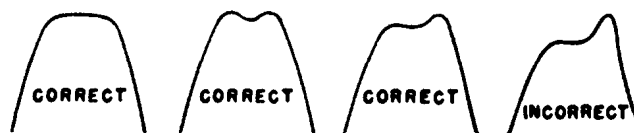

Fig. 3

Fig. 4

Fig. 5

Fig. 6

FM RF ALIGNMENT PROCEDURE

	Connect Signal Generator	Generator Frequency	Receiver Dial Setting	Output Indicator and Connections	Adjust as Follows
6	Thru 270 ohm carbon resistor to high side FM antenna terminal	109 MC† (unmodulated).	Tuning gang wide open	Connect VTVM (DC probe) from point "W" to ground.	*G for maximum VTVM reading.
7		102 MC† (unmodulated).	102 MC	"	*Tune in generator signal on receiver. Adjust H for max. VTVM reading.

* It is advisable to adjust generator output so VTVM readings do not exceed approximately + 1.5 V. DC after peaking.
 † If your signal generator does not reach this frequency, use harmonics as described in "FM Alignment Equipment."

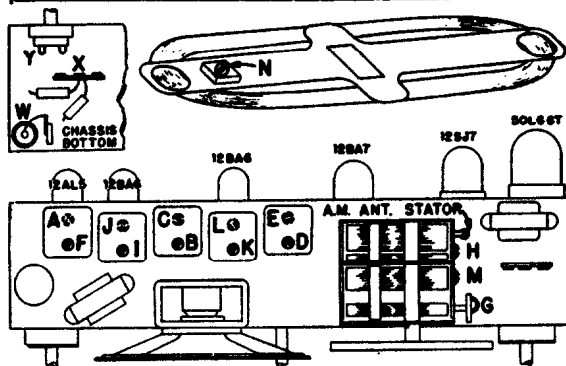
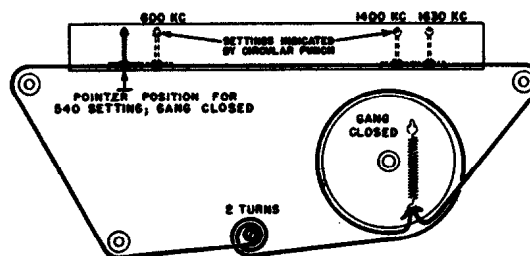

Fig. 7. Trimmer Location



With the gang fully closed, the tip of the pointer clip should be in line with the 1/16" circular punch at the extreme left end of the dial background.

Fig. 8. Dial Stringing and Pointer Setting

AM ALIGNMENT PROCEDURE

- Use regular output meter connected across speaker voice coil.
- Turn receiver Volume Control full on; Tone Control full treble.
- AM loop antenna must be connected and placed in the same relative position to the chassis as when in cabinet.
- Use lowest output setting of signal generator that gives a satisfactory reading on meter.

	Connect Signal Generator	Dummy Antenna Between Radio and Signal Generator	Signal Generator Frequency	Receiver Dial Setting	Adj. Trimmers in Following Order to Max.
Set Band Switch to Broadcast Position (center) and be sure to follow instructions under heading "Important Preliminary Alignment Steps." Loop antenna must be connected.					
1	Gang condenser antenna stator	.1 MFD	455 KC	Tuning gang wide open	I, J, K, L
2	AM Antenna Stator	Direct connection	1620 KC	Tuning gang wide open	M
Install chassis and AM loop in cabinet.					
3	Place generator lead close to loop of set to obtain adequate signal. No actual connection (signal by radiation).		1400 KC	Tune in signal	N

MANUAL OF 1949 MOST-OFTEN-NEEDED RADIO DIAGRAMS

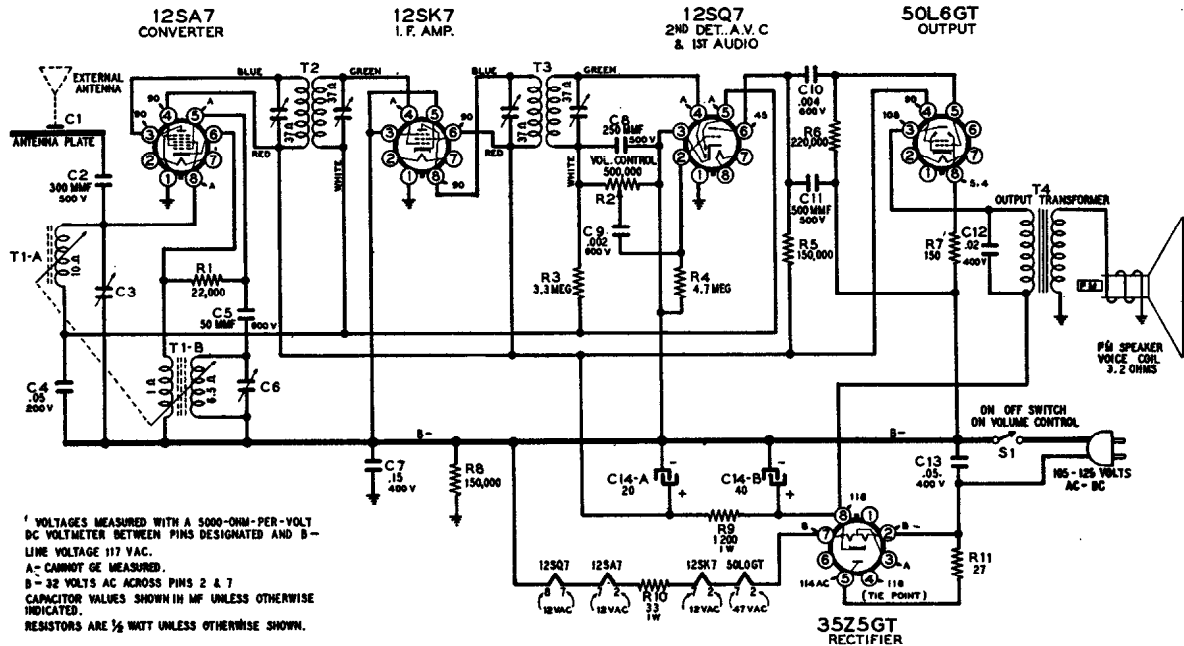

ALIGNMENT PROCEDURE

Volume control—Maximum all adjustments.

Connect B—of radio chassis (12SQ7-Pin 3) to ground post of signal generator through .1 Mfd. condenser.

SIGNAL GENERATOR			POSITION OF IRON CORES (Dial Setting)	ADJUST TRIMMERS TO MAXIMUM (in order shown)
Frequency Setting	Dummy Antenna	Connection to Radio		
455 Kc.	.1 MFD.	Connect to Metal Antenna Backplate	Iron Cores All the way out	Trimmers on output and input I. F. cans
1720 Kc.	.1 MFD.	Connect to Metal Antenna Backplate	Iron Cores All the way out	Osc. Trimmer (C6) (See voltage chart)
1720 Kc.	200 MMF.	Connect to Outside Antenna Clip	Iron Cores All the way out	Ant. Trimmer (C3) (See voltage chart)
1400 Kc.	200 MMF.	Connect to Outside Antenna Clip	Turn Dial to 1400 Kc.	Adjust position of antenna coil (See coil assembly view)
1720 Kc.	200 MMF.	Connect to Outside Antenna Clip	Turn Dial to 1720 Kc.	Adjust trimmer (C3) (See voltage chart)

NOTE "A"—The antenna coil assembly is made so that it is movable. When making the adjustment as given in the alignment procedure move the coil assembly very slowly. It can be moved by hand or by pivoting one edge of the blade of a screwdriver in the hole and engaging the blade in the gear teeth of the coil form.

NOTE "B"—After the antenna coil has been tracked at 1400 Kc. it is necessary to check the antenna trimmer (C3) adjustment again at 1720 Kc. If no appreciable change in trimmer adjustment is made the coil is in track. If the trimmer requires considerable change it will be necessary to again adjust the position of the antenna coil at 1400 Kc. These two adjustments should be tried several times until no change of trimmer adjustment is required at 1720 Kc.

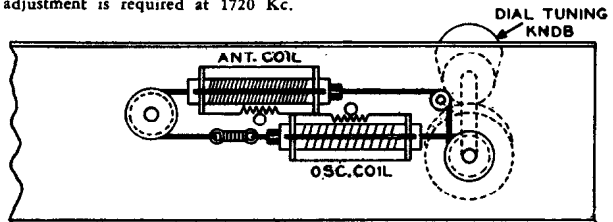
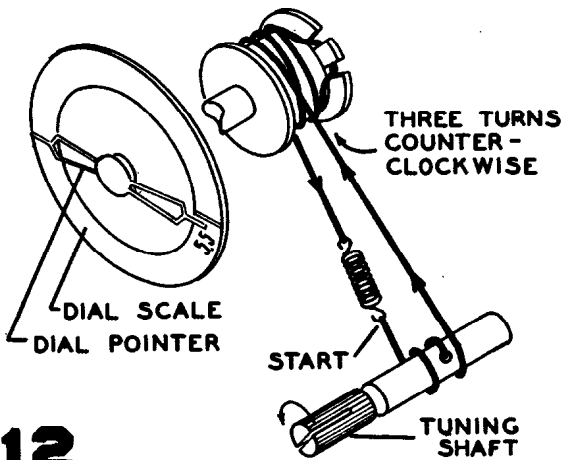

Coil Assembly View

Belmont Radio
MODEL A-5D118

MANUAL OF 1949 MOST-OFTEN-NEEDED RADIO DIAGRAMS

Belmont MODEL 6D121 SERIES A

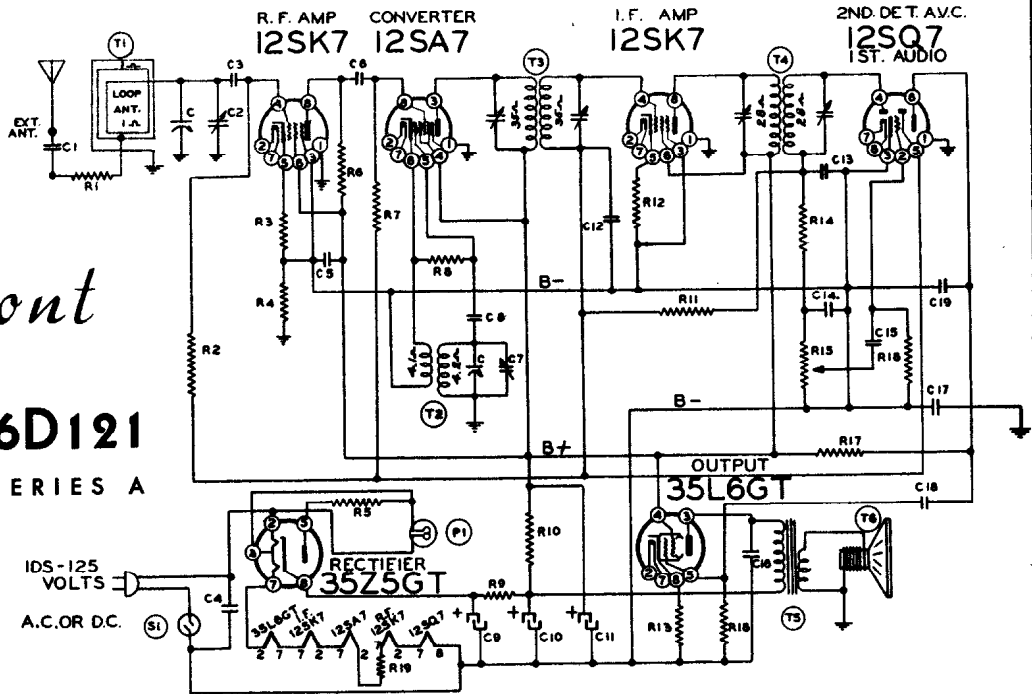

NOTE: On some sets slug tuned I.F.s are used instead of trimmer tuned I.F.s. 108-140H and 108-145 are trimmer tuned. B-13A-12023 and B-13B-12022 are slug tuned. The slug tuned I.F.s are tuned from the top and bottom (secondary

on top, primary on bottom).

Slug tuned I.F.s cannot be used to substitute trimmer tuned I.F.s but trimmer tuned I.F.s can be used to substitute slug tuned I.F.s.

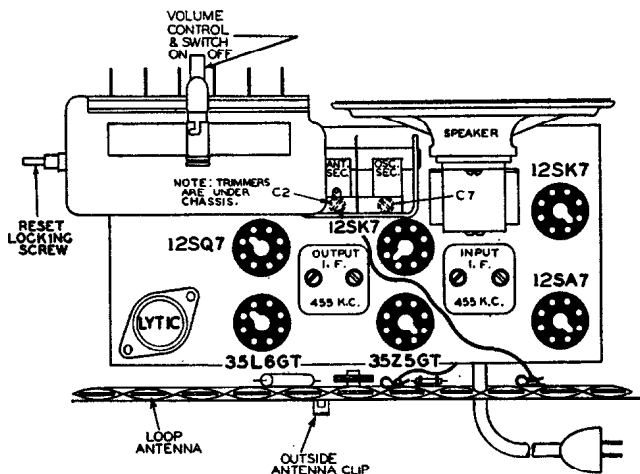

CHASSIS VIEW, SHOWING TUBE LOCATIONS
(See note above on I.F.s)

Part No.	Schematic Symbol	Description
----------	------------------	-------------

CONDENSERS		
C-8D-10953	C17	.15 MFD x 400 volts.
C-8D-10778	C1, C15	.002 x 600 volts, +40%, -15%
C-8F3-3	C3	.470 mmmfd. mica, ±20%
C-8D-10760	C4	.1 x 400 volts, +20%
C-8D-10775	C5	.25 x 200 volts, ±20%
C-8F3-8	C6, C8, C19	.001, mica, ±20%
11994 or A-8C-10077	C9, C10, C11	Electrolytic (for 50-60-cycle sets), 40 mfd. x 150 volts, 20 mfd. x 150 volts.
C-8D-10770	C12	.05 x 200 volts, ±20%
129161	C13, C14	Dual .0001, mica, ±10%
C-8D-10774	C16	.02 x 400 volts, ±20%
C-8D-10778	C18	.004 x 600 volts, ±20%

RESISTORS		
C-9B1-13	R1	1000 ohms, 1/2 watt, ±20%
C-9B1-31	R2	1 megohm, 1/2 watt, ±20%
C-9B1-50	R3	100 ohms, 1/2 watt, ±10%
C-9B1-26	R4	150,000 ohms, 1/2 watt, ±20%
C-9B1-42	R5	22 ohms, 1/2 watt, ±10%
C-9B1-70	R6	4700 ohms, 1/2 watt, ±10%
C-9B1-25	R7	100,000 ohms, 1/2 watt, ±20%
C-9B1-28	R8, R14	47,000 ohms, 1/2 watt, ±20%
C-9B2-53	R9	180 ohms, 1 watt, ±10%
C-9B2-63	R10	1200 ohms, 1 watt, ±10%
C-9B1-34	R11	3.3 megohms, 1/2 watt, ±10%
C-9B1-52	R12, R13	150 ohms, 1/2 watt, ±10%
C-9B1-27	R16	470,000 ohms, 1/2 watt, ±20%
C-9B1-35	R17	220,000 ohms, 1/2 watt, ±20%
C-9B1-35	R18	4.7 megohms, 1/2 watt, ±20%
C-9B2-44	R19	33 ohms, 1 watt, ±10%

ALIGNMENT PROCEDURE

- No aligning adjustments should be attempted until all other possible causes of trouble have been checked.
- Chassis must be removed from cabinet for proper alignment. Slight adjustments of the oscillator and antenna circuits can be made, without removing the chassis, through two holes provided on the bottom of the cabinet. The two adjustment screws can be reached with a long insulated screwdriver.
- It is important that during alignment the loop antenna

- be maintained at the same distance from the chassis as when the chassis is installed in the cabinet.
- Turn volume control to maximum for all adjustments.
- Connect ground post of signal generator to B- of radio through a 0.1 mfd. condenser.
- Connect dummy antenna value in series with generator output lead.
- Connect output meter across primary of output transformer.

Band	Signal Generator Frequency Setting	Dummy Antenna	Connection to Radio	Tuning Condenser Setting	Adjust for Maximum Output (see chassis view)
I.F.	455 Kc.	0.1 mfd.	Grid of 12SA7	Rotor full open (plates out of mesh)	4 trimmers on input and output I.F. transformers (See note)
Broadcast	1650 Kc.	0.1 mfd.	Grid of 12SA7	Rotor full open (plates out of mesh)	Oscillator trimmer C7 on bottom of radio
	1400 Kc.	None	See note A	Set dial at 1400 Kc.	Antenna trimmer C3 on bottom of radio

Note A: Lay output lead of generator in back of loop antenna. Turn up generator output. Loop antenna will pick up

MANUAL OF 1949 MOST-OFTEN-NEEDED RADIO DIAGRAMS

Belmont MODEL 5240

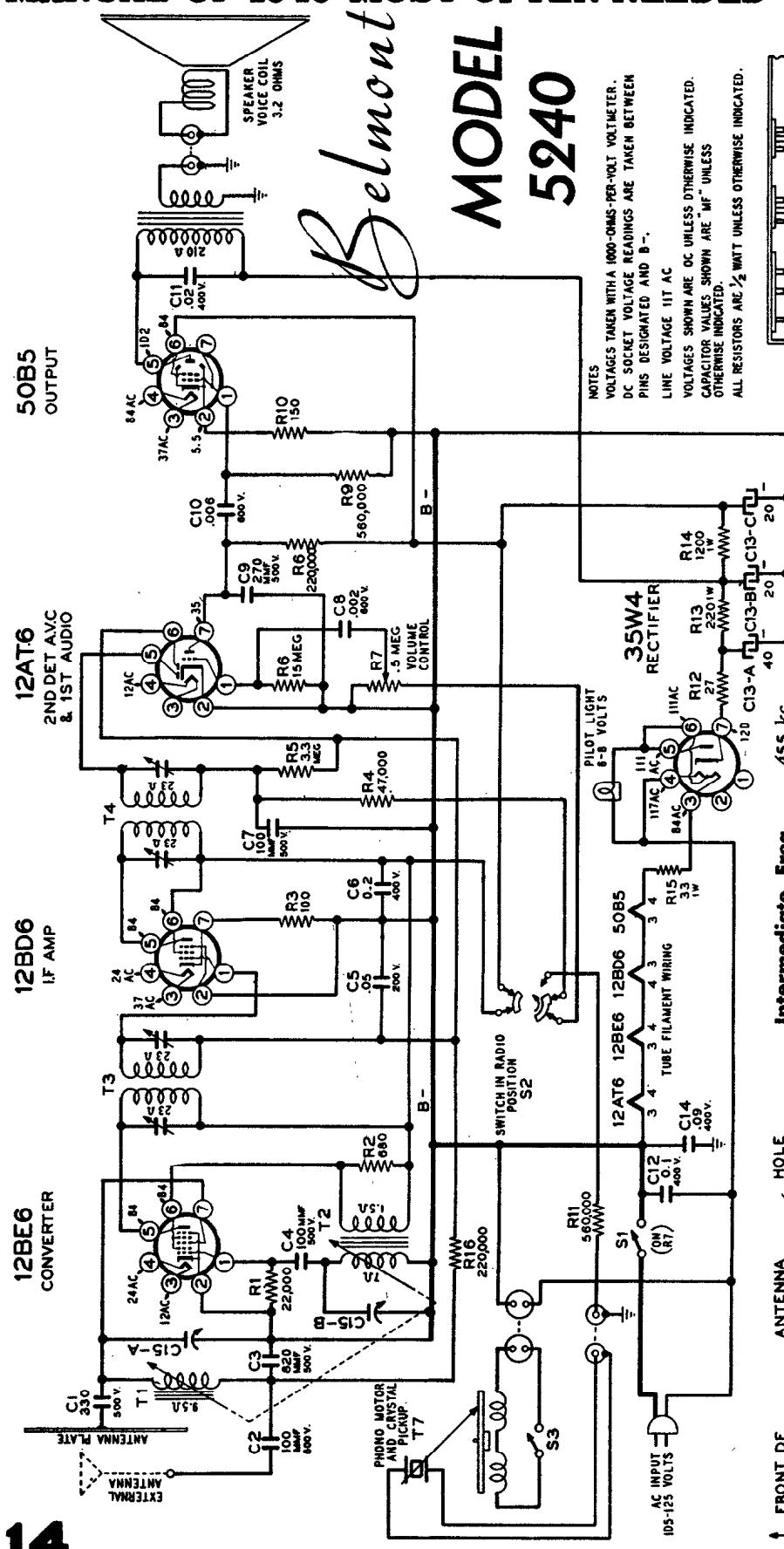

NOTES
 VOLTAGES TAKEN WITH A 1000-OHMS-PER-VOLT VOLTMETER.
 DC SOCKET VOLTAGE READINGS ARE TAKEN BETWEEN PINS DESIGNATED AND B-.
 LINE VOLTAGE 117 AC
 VOLTAGES SHOWN ARE DC UNLESS OTHERWISE INDICATED.
 CAPACITOR VALUES SHOWN ARE "MF" UNLESS OTHERWISE INDICATED.
 ALL RESISTORS ARE 1/2 WATT UNLESS OTHERWISE INDICATED.

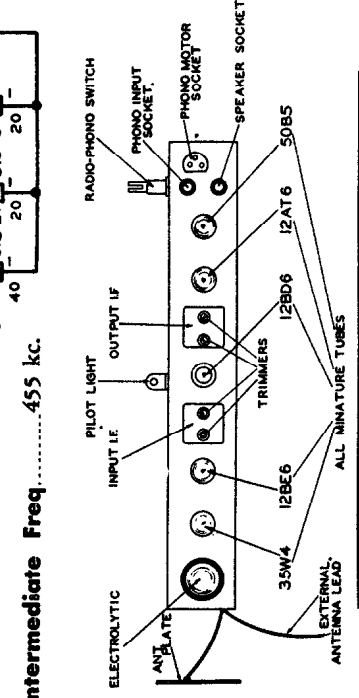
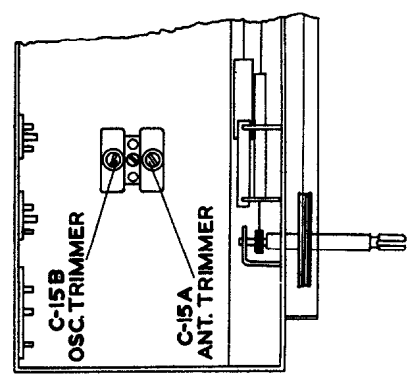

CHASSIS VIEW

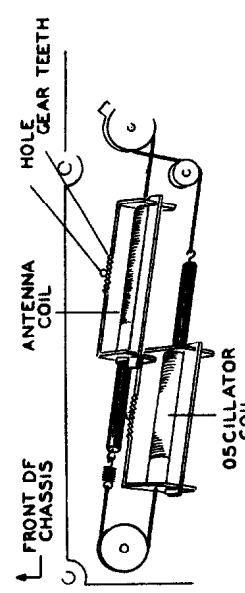

View of Coil Assembly

The antenna coil assembly is movable left to right. When making the adjustment as required in the alignment procedure, move the coil assembly very slowly, either by hand or by pivoting one edge of a screwdriver blade in the hole and engaging the blade in the gear teeth of the coil form.

Intermediate Freq.....455 kc.

MANUAL OF 1949 MOST-OFTEN-NEEDED RADIO DIAGRAMS

BENDIX MODEL 65P4

Circuit Aligned	Input Freq.	Pointer Position	Adjustments
IF	*455 KC	Max. to right	C9b, C9a, C7b, C7a
OSC.	**1475 KC	1475 Ref. Mark	C1c
RF	**1475 KC **965 KC **580 KC	1475 965 580	C1e, C2 +Check Calibration

* Applied to Antenna Input through .1mfd or less.

** Applied to Antenna Input through 50mmf. or less.

+ If dial pointer calibration is not within plus or minus 10 KC the gang rotor plates must be bent to cause correct tracking.

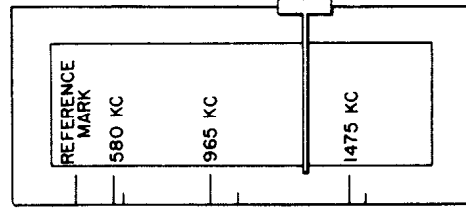
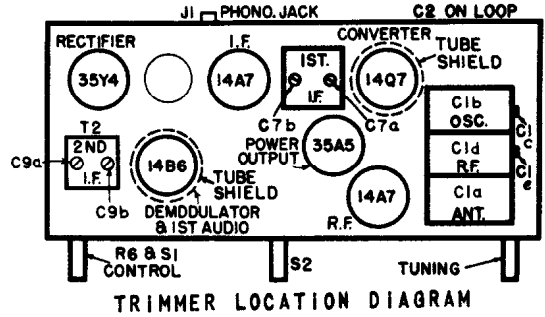

CONDITIONS OF MEASUREMENTS
 LINE VOLTAGE 117 A.C. ZERO SIGNAL VOL. CONT. MIN. SOCKET VOLTAGE RESISTANCE TO COMMON B MINUS D.C. AT 20,000Ω A.C. AT 1,000Ω/V.

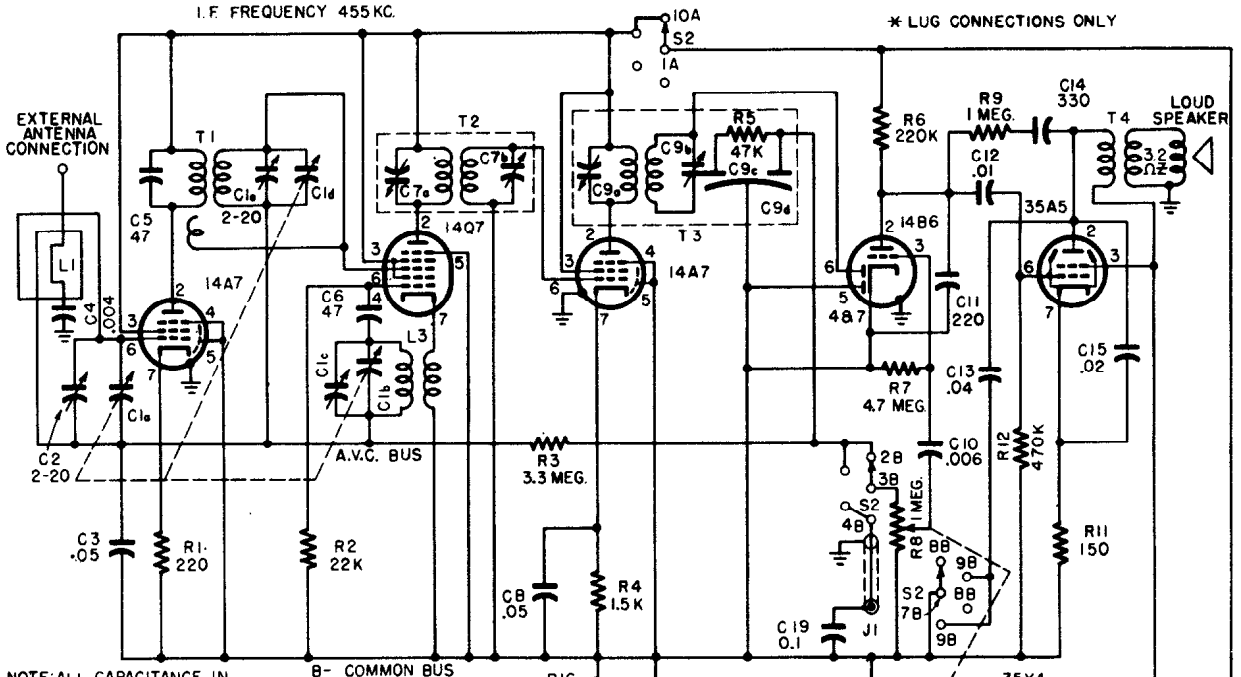
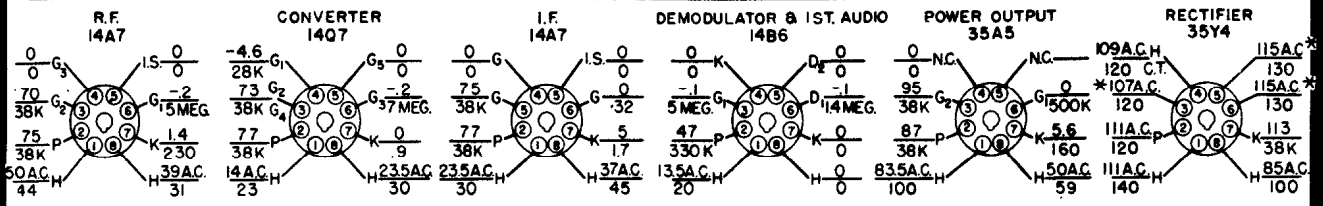

NOTE: ALL CAPACITANCE IN WHOLE NUMBERS IN MMF. AND ALL CAPACITANCE IN DECIMALS IN MF. ALL RESISTANCE IN OHMS UNLESS OTHERWISE STATED.
 K = 1,000 Ω

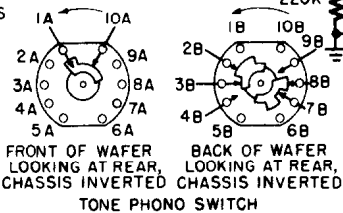

Bendix Radio

MANUAL OF 1949 MOST-OFTEN-NEEDED RADIO DIAGRAMS

CONDITIONS OF MEASUREMENTS
 VOLTAGE 117 A.C. ZERO SIGNAL INPUT. VOL. CDNT. MIN. SOCKET VOLTAGE RESISTANCE TO CHASSIS GROUND. D.C. AT 20,000Ω/V. A.C. AT 1,000Ω/V. SWITCH S1 CLOSED.

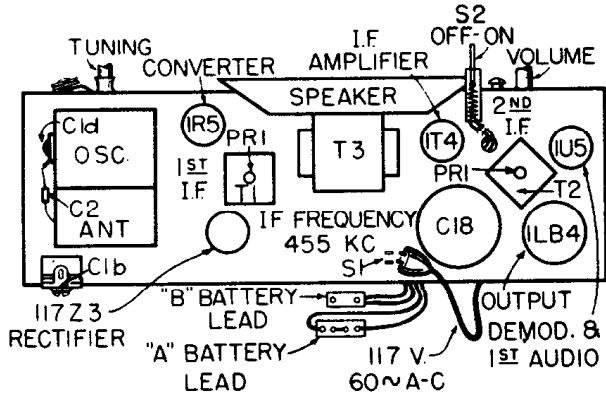
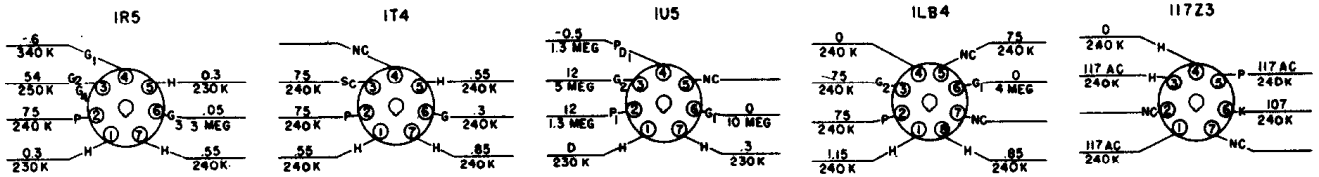

Bendix Radio 55X4

CIRCUIT ALIGNED	DIAL POINTER	INPUT FREQ.	APPLY THROUGH	ADJUST
IF	Max. To Right	†455KC	.01 mfd	SLUGS-Top & Bottom of T2 SLUGS-Top & Bottom of T1 (Fig. 3)
OSC. & ANT.	1475 Ref. Mark (Fig. 4)	1475KC	50 mmf	C1d;C1b (Fig. 3)
	965 Ref. Mark (Fig. 4)	965KC	50 mmf	* Check Calibration
	580 Ref. Mark (Fig. 4)	580KC	50 mmf	* Check Calibration

† If calibration does not check within the frequency mark, both oscillator and antenna sections of the gang condenser must be bent to correct tracking.

* Signal Generator connected to external antenna connection for complete alignment.



Dial Stringing Diagram

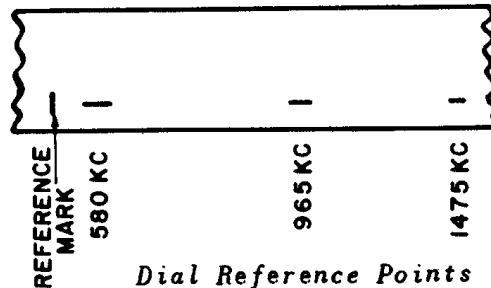
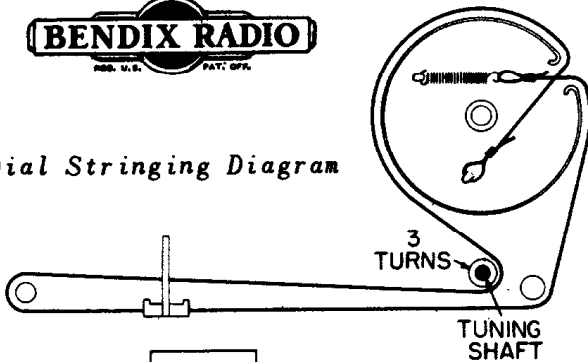

Dial Reference Points

NOTES
 UNLESS OTHERWISE STATED CAPACITANCE IN WHOLE NUMBERS IN MMF, CAPACITANCE IN DECIMALS IN MF, RESISTANCE IN OHMS K = 1000Ω

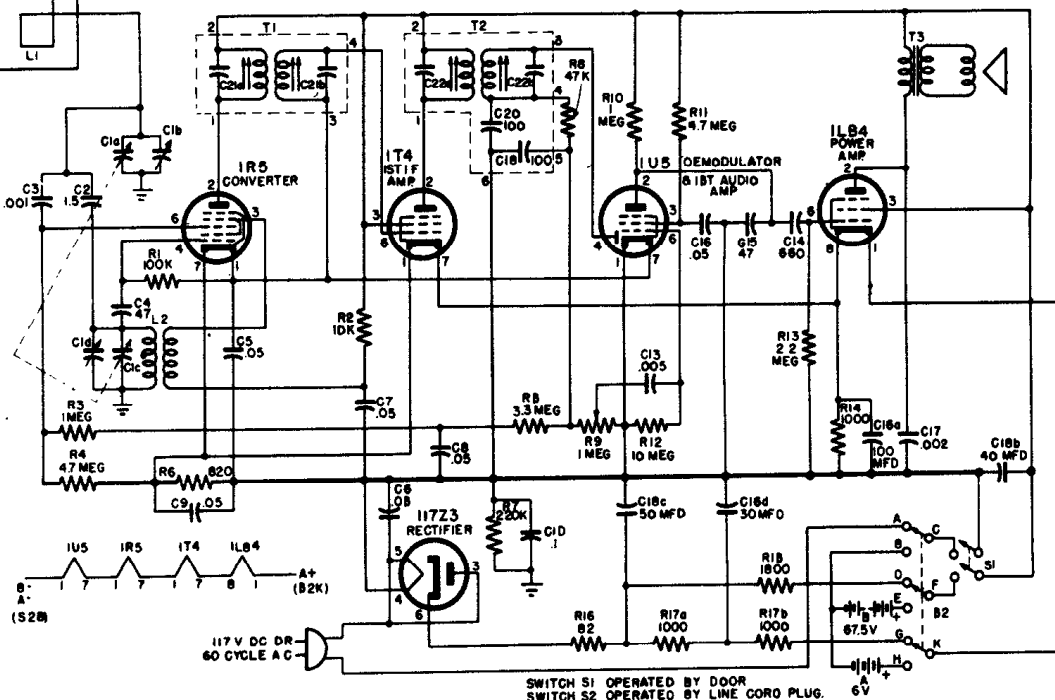

SWITCH S1 OPERATED BY DOOR SWITCH S2 OPERATED BY LINE CORD PLUG.

MANUAL OF 1949 MOST-OFTEN-NEEDED RADIO DIAGRAMS

GROSELY

MODELS: 88TA, 88TC

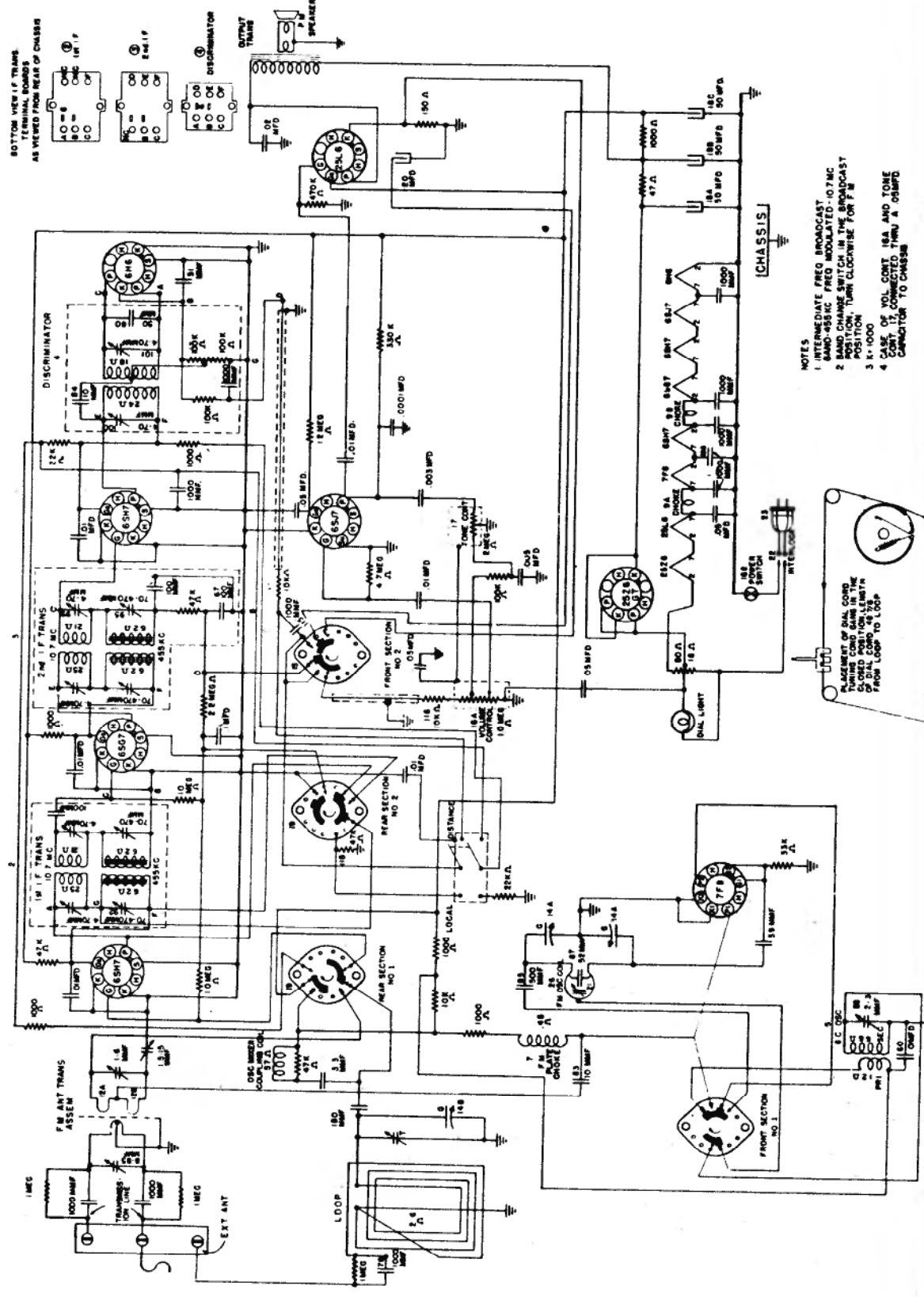

- NOTES
1. IMMEDIATE FREQ. BROADCAST
 2. BAND-455 KC. FREQ. INDICATED TO 7 MC
 3. BAND CHANGE SWITCH IN THE BROADCAST POSITION, TURN CLOCKWISE FOR FM
 4. VOL. CONT. 18A AND TONE CONTROL THRU A .05MFD CAPACITOR TO CHASSIS

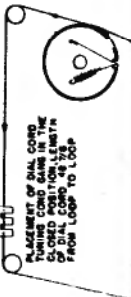

BOTTOM VIEW IF TRANS
TERMINAL BOARDS
AS VIEWED FROM REAR OF CHASSIS

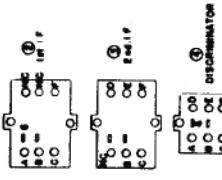

ENDING
ENTS

CHASSIS TOP VIEW SH
ALIGNMENT ADJUSTM

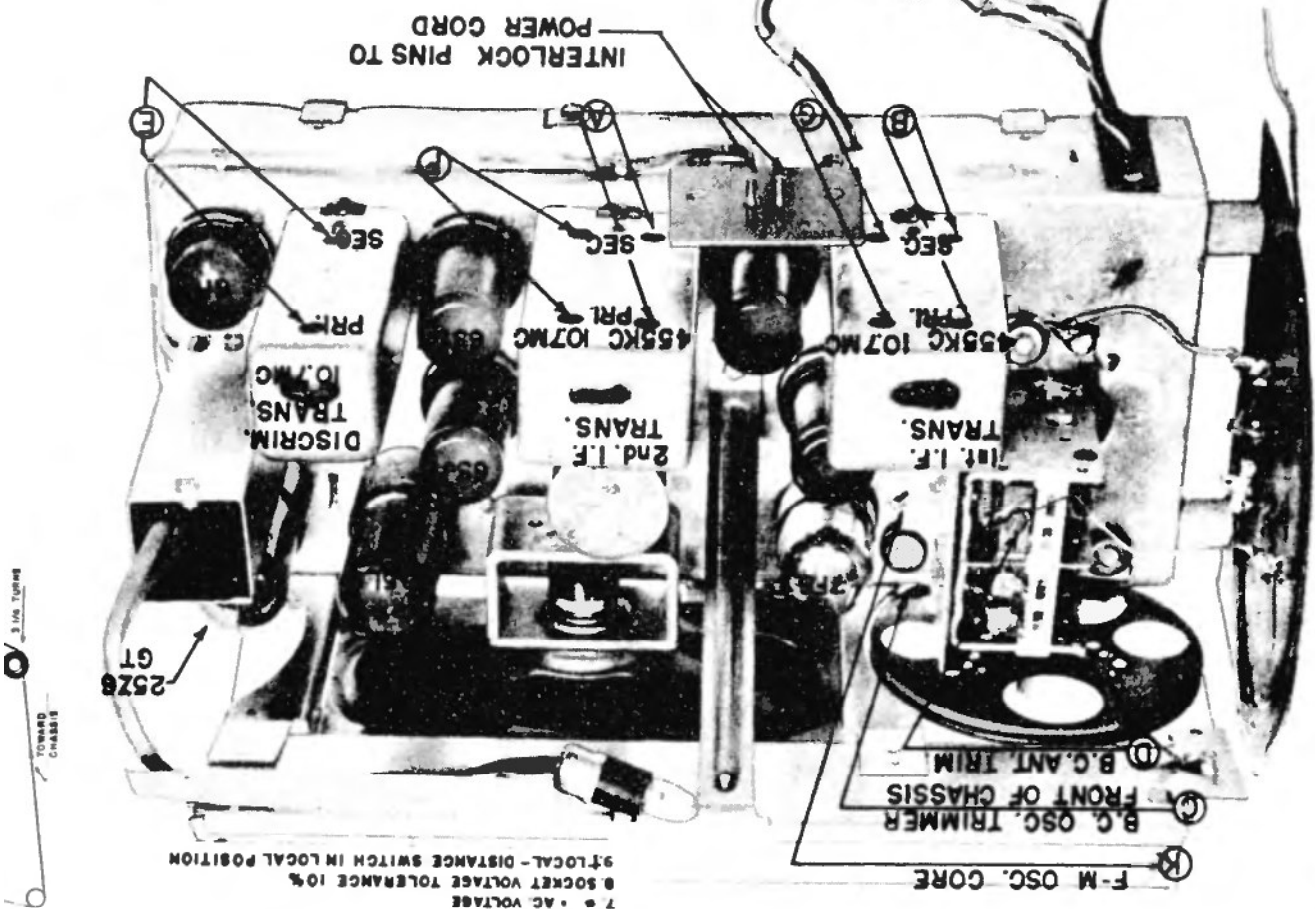

3.146 TUBING
TOWARD CHASSIS

NOTES:
1 BOTTOM VIEW OF TUBE SOCKETS
2 MEASURE VOLTAGE WITH AN ELECTRONIC VOLTMETER
3 ALL VOLTAGES ARE THE SAME FOR BC & FM EXCEPT WHERE MARKED WITH DELTA (Δ). THIS IS THE VOLTAGE WITH BAND SWITCH IN THE FM POSITION
4 LINE VOLTAGE 117V 60~
5 NC - NO CONNECTION
6 WJ - WINDING JUNCTION
7 - AC VOLTAGE
8 SOCKET VOLTAGE TOLERANCE 10%
9 LOCAL-DISTANCE SWITCH IN LOCAL POSITION

SOCKET VOLTAGE CHART

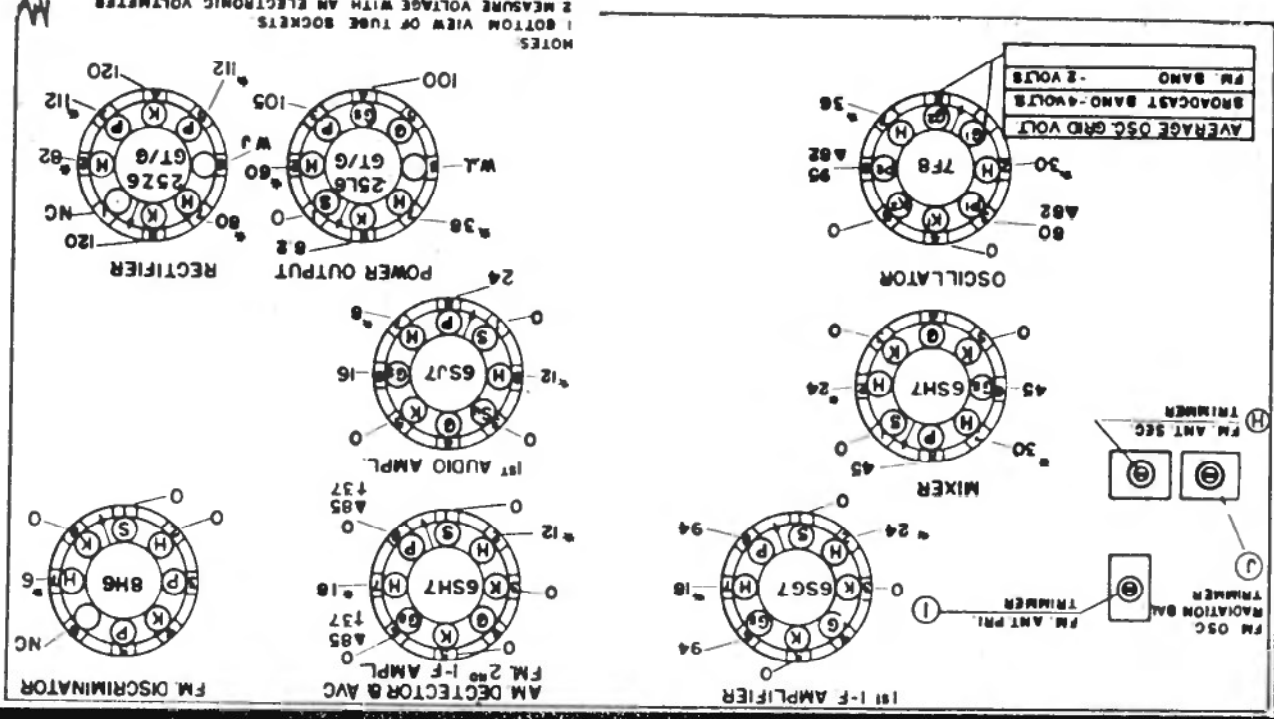

RECTIFIER

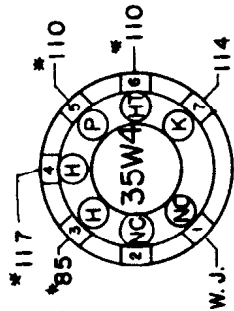

RE. AMPLIFIER

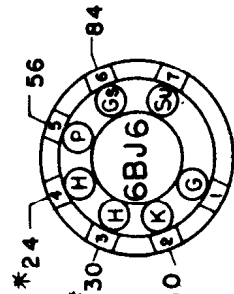

I.F. AMPLIFIER

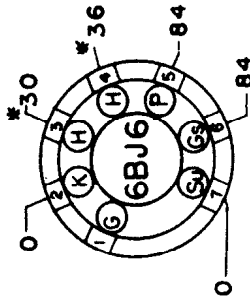

OUTPUT

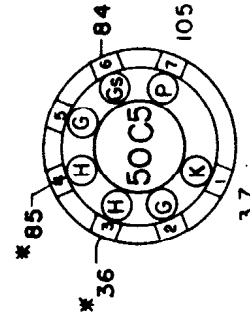

CONVERTER

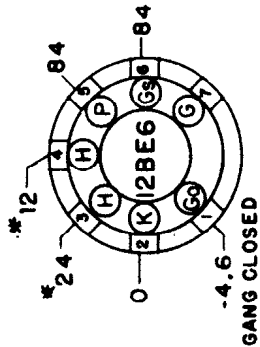

DET. AVC. & 1st AUDIO AMPLIFIER

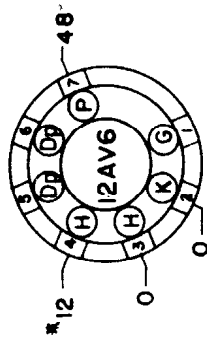

NOTES:

1. BOTTOM VIEW OF TUBE SOCKETS.
2. VOLTAGE MEASURED WITH AN ELECTRONIC VOLTMETER FROM SOCKET LUG TO 8-.
3. LINE VOLTAGE 117 V. 60 CYCLE.
4. NC=NO CONNECTION.
5. W.J.= WIRING JUNCTION.
6. * =AC.VOLTAGE.
7. SOCKET VOLTAGE TOLERANCE $\pm 10\%$.

SOCKET VOLTAGE CHART

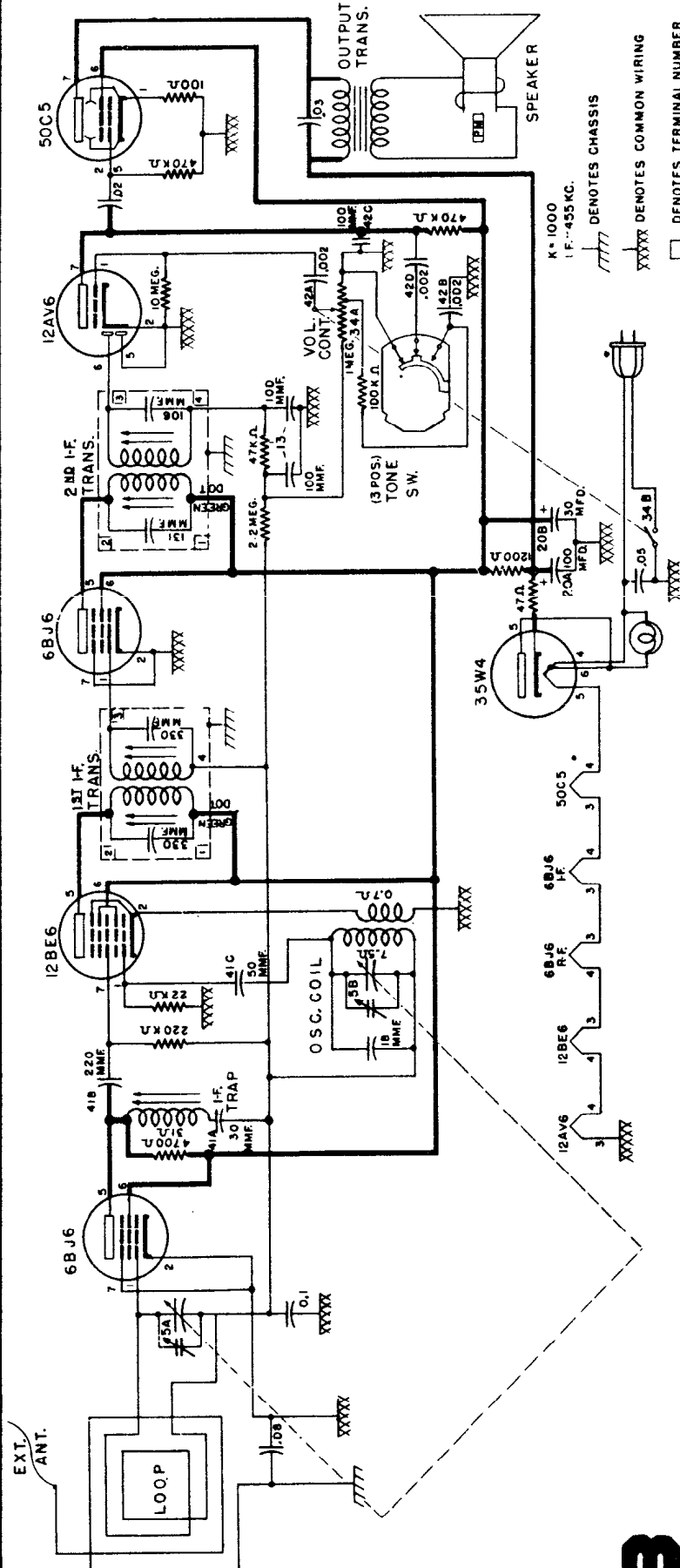

K=1000
M=1000000
F.=455 KC.
XXXXX DENOTES CHASSIS
XXXXX DENOTES COMMON WIRING
□ DENOTES TERMINAL NUMBER

MANUAL OF 1949 MOST-OFTEN-NEEDED RADIO DIAGRAMS

CROSLLEY

MODELS: 9-103, 9-104W

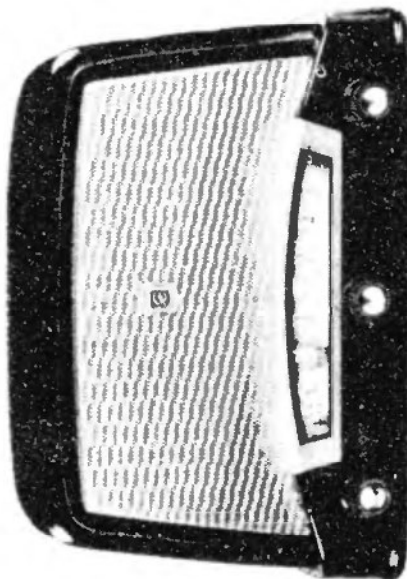

9-103

FREQUENCY RANGE: 540 to 1600 kc.

INTERMEDIATE FREQUENCY: 455 kc.

TUNING CONDENSER GANG
IN THE CLOSED POSITION
LENGTH OF DIAL CORD 35"

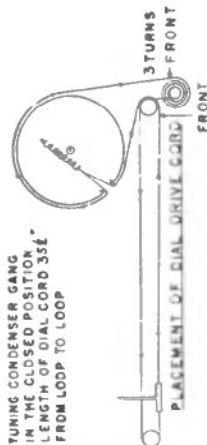

*NOTE:

- RECEIVERS WITH TUBE SHIELD
USE 50B5 TUBE.
- RECEIVERS WITHOUT TUBE SHIELD
USE 50C5 TUBE.

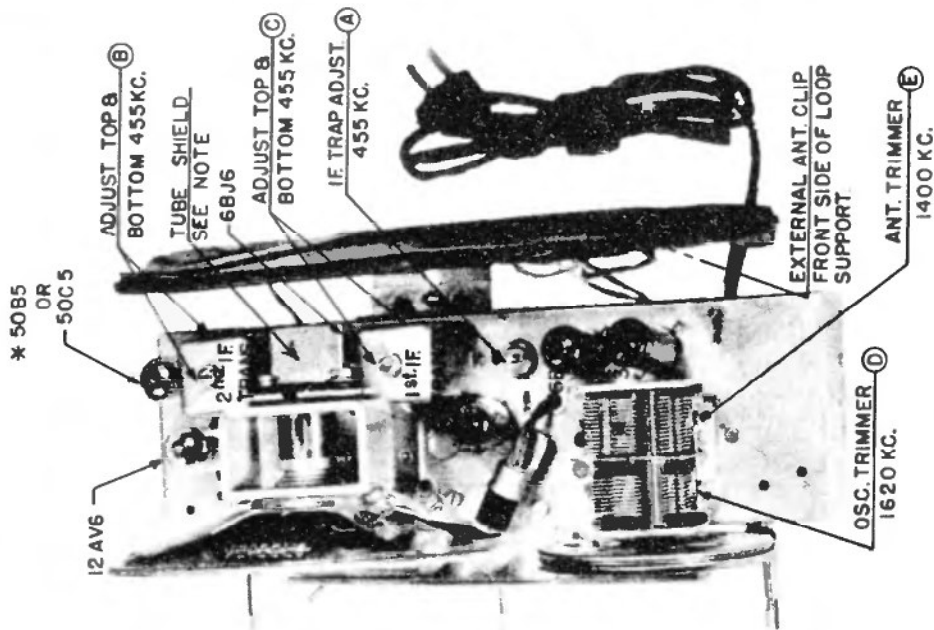

CHASSIS, VIEW

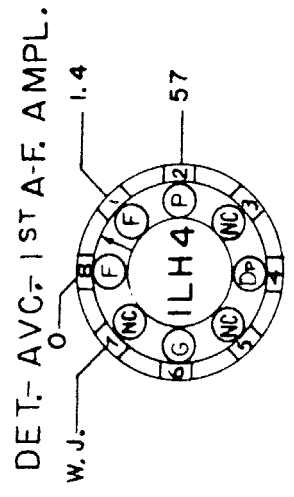
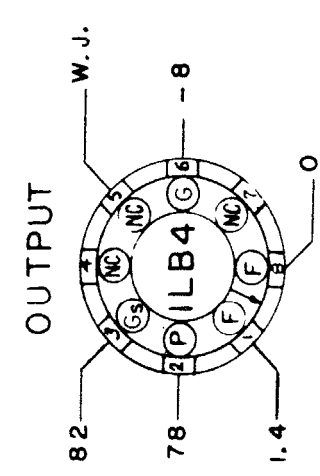
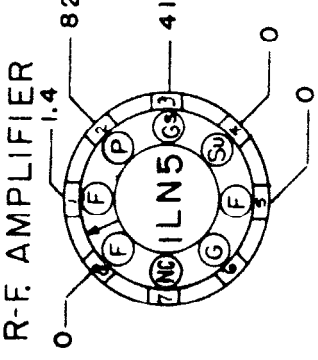
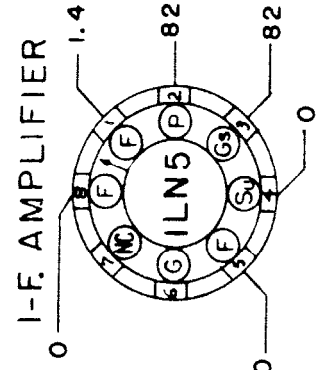
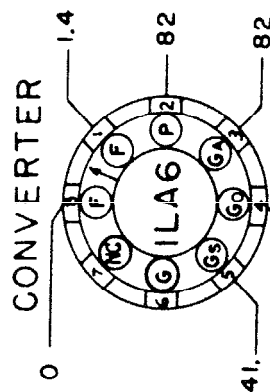

OSC. GRID VOLTAGE
GANG OPEN -11 VOLTS
GANG CLOSED -8 VOLTS

- NOTES:
1. BOTTOM VIEW OF TUBE SOCKETS
 2. VOLTAGES MEASURED FROM SOCKET LUG TO CHASSIS WITH AN ELECTRONIC VOLTMETER
 3. W.J. = WIRING JUNCTION
 4. N.C. = NO CONNECTION
 5. BATTERY PACK VOLTAGE "A" = 1.4 VOLTS, "B" = 90 VOLTS
 6. SOCKET VOLTAGE TOLERANCE 10 %

CHASSIS REAR VIEW

K * 1000
455 KC. I. F. FREQUENCY

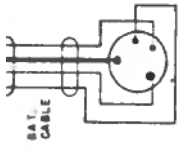
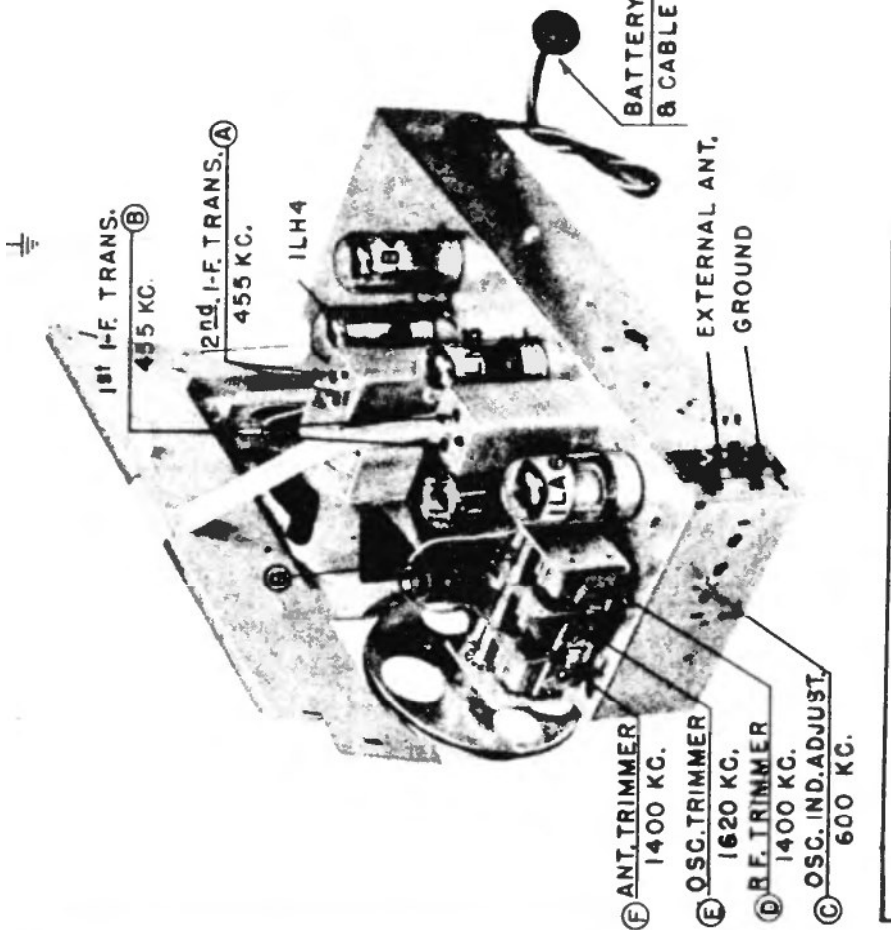

CROSLLEY

MODEL: 9-101

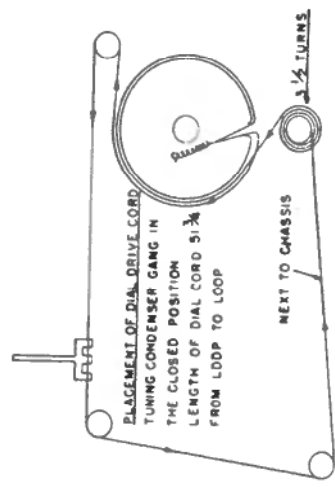

MANUAL OF 1949 MOST-OFTEN-NEEDED RADIO DIAGRAMS

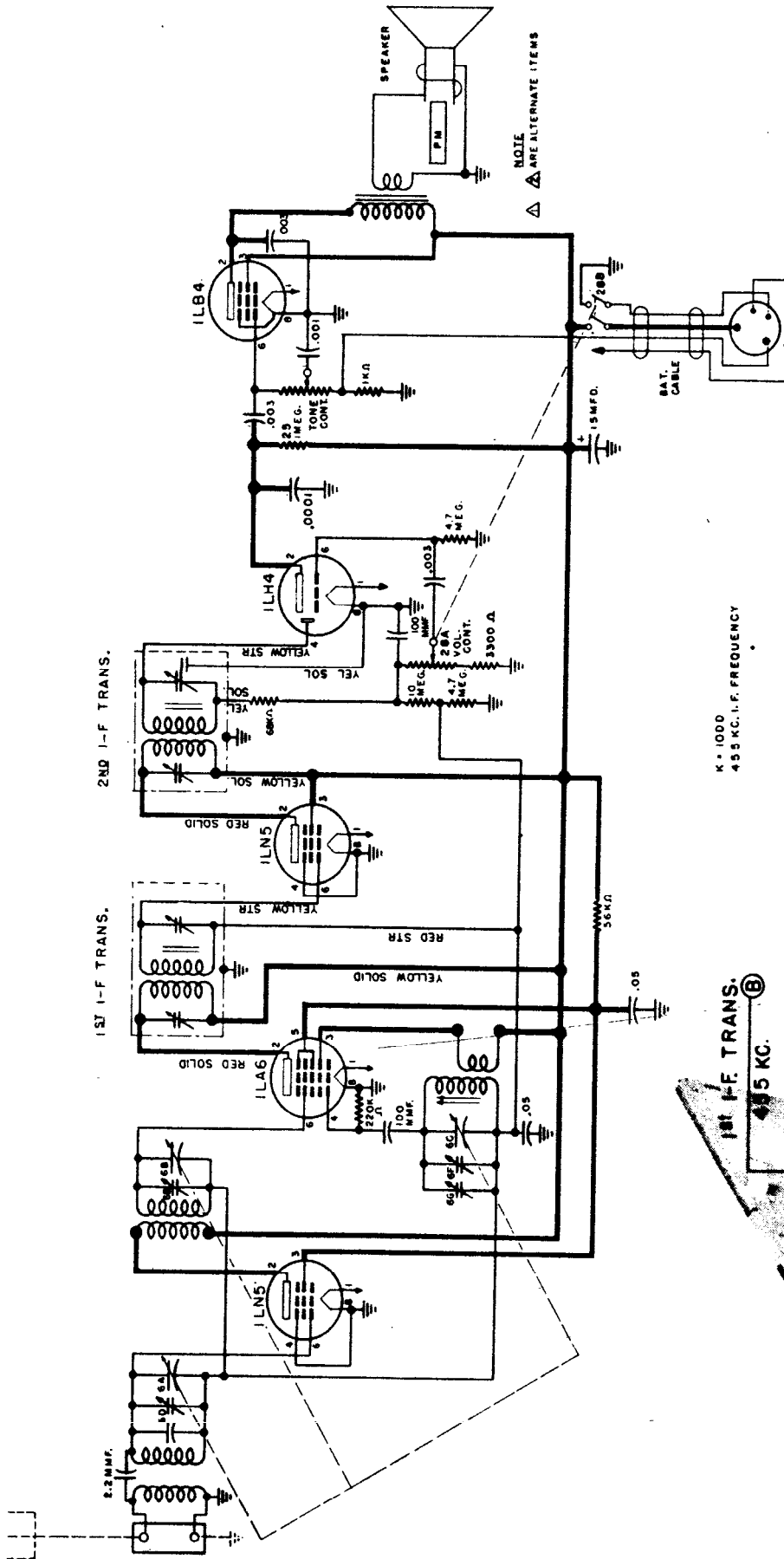

X * 1000
455 KC. I. F. FREQUENCY

1949 I-F TRANS.
455 KC. (B)

NOTE
△ ARE ALTERNATE ITEMS

ALIGNMENT PROCEDURE

Alignment Sequence	Signal Generator Output		Position of Tuning Cond.	Adjust for Maximum Output
	Frequency in kc.	In Series with		
1	455	200 mmf.	Open	A & B
2	1620	*Radiated to Loop	Open	C
3	1400	*Radiated to Loop	Tune to Signal	D

* Place signal generator output lead near the loop antenna.

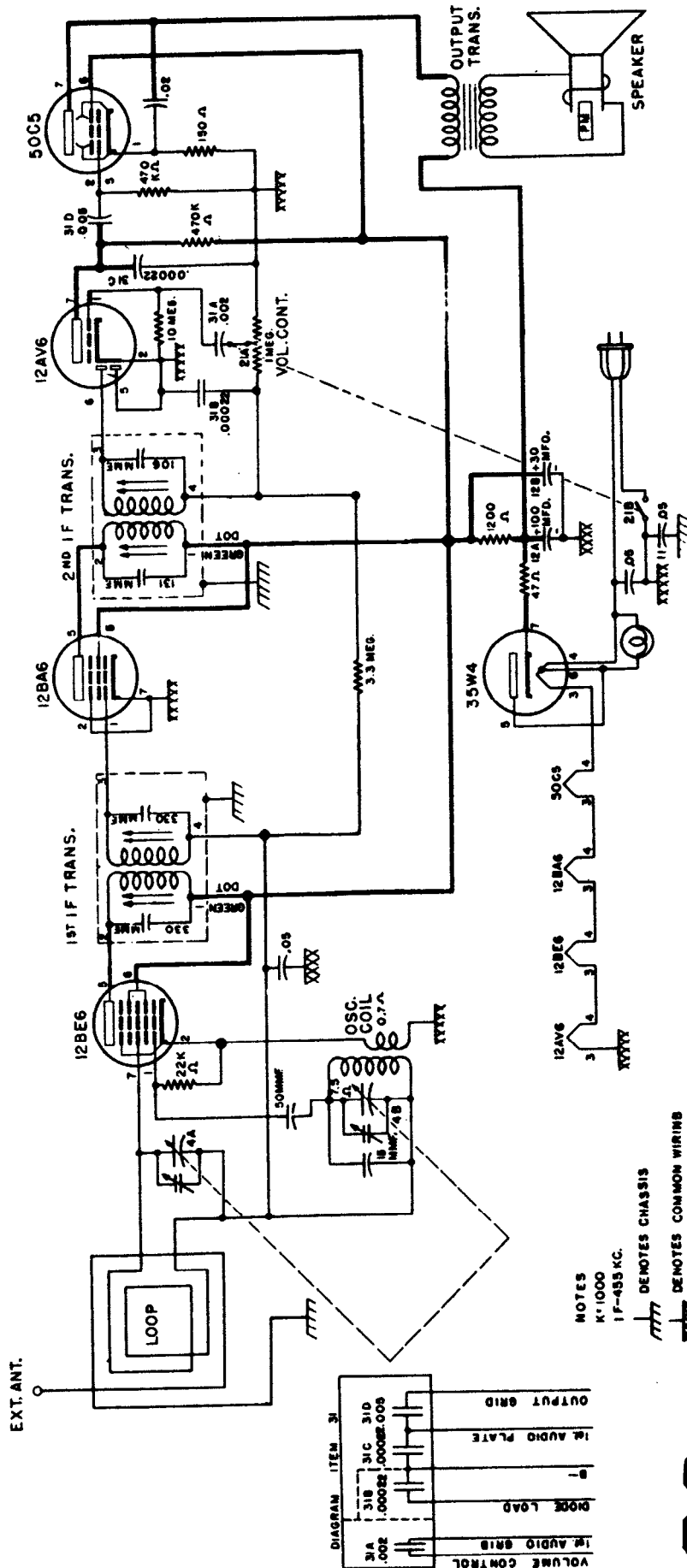

NOTES
 K=1000
 M=1000000
 1F=455 KC.
 XXXX DENOTES CHASSIS
 XXXX DENOTES COMMON WIRING
 ALL CAPACITANCE VALUES IN MICROFARADS UNLESS OTHERWISE NOTED.

SCHEMATIC DIAGRAM (Second Production)

MANUAL OF 1949 MOST-OFTEN-NEEDED RADIO DIAGRAMS

CROSLLEY

MODELS 9-113, 9-114W

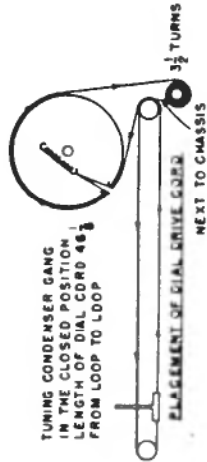
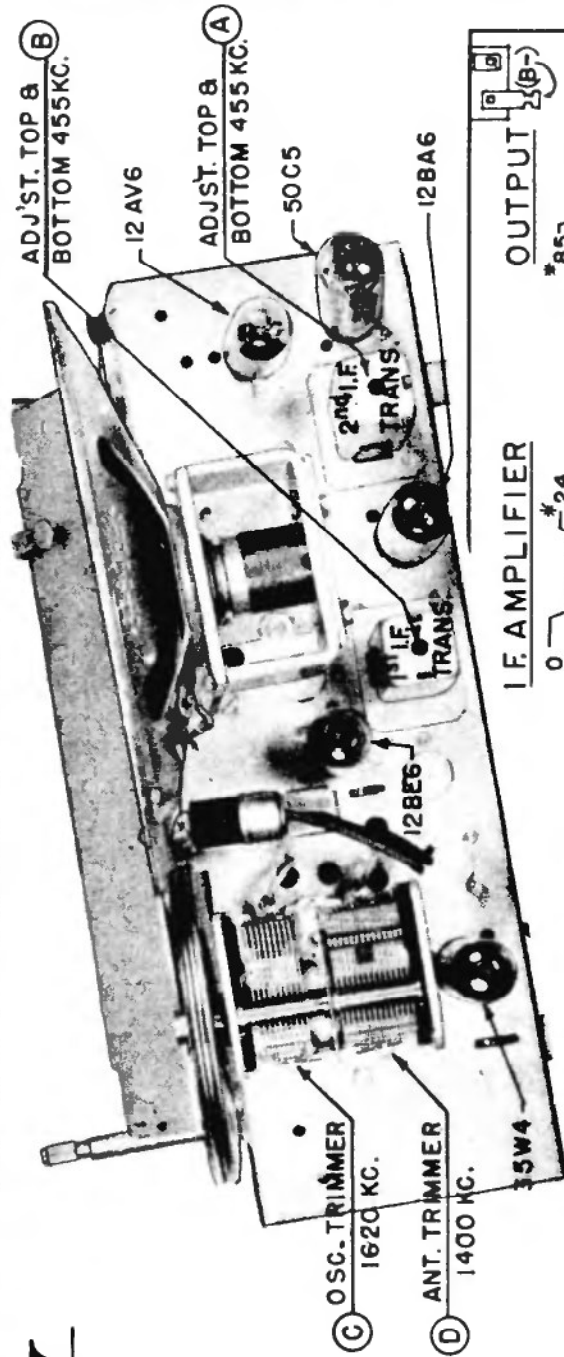

RECTIFIER

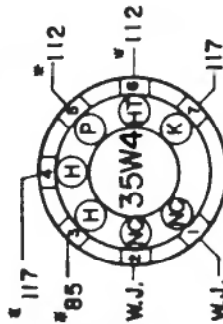

I.F. AMPLIFIER

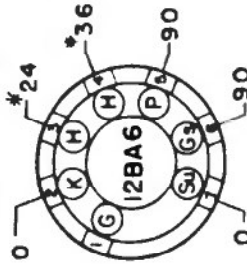

OUTPUT

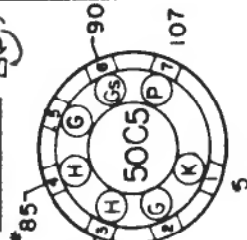

CONVERTER

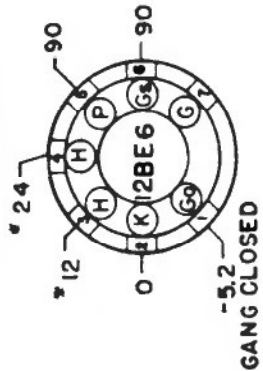

DET. AVC. & 1st AUDIO AMPLIFIER

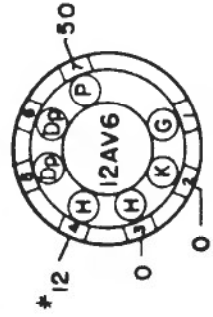

NOTES:

1. BOTTOM VIEW OF TUBE SOCKETS.
2. VOLTAGE MEASURED WITH AN ELECTRONIC VOLTMETER FROM SOCKET LUG TO B-.
3. LINE VOLTAGE 117 V. 60 CYCLE.
4. NC=NO CONNECTION.
5. W.J.= WIRING JUNCTION.
6. * = AC VOLTAGE.
7. SOCKET VOLTAGE TOLERANCE 10%.

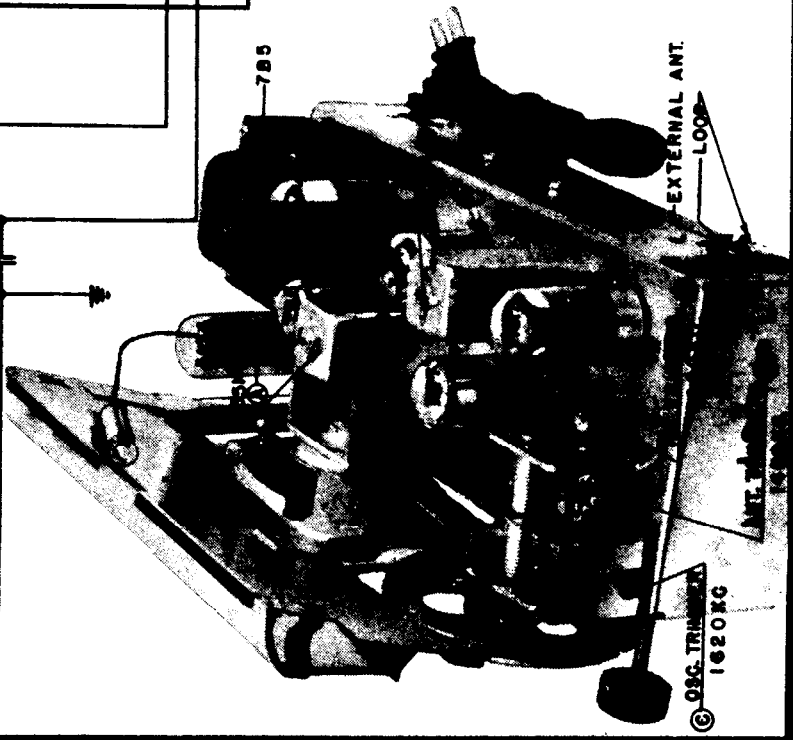
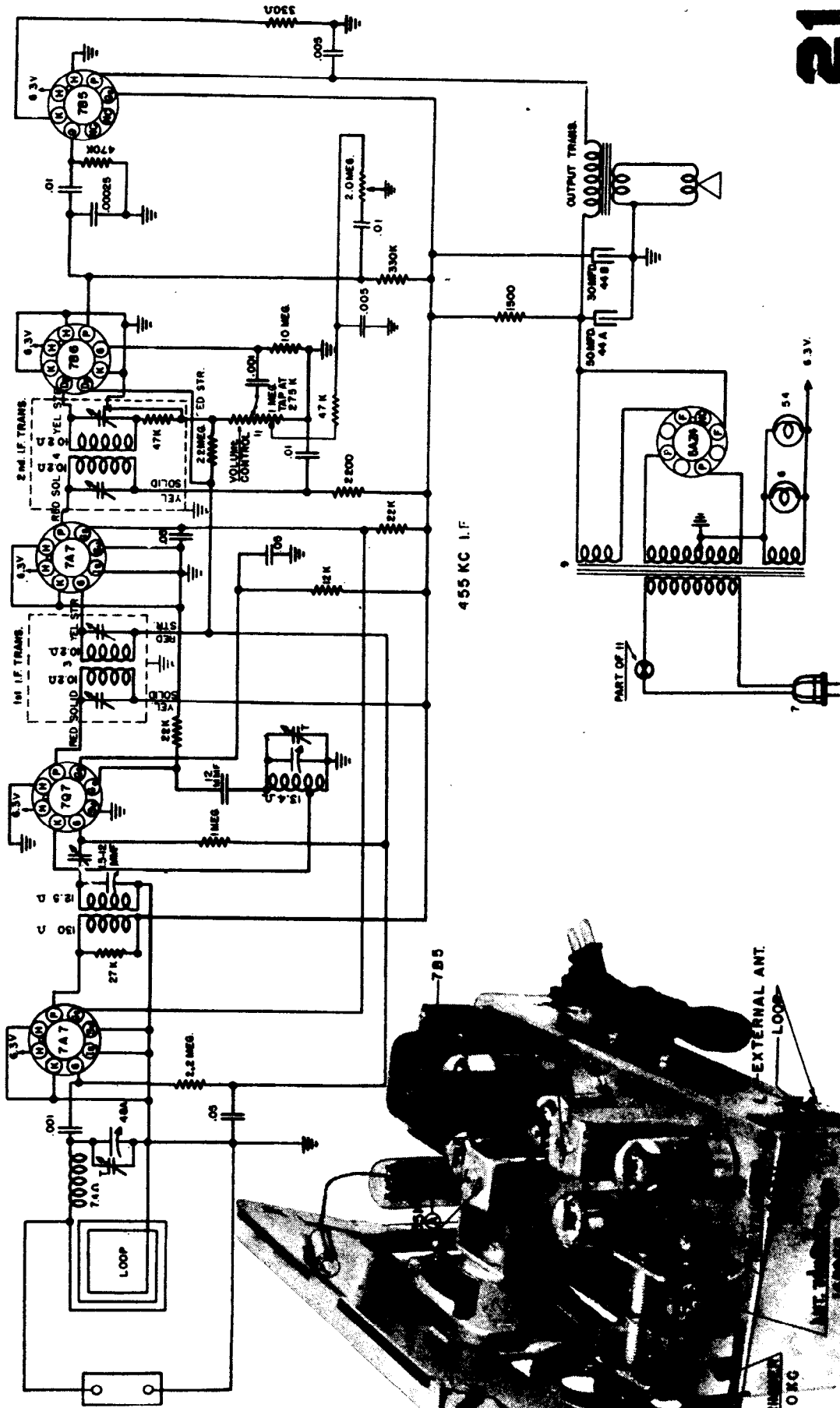

EXTERNAL ANT. LOOP

© OSC. TRIMMER 16203C

MANUAL OF 1949 MOST-OFTEN-NEEDED RADIO DIAGRAMS

CROSLEY

MODELS 9-102, 9-118W

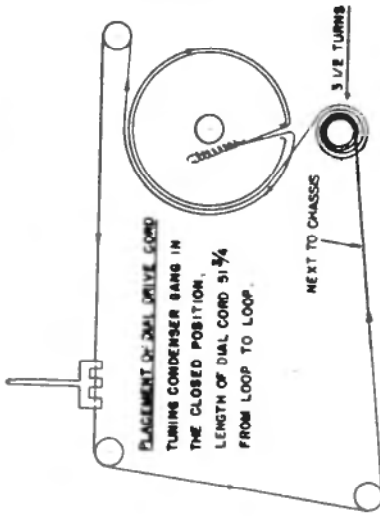

R. F. AMPLIFIER

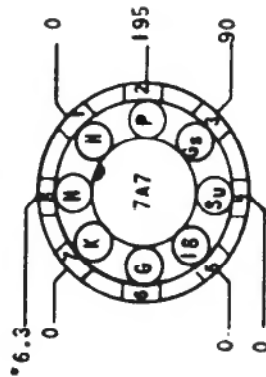

I. F. AMPLIFIER

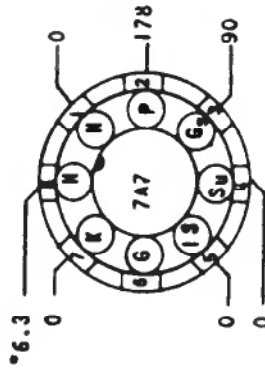

POWER OUTPUT

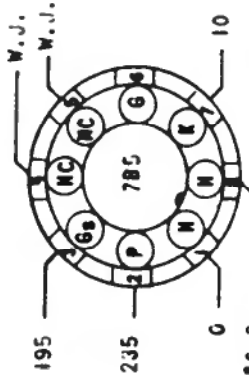

CONVERTER

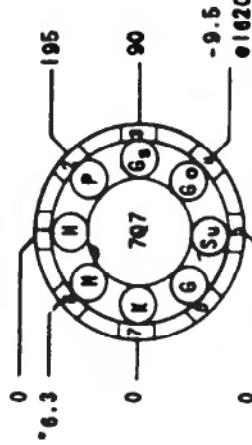

OET.-AVC.-1st. A.F. AMPL.

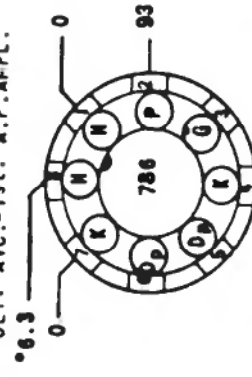

POWER TRANSFORMER

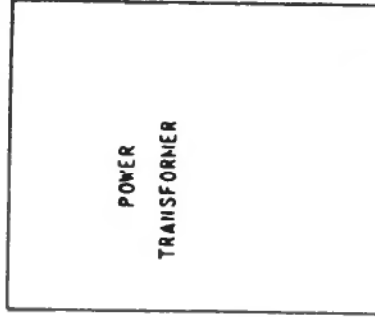

RECTIFIER

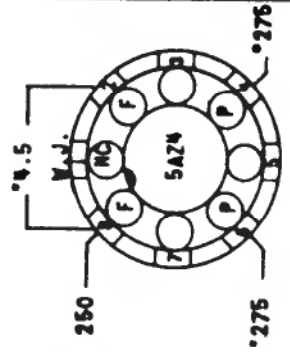

- NOTES:
1. Bottom View Of Sockets
 2. Measure Voltage From Socket Lug To -B (Chassis)
 3. Voltages Measured With An Electronic Voltmeter
 4. W.J. = Wiring Junction.
 5. M.C. = No Connection.
 6. 0 = A.C. Voltage.
 7. Voltage Tolerance, 10%
 8. Line Voltage 117 V, 60 ~ A.C.

SOCKET VOLTAGE CHART

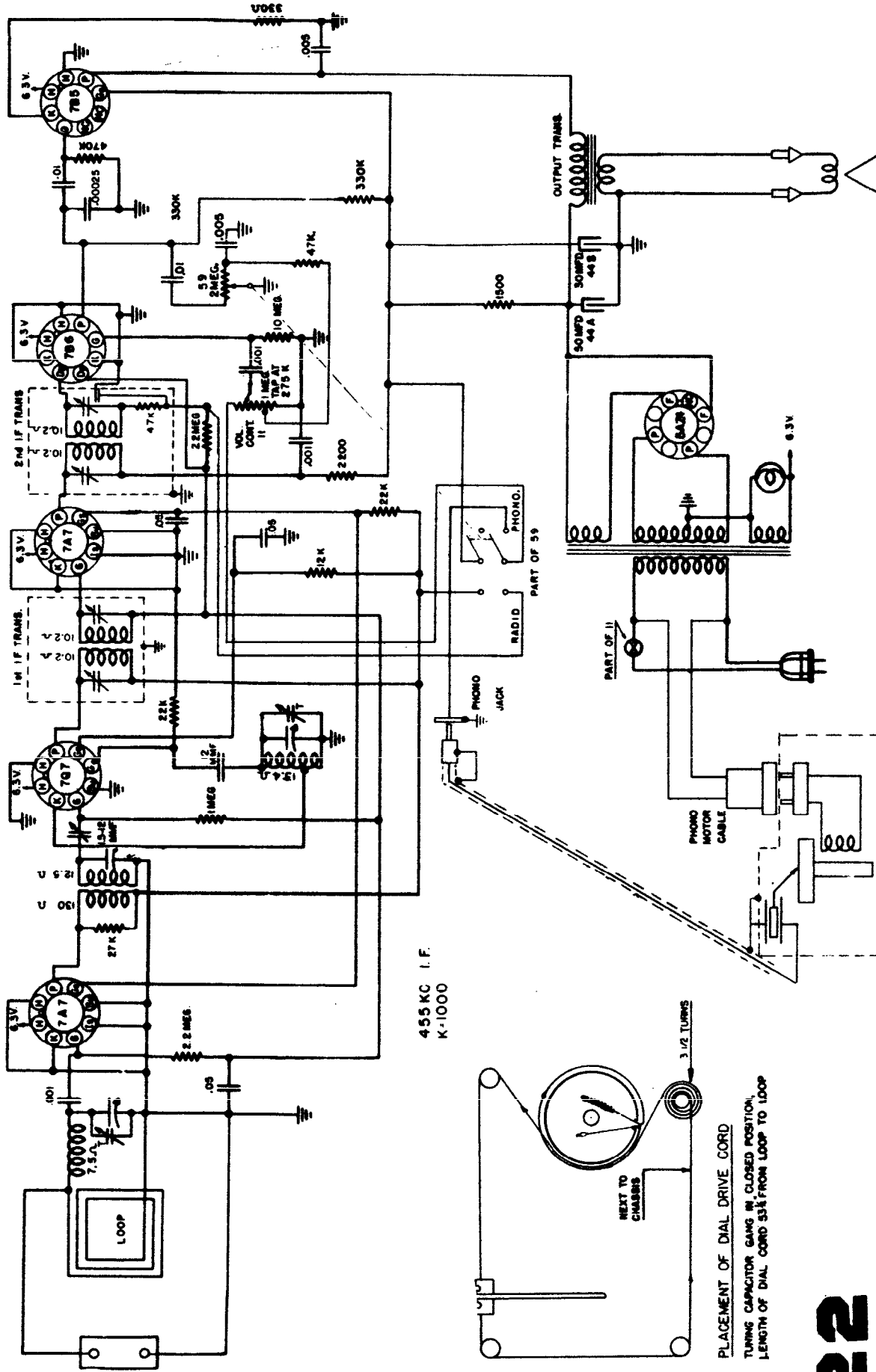

MANUAL OF 1949 MOST-OFTEN-NEEDED RADIO DIAGRAMS

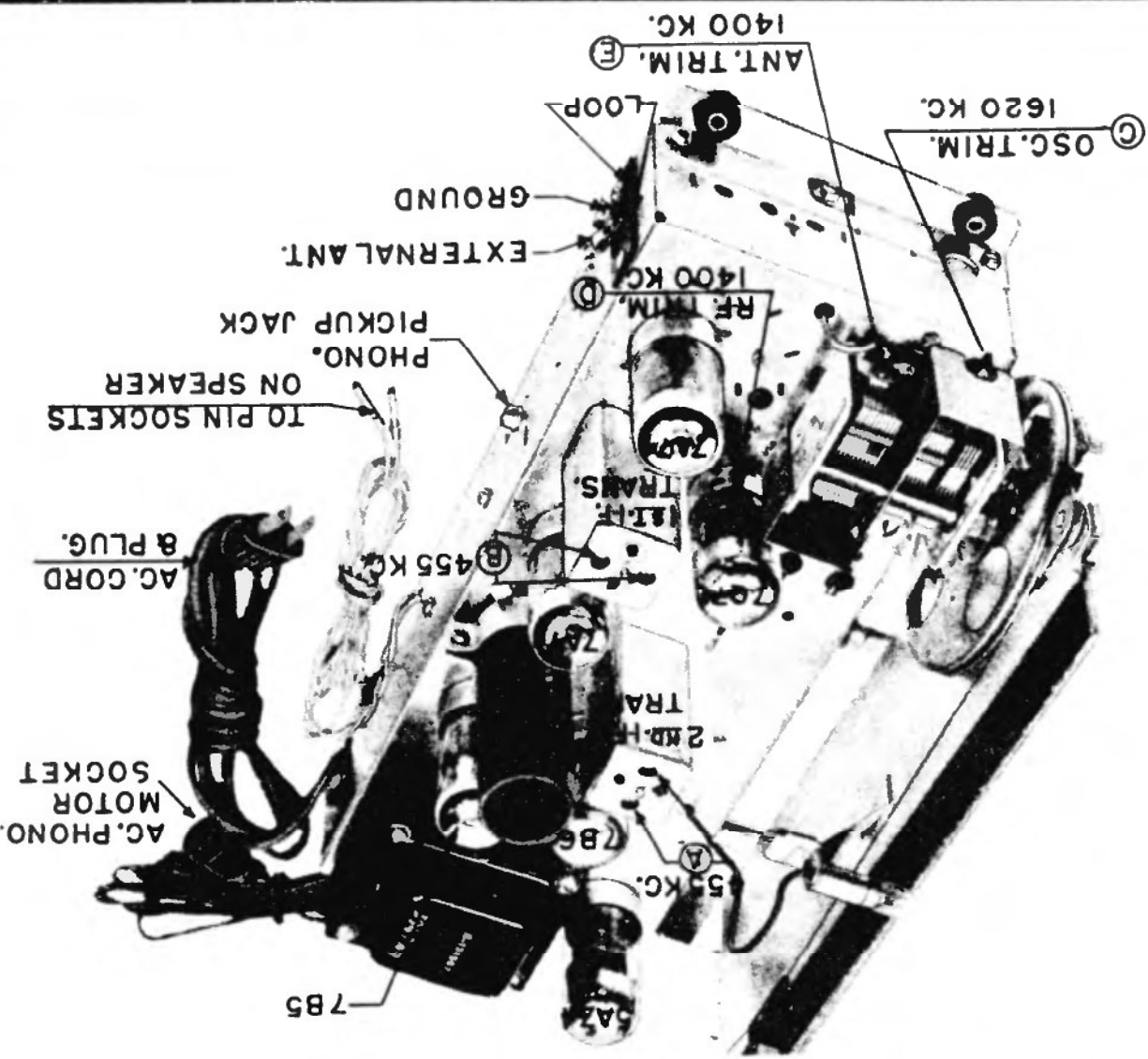
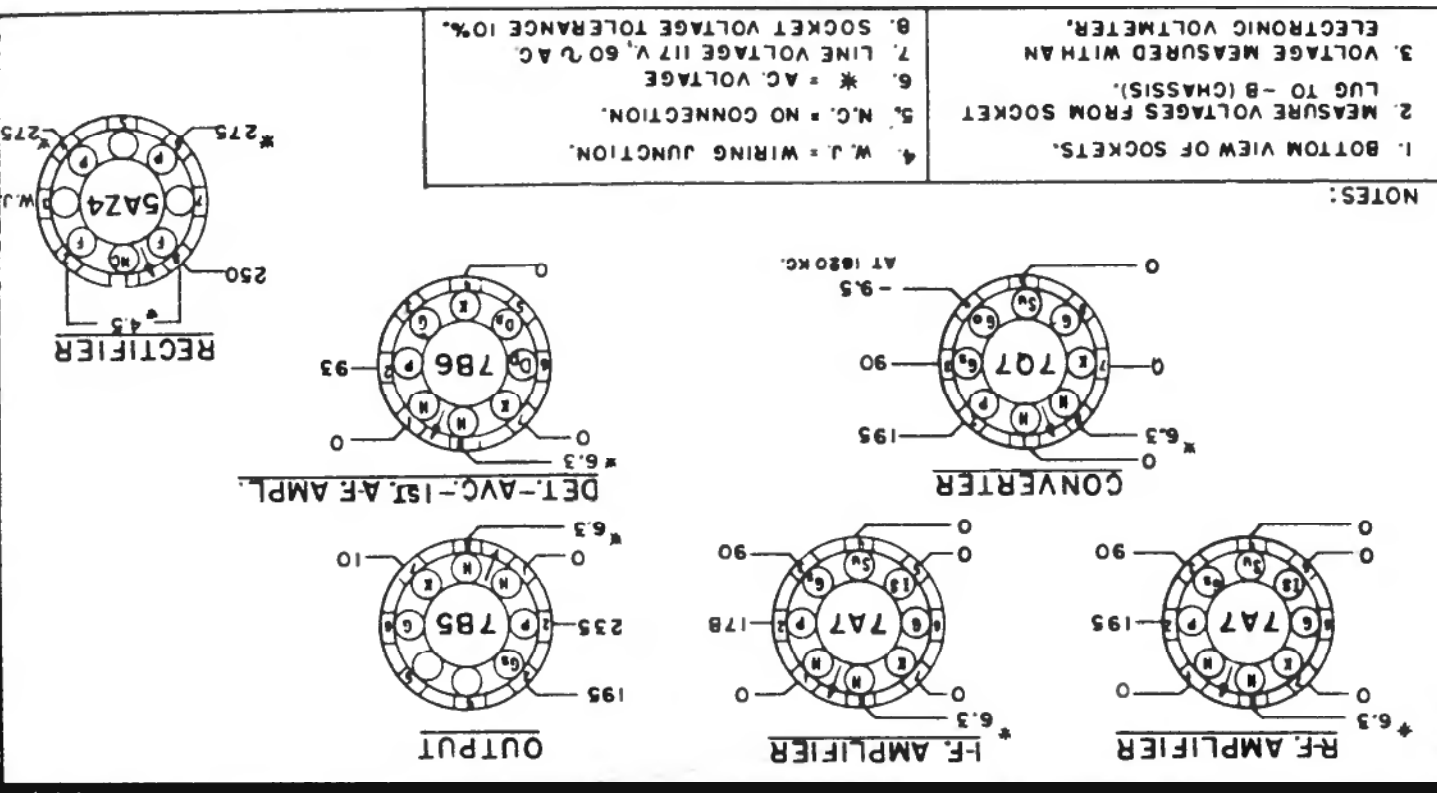

GROSLY

MODELS 9-209, 9-212M

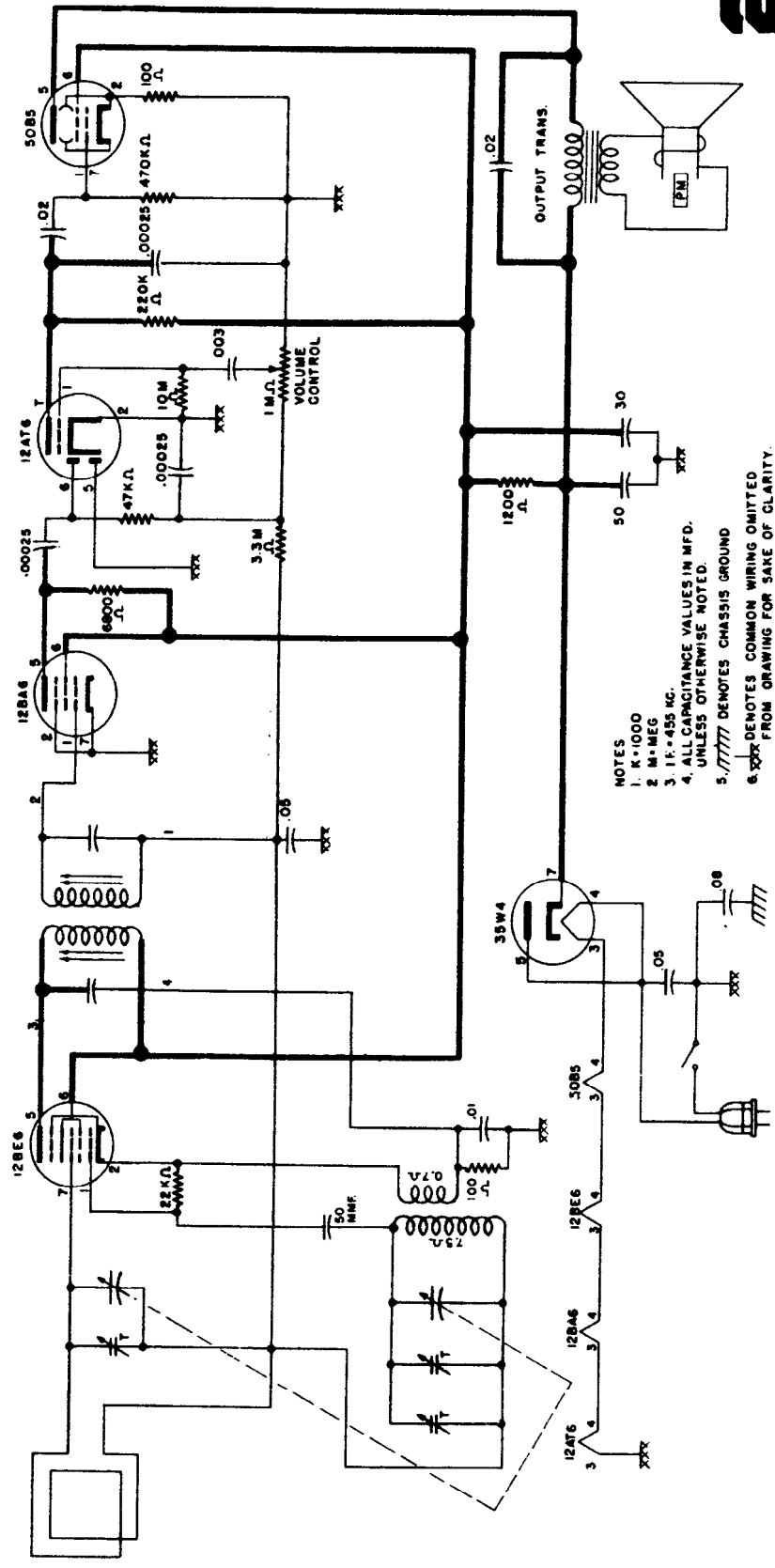

NOTES

1. K = 1000
2. M = MEG
3. LF = 455 KC.
4. ALL CAPACITANCE VALUES IN MFD. UNLESS OTHERWISE NOTED.
5. ////// DENOTES CHASSIS GROUND
6. XXX DENOTES COMMON WIRING OMITTED FROM DRAWING FOR SAKE OF CLARITY.

ALIGNMENT PROCEDURE

1. Connect an output meter across the speaker voice coil.
2. The r.f. signal input from the signal generator should be connected to the high side of loop antenna. Connect the signal generator ground through a 0.1 mfd. condenser to B— (pin 2 on 12BA6 tube socket).
3. Turn the volume control on full and adjust the signal generator output to produce approximately midscale deflection of the output meter, but maintain signal generator output as low as possible to prevent AVC action in the receiver.

Alignment Sequence	Signal Generator Output		Position of Dial Pointer	Adjust for Maximum Output
	Frequency in kc.	In Series with		
1	455	200 mmf.	1620	A
2	1620	*Radiated to Loop	1620	B
3	1400	*Radiated to Loop	1400	C

* Place signal generator output lead near the loop antenna.

MANUAL OF 1949 MOST-OFTEN-NEEDED RADIO DIAGRAMS

CROSLLEY

MODELS 9-119, 9-120W

9-119

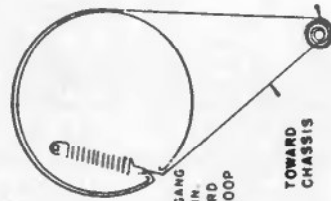
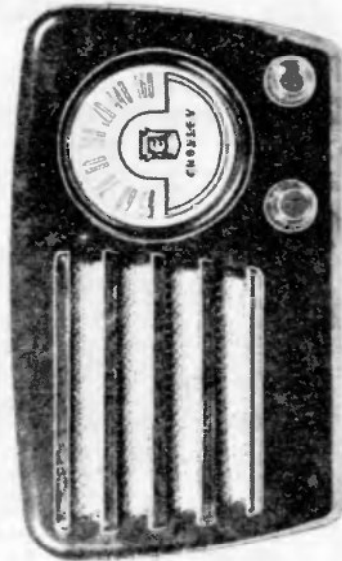

TUNING CONDENSER GANG
IN CLOSED POSITION
LENGTH OF DIAL CORD
1 1/2 INCHES FROM LOOP
16 TO LOOP.

TOWARD
CHASSIS

3 TURNS

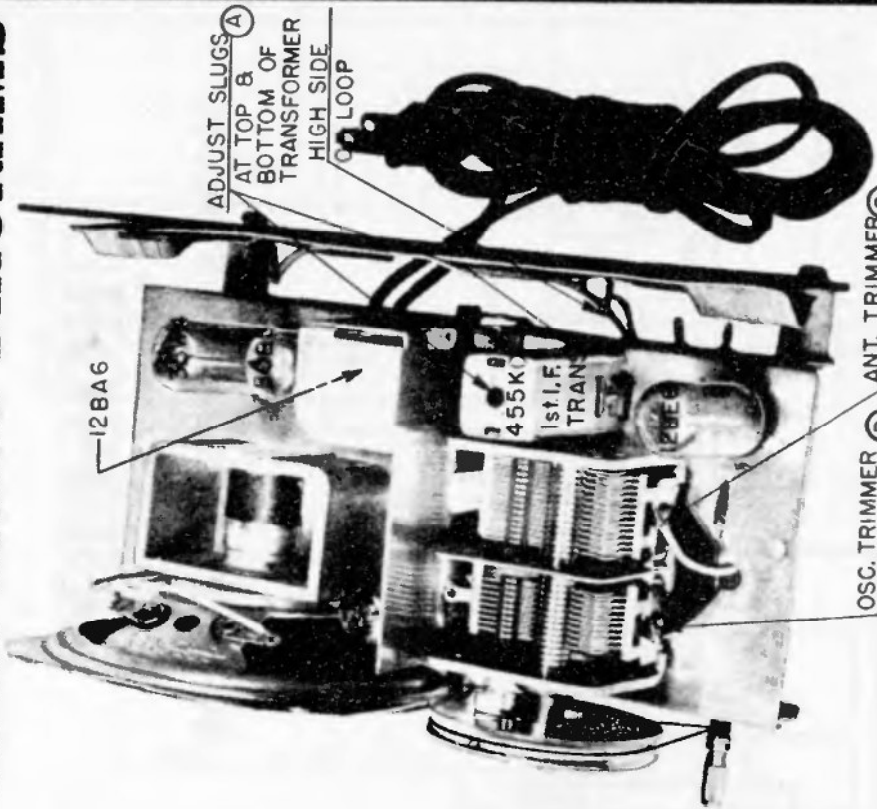

12BA6

ADJUST SLUGS
AT TOP & BOTTOM OF
TRANSFORMER
HIGH SIDE
LOOP

455K
1st I.F.
TRAN.

OSC. TRIMMER ANT. TRIMMER

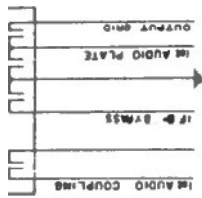

△

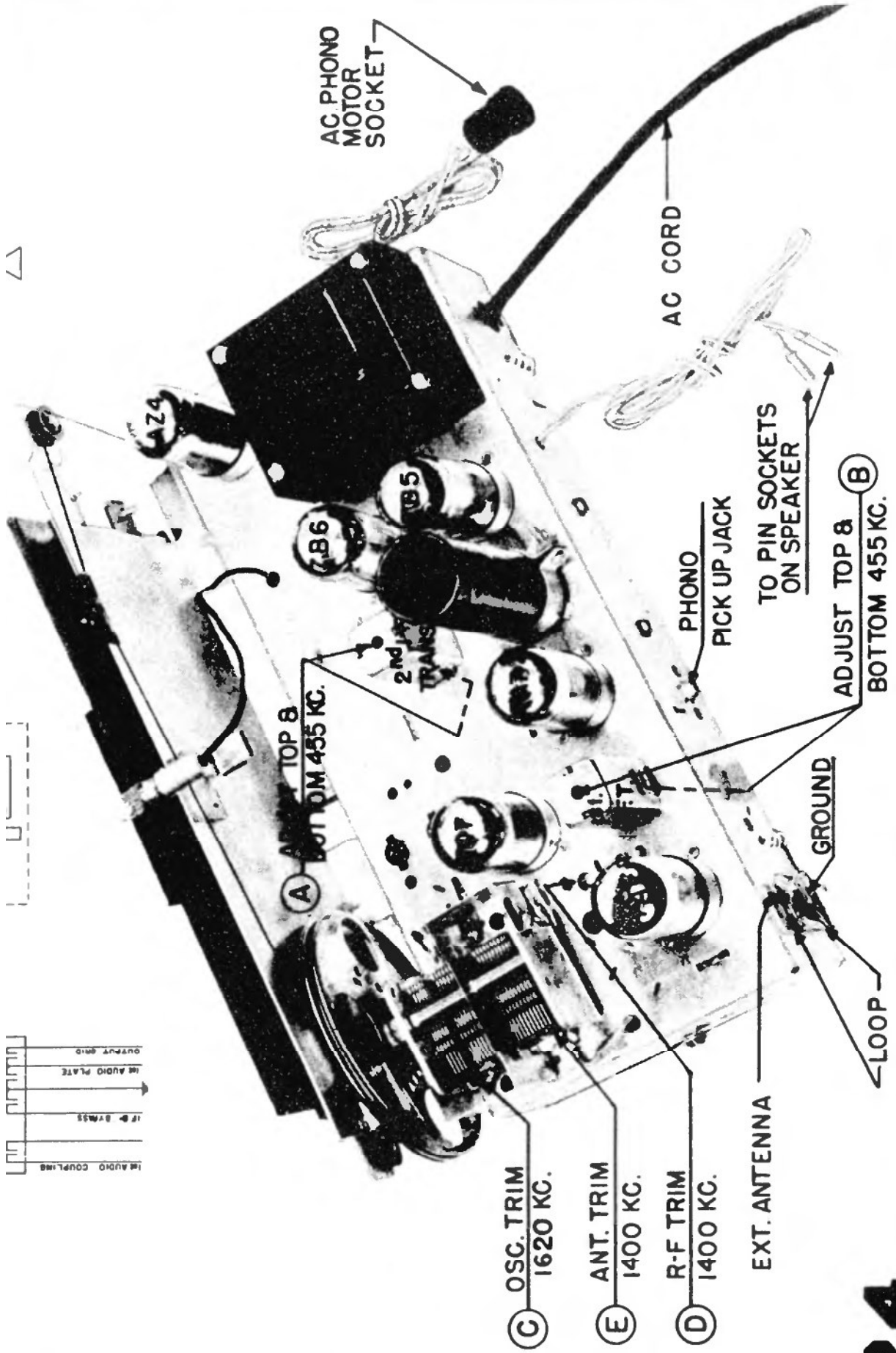

- (C) OSC. TRIM 1620 KC.
- (E) ANT. TRIM 1400 KC.
- (D) R-F TRIM 1400 KC.

CROSLLEY

TYPE: Six-tube, single band, superheterodyne.

FREQUENCY RANGE: 540 to 1600 kc.

INTERMEDIATE FREQUENCY: 455 kc.

POWER SUPPLY: 60 cycle a. c. only

VOLTAGE RATING: 105-125 volts.

MODELS 9-209L, 9-212ML, 9-213B

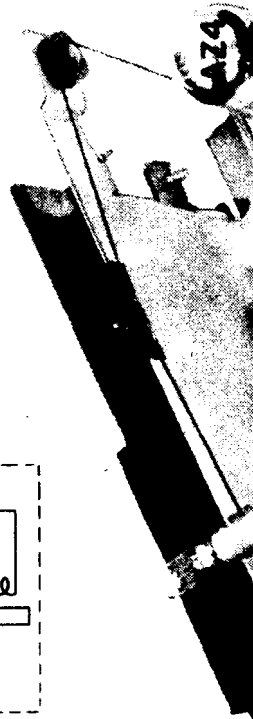
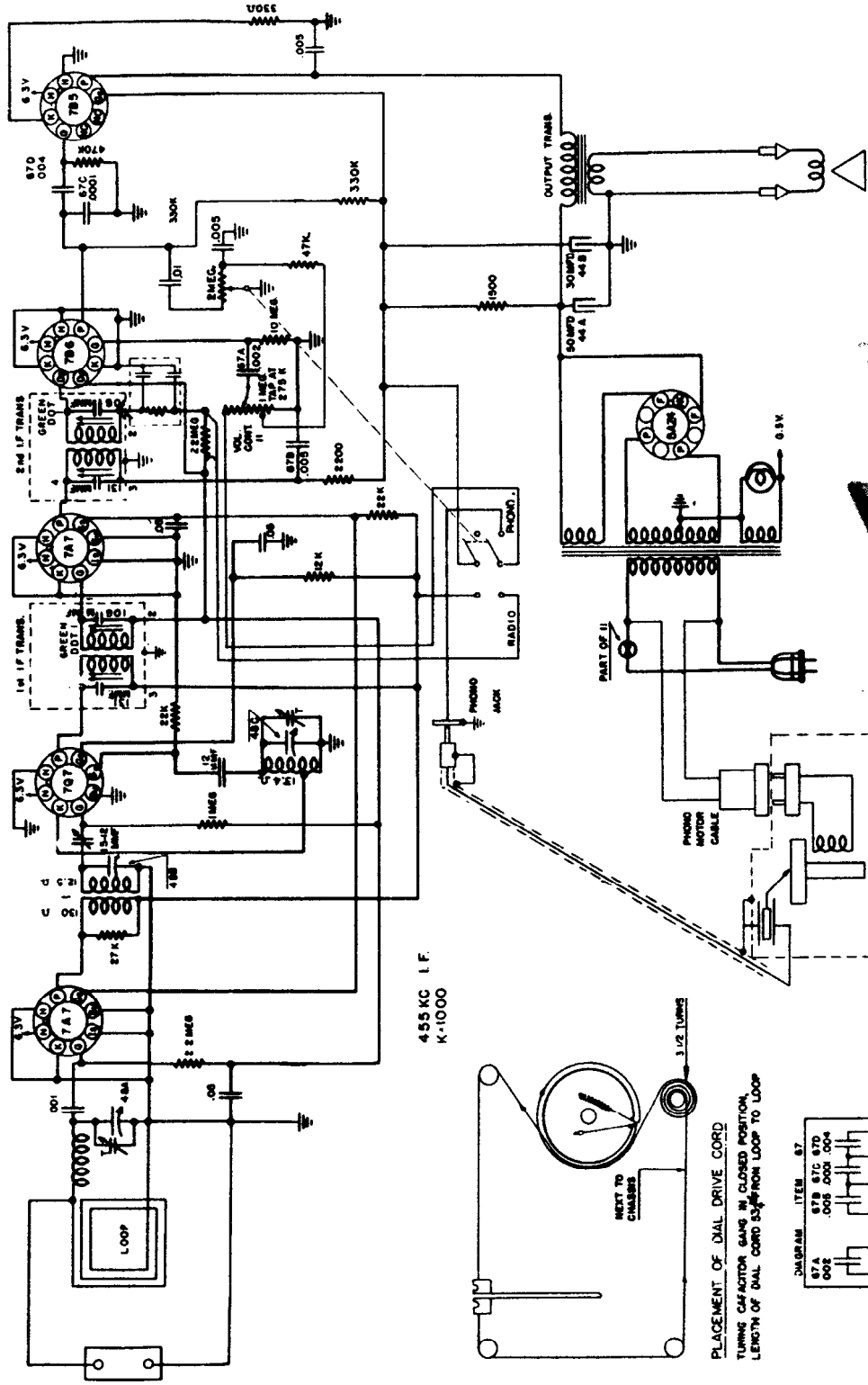

MANUAL OF 1949 MOST-OFTEN-NEEDED RADIO DIAGRAMS

CROSLEY

MODELS 9-214M, 9-214ML

INTERMEDIATE FREQUENCY: AM Band:
455 kc. FM Band: 10.7 mc.

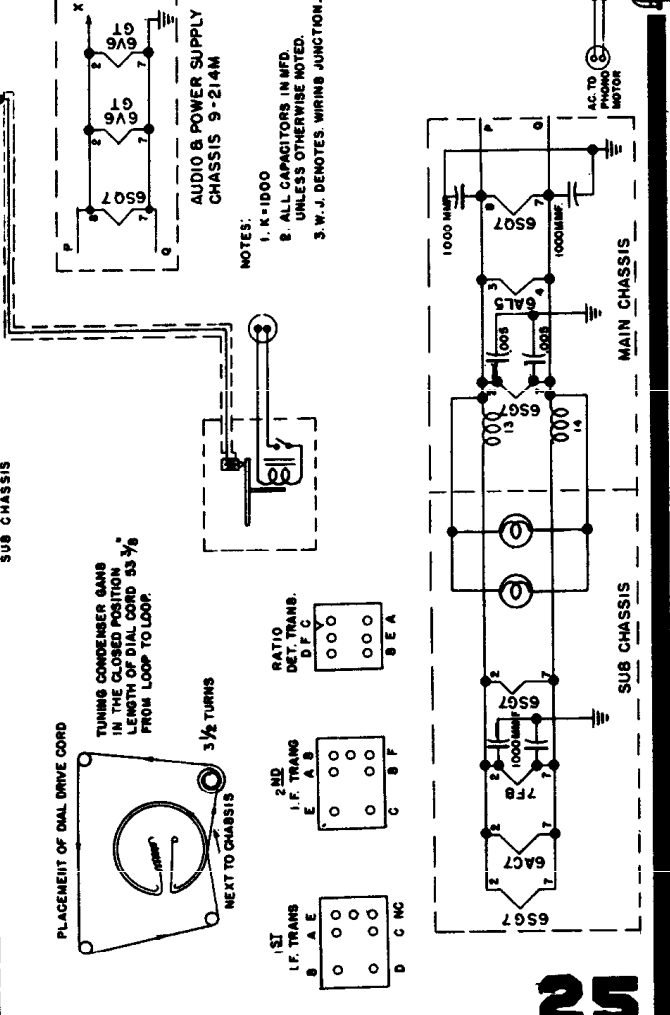
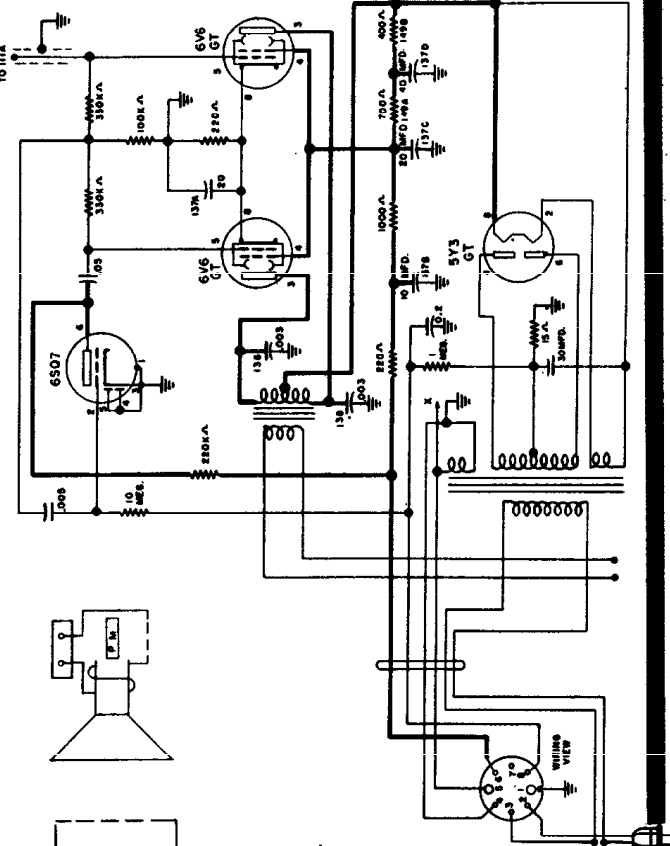
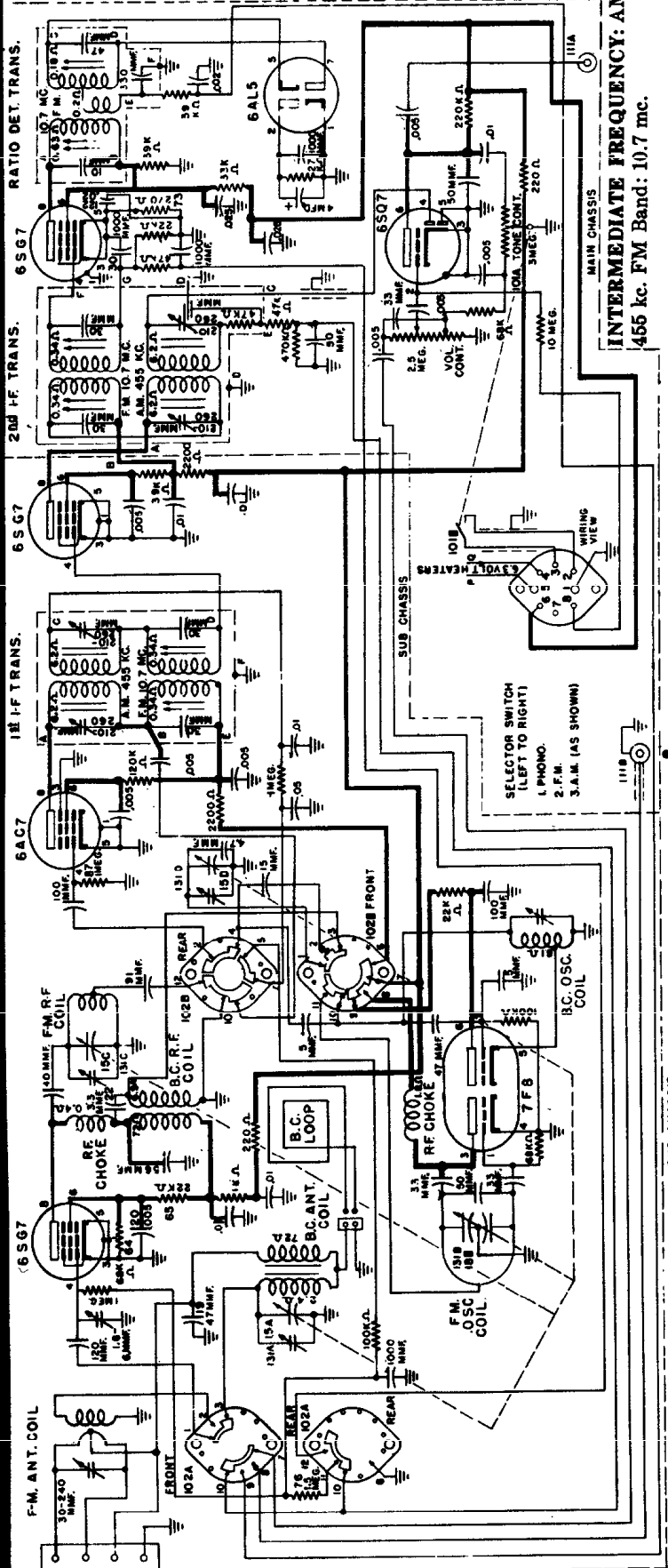

- NOTES:
- 1. K=1000
 - 2. ALL CAPACITORS IN MFD. UNLESS OTHERWISE NOTED.
 - 3. W.J. DENOTES WIRING JUNCTION.

1ST I.F. TRANS.	A	B	C	D	NC
2ND I.F. TRANS.	E	A	B	C	B
RATIO DET. TRANS.	D	F	C	B	E

CHASSIS, TOP VIEW



PLACEMENT OF DIAL DRIVE CORD
TUNING CONDENSER GANG IN
THE CLOSED POSITION.
LENGTH OF DIAL CORD 29 1/2"
FROM LOOP TO LOOP.

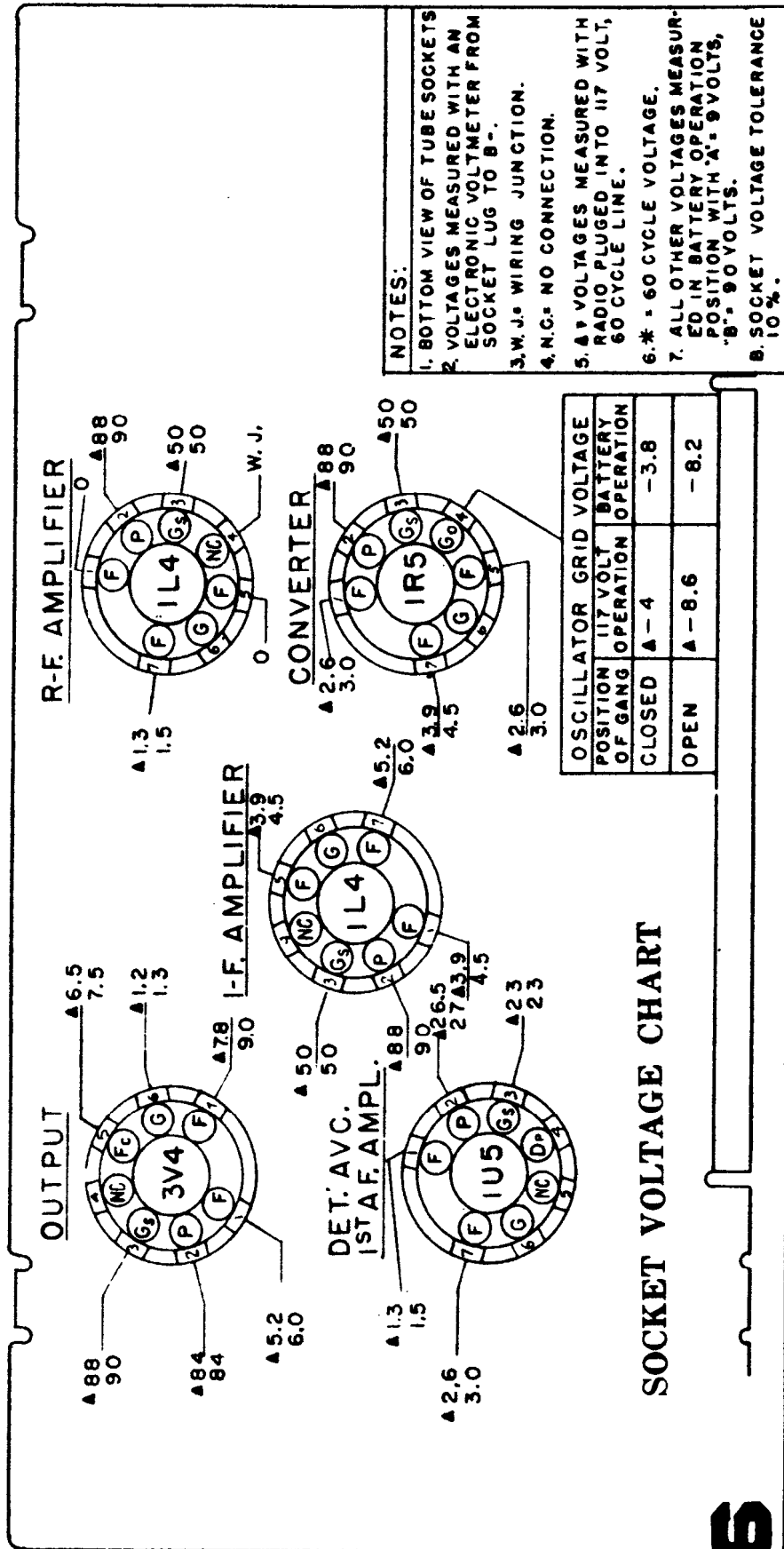

- NOTES:
1. BOTTOM VIEW OF TUBE SOCKETS
 2. VOLTAGES MEASURED WITH AN ELECTRONIC VOLTMETER FROM SOCKET LUG TO B-.
 3. W.J. = WIRING JUNCTION.
 4. N.C. = NO CONNECTION.
 5. Δ V VOLTAGES MEASURED WITH RADIO PLUGGED INTO 117 VOLT, 60 CYCLE LINE.
 6. * = 60 CYCLE VOLTAGE.
 7. ALL OTHER VOLTAGES MEASURED IN BATTERY OPERATION POSITION WITH 'A' = 9 VOLTS, 'B' = 90 VOLTS.
 8. SOCKET VOLTAGE TOLERANCE 10%.

OSCILLATOR GRID VOLTAGE POSITION 117 VOLT BATTERY OPERATION	
OF GANG	OPERATION
CLOSED	Δ - 4
OPEN	Δ - 8.6
	- 8.2

SOCKET VOLTAGE CHART

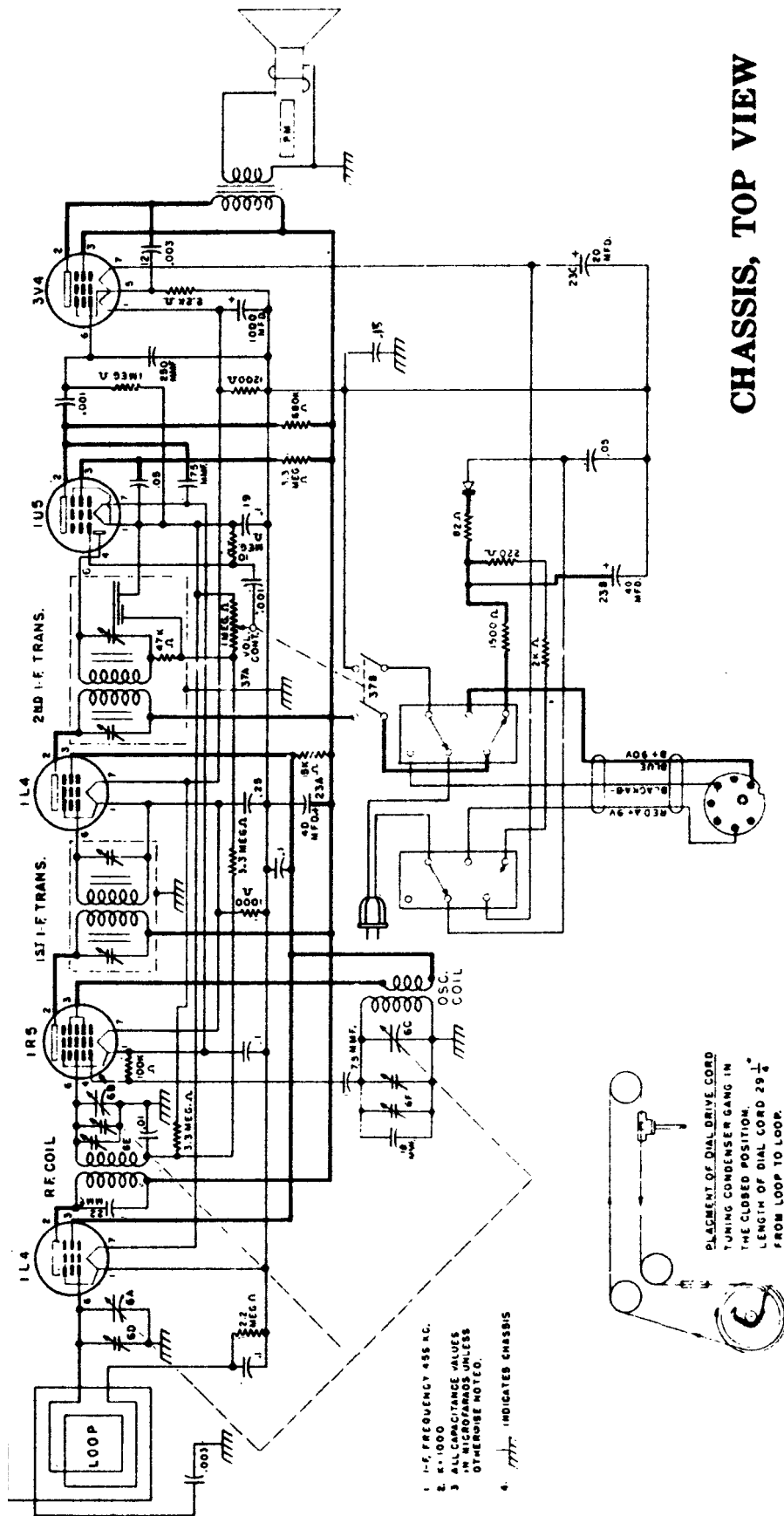

CHASSIS, TOP VIEW

- 1. I-F FREQUENCY 455 KC.
- 2. 50-1000.
- 3. ALL CAPACITANCE VALUES IN MICROFARADS UNLESS OTHERWISE NOTED.
- 4. INDICATES CHASSIS

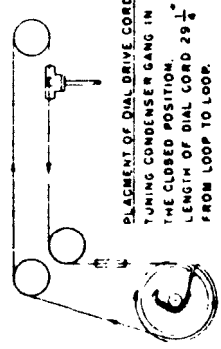

MANUAL OF 1949 MOST-OFTEN-NEEDED RADIO DIAGRAMS

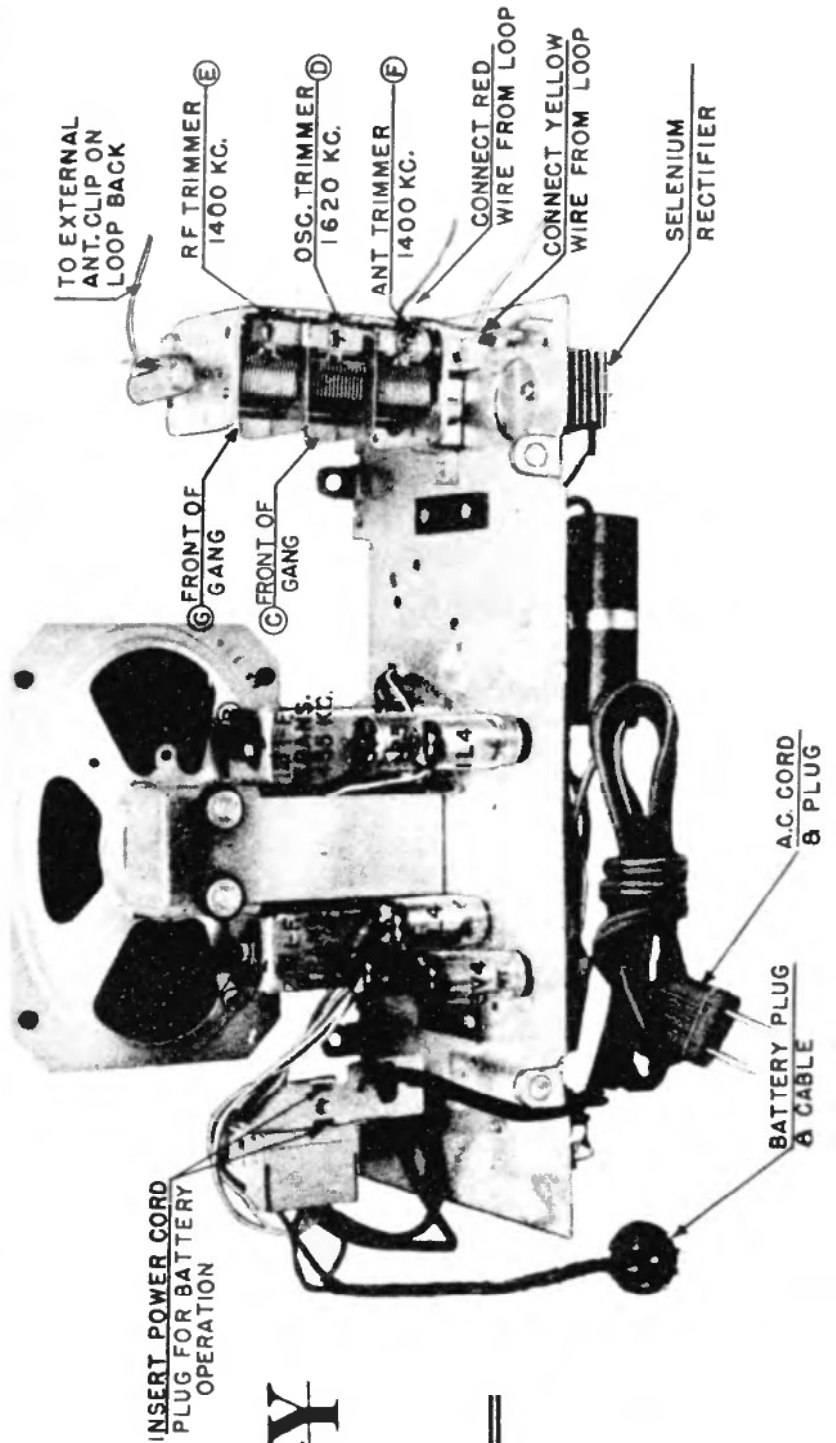

CROSLLEY

MODEL: 9-302

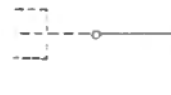

MANUAL OF 1949 MOST-OFTEN-NEEDED RADIO DIAGRAMS

DEWALD RADIO

MODELS - A500 - A501 - A502 - A503

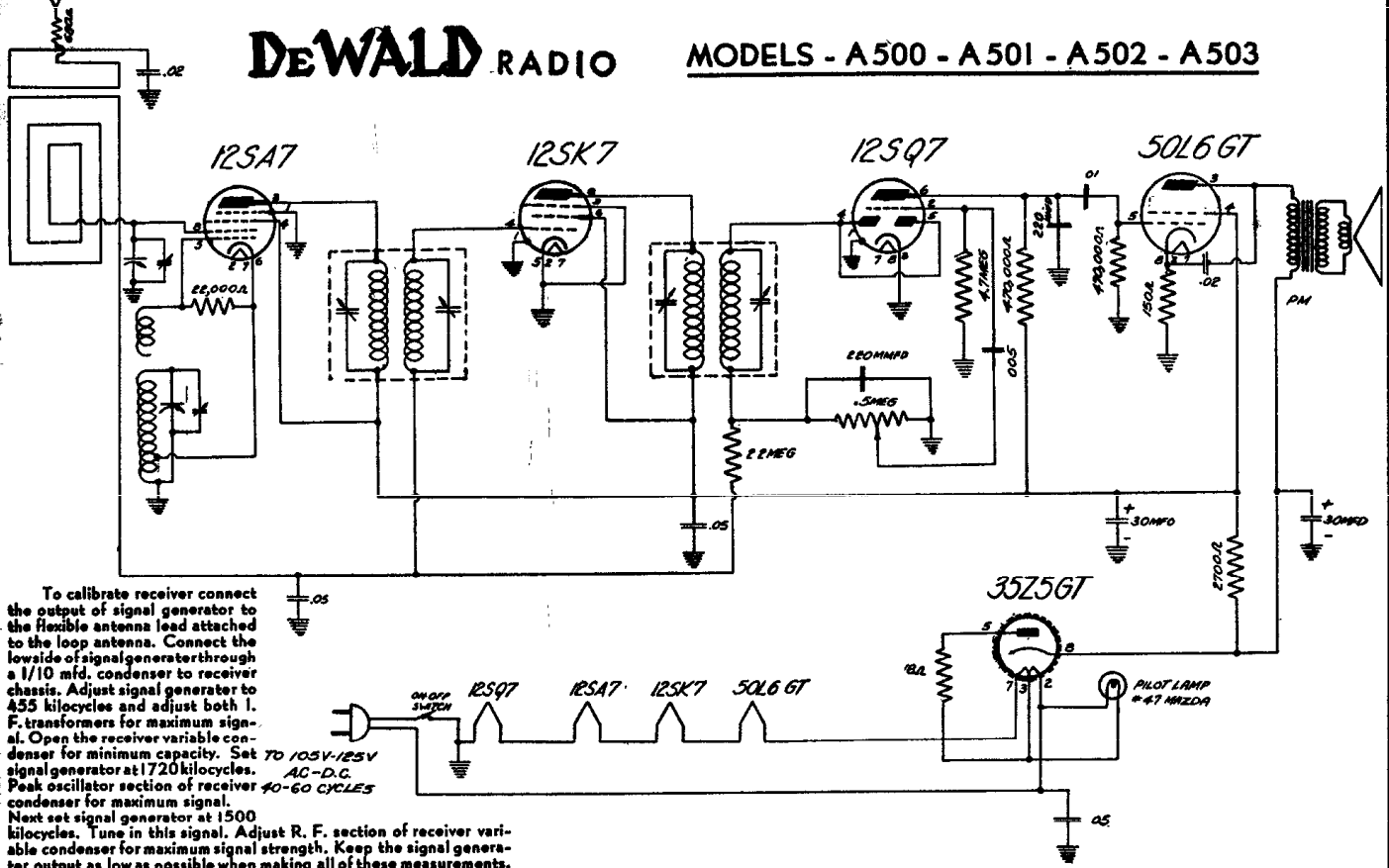

ANTENNA:

The receiver operates satisfactorily without an antenna. If additional pick-up is desired, an antenna may be connected to the lead, extending from the rear of the chassis.

VOLUME CONTROL:

The left knob of the receiver is used as the power switch and volume control. Rotation of this knob in a clockwise direction turns the receiver "on". Further rotation in this direction increases the volume.

STATION SELECTOR:

The right hand knob operates the tuning in of stations and pointer. Ease and accuracy in tuning is provided because of a reduction drive.

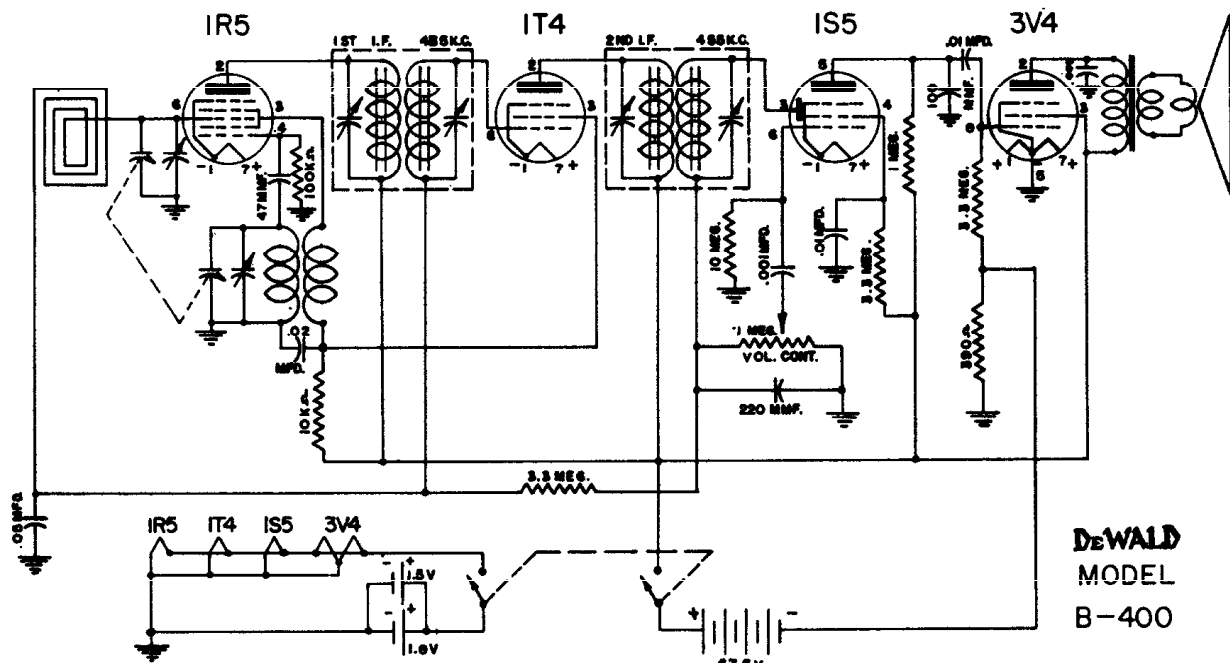

MANUAL OF 1949 MOST-OFTEN-NEEDED RADIO DIAGRAMS

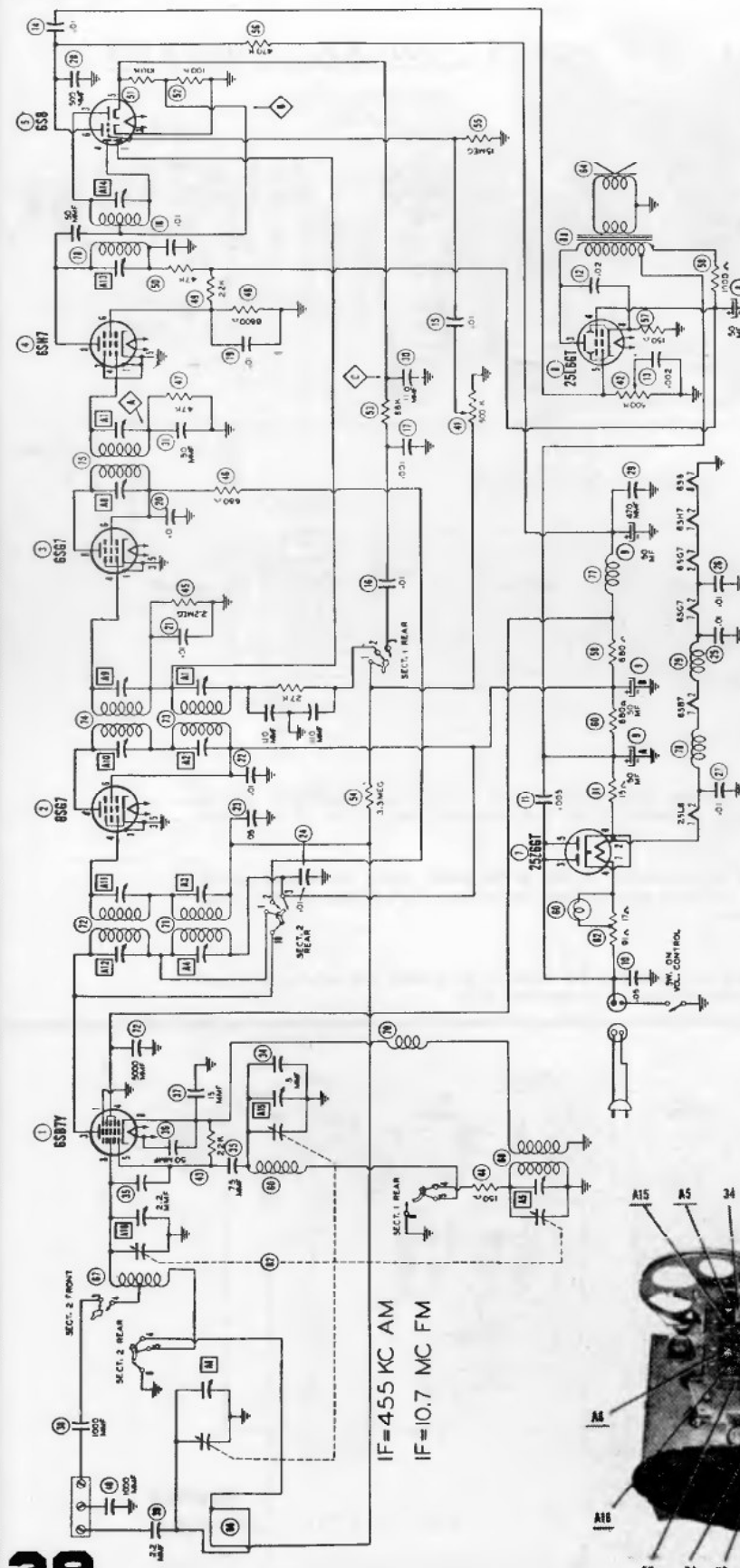

MODEL: 557 - 565
CHASSIS MODEL: 120048B

Emerson Radio

RESISTANCE READINGS

SYMBOL	TUBE	PIN 1	PIN 2	PIN 3	PIN 4	PIN 5	PIN 6	PIN 7	PIN 8
1	6SE7Y	0 ohm	22 ohm	30K ohm	31K ohm	22K ohm	.6 ohm	34 ohm	3.8 meg.
2	6SG7	0 ohm	17 ohm	0 ohm	3.8 meg.	0 ohm	30K ohm	21 ohm	30K ohm
3	6SG7	0 ohm	17 ohm	0 ohm	2.2 meg.	0 ohm	30K ohm	9 ohm	30K ohm
4	6SH7	0 ohm	3 ohm	0 ohm	47K ohm	0 ohm	7K ohm	9 ohm	77K ohm
5A	6S8GT	520K ohm	0 ohm	100K ohm	100K ohm	200K ohm	500K ohm	0 ohm	3 ohm
5B	6S8GT	Inf.	0 ohm	100K ohm	100K ohm	200K ohm	500K ohm	0 ohm	3 ohm
6	25L6GT	31K ohm	35 ohm	30K ohm	31K ohm	420K ohm	30K ohm	46 ohm	150 ohm
7	25Z6GT	30K ohm	46 ohm	175 ohm	30K ohm	175 ohm	30K ohm	65 ohm	30K ohm

† Taken in FM Position.
Socket connections are shown as bottom views.
Measured values are from socket pin to common negative.

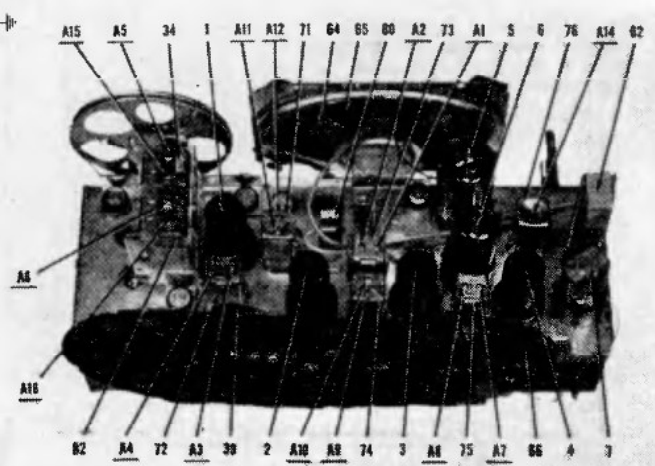

20 21 22 23 24 25

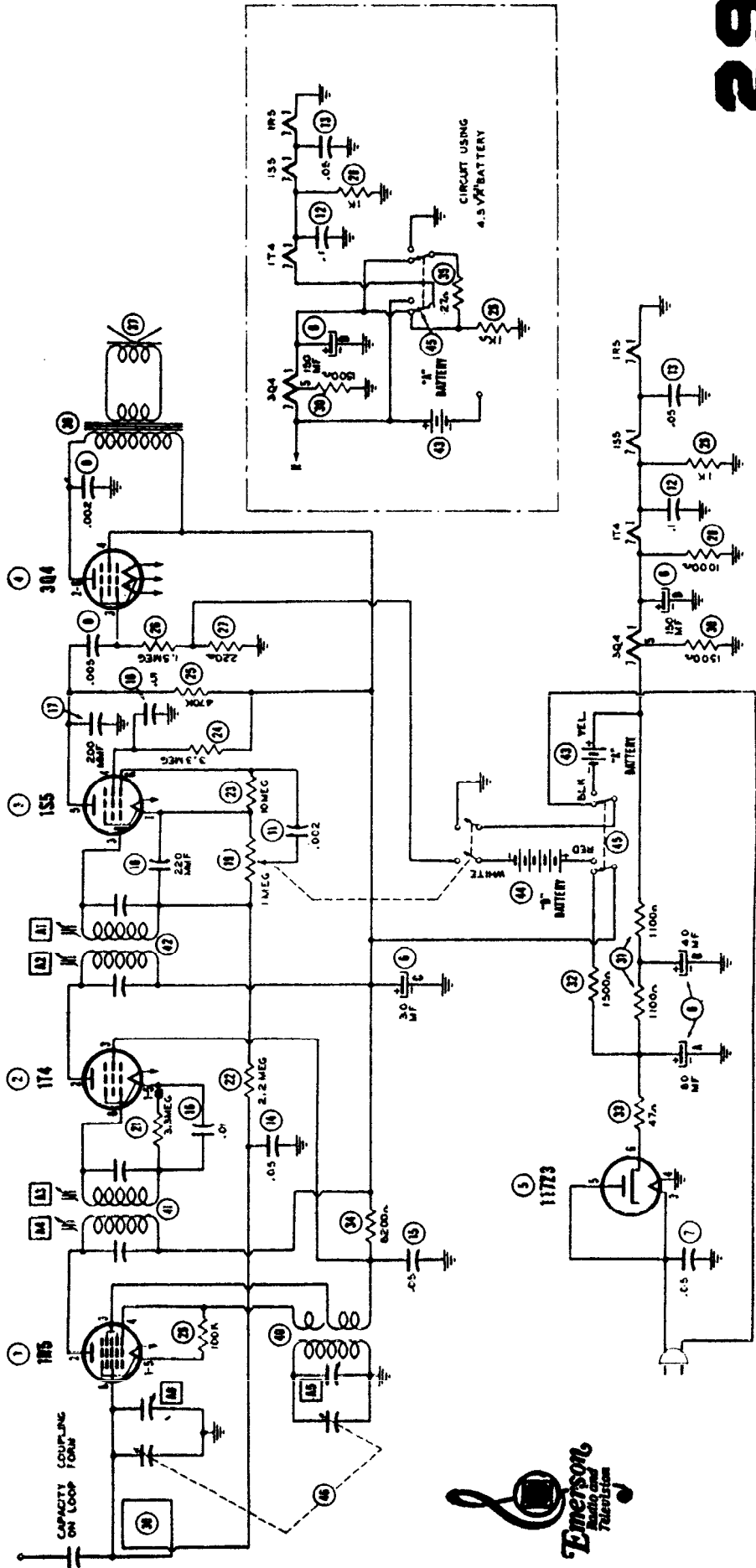

Oscillator Grid Voltages Are Measured By Vacuum-Tube Voltmeter.

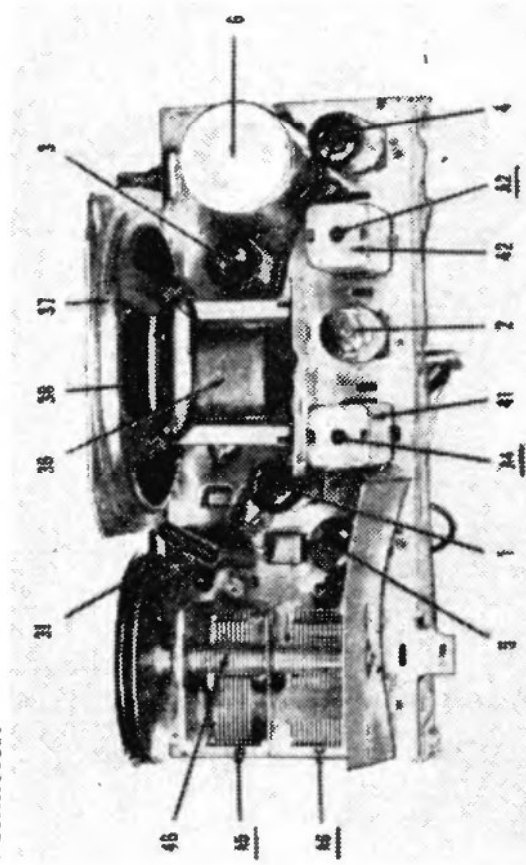
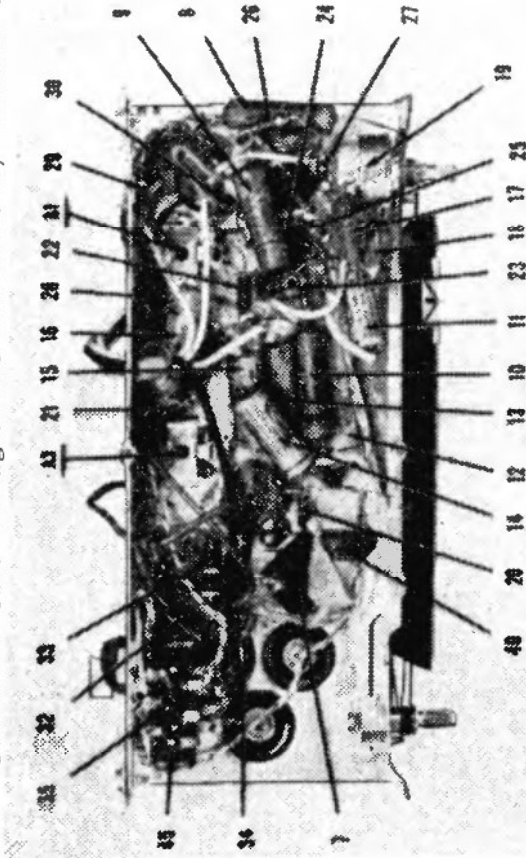

MANUAL OF 1949 MOST-OFTEN-NEEDED RADIO DIAGRAMS

EMERSON RADIO & PHONOGRAPH CORP.

MODEL: 559

CHASSIS MODEL: 120059

	DUMMY ANTENNA	SIGNAL GENERATOR COUPLING	SIGNAL GENERATOR FREQUENCY	RADIO DIAL SETTING	OUTPUT METER	ADJUST	REMARKS
1	0.1 mfd.	High side to rear stator of variable condenser. Low side to chassis.	455 kc	Variable condenser fully open.	Across voice coil.	A1, A2 A3, A4	Adjust for maximum output. If a-c power is used without an isolation transformer, reduce dummy antenna to 200 mmfd. to reduce hum modulation.
2		Loop	1620 kc	Variable condenser fully open.	Across voice coil.	A5	Fashion loop of several turns of wire and radiate signal into loop of receiver. Adjust for maximum output.
3		Loop	1400 kc	Tune for maximum	Across voice coil.	A6	Adjust for maximum output.

1—Voltage and resistance readings taken in a.c.-d.c. position.

2—Voltage readings are in volts and resistance readings in ohms unless otherwise specified.

3—D-C voltage measurements are at 20,000 ohms per volt; a-c voltages measured at 1000 ohms per volt.

4—Socket connections are shown as bottom views.

5—Measured values are from socket pin to common negative.

SYMBOL	TUBE TYPE	PIN 1	PIN 2	PIN 3	PIN 4	PIN 5	PIN 6	PIN 7
1	1R5	0	90DC	62DC	—14.8DC	0	0	1.4DC
2	1T4	2.7D.C.	90DC	62DC	0	2.7DC	0.1DC	4.2DC
3	1S5	1.4DC	0	0.1DC	16DC	28.5DC	0	2.7DC
4	3Q4	4.2DC	85DC	0	90DC	5.6DC	85DC	7DC
5	117Z3	0	106DC	117AC	0	117AC	117DC	106DC

† Oscillator Grid Voltages Are Measured By Vacuum-Tube Voltmeter.

MANUAL OF 1949 MOST-OFTEN-NEEDED RADIO DIAGRAMS

EMERSON RADIO

MODELS: 570 - 574 - 580

CHASSIS MODEL: 120064

Schematic Symbol	†Part No.	DESCRIPTION
C1, C2	900022	Two-gang variable condenser
*C3	Part of C1	Trimmer
*C4	Part of C2	Trimmer
*C5, C6	Part of T1	Trimmer
*C7, C8	Part of T2	Trimmer
C9	928013	0.0001 mfd. ceramic condenser
C10	920497	0.001 mfd., 200 volt condenser
C11	920496	0.005 mfd., 200 volt condenser
C12	928104	212 mmfd., ceramic condenser
C13	920497	0.001 mfd., 200 volt condenser
C14	928010	0.0001 mfd., ceramic condenser (Alternate part 928013)
C15	920494	0.05 mfd., 200 volt condenser
C16	920120	0.02 mfd., 100 volt condenser
C17	925063	16 mfd., 100 volt electrolytic condenser
C18	920485	0.01 mfd., 100 volt condenser
L1	700019	Loop antenna
L2	708007	Loading coil
R1	340970	100,00 ohms, ½ watt resistor
R2	340470	820 ohms, ½ watt resistor
R3	390025	1 meg., volume control
R4	351450	10 meg., ½ watt resistor
R5	351330	3.3 meg., ½ watt resistor
R6	351130	470,000 ohms, ½ watt resistor
R7	351250	1.5 meg., ½ watt resistor
R8	340730	10,000 ohms, ½ watt resistor
R9	351330	3.3 meg., ½ watt resistor

The following voltage readings are d-c measurements taken from B— (chassis) to the indicated tube-socket pin. A 1000 ohms-per-volt meter should be used for all readings except those indicated by an asterisk (*), which should be taken with a d-c vacuum-tube voltmeter. Take readings with the volume control set at minimum and the variable condenser closed. Use fresh batteries.

TUBE	PIN NUMBER						
	1	2	3	4	5	6	7
1R5		60	35	*-8		*-0.2	1.5
1T4		60	35			*-0.2	1.5
1S5			*-0.2	*17	*25	*-0.1	1.5
3S4	1.5	59	*-6.5	60		59	1.5

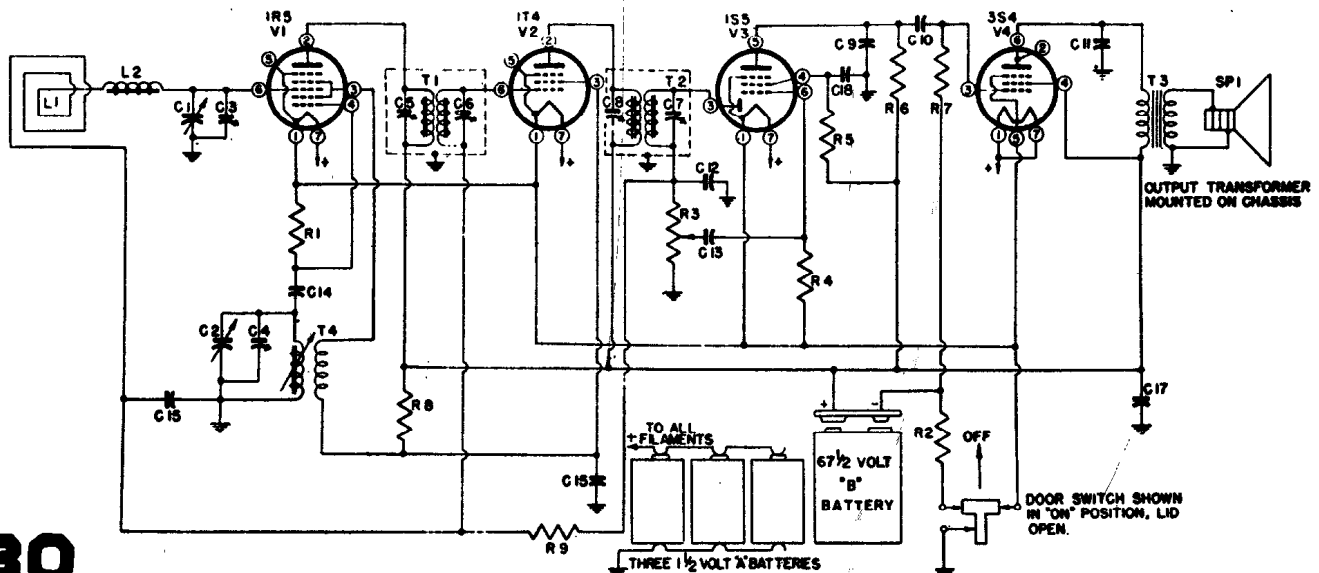

I-f Alignment

1. Rotate the variable condenser to the minimum capacity position.
2. Feed 455 kc to the grid (pin 6) of the 1R5 tube through a 0.01 mfd. condenser.
3. Adjust the four i-f trimmer screws for maximum response. (Clip the test signal lead to the stator of the larger capacity section of the variable condenser.)

R-f Alignment

1. Connect the test oscillator to a coil composed of three or four turns of wire wound in a circle approximately 12 inches in diameter. This coil should be placed parallel to and in line with the receiver loop at a distance of approximately 15 to 20 inches.
2. Radiate a signal at 1620 kc, rotate the variable condenser to minimum capacity, and adjust the oscillator trimmer, on the smaller section of the variable condenser, for maximum response.
3. Radiate a signal at 1420 kc, tune in the 1420 kc signal, end adjust the antenna trimmer, on the larger section of the variable condenser, for maximum response.
4. Radiate a signal at 600 kc, set the dial indicator to 60, and adjust the oscillator coil core trimmer while rocking the variable condenser for maximum response.
5. Return to 1620 kc and check alignment. If readjustment is necessary, repeat Steps 2 to 4 until no further improvement is noted.

MANUAL OF

EMERSON RADIO

MODEL: 577

CHASSIS MODEL: 120012B

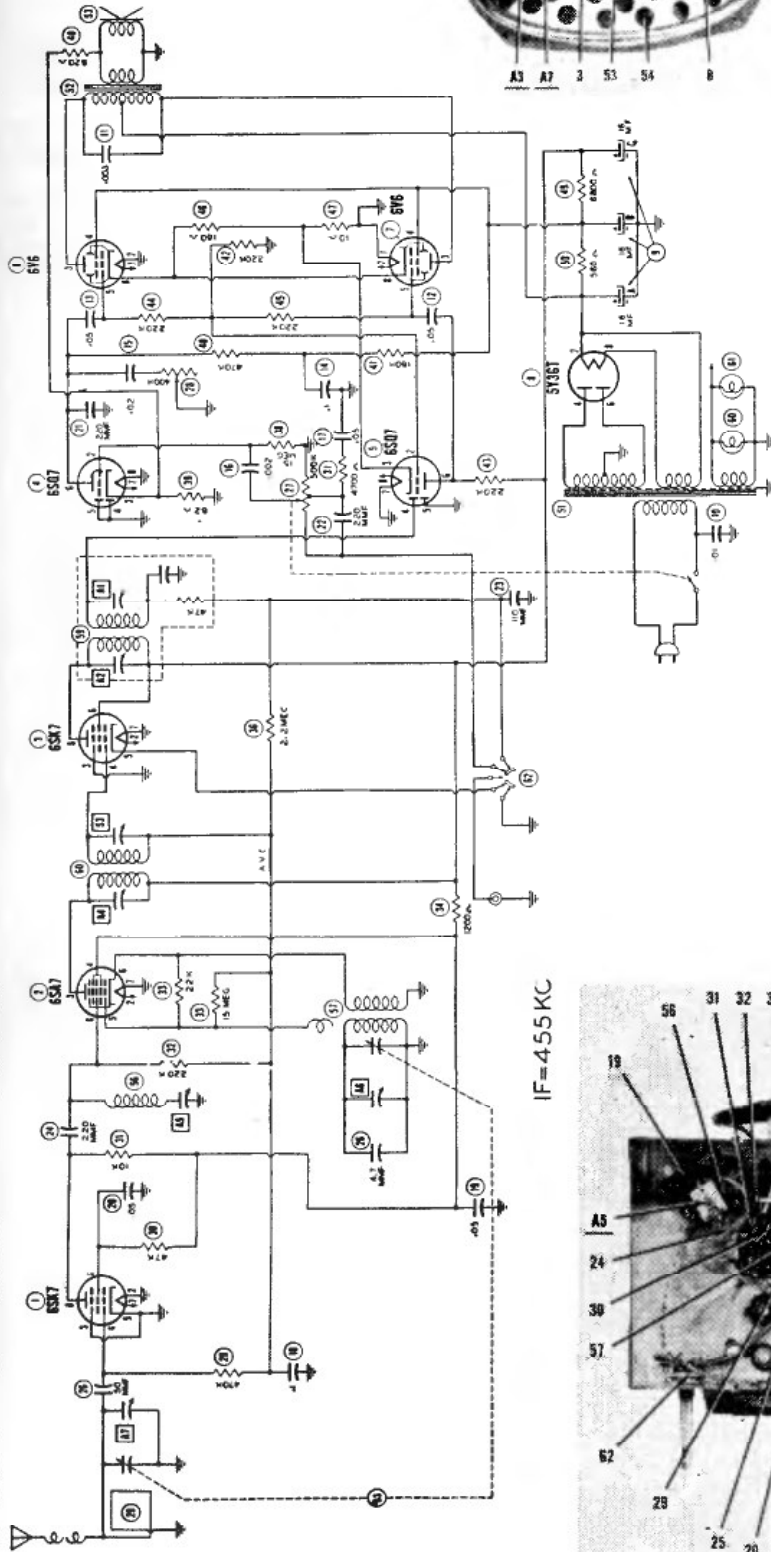
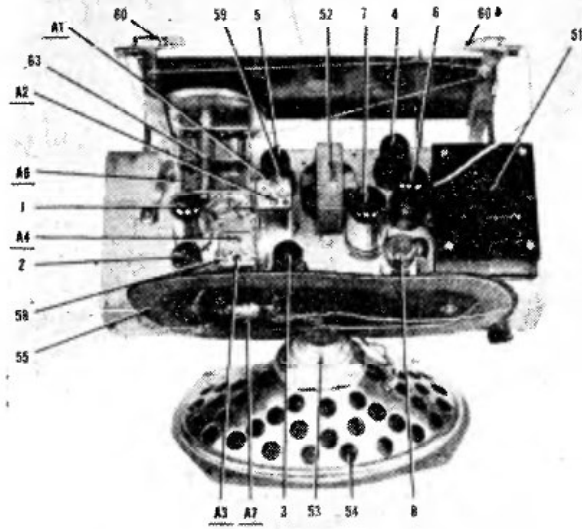

For Alignment set volume control in maximum position; signal generator output just high enough to obtain reading.

IF=455 KC

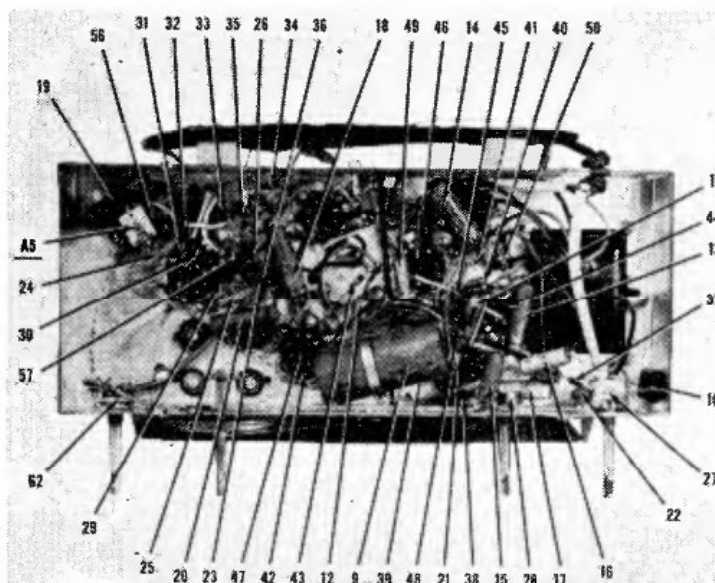

RADIO DIAGRAMS

	DUMMY ANTENNA	SIGNAL GENERATOR COUPLING	SIGNAL GENERATOR FREQUENCY	RADIO DIAL SETTING	OUTPUT METER	ADJUST	REMARKS
1	.1 mfd.	High side to Pin 8 (grid) of 6SA7. Low side to chassis.	455KC	Tuning cap. fully open.	Across voice coil.	A1, A2, A3, A4	Adjust for maximum output.
2	200 mmf.	High side to ext. ant. lead. Low side to chassis.	"	Tuning cap. fully closed.	"	A5	Adjust for minimum output.
3	200 mmf.	"	1620KC	Tuning cap. fully open.	"	A6	Adjust for maximum output
4	200 mmf.	"	1400KC	Tune for maximum output.	"	A7	" " "
5	200 mmf.	"	600KC	"	"		Adjust outside turn of loop for maximum output.

MODEL 583 SCHEMATIC SIMILAR EXCEPT TUNING EYE IS OMITTED

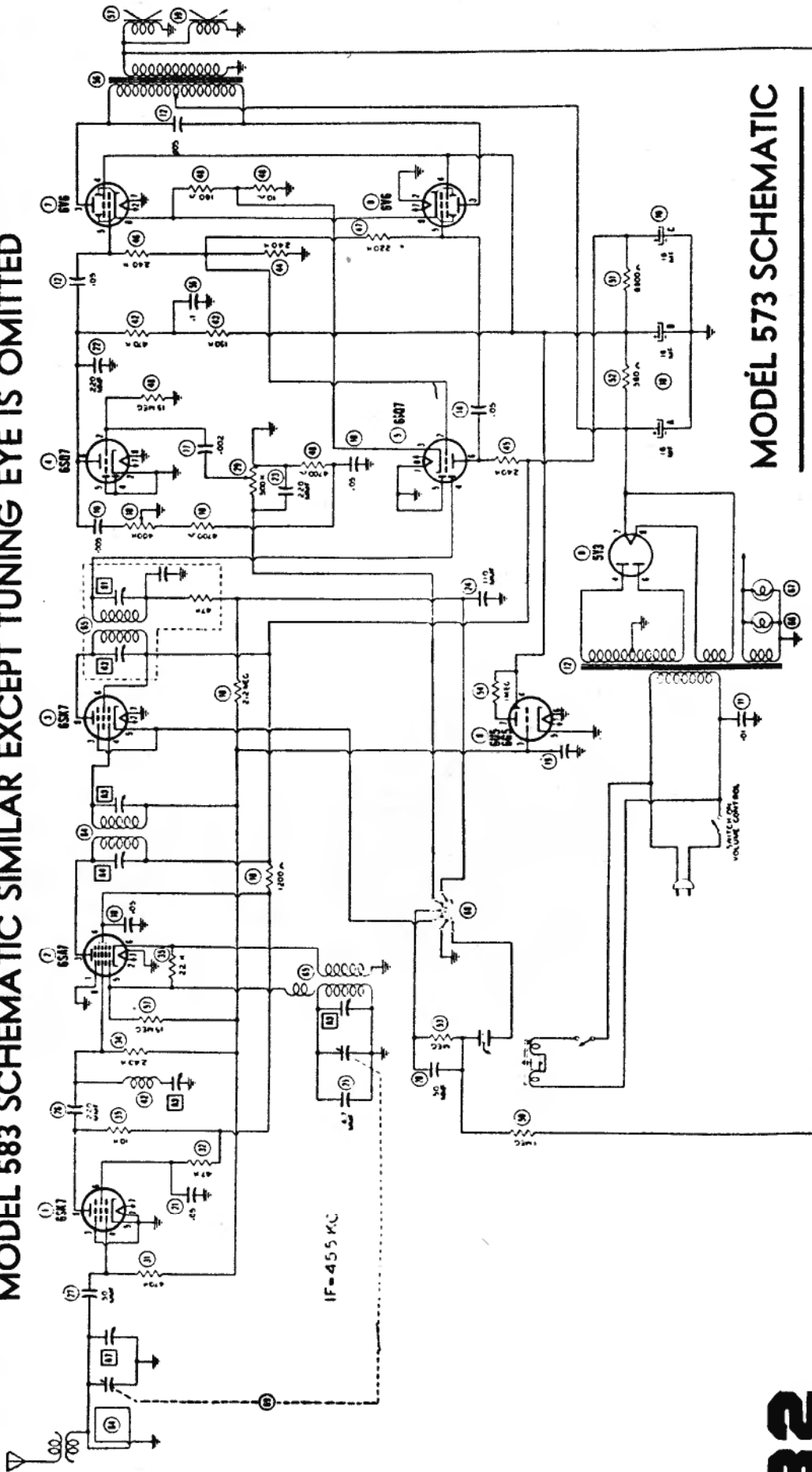

MODEL 573 SCHEMATIC

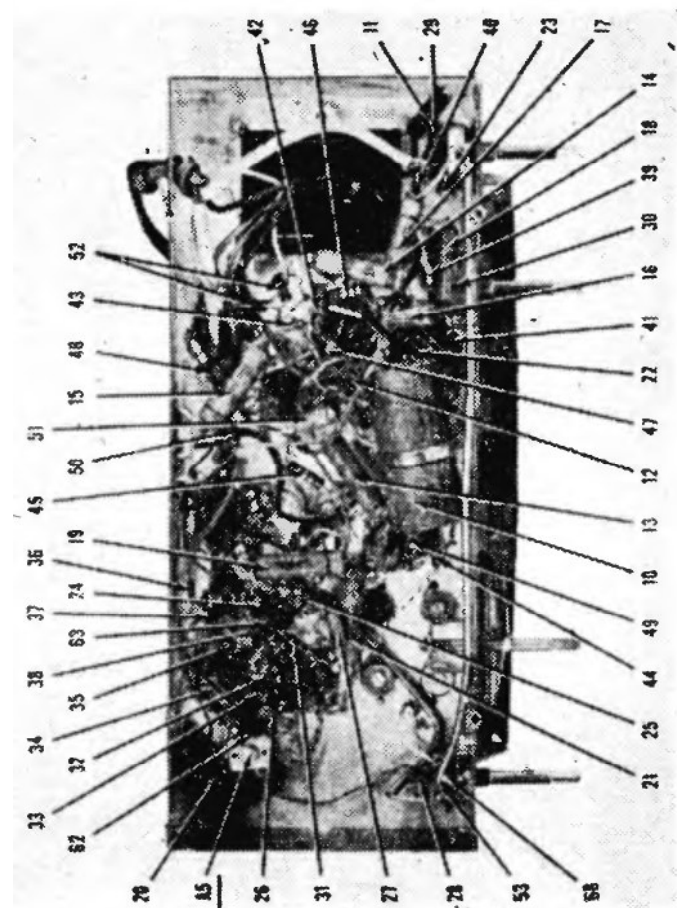
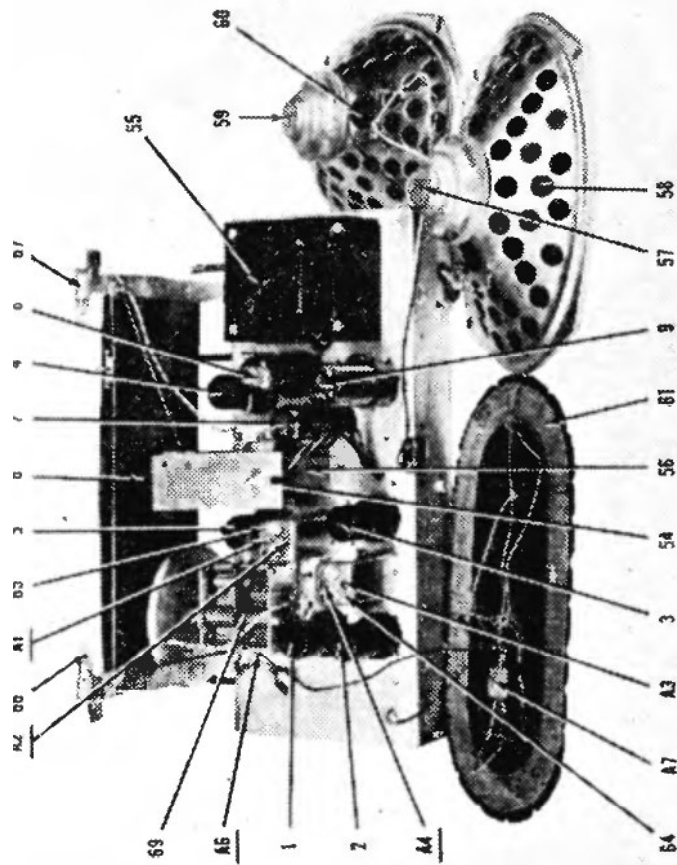

MANUAL OF 1949 MOST-OFTEN-NEEDED RADIO DIAGRAMS

Emerson Radio Models 573, 583, Chassis 120039B, Alignment

To set pointer, turn tuning cap. fully closed and set pointer 2-3/8" from left edge of dial backplate. This is the calibration mark referred to below.

Loop should be maintained in same relative position to chassis as when receiver is in cabinet.

Volume control should be at maximum position; output signal generator should be no higher than necessary to obtain an output reading. Use an insulated alignment screwdriver for adjusting.

	DUMMY ANTENNA	SIGNAL GENERATOR COUPLING	SIGNAL GENERATOR FREQUENCY	RADIO DIAL SETTING	OUTPUT METER	ADJUST	REMARKS
1	.1 mfd.	High side to pin 8 (grid) of 6SA7. Low side to chassis.	455KC	Tuning cap. fully open.	Across voice coil.	A1, A2, A3, A4	Adjust for maximum output.
2	.1 mfd.	High side to ext. antenne lead. Low side to chassis.	"	Tuning cap. fully closed.	"	A5	Adjust for minimum output.
3	200 mmf.	"	1400KC	5" from calibration mark.	"	A6	Adjust for maximum output.
4	200 mmf.	"	"	Tune for maximum output.	"	A7	Adjust for maximum output.
5	200 mmf.	"	600KC	"	"		Use adjusting turn in rear of loop. Adjust for max. output.

MANUAL OF 1949 MOST-OFTEN-NEEDED RADIO DIAGRAMS

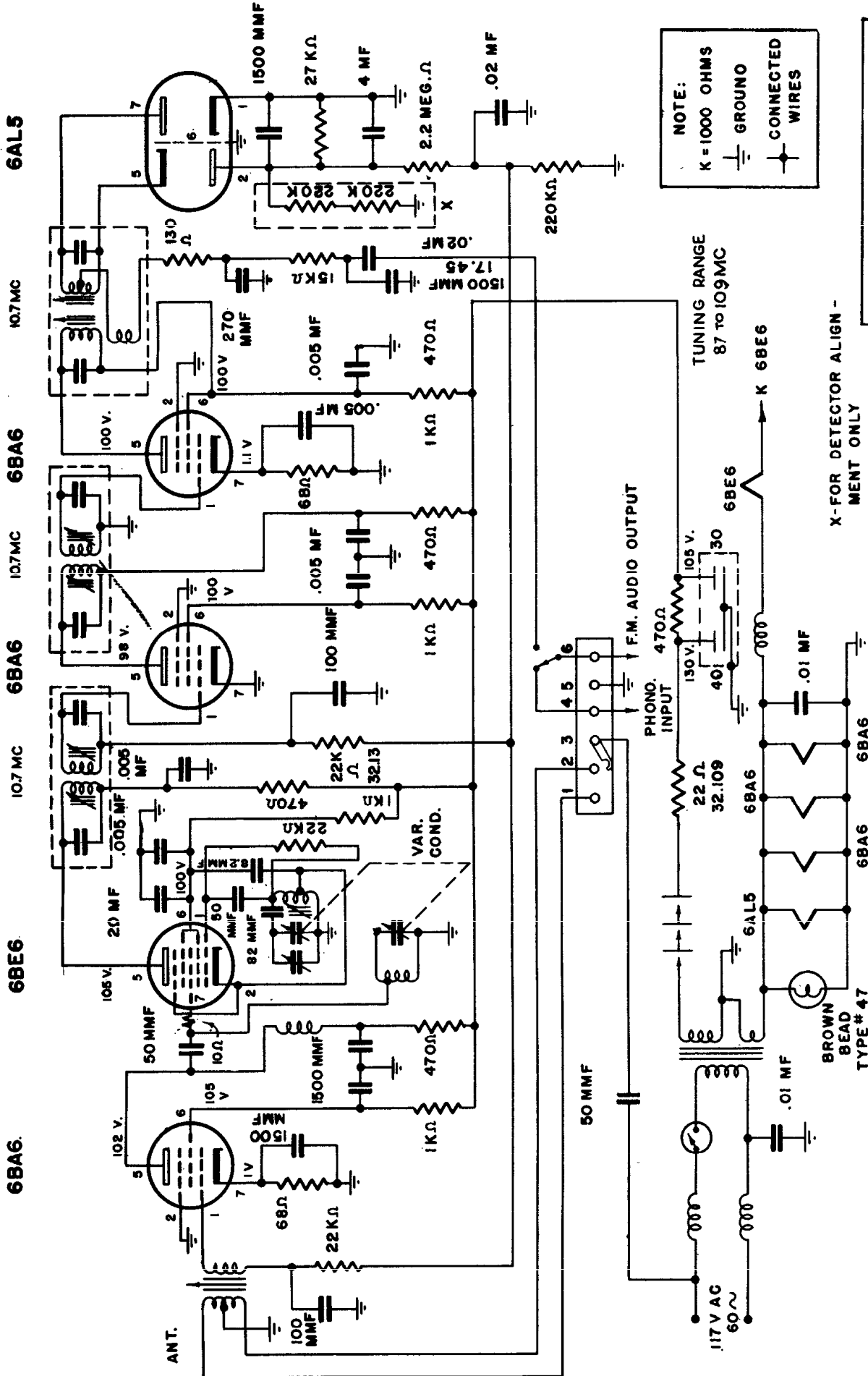

MODEL 795
 SCHEMATIC
 FADA RADIO & ELECTRIC CO., INC.
 BELLEVILLE, NEW JERSEY U.S.A.

795 SERIES

5 Tube AC Superheterodyne FM Tuner



MANUAL OF 1949 MOST-OFTEN-NEEDED RADIO DIAGRAMS

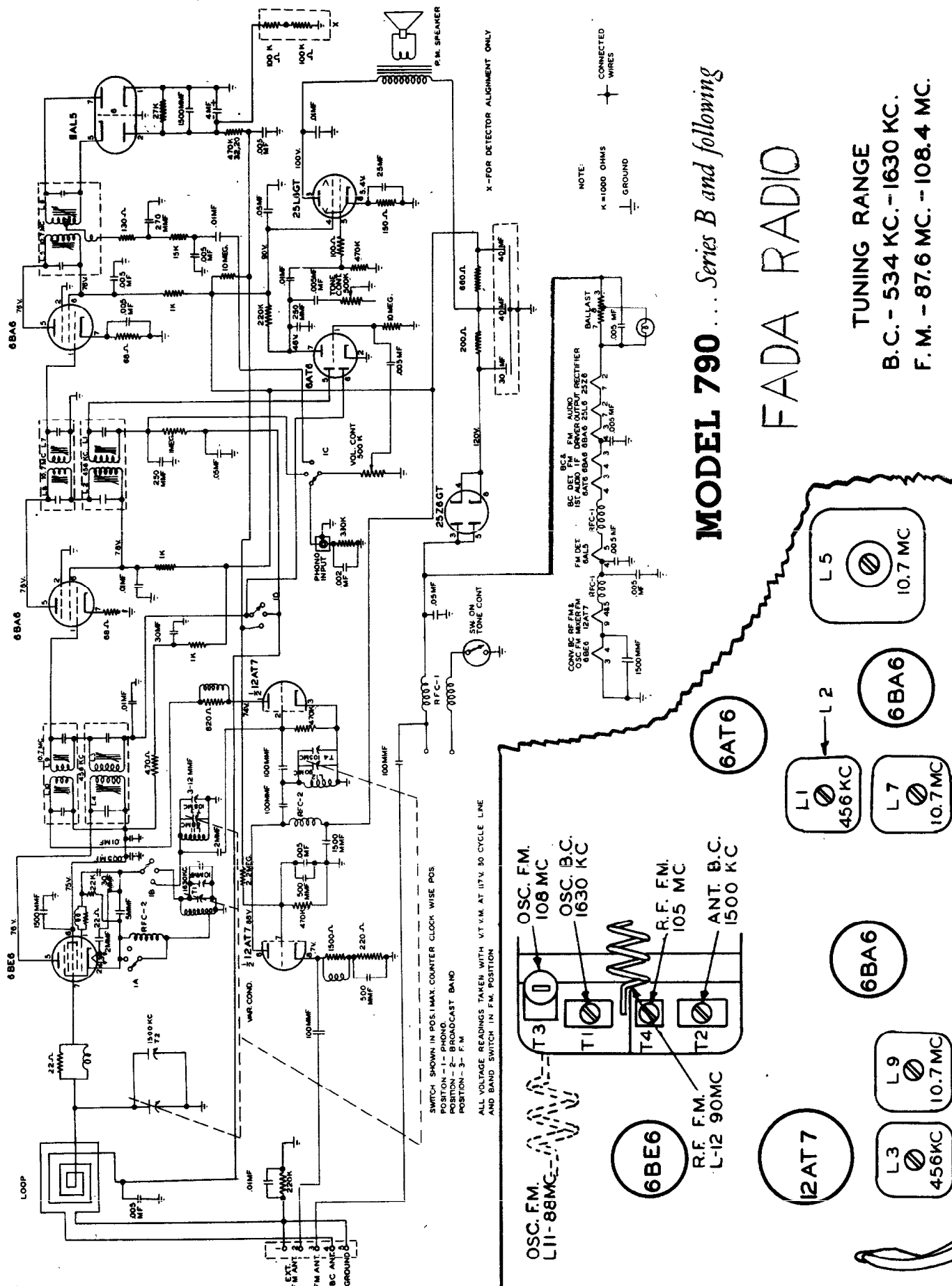

MANUAL OF 1949 MOST-OFTEN-NEEDED RADIO DIAGRAMS

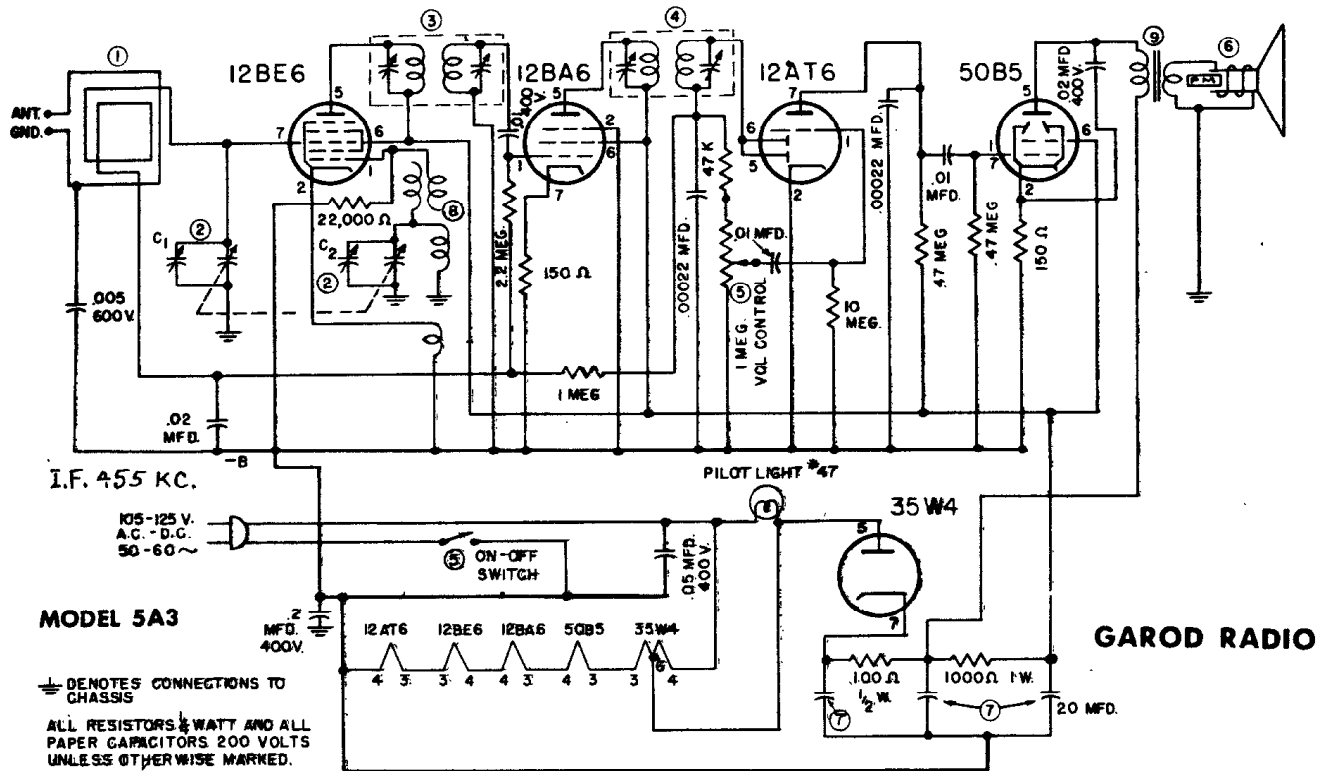

MODEL 5A3

GAROD RADIO

⊥ DENOTES CONNECTIONS TO CHASSIS
 ALL RESISTORS 1/2 WATT AND ALL PAPER CAPACITORS 200 VOLTS UNLESS OTHERWISE MARKED.

- ① 1.464 LOOP ANTENNA
- ② 2.213 2 GANG VARIABLE COND.
- ③ 1.259 1ST I.F. TRANSFORMER
- ④ 1.409 2ND I.F. TRANSFORMER
- ⑤ 8.200-1 VOLUME CONTROL & SWITCH
- ⑥ 30.300 P.M. SPEAKER
- ⑦ 5.415-1 ELECTROLYTIC CAP. 40-40-20MFD.
- ⑧ 1.402-1 OSCILLATOR COIL

MODEL **5A3**

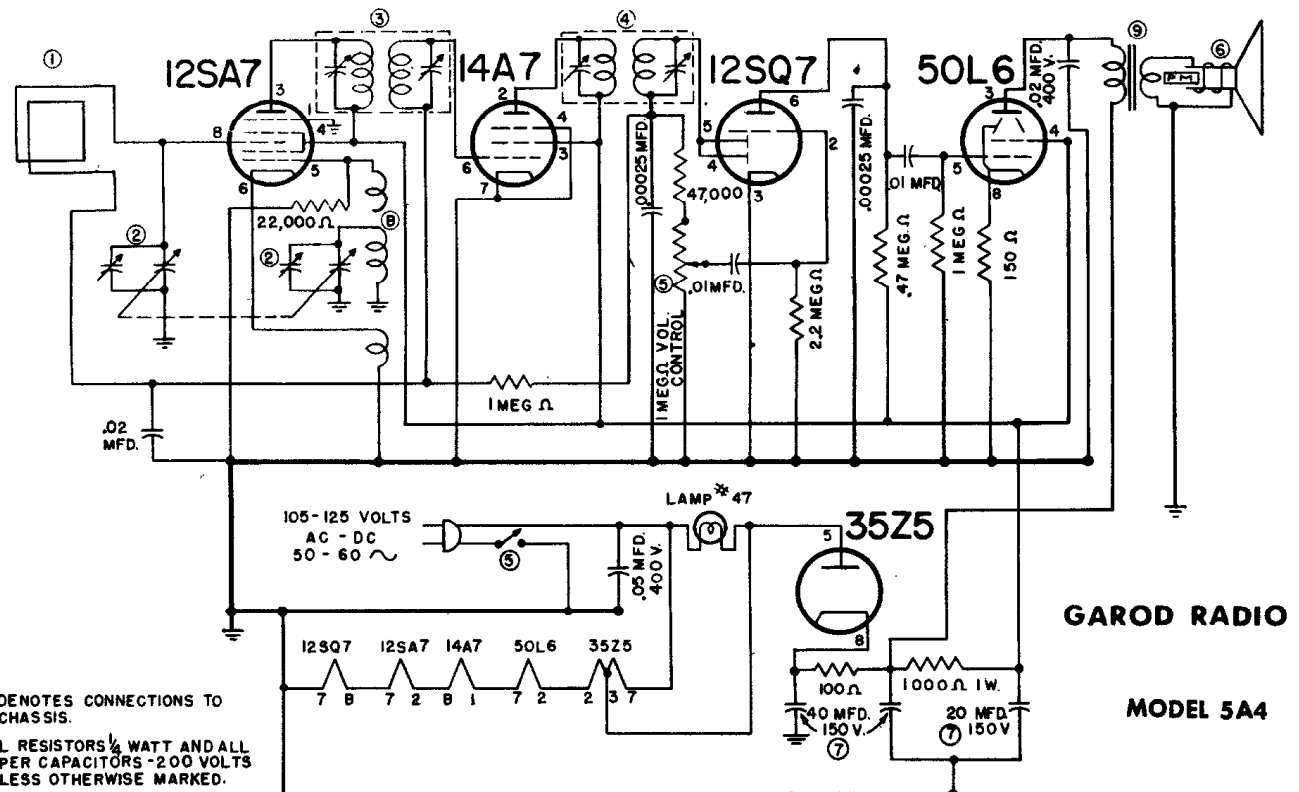

GAROD RADIO

MODEL 5A4

⊥ DENOTES CONNECTIONS TO CHASSIS.
 ALL RESISTORS 1/2 WATT AND ALL PAPER CAPACITORS 200 VOLTS UNLESS OTHERWISE MARKED.

- ① 1.469 LOOP ASSEMBLY
- ② 2.163 2GANG VARIABLE COND.
- ③ 1.259 1ST I.F. TRANSFORMER
- ④ 1.409 2ND I.F. TRANSFORMER
- ⑤ 8.201-3 VOLUME CONTROL & SWITCH
- ⑥ 30.318 P.M. 5" SPEAKER
- ⑦ 5.400-8 ELECTROLYTIC CAP. 40-40-20MFD.
- ⑧ 1.402-1 OSCILLATOR COIL
- ⑨ 9.219 OUTPUT TRANSFORMER

I.F. = 455 K.C.

35

MANUAL OF 1949 MOST-OFTEN-NEEDED RADIO DIAGRAMS

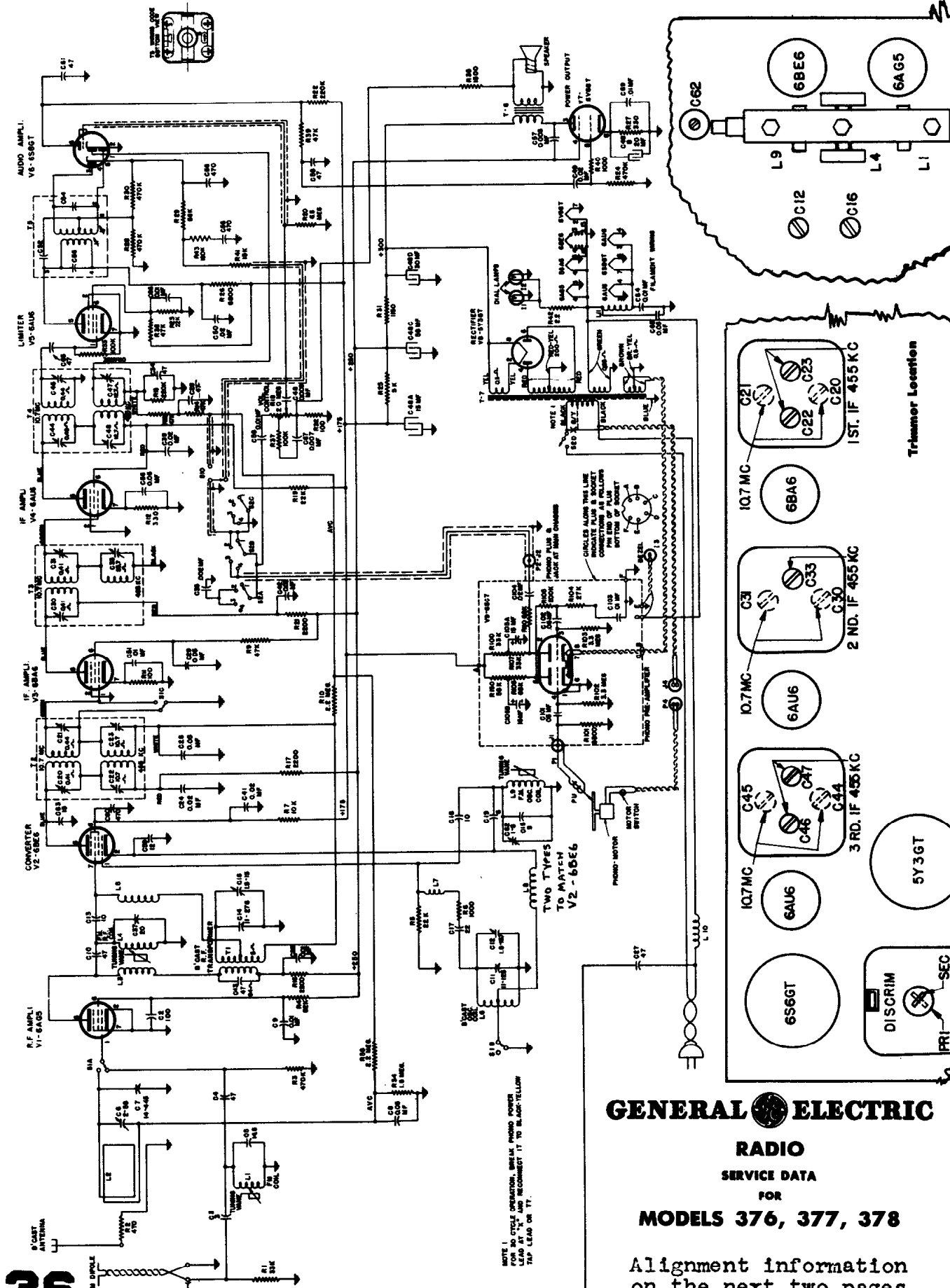

36

NOTE: IN CYCLE OPERATION, BREAK PHONO POWER LEAD AT T₁ AND RECONNECT IT TO BLACK-YELLOW TAP LEAD ON T₁.

GENERAL ELECTRIC

RADIO
SERVICE DATA
FOR

MODELS 376, 377, 378

Alignment information on the next two pages.

MANUAL OF 1949 MOST-OFTEN-NEEDED RADIO DIAGRAMS

General-Electric Models 376, 377, 378, Alignment Information

NOTES IN CONNECTION WITH METER ALIGNMENT:

- (1) Use unmodulated signal.
- (2) Connect 20,000 ohm-per-volt meter from junction of R29 and R41.
- (3) Connect 20,000 ohm-per-volt meter from grid pin 1 of (V5) 6AU6 limiter to chassis with a 200,000-ohm resistor in series. The resistor must be connected directly to the grid to minimize capacity loading and to isolate the meter from the i-f voltage. Keep signal generator output down so that meter indicates not more than one volt at the grid (5 microamperes through 200,000 ohms) (Alignment Steps 7 through 13).
- (4) Use 400-cycle modulation (Steps 1, 2, 3, 15, 16, 17, and 18).
- (5) Connect a standard output-meter across speaker voice coil. Turn volume control full on. Keep signal generator output down so that meter indicates not more than $\frac{1}{2}$ watt output (1.26 volts) during alignment. (Steps 1, 2, 3, 15, 16, 17 and 18.)
- (6) Two oscillator settings will give response. The higher frequency response is the correct one; the other is the image response. If in doubt, start with the trimmer screw loosened completely and adjust for the first response.

(7) For alignment of the standard band oscillator and r-f trimmers, the input signal should be inductively coupled to the radio loop antenna by connecting a 4-turn, 6-inch diameter loop of bell wire across the signal generator terminals, and then locate the loop about one foot from the radio loop antenna to prevent possible errors in peak readings. The position of the loop in respect to the radio loop antenna should not be changed during any one set of adjustments. Steps 15, 16, 17 and 18.

(8) The lead from the signal generator must be kept as short as possible and it must be kept away from later stages to prevent regeneration. The signal may also be fed in to the tube pin connection from the top of the chassis to prevent regeneration.

(9) A dummy antenna is a resistor in series with the hot lead of the signal generator. The resistance of the resistor plus the termination impedance of the signal generator should equal 300 ohms.

(10) If a dial scale is not available, index the dial pointer as follows: Turn the pointer to the left-hand limit of travel and mark the dial plate at a reference edge of the pointer slide. Then set the pointer by turning the dial knob until the indicated dimension exists between the reference edge and the mark.

ALIGNMENT CHART

STEP	SIGNAL GEN-ERATOR FRE-QUENCY	SIGNAL INPUT POINT	BAND SWITCH	DIAL SETTING	ADJUST	SEE NOTE	REMARKS
AM I-F METER ALIGNMENT							
1	455 kc	Conv. grid directly thru .01 mfd	STD	Peak C47 and C46	4, 5	Adjust for max.
2	455 kc	Conv. grid directly thru .01 mfd	STD	Peak C33	4, 5	Adjust for max.
3	455 kc	Conv. grid directly thru .01 mfd	STD	Peak C23 and C22	4, 5	Adjust for max.
FM DISCRIMINATOR AND I-F METER ALIGNMENT							
4	10.7 mc	Pin 1 of V5 (6AU6) thru .01 mf	FM	Discrim. Secondary for zero meter	1, 2	Apply 1 volt signal input.
5	Detune sig-nal generator	Pin 1 of V5 (6AU6) thru .01 mf	FM	*Signal Generator	1, 2	*Detune signal generator to point of maximum meter reading.
6	As in Step 5	Pin 1 of V5 (6AU6) thru .01 mf	FM	Peak discr. primary	1, 2	Adjust for max.
7	10.7 mc	Pin 1 of V4 (6AU6) thru .01 mf	FM	Peak C45 and C44	1, 3	Adjust for max.
8	10.7 mc	Pin 1 of V3 (6BA6) thru .01 mf	FM	C31 and C30	1, 3	Adjust for max.
9	10.7 mc	Pin 7 of V2 (6BE6) thru .01 mf	FM	C21 and C20	1, 3, 8	Adjust for max.
FM R-F METER ALIGNMENT							
10	98 mc	Dipole terminals thru dummy antenna	FM	98 mc or $3\frac{1}{8}$ inches	Peak C62	1, 3, 6, 9, 10	
11	98 mc	Dipole terminals thru dummy antenna	FM	For max. output	Peak L4 vane	1, 3, 9	
12	Repeat steps 10 and 11 until no further improvement in sensitivity.						
13	98 mc	Dipole terminals thru dummy antenna	FM	98 mc	Peak L1 vane	1, 3, 9	
14	Repeat steps 10, 11, and 12.						
AM R-F METER ALIGNMENT							
15	1500 kc	Inductively coupled	STD	1500 kc or 5 inches	Peak C12	4, 5, 7, 10	
16	1500 kc	Inductively coupled	STD	For max. output	Peak C16	4, 5, 7	
17	Repeat steps 15 and 16 until no further improvement in sensitivity.						
18	1500 kc	Inductively coupled	STD	Do not change from Step 16	Peak C6	4, 5, 7	

MANUAL OF 1949 MOST-OFTEN-NEEDED RADIO DIAGRAMS

General-Electric Models 376, 377, 378, Alignment continued

AM I-F VISUAL ALIGNMENT

1	455 kc ±20 kc at 60-cycle sweep	Conv. grid directly pin 7 V2 (6BE6) thru .01 mf	AM	C47 and C46*	4, 5	*Adjust for max. amplitude and min. distortion of curve on scope screen.
2	Same as Step 1	Same as Step 1	AM	C33	4, 5	Same as Step 1.
3	Same as Step 1 and 2	Same as Step 1 and 2	AM	C23 and C22	4, 5	Same as Steps 1 and 2.

FM I-F VISUAL ALIGNMENT

4	10.7 mc ±.3 mc at 60- cycle sweep	Conv. grid directly pin 7 V2 (6BE6) thru .01 mf	FM	C45 and C44	1, 2, 11	Adjust for max. amplitude and min. distortion.
5	Same as Step 4	Same as Step 4	FM	C31 and C30	1, 2, 11	Same as Step 4.
6	Same as Steps 4 and 5	Same as Steps 4 and 5	FM	C21 and C20	1, 2, 11	Same as Steps 4 and 5.

DISCRIMINATOR VISUAL ALIGNMENT

7	10.7 mc ±.3 mc at 60- cycle rate	Conv. grid directly pin 7 V2 (6BE6) thru .01 mf	FM	Primary of T5 discrim. trans- former	1, 3, 11	Adjust primary for max. amplitude.
8	Same as Step 7	Same as Step 7	FM	Secondary of T5	1, 3, 11	Adjust secondary for vertical symmetry with respect to mid- point horizontal traces.
9	Same as Step 7	Same as Step 7	FM	Primary of T5	1, 3, 11	Adjust for straightest possible slope of straight line trace.

FM R-F VISUAL ALIGNMENT

10	98 mc Note 6	Dipole terminals thru dummy antenna	FM	98 mc or 3 $\frac{1}{16}$ in.	Adjust C62*	2, 6, 7, 8, 10	*Set dial pointer accurately, then adjust for steepest slope of straight line trace on scope.
11	98 mc Note 1	Dipole terminals thru dummy antenna	FM	98 mc	Peak L4 vane	1, 2, 9, 10	Center response curve on scope, then peak for max. amplitude.
12	98 mc Note 1	Dipole terminals thru dummy antenna	FM	98 mc	Peak L1 tuning vane	1, 2, 10	Peak for max. amplitude.

AM R-F VISUAL ALIGNMENT

13	1500 kc Note 6	Antenna thru 200 mmf	STD	1500 kc or 5 in.	Adjust C12	4, 6, 7	Adjust C12 for steepest slope of straight line trace on scope.
14	1500 kc Note 5	Antenna thru 200 mmf	STD	1500 kc	Adjust C16	4, 5, 7, 9	Adjust C16 for max. ampli- tude.
15	1500 kc Note 5	Antenna thru 200 mmf	STD	1500 kc	Adjust C6	4, 5, 7	Adjust C6 for max. ampli- tude.

NOTES IN CONNECTION WITH VISUAL ALIGNMENT TABLE:

- (1) Use FM signal modulated at 60 cps ±300 kc.
- (2) Connect vertical plates of scope to the limiter grid (pin 1 of V5) (6AU6) through 200,000 ohm resistor.
- (3) Connect vertical plates of scope to the junction of R29 and R41 (FM audio) through 200,000 ohms.
- (4) Connect vertical plates of scope at junction of R13 and C28 (AM audio output) through 200,000 ohms.
- (5) Use FM signal modulated at 60 cps ±20 kc.
- (6) Use a 60 cycle amplitude modulated signal.
- (7) If a dial scale is not available, index the dial pointer as follows: Turn the pointer to the left-hand limit of travel and mark the dial plate at a reference edge of the pointer slide. Then set the pointer by turning dial knob until the indicated dimension exists between the reference edge and the mark.

(8) Two oscillator settings will give a response. The higher frequency response is the correct one, the other response is the image. If in doubt, start with the trimmer screw loosened completely and adjust for the *first* response.

(9) In some cases tuning of the converter grid will cause "pulling" of oscillator which will change the oscillator frequency. After centering the response curve on the scope, if peaking of L4 causes the response curve to move off of the screen it is necessary to realign the oscillator for calibration.

(10) A dummy antenna is a resistor in series with the hot lead of the signal generator. The resistance of the resistor plus the termination impedance of the signal generator should equal 300 ohms.

(11) Leads from the signal generator must be kept as short as possible and away from later stages to prevent regeneration. The signal may also be fed to the tube pin connection from the top of the chassis to prevent regeneration.

MANUAL OF 1949 MOST-OFTEN-NEEDED RADIO DIAGRAMS

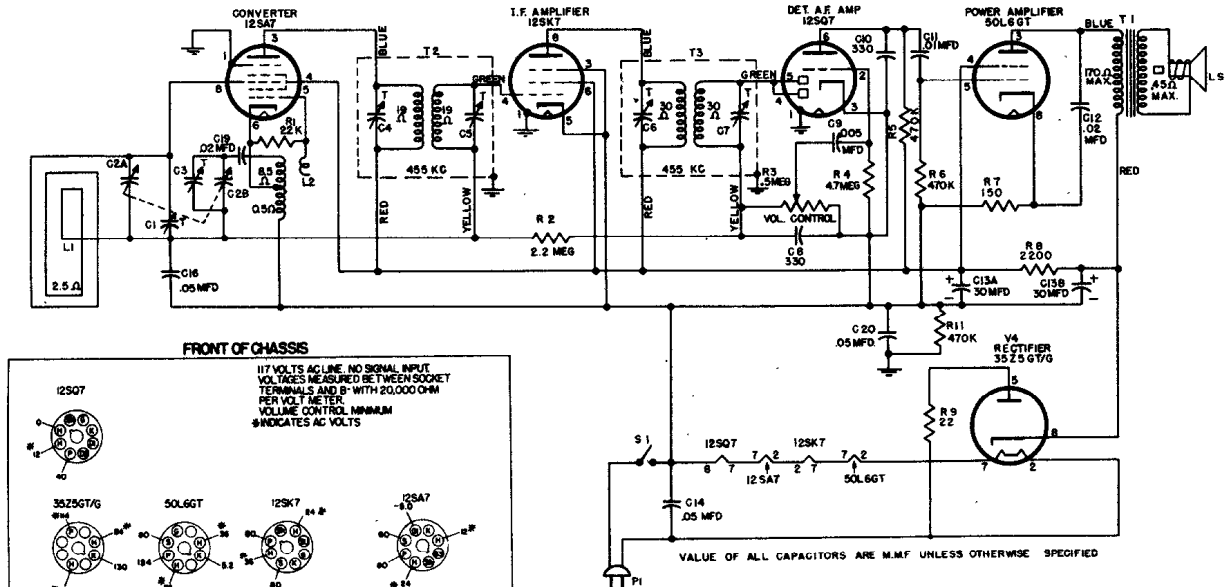

I-F ALIGNMENT

Connect an output meter across the voice coil. Turn the volume control to maximum. Set test oscillator to 455 KC and keep the oscillator output as low as a readable meter reading will permit. Apply signal to the converter grid through a .05 mfd. capacitor and align progressively the trimmers in the 2nd and 1st I-F transformer cans.

R-F ALIGNMENT

Apply the R-F alignment signals through a standard IRE dummy antenna to the primary on the loop. With the gang condenser wide open, align the oscillator trimmer (C3) to 1720 KC. Change the generator signal to 1500 KC, tune the receiver to the signal and peak the antenna trimmer (C1) for maximum output.

GENERAL ELECTRIC

MODELS 102, 102W, 107, 107W, 114, 114W, 115, 115W

GENERAL ELECTRIC

RECORD PLAYER

MODEL 14

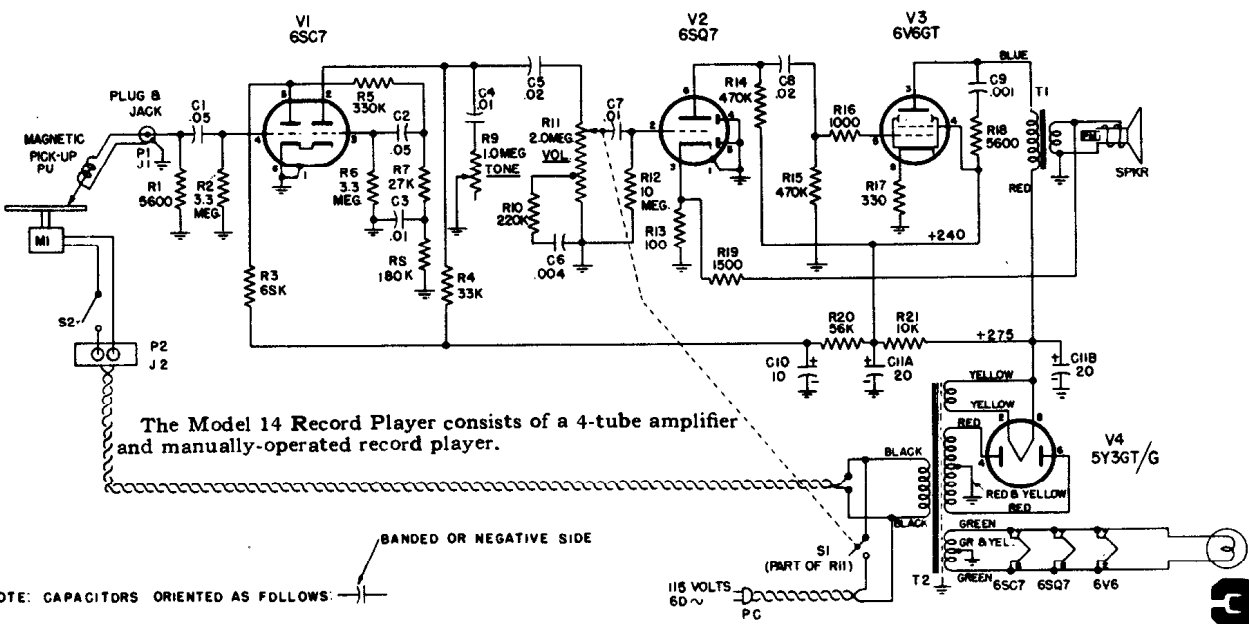

The Model 14 Record Player consists of a 4-tube amplifier and manually-operated record player.

NOTE: CAPACITORS ORIENTED AS FOLLOWS:

MANUAL OF 1949 MOST-OFTEN-NEEDED RADIO DIAGRAMS

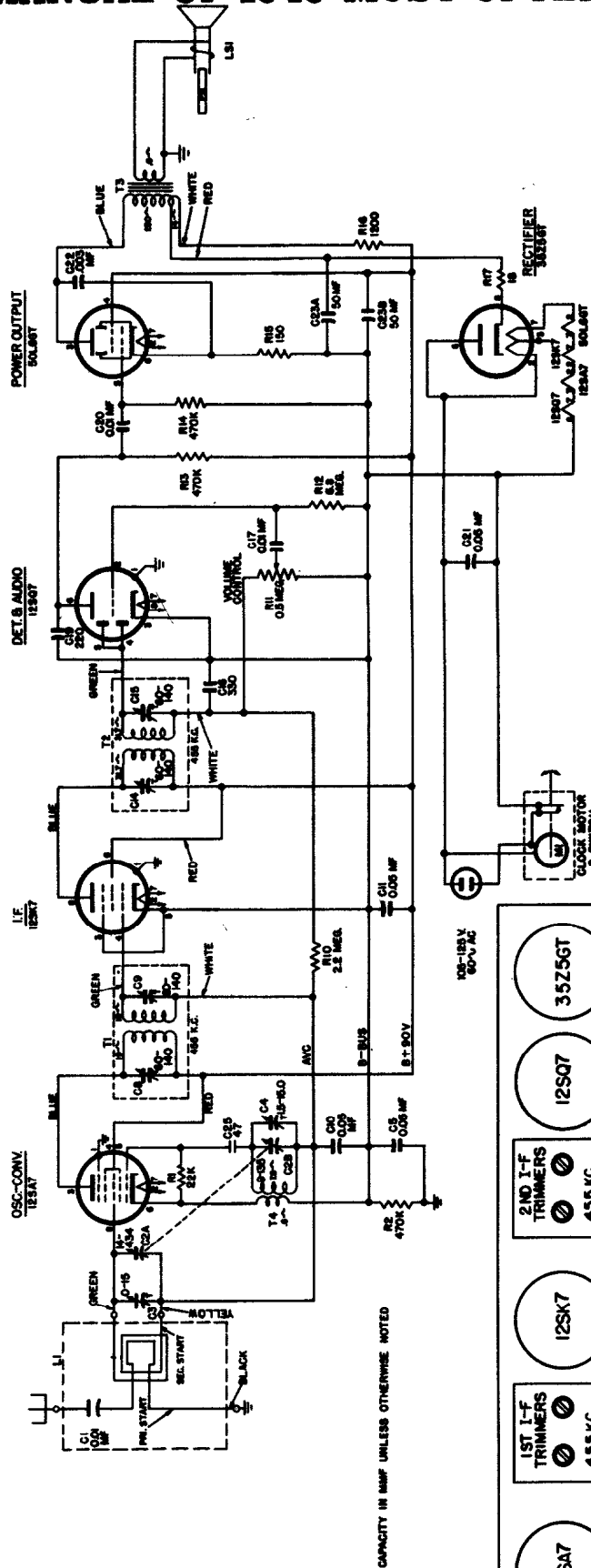

GENERAL ELECTRIC

SERVICE DATA

FOR

CLOCK-RADIO

MODELS 60 AND 62

ALIGNMENT CHART

Step	Connect Test Oscillator to—	Test Osc. Setting	Dial Drum Setting	Adjust Trimmers for Maximum Output
1	12SK7 grid (4) in series with 0.05 mf. cap.	455 kc	1600 kc	2nd i-f trans. trimmers, C14 and C15
2	12SA7 grid (8) in series with 0.05 mf. cap.	455 kc	1600 kc	1st i-f trans. trimmers, C8 and C9
3	Antenna Post in series with 200 mmf. cap.	1500 kc	1500 kc	C4 (oscillator)
4	Antenna Post in series with 200 mmf. cap.	1500 kc	1500 kc	C3 (antenna)

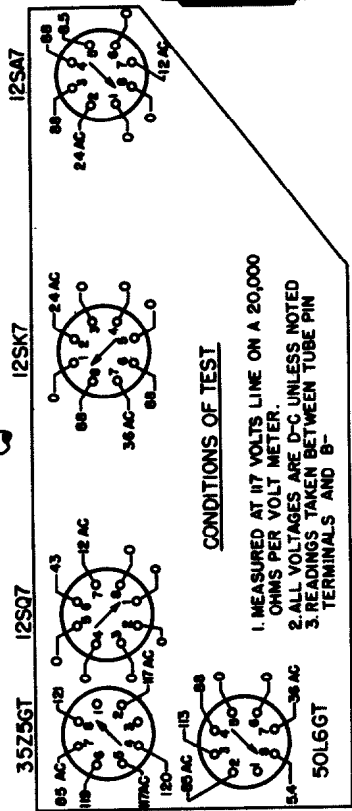
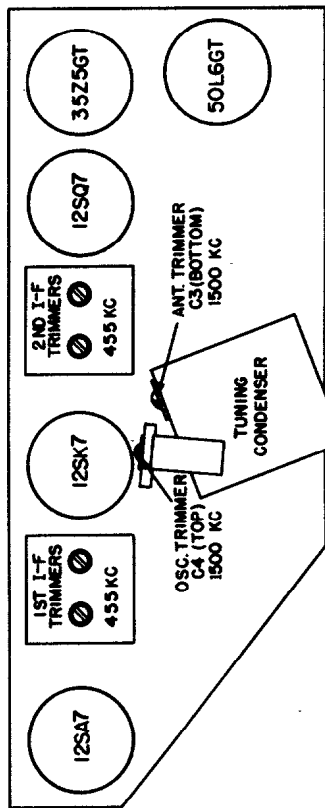
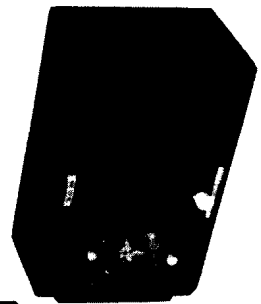

CONDITIONS OF TEST

1. MEASURED AT 117 VOLTS LINE ON A 20,000 OHMS PER VOLT METER.
2. ALL VOLTAGES ARE D-C UNLESS NOTED
3. READINGS TAKEN BETWEEN TUBE PIN TERMINALS AND B-

VIEWED FROM BOTTOM OF CHASSIS

MANUAL OF 1949 MOST-OFTEN-NEEDED RADIO DIAGRAMS

GENERAL ELECTRIC RADIO SERVICE DATA FOR MODELS 118, 119W and 119M

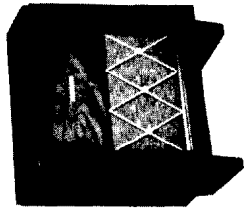

119M and 119W

ALIGNMENT CHART

Step	Connect Test-Oscillator To:	Test Oscillator Setting	Dial Setting	Adjust Trimmers For Max. Output
1	12SK7 grid (Pin 4) in series with .05 mf.	455 kc	—	C6 and C7
2	12BE6 grid (Pin 7) in series with .05 mf.	455 kc	—	C4 and C5 Readjust C6 and C7
3	Blue wire on loop in series with 200 mmf. and 470 ohms.	1500 kc	1500 kc	C12 (Osc.); C2 (Ant.)*

* Rock gang condenser when making alignment.

The oscillator trimmer is accessible by tilting the chassis slightly in the cabinet. The antenna trimmer is on the loop and is accessible from the rear of the cabinet. The locations of these trimmers are shown in Figure 3.

The output meter should be connected across the loudspeaker coil terminals. The low side of the test oscillator should be connected to B minus; the high side should be connected as indicated in the Alignment Chart.

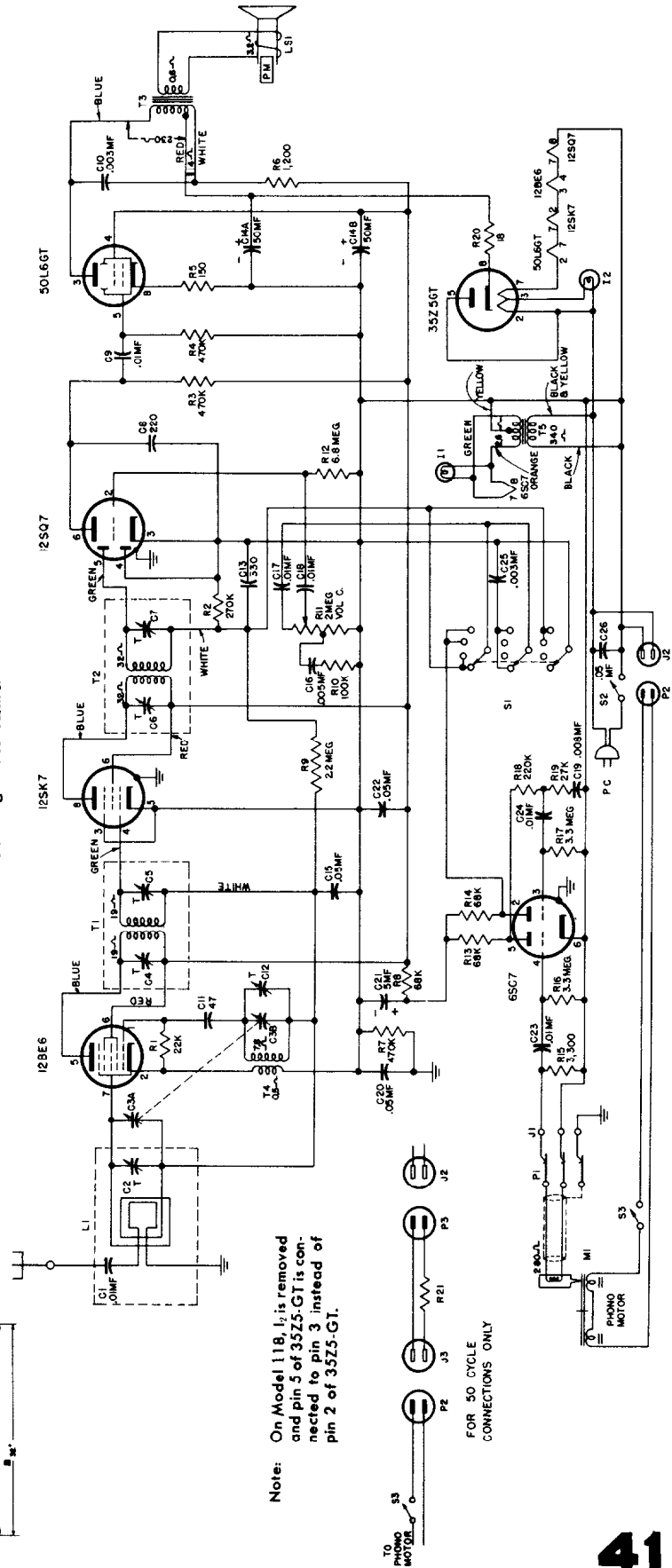
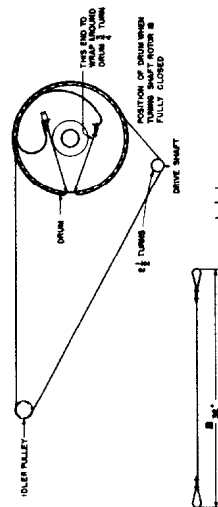
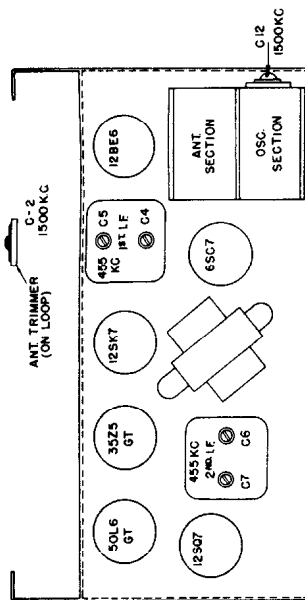

Note: On Model 118, I1 is removed and pin 5 of 3525-GT is connected to pin 3 instead of pin 2 of 3525-GT.

FOR 50 CYCLE CONNECTIONS ONLY

MANUAL OF 1949 MOST-OFTEN-NEEDED RADIO DIAGRAMS

GENERAL ELECTRIC

RADIO

SERVICE DATA

FOR

MODEL 113

ALIGNMENT PROCEDURE

ALIGNMENT FREQUENCIES:

I-F 455 kc
 R-F 1725 kc and 1500 kc
 The location of all trimmers is shown in Figure 1.

I-F ALIGNMENT:

Connect an output meter across the voice coil. Turn the volume control to maximum. Set test oscillator to 455 kc and keep the oscillator output as low as a readable meter reading will permit. Apply signal to the converter grid through a .05 mfd. capacitor and align progressively the trimmers in the 2nd and 1st i-f transformer cans.

R-F ALIGNMENT:

Apply the r-f alignment signals through a standard IRE dummy antenna to C9. With the gang condenser wide open, align the oscillator trimmer (C11) to 1725 kc. Change the generator signal to 1500 kc, tune the receiver to the signal, and peak antenna trimmer (C9) for maximum output.

PRECAUTION:

If the signal generator is a-c operated, use an isolating transformer between the power supply and the radio receiver power input. The use of an isolating capacitor is not recommended, as a-c through the capacitor will introduce hum modulation and/or create the possibility of a burned-out signal generator attenuator.

CABINET:

OVER-ALL DIMENSIONS:

Height 6 in.
 Width 9 1/4 in.
 Depth 4 3/4 in.

ELECTRICAL RATING:

Voltage 105-125 v. AC or DC
 Frequency on AC 40-60 cps
 Wattage (at 117 volts) 28 watts

OPERATING FREQUENCIES:

Broadcast Band 540-1725 kc
 Intermediate Frequency 455 kc

LOUDSPEAKER "ALNICO V" MAGNET DYNAMIC

Outside Cone Diameter 4 in.
 Voice Coil Impedance (400 cycles) 3.5 ohms

TUBES COMPLEMENT:

Converter-Oscillator 12SA7
 I-F Amplifier 12SK7
 Detector, AVC Audio 12SQ7
 Power Output 50L6GT
 Rectifier 35W4

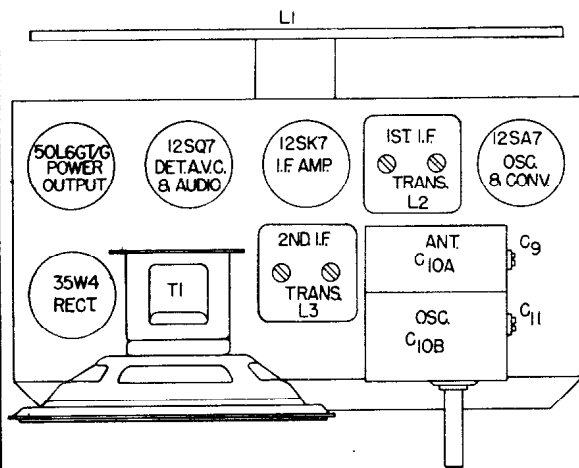

Tube and Trimmer Location

FRONT OF CHASSIS

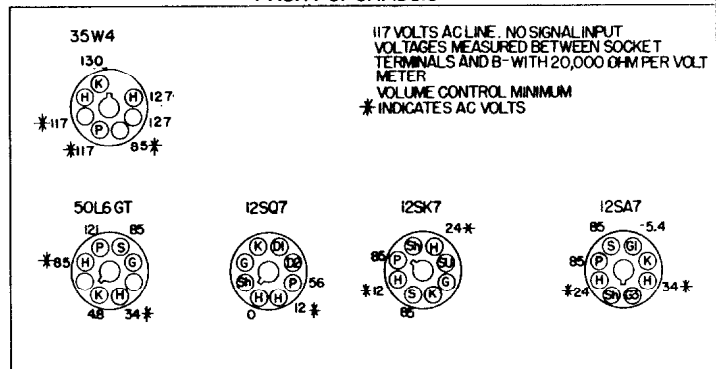

BOTTOM VIEW OF CHASSIS

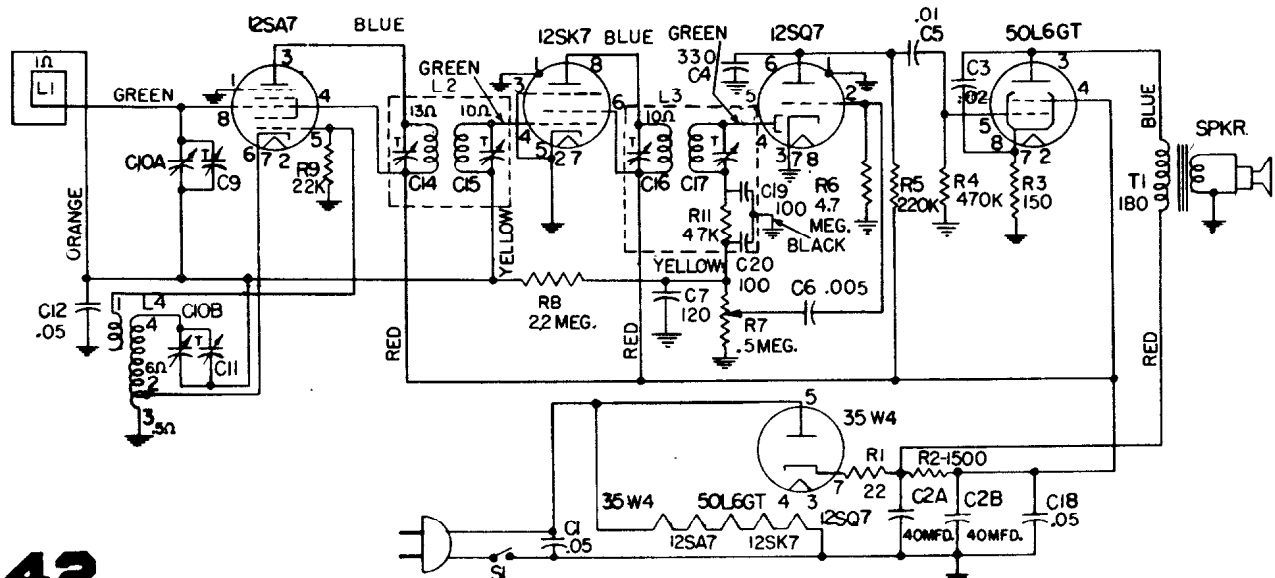

MANUAL OF 1949 MOST-OFTEN-NEEDED RADIO DIAGRAMS

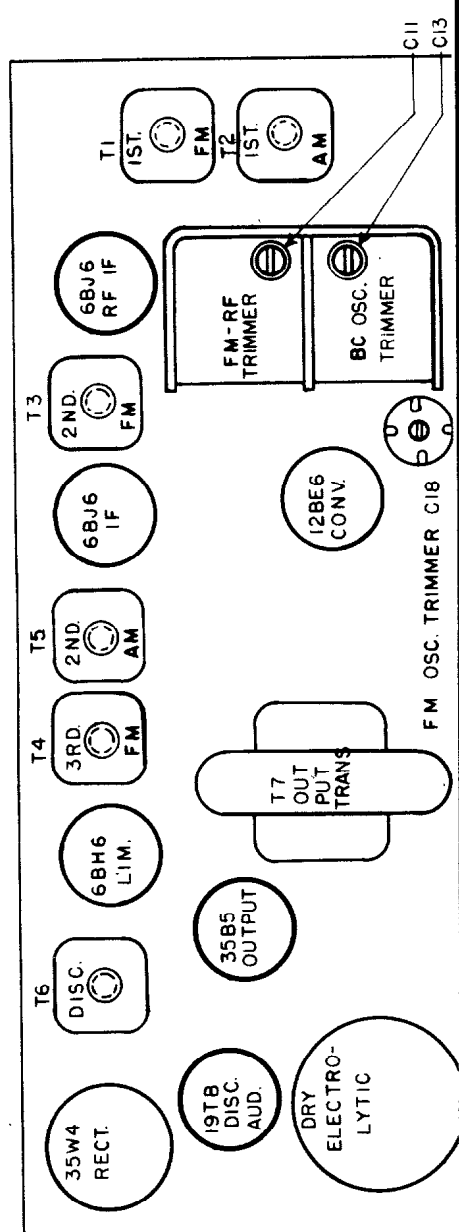
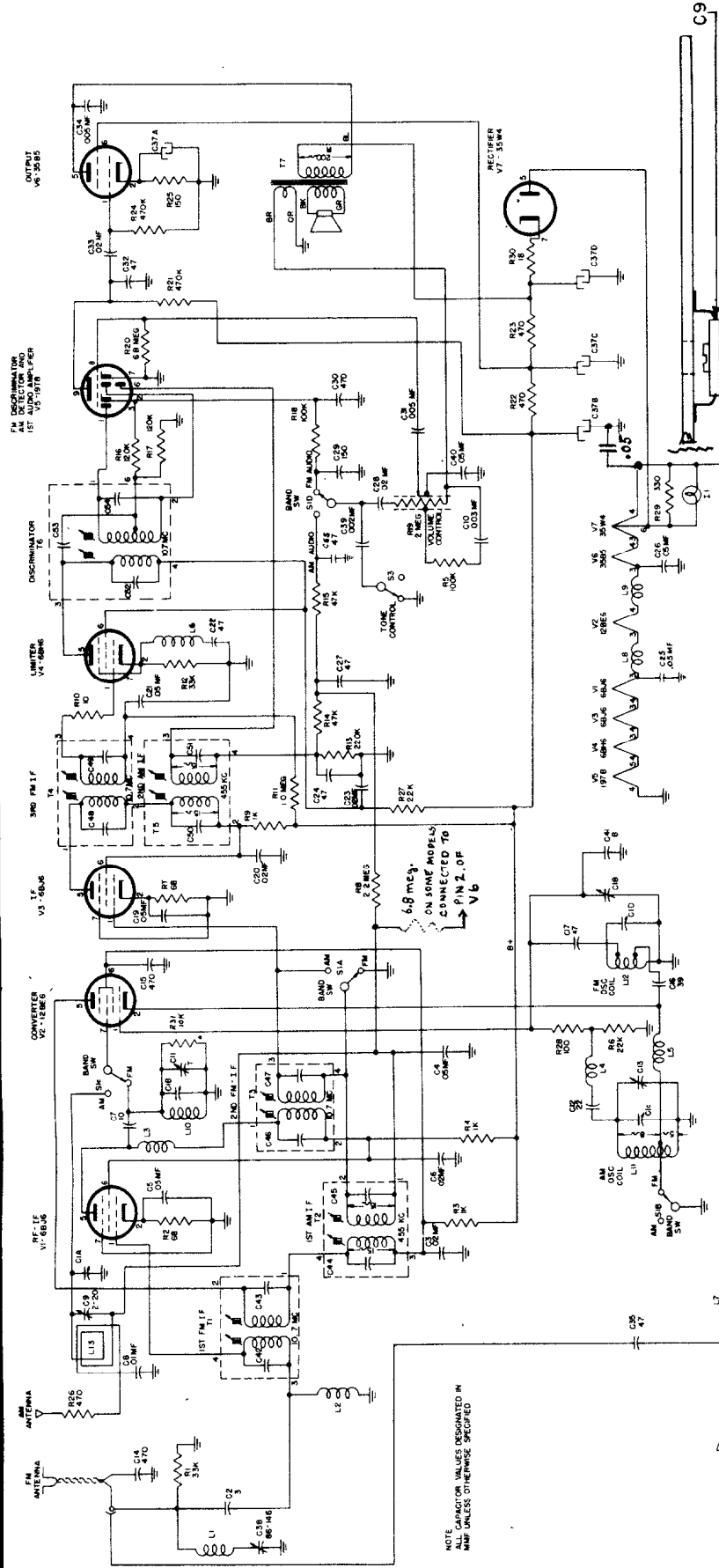

TUNING BAND:
 AM540-1600 kc
 FM88-108 mtc

INTERMEDIATE FREQUENCIES:
 AM455 kc
 FM10.7 mtc

GENERAL ELECTRIC
 RADIO SERVICE DATA FOR
MODELS 210, 211, 212



MANUAL OF 1949 MOST-OFTEN-NEEDED RADIO DIAGRAMS

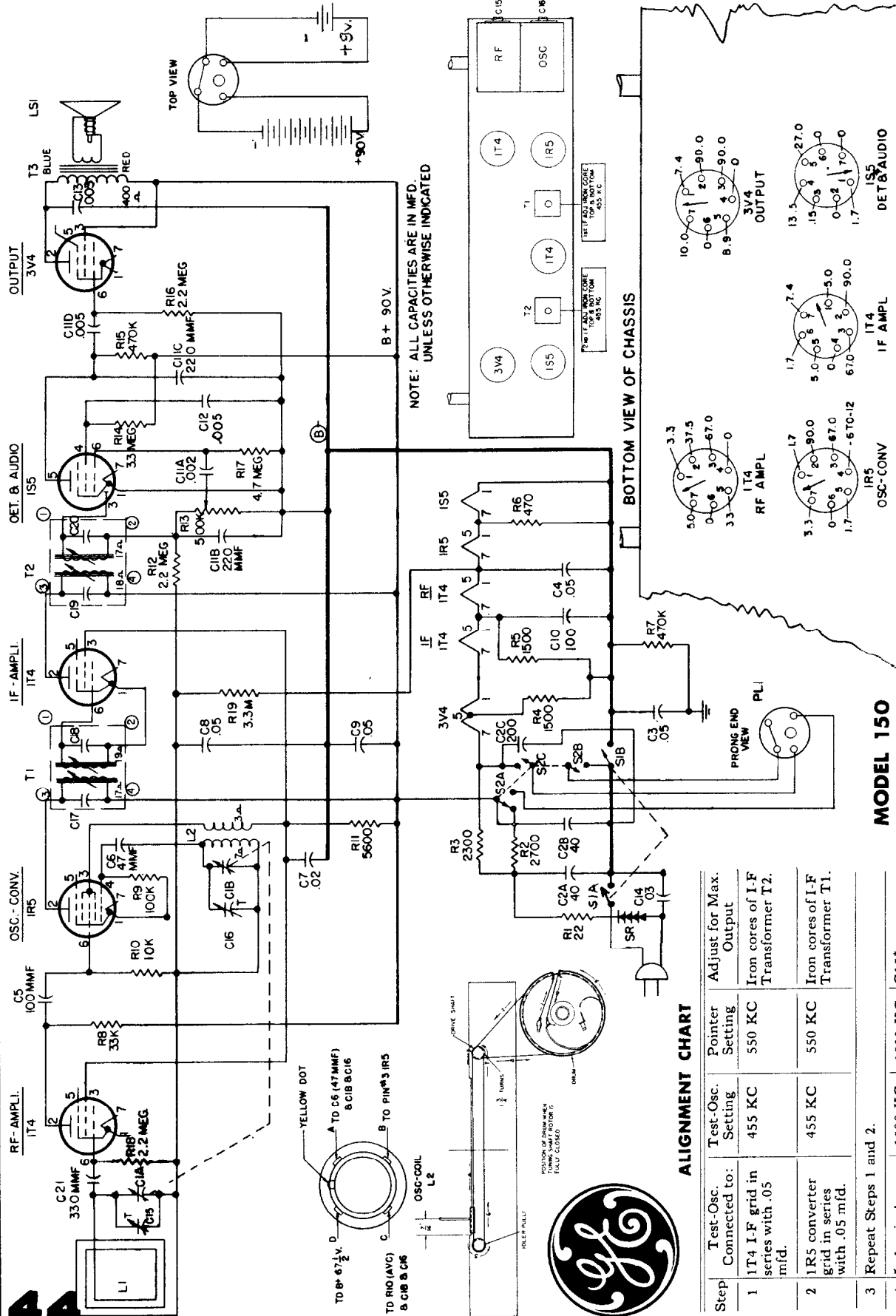

DC VOLTAGES TO GROUND UNLESS OTHERWISE SPECIFIED
 ALL RATINGS ARE AC OPERATION MEASURED WITH REFERENCE TO B-
 VOLTAGE IS MEASURED WITH 20000 OHMS PER VOLT METER

ALIGNMENT CHART

Step	Test-Osc. Connected to:	Test-Osc. Setting	Pointer Setting	Adjust for Max. Output
1	1T4 I-F grid in series with .05 mfd.	455 KC	550 KC	Iron cores of I-F Transformer T2.
2	1R5 converter grid in series with .05 mfd.	455 KC	550 KC	Iron cores of I-F Transformer T1.
3	Repeat Steps 1 and 2.			
4	Inductively coupled	1500 KC	1500 KC	C15*
				C16

* Chassis in cabinet and cabinet back (with loop) closed; remove plug button to adjust C15.



OF 1949 MOST-OFTEN-NEEDED RADIO DIAGRAMS

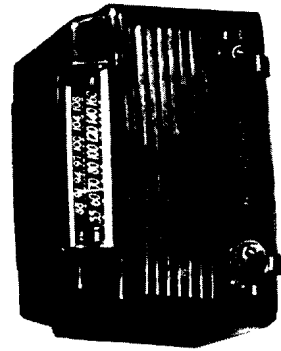
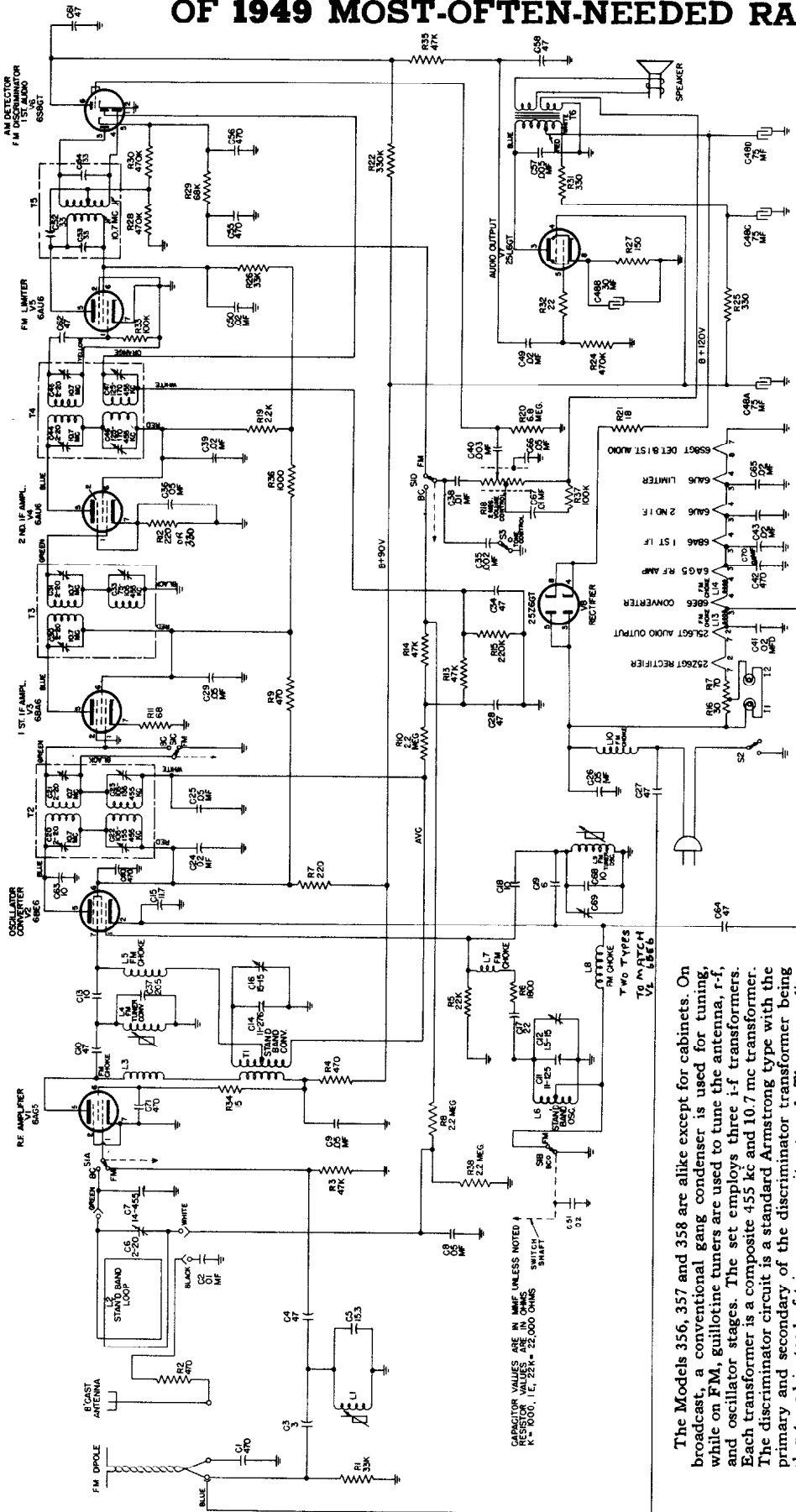

Model 356—Mahogany Plastic
Model 357—Ivory Plastic

GENERAL ELECTRIC

RADIO

SERVICE DATA

FOR

MODELS 356, 357 AND 358

The Models 356, 357 and 358 are alike except for cabinets. On broadcast, a conventional gang condenser is used for tuning, while on FM, gullotine tuners are used to tune the antenna, r-f, and oscillator stages. The set employs three i-f transformers. Each transformer is a composite 455 kc and 10.7 mc transformer. The discriminator circuit is a standard Armstrong type with the primary and secondary of the discriminator transformer being slug tuned instead of trimmer capacitor tuned. The power line antenna is used when there is no external dipole and is utilized by attaching the blue wire on the cabinet back to the top dipole terminal. This should be disconnected when a dipole is used. For best reception with a power line antenna, the power cord should not be coiled up.

TUNING BAND:

Standard Broadcast.....540-1600 kc
FM.....88-108 mc

INTERMEDIATE FREQUENCY:

Standard Broadcast.....455 kc
FM.....10.7 mc

MANUAL OF 1949 MOST-OFTEN-NEEDED RADIO DIAGRAMS

THE B. F. GOODRICH CO.

Mantola

Models **92505**
92506

VOLTAGE DATA

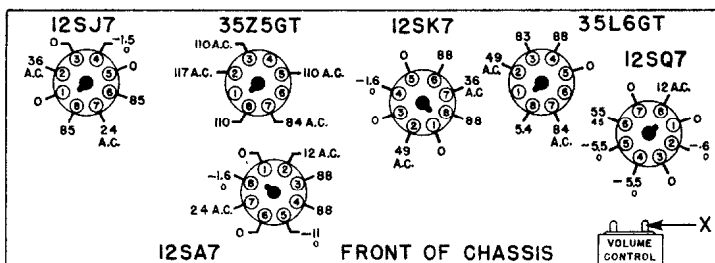

Bottom View of Chassis, Showing Voltages

- Readings made between point indicated and Volume Control Lug (Point "X" on drawing).
- Measured on a 117 Volt A.C. line.
- Dial turned to low frequency end, no signal.
- Measured with Vacuum Tube voltmeter.
- A second voltage reading is shown made with a 1000 ohm-per-volt meter when use of this instrument would result in appreciably lower readings.

REPLACEMENT PARTS

RESISTORS		COILS & TRANSFORMERS	
Symbol	Part No.	Description	Part No.
R1.. 10,000 Ohms, 1/2 Watt	60B 8-103	L1.. Loop Antenna	69C 44
R2.. 10 Megohms, 1/2 Watt	60B 8-106	L2.. R.F. Coil and Mounting	A1052
R3.. 22,000 Ohms, 1/2 Watt	60B 8-223	L3.. Oscillator Coil	69A 43
R4.. 100 Ohms, 1/2 Watt	60B 8-101	T1.. Transformer, Output	98A 4
R5.. 1 Megohm, 1/2 Watt	60B 8-105	T2.. Transformer, 1st I.F.	72B 50
R6.. 1/2 Megohm, Volume Control & Switch	75B 1-6	T3.. Transformer, 2nd I.F.	72B 51
R7.. 4.7 Megohms, 1/2 Watt	60B 8-475		
R8.. 270,000 Ohms, 1/2 Watt	60B 8-274		
R9.. 470,000 Ohms, 1/2 Watt	60B 8-474		
R10.. 150 Ohms, 1/2 Watt	60B 28-151		
R11.. 33 Ohms, 1 Watt	60B 28-3		
R12.. 1,000 Ohms, 1 Watt	60B 28-2		
R13.. 150,000 Ohms, 1/2 Watt	60B 8-154		

CONDENSERS		MISCELLANEOUS	
Symbol	Part No.	Description	Part No.
C1.. 785 mmfd., ±5%, Silver Mica	65B 1-8	Background, Dial	X22C3-1
C2.. 250 mmfd., Mica	65B 7-22	Bracket Plate, Loop Retainer	15A 14
C3.. .02 mfd., 400 Volts, Paper	64B 1-24		
C4.. 50 mmfd., Mica	65B 7-11		
C5a. 0 to 420 mmfd.	Gang 68A 18		
C5b. 0 to 108 mmfd.			

MISCELLANEOUS	
Description	Part No.
Buttons, Snap (for R.F. Coil)	13A 1-2-2
Cabinet, Ivory (Model 92505)	34D 8-1
Cabinet, Mahogany (Model 92506)	34D 8-2
Clip, Dial Glass	18A 2
Cord, Dial	50A 1-3
Cover, Back (Incl. Loop Antenna)	69C 44
Dial Scale, Glass	21B 10-2
Drum and Cam Assembly	A1049
Knob, Mahogany (Model 92506)	33A 7-2
Knob, Ivory (Model 92505)	33A 7-1
Lever Arm Assembly (R.F.)	A1050
Pilot Light, No. 47	81A 1-8
Pilot Light Socket and Leads	82A 2-3
Pointer	25A 13-1
Pulley, Fibre; 1/2x1/2" OD	17A 1-3
Screw, Set; 8/32x1/8" (Dial Drum)	1A 5-58
Shaft, Tuning	28A 1-1
Slug, R.F. Iron Core (with wire)	71B 1-2
Socket, Octal Tube	87A 10-2
Speaker (5" PM) and Transformer	78B 4-4
Spring, Tension (Dial)	19B 1-3
Spring, Lever Arm (R.F.)	19A 4
Spacer, T (R.F.)	29A 2-3-21
Stud, Slug Adj. (R.F.)	27A 4
Washer, C (Tuning Shaft)	4A 4-6
Washer, Spring (Tuning Shaft)	4A 6-3-0

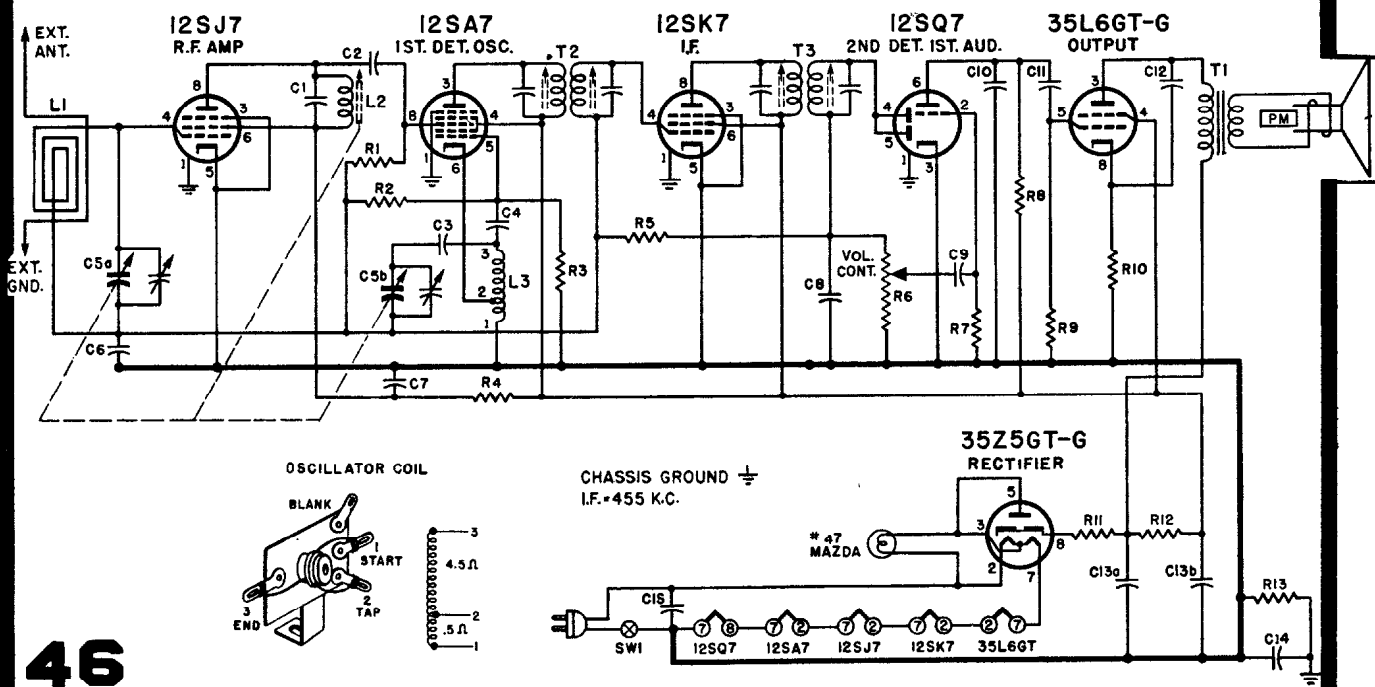

MANUAL OF 1949 MOST-OFTEN-NEEDED RADIO DIAGRAMS

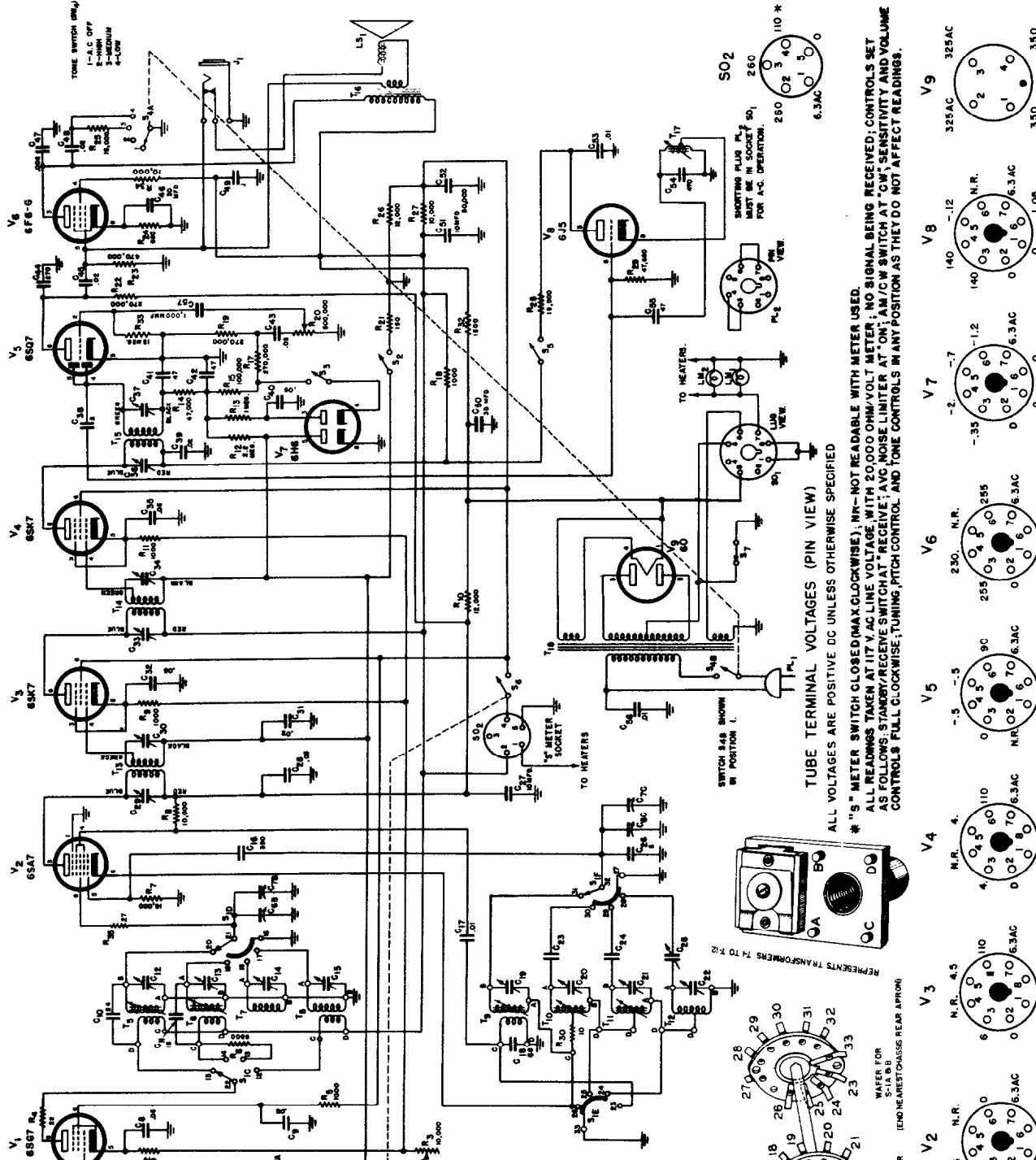

NOTE
RESISTANCE VALUES ARE IN OHMS UNLESS OTHERWISE SPECIFIED.
CAPACITOR VALUES ARE IN MICROFARADS UNLESS OTHERWISE SPECIFIED.
CAPACITOR VALUES IN P.F. DENOTE PAPER CAPACITOR VALUES.

Z DENOTES MECHANICAL GAINING

PHI VALUES AT BANDSWITCH (S1) AND LETTERS AT ANTENNA, MIXER AND OSCILLATOR TRANSFORMERS (T1 TO T2) IDENTIFY CORRESPONDING TERMINAL LINES ON PICTORIAL VIEWS

**The Hallicrafters
MODEL S-40 A**

REPRESENTS TRANSFORMERS T1 TO T12

SHOWN IN POSITION FOR BAND NO. 1 OPERATION.

BAND SWITCH S-1

WAFER FOR S-1E & S WAFER FOR S-1A & B

WAFER FOR S-1C & D (END NEAREST CHASSIS REAR APRON)

TO HEATERS.

SWITCH S-2 SHOWN IN POSITION 1.

TUBE TERMINAL VOLTAGES (PIN VIEW)
ALL VOLTAGES ARE POSITIVE DC UNLESS OTHERWISE SPECIFIED

*** "S" METER SWITCH CLOSED (MAX. CLOCKWISE), "NR" - NOT READABLE WITH METER USED.
ALL READINGS TAKEN AT 117 V AC LINE VOLTAGE WITH 20,000 OHM VOLT METER; NO SIGNAL BEING RECEIVED; CONTROLS SET AS FOLLOWS: STANDBY/RECEIVE SWITCH "RECEIVE"; A/C NOISE LIMITER AT "ON"; AM/CW SWITCH AT "CW"; SENSITIVITY AND VOLUME CONTROLS FULL CLOCKWISE; TUNING, PITCH CONTROL AND TONE CONTROL AS THEY DO NOT AFFECT READINGS.**

V1 N.R. 1.5 0 100 0 260 0
0 0 1 7.0 6.3AC 0
0 2 1 6.0 0
0 3 0 0 0

V2 N.R. 95 0 0 0
0 0 1 7.0 6.3AC 0
0 2 1 6.0 0

V3 N.R. 4.5 0 110 0 260
0 0 2 10 0 6.3AC 0
0 3 0 0 0

V4 N.R. 4. 0 110 0 245
0 0 3 0 10 0 6.3AC 0
0 2 1 6.0 0

V5 -5 -5 0 0 0 0
0 0 3 0 60 90 0
0 2 1 6.0 0 6.3AC 0

V6 N.R. 230. 0 255 0 17
0 0 3 0 60 255 0
0 2 1 6.0 0 6.3AC 0

V7 -2 -7 0 0 0
0 0 3 0 5 60 0 1.2
0 2 1 6.0 0 6.3AC 0

V8 140 -12 140 0 1.06
0 0 3 0 5 60 0 N.R.
0 2 1 6.0 0 6.3AC 0

V9 325AC 0 350
0 0 3 0 0 0 0
0 2 1 0 0 0 0 350

502 260 0 350 0 110
0 2 3 4 0 0 0 6.3AC
0 1 5 0 0 0

MANUAL OF 1949 MOST-OFTEN-NEEDED RADIO DIAGRAMS

The Hallicrafters Co.

MODEL S-40 A

ALIGNMENT

EQUIPMENT:

1. Signal Generator capable of the ranges indicated in the Alignment Chart, including a 400 cycle audio modulator.
2. Output meter capable of handling 1.5 watts of audio power.
3. Standard RMA dummy consisting of a 200 mmf condenser in series with a 20uh r-f choke which is shunted by a 400 mmf condenser in series with a 400 ohm carbon resistor.
4. Non-metallic screw driver.

CONNECTIONS: Connect the Sig. Gen. "cold" lead to the receiver's chassis; the "hot" lead is connected as indicated in the Chart.

Connect the output meter across the speaker voice coil. Caution: Set the meter at a sufficiently high range to prevent possible damage from overload.

CONTROL SETTINGS: After allowing about a ten minute warm up period, set the receiver's control as follows:

SENSITIVITY control at full clockwise (maximum).

VOLUME control at full clockwise (maximum).

CW/AM switch at "AM" (except for BFO adjustment).

A.V.C. switch at "OFF."

NOISE LIMITER switch at "OFF."

TONE control at "HIGH".

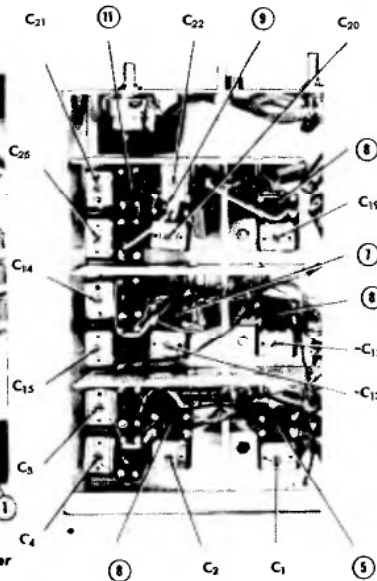

Top and bottom views of the receiver locating slugs, padders and trimmers.

DUMMY ANT. IN SERIES WITH SIG. GENERATOR	CONNECTION OF SIG. GENERATOR OUTPUT TO RECEIVER	SIGNAL GEN. FREQUENCY SETTING	BAND SWITCH SETTING	RECEIVER DIAL SETTING	ADJUST SLUG, PADDER, OR TRIMMER NO.	DESCRIPTION	TYPE OF ADJUSTMENT — MAKE ADJUSTMENT FOR:	STEP NO.
IF ADJUSTMENT								
None	Stator plates of center sect. of tuning gang	455 kc	"1"	1000 kc	3 (both) 2 (both) 1 (both)	3rd IF 2nd IF 1st IF	Maximum output Maximum output Maximum output Repeat steps 1, 2 and 3	1 2 3
BFO ADJUSTMENT—NOTE: Turn off Sig. Gen. 400 cycle modulation; set CW/AM switch at "CW"; remove Pitch Control knob adjust slotted screw shaft.								
None	Stator plates of center sect. of tuning gang	455 kc	"1"	1000 kc	T-17 slug (See Fig. 3 for location)	BFO slug	Zero heat	4
BAND #4 ADJUSTMENT—NOTE: Make sure 400 cycle audio modulator is turned on; AM/CW switch should be at "AM."								
STANDARD	"A1" on antenna	36 mc	"4"	36 mc	C-19	Osc. Trimmer	Maximum output	5
RMA Dummy strip		18 mc		18 mc	8	Osc. Slug	Maximum output and repeat step 5	6
		36 mc		36 mc	†C-1	RF Trimmer	Maximum output	7
		36 mc		36 mc	†C-12	Mix. Trimmer	Maximum output	8
		18 mc		18 mc	*†5	RF Slug	Maximum output and repeat step 7	9
		18 mc		18 mc	*†6	Mix Slug	Maximum output and repeat step 8	10
BAND #3 ADJUSTMENT								
STANDARD	"A1" on antenna	14 mc	"3"	14 mc	C-20	Osc. Trimmer	Maximum output	11
RMA Dummy strip		10 mc		10 mc	* 9	Osc. Slug	Maximum output and repeat step 11	12
		14 mc		14 mc	†C-2	RF Trimmer	Maximum output	13
		14 mc		14 mc	†C-13	Mix. Trimmer	Maximum output	14
		7 mc		7 mc	*† 4	RF Slug	Maximum output and repeat step 13	15
		7 mc		7 mc	*† 7	Mix. Slug	Maximum output and repeat step 14	16
BAND #2 ADJUSTMENT								
STANDARD	"A1" on antenna	5 mc	"2"	5 mc	C-21	Osc. Trimmer	Maximum output	17
RMA Dummy strip		3 mc		3 mc	* 11	Osc. Slug	Maximum output and repeat step 17	18
		5 mc		5 mc	C-3	RF Trimmer	Maximum output	19
		5 mc		5 mc	C-14	Mix. Trimmer	Maximum output	20
BAND #1 ADJUSTMENT								
STANDARD	"A1" on antenna	1500 kc	"1"	1500 kc	C-22	Osc. Trimmer	Maximum output	21
RMA Dummy strip		600 kc		600 kc	C-25	Osc. Padder	Maximum output and repeat step 21	22
		1500 kc		1500 kc	C-4	RF Trimmer	Maximum output	23
		1500 kc		1500 kc	C-15	Mix. Trimmer	Maximum output	24

48

*It may be necessary to repeat the indicated adjustments several times.

†Rock the main tuning capacitor slightly (turn back and forth) when making these adjustments.

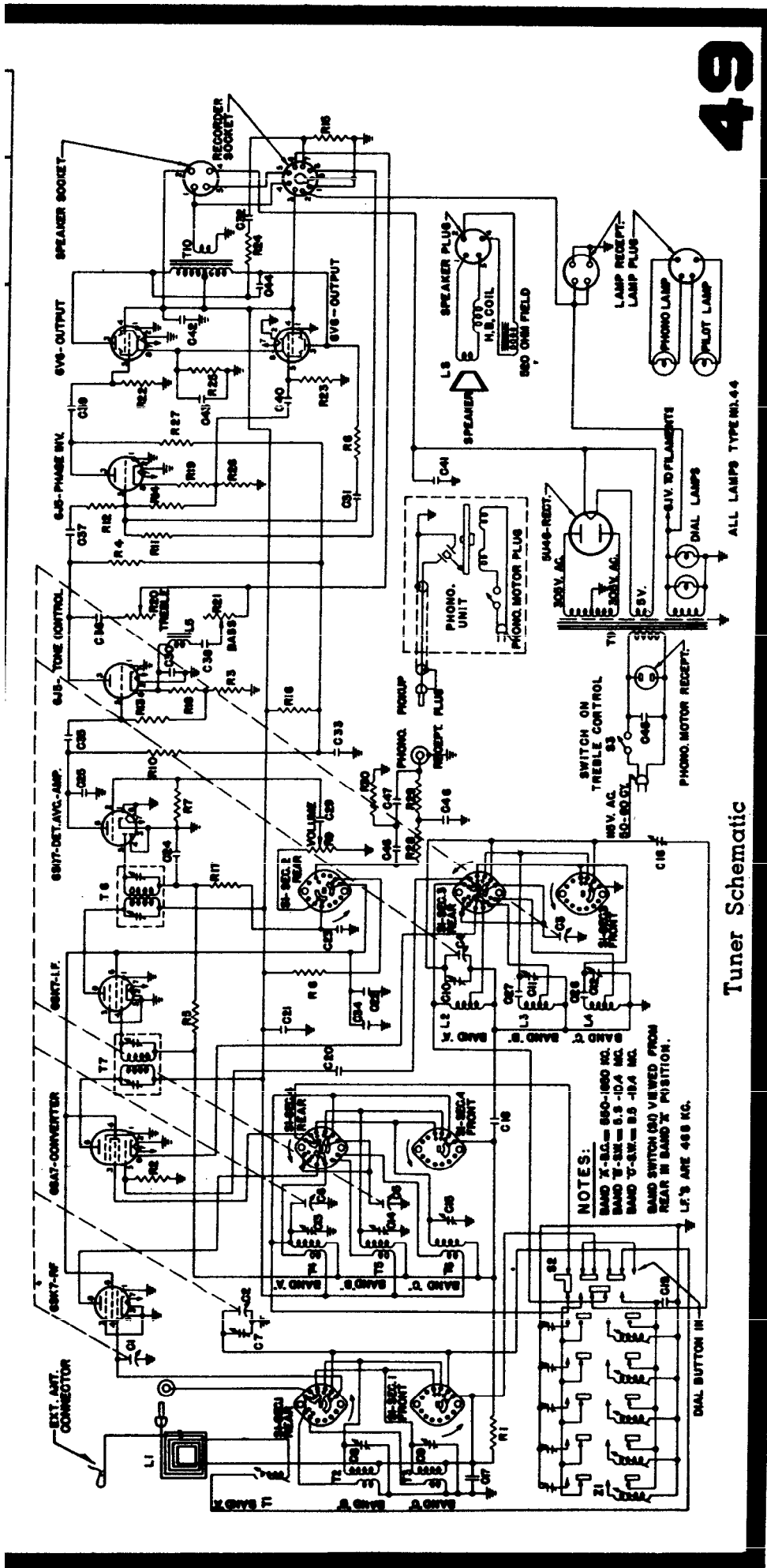

Tuner Schematic

ALL LAMPS TYPE 6X4

MANUAL OF 1949 MOST-OFTEN-NEEDED RADIO DIAGRAMS

Hoffman RADIO CORP.

Models B503, B513, Chassis 115

TUNING RANGES:

Band "A"	540 Kc to 1600-Kc.
Band "B"	56 MC to 10.4 Mc.
Band "C"	9.4 Mc to 19.4 Mc
Intermediate Frequency	455 Kc
Power Supply	115V. A.C., 50-60 C.P.S.

Hoffman Models C503 and C513 are electrically identical with Models B503 and B513 respectively, except for the following:

1. Push-pull parallel 6K6's are used in the output stage instead of push-pull 6V6's.
2. An "Entertainment Panel" has been wired into the tuner chassis to provide microphone input, a speaker off-on switch, a pillow speaker plug, and an auxiliary phono input.
3. A resistance-capacity filter has been inserted in the B-plus line feeding the phase inverter stage (see R111 and C110, power supply schematic)
4. On the recorder amplifier the screen dropping resistor (R111) has been changed from .1 meg to 2.2 meg and the cathode resistor (R2) for this stage changed from 2200 ohms to 4700 ohms.

SYMBOL	TUNER CHASSIS DESCRIPTION	HOFFMAN No.	*LIST PRICE
C1-C2, C3-C4,	Three-Section Variable with Split Stator (160-260, 160-260, 160-260 Mmf.)	4403	6.88
C5-C6	Three-Section Trimmer Assembly	4300	.76
C10, C11, C12	Three-Section Trimmer Assembly	4300	.76
C13, C14, C15	Three-Section Trimmer Assembly	4301	.75
C16	110-560 Mmf., Padder, Band "A"	4100	.45
C17, C18,	500 Mmf., - 5% Silver Mica	4007	.45
C19	47 Mmf., - 10% Mica	4101	.23
C20	.05 Mfd., 400 Volt, Tubular Paper	4005	.18
C21	100 Mmf., - 20% Mica	4000	.42
C22	1050 Mmf., - 5% Mica	4102	.63
C23	2300 Mmf., - 5% Mica	4106	.42
C24, C25	.005 Mfd., 600 Volt, Tubular Paper	4106	1.24
C26, C27	.01 Mfd., 450 Volt, Tubular Electrolytic	4112	.19
C28	.5 Mfd., 200 Volt, Tubular Paper	4110	.41
C29, C30	.02 Mfd., 400 Volt, Tubular Paper	4106	.19
C31, C32	20-20.20 Mfd., 450-450 25V. Electrolytic	4200	2.28
C33, C34, C35, C36, C37	.01 Mfd., 600 Volt, Tubular Paper	4104	.20
C38, C39, C40	.01 Mfd., 600 V. Tubular Paper, Metal Can.	4105	.37
C41, C42, C43	.02 Mmf., - 5% Mica	4010	.34
C44	.450 Mmf., - 5% Mica	4011	.38
C45	Loop Antenna (Band "A")	52210	1.85
L1	Resistor	5215	1.08
L2, L3, L4	Oscillator Coil (Bands "B" and "C")	5218	1.68
L5	Choke B. Resistor	5103	3.80
R1	12" Loudspeaker (Electrodynamic)	4044	.05
R2	1 Megohm - 20% 1/2 Watt	4511	.05
R3	22,000 Ohm - 20% 1/2 Watt	4502	.05
R4	2.2 Megohm - 20% 1/2 Watt	4502	.05
R5	10,000 Ohm - 10% 2 Watt	4502	.05
R6	10 Megohm - 20% 1/2 Watt	4505	.10
R7	5 Megohm - 20% 1/2 Watt	4504	.10
R8	5 Megohm Pentameter-Volume Control	4844	.80
R9	22 Megohm - 20% 1/2 Watt	4500	.05
R10, R11, R12	1 Megohm - 20% 1/2 Watt	4513	.05
R13, R14, R15	47,000 Ohm - 20% 1 Watt	4516	.09
R16	47,000 Ohm - 20% 1/2 Watt	4504	.05
R17, R18, R19	2,200 Ohm - 20% 1/2 Watt	4512	.05
R20	.25 Meg. Pot. with Switch-Treble Control	4805	1.38
R21	50,000 Ohm Potentiometer-Bass Control	4806	.75
R22, R23, R24	.47 Megohm - 20% 1/2 Watt	4506	.05
R25	220 Ohm - 20% 3 Watt	4519	.29
R26, R27, R28, R29	47,000 Ohm - 5% 1/2 Watt	4537	.11
R30	22,000 Ohm - 5% 1/2 Watt	4538	.11
S1	Band Change Switch	6005	2.81
S2	Pushbutton Switch Assembly	6004	2.92
S3	On-Off Switch (on Treble Control)	5220	1.18
T1, T2, T3	Antenna Coil (Band "A")	5217	1.68
T4, T5, T6	R.F. Coil Shielded (Band "A")	5216	1.45
T7, T8, T9	R.F. Coil (Bands "B" and "C")	5219	1.68
T10	Output I.F. Transformer	5213	2.15
T11	Output Transformer	5214	1.93
T12	Power Transformer	5001	10.08
T13	Audio Output Transformer	5108	2.68
Z1	Pushbutton Tuning Assembly	52200	4.40

*Prices subject to change without notice.

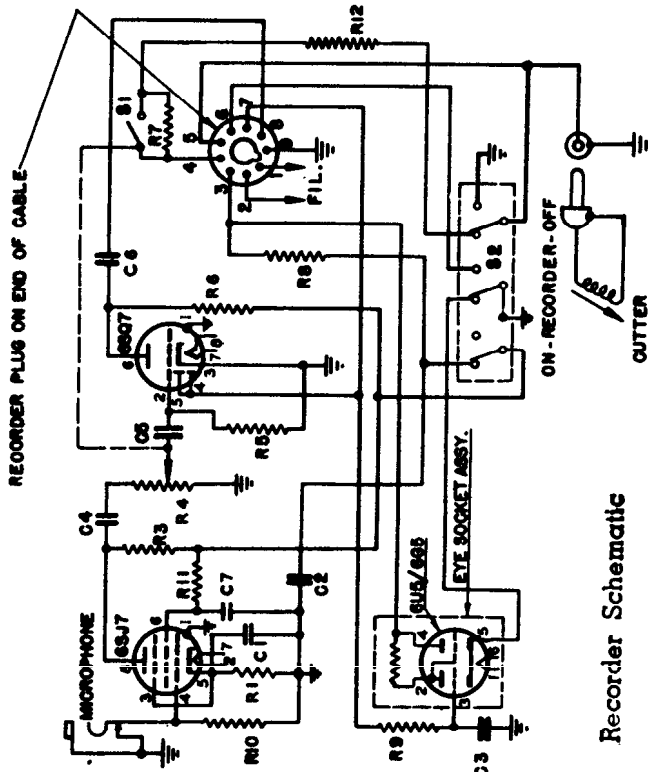

Recorder Schematic

SYMBOL	DESCRIPTION	HOFFMAN NO.	*List Price
C1, C2, C3, C4	25 Mfd.-25 Volt, Electrolytic	4205	.73
C5	10 Mfd. 450 Volt, Electrolytic	4203	1.24
C6	.01 Mfd. 400 Volt, Tubular Paper	4112	.19
C7	.005 Mfd. 400 Volt, Tubular Paper	4104	.21
R1	22 Mfd. 400 Volt, Tubular Paper	4106	.19
R2	10,000 Ohm ±20% 1/2 Watt	4512	.05
R3	2,200 Ohm ±20% 1/2 Watt	4515	.05
R4	5 Megohm ±20% 1 Watt	4506	.05
R5	10 Megohm ±20% 1/2 Watt	4802	1.09
R6	10 Megohm ±20% 1/2 Watt	4505	.05
R7	1.0 Ohm ±20% 1/2 Watt	4500	.05
R8	17,000 Ohm ±20% 1/2 Watt Wire Wound	4707	.13
R9, R10	1.0 Megohm ±20% 1/2 Watt	4516	.09
R11	1 Megohm ±20% 1/2 Watt	4513	.05
S1	Master On-off Switch (Part of R4)	4511	.05
S2	Power Transformer	6003	1.45
S3	.5 Ohm ±20% 1/2 Watt Wire Wound	4708	.06

MANUAL OF 1949 MOST-OFTEN-NEEDED RADIO DIAGRAMS

HOFFMAN RADIO CORPORATION

MODELS B508, B509 and B510
CHASSIS 129

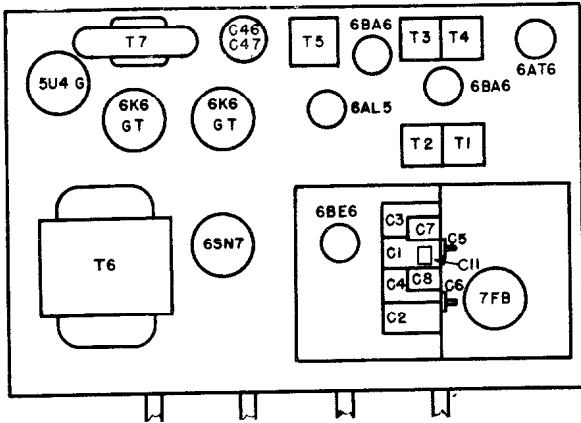
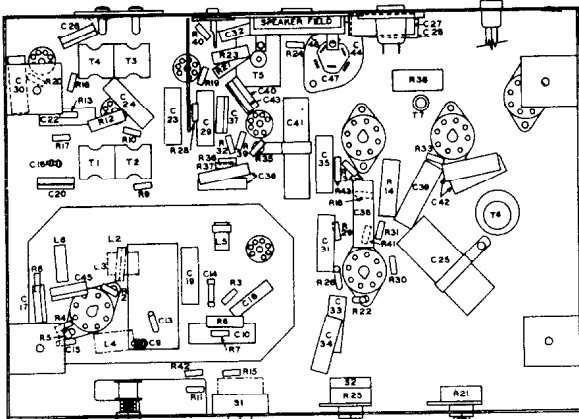

SYMBOL	DESCRIPTION	HOFFMAN NO.	LIST PRICE
C1, C2, C3, C4	4 Section Variable Trimmer (F.M. Section)	4409	\$3.96
C5, C6	8 Mmf. ±10%	4308	.80
C7, C8	Trimmer (A.M. Section)	4313	.20
C9, C18	8 Mmf. ±10%	4019	.24
C10, C23	.05 Mfd. 200 V.	4100	.21
C11	1.5 Mmf. ±20%	4008	.10
C12	220 Mmf. ±20%	4026	.30
C13	22 Mmf. ±10%	4021	1.00
C14, C26	100 Mmf. ±10%	4012	.18
C15, C17, C45	650 Mmf. ±20%	4011	.38
C16, C19, C21, C22, C24, C29, C30, C31	.01 Mfd. 400 V.	4112	.19
C20, C32	2300 Mmf. ±5%	4006	.63
C25	10 Mfd. 450 V.	4203	1.24
C27, C28	.01 Mfd. 600 V.	4103	.18
C33	.02 Mfd. 400 V.	4106	.19
C34	.005 Mfd. 600 V.	4102	.21
C35	.1 Mfd. 200 V.	4111	.22
C36, C42	.002 Mfd. 600 V.	4118	.20
C37, C40, C43	270 Mmf. ±20%	4001	.22
C38, C39	.05 Mfd. 400 V.	4101	.23
C41	5 Mfd. 50 V.	4209	.84
C44	20 Mfd. 25 V.	4200	2.28
C46, C47	20 Mfd. 450 V.		
R1, R33, R34	.47 Meg. ±20%	4506	.05
R2, R7, R28	22000 Ohm ±20%	4501	.05
R3	22 Ohm ±20%	4560	.13
R4	68 Ohm ±20%	4524	.05
R5	1200 Ohm ±10%	4553	.05
R6	15000 Ohm ±20%	4539	.08
R8, R9, R13, R24	1500 Ohm ±20%	4534	.05
R10, R19	56 Ohm ±10%	4561	.05
R11, R15, R20	2.2 Meg. ±20%	4502	.05
R12, R23	33000 Ohm ±20%	4556	.60
R14	2200 Ohm ±20%	4540	.08
R16	1 Meg. ±20%	4511	.05
R17, R17	.1 Meg. ±20%	4500	.08
R18, R40, R41	.22 Meg. ±20%	4804	.80
R21	.5 Meg. Pot. (Volume Control)	4513	.05
R22	1.0 Meg. ±20%	4805	1.05
R25	.25 Meg. Pot. (Tone Control)	4512	.05
R26	2200 Ohm ±20%	4546	.05
R27	120 Ohm ±10%	4543	.04
R29	4700 Ohm ±20%	4559	.40
R30, R31	4700 Ohm ±10%	4504	.05
R32	4700 Ohm ±20%	4549	.05
R35, R39	390 Ohm ±10%	4557	.10
R36, R37	6800 Ohm ±10%	4517	.05
R38	400 Ohm ±20%	5279	1.80
L1	A.M. Loop Antenna	5281	
L2	F.M. Antenna Primary Coil	5283	
L3	F.M. Antenna Secondary Coil	5280	
L4	F.M. Oscillator Coil	5282	
L5	A.M. Oscillator Coil	5266	.60
L6	Filament Choke	5274	2.10
T1	1st. F.M. I.F. Transformer	5276	2.00
T2	1st. A.M. I.F. Transformer	5275	2.10
T3	2nd. F.M. I.F. Transformer		

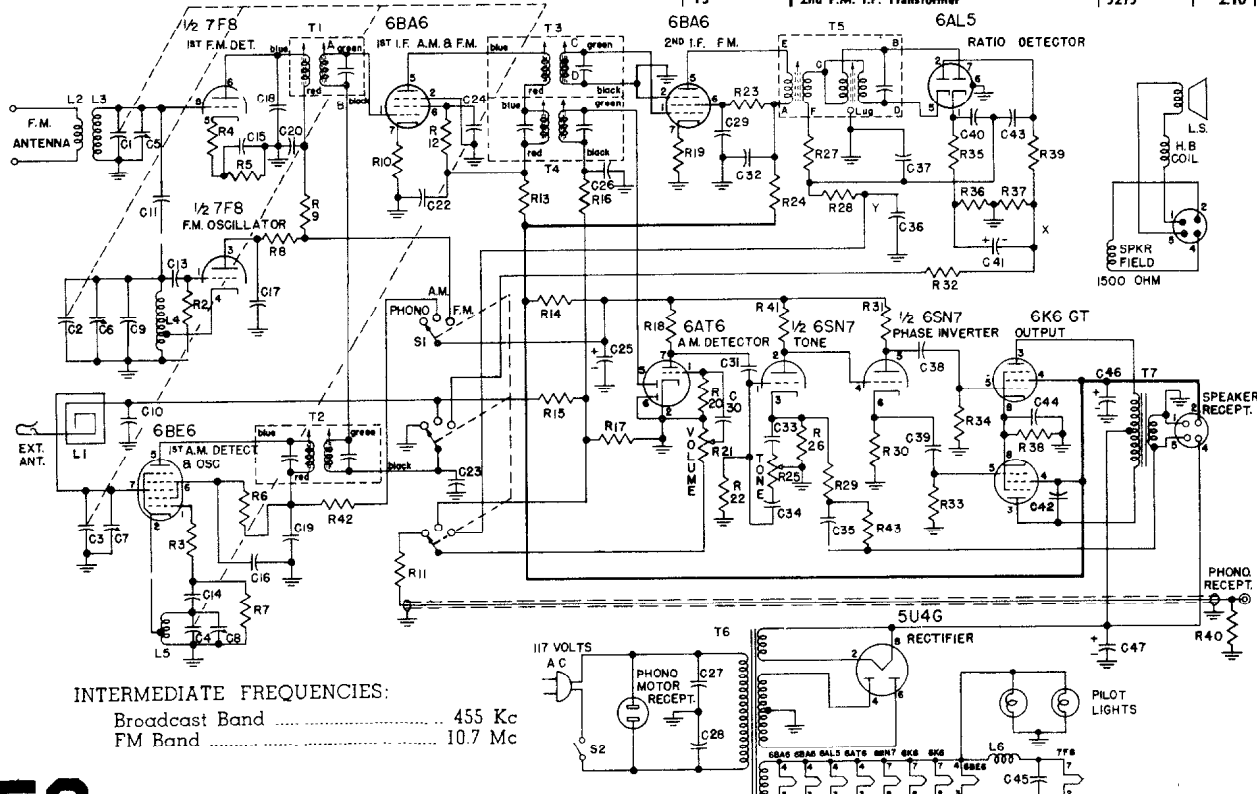

INTERMEDIATE FREQUENCIES:
Broadcast Band 455 Kc
FM Band 10.7 Mc

MANUAL OF 1949 MOST-OFTEN-NEEDED RADIO DIAGRAMS

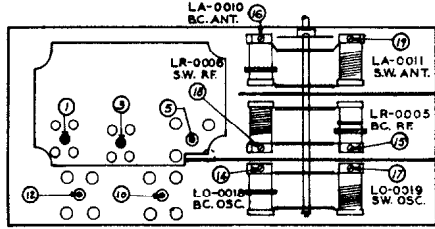

TRIMMER LOCATION CHARTS

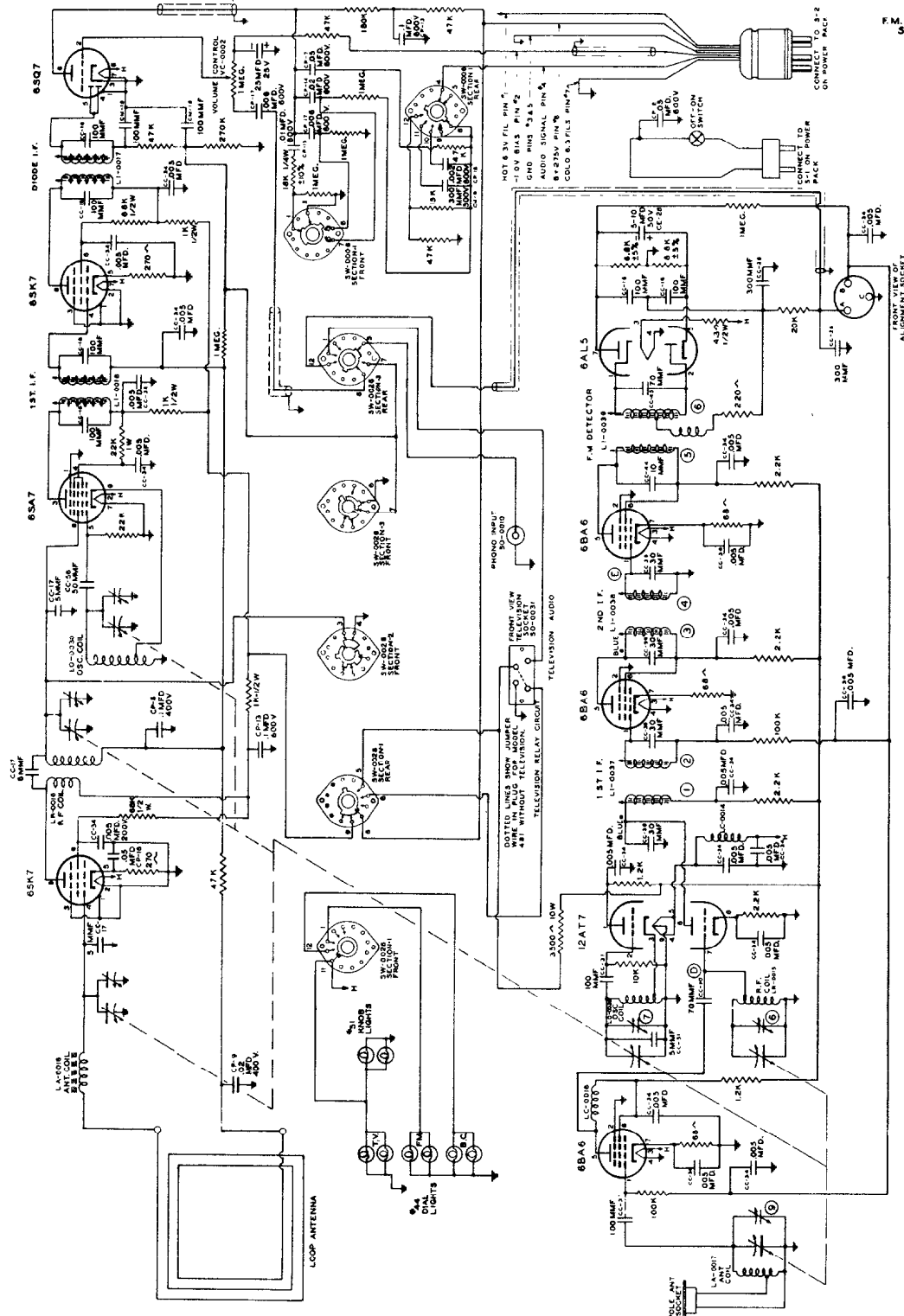
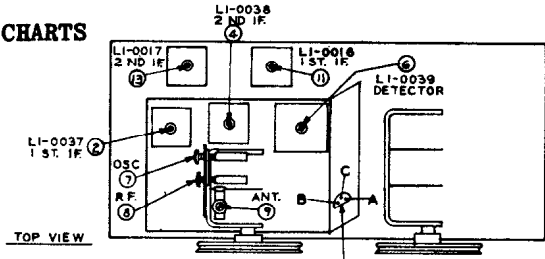

HOWARD RADIO

MODEL 481-A (Chassis)

The HOWARD 481-A Chassis, is essentially the same as the 481-M, 481-B and 481-C, the only difference is that the Short Wave is not included in this model.

- NOTES—
- 1 SW-0028—THREE SECTION—FOUR POSITION BAND SWITCH SHOWN IN POSITION NO. 1 POSITION IS PHONO BROADCAST NO. 2 POSITION IS F.M. BROADCAST
 - 2 SW-0028 ONE SECTION—FIVE POSITION TONE SWITCH SHOWN IN "FULL" POSITION
 - 3 ALL SWITCH SECTIONS SHOWN IN COUNTER-CLOCKWISE POSITION AS VIEWED FROM FRONT END OF UNIT
 - 4 R.F. COILS ARE 205-1/4W UNLESS OTHERWISE SPECIFIED.
 - 5 1/2 1000 OHMS

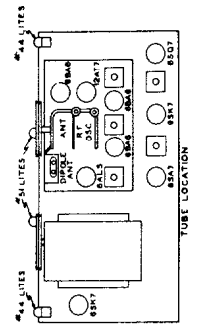

MANUAL OF 1949 MOST-OFTEN-NEEDED RADIO DIAGRAMS

Meissner F.M. Receptor, Model 8C

Intermediate Frequency - 10.7
megacycles

Tuning range - 88 to 108
megacycles

Voltage Chart - The voltages tabulated in the table below are the correct voltages which should be measured between the socket terminal and chassis with nominal line voltage and no signal. All voltages measured with a high impedance voltmeter.

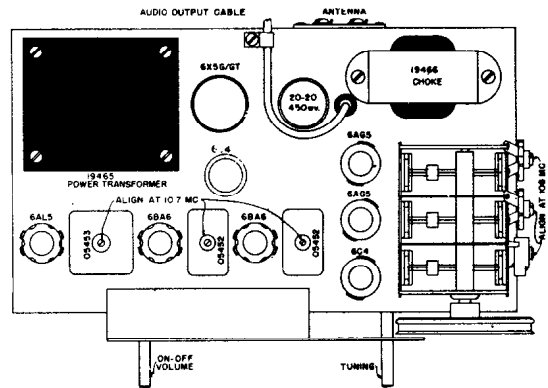

VOLTAGE CHART

Terminal Number	1	2	3	4	5	6	7	8
6AG5 1st Converter	0	2.1	6.3V RMS	0	260	63	2.1	
6AG5 2nd Converter	0	1.2	6.3V RMS	0	270	37	1.2	
6C4 Oscillator	184	0	6.3V RMS	0	184	—	0	
6BA6 1st I.F. Amp	0.4	0	6.3V RMS	0	95	95	0.95	
6BA6 2nd I.F. Amp	0	0	6.3V RMS	0	84	84	0.95	
6AL5 Detector	0	0	6.3V RMS	0	0	0	0	
6C4 Audio	105	0	6.3V RMS	0	150	0	3.4	
6X5GT/G Rectifier	NC	0	240V RMS	Tie Point	240V RMS	Tie Point	6.3V RMS	287

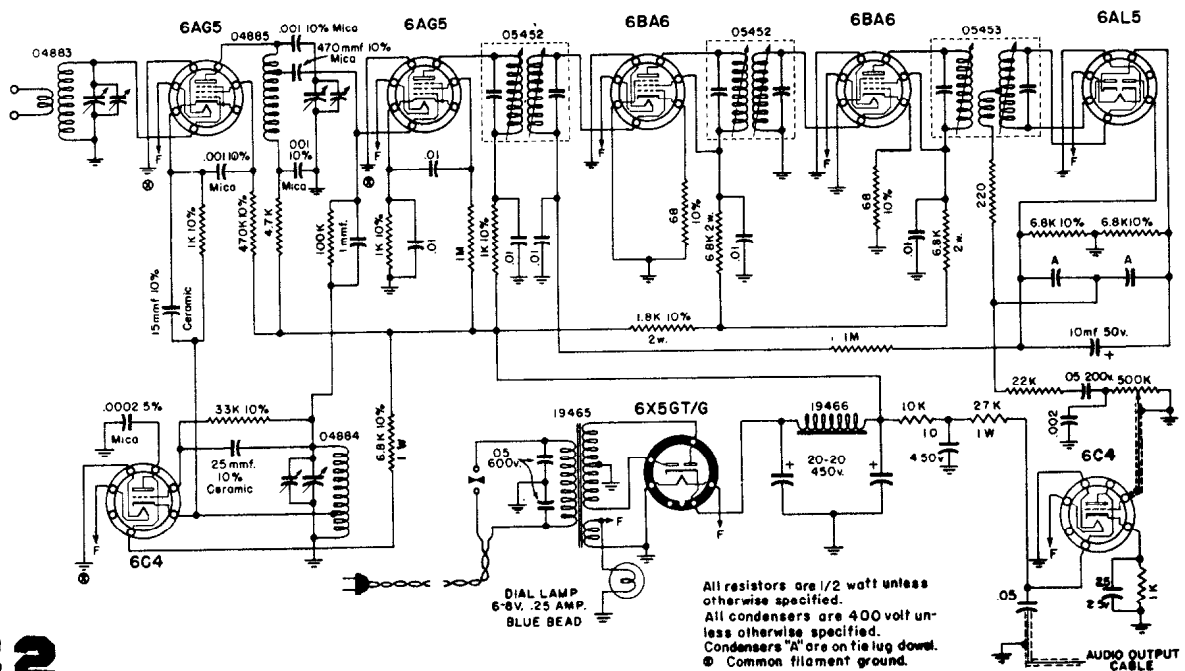

MANUAL OF 1949 MOST-OFTEN-NEEDED RADIO DIAGRAMS

WARDS *Airline* RADIO 84GCB-1062A

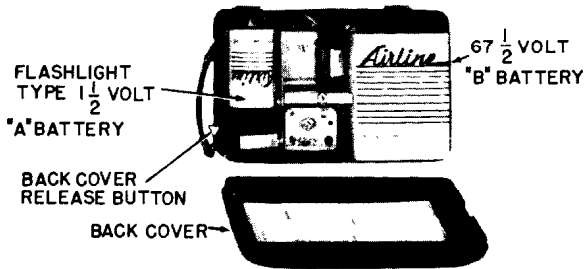

ALIGNMENT PROCEDURE AND RECEIVER STAGE SENSITIVITIES

The signal source must be an accurately calibrated signal generator capable of supplying R.F. signals modulated 30% with a 400-cycle audio signal. A 400-cycle source is necessary for the audio measurements.

In order to make the adjustments listed in the table below, it is necessary to first remove the front panel in order to remove the chassis from the cabinet. The loop leads must also be disconnected (unsolder) and extended by means of short leads. The table below

lists the sensitivity at various points. All measurements are based on an output of 50 milliwatts. This may be measured by disconnecting the speaker voice coil and substituting a 3.2 ohm, 5 watt resistor across the secondary winding of the output transformer. A reading of .4 volts AC across this resistor will be equivalent to a 50-milliwatt output with the speaker connected. Variations of plus or minus 25% are usually permissible. Volume control at maximum for all adjustments.

SIGNAL GENERATOR				DIAL SETTING	ADJUST FOR MAXIMUM OUTPUT	INPUT FOR 50-MILLIWATT OUTPUT
Frequency	Coupling	Connection to Radio	Ground Connection			
455 KC	.1 mfd condenser	Stator lug Var. Capacitor (front section)	Chassis	Variable Condenser fully open	Trimmers 1st and 2nd I.F. transformer	100 microvolts
1650 KC	Coupling loop see note 1	None	None	Variable Condenser fully open	Oscillator Trimmer (Rear section)	-----
1500 KC	Coupling loop see note 2	None	None	1500 KC	Ant. trimmer (front section)	-----
400 cycles	.1 mfd condenser	High side of volume control	Chassis	-----	-----	.045 volts

Note 1 - Connect signal generator leads to a three turn radiating loop approximately 4" in diameter placed about 8" from the loop of the receiver.

Note 2 - After chassis is installed in cabinet and re-connected to its loop re-adjust the antenna trimmer by ear, with low signal input.

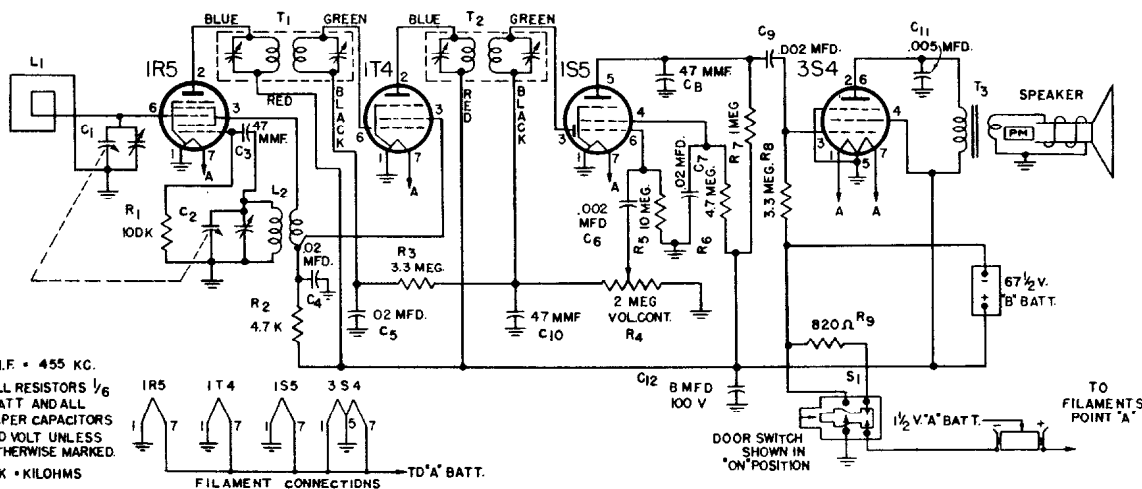
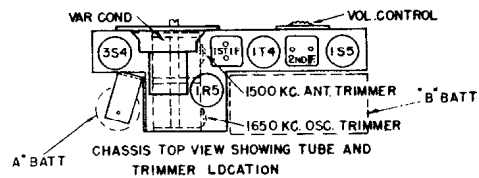

MANUAL OF 1949 MOST-OFTEN-NEEDED RADIO DIAGRAMS

M O N T G O M E R Y W A R D

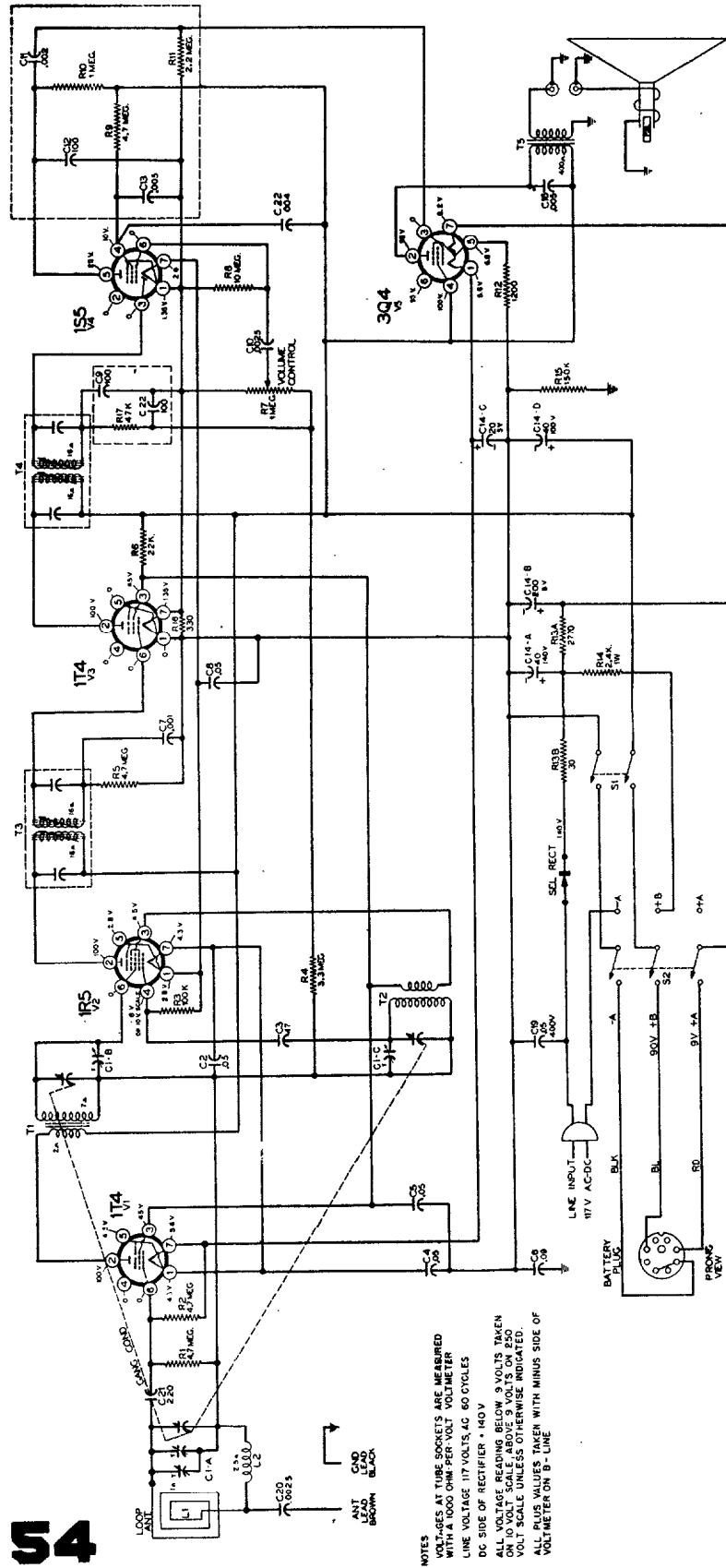

NOTES
 ALL TUBE SOCKETS AT TUBE SOCKETS ARE MARKED WITH A 100 OHM PER VOLT VOLTMETER LINE VOLTAGE (17 VOLTS AC, 80 CYCLES DC SIDE OF RECTIFIER - 110V 1A VOLTAGE READING) OR VOLTS ON 250 VOLT SCALE UNLESS OTHERWISE INDICATED. ALL PLUS VALUES TAKEN WITH MINUS SIDE OF VOLTMETER ON B- LINE

Frequency Range..... 535 to 1600 kc.
 Intermediate Freq..... 455 kc.

WARDS
84BR-1065A

CAUTION—The I.F. transformer construction is such that two resonance peaks occur for each winding, one peak when the slug is above its coil and another peak when the slug is below its coil. Be sure the upper cores are above the top coils and the lower cores are below the bottom coils (see coil drawing).

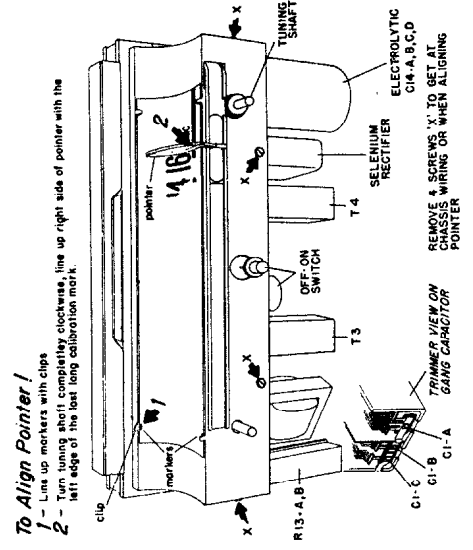
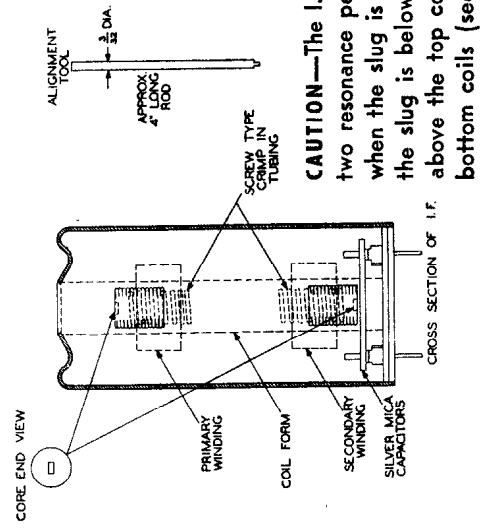

MANUAL OF 1949 MOST-OFTEN-NEEDED RADIO DIAGRAMS

M O N T G O M E R Y W A R D

74BR-1501B, 1502B

ALIGNMENT PROCEDURE AND RECEIVER STAGE SENSITIVITIES

The signal source must be an accurately calibrated signal generator capable of supplying R. F. signals modulated 30% with a 400-cycle audio signal. A 400-cycle source is necessary for the audio measurement.

The table below lists the sensitivity at various points. All measurements are based on an output of 50-milliwatts. This may be measured by disconnecting the

speaker voice coil and substituting a 3.2-ohm, 5-watt resistor across the secondary winding of the output transformer. A reading of .4 volts AC across this resistor will be equivalent to a 50-milliwatt output with the speaker connected. Variations of plus or minus 25% are usually permissible. Volume control at maximum for all adjustments.

SIGNAL GENERATOR				TUNER SETTING	ADJUST FOR MAXIMUM OUTPUT	INPUT FOR 50-MILLIWATT OUTPUT
Frequency	Coupling Capacitor	Connection to Radio	Ground Connection			
455 kc	.1 mf	Metal antenna plate	12SQ7 Pin 3	Iron cores all the way out	Trimmers on output and input I.F. cans	_____
1720 kc	.1 mf	Metal antenna plate	12SQ7 Pin 3	Iron cores all the way out	Oscillator trimmer C6	_____
1720 kc	200 mmf	External antenna clip	12SQ7 Pin 3	Iron cores all the way out	Antenna trimmer C3	_____
1400 kc	200 mmf	External antenna clip	12SQ7 Pin 3	1400 kc	Adjust position of ant. coil (see coil illustration view)	31 microvolts
1720 kc	200 mmf	External antenna clip	12SQ7 Pin 3	1720 kc	Antenna trimmer C3 ^e	31 microvolts
1000 kc	200 mmf	External antenna clip	12SQ7 Pin 3	1000 kc	_____	28 microvolts
455 kc	.1 mf	12SA7, Pin 8	12SQ7 Pin 3	Iron cores all the way out	_____	82 microvolts
400 cycles	.1 mf	12SQ7, Pin 2	12SQ7 Pin 3	_____	_____	.05 volts

*After the antenna coil has been tracked at 1400 kc, it is necessary to check the antenna trimmer C3 again at 1720 kc. If no appreciable change in trimmer adjustment is necessary, the coil is in track. If the trimmer

requires considerable change, the position of the antenna coil at 1400 kc must be readjusted. These two adjustments should be made several times, until no trimmer adjustment is required at 1720 kc.

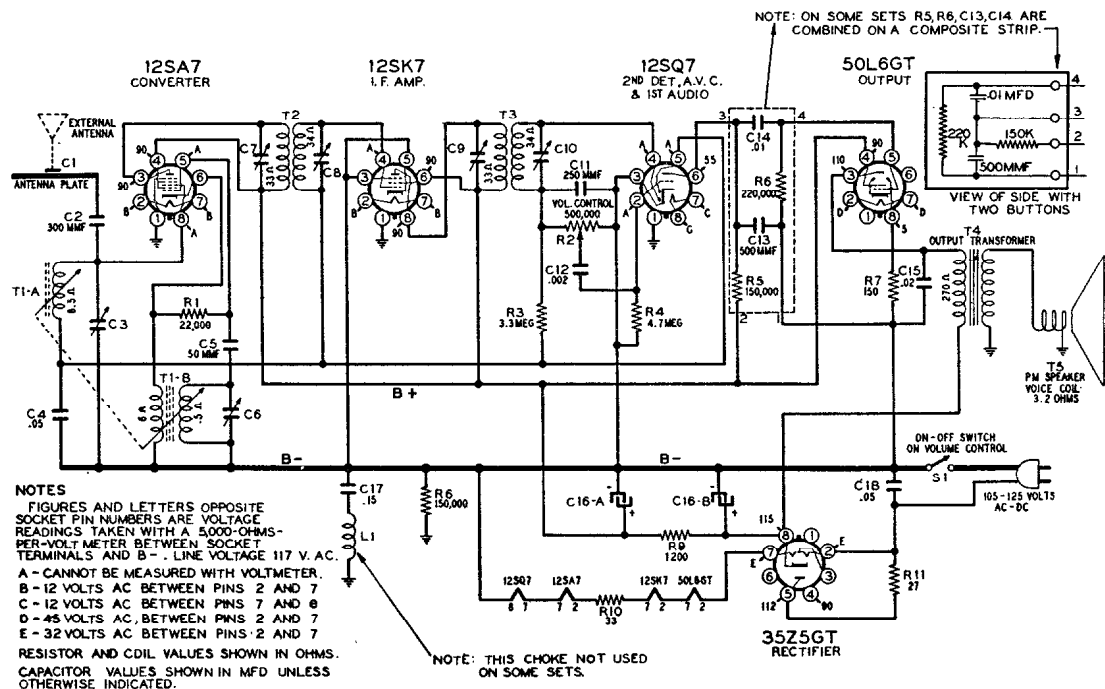

NOTES: On some sets dual trimmer C3, C6 is grounded to chassis instead of to B- as shown above. On some sets R6 is 470K ohms and R5 is 220K ohms. On some sets R10 is not used.

WARDS *Airline* RADIO

MODELS 84BR-1503D, 1504D

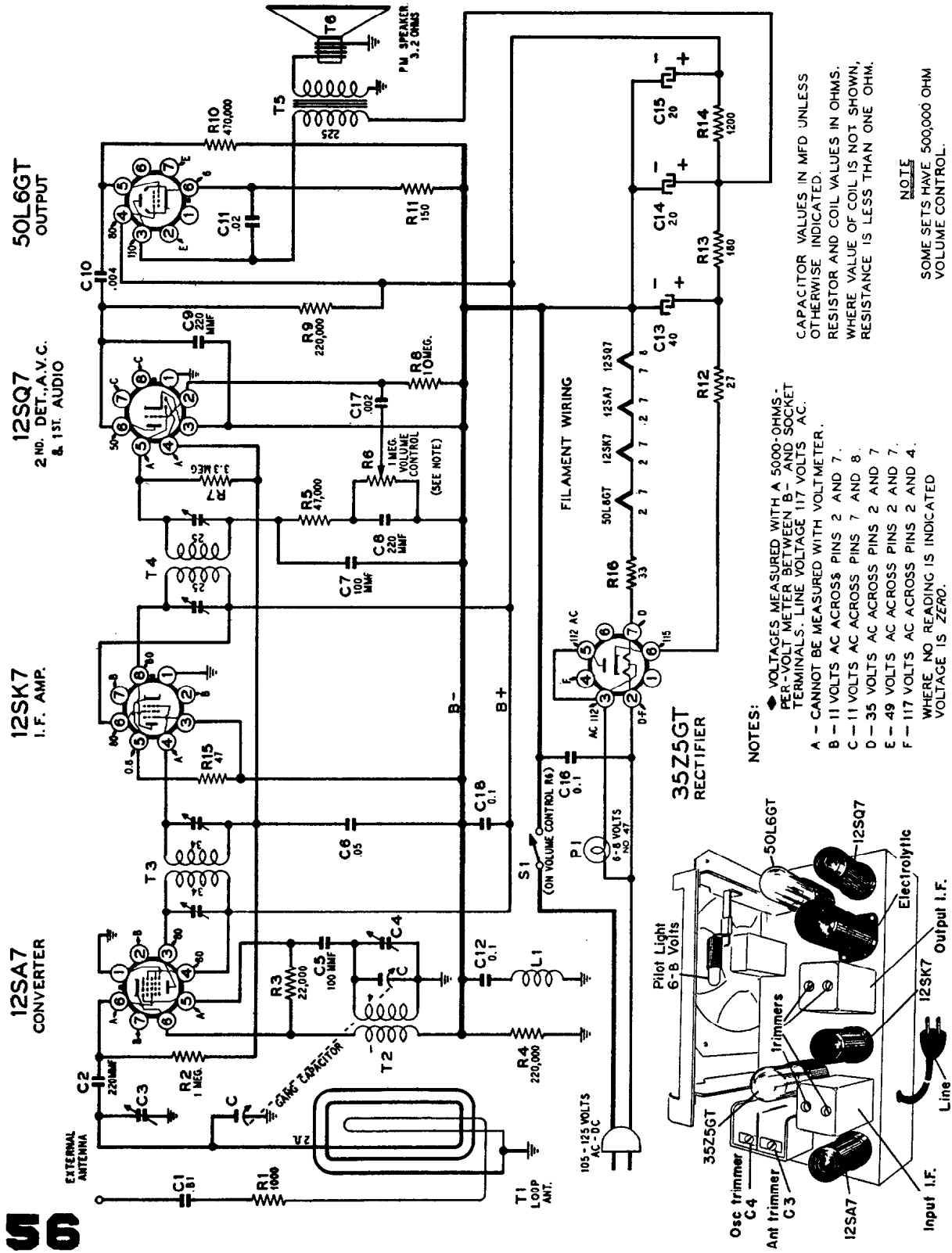

NOTES:

- ◆ VOLTAGES MEASURED WITH A 5000-OHMS PER-VOLT METER BETWEEN B- AND SOCKET TERMINALS. LINE VOLTAGE 117 VOLTS AC.
- A - CANNOT BE MEASURED WITH VOLTMETER.
- B - 11 VOLTS AC ACROSS PINS 2 AND 7.
- C - 11 VOLTS AC ACROSS PINS 7 AND 8.
- D - 35 VOLTS AC ACROSS PINS 2 AND 7.
- E - 49 VOLTS AC ACROSS PINS 2 AND 7.
- F - 117 VOLTS AC ACROSS PINS 2 AND 4. WHERE NO READING IS INDICATED VOLTAGE IS ZERO.

NOTE:
SOME SETS HAVE 500,000 OHM VOLUME CONTROL.

NOTE: On some sets the B+ lead of the second I.F. is connected to C14 instead of C15.

Frequency Range 530 to 1630 kc.
Intermediate Freq. 455 kc.

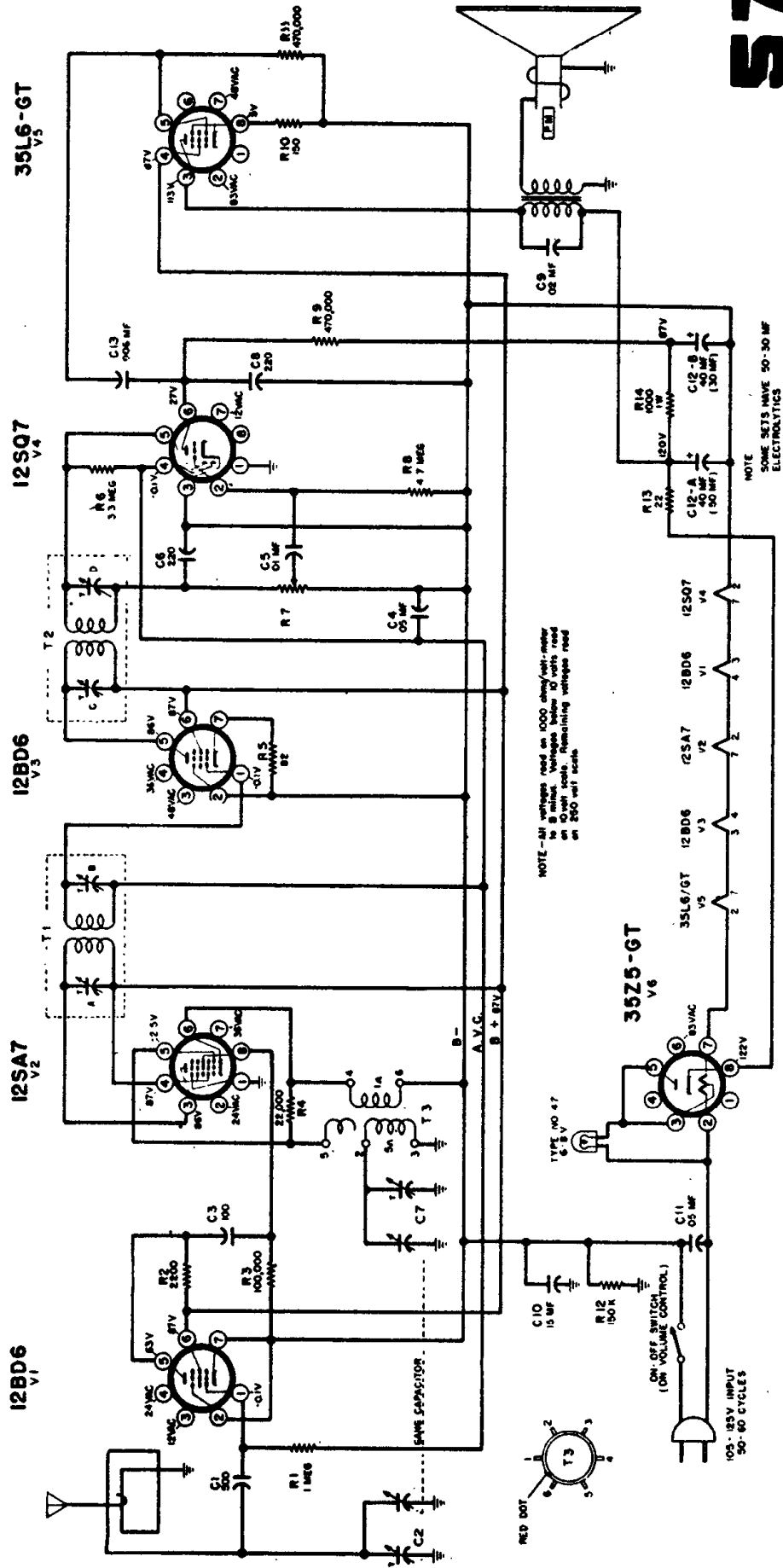

NOTE - All voltages read on 1000 ohm/volt-meter to B minus. Voltages below 10 volts read on 10 volt scale. Remaining voltages read on 250 volt scale.

NOTE
SOME SETS HAVE 50-50 MF
ELECTROLYTICS

MANUAL OF 1949 MOST-OFTEN-NEEDED RADIO DIAGRAMS

WARDS 84BR-1507B, 1508B

ALIGNMENT PROCEDURE

The signal source must be an accurately calibrated signal generator capable of supplying R. F. signals modulated 30% with a 400-cycle audio signal. A 400-cycle source is necessary for the audio measurement.

The table below lists the sensitivity at various points. All measurements are based on an output of 50-milliwatts. This may be measured by disconnecting the

speaker voice coil and substituting a 3.2-ohm, 5-watt resistor across the secondary winding of the output transformer. A reading of .4 volts AC across this resistor will be equivalent to a 50-milliwatt output with the speaker connected. Variations of plus or minus 25% are usually permissible. Volume control at maximum for all adjustments.

SIGNAL GENERATOR			TUNER SETTING	ADJUST FOR MAXIMUM OUTPUT	INPUT FOR 50-MILLIWATT OUTPUT
Frequency	Coupling Capacitor	Connection to Radio			
455 kc.	.1 mf.	Pin No. 8 of 12SA7	Rotor full open	Trimmers on output and input I.F. cans	100 microvolts
1650 kc.	.1 mf.	Pin No. 8 of 12SA7	Rotor full open	Oscillator trimmer C7 (on bottom)	_____
1400 kc.	none	See note A	Set dial at 1400	Antenna trimmer C2 (on bottom)	_____
1400 kc.	.1 mf.	External antenna clip	1400 kc.	_____	13 microvolts
400 cycles	.1 mf.	12SQ7, Pin 2	_____	_____	.05 volts

Note A: Lay output lead of generator in back of loop antenna.

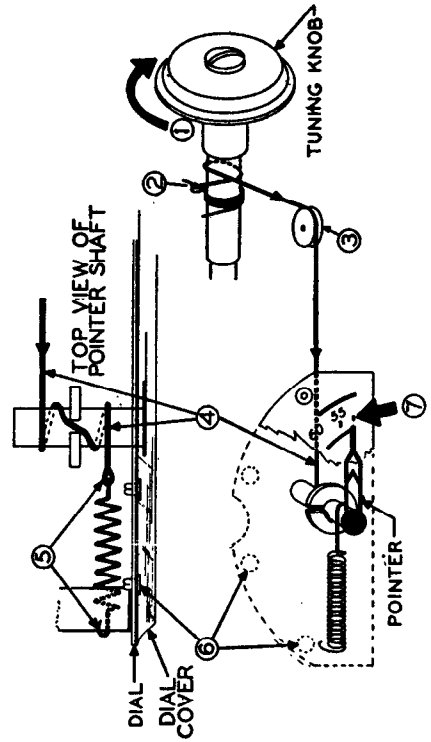

NOTE: On some sets slug tuned I.-F.'s are used instead of trimmer tuned I.-F.'s. 108-140H and 108-145 are trimmer tuned. B-13A-12023 and B-13B-12022 are slug tuned. The slug tuned I.-F.'s

Turn up generator output. Loop antenna will pick up energy.

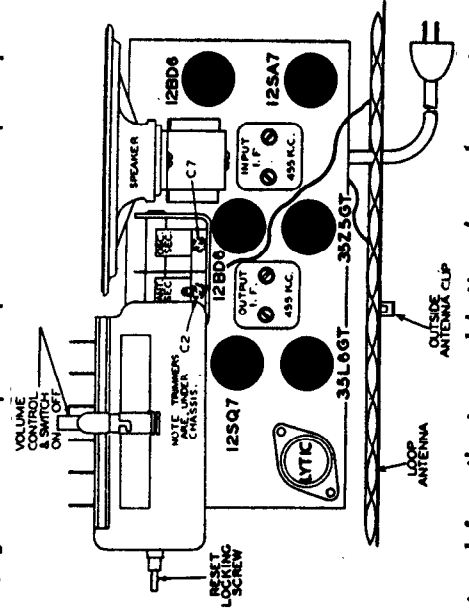

are tuned from the top and bottom (secondary on top, primary on bottom).

When slug tuned I.-F.'s are used, R5 is 270 ohms.

MANUAL OF 1949 MOST-OFTEN-NEEDED RADIO DIAGRAMS

M O N T G O M E R Y W A R D

MODEL 84BR-2003C

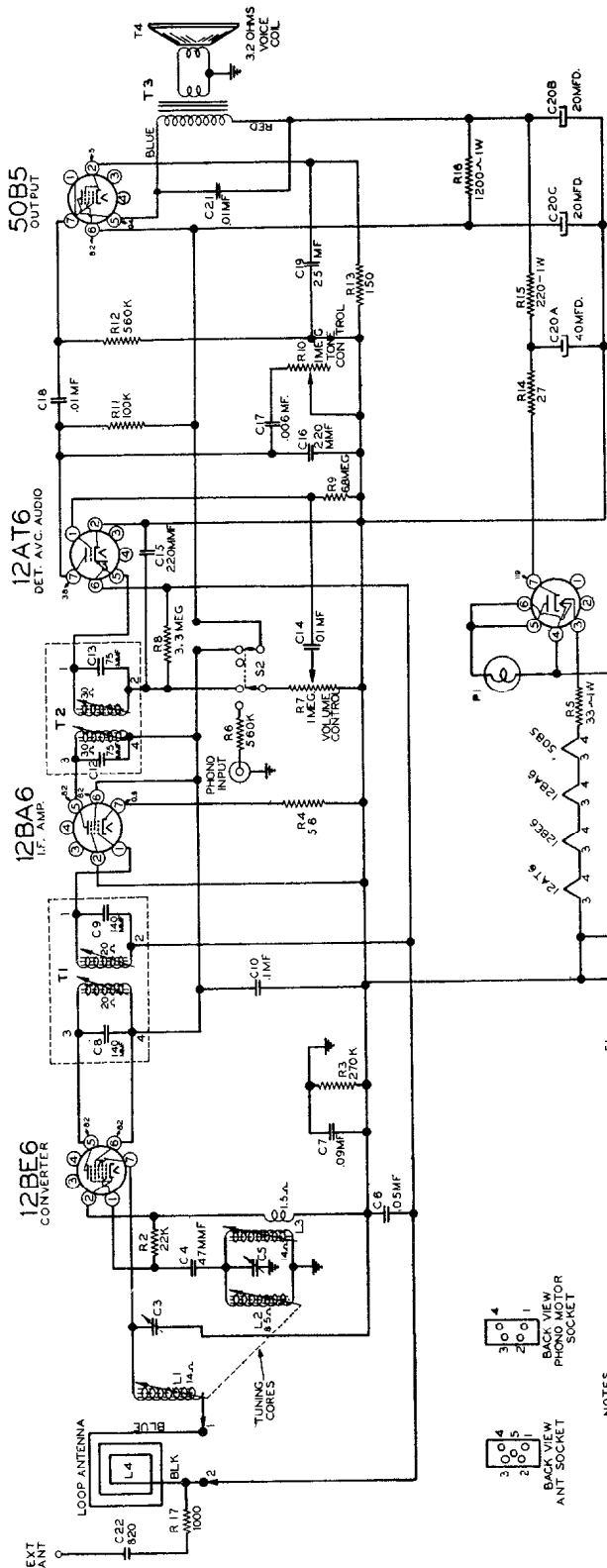

Frequency Range..... 535 to 1620 kc.
Intermediate Freq..... 455 kc.

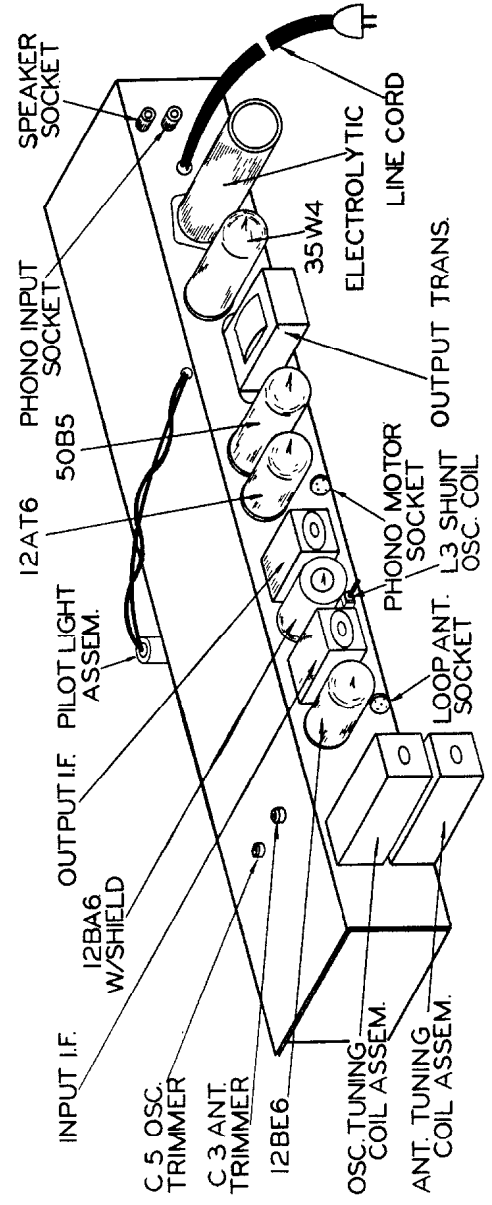
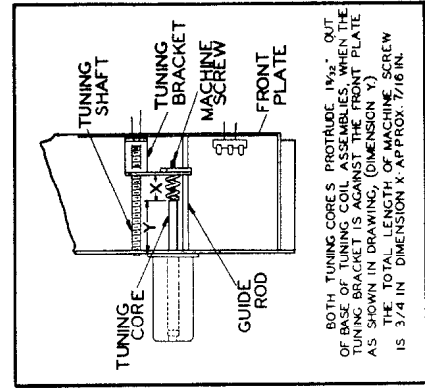

NOTES
S1 ON REAR OF VOLUME CONTROL
S2 IS THE RADIO-PHONO SWITCH, SHOWN IN RADIO POSITION.
ALL RESISTORS ARE 1/2 WATT UNLESS OTHERWISE NOTED
DC SOCKET VOLTAGE READINGS ARE TAKEN BETWEEN PINS DESIGNATED AND "B" LINE VOLTAGE 117 A.C.
VOLTAGES SHOWN ARE DC UNLESS OTHERWISE INDICATED

NOTE: On some sets, the loop antenna socket is eliminated and leads are brought out thru the hole.



MANUAL OF 1949 MOST-OFTEN-NEEDED RADIO DIAGRAMS

M O N T G O M E R Y W A R D

MODEL 84 WG-2704D

Frequency Range.....B range—540-1600 KC
D range—5.75 to 18.3 MC
Intermediate Frequency..455 KC

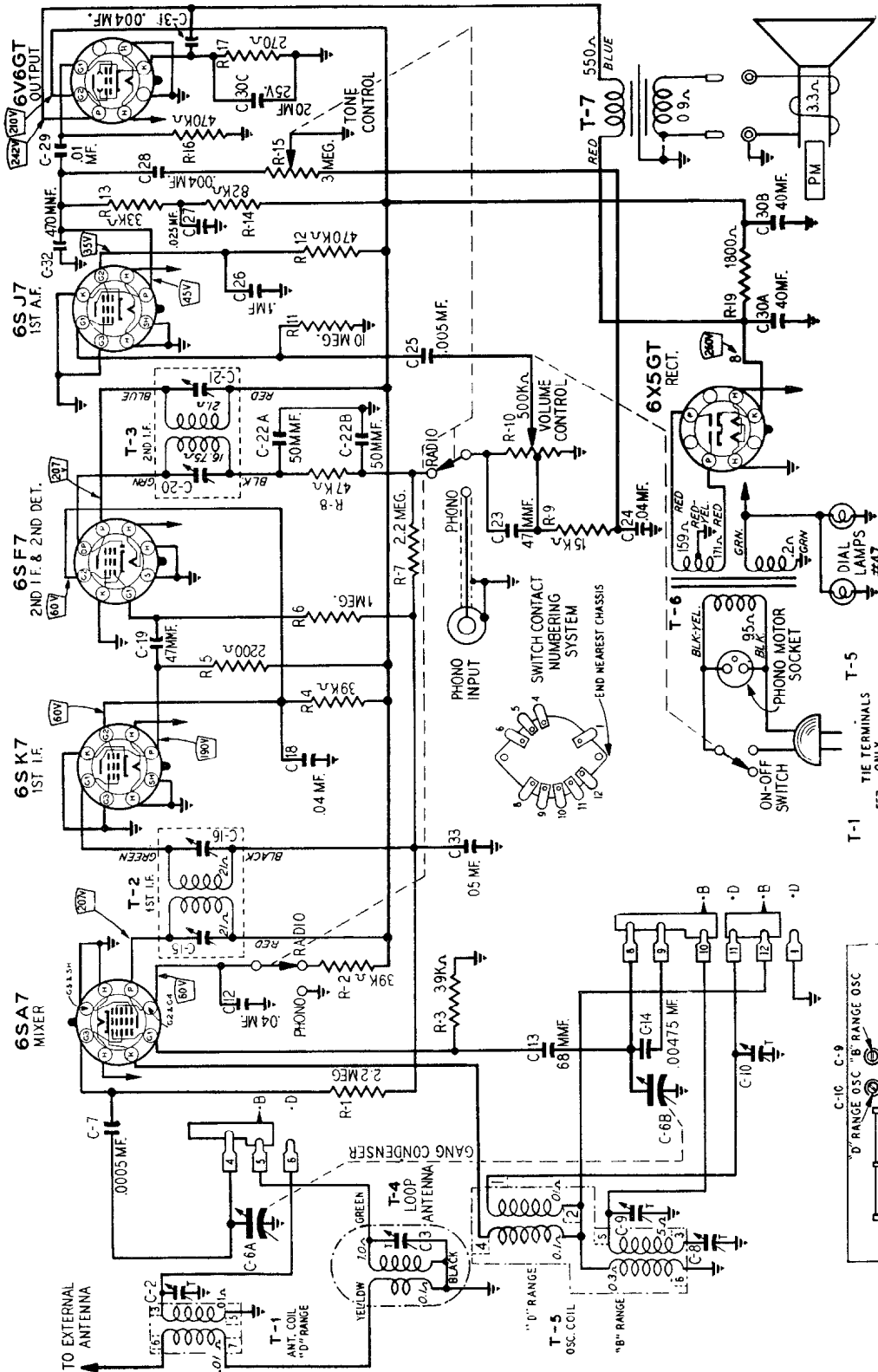

TUBE SOCKET VOLTAGES

The readings were taken with a 1000 ohm per volt meter and all plate and screen voltages read on a 500 volt scale. Conditions of measurement are:

Line voltage.....117 volts AC
Volume control.....maximum
Signal input.....none
A variation of ±10% is usually permissible.

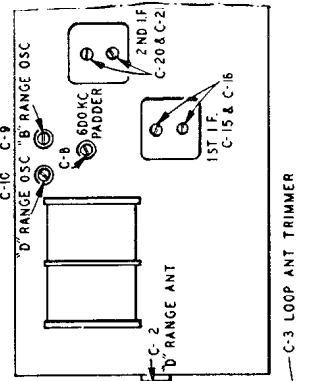
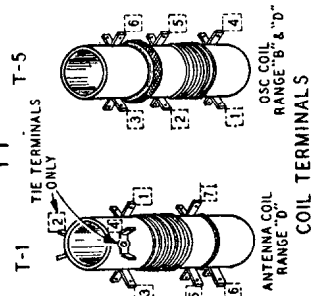

MANUAL OF 1949 MOST-OFTEN-NEEDED RADIO DIAGRAMS

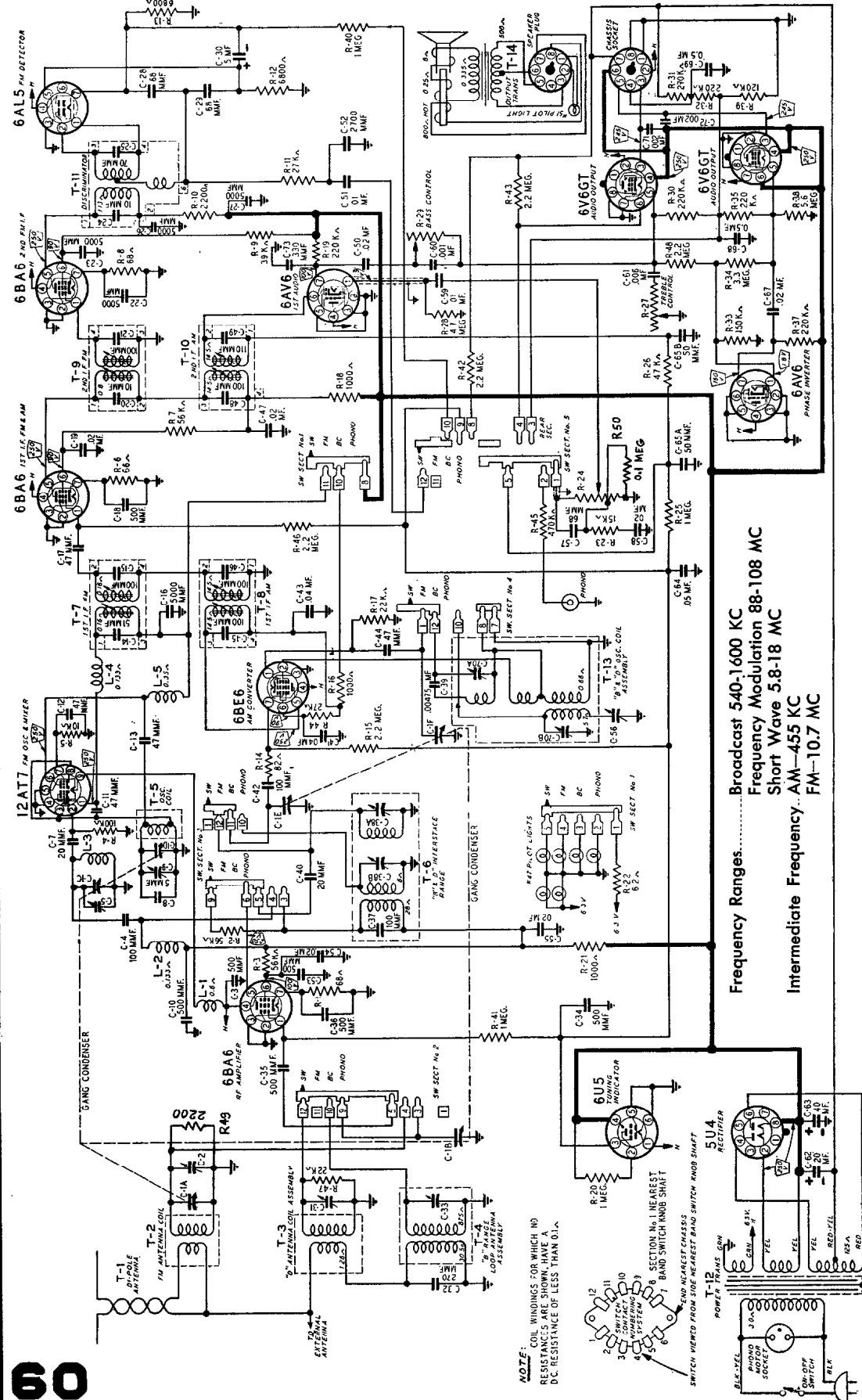

60

NOTE: COIL WINDINGS FOR WHICH NO RESISTANCES ARE SHOWN, HAVE A DC RESISTANCE OF LESS THAN 0.1 A.

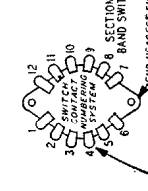

WARDS - Airline RADIO

MODEL 84WG-2712A

WARDS

MODEL 84WG-2714G

Intermediate Frequency...AM—455KC
FM—10.7 MC

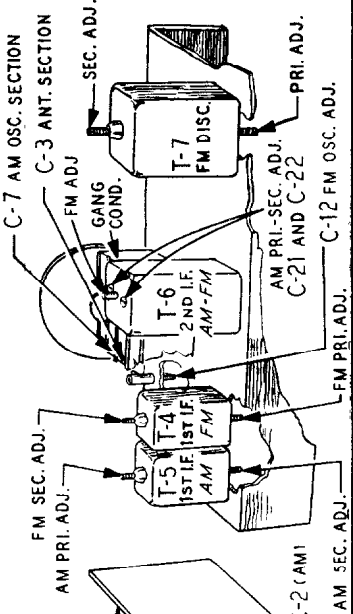
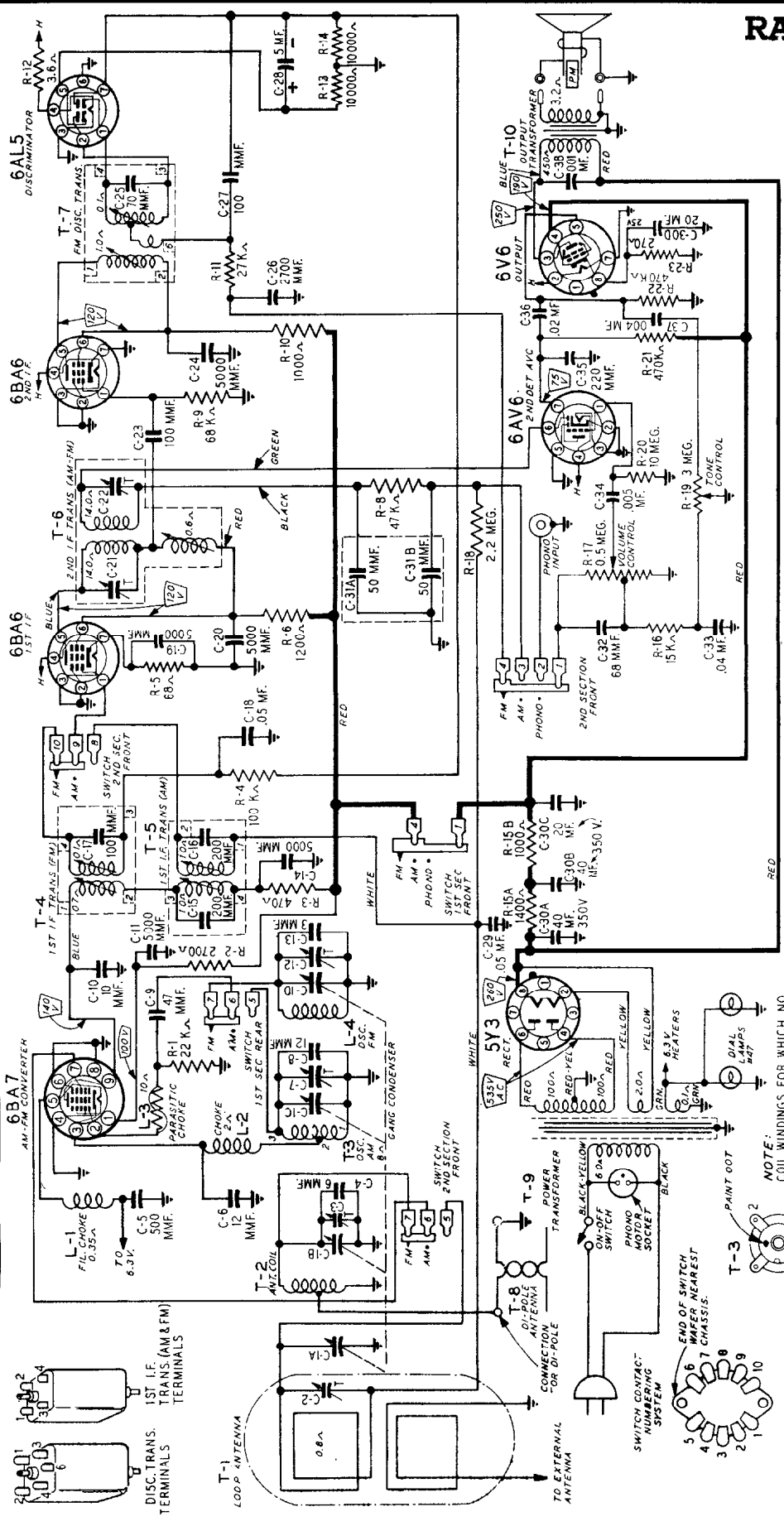

NOTE: COIL WINDINGS FOR WHICH NO RESISTANCES ARE SHOWN HAVE A D.C. RESISTANCE OF LESS THAN 0.1.

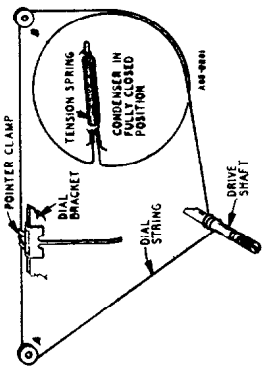
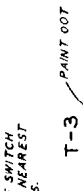

MANUAL OF 1949 MOST-OFTEN-NEEDED RADIO DIAGRAMS

W A R D MODEL 84WG-2721C

Intermediate Frequency... AM—455KC
FM—10.7 MC

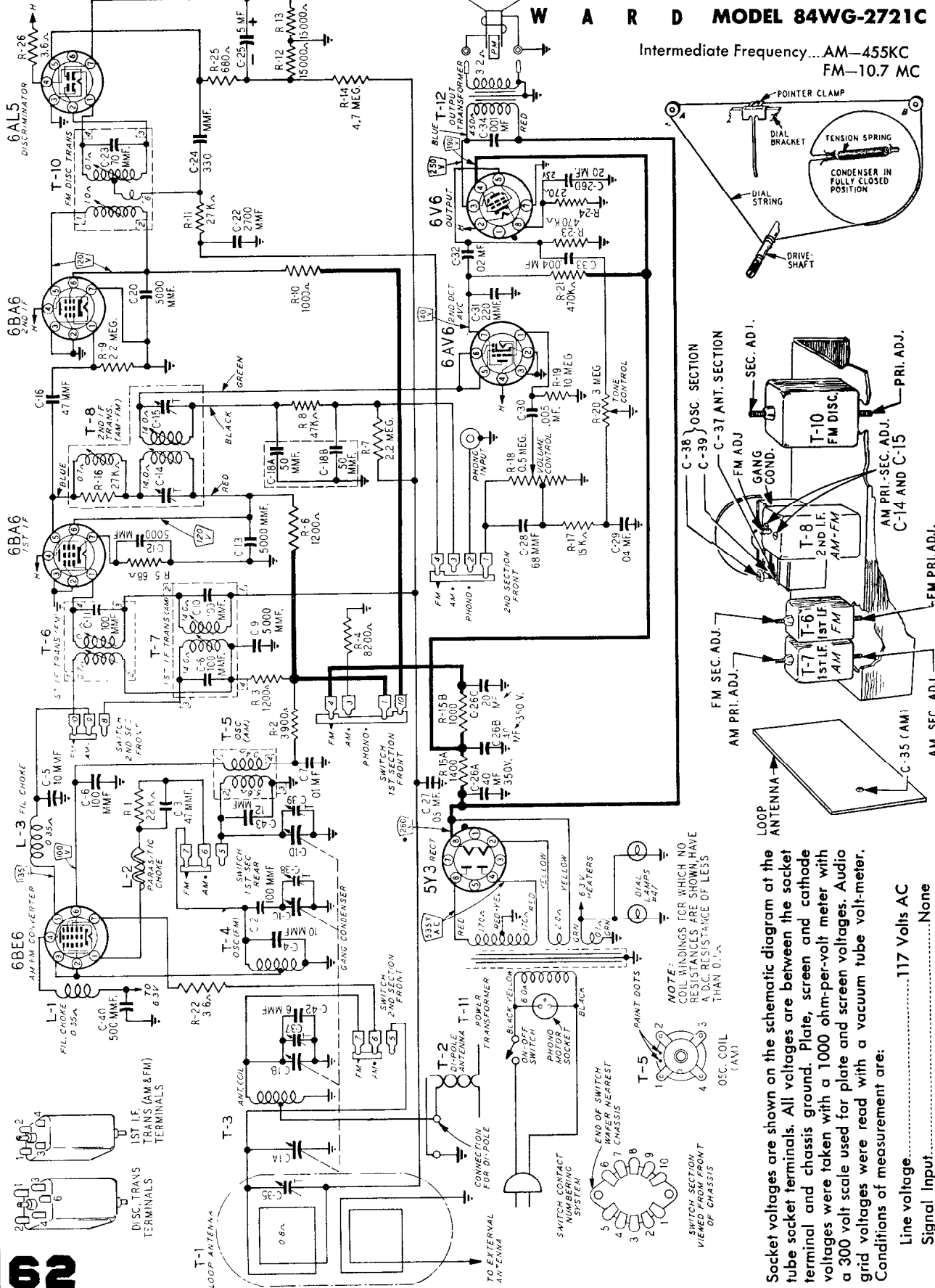

NOTE: COIL WINDINGS FOR WHICH NO RESISTANCES ARE SHOWN HAVE A D.C. RESISTANCE OF LESS THAN 0.1 Ω.



Socket voltages are shown on the schematic diagram at the tube socket terminals. All voltages are between the socket terminal and chassis ground. Plate, screen and cathode voltages were taken with a 1000 ohm-per-volt meter with a 300 volt scale used for plate and screen voltages. Audio grid voltages were read with a vacuum tube volt-meter. Conditions of measurement are:

- Line voltage.....117 Volts AC
- Signal Input.....None

MANUAL OF 1949 MOST-OFTEN-NEEDED RADIO DIAGRAMS

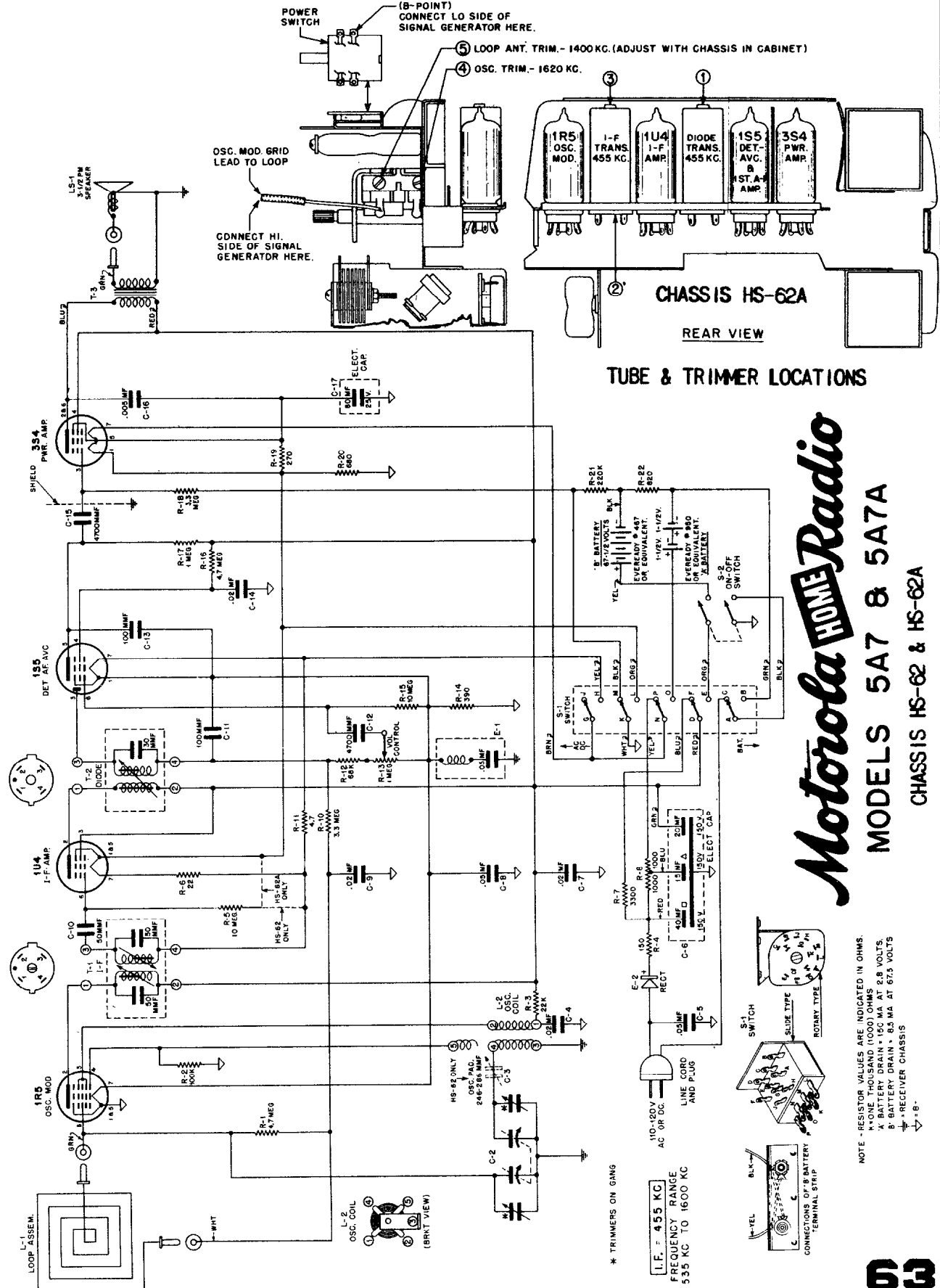

TUBE & TRIMMER LOCATIONS

Motorola Home Radio

MODELS 5A7 & 5A7A

CHASSIS HS-62 & HS-62A

I.F. = 455 KC
 FREQUENCY RANGE
 535 KC TO 1600 KC

NOTE - RESISTOR VALUES ARE INDICATED IN OHMS.
 K = ONE THOUSAND (1000) OHMS
 M = MILLI (0.001) OHMS
 X = BATTERY DRAIN - 150 MA. AT 2.8 VOLTS.
 B = BATTERY DRAIN - 85 MA. AT 67.5 VOLTS.
 ↓ = RECEIVER CHASSIS
 ⇩ = B.

MANUAL OF 1949 MOST-OFTEN-NEEDED RADIO DIAGRAMS

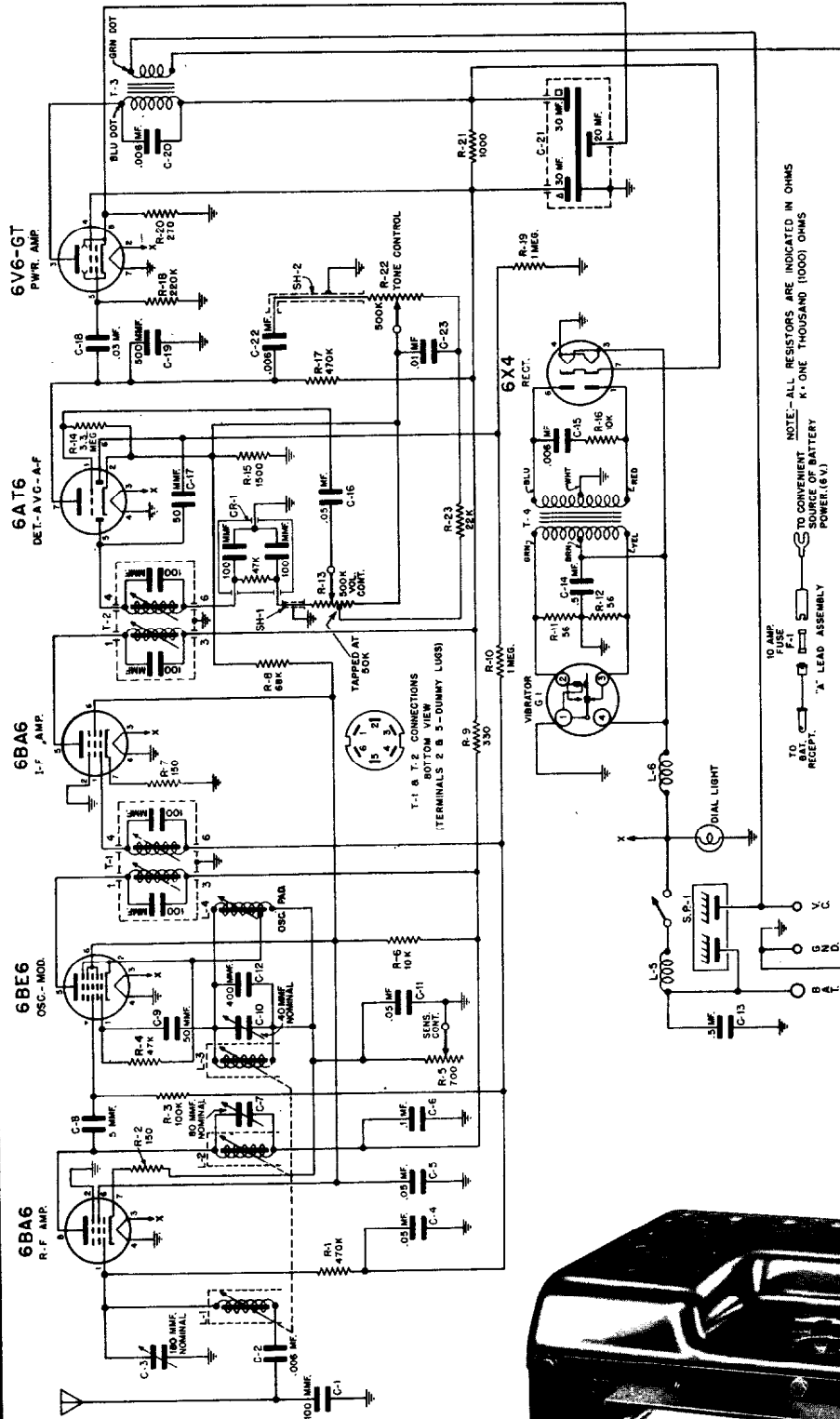

Motorola **AUTO** Radio

Motorola 8A Chassis is a 6-tube (including rectifier) automotive superheterodyne receiver. This chassis is universal and is used in Motorola Models FD8, CT8, NH8, OE2, SR8, SR6, BK8, BK8X, PC2, PC8, KR8, HN8, 8FDT, 8GNT, etc. An external speaker is used with these receivers.

TUNING RANGE - 535 to 1600 Kc IF FREQUENCY - 455 Kc

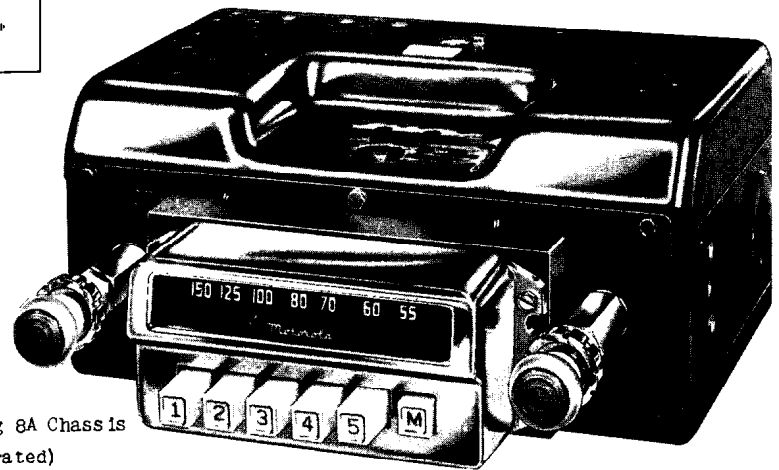

Typical Auto Receiver Using 8A Chassis (Model CT8 Illustrated)

Motorola HOME Radio

MODELS 58A11 & 58A12

CHASSIS HS-158

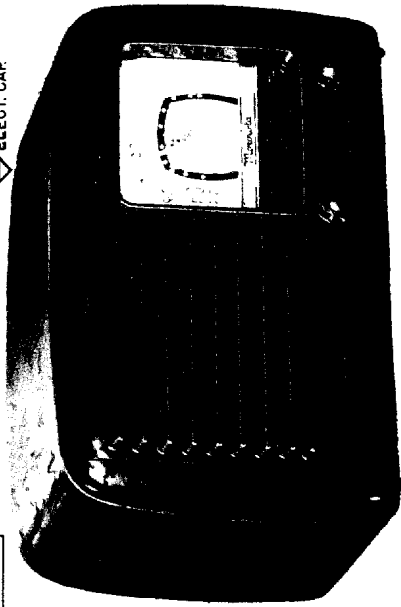
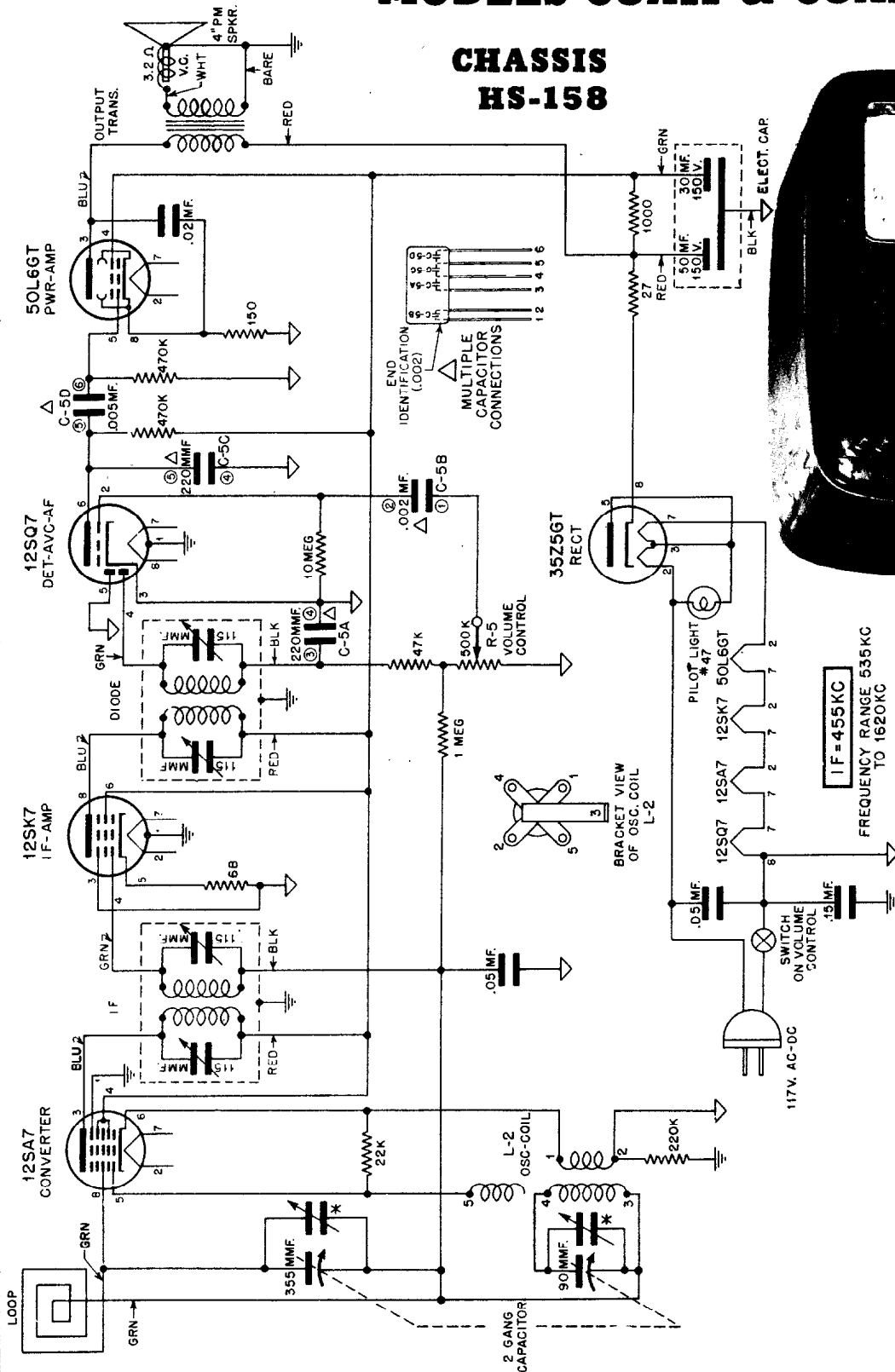

- NOTES**
- ⊖ = GROUND TO COMMON NEGATIVE.
 - ⊕ = GROUND TO CHASSIS.
 - * = TRIMMER ON GANG.
 - K = ONE THOUSAND (1000) OHMS.
 - Δ = MULTIPLE CAPACITOR.

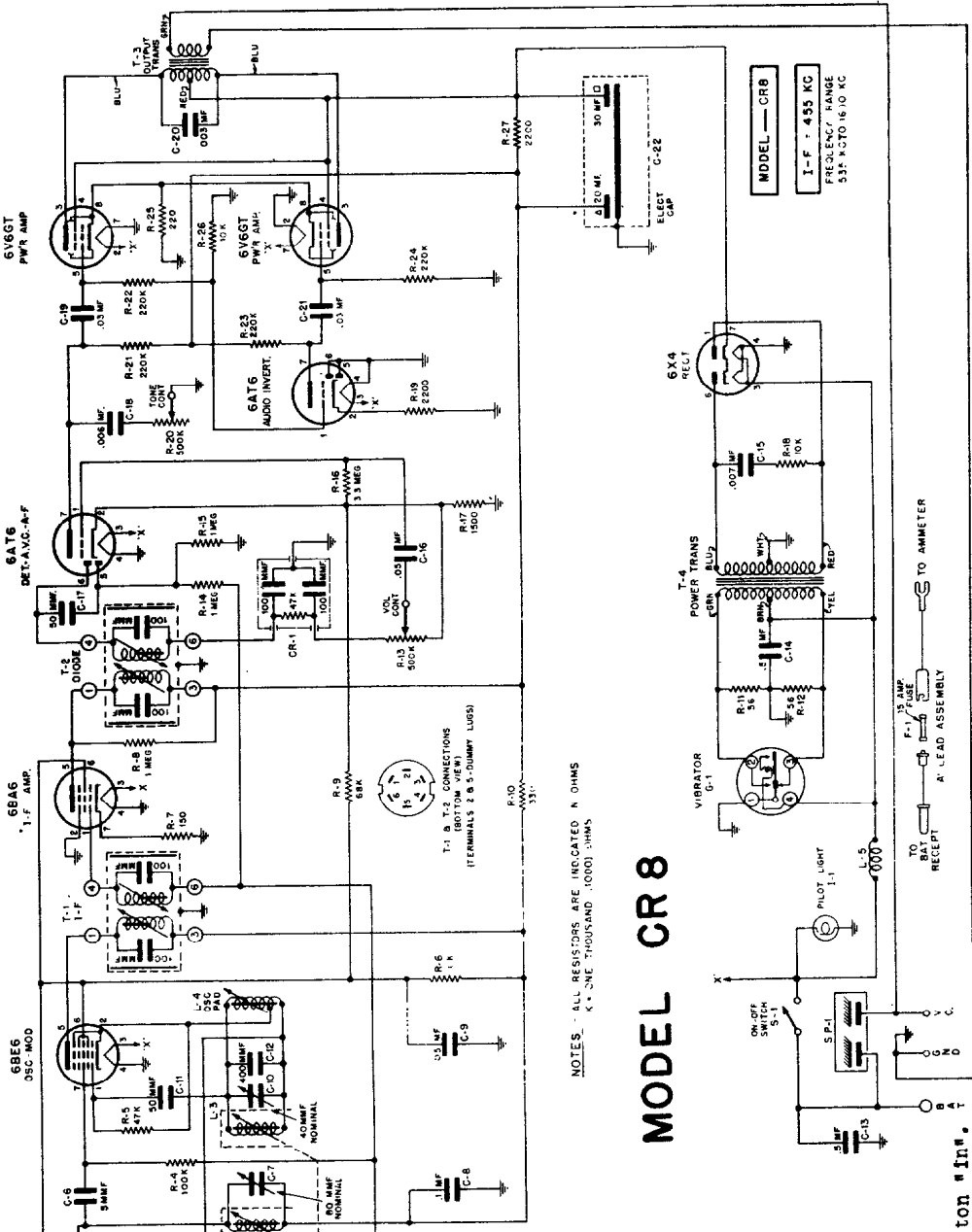

MODEL CR8

NOTES - ALL RESISTORS ARE INDICATED IN OHMS
 K = ONE THOUSAND .0000 = OHMS

Motorola AUTO Radio

Motorola Model CR8 is an 8-tube (including rectifier) automotive superheterodyne receiver using an external speaker.
 This receiver is specifically designed for installation in 1948 Plymouth, Dodge, DeSoto & Chrysler cars. It will also accommodate 1940, 1941, 1942, 1946 & 1947 Plymouth, Dodge, DeSoto & Chrysler cars.

TO SET THE PUSH BUTTONS

1. Turn radio on by pushing the top button "In". Allow radio to warm up for a few minutes.
2. Push the number "1" button in as far as it will go and HOLD IT THAT WAY.
3. With the tuning knob, tune in the station you desire to set up. The pointer will indicate the frequency of the station. Tune carefully until you are exactly on the station; tuning to either side of it will result in poor tone quality. Release button and knob after tuning in station.
4. Follow above steps 2 and 3 for the remaining four buttons.

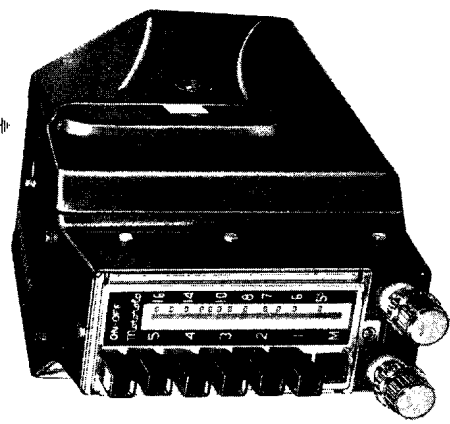

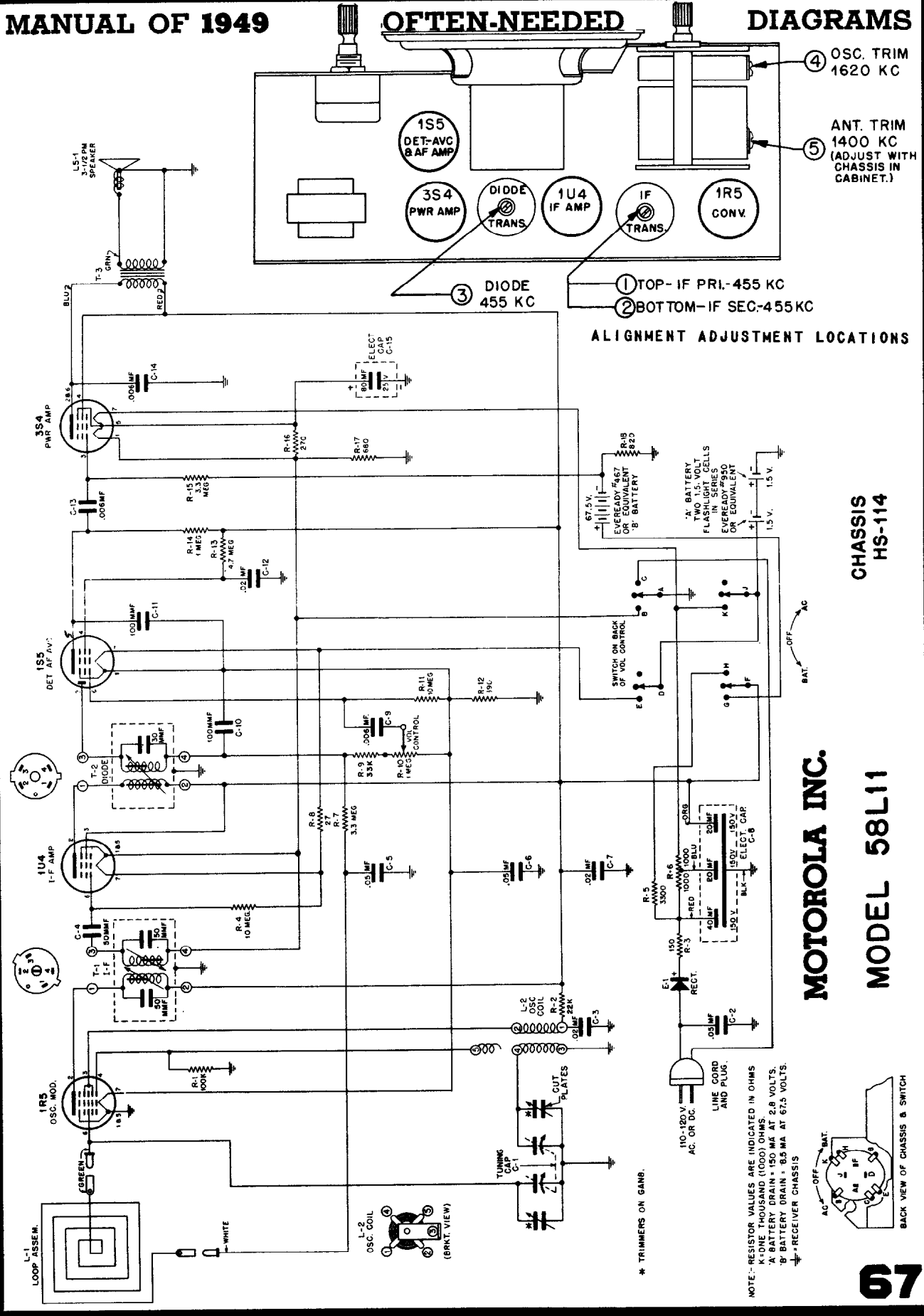

NOTE:—RESISTOR VALUES ARE INDICATED IN OHMS
 K—ONE THOUSAND (1000) OHMS.
 *A BATTERY DRAIN - 150 MA AT 2.8 VOLTS.
 *B BATTERY DRAIN - 8.5 MA AT 67.5 VOLTS.
 *—RECEIVER CHASSIS

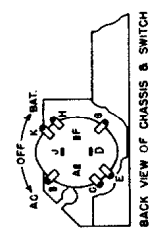

MOST-OFTEN-NEEDED RADIO DIAGRAMS

SCHEMATIC DIAGRAM
LEAR SUPERHETERODYNE MODEL 661
BOTTOM VIEWS OF ALL SOCKET CONNECTIONS

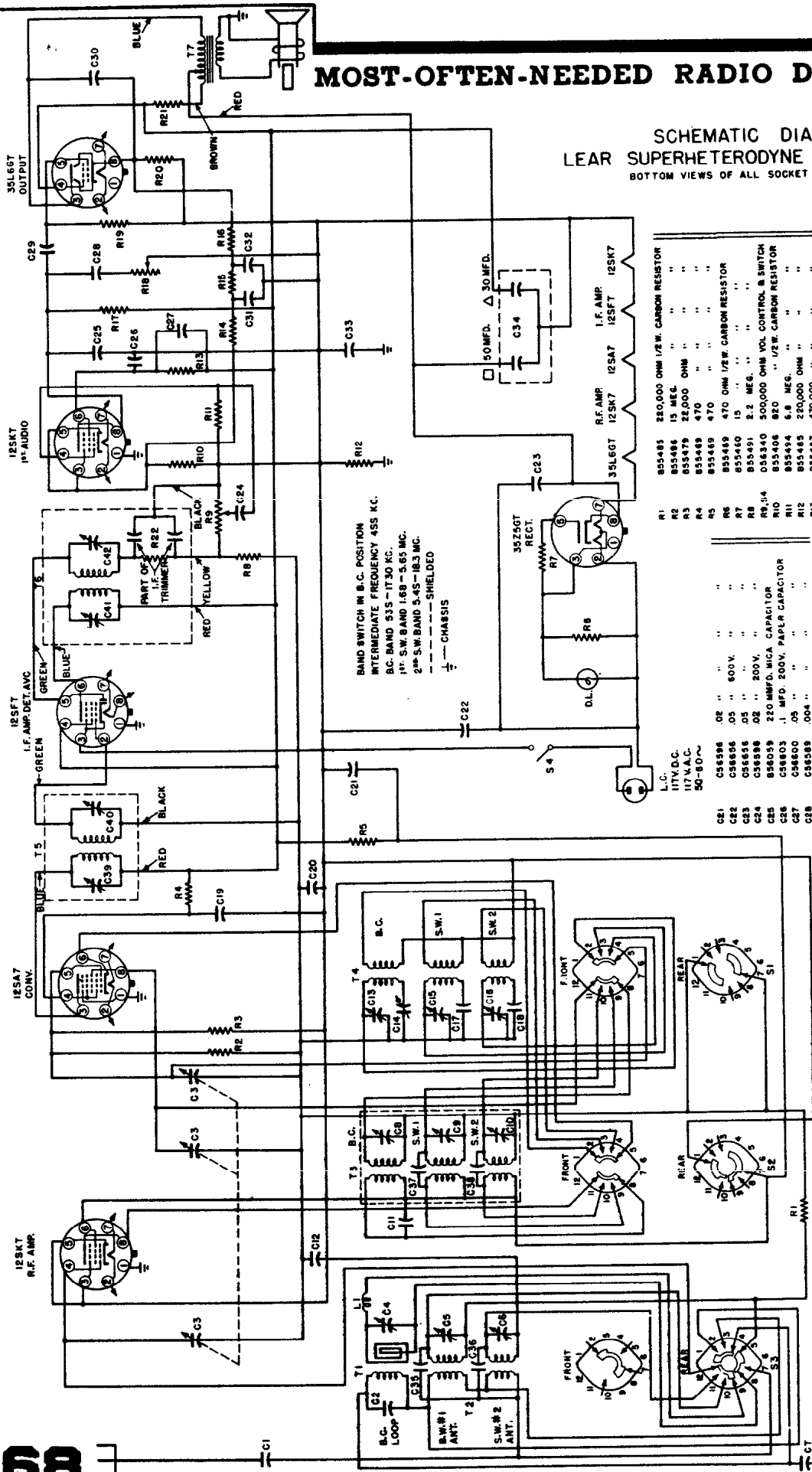

PART NO.	DESCRIPTION
R1	220,000 OHM 1/2W. CARBON RESISTOR
R2	15 MEG.
R3	22,000 OHM
R4	470 "
R5	470 "
R6	470 OHM 1/2W. CARBON RESISTOR
R7	15 "
R8	2 MEG. "
R9	500,000 OHM VOL. CONTROL & SWITCH
R10	820 "
R11	500,000 OHM 1/2W. CARBON RESISTOR
R12	220,000 OHM "
R13	470,000 OHM "
R14	2700 "
R15	4700 "
R16	853476 6000 "
R17	853483 100,000 "
R18	853493 500,000 " TONE CONTROL
R19	853487 470,000 " 1/2W. CARBON RESISTOR
REC	853466 150 "
R21	853494 1800 " 1/2W. "
R22	47,000 " "
L1	853383 LOADING COIL
L2	852648 BAND SWITCH ASSEMBLY
DL	470818 DIAL LIGHT, TYPE 47
L.G.	A83091 LINE CORD

PART NO.	DESCRIPTION
C21	50-80~ L.C.
C22	117V.D.C.
C23	35ZAGT 30 MFD. RECT.
C24	220 MMFD. MICA CAPACITOR
C25	.1 MFD. 200V. PAPER CAPACITOR
C26	.05 " " "
C27	.004 " " "
C28	OG-4 MFD. 200V. PAPER CAPACITOR
C29	.01 " " "
C30	400V. " " "
C31	200V. " " "
C32	400V. " " "
C33	30-50 MFD. 150V. ELECTROLYTIC
C34	3 MMFD. FIXED CAPACITOR
C35	3 " " "
C36	452874 3 " " "
C37	452874 3 " " "
C38	452874 3 " " "
C39	NO. 1 I.F. TRIMMERS (PART OF AS21)
C40	NO. 2 " " " "
C41, C42	" " " " "

PART NO.	DESCRIPTION
G56595	.001 MFD. 200V. PAPER CAPACITOR
A52644	B.C. RF TRIMMER ASSEMBLY
G7	" " "
G8	" " "
G9	" " "
G10	" " "
G11	47 MMFD. MICA CAPACITOR
G12	.02 MFD. 200V. PAPER CAPACITOR
G13	B.C. OSC. TRIMMER ASSEMBLY
A52665	" " "
G14	PADDER
G15	" " "
A52684	S.W. #1 TRIMMER
G16	" " "
A50235	1250 MMFD. MICA CAPACITOR, TOL. ± 5%
G17	B.C. ANT. TRIMMER ASSEMBLY
A52686	" " "
G18	" " "
G19	" " "
G20	A52684 S.W. #2 TRIMMER

PART NO.	DESCRIPTION
T1	B.G. LOOP ASSEMBLY
T2	S.W. BAND 182 ANT. COIL ASSEMBLY
T3	B.C. ANT. S.W. #1 R.F.
T4	B.C. ANT. S.W. #2 R.F.
T5	NO. 1 I.F. TRANSFORMER
T6	" " "
T7	OUTPUT
G1	220 MMFD. MICA CAPACITOR
G2	82 " " "
G3	3 GANG VARIABLE " WITH PULLEY
C4	B.C. ANT. TRIMMER ASSEMBLY
C5	" " "
C6	A52684 S.W. #1 TRIMMER
C7	" " "

MANUAL OF 1949 MOST-OFTEN-NEEDED RADIO DIAGRAMS

MOTOROLA INC.

MODELS 67X11, 67X12,
& 67X13

CHASSIS
HS-58

NOTE

- ⬇️ GROUND TO CHASSIS.
- ⬆️ TRIMMER ON GANG (TOP).
- ⬆️ TRIMMER ON GANG (BOTTOM, DO NOT ADJUST).
- ✖️ ALL RESISTORS ARE INDICATED IN OHMS
X = 1000 OHMS

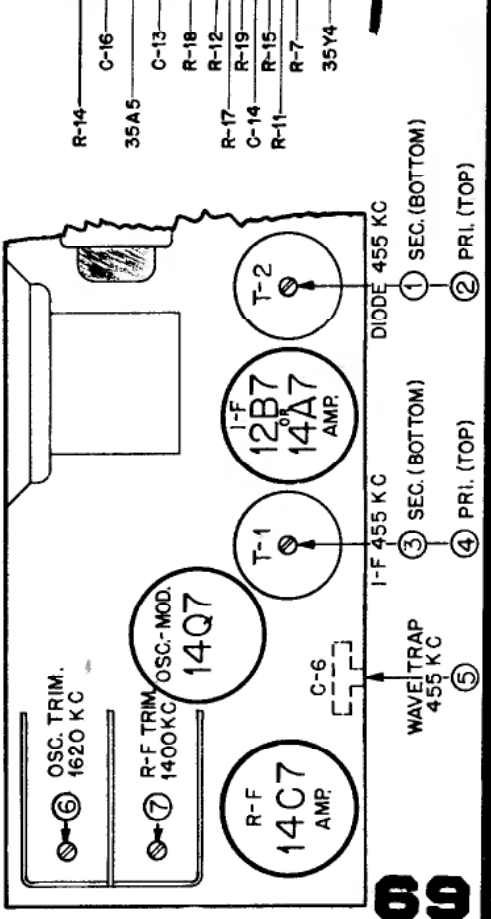
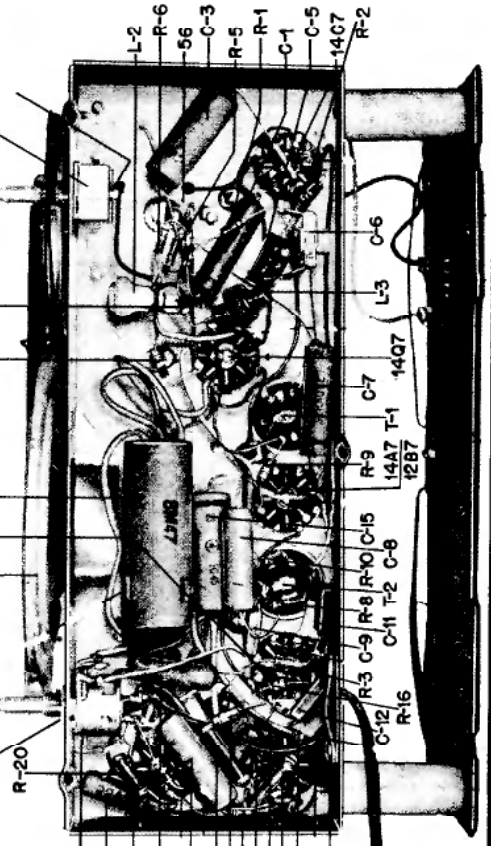
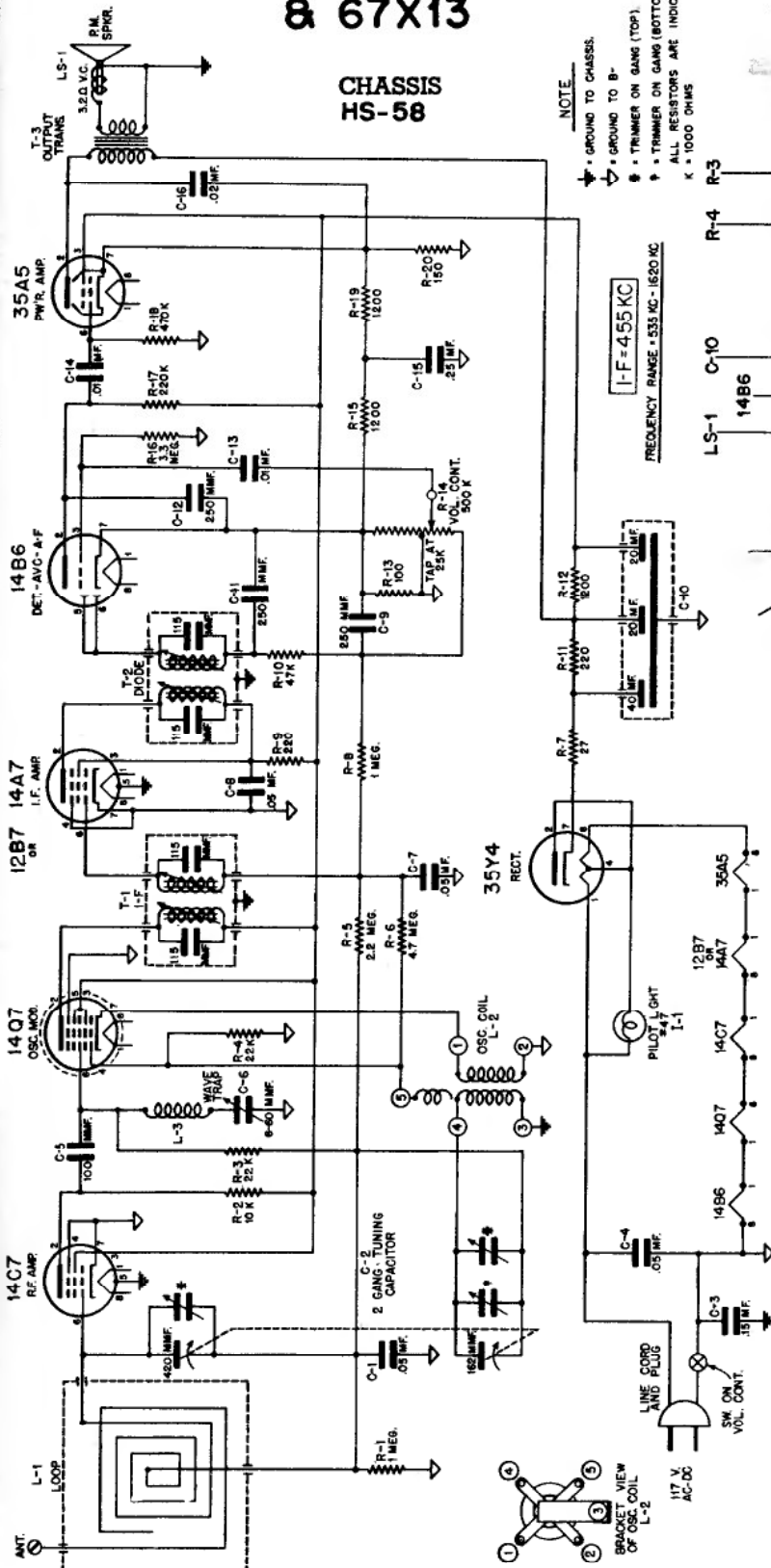

MANUAL OF 1949 MOST-OFTEN-NEEDED RADIO DIAGRAMS

Motorola HOME Radio

CHASSIS
HS-119

MODEL 68L11

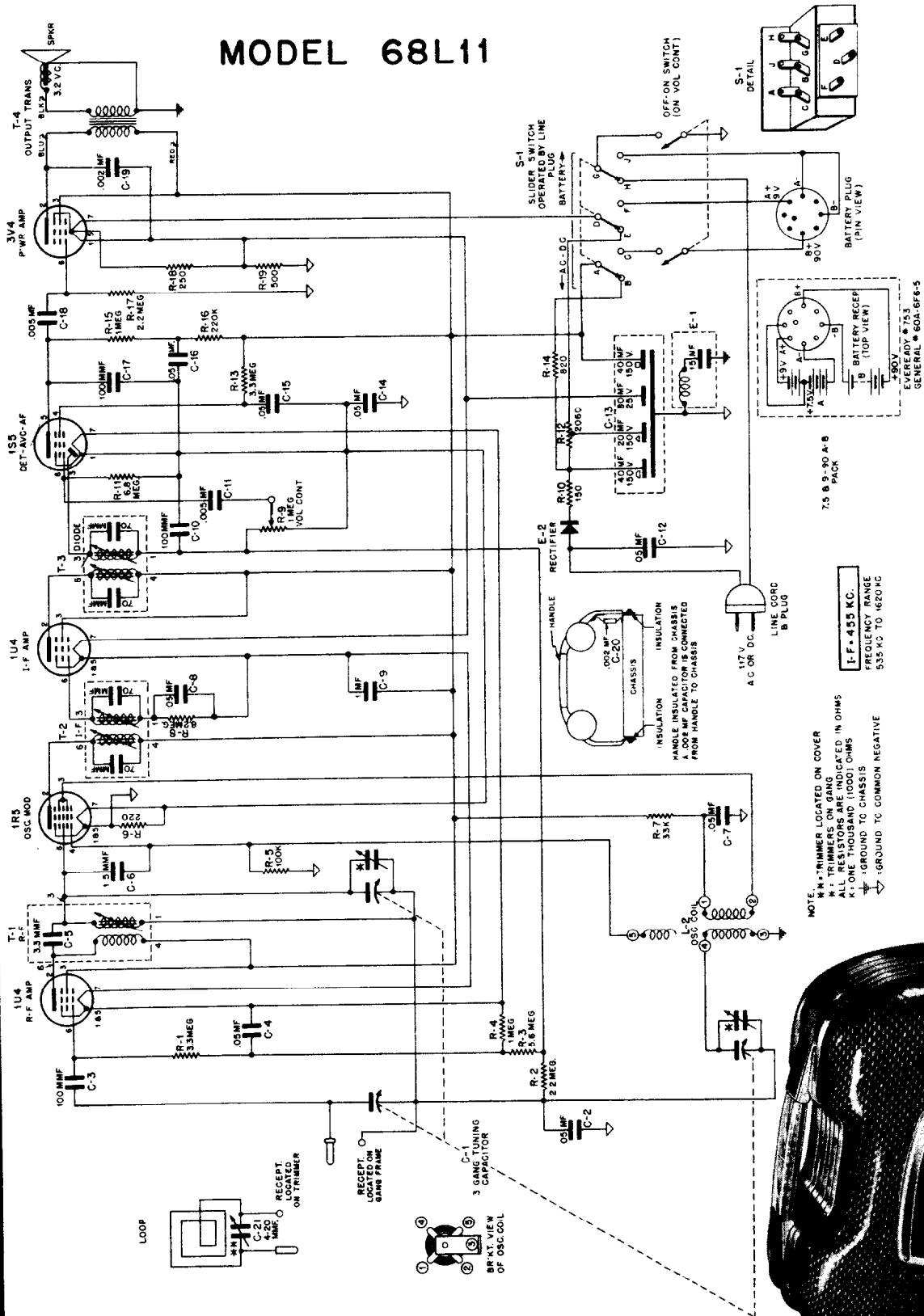

MOTOROLA INC.

NOTE:
 * - TRIMMERS LOCATED ON COVER
 † - TRIMMERS ON GANG
 ALL RESISTORS ARE INDICATED IN OHMS
 K - ONE THOUSAND (1000) OHMS
 † - GROUND TO CHASSIS
 ↗ - GROUND TO COMMON NEGATIVE
 F - F. 455 KC.
 FREQUENCY RANGE
 535 KC TO 1620 KC

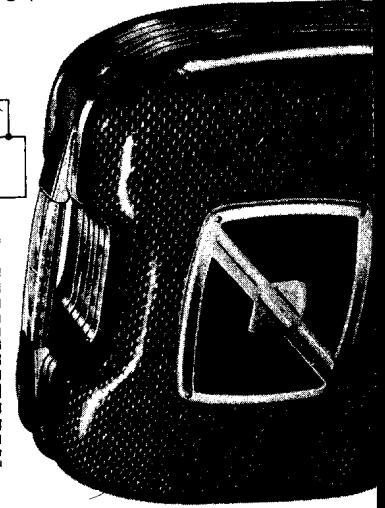

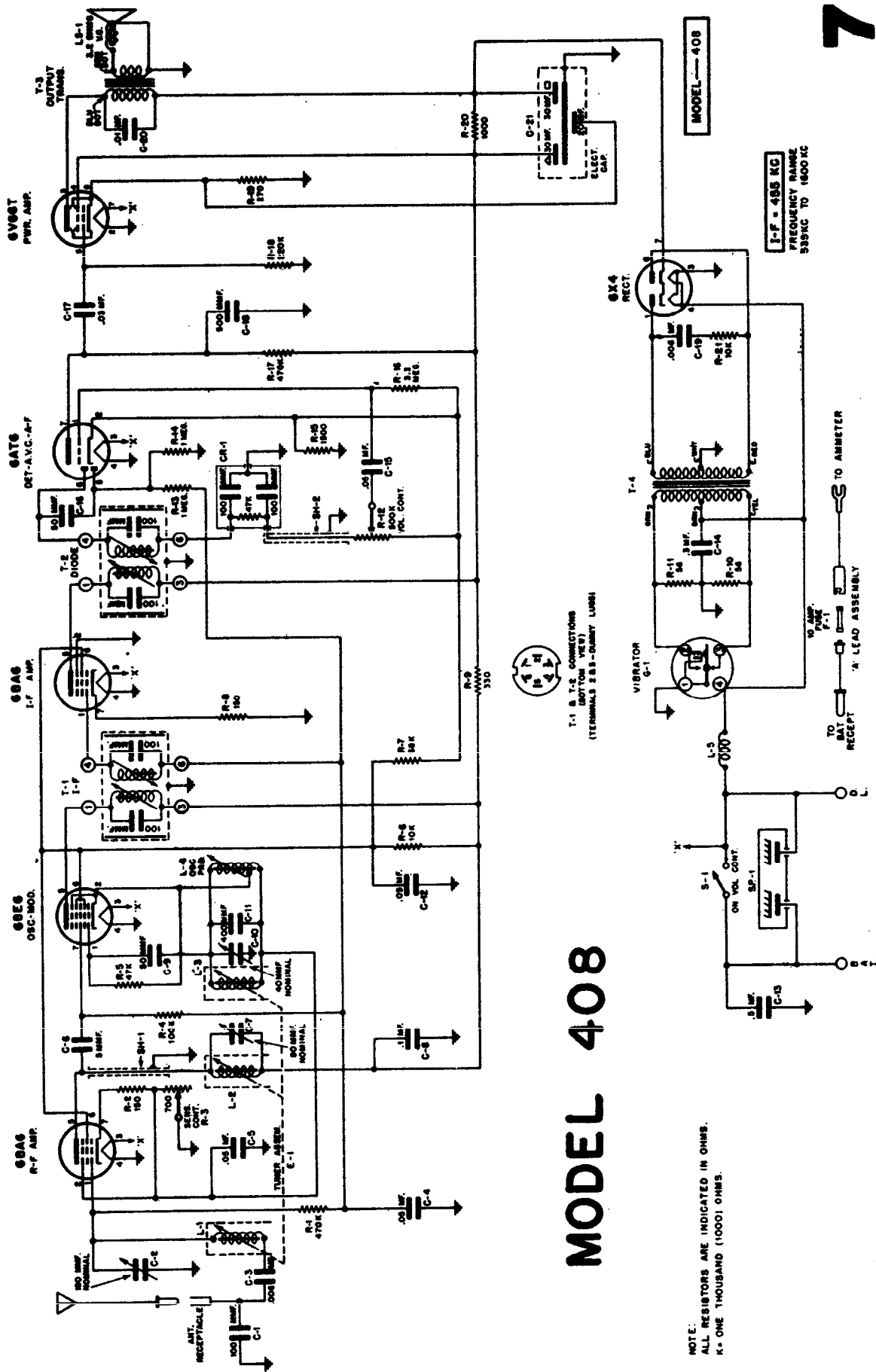

MODEL 408

NOTE:
ALL RESISTORS ARE INDICATED IN OHMS.
K = ONE THOUSAND (1000) OHMS.

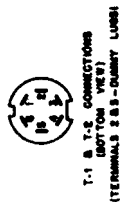

I-F = 485 KC
FREQUENCY RANGE
535Kc TO 1600 Kc

MODEL-408

MANUAL OF 1949 MOST-OFTEN-NEEDED RADIO DIAGRAMS

Motorola **AUTO Radio**

MODEL 708

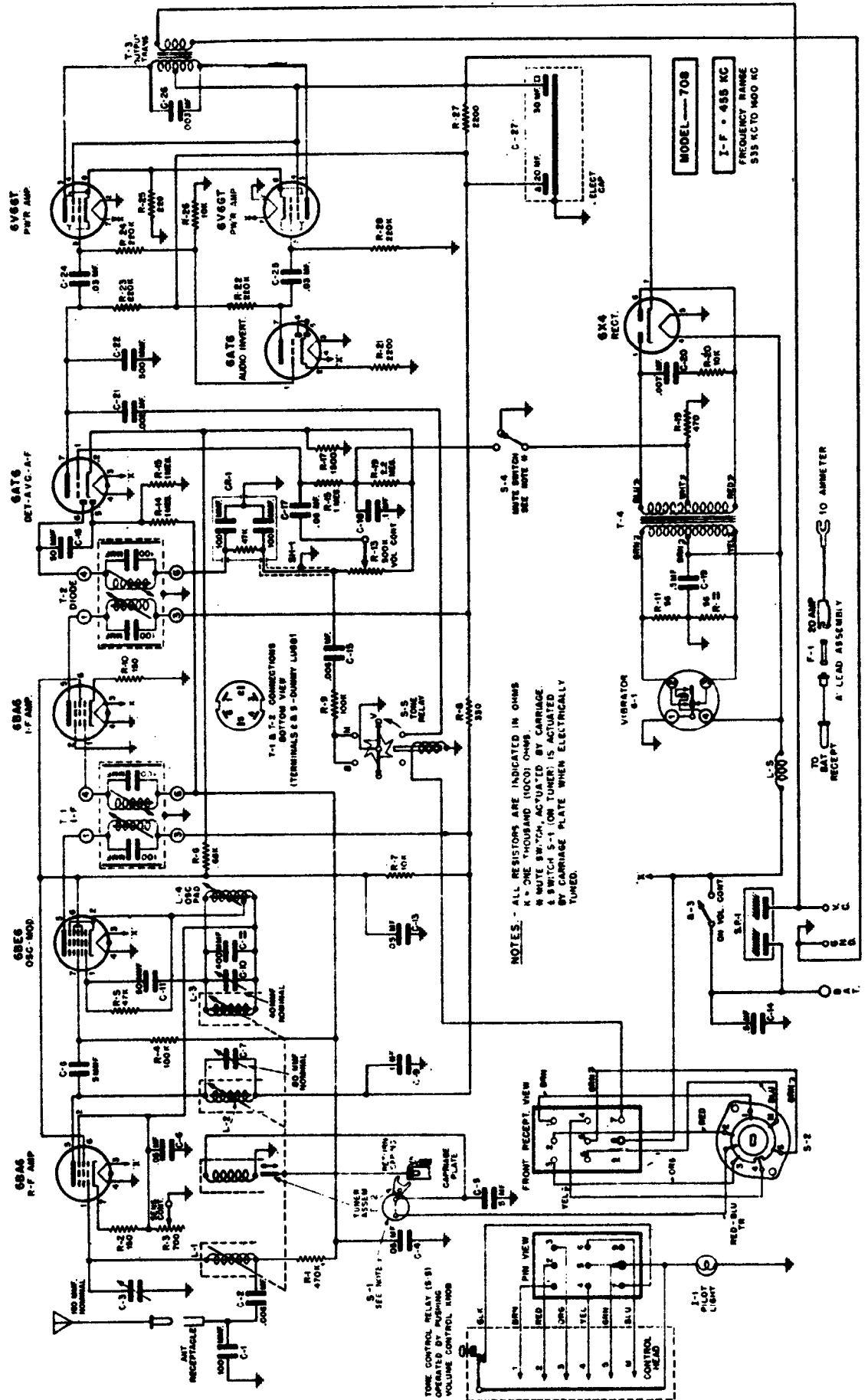

MANUAL OF 1949 MOST-OFTEN-NEEDED RADIO DIAGRAMS

ARVIN RADIOS, MODELS 152T AND 153T
CHASSIS RE-233, 5 TUBE AC-DC

NOBLITT - SPARKS INDUSTRIES, INC., COLUMBUS, IND.

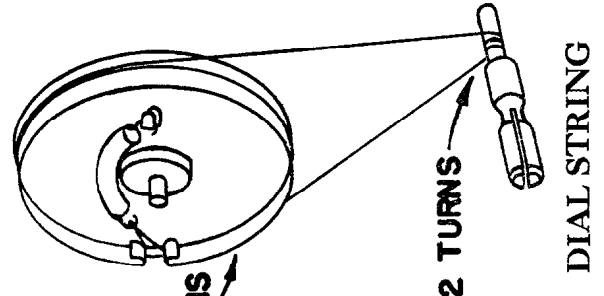
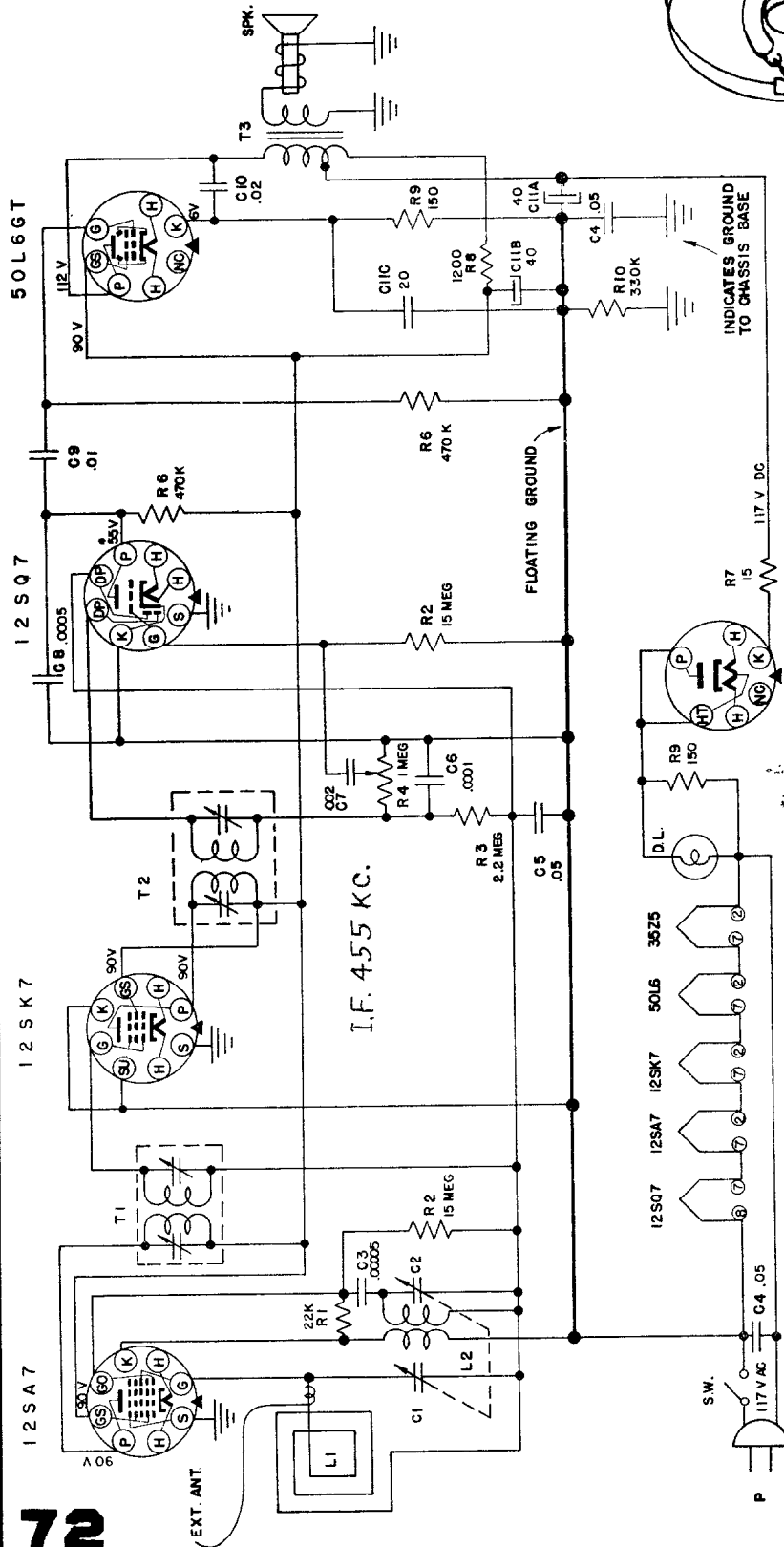

1 1/2 TURNS
LOCATION OF PARTS
UNDER CHASSIS

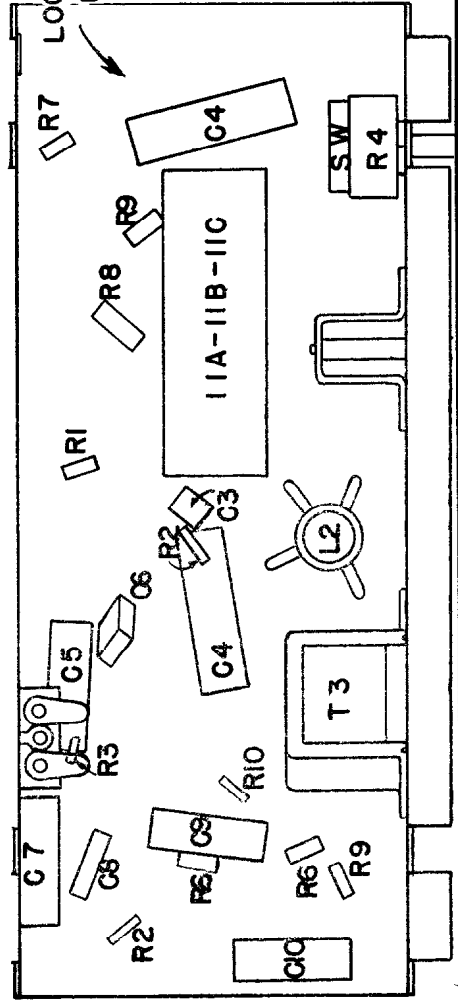
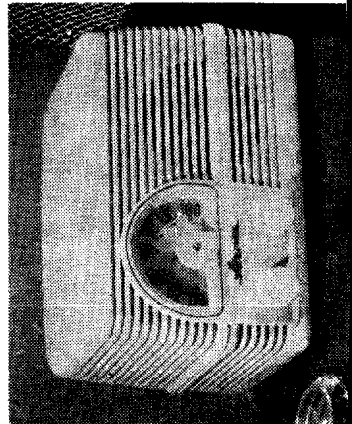

MANUAL OF 1949 MOST-OFTEN-NEEDED RADIO DIAGRAMS

ARVIN RADIOS, MODELS 241P, 244P & 2410P; CHASSIS-RE-244, RE-255, RE-256, RE-259 & RE-254
4 TUBE, AC-DC, BATTERY, PORTABLE

NOBLITT-SPARKS INDUSTRIES, Inc., COLUMBUS, INDIANA

Model 240P, Chassis RE-243
battery portable uses a
similar circuit.

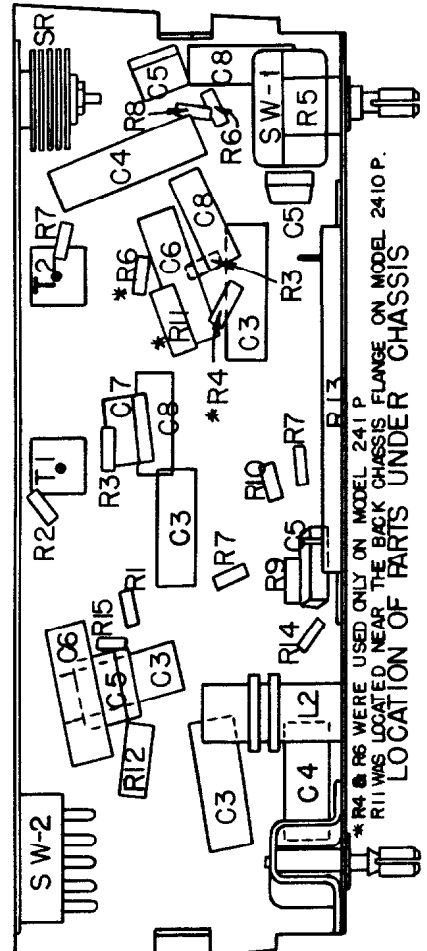
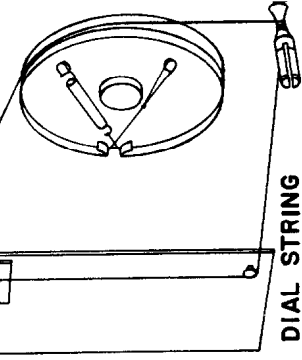
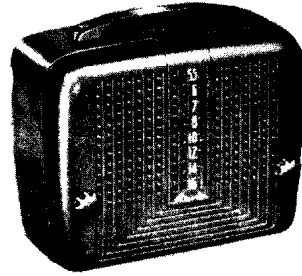
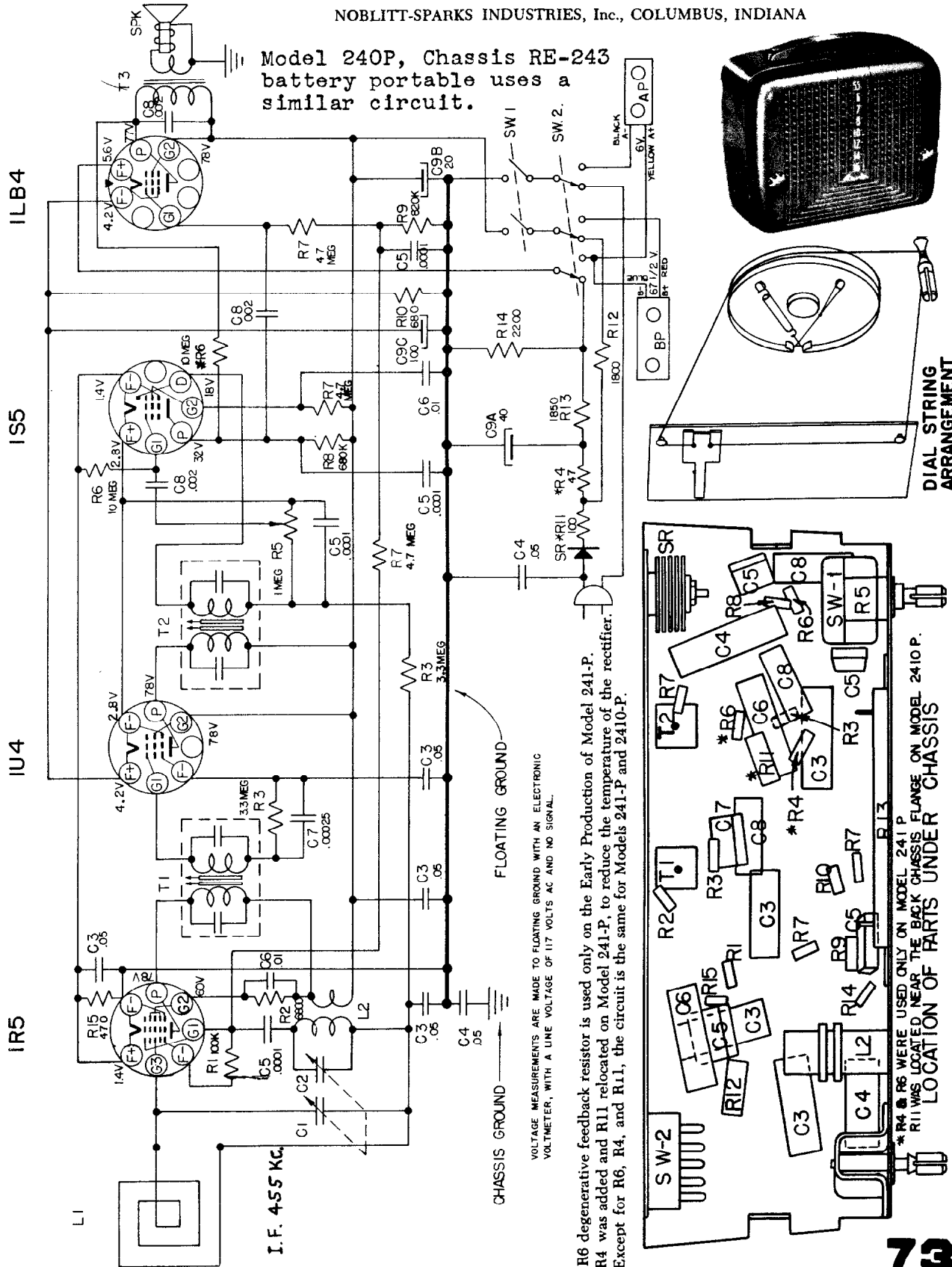

* R4 & R6 WERE USED ONLY ON MODEL 241 P
R11 WAS LOCATED NEAR THE BACK CHASSIS FLANGE ON MODEL 2410 P.
LOCATION OF PARTS UNDER CHASSIS

MANUAL OF 1949 MOST-OFTEN-NEEDED RADIO DIAGRAMS

ARVIN RADIOS — MODELS 280TFM & 281TFM CHASSIS RE — 253

8 TUBE AC — DC, AM — FM

MANUFACTURED BY NOBLITT-SPARKS INDUSTRIES, Inc., COLUMBUS, IND.

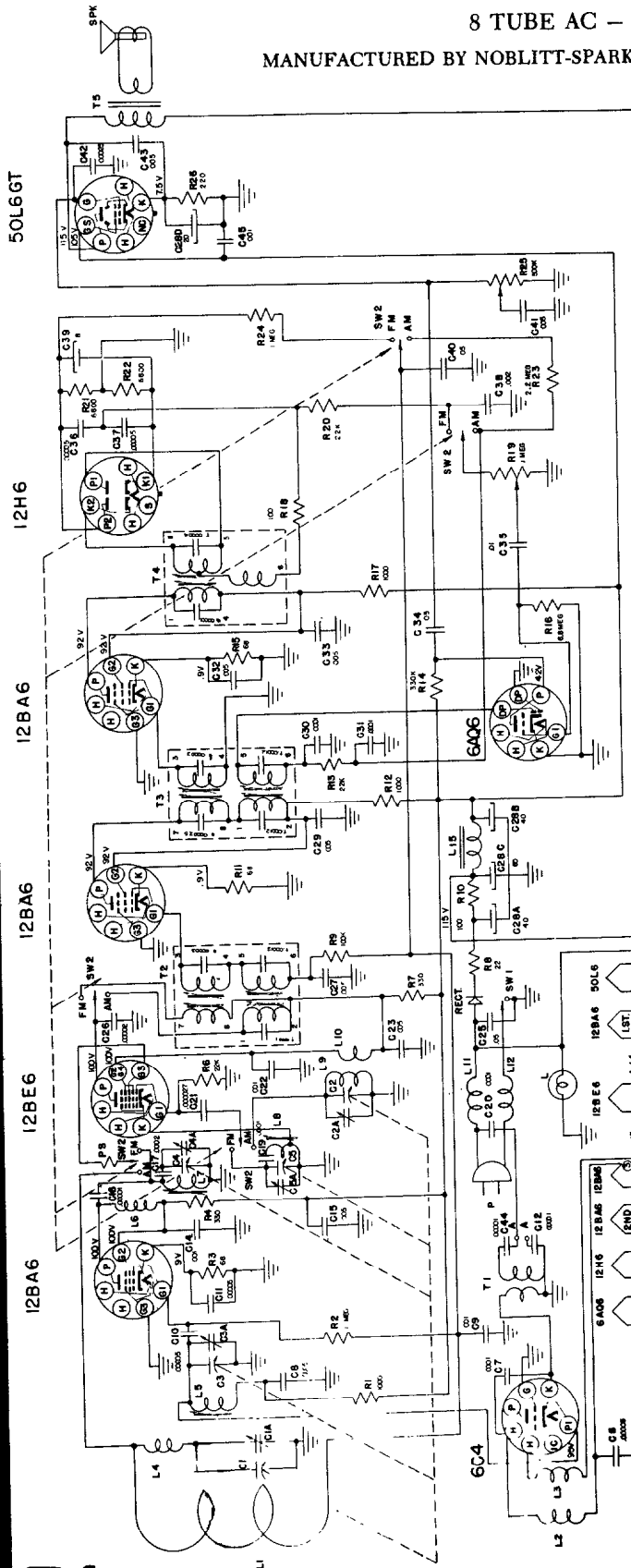

ALL VALUE MEASUREMENTS ARE MADE WITH AN ELECTRONIC VOLTMETER WITH A LINE VOLTAGE OF 117 V. AC WITH NO SIGNAL. ALL VOLTAGE INDICATED SHOULD BE POSITIVE.

* GRANGE BODY, 0.5 E.M.P.
† SILVER BRN. BODY 10%

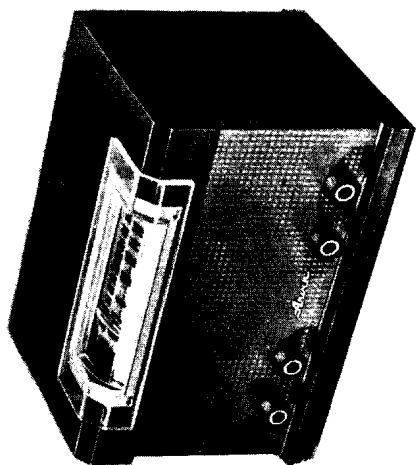

FREQUENCY RANGE

Broadcast Band	540-1600 KC
AM-IF	455 KC
FM Band	88-108 MC
FM-IF	10.7 MC

RED DOT ON FIRST I.F. TRANS., GREEN DOT ON SECOND I.F. TRANS.
LUGS ARE COUNTED IN A CLOCKWISE DIRECTION, BEGINNING AT THIS DOT.

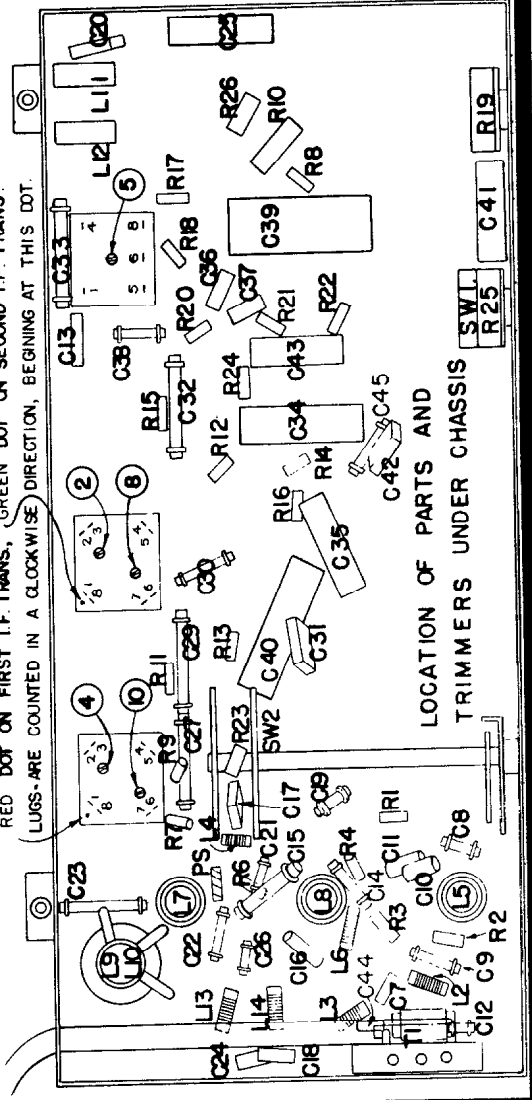

LOCATION OF PARTS AND TRIMMERS UNDER CHASSIS

MANUAL OF 1949 MOST-OFTEN-NEEDED RADIO DIAGRAMS

ARVIN RADIO - MODEL 250P CHASSIS RE-248

5 TUBE AC - DC, BATTERY, PORTABLE

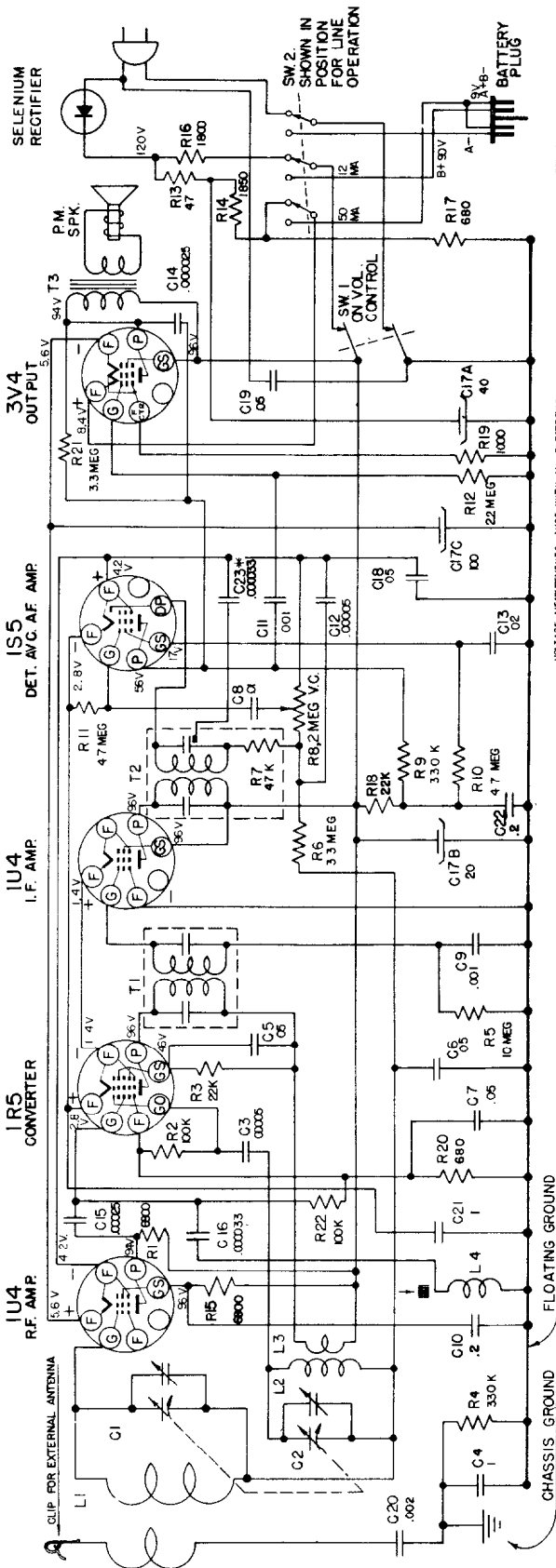

VOLTAGE MEASUREMENTS MADE WITH AN ELECTRONIC VOLTMETER WITH UTILITY AC LINE VOLTAGE AND NO SIGNAL

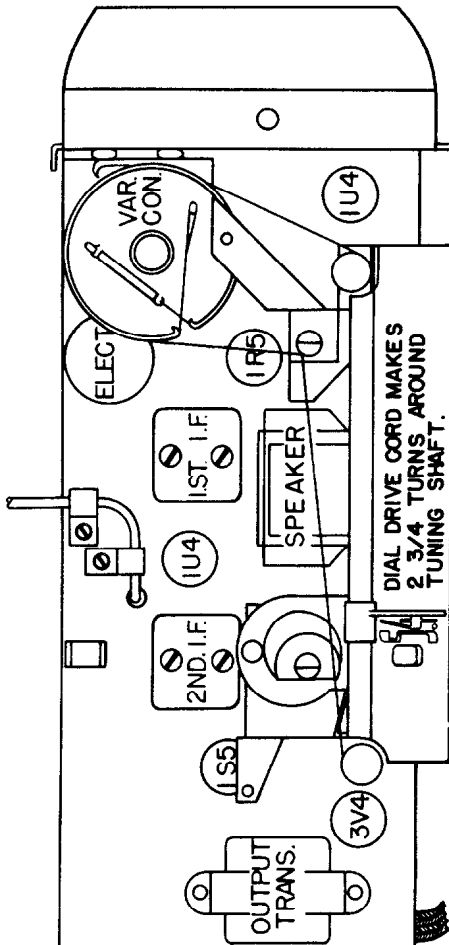
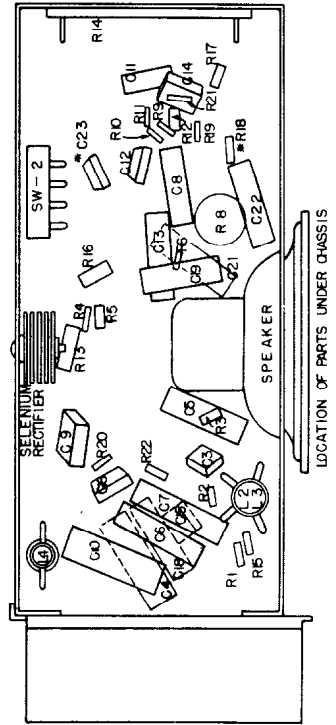
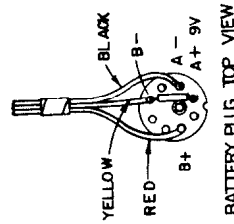
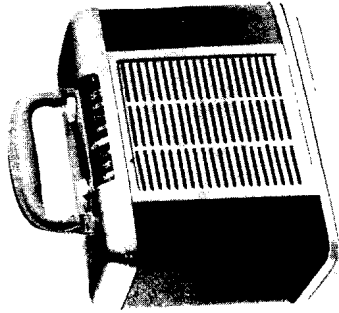

TUBE LAYOUT

On battery operation, the B+ voltage measured to floating ground should be the sum of the A & B battery voltages or approximately 99 Volts with new batteries.

FREQUENCY RANGE
Broadcast ----- 540-1600 kc
IF ----- 455 kc

MANUAL OF 1949 MOST-OFTEN-NEEDED RADIO DIAGRAMS

ARVIN RADIOS, MODELS 160T AND 161T
CHASSIS RE-232, 6 TUBE AC-DC

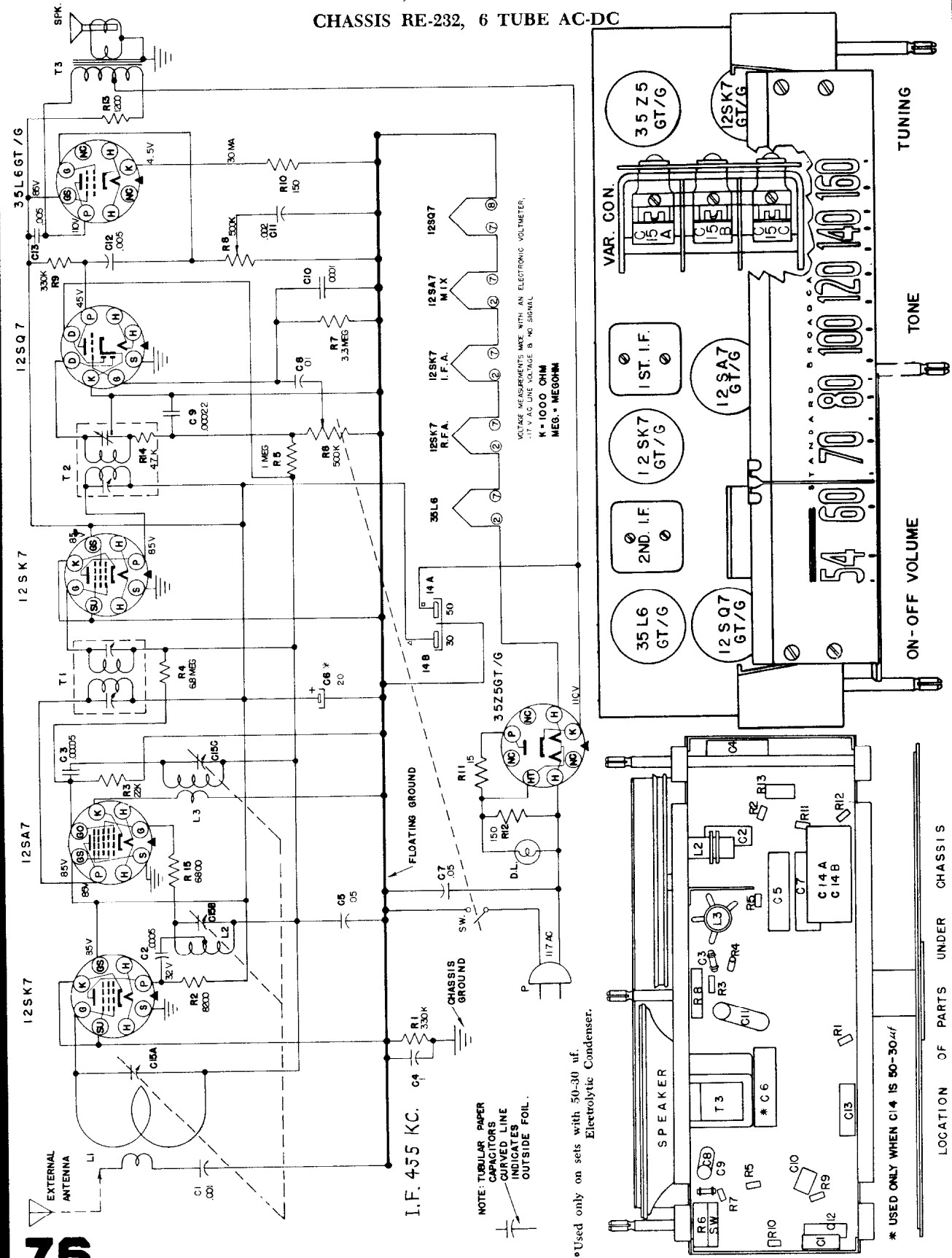

MANUAL OF 1949 MOST-OFTEN-NEEDED RADIO DIAGRAMS

ARVIN RADIOS – MODELS 547 AND 547A

CHASSIS RE – 242; 5 TUBE AC – DC

ALIGNMENT PROCEDURE

PRELIMINARY:

Output meter connection Across loudspeaker voice coil
 Output meter reading to indicate 200 milliwatts (standard output) 0.8 volts
 Dummy antenna to be used in series with generator output See chart below
 Connection of generator output lead See chart below
 Connection of generator ground lead Floating ground
 Generator modulation 30% 400 cycles
 Position of Volume Control Fully clockwise
 Position of dial pointer with variable fully closed Horizontal
 Place the set loop in the same position with respect to the rear of the chassis, and the same distance from the chassis, as it would be with the set mounted in the cabinet.

Position of Variable	Frequency of Generator	Dummy Antenna	Generator Output Connection	Trimmers Adjusted In Order Shown For Maximum Output	Function of Trimmer
Open	455	.05 mfd.	12SA7 Grid (Stator of C-1)	Top of 2nd & 1st IF trans. T2 & T1	IF
1400	1400		*Test Loop	C2; C1, Trimmers on Variable Condenser	Osc. Ant.
600	600		*Test Loop	Check Point (If weak, adjust variable plates for maximum output.)	

*Standard Hazeltine Test Loop Model 1150 or 3 turns of wire about 6" in diameter, placed about one foot from the set loop.

The alignment procedure should be repeated in the original order for greatest accuracy. Always keep the output from the signal generator at its lowest possible value to make the AVC action of the receiver ineffective.

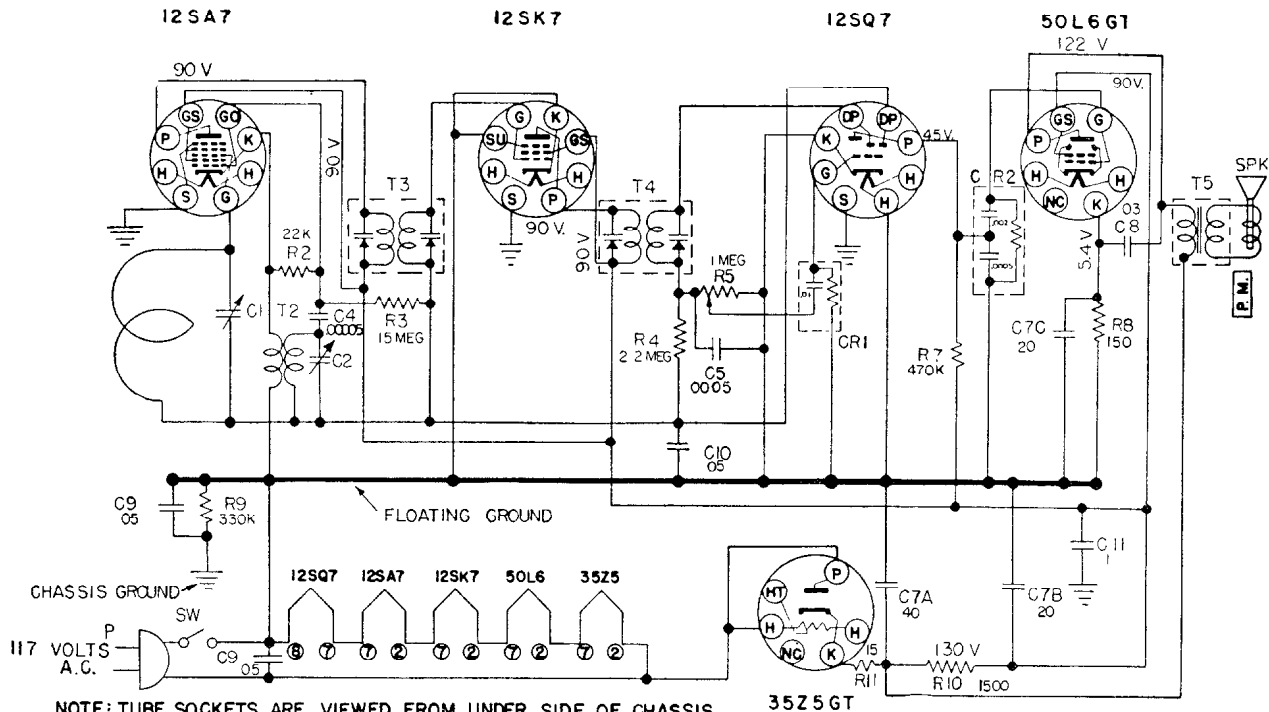
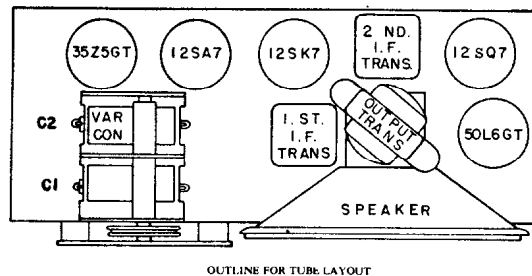
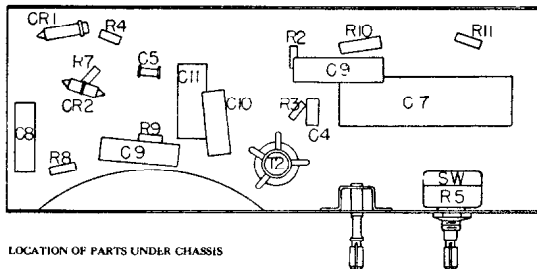

NOTE: TUBE SOCKETS ARE VIEWED FROM UNDER SIDE OF CHASSIS. VOLTAGE READINGS SHOWN AT SOCKET PRONGS ARE TO FLOATING GROUND AND ARE TAKEN WITH NO SIGNAL. A.C. LINE VOLTAGE AT 117 VOLTS. WHERE NO READING IS GIVEN, THE VOLTAGE IS ZERO OR TOO LOW TO READ.

MANUAL OF 1949 MOST-OFTEN-NEEDED RADIO DIAGRAMS

ARVIN RADIO - MODELS 242T & 243T

CHASSIS RE-251 - 4 TUBE AC - DC

MANUFACTURED BY NOBLITT-SPARKS INDUSTRIES, Inc., COLUMBUS, IND.

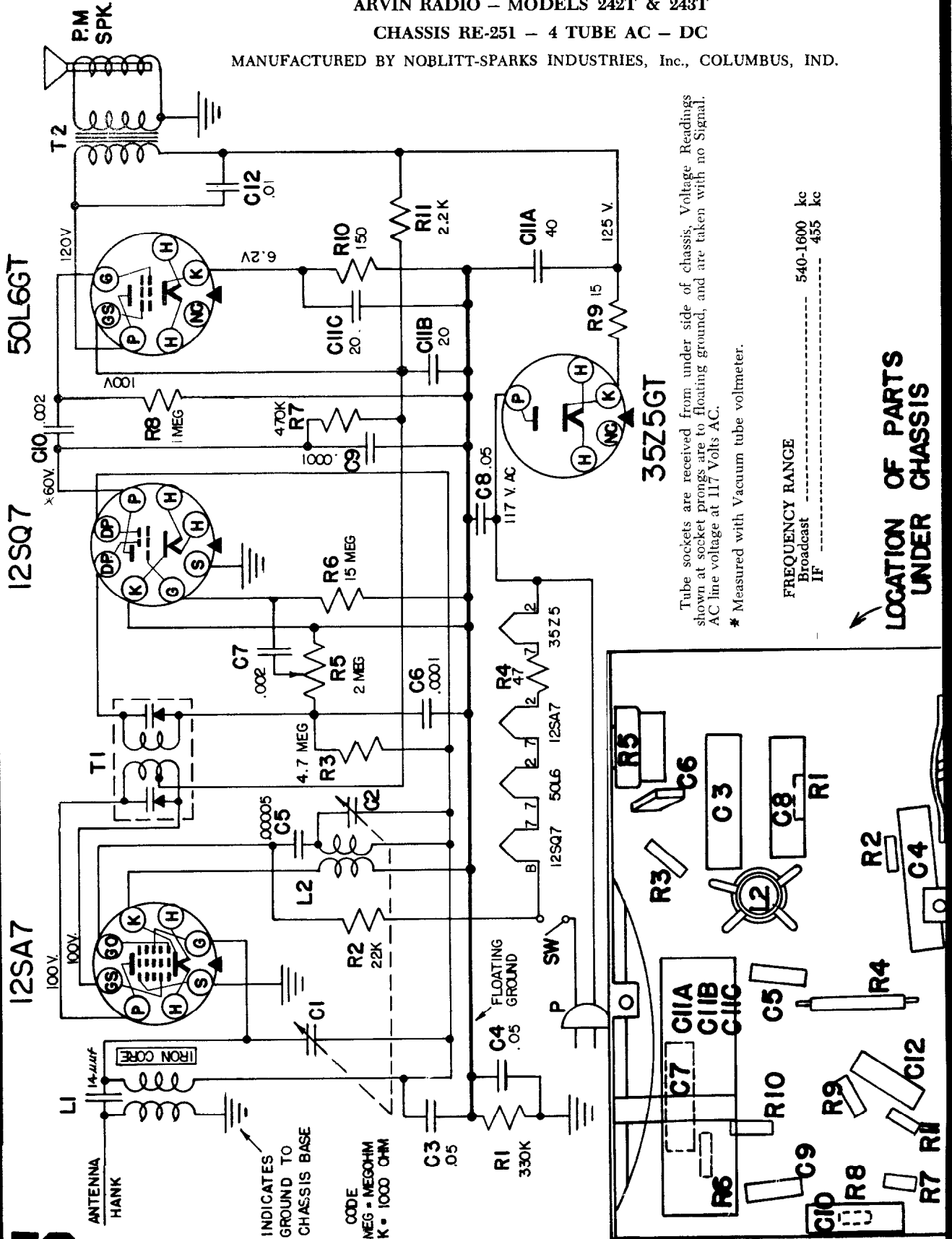

Tube sockets are received from under side of chassis. Voltage Readings shown at socket prongs are to floating ground, and are taken with no signal. AC line voltage at 117 Volts AC.

* Measured with Vacuum tube voltmeter.

FREQUENCY RANGE
 Broadcast ----- 540-1600 kc
 IF ----- 455 kc

LOCATION OF PARTS UNDER CHASSIS

1949 MOST-OFTEN-NEEDED RADIO DIAGRAMS

OLYMPIC TRU-BASE RADIO

Models 7-622 and 7-638

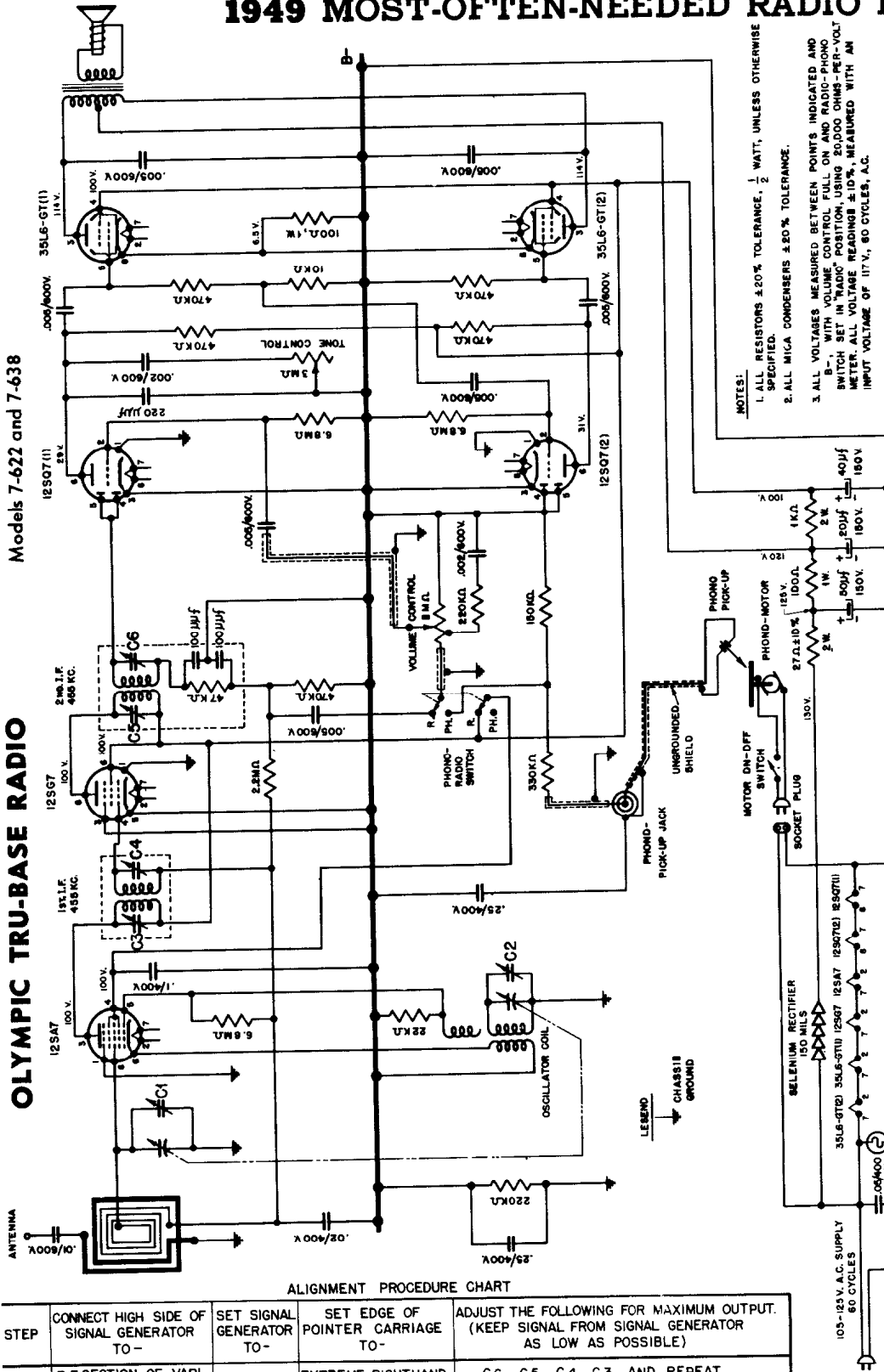

ALIGNMENT PROCEDURE CHART

STEP	CONNECT HIGH SIDE OF SIGNAL GENERATOR TO -	SET SIGNAL GENERATOR TO -	SET EDGE OF POINTER CARRIAGE TO -	ADJUST THE FOLLOWING FOR MAXIMUM OUTPUT. (KEEP SIGNAL FROM SIGNAL GENERATOR AS LOW AS POSSIBLE)
1	R.F. SECTION OF VARIABLE CONDENSER IN SERIES WITH A .1 MFD. 400 VOLT CONDENSER.	455 KC.	EXTREME RIGHTHAND POSITION (CONDENSER PLATES FULLY OPEN)	C6, C5, C4, C3 AND REPEAT IN SAME ORDER. (1st AND 2nd I.F. TRANSFORMERS)
2	USE RADIATED SIGNAL (CONNECT BOTH SIDES OF SIGNAL GENERATOR TO RADIATION LOOP)	1400 KC.	1400 KC. CALIBRATION POINT.	C2 AND C1 OSCILLATOR AND R.F. TRIMMERS
3		600 KC.	RESONANCE (APPROXIMATELY 600KC. CALIBRATION POINT.)	CHECK THAT EDGE OF POINTER CARRIAGE (AT RESONANCE) COINCIDES WITH 600 KC. CALIBRATION POINT.

- NOTES:
1. ALL RESISTORS ±20% TOLERANCE, 1/2 WATT, UNLESS OTHERWISE SPECIFIED.
 2. ALL MICA CONDENSERS ±50% TOLERANCE.
 3. ALL VOLTAGES MEASURED BETWEEN POINTS INDICATED AND SWITCH SET IN "RADIO" POSITION, USING RESISTOR-VOLTMETER. ALL VOLTAGE READINGS ±10%, MEASURED WITH AN INPUT VOLTAGE OF 117 V, 60 CYCLES, A.C.

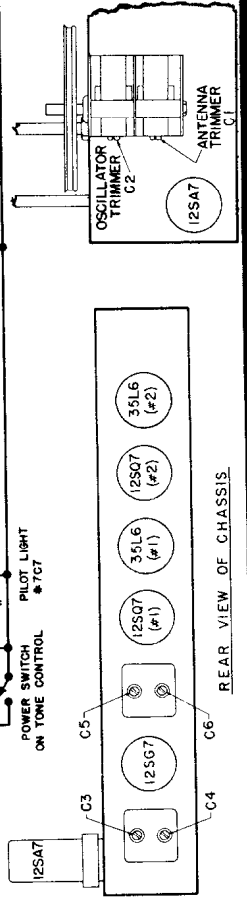

OLYMPIC RADIO & TELEVISION

Models 7-622 and 7-638

MANUAL OF 1949 MOST-OFTEN-NEEDED RADIO DIAGRAMS

Packard-Bell

MODEL 771 AND 771X

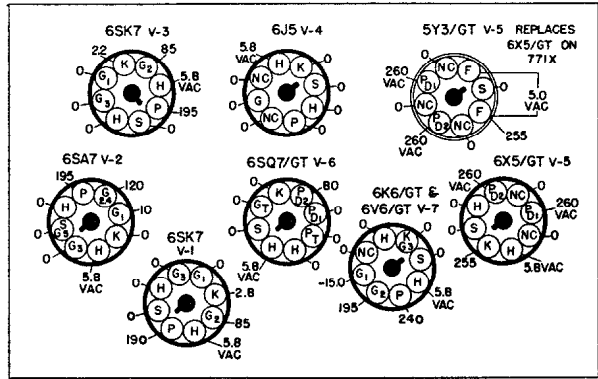

All D.C. voltages measured with a vacuum tube voltmeter from socket contacts to chassis.—A.C. voltages measured with a 1000 ohms per volt A.C. meter from socket contacts to chassis.

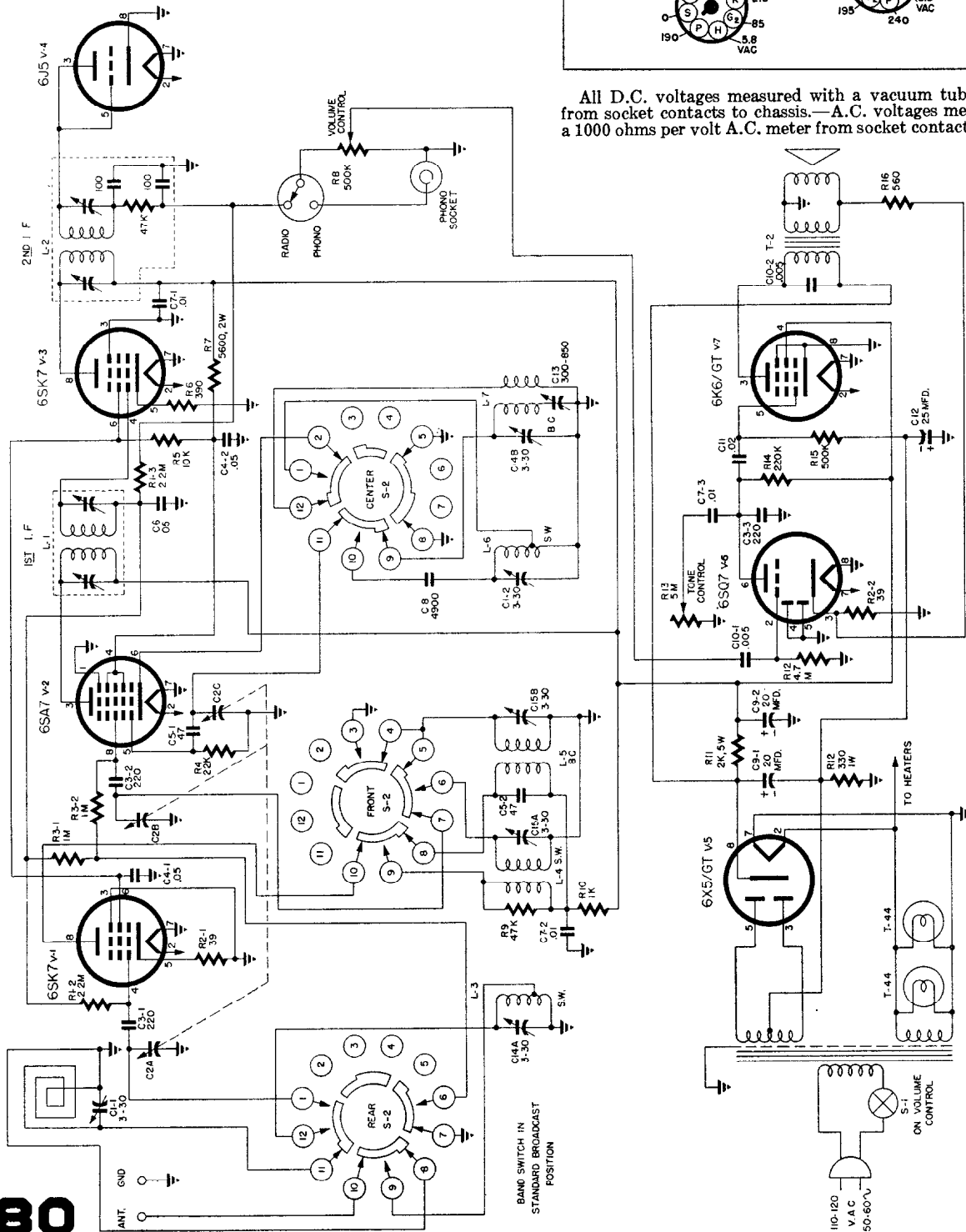

Intermediate Frequency:
455 KC

Tuning Frequency Range:
Standard Broadcast 540 to 1620 KC
Short Wave 6 to 18 MC

MANUAL OF 1949 MOST-OFTEN-NEEDED RADIO DIAGRAMS

Philco diagram and service information on this page and on the Philco pages following are reproduced through the courtesy of the Philco Corporation from material supplied by the Philco Corporation.

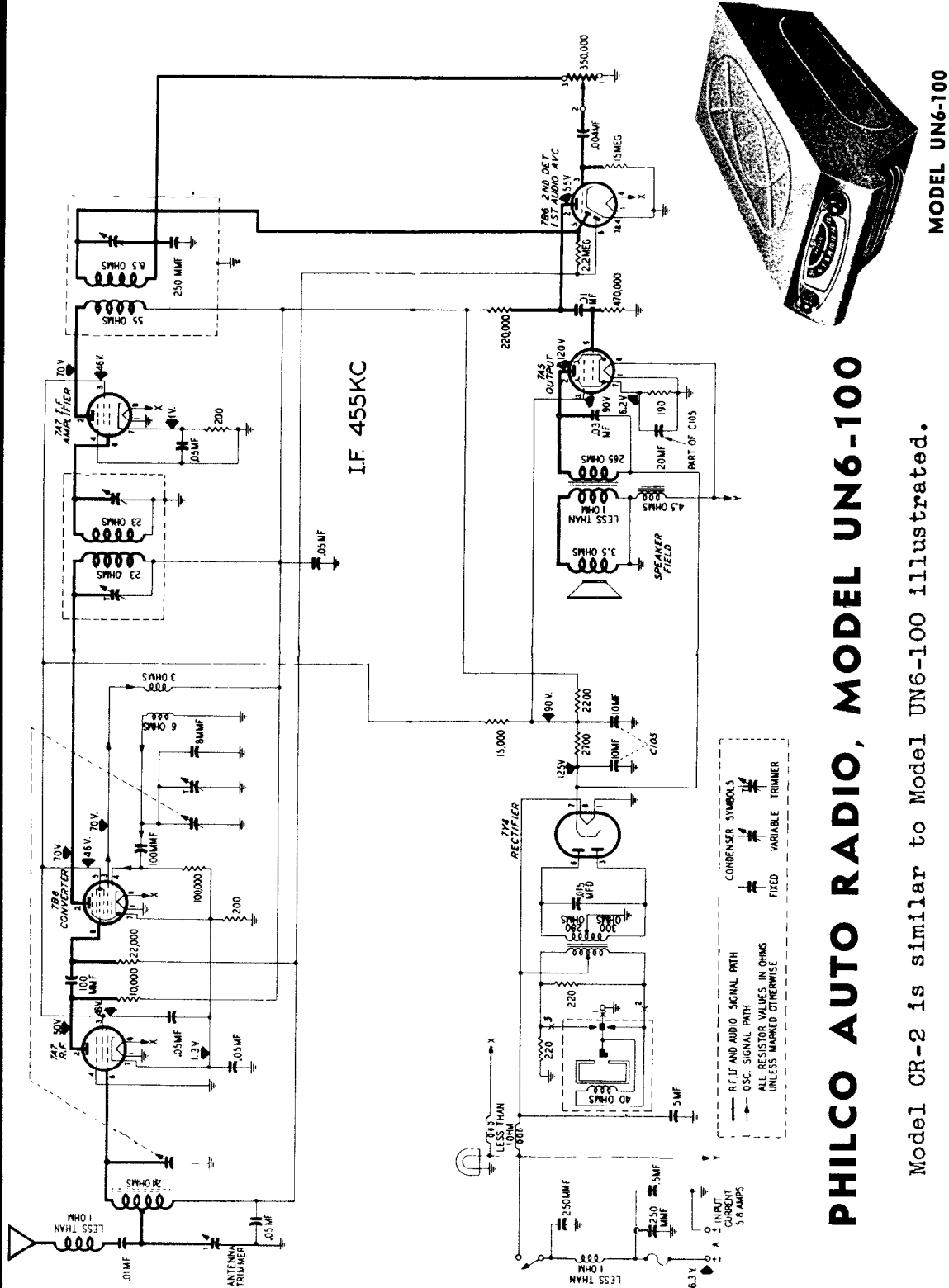

NOTE: All voltage, capacity, and resistance values show points indicated were measured with a 20,000 ohms-per-vo control at 550 kc.

SECTION 1

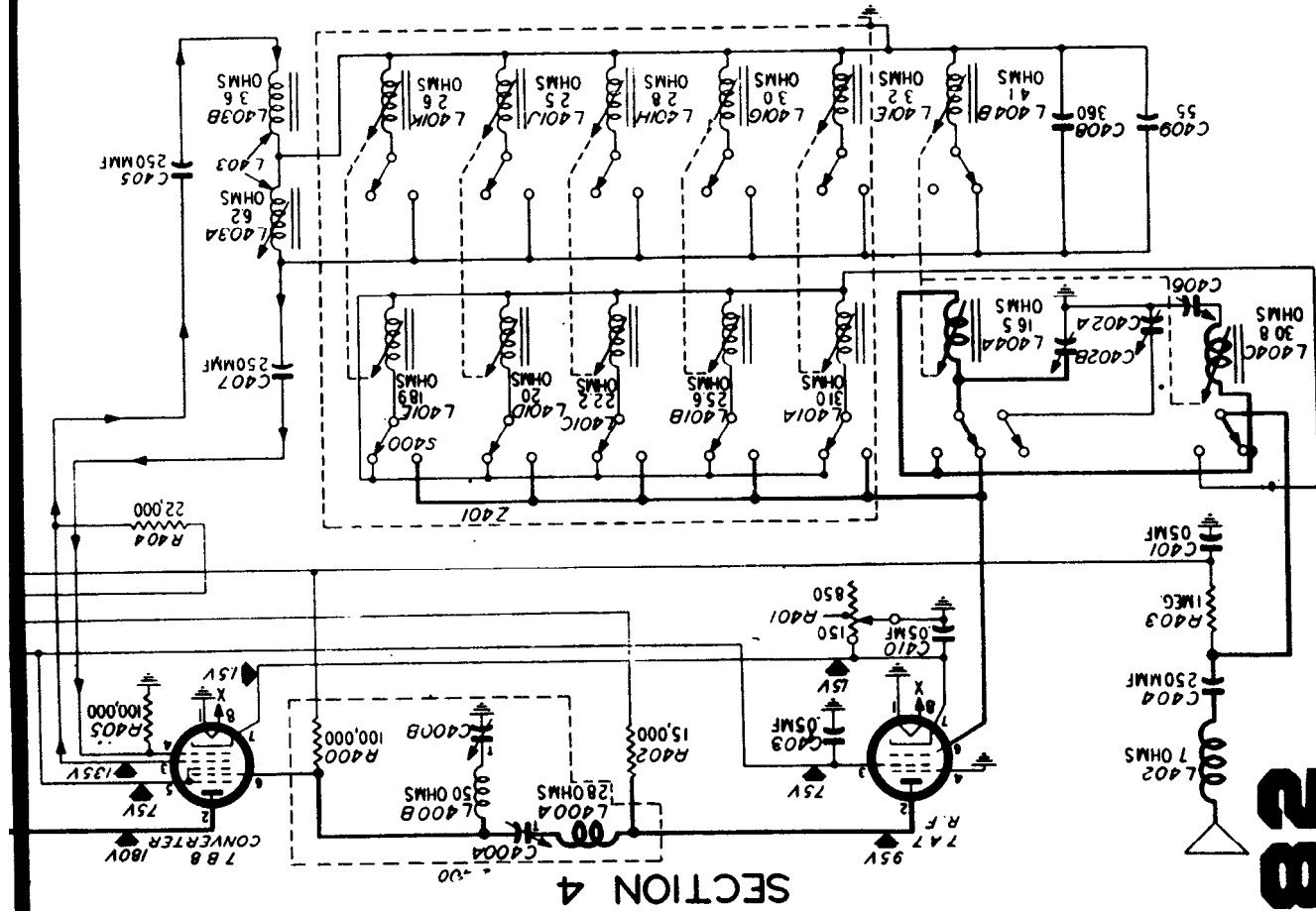
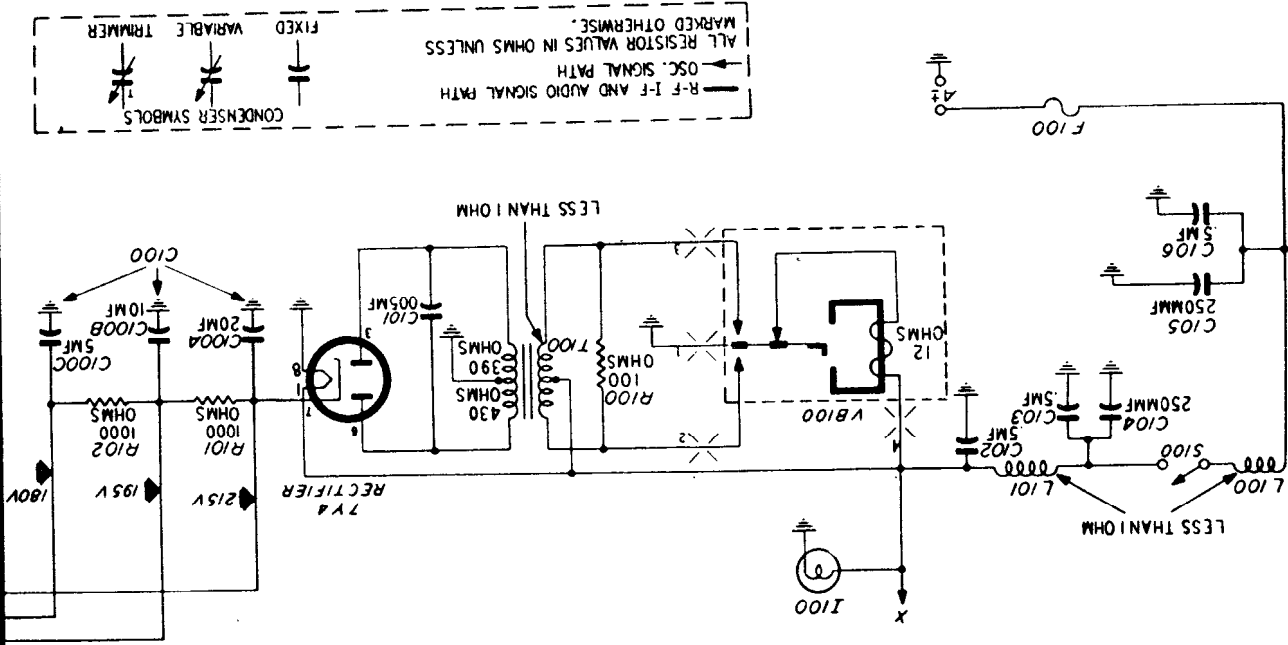

MANUAL OF 1949 MOST-OFTEN-NEEDED RADIO DIAGRAMS

CHRYSLER-PHILCO AUTO RADIO, MODEL C4608 MOPAR MODEL 802

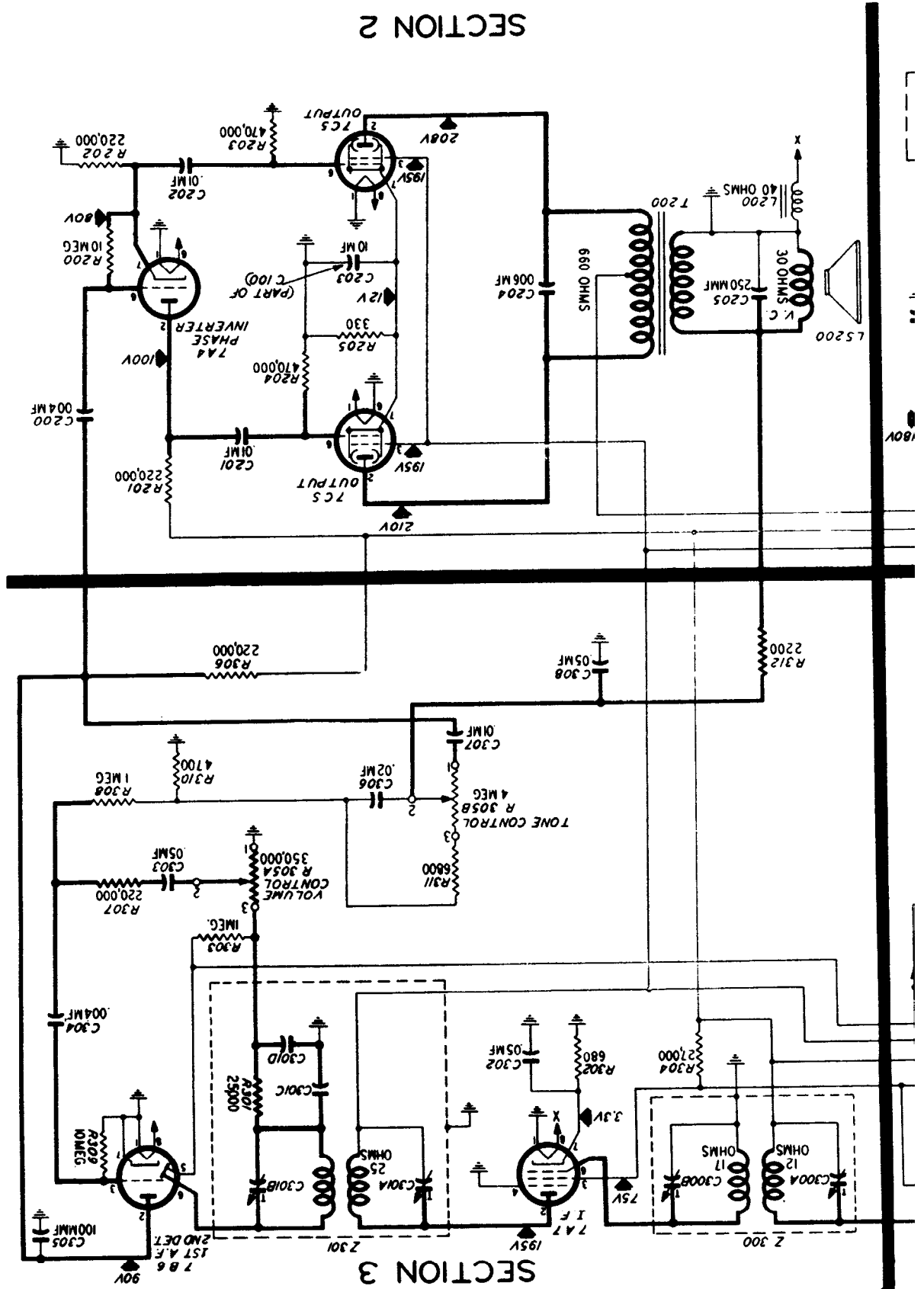

down are average. The voltages between B-(chassis) and other
voltage meter, with the volume control at minimum and the tuning
INTERMEDIATE FREQUENCY 455 kc.

MANUAL OF 1949 MOST-OFTEN-NEEDED RADIO DIAGRAMS

PHILCO AUTO RADIO MODELS CR-4 AND CR-6

Philco Auto Radio Models CR-4 and CR-6 are six-tube superheterodynes of the universal-mounting type. Both models are the same, with this exception: in the CR-4, the speaker is self-contained; in the CR-6, the speaker is separately mounted. The control heads are separately mounted. Custom-style control heads are available

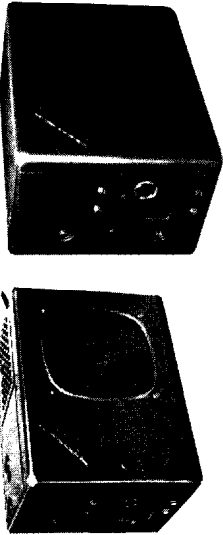

MODEL CR-4

MODEL CR-6

SPECIFICATIONS

CIRCUIT Six-tube superheterodyne
 FREQUENCY RANGE 535—1600 kc.
 INTERMEDIATE FREQUENCY 455 kc.
 AUDIO OUTPUT 3 watts (approx.)
 POWER INPUT 7 amperes at 6.6 volts, d.c.
 AERIAL Any Philco auto-radio aerial
 PHILCO TUBES (6)
 6BA6 (2), 6BE6, 6AY6, 7C5, 6X4

Philco Corporation

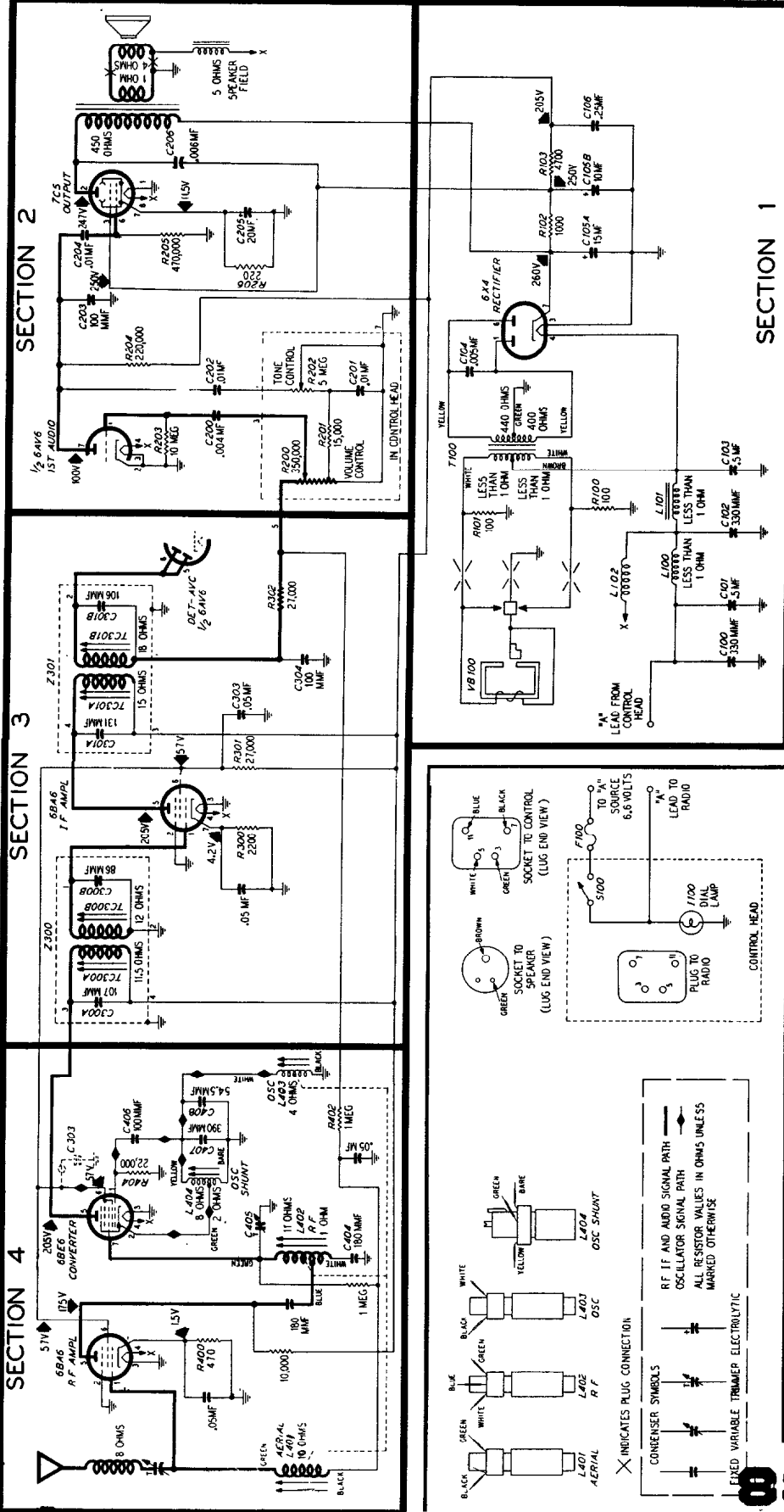

Philco Auto Radio Models CR-4 and CR-6, Schematic Diagram (Revised)

SECTION 4
RF AND CONVERTER CIRCUITS

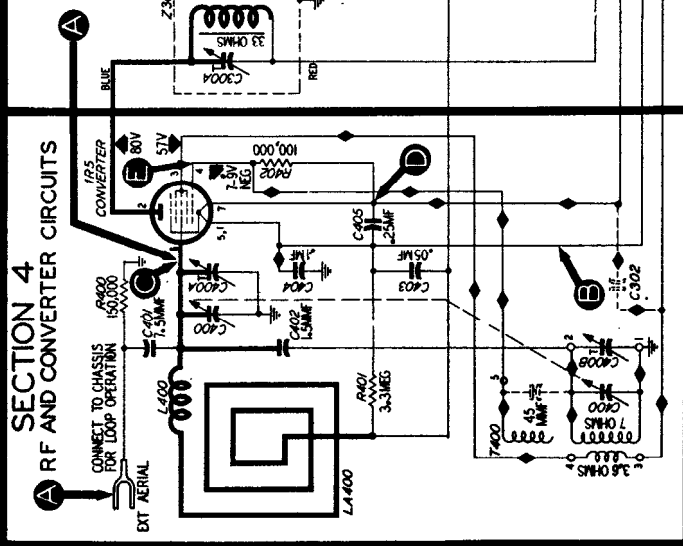

SECTION 3
IF DETECTOR AND AVC CIRCUITS

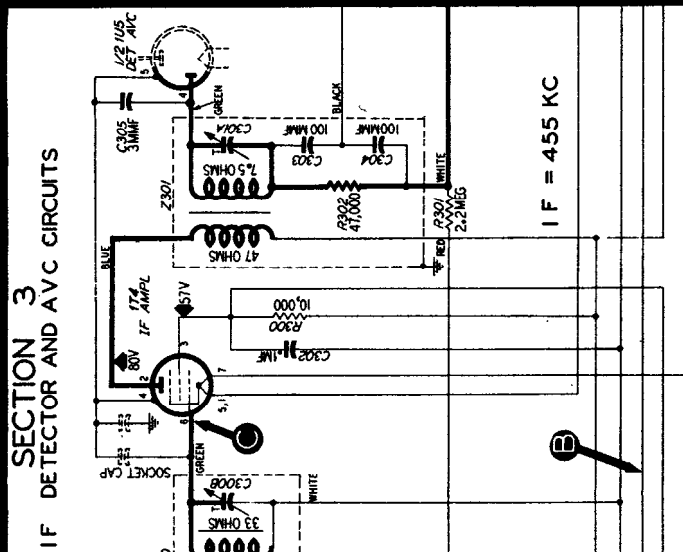

SECTION 2
AUDIO CIRCUITS

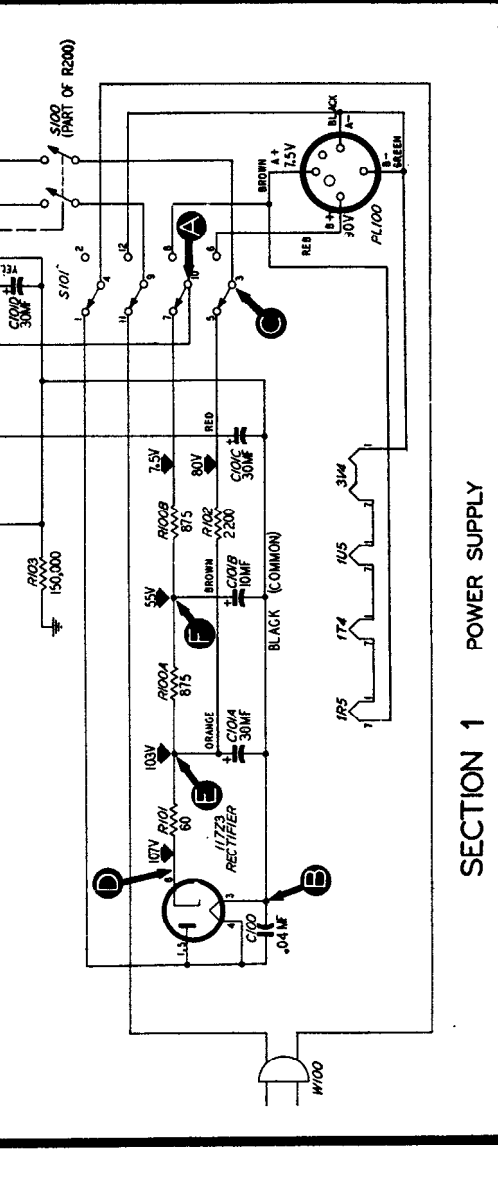
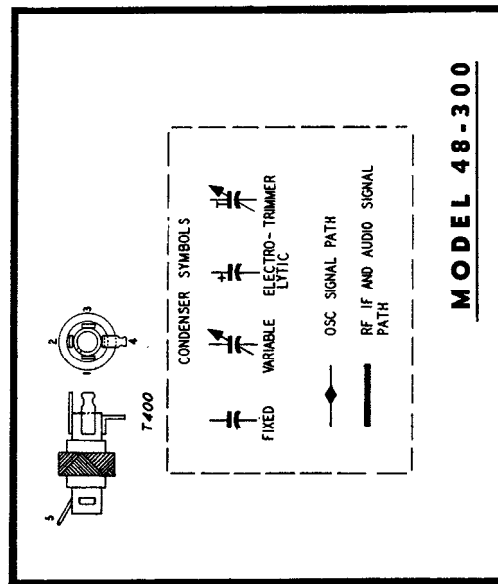
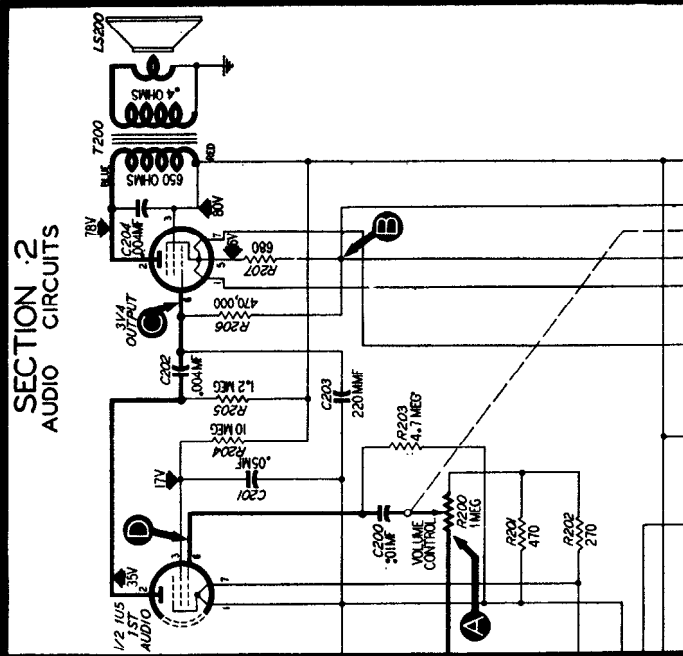

MODEL 48-300

SECTION 1 POWER SUPPLY

PHILCO RADIO MODEL 48-300, SECTIONALIZED SCHEMATIC DIAGRAM, SHOWING TEST POINTS

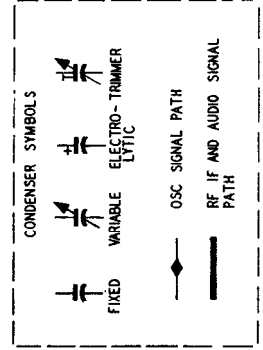

MANUAL OF 1949 MOST-OFTEN-NEEDED RADIO DIAGRAMS

Section 1

TROUBLE SHOOTING

POWER SUPPLY

Make the tests in this section with a d-c voltmeter connecting the leads between B-, test point B, and the test points indicated in the chart. The voltage readings given were taken with a 20,000-ohms-per-volt meter, at a line voltage of 117 volts, a.c.

With the power-cord plug connected to a source of power (a.c. or d.c.), turn on the control, and set the volume control to minimum (clockwise).

Follow the steps in the order given. If the "NORMAL INDICATION" is obtained in step 1, proceed with the tests for Section 2 (audio circuits); if not, isolate and correct the trouble in this section.

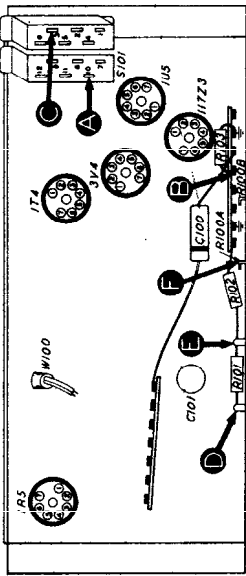

FIGURE 1. BOTTOM VIEW, SHOWING SECTION 1 TEST POINTS

STEP	TEST POINT	NORMAL INDICATION	ABNORMAL INDICATION	POSSIBLE CAUSE OF ABNORMAL INDICATION
1	A	7.5v	Low voltage	Trouble in this section. Isolate by the following tests.
2	C	00v	No voltage	Defective: 117Z2. Open: C101A.
3	D	107v	Low voltage	Defective: 117Z2. Open: R100, R101.
4	E	103v	No voltage	Changed Resistances: R101. Leaky: C101A.
5	F	55v	Low voltage	Open: R101. Shorted: C101A.
6	A	7.5v	No voltage	Open: R100A. Shorted: C101B.
7	C	00v	Low voltage	Open: R100A. Shorted: C101B.
8	E	103v	High voltage	Open filament of one or more tubes.
9	A	7.5v	Low voltage	Open: R100A. Shorted: C101B.
10	C	00v	High voltage	Changed Resistances: R102. Leaky: C101C.
11	E	103v	Low voltage	Open: R100A. Shorted: C101B.
12	A	7.5v	High voltage	Open: R100A. Shorted: C101B.
13	C	00v	No voltage	Open: R102. Shorted: C101C.

Listening Test: Hum may be caused by open C101C, C101D, or R103.

* This part located in another section, may cause abnormal indication in this section. BATTERY VOLTAGE: Replace battery when (with radio turned on) "B" voltage falls below 60 volts, or "A" voltage falls below 5 volts.

Section 2

TROUBLE SHOOTING

AUDIO CIRCUITS

For the tests in this section, use an audio-frequency signal generator. Connect the generator ground lead to B-, test point B; connect the output lead through a .1-mf. condenser to the test points indicated in the chart.

With the power-cord plug connected to a source of power (a.c. or d.c.), set the volume control to maximum (counterclockwise). Adjust the signal-generator output as required for each step.

If the "NORMAL INDICATION" is obtained in step 1, proceed with the tests for Section 3 (i-f, detector, and a-v-c circuits); if not, isolate and correct the trouble in this section.

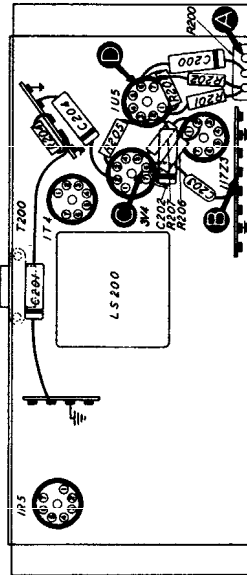

FIGURE 2. BOTTOM VIEW, SHOWING SECTION 2 TEST POINTS

STEP	TEST POINT	NORMAL INDICATION	POSSIBLE CAUSE OF ABNORMAL INDICATION
1	A	Load, clear signal with weak signal input.	Trouble in this section. Isolate by the following tests.
2	C	Clear signal with strong signal input.	Defective: 3V4, L8300. Open: R215, R207, T400. Shorted or leaky: C202, C205, C204, T400.
3	D	Same as step 1.	Defective: 1U5. Open: R204, R305. Shorted or leaky: C201, C203.
4	A	Same as step 1.	Open: R200 (locate through range), R201, R103, C300, R203, C304.

Listening Test: If speech or music is distorted (with section 1 operating normally), check R203, R201, and R202 for opens, and C200 for leakage.

* This part located in another section, may cause abnormal indication in this section.

Section 3

MODEL 48-300

I-F, DETECTOR, AND A-V-C CIRCUITS

For the tests in this section, use an r-f signal generator with modulated output, set at 455 kc. Connect the generated output lead to B-, test point B; connect the output lead through a .1-mf. condenser to the test points indicated in the chart.

With the power-cord plug connected to a source of power (a.c. or d.c.), set the volume control to maximum (counterclockwise).

If the "NORMAL INDICATION" is obtained in step 1, proceed with the tests for Section 4 (r-f and converter circuits); if not, isolate and correct the trouble in this section.

Since the circuit location of test point A for this section is the same as that of test point C for section 4, the effectiveness of step 1 as a master check is dependent upon the condition of certain parts in section 4; these parts are listed below under "POSSIBLE CAUSE OF ABNORMAL INDICATION."

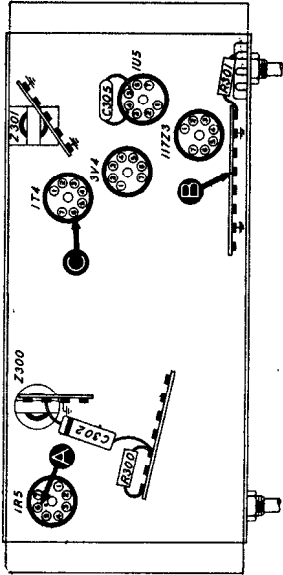

FIGURE 3. BOTTOM VIEW, SHOWING SECTION 3 TEST POINTS

STEP	TEST POINT	NORMAL INDICATION	POSSIBLE CAUSE OF ABNORMAL INDICATION
1	A	Load, clear signal with weak signal input.	Trouble in this section. Isolate by the following tests.
2	C	Load, clear signal with moderate signal input.	Defective: 17A. Open: R300, ZB1 pri. or sec., R302. Shorted: C300B, C301A, C303, C304.
3	A	Same as step 1.	Defective: 1R5. Shorted: C400. C400A. C300A, C300E. Open: Z300. pri. or sec., T400.

Listening Test: Oscillation or instability may be caused by open C305.

* This part located in another section, may cause abnormal indication in this section.

Section 4

R-F AND CONVERTER CIRCUITS

For the tests in this section, with the exception of the oscillator test, use an r-f signal generator, with modulated output. Connect the generator ground lead to B-, test point B; connect the output lead through a .1-mf. condenser to the test points indicated in the chart.

Set the volume control to maximum (counterclockwise).

Set the tuning control to maximum (counterclockwise) and signal-generator frequency as indicated in the chart.

If the "NORMAL INDICATION" is not obtained in step 1, isolate the trouble by following the remaining steps.

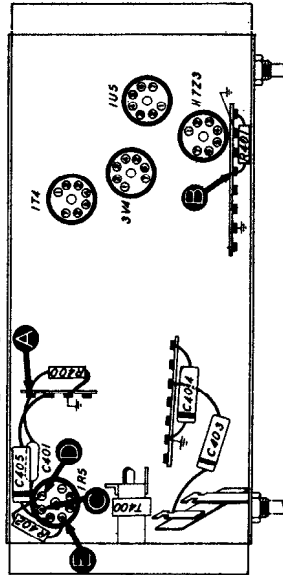
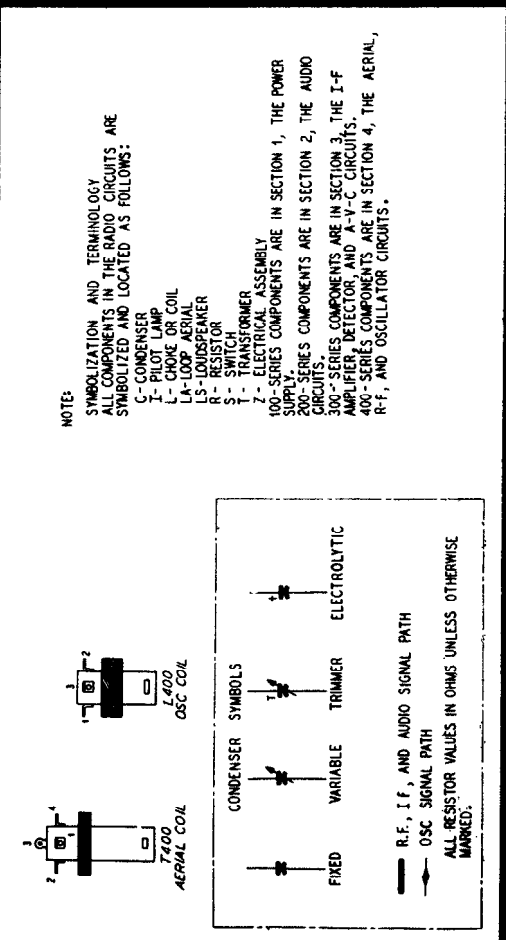
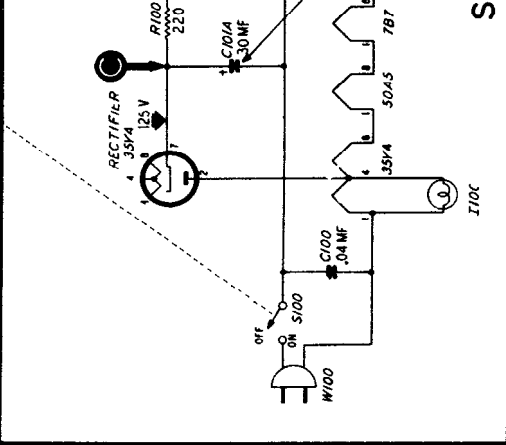
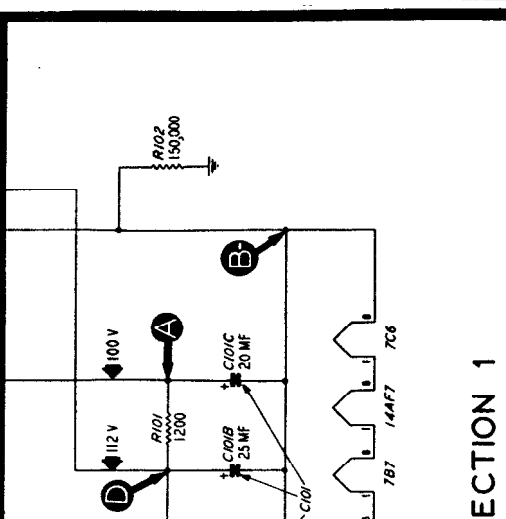
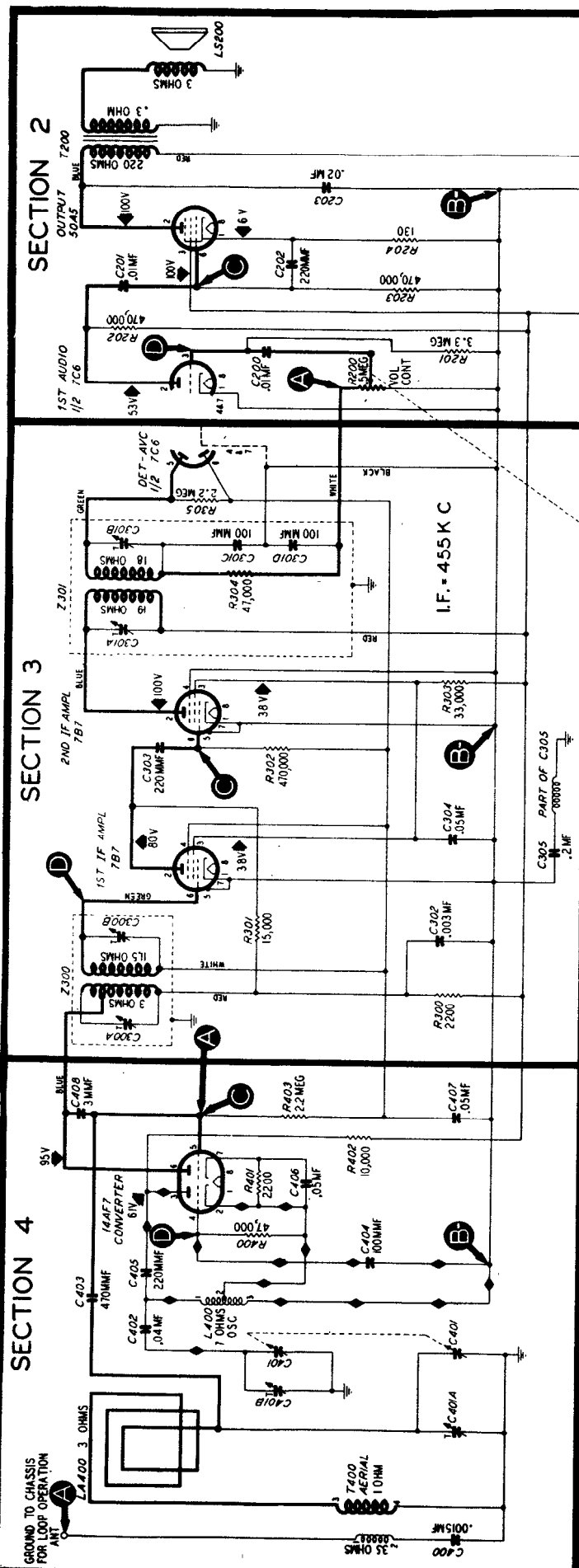

FIGURE 4. BOTTOM VIEW, SHOWING SECTION 4 TEST POINTS

STEP	TEST POINT	SIG. GEN. FREQ.	RADIO TUNING	NORMAL INDICATION	POSSIBLE CAUSE OF ABNORMAL INDICATION
1	A	1000 kc.	Tune to signal.	Load, clear signal with weak signal input.	Trouble in this section. Isolate by the following tests.
2	C	1000 kc.	Tune to signal.	Same as step 1.	Shorted: C400, C400A, C405, C402. Trouble in oscillator circuit (step 3).
3	E to D (Osc. test; see note below)		Rotate through range.	Negative 7 to 8 volts.	Defective: 1R5. Open: R402, T400. Shorted: C400, C408B.
4	A	1000 kc.	Tune to signal.	Same as step 1.	Open: C401, L400, LA400, R401.

OSCILLATOR TEST: Connect the positive lead of a high-resistance voltmeter to the 1R5 positive filament terminal, pin 7 (test point E); connect the pro end of the negative lead through a 100,000-ohm isolating resistor to the 1R5 oscillator grid, pin 4 (test point D). Use a suitable meter range, such as 0-10 volts. Absence of negative grid voltage throughout the tuning range indicates that the oscillator is not operating. The normal grid voltage given in the chart was measured with a 20,000-ohms-per-volt meter.



NOTE:
 SYMBOLIZATION AND TERMINOLOGY
 ALL COMPONENTS IN THE RADIO CIRCUITS ARE
 SYMBOLIZED AND LOCATED AS FOLLOWS:
 C - CONDENSER
 T - PILOT LAMP
 L - CHOKE OR COIL
 LA - LOOP AERIAL
 LS - LOUDSPEAKER
 R - RESISTOR
 S - SWITCH
 T - TRANSFORMER
 Z - ELECTRICAL ASSEMBLY
 100 - SERIES COMPONENTS ARE IN SECTION 1, THE POWER
 300 - SERIES COMPONENTS ARE IN SECTION 2, THE AUDIO
 CIRCUITS.
 300 - SERIES COMPONENTS ARE IN SECTION 3, THE I-F
 AMPLIFIER DETECTOR AND A-V-C CIRCUITS.
 400 - SERIES COMPONENTS ARE IN SECTION 4, THE AERIAL,
 R-F, AND OSCILLATOR CIRCUITS.

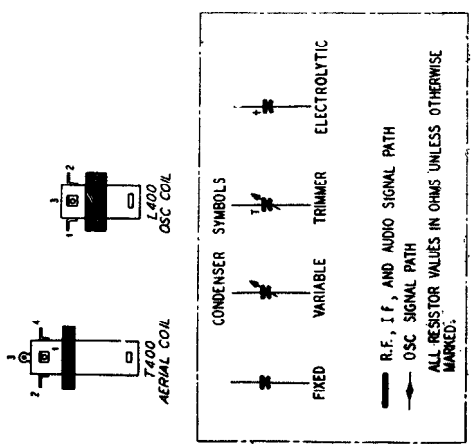

SECTION 1

SECTION 2

SECTION 3

SECTION 4

MANUAL OF 1949 MOST-OFTEN-NEEDED RADIO DIAGRAMS

PHILCO RADIO MODEL 48-461

Section 1 TROUBLE SHOOTING

For the tests in this section, use a d-c voltmeter; connect negative lead to test point B-, and positive lead to test points indicated in chart. The voltage readings given were taken with a 20,000-ohm-per-volt meter, at a line voltage of 117 volts, a.c.

Set volume control to minimum. Follow steps in sequence. If the "NORMAL INDICATION" is obtained in step 1, proceed with the tests for Section 2; if not, isolate and correct the trouble in this section.

It will be noted that certain parts in other sections of the radio are listed under "POSSIBLE CAUSE OF ABNORMAL INDICATION", since they may cause abnormal voltage readings in this section.

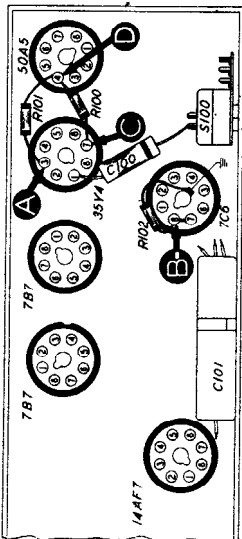

FIGURE 1. BOTTOM VIEW, SHOWING SECTION 1 TEST POINTS.

STEP	TEST POINT	NORMAL INDICATION	ABNORMAL INDICATION	POSSIBLE CAUSE OF ABNORMAL INDICATION
1	A	100v		Trouble in this section. Isolate by the following tests.
2	C	125v	Low voltage	Defective 35Y4. Leaky or open C101A. Shorted C101B. C101C. C203, or R100. Defective 35Y4. Shorted C101A.
3	D	112v	No voltage	Leaky C101B or C101C. Defective R100. Shorted C302. Shorted C101B. Open R100.
4	A	100v	Low voltage	Leaky C101C. Defective R101. Shorted C302. Shorted C101C. Open R101.

Listening Test: Abnormal hum may be caused by open C101A, C101B, or C101C.

Section 2 TROUBLE SHOOTING

For the tests in this section, use an audio-frequency signal generator. Connect generator ground lead to test point B-; connect output lead through .1-mf condenser to test points indicated in chart.

Set radio volume control to maximum. Adjust signal-generator output as required for each step.

If the "NORMAL INDICATION" is obtained in step 1, proceed with the tests for Section 3; if not, isolate and correct the trouble in this section.

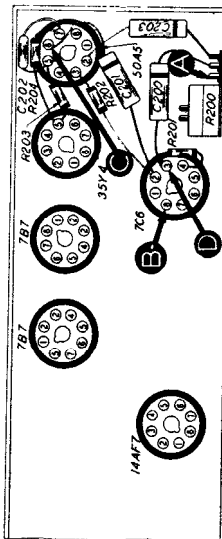

FIGURE 2. BOTTOM VIEW, SHOWING SECTION 2 TEST POINTS.

STEP	TEST POINT	NORMAL INDICATION	ABNORMAL INDICATION	POSSIBLE CAUSE OF ABNORMAL INDICATION
1	A	Load, clear signal with weak signal input.		Trouble in this section. Isolate by the following tests.
2	C	Moderate, clear signal with strong signal input.		Defective 50A5. L5200, T300, R204, or R203. Leaky C201 or C302.
3	D	Load, clear signal with weak signal input.		Defective 7C6, R202, or R201. Open, shorted, or leaky C201.
4	A	Load, clear signal with weak signal input.		Defective R200. Open C300.

Section 3 TROUBLE SHOOTING

For the tests in this section, use an r-f signal generator, with modulated output, set at 455 kc. Connect generator ground lead to test point B-; connect output lead through .1-mf condenser to test points indicated in chart.

Set radio volume control to maximum. If the "NORMAL INDICATION" is obtained in the first step, proceed with the tests for Section 4; if not, isolate and correct the trouble in this section.

It will be noted that for this section the circuit location of the test point for step 1 (the master check), and also for step 4, is the same as for test point C in Section 4; therefore, certain components in Section 4 may cause an abnormal indication.

"POSSIBLE CAUSE OF ABNORMAL INDICATION". These components are listed under

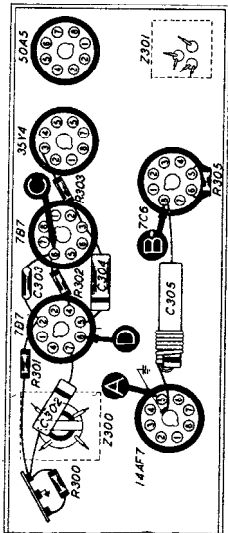

FIGURE 3. BOTTOM VIEW, SHOWING SECTION 3 TEST POINTS.

STEP	TEST POINT	NORMAL INDICATION	POSSIBLE CAUSE OF ABNORMAL INDICATION
1	A	Load, clear signal with weak signal input.	Trouble in this section. Isolate by the following tests.
2	C	Load, clear signal with moderate signal input.	Defective 7B7 (and 1/2 amp.) or R305. Open R302. Shorted C304. Misaligned Z301.
3	D	Load, clear signal with weak signal input.	Defective 7B7 (and 1/2 amp.). Open or leaky C302. Shorted C302. Open R300 or R301.
4	A	Load, clear signal with weak signal input.	Defective 14AF7. Defective or misaligned Z300. Open C302. R300, R401, or R402. Shorted C302.

Section 4 TROUBLE SHOOTING

For the tests in this section, with the exception of the oscillator test, use an r-f signal generator with modulated output. Connect generator ground lead to test point B-; connect output lead through .1-mf condenser to test points indicated in chart.

Set radio volume control to maximum. Set tuning control and signal-generator frequency as indicated in chart.

If the "NORMAL INDICATION" is not obtained in step 1, isolate the trouble by proceeding with the remaining steps.

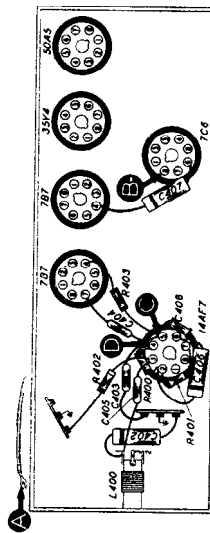

FIGURE 4. BOTTOM VIEW, SHOWING SECTION 4 TEST POINTS.

STEP	TEST POINT	DIAL SETTINGS	NORMAL INDICATION	POSSIBLE CAUSE OF ABNORMAL INDICATION
1	A	1000 kc SHG. GEN. 1000 kc RADIO	Load, clear signal with weak signal input.	Trouble in this section. Isolate by the following tests.
2	C	1000 kc	Load, clear signal with weak signal input.	Defective 14AF7. Open C400. Shorted or leaky C400. Trouble in oscillator circuit (see step 3).
3	D	Turn tuning control through range.	Negative 1 to 2 volts.	Defective 14AF7 or L400. Open or shorted C404 or C405. Open R400, R402, or C402. Shorted plates of tuning condenser (see section).
4	A	1000 kc	Load, clear signal with weak signal input.	Defective T400 or L4400. Open C403 or C400. Shorted plates of tuning condenser (see section).

NOTE: Connect positive lead of high-resistance d-c voltmeter to test point B-; connect grid lead of negative lead through 100,000-ohm isolating resistor to oscillator grid, test point D. Use suitable meter range, such as 0-10 volts. Proper operation of oscillator is indicated by negative voltage throughout range of tuning condenser.

The components in the radio circuit are symbolized according to the types of parts and the sections of the radio in which the parts are located. The prefix letter of the symbol designates the type of part, as follows:

C—condenser
 L—loop aerial
 LA—loop aerial
 LS—loud-speaker
 P—pilot lamp
 L—choke or coil
 B—resistor
 S—switch
 T—transformer
 W—power cord and plug
 Z—electrical assembly

BE, IF, AND AUDIO SIGNAL PATH
 OSCILLATOR PATH

NOTE: ALL RESISTANCE VALUES IN OHMS UNLESS OTHERWISE MARKED.

CONDENSER SYMBOLS
 VARIABLE
 TRIMMER
 ELECTROLYTIC
 FIXED

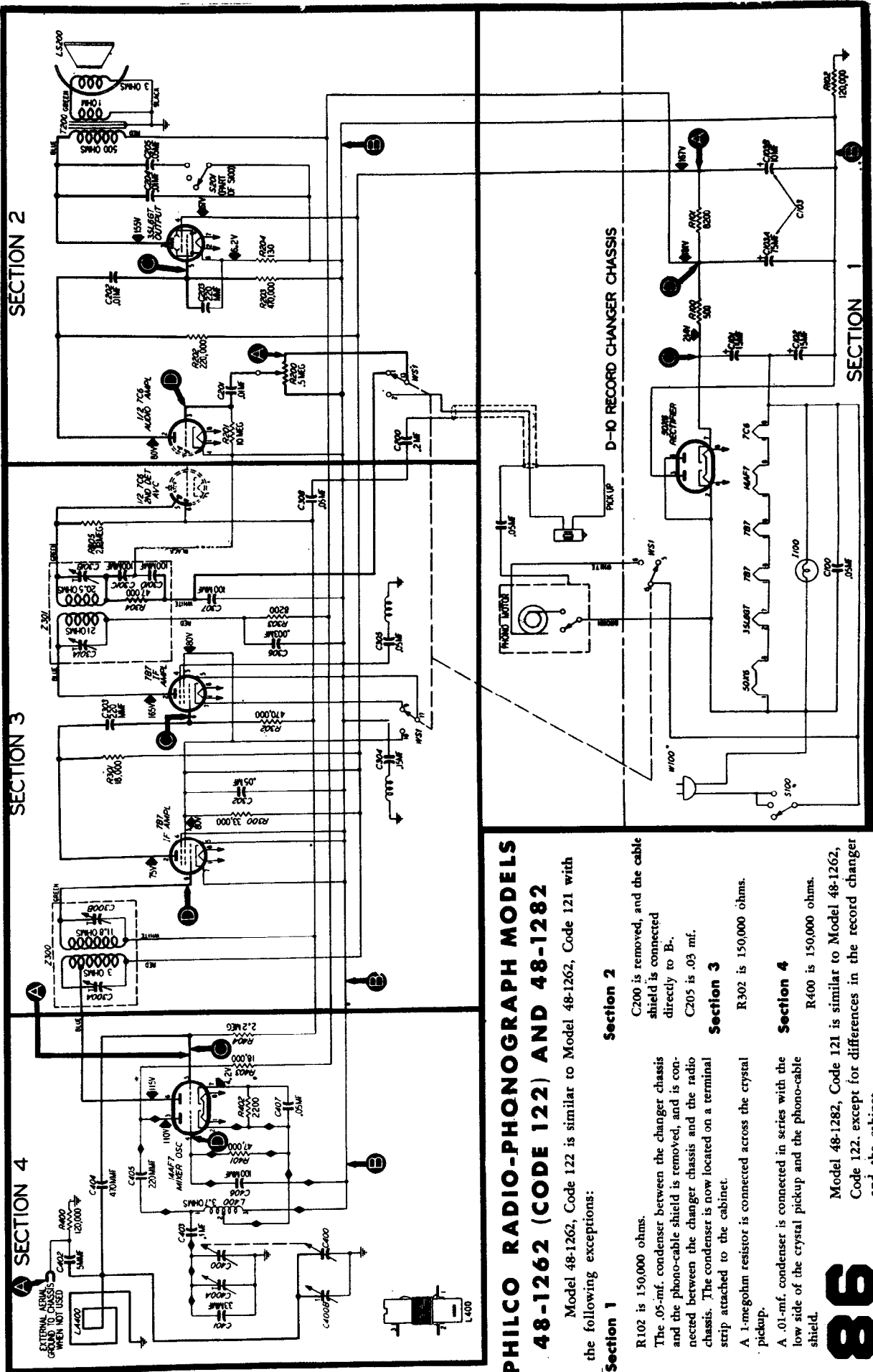

PHILCO RADIO-PHONOGRAPH MODELS 48-1262 (CODE 122) AND 48-1282

Model 48-1262, Code 122 is similar to Model 48-1262, Code 121 with the following exceptions:

- Section 1**
 R102 is 150,000 ohms.
 The .05-mf. condenser between the changer chassis and the phono-cable shield is removed, and is connected between the changer chassis and the radio chassis. The condenser is now located on a terminal strip attached to the cabinet.
 - Section 2**
 C200 is removed, and the cable shield is connected directly to B.
 C205 is .03 mf.
 - Section 3**
 R302 is 150,000 ohms.
 - Section 4**
 R400 is 150,000 ohms.
- Model 48-1282, Code 121 is similar to Model 48-1262, Code 122, except for differences in the record changer and the cabinet.

86

MANUAL OF 1949 MOST-OFTEN-NEEDED RADIO DIAGRAMS

PHILCO RADIO-PHONOGRAPH, MODEL 48-1262

Section 1

TROUBLE SHOOTING

For the tests in this section, use a d-c voltmeter. Connect the negative lead to the B— bus, test point B; connect the positive lead to the test points indicated in the chart. The voltage readings given were taken with a 20,000-ohms-per-volt meter, at a line voltage of 117 volts, a.c.
With the radio-phonograph switch set to the radio position, turn the volume control to maximum, and turn the tone control fully clockwise.

Follow the steps in sequence; if the "NORMAL INDICATION" is obtained in step 1, proceed with the tests for Section 2; if not, isolate and correct the trouble in this section.

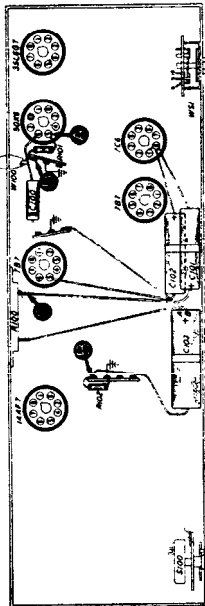

Figure 1. Bottom View, Showing Section 1 Test Points

STEP	TEST POINT	NORMAL INDICATION	ABNORMAL INDICATION	POSSIBLE CAUSE OF ABNORMAL INDICATION
1	A	167 v.	No voltage. Low voltage.	Trouble within this section. Isolate by the following tests. Defective: 5X16, 5J100, W100. Shorted: C101, C103, C103B, R204. Open: C101, C102, C102, C102A, C103A, C103B, R204.* R204.*
2	C	214 v.	High voltage.	Shorted: C103A.
3	D	181 v.	No voltage. Low voltage. High voltage.	Open: C103A, Leaky: C103A, C204.* Open: R101, R204, T200.* Shorted: C103B. Leaky: C103B. Open: R204, T200.*
4	A	167 v.	No voltage. Low voltage. High voltage.	Listening Test: Abnormal hum may be caused by open C103A, C103B, or R102.

* This part, located in another section, may cause abnormal indication in this section.

Section 2

TROUBLE SHOOTING

For the tests in this section, use an audio-frequency signal generator. Connect the generator ground lead to the B— bus, test point B; connect the generator output lead through a .1-mf. condenser to the test points indicated in the chart.
Set the volume control to maximum, and the tone control fully clockwise. Adjust the signal-generator output as required for each step.

If the "NORMAL INDICATION" is obtained in step 1, proceed to the tests in Section 3; if not, isolate and correct the trouble in this section.

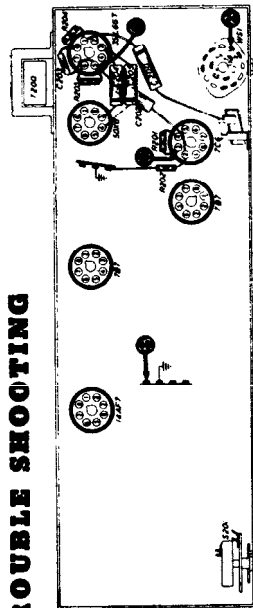

Figure 2. Bottom View, Showing Section 2 Test Points

STEP	TEST POINT	NORMAL INDICATION	ABNORMAL INDICATION	POSSIBLE CAUSE OF ABNORMAL INDICATION
1	A	Loud, clear signal with weak signal input.	Trouble within this section. Isolate by the following tests.	Trouble within this section. Isolate by the following tests.
2	C	Loud, clear signal with strong signal input.	Defective: 35L6CT, 1S200, T200. Shorted: C202, C203, C204, C205. Leaky: C203, C204, C205. Open: R203, R204.	Defective: 35L6CT, 1S200, T200. Shorted: C202, C203, C204, C205. Leaky: C203, C204, C205. Open: R203, R204.
3	D	Loud, clear signal with weak signal input.	Defective: 7C6. Open: C202, R202, R201. Leaky: C202.	Defective: 7C6. Open: C202, R202, R201. Leaky: C202.
4	A	Loud, clear signal with weak signal input. (Rotate R200 through its range).	Defective: W51, R200. Open: C201. Shorted: C301D.*	Defective: W51, R200. Open: C201. Shorted: C301D.*

Listening Test: Distortion on strong signals may be caused by short-circuited or leaky C201, or open-circuited R201.

* This part, located in another section, may cause abnormal indication in this section.

Section 3

TROUBLE SHOOTING

For the tests in this section, use an r-f signal generator, with modulated output, set at 455 kc. Connect the generator ground lead to the B— bus, test point B; connect the generator output lead through a .1-mf. condenser to the test points indicated in the chart.

Set the radio-phonograph switch to radio, turn the volume control to maximum, and set the tone control fully clockwise.

If the "NORMAL INDICATION" is obtained in step 1, proceed with the tests for Section 4; if not, isolate and correct the trouble in this section.

NOTE: Since the circuit location of test point A for this section is the same as that of test point C for Section 4, the effectiveness of step 1 as a master check is dependent upon the condition of certain parts in

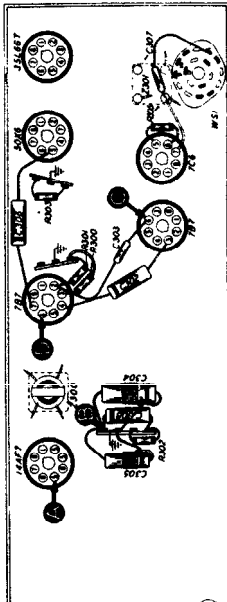

Figure 3. Bottom View, Showing Section 3 Test Points

Section 4; these parts are listed below under "POSSIBLE CAUSE OF ABNORMAL INDICATION."

STEP	TEST POINT	NORMAL INDICATION	ABNORMAL INDICATION	POSSIBLE CAUSE OF ABNORMAL INDICATION
1	A	Loud, clear signal with weak signal input.	Loud, clear signal with strong signal input.	Trouble within this section. Isolate by the following tests. Defective: W51, 7B7 (2nd 1/2), 7C6, Z301. Open: C302, C306, R300, R302. Shorted: C302, C306. Leaky: C302, C306.
2	C	Loud, clear signal with moderate signal input.	Loud, clear signal with weak signal input.	Defective: 7B7 (1st 1/2). Open: C303, C394, C305, C306, R301, R302. Shorted: C303. Leaky: C303.
3	D	Loud, clear signal with weak signal input.	Loud, clear signal with weak signal input.	Defective: 1A4F7,* Z300. Misaligned: Z300. Open: R402,* R401.*

* This part, located in another section, may cause abnormal indication in this section.

Section 4

TROUBLE SHOOTING

For the tests in this section (with the exception of the oscillator test), use an r-f signal generator with modulated output. Connect the generator ground lead to the B— bus, test point B; connect the generator output lead through a .1-mf. condenser to the test points indicated in the chart.

Set the radio-phonograph switch to radio, turn the volume control to maximum, and set the tone control fully clockwise. Except as noted for the oscillator test, set the radio and signal-generator dials to 540 kc.

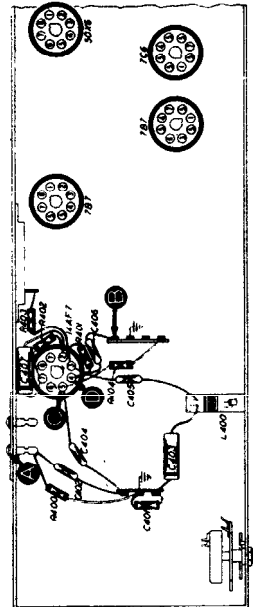

Figure 4. Bottom View, Showing Section 4 Test Points

STEP	TEST POINT	NORMAL INDICATION	ABNORMAL INDICATION	POSSIBLE CAUSE OF ABNORMAL INDICATION
1	A	Loud, clear signal with weak signal input.	Loud, clear signal with weak signal input.	Trouble within this section. Isolate by the following tests. Defective: 1A4F7, osc. circuit. Open: C407, R402. Shorted: C407. Leaky: C407.
2	C	Loud, clear signal with weak signal input.	Loud, clear signal with weak signal input.	Defective: L400. Open: C403, C405, C406, R401, R403. Shorted: C400, C400A, C401, C402, C405, C406.
3	D (One test; see Note below.)	Negative 3.3 to 4.2 volts.	Loud, clear signal with weak signal input.	Defective: 1A400. Shorted: C400, C400A, C402, C404. Open: C402, C403. Leaky: C402, C404.
4	A	Loud, clear signal with weak signal input.	Loud, clear signal with weak signal input.	Defective: L400. Open: C403, C405, C406, R401, R403. Shorted: C400, C400A, C401, C402, C405, C406.

OSCILLATOR-TEST NOTE: Connect positive lead of high-resistance d-c voltmeter to B— bus, test point B; connect prod end of negative lead through 100,000-ohm isolating resistor to oscillator grid, test point D. Use suitable meter range, such as 0–10 volts. Proper operation of oscillator is indicated by negative voltage of 3.3 to 4.2 volts (measured with 20,000-ohms-per-volt meter) throughout range of tuning control.

SYMBOLIZATION

STEP	SIGNAL GENERATOR		RADIO		ADJUST
	CONNECTIONS TO RADIO	DIAL SETTING	DIAL SETTING	SPECIAL INSTRUCTIONS	
1	Ground lead to B-1 output lead through .1-mf. condenser to terminal 1 of TB401.	455 kc.	540 kc.	Adjust trimmers ONCE ONLY, in the order given, for maximum output.	C302A C301D *C300C TC300
2	Radiating loop (see note *).	1600 kc.	1600 kc.	Adjust for maximum.	C413A
3	Same as step 2.	1500 kc.	1500 kc.	Adjust for maximum.	C413B

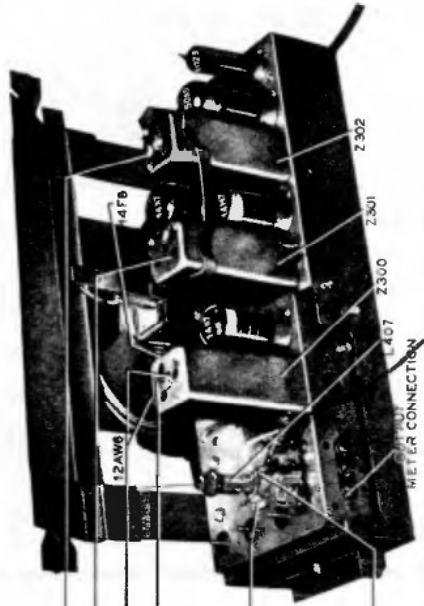

Figure 8. Top View, Showing AM Trimmer Locations

FM ALIGNMENT CHART

STEP	SIGNAL GENERATOR		RADIO		ADJUST
	CONNECTIONS TO RADIO	DIAL SETTING	DIAL SETTING	SPECIAL INSTRUCTIONS	
1	Through .1-mf. condenser to pin 1 of 12AW6 tube (test point E).	9.1 mc.	88 mc.	Adjust for maximum d-c meter reading; attenuate signal to maintain approximately 10-volt reading. Repeat until no further improvement is noted. After this step, do not touch any of these trimmers except C302C (in step 3).	C302C TC302 C301C C301A
2	Through .1-mf. condenser to pin 8 of 14F8 tube (test point C).	9.1 mc.	88 mc.	Adjust for maximum d-c meter reading; attenuate signal to maintain approximately 10-volt reading. Repeat until no further improvement is noted. After this step, do not touch these trimmers.	C300B C300A
3	Same as step 2.	9.1 mc.	88 mc.	Double-check adjustment of C302C to make certain that minimum audio output is obtained. This is a critical adjustment; turn trimmer very slowly.	C302C
4	To pin 3 of J400.	105 mc.	105 mc.	Maximum d-c meter reading. This is the oscillator high-frequency trimmer adjustment.	C400C
5	Same as step 4.	105 mc.	105 mc.	Adjust for maximum while rocking tuning control.	C400B
6	Same as step 4.	105 mc.	105 mc.	Adjust for maximum.	C400A
7	Same as step 4.	92 mc.	92 mc.	Adjust L403 (see ADJUSTING R.F. COILS).	
8	Same as step 4.	92 mc.	92 mc.	Adjust L402 (see ADJUSTING R.F. COILS).	
9	Same as step 4.	92 mc.	92 mc.	Adjust L400 (see ADJUSTING R.F. COILS).	
10	Repeat steps 4 through 9 until no further increase is obtained.				

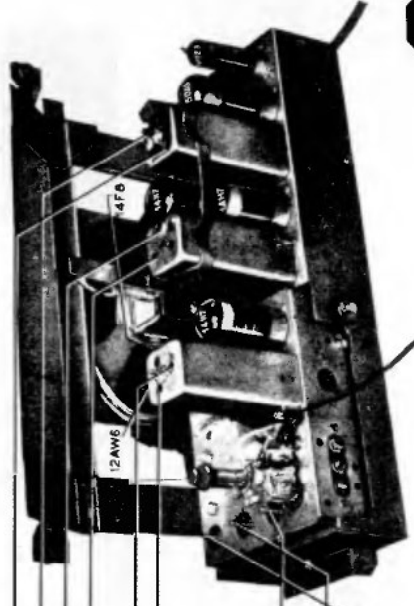
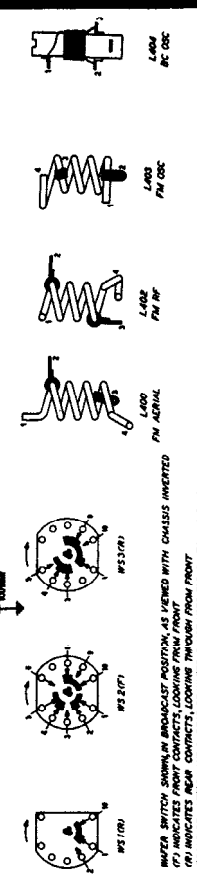
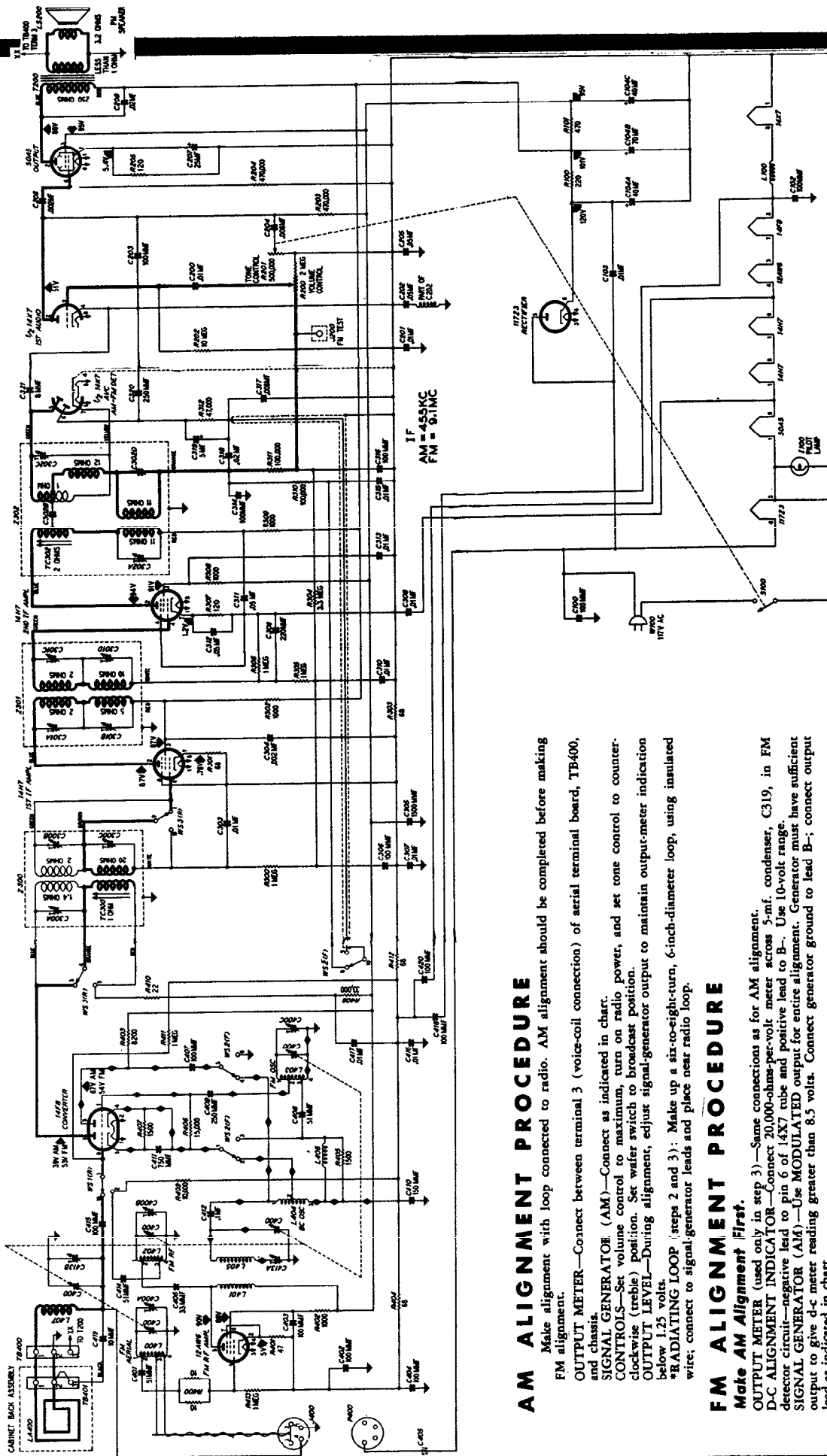

Figure 9. Top View, Showing FM Trimmer Locations

MANUAL OF 1949 MOST-OFTEN-NEEDED RADIO DIAGRAMS

PHILCO RADIO MODELS 48-472 AND 48-472-1



WAFFER SWITCH SHOWN IN BROADCAST POSITION, AS VIEWED WITH CHASSIS INVERTED
 P1-P10 INDICATES POINTS, LOOKING THROUGH FRONT
 POINT OF METER 2, NOT USED FOR SWITCHING BANDS

AM ALIGNMENT PROCEDURE

Make alignment with loop connected to radio. AM alignment should be completed before making FM alignment.
OUTPUT METER—Connect between terminal 3 (voice-coil connection) of aerial terminal board, TB400, and chassis.
SIGNAL GENERATOR (AM)—Connect as indicated in chart.
CONTROLS—Set volume control to maximum, turn on radio power, and set tone control to counter-clockwise (treble) position. Set wafer switch to broadcast position.
OUTPUT LEVEL—During alignment, adjust signal-generator output to maintain output-meter indication below 1.25 volts.
RADIATING LOOP (steps 2 and 3): Make up a six-to-eight-turn, 6-inch-diameter loop, using insulated wire; connect to signal-generator leads and place near radio loop.

FM ALIGNMENT PROCEDURE

Make AM Alignment First.
OUTPUT METER (used only in step 3)—Same connections as for AM alignment.
D-C ALIGNMENT INDICATOR—Connect 70,000-ohm-per-volt meter across 5-mf. condenser, C319, in FM detector circuit—negative lead to pin 6 of 14X7 tube and positive lead to B—. Use 10-volt range.
SIGNAL GENERATOR (AM)—Use MODULATED output for entire alignment. Generator must have sufficient output to give d-c meter reading greater than 8.5 volts. Connect generator ground to lead B—; connect output lead as indicated in chart.
CONTROLS—Same settings as for AM alignment, except wafer switch, which should be set to FM position. Allow radio and generator to warm up for 15 minutes before starting alignment.
ADJUSTING R-F COILS: In steps 7, 8, and 9, the resonance of the circuits using coils L400, L402, and L403 may be checked by the use of a powdered-iron tuning core, such as Part No. 56-6100. If the signal strength (meter reading) increases when the iron end is inserted in the coil, compress the turns slightly. If the signal strength increases when the brass end is inserted, spread the turns. If the signal strength decreases when either the brass or iron end is inserted, no adjustment of the coil is necessary. Do not spread or compress turns excessively, since only a small change is required at these frequencies.
 Oscillator coil, L403: Adjust coil for maximum meter reading.
 R-f coil, L402: Adjust coil for maximum meter reading while rocking tuning control.
 Aerial coil, L400: Adjust coil for maximum meter reading.

AM ALIGNMENT CHART

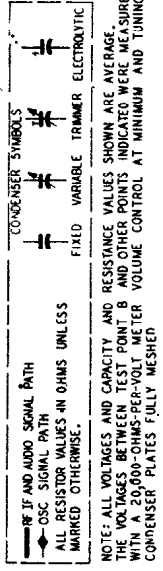
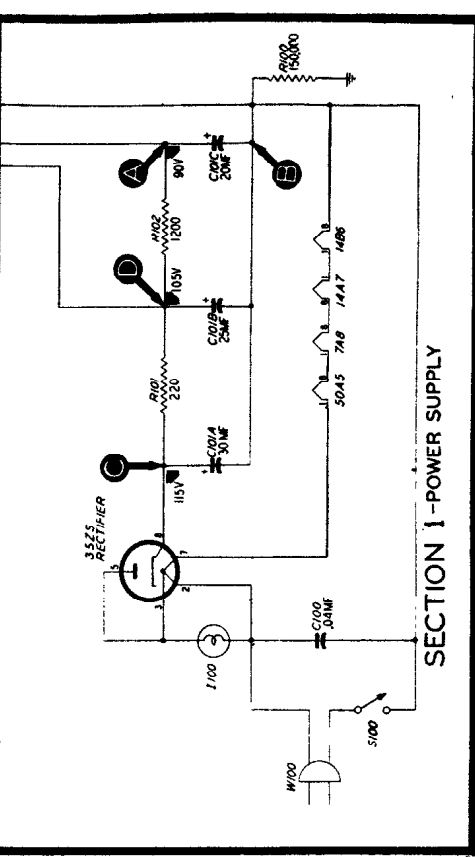
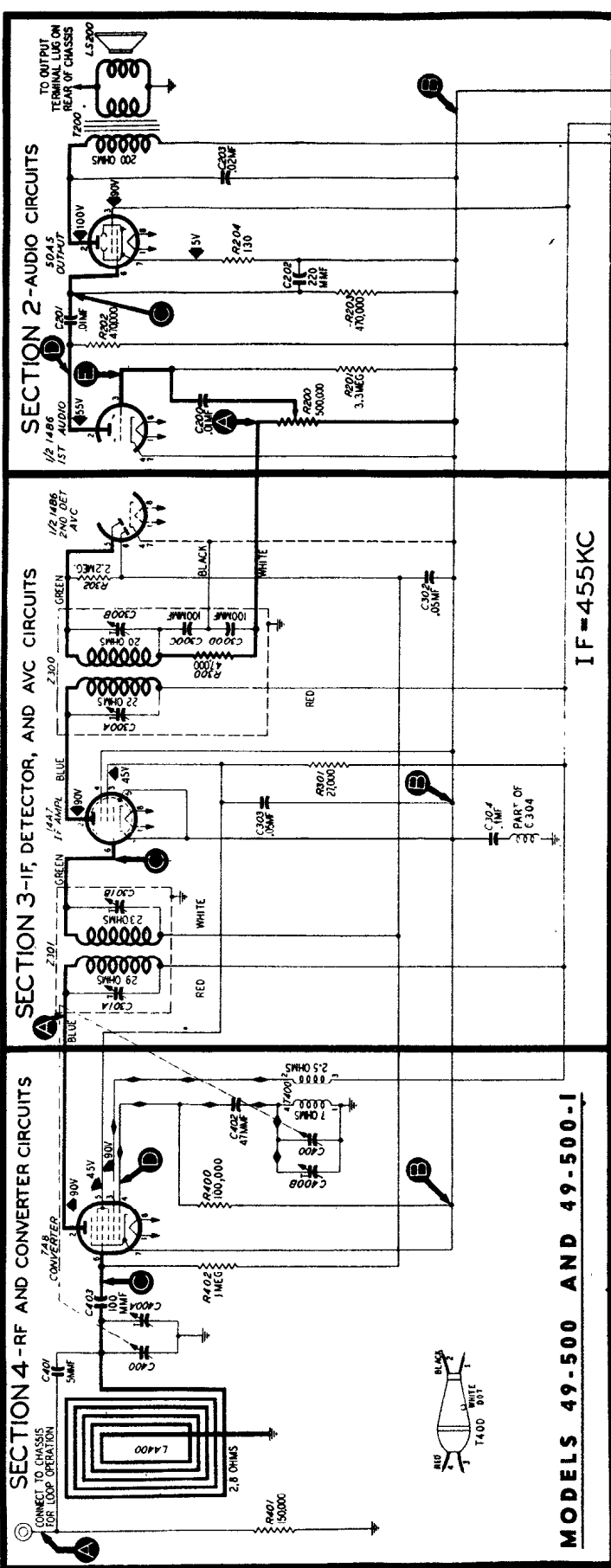

NOTE: ALL VOLTAGES AND CAPACITY AND RESISTANCE VALUES SHOWN ARE AVERAGE. TEST POINTS A AND B AND OTHER POINTS INDICATED WERE MEASURED WITH AN AC VOLTMETER. ALL METERS VOLUME CONTROL AT MINIMUM AND TUNING CONDENSER PLATES FULLY MESHED.

Several Philco 5-tube radios use circuits similar to the model illustrated. Such similar sets are: Models 49-501, 49-503, 49-504, and 49-505

MODEL 49-506

Philco Model 49-506 is a 5-tube superheterodyne. This set employs the same chassis as that used in Models 49-500 and 49-500-1, but is housed in a new-style cabinet which is supplied in either of two finishes, walnut or mahogany.



88

PHILCO RADIO MODELS 49-500 AND 49-500-1, SECTIONALIZED SCHEMATIC DIAGRAM, SHOWING TEST POINTS

MANUAL OF 1949 MOST-OFTEN-NEEDED RADIO DIAGRAMS

PHILCO RADIO MODELS 49-580 AND 47-500-1

Section 1 — Power Supply

For the tests in this section, use a d-c voltmeter; connect the leads to the test points indicated in the chart. The voltages shown were taken with a 20,000-ohms-per-volt meter at a line voltage of 117 volts, 60 cycles.

Turn the volume control to minimum, and set the dial pointer at 540 kc. If the "NORMAL INDICATION" is obtained in step 1, proceed with tests for Section 2 (audio circuits); if not, isolate and correct the trouble within this section.

TROUBLE SHOOTING

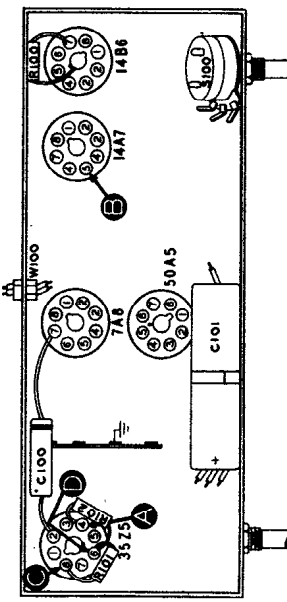

FIGURE 1. BOTTOM VIEW, SHOWING SECTION 1 TEST POINTS

STEP	TEST POINT	NORMAL INDICATION	ABNORMAL INDICATION	POSSIBLE CAUSE OF ABNORMAL INDICATION
1	A to B	80v	No voltage	Trouble within this section; isolate by the following tests.
2	C to B	115v	Low voltage	Defective: 3525GT, Shorted: C181A, C101A, or 1168. Leaky: C101A.
3	D to B	105v	High voltage	Open: R101.
4	A to B	80v	No voltage	Shorted: C181B.
			Low voltage	Open: C101A, Leaky: C101B or C203.
			High voltage	Open: R102, T203, or R204.
			No voltage	Shorted: C101C.
			Low voltage	Leaky: C101C.
			High voltage	Open: R204.

Listening Test: Abnormal hum may be caused by open C101A, C101B, or C101C.

Section 2 — Audio Circuits

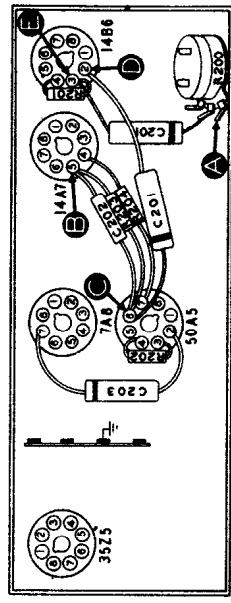

FIGURE 2. BOTTOM VIEW, SHOWING SECTION 2 TEST POINTS

STEP	TEST POINT	NORMAL INDICATION	ABNORMAL INDICATION	POSSIBLE CAUSE OF ABNORMAL INDICATION
1	A	Low, clear signal with weak signal-generator input.	Trouble within this section; isolate by the following tests.	Trouble within this section; isolate by the following tests.
2	C	Clear signal with weak signal-generator input.	No signal — Open or shorted: 80A8 or 15200. Shorted: C282.	No signal — Open or shorted: 15202 or T282. Shorted: C282.
3	D	Same as step 2.	Defective: 80A8 or 15200. Leaky: C202 or C281. Open: R282. Shorted: R284.	Defective: 80A8 or 15200. Leaky: C202 or C281. Open: R282. Shorted: R284.
4	E	Same as step 1.	No signal — Open: R202. Defective: 1488. Weak or distorted signal — Shorted: C200. Open: R381. Defective: 1486.	No signal — Open: R202. Defective: 1488. Weak or distorted signal — Shorted: C200. Open: R381. Defective: 1486.
5	A	Same as step 1.	No signal — Open: R202. Defective: 1488. Weak or distorted signal — Shorted: C200. Open: R381. Defective: 1486.	No signal — Open: R202. Defective: 1488. Weak or distorted signal — Shorted: C200. Open: R381. Defective: 1486.

Section 3 — I-F, Detector, and A-V-C Circuits

For the tests in this section, use an r-f signal generator, with modulated output; set to 455 kc. Connect the ground lead of the signal generator to B; connect the output lead through a .1-mf. condenser to the test points indicated in the chart. Set the volume control at maximum. If the "NORMAL INDICATION" is obtained in step 1, proceed with the tests for Section 4 (r-f and converter circuits); if not, isolate and correct the trouble within this section.

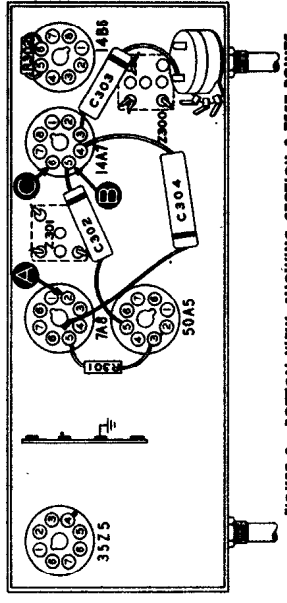

FIGURE 3. BOTTOM VIEW, SHOWING SECTION 3 TEST POINTS

STEP	TEST POINT	NORMAL INDICATION	POSSIBLE CAUSE OF ABNORMAL INDICATION
1	A	Clear signal with weak signal-generator input.	Trouble within this section; isolate by the following tests.
2	C	Same as step 1.	No signal — Open or shorted: 2300. Defective: 1488 or 1487. Open: R301. Shorted: C303. Weak or distorted signal — Leaky: C383. Open: C382 or C384. Defective: 1488 or 1487. Miscellaneous: Z300. Leaky or open: C302.
3	A	Same as step 1.	No signal — Open or shorted: Z381. Weak or distorted signal — Miscellaneous: Z301.

Section 4 — R-F and Converter Circuits

For the tests in this section, use an r-f signal generator, with modulated output. Connect the generator ground lead to B; connect the output lead through a .1-mf. condenser to the test points indicated in the chart.

Inspect the tuning condensers for bent plates, dirt, or poor wiper contacts; any or all of these will cause noise. If the "NORMAL INDICATION" is not obtained in step 1, isolate the trouble by following the remaining steps.

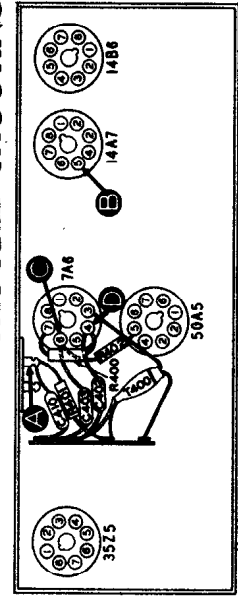

FIGURE 4. BOTTOM VIEW, SHOWING SECTION 4 TEST POINTS

STEP	TEST POINT	DIAL SETTINGS		NORMAL INDICATION	POSSIBLE CAUSE OF ABNORMAL INDICATION
		SIG. GEN.	RADIO		
1	A	540 kc.	840 kc.	Clear signal with weak signal-generator input.	Trouble within this section; isolate by the following tests.
2	D (Occ. test; see note below.)		840 to 1820 kc.	Measure 9 to 12 volts.	Open or shorted: T400, C482, or R400. Shorted: C488 or C400B. Defective: 7A8.
3	C	848 kc.	548 kc.	Same as step 1.	No signal — Open or shorted: Z391. Shorted: C402 or C402A. Defective: 7A8. Weak or distorted signal — Shorted or open: L460. Defective: 7A8.
4	A	548 kc.	540 kc.	Same as step 1.	Weak signal — Open: C401.

OSCILLATOR-TEST NOTE: Connect positive lead of a 28,000-ohms-per-volt meter to B; connect prod end of negative lead through a 100,000-ohm isolating resistor to test point D. Proper operation of oscillator is indicated by a negative voltage of 9 to 15 volts through a coil range of tuning condenser.

MANUAL OF 1949 MOST-OFTEN-NEEDED RADIO DIAGRAMS

PHILCO RADIO MODEL 49-602

Section 1—Power Supply

Make the tests for this section with a d-c voltmeter. Connect the negative lead to B— test point B; connect the positive lead to the test points indicated in the chart. The voltage readings given were taken with a 20,000-ohms-per-volt meter at a line voltage of 117 volts, a.c.

Set the volume control to minimum. The battery pack should be replaced when the "A" voltage drops below 5 volts, or the "B" voltage drops below 60 volts.

If the "NORMAL INDICATION" is obtained in step 1, proceed with the tests for Section 2 (audio circuits); if not, isolate and correct the trouble in this section.

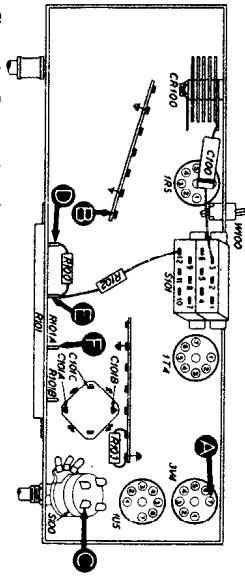

Figure 1. Bottom View, Showing Section 1 Test Points

STEP	TEST POINT	NORMAL INDICATION	ABNORMAL INDICATION	POSSIBLE CAUSE OF ABNORMAL INDICATION
1	A	7.5v	Low voltage	Trouble in this section. Isolate by the following tests.
2	B	80v	No voltage	Defective: C1100. Open: C101A.
3	D	125v	Low voltage	Defective: C1100. Open: S100, S101.
4	E	120v	Low voltage	Changed resistance: R100. Leaky: C101A.
5	F	85v	No voltage	Open: R100. Shorted: C101A.
6	G	7.5v	Low voltage	Changed resistance: R101A. Leaky: C101B.
7	H	7.5v	Low voltage	Open: R101A. Shorted: C101B.
8	I	80v	High voltage	Open: C101B, S101.
9	J	80v	Low voltage	Open: C101B, S101.
10	K	80v	High voltage	Open: R205, R206, S100.
11	L	80v	No voltage	Open: R102, S101. Shorted: C101C.
12	M	80v	High voltage	Open: R102, S101. Shorted: C101C.
13	N	80v	No voltage	Open: R102, S101. Shorted: C101C.
14	O	80v	High voltage	Open: R102, S101. Shorted: C101C.
15	P	80v	No voltage	Open: R102, S101. Shorted: C101C.
16	Q	80v	High voltage	Open: R102, S101. Shorted: C101C.
17	R	80v	No voltage	Open: R102, S101. Shorted: C101C.
18	S	80v	High voltage	Open: R102, S101. Shorted: C101C.
19	T	80v	No voltage	Open: R102, S101. Shorted: C101C.
20	U	80v	High voltage	Open: R102, S101. Shorted: C101C.
21	V	80v	No voltage	Open: R102, S101. Shorted: C101C.
22	W	80v	High voltage	Open: R102, S101. Shorted: C101C.
23	X	80v	No voltage	Open: R102, S101. Shorted: C101C.
24	Y	80v	High voltage	Open: R102, S101. Shorted: C101C.
25	Z	80v	No voltage	Open: R102, S101. Shorted: C101C.

*This part, located in another section, may cause abnormal indication in this section.

TROUBLE SHOOTING

Section 2—Audio Circuits

For the tests in this section, use an audio-frequency signal generator. Connect the generator ground lead to B— test point B; connect the output lead through a .1-mf. condenser to the test points indicated in the chart.

Set the radio volume control to maximum.

If the "NORMAL INDICATION" is obtained in step 1, proceed with the tests for Section 3 (i-f, detector, and a-v-c circuits); if not, isolate and correct the trouble in this section.

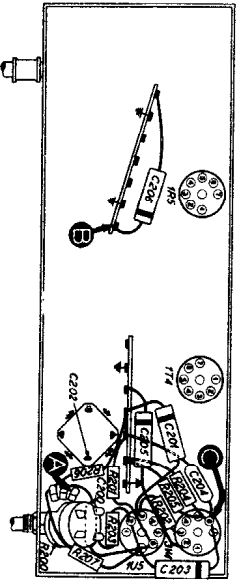

Figure 2. Bottom View, Showing Section 2 Test Points

STEP	TEST POINT	NORMAL INDICATION	POSSIBLE CAUSE OF ABNORMAL INDICATION
1	A	Loud, clear speaker output with moderate generator input.	Trouble in this section. Isolate by the following tests.
2	C	Clear speaker output with strong generator input.	Defective: 374, 1A300. Open: R204, T100. Shorted: C203, C204, C205, T200.
3	A	Same as step 1.	Defective: 115, R200 (internal). Open: C200, R201, R202, R203, C203. Shorted: C201, C201C.*

*This part, located in another section, may cause abnormal indication in this section.

TROUBLE SHOOTING

Section 3—i-f, Detector, And A-V-C Circuits

For the tests in this section, use an i-f signal generator, with modulated output, set at 455 kc. Connect the generator ground lead to B— test point B; connect the output lead through a .1-mf. condenser to the test points indicated in the chart.

Set the radio volume control to maximum.

If the "NORMAL INDICATION" is obtained in step 1, proceed with the tests for Section 4 (r-f and converter circuits); if not, isolate and correct the trouble in this section.

To provide a complete i-f amplifier check, test point A for this section is placed at the grid of the mixer in Section 4; therefore, the effectiveness of step 1 as a master check is dependent upon the condition of certain parts in the mixer circuit. These parts are listed below under "POSSIBLE CAUSE OF ABNORMAL INDICATION."

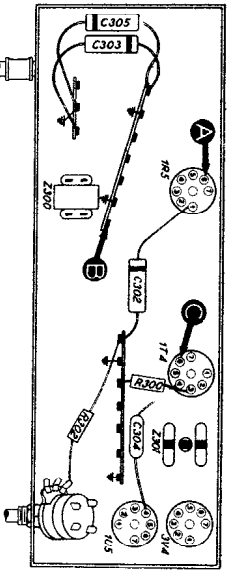

Figure 3. Bottom View, Showing Section 3 Test Points

STEP	TEST POINT	NORMAL INDICATION	POSSIBLE CAUSE OF ABNORMAL INDICATION
1	A	Loud, clear speaker output with weak generator input.	Trouble in this section. Isolate by the following tests.
2	C	Loud, clear output with moderate input.	Defective: 174, 175 (diode section). Misaligned: 2301. Open: R303, C303, L301A, R301, L301B, C301A. Shorted: C300B, C303, L301A, L301B, C301A, C301B.
3	A	Same as step 1.	Defective: 115*, Misaligned: 2300. Open: C300A, L303A, L300A, C300B, T400*. Shorted: C400A*, C400B*, C300A, L300A, L303B, C303B.

*This part, located in another section, may cause abnormal indication in this section.

TROUBLE SHOOTING

Section 4—R-F And Converter Circuits

For the tests in this section, with the exception of the oscillator test, use an i-f signal generator with modulated output. Connect the generator ground lead to B— test point B; connect the output lead through a .1-mf. condenser to the test points indicated in the chart.

Set the radio volume control to maximum. Set the tuning control and signal-generator frequency as indicated in the chart.

If the "NORMAL INDICATION" is obtained in step 1, further tests should be unnecessary; if not, isolate and correct the trouble in this section. If the trouble is not revealed by the tests for this section, check the alignment.

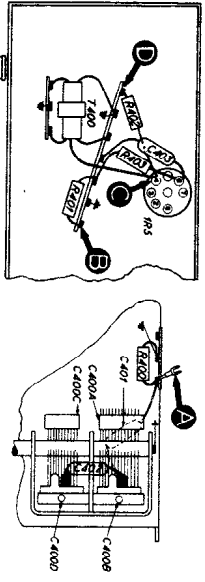

Figure 4. Bottom View, Showing Section 4 Test Points

STEP	TEST POINT	SIGNAL GEN. FREQUENCY	RADIO TUNING	NORMAL INDICATION	POSSIBLE CAUSE OF ABNORMAL INDICATION
1	A	1000 kc.	Tune to signal.	Loud, clear speaker output with weak generator input.	Trouble in this section. Isolate by the following tests.
2	C to D (Osc. lead; see note below)		Rotate through range.	Negative 5 to 10 volts.	Defective: 115. Open: R402, T400. Shorted: C402, C400C, C400D.
3	A	1000 kc.	Tune to signal.	Same as step 1.	Open: C401, C403, R401, R403, T4400.

OSCILLATOR TEST: Connect the positive lead of a high-resistance voltmeter to test point D; connect the prod end of the negative lead through a 100,000-ohm isolating resistor to the oscillator grid (pin 4 of the 1R5), test point C. Use a suitable meter range, such as 0—10 volts. Proper operation of the oscillator is indicated by negative voltage within the range given in the chart (measured with a 20,000-ohms-per-volt meter) throughout the tuning range.

OSCILLATOR TEST: Connect the positive lead of a high-resistance voltmeter to test point D; connect the prod end of the negative lead through a 100,000-ohm isolating resistor to the oscillator grid (pin 4 of the 1R5). Test point C. Use a suitable meter range, such as 0-10 volts. Proper operation of the oscillator is indicated by negative voltage within the range given in the chart (measured with a 20,000-ohms-per-volt meter) throughout the tuning range.

SECTION 4 - RF AND CONVERTER CIRCUITS

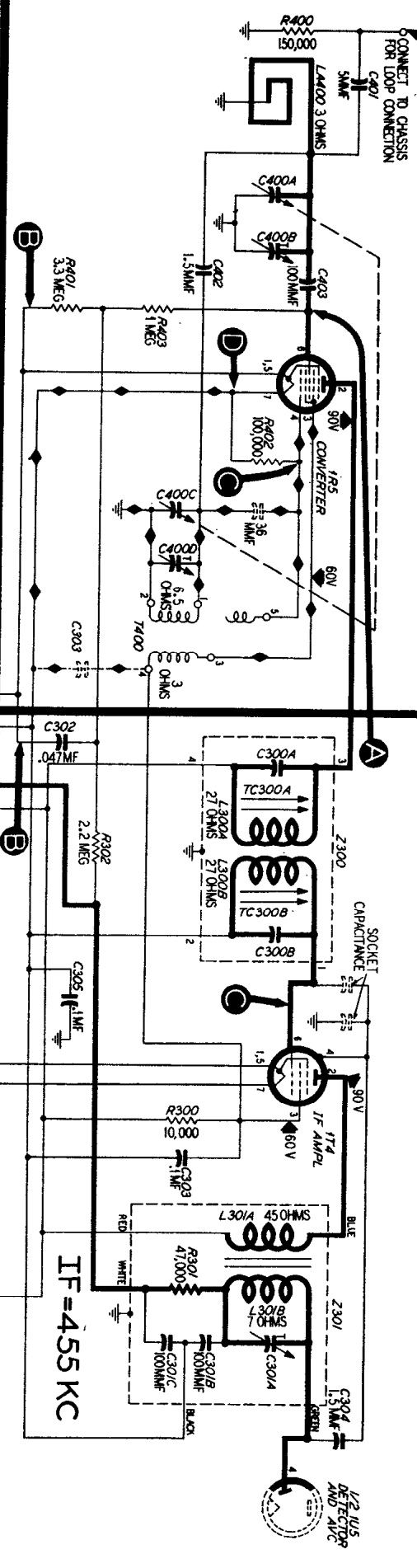

SECTION 3 - IF, DETECTOR AND AVC CIRCUITS

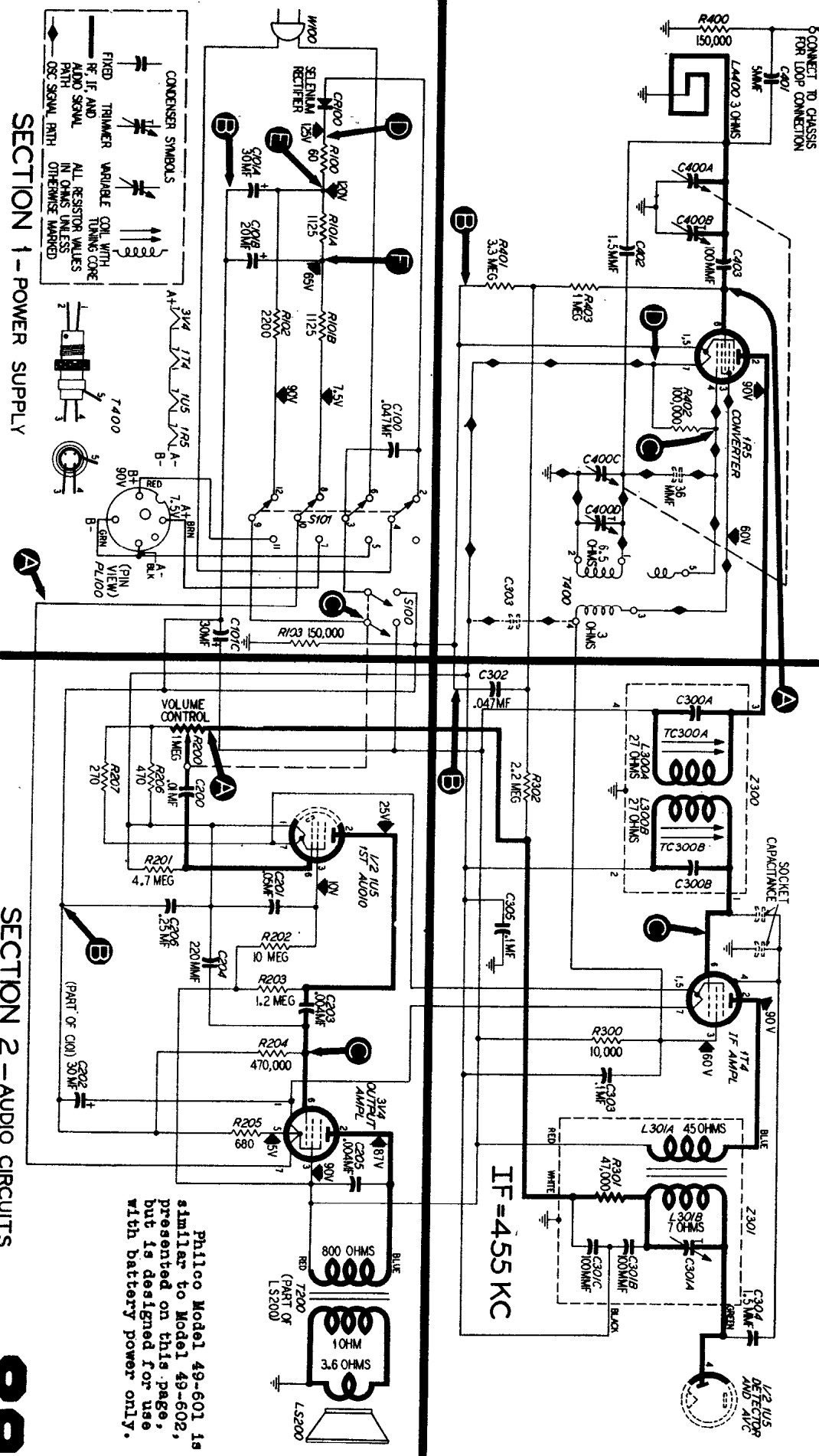

SECTION 2 - AUDIO CIRCUITS

Philco Model 49-402, Sectionalized Schematic Diagram, Showing Test Points

SECTION 1 - POWER SUPPLY

Philco Model 49-601 is similar to Model 49-602, presented on this page, but is designed for use with battery power only.

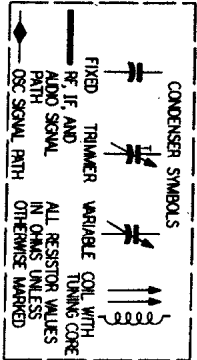

SECTION 4 - RF AND CONVERTER

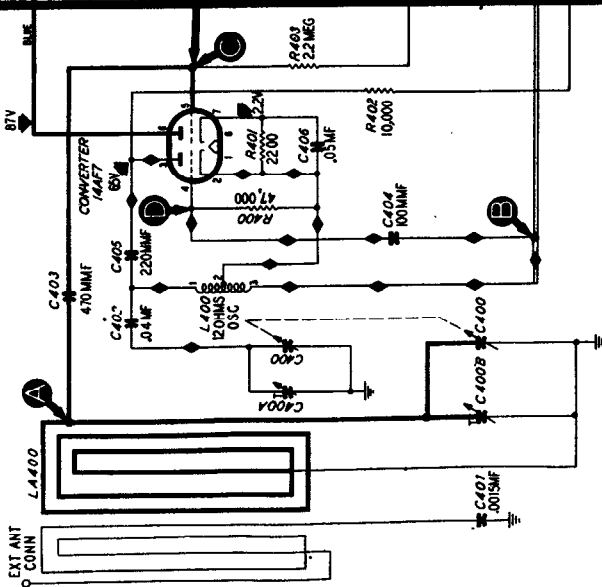

SECTION 3 - IF, DETECTOR, AND AVC

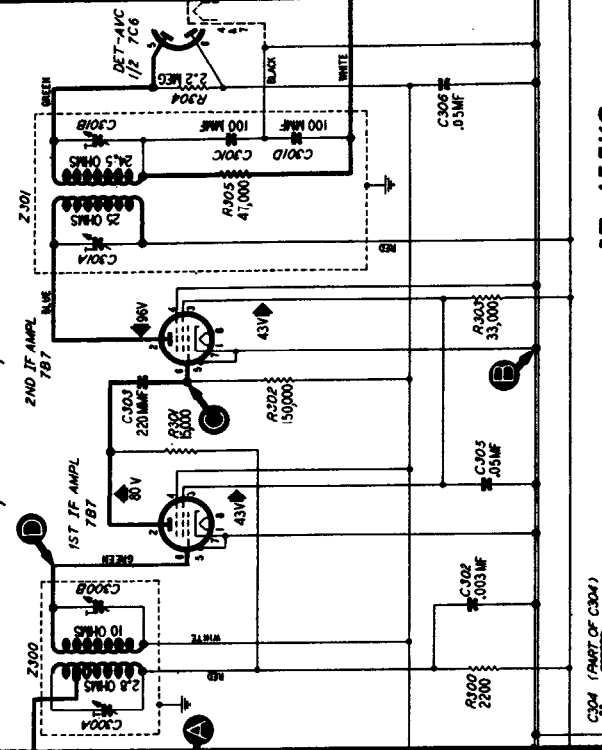

SECTION 2 - AUDIO

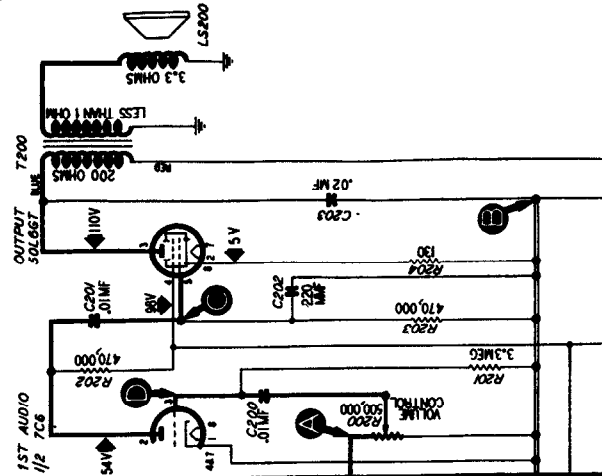

IF-455KC

MODELS 49-900-E AND 49-900-I

VOLTAGES WERE MEASURED BETWEEN THE POINTS INDICATED AND B-USING A 20,000-OHMS-PER-VOLT METER WITH AN INPUT OF 117V A.C.

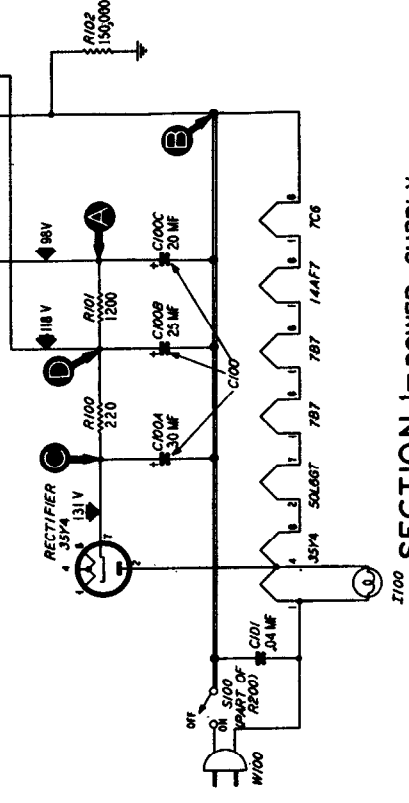
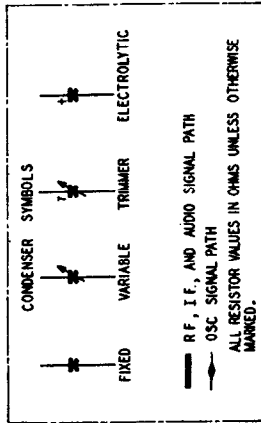

SECTION 1 - POWER SUPPLY

PHILCO RADIO, MODELS 49-900-E AND 49-900-I, SECTIONALIZED SCHEMATIC DIAGRAM, SHOWING TEST POINTS

MANUAL OF 1949 MOST-OFTEN-NEEDED RADIO DIAGRAMS

MODELS 49-900-E AND 49-900-1

PHILCO RADIO

MODELS 49-900-E AND 49-900-1

Section 1 TROUBLE SHOOTING

For the tests in this section, use a d-c voltmeter. Connect the negative lead to the B- bus, test point B; connect the positive lead to the test points indicated in the chart. The voltage readings given were taken with a 20,000-ohm-per-volt meter, at a line voltage of 117 volts, a.c.

Turn the power switch "on," and set the volume control to minimum.

If the "NORMAL INDICATION" is obtained in step 1, proceed with the tests for Section 2; if not, isolate and correct the trouble in this section.

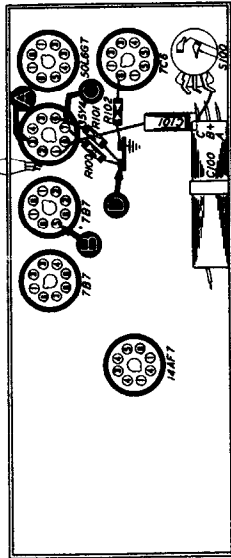

FIGURE 1. BOTTOM VIEW, SHOWING SECTION 1 TEST POINTS

STEP	TEST POINT	NORMAL INDICATION	ABNORMAL INDICATION	POSSIBLE CAUSE OF ABNORMAL INDICATION
1	A	88 volts	No voltage.	Trouble within this section. Isolate by the following tests.
2	C	131 volts	Low voltage. High voltage.	Defective: 317A, W100, R100. Shorted: C100A. Defective: 317A. Open: C100A, 1100. Leaky: C100A. Open: R100.
3	D	110 volts	No voltage. Low voltage. High voltage.	Shorted: C100B. Leaky: C100B, C100C, C208*. Open: R101, R208*, R304*.
4	A	63 volts	No voltage. Low voltage. High voltage.	Shorted: C100C. Open: R101. Leaky: C100C. Open: R304*.

Listening Test: Abnormal hum may be caused by open C100A, C100B, C100C, or R102.

* This part, located in another section, may cause abnormal indication in this section.

Section 2 TROUBLE SHOOTING

For the tests in this section, use an audio-frequency signal generator. Connect the generator ground lead to B- test point B; connect the output lead through a .1-mf. condenser to the test points indicated in the chart.

Set the radio volume control to maximum. Adjust the signal-generator output as required for each step.

If the "NORMAL INDICATION" is obtained in step 1, proceed with the tests for Section 3. If not, isolate and correct the trouble in this section.

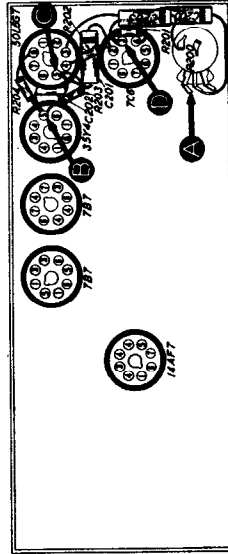

FIGURE 2. BOTTOM VIEW, SHOWING SECTION 2 TEST POINTS

STEP	TEST POINT	NORMAL INDICATION	POSSIBLE CAUSE OF ABNORMAL INDICATION
1	A	Load, clear signal with weak signal input.	Trouble within this section. Isolate by the following tests.
2	C	Clear signal with strong signal input.	Defective: 50A2CT, T100, L3000. Shorted or leaky: C201, C200. Open: R204, R205.
3	D	Same as step 1.	Defective: 7C3. Shorted or leaky: C201. Open: R201, R202, C301.
4	A	Same as step 1. Note: Rotate R205 through range.	Defective: R202. Shorted or leaky: C300. Open: R201, C200.

Listening Test: Distortion on strong signals may be caused by leaky C203 or open R101.

Section 3 TROUBLE SHOOTING

For the tests in this section, use an r-f signal generator, with modulated output, set at 455 kc. Connect the generator ground lead to B-, test point B; connect the output lead through a .1-mf. condenser to the test points indicated in the chart.

Set the radio volume control to maximum.

If the "NORMAL INDICATION" is obtained in step 1, proceed with the tests for Section 4; if not, isolate and correct the trouble in this section.

Since the circuit location of test point A for this section is the same as that of test point C for Section 4, the effectiveness of step 1 as a master check is dependent upon the condition of certain parts in Section 4; these parts are listed under "POSSIBLE CAUSE OF ABNORMAL INDICATION."

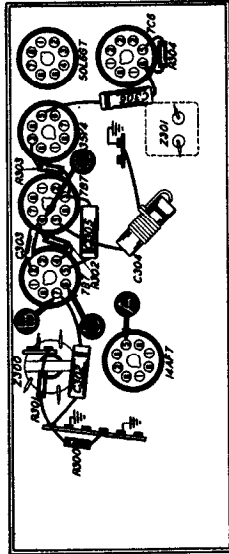

FIGURE 3. BOTTOM VIEW, SHOWING SECTION 3 TEST POINTS

STEP	TEST POINT	NORMAL INDICATION	POSSIBLE CAUSE OF ABNORMAL INDICATION
1	A	Load, clear signal with weak signal input.	Trouble within this section. Isolate by the following tests.
2	C	Load, clear signal with strong signal input.	Defective: 7B7 (bad LL 7C3 (diode section), Z301. Shorted or leaky: C304. Open: R304. Misadjusted: Z301.
3	D	Load, clear signal with moderate signal input.	Defective: 7B7 (1st L4). Shorted or leaky: C302, C302, C302. Open: R301, R300, R300, C302, C302.
4	A	Load, clear signal with weak signal input.	Defective: 1A47*. Z300. Open: R401*, R401*, C406. Shorted or leaky: C304. Misadjusted: Z300.

* This part, located in another section, may cause abnormal indication in this section.

Section 4 TROUBLE SHOOTING

For the tests in this section, use an r-f signal generator, with modulated output. Connect the generator ground lead to B-, test point B; connect the output lead through a .1-mf. condenser to the test points indicated in the chart.

Set the radio volume control to maximum.

If the "NORMAL INDICATION" is not obtained in step 1, isolate the trouble by following the remaining steps.

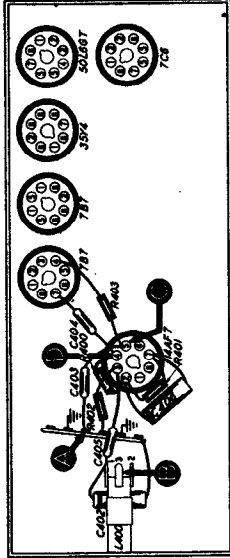
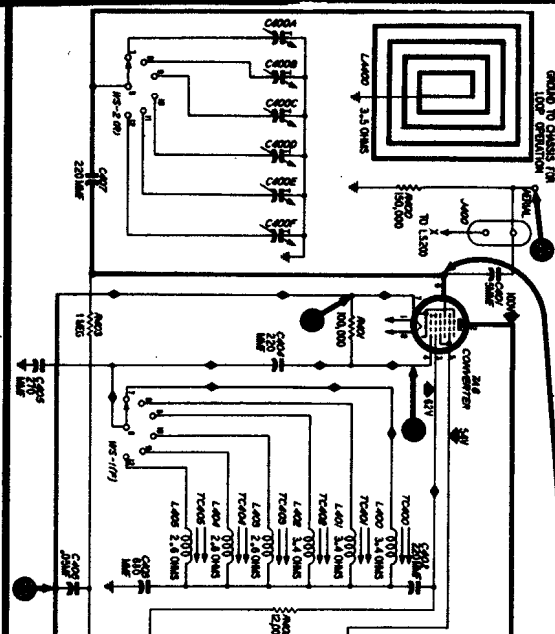

FIGURE 4. BOTTOM VIEW, SHOWING SECTION 4 TEST POINTS (LOCATION OF C401 SHOWN IN FIGURE 4)

STEP	TEST POINT	DIAL SETTINGS		NORMAL INDICATION	POSSIBLE CAUSE OF ABNORMAL INDICATION
		SEG. GRD.	RADIO		
1	A	540 kc.	540 kc.	Load, clear signal with weak signal input.	Trouble within this section. Isolate by the following tests.
2	C	540 kc.	540 kc.	Same as step 1.	Defective: 1A47*. Open: C406, R402. Trouble in oscillator circuit. See step 3.
3	D	(See note below.)	540 kc. 1800 kc.	Negative voltage 1.4 volts to 1.8 volts.	Defective: 1A00. Open: R400, R402, C408, C408. Shorted: C402, C408, C408, C408A.
4	A	540 kc.	540 kc.	Same as step 1.	Defective: L1400, C408, C408B. Open or shorted: C408.

OSCILLATOR TEST: Connect positive lead of a high-resistance voltmeter to B-, test point B; connect prod end of negative lead through a 100,000-ohm isolating resistor to 1A47 oscillator grid. Use a suitable range, such as 0-10 volts. Proper operation of oscillator is indicated by negative voltage of 1.6v to 1.8v (measured with 20,000-ohm-per-volt meter) throughout range of tuning condensers.

SECTION 4 - RF AND CONVERTER



SECTION 3 - IF, DETECTOR, AND AVC

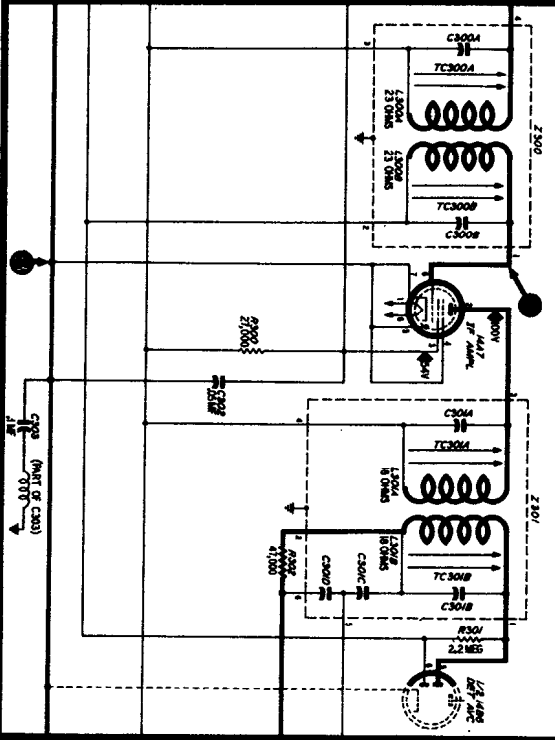

SECTION 2 - AUDIO

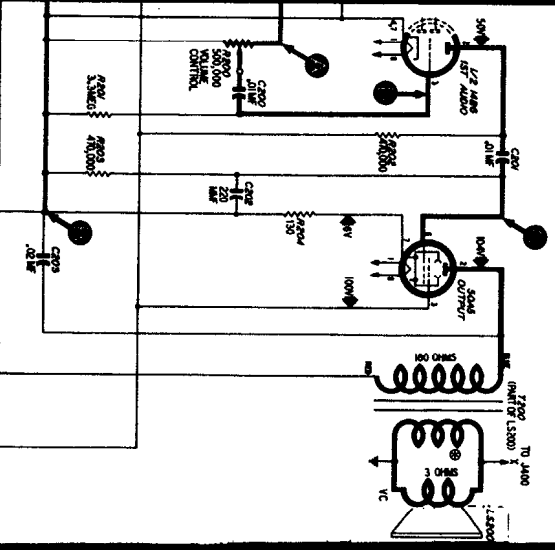

INSTRUCTIONS FOR REMOVING OSCILLATOR COILS

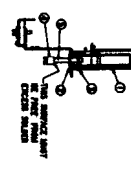

- THE FOLLOWING PROCEDURE IS RECOMMENDED FOR REMOVING THE OSCILLATOR COILS:
1. REMOVE ALL WIRE CONNECTIONS AND FIBERS WELDED FROM COIL.
 2. AND REMOVE COILS BY USING SOLDERING IRON.
 3. REMOVE CLIP (IF COIL SHOULD THEN BE REWORKED).
- REWORK PROCEDURE FOR REMOVING COILS: WHEN REMOVING COILS FROM SOCKET, ALL EXCESS SOLDER FROM SOCKET SHOULD BE REMOVED.

MODEL 49-901

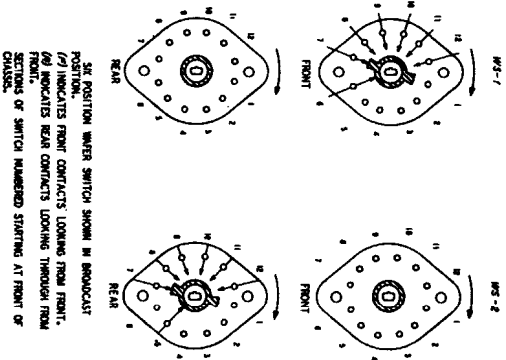
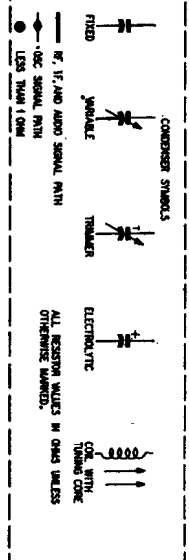

Police Radio Model 49-901, Sectionalized Schematic Diagram, Showing Test Points

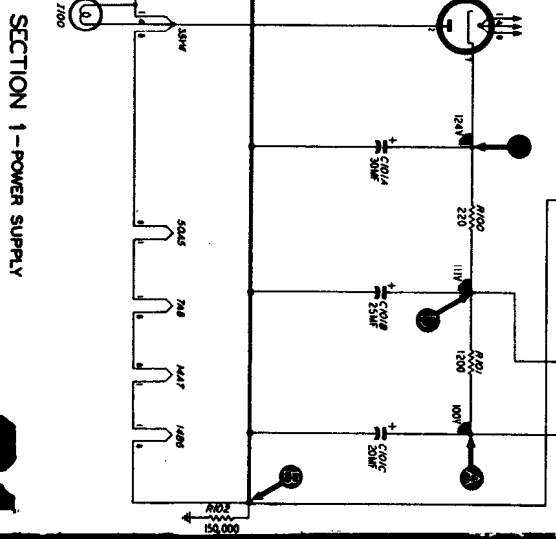

MANUAL OF 1949 MOST-OFTEN-NEEDED RADIO DIAGRAMS

MODEL 49-901

PHILCO RADIO

MODEL 49-901

TROUBLE SHOOTING

Section 1

Power Supply

For the tests in this section, use a d-c voltmeter. Connect the negative lead to B—, test point B; connect the positive lead to the test points indicated in the chart. The voltage readings given were taken with a 20,000-ohm-per-volt meter at a line voltage of 117 volts, a.c.

Turn on the power, and set the volume to minimum.

If the "NORMAL INDICATION" is obtained in step 1, proceed with the tests for Section 2 (audio circuits); if not, isolate and correct the trouble in this section.

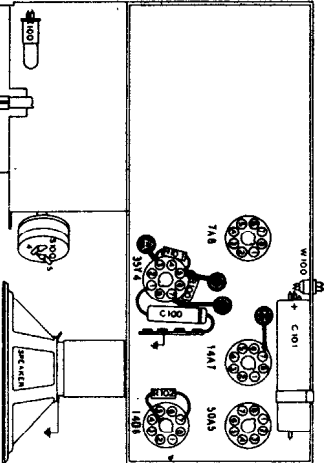

Figure 1. Bottom View, Showing Section 1 Test Points

STEP	TEST POINT	NORMAL INDICATION	ABNORMAL INDICATION	POSSIBLE CAUSE OF ABNORMAL INDICATION
1	A	100 volts	No voltage	Trouble within this section. Isolate by the following tests:
2	C	124 volts	Low voltage	Defective: 537A. Open: W100, S100. Shorted: C101A.
3	D	111 volts	Low voltage	Leaky: C101A. Open: C101A.
			High voltage	Open: R100.
			No voltage	Leaky: C101A, C101B. Shorted: C203*.
4	A	100 volts	High voltage	Open: R101, T200*, R204*.
			Low voltage	Shorted: C101C. Open: R101.
			No voltage	Leaky: C101C.

* This part, located in another section, may cause abnormal indication in this section.

Section 2

Audio Circuits

For the tests in this section, use an audio-frequency signal generator. Connect the generator ground lead to B—, test point B; connect the output lead through a .1-mf. condenser to the test points indicated in the chart.

Set the volume to maximum.

If the "NORMAL INDICATION" is obtained in step 1, proceed with the tests for Section 3 (I-F, detector, and A-V-C circuits); if not, isolate and correct the trouble in this section.

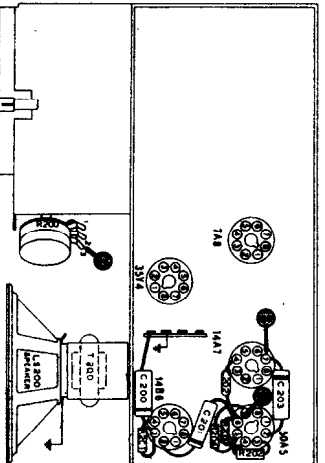

Figure 2. Bottom View, Showing Section 2 Test Points

STEP	TEST POINT	NORMAL INDICATION	POSSIBLE CAUSE OF ABNORMAL INDICATION
1	A	Load, clear speaker output with moderate signal-generator input.	Trouble within this section. Isolate by the following tests:
3	C	Load, clear output with strong input.	Defective: 3A45, 1S901. Shorted: C202, C201, C300. Open: T200, R204.
3	D	Load, clear output with moderate input.	Defective: 148B. Open: R202, R201, C201.
4	A	Same as step 3.	Shorted: C200, C301D*. Open: C200, R200 (probe through range).

* This part, located in another section, may cause abnormal indication in this section.

TROUBLE SHOOTING

Section 3

I-F, Detector, and A-V-C Circuits

For the tests in this section, use an i-f signal generator, with modulated output, set at 455 kc. Connect the generator ground lead to B—, test point B; connect the output lead through a .1-mf. condenser to the test points indicated in the chart.

Set the volume to maximum.

If the "NORMAL INDICATION" is obtained in step 1, proceed with the tests for Section 4 (r-f and converter circuits); if not, isolate and correct the trouble in this section.

To provide a complete i-f-amplifier check, test point A for this section is placed at the grid of the mixer in Section 4; therefore, the effectiveness of step 1 as a master check is dependent upon the condition of certain parts in the mixer circuit. These parts are listed below under "POSSIBLE CAUSE OF ABNORMAL INDICATION."

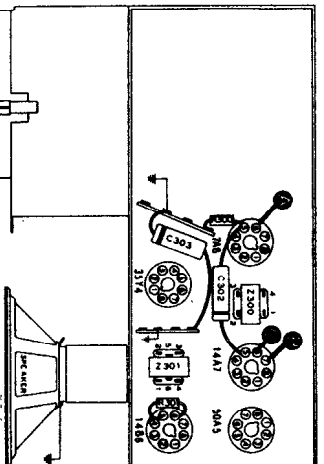

Figure 3. Bottom View, Showing Section 3 Test Points

STEP	TEST POINT	NORMAL INDICATION	POSSIBLE CAUSE OF ABNORMAL INDICATION
1	A	Load, clear speaker output with moderate signal-generator input.	Trouble within this section. Isolate by the following tests:
3	C	Load, clear output with moderate input.	Defective: 1A7, 1AB6 (diode section). Shorted: C302, Z301. Open: Z301, R300, R201, R302. Malaligned: Z301.
3	A	Same as step 2.	Defective: 7AS*. Shorted: Z300. Open: Z300. Malaligned: Z300.

* This part, located in another section, may cause abnormal indication in this section.

TROUBLE SHOOTING

Section 4

R-F and Converter Circuits

For the tests in this section, with the exception of the oscillator test, use an i-f signal generator with modulated output. Connect the generator ground lead to B—, test point B; connect the output lead through a .1-mf. condenser to the test points indicated in the chart.

Set the volume to maximum, and set the drum tuner and the signal-generator frequency as indicated in the chart.

If the "NORMAL INDICATION" is not obtained in step 1, isolate and correct the trouble in this section. If the trouble is not revealed by the tests for this section, check the alignment.

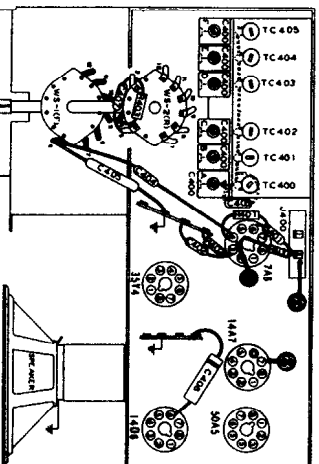
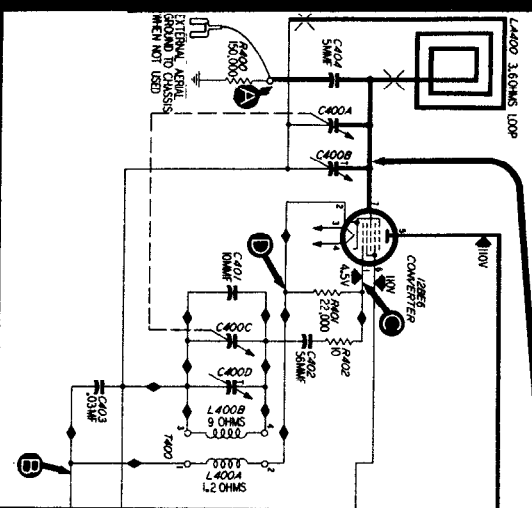

Figure 4. Bottom View, Showing Section 4 Test Points

STEP	TEST POINT	sig. gen. freq.	DUMM TUNER	NORMAL INDICATION	POSSIBLE CAUSE OF ABNORMAL INDICATION
1	A	Adjust to frequency of each tuner for each station setting.	De-tune drum tuner, in increments of 100 kc. (1000 kc. per turn).	Load, clear speaker output with signal-generator input.	Trouble in circuit associated with each point of the station-selector drum tuner, isolate by steps 2 and 3.
2	C to B (see Note below)	Same as step 1.	Same as step 1.	-35° to -45°.	No voltage for any station setting—Defective: 7AB. Shorted: C402, C403, C404, C405, L400 to L405, WS1(F). Open: L400 to L405, C404, C403, R401.
3	A	Same as step 1.	Same as step 1.	Same as step 1.	Shorted: C407, WS2(F), C402A-F. Open: C403, C404, R403, WS2(F), C400A-F.

OSCILLATOR TEST: Connect the positive lead of a high-resistance voltmeter to B—, test point B; connect the grid end of the negative lead through a 180,000-ohm isolating resistor to the oscillator grid (pin 4 of 7AB), test point C. Use a suitable meter range, such as 50,000-ohm-per-volt range. The positive voltage of approximately the value given in the chart (measured with 50,000-ohm-per-volt meter) throughout the tuning range.

SECTION 4
RF AND CONVERTER CIRCUITS



SECTION 3
IF, DETECTOR, AND AVC CIRCUITS

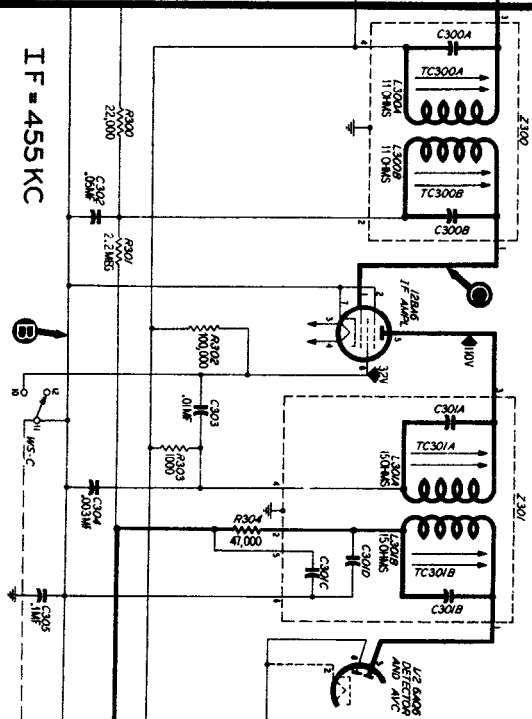

SECTION 2
AUDIO CIRCUITS

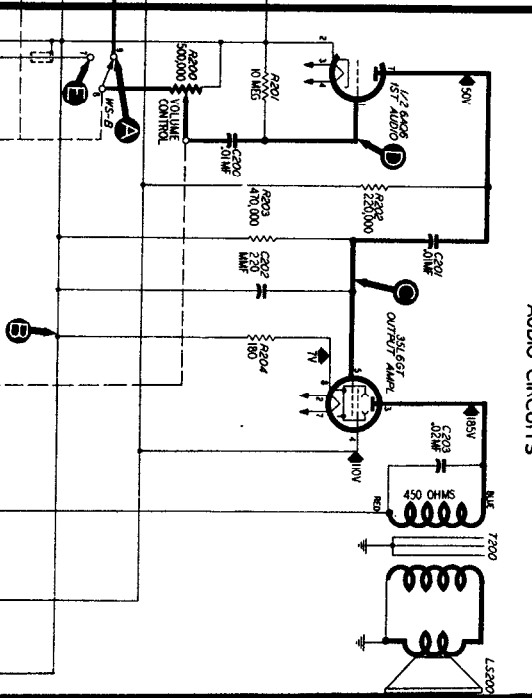

MODEL 49-1401

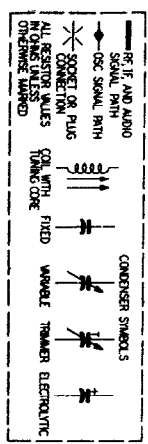
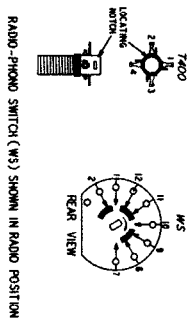

SECTION 1 - POWER SUPPLY

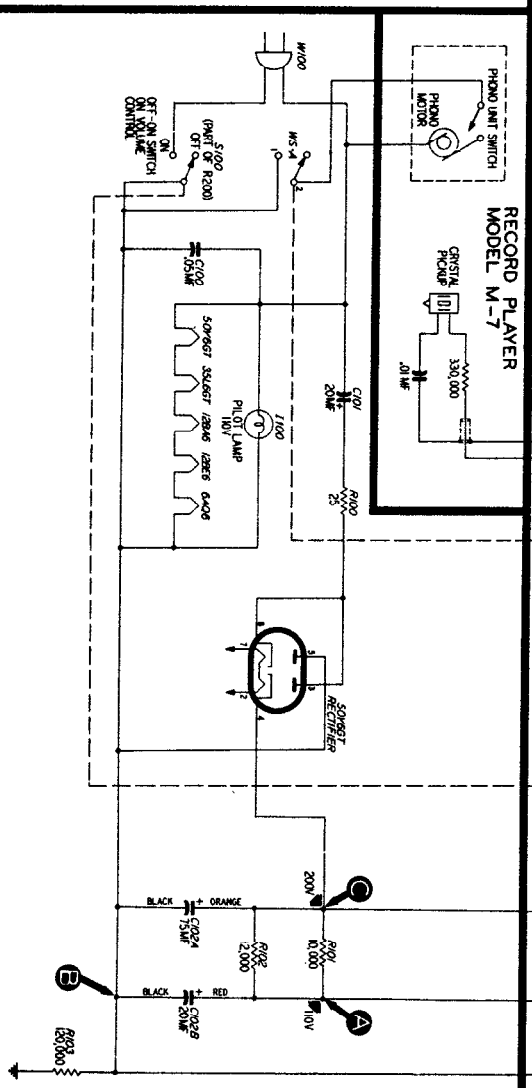

Philco Model 49-1401, Sectionalized Schematic Diagram, Showing Test Points

MANUAL OF 1949 MOST-OFTEN-NEEDED RADIO DIAGRAMS

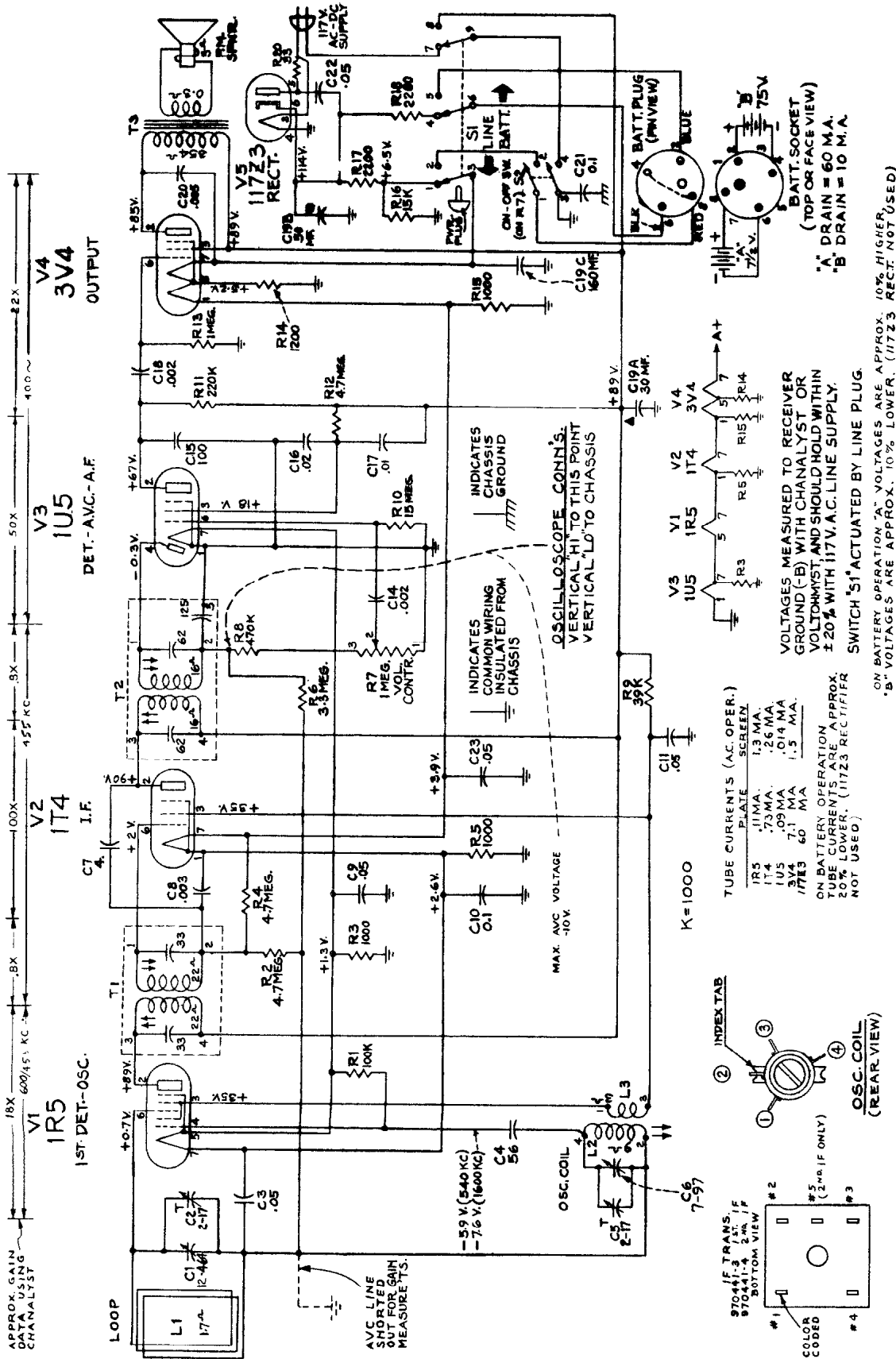

Frequency Range 540-1,600 kc
 Intermediate Frequency 455 kc

MODEL 8BX5
 Chassis No. RC-1059

RCA VICTOR



MANUAL OF 1949 MOST-OFTEN-NEEDED RADIO DIAGRAMS

RCA VICTOR MODEL 8BX6

Chassis No. RC-1040C

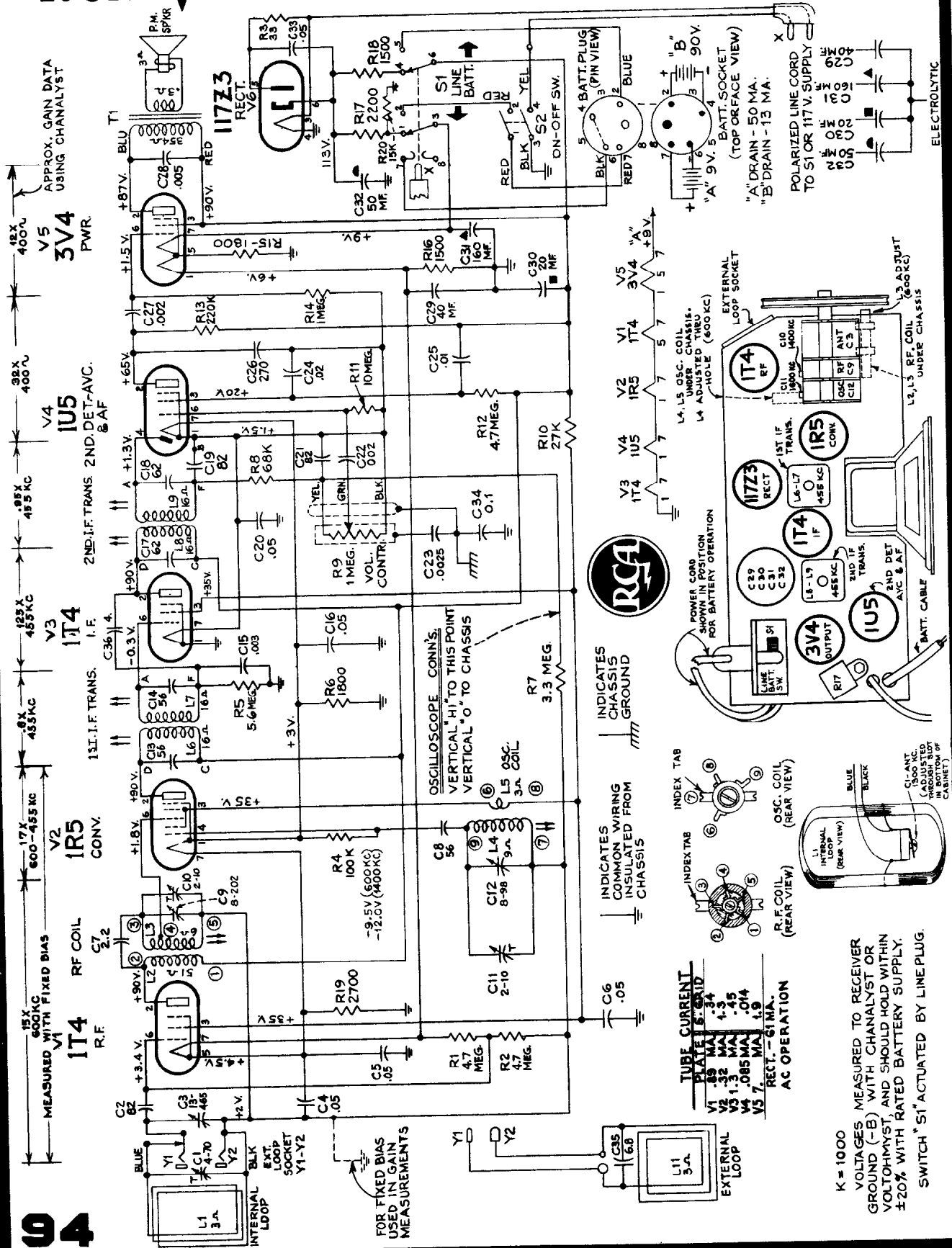

VOLTAGES MEASURED TO RECEIVER GROUND (-B) WITH CHANALYST OR VOLTOHMIST, AND SHOULD HOLD WITHIN ±20% WITH RATED BATTERY SUPPLY.

SWITCH "S1" ACTUATED BY LINE PLUG.

K = 1000

MANUAL OF 1949 MOST-OFTEN-NEEDED RADIO DIAGRAMS

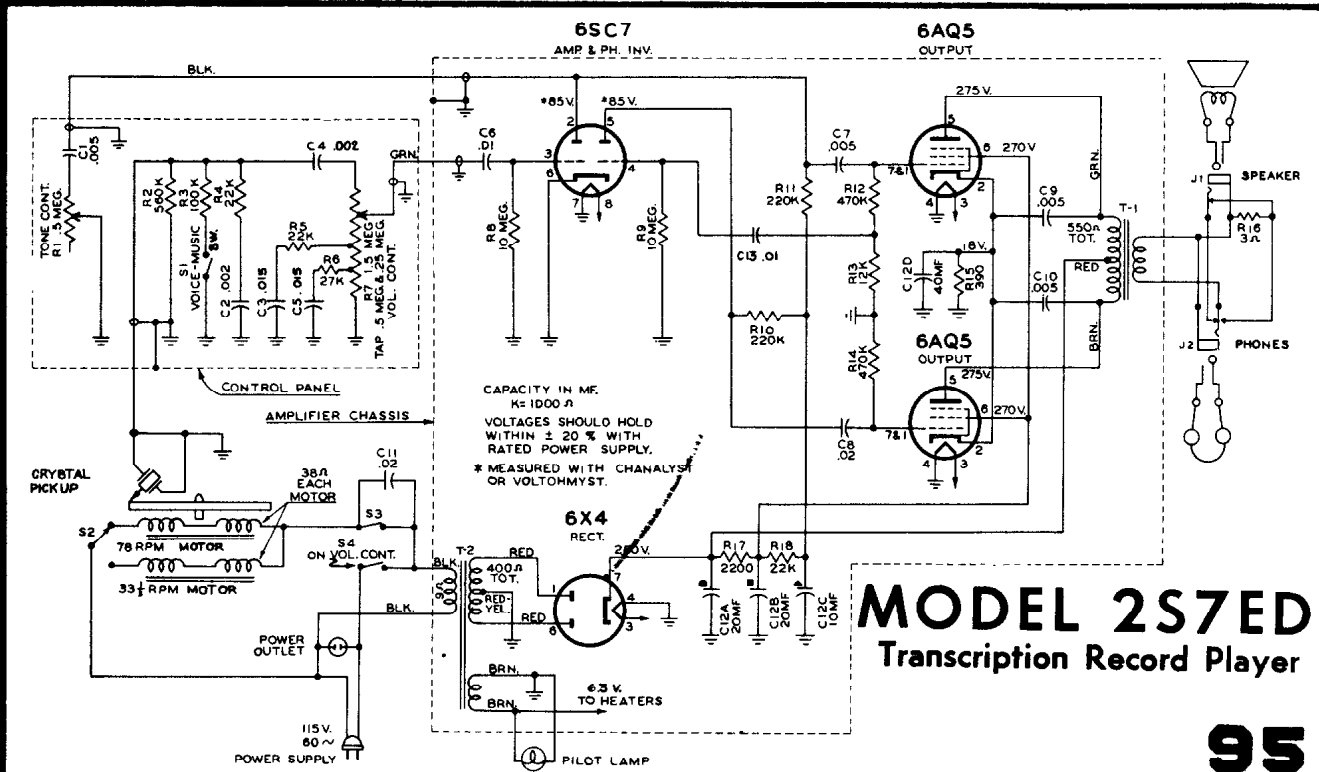
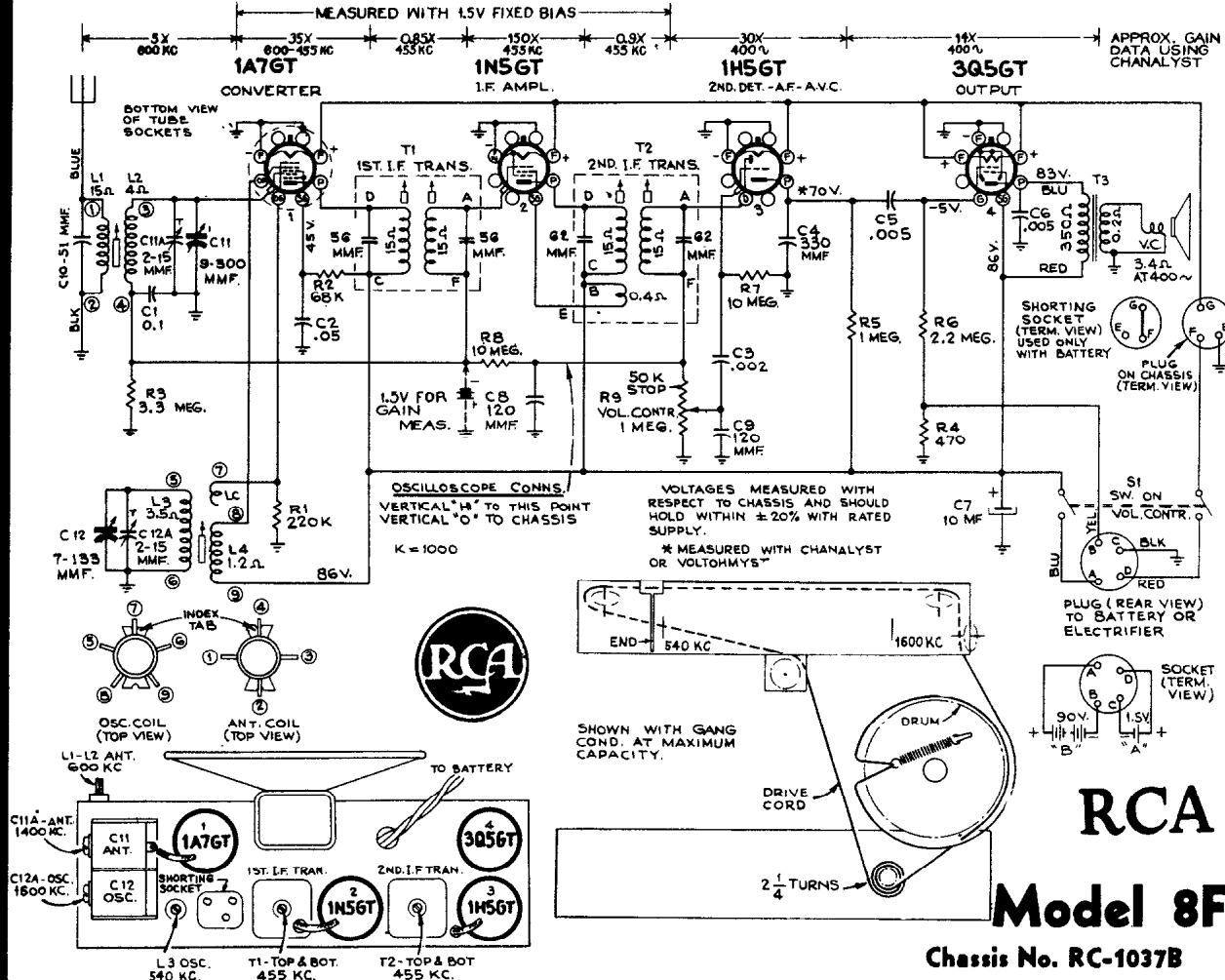

MANUAL OF 1949 MOST-OFTEN-NEEDED RADIO DIAGRAMS

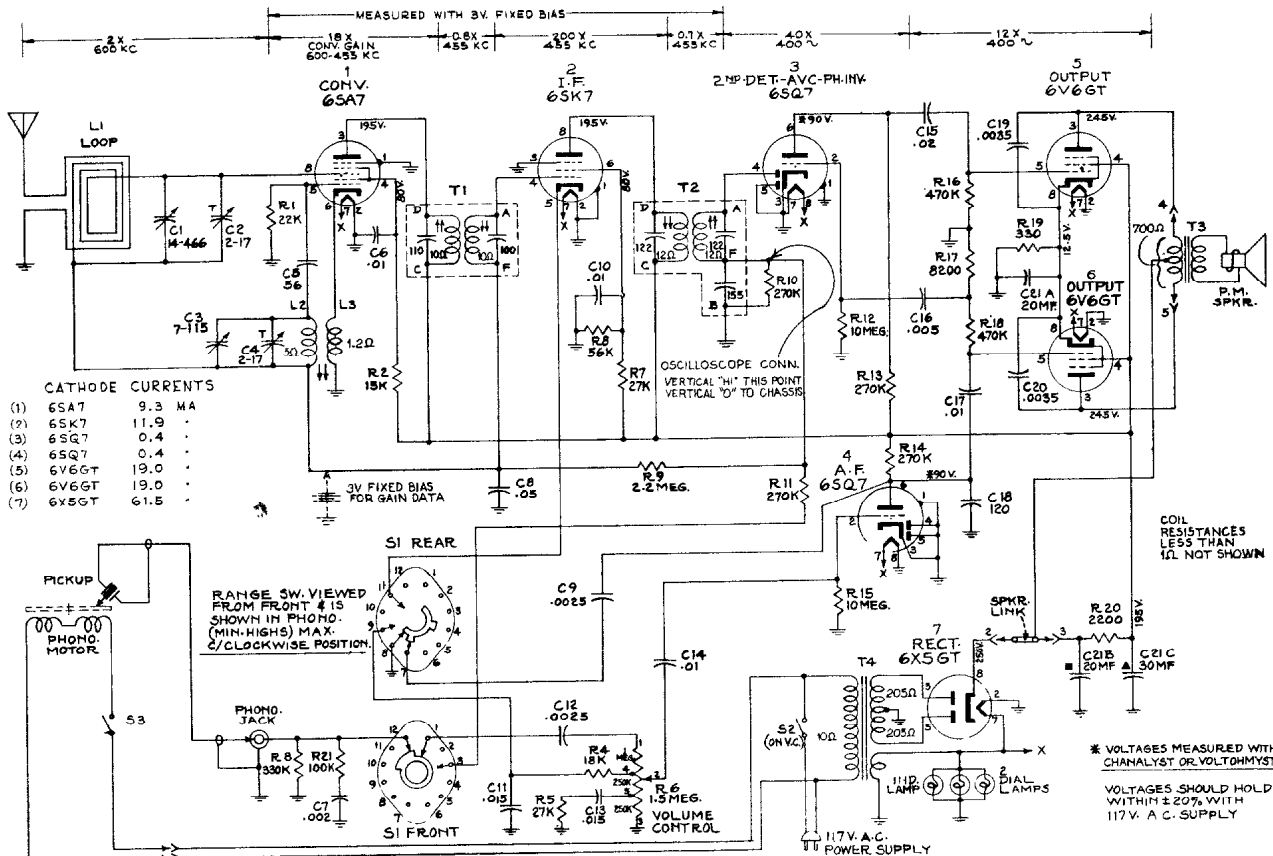

RCA VICTOR MODEL 8V7, 77V1 Chassis No. RC-615 Alignment Procedure

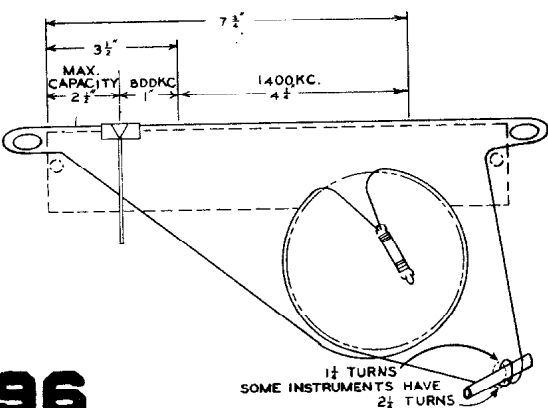
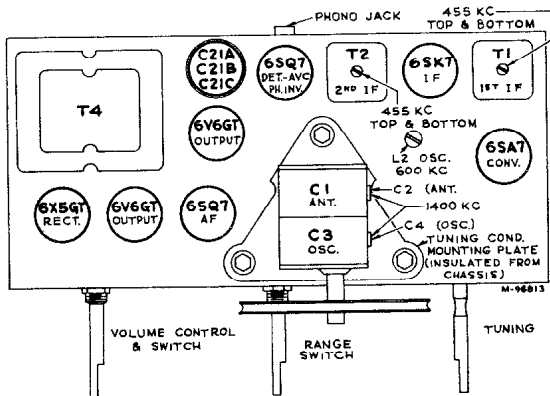

Cathode-Ray Alignment is the preferable method. Connections for the oscilloscope are shown on the Schematic Diagram.

Output Meter Alignment.—If this method is used, connect the meter across the voice coil, and turn the receiver volume control to maximum.

Test Oscillator.—For all alignment operations, connect the low side of the test-oscillator to the receiver chassis, and keep the oscillator output as low as possible to avoid a-v-c action.

Steps	Connect high side of test oscillator to—	Tune test oscillator to—	Turn radio dial to—	Adjust the following for maximum peak output
1	6SK7 grid in series with .01 mfd.	455 kc.	Quiet Point at 550 kc. end of dial	Top and bottom (2nd I-F Trans.) T-2
2	6SA7 grid in series with .01 mfd.			Top and bottom (1st I-F Trans.) T-1
3		1,400 kc.	1,400 kc.	C4 (osc.) C2 (ant.)
4	Primary lead on loop in series with 200 mmfd.	600 kc.	600 kc.	L2 (osc.) Rock gang
5			Repeat steps 3 and 4	

Critical Lead Dress:

1. Dress speaker cable leads down next to chassis.
2. Dress output plate capacitors next to chassis.
3. Dress plate lead of output tube away from grid of audio amplifier.
4. Dress all a-c leads away from volume control down next to chassis.
5. Dress lead from top tap of volume control to range-tone switch along front apron of chassis.
6. Dress R12 and R15 down near chassis base.

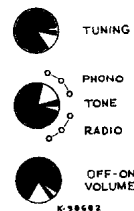

Controls

MANUAL OF 1949 MOST-OFTEN-NEEDED RADIO DIAGRAMS

RCA Victor Models 8R71, 8R74, 8R75, *- 8R72, 8R76

(Alignment on next page) Chassis RC-1060 *- RC-1060A

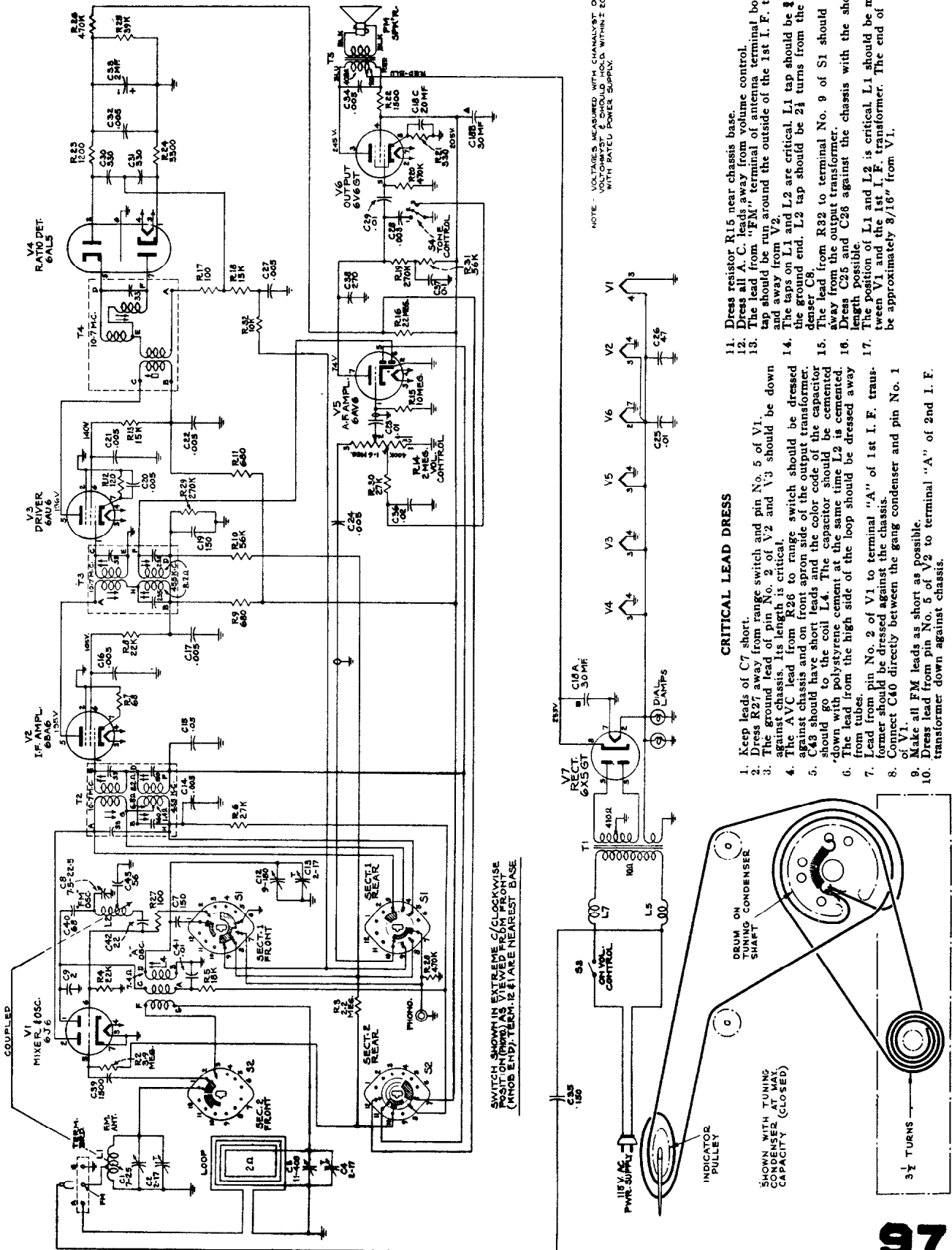

CRITICAL LEAD DRESS

1. Keep leads of C7 short.
2. Dress R27 away from range switch and pin No. 5 of V1.
3. The ground lead of pin No. 2 of V2 and V3 should be down against chassis. Its length is critical.
4. The AVC lead from R26 to range switch should be dressed against chassis and on front apron side of the output transformer.
5. C43 should have short leads and the color code of the capacitor should go to the coil L4. The capacitor should be cemented down with polystyrene cement at the same time L2 is cemented.
6. The lead from the high side of the loop should be dressed away from tubes.
7. Lead from pin No. 2 of V1 to terminal "A" of 1st I. F. transformer should be dressed against the chassis.
8. Connect C40 directly between the gang condenser and pin No. 1 of V1.
9. Make all FM leads as short as possible.
10. Dress lead from pin No. 5 of V2 to terminal "A" of 2nd I. F. transformer down against chassis.

11. Dress resistor R15 near chassis base.
12. Dress all A. C. leads away from volume control.
13. The lead from "FM" terminal of antenna terminal board to L1 tap should be run around the outside of the 1st I. F. transformer and away from V2.
14. The taps on L1 and L2 are critical. L1 tap should be 3 turns from the ground end. L2 tap should be 24 turns from the gang condenser C8.
15. The lead from R32 to terminal No. 9 of S1 should be dressed away from the output transformer.
16. Dress C25 and C26 against the chassis with the shortest lead length possible.
17. The position of L1 and L2 is critical. L1 should be midway between V1 and the 1st I. F. transformer. The end of L2 should be approximately 3/16" from V1.

NOTE - VOLTAIRES MEASURED WITH CHASSIS BASE OR VOLUME CONTROL SHOULD HOLD WITHIN 10% WITH RATED POWER SUPPLY.

MANUAL OF 1949 MOST-OFTEN-NEEDED RADIO DIAGRAMS

RCA VICTOR

8R71, 8R74, 8R75

8R72, 8R76

Chassis No. RC-1060

Chassis No. RC-1060A

Alignment Procedure

**CORRECT ALIGNMENT OF THE FM BAND
REQUIRES THAT THE AM BAND BE
ALIGNED FIRST**

Alignment Indicators:

An RCA VoltOhmyst or equivalent meter is necessary for measuring developed d-c voltage during FM alignment. Connections are specified in the alignment tabulation. An output meter is also necessary to indicate minimum audio output during FM Ratio Detector alignment. Connect the output meter across the speaker voice coil.

The RCA VoltOhmyst can also be used as an AM alignment indicator, either to measure audio output or to measure a-v-c voltage.

When audio output is being measured the volume control should be turned to maximum.

Signal Generator:

For all alignment operations connect the low side of the signal generator to the receiver chassis. The output should be adjusted to provide accurate resonance indication at all times. If output measurement is used for AM alignment the output of the signal generator should be kept as low as possible to avoid a-v-c action.

The FM i-f alignment may be checked by means of an FM sweep generator and cathode ray oscilloscope. Connect the output from the sweep generator, which is set to 10.7 mc., to the mixer grid (6J6 Pin No. 5), low side to chassis. Disconnect the 2 mfd. capacitor C33 from the Ratio Detector circuit.

Connect the high side of the oscilloscope to the junction of R25 and R26, low side to chassis. Adjust the sweep generator and oscilloscope to obtain the response curve.

The Ratio Detector characteristic may be viewed by connecting the oscilloscope across the volume control R14. Capacitor C33 should be re-connected before checking the Ratio Detector characteristic.

AM Alignment

RANGE SWITCH IN BC POSITION

Steps	Connect high side of sig. gen. to—	Sig. gen. output	Turn radio dial to—	Adjust for peak output
1	C3 in series with .01 mfd.	455 kc.	Quiet point at low freq. end.	AM windings.† T3 bottom core (sec.). T3 top core (pri.).
2				AM windings.† T2 top core (sec.). T2 bottom core (pri.).
3	"A" terminal of terminal board at rear of chassis in series with 220 mmf.	1400 kc.	1400 kc.	C13 osc. C4 ant.
4		600 kc.	600 kc.	L4 osc. (Rock gang.)
5	Repeat Steps 3 and 4.			

† Use alternate loading.

Alternate loading involves the use of a 47,000 ohm resistor to load the AM plate winding while the AM grid winding of the SAME TRANSFORMER is being peaked. Then the grid winding is loaded with the resistor while the plate winding is peaked. Only one winding is loaded at any one time. Remove the 47,000 ohm resistor after T3 and T2 have been aligned.

Oscillator frequency is above signal frequency on both AM and FM.

FM Alignment

RANGE SWITCH IN FM POSITION — VOLUME CONTROL MAXIMUM

Steps	Connect high side of sig. gen. to—	Sig. gen. output	Turn radio dial to—	Adjust for peak output
1	Connect the d-c probe of a VoltOhmyst to the negative lead of the 2 mfd. capacitor C33 and the common lead to chassis. Turn gang condenser to max. capacity (fully meshed).			
2	Pin 1 of 6AU6 in series with .01 mfd.	10.7 mc. modulated 30% 400 cycles AM (Approx. .05 volt).	Max. capacity (fully meshed).	T4 top core for max. d-c voltage across C33. T4 bottom core for min. audio output.*
3	FM ant. term. in series with a 300 ohm resistor. (Remove ant. lead from "FM" term.)	10.7 mc. Adjust to provide 2 to 3 volts indication on VoltOhmyst during alignment.		FM windings.†† T3 top core (sec.). T3 bottom core (pri.).
4		106 mc.	106 mc.	FM windings.†† T2 top core (sec.). T2 bottom core (pri.).
5		90 mc.	90 mc.	L2 osc.** C2 ant. Set C2 at max. capacity while adjusting L2.
6				L1 ant.** (Rock gang.)
7	Repeat Steps 5 and 6 until further adjustment does not improve calibration.			

* Two or more points may be found which lower the audio output. At the correct point the minimum audio output is approached rapidly and is much lower than at any incorrect point.

†† Align T3 and T2 by means of alternate loading as explained under AM alignment. Use a 680 ohm resistor instead of a 47,000 ohm resistor and load the FM windings.

** L1 and L2 are adjustable by increasing or decreasing the spacing between turns.

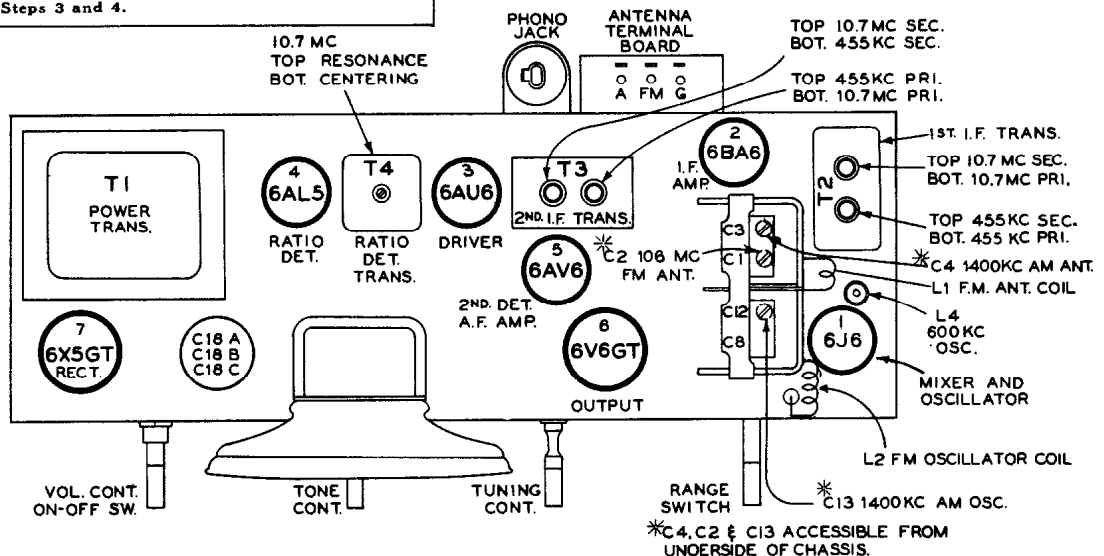

MANUAL OF 1949 MOST-OFTEN-NEEDED RADIO DIAGRAMS

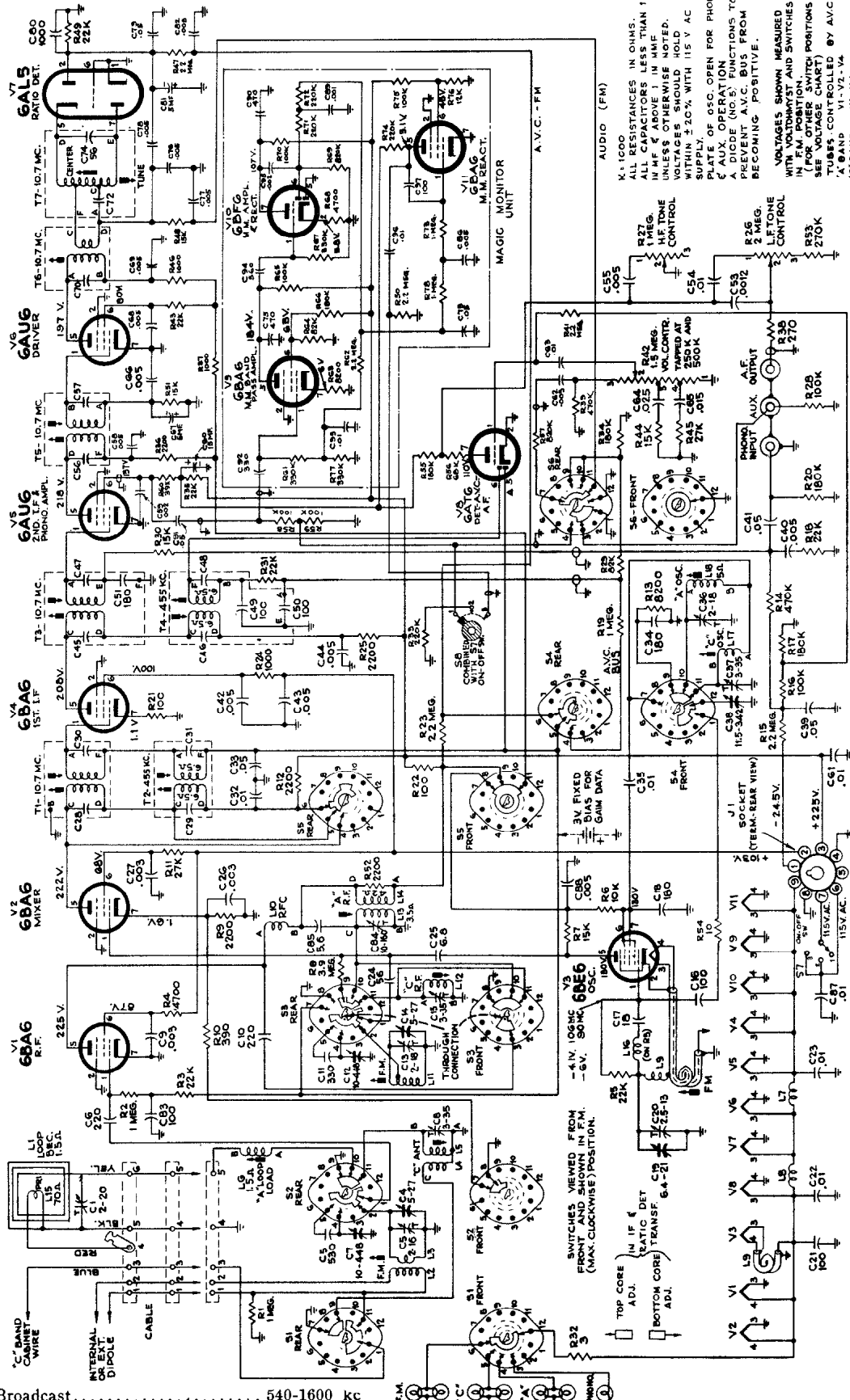

VOLTAGES SHOWN MEASURED WITH VOLTMETER AND SWITCHES IN "ON" POSITION (SEE VOLTAGE CHART) TUBES CONTROLLED BY A.V.C. BAND VI-V2-V4 P-4
VOLTAGES SHOWN MEASURED WITH VOLTMETER AND SWITCHES IN "OFF" POSITION (SEE VOLTAGE CHART) TUBES CONTROLLED BY A.V.C. BAND VI-V2-V4 P-4
VOLTAGES SHOWN MEASURED WITH VOLTMETER AND SWITCHES IN "ON" POSITION (SEE VOLTAGE CHART) TUBES CONTROLLED BY A.V.C. BAND VI-V2-V4 P-4
VOLTAGES SHOWN MEASURED WITH VOLTMETER AND SWITCHES IN "OFF" POSITION (SEE VOLTAGE CHART) TUBES CONTROLLED BY A.V.C. BAND VI-V2-V4 P-4

Continued on the next page.

Model 8V151

RK-121C RF-IF Chassis
RS-123D Power Supply & AF Chassis

Complete Schematic Diagram RK-121C — Range Switch shown in FM position.

RCA VICTOR



Broadcast..... 540-1600 kc
 Shortwave "C" Band..... 9.2-16.0 mc
 Frequency Modulation..... 88-108 mc

MANUAL OF 1949 MOST-OFTEN-NEEDED RADIO DIAGRAMS

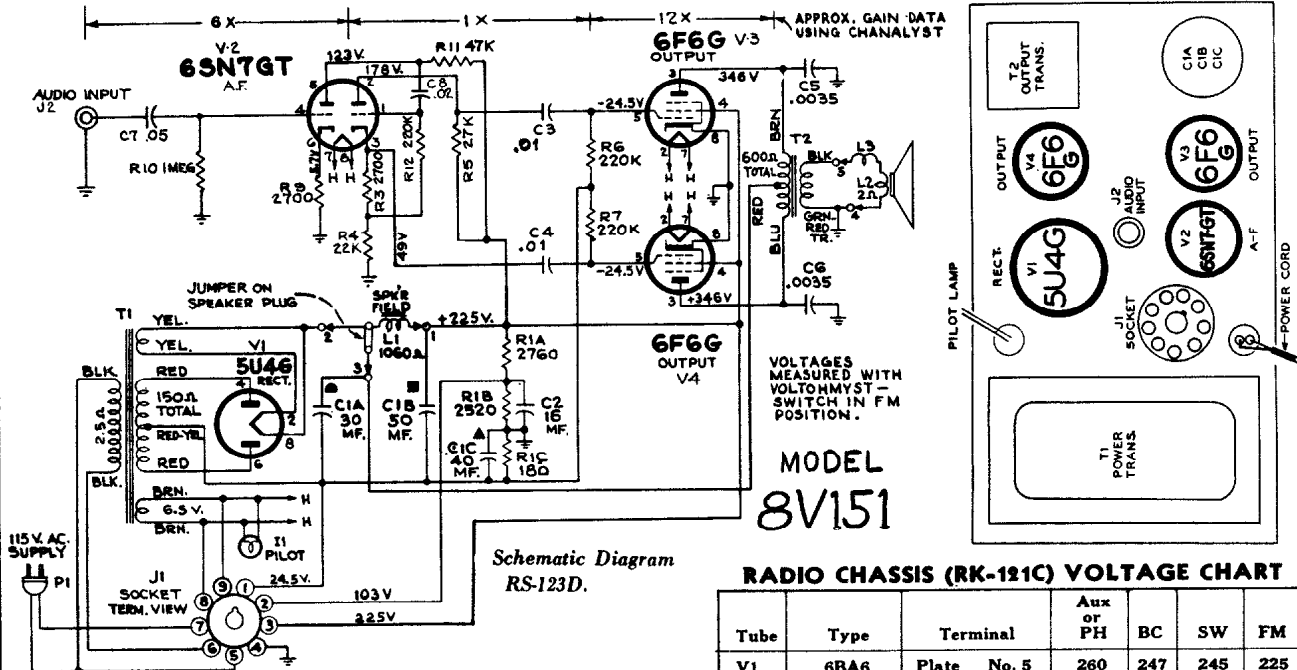

Schematic Diagram RS-123D.

AMPLIFIER (RS123D) VOLTAGE CHART

Tube	Type	Terminal	Aux or PH	BC or SW	FM
V1	5U4G Rect.	Fil. No. 8	360	355	350
V2	6SN7 A. F. & Ph. Inv.	Plate No. 2 Plate No. 5 Cathode No. 3 Cathode No. 6	201 142 56 6.4	190 134 53 6.1	176 123 49 5.7
V3	6F6G Output	Plate No. 3 Screen No. 4 Grid No. 5	353 268 -24	351 245 -24.1	346 225 -24.5
V4	6F6G Output	Same as V3			

RADIO CHASSIS (RK-121C) VOLTAGE CHART

Tube	Type	Terminal	Aux or PH	BC	SW	FM
V1	6BA6 R.F.	Plate No. 5 Screen No. 6	260 100	247 96	245 94	225 87
V2	6BA6 Mixer	Plate No. 5 Screen No. 6 Cathode No. 7	260 96 6.1	245 7 7	240 71 1.9	222 68 1.6
V3	6BE6 Osc.	Plate No. 5 Screen Nos. 6 & 7 *Grid No. 1 †Grid No. 1	160 160 -26 -18	157 157 -11 -10.5	130 130 -4.1 -6
V4	6BA6 1st I.F.	Plate No. 5 Screen No. 6 Cathode No. 7	240 118 1.2	232 110 1.2	225 108 1.2	208 100 1.1
V5	6AU6 2nd I.F.	Plate No. 5 Screen No. 6	.. 115	.. 112	.. 112	218 137
V6	6AU6 Driver	Plate No. 5 Screen No. 6	197 80
V7	6AL5 R. Det.
V8	6AT6 Det.-A.F.	Plate No. 7	110	108	108	110
V9	6BA6 M.M. Amp.	Plate No. 5 Screen No. 6 Cathode No. 7	210 70 7	200 68 6.6	200 68 6.6	184 63 6
V10	6BF6 M.M. Amp. & Rect.	Plate No. 7 Cathode No. 2	121 6.6	117 6.4	117 6.4	107 5.8
V11	6BA6 Reactor	Plate No. 5 Screen No. 6	2.6 36	2.6 35	2.6 35	3.1 45

*Tuning condenser at high frequency end.
†Tuning condenser at low frequency end.

RADIO CHASSIS CATHODE CURRENTS (MA)

Tube	Type	No.	16.9	16.5	16.5	14
V1	6BA6	No. 7	16.9	16.5	16.5	14
V2	6BA6	No. 7	3.1	3.2	3.8	4.9
V3	6BE6	No. 2	0	14.1	14.1	15.8
V4	6BA6	No. 7	14	13.8	13.8	13.2
V5	6AU6	No. 7	1.8	1.8	1.8	3.9
V6	6AU6	No. 7	0	0	0	18.3
V7	6AL5	0	0	0	0
V8	6AT6	No. 2	.25	.25	.25	.25
V9	6BA6	No. 7	.9	.9	.9	.88
V10	6BF6	No. 2	1.3	1.3	1.3	1.2
V11	6BA6	No. 7	1.36	1.35	1.35	1.3

Voltages measured with Chanalyst or VoltOhmyst and should hold within $\pm 20\%$ with rated power supply. No signal. Tuning condenser closed except as stated.

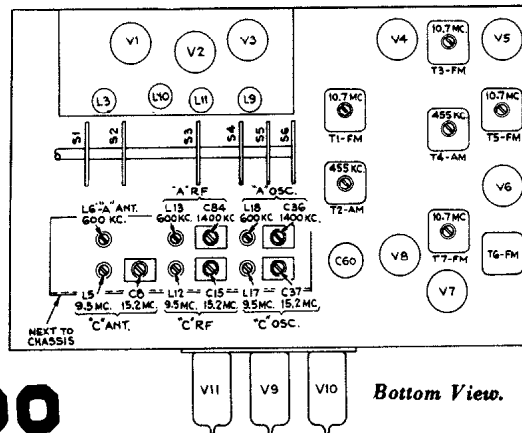
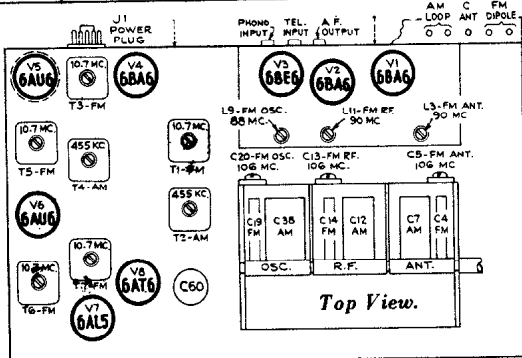

MANUAL OF 1949 MOST-OFTEN-NEEDED RADIO DIAGRAMS

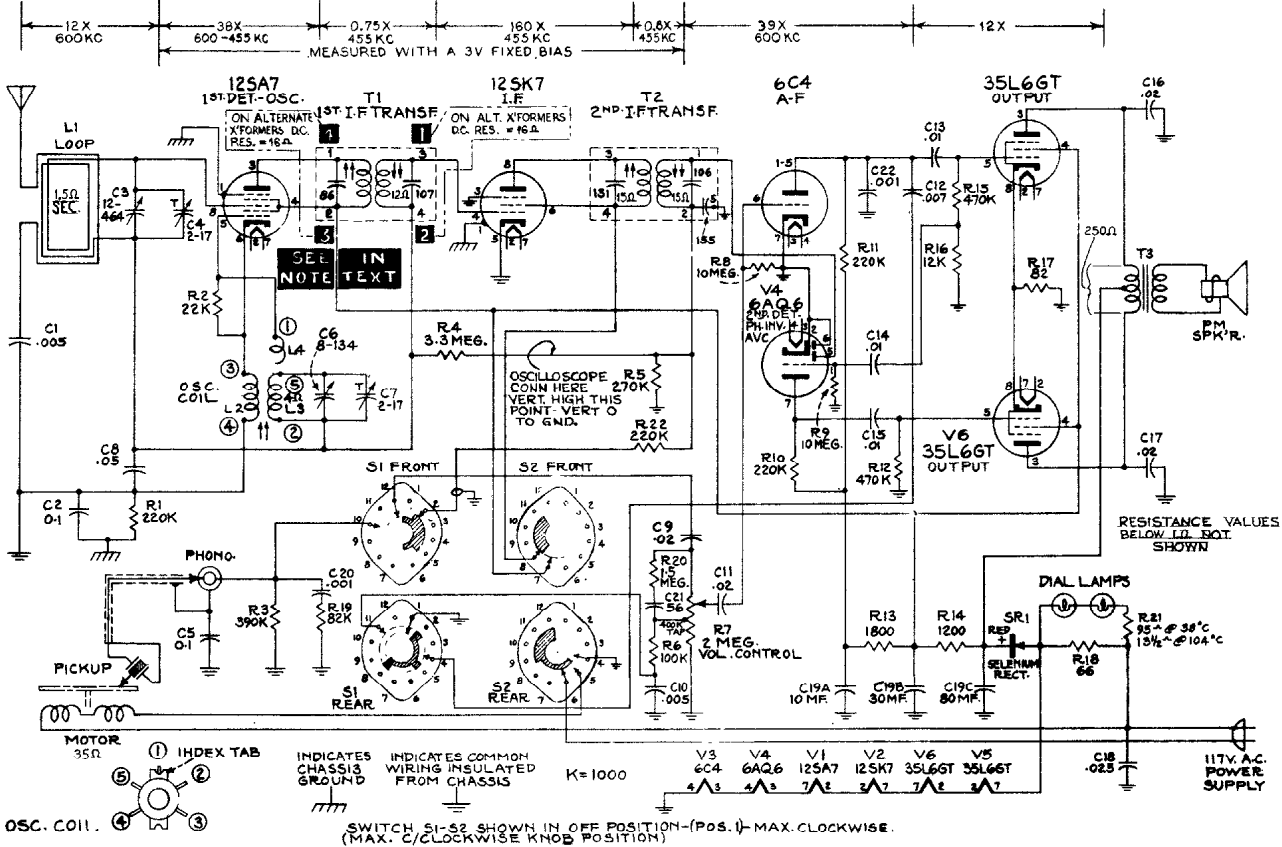

RCA VICTOR 77U

Radio-Phonograph Combination Chassis No. RC-1057A

CAUTION.—CLOSE TUNING CONDENSER PLATES COMPLETELY (C-C-W) BEFORE REMOVING CHASSIS FROM CABINET.
Take off both wooden strips on bottom of cabinet by removing wood screws before loosening chassis bolts.

Dial Pointer Adjustment.—Rotate tuning condenser fully counter-clockwise (plates fully meshed). Adjust indicator pointer so that it is 3/8" from the left hand edge of the dial back plate.

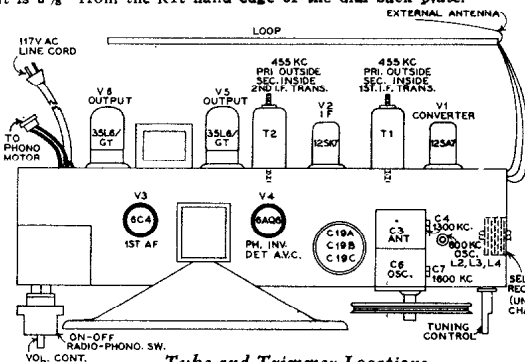

Tube and Trimmer Locations

Tubes 6C4 and 6AQ6 may be replaced by removing the sloping panel (remove four wood screws) in the front of the record changer compartment. Before removing the chassis from the cabinet it is advisable to loosen the two hex screws holding the speaker horizontally. This will allow the chassis to be removed and replaced easily. When the chassis is replaced the dial lights should be adjusted so as not to be visible from the front of the cabinet, and yet to give correct dial lighting. Move the speaker so it is flush against the baffle before retightening the hex nuts. The chassis mounting board should be flush against the front of the cabinet, and the chassis mounting holes should be centered over the holes in the board.

The first I-F transformer shown in the schematic is stamped 970441-1. Some chassis will have a first I-F transformer stamped 970441-5. Connections to this alternate transformer are as shown in the block letters. Performance will be identical for both sets.

Steps	Connect the high side of test-oscillator to—	Tune test-osc. to—	Turn radio dial to—	Adjust the following for max. peak output
1	I.F. grid, in series with .01 mfd.	455 kc	Quiet point 1,600 kc end of dial	Pri. & Sec. 2nd I.F. transformer
2	1st Det. grid in series with .01 mfd.			Pri. & Sec. 1st I.F. transformer

NOTE.—ANTENNA LOOP AND RECORD CHANGER MUST BE IN CABINET

3		1,600 kc	1,600 kc	C7 (osc.)
4	Antenna terminal in series with 220 mmfd.	1,400 kc.	1,400 kc	C4 (ant.)
5		600 kc	600 kc	Osc. Coil L2, L3 Rock gang
6	Repeat steps 3, 4, & 5 if necessary			

Test Oscillator.—Connect high side of test oscillator as shown in chart. Connect low side through a .01 mf capacitor to common "—B". Keep the output signal as low as possible to avoid a-v-c action.

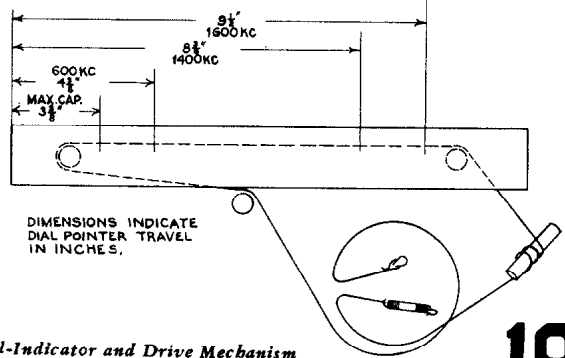

Dial-Indicator and Drive Mechanism

MANUAL OF 1949 MOST-OFTEN-NEEDED RADIO DIAGRAMS

ION RCA VICTOR

Models 8V90, 8V91

1st Prod. Chassis No. RC-618 RC-616A
2nd Prod. Chassis No. RC-618A RC-616H

Tuning Ranges
Standard Broadcast (AM)..... 540-1,600 kc.
Frequency Modulation (FM)..... 88-108 mc.
Intermediate Frequencies...AM—455 kc, FM—10.7 mc.

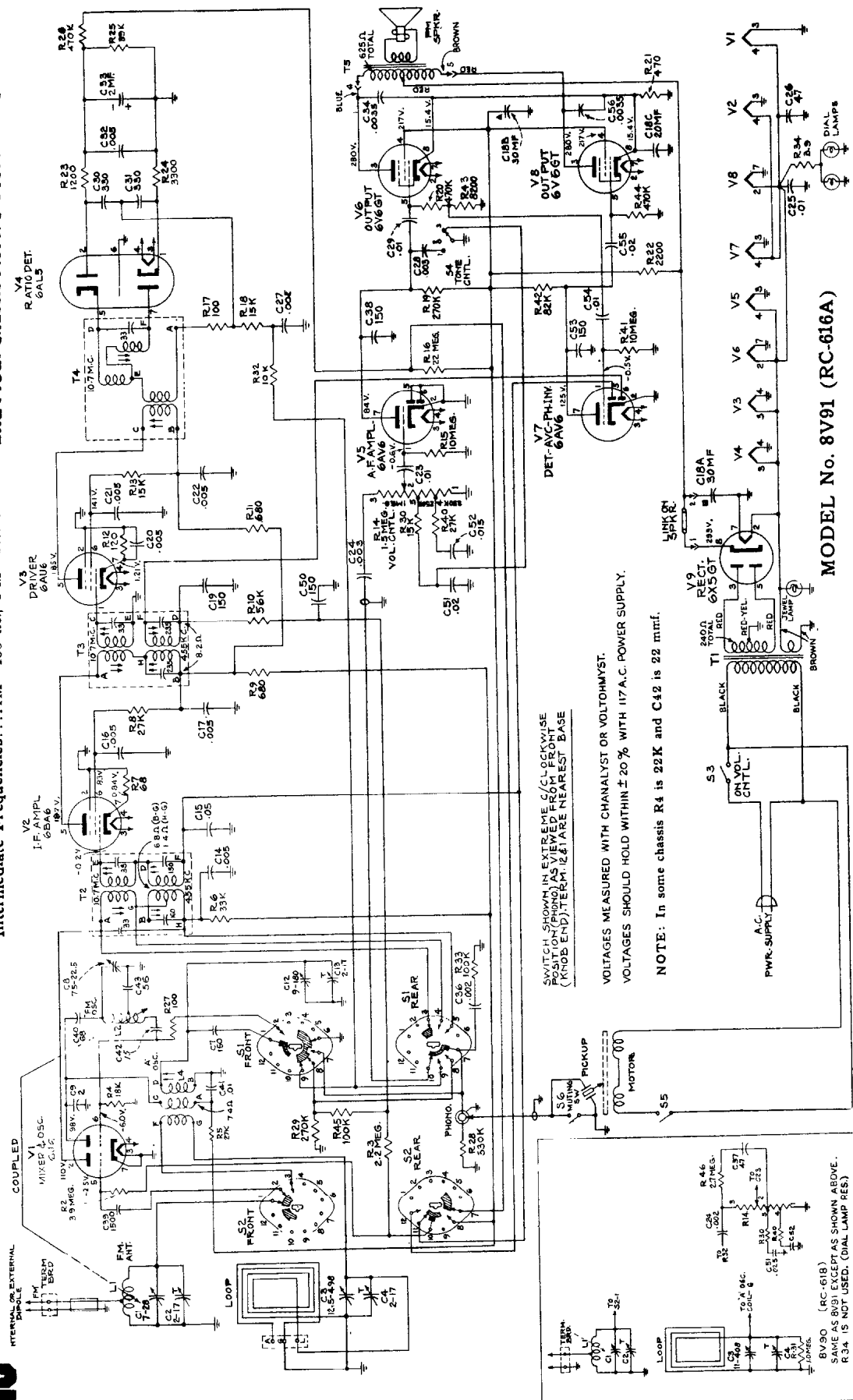

MODEL No. 8V91 (RC-616A)

SWITCH SHOWN IN EXTREME C/CLOCKWISE POSITION (PHONO) AS VIEWED FROM FRONT (KNOB END) TERMINALS ARE NEAREST BASE

VOLTAGES MEASURED WITH CHANNELYST OR VOLTOHMYST.
VOLTAGES SHOULD HOLD WITHIN ± 20% WITH 117 A.C. POWER SUPPLY.

NOTE: In some chassis R4 is 22K and C42 is 22 mmf.

NOTE—2nd I.F. Transformer:
Some chassis may use 2nd I.F. trans. stamped 970435-5 (Stock No. 74019), the 455 kc. windings have a d.c. resistance of 12 ohms each, the resonating capacitors are 150 mmf. instead of 235 mmf. They are interchangeable with transformers stamped 970435-2 (Stock No. 73363).

MANUAL OF 1949 MOST-OFTEN-NEEDED RADIO DIAGRAMS



RCA VICTOR

8X521, 8X522

Chassis No. RC-1066 RC-1066A

POWER SUPPLY POLARITY.—For operation on d-c, the power plug must be inserted in the outlet for correct polarity. If the set does not function, reverse the plug. On a-c, reversal of the plug may reduce hum.

Critical Lead Dress

1. Dress all heater leads close to chassis.
2. Dress output plate bypass capacitor C11 inside of terminal board.
3. Dress all exposed leads away from each other and away from chassis.

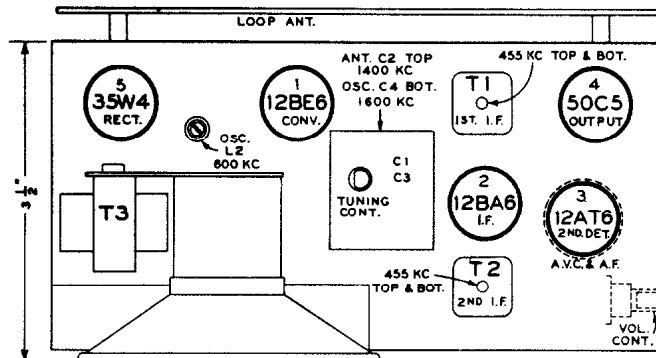

Alignment Procedure

Cathode Ray Alignment is the preferable method. Connections for the oscilloscope are shown on the schematic diagram.

Output Meter Alignment.—If this method is used, connect the meter across the voice coil, and turn the receiver volume control to maximum.

Test-Oscillator.—For all alignment operations, connect the low side of the test-oscillator to the receiver chassis, and keep the oscillator output as low as possible to avoid a-v-c action.

On AC operation an isolation transformer (115 v./115 v.) may be necessary for the receiver if the test oscillator is also AC operated.

For additional information refer to booklet "RCA Victor Receiver Alignment."

NOTE.—If the speaker should be removed in servicing, its position should be checked when re-assembling. The distance between the front of the speaker and the rear chassis apron should be maintained at 3½ inches.

Steps	Connect the high side of test-oscillator to—	Tune test-osc. to—	Turn radio dial to—	Adjust the following for max. output
1	12BA6 I-F grid through 0.1 mfd. capacitor	455 kc	Quiet-point 1,600 kc end of dial	T-2 (top and bottom) 2nd I-F trans.
2	Stator of C1 through 0.1 mfd.			T-1 (top and bottom) 1st I-F trans.
3	Short wire placed near loop to radiate signal.	1,600 kc	1,600 kc	C4 (osc.)
4		1,400 kc	1,400 kc	C2 (ant.)
5		600 kc	600 kc	L2 (osc.) Rock gang
6	Repeat steps 3, 4 and 5.			

*Do not readjust T-2 when test oscillator is connected to C1.

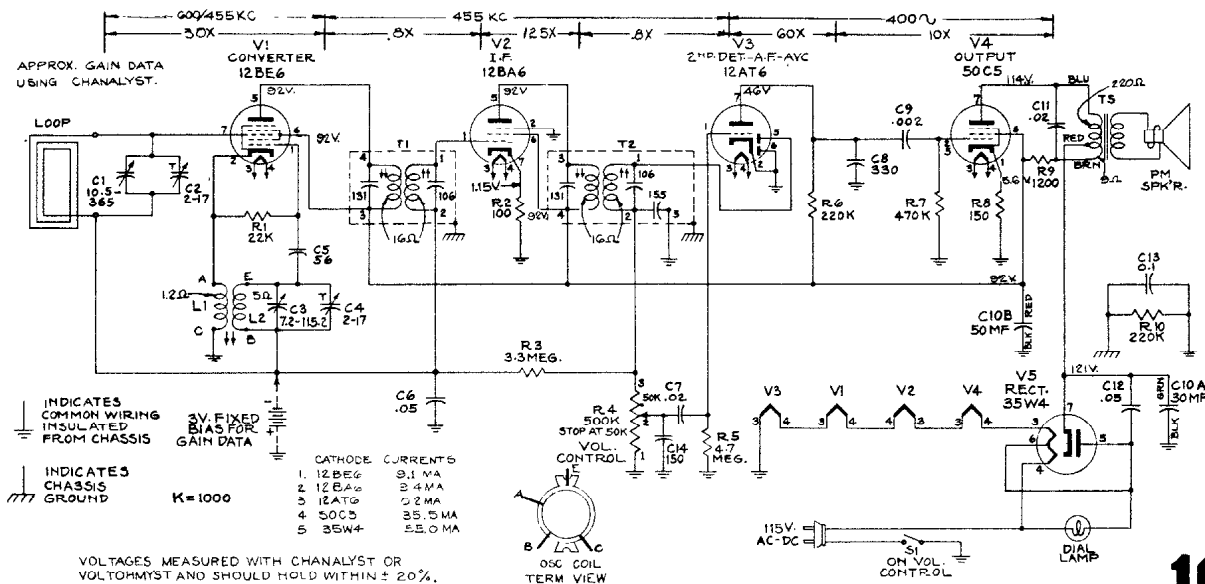

MANUAL OF 1949 MOST-OFTEN-NEEDED RADIO DIAGRAMS

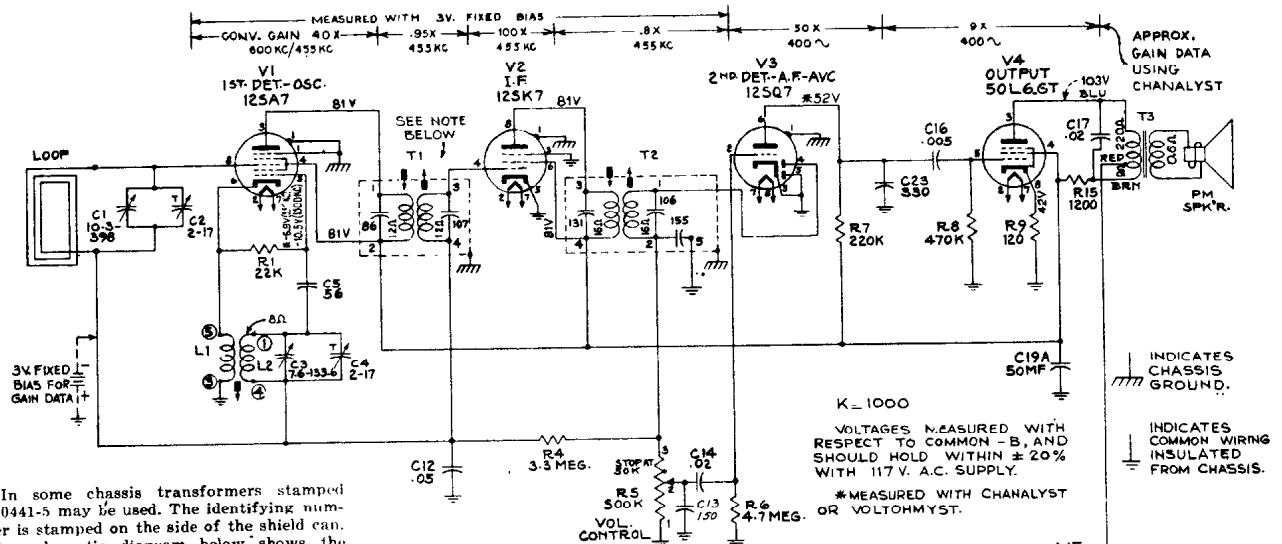

In some chassis transformers stamped 970441-5 may be used. The identifying number is stamped on the side of the shield can. The schematic diagram below shows the connections, d-c resistance and shunt capacitors of transformers stamped 970441-5.

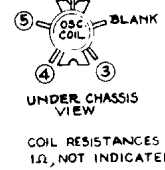
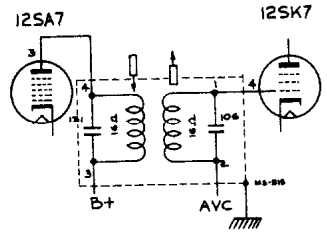

RCA VICTOR Model 8X53

Chassis No. RC-1064

Alignment Procedure

- Output Meter Alignment.**—If this method is used, connect the meter across the voice coil, and turn receiver the volume control to maximum.
- Test-Oscillator.**—For all alignment operations, connect the low side of the test-oscillator to the receiver chassis, and keep the oscillator output as low as possible to avoid a-v-c action.
- Calibration Scale.**—The glass tuning dial may be removed from the cabinet and mounted above the pointer for reference during alignment. The extreme left hand mark of the Standard Broadcast scale must be in line with the left hand mark on the dial backing plate.
- Dial Backing Plate.**—In the event that only the chassis is returned for service, the marks on the dial backing plate may be used during alignment; refer to the Dial Indicator and Drive Mechanism drawing for corresponding frequencies.
- Dial Pointer.**—With the gang condenser in full mesh the dial pointer should be set to the left hand reference mark on the dial backing plate. For additional information refer to booklet, "RCA Victor Receiver Alignment."

Steps	Connect the high side of test-oscillator to—	Tune test-osc. to—	Turn radio dial to—	Adjust the following for max. peak output
1	12SK7 I-F grid through 0.1 mfd. capacitor	455 kc	Quiet-point 1,600 kc end of dial	T2 Top & bottom 2nd. I-F trans.
2	Stator of C1 through 0.1 mfd.			*T1 Top & bottom 1st. I-F trans.
3	Short wire placed near loop antenna	1,300 kc	1,300 kc	C4 (osc.) C2 (ant.)
4		600 kc	600 kc "A" Band	L2 (osc.) Rock gang
5	Repeat steps 3 and 4			

*Do not readjust T2 when test oscillator is connected to C1.

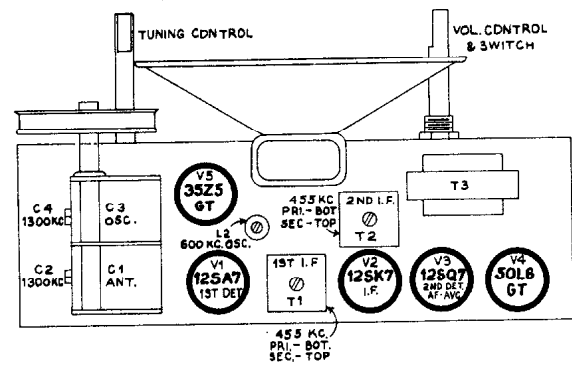
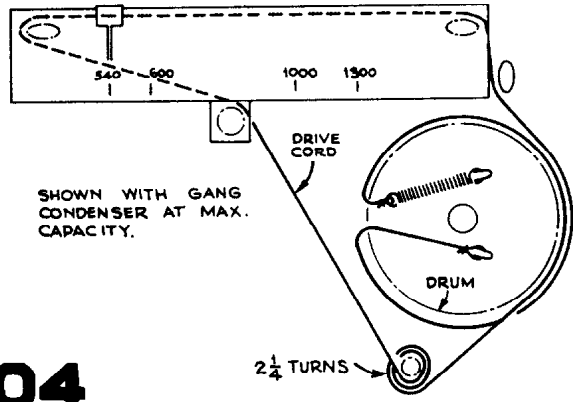

MANUAL OF 1949 MOST-OFTEN-NEEDED RADIO DIAGRAMS



RCA VICTOR

8X541, 8X542, 8X547

Chassis No. RC-1065, RC-1065A

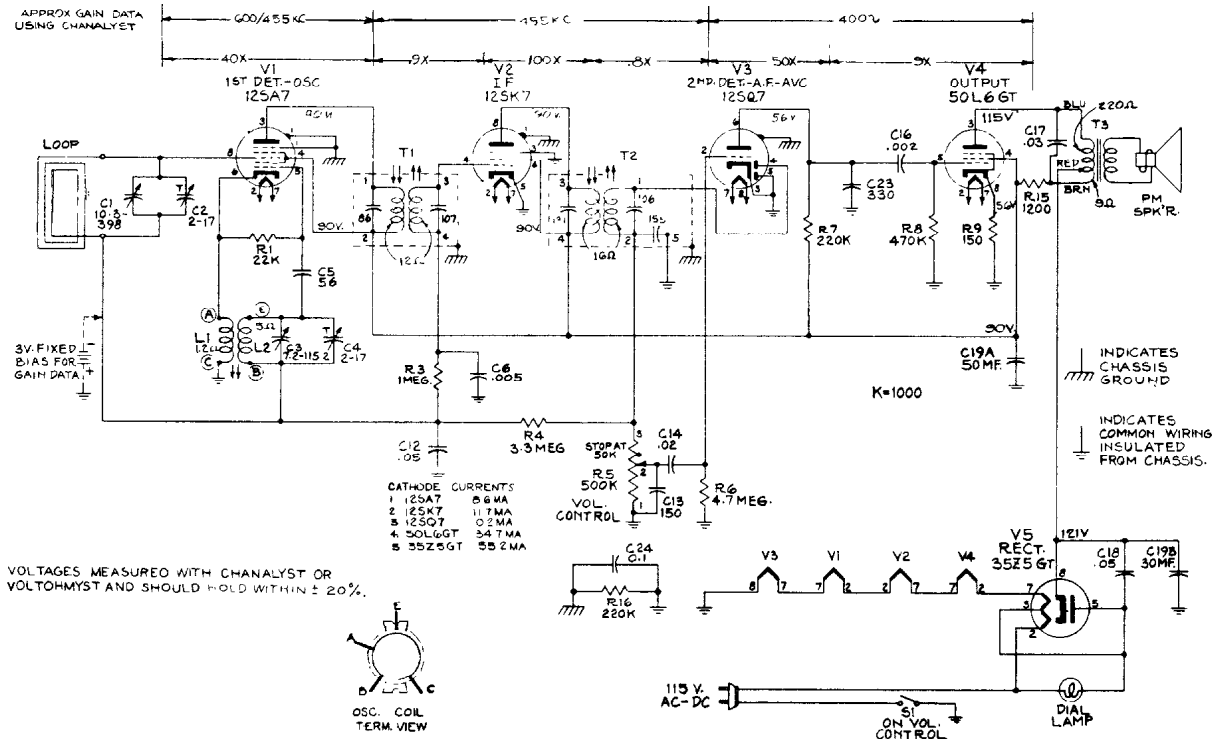

Alignment Procedure

Cathode-Ray Alignment is the preferable method. Connections for the oscilloscope are shown in the schematic diagram.

Output Meter Alignment.—If this method is used, connect the meter across the voice coil, and turn the receiver volume control to maximum.

Test-Oscillator.—For all alignment operations, connect the low side of the test-oscillator to the receiver chassis, and keep the oscillator output as low as possible to avoid a-v-c action.

On AC operation an isolation transformer (115 v./115 v.) may be necessary for the receiver if the test oscillator is also AC operated.

Dial Centering:

If the mounting of the tuning condenser has been disturbed, it may be necessary to adjust its position after replacing the chassis in the cabinet. This may be done in the following manner:

1. Install chassis and tighten the three mounting screws.
2. Replace tuning knob.
3. Loosen the two screws which hold the tuning condenser mounting bracket to the chassis.
4. Adjust the position of the tuning condenser mounting bracket so that the tuning knob may be rotated without binding on the cabinet. With tuning condenser plates fully meshed the dial should be in the position indicated below.
5. The two screws should then be tightened to maintain this position.

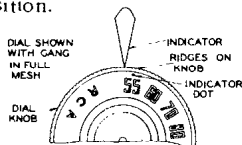

Steps	Connect the high side of test-oscillator to—	Tune test-osc. to—	Turn radio dial to—	Adjust the following for max. output
1	12SK7 1-F grid through 0.1 mfd. capacitor	455 kc	Quiet-point 1600 kc end of dial	T2 (Top and bottom) 2nd 1-F trans.
2	Stator of C1 through 0.1 mfd.			*T1 (top and bottom) 1st 1-F trans.
3	Short wire placed near loop to radiate signal	1600 kc	1600 kc	C4 (osc.)
4		1400 kc	1400 kc	†C2 (ant.)
5		600 kc	600 kc	L2 (osc.) Rock gang
6	Repeat steps 3, 4 and 5.			

*Do not readjust T2 when test oscillator is connected to C1.

†When adjusting C2 (ant. trimmer) it is necessary to have the loop in the same position and spacing as it will have when assembled in the cabinet. This spacing is 3/4" from chassis to loop.

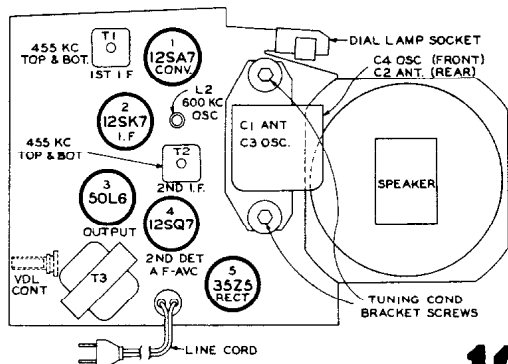

MANUAL OF 1949 MOST-OFTEN-NEEDED RADIO DIAGRAMS

RCA VICTOR



75X11, 75X12 Chassis No. RC-1050

Critical Lead Dress

1. Dress all heater leads close to chassis.
2. Dress AVC resistor R4 away from 12SK7 tube socket.
3. Dress diode load resistor R3 away from 12SQ7 tube socket.
4. Dress 12SQ7 plate resistor R7 over 2nd IF transformer terminal.
5. Dress output plate bypass capacitor C17 close to rear of chassis.
6. Dress power cord lead along rear and bottom of chassis between 35Z5GT and 50L6GT tubes.

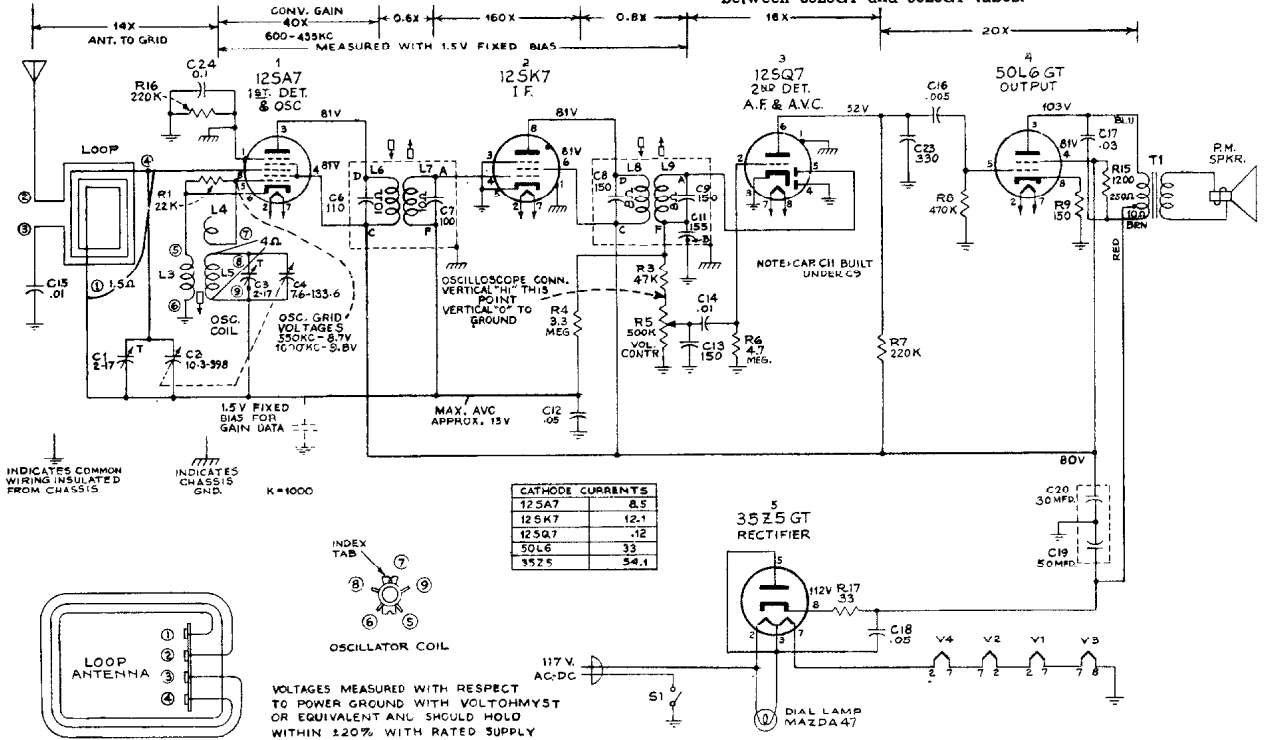

Alignment Procedure

Output Meter Alignment.—If this method is used, connect the meter across the voice coil, and turn the receiver volume control to maximum.

Test-Oscillator.—For all alignment operations, connect the low side of the test-oscillator to the receiver chassis, and keep the oscillator output as low as possible to avoid a-v-c action.

Calibration Scale.—The tuning dial can not be used for accurate alignment. Use of the procedure given in the alignment tabulation will provide satisfactory calibration.

Dial Pointer.—With the tuning condenser in full mesh the dial pointer should be adjusted to approx. 17.0° counterclockwise from the vertical position. It should be adjusted before re-assembling the bezel to the cabinet.

Dis-assembly.—To remove bezel and dial assembly:
Remove the four hex head screws in the feet.
To remove chassis from cabinet:
Remove bezel and dial assembly described above, remove the pointer by pulling straight to the front, remove four round head screws which hold the chassis to the cabinet.

Steps	Connect the high side of test-oscillator to—	Tune test-osc. to—	Turn radio dial to—	Adjust the following for max. peak output
1	12SK7 I-F grid through 0.1 mfd. capacitor	455 kc	Quiet-point 1,600 kc end of dial	L8 and L9 2nd I-F transformer
2	Stator of C2 through 0.1 mfd.			L8 and L7 1st I-F transformer
3		1,620 kc	full clock- wise	C3 (osc.)
4	Ant. lead in series with 200 mmfd.	1,400 kc	1,400 kc	C1 (ant.)
5		600 kc	800 kc "A" Band	L5 (osc.) Rock gang
6	Repeat steps 3, 4 and 5.			

* Do not readjust L8 or L9 when test oscillator is connected to C2.

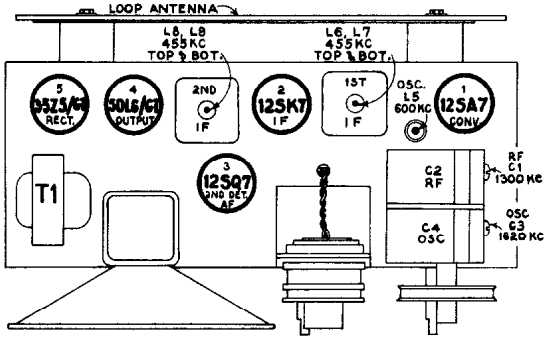
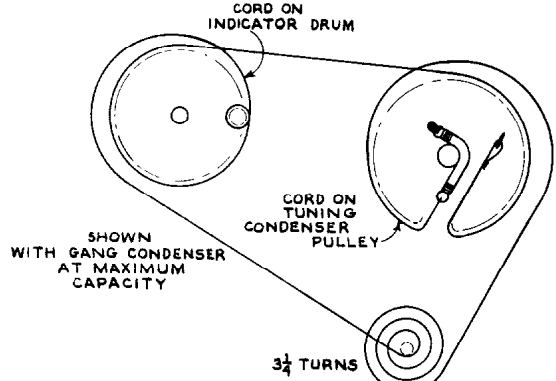

MANUAL OF 1949 MOST-OFTEN-NEEDED RADIO DIAGRAMS



RCA VICTOR

MODELS 8X681, 8X682

Chassis No. RC-1061

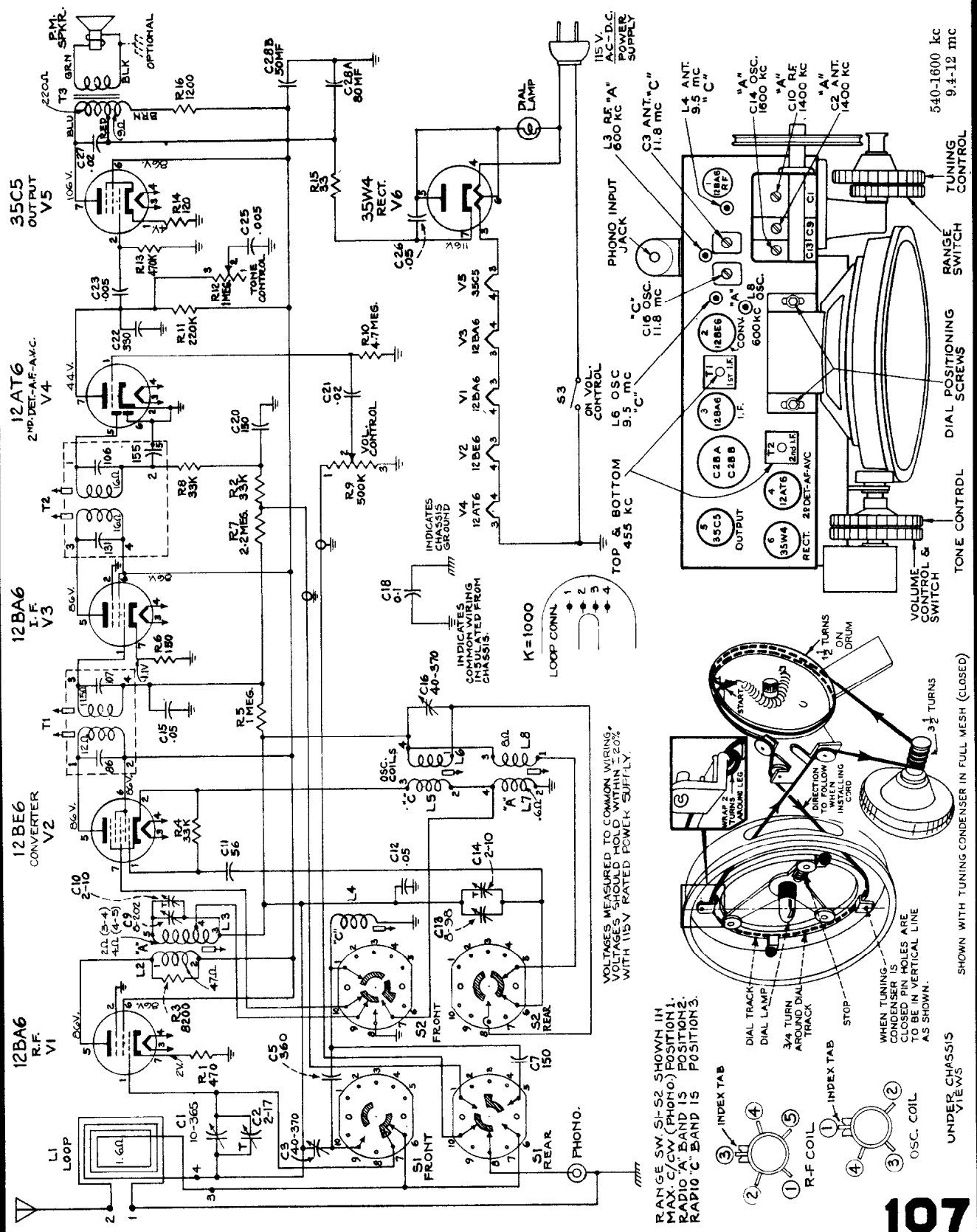

RCA VICTOR

Model 8V112
Chassis No. RC-616

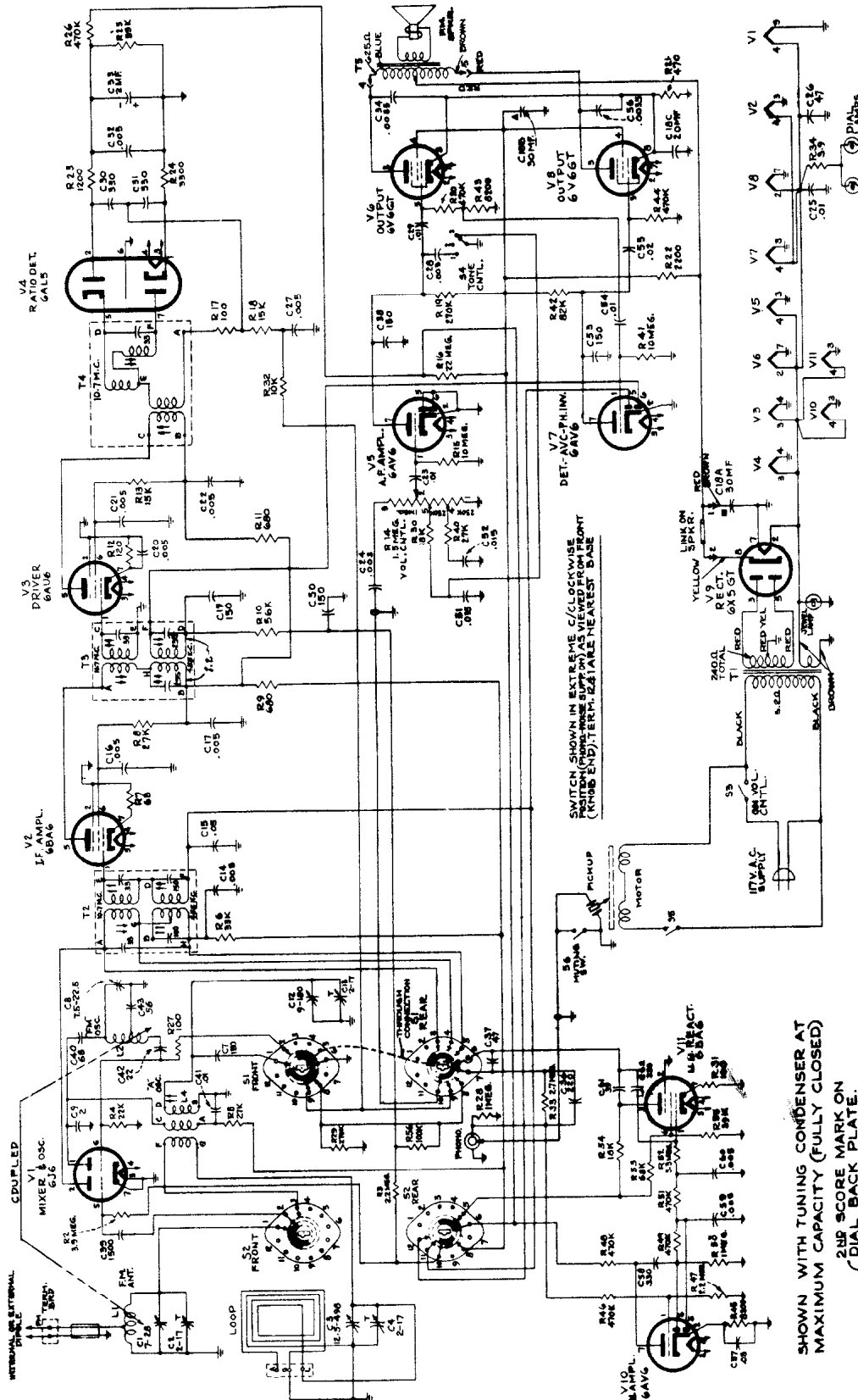

MAGIC MONITOR

Circuit Description

The Magic Monitor circuit acts as a capacity shunt across the audio input to the volume control when the selector switch is turned to M. M. position. This shunt is variable, diminishing with increasing input level and increasing with increase of frequency. The phono signal input is applied to the grid of V10 (6AV6 M. M. amp.), is amplified and fed through a resistance-capacity network to the diode plates of V10 which rectifies it and produces a grid voltage on V11 in proportion to the level of the high frequencies contained in the audio signal.

Tuning Ranges

Standard Broadcast (AM) 540-1,600 kc.
Frequency Modulation (FM) 88-108 mc.
Intermediate Frequencies AM—455 kc., FM—10.7 mc.

SHOWN WITH TUNING CONDENSER AT MAXIMUM CAPACITY (FULLY CLOSED)

2 1/2 TURNS MARK ON DIAL BACK PLATE.

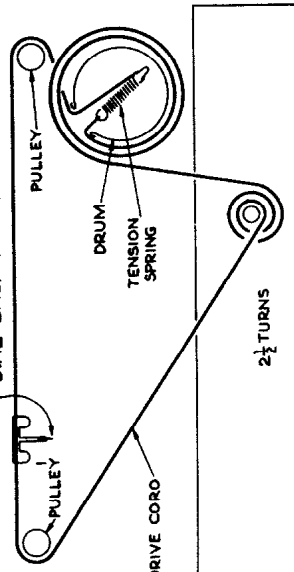

MANUAL OF 1949 MOST-OFTEN-NEEDED RADIO DIAGRAMS

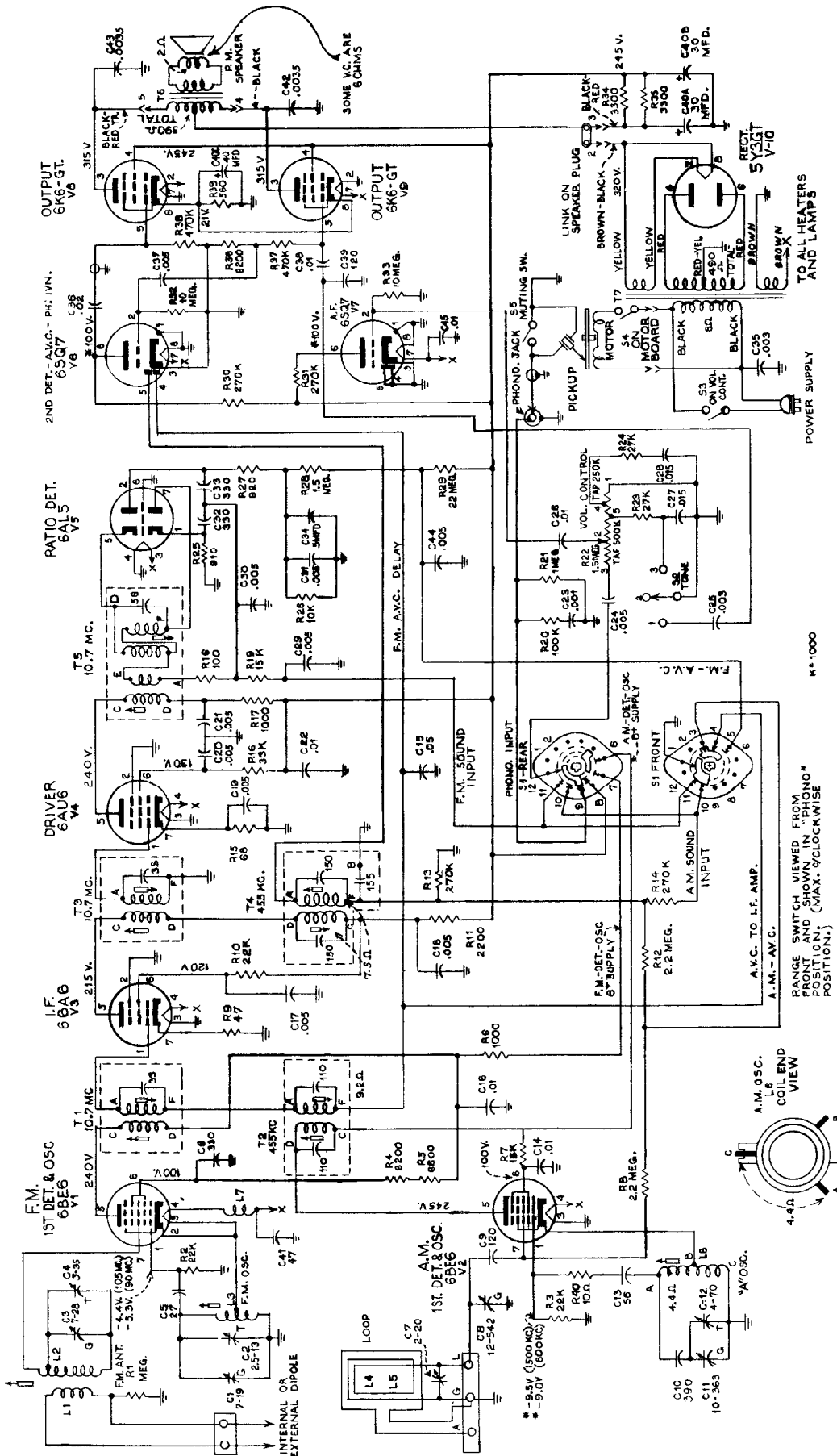

VOLTAGES SHOULD HOLD WITHIN ±20% WITH 117V. A.C. RATED SUPPLY.

* VOLTAGES MEASURED WITH CHANNEL 151 OR VOLTOHM 51.

RANGE SWITCH VIEWED FROM POSITION 1 (A.M. - CLOCKWISE POSITION 4.)

R.C.A. Victor
Model 710V2
Chassis RC-613A
Alignment on next page

The audio outputs of the AM second detector and the FM ratio detector are connected thru a section of the range switch to the volume control input.

The B+ supply (+245 V) to the plates and screen grids of V1 and V2 is controlled thru a section of the range switch.

Simple AVC is used on AM and is applied to both the IF amplifier (V3) and the AM 1st detector (V2). Delayed AVC is used on FM and is applied only to the IF amplifier (V3). The AVC distribution is controlled thru a section of the range switch.

Circuit Description

Model 710V2 has individual built-in antennas for FM and AM coupled to individual 1st Det.-Osc. tubes (6BE6 V1 and V2). The outputs of these two tubes are connected to separate IF transformers (T1 and T2) whose secondaries are in series and connected to the IF amplifier tube (6BA6 V3). The output of V3 is connected to separate IF transformers (T3 and T4) whose primaries are in series. The secondary of T3 (FM IF) is connected to the driver tube (6AU6 V4). The secondary of T4 (AM IF) is connected to the AM second detector (6SQ7 V6). The output of the driver tube (V4) is coupled thru the ratio detector transformer (T5) to the FM ratio detector tube (6AL5 V5).

MANUAL OF 1949 MOST-OFTEN-NEEDED RADIO DIAGRAMS

RCA VICTOR MODEL 710V2

AM-FM Radio-Phonograph Combination

Chassis No. RC-613A

FREQUENCY RANGES

Standard Broadcast (BC)540-1600 kc.
Frequency Modulation (FM)88-108 mc.
Intermediate Frequency (AM)455 kc.
Intermediate Frequency (FM)10.7 mc.

Alignment Indicators:

An RCA VoltOhmyst or equivalent meter is necessary for measuring developed d-c voltage during FM alignment. Connections are specified in the alignment tabulation below. An output meter is also necessary to indicate minimum audio output during alignment. Connect the output meter across the speaker voice coil.

The RCA VoltOhmyst can also be used as an AM alignment indicator, either to measure audio output or to measure a-v-c voltage.

When audio output is being measured the volume control should be turned to maximum.

Signal Generator:

For all alignment operations, except as stated in FM alignment, connect the low side of the signal generator to the receiver chassis. The output should be adjusted to provide accurate resonance indication at all times. If output measurement is used for AM alignment the output of the signal generator should be kept as low as possible to avoid a-v-c action.

Critical Lead Dress

1. Dress capacitor C5 near chassis base.
2. Dress lead from pin 5, V-1, to terminal C, of transformer T1, as near bottom of FM shelf as possible.
3. The lead from capacitor C24 to the high side of the volume control must be dressed next to chassis along front apron.
4. Dress resistors R32 & R33 near chassis base.
5. Dress all A.C. leads away from volume control.
6. Solder FM antenna coil primary leads to terminal board with as short a lead length as is practical.
7. Make all FM leads as short as possible.
8. The lead from pin 2, V-3, to chassis ground must be dressed as close to base and as near to the back apron as possible. This lead provides degeneration for the IF stage and neither its length nor the point at which it is grounded to the chassis should be changed.
9. Dress all leads away from the 8800 ohm resistors R34 and R35.

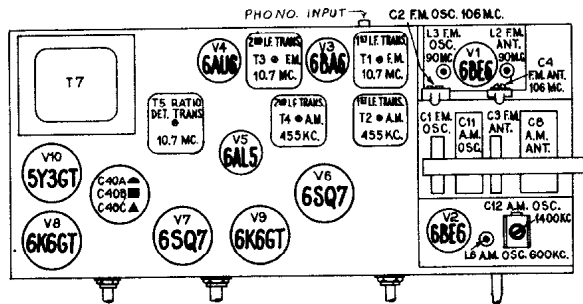

TOP VIEW OF CHASSIS

The FM i-f alignment may be checked by means of an FM sweep generator and cathode ray oscilloscope. Connect the output from the sweep generator, which is set to 10.7 mc., to the FM 1st Det.-Osc. grid (6BE6 Pin No. 7) low side to chassis. Disconnect the 5 mfd. capacitor C34 from the Ratio Detector circuit.

Connect the high side of the oscilloscope to the junction of R27 and R28, low side to chassis. Adjust the sweep generator and oscilloscope to obtain the response curve.

The Ratio Detector characteristic may be viewed by connecting the oscilloscope across the volume control R22. Capacitor C34 should be re-connected before checking the Ratio Detector characteristic.

FM Alignment

RANGE SWITCH IN FM POSITION—VOLUME CONT. MAXIMUM

Steps	Connect sig. gen.	Sig. gen. output	Turn radio dial to—	Adjustment for peak output
1	Connect the d-c probe of a VoltOhmyst to the negative lead of the 5 mfd. capacitor C34 and the common lead to chassis. Turn gang condenser to max. capacity (fully meshed).			
2	High side to Pin 1 of driver tube 6AU6 in series with .01 mfd. low side to chassis	10.7 mc. modulated 30% 400 cycles AM (Approx. .1 volt)	Max. capacity (fully meshed)	T5 top core for max. d-c voltage across C34. T5 bottom core for min. audio output
3	High side to one FM ant. term. in series with .01 mfd. Low side to the other FM ant. term.	10.7 mc. 30% modulation, 400 cycles AM. Adjust to provide 2 to 3 volts indication on VoltOhmyst during alignment.		fUsing alternate loading: T3 bottom core (sec.) T3 top core (pri.) T1 bottom core (sec.) T1 top core (pri.)
4	High side to one FM ant. term. in series with a 120 ohm resistor. Low side to the other FM ant. term. in series with a 120 ohm resistor.	106 mc	106 mc	C2 osc. C4 ant.
5	High side to one FM ant. term. in series with a 120 ohm resistor.	90 mc	90 mc	L3 osc. L2 ant.
6	Repeat Steps 4 and 5 until further adjustment does not improve calibration.			

†Alternate loading involves the use of a 680 ohm resistor to load the plate winding while the grid winding of the SAME TRANSFORMER is being peaked. Then the grid winding is loaded with the resistor while the plate winding is peaked. Only one winding is loaded at any one time. Remove the 680 ohm resistor after T3 and T1 have been aligned.

AM Alignment

(Correct alignment of the 455 kc. IF requires that the 10.7 mc. IF be aligned previously)

RANGE SWITCH IN BC POSITION

Steps	Connect high side of sig. gen. to—	Sig. gen. output	Turn radio dial to—	Adjust for peak output
1	AM converter grid 6BE6 V-2 in series with .01 mfd.	455 kc	Quiet point at low freq. end.	†T4 top core (sec.) †T4 bottom core (pri.)
2				†T2 bottom core (sec.) †T2 top core (pri.)
3	"A" terminal of terminal board at rear of chassis in series with 200 mmf. (link open)	1400 kc	1400 kc	C12 osc. C 7 ant. (loop)
4		600 kc	600 kc	L6 osc. (Rock gang)
5	Repeat Step 3.			
6	After chassis and loop have been installed in cabinet, adjust C7 for max. output on a weak station near 1400 kc.			

†Align T4 and T2 by means of alternate loading as explained under FM alignment. Use a 47,000 ohm resistor instead of a 680 ohm resistor.

Oscillator frequency is above signal frequency on both AM and FM.



FRONT PANEL CONTROLS

RCA VICTOR

RP-178 Series Automatic Record Changer

SERVICE DATA

Continued on the next seven pages

RADIO CORPORATION OF AMERICA

RCA VICTOR DIVISION
CAMDEN, N. J., U. S. A.

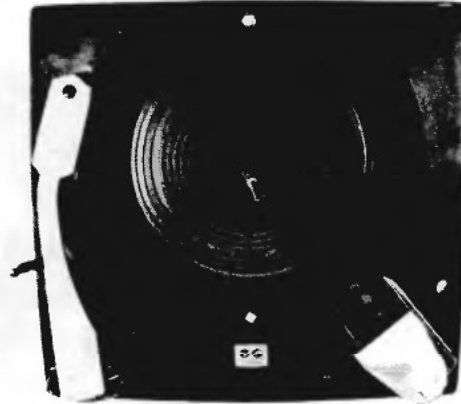

RP-178 Series Record Changer

RP-178

Uses 117V. 60 cycle motor. For operation on 50 cycle power supply; a spring, Stock No. 73158 is added to the motor shaft. Used in the following models: 8TV321, 8TV323, 8V7, 8V90, 8V91, 8V112, 75ZU, 77U, 77V1.

RP-178-2

Uses 117V. 25 cycle motor. Used in instruments manufactured by RCA Victor Company Limited (Canada).

RP-178-3

Uses 117V./234V. 60 cycle motor. For operation on 50 cycle power supply; a spring, Stock No. S-4774 is added to the motor shaft. Used in Models 6QU3 and 6QV3.

Index

Function of Principal Parts	
Adjustments	
Tone Arm (Out of Cycle) Height Adjustment	
Tone Arm Height Adjustment While in Change Cycle	
Pickup Landing Adjustment	
Record Push Cam and Gear Assembly Adjustment	
Removing Turntable	
Replacing Turntable	
Turntable Centering	
Cycle of Operation	
Illustrated Service Hints	
Pickup Repeats Grooves	
Continuous Tripping	
Premature Tripping	
Failure To Trip or Go Into Cycle	
Changer Will Not Complete Cycle	
Records Do Not Separate or Drop Properly	
Distorted Output	
"Wow" or Slow Turntable Speed	
Improper Pickup Landing	
Rumble	

FEATURES

1. This mechanism is designed to play automatically a series of twelve 10-inch or ten 12-inch standard records of the 78 r.p.m. type.
2. It will play manually records up to 12 inches in diameter.
3. Tripping system is of "eccentric" type, insuring reliable automatic operation on all records made to RMA proposed standards.
4. It is a simple operation of sliding the record support to change from 10- to 12-inch records or vice versa.
5. Cycling mechanism is disconnected completely while records are being played. This reduces the load on the drive motor, thereby reducing the tendency for "wow" or rumble.
6. Low noise sapphire point pickup cartridge.

AUTOMATIC OPERATION

1. With the power switch in the off position slide the record support shelf as required for 10- or 12-inch records.
2. Place the records to be played in a stack with desired selections upward and in proper sequence with the last record on top. Load them on the changer by placing them over the center post and resting on the record support shelf. Place record stabilizing clamp on top of the record stack.
3. Turn power switch on and press the reject button. The changer will play automatically one side of each record in the stack. The tone arm can be moved to the rest position any time the mechanism is not in cycle.
4. Turn the power switch off, lift the stabilizing clamp and remove the stack from the turntable by placing fingers of both hands directly opposite and under the stack. Then lift straight up—"don't tilt" or squeeze stack.

MANUAL OPERATION

1. Slide the record support shelf in towards the center post for 10-inch or away from the center post for 12-inch position.
2. Place the record to be played on the turntable and turn the power switch on.
3. Place the pickup on the start of the record.
Note: The mechanism should be allowed to complete cycle before attempting to move tone arm to the rest position.
4. Turn power switch off manually.
5. Remove the record by raising straight up without tilting.

CAUTIONS

1. Avoid handling the tone arm or sliding the record support assembly while mechanism is in cycle.
2. Never turn the power switch off, leaving the mechanism in cycle for an extended period of time.
3. Do not allow the records to remain on supports when not in use.
4. Do not allow oil or grease to come in contact with any rubber parts.
5. Do not install instrument near source of heat. Excessive heat may damage the pickup cartridge.

MANUAL OF 1949 MOST-OFTEN-NEEDED RADIO DIAGRAMS

RP-178 SERIES

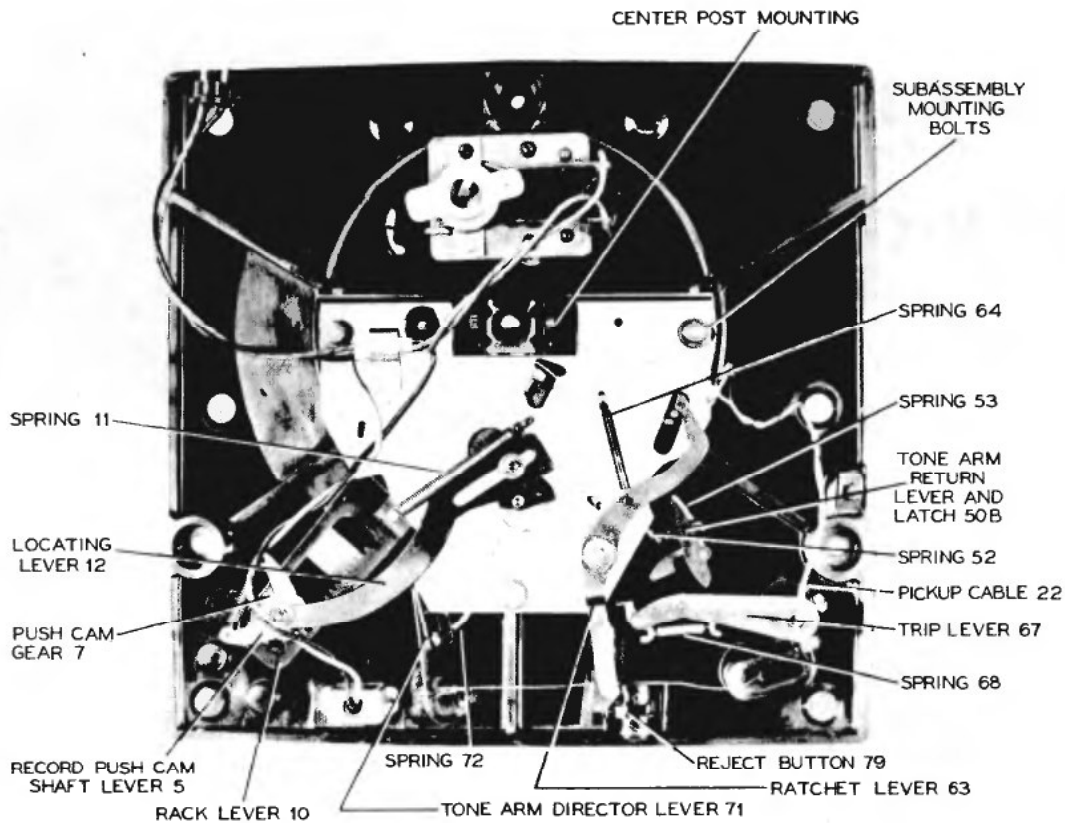

Figure 1

FUNCTION OF PRINCIPAL PARTS

Trip Lever—67

When the sapphire is riding the eccentric groove, the trip pawl engages the ratchet lever, starting cycle.

Ratchet Lever—63

Portion of the lever acts as a ratchet and the other portion incorporates a catch for the stud on the cycling cam carriage. The engagement of this stud prevents the mechanism from going into cycle.

Center Post—32

The center post performs the function of supporting and aids in the separation of the records.

Tone Arm Return Lever and Latch—53B

The tone-arm return lever, together with the latch, locks and stabilizes the tone arm in its outermost position. It also gives the necessary inward motion to the tone arm.

Cycling Cam Carriage—50A

This carriage provides a movable support for the cycling cam.

Tone Arm Director Lever—71

The roller on one end of this lever follows a channel in the cycling cam and thereby pulls on the cable directing the vertical and outward motion of the tone arm.

Locating Lever—12

The sloped portion of the lever forms a stop for the stud on the tone arm return lever thereby determining the landing position of the pickup.

Record Push Cam Gear Assembly—5, 7

Provides a means of coupling the push cam to the rack lever.

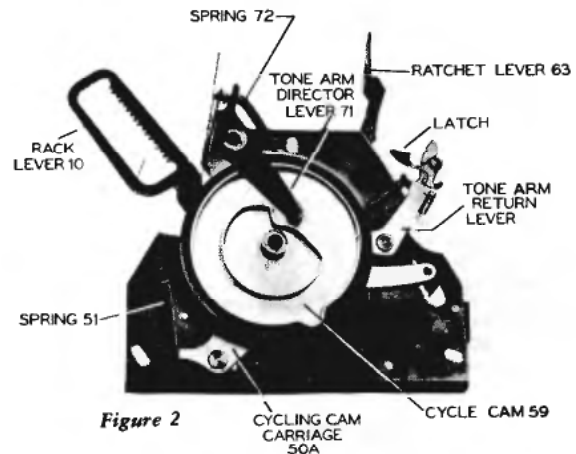

Figure 2

Record Support—1A, B, C, D

Provides a support for the edge of the records and a mounting for the record push cam.

Rack Lever—10

One end of the lever follows the eccentric elevated portion of the cycling cam causing the lever to move in and out from the center of the mechanism. The teeth on the rack lever engage the teeth in the record push cam gear producing a rotary motion necessary to push the record off the step in the center post.

Record Push Cam—4

The oval shaped cam located in the record support, rotates during change cycle. This cam engages and pushes the record from the step in the center post.

MANUAL OF 1949 MOST-OFTEN-NEEDED RADIO DIAGRAMS

RP-178 SERIES

ADJUSTMENTS

Tone arm (out of cycle) height adjustment

1. Rotate the turntable until the change cycle is completed.
2. Move the tone arm to a position off the edge of the record and allow it to rest freely in air.
3. Bend portion of the tone arm bracket so that the sapphire is $\frac{3}{16}$ inches above the flat surface of the motorboard. (Figure 3.)

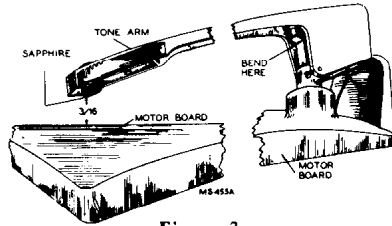

Figure 3

Tone arm height adjustment while in change cycle

1. Press the reject button and rotate the turntable by hand until the pickup has raised, to the maximum height in the change cycle.
2. Turn the adjustment screw "A" until the sapphire is $1\frac{1}{8}$ inches above the turntable. This adjustment will permit the pickup to land and play one record placed on the turntable. At the same time it prevents the tone arm from touching the record resting on the centerpost while the mechanism is going through cycle. (If this height cannot be reached by the adjustment screw, take up on the cotter pin.) (Figures 4 and 5.)

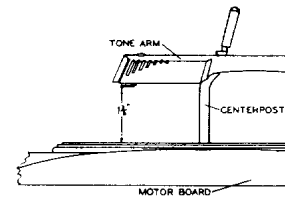

Figure 4

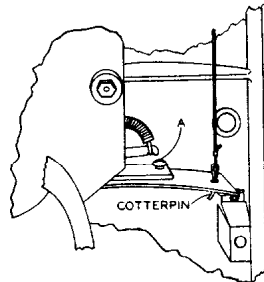

Figure 5

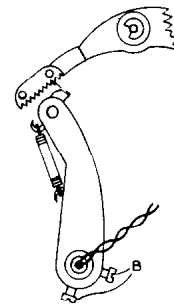

Figure 6

Pickup landing adjustment

1. Slide the record support as required for playing 10-inch records.
2. Place a ten-inch record on the turntable and rotate the turntable by hand until the sapphire is just ready to land. Loosen set screws "B" (Figure 6).
3. Hold the trip lever to keep it from moving while the pickup is moved to the start of the record.
4. Tighten the black screw "B" and allow the mechanism to run through cycle automatically. If landing is correct, tighten copper plated screw "B." (Figure 6.) (Note) No separate 12-inch landing adjustment is necessary.

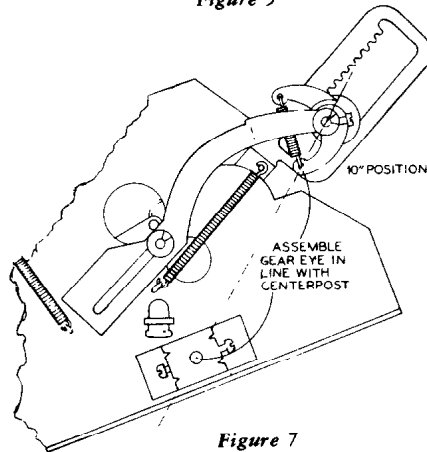

Figure 7

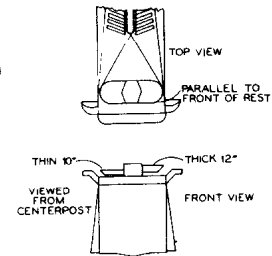

Figure 8

Record push cam and gear assembly adjustment

1. Have the mechanism out of cycle.
2. With the push cam in place and the record support in the 10-inch position, assemble and engage the teeth of the push cam gear with the rack lever so the eye in the lever is approximately in line with the centerpost as shown in drawing. (Figure 7.)
3. Set the push cam parallel to the front edge of the record support, make certain the thin edge of the cam is on the left side, viewed from the front or centerpost side of the support. (Figure 8.)

Removing the turntable

1. Loosen the two screws mounting the centerpost. (Figure 10.)
2. The centerpost, turntable and thrust bearing can now be easily lifted out.

Replacing the turntable

1. Slip the turntable over the lower end of the centerpost until it comes against the stop or ears. (Figure 9.)
2. Place the thrust bearing and washers on the bottom end of the centerpost and place the centerpost and turntable in position as shown. (Figure 9.)
3. Turn the spindle so the step in the centerpost is away from the record support. (Figure 11.)
4. Tighten the two mounting screws. (Figure 10.)

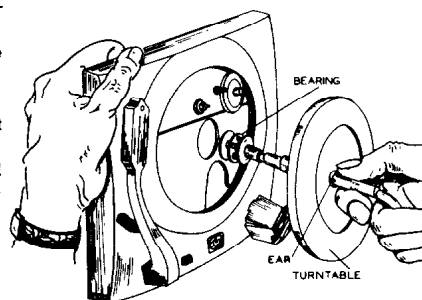

Figure 9

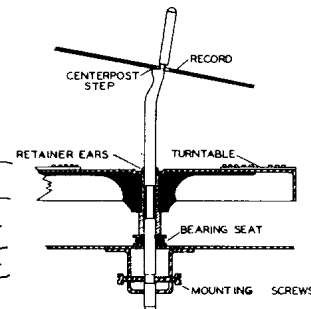

Figure 10

Turntable centering

If for any reason the sub-assembly had been removed from the motorboard it is necessary to re-center the turntable.

1. Loosen the three sub-assembly mounting bolts. (Figure 12.)
2. Place the turntable in place with the center post extending down through the mounting as shown. (It is not necessary to have the thrust bearing in place for this operation.) (Figure 9.)
3. Center the turntable in respect to the recess in the motorboard by shifting the position of the sub-assembly slightly. (Figure 11.)
4. Tighten the nut on the end of the square head mounting bolt. (Figure 12.)
5. Remove the turntable and tighten the other two mounting bolts. (Figure 12.)

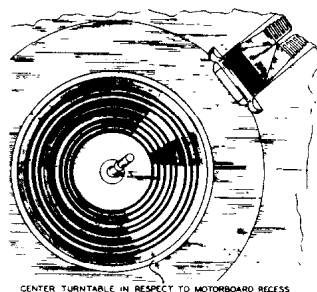

Figure 11

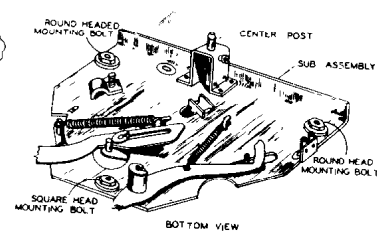

Figure 12

MANUAL OF 1949 MOST-OFTEN NEEDED RADIO DIAGRAMS

RP-178 SERIES

CYCLE OF OPERATION

Function	Explanation	
Lift and slide the record support to 10 or 12 inch position as desired	<ol style="list-style-type: none"> 1. Record support locks in position and at the same time the record push cam and gear rotates and assumes a position as required for 10- or 12-inch records. 	
Operator Place the stack of records over the center post	<ol style="list-style-type: none"> 1. The lower record of the stack is sitting on the step in the centerpost, and the edge is resting on the record support. 	
	Push reject button	<ol style="list-style-type: none"> 1. The end of the reject button extending through the motorboard contacts and moves ratchet lever. 2. Ratchet lever unlatches stud which is mounted on cycling carriage. This allows the tension spring to pull the cycling cam against the rotating knurled roller and start cycle.
Automatic Cycle Tone arm rises and moves out	<ol style="list-style-type: none"> 1. As the cycling cam rotates the small roller on the tone arm director lever follows the channel in the cam and in so doing pulls on the cable connected to the tone arm. 2. The hole in the motorboard provides a guide for the tone arm cable. It is so placed as to allow the cable to pull at an angle slightly off 90 degrees thus giving the necessary rising and outward motion of the tone arm. 3. The trip lever which is rigidly connected to the tone arm through the tone arm pivot shaft is moved out with the tone arm. 4. The tone arm return lever has moved out slightly ahead of the trip lever. The tone arm return lever together with the small latch assumes such a position so as to engage the stud on the trip lever and stabilize the tone arm in its outermost position. 	
	The record push cam together with the "step" in the centerpost separates the lower record of the stack allowing it to drop to the turntable	<ol style="list-style-type: none"> 1. While the cycling cam is continuing to rotate, the rack lever is being pushed outward by the small eccentric elevated cam, with which it is engaged. 2. The teeth in the rack lever being engaged with record push cam gear, converts the sliding action of the rack lever into a rotary motion. 3. The rotary motion of the record push cam pushes the record off the step in the centerpost.

MANUAL OF 1949 MOST-OFTEN-NEEDED RADIO DIAGRAMS

RP-178 SERIES

CYCLE OF OPERATION

Function	Explanation
Tone arm moves in and lands on record	<ol style="list-style-type: none"> 1. As the cycling cam is returning to normal position, the tone arm director lever is gradually allowing a slack in the tone arm cable. 2. While the tone arm director lever is gradually allowing slack in cable, the tone arm return lever is tending to retain the tension on the cable by returning the tone arm to the landing position. 3. The distance the tone arm return lever travels, while moving the pickup in for landing, is determined by the contact between the tone arm locating lever and the stud on the tone arm return lever. 4. After the tone arm return lever has moved the tone arm to the landing position the tone arm director lever continues to move and allow enough slack in the cable so the pickup can sit down on the start of the record.
Sapphire moves into record groove. Record begins to play	<ol style="list-style-type: none"> 1. As the sapphire moves into the playing groove, the cycling cam becomes disengaged from the rotating knurled roller as the roller falls into the step in the cam. 2. The change cycle is completed as the stud on the cycling cam carriage becomes engaged with the ratchet lever. This engagement prevents the cycling cam from contacting the knurled roller, starting a new cycle.
The record plays	<ol style="list-style-type: none"> 1. After the playing of the record, the pickup moves into the eccentric groove. 2. The movement of the pickup in the eccentric groove causes the trip pawl to engage the ratchet lever starting a new cycle. (The mechanism plays one side of each record in the stack then repeats the playing of the last record until the pickup is manually placed on the rest or the power removed from the mechanism.)

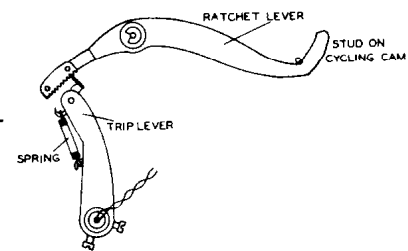
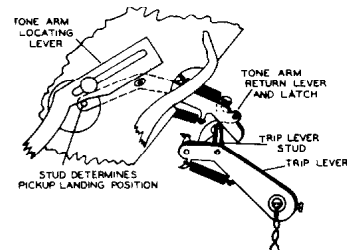
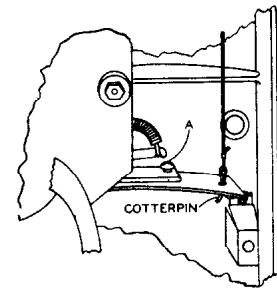

REPLACEMENT OF SAPPHIRE

Caution: Never bend the sapphire support wire.

Extreme care should be used when loosening the sapphire mounting nut so that the twisting motion does not break the crystal.

Remove the two screws holding the sapphire guard in place and remove guard. Remove the small nut and washer on the threaded shaft of the sapphire holder and gently push the shaft through the hole in the armature shaft until the sapphire holder assembly comes free.

Do not use force as the crystal may be broken.

Insert threaded shaft of replacement sapphire holder through armature shaft and replace the washer and nut. Make sure that the sapphire is in the correct position. Take hold at the lower end of the shaft with a pair of pliers while tightening the nut, being very careful so as not to strip the threads or break the crystal. Replace the sapphire guard, positioning it by means of the oversize screw slots. Make certain that the sapphire and its supporting wire are centered in the guard. Tighten the guard screws. Before using, check to see that the sapphire projects far enough (approx. .020) beyond the guard so that the guard will not strike the record. If necessary, bend the guard a little.

Note: Pickup pressure should be approximately 1 to 1 1/4 oz.

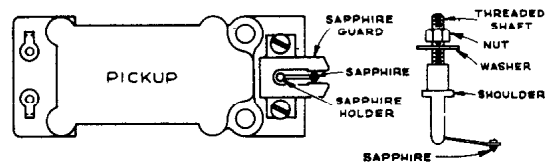

LUBRICATION

Motor

Motor is lubricated at factory to provide normal operation for a long period of time.

If it becomes necessary to lubricate, use SAE #10 motor oil to saturate the felt wicks on the motor bearings.

Main Bearing

Use STA-PUT #512 or SAE #30 motor oil.

Slides and Levers

Use STA-PUT #512.

115

MANUAL OF 1949 MOST-OFTEN-NEEDED RADIO DIAGRAMS

ILLUSTRATED SERVICE HINTS

RP-178 SERIES

Pickup Repeats Grooves

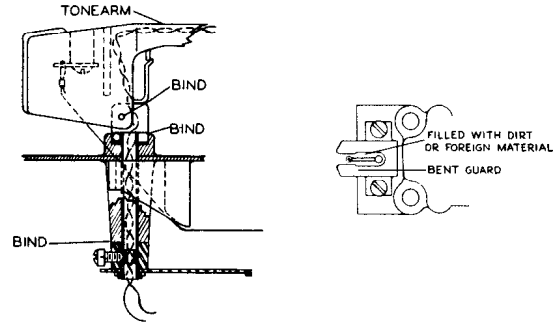
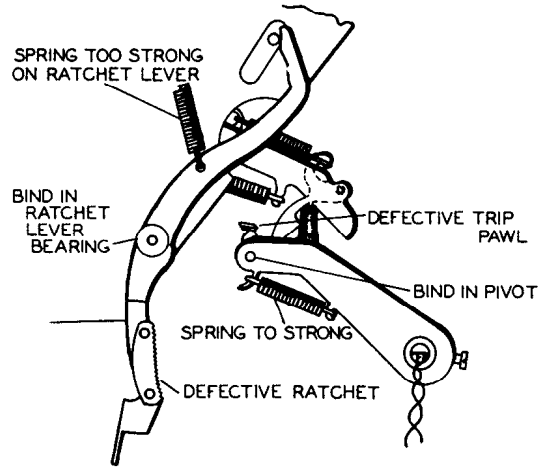

Continuous Tripping

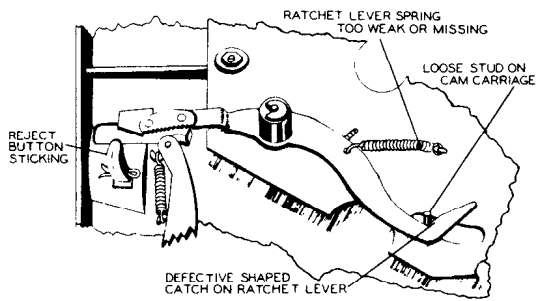

Premature Tripping

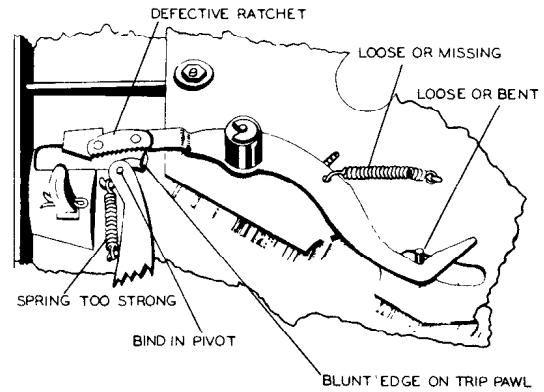

Failure To Trip or Go Into Cycle

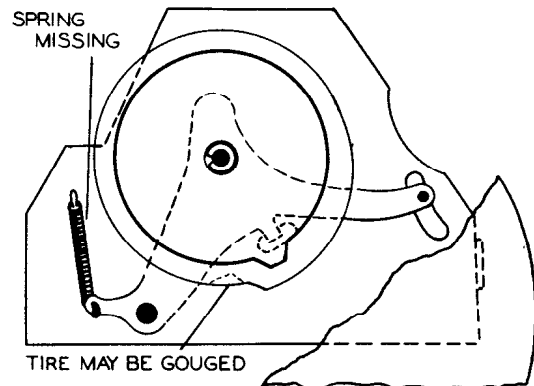
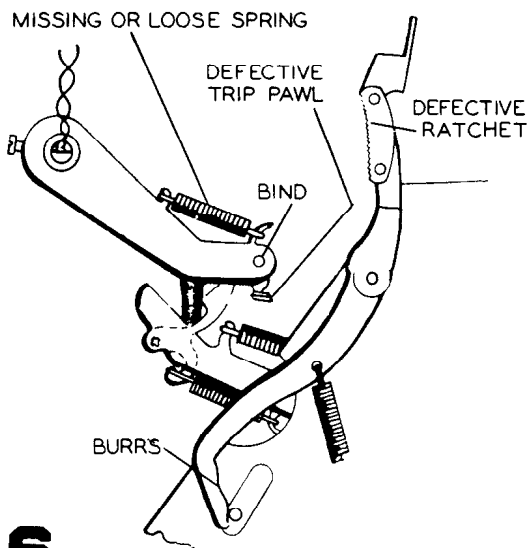

MANUAL OF 1949 MOST-OFTEN-NEEDED RADIO DIAGRAMS

RP-178 SERIES

ILLUSTRATED SERVICE HINTS

Changer Will Not Complete Cycle

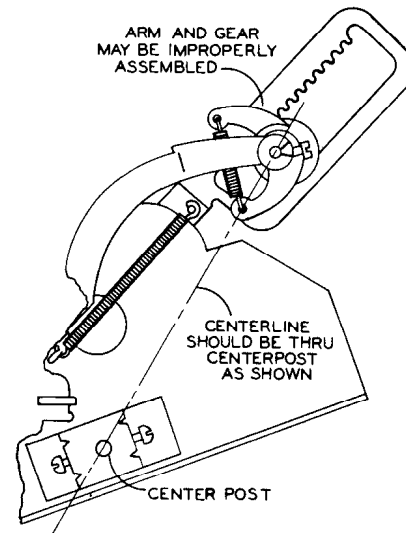
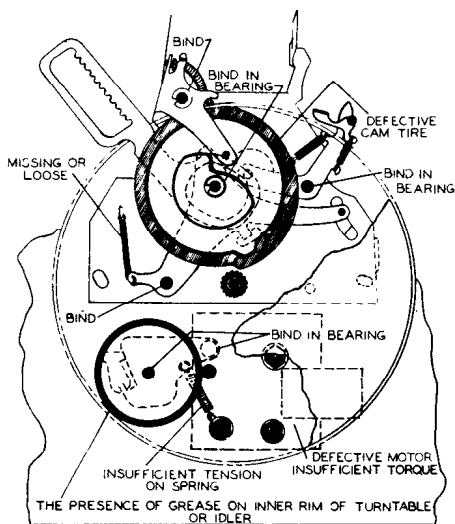

Records Do Not Separate or Drop Properly

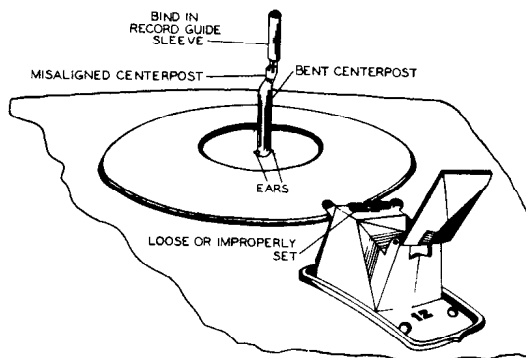

Distorted Output

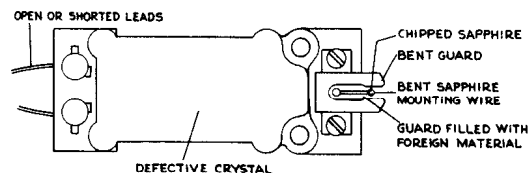

"Wow" or Slow Turntable Speed

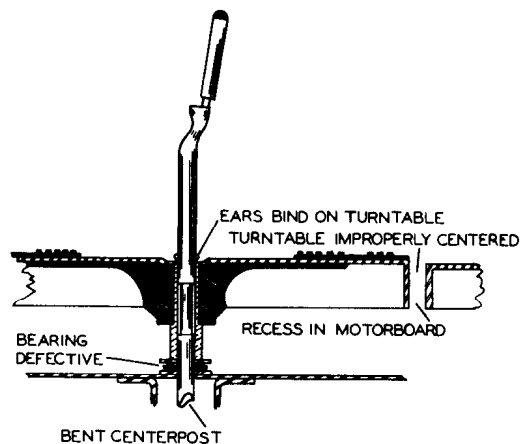
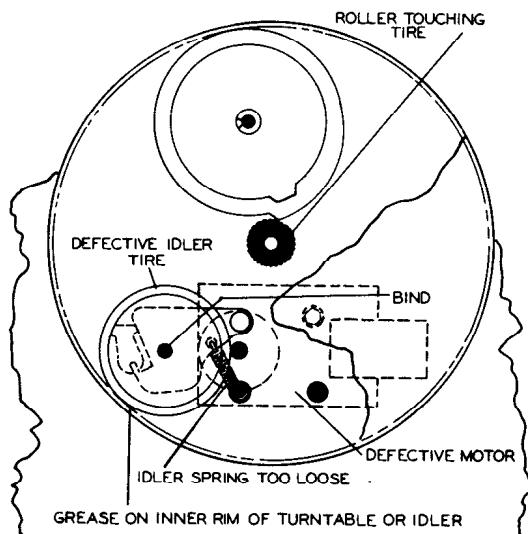

MANUAL OF 1949 MOST-OFTEN-NEEDED RADIO DIAGRAMS

RP-178 SERIES

ILLUSTRATED SERVICE HINTS

Improper Pickup Landing

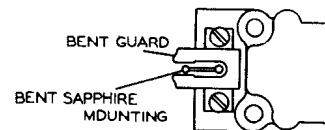
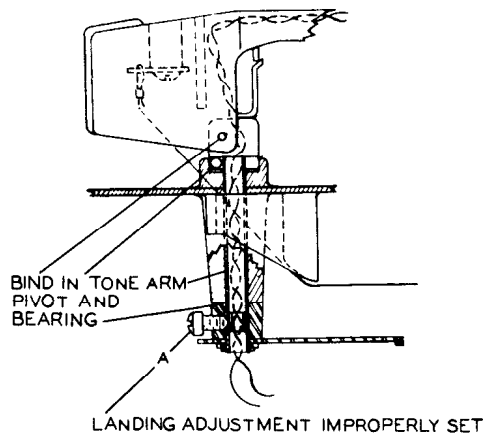
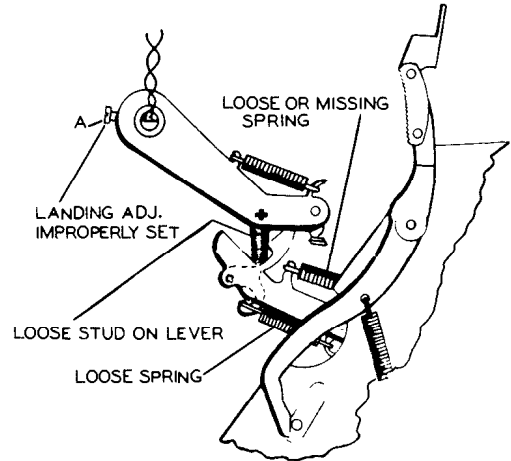
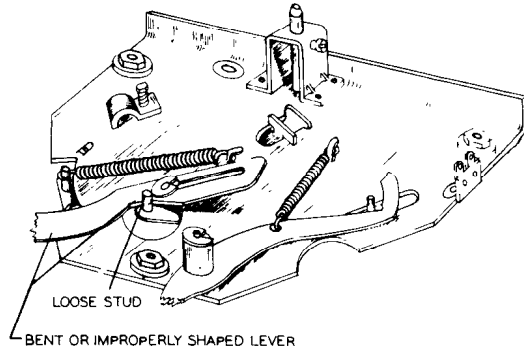

Rumble

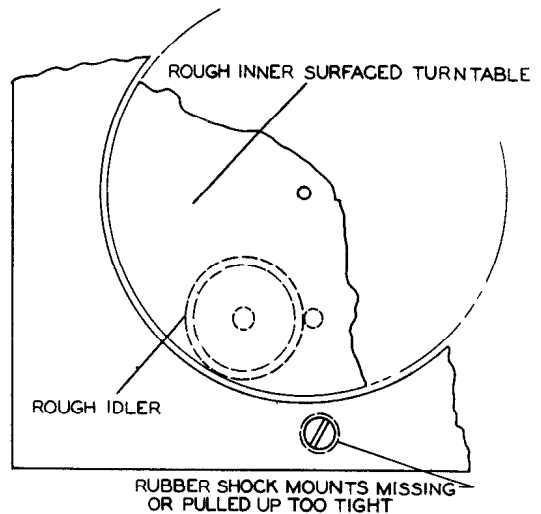
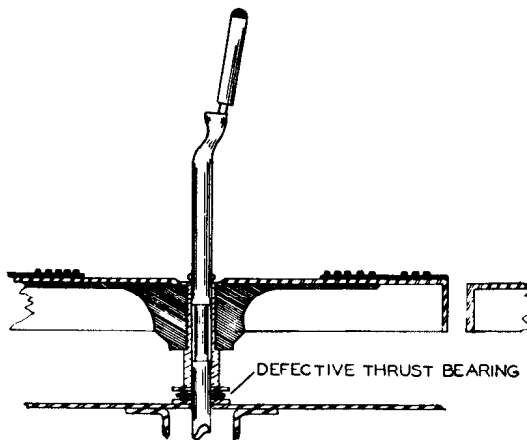

MANUAL OF 1949 MOST-OFTEN-NEEDED RADIO DIAGRAMS

Silvertone

* - PART OF T2

TUBE SOCKETS ARE VIEWED FROM UNDERSIDE OF CHASSIS. VOLTAGE READINGS SHOWN AT SOCKET PRONGS ARE TO NEGATIVE "B" AND ARE TAKEN WITH PHONO-RADIO SWITCH IN RADIO POSITION AND WITH LINE VOLTAGE AT 117 VOLTS. WHERE NO READING IS GIVEN, THE VOLTAGE IS ZERO OR TOO LOW TO READ. VOLTAGE READINGS ARE TAKEN WITH A VOLTMETER HAVING A RESISTANCE OF ONE THOUSAND OHMS PER VOLT. THE GAIN PER STAGE VALUES AS NOTED ABOVE, ARE APPROXIMATE VALUES FOR AN AVERAGE INPUT, RATHER THAN AN ABSOLUTE VALUE. A 0.1 MFD. DUMMY IS USED FOR ALL MEASUREMENTS. INPUT SHALL BE KEPT AT THE LOWEST LEVEL NECESSARY TO MAINTAIN A STANDARD OUTPUT OF 50 MILLIWATTS WITH THE VOLUME CONTROL FULLY ON. NOTE: THE TYPE OF EQUIPMENT USED, THE HANDLING OF THE PROBES, THE ACCURACY OF ALIGNMENT, ETC., CAN AFFECT THE MEASUREMENTS.

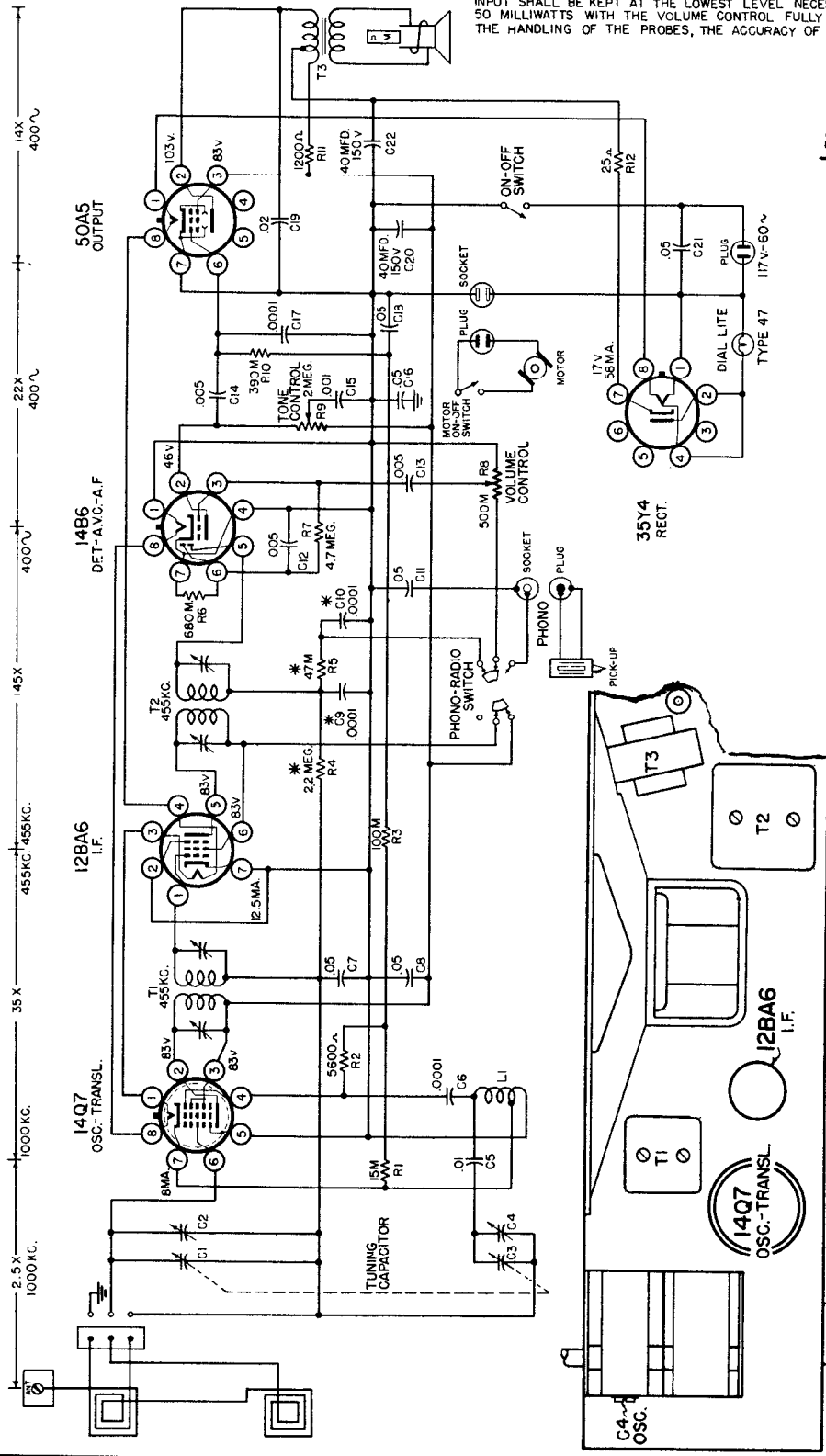

Sears, Roebuck & Co.

Catalog No. 8080

Chassis 101.852

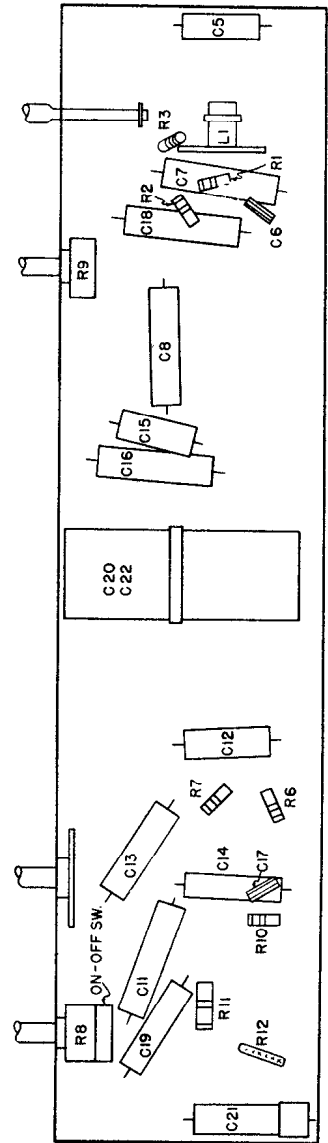

MANUAL OF 1949 MOST-OFTEN-NEEDED RADIO DIAGRAMS

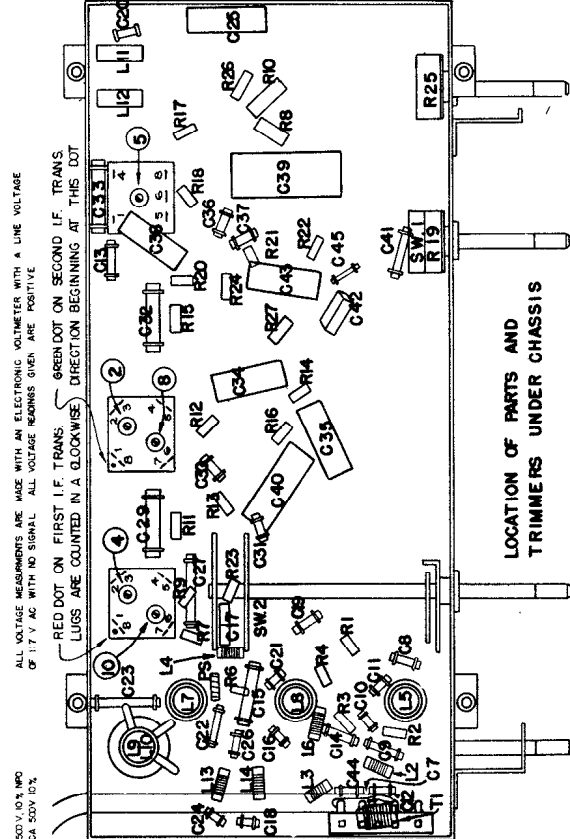
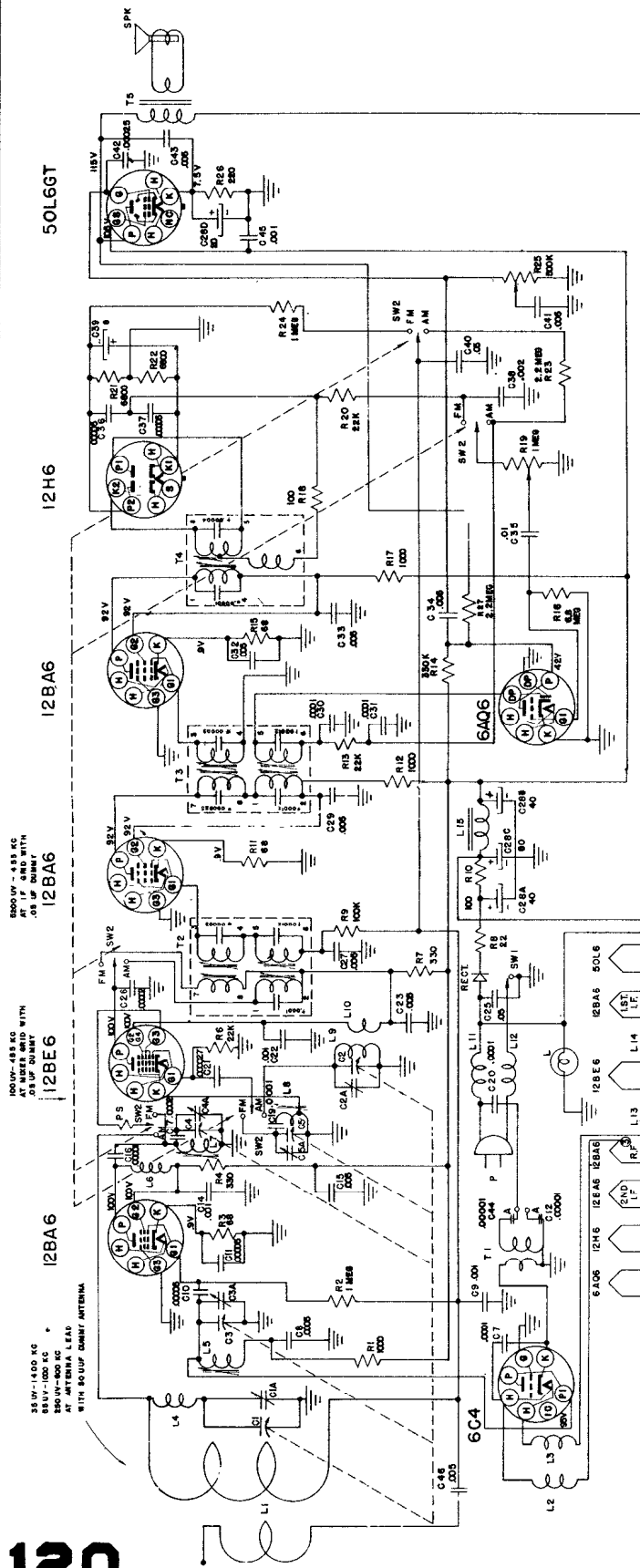

Sears, Roebuck & Co.
 Catalog No. 8020
 Chassis 132.841
 FM I.F. 10.7 MC.
 AM I.F. 455 KC.

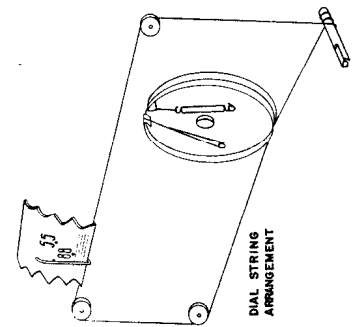

MANUAL OF 1949 MOST-OFTEN-NEEDED RADIO DIAGRAMS

Sears, Roebuck & Co. Catalog Nos. 8107A, 8108, 8108A
Chassis 101.851

Silvertone

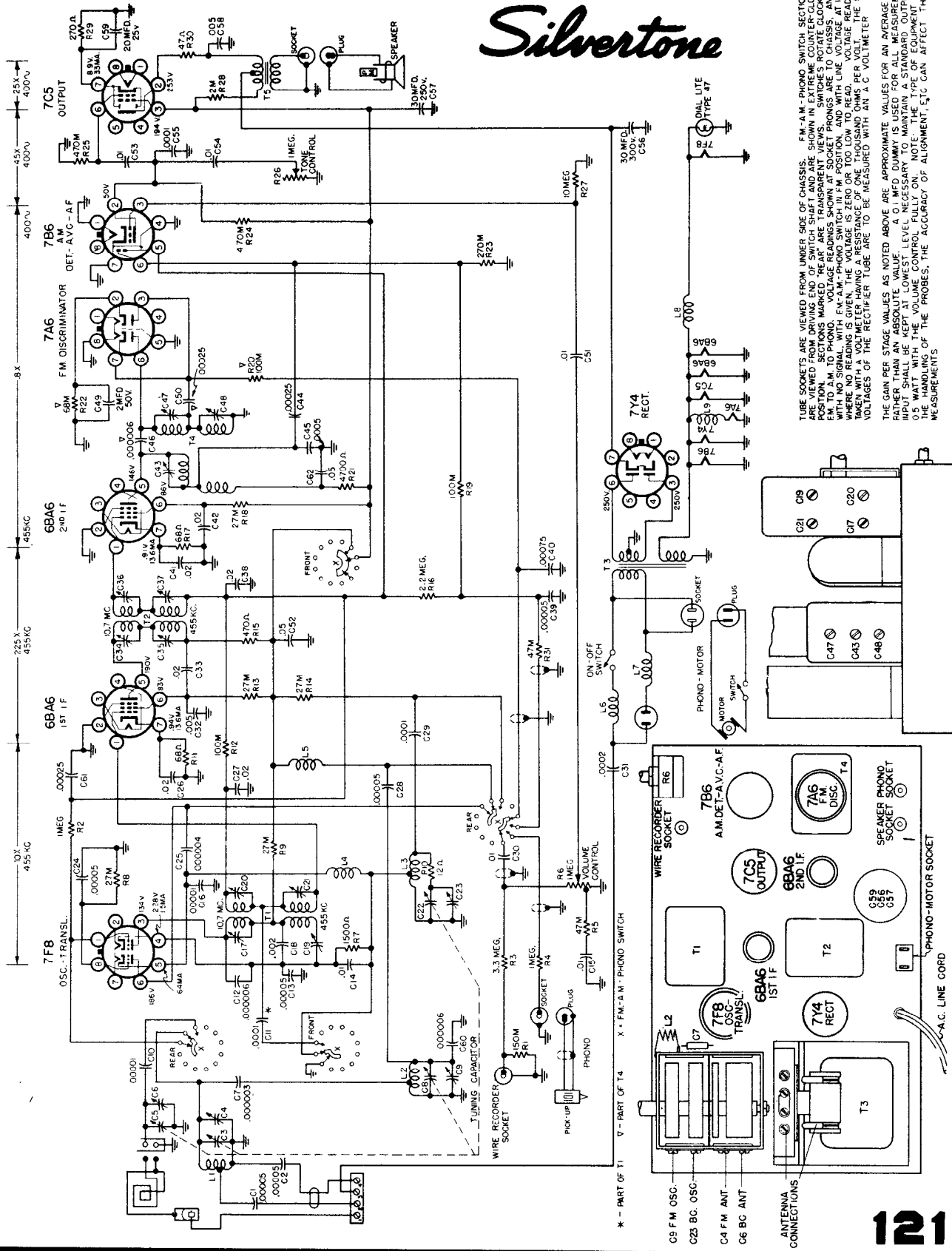

TUBE SOCKETS ARE VIEWED FROM INNER SIDE OF CHASSIS. FM-A.M. PHONO SWITCH SECTIONS SHOWN IN EXTREME POSITION. SECTIONS MARKED "REAR" ARE TRANSPARENT VIEWS. SWITCHES ROTATE CLOCKWISE FROM POSITION SHOWN TO A.M. TO PHONO. VOLTAGE READINGS SHOWN AT SOCKET PRONGS ARE TO CHASSIS, AND ARE TAKEN WITH NO SIGNAL, WITH F.M.-A.M. PHONO SWITCH IN F.M. POSITION, AND WITH LINE VOLTAGE AT 117 VOLTS. TAKE MEASUREMENTS WITH VOLTAGE MEASURING INSTRUMENTS HAVING A RESISTANCE OF ONE THOUSAND OHMS PER VOLT. THE VOLTAGES OF THE RECTIFIER TUBE ARE TO BE MEASURED WITH AN A.C. VOLTMETER.

THE GAIN PER STAGE VALUES AS NOTED ABOVE ARE APPROXIMATE VALUES FOR AN AVERAGE SET. INPUT SIGNALS ARE KEPT AT THE LOWEST LEVEL NECESSARY TO MAINTAIN A STANDARD OUTPUT OF 0.5 WATT WITH THE VOLUME CONTROL FULLY ON. NOTE: THE TYPE OF EQUIPMENT USED, THE HANDLING OF THE PROBES, THE ACCURACY OF ALIGNMENT, ETC CAN AFFECT THE MEASUREMENTS.

* - PART OF T1 7 - PART OF T4 X - F.M.-A.M. PHONO SWITCH

MANUAL OF 1949 MOST-OFTEN-NEEDED RADIO DIAGRAMS

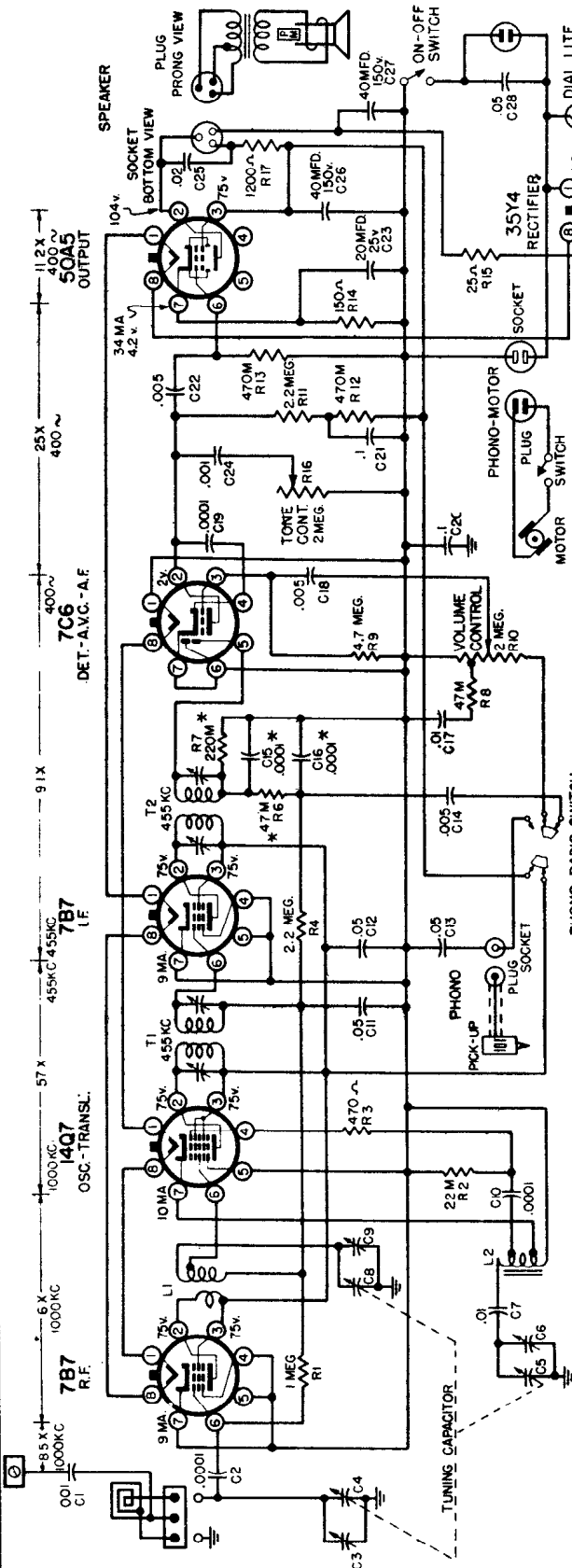

* - PART OF T2

TUBE SOCKETS ARE VIEWED FROM UNDER SIDE OF CHASSIS. VOLTAGE READINGS SHOWN AT SOCKET PRONGS ARE TO NEG. "B", AND ARE TAKEN WITH NO SIGNAL, WITH PHONO-RADIO SWITCH IN RADIO POSITION, AND WITH LINE VOLTAGE AT 117 VOLTS. WHERE NO READING IS GIVEN THE VOLTAGE IS ZERO OR TOO LOW TO READ

THE GAIN PER STAGE VALUES AS NOTED ABOVE ARE APPROXIMATE VALUES FOR AN AVERAGE STAGE, RATHER THAN AN ABSOLUTE VALUE. A 0.1 MFD DUMMY IS USED FOR ALL MEASUREMENTS EXCEPT FOR THE ANTENNA WHERE A 200 MMFD DUMMY IS USED. USED INPUT SHALL BE KEPT AT THE LOWEST LEVEL NECESSARY TO MAINTAIN A STANDARD OUTPUT OF 50 MILLIWATTS WITH THE VOLUME CONTROL FULLY ON

Sears, Roebuck & Co.
Catalog Nos. 8083, 8084, 7080, 8101
Chassis 101.809-1A, -1B, -2, -3C

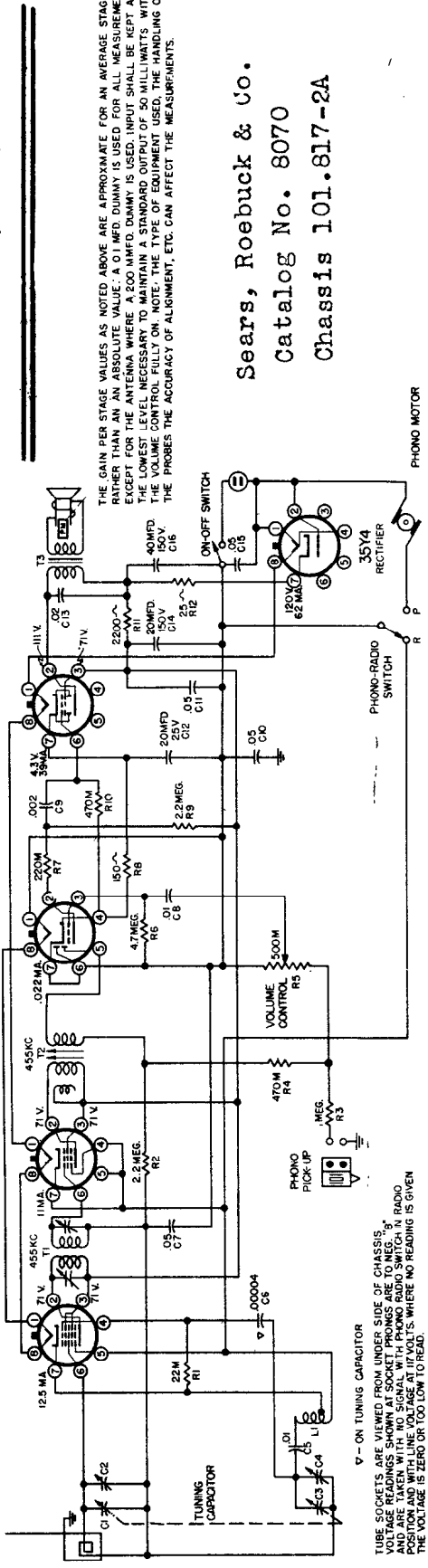

THE GAIN PER STAGE VALUES AS NOTED ABOVE ARE APPROXIMATE FOR AN AVERAGE STAGE, RATHER THAN AN ABSOLUTE VALUE. A 0.1 MFD DUMMY IS USED FOR ALL MEASUREMENTS EXCEPT FOR THE ANTENNA WHERE A 200 MMFD DUMMY IS USED. INPUT SHALL BE KEPT AT THE LOWEST LEVEL NECESSARY TO MAINTAIN A STANDARD OUTPUT OF 50 MILLIWATTS WITH THE VOLUME CONTROL FULLY ON. NOTE: THE TYPE OF EQUIPMENT USED, THE HANDLING OF THE PROBES THE ACCURACY OF ALIGNMENT, ETC. CAN AFFECT THE MEASUREMENTS.

Sears, Roebuck & Co.
Catalog No. 8070
Chassis 101.817-2A

MANUAL OF 1949 MOST-OFTEN-NEEDED RADIO DIAGRAMS

Silverstone

Sears, Roebuck & Co.
 Catalog Nos. 8153, 8153A
 Chassis 109.635, 109.635-1

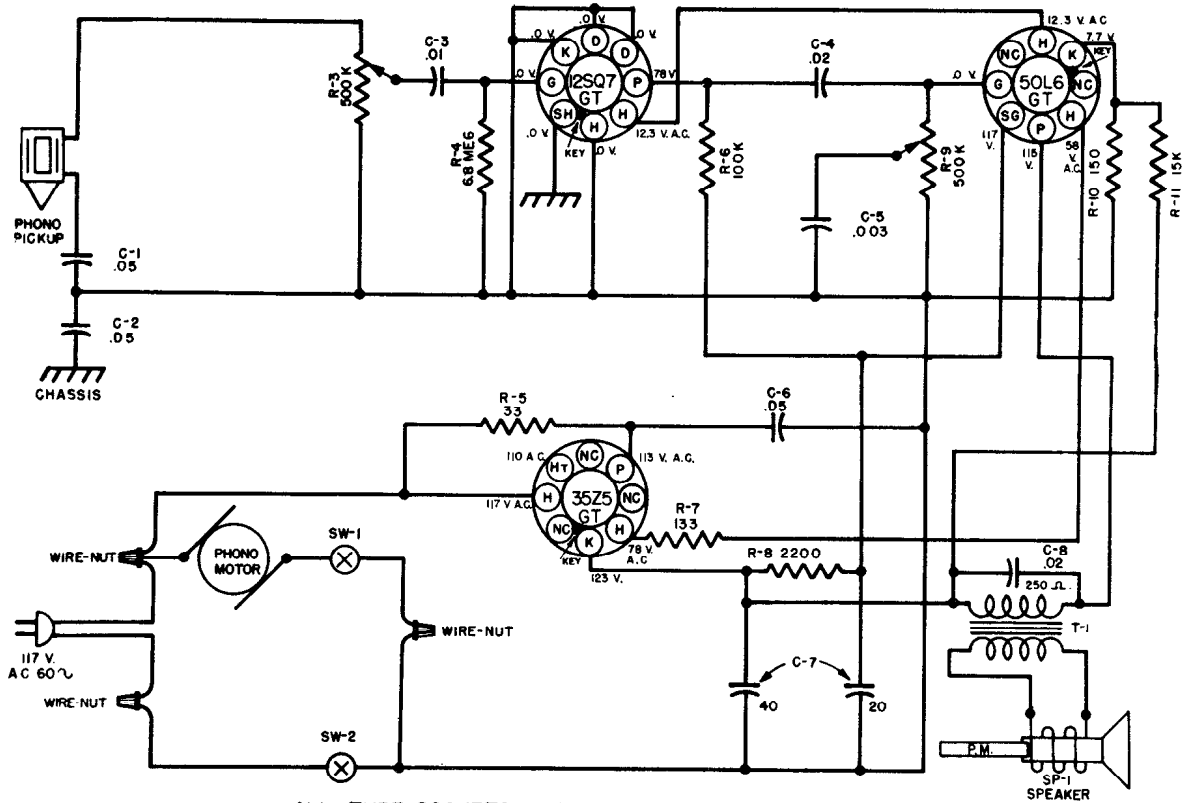

ALL TUBE SOCKETS SHOWN FROM PIN END VIEW

NOTE: ALL DC VOLTAGES MEASURED WITH A 1000 OHM PER VOLT METER FROM B- TO SOCKET CONTACT INDICATED. ALL VOLTAGES ARE POSITIVE DC UNLESS OTHERWISE MARKED. VOLUME CONTROL FULL ON. ZERO SIGNAL INPUT. TONE CONTROL IN CLOCKWISE POSITION. LINE VOLTAGE 117 VOLTS AC. RESISTANCE VALUES ARE IN OHMS UNLESS OTHERWISE NOTED. "K" EQUALS 1000 OHMS, "MEG." EQUALS 1,000,000 OHMS. CAPACITY VALUES ARE IN MICROFARADS UNLESS OTHERWISE NOTED.

Bottom View — Parts Layout

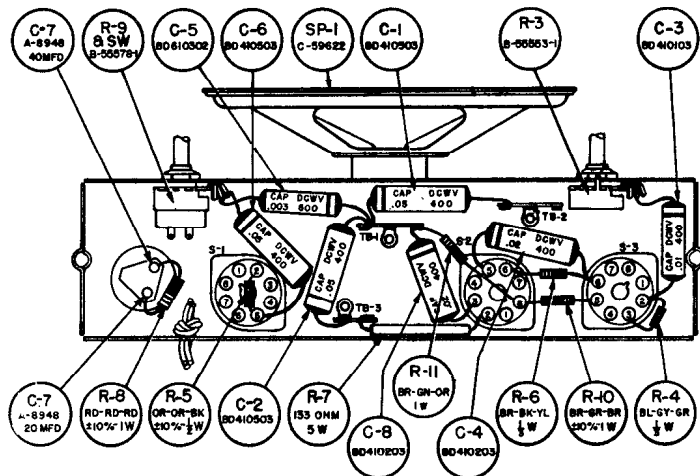

Tube Layout

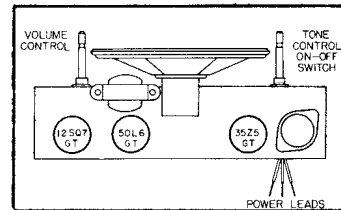

Note: Only difference between Chassis 109.635 and 109.635-1 is, output transformer on chassis 109.635 is located directly behind speaker instead of as shown above.

MANUAL OF 1949 MOST-OFTEN-NEEDED RADIO DIAGRAMS

Silvertone

SEARS, ROEBUCK & CO.
 Catalog Nos. 8102, 8102B, 8102B, Chassis 101.814-2B
 (Catalog Nos. 8102A, 8086, -A, -B are similar)

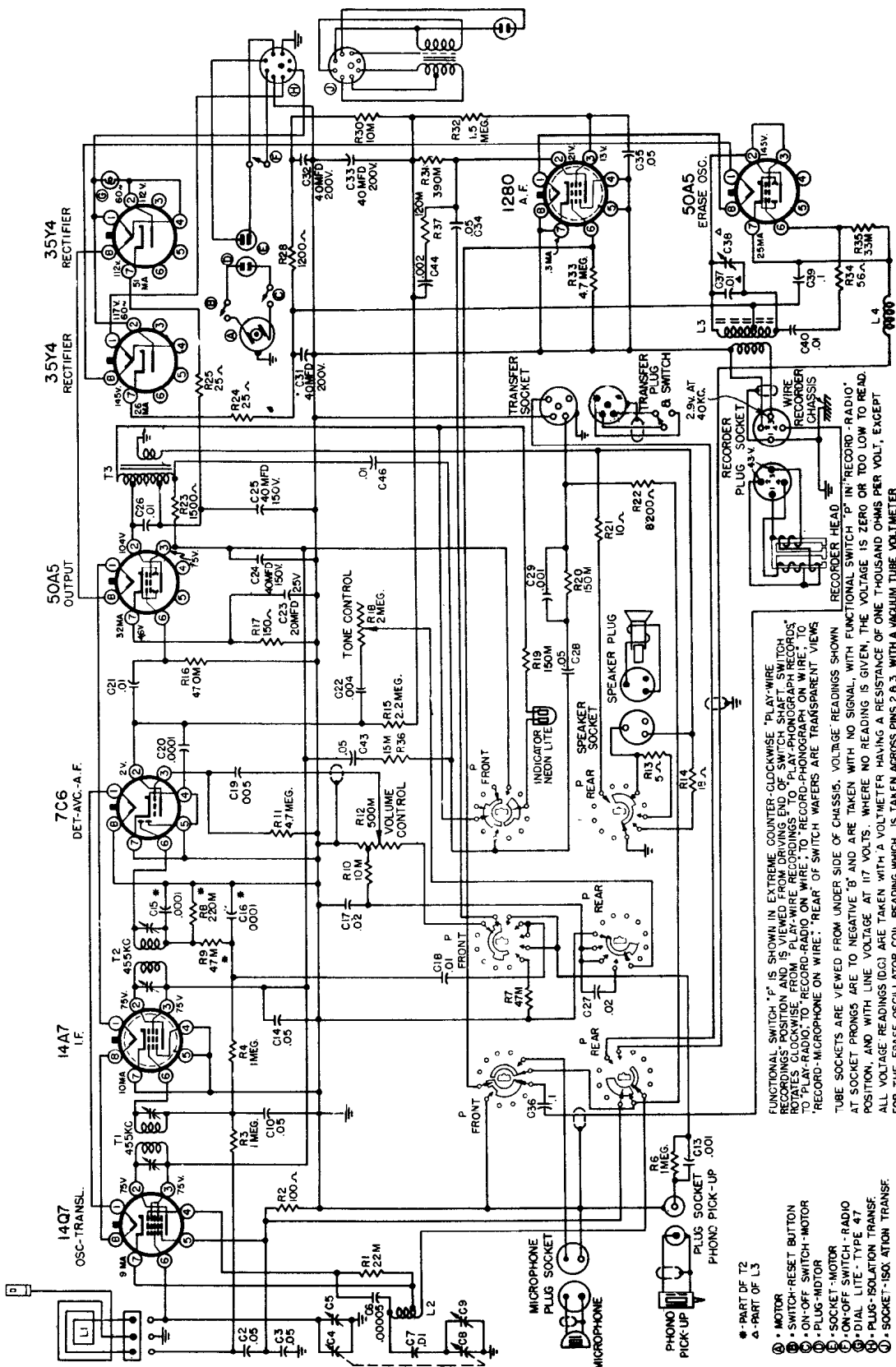

FUNCTIONAL SWITCH "P" IS SHOWN IN EXTREME COUNTER-CLOCKWISE "PLAY-WIRE RECORDINGS" POSITION AND IS VIEWED FROM DRIVING END OF SWITCH SHAFT. SWITCH ROTATES CLOCKWISE FROM "PLAY-WIRE RECORDINGS" TO "PLAY-PHONOGRAPHS RECORDS" TO "PLAY-RADIO", TO "RECORD-RADIO ON WIRE", TO "RECORD-PHONOGRAPHS ON WIRE", TO "RECORD-MICROPHONE ON WIRE". REAR OF SWITCH WAFERS ARE TRANSPARENT VIEWS.

TUBE SOCKETS ARE VIEWED FROM UNDER SIDE OF CHASSIS. VOLTAGE READINGS SHOWN AT SOCKET PRONGS ARE TO NEGATIVE "B" AND ARE TAKEN WITH NO SIGNAL IN "RECORD-RADIO" POSITION, AND WITH LINE VOLTAGE AT 117 VOLTS. WHERE NO READING IS GIVEN, THE VOLTAGE IS ZERO OR TOO LOW TO READ. ALL VOLTAGE READINGS (DC) ARE TAKEN WITH A VOLTMETER HAVING A RESISTANCE OF ONE THOUSAND OHMS PER VOLT, EXCEPT FOR THE ERASE OSCILLATOR COIL READING WHICH IS TAKEN ACROSS PINS 2 B 3 WITH A VACUUM TUBE VOLTMETER.

- - PART OF T2
- ▲ - PART OF L3
- ⊙ - MOTOR
- ⊕ - SWITCH-RESET BUTTON
- ⊖ - ON-OFF SWITCH-MOTOR
- ⊗ - PLUG-MIDTOR
- ⊘ - SOCKET-MOTOR
- ⊙ - ON-OFF SWITCH-RADIO
- ⊕ - DIAL LITE - TYPE 47
- ⊖ - PLUG-ISOLATION TRANSF.
- ⊗ - SOCKET-ISOLATION TRANSF.

SCHEMATIC DIAGRAM FOR 101.814-2B

MANUAL OF 1949 MOST-OFTEN-NEEDED RADIO DIAGRAMS

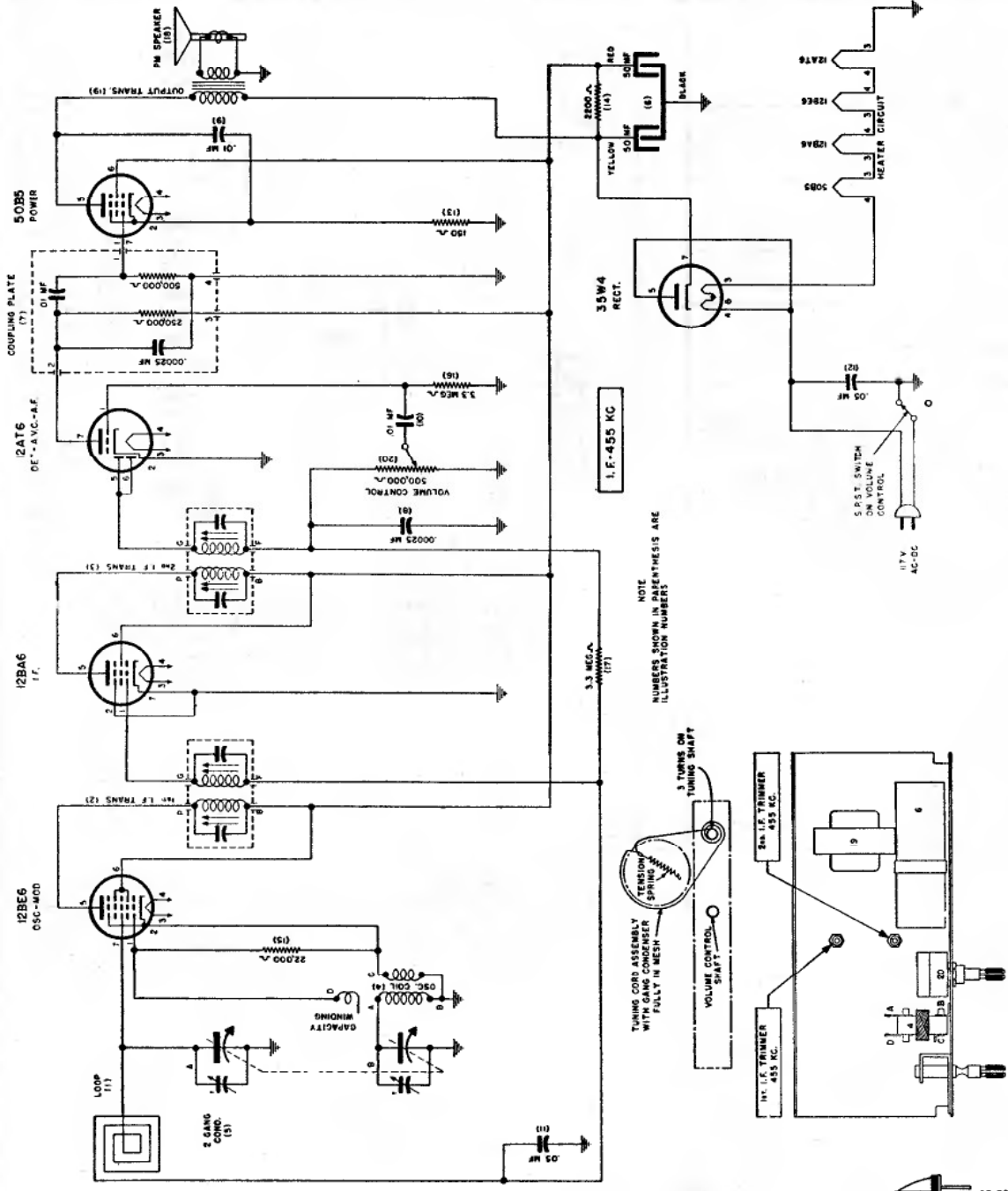

NOTE
NUMBERS SHOWN IN PARENTHESES ARE
ILLUSTRATION NUMBERS

MODELS 329-W, 329-I, 329-R
SERIES "B"

Sentinel Radio

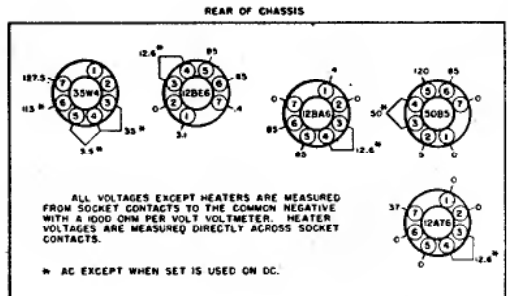

ALL VOLTAGES EXCEPT HEATERS ARE MEASURED FROM SOCKET CONTACTS TO THE COMMON NEGATIVE WITH A 100 OHM PER VOLT VOLTMETER. HEATER VOLTAGES ARE MEASURED DIRECTLY ACROSS SOCKET CONTACTS.

* AC EXCEPT WHEN SET IS USED ON DC.

VOLTAGE TABLE
(BOTTOM VIEW OF CHASSIS)

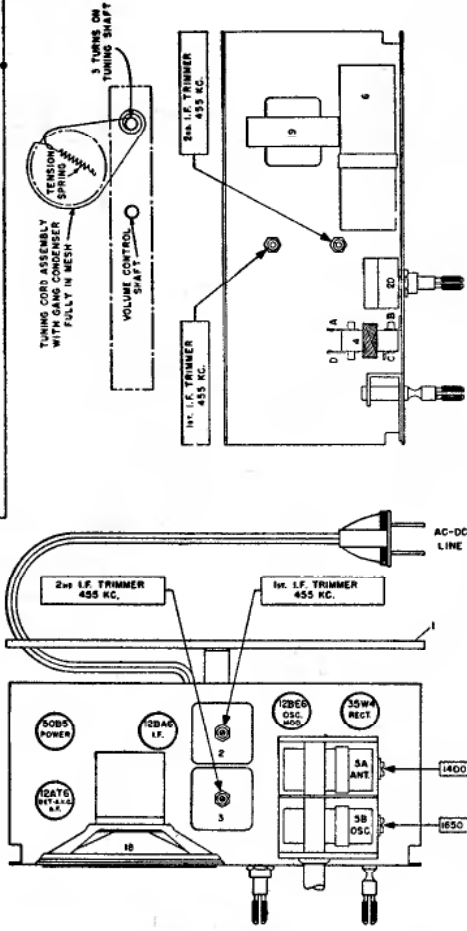

MANUAL OF 1949 MOST-OFTEN-NEEDED RADIO

Sentinel Radio

MODELS
314W, 314-I, and 314E
1U-314W, 1U-314-I, and 1U-314E

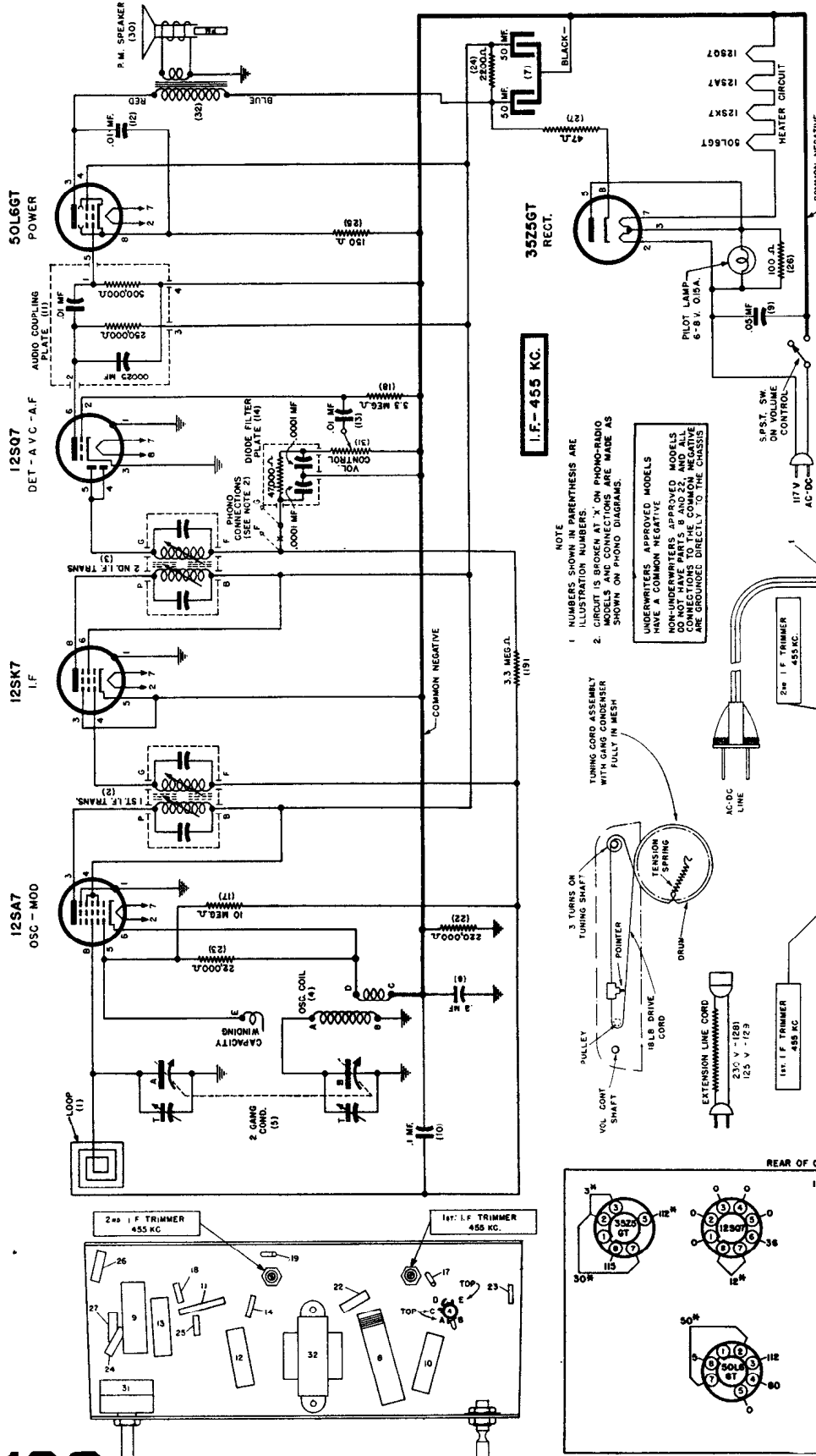

126

MANUAL OF 1949 MOST-OFTEN-NEEDED RADIO DIAGRAMS

Sentinel Radio -- Model 323K

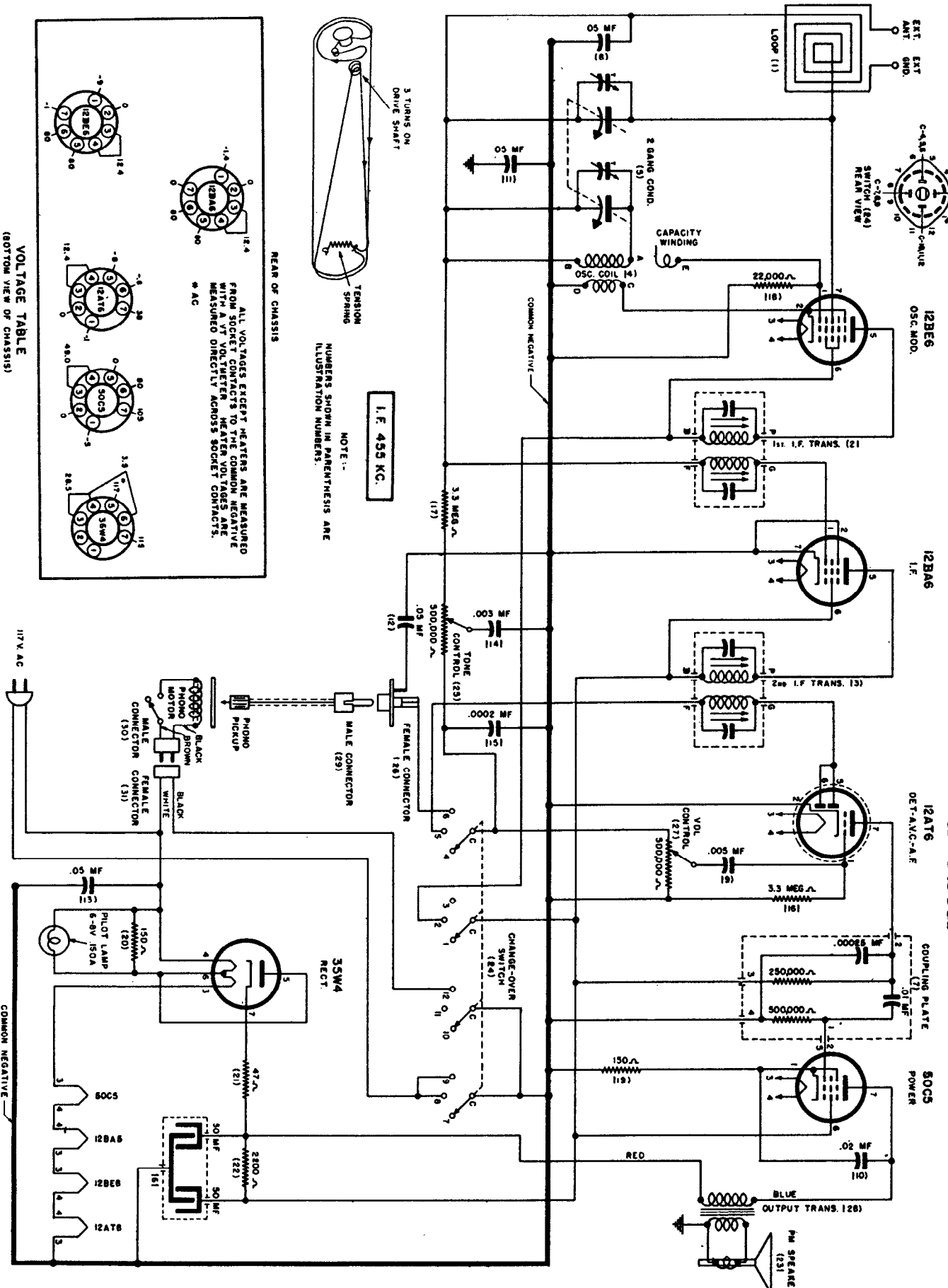

VOLTAGE TABLE

(BOTTOM VIEW OF CHASSIS)

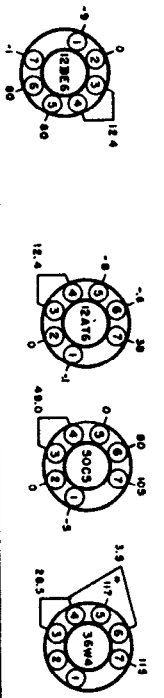

ALL VOLTAGES EXCEPT HEATERS ARE MEASURED FROM SOCKET CONTACTS TO THE COMMON NEGATIVE FROM SOCKET CONTACTS TO THE COMMON NEGATIVE MEASURED DIRECTLY ACROSS SOCKET CONTACTS.

ALIGNMENT

(C) Couple test oscillator to receiver loop by: (1) make loop consisting of 5 to 10 turns of No. 20 to No. 30 size wire, wound on a 2" or 3" form; (2) connect this loop across output of test oscillator; (3) place test oscillator across rear radio loop.

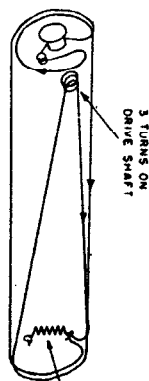

NOTE:-- NUMBERS SHOWN IN PARENTHESES ARE ILLUSTRATION NUMBERS.

1. F. 455 KC.

ALIGNMENT (C) Couple test oscillator to receiver loop by: (1) make loop consisting of 5 to 10 turns of No. 20 to No. 30 size wire, wound on a 2" or 3" form; (2) connect this loop across output of test oscillator; (3) place test oscillator loop near radio loop. **BE SURE THAT NEITHER LOOP MOVES WHILE ALIGNING.**

TEST OSCILLATOR

Steps	Set receiver dial to:	Adjust test oscillator frequency to:	Use dummy antenna in series with output of test oscillator consisting of:	Attach output of test oscillator to:	Refer to parts layout diagram for location of trimmers mentioned below:
1	Any point where no interfering signal is received	455 K. C.	.02 MFD. See Paragraph (C) Above	High side to rear stator plates of tuning condenser. Low side to frame of condenser through a .02 Mfd. blocking condenser.	Adjust each of the second I. F. transformer trimmers for maximum output—then adjust each of the first I. F. trimmers for maximum output.
2	Exactly 1650 K. C.	Exactly 1650 K. C.	See Paragraph (C) Above	See Paragraph (C) Above	Adjust 1650 K. C. oscillator trimmer for maximum output.
3	Approx. 1400 K. C.	Approx. 1400 K. C.	See Paragraph (C) Above	See Paragraph (C) Above	Adjust 1400 K. C. antenna trimmer for maximum output.

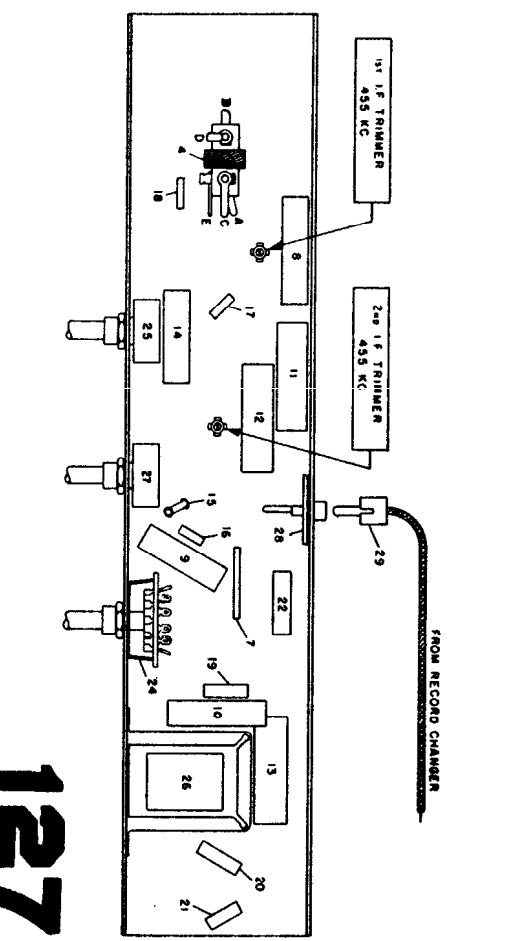
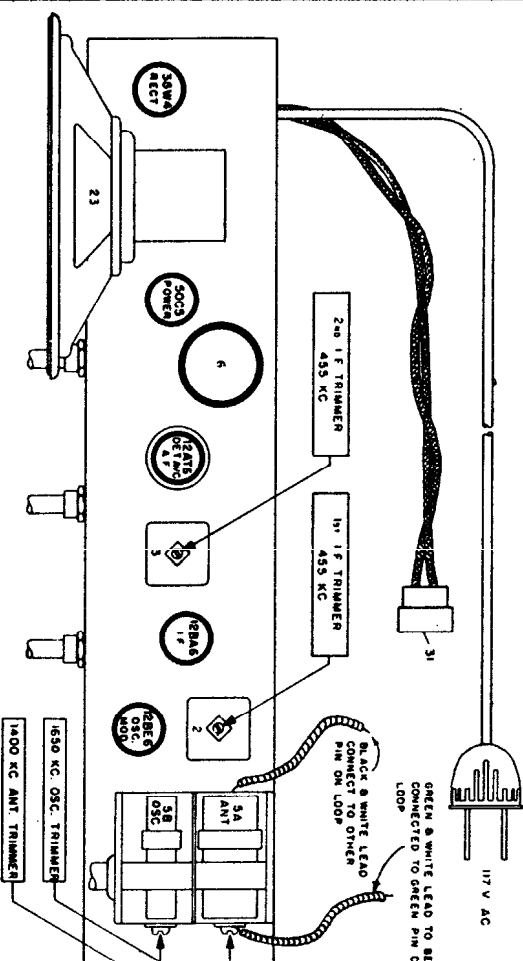

MANUAL OF 1949 MOST-OFTEN-NEEDED RADIO DIAGRAMS

Sonora

Clear as a Bell

Model 102

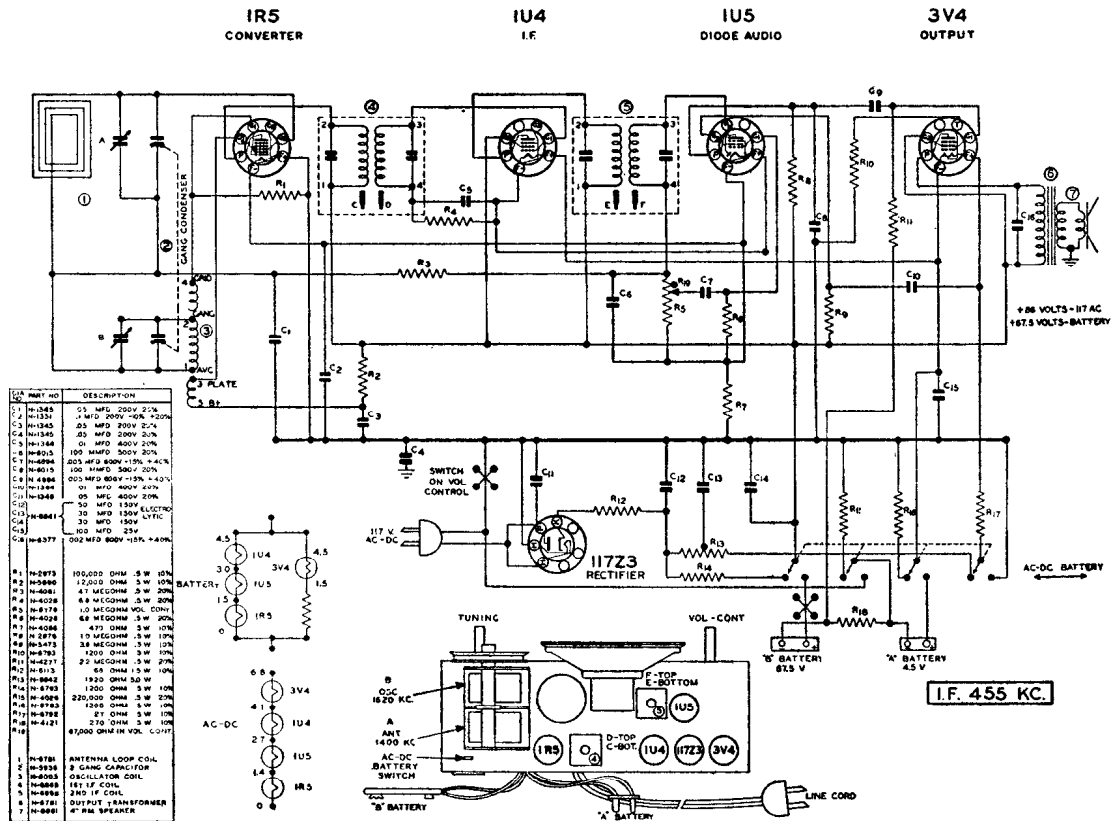

ALIGNMENT PROCEDURE

GENERAL DATA. The alignment of this receiver requires the use of a test oscillator that will cover the frequencies of 455, 600, 1400 and 1620 KC and an output meter to be connected across the primary or secondary of the output transformer. If possible, all alignments should be made with the volume control on maximum and the test oscillator output as low as possible to prevent the AVC from operating and giving false readings.

CORRECT ALIGNMENT PROCEDURE. The intermediate frequency (I.F.) stages should be aligned properly as the first step. After the I.F. transformers have been properly adjusted and peaked, the broadcast band should be adjusted.

I.F. ALIGNMENT: Remove the chassis and batteries from the cabinet and remove the bottom enclosure plate from the chassis. With the gang condenser set at minimum, adjust the test oscillator to 455 KC and connect the output to the grid of the first detector tube (IR5) through a .05 or .1 MFD condenser. The ground of the test oscillator should be connected to the buss. Align all four I.F. slugs to peak or maximum reading on the output meter. Each I.F. has an adjustment at the top and bottom of the can. The pecks on the slugs must be the ones farthest out of the coils.

I.F. ALIGNMENT: Place the cabinet on its face and open cabinet back to a 90° angle. Lay a board across the body of cabinet ahead of the loop. Replace the bottom chassis enclosure and set the chassis and batteries on the board so that they occupy the same relative position to the loop as they do in the cabinet. Care should be taken to have no iron or other metal near the loop.

Connect the test oscillator to a dummy loop which can be made by coiling 2 turns of hookup wire about 6" in diameter. Place this dummy loop about a foot from the loop on the receiver and in the same plane as the receiver loop. With the gang condenser set at minimum capacity, set the test oscillator at 1620 KC. and adjust the oscillator (or 1620 KC trimmer) on the gang condenser. Next set the test oscillator at 1400 KC. and tune in the signal on the gang condenser. Adjust the antenna trimmer (or 1400 KC trimmer) for maximum signal. Next set the test oscillator at 600 KC. and tune in signal on condenser to check alignment of coils.

BATTERY. To operate this receiver on battery, it will first be necessary to insert one prong of power cord plug into the switch through the slot located at the lower left hand corner of the top of the Chassis Base.

Before installing new batteries or replacing old ones, turn the volume control to the extreme left or "OFF" position, then the following sequence should be followed. Attach the connector with the snap-on fasteners to the "B" battery (67 1/2 V.) and insert battery into left side of battery compartment as viewed from rear of cabinet so that the connector faces the rear of cabinet. Insert the prongs of the other battery connector into the socket of the "A" battery (4 1/2 V.) and place battery into cabinet so that the socket of the "A" battery faces the "B" battery.

This receiver will accommodate any of the batteries listed below:

Manufacturer	Manufacturer's Type Number
.....	"A" Battery 746
.....	"B" Battery 467
National Carbon	3H3
General Dry Battery	W45A
Ray-O-Vac	P83A
Energus Battery	G3
.....	XX45

MANUAL OF 1949 MOST-OFTEN-NEEDED RADIO DIAGRAMS

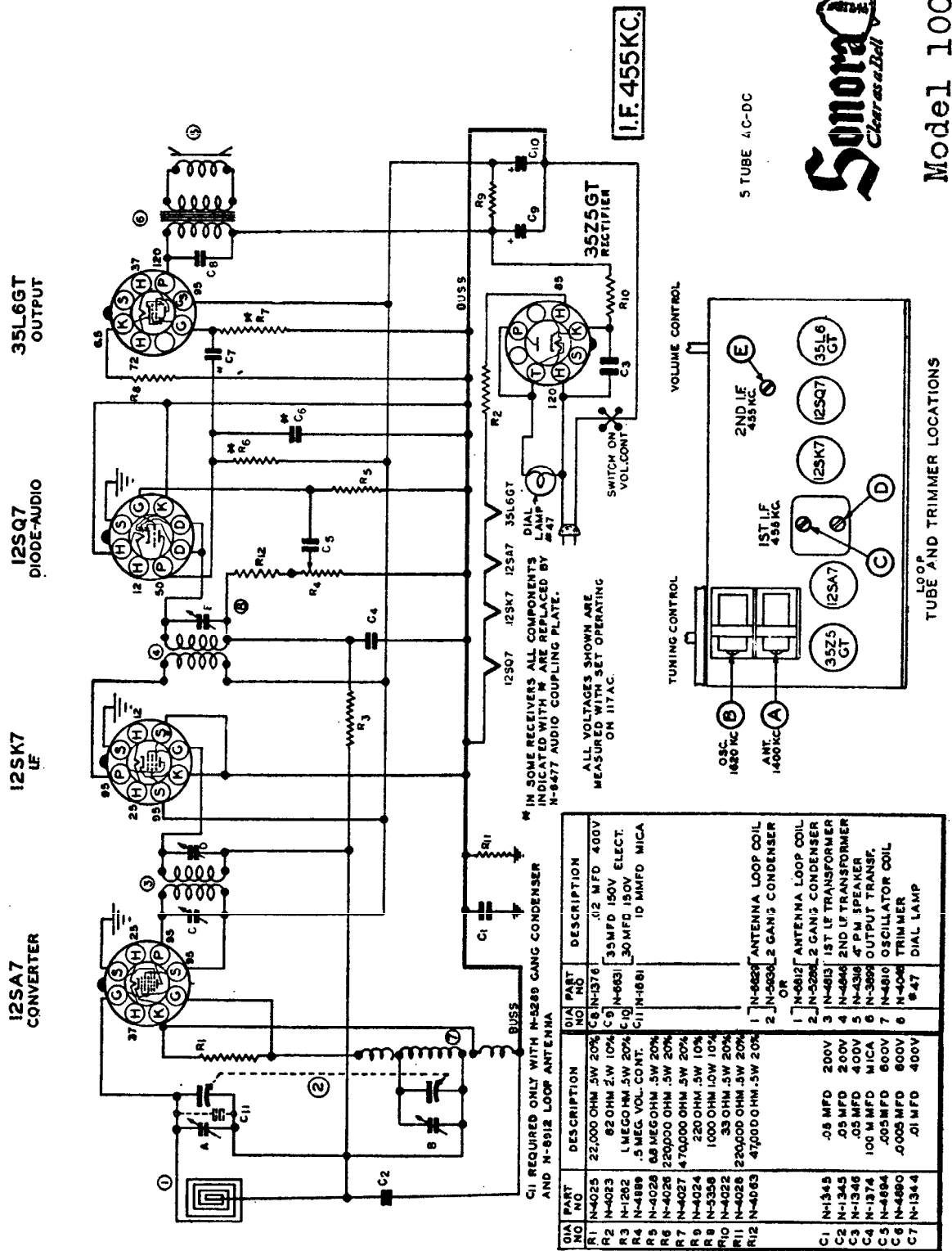

QIA PART NO.	DESCRIPTION	QIA PART NO.	DESCRIPTION
R1 N-4025	22,000 OHM .5W 20%	C1 N-1376	.02 MFD 400V
R2 N-1202	620 OHM .5W 10%	C2 N-4631	.35 MFD 150V ELECT.
R3 N-4889	.5 MEG. VOL. CONT.	C3 N-1081	.30 MFD 150V ELECT.
R4 N-4026	68 MEG OHM .5W 20%	C4 N-1081	10 MMFD MICA
R5 N-4026	220,000 OHM .5W 20%		
R6 N-4027	470,000 OHM .5W 20%		
R7 N-4024	220 OHM .5W 10%		
R8 N-5358	1000 OHM .10W 10%		
R9 N-4022	330 OHM .5W 20%		
R10 N-4026	220,000 OHM .5W 20%		
R11 N-4063	470,000 OHM .5W 20%		
R12 N-4063	470,000 OHM .5W 20%		
C1 N-1345	.05 MFD 200V	1 N-9654	ANTENNA LOOP COIL
C2 N-1345	.05 MFD 200V	2 N-5696	2 GANG CONDENSER OR
C3 N-1346	.05 MFD 400V	1 N-9812	ANTENNA LOOP COIL
C4 N-1374	100 M MFD MICA	2 N-5292	2 GANG CONDENSER
C5 N-4894	.005 MFD 600V	3 N-4813	1ST LF TRANSFORMER
C6 N-4890	.005 MFD 600V	4 N-4846	2ND LF TRANSFORMER
C7 N-1344	.01 MFD 400V	5 N-4366	4" P.M. SPEAKER
		6 N-3664	OUTPUT TRANSF.
		7 N-4810	OSCILLATOR COIL
		8 N-5046	TRIMMER
		9 47	DIAL LAMP

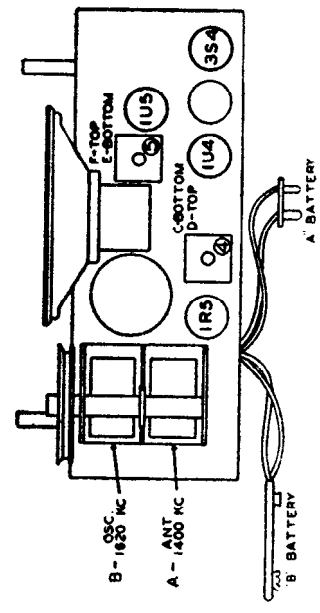
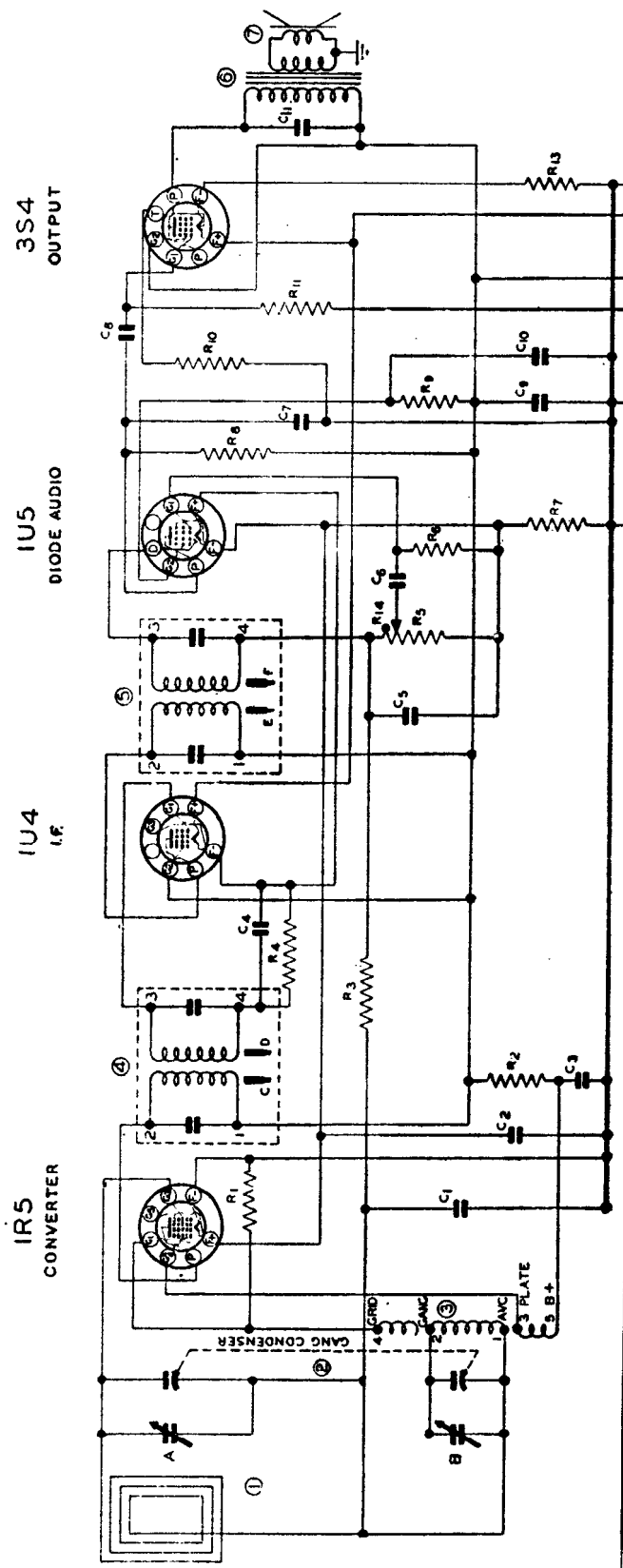
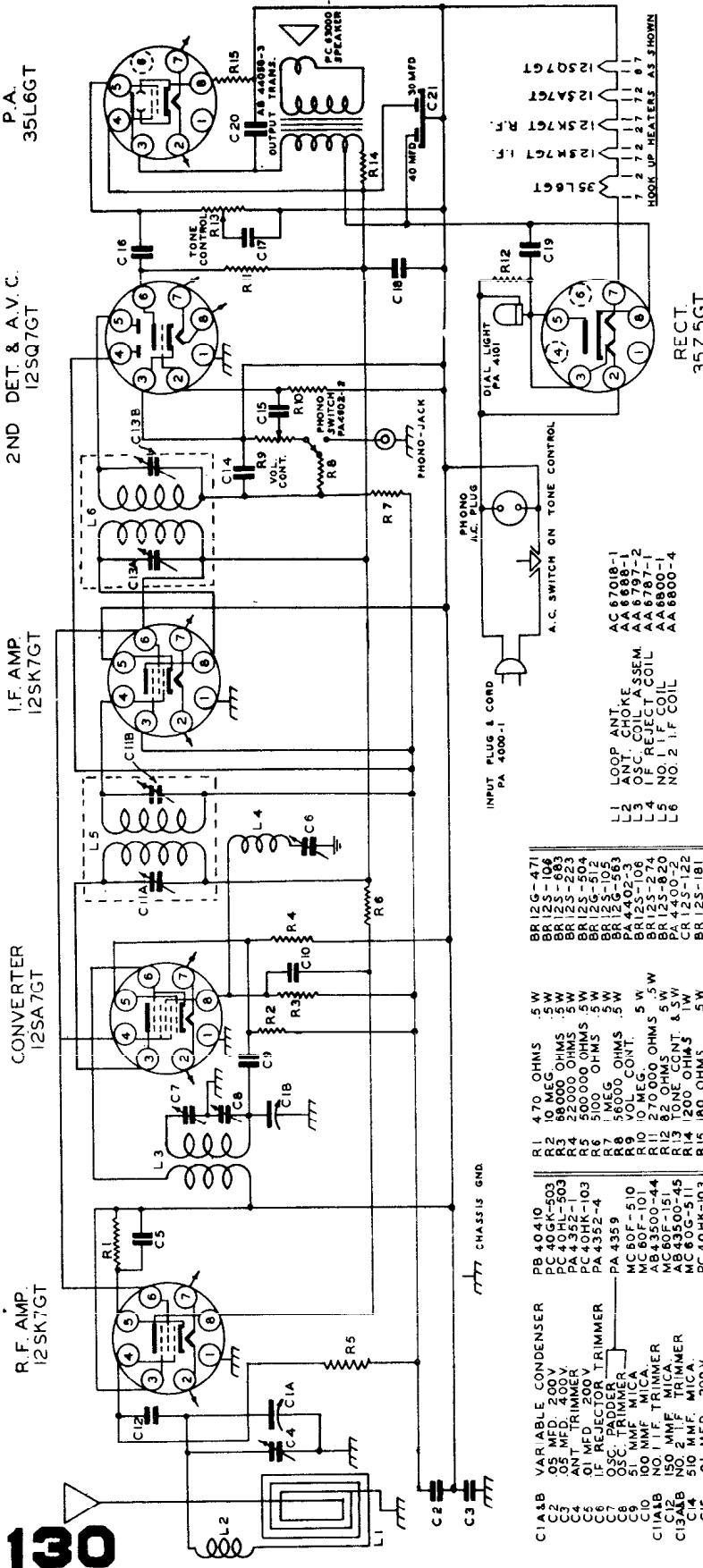

Diagram No.	Part No.	Description
C1	N-1345	.05 MFD 200 V. 20% + 20%
C2	N-1351	.1 MFD 200 V. 10% + 20%
C3	N-1345	.05 MFD 200 V. 20% + 20%
C4	N-1344	.01 MFD 400 V. 20%
C5	N-6015	100 MMFD 500 V. 20%
C6	N-4894	1005 MFD 500 V. -15% + 40%
C7	N-6015	100 MMFD 500 V. 20%
C8	N-6015	100 MMFD 500 V. 20%
C9	N-1397	.003 MFD 180 V. Electrolytic
C10	N-1394	.01 MFD 180 V. 20%
C11	N-6377	100,000 Ohm 5 W. 10%
R1	N-2973	12,000 Ohm 5 W. 10%
R2	N-5690	4.7 Megohm 5 W. 20%
R3	N-4061	6.8 Megohm 5 W. 20%
R4	N-4028	1.0 Megohm Volume Control
R5	N-6779	6.8 Megohm 5 W. 20%
R6	N-4028	1.0 Megohm Volume Control
R7	N-4279	820 Ohm 5 W. 10%
R8	N-1262	1.0 Megohm 5 W. 20%
R9	N-5473	3.9 Megohm 5 W. 10%
R10	N-6793	1,200 Ohm 5 W. 10%
R11	N-4277	2.2 Megohm 5 W. 20%
R12	N-4225	680 Ohm 5 W. 10%
R13	N-6782	27 Ohm 5 W. 10%
R14	N-6781	47,000 Ohm (In Volume Control)
1	N-5986	Antenna Loop Coil
2	N-6003	Grid Stopper Coil
3	N-6003	Oscillator Coil
4	N-6865	Coil, 1st I.F.
5	N-6866	Coil, 2nd I.F.
6	N-6791	Output Transformer
7	N-6681	4" FM Speaker

MANUAL OF 1949 MOST-OFTEN-NEEDED RADIO DIAGRAMS



- | | | | |
|-------|-------------------------|-------------|------|
| C1A&B | VARIABLE CONDENSER | PB 40410 | |
| C2 | .05 MFD. 200V. | PC 405K-503 | .5W |
| C3 | .05 MFD. 400V. | PC 40HL-503 | .5W |
| C4 | ANT. TRIMMER | PC 43K-103 | .5W |
| C5 | I.F. TRIMMER | PA 4352-4 | .5W |
| C6 | RECTIFIER TRIMMER | PA 4352-4 | .5W |
| C7 | OSC. PADDER | PA 4359 | .510 |
| C8 | 51 MMF MICA | MC 80F-101 | |
| C9 | NO. 2 I.F. COIL | MC 80F-101 | |
| C10 | NO. 1 I.F. COIL | AB 43500-44 | |
| C11A | 150 MMF TRIMMER | MC 60F-151 | |
| C11B | NO. 2 I.F. COIL | AB 43500-45 | |
| C11C | 510 MMF MICA | MC 60G-511 | |
| C12 | .01 MFD. 200V. | PC 40HK-103 | |
| C13 | .01 MFD. 200V. | PC 40HL-102 | |
| C14 | .01 MFD. 200V. | PC 40CL-104 | |
| C15 | .05 MFD. 400V. | PC 40HL-503 | |
| C16 | .03 MFD. 400V. | PC 40GL-303 | |
| C17 | 40-30 MFD. ELECT. COND. | PA 4304-1 | |
| C18 | .05 MFD. 400V. | PC 40HL-503 | |
| C19 | .03 MFD. 400V. | PC 40GL-303 | |
| C20 | .05 MFD. 400V. | PC 40HL-503 | |
| C21 | 40-30 MFD. ELECT. COND. | PA 4304-1 | |

- BR 12S-471**
 BR 12S-106
 BR 12S-223
 BR 12S-504
 BR 12S-512
 BR 12S-105
 BR 12S-105
 BR 12S-106
 BR 12S-274
 BR 12S-274
 BR 12S-106
 BR 12S-106
 BR 12S-106
 BR 12S-106

- L1** LOOP ANT.
L2 ANT. CHOKE
L3 ANT. COIL ASSEM.
L4 I.F. REJECT COIL
L5 NO. 1 I.F. COIL
L6 NO. 2 I.F. COIL

- R1** 470 OHMS .5W
R2 10 MEG OHMS .5W
R3 50,000 OHMS .5W
R4 500,000 OHMS .5W
R5 500,000 OHMS .5W
R6 500,000 OHMS .5W
R7 1 MEG .5W
R8 50,000 OHMS .5W
R9 10 MEG CONT. .5W
R10 10 MEG CONT. .5W
R11 270,000 OHMS .5W
R12 82 OHMS .5W
R13 TONE CONT. & SW
R14 1200 OHMS .5W
R15 180 OHMS .5W

- AC 67018-1**
 AA 6688-1
 AA 6797-2
 AA 6797-1
 AA 6800-1
 AA 6800-4

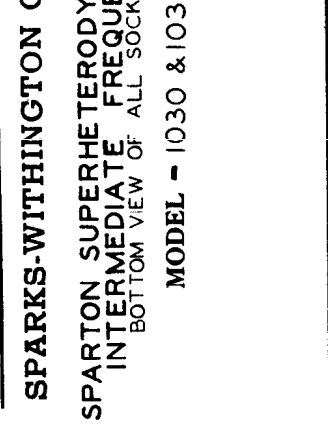

SPARKS-WITHINGTON COMPANY

SPARTON SUPERHETERODYNE MODEL 6L8
INTERMEDIATE FREQUENCY 456 KC.
 BOTTOM VIEW OF ALL SOCKET CONNECTIONS

MODEL - 1030 & 1030A

MANUAL OF 1949 MOST-OFTEN-NEEDED RADIO DIAGRAMS

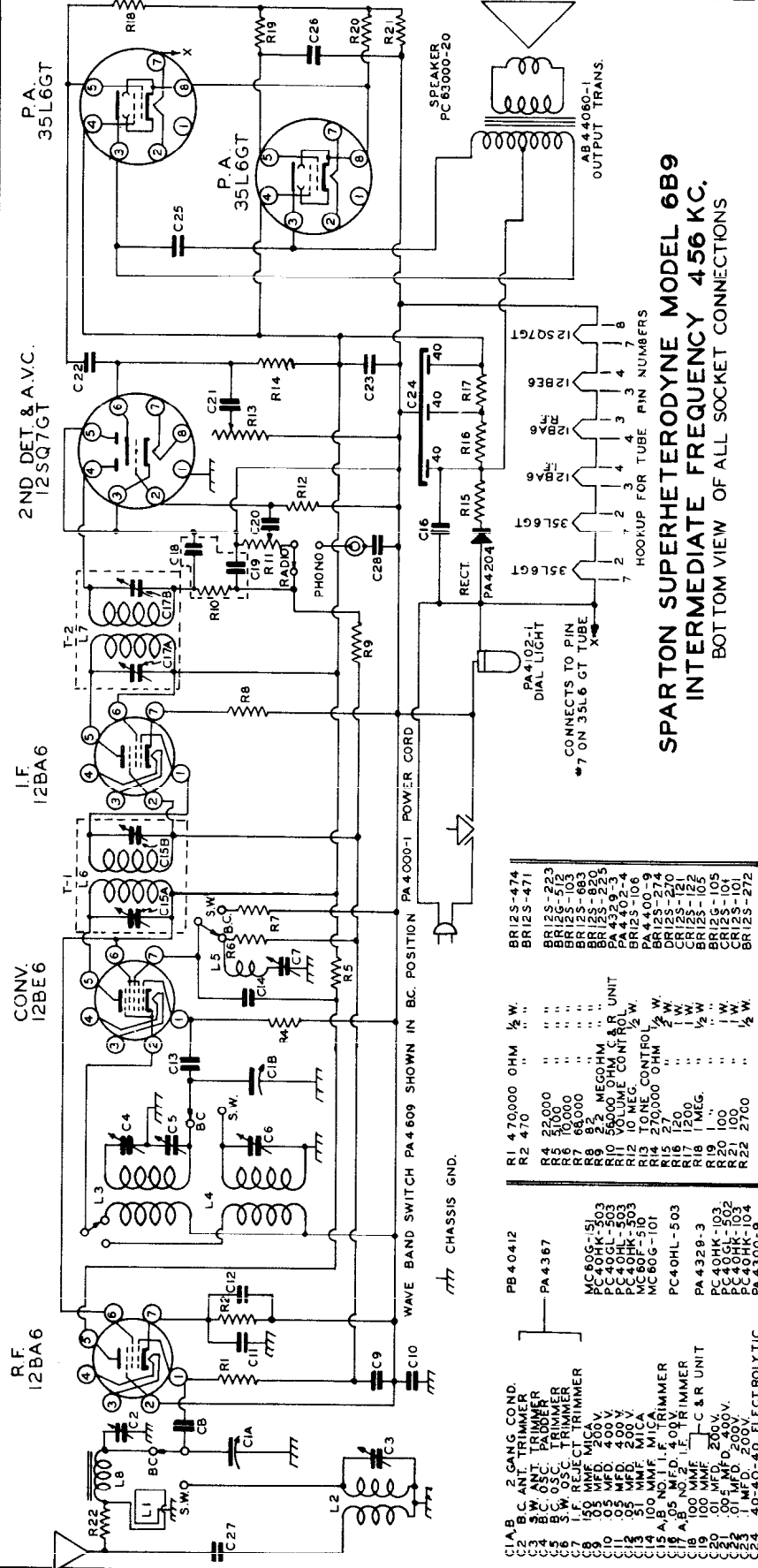

SPARTON SUPERHETERODYNE MODEL 6B9
INTERMEDIATE FREQUENCY 456 KC.
 BOTTOM VIEW OF ALL SOCKET CONNECTIONS

TUBE	FUNCTION	Voltage of Socket Prongs to B- See Prong Nos. on Schematic.							
		No. 1	No. 2	No. 3	No. 4	No. 5	No. 6	No. 7	No. 8
35L6	P.A.	0	80*	82	90	0.25	117*	117*	11
35L6	P.A.	0	80*	82	90	0.25	5.6	48*	11
12 SQ 7	1st Audio, Det. & A.V.C.	0	-0.5	0	-0.5	0	61	12*	0
12 BA 6	I.F. AMP.	0	0	48*	36*	90	0.8	-	-
12 BA 6	R.F. AMP.	0	0	24*	36*	75	90	2.3	-
12 BE 6	CONV. & OSC.	-3.8	0	24*	12*	90	90	0	-

Line Voltage: 117 Volts AC
Position of Volume Control: Full with set tuned to quiet channel.
Position of Band Switch: B.C.

* AC Volts.
 ** Cannot be measured with 20,000 ohms per volt voltmeter.

T1 NO. 1 I.F. TRANSFORMER ASSEM. AB 43502-24
 T2 NO. 2 I.F. TRANSFORMER ASSEM. AB 43502-25
 SERVICE NOTE: THESE TRANSFORMERS
 SUPPLIED IN COMPLETE ASSEMBLIES ONLY.



MANUAL OF 1949 MOST-OFTEN-NEEDED RADIO DIAGRAMS

Sparton Superheterodyne
CHASSIS - 8L9
MODEL - 121, 1058, 1059, 1060
1061, 1064, 1072

STEP BY STEP ALIGNMENT PROCEDURE

OPERATION	ALIGNMENT OF	GENERATOR CONNECTED TO	DUMMY ANT.	GENERATOR FREQUENCY	BAND SWITCH SETTING	TUNING COND. SETTING	TRIMMER	REMARKS
1.	Set dial pointer even with left-hand stop line with condenser gang closed.							
2.	Connect output meter across speaker terminals.							
3.	A.M. - I.F.	Pin #7 of 6BE6 Conv. Tube	.02 MFD. Cond.	456 KC.	A.M.	Open	T4 Sec. Slug	Max. Reading
							T4 Pri. Slug	Max. Reading
							T2 Sec. Slug	Max. Reading
							T2 Pri. Slug	Max. Reading
4.	Repeat operation #3.							
5.	A.M. - R.F.	A.M. Ant. On Cabinet	*	1500 KC.	A.M.	1500 KC.	C2B Osc. Tri.	Peak Accurately
1500 KC.				1500 KC.		C2D Ant. Tri.	Peak Accurately	
6.								
7.	Repeat operations #5 and #6.							
8.	Check Calibrations at 600, 1000 and 1500 KC.							
10.	F.M. - I.F. Alignment using an A.M. Generator and Output Meter.							
11.	T5 F.M. Ratio Det.	Pin #1 of 2nd 6BA6 Tube	.02 MFD. Cond.	10.7 MC.	F.M.	Open	T5 Sec. Slug	Max. Reading
							T5 Pri. Slug	Max. Reading
12.	NOTE: Operations 11, 13, 14, 15, 18 and 19 must be made with generator output as low as possible, consistent with a usable output meter reading.							
13.	T3 2nd F.M. - I.F.	Pin #1 1st 6AB6 Tube	.02 MFD. Cond.	10.7 MC.	F.M.	Open	T3 Sec. Slug	Max. Reading
							T3 Pri. Slug	Max. Reading
14.	T1 1st F.M. - I.F.	Pin #8 on 7F8 Conv. Tube	.02 MFD. Cond.	10.7 MC.	F.M.	Open	T1 Sec. Slug	Max. Reading
							T1 Pri. Slug	Max. Reading
15.	Adjust secondary slug on T5 ratio detector transformer to minimum deflection or dip on output meter. Under certain conditions it is possible to adjust T5 sec. slug to minimum noise with the receiver tuned to a weak station. This operation is very critical and the receiver must be tuned to the center response only.							
16.	F.M. - R.F. alignment using an A.M. generator with frequencies of 88 to 108 MC. and a vacuum tube voltmeter, or D.C. voltmeter. (20,000 OHMS per volt).							
17.	Place meter across C32 elect. condenser. (Meter reading approx. 1 volt.)							
18.	F.M. - R.F.	F.M. Ant.	Match Gen. to 300 OHMS	106 MC.	F.M.	106MC.	C39 Osc. Tri.	Max. A.V.C.V.
							C2C Ant. Tri.	Peak Accurately
19.	Check calibration at 88 MC.							

* Use standard dummy antenna

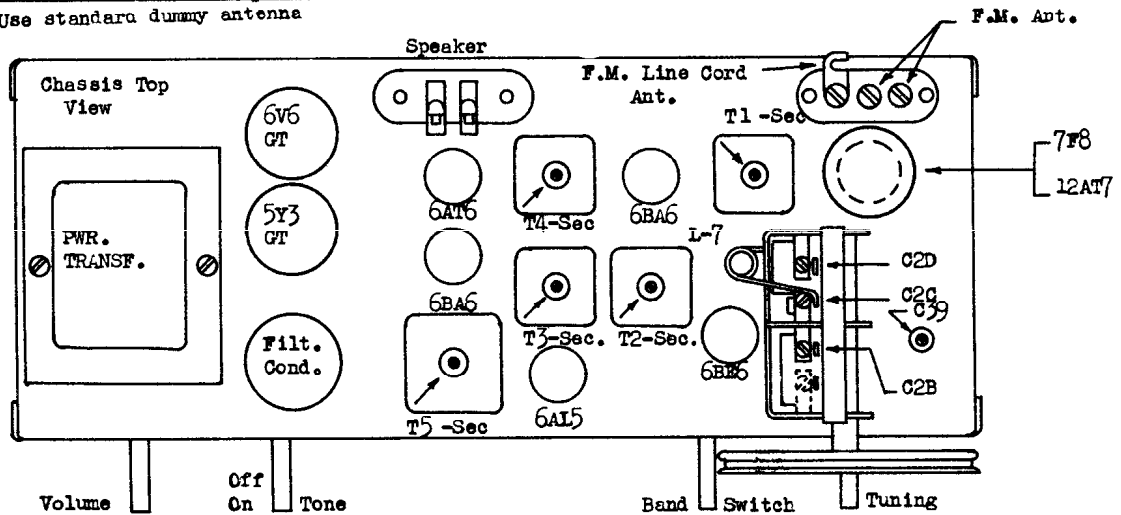

MANUAL OF 1949 MOST-OFTEN-NEEDED RADIO DIAGRAMS

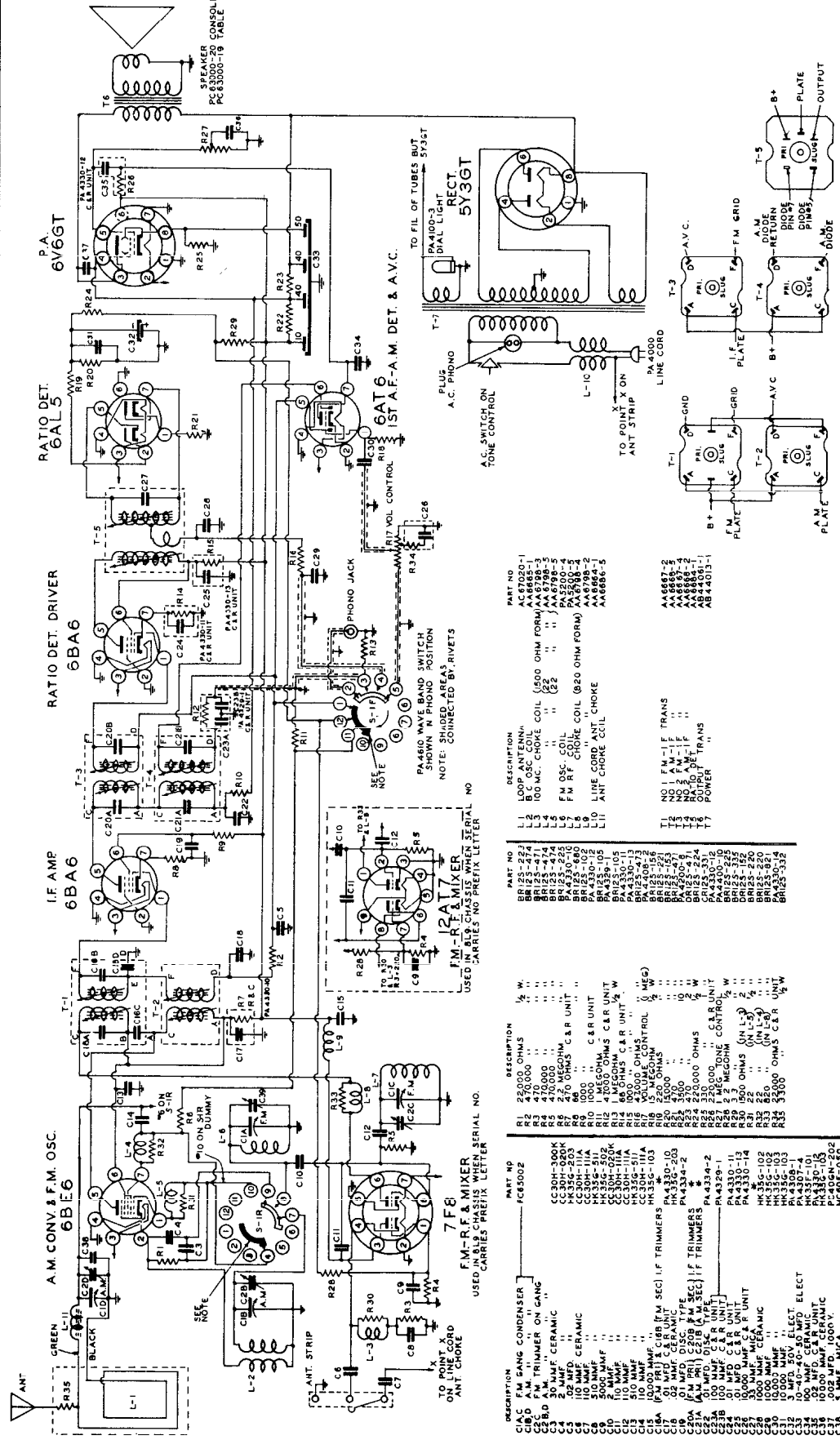

SPECIAL SERVICE NOTE: THESE TRANSFORMERS SUPPLIED IN COMPLETE ASSEMBLIES ONLY.

PART NO.	DESCRIPTION
L1	LOOP ANTENNA
L2	100 MC. CHOKE COIL
L3	100 MC. CHOKE COIL
L4	100 MC. CHOKE COIL
L5	100 MC. CHOKE COIL
L6	100 MC. CHOKE COIL
L7	100 MC. CHOKE COIL
L8	100 MC. CHOKE COIL
L9	100 MC. CHOKE COIL
L10	100 MC. CHOKE COIL
L11	100 MC. CHOKE COIL
L12	100 MC. CHOKE COIL
L13	100 MC. CHOKE COIL
L14	100 MC. CHOKE COIL
L15	100 MC. CHOKE COIL
L16	100 MC. CHOKE COIL
L17	100 MC. CHOKE COIL
L18	100 MC. CHOKE COIL
L19	100 MC. CHOKE COIL
L20	100 MC. CHOKE COIL
L21	100 MC. CHOKE COIL
L22	100 MC. CHOKE COIL
L23	100 MC. CHOKE COIL
L24	100 MC. CHOKE COIL
L25	100 MC. CHOKE COIL
L26	100 MC. CHOKE COIL
L27	100 MC. CHOKE COIL
L28	100 MC. CHOKE COIL
L29	100 MC. CHOKE COIL
L30	100 MC. CHOKE COIL
L31	100 MC. CHOKE COIL
L32	100 MC. CHOKE COIL
L33	100 MC. CHOKE COIL
L34	100 MC. CHOKE COIL
L35	100 MC. CHOKE COIL
L36	100 MC. CHOKE COIL
L37	100 MC. CHOKE COIL
L38	100 MC. CHOKE COIL
L39	100 MC. CHOKE COIL
L40	100 MC. CHOKE COIL
L41	100 MC. CHOKE COIL
L42	100 MC. CHOKE COIL
L43	100 MC. CHOKE COIL
L44	100 MC. CHOKE COIL
L45	100 MC. CHOKE COIL
L46	100 MC. CHOKE COIL
L47	100 MC. CHOKE COIL
L48	100 MC. CHOKE COIL
L49	100 MC. CHOKE COIL
L50	100 MC. CHOKE COIL
L51	100 MC. CHOKE COIL
L52	100 MC. CHOKE COIL
L53	100 MC. CHOKE COIL
L54	100 MC. CHOKE COIL
L55	100 MC. CHOKE COIL
L56	100 MC. CHOKE COIL
L57	100 MC. CHOKE COIL
L58	100 MC. CHOKE COIL
L59	100 MC. CHOKE COIL
L60	100 MC. CHOKE COIL
L61	100 MC. CHOKE COIL
L62	100 MC. CHOKE COIL
L63	100 MC. CHOKE COIL
L64	100 MC. CHOKE COIL
L65	100 MC. CHOKE COIL
L66	100 MC. CHOKE COIL
L67	100 MC. CHOKE COIL
L68	100 MC. CHOKE COIL
L69	100 MC. CHOKE COIL
L70	100 MC. CHOKE COIL
L71	100 MC. CHOKE COIL
L72	100 MC. CHOKE COIL
L73	100 MC. CHOKE COIL
L74	100 MC. CHOKE COIL
L75	100 MC. CHOKE COIL
L76	100 MC. CHOKE COIL
L77	100 MC. CHOKE COIL
L78	100 MC. CHOKE COIL
L79	100 MC. CHOKE COIL
L80	100 MC. CHOKE COIL
L81	100 MC. CHOKE COIL
L82	100 MC. CHOKE COIL
L83	100 MC. CHOKE COIL
L84	100 MC. CHOKE COIL
L85	100 MC. CHOKE COIL
L86	100 MC. CHOKE COIL
L87	100 MC. CHOKE COIL
L88	100 MC. CHOKE COIL
L89	100 MC. CHOKE COIL
L90	100 MC. CHOKE COIL
L91	100 MC. CHOKE COIL
L92	100 MC. CHOKE COIL
L93	100 MC. CHOKE COIL
L94	100 MC. CHOKE COIL
L95	100 MC. CHOKE COIL
L96	100 MC. CHOKE COIL
L97	100 MC. CHOKE COIL
L98	100 MC. CHOKE COIL
L99	100 MC. CHOKE COIL
L100	100 MC. CHOKE COIL

TO POINT X ON ANT. CHOKE
TO POINT X ON ANT. STRIP
TO POINT X ON ANT. CHOKE

TO POINT X ON ANT. CHOKE

CHASSIS - 8L9
MODEL - 121,1058,1059,1060,1061,1064,1072

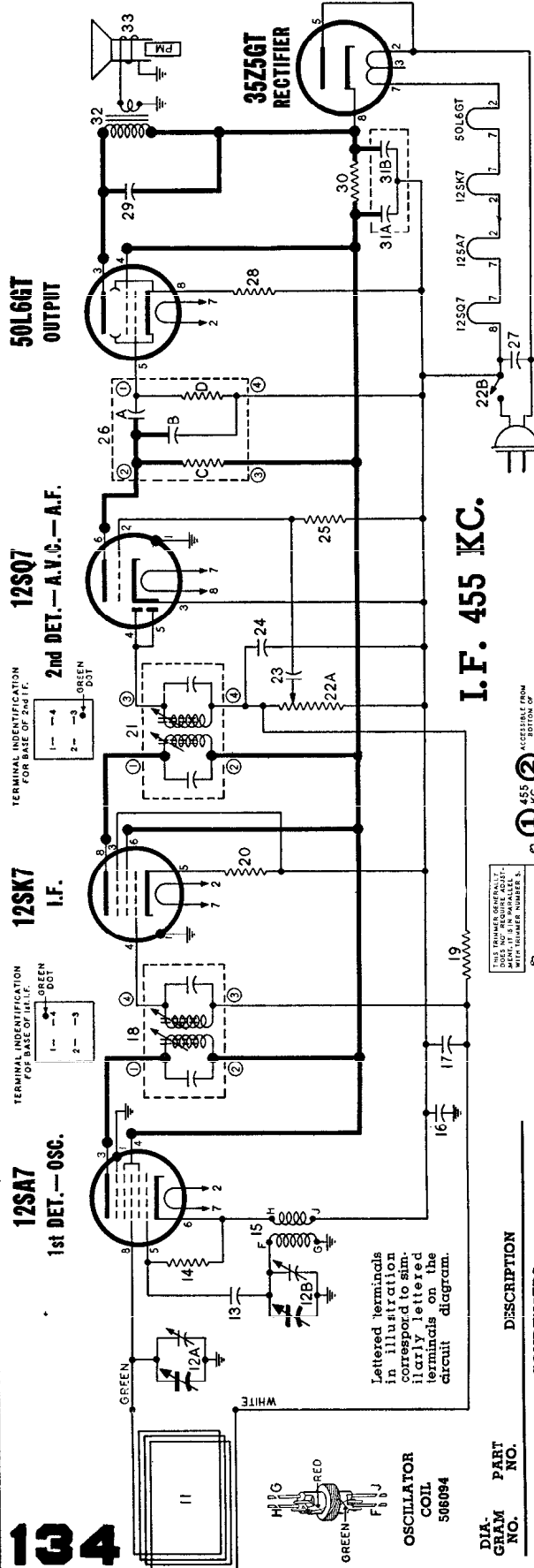

SOCKET VOLTAGES

Measured with voltmeter having sensitivity of 1000 ohms per volt except where indicated by (*). The (*) symbol designates a vacuum tube volt-meter measurement.

VOLUME ON FULL WITH NO SIGNAL

DIAL TUNED TO 540 KC.

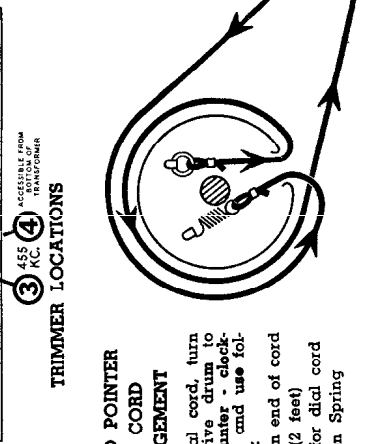
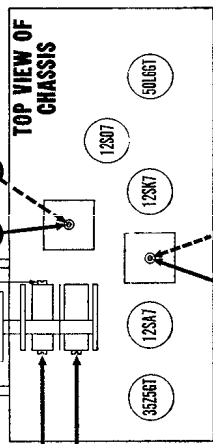
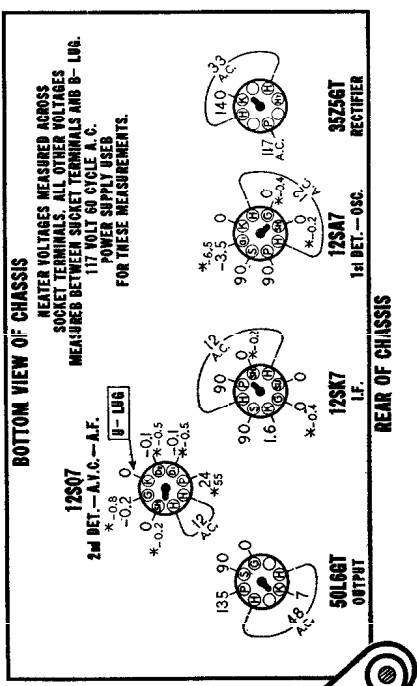

- TRIMMER LOCATIONS**
- DIAL AND POINTER DRIVE CORD ARRANGEMENT**
- To string dial cord, turn the main drive drum to maximum counter-clockwise position and use following parts:
114955 Clip on end of cord
117057 Cord (2 feet)
119087 Ring for dial cord
505161 Tension Spring
- CONDENSERS**
- 12-A, B...506081 Condenser—variable gang (with drum)...
 - 13...502931 Condenser—mica 100 Mmfd. 500 volt.
 - 16...502158 Condenser—.15 Mid. 400 volt.
 - 17...502153 Condenser—.05 Mid. 200 volt.
 - 23...504726 Condenser—.01 Mid. 200 volt.
 - 24...502931 Condenser—mica 100 Mmfd. 500 volt.
 - 26-A...505858 Condenser—ceramic .005 Mid. 450 volt (part of audio coupling unit)...
 - 28-B...505858 Condenser—ceramic 250 Mmfd. 450 volt (part of audio coupling unit)...
 - 29...502154 Condenser—.05 Mid. 600 volt.
 - 27...504726 Condenser—.01 Mid. 200 volt.
 - 31-A, B...506090 Condenser—electrolytic
A—20 Mid. 150 volt }
B—30 Mid. 150 volt }
- RESISTORS**
- 14...510061 Resistor—carbon 22,000 Ohms 1/4 watt.
 - 19...510094 Resistor—carbon 3.3 Meg. 1/4 watt.
 - 20...510022 Resistor—carbon 150 Ohms 1/4 watt.
 - 22-A, B...506087 Volume control 1 Meg. (with switch).
 - 25...510097 Resistor—carbon 10 Meg. 1/4 watt.
 - 26-C, D...505858 Resistor—carbon 470,000 Ohms 1/5 watt (part of audio coupling unit)...
 - 28...510128 Resistor—carbon 330 Ohms 1/2 watt.
 - 30...510243 Resistor—carbon 2,200 Ohms 1 watt.
- OTHER ELECTRICAL PARTS**
- 11...506088 Loop antenna and cabinet back.
 - 13...506084 Coil—oscillator.
 - 15...506083 Transformer—1st I.F.
 - 21...506084 Transformer—2nd I.F.
 - 26...505858 Audio coupling unit
A—Condenser—ceramic .005 Mid. 450 volt
B—Condenser—ceramic 250 Mmfd. 450 volt
C—Resistor—carbon 470,000 Ohms 1/5 watt
D—Resistor—carbon 470,000 Ohms 1/5 watt
 - 32...506089 Transformer—output
 - 33...506079 Speaker—F.M. dynamic (4 inch)

STEWART-WARNER MODELS [C51T1 9045-A] & [C51T2 9045-B]

MANUAL OF 1949 MOST-OFTEN-NEEDED RADIO DIAGRAMS

STEWART-WARNER MODELS [A61P1 9036-A] [A61P2 9036-B] [A61P3 9036-C]

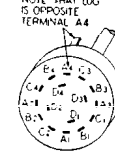
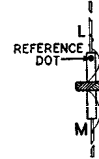
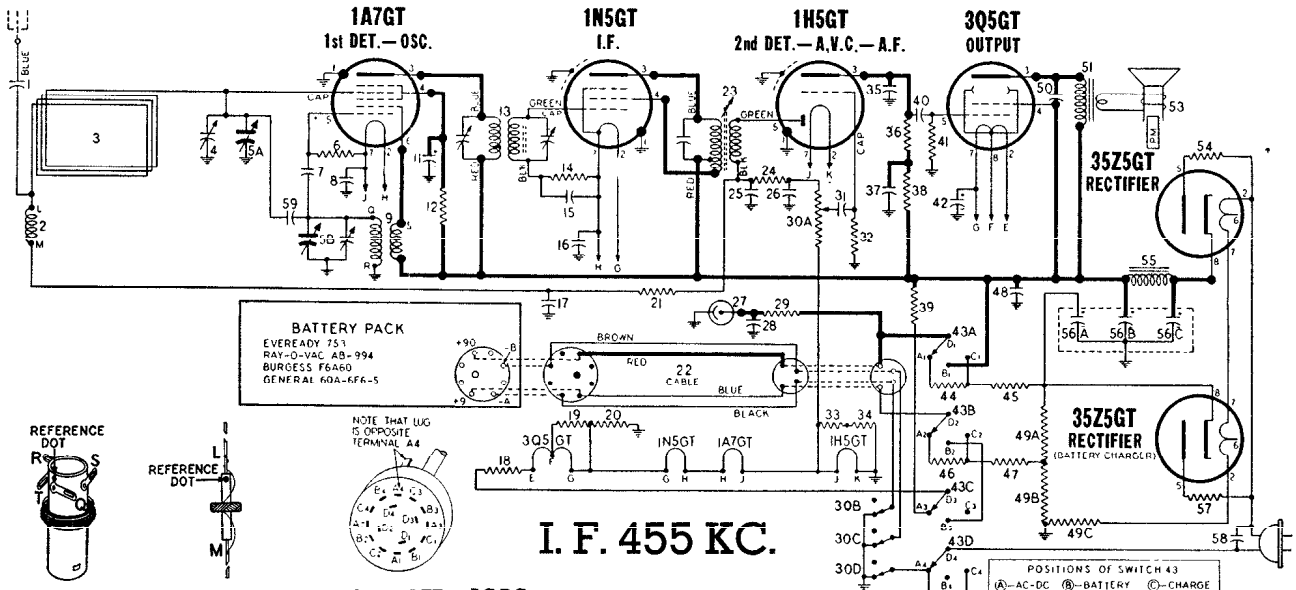

- ANTENNA COIL 505781
- OSCILLATOR COIL 502498
- CHARGE-BATT.-AC-DC SWITCH 502526

Lettered terminals in illustrations correspond to similarly lettered terminals on the circuit diagram.

I. F. 455 KC.

DIA-GRAM NO.	PART NO.	DESCRIPTION
--------------	----------	-------------

TOP VIEW OF CHASSIS

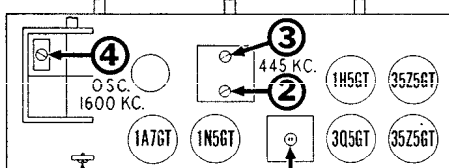

- ANT. 1600 KC. (5)
- OSC. 1600 KC. (4)
- 445 KC. TRIMMER (2)
- 1H5GT (1)
- 3Q5GT (3)
- 1A7GT (6)
- 1N5GT (7)
- 35Z5GT (8)

INDICATOR LAMP

The flashing neon lamp on the dial face indicates condition of batteries. This lamp is included in an oscillating (R-C) circuit which is designed to oscillate at approximately 3 pulses per second when batteries are in a fully charged condition. As the battery voltage decreases with use, number of pulses per second decreases.

Measured with voltmeter having sensitivity of 1000 ohms per volt except where indicated by (*). The (*) symbol designates a vacuum tube voltmeter measurement.

VOLUME ON FULL WITH NO SIGNAL DIAL TUNED TO 540 KC.

"CHARGE-BATT.-AC-DC" SWITCH IN "AC-DC" POSITION

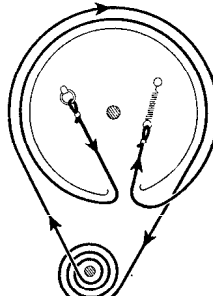
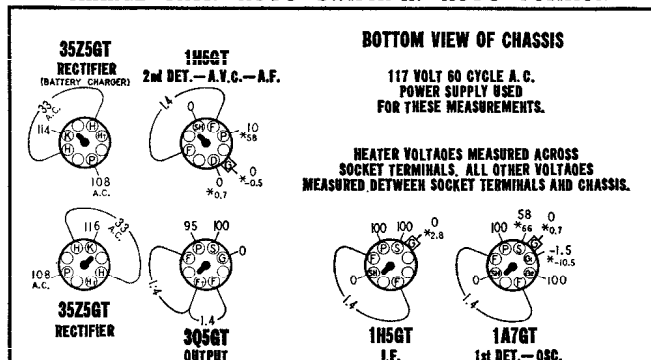

DIAL DRIVE CORD ARRANGEMENT

- To string dial cord, set gang condenser to fully open position and use following parts:
- 114955 Clip on end of cord
 - 117057 Cord (3 feet)
 - 119087 Ring for dial cord
 - 161384 Tension Spring

DIA-GRAM NO.	PART NO.	DESCRIPTION
CONDENSERS		
1	502160	Condenser—110 Mmfd. 500 volt.
4-A, B	502494	Condenser—variable gang (with drum)
5	119132	Condenser—trimmer 2 to 15 Mmfd.
7	502159	Condenser—mica 50 Mmfd. 500 volt.
8	502153	Condenser—.05 Mfd. 200 volt.
11	502547	Condenser—electrolytic 4 Mfd. 150 volt.
15	502153	Condenser—.05 Mfd. 200 volt.
16	502155	Condenser—.1 Mfd. 200 volt.
17	502153	Condenser—.05 Mfd. 200 volt.
25, 26	502159	Condenser—mica 50 Mmfd. 500 volt.
28	502155	Condenser—.1 Mfd. 200 volt.
31	502156	Condenser—.004 Mfd. 400 volt.
35	502160	Condenser—mica 110 Mmfd. 500 volt.
37	502155	Condenser—.1 Mfd. 200 volt.
40	502151	Condenser—.01 Mfd. 400 volt.
42	502527	Condenser—electrolytic 50 Mfd. 25 volt.
48	502155	Condenser—.1 Mfd. 200 volt.
50	502453	Condenser—.002 Mfd. 400 volt.
56-A, B, C	500714	Condenser—electrolytic A—20 Mfd. 150 volt B—20 Mfd. 200 volt C—20 Mfd. 200 volt
58	502159	Condenser—.05 Mfd. 200 volt.
59	502411	Condenser—2 Mmfd. 500 volt.
RESISTORS		
6	502133	Resistor—carbon 220,000 ohms 1/4 watt
12	504710	Resistor—carbon 33,000 ohms 1/4 watt.
14	502136	Resistor—carbon 10 Meg. 1/4 watt.
18	502455	Resistor—carbon 27 ohms 1/4 watt.
19	502457	Resistor—carbon 330 ohms 1/4 watt.
20	502458	Resistor—carbon 430 ohms 1/4 watt.
21	502269	Resistor—carbon 3.3 Meg. 1/4 watt.
24	502132	Resistor—carbon 100,000 ohms 1/4 watt
29	502269	Resistor—carbon 3.3 Meg. 1/4 watt.
30-A, B, C, D	502525	Volume control 1 Meg. (with switch)
32	502269	Resistor—carbon 3.3 Meg. 1/4 watt.
33, 34	502456	Resistor—carbon 220 ohms 1/4 watt.
36	502268	Resistor—carbon 1 Meg. 1/4 watt.
38	502134	Resistor—carbon 470,000 ohms 1/4 watt
39	500712	Resistor—wire wound 1830 ohms 5 watt
41	502135	Resistor—carbon 2.2 Meg. 1/4 watt.
44	502266	Resistor—carbon 15,000 ohms 1/4 watt.
45	502459	Resistor—carbon 6800 ohms 1/4 watt.
46	502457	Resistor—carbon 330 ohms 1/4 watt.
47	502455	Resistor—carbon 27 ohms 1/4 watt.
49-A, B, C	500715	Resistor—wire wound A—1460 ohms 10 watt B—155 ohms 1 watt C—310 ohms 10 watt
54	502454	Resistor—wire wound 47 ohms 1 watt.
57	502454	Resistor—wire wound 47 ohms 1 watt.
COILS AND TRANSFORMERS		
2	505781	Coil—antenna (series)
3	505440	Loop antenna
9	502498	Coil—oscillator
13	502495	Transformer—1st I.F.
23	500749	Transformer—2nd I.F.
51	502902	Trans.—output for A-502491 speaker
	502492	Trans.—output for R-502491 speaker
55	502528	Filter choke

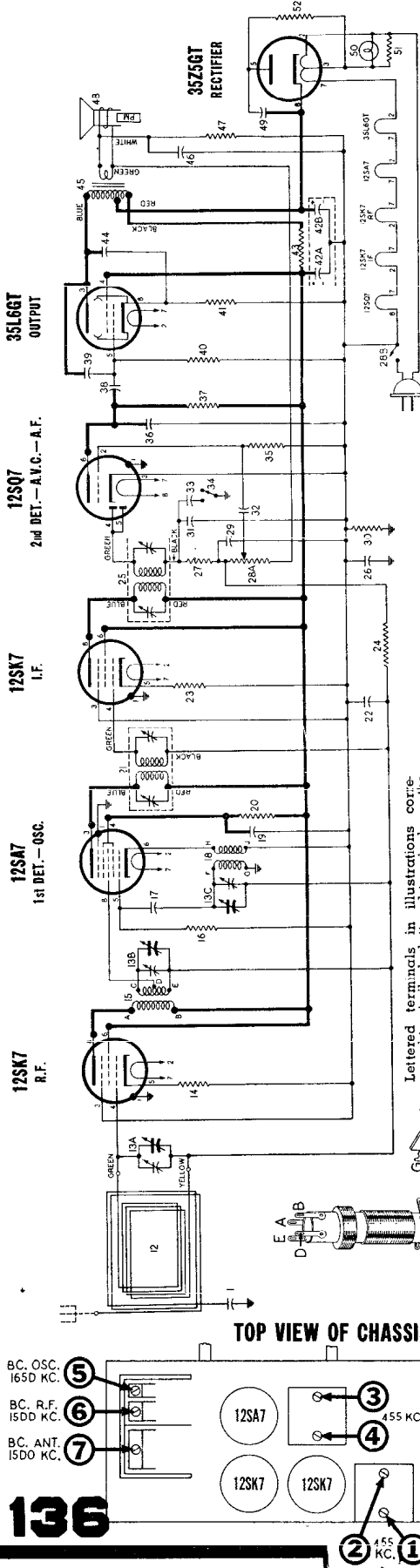

STEWART-WARNER MODELS [B61T1] [9046-A] [B61T2] [9046-B]

ALIGNMENT PROCEDURE

1. Remove chassis from cabinet—allow loop antenna to remain attached to chassis.
2. Note that there are four calibrating lines stamped into front edge of the metal dial frame. When gang condenser is fully meshed, dial pointer should be in the position indicated by first line at the left. If it is set incorrectly, release pointer clip on dial cord and reposition pointer.
3. Connect an output meter across the speaker voice coil or from plate of 35L6GT tube to E—through a .1 Mfd. condenser (see voltage chart for convenient B— connection).
4. Connect ground lead of signal generator to B—lug. CAUTION: If your test oscillator is designed with an A.C. DC power supply, connect ground lead of signal generator to B—lug through a .25 Mfd. condenser.
5. Set volume control to maximum volume position and use a weak signal from the signal generator.

Lettered terminals in illustrations correspond to similarly lettered terminals on the circuit diagram.

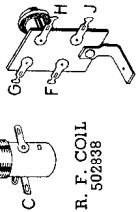

DIA. GRAM NO.	PART NO.	DESCRIPTION
11	502152	Condenser—.02 Mfd. 400 volt.
13	A, B, C 502153	Condenser—variable gang (with drum).
16	502154	Condenser—mica 50 Mmfd. 500 volt.
19	502155	Condenser—.25 Mfd. 200 volt.
25	502155	Condenser—.1 Mfd. 200 volt.
26	502158	Condenser—.15 Mfd. 400 volt.
29	505026	Condenser—ceramic 150 Mmfd. 350 volt.
31	505026	Condenser—ceramic .002 Mfd. 350 volt.
32	504877	Condenser—ceramic .002 Mfd. 150 volt.
36	502160	Condenser—mica 110 Mmfd. 500 volt.
39	505028	Condenser—.05 Mfd. 50 volt.
38	504973	Condenser—ceramic 22 Mmfd. 500 volt.
42	A, B 500256	Condenser—electrolytic A—20 Mfd. 150 volt. B—40 Mfd. 150 volt.
44	502151	Condenser—.2 Mfd. 400 volt.
46	505071	Condenser—.2 Mfd. 400 volt.
49	502157	Condenser—.05 Mfd. 400 volt.
RESISTORS		
14	510025	Resistor—carbon 200 Ohms 1/4 watt.
16	510061	Resistor—carbon 22,000 Ohms 1/4 watt.
20	510049	Resistor—carbon 4700 Ohms 1/4 watt.
23	510021	Resistor—carbon 150 Ohms 1/4 watt.
24	510091	Resistor—carbon 1 Meg. 1/4 watt.
26	510064	Resistor—carbon 33,000 Ohms 1/4 watt.
27	504957	Volume control 1 Meg. (with switch).
28	A, B 510079	Resistor—carbon 220,000 Ohms 1/4 watt.
35	510097	Resistor—carbon 10 Meg. 1/4 watt.
37	510085	Resistor—carbon 470,000 Ohms 1/4 watt.
40	510085	Resistor—carbon 470,000 Ohms 1/4 watt.
41	510121	Resistor—carbon 150 Ohms 1/2 watt + 10%.
43	510239	Resistor—carbon 1,500 Ohms 1 watt + 10%.
47	510073	Resistor—carbon 100,000 Ohms 1/4 watt.
51	510029	Resistor—carbon 390 Ohms 1/4 watt + 10%.
52	510210	Resistor—carbon 33 Ohms 1 watt.

DUMMY ANT. IN SERIES WITH SIGNAL GENERATOR	CONNECTION OF SIG. GENERATOR OUTPUT TO RECEIVER	SIGNAL GENERATOR FREQUENCY	RECEIVER DIAL SETTING	TRIMMER NUMBER	TRIMMER DESCRIPTION	TYPE OF ADJUSTMENT
200 MMFD. Mica Condenser	Control Grid of 12SA7	455 KC	Any point where it does not affect the signal.	1-2	2nd I.F.	Adjust for maximum output. Then repeat adjustment.
200 MMFD. Mica Condenser	External Antenna Terminal on Loop Frame	1650 KC	Gang condenser fully open.	3-4	1st I.F.	Adjust for maximum output.
200 MMFD. Mica Condenser	External Antenna Terminal on Loop Frame	1500 KC	Tune to 1500 KC generator signal	5	Broadcast Oscillator (Shunt)	Adjust for maximum output.
200 MMFD. Mica Condenser	External Antenna Terminal on Loop Frame	1500 KC	Tune to 1500 KC generator signal	6	Broadcast R.F.	Adjust for maximum output.
200 MMFD. Mica Condenser	External Antenna Terminal on Loop Frame	1500 KC	Tune to 1500 KC generator signal	7	Broadcast Antenna	Adjust for maximum output.

MANUAL OF 1949 MOST-OFTEN-NEEDED RADIO DIAGRAMS

STROMBERG - CARLSON

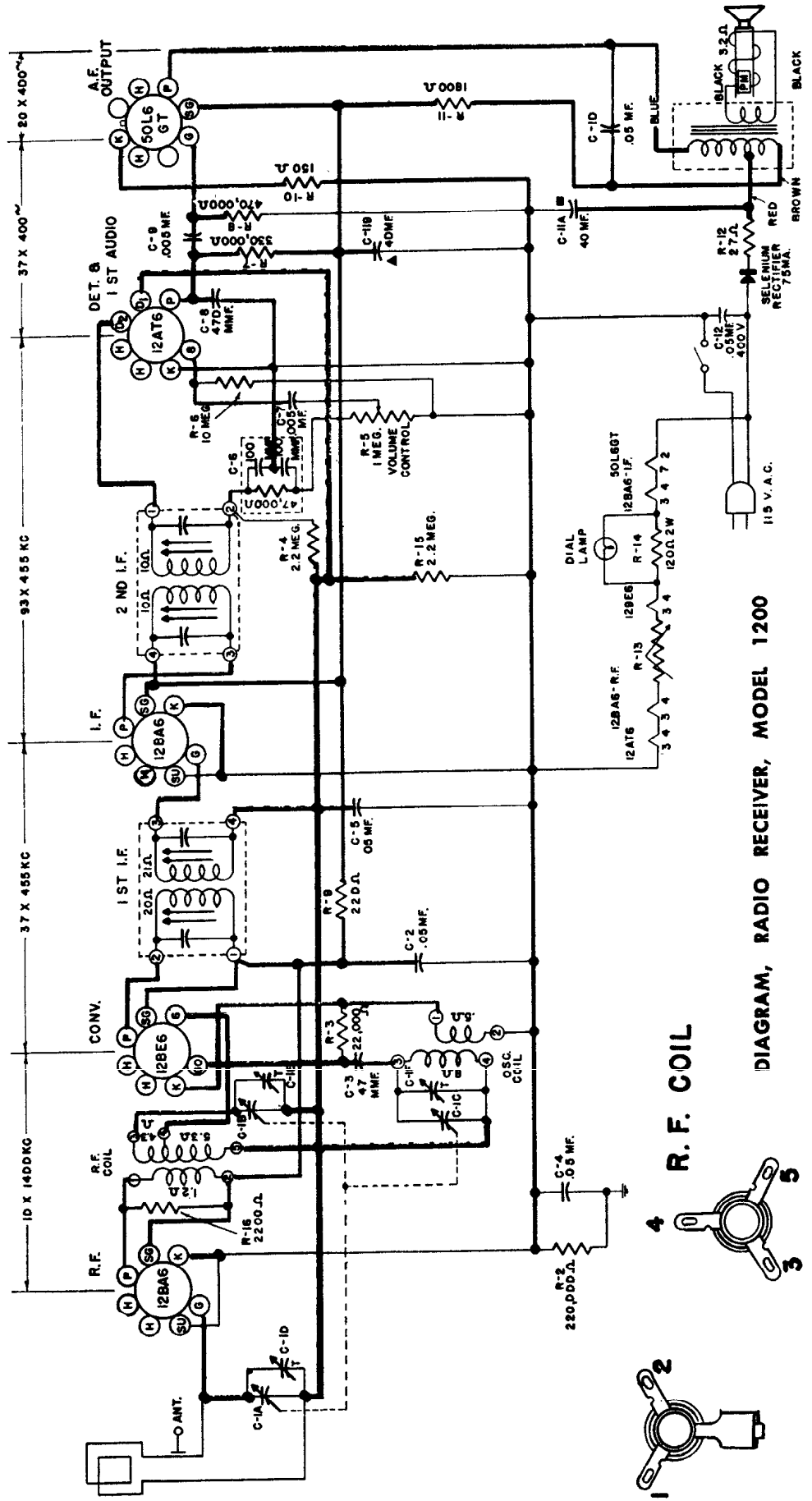

DIAGRAM, RADIO RECEIVER, MODEL 1200

75MA. BROWN BLACK

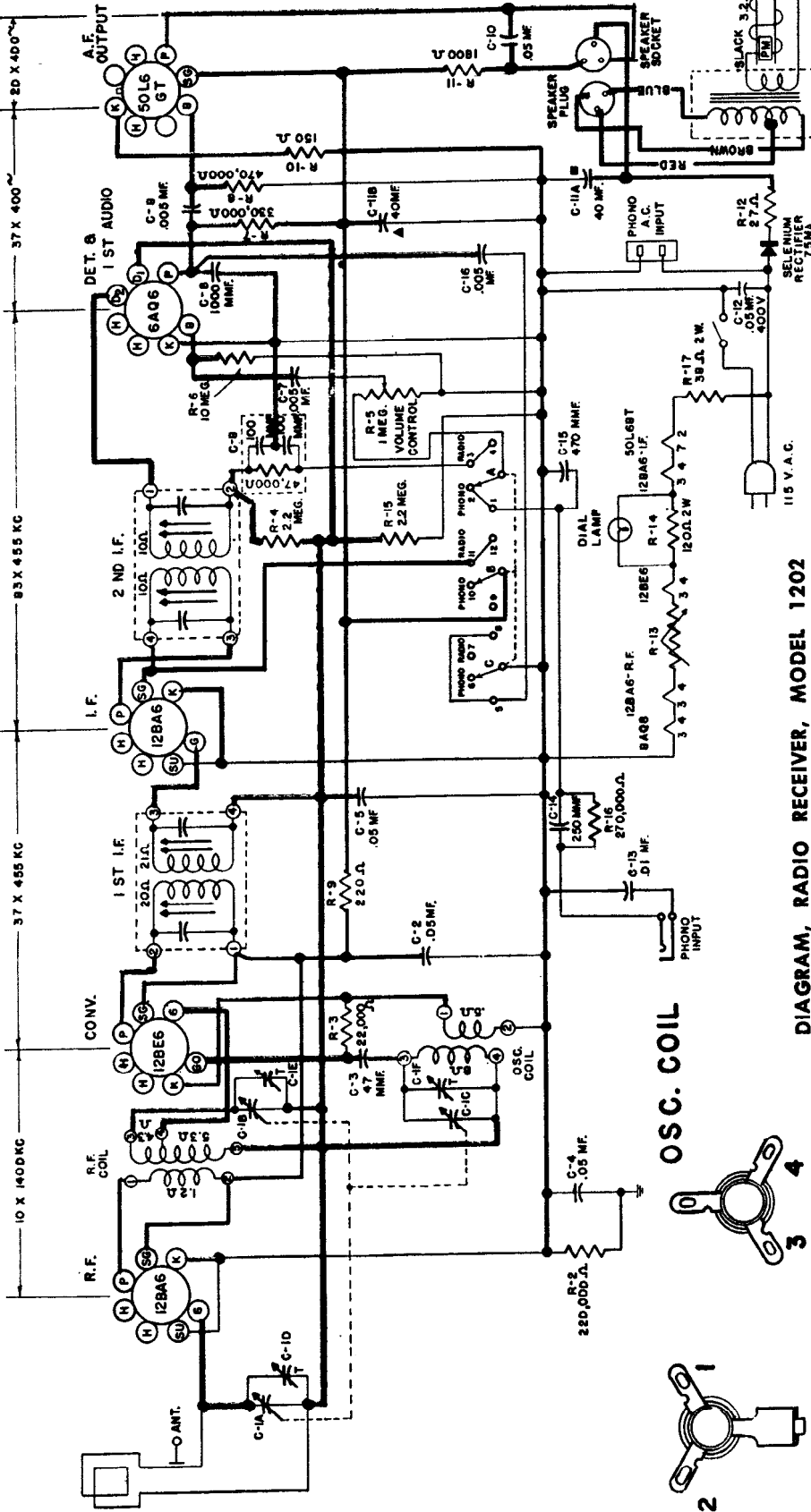

DIAGRAM, RADIO RECEIVER, MODEL 1202

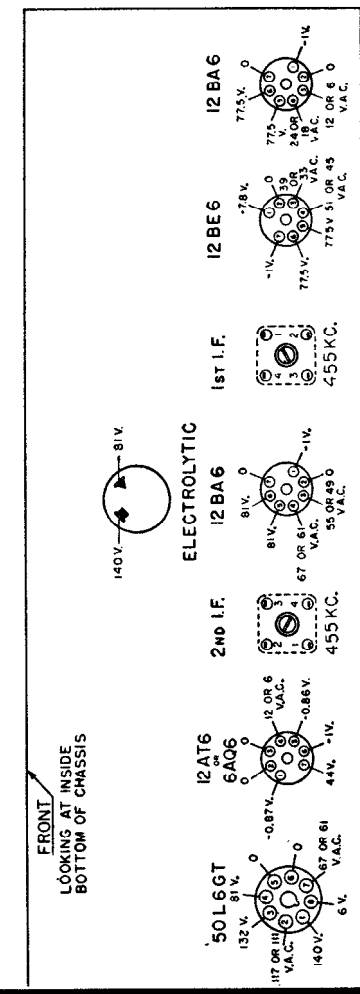
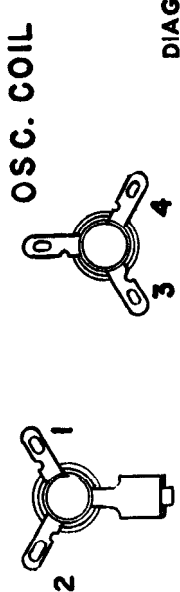

*Where two tube types or voltage values are shown, the first is for the 1200 chassis, the second is for the 1202 chassis

MANUAL OF 1949 MOST-OFTEN-NEEDED RADIO DIAGRAMS STROMBERG-CARLSON SERVICE NOTES

AC-DC RADIO RECEIVER NO. 1204

SERIES NO. 10-11

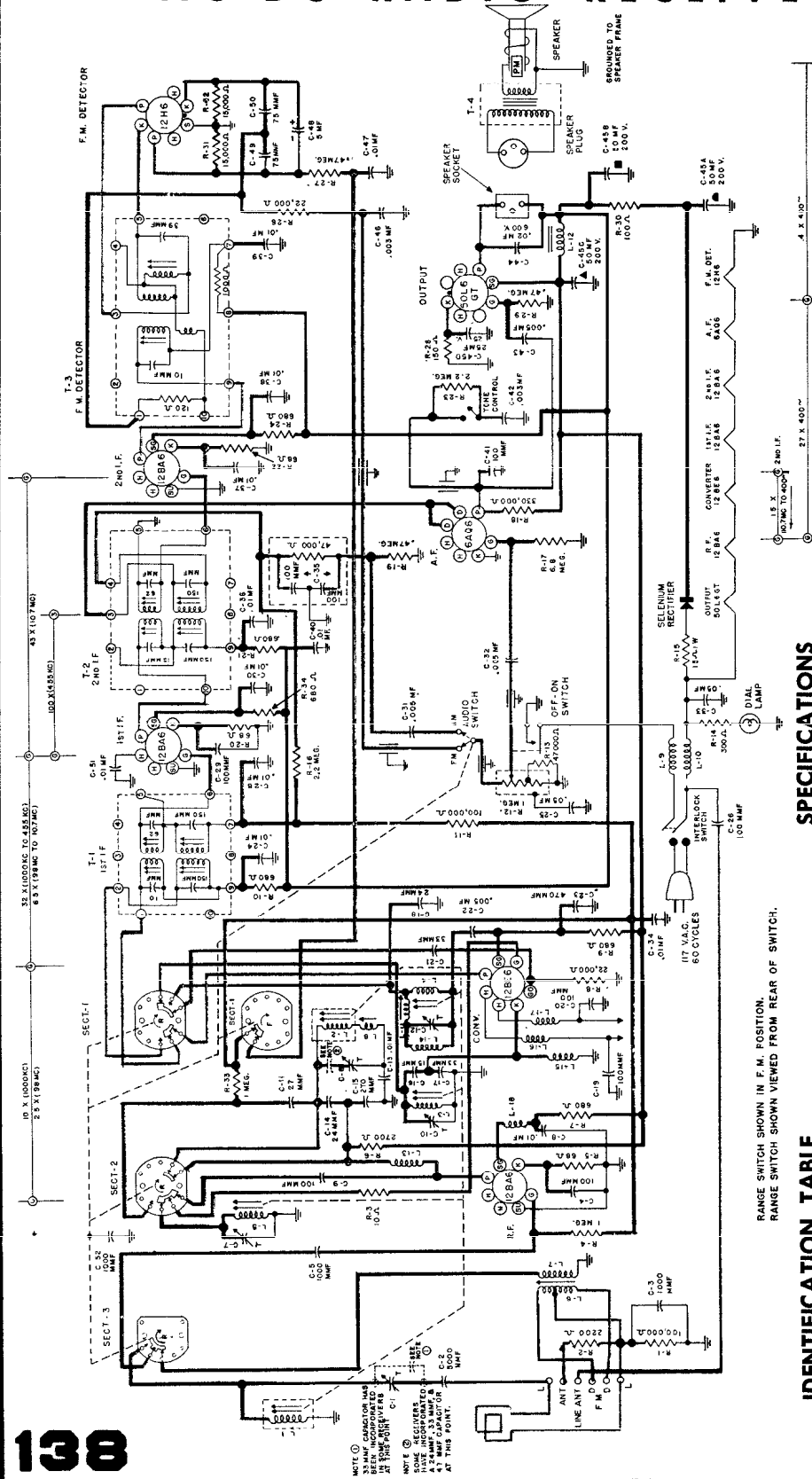

SPECIFICATIONS

- Voltage Rating..... 105-125 Volts AC-DC
- Type of Circuit..... Superheterodyne
- Tuning Range..... A.M.—540 KC.—1 600 KC.
F.M.—88 MC.—108 MC.
- Number & Type of Tubes—7
 - 3—12BA6..... R.F. Amp. and Iwo I.F. Amp.
 - 1—12BE6..... Converter
 - 1—6AQ6..... 1st Audio Amp.—A.M. Det. & AVC
 - 1—12H6..... F.M. Def.
 - 1—50.6GT..... Power Output
- Input Power Rating..... 40 Watts
- Intermediate Frequency..... A.M. 455 KC. F.M. 10.7 MC.
- Speaker Voice Coil Impedance (PM)..... 3 Ohms
- Power Output..... 1.25 Watts at less than 10% distortion

IDENTIFICATION TABLE

MODEL	CHASSIS	CABINET	SPEAKER
HI	112021	108056	1.55030
HB	112021	108044	1.55030
HME	112021	108063	1.55030
HMG	112021	108062	1.55030

MANUAL OF 1949 MOST-OFTEN-NEEDED RADIO DIAGRAMS

STROMBERG-CARLSON

ALIGNMENT PROCEDURE 1204

Band and Pointer Setting	Generator Setting	Input and Dummy	VTVM Connection and Scale	Trimmer Adj. and Notes
A.M. I.F. ALIGNMENT				
(1) AM-Pointer near middle of dial	455 kc. 400 cy. mod.	Junction C-13, 6 and L-8 200 mmf. dummy	Junction C-31, 35 3VDC scale	Adj. Pri. and Sec. cores two AM IF transformers top of chassis. Highest voltage
F.M. I.F. ALIGNMENT				
(1) FM-Pointer near middle of dial	10.7 mc 400 cy mod.	Junction C-10, 16 and L-3	AVC buss (Green and White Wire) —3VDC scale	Detune Sec. Ratio Det. Transformer adjust four FM IF cores, bottom of chassis, in following order counting from band switch—One, Four, Two Three for highest voltage. DO NOT REPEAT
(2) " "	" "	" "	" "	Adjust Pri. Ratio Det. Transformer for highest voltage.
(3) " "	" "	" "	Center terminal audio switch —3 VDC scale	Adjust Sec. Ratio Det. Transformer for ZERO voltage.
(4) Repeat (2) and (3)				
A.M. R.F. ALIGNMENT				
(1) AM-600 kc	600 kc 400 cy. mod.	Loop and link connected 200 mmf dummy to Ant. terminal	Junction C-31, 35 —3 VDC scale	Adjust C-12, 6 and 1 for highest voltage.
(2) AM-1600 kc Repeat (1) and (2)	1600 kc	" "	" "	Align L-8, 11 for highest voltage.
F.M. R.F. ALIGNMENT				
FM Pointer at 98 to 100 mc.	98 to 100 mc. 400 cy mod.	" "	AVC buss (Green and White Wire) —3 VDC scale	Adjust C-7, 10 and core L-6 and 7 for highest voltage.

Voltage and Tube Location Chart

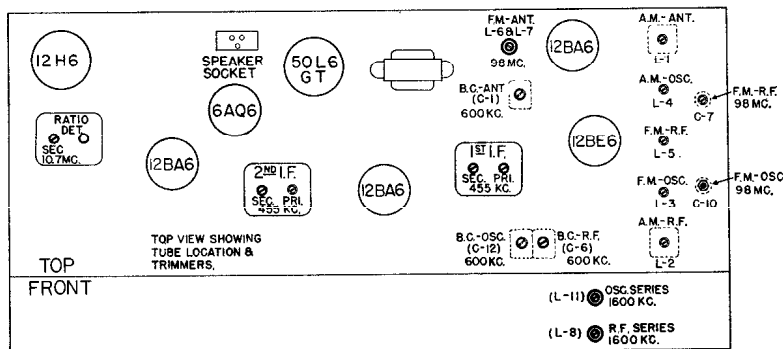

Dial Stringing Chart

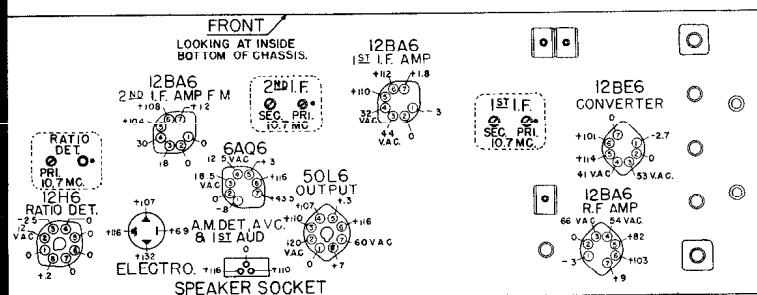
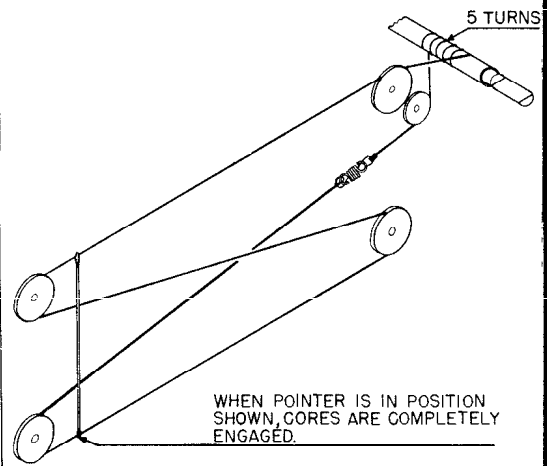

Measurements are made at 117V line, using electronic Voltmeter. Except where otherwise indicated, voltages are D.C. and are positive with respect to the reference point which is the chassis.

MANUAL OF 1949 MOST-OFTEN-NEEDED RADIO DIAGRAMS

140

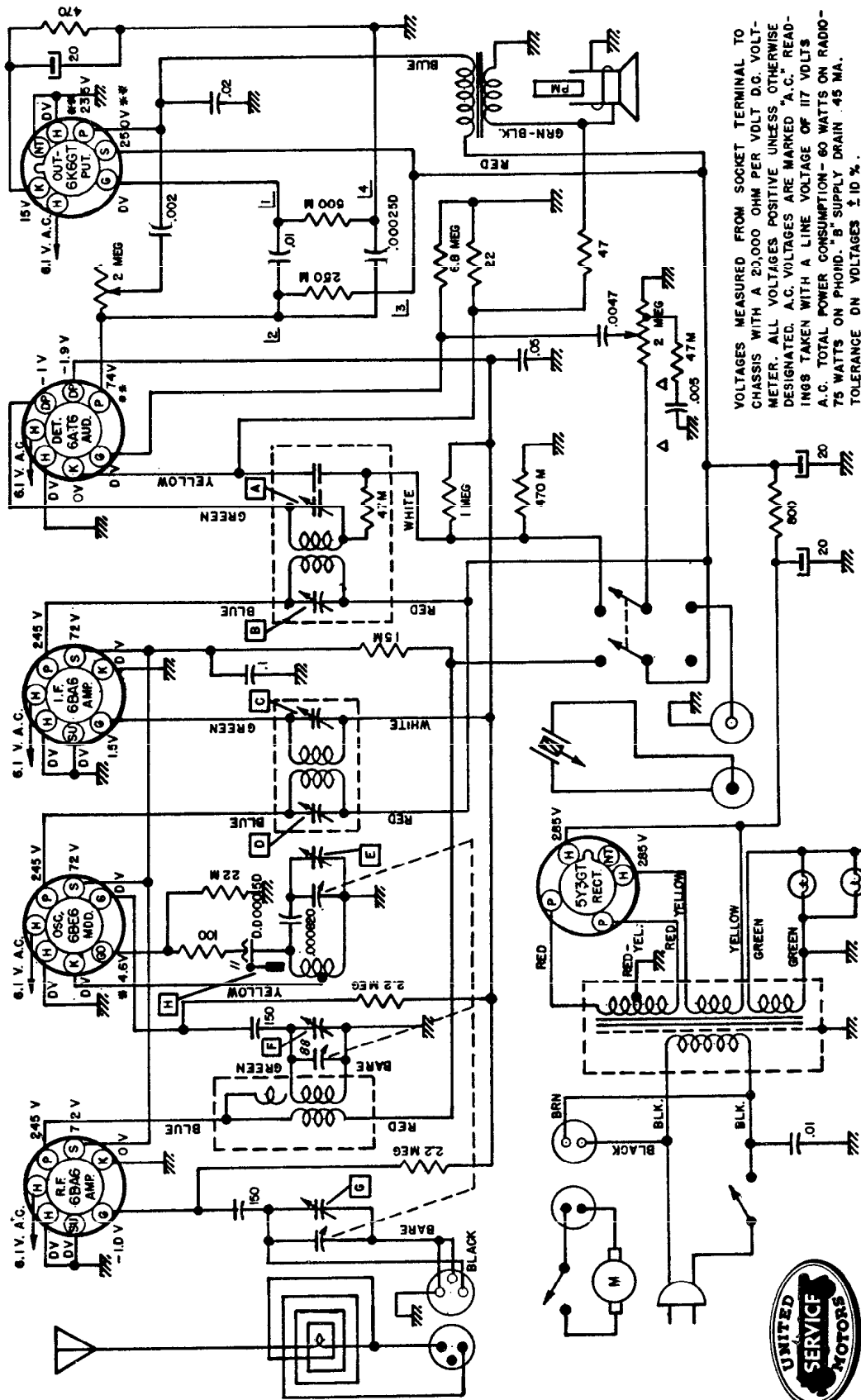

VOLTAGES MEASURED FROM SOCKET TERMINAL TO CHASSIS WITH A 20,000 OHM PER VOLT D.C. VOLT-METER. ALL VOLTAGES POSITIVE UNLESS OTHERWISE DESIGNATED. A.C. VOLTAGES ARE MARKED "A.C." READINGS TAKEN WITH A LINE VOLTAGE OF 117 VOLTS A.C. TOTAL POWER CONSUMPTION - 60 WATTS ON RADIO - 75 WATTS ON PHONO. "B" SUPPLY DRAIN .45 MA. TOLERANCE ON VOLTAGES ± 10%.

▲ VOLTAGE MEASURED WITH RECEIVER TUNED TO 1000 K.C.
 ▲ PARTS USED ONLY ON TUNE MODELS R-1246 AND R-1246
 ▲ THESE VOLTAGES ARE ABOUT 15% HIGHER USING "PHONO."

DELCO RADIO MODELS R-1244, R-1245 and R-1246



UNITED MOTORS SERVICE

DIVISION OF GENERAL MOTORS CORPORATION

I.F. 262 KC.

MANUAL OF 1949 MOST-OFTEN-NEEDED RADIO DIAGRAMS

UNITED MOTORS SERVICE

OLDSMOBILE DELUXE MODEL 982455

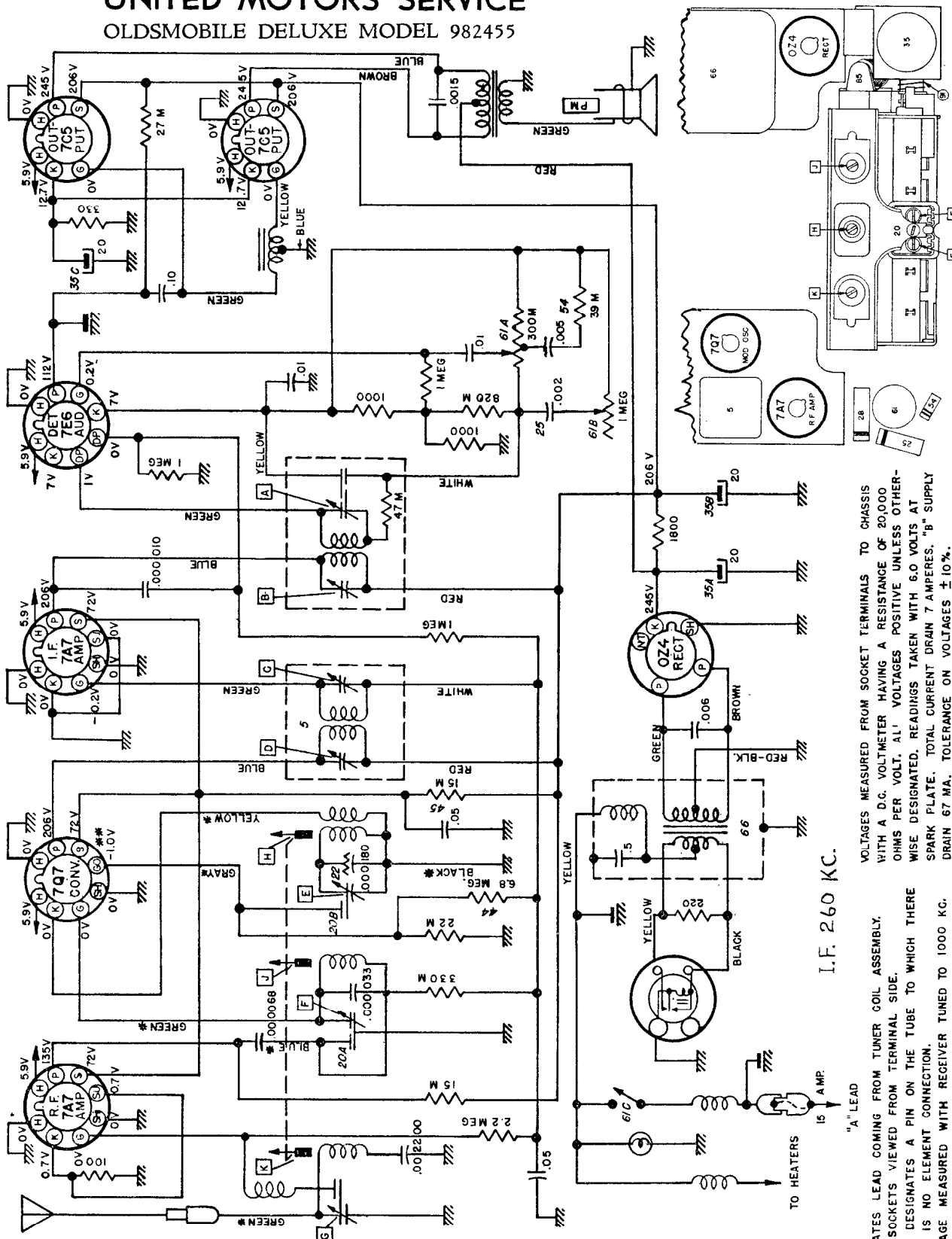

VOLTAGES MEASURED FROM SOCKET TERMINALS TO CHASSIS WITH A D.C. VOLTMETER HAVING A RESISTANCE OF 20,000 OHMS PER VOLT. ALL VOLTAGES POSITIVE UNLESS OTHERWISE DESIGNATED. READINGS TAKEN WITH 6.0 VOLTS AT SPARK PLATE. TOTAL CURRENT DRAIN 7 AMPERES. "B" SUPPLY DRAIN 67 MA. TOLERANCE ON VOLTAGES $\pm 10\%$.

I.F. 260 KC.

"A" LEAD

* INDICATES LEAD COMING FROM TUNER COIL ASSEMBLY. TUBE SOCKETS VIEWED FROM TERMINAL SIDE.

NT — DESIGNATES A PIN ON THE TUBE TO WHICH THERE IS NO ELEMENT CONNECTION.

** VOLTAGE MEASURED WITH RECEIVER TUNED TO 1000 KC.

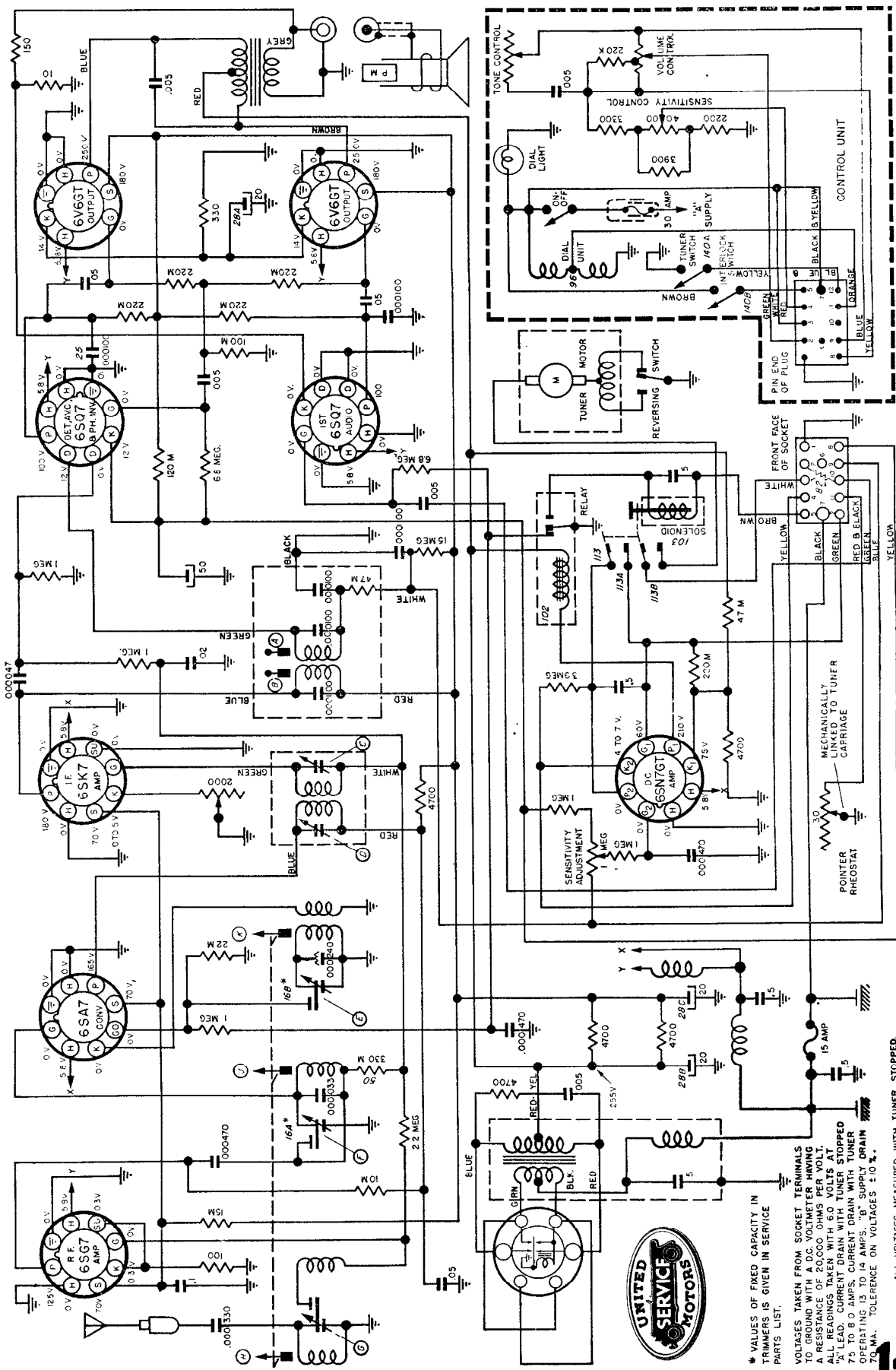

I.F. 260 KC.

DELCO MODEL R-705

UNITED MOTORS SERVICE

* VALUES OF FINED CAPACITY IN TRIMMERS IS GIVEN IN SERVICE PARTS LIST.

VOLTAGES TAKEN FROM SOCKET TERMINALS TO GROUND WITH A DC VOLTMETER HAVING A RESISTANCE OF 20,000 OHMS PER VOLT. ALL READINGS TAKEN WITH 150 VOLTS AT 75-80 PER CENT CURRENT DRAIN WITH TUNER OPERATING 13 TO 14 AMPS. 'B' SUPPLY DRAIN 70 MA. TOLERANCE ON VOLTAGES ±10 %.

ALL VOLTAGES MEASURED WITH TUNER STOPPED.



MANUAL OF 1949 MOST-OFTEN-NEEDED RADIO DIAGRAMS

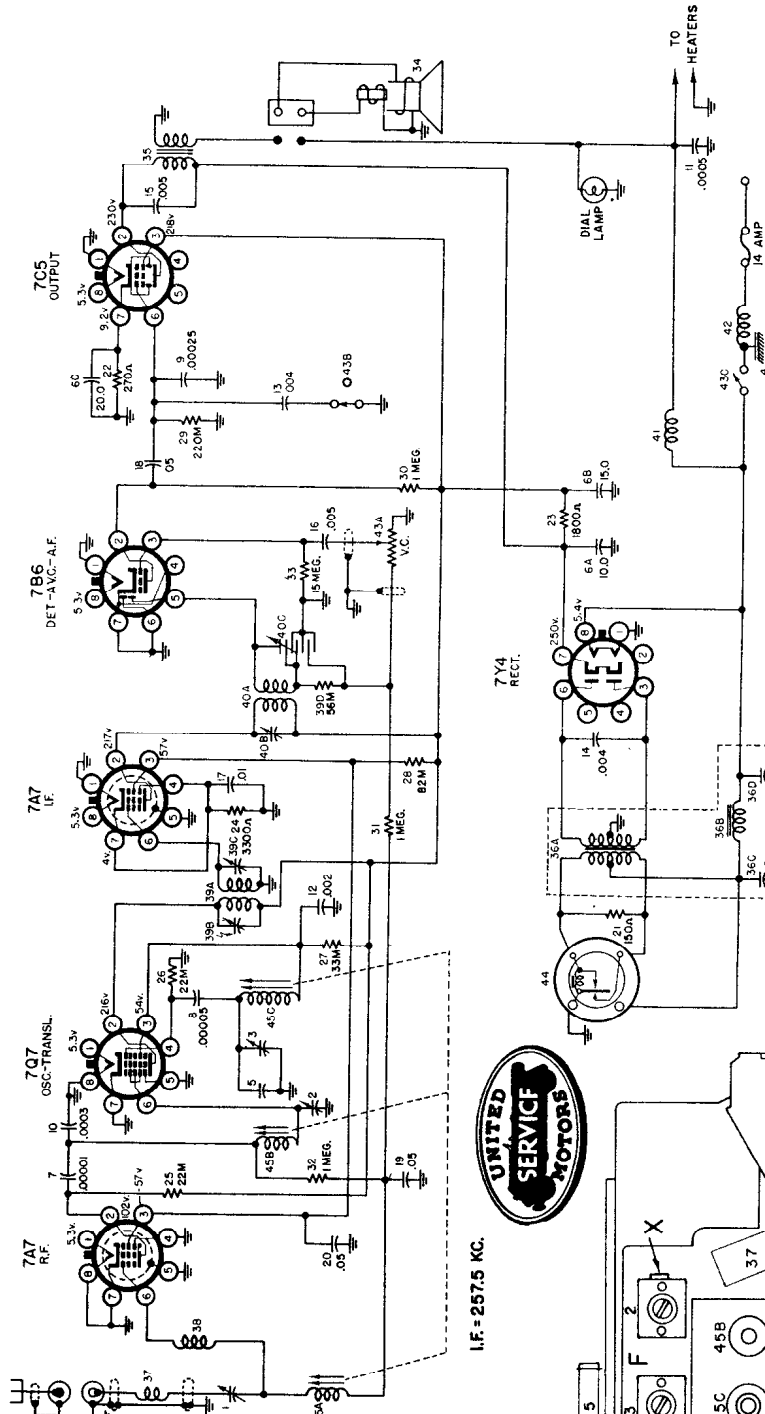

READINGS TAKEN FROM TUBE SOCKET CONTACTS TO GROUND WITH A 1000 OHMS PER VOLT D.C. VOLTMETER, "A" BATTERY - 60 VOLTS, CURRENT DRAIN - 7.2 AMPERES, "B" SUPPLY DRAIN - APPROX. 48 MA.

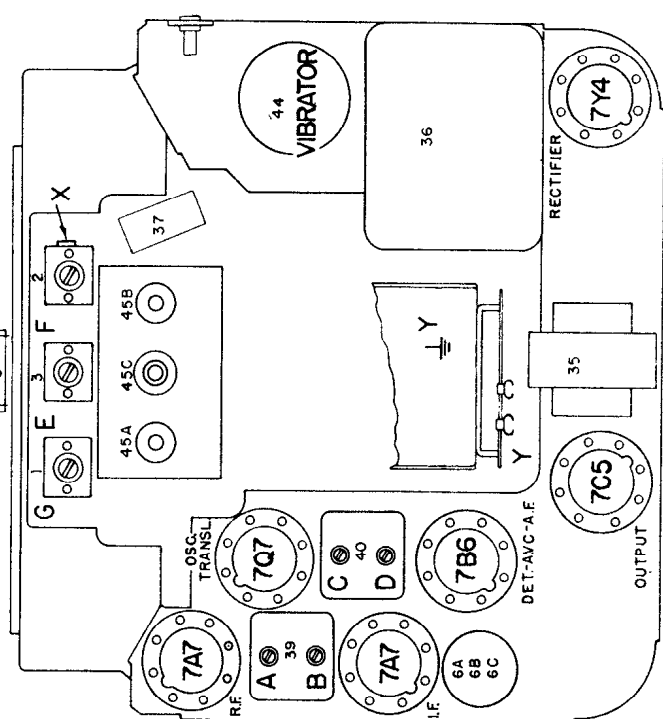

BOTTOM VIEW OF TUBE SOCKETS
 READINGS TAKEN FROM TUBE SOCKET CONTACTS TO GROUND WITH A 1000 OHMS PER VOLT D.C. VOLTMETER, "A" BATTERY - 60 VOLTS, CURRENT DRAIN - 7.2 AMPERES, "B" SUPPLY DRAIN - APPROXIMATELY 48 MA. ALL READINGS ± 10%.

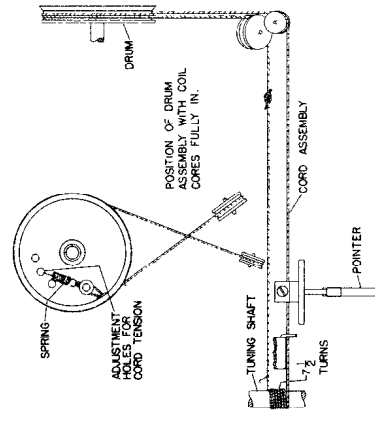

DIAL CORD HOOKUP

SOCKET VOLTAGES

UNITED MOTORS SERVICE
 DIVISION OF GENERAL MOTORS CORPORATION

Pontiac 984247

MANUAL OF 1949 MOST-OFTEN-NEEDED RADIO DIAGRAMS

7 TUBE AC (Including Rectifier) 2 BANDS

F.M. I.F. 10.7 MC.
A.M. I.F. 455 KC. 3.6.

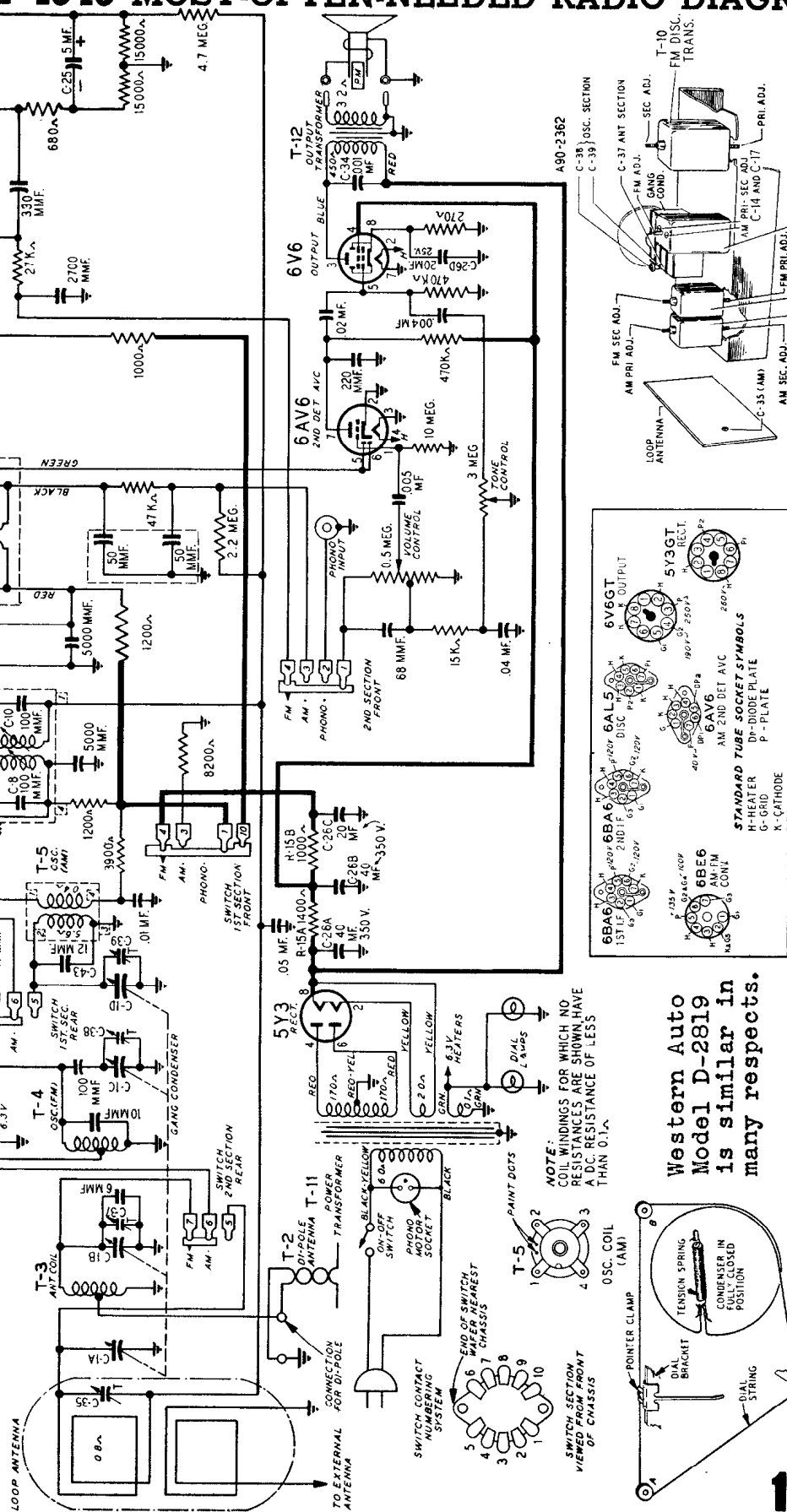

NOTE:
COIL WINDINGS FOR WHICH NO
RESISTANCES ARE SHOWN, HAVE
A D.C. RESISTANCE OF LESS
THAN 0.1.

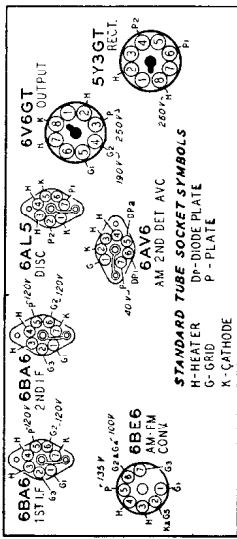

Western Auto
Model D-2819
is similar in
many respects.

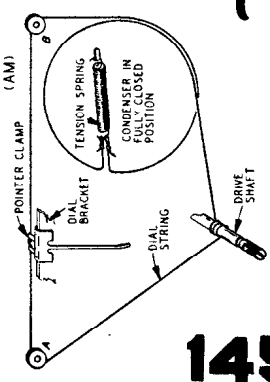

Jruetone Model D1836

SERIAL No. 105,927 UP

RADIO DIAGRAMS

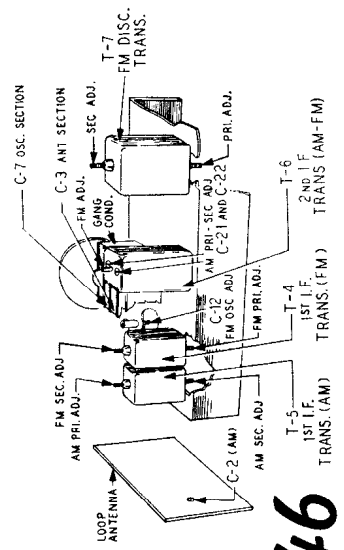
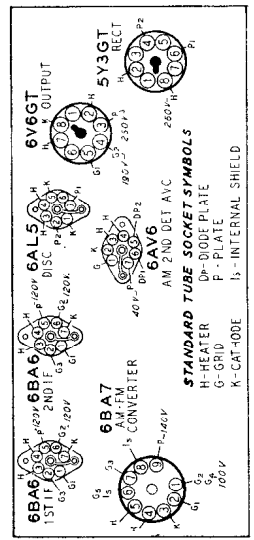
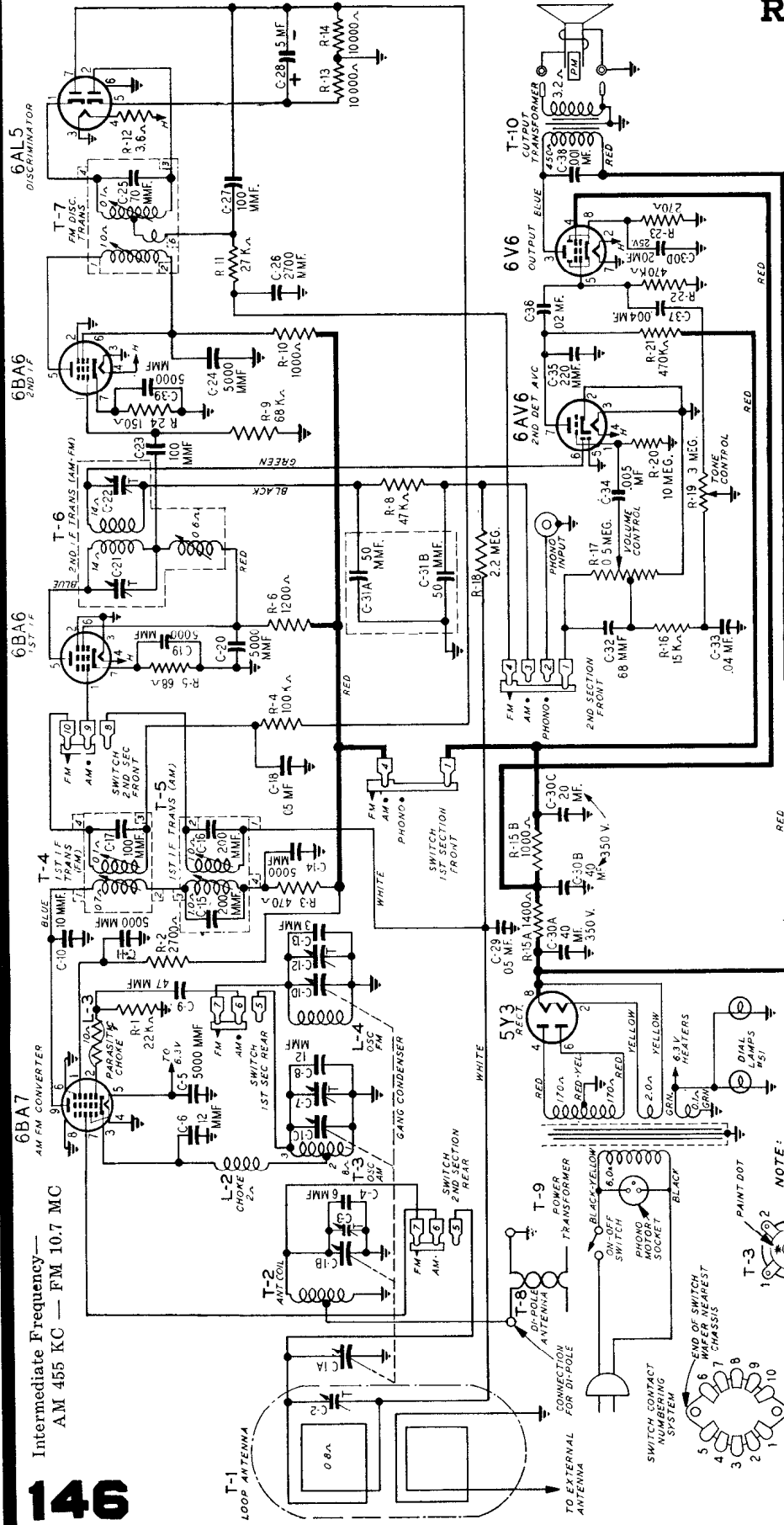

NOTE:
 COIL WINDINGS FOR WHICH NO RESISTANCES ARE SHOWN HAVE A D.C. RESISTANCE OF LESS THAN 0.1Ω

Intermediate Frequency—
 AM 455 KC — FM 10.7 MC

146

Truetone Model D1846

MANUAL OF 1949 MOST-OFTEN-NEEDED RADIO DIAGRAMS

WESTERN AUTO SUPPLY COMPANY

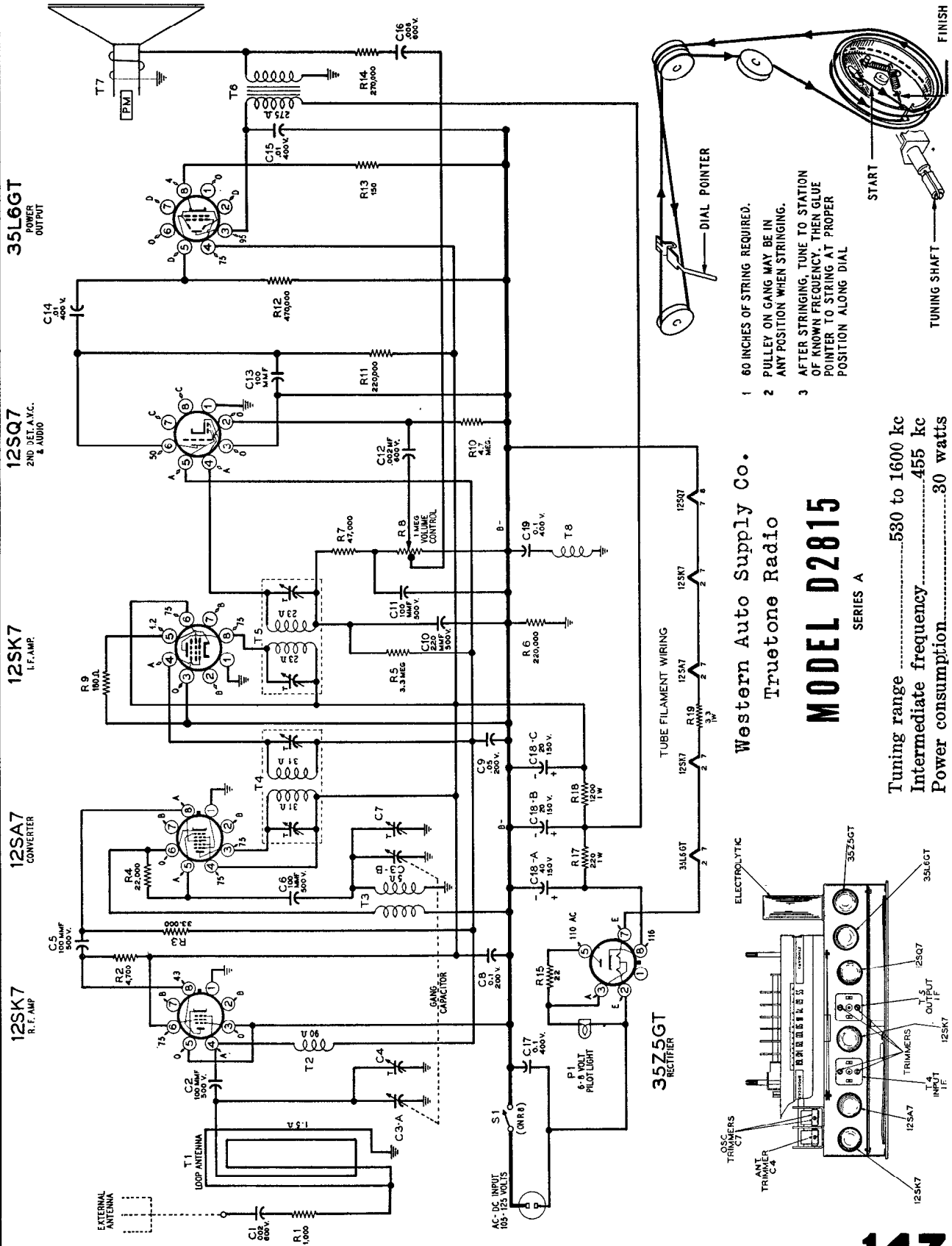

- 1 60 INCHES OF STRING REQUIRED.
- 2 PULLEY ON GANG MAY BE IN ANY POSITION WHEN STRINGING.
- 3 AFTER STRINGING, TUNE TO STATION OF KNOWN FREQUENCY. THEN GLUE POINTER TO STRING AT PROPER POSITION ALONG DIAL

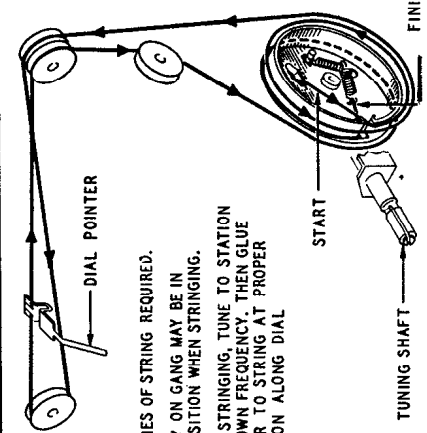

Western Auto Supply Co.
Truetone Radio

MODEL D2815

SERIES A

Tuning range	580 to 1600 kc
Intermediate frequency	455 kc
Power consumption	30 watts

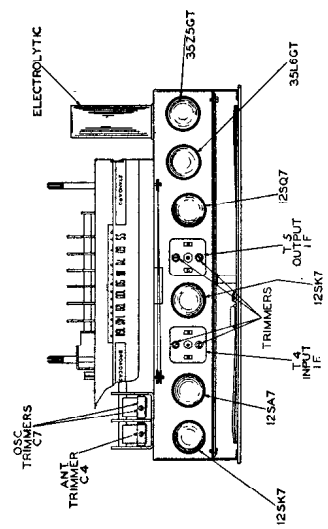

MANUAL OF 1949 MOST-OFTEN-NEEDED RADIO DIAGRAMS

WESTERN AUTO SUPPLY COMPANY

Jruetone Model D4832

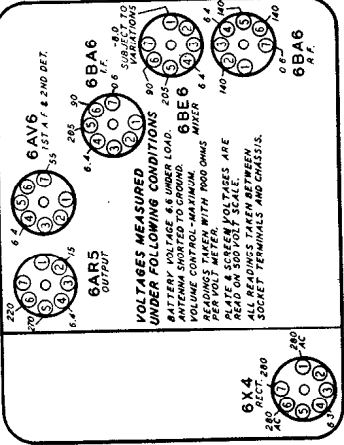
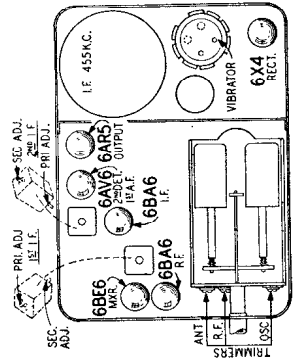
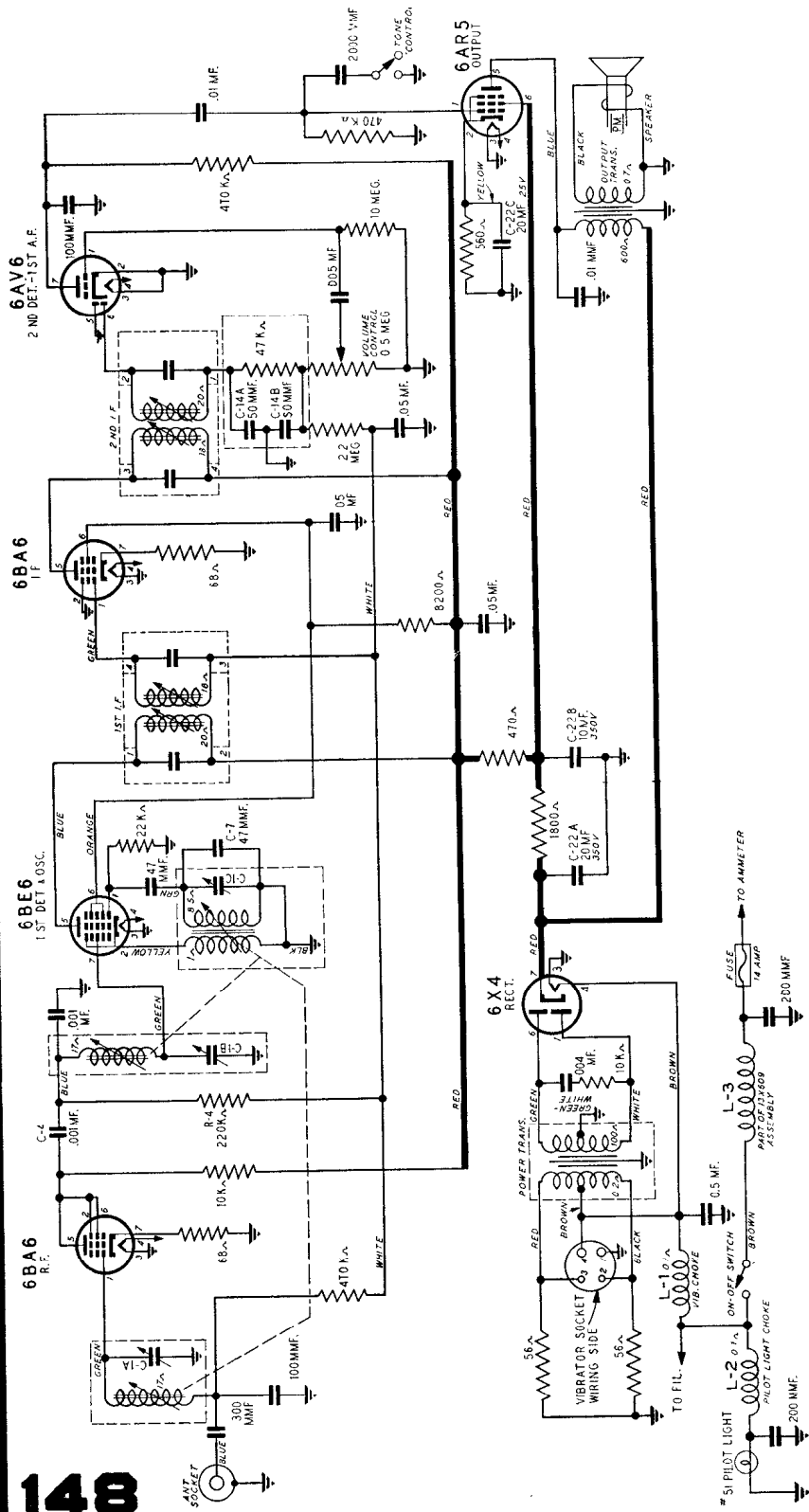

SPECIFICATIONS

- Power Consumption 6.6 Amperes at 6.6 Volts
- Power Output (6.6 Volts) 2.2 Watts Undistorted
..... 4.0 Watts Maximum
- Sensitivity 4 Microvolts at 1 Watt Output
- Selectivity 55 KC Broad at 1000 Times Signal
- Tuning Frequency Range 540 to 1600 KC
- Intermediate Frequency 455 KC
- Speaker 5 1/4" Dynamic

Westinghouse

RADIO • TELEVISION

H-164

H-166 & H-166A

H-167

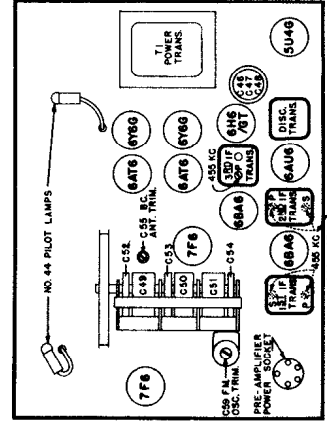
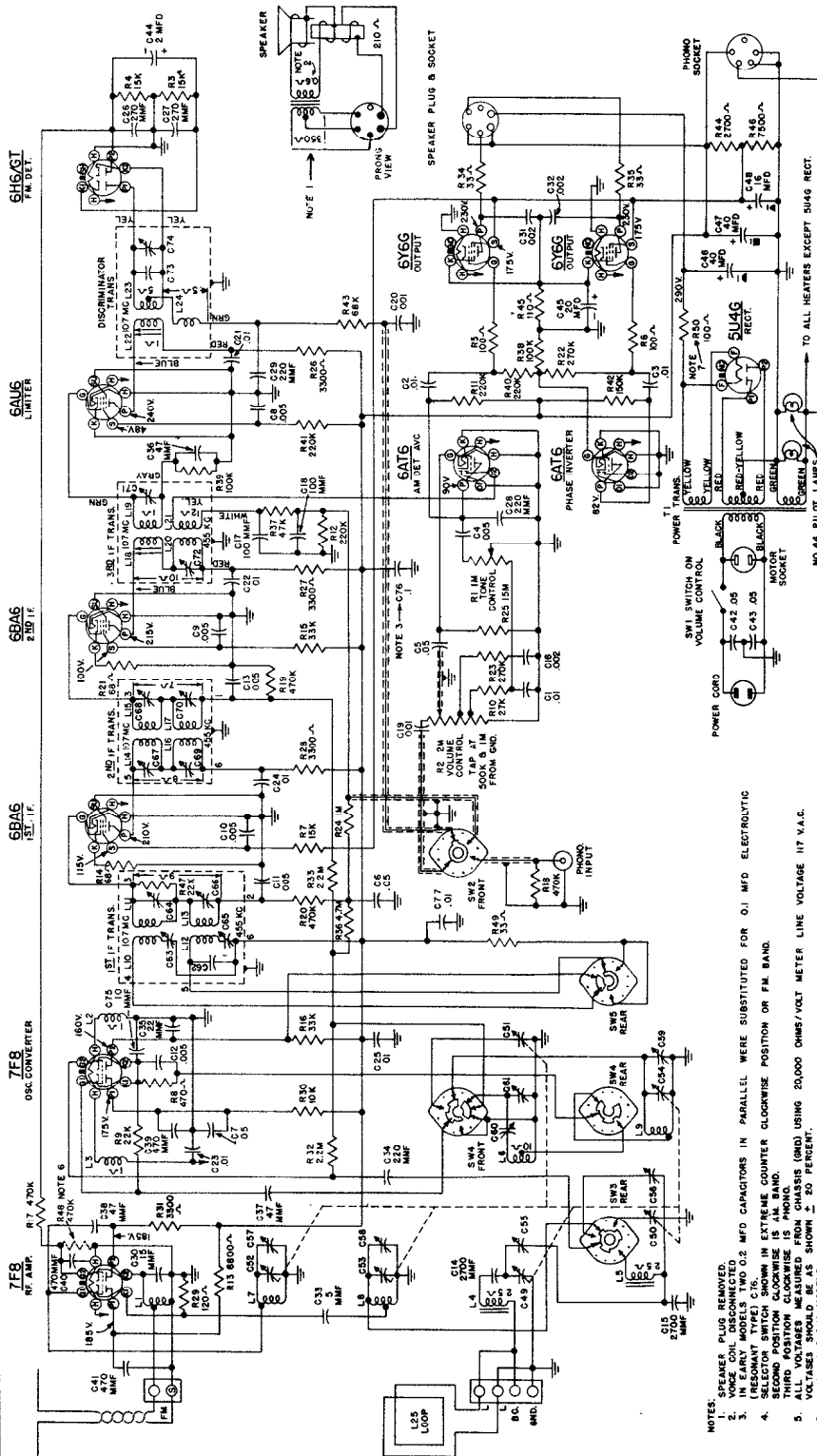

NOTE: A FEW EARLY MODELS (CHASSIS V-2119) HAD 1E1 AND 2E1 IF TRANSFORMER ADJUSTMENTS AS SHOWN BY DOTTED LINE.

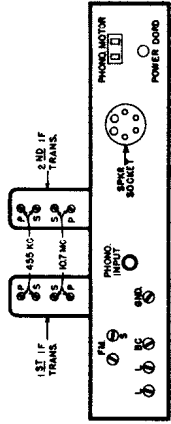

REAR VIEW OF MAIN CHASSIS

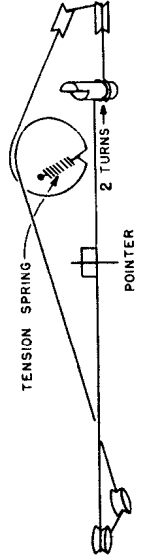

- NOTES:
1. SPEAKER PLUG REMOVED.
 2. VOICE COIL DISCONNECTED.
 3. IN EARLY MODELS TWO 0.2 MFD CAPACITORS IN PARALLEL WERE SUBSTITUTED FOR 0.1 MFD ELECTROLYTIC.
 4. SELECTOR SWITCH SHOWN IN EXTREME COUNTER CLOCKWISE POSITION ON FM BAND.
 5. SECOND POSITION CLOCKWISE IS AM BAND.
 6. THIRD POSITION CLOCKWISE IS PHONO INPUT.
 7. VOLTAGES SHOULD BE AS SHOWN ± 20 PERCENT.
 8. USED IN EARLY MODELS.
 9. USED ONLY WITH V-3586 POWER TRANSFORMER.

FREQUENCY RANGES:
 Standard Broadcast 540 to 1600 kc.
 Frequency Modulation 88 to 108 mc.

INTERMEDIATE FREQUENCIES:
 Amplitude Modulation 455 kc.
 Frequency Modulation 10.7 mc.

Westinghouse

RADIO · TELEVISION

MODEL H-165

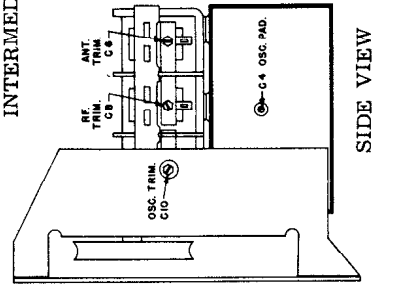
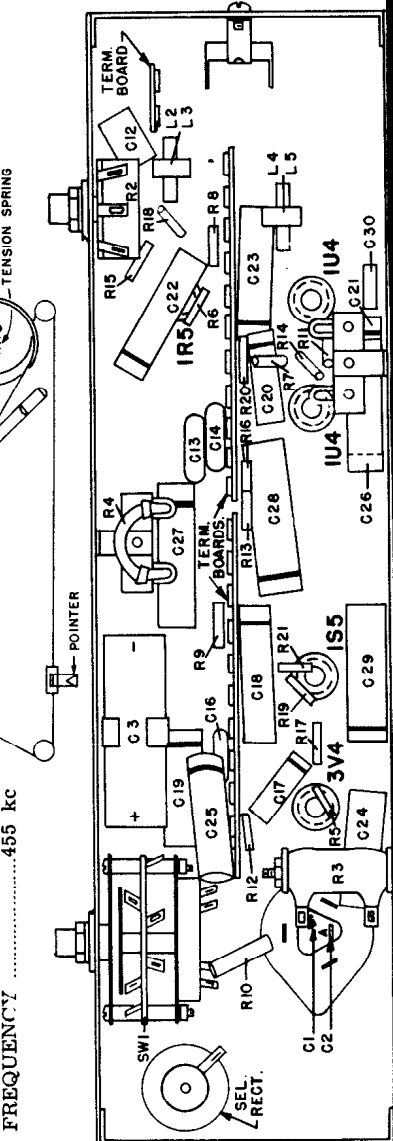
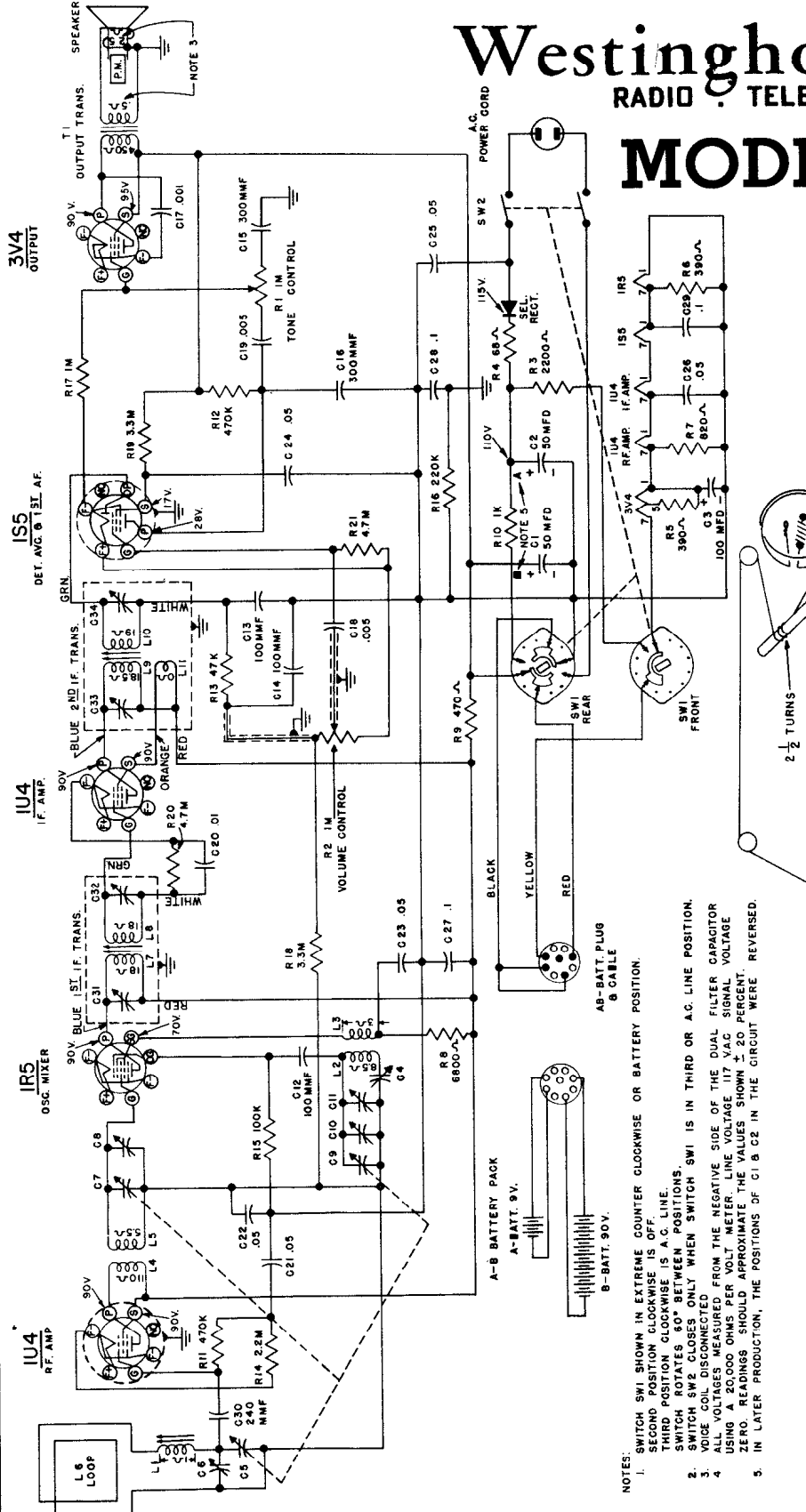

- NOTES:
1. SWITCH SW1 SHOWN IN EXTREME COUNTER CLOCKWISE OR BATTERY POSITION. SECOND POSITION CLOCKWISE IS OFF. THIRD POSITION CLOCKWISE IS A.C. LINE.
 2. SWITCH SW2 ROTATES 60° BETWEEN POSITIONS.
 3. SWITCH SW2 CLOSURES ONLY WHEN SWITCH SW1 IS IN THIRD OR A.C. LINE POSITION.
 4. VOICE COIL DISCONNECTED FROM THE NEGATIVE SIDE OF THE DUAL FILTER CAPACITOR ALL VOLTAGES MEASURED FROM THE NEGATIVE SIDE OF THE DUAL FILTER CAPACITOR ZERO ON OHMMETER. VOLTMETER LINE VOLTAGE 117 VAC SIGNAL VOLTAGE ZERO ON OHMMETER. VOLTAGE READINGS SHOULD APPROXIMATE THE VALUES SHOWN ± 20 PERCENT. IN LATER PRODUCTION, THE POSITIONS OF C1 & C2 IN THE CIRCUIT WERE REVERSED.

MANUAL OF 1949 MOST-OFTEN-NEEDED RADIO DIAGRAMS

Westinghouse Electric
Models H-185, H-195

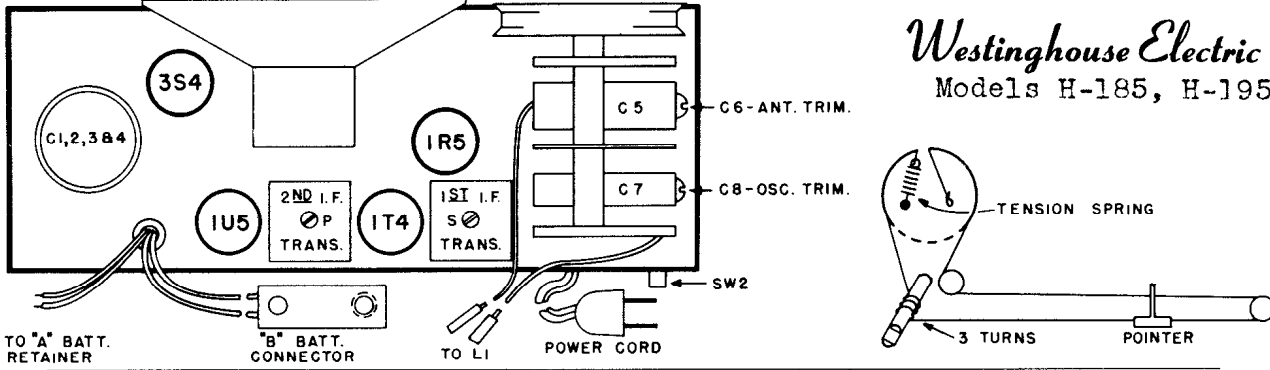

ALIGNMENT				
Step	Connect Signal Generator to -	Signal Generator Frequency	Radio Dial	Adjust for Maximum Output
1	Stator of R-F tuning capacitor (C5) through a 200 mmf capacitor	455 kc	455 kc	Pri. and Sec. of 2nd I-F trans.
2	Stator of R-F tuning capacitor (C5) through a 200 mmf capacitor	455 kc	455 kc	Pri. and Sec. of 1st I-F trans.
3	Recheck steps 1 and 2			
4	Radiated Signal	1615 kc	1615 kc	Oscillator Trimmer (C8)
5	Radiated Signal	1400 kc	1400 kc	R-F Trimmer (C6)

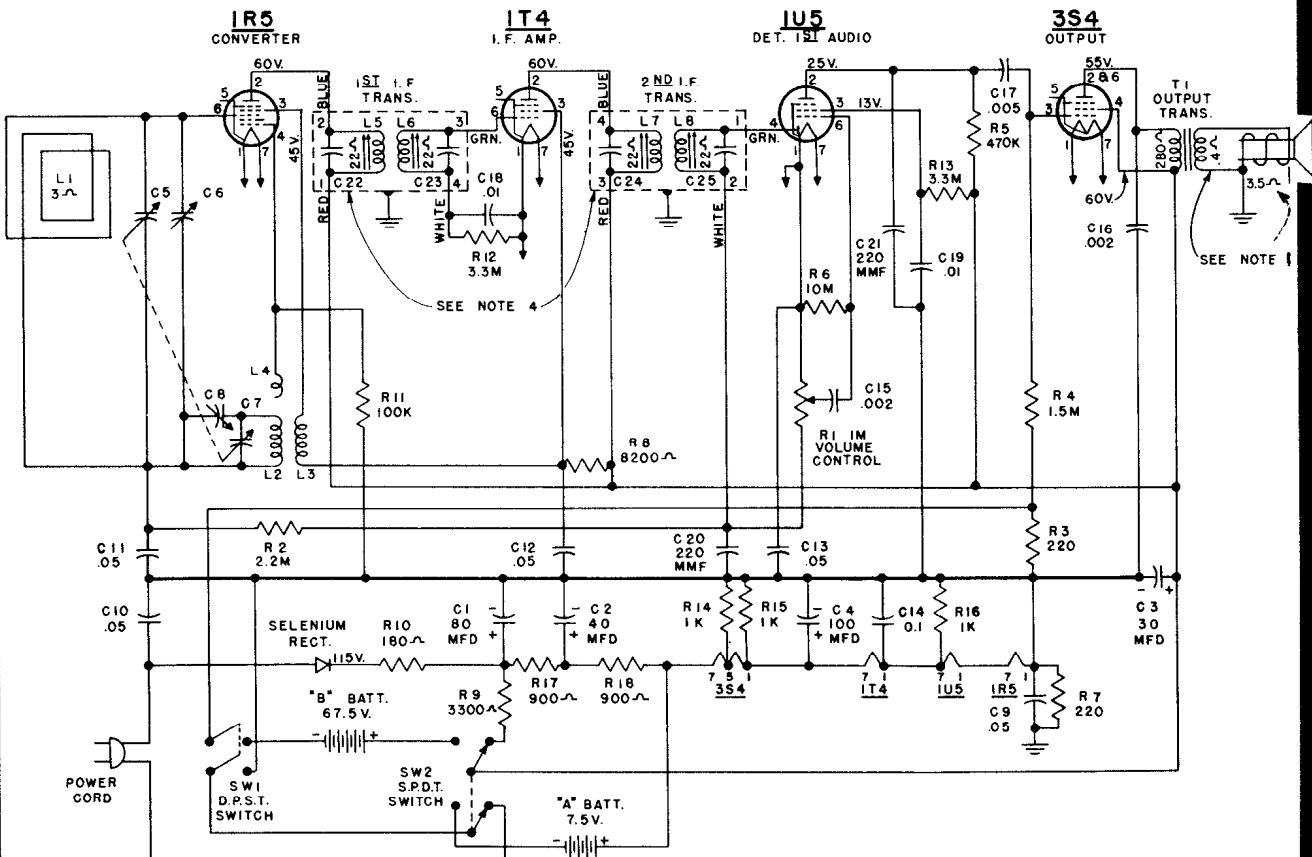

- NOTE:
1. VOICE COIL DISCONNECTED
 2. SWITCH NO. 2 SHOWN IN AC/DC POSITION.
 3. ALL VOLTAGES MEASURED FROM CIRCUIT (GND) USING A 20,000 OHMS/VOLT METER—LINE VOLTAGE AT H7 V.A.C. VOLTAGES SHOULD BE AS SHOWN ± 20 PER CENT.
 4. SOME MODELS MAY HAVE CAPACITOR TRIMMERS.

CHASSIS NO. V-2131 AND V-2131-I

MANUAL OF 1949 MOST-OFTEN-NEEDED RADIO DIAGRAMS

Westinghouse RADIO TELEVISION

MODEL H-188

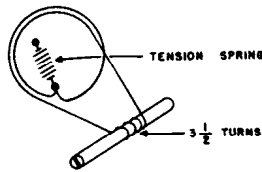

ALIGNMENT

Connect an output meter across the speaker voice coil.

While making the following adjustments, keep the volume control set for maximum output and the signal generator attenuated to avoid AVC action.

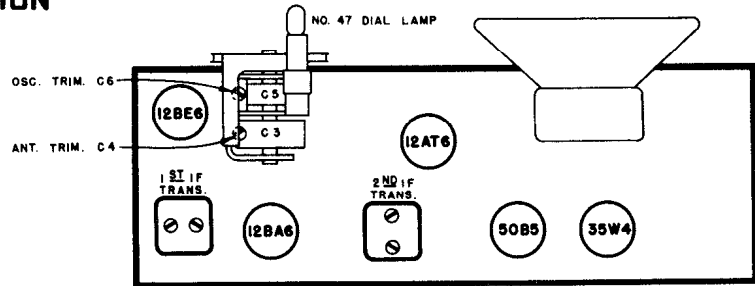

Step	Connect Signal Generator to —	Signal Generator Frequency	Radio Dial Setting	Adjust
1.	Stator of antenna tuning capacitor (C3) through a 0.1 mfd capacitor	455 kc	minimum capacity	Trimmers in 1st and 2nd I-F trans. for max. output
<p>NOTE: If the I-F transformers are badly mis-aligned, it may be impossible to obtain sufficient output using the above system. In this event, it will be necessary to align each transformer separately. Start with the last I-F transformer and work forward, connecting the signal generator to the control grid of the tube preceding the transformer under alignment.</p>				
2.	Recheck Step 1 adjustments.			
3.	Radiated signal (no actual connection)	1615 kc	minimum capacity	Osc. trimmer (C6) for max. output
4.	Radiated signal (no actual connection)	1400 kc	tune to signal	Ant. trimmer (C4) for max. output (rock-in adjustment)

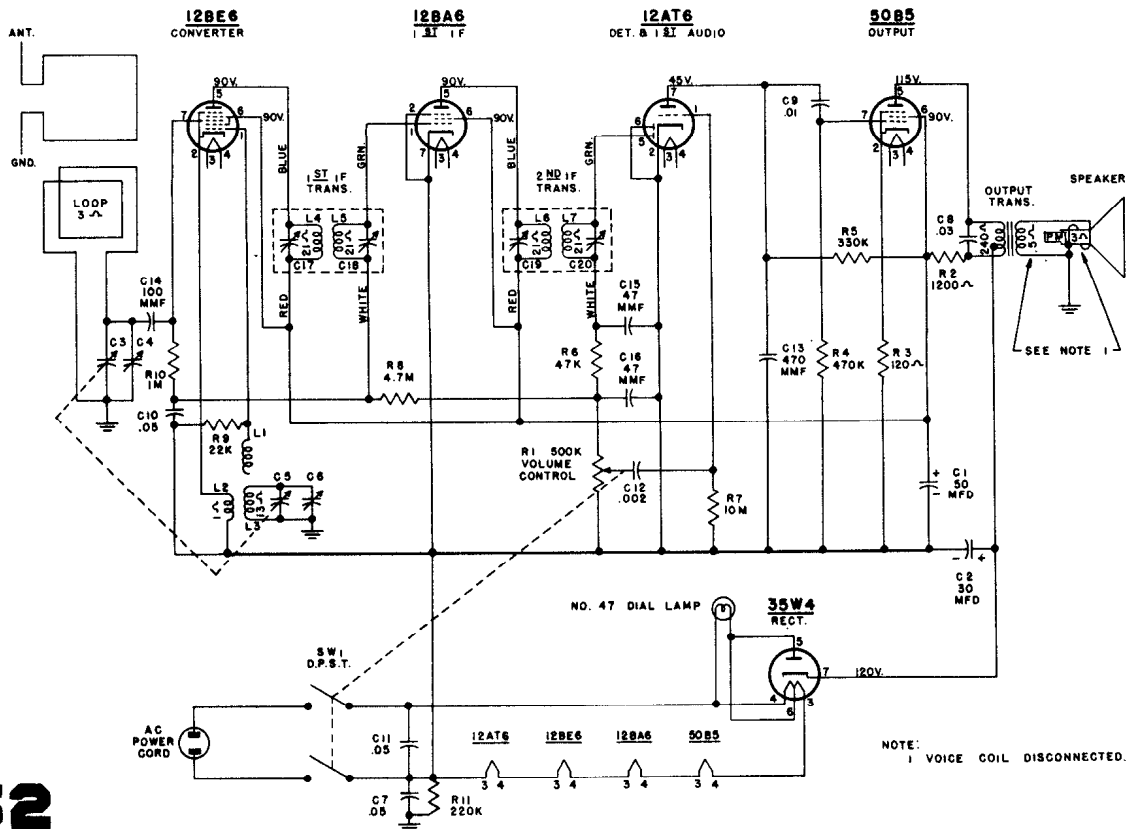

MANUAL OF 1949 MOST-OFTEN-NEEDED RADIO DIAGRAMS

Westinghouse Electric Corporation

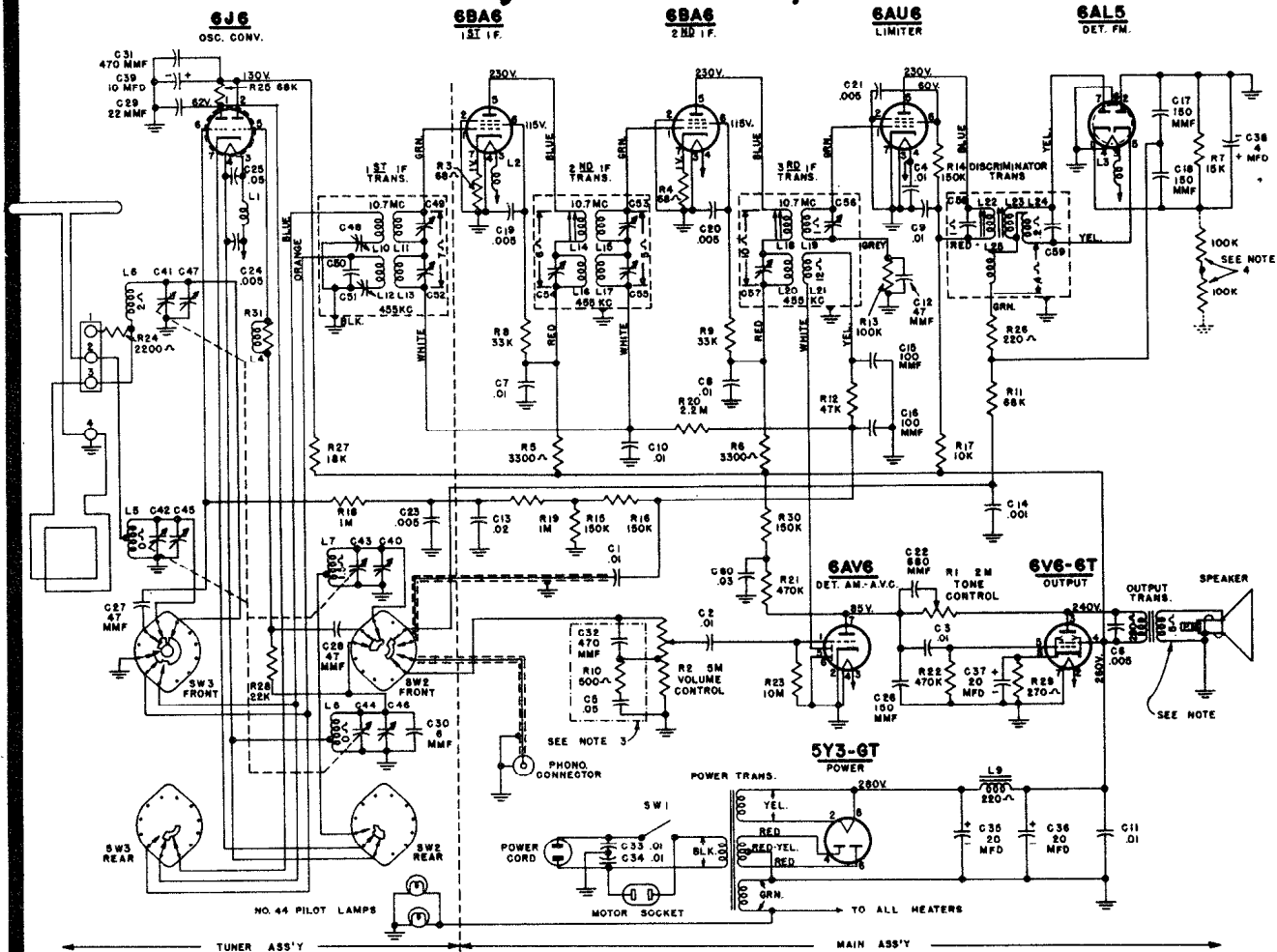

- NOTE:
1. SPEAKER DISCONNECTED.
 2. SELECTOR SWITCHES SW2 AND SW3 ARE SHOWN IN EXTREME COUNTER CLOCKWISE POSITION OR FM BAND. SECOND POSITION CLOCKWISE IS AM BAND. THIRD POSITION CLOCKWISE IS PHONO.
 3. NOT USED ON EARLY MODELS.
 4. TO BE INSTALLED TEMPORARILY BY SERVICE TECHNICIAN FOR ALIGNMENT PURPOSES ONLY.
 5. ALL VOLTAGES MEASURED FROM CHASSIS (GND.) USING 20,000 OHM/VOLT METER-LINE VOLTAGE 117 V.A.C. VOLTAGES SHOULD BE AS SHOWN ± 20 PER CENT.

Westinghouse RADIO TELEVISION

H-190, H-191, & H-191A

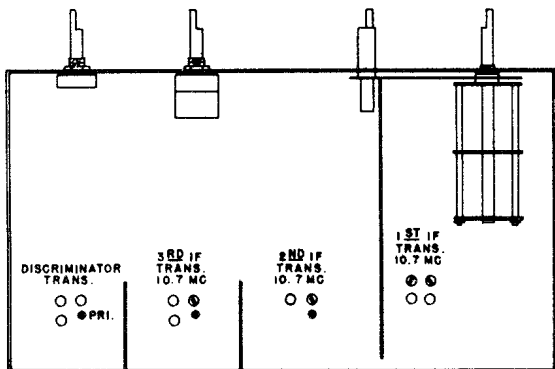

CHASSIS NO. V-2134
BOTTOM VIEW

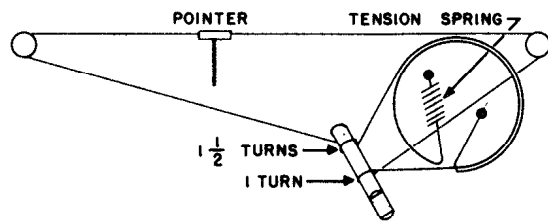
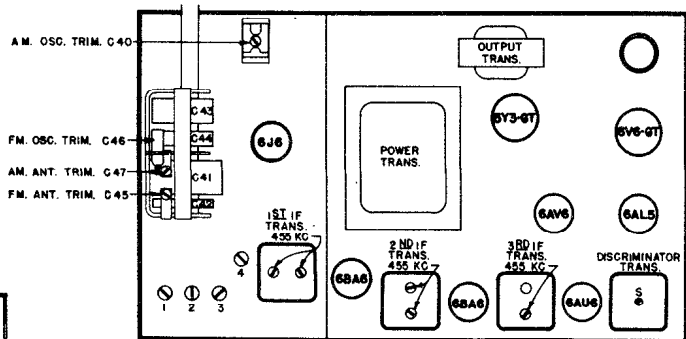

DIAL DRIVE

153

Westinghouse H-202 H-204

RADIO TELEVISION

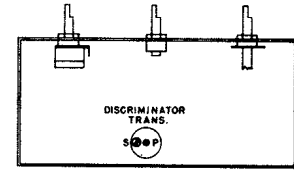
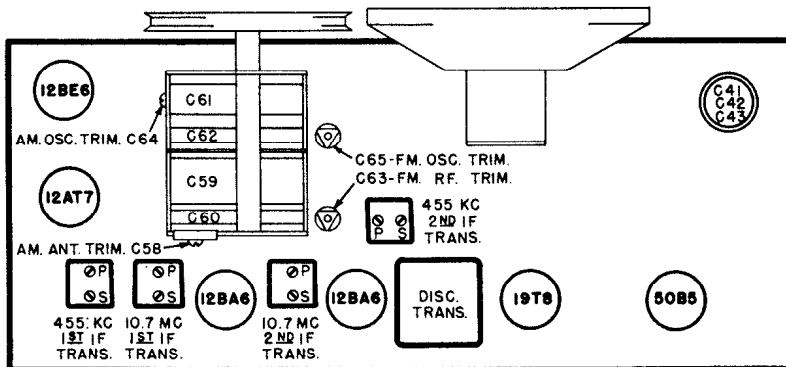

FIG. 1 - UNDER CHASSIS ADJUSTMENT

FREQUENCY RANGES:

Standard Broadcast ... 540 to 1600 kc.
 Frequency Modulation ... 88 to 108 mc.

INTERMEDIATE FREQUENCIES:

Amplitude Modulation 455 kc.
 Frequency Modulation 10.7 mc.

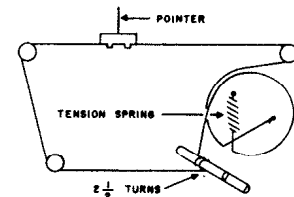
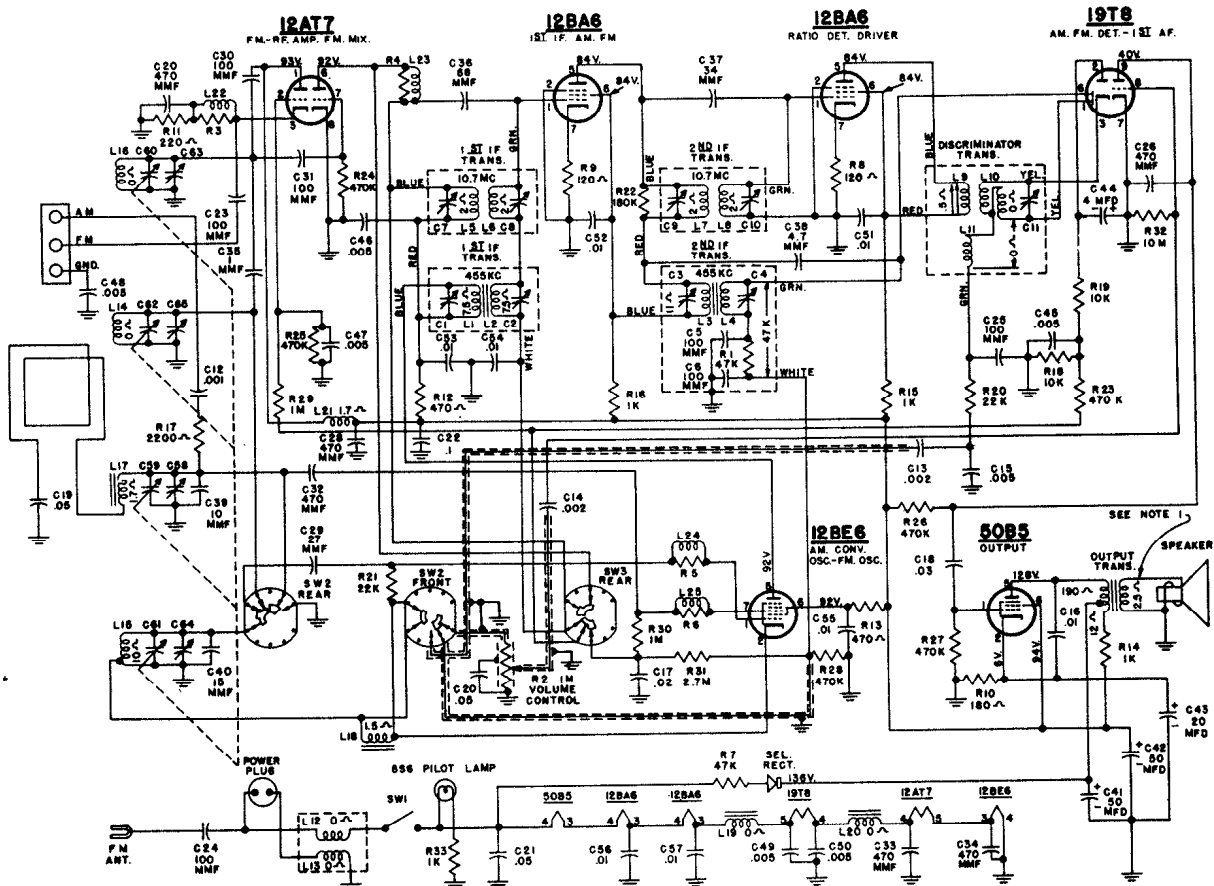

FIG. 2 - DIAL DRIVE



NOTE:

1. VOICE COIL DISCONNECTED.
2. SELECTOR SWITCH SW2-SW3 SHOWN IN EXTREME COUNTER CLOCKWISE POSITION OR AM BAND.
3. SECOND POSITION CLOCKWISE IS FM BAND.
3. ALL VOLTAGES MEASURED FROM CHASSIS (GND) USING 20,000 OHM/VOLT METER-LINE VOLTAGE 117 V.A.C. VOLTAGES SHOULD BE AS SHOWN ± 20 PER CENT.

MANUAL OF 1949 MOST-OFTEN-NEEDED RADIO DIAGRAMS

MODELS 5D811 CHASSIS 5E01

Zenith Radio Corp.

(Model 5D810, Chassis 5E02 is similar to Model 5D811, Chassis 5E01 shown here.)

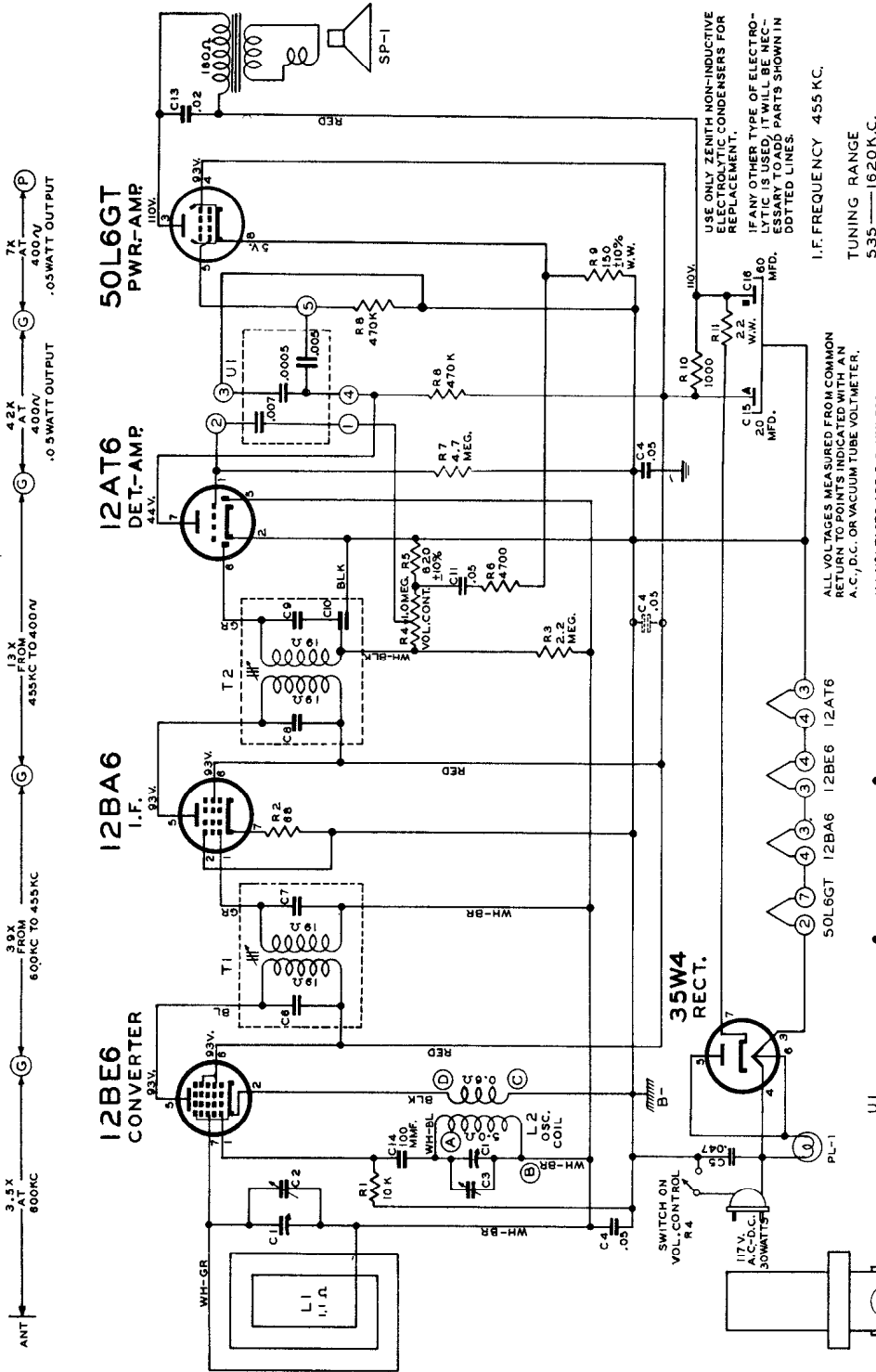
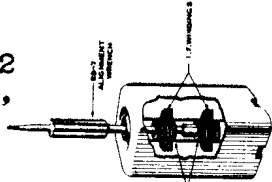
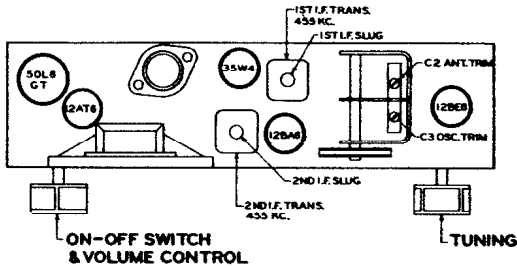

USE ONLY ZENITH NON-INDUCTIVE ELECTROLYTIC CONDENSERS FOR REPLACEMENT.
IF ANY OTHER TYPE OF ELECTROLYTIC IS USED, IT WILL BE NECESSARY TO ADD PARTS SHOWN IN DOTTED LINES.
I.F. FREQUENCY 455 KC.
TUNING RANGE 535 — 1620 K.C.

ALL VOLTAGES MEASURED FROM COMMON RETURN TO POINTS INDICATED WITHIN A.C./D.C. OR VACUUM TUBE VOLT-METER, UNLESS OTHERWISE SPECIFIED.
ALL RESISTORS ARE D.C. UNLESS OTHERWISE SPECIFIED.
ALL RESISTORS ±20% TOLERANCE UNLESS OTHERWISE SPECIFIED.

ALIGNMENT PROCEDURE

OPERATION	CONNECT OSCILLATOR TO ANTENNA	DUMMY ANTENNA	INPUT SIG. FREQUENCY	SET DIAL AT	TRIMMERS	PURPOSE
1	Converter Grid	.5 Mfd.	455 Kc.	600 Kc.	Adjust Primary & Secondary Slugs C-3	For I. F. Alignment
2	One Turn Loop Coupled Loosely to Wave Magnet	--	1600 Kc.	1600 Kc.	C-3	Set Oscillator to Dial Scale.
3	--	--	1400 Kc.	1400 Kc.	C-2	Align Antenna Stage

DENOTES CHASSIS
DENOTES COMMON RETURN

ON MULTIPLE SECTION CAPACITORS LEADS LINE UP ACCORDING TO THE PART NUMBER AS SHOWN.

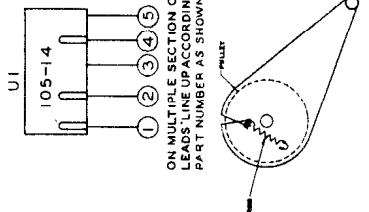

MANUAL OF 1949 MOST-OFTEN-NEEDED RADIO DIAGRAMS

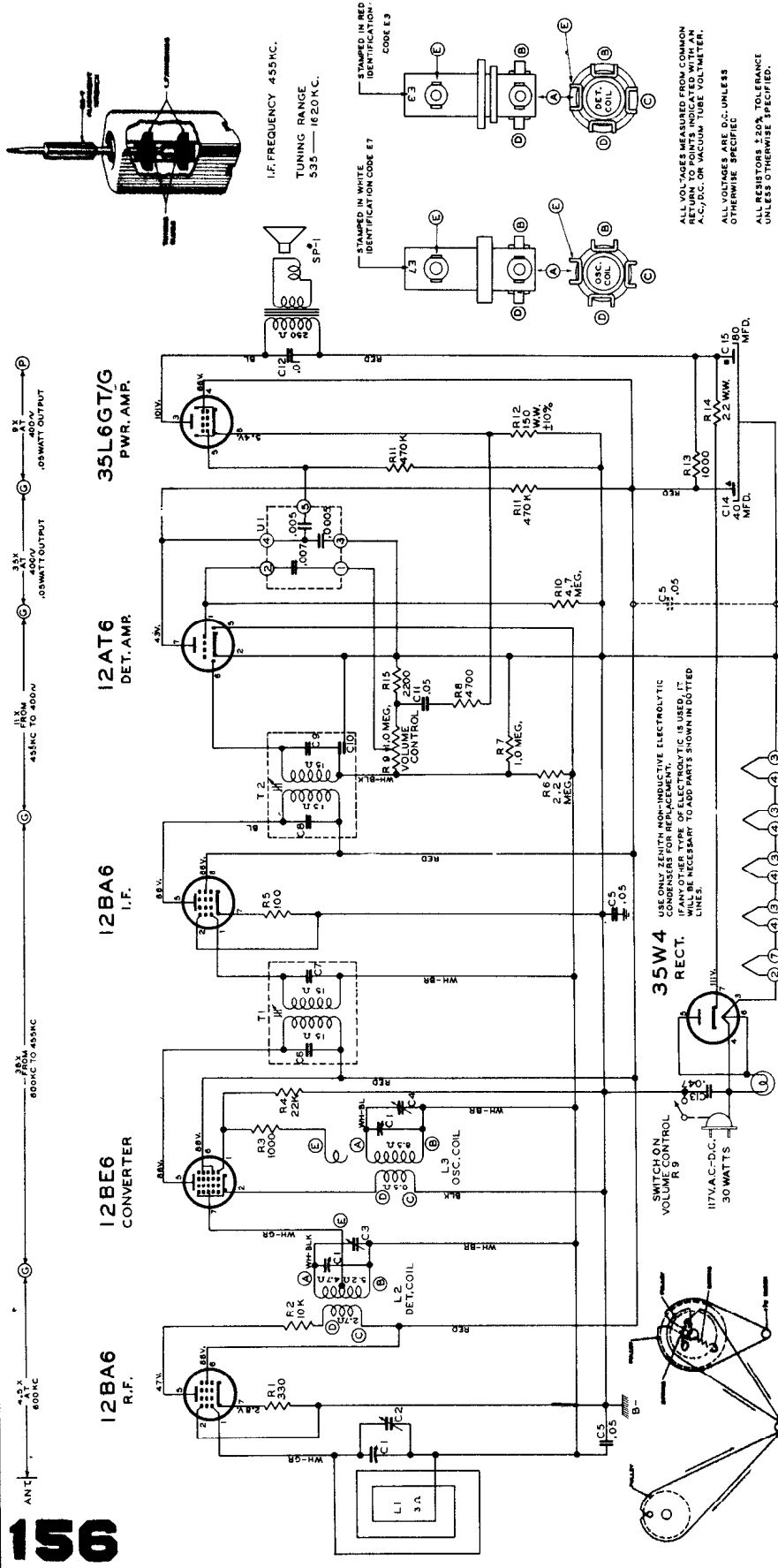

ALIGNMENT PROCEDURE

OPERATION	CONNECT OSCILLATOR TO ANTENNA	DUMMY FREQUENCY	INPUT SIG. FREQUENCY	SET DIAL AT	TRIMMERS	PURPOSE
1	Converter Grid	.5 Mc.	455 Kc.	600 Kc.	Adjust Primary & Secondary Slugs	For I.F. Alignment
2	Single Turn Loosely Coupled to Wave Magnet	--	1600 Kc.	1600 Kc.	C-4	Set Oscillator to Dial Scale.
3			1400 Kc.	1400 Kc.	C-3	Detector Alignment
4			1400 Kc.	1400 Kc.	C-2	Antenna Alignment

MODELS 6D815 CHASSIS 6E05 Zenith Radio

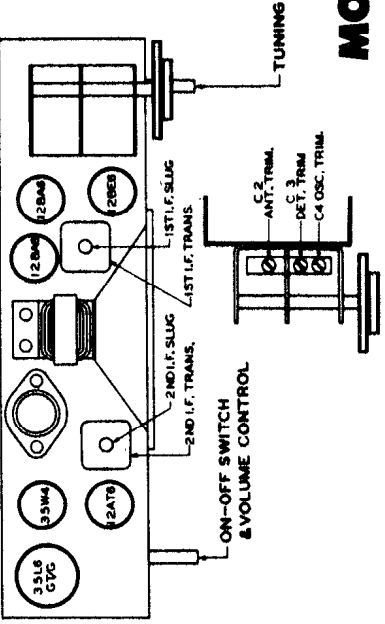

ON MULTIPLE SECTION CAPACITORS TO THE PART NUMBER AS SHOWN.

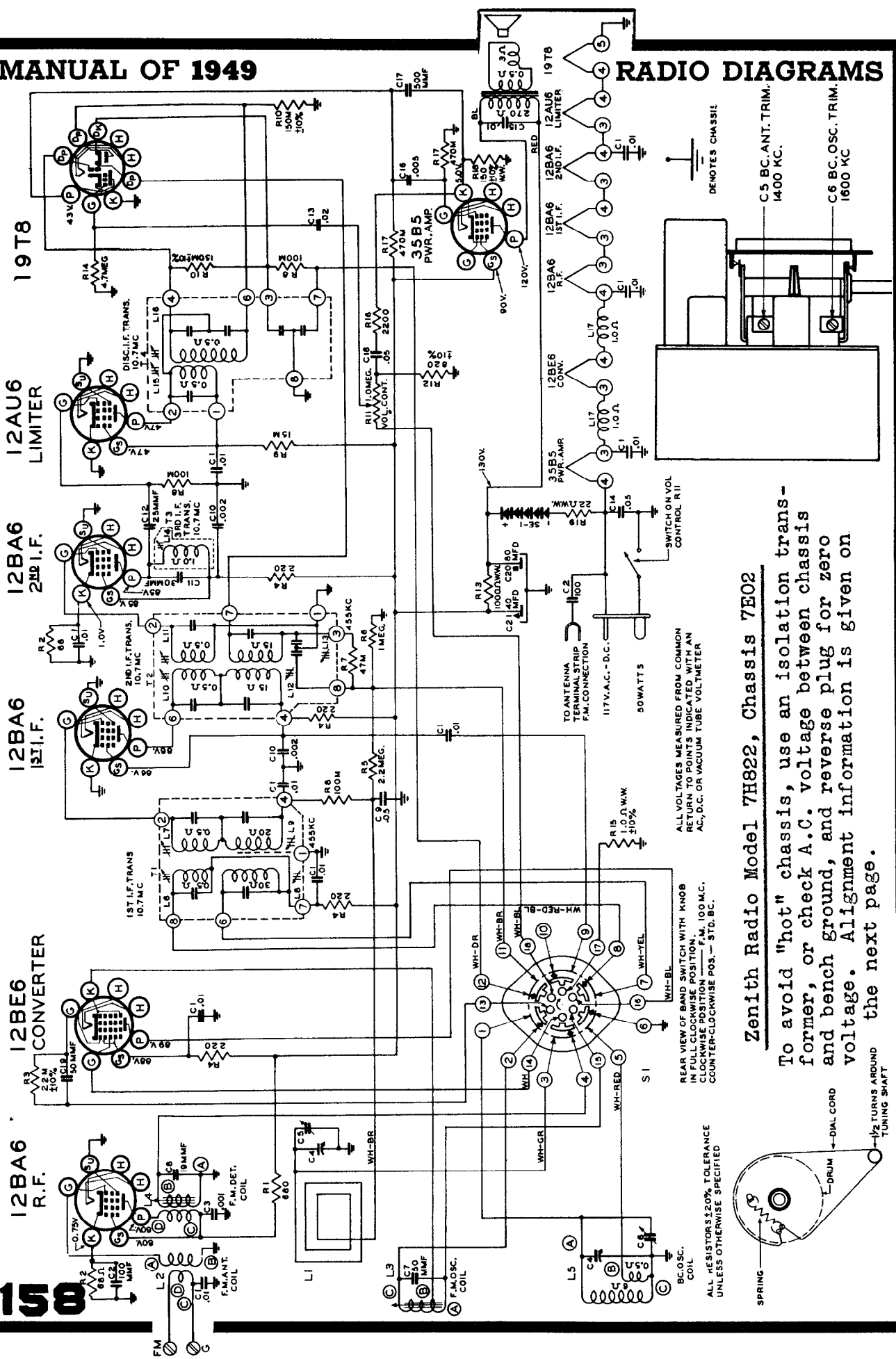

Zenith Radio Model 7H822, Chassis 7E02

To avoid "hot" chassis, use an isolation transformer, or check A.C. voltage between chassis and bench ground, and reverse plug for zero voltage. Alignment information is given on the next page.

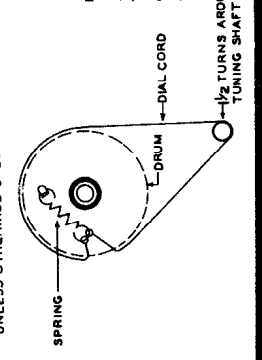

MANUAL OF 1949 MOST-OFTEN-NEEDED RADIO DIAGRAMS

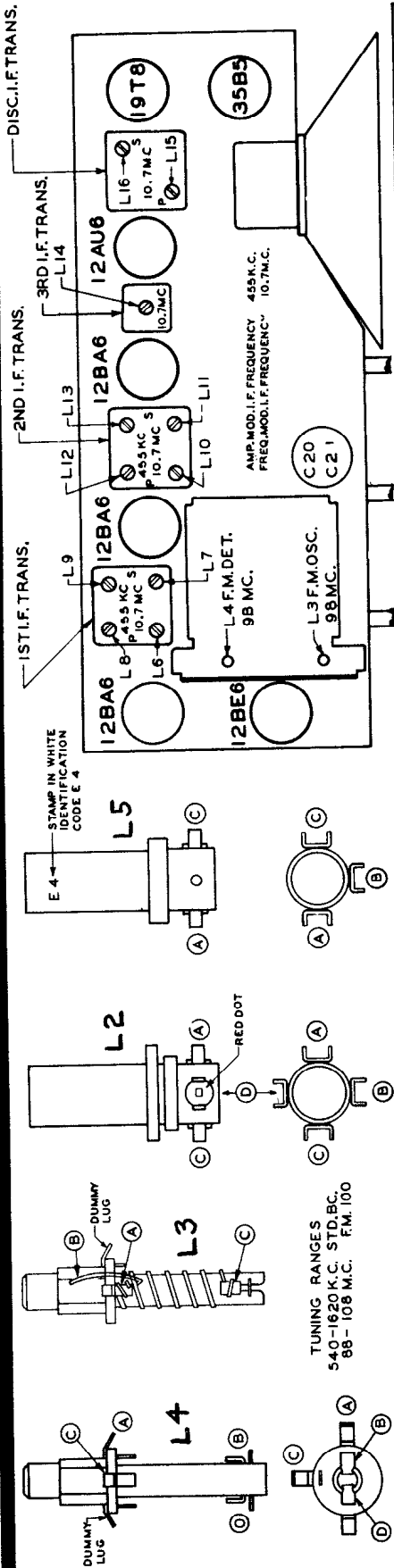

Operation	Connect Oscillator to	Dummy Antenna	Input Signal Frequency	Band	Sat Dial To	Adj. Trimmers	Purpose
1	Pin 7 12BE6 Converter 2 turns loosely cpl'd. to wavenagnet	.05 Mfd.	455 Kc. Modulated	BC	600 Kc.	L8, 9, 12, 13	Align I. F. channel for maximum output.
2	2 turns loosely cpl'd. to wavenagnet		1600 Kc. Modulated	BC	1600 Kc.	C6	Set oscillator to dial scale.
3	2 turns loosely cpl'd. to wavenagnet		1400 Kc. Modulated	BC	1400 Kc.	C5	Align antenna stage.
4 (a)	Pin 1 (grid) on 12AU6 limiter.	.05 Mfd.	10.7 Mc. Unmodulated	FM		L15 coil slug	Align primary of discriminator for maximum reading.
5 (b)	Pin 1 (grid) on 12AU6 limiter.	.05 Mfd.	10.7 Mc. Unmodulated	FM		L16 coil slug	Adjust secondary of discriminator for zero reading.
6 (c)	Pin 1 (grid) on 12BA6 2nd IF.	.05 Mfd.	10.7 Mc. Unmodulated	FM		L14 Prim. of 3rd IF trans.	Align 3rd IF transformer for maximum reading.
7 (c)	Pin 1 (grid) on 12BA6 1st IF.	.05 Mfd.	10.7 Mc. Unmodulated	FM		L10 and L11 Prim. and Sec. of 2nd IF transformer	Align 2nd IF transformer for maximum reading.
8 (c)	Pin 7 (grid) on 12BE6 converter tube socket.	.05 Mfd.	10.7 Mc. Unmodulated	FM		L6 and L7 Prim. and Sec. of 1st IF transformer.	Align 1st IF transformer for maximum reading.
9 (c)	Antenna Post FM (Re-move line ant.)	270 ohms	98 Mc. Unmodulated	FM	98 Mc.	L3 Osc. Coill Slug	Set Oscillator to dial scale.
10 (c) (d)		270 ohms	98 Mc. Unmodulated	FM	98 Mc.	L4 Det. Coill Slug	Align det. stage to maximum reading.

A vacuum tube voltmeter with an isolation resistor of 2,000,000 ohms in series with the hot lead will serve for FM adjustments. An AC output meter connected across the primary or secondary of the output transformer will be satisfactory for all AM adjustments. The signal generator output should be kept just high enough to get an indication on the meter.

(a) Vacuum Tube Voltmeter Lug 6 on discriminator transformer to chassis (half discriminator load).
 (b) Vacuum Tube Voltmeter Lug 3 on discriminator transformer to chassis (full discriminator load).
 (c) Vacuum Tube Voltmeter from Limiter Grid to Chassis.
 (d) Loosen Slugs by applying a hot iron to the cement.

MODEL 7H822
CHASSIS 7E02

6K6GT
PWR.-AMP.

6SQ7GT
DET.-AMP.

6SK7
I.F.

6SA7GT
CONVERTER

6SK7GT
R.F.

I.F. FREQUENCY 455K.C.
TUNING RANGE
535 — 1620K.C.

160

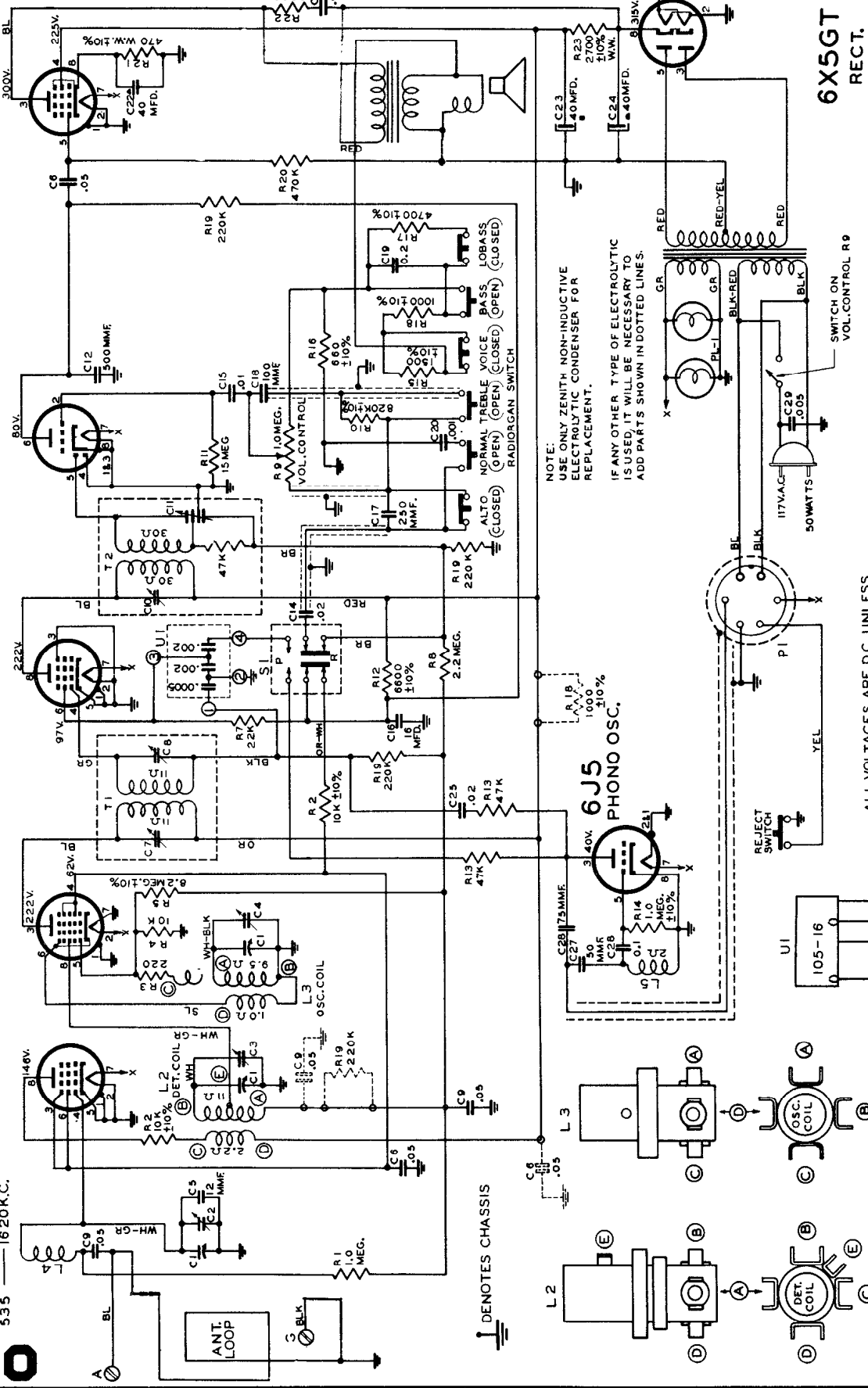

NOTE:
USE ONLY ZENITH NON-INDUCTIVE
ELECTROLYTIC CONDENSER FOR
REPLACEMENT.
IF ANY OTHER TYPE OF ELECTROLYTIC
IS USED, IT WILL BE NECESSARY TO
ADD PARTS SHOWN IN DOTTED LINES.

ALL VOLTAGES ARE D.C. UNLESS
OTHERWISE SPECIFIED

ON TRIPLE CAPACITORS LEADS
LINEUP ACCORDING TO THE
PART NUMBER AS SHOWN.

Zenith Radio Corp.

MODEL 7R887
CHASSIS 7E22

