

PERPETUAL

TROUBLE SHOOTER'S MANUAL

Reg. U. S. Pat. Off.

VOLUME XXIII



JOHN F. RIDER PUBLISHER, INC.

480 Canal Street



New York 13, N. Y.

MODELS 5L21, 5L22,
5L23, Ch. 5L2

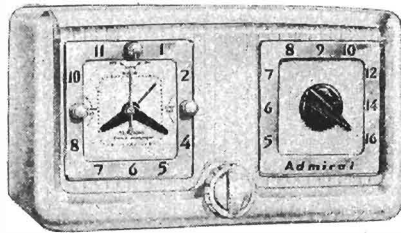

TO REMOVE CLOCK FROM CABINET

(Radio chassis need not be removed when removing clock)

1. Remove the back from radio cabinet.
2. Remove the clock plug from the socket on top of the radio chassis, by removing screw from top of plug and gently prying plug out from socket.
3. Remove the 2 nuts which hold the clock back cover to the clock.
4. Pull the clock out through the front of the cabinet.

**OPERATING RADIO WHEN CLOCK IS
REMOVED FROM CABINET**

If the radio must be operated without the clock, a wire jumper must be connected between contacts 1 and 4 on socket M2 to complete the circuit.

TUBE AND TRIMMER LOCATION

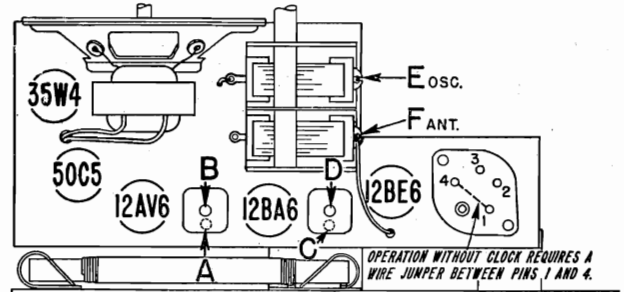

Adjustments A and C made from underside of chassis.

DIAL STRINGING AND POINTER SETTING

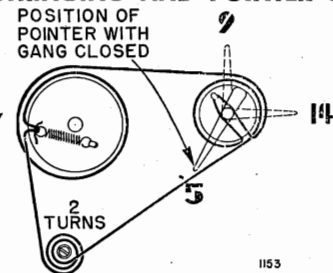

Dial stringing and pointer with solid lines shown with gang closed. Dashed line pointer positions (1400 KC and 900 KC) shown when tuning condenser is tuned to generator signal.

ALIGNMENT PROCEDURE

- Connect a wire jumper between contacts 1 and 4 on clock socket (M2) as shown in illustration.
 - Turn receiver volume control full on (fully clockwise).
 - Use an isolation transformer if available, otherwise connect a .1 mfd. condenser in series with low side of signal generator and connect to chassis.
 - Connect output meter across speaker voice coil.
 - Use lowest output setting of signal generator capable of producing adequate output meter indication and proceed in the following sequence.
 - Repeat adjustments to insure good results.
- Caution: Do not connect a ground wire directly to chassis.

Step	Dummy Antenna in Series with Signal Generator	Connection of Signal Generator (High Side)	Signal Generator Frequency	Receiver Gang Setting	Trimmer Description	Trimmer Designation	Type of Adjustment
1	250 mmfd. condenser	Antenna stator of tuning condenser	455 KC	Gang fully open	2nd IF 1st IF	*A, B *C, D	Maximum output
2	250 mmfd. condenser	Antenna stator of tuning condenser	1620 KC	Gang fully open	Oscillator	E	Maximum output

Mount and set dial pointer to horizontal position with tuning condenser tuned to 1400 KC generator signal; see illustration below.

3	Loop of several turns of wire, or place generator lead close to receiver loop for adequate signal pickup.	No actual connection (signal by radiation)	1400 KC	Tune in generator signal	Antenna	F	Maximum output
---	---	--	---------	--------------------------	---------	---	----------------

*Adjustments A and C made from the underside of the chassis. If IF transformers have hollow core slugs, these adjustments may all be made from the top of the chassis, if you use alignment tool #98A30-7 obtainable from your Admiral distributor. The bottom IF slug adjustment may be reached through the hollow core in the upper slug.

MODELS 5L21, 5L22,
5L23, Ch. 5L2

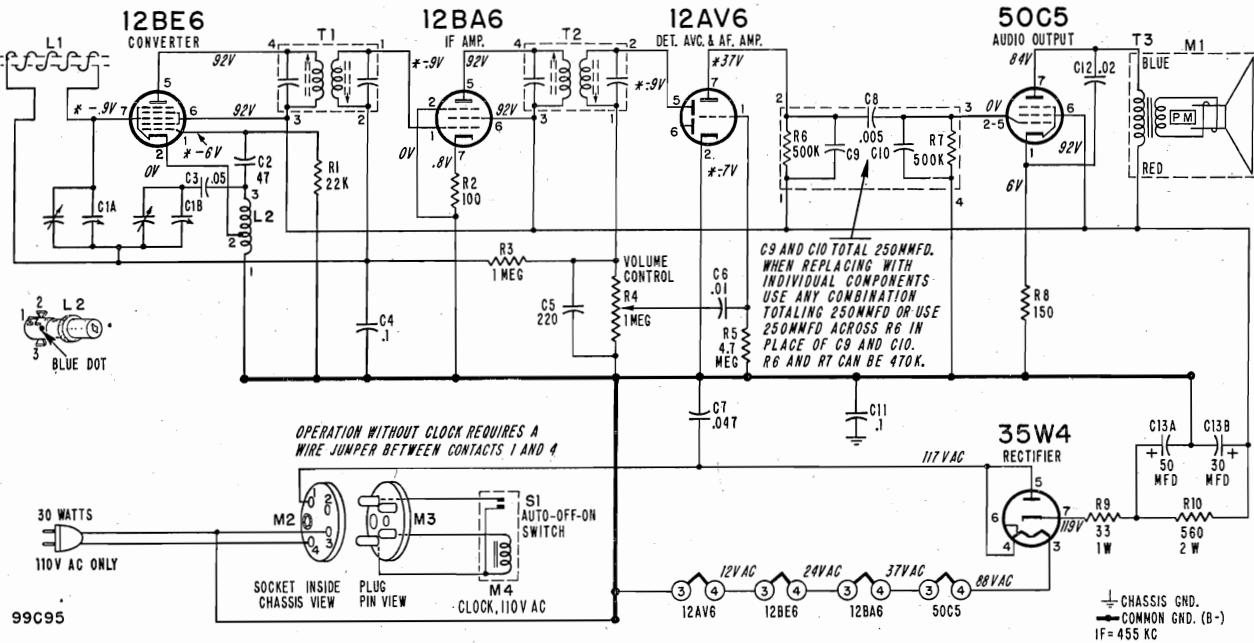

*These readings will be either lower or practically zero if taken with a 1000 ohm-per-volt meter.

VOLTAGE DATA

Voltages shown on schematic diagram

- All readings made between tube socket terminals and B minus (negative lead of electrolytic condenser C13).
- Measured on 117 Volt 60 Cycle AC line.
- Volume control minimum; dial turned to low frequency end.
- Voltages measured with Vacuum Tube Voltmeter.

RESISTORS			COIL, TRANSFORMERS, ETC.			CABINET PARTS		
Symbol	Description	Part No.	Symbol	Description	Part No.	Description	Part No.	
R1	22,000 ohms, 1/2 watt	60B 8-223	L1	Rod Antenna & Cabinet Back	69C 143-1	Bezel, Tuning Dial (Frame)	23A 107-1	
R2	100 ohms, 1/2 watt	60B 8-101	L2	Coil, Oscillator	69A 52-4	Copper Bronze finish		
R3	1 megohm, 1/2 watt	60B 8-105	T1	Transformer, 1st IF	72B 28-7	Cabinet, Plastic		
R4	1 megohm, Volume Control	75B 1-46	T2	Transformer, 2nd IF	72B 28-7	Ebony (5L21)	34D 43-1	
R5	4.7 megohms, 1/2 watt	60B 8-475	T3	Transformer, Output	98A 21	Mahogany (5L22)	34D 43-2	
R6	500,000 ohms, 1/4 watt	60B 8-151	M1	Speaker (4" PM) and Output Trans.	78B 65-2	Ivory (5L23)	34D 43-3	
R7	500,000 ohms, 1/4 watt	60B 28-3	S1	Switch, Auto-Off-On (part of M4)	91C 6-14	Grille, Speaker (plastic)	36A 22	
R8	150 ohms, 1/2 watt	60B 8-151				Knob		
R9	33 ohms, 1 watt	60B 28-3				Volume, Ebony	33D 55-28	
R10	560 ohms, 2 watt	60B 20-561				Volume, Maroon	33D 55-32	
						Volume, Ivory	33D 55-29	
						Tuning, Ebony	33D 55-24	
						Tuning, Maroon	33D 55-23	
						Tuning, Ivory	33D 55-26	
						Washer, Felt (for tuning knobs)	5A 4-18	
CONDENSERS			MISCELLANEOUS PARTS			CLOCK PARTS		
Symbol	Description	Part No.	Description	Part No.	Description	Part No.	Description	Part No.
C1A	290 mmfd. max., Ant.	68B 39	Bracket, Tuning Shaft	15A 698	M2	Socket, Clock, 4 contact	87A 6-3	
C1B	104 mmfd. max., Osc. (Dial drum spotwelded to gang)	68B 39	Carton and Fillers	44B 214	M3	Plug, Clock, 4 pin	88B 22-5	
C2	47 mmfd. ceramic	65C 6-79	Clamp, for Line Cord	11A 9-4		Shell and Insulator for plug M3	88B 22-3	
C3	.05 mfd. 400 volts, paper	64B 1-22	Clip, IF Transformer mtg.	72B 28-10	M4	Clock, Complete 60 cycle, for 5L21, 5L22, 5L23	91C 6-1	
C4	.1 mfd, 200 volts, paper	64B 1-30	Compression Ring (for pointer)	19A 31-2		Bezel, Clock (Frame)		
C5	220 mfd, ceramic	65C 6-80	Dial Cord (30" length needed)	50A 1-3		Copper Bronze finish	91C 6-10	
C6	.01 mfd, 400 volts, paper	64B 1-25	Drum, Dial Pointer	17A 27		Motor Assembly for 110 V. 60 cycles	91C 6-14	
C7	.047 mfd, 400 volts, paper	65A 13-5	Grommet, Rubber (Gang mtg.)	12A 1-19		Glass, Window	91C 6-13	
C8	.005 mfd, 450 volts	65A 13-5	Line Cord and Plug	89A 1-4		Knob, Clock Off-Auto-On	91C 6-12	
C9	See Schematic		Manual	41A 18-45		Time set, Alarm set	91C 6-11	
C10	See Schematic		Customer Instructions	41A 18-45				
C11	.1 mfd, 200 volts, paper	64B 1-30	Socket, Tube plain type	87A 24-2				
C12	.02 mfd, 400 volts, paper	64B 1-24	with grounding strap	87A 24-3				
C13A	50 mfd, 150 volts	67A 22-1	Plate, Pointer Support	15A 498				
C13B	30 mfd, 150 volts Elect.	67A 22-1	Pointer, Dial	25A 46-2				
			Sleeve, for pointer shaft	27A 124				
			Sleeve, Tuning (Brass)	27A 157				
			Speed Nut (for mtg. pointer shaft sleeve)	2B 10-28-59				
			Spring, Dial Cord Tension	19B 1-5				
			Washer, "C" (for pointer drum)	4A 4-6				

Part of couplets (part #63A5-4). Replace with exact duplicate or individual components. Note that numbers 1, 2, 3, 4, on schematic correspond to lead numbers printed on face of couplets.



RECORD CHANGER SERVICE DATA

The changer model number will be found stamped at the top rear of the changer base and also on the changer model label.

Cartridge and Needle

As shown in the illustrations, alternate cartridges may be used. Cartridges are interchangeable when complete with needle.

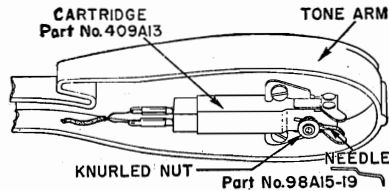
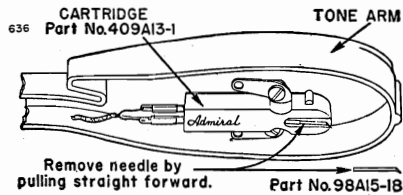

TUBE AND TRIMMER LOCATION

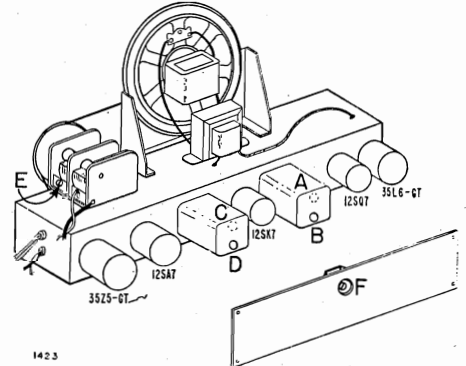

Adjustments A and C made from underside of chassis.

DIAL STRINGING AND POINTER SETTING

Dial stringing and pointer with solid lines shown with gang closed. Dashed line pointer positions (1400 KC and 900 KC) shown when tuning condenser is tuned to generator signal.

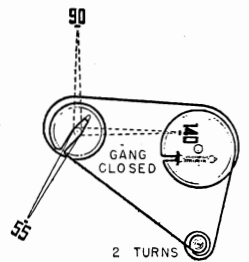

ALIGNMENT PROCEDURE

- Turn receiver volume control full on.
- Antenna must be connected and placed in the same relative position to the chassis as when in cabinet.
- Use an isolation transformer if available, otherwise connect a .1 mfd. condenser in series with low side of signal generator and connect to chassis. Caution: Do not connect a ground wire directly to chassis.
- Connect output meter across speaker voice coil.
- Use lowest output setting of signal generator capable of producing adequate output meter indication and proceed in the following sequence.
- Repeat adjustments to insure good results.

Step	Dummy Antenna in Series with Signal Generator	Connection of Signal Generator (High Side)	Signal Generator Frequency	Receiver Gang Setting	Trimmer Description	Trimmer Designation	Type of Adjustment
1	250 mmfd. condenser	Tuning condenser, antenna stator	455 KC	Gang fully open	2nd IF 1st IF	*A, B *C, D	Maximum output
2	250 mmfd. condenser	Tuning condenser, antenna stator	1620 KC	Gang fully open	Oscillator	E	Maximum output

Mount dial pointer. Set pointer to horizontal position with tuning condenser tuned to 1400 KC generator signal (see illustration below). Rotate the tuning condenser until the pointer is in a vertical position (900 KC), then slip chassis in cabinet, carefully guiding the pointer so that it locates between the dial escutcheon and the cabinet. Install antenna and chassis mounting bolts. The pointer and escutcheon may be mounted after installing the chassis in cabinet as follows: Set pointer to horizontal position with gang tuned to 1400 KC signal. Place escutcheon on cabinet. With long nose pliers slip the hairpin ends of the escutcheon mounting springs in holes of escutcheon tabs.

3	Loop of several turns of wire, or place generator lead close to receiver antenna for adequate signal pickup.	No actual connection (signal by radiation)	1400 KC	Tune in generator signal	Antenna	†F	Maximum output
---	--	--	---------	--------------------------	---------	----	----------------

*Adjustments A and C made from the underside of the chassis. If IF transformers have hollow core slugs, these adjustments may all be made from the top of chassis, if you use alignment tool #98A30-7 obtainable from your Admiral distributor. The bottom IF slug adjustment may be reached through the hollow core in the upper slug.

† Antenna Trimmer "F" should be aligned after chassis and antenna are mounted in cabinet.

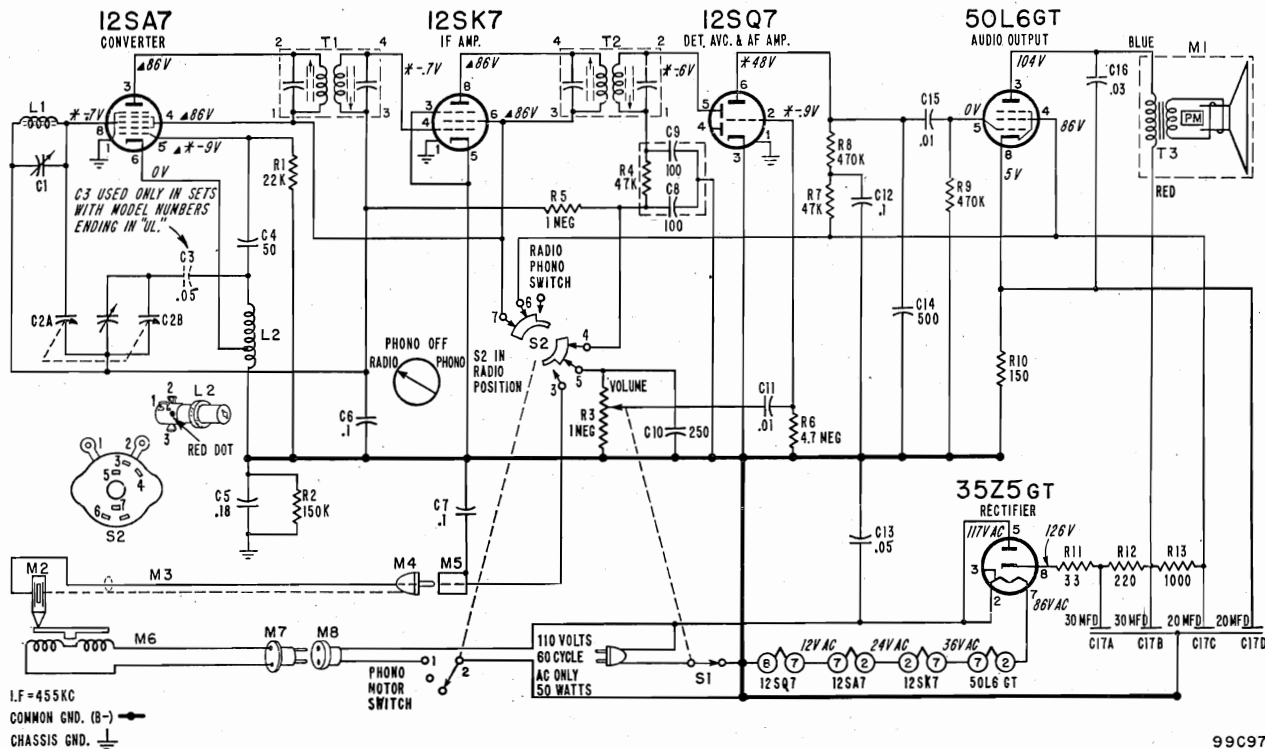

IF-455KC
COMMON GND. (B-) \rightarrow
CHASSIS GND. \perp

99C97

*These readings will be either lower or practically zero if taken with a 1000 ohm-per-volt meter.
▲ These readings will be zero on "Phono"; all other DC readings may be slightly higher.

VOLTAGE DATA

Voltages given on schematic diagram.

- All readings made between tube socket terminals and B minus (terminal of On-Off switch).
- Switch S2 in "Radio" position.
- Measured on 117 Volt 60 Cycle AC line.
- Volume control minimum; dial turned to low end.
- Voltages measured with Vacuum Tube Voltmeter.

RESISTORS

Symbol	Description	Part No.
R1	22,000 ohms, 1/2 watt	60B 8-223
R2	150,000 ohms, 1/2 watt	60B 8-154
R3	1 megohm, volume and On-Off Switch S1	75B 1-41
†R4	47,000 ohms, 1/4 watt	60B 8-473
R5	1 megohm, 1/2 watt	60B 8-105
R6	4.7 megohms, 1/2 watt	60B 8-475
R7	47,000 ohms, 1/2 watt	60B 8-473
R8	470,000 ohms, 1/2 watt	60B 8-474
R9	470,000 ohms, 1/2 watt	60B 8-474
R10	150 ohms, 1 watt	60B 14-151
R11	33 ohms, 1 watt	60B 28-3
R12	220 ohms, 1 watt	60B 28-7
R13	1,000 ohms, 1 watt	60B 28-2

CONDENSERS

Symbol	Description	Part No.
C1	Trimmer, 3 to 30 mmfd.	Part of L1
C2A	Ant. 324 mmfd. max.	Gang68B 30-1
C2B	Osc. 108 mmfd. max.	
C3	Dial drum spotwelded to gang	
C4	.05 mfd., 400 volts, paper	64B 1-22
C5	50 mmfd., Ceramic	65B 6-4
C6	.18 mfd., 200 volts, paper	64A 2-2
C7	.1 mfd., 200 volts, paper	64B 1-30
†C8	.1 mfd., 200 volts, paper	64B 1-30
†C9	100 mmfd., Ceramic	65B 6-5
C10	250 mmfd., ceramic	65B 6-5
C11	.01 mfd., 400 volts, paper	64B 1-25
C12	.1 mfd., 200 volts, paper	64B 1-30
C13	.05 mfd., 400 volts, paper	64B 1-22
C14	500 mmfd., Ceramic	65B 6-6
C15	.01 mfd., 400 volts, paper	64B 1-25
C16	.03 mfd., 400 volts, paper	64B 1-23
C17A	30 mfd., 150 volts	Elect. ...67A 14-1
C17B	30 mfd., 150 volts	
C17C	20 mfd., 150 volts	
C17D	20 mfd., 25 volts	

COILS, TRANSFORMERS, ETC.

Symbol	Description	Part No.
L1	Rod Antenna (includes board and C1)	69B 144

Symbol	Description	Part No.
L2	Coil, Oscillator	69A 52
T1	Transformer, 1st IF	72B 50
T2	Transformer, 2nd IF	72B 51
T3	Transformer, Output	79A 11-3
M1	Speaker, (5" pm)	79B 39-3
M2	Socket, Phono input	88A 1
M3	Socket & Leads, Motor	89A 6-3
S1	Switch, On-Off	Part of R3
S2	Switch, Radio-Phono	77A 28-1
	Switch, Phono Motor	Part of S2
†	Diode Filter	63A 3-1

MISCELLANEOUS

Description	Part No.
Carton and Fillers	44B 145
Clip, Electrolytic Mounting	18A 10-6
Speed Nut (esc. mtg.)	2B 10-35-68
Dial Cord	50A 1-3
Drum, Pointer	17A 27
Gasket, Sponge Rubber (mounts on Speaker)	12B 43
Grommet, Rubber (gang mtg.)	12A 1-2
Insulator, Phono Receptacle	32A 46
Manual	41A 18-46
Customer Instruction	S327
Service, for RC550 Changer	S327
Plate, Pointer Support	15A 498
Pointer, Dial	25A 35-1
Shaft, Pointer	28A 42
Sleeve, Pointer Shaft	27A 124
Sleeve, Tuning (Brass)	27A 123
Spacer, "T" (gang condenser mtg.)	29A 2-1-71
Spring, Dial Cord Tension	19B 1-5
Washer, "C" (for pointer drum)	4A 4-6
Washer, Spring	4A 6-10-0

CABINET PARTS

Description	Part No.
Cabinet, Plastic	
Bottom, less lid (Ebony 5M21)	34D 28-3
Bottom, less lid (Mahogany 5M22)	34D 28-5
Lid only (Ebony 5M21)	34D 28-11
Lid only (Mahogany 5M22)	34D 28-12

Description	Part No.
Clamp, Cable	11A 2-2
Escutcheon, Dial	
Copper Painted, for 5M22	23C 51-1
Ebony Painted, for 5M21	23C 51-3
Escutcheon Ring (Gold trim)	23A 53
Hinge Stud	37A 8-1
Hinge Screw (6/32x1/4 BH MS)	365-250-C2-58
Hinge Stud	27A 17-1
Knobs, Radio, for Ebony 5M21	
"Tuning" (outer knob)	33C 55-11
"Radio-Phono" (inner knob)	33C 55-12
"Off-On Volume"	33C 55-30
Knobs, Radio, for Mahogany 5M22	
"Tuning" (outer knob)	33C 55-7
"Radio-Phono" (inner knob)	33C 55-8
"Off-On Volume"	33C 55-31
Rubber Bumper	
for cabinet bottom	12A 3-4
for cabinet top	12A 9-8
Spring, Escutcheon Retaining	19A 60
Stay Arm and Plate	37A 9-1
Washer, Felt (for tuning knobs)	5A 4-11

PHONOGRAPH PARTS

Symbol	Description	Part No.
M2	Cartridge Pickup (includes needle)	409A 13
M3	Cable, Shielded Pickup (includes plug)	413A 11-1
M4	Plug, Pickup Cable	88A 2-3
M6	Motor, Phono (3 speed)	407B 19
M7	Plug, Motor (Male)	88A 8-1
	Adapter, 45 RPM (envelope of 12)	48A 8-1
	Button, Snap-in Plug	13A 2-8-57
	Centerpost, Record	G400B 505-1
	Idler Wheel (Includes tire)	G400A 279
	Needle, Pickup	
	for 409A13 cartridge	98A 15-19
	for 409A13-1 cartridge	98A 15-18
	Needle Retaining Nut (for 409A13 cartridge)	98A 54-2
	Service Manual, RC550 Changer	S327
	Screw and Washer, Changer Mounting (10-32x1/4 RH MS)	AA210
	Spring, Changer Float	19A 10-3

† Part of Diode Filter 63A3-1. This unit consisting of C8, C9 and R4 may be replaced with individual components.

SPECIFICATIONS

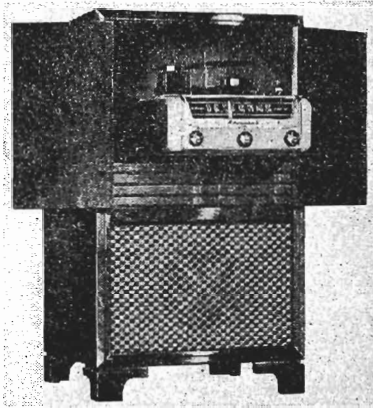

Models 6N25, 6N26, 6N27.

Models 6N25, 6N26 and 6N27 are combination sets consisting of a 5R2 radio chassis, a 1PA4 power supply and a RC550 record changer. The 5R2 radio chassis is a 5 tube (AM only) superhetro-dyne receiver used with a 1PA4 (one tube) power supply. Operate the radio and record changer only from a 60 cycle AC (alternating current) power line of from 110 to 120 volts. Power, 80 watts.

RECORD CHANGER SERVICE DATA

The changer model number will be found stamped at the top rear of the changer base and also on the changer model label.

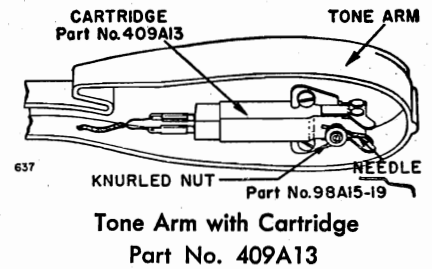

Cartridge and Needle

As shown in the illustrations at right, alternate cartridges may be used. Cartridges are interchangeable when complete with needle.

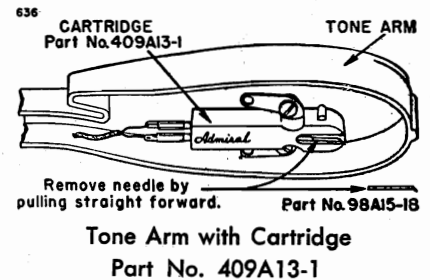

TUBE AND TRIMMER LOCATION

3006

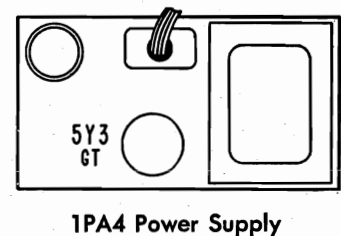
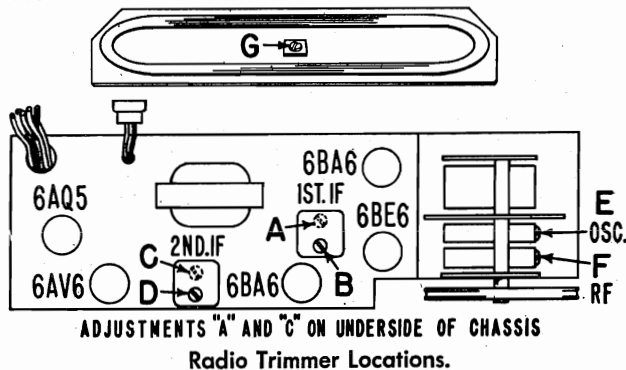

MODELS 6N25, 6N26,
6N27, Ch. 5R2

ALIGNMENT PROCEDURE

IMPORTANT: For IF alignment, it will be necessary to disassemble the radio chassis from the escutcheon and housing and also remove the chassis cover and dial scale assembly. The antenna, RF and oscillator trimmers are accessible from top of chassis; disassembly of chassis cover and dial scale will generally not be required.

- Connect output meter across speaker voice coil.
- Turn receiver Volume control fully on; Tone control fully clockwise.
- Radio-Phono switch in "Radio" position.
- Antenna must be connected and placed in the same relative position to the chassis as when in the cabinet.
- Use lowest output setting of signal generator that gives a satisfactory reading on meter.
- Use a non-metallic alignment tool for IF adjustments.
- Repeat adjustments to insure good results.

Step	Dummy Antenna in Series with Signal Generator	Connection of Signal Generator (High Side)	Signal Generator Frequency	Receiver Gang Setting	Trimmer Description	Trimmer Designation	Type of Adjustment
1	.1 mfd. condenser	Pin 7 of 6BE6 tube	455 KC	Gang fully open	2nd IF 1st IF	*A, B *C, D	Maximum Output
2	.1 mfd. condenser	Tuning condenser, antenna stator	1620 KC	"	Oscillator	E	"
3	Loop of several turns of wire, or place generator lead close to receiver loop for adequate signal.	No actual connection (signal by radiation)	1400 KC	Tune in generator signal	RF	F	"
4	"	"	"	"	Antenna	G	"

*Adjustments "A" and "C" are made from underside of chassis.

REMOVING RADIO CHASSIS FROM HOUSING

To remove the radio chassis from the front housing proceed as follows:

1. Position the gang condenser drum as shown below.
2. Unhook spring at "A".
3. Keeping tension on dial cord, hook spring to edge of cut out at "B".
4. Remove six screws "C" and hex nuts "D" and "E".
5. Remove front housing from chassis.
6. Reassemble in reverse order. See illustration below for pointer setting.

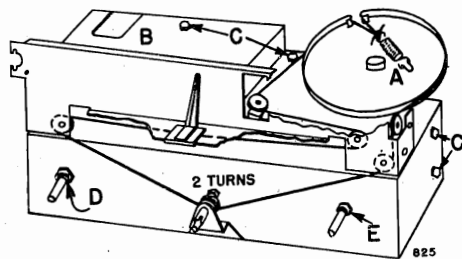

Radio Chassis With Front Housing Removed.
Dial Stringing Also Shown.

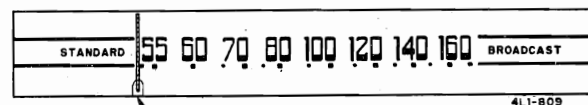

Dial Scale and Pointer Setting.

MODELS 6N25, 6N26,
6N27, Ch. 5R2

RESISTORS

Symbol	Description	Part No.
R1	150 ohms, 1/2 watt	60B 8-151
R2	39,000 ohms, 1 watt	60B 14-393
R3	10,000 ohms, 1 watt	60B 14-103
R4	22,000 ohms, 1/2 watt	60B 8-223
R5	150 ohms, 1/2 watt	60B 8-151
R6	27,000 ohms, 1 watt	60B 14-273
†R7	47,000 ohms, 1/2 watt	
R8	1 megohm, 1/2 watt	60B 8-105
R9	4.7 megohms, 1/2 watt	60B 8-475
R10A	1 megohm, Volume } pot.	75B 11-11
R10B	2 megohms, Tone }	
(R10 includes switch S2)		
R11	82,000 ohms, 1/2 watt	60B 8-823
R12	470,000 ohms, 1/2 watt	60B 8-474
R13	47,000 ohms, 1/2 watt	60B 8-473
R14	470,000 ohms, 1/2 watt	60B 8-474
R15	270 ohms, 2 watts	60B 20-271
R16	310 ohms, 5 watts }	
R17	310 ohms, 5 watts }	61A 5-10

CONDENSERS

Symbol	Description	Part No.
C1	5 mmfd, mica	65B 1-62
C2	2 to 20 mmfd, trimmer	66B 8-5
C3A	420 mmfd, max. } Gang	68B 46-2
C3B	193.8 mmfd, max. }	
C3C	90 mmfd, max. }	
(Note: Dial drum spot-welded to gang)		
C4	.1 mfd, 400 volts, paper	64B 5-20
C5	50 mmfd, ceramic	65B 6-4
C6	.1 mfd, 400 volts, paper	64B 5-20
C7	.005 mfd, min, ceramic	65A 10-1
†C8	100 mmfd, ceramic	
†C9	100 mmfd, ceramic	
C10	.1 mfd, 200 volts, paper	64B 5-30
C11	.01 mfd, min, ceramic	65A 10-3
C12	100 mmfd, min, ceramic	65B 6-3
C13	.005 mfd, min, ceramic	65A 10-1
C14	.002 mfd, min, ceramic	65A 10-7
C15	.01 mfd, min, ceramic	65A 10-3
C16	.1 mfd, 400 volts, paper	64B 5-20
C17	.1 mfd, 400 volts, paper	64B 5-20
C18	.002 mfd, 600 volts, paper	64B 5-14
C19	50 mfd, 25 volts, elect.	67A 4-10
C20A	20 mfd, 350 volts }	67C 15-17
C20B	20 mfd, 350 volts }	
C20C	60 mfd, 400 volts }	

COILS, TRANSFORMERS, ETC.

Symbol	Description	Part No.
L1	Antenna Loop	69C116-2
L2	Coil, RF	69A 115-2
L3	Coil, Oscillator	69A 52-5
T1	Transformer, 1st IF	72B 28-7
T2	Transformer, 2nd IF	72B 28-7
T3	Transformer, Output	79A 22
T4	Transformer, Power	80B 22
M10	Speaker (8" PM)	78B 49-3
S1	Switch, Radio-Phono	77A 28-2
S2	Switch, On-Off	Part of R10
	Diode Filter	63A3-1

MISCELLANEOUS PARTS

Symbol	Description	Part No.
M5	Socket, Phono Input	88A1
M7	Socket, Phono Motor	89A 6-11

†Part of diode filter (part #63A3-1). Replace with exact duplicate or individual components.

M8	Plug, Cable Connector	88A 20-1
	Cover and Insulator (for plug 88A20-1)	88A 20-12
	Cable (9 wire), including Plug and cover	AB225
M9	Socket, Cable	88A 20-2
	Clip, IF Transformer Mtg.	72B 28-10
	Cover Assembly, Chassis	A1880
	Dial Back and Bracket Assembly	A1881
	Dial Cord (50" length needed)	50A 1-3
	Dial Scale	22B 23-1
	Escutcheon, Radio	23D 63-3
	Grommet, Gang Mounting	12A 1-2
	Pilot Light, #47	81A 1-8
	Pointer, Metal Dial	25A 37
	Shaft, Tuning	28A 48-1
	Snap Button (for mtg. dial scale)	13A 1-1-71
	Socket, Pilot Light	82A 6-3
	Socket, Tube (7 pin miniature)	87A 3-7
	Spacer Sleeve (for mounting gang)	29A 2-1-71
	Speed Nut (for mounting radio escutcheon)	2B 12-4-68
	Spring, Dial Cord Tension	19B 1-3
	Spring, Hairpin (for tuning shaft)	19A 2-5

CABINET PARTS

Description	Part No.
Back, Cabinet	43C 169-2
*Cabinet, Wood	
Walnut (6N25)	35E 189-1
Mahogany (6N26)	35E 189-2
Blond (6N27)	35E 189-3
Cartons and Fillers	44B 202
‡Door Catch and Strike Plate. See ‡ note below	
Door Handle	37A 64-1
Doors, Matched Pair	
for Walnut (6N25)	35E 189-50
for Mahogany (6N26)	35E 189-51
for Blond (6N27)	35E 189-52
Grille Cloth	
for Walnut (6N25) and Mah. (6N26)	36C 3-60
for Blond (6N27)	36C 3-61
‡Hinge, Knife Door. See ‡ note below	
Knob, 'Radio-Phono', Tuning	33D 55-1
Knob, 'Tone'	33D 55-4
Knob, 'Volume'	33D 55-5
Bracket, Slide-out Drawer Stop	15A 782
Pull, Slide-out Drawer	37A 66-1
Slide, Drawer	37A 32-9

PHONOGRAPH PARTS

Symbol	Description	Part No.
M1	Motor, Phono (3 speed)	407B 19
M2	Cartridge Pickup (includes needle)	409A 13 or 409A 13-1
M3	Cable, Shielded Pickup (includes plug)	413A 11-2
M4	Plug, Pickup Cable	88A 2-3
M6	Plug, Motor (Male)	88A 8-1
	Adapter, 45 RPM (envelope of 12)	43A 8-1
	Button, Snap-in Plug	13A 2-8-57
	Belt, Rubber Drive	406A 20
	Centerpost, Record	G400B 505-1
	Idler Wheel (includes tire)	G400A 59
	Needle, Pickup	
	for 409A13 cartridge	98A 15-19
	for 409A13-1 cartridge	98A 15-18
	Needle Retaining Nut (for 409A13 cartridge)	98A 54-2
	Screw and Washer, Changer Mounting (10-32x1 1/4 RH MS)	AA210
	Spring, Changer Float	405A 139

*To insure proper matching and fit, also specify cabinet manufacturer's code letters (usually burned or stamped on back rail of cabinet). Wood parts are supplied only if old part cannot be repaired; when ordering, describe condition of old part in detail.

‡Order these parts using the part number given in Cabinet Hinge Ordering Data, Form No. S379. Otherwise, return old part, or send an outline tracing (exact size) of part and specify finish (brass, bronze, etc.).

MODELS 5S21, 5S22, 5S23, Ch. 5S2

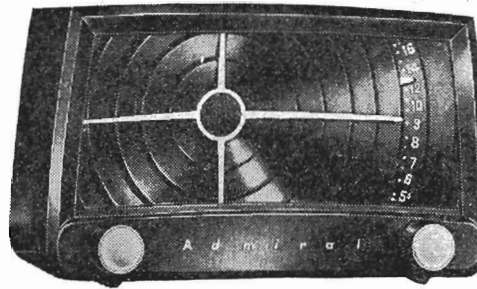

Model 5S21 Ebony, 5S22 Mahogany, 5S23 Ivory.
Operating Voltage: 117 volts, 60 cycle AC or DC. Power: 30 watts.

ALIGNMENT PROCEDURE

- Connect output meter across speaker voice coil.
 - Turn receiver volume control full on.
 - Use an isolation transformer if available, otherwise connect a .1 mfd. condenser in series with low side of signal generator and connect to chassis.
 - Use lowest output setting of signal generator capable of producing adequate output meter indication and then proceed as outlined in chart below.
 - Repeat adjustments to insure good results.
- Caution: Do not connect a ground wire directly to chassis.

Step	Dummy Antenna in Series with Signal Generator	Connection of Signal Generator (High Side)	Signal Generator Frequency	Receiver Gang Setting	Trimmer Description	Trimmer Designation	Type of Adjustment
1	250 mmfd. condenser	Antenna stator of tuning condenser	455 KC	Gang fully open	2nd IF 1st IF	*A, B *C, D	Maximum Output
2	250 mmfd. condenser	Antenna stator of tuning condenser	1620 KC	Gang fully open	Oscillator (on gang)	E	Maximum Output
3	Loop of several turns of wire or place generator lead close to receiver loop for adequate signal pickup.	No actual connection (signal by radiation)	1400 KC	Tune in generator signal	Antenna (on gang)	F	Maximum Output
4	Set dial pointer slide as shown in Dial Cord Stringing Diagram. Also see instructions below on "Setting Pointer Slide" and on "Removing Or Installing Chassis In Cabinet."						

*Adjustments A and C made from the underside of the chassis. If IF transformers have hollow core slugs, these adjustments may all be made from the top of chassis, if you use alignment tool #98A30-7 obtainable from your Admiral distributor. The bottom IF slug adjustment may be reached through the hollow core in the upper slug.

TUBE AND TRIMMER LOCATION

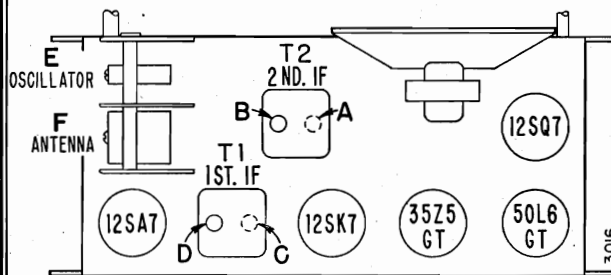

Adjustments A and C are made from underside of chassis.

REMOVING OR INSTALLING CHASSIS IN CABINET

Fully close the gang condenser before removing or installing the chassis in the cabinet. When installing, carefully slide the chassis in the cabinet, so that the tab on the pointer slide fits into the elongated hole at the center of the dial pointer. See the "Pointer Setting and Dial Stringing" diagram at the right. Parts which are shown in dotted lines are not assembled to the chassis. These parts are mounted on the inside of the cabinet.

POINTER SETTING AND DIAL CORD STRINGING

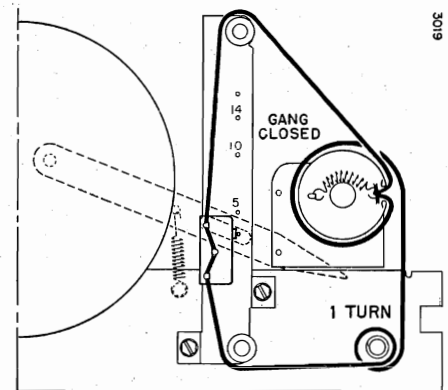

SETTING POINTER SLIDE

With the gang condenser fully closed, line up the center of the pointer slide with the bottom hole in the pointer slide bracket as shown in the figure above.

S464

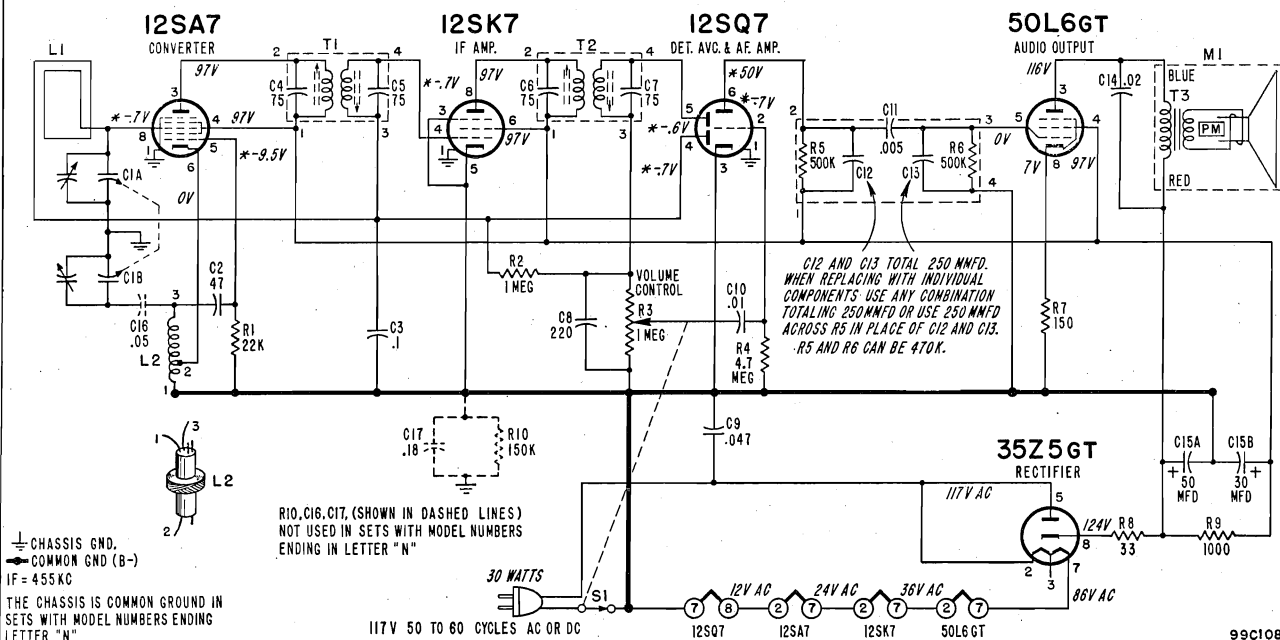

*These voltage readings will be either lower or practically zero if taken with a 1000 ohm-per-volt meter.

VOLTAGE DATA

Voltages shown on schematic diagram.

- All readings made between tube socket terminals and B minus (terminal of On-Off switch).
- Dial turned to low frequency end; volume control at minimum.
- Measured on 117 Volts AC line.
- Voltages measured with Vacuum Tube Voltmeter.

RESISTORS

Symbol	Description	Part No.
R1	22,000 ohms, 1/2 watt	60B 8-223
R2	1 megohm, 1/2 watt	60B 8-105
R3	1 megohm, Volume Control and On-Off switch S1	75B 1-25
R4	4.7 megohms, 1/2 watt	60B 8-475
†R5	500,000 ohms, 1/2 watt	
†R6	500,000 ohms, 1/2 watt	
R7	150 ohms, 1/2 watt	60B 8-151
R8	33 ohms, 1 watt	60B 28-3
R9	1,000 ohms, 1 watt	60B 28-2
R10	150,000 ohms, 1/2 watt	60B 8-154

R10 not used in sets with model numbers ending in "N".

CONDENSERS

C1a	Ant., 420 mmfd., max.	Gang 68B 48 (Dial drum spot welded to gang)
C1b	Osc., 108 mmfd., max.	
C2	47 mmfd., ceramic	65C 6-79
C3	.1 mfd., 200 volts, paper	64B 1-30
C4	75 mmfd., 3%	Part of T1
C5	75 mmfd., 3%	Part of T1
C6	75 mmfd., 3%	Part of T2
C7	75 mmfd., 3%	Part of T2

†Part of couplate (part 63A 5-4). Replace with exact duplicate or individual components. Note that numbers 1, 2, 3, 4, on schematic correspond to couplate lead numbers printed on face of couplate 63A 5-4.

Symbol	Description	Part No.
C8	220 mmfd., ceramic	65C 6-80
C9	.047 mfd., 400 volts, paper	65A13-5
C10	.01 mfd., 400 volts, paper	64B 1-25
†C11	.005 mfd., 400 volts	
†C12	{ See note on schematic.	
†C13		
C14	.02 mfd., 400 volts, paper	64B 1-24
C15a	50 mfd., 150 volts	elect 67A 10
C15b	30 mfd., 150 volts	
C16	.05 mfd., 400 volts, paper	64B 1-22
C17	.18 mfd., 200 volts, paper	64A 2-2

(C16 and C17 not used in sets with model numbers ending in "N".)

COILS, TRANSFORMERS, ETC.

L1	Antenna, Loop (mounted on cardboard back)	69C 154
L2	Coil, Oscillator	69A 20-2
T1	Transformer, 1st I.F.	72B 50
T2	Transformer, 2nd I.F.	72B 51
T3	Transformer, Output	98A 4
	Speaker (5" PM) and Output Transformer	78B 26-1
S1	Switch, On-Off Couplate	Part of R3 63A 5-4

(Includes R5, R6, C11, C12, C13)

MISCELLANEOUS

Description	Part No.
Bracket, Pointer Slide	15A 801
Cabinet	
Ebony (5S21)	34D 26-12
Mahogany (5S22)	34D 26-13
Ivory (5S23)	34D 26-14
Carton and Fillers	44B 236
Clip, Electrolytic Mounting	18A 10-6
Dial Cord (27" length needed)	50A 1-3
Dial Background	22A 30
Knob, Tuning	
Ebony (5S21)	33A 81-1
Ivory (5S23)	33A 81-2
Mahogany (5S22)	33A 81-3
Pointer, Dial	25A 52
Shaft, Tuning	28A 26-6
Slide, Pointer	15A 800
Snap Button (mtg pointer to cabinet)	13A 1-2-59
Snap Button (mtg. dial background)	13A 1-3-59
Socket, Tube	87A 10-2
Spacer, Tuning Shaft	29A 2-1-71
Speed Nut (for tuning shaft spacer)	2B 10-19-2
Spring, Dial Cord Tension	19C 1-2
Spring, Pointer Tension	19C 1-20
Washer, "C" (tuning shaft)	4A 4-6-0
Washer, Spring (tuning shaft)	4A 6-3-0

SPECIFICATIONS

Circuit: Superheterodyne using 4 miniature tubes and a selenium rectifier.

Frequency Range: Standard broadcast band, 535 to 1620 KC.

Intermediate Frequency: 455 KC.

Power Supply: Power line of 117 volts, 50 to 60 cycles AC or DC. Batteries using one 67½ volt "B" battery and one 7½ volt "A" battery.

Power Consumption: 20 watt on operation from power line.

Antenna: Built-in Ferro-Scope (iron core) antenna.

Speaker: 3½" PM, with a 1 oz. Alnico V magnet. Voice coil impedance, 3.2 ohms.

REPLACING BATTERIES

Replacement batteries of the following types may be used in this set:

"A" Battery (7½ Volts): General 31, Eveready 717, Burgess C5, Ray-O-Vac 751C or equivalent.

"B" Battery (67½ Volts): General 108, Eveready 467, Burgess XX45, Ray-O-Vac 4367 or equivalent.

The "A" and "B" batteries have been designed for equal life. Under normal operating conditions, battery life should be approximately 40 operating hours. The "A" battery may give satisfactory performance with voltage as low as 5.5 volts. The "B" battery may give satisfactory performance with voltage as low as 49.5 volts. Replace the batteries when the reception is weak and the battery voltage has dropped below values given above.

To install replacement batteries, slide the cover latch and open the hinged bottom cover. Then remove the wing nut which holds the battery support bracket in place.

Disconnect the battery connectors from the old worn out batteries. Batteries can easily be removed from the set by grasping them with long nose pliers or if necessary, removing the cabinet bottom. Install the new batteries so that the battery connectors are farthest away from the ends of the battery bracket. Batteries may become shorted if the bracket touches the connectors.

Note: It is important that the run-down batteries be removed from the set IMMEDIATELY because the chemical action inside of the cells will cause some batteries to leak when they are worn out. The acid which leaks from a run-down battery may damage parts of the set or the cabinet because of its corrosive action.

REPLACING TUBES

Tubes can most conveniently be removed or replaced by first removing the batteries and cabinet bottom. A miniature tube puller or extractor will be of help in facilitating tube replacement.

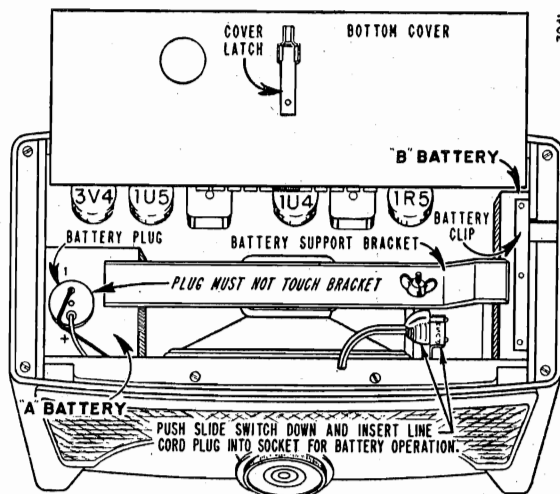

Tube and Battery Location

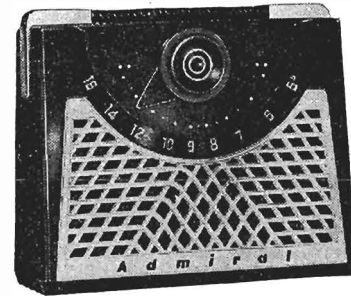

Models 4V12 Mahogany, 4V18 Green and 4V19 Ebony.

REMOVING AND INSTALLING CHASSIS IN CABINET

Removal of the chassis from the cabinet is not required when replacing tubes or batteries. It will, however, be necessary to remove the chassis for making alignment or for taking voltage readings. For taking voltage readings, it will also be necessary to remove the metal cover enclosing the underside of the chassis.

To remove the chassis from the cabinet, proceed as follows:

- (a) Remove the tuning knob, pointer hub and cabinet bottom (base). The speaker grille may be removed by pulling it down and away from the cabinet.
- (b) Remove the 2 chassis mounting screws located at the top inside of the cabinet, just below the handle brackets.
- (c) Carefully slide the chassis out of the cabinet, being careful not to damage the built-in iron core antenna or the speaker.

Install the chassis in the cabinet in the reverse order. A screwdriver with a magnetic blade or a screw holding type screwdriver will be of help in inserting the chassis mounting screws when installing the chassis in the cabinet.

STRINGING THE VOLUME CONTROL DRIVE CORD

The illustration below shows the volume control drive cord

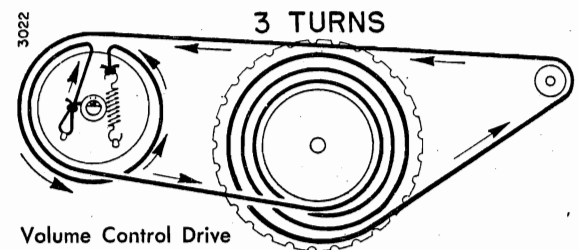

Volume Control Drive Cord Stringing VOLUME OFF

stringing used in 4V1 radio chassis. The arrows along the drive cord show the direction in which the volume control drive cord is strung.

Before stringing the drive cord, rotate the volume control fully counterclockwise until the on-off switch snaps in the off position. Place the volume knob over the gang condenser tuning shaft. To prevent the volume knob from slipping off during drive cord stringing, mount the dial pointer hub to the gang condenser tuning shaft. To prevent slipping of the volume control drive, it is important to maintain tension on the drive cord tension spring.

TRIMMER LOCATION

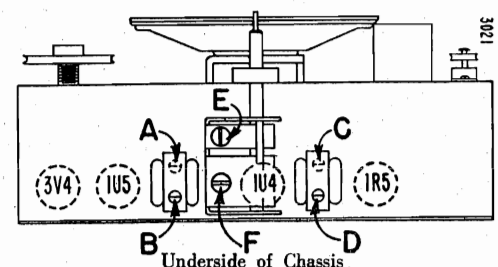

Adjustments A and C are made from other side of chassis.

MODELS 4V12, 4V18, 4V19, Ch. 4V1

ALIGNMENT PROCEDURE

- Use battery power for alignment if fresh batteries are available. If using AC power, an isolation transformer should be used if available. If an isolation transformer is not used, connect a .1 mfd. condenser in series with the signal generator low side to B minus (pin 7 of 1U5 tube.)
- Batteries should be held in place on the chassis during alignment.
- The metal chassis cover need not be removed during alignment.
- Set volume control full on.
- Connect output meter across speaker voice coil.
- Use lowest setting of signal generator capable of producing adequate output meter indication.
- Use a non-metallic alignment tool for IF transformers.
- Repeat adjustments to insure good results.

Step	Dummy Antenna in Series with Signal Generator	Connection of Signal Generator (High Side)	Signal Generator Frequency	Receiver Gang Setting	Trimmer Description	Trimmer Designation	Type of Adjustment
1	.001 mfd. when using AC. .1 mfd. when using Battery	Antenna stator of tuning condenser	455 KC	Gang fully open	2nd IF 1st IF	*A, B *C, D	Maximum output
2	.001 mfd. when using AC. .1 mfd. when using Battery	Antenna stator of tuning condenser	1620 KC	Gang fully open	Oscillator (on gang)	E	Maximum output
Install the metal chassis cover if removed during IF Alignment.							
3	Loop of several turns of wire, or place generator lead close to receiver for adequate signal pickup.	No actual connection (signal by radiation)	1400 KC	Tune in generator signal	Antenna (on gang)	F	Maximum output

*Adjustments A and C are made from other side of chassis.

RESISTORS

Symbol	Description	Part No.
R1	2.2 megohms, 1/2 watt	60B 8-225
R2	270 ohms, 1/2 watt	60B 8-271
R3	100,000 ohms, 1/2 watt	60B 8-104
R4	18,000 ohms, 1/2 watt	60B 8-183
R5	3.3 megohms, 1/2 watt	60B 8-335
R6	10 megohms, 1/2 watt	60B 8-106
R7	390 ohms, 1/2 watt	60B 8-391
R8	1 megohm, Vol. Control. (R8 includes Switch S1)	75B 1-43
R9	120 ohms, 1/2 watt	60B 8-121
†R10	10 megohms, 1/2 watt	
†R11	4.7 megohms, 1/2 watt	
†R12	1 megohm, 1/2 watt	
†R13	3.3 megohms, 1/2 watt	
R14	2,200 ohms, 1/2 watt	60B 8-222
R15	47 ohms, 1 watt	60B 14-470
R16	2,700 ohms, 1 watt	60B 14-272
R17A	1380 ohms } 5 watt, tapped	
R17B	1380 ohms } Candohm	61A 5-7

CONDENSERS

Symbol	Description	Part No.
C1A	272 mmfd, max. Ant. } gang	68B 41
C1B	107 mmfd, max. Osc. }	
C2	250 mmfd, ceramic	65C 6-5
C3	.25 mfd, 200 volts, paper	64B 1-28
C4	100 mmfd, ceramic	65C 6-3
C5	.005 mfd, ceramic	65C 10-5
C6	.01 mfd., 400 volts, paper	64B 1-25
C7	.001 mfd, min, ceramic	65C 6-41
C8	100 mfd, 25 volts, elect.	67A 4-6
†C9	100 mmfd, ceramic	
†C10	.001 mfd, min, ceramic	
†C11	.01 mfd, min, ceramic	
†C12	100 mmfd, ceramic	
†C13	.005 mfd, ceramic	
C14	.001 mfd, min, ceramic	65C 6-41
C15	.1 mfd, 200 volts, paper	64B 1-30
C16	.047 mfd, 400 volts, paper	65A 13-5
C17A	20 mfd, 150 volts }	
C17B	30 mfd, 150 volts }	elect. 67C 7-41
C17C	20 mfd, 150 volts }	

COILS, TRANSFORMERS, ETC.

Symbol	Description	Part No.
L1	Antenna, Rod	69C 120-1
L2	Coil, Oscillator	69A 39-6
T1	Transformer, 1st IF	72B 28-1
T2	Transformer, 2nd IF	72B 28-62
T3	Transformer, Output	98A 21
M1	Speaker (3 1/2" PM) and Output Trans.	78B 58-1
M2	Rectifier, Selenium	93A 1-6
S1	Switch, On-Off	Part of R8
S2	Switch, Power Change	77A 19-1
	Couplate (includes R10, R11, R12, R13, C9, C10, C11, C12, C13)	63B 6-6

MISCELLANEOUS PARTS

Description	Part No.
Baffle, Speaker	43A 174
Bracket	
battery support	15A 603
volume pulley and bracket ass'y	A3316
shield for gang	15A 618
cover for AC switch	15A 595
Carton and Fillers	44B 165
Clip, IF Transformer Mounting	72B 28-10
Clip "B" Battery Connector	90A 5-3
Cover, Metal for chassis	14C 70
Drum, Vol. Control	17A 30
Insulator, Fibre (for mtg. rectifier)	32A 137
Customer Instructions	41B 20-3
Dial Cord (30" length needed)	50A 1-3
Nut, Wing (=6/32 for battery support bracket)	2A 5-4-71
Plate, Electrolytic Mounting	67A 2-1
Plug, "A" Battery Connector	88A 4-6
Hub, Brass	
mounts on volume control shaft	27A 153
Screw, Set	
for volume control drum (=6-32x3/16)	1A 43-8
Socket, Tube	87A 3-4
Washer, Spring (5/16" ODx3/16" ID)	4A 6-13

CABINET PARTS

Symbol	Description	Part No.
Bottom, Cabinet (Base)		
Mahogany for 4V12		
complete with metal door		A3721
plastic frame only		34D 35-4

Description Part No.

Bottom, Cabinet (Base) contd.	
Green for 4V18	
complete with metal door	A3493
plastic frame only	34D 35-6
Ebony for 4V19	
complete with metal door	A3270
plastic frame only	34D 35-2
Bracket, Handle Support (metal ends)	20B 14
Cabinet (less bottom)	
Mahogany for 4V12	34D 49-2
Green for 4V18	34D 49-3
Ebony for 4V19	34D 49-1
Dial Pointer and Hub Assembly (includes compression ring)	
Mahogany for 4V12	A3711
Green for 4V18	A3712
Red for 4V19	A3713
Escutcheon Overlay, Plastic	23C 112-1
Grille Cloth and Support Assembly	
Bracket	
Mahogany for 4V12 and 4V19	AA227-2
Green for 4V18	AA227-3
Handle, Carrying (plastic covering only)	
Mahogany for 4V12	33A 58-2
Green for 4V18	33A 58-3
Red for 4V19	33A 58-6
Hinge, Bottom Cover	37A 33
Knob, Volume	
Mahogany for 4V12	33C 67-3
Green for 4V18	33C 67-5
Red for 4V19	33C 67-6
Knob, Tuning (includes compression ring)	
Mahogany for 4V12	A3707
Green for 4V18	A3708
Red for 4V19	A3709
Ring, Compression (for tuning knob)	19A 31-7
Ring, Compression (for pointer hub)	19A 31-2
Rivet, Shoulder	
with 7/64 shoulder	6A 4-12-71
with 3/32 shoulder	6A 4-7-71
Rubber Strap, for carrying handle	
upper, with 13/32" holes	12A 38
lower, with 1/4" holes	12A 38-1
Screw	
=4x5/8 self tapping; for mtg. plastic base to cabinet	1A 69-6-71
=8-32x7/16; for mtg. handle and chassis	280-437-C2-71
Slide Arm (for bottom door)	15A 291
Spring, Support (for carrying handle)	18A 42
Washer, Felt (for volume knob)	5A 4-8

†Part of couplate (part #63B 6-6). Replace with extra duplicate or individual components. Note that numbers 1, 2, 3, 4, 5, 6, 7, 8, 9 on schematic correspond to lead numbers printed on face of couplate.

MODELS 4V12,
4V18, 4V19,
Ch. 4V1

VOLTAGE DATA

Voltages shown on schematic diagram.

- All voltages taken between tube socket terminals and B minus (pin 7 of 1U5 tube).
- Dial turned to low frequency end; volume control at minimum.
- Voltages measured with Vacuum Tube Voltmeter from 117 Volts AC line.

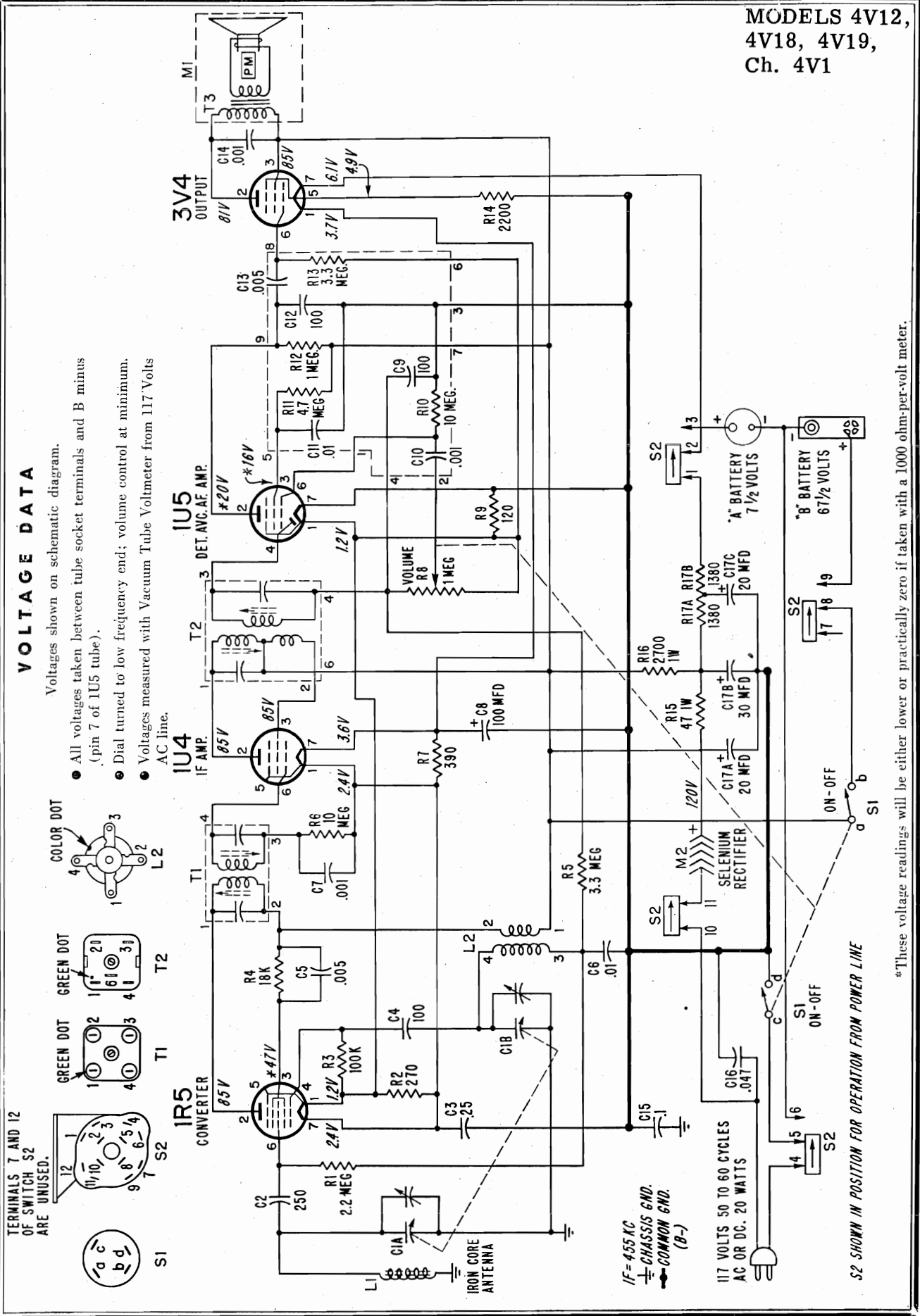

TERMINALS 7 AND 12 OF SWITCH S2 ARE UNUSED.

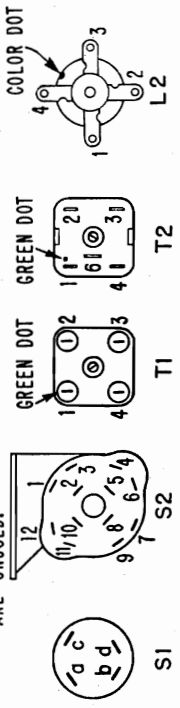

IF = 455 KC
 CHASSIS GND.
 COMMON GND. (B-)

117 VOLTS 50 TO 60 CYCLES AC OR DC. 20 WATTS

S2 SHOWN IN POSITION FOR OPERATION FROM POWER LINE

*These voltage readings will be either lower or practically zero if taken with a 1000 ohm-per-volt meter.

MODELS 5Y22, 5Y22A, Ch. 5Y2

ALIGNMENT PROCEDURE

- Turn receiver volume control full on.
- Antenna must be connected and placed in the same relative position to the chassis as when in cabinet.
- Use an isolation transformer if available, otherwise connect a .1 mfd. condenser in series with low side of signal generator and connect to chassis. Caution: Do not connect a ground wire directly to chassis.
- Connect output meter across speaker voice coil.
- Use lowest output setting of signal generator capable of producing adequate output meter indication and proceed in the following sequence.
- Repeat adjustments to insure good results.

Step	Dummy Antenna in Series with Signal Generator	Connection of Signal Generator (High Side)	Signal Generator Frequency	Receiver Gang Setting	Trimmer Description	Trimmer Designation	Type of Adjustment
1	250 mmfd. condenser	Tuning condenser, antenna stator	455 KC	Gang fully open	2nd IF 1st IF	*A, B *C, D	Maximum output
2	250 mmfd. condenser	Tuning condenser, antenna stator	1620 KC	Gang fully open	Oscillator	E	Maximum output

Mount dial pointer. Set pointer to horizontal position with tuning condenser tuned to 1400 KC generator signal (see Dial Stringing and Pointer Setting diagram below). Rotate the tuning condenser until the pointer is in a vertical position (900 KC), then slip chassis in cabinet, carefully guiding the pointer so that it locates between the dial escutcheon and the cabinet. Install antenna and chassis mounting bolts.

3	Loop of several turns of wire, or place generator leads close to receiver antenna for adequate signal pickup.	No actual connection (signal by radiation)	1400 KC	Tune in generator signal	Antenna	†F	Maximum output
---	---	--	---------	--------------------------	---------	----	----------------

*Adjustments A and C made from the underside of the chassis. If IF transformers have hollow core slugs, these adjustments may all be made from the top of chassis, if you use alignment tool #98A30-7 obtainable from your Admiral distributor. The bottom IF slug adjustment may be reached through the hollow core in the upper slug.
 † Antenna Trimmer "F" should be aligned after chassis and antenna are mounted in cabinet.

TUBE AND TRIMMER LOCATION

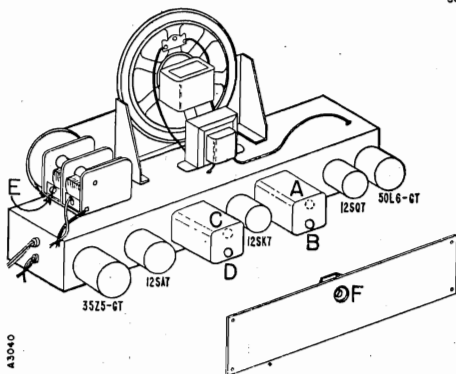

Adjustments A and C made from underside of chassis.

DIAL STRINGING AND POINTER SETTING

Solid lines show dial stringing and pointer position with gang closed. Dashed lines show pointer positions (1400 KC and 900 KC) when gang condenser is tuned to a generator signal.

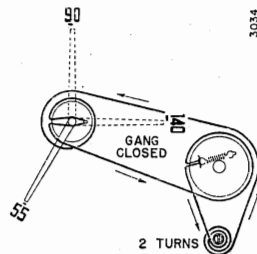

RECORD CHANGER SERVICE DATA

The changer model number will be found stamped at the top rear of the changer base and also on the changer model label.



Models 5Y22 and 5Y22A

DIFFERENCES IN MODELS
 Models 5Y22 and 5Y22A are the same with exception of the Radio-Phono switch and the record changer. Model 5Y22 has a 3 position Radio-Phono switch and uses the RC550 record changer. Model 5Y22A has a 2 position Radio-Phono switch and uses the RC600 record changer. See circuit notes on schematic.

Cartridge and Needle

As shown in the illustrations, alternate cartridges may be used. Cartridges are interchangeable when complete with needle.

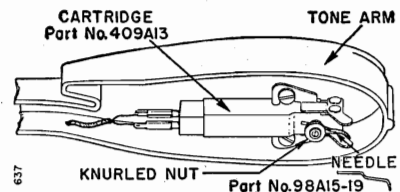
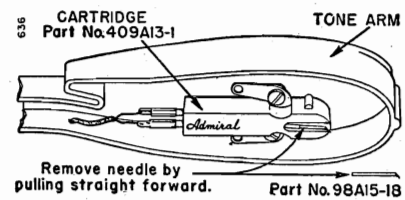

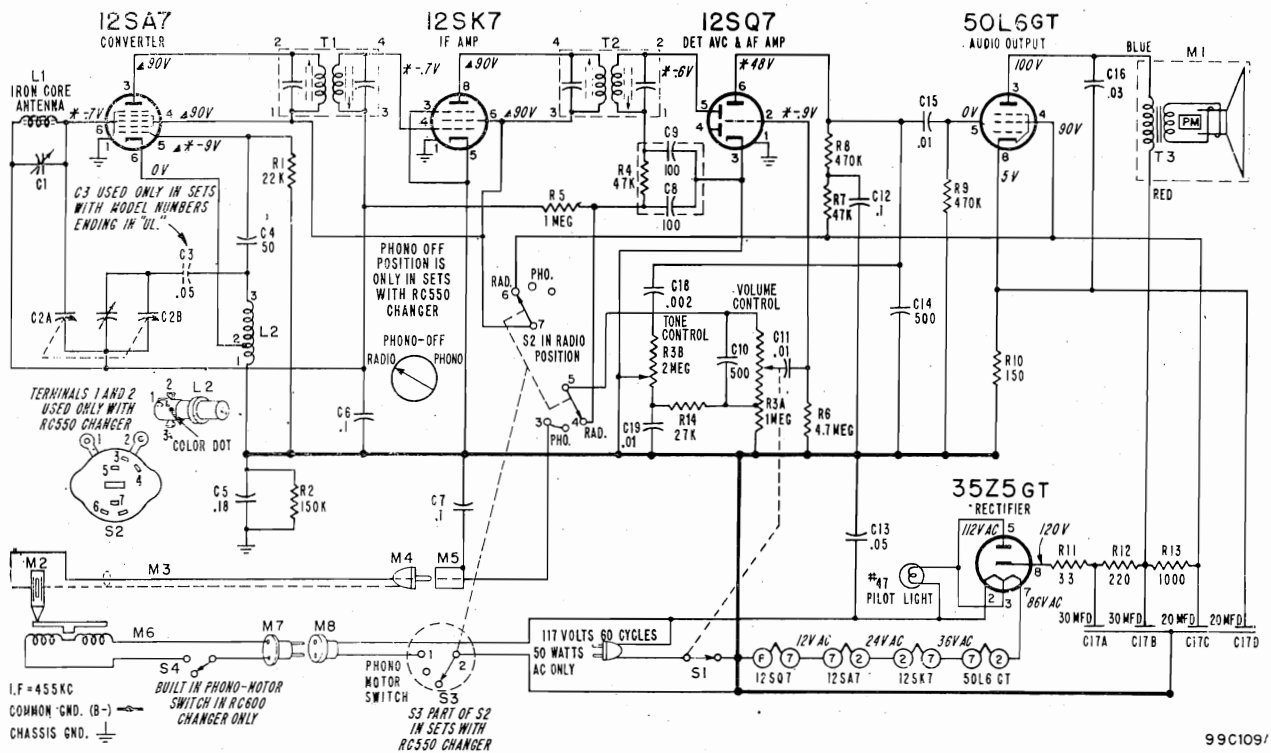

* These readings will be lower if taken with a 1000 ohm-per-volt meter.
 ▲ These readings will be zero on "Phono"; all other DC readings may be slightly higher.

OPERATING VOLTAGE
 117 volts, 60 cycles AC only; 50 watts

VOLTAGE DATA

Voltagess given on schematic diagram.

- All readings made between tube socket terminals and B minus (terminal of On-Off switch).
- Radio-Phono switch S2 in "Radio" position.
- Measured on 117 Volt, 60 Cycle AC line.
- Volume control minimum; dial turned to low end.
- Voltages measured with Vacuum Tube Voltmeter.

RESISTORS		
Symbol	Description	Part No.
R1	22,000 ohms, 1/2 watt	60B 8-223
R2	150,000 ohms, 1/2 watt	60B 8-154
R3A	1 megohm, Volume	75B 11-8
R3B	2 megohms, Tone	
(R3 includes switch S1)		
R4	47,000 ohms, 1/2 watt	60B 8-105
R5	1 megohm, 1/2 watt	60B 8-475
R6	4.7 megohms, 1/2 watt	60B 8-473
R7	47,000 ohms, 1/2 watt	60B 8-474
R8	470,000 ohms, 1/2 watt	60B 8-474
R9	470,000 ohms, 1/2 watt	60B 8-474
R10	150 ohms, 1 watt	60B 14-151
R11	33 ohms, 1 watt	60B 28-3
R12	220 ohms, 1 watt	60B 28-7
R13	1,000 ohms, 1 watt	60B 28-2
R14	27,000 ohms, 1/2 watt	60B 8-273

CONDENSERS		
Symbol	Description	Part No.
C1	Trimmer, 3 to 30 mmd.	66A 33
C2A	Ant. 324 mmd, max.	68B 30-1
C2B	Osc. 103 mmd, max. } gang	
(Dial drum spotwelded to gang)		
C3	.05 mfd, 400 volts, paper	64B 1-7
C4	50 mmd, ceramic	65C 6-4
C5	.18 mfd, 200 volts, paper	64A 2-2
C6	.1 mfd, 200 volts, paper	64B 1-5
C7	.1 mfd, 200 volts, paper	64B 1-5
C8	100 mmd, ceramic	65C 6-6
C9	100 mmd, ceramic	
C10	500 mmd, ceramic	65C 6-6
C11	.01 mfd, 400 volts, paper	64B 1-10
C12	.1 mfd, 200 volts, paper	64B 1-5
C13	.05 mfd, 400 volts, paper	64B 1-7
C14	500 mmd, ceramic	65C 6-6
C15	.01 mfd, 400 volts, paper	64B 1-10
C16	.03 mfd, 400 volts, paper	64B 1-8
C17A	30 mfd, 150 volts	elect. 67A 14-1
C17B	30 mfd, 150 volts	
C17C	20 mfd, 150 volts	
C17D	20 mfd, 25 volts	
C18	.002 mfd, 600 volts, paper	64B 1-14
C19	.01 mfd, 400 volts, paper	64B 1-10

COILS, TRANSFORMERS, ETC.		
Symbol	Description	Part No.
L1	Rod Antenna (includes board and C1)	69B 144
L2	Coil, Oscillator	69A 52
T1	Transformer, 1st IF	72B 50

Symbol	Description	Part No.
T2	Transformer, 2nd IF	72B 51
T3	Transformer, Output	79A 11-3
M1	Speaker, (5" PM)	78B 39-3
M5	Socket, Phono Input	88A 1
M8	Socket & Leads, Motor	89A 6-3
S1	Switch, On-Off	Part of R3
S2	Switch, Radio-Phono for sets with RC550 record changer	77A 28-1
	for sets with RC600 record changer	77A 45
S3	Switch, Phono-Motor (S3 used only in sets with RC550 record changer)	Part of S2
	Diode Filter	63A 3-1

MISCELLANEOUS

Carton and Fillers	44B 213
Clip, Electrolytic Mounting	18A 10-6
Speed Nut (esc. mtg.)	2B 10-28-50
Dial Cord (40" length needed)	50A 1-3
Drum, Pointer	17A 27
Gasket, Sponge Rubber (mounts on speaker)	12B 43
Grommet, Rubber (gang mtg.)	12A 1-2
Insulator, Phono Receptacle	32A 46
Manual, Customer Instruction for RC550 record changer	41B 20-19
Manual, Service for RC550 record changer	41B 20-25
Manual, Service for RC600 record changer	S327
Pilot Light, #47	S454
Pointer, Dial	81A 1-8
Pointer, Dial	25A 35-3
Shaft, Pointer	28A 42
Shield, Pilot Light	82A 15-1
Sleeve, Pointer Shaft	27A 162-1
Sleeve, Tuning (brass)	27A 123
Socket, Pilot Light	82A 2-2
Spacer, "T" (gang condenser mtg.)	29A 2-1-71
Spring, Dial Cord Tension	19B 1-5
Washer, "C" (for pointer drum)	4A 4-6
Washer, Spring	4A 6-10-0

CABINET PARTS

Cabinet, Plastic	
Bottom, less lid	34D 28-5
Lid only	34D 28-6

Description	Part No.
Clamp, Cable	11A 2-2
Escutcheon, Dial	23C 51-2
Escutcheon Ring (gold trim)	23A 53-1
Hinge	37A 8-1
Hinge Screw (6/32x1/4 BH MS)	365-250-C2-58
Hinge Stud	27A 17-1
Jewel, Pilot Light	82A 14-1
Knobs, Radio	
"Tuning" (outer knob)	33D 55-7
"Radio-Phono" (inner knob)	33D 55-43
"Off-On Volume" (inner knob)	33D 55-47
"Tone" (outer knob)	33D 55-9
Rubber Bumper for cabinet bottom	12B 3-4
for cabinet top	12A 9-8
Speed Nut, Escutcheon Retaining	2B 10-35-68
Spring, Escutcheon Retaining	19A 60
Stay Arm and Plate	37A 9-1
Washer, Felt (for tuning knobs)	5A 4-18

PHONOGRAPH PARTS

M2 Cartridge Pickup (includes needle)	409A 13
M3 Cable, Shielded Pickup (includes plug)	413A 11-1
M4 Plug, Pickup Cable	88A 2-3
M6 Motor, Phono (3 speed) for RC550 record changer	407B 19
for RC600 record changer	407C 20
M7 Plug, Motor (Male)	88A 8-1
Adapter, 45 RPM (envelope of 12) for RC550 record changer	48A 8-1
for RC600 record changer	48A 8-2
Button, Snap-in Plug	13A 2-8-57
Centerpost Assembly for RC550 record changer	G400B 505-1
for RC600 record changer	G400B 601
Idler Wheel (includes tire) for RC550 record changer	G400A 59
for RC600 record changer	G400A 279
Manual, Service for RC550 record changer	S327
for RC600 record changer	S454
Needle, Pickup for 409A13 cartridge	98A 15-19
for 409A13-1 cartridge	98A 15-18
Needle Retaining Nut (for 409A13 cartridge)	98A 54-2
Screw and Washer, Changer Mounting (10-32x1 1/4 RH MS)	AA210
Spring, Changer Float	19A 10-3

§Part of Diode Filter 33A 3-1. This unit consisting of C8, C9 and R4 may be replaced with individual components.

MODELS 5A32/12, /15, /16, 5A33/12, /15, /16, Ch. 5A3

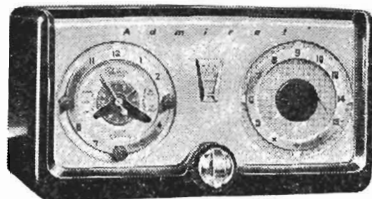

Model 5A32 Mahogany, 5A33 Ivory
 Operating Voltage: 117 volt AC only.
 Power: 30 watts.

ALIGNMENT PROCEDURE

- Turn receiver volume control full on (fully clockwise).
- Use an isolation transformer if available, otherwise connect a .1 mfd. condenser in series with low side of signal generator and connect to chassis.
 Caution: Do not connect a ground wire directly to chassis.
- Connect output meter across speaker voice coil.
- Use lowest output setting of signal generator capable of producing adequate output meter indication and proceed in the following sequence.
- Repeat adjustments to insure good results.

Step	Dummy Antenna in Series with Signal Generator	Connection of Signal Generator (High Side)	Signal Generator Frequency	Receiver Gang Setting	Trimmer Description	Trimmer Designation	Type of Adjustment
1	250 mmfd. condenser	Antenna stator of tuning condenser	455 KC	Gang fully open	2nd IF 1st IF	*A, B *C, D	Maximum output
2	250 mmfd. condenser	Antenna stator of tuning condenser	1620 KC	Gang fully open	Oscillator	E	Maximum output

Mount and set dial pointer to horizontal position with tuning condenser tuned to 1400 KC generator signal; see illustration below.

3	Loop of several turns of wire, or place generator lead close to receiver loop for adequate signal pickup.	No actual connection (signal by radiation)	1400 KC	Tune in generator signal	Antenna	F	Maximum output
---	---	--	---------	--------------------------	---------	---	----------------

*Adjustments A and C made from the underside of the chassis. If IF transformers have hollow core slugs, these adjustments may all be made from the top of the chassis, if you use alignment tool #98A30-7 obtainable from your Admiral distributor. The bottom IF slug adjustment may be reached through the hollow core in the upper slug.

TUBE AND TRIMMER LOCATION

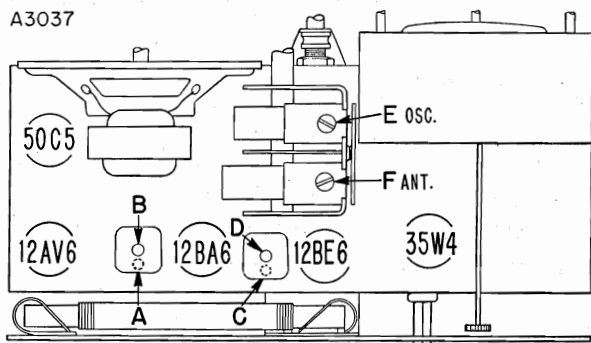

Adjustments A and C made from underside of chassis.

DIAL STRINGING AND POINTER SETTING

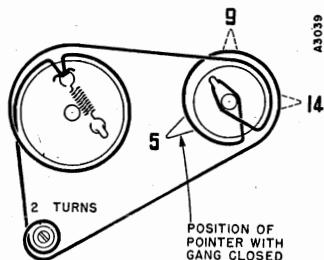

Dial stringing and pointer with solid lines shown with gang closed. Dashed line pointer positions (1400 KC and 900 KC) shown when tuning condenser is tuned to generator signal.

OPERATING RADIO MANUALLY

To operate the radio manually, the "Auto-Off-On" switch must be in the "On" position or the radio will not operate.

The radio on-off switch will turn the radio on or off, but will have no control over the appliance or the clock.

TO REMOVE CLOCK FROM CABINET

To remove the clock, proceed as follows:

1. Remove the radio chassis from the cabinet.
2. Remove the three hexagonal nuts and lock washers which mount the clock movement to the metal cover.
3. Carefully remove the clock movement from the cover. Do not unsolder leads unless complete removal of the clock is required. The metal cover mounting the clock to the chassis may be removed if more space is required for servicing the clock.

TO REMOVE FIELD AND COIL ASSEMBLY OR TO REMOVE ROTOR

The field and coil assembly and the rotor can be easily removed after the two screws which mount the nameplate are removed.

Note that when the rotor is replaced, the gear on the rotor must drop into the hole in the center of the gear plate and mesh with the clock gear.

MODELS 5A32/12, /15, /16, 5A33/12, /15, /16, Ch. 5A3

C9 AND C10 TOTAL 250 MMFD. WHEN REPLACING WITH INDIVIDUAL COMPONENTS, USE ANY COMBINATION TOTALING 250 MMFD OR USE 250 MMFD ACROSS R6 IN PLACE OF C9 AND C10. R6 AND R7 CAN BE 470K.

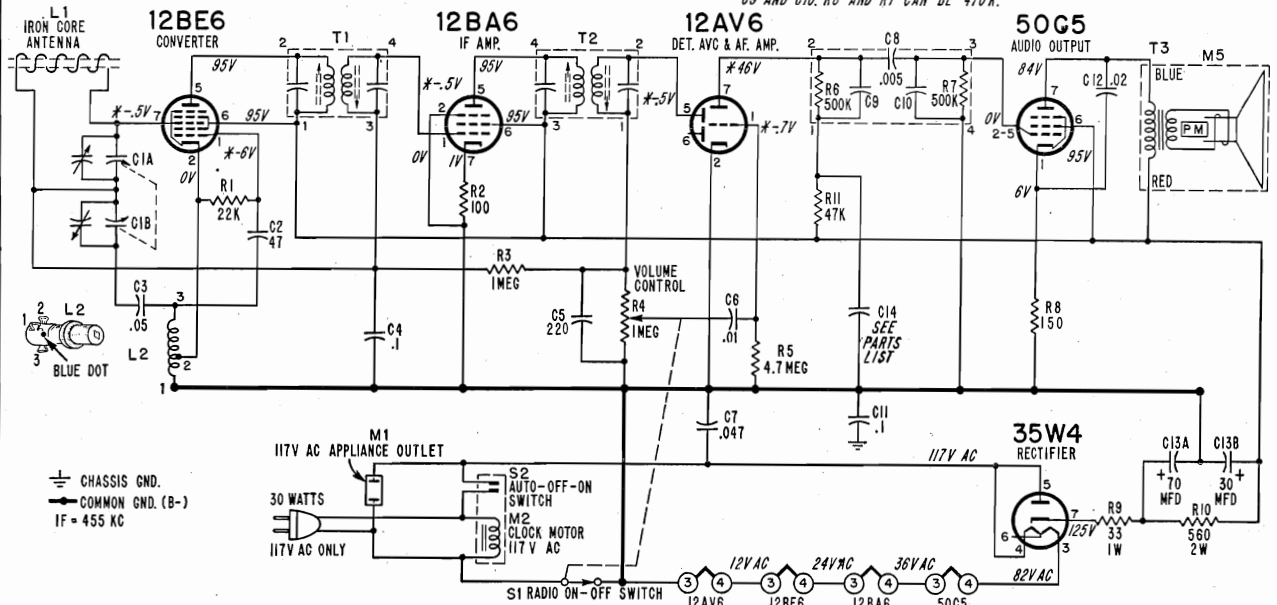

*These voltage readings will be either lower or practically zero if taken with a 1000 ohm-per-volt meter.

VOLTAGE DATA

Voltages shown on schematic diagram.

- All readings made between tube socket terminals and B minus (terminal of On-Off switch).
- Measured on 117 Volt AC line.
- Volume control minimum; dial turned to low frequency end.
- Voltages measured with Vacuum Tube Voltmeter.

RESISTORS

Symbol	Description	Part No.
R1	22,000 ohms, 1/2 watt	60B 8-223
R2	100 ohms, 1/2 watt	60B 8-101
R3	1 megohm, 1/2 watt	60B 8-105
R4	1 megohm, Volume control. 75B 1-41 (R4 includes switch S1)	
R5	4.7 megohms, 1/2 watt	60B 8-475
R6	500,000 ohms, 1/4 watt	
R7	500,000 ohms, 1/4 watt	
R8	150 ohms, 1/2 watt	60B 8-151
R9	33 ohms, 1 watt	60B 28-3
R10	560 ohms, 2 watts	60B 20-561
R11	47,000 ohms, 1/2 watt	60B 8-473

CONDENSERS

Symbol	Description	Part No.
C1A	290 mmfd, max., Ant. } (Dial drum spotwelded to gang)	68B 39
C1B	104 mmfd, max., Osc. } (Dial drum spotwelded to gang)	
C2	47 mmfd, ceramic	65C 6-79
C3	.05 mfd, 400 volts, paper	64B 1-22
C4	.1 mfd, 200 volts, paper	64B 1-30
C5	220 mmfd, ceramic	65C 6-80
C6	.01 mfd, 400 volts, paper	64B 1-25
C7	.047 mfd, 400 volts, paper	65A 13-5
C8	.005 mfd, 400 volts	
C9	{ See note	
C10	{ on schematic	
C11	.1 mfd, 200 volts, paper	64B 1-30
C12	.02 mfd, 400 volts, paper	64B 1-24
C13A	70 mfd, 150 volts } (in later sets)	67A 17
C13B	30 mfd, 150 volts } (in later sets)	
C14	.25 mfd, 200 volts, paper (in later sets) 4 mfd, 150 volts, elect. (in early sets)	64B 1-28 67A 4-2

Part of couplate (part No. 63A 5-4). Replace with exact duplicate or individual components. Note that numbers 1, 2, 3, 4, on schematic correspond to lead numbers printed on face of couplate.

COIL, TRANSFORMERS, ETC.

Symbol	Description	Part No.
L1	Rod Antenna and Cabinet Back	69C 156
L2	Coil, Oscillator	69A 52-4
T1	Transformer, 1st IF	72B 28-7
T2	Transformer, 2nd IF	72B 28-7
T3	Transformer, Output	98A 21
M1	Outlet, Appliance	87A 21-1
M5	Speaker (4" PM) and Output Transformer	78B 72-1
S1	Switch, Radio On-Off	(part of M4)
S2	Switch Auto-On-Off	91C 4-14
Couplate	(Includes R6, R7, C8, C9, C10)	63A5-4

MISCELLANEOUS PARTS

Baffle Ring, Speaker	12B 49
Bracket, Dial Pointer Support	15A 498
Bracket, Tuning Shaft	15A 698
Carton and Fillers	44B 228
Clip, IF Transformer Mounting	72B 28-10
Compression Ring (for pointer)	19A 31-10
Dial Cord (20" length needed)	50A 1-3
Drum, Dial Pointer	17A 27
Grommet, Rubber (gang mtg.)	12B 1-19
Line Cord and Plug	89A 34-1
Manual, Customer Instruction	41B 20-11
Shaft, Dial Pointer	28A 42-2
Sleeve (for pointer shaft)	27A 124
Sleeve, Tuning (brass)	27A 157
Socket, Tube	
plain	87A 24-2
with grounding strap	87A 24-3
Speaker Gasket	12B 49
Spacer, Metal "T" (for mtg. gang)	29A 2-1-71
Speed Nut (mtg. pointer shaft sleeve)	2B 10-28-59
Spring, Dial Cord Tension	19C 1-5
Washer, "C" (for pointer drum)	4A 4-5
Washer, Spring (for tuning shaft)	4A 6-10-0

CABINET PARTS

Description	Part No.
Cabinet, Plastic Mahogany	34D 56-2
Ivory	34D 56-3
Escutcheon and Speaker Grille Assembly	AA230
Knob	
Off-Volume, Mahogany	33D 55-3
Off-Volume, Ivory	33D 55-27
Tuning, Mahogany	33D 55-3
Tuning, Ivory	33D 55-28
Pointer and Hub Assembly (includes compression ring)	
Mahogany	A3732
Ivory	A3733
Washer, Felt (for dial pointer)	5A 4-3
Washer, Felt (for tuning knobs)	5A 4-18

CLOCK PARTS

M2 Clock, Complete	
for 117 volts, 60 cycles	91C 7-1
for 117 volts, 50 cycles	91C 7-2
for 117 volts, 25 cycles	91C 7-3
Back Cover (fibre)	32A 151
Bumper, Sleep Switch (rubber)	12B 3-6
Cover (metal)	15B 838
Field and Coil Assembly	
for 117 volts, 60 cycles	91C 4-15
for 117 volts, 50 cycles	91C 4-18
for 117 volts, 25 cycles	91C 4-19
Knob, Clock	
Mahogany	91C 7-11
Ivory	91C 7-12
Rotor	
for 117 volts, 60 cycles	91C 4-16
for 117 volts, 50 cycles	91C 4-18
for 117 volts, 25 cycles	91C 4-20
Window (plastic)	24B 11

MODELS 5Z22,
5Z23, Ch. 5Z2

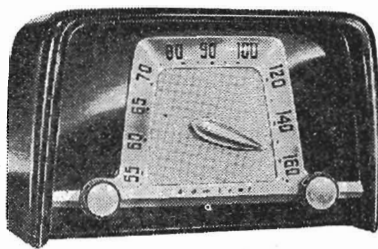

Model 5Z22 Mahogany and 5Z23 Ivory
Operating Voltage: 117 volts, 50 to 60
cycles AC or DC.
Power: 30 watts.

ALIGNMENT PROCEDURE

- Connect output meter across speaker voice coil.
 - Turn receiver volume control full on.
 - Use an isolation transformer if available, otherwise connect a .1 mfd. condenser in series with low side of signal generator and connect to chassis.
 - Use lowest output setting of signal generator capable of producing adequate output meter indication and then proceed as outlined in chart below.
 - Repeat adjustments to insure good results.
- Caution: Do not connect a ground wire directly to chassis.

Step	Dummy Antenna in Series with Signal Generator	Connection of Signal Generator (High Side)	Signal Generator Frequency	Receiver Gang Setting	Trimmer Description	Trimmer Designation	Type of Adjustment
1	250 mmfd. condenser	Antenna stator of tuning condenser	455 KC	Gang fully open	2nd IF 1st IF	*A, B *C, D	Maximum Output
2	250 mmfd. condenser	Antenna stator of tuning condenser	1620 KC	Gang fully open	Oscillator (on gang)	E	Maximum Output
3	Loop of several turns of wire or place generator lead close to receiver loop for adequate signal pickup.	No actual connection (signal by radiation)	1400 KC	Tune in generator signal	Antenna (on gang)	F	Maximum Output
4	Mount and set dial pointer as shown in "Pointer Setting and Dial Cord Stringing" diagram.						

*Adjustments A and C made from the underside of the chassis. If IF transformers have hollow core slugs, these adjustments may all be made from the top of chassis, if you use alignment tool #98A30-7 obtainable from your Admiral distributor. The bottom IF slug adjustment may be reached through the hollow core in the upper slug.

TUBE AND TRIMMER LOCATION

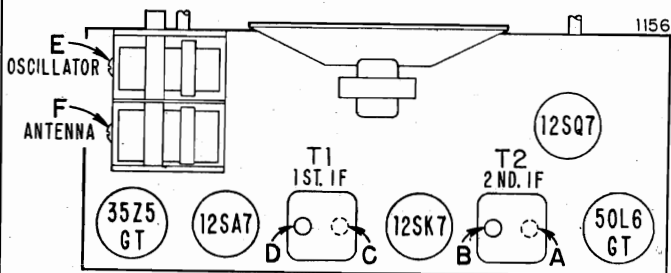

Adjustments A and C made from underside of chassis.

POINTER SETTING AND DIAL CORD STRINGING

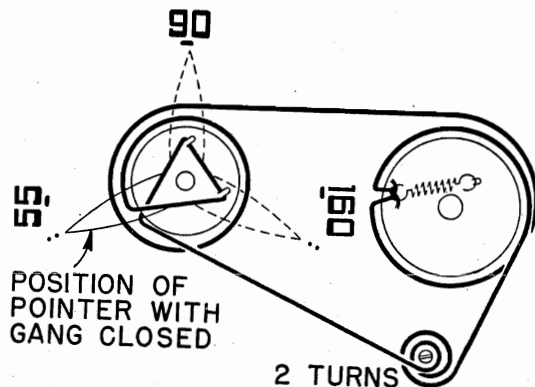

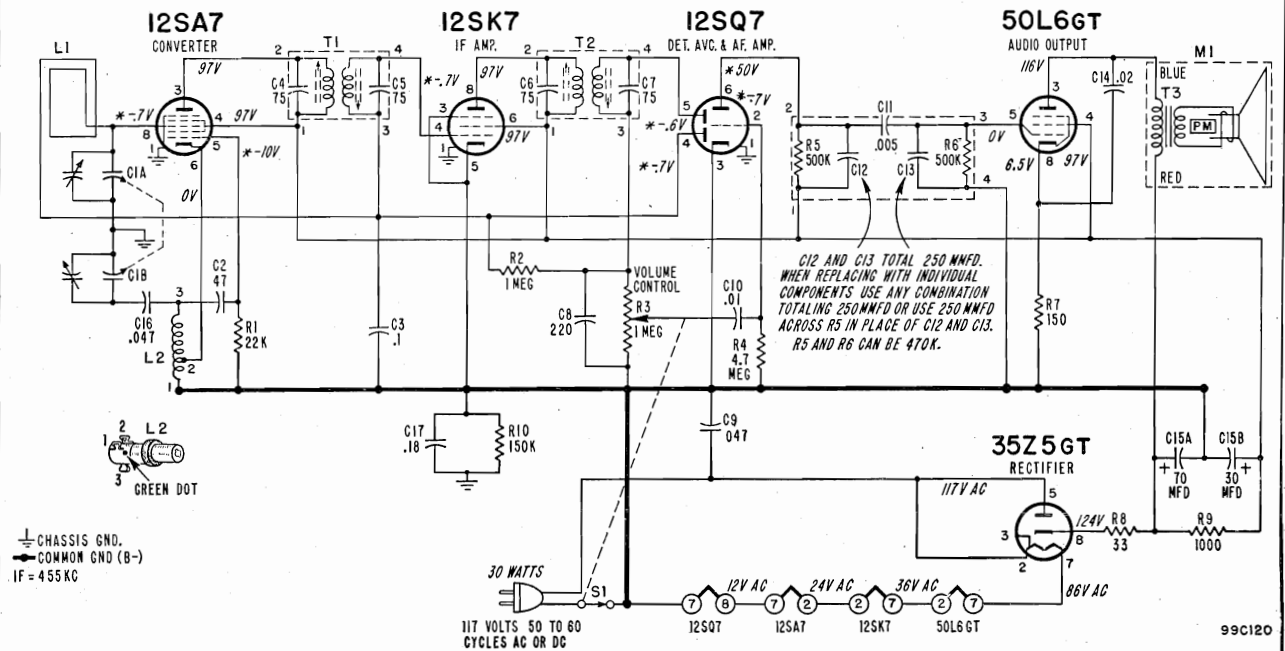

⊥ CHASSIS GND.
 ← COMMON GND (B-)
 IF = 455 KC

99C120

*These voltage readings will be either lower or practically zero if taken with a 1000 ohm-per-volt meter.

VOLTAGE DATA

Voltages shown on schematic diagram.

- All readings made between tube socket terminals and B minus (terminal of On-Off switch).
- Dial turned to low frequency end; volume control at minimum.
- Measured on 117 Volts AC line.
- Voltages measured with Vacuum Tube Voltmeter.

RESISTORS			COILS, TRANSFORMERS, ETC.			MISCELLANEOUS	
Symbol	Description	Part No.	Symbol	Description	Part No.	Description	Part No.
R1	22,000 ohms, 1/2 watt	60B 8-223	L1	Antenna, Loop (mounted on cardboard back)	69C 142-2	Cabinet	
R2	1 megohm, 1/2 watt	60B 8-105	L2	Coil, Oscillator	69A 52-3	Ebony (5Z21)	34D 54-1
R3	1 megohm, Volume control (R3 includes switch S1)	75B 1-40	T1	Transformer, 1st I.F.	72B 50	Mahogany (5Z22)	34D 54-2
R4	4.7 megohms, 1/2 watt	60B 8-475	T2	Transformer, 2nd I.F.	72B 51	Ivory (5Z23)	34D 54-3
R5	500,000 ohms, 1/2 watt		T3	Transformer, Output	98A 4	Carton and Fillers	44B 191
R6	500,000 ohms, 1/2 watt		S1	Switch, On-Off (Includes R5, R6, C11, C12, C13)	63A 5-4	Clip, Elect., Mtg.	18A 10-6
R7	150 ohms, 1/2 watt	60B 8-151				Dial Cord (32" length required)	50A 1-3
R8	33 ohms, 1 watt	60B 28-3				Drum, Dial Pointer	17A 35-1
R9	1,000 ohms, 1 watt	60B 28-2				Escutcheon, Dial Scale	23C 126-1
R10	150,000 ohms, 1/2 watt	60B 8-154				Grille, Speaker (metal)	16A 34-1
						Knob, Tuning	
						Ebony (for 5Z21)	33A 64-4
						Ivory (for 5Z23)	33A 64-3
						Mahogany (for 5Z22)	33A 64-2
						Pointer, Dial	25A 45-1
						Ring, Dial Pointer Compression	19A 31-2
						Shaft, Dial Pointer	28A 42-1
						Sleeve, Tuning	28A 26-4
						Sleeve, Dial Pointer Shaft	27A 162
						Snap Button (for mtg. cabinet back)	13A 1-5
						Snap Button, (for mtg. speaker grille)	13A 1-2-71
						Socket, Tube	87A 10-2
						Speed Nut, Escutcheon Retaining	2B 10-35-68
						Speed Nut (for tuning shaft spacer)	2B10-21-59
						Spring, Dial Cord Tension	19B 1-5
						Washer, "C" (tuning shaft)	4A 4-6-0
						Washer, Felt (knob)	5A 4-4
						Washer, "C" (for pointer shaft)	4A 4-6-0

†Part of couplate (part 63A 5-4). Replace with exact duplicate or individual components. Note that numbers 1, 2, 3, 4, on schematic correspond to couplate lead numbers printed on face of couplate 63A 5-4.

MODEL 6M22, Ch. 6M2

ALIGNMENT PROCEDURE

- Turn receiver volume control full on.
- Antenna must be connected and placed in the same relative position to the chassis as when in cabinet.
- Use an isolation transformer if available, otherwise connect a .1 mfd. condenser in series with low side of signal generator and connect to chassis. Caution: Do not connect a ground wire directly to chassis.
- Connect output meter across speaker voice coil.
- Use lowest output setting of signal generator capable of producing adequate output meter indication and proceed in the following sequence.
- Repeat adjustments to insure good results.

Step	Dummy Antenna in Series with Signal Generator	Connection of Signal Generator (High Side)	Signal Generator Frequency	Receiver Gang Setting	Trimmer Description	Trimmer Designation	Type of Adjustment
1	250 mmfd. condenser	Tuning condenser, antenna stator	455 KC	Gang fully open	2nd IF 1st IF	*A, B *C, D	Maximum output
2	250 mmfd. condenser	Tuning condenser, antenna stator	1620 KC	Gang fully open	Oscillator	E	Maximum output

Mount dial pointer. Set pointer to horizontal position with tuning condenser tuned to 1400 KC generator signal (see illustration below). Rotate the tuning condenser until the pointer is in a vertical position (900 KC), then slip chassis in cabinet, carefully guiding the pointer so that it locates between the dial escutcheon and the cabinet. Install antenna and chassis mounting bolts. The pointer and escutcheon may be mounted after installing the chassis in cabinet as follows: Set pointer to horizontal position with gang tuned to 1400 KC signal. Place escutcheon on cabinet. With long nose pliers slip the hairpin ends of the escutcheon mounting springs in holes of escutcheon tabs.

3	Loop of several turns of wire, or place generator lead close to receiver antenna for adequate signal pickup.	No actual connection (signal by radiation)	1400 KC	Tune in generator signal	Antenna	†F	Maximum output
---	--	--	---------	--------------------------	---------	----	----------------

*Adjustments A and C made from the underside of the chassis. If IF transformers have hollow core slugs, these adjustments may all be made from the top of chassis, if you use alignment tool #98A30-7 obtainable from your Admiral distributor. The bottom IF slug adjustment may be reached through the hollow core in the upper slug.
 †Antenna Trimmer "F" should be aligned after chassis and antenna are mounted in cabinet.

TUBE AND TRIMMER LOCATION

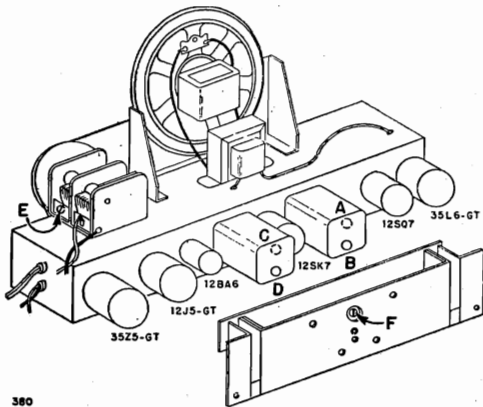

Adjustments A and C made from underside of chassis.

DIAL STRINGING AND POINTER SETTING

Dial stringing and pointer with solid lines shown with gang closed. Dashed line pointer positions (1400 KC and 900 KC) shown when tuning condenser is tuned to generator signal.

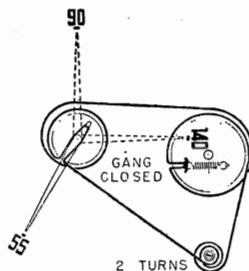

RECORD CHANGER SERVICE DATA

The changer model number will be found stamped at the top rear of the changer base and also on the changer model label.

Cartridge and Needle

As shown in the illustrations, alternate cartridges may be used. Cartridges are interchangeable when complete with needle.

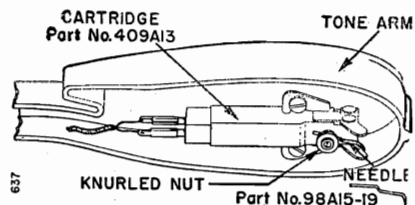
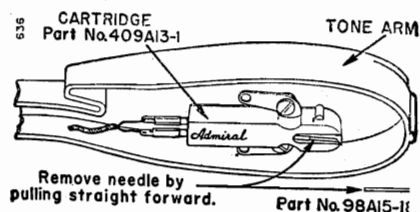

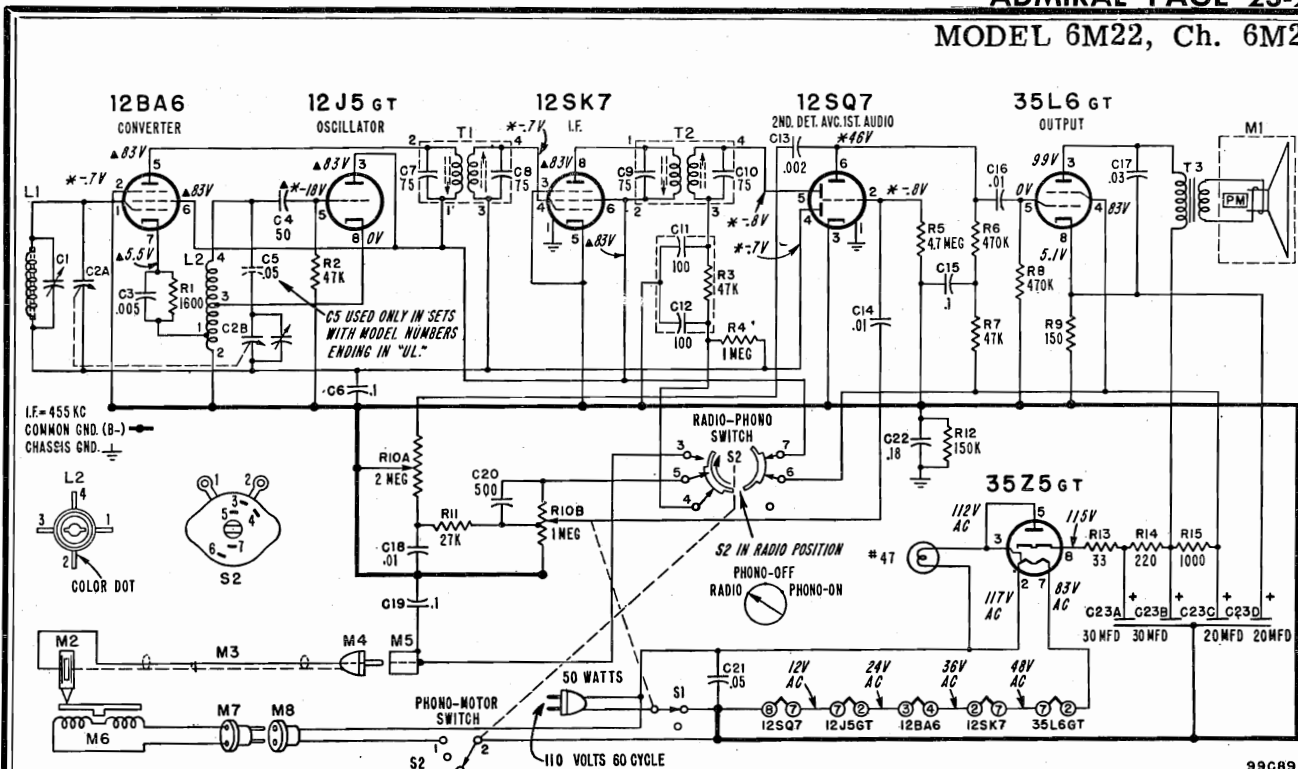

*These readings will be either lower or practically zero if taken with a 1000 ohm-per-volt meter.
▲ These readings will be zero on "Phono"; all other DC readings may be slightly higher.

VOLTAGE DATA

Voltages given on schematic diagram.

- All readings made between tube socket terminals and B minus (terminal of On-Off switch).
- Measured on 117 Volt 60 Cycle AC line.
- Switch S2 in "Radio" position.
- Volume control minimum; dial turned to low end.
- Voltages measured with Vacuum Tube Voltmeter.

RESISTORS

Symbol	Description	Part No.
R1	1,800 ohms, 1/2 watt, 5%	60B 7-162
R2	47,000 ohms, 1/2 watt	60B 8-473
†R3	47,000 ohms, 1/4 watt	
R4	1 megohm, 1/2 watt	60B 8-105
R5	4.7 megohms, 1/2 watt	60B 8-475
R6	470,000 ohms, 1/2 watt	60B 8-474
R7	47,000 ohms, 1/2 watt	60B 8-473
R8	470,000 ohms, 1/2 watt	60B 8-474
R9	150 ohms, 1 watt	60B 14-151
R10A	2 megohms, tone	75B 11-8
R10B	1 megohm, volume	
R11	27,000 ohms, 1/2 watt	60B 8-273
R12	150,000 ohms, 1/2 watt	60B 8-154
R13	33 ohms, 1 watt	60B 28-3
R14	220 ohms, 1 watt	60B 28-7
R15	1,000 ohms, 1 watt	60B 28-2

CONDENSERS

Symbol	Description	Part No.
C1	Trimmer, 3 to 30 mmfd.	Part of L1
§C2	Antenna and Oscillator gang	
C3	.005 mfd., min., Ceramic	65A 10-1
C4	50 mmfd., Ceramic	65B 6-4
C5	.05 mfd., 400 volts, paper	64B 1-22
C6	.1 mfd., 200 volts, paper	64B 1-30
C7	75 mmfd., 3%, Ceramic	Part of T1
C8	75 mmfd., 3%, Ceramic	Part of T1
C9	75 mmfd., 3%, Ceramic	Part of T2
C10	75 mmfd., 3%, Ceramic	Part of T2
†C11	100 mmfd., Ceramic	
†C12	100 mmfd., Ceramic	
C13	.002 mfd., 500 volts, paper	64B 1-14
C14	.01 mfd., 400 volts, paper	64B 1-25
C15	.1 mfd., 200 volts, paper	64B 1-30
C16	.01 mfd., 400 volts, paper	64B 1-25
C17	.03 mfd., 400 volts, paper	64B 1-23
C18	.01 mfd., 400 volts, paper	64B 1-25
C19	.1 mfd., 200 volts, paper	64B 1-30
C20	500 mmfd., Ceramic	65B 6-6
C21	.05 mfd., 400 volts, paper	64B 1-22
C22	.18 mfd., 200 volts, paper	64A 2-2
C23a	30 mfd., 150 volts	Elect. 67A 14-1
C23b	30 mfd., 150 volts	
C23c	20 mfd., 150 volts	
C23d	20 mfd., 150 volts	

COILS, TRANSFORMERS, ETC.

Symbol	Description	Part No.
§L1	Rod Antenna (includes board and C1)	
L2	Coil, Oscillator	69A 113-1
T1	Transformer, 1st IF	72B 50
T2	Transformer, 2nd IF	72B 51
T3	Transformer, Output	79A 11-3
M1	Speaker, (5" pm)	78B 39-3
M5	Socket, Phono input	88A 1
M8	Socket & Leads, Motor	89A 6-3
S1	Switch, On-Off	Part of R10B
S2	Switch, Radio-Phono	77A 28-1
	Switch, Phono Motor	Part of S2
†	Diode Filter	63A 3-1

MISCELLANEOUS

Description	Part No.
Carton and Fillers	44B 145
Clip, Electrolytic Mounting	18A 10-6
Speed Nut (esc. mtg.)	2B 10-35-68
Dial Cord	50A 1-3
Drum, Pointer	17A 27
Gasket, Sponge Rubber (mounts on Speaker)	12B 43
Grommet, Rubber (gang mtg.)	12A 1-2
Insulator, Phono Receptacle	32A 46
Manual	
Customer Instruction for 6J21, 6J22	41A 18-33
for 6M22	41A 18-47
Service, for RC550 Changer	S327
Pilot Light, #47	81A 1-8
Pilot Light Socket and Leads	82A 2-2
Plate, Pointer Support	15A 498
Pointer, Dial	25A 35-1
Shaft, Pointer	28A 42
Shield, Pilot Light (6J2 only)	82A 15-1
Sleeve, Pointer Shaft	27A 162-1
Sleeve, Tuning (Brass)	27A 123
Spacer, "T" (gang condenser mtg.)	29A 2-1-71
Spring, Dial Cord Tension	19B 1-5
Socket, Tube (12BA6)	87A 33-2
Washer, "C" (for pointer drum)	4A 4-6
Washer, Spring	4A 6-10-0

CABINET PARTS

Description	Part No.
Cabinet, Plastic	
Bottom, less lid (Ebony 6J21)	34D 28-3
Bottom, less lid (Mahogany 6J22, 6M22)	34D 28-5
Lid only (Ebony 6J21)	34D 28-4
Lid only (Mahogany 6J22, 6M22)	34D 28-6

PHONOGRAPH PARTS

Description	Part No.
Clamp, Cable	11A 2-2
Escutcheon, Dial for 6J21, 6J22	23C 81-1
for 6M22	23C 51-1
Escutcheon Ring (Gold trim)	23A 53
Hinge	37A 8-1
Hinge Screw (6/32x1/4 BH MS)	365-250-C2-58
Hinge Stud	27A 17-1
Jewel, Pilot Light	82A 14-2
Knob, Radio, for Ebony 6J21	
"Off-On Volume" (inner knob)	33C 55-22
"Tone" (outer knob)	33C 55-21
"Radio-Phono" (inner knob)	33C 55-20
"Tuning" (outer knob)	33C 55-19
Knob, Radio, for Mahogany 6J22	
"Off-On Volume" (inner knob)	33C 55-18
"Tone" (outer knob)	33C 55-17
"Radio-Phono" (inner knob)	33C 55-16
"Tuning" (outer knob)	33C 55-15
Knob, Radio, for Mahogany 6M22	
"Off-On Volume" (inner knob)	33C 55-10
"Tone" (outer knob)	33C 55-9
"Radio-Phono" (inner knob)	33C 55-8
"Tuning" (outer knob)	33C 55-7
Rubber Bumper for cabinet bottom	12A 3-4
for cabinet top	12A 9-8
Stay Arm and Plate	37A 9-1
Washer, Felt (for tuning knobs)	5A 4-9

Symbol	Description	Part No.
M2	Cartridge Pickup (includes needle)	409A 13
M3	Cable, Shielded Pickup (includes plug)	413A 11-1
M4	Plug, Pickup Cable	88A 2-3
M6	Motor, Phono (3 speed)	407B 19
M7	Plug, Motor (Male)	88A 8-1
M7	Adapter, 45 RPM (envelope of 12)	48A 8-1
	Button, Snap-in Plug	13A 2-8-57
	Centerpost, Record	G400B 505-1
	Idler Wheel (includes tire)	G400A 279
	Needle, Pickup for 409A13 cartridge	98A 15-19
	for 409A13-1 cartridge	98A 15-18
	Needle Retaining Nut (for 409A13 cartridge)	98A 54-2
	Service Manual, RC550 Changer	S327
	Screw and Washer, Changer Mounting (10-32x1/4 RH MS)	AA210
	Spring, Changer Float	19A 10-3

† Part of Diode Filter 63A3-1. This unit consisting of C11, C12 and R3 may be replaced with individual components.

§ 6M2 chassis use part number 68B30-1 gang (antenna 324 mmfd. max., oscillator 108 mmfd. max.) with part number 69B144

SPECIFICATIONS

CIRCUIT

5 tube AC-DC Superheterodyne covering two bands, 540 KC to 1730 KC and 5.8 MC to 18 MC (16 to 52 meters).

OPERATING VOLTAGE

110-120 Volts AC or 110-120 Volts DC. It can be operated on 220 Volts AC or DC only if a special line resistance cord is used. (See Parts List.)

ALIGNMENT PROCEDURE

- Connect output meter across voice coil.
- Turn receiver volume control full on.
- Use an isolation transformer if available, otherwise connect a .1 mfd. condenser in series with low side of signal generator and attach to B minus of chassis.
- Use lowest output setting of signal generator capable of producing adequate output meter indication and then proceed as outlined in chart below.
- Repeat adjustments to insure good results.

Step	Dummy Antenna in Series with Signal Generator	Connection of Signal Generator (High Side)	Band Switch Position	Signal Generator Frequency	Receiver Gang Setting	Trimmer Description	Trimmer Designation	Type of Adjustment
1	250 mmfd. condenser	Grid Cap 12A8 Tube	BC	455 KC	Gang fully open	2nd IF 1st IF	*A, B *C, D	Maximum Output
2	250 mmfd. condenser	End of Ant. Wire	BC	1730 KC	Gang fully open	BC Oscillator (on gang)	E	Maximum Output
3	250 mmfd. condenser	End of Ant. Wire	BC	1400 KC	Tune in generator signal	BC Antenna (on gang)	F	Maximum Output
4	250 mmfd. condenser	End of Ant. Wire	BC	600 KC	Tune in generator signal	BC pad	G	Maximum Output. Rock gang while adjusting
Recheck alignment at 1400 KC (in step 3 above)								
5	400 ohm carbon resistor	End of Ant. Wire	SW	15 MC	Tune in generator signal	SW Antenna	†H	Maximum Output. Rock gang while adjusting

* Adjustments A and C are made from underside of chassis.

† Be sure that trimmer is aligned at correct frequency and not on image which should be approximately 910 KC lower than correct frequency, as indicated on the dial. Check to see that image appears 910 KC lower than alignment frequency.

TUBE AND TRIMMER LOCATION

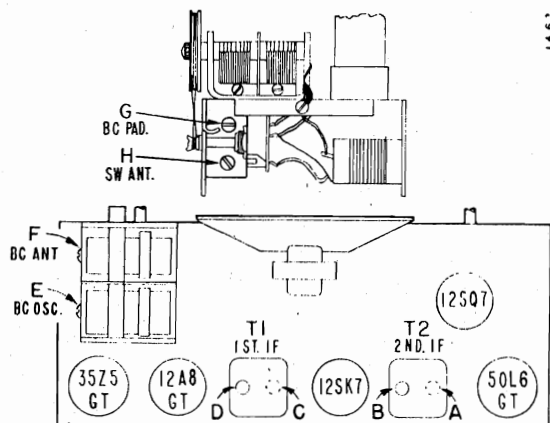

POINTER SETTING AND DIAL CORD STRINGING

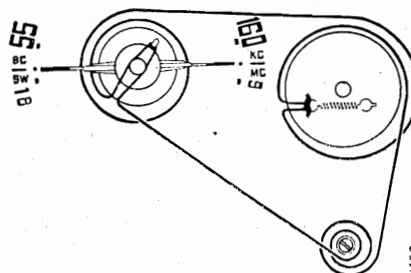

S442

RESISTORS

Symbol	Description	Part No.
R1	47,000 ohms, ½ watt.....	60B 8-473
R2	330 ohms, ½ watt.....	60B 8-331
R3	39,000 ohms, ½ watt.....	60B 8-393
R4	3,300 ohms, ½ watt.....	60B 8-332
R5	150,000 ohms, ½ watt.....	60B 8-154
R6	2.2 megohms, ½ watt.....	60B 8-225
R7	1 megohm, Volume Control.....	75B 1-40
R8	4.7 megohms, ½ watt.....	60B 8-475
*R9	500,000 ohms, ½ watt	
*R10	500,000 ohms, ½ watt	
R11	150 ohms, ½ watt.....	60B 8-151
R12	33 ohms, 1 watt.....	60B 28-3
R13	150 ohms, 1 watt.....	60B 28-1
R14	1,000 ohms, 1 watt.....	60B 28-2

CONDENSERS

C1	.001 mfd, min, ceramic disc.....	65C 10-6
C2	50 mfd, mica.....	65B 5-11
C3A	3 to 30 mmfd. } Dual	66A 23-4
C3B	450 to 510 mmfd. } Trimmer	
C4A	420 mmfd, max, Ant. } Gang	68B 45-1
C4B	420 mmfd, max, Osc. } (Dial drum spotwelded to gang)	
C5	.003 mfd, 3%, silver mica.....	65B 1-6
C6	10 mfd, Zero temp. coeff, ceramic.....	65C 6-44
C7	100 mfd, —.00075 temp coeff, ceramic.....	65C 6-19
C8	.005 mfd, min, ceramic disc.....	65C 10-1
C9	.047 mfd, 400 volts, paper.....	64B 5-22
C10	.047 mfd, 400 volts, paper.....	64B 5-22
C11	.047 mfd, 400 volts, paper.....	64B 5-22
C12	.2 mfd, 400 volts, paper.....	64B 5-19
C13	250 mmfd, ceramic.....	65C 6-5
C14	.01 mfd, min, ceramic disc.....	65C 10-3
C15	.047 mfd, 400 volts, paper.....	64B 5-22
*C16	250 mmfd, 500 volts	
*C17	.01 mfd, 400 volts	
C18	.01 mfd, min, ceramic disc.....	65C 10-3
C19	.047 mfd, 400 volts, paper.....	64B 5-22
C20A	30 mfd, 150 volts	Elect.....67B 23-1
C20B	30 mfd, 150 volts	
C20C	20 mfd, 150 volts	

COILS, TRANSFORMERS, ETC.

L1	Coil, Antenna BC.....	69A 74
L2	Coil, Antenna SW.....	69B 75-1
L3	Coil, Oscillator BC and SW.....	69B 76-1
T1	Transformer, 1st IF.....	72B 50

* Part of couplate (part number 63A5-1). Replace with exact duplicate or individual components. Note that numbers 1, 2, 3, 4, on schematic correspond to lead numbers printed on face of couplate.

Symbol	Description	Part No.
T2	Transformer, 2nd IF.....	72B 51
T3	Transformer, Output.....	98A 4
S1	Switch, Band.....	77A 32-3
S2	Switch, On-Off.....	Part of R7
M1	Speaker (5" PM) and Output Transformer.....	78B 62-1
	Couplate.....	63A 5-1

MISCELLANEOUS

Description	Part No.
Antenna Hank (20' length).....	89A 4-2
Back, Cabinet.....	43B 170
Baffle Ring, Speaker.....	43A 154
Bracket, Band Switch Mounting.....	15A 393
Cabinet	
Mahogany (5A22).....	34D 39-5
Ivory (5A23).....	34D 39-6
Carton and Fillers.....	44B 191
Dial Cord (32" length needed).....	50A 1-3
Drum, Dial Pointer.....	17A 32
Escutcheon, Dial Scale.....	23C 77-2
Felt Washer (Knob).....	5A 4-11
Grille, Speaker (Metal).....	16A 30-2
Grommet, Rubber (for mtg. gang).....	12A 1-2
Knob, Band Switch (Inner Knob)	
Maroon (for 5A22).....	33B 39-27
Ivory (for 5A23).....	33B 39-30
Knob, Off-On Volume	
Maroon (for 5A22).....	33B 39-29
Ivory (for 5A23).....	33B 39-32
Knob, Tuning (Outer Knob)	
Maroon (for 5A22).....	33B 39-28
Ivory (for 5A23).....	33B 39-31
Pointer, Dial.....	25A 51-1
Resistance Cord, for 220 V. operation with American Male Plug.....	89A 14
with Continental Male Plug.....	89A 14-1
Shaft, Pointer.....	28A 42-1
Sleeve, Metal	
for mtg. dial pointer.....	27A 162-1
for mtg. gang condenser.....	29A 2-1-71
Sleeve, Tuning Shaft.....	27A 156
Socket, Tube.....	87A 5-1
Spacer, Tuning Shaft.....	29A 2-1-71
Speed Nut (for mtg. escutcheon).....	2B 10-35-68
Spring, Dial Cord Tension.....	19B 1-2
Washer, "C" (Tuning Shaft).....	4A 4-6

VOLTAGE DATA

Voltages shown on schematic diagram.

- All readings made between tube socket terminals and B minus (terminal of On-Off switch).
- Dial turned to low frequency end; volume control at minimum.
- Band switch set in "BC" position.
- Measured on 117 volts AC line.
- Voltages measured with Vacuum Tube Voltmeter.

MODELS 5X21, 5X22, 5X23, Ch. 5X2

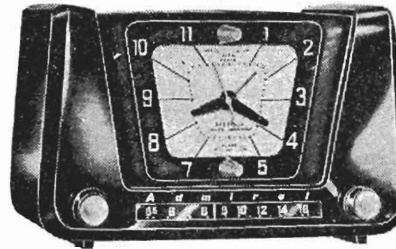

Model 5X21 Ebony, 5X22 Mahogany, 5X23 Ivory
Operating Voltage: 117 volts AC only.
Power: 30 watts.

ALIGNMENT PROCEDURE

- Turn receiver volume control full on (fully clockwise).
- Use an isolation transformer if available, otherwise connect a .1 mfd. condenser in series with low side of signal generator and connect to chassis.
Caution: Do not connect a ground wire directly to chassis.
- Connect output meter across speaker voice coil.
- Use lowest output setting of signal generator capable of producing adequate output meter indication and proceed in the following sequence.
- Use a NON-METALLIC alignment tool for IF transformers. See asterisk * note below.
- Repeat adjustments to insure good results.

Step	Dummy Antenna in Series with Signal Generator	Connection of Signal Generator (High Side)	Signal Generator Frequency	Receiver Gang Setting	Trimmer Description	Trimmer Designation	Type of Adjustment
1	250 mmfd. condenser	Antenna stator of tuning condenser	455 KC	Gang fully open	2nd IF 1st IF	*A, B *C, D	Maximum output
2	250 mmfd. condenser	Antenna stator of tuning condenser	1620 KC	Gang fully open	Oscillator (on gang)	E	Maximum output
3	Loop of several turns of wire, or place generator lead close to receiver antenna for adequate signal pickup.	No actual connection (signal by radiation)	1400 KC	Tune in generator signal	Antenna (on gang)	F	Maximum output

*Adjustments A and C made from the underside of the chassis. To avoid splitting the slotted head of the powdered iron core tuning slugs in IF transformers, use an alignment tool having a blade $\frac{1}{8}$ " wide.

TUBE AND TRIMMER LOCATION

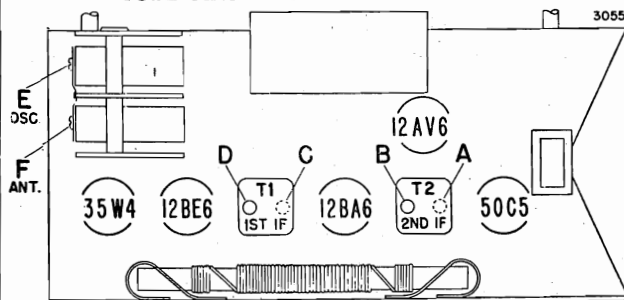

Adjustments A and C made from underside of chassis.

OPERATING THE RADIO

The radio is turned on manually when the "Off-Auto-On" switch is set to the "ON" position. The radio is turned on and off automatically when the switch is set to the "AUTO" position.

REMOVING THE CLOCK FROM CABINET

- To remove the clock, proceed as follows:
1. Remove the radio chassis from the cabinet.
 2. Remove the two hexagonal nuts and lock washers which mount the clock movement to the metal cover.
 3. Carefully remove the clock movement from the cover. Do not unsolder leads unless complete removal of the clock is required. The metal cover mounting the clock to the chassis may be removed if more space is required for servicing the clock.

REPLACING THE CLOCK MOTOR

To remove the clock motor, press the motor inwardly and rotate it to the left (counterclockwise).

Mount the clock motor by pressing the motor inwardly and rotating it to the right (clockwise).

Caution: The gear on the motor must mesh with the fiber gear on the clock mechanism. If the gears are not properly meshed, damage may result.

DIAL STRINGING AND POINTER SETTING

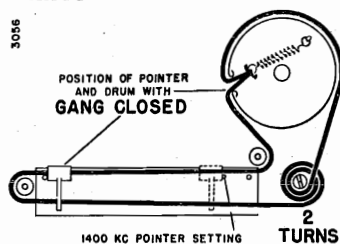

Dial stringing and pointer setting is shown with the gang condenser closed. The 1400 KC pointer setting is shown in dashed lines.

S487

MODELS 5X21, 5X22, 5X23, Ch. 5X2

C9 AND C10 TOTAL 250 MMFD. WHEN REPLACING WITH INDIVIDUAL COMPONENTS, USE ANY COMBINATION TOTALING 250 MMFD OR USE 250 MMFD ACROSS R6 IN PLACE OF C9 AND C10. R6 AND R7 CAN BE 470K.

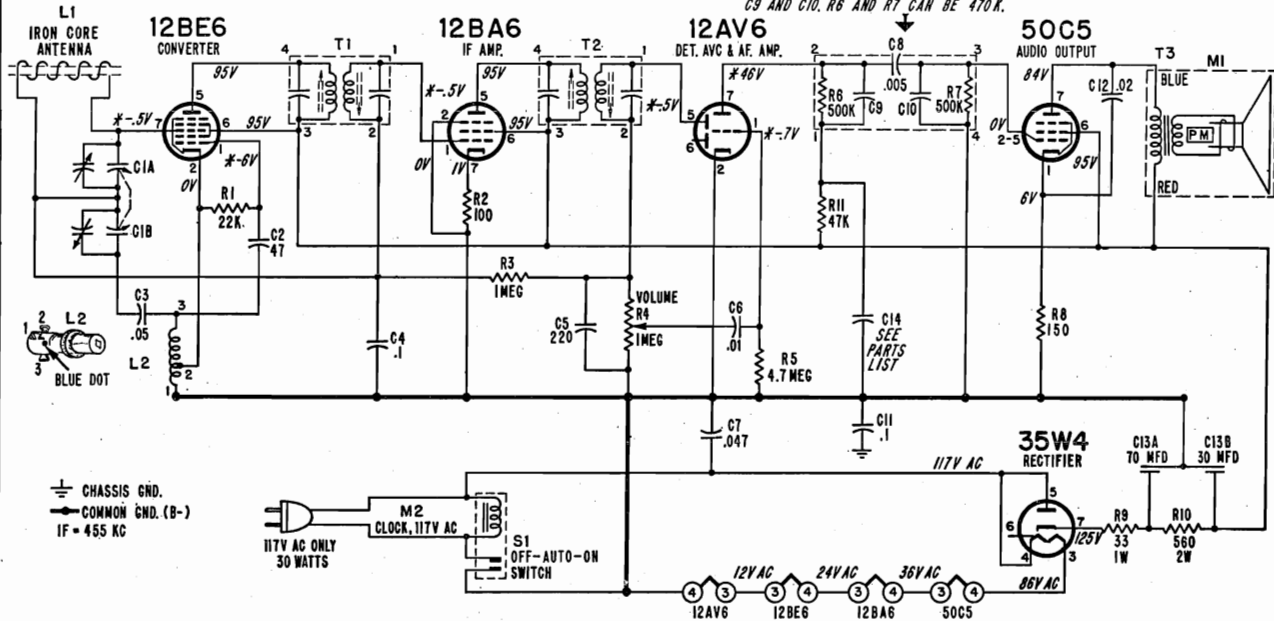

*These voltage readings will be either lower or practically zero if taken with a 1000 ohm-per-volt meter.

VOLTAGE DATA

Voltages shown on schematic diagram.

- All readings made between tube socket terminals and B minus (negative of electrolytic condenser C13).
- Measured on 117 Volt AC line.
- Volume control minimum; dial turned to low frequency end.
- Voltages measured with Vacuum Tube Voltmeter.

RESISTORS

Symbol	Description	Part No.
R1	22,000 ohms, 1/2 watt	60B 8-223
R2	100 ohms, 1/2 watt	60B 8-101
R3	1 megohm, 1/2 watt	60B 8-105
R4	1 megohm, Volume control	75B 1-51
R5	4.7 megohms, 1/2 watt	60B 8-475
R6	500,000 ohms, 1/2 watt	
R7	500,000 ohms, 1/2 watt	
R8	150 ohms, 1/2 watt	60B 9-151
R9	33 ohms, 1 watt	60B 28-3
R10	560 ohms, 2 watts	60B 20-561
R11	47,000 ohms, 1/2 watt	60B 8-473

CONDENSERS

Symbol	Description	Part No.
C1A	290 mmfd, max. Ant. } gang	68B 51
C1B	104 mmfd, max. Osc. } (Dial drum spot welded to gang)	
C2	47 mmfd, ceramic	65C 6-79
C3	.05 mfd, 400 volts, paper	64B 1-7
C4	.1 mfd, 200 volts, paper	64B 1-5
C5	220 mmfd, ceramic	65C 6-80
C6	.01 mfd, 400 volts, paper	64B 1-10
C7	.047 mfd, 400 volts, paper	65A 13-5
C8	.005 mfd, 450 volts	
C9	{ See note on schematic.	
C10	.1 mfd, 200 volts, paper	64B 1-5
C11	.02 mfd, 400 volts, paper	64B 1-9
C13A	70 mfd, 150 volts } elect.	67A 17-1
C13B	30 mfd, 150 volts }	

*Part of couplate (part number 63A5-4). Re place with exact duplicate or individual components. Note that numbers 1, 2, 3, 4 on schematic correspond to lead numbers printed on face of couplate.

Symbol	Description	Part No.
C14	{ 4 mfd, 150 volts, elect. (in early sets) } 67A 4-2	
	{ .25 mfd, 200 volts, paper (in later sets) } 64B 1-3	

COIL, TRANSFORMERS, ETC.

Symbol	Description	Part No.
L1	Rod Antenna and Cabinet Back	69C 157
L2	Coil, Oscillator	69A 52-4
T1	Transformer, 1st IF	72B 28-7
T2	Transformer, 2nd IF	72B 28-7
T3	Transformer, Output	98A 4
M1	Speaker (4" PM) and Output Transformer	78B 65-3
S1	Switch, Off-Auto-On (part of clock)	91C 6-16
	Couplate	63A 5-4 (includes R6, R7, C8, C9, C10)

MISCELLANEOUS PARTS

Description	Part No.
Carton and Fillers	44B 259
Clip, IF Transformer Mounting	72B 28-10
Dial Background	15B 840
Dial Cord (27" length needed)	50A 1-3
Grommet, Rubber (for mounting gang)	12B 1-19
Manual, Operating Instructions	41B 20-12
Pointer, Dial	25A 49-2
Shaft, Tuning	28A 26-7
Sleeve, Tuning Shaft	27A 124-1
Snap Button (for mtg. cabinet back)	13A 1-5-71
Socket, Tube plain	87A 24-2
with grounding strap	87A 24-3
Spacer, Metal (for mounting gang)	29A 2-3-24

Description	Part No.
Speed Nut (for mounting tuning shaft sleeve)	2B 10-21-59
Spring, Dial Cord Tension	19C 1-5
Washer, "C" (for tuning shaft)	4A 4-5

CABINET PARTS

Description	Part No.
Cabinet, Plastic	
Ebony	34D 55-1
Mahogany	34D 55-2
Ivory	34D 55-3
Escutcheon, Dial Scale	21B 63
Grille Cloth and Baffle Board	
Ebony	AA227-5
Mahogany	AA227-6
Knob, Radio	
Ebony	33A 81-1
Mahogany	33A 81-3
Ivory	33A 81-2
Washer, Felt (for radio knobs)	5A 4-19

CLOCK PARTS

Symbol	Description	Part No.
M2	Clock, Complete for 117 volts, 60 cycles	91C 8-1
	for 117 volts, 50 cycles	91C 8-2
Knob, Clock		
Ebony		91C 8-11
Mahogany		91C 8-12
Ivory		91C 8-13
Motor, Clock		
for 117 volts, 60 cycles		91C 6-14
for 117 volts, 50 cycles		91C 6-15
Snap Button (for mtg. clock window)		13A 1-4
Window (plastic)		24B 12

MODELS 5S21AN,
5S22AN, 5S23AN,
Ch. 5C3

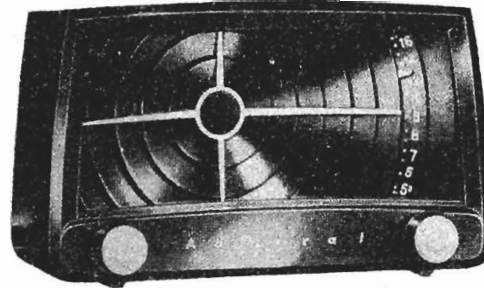

Models 5S21AN Ebony, 5S22AN Mahogany
and 5S23AN Ivory

GENERAL

This receiver employs the very latest in radio circuitry and printed circuit wiring technique. The printed circuit wiring used in this receiver replaces the hookup wire type of circuit wiring used in earlier receivers. See figures 1 and 2. The printed circuit wiring is permanently adhered to the underside of the plastic chassis base by a photo engraving process. This new method of wiring has produced greater uniformity of chassis wiring, fewer wiring troubles and simplifies circuit tracing and trouble shooting. All circuit components are of standard size and design. For servicing convenience, all parts are mounted on the top side of the chassis; see figure 3. Audio circuit components are contained in a printed circuit couplate.

Trouble shooting and parts replacement will in general be the same as for receivers wired with hookup wire. However, when servicing, it is important to read the service information given in this manual with respect to servicing technique printed circuit receivers. A top view of the chassis is shown in figure 3. A bottom view of early and later production chassis is shown in figures 1 and 2. The early and later production chassis have some minor differences in the routing of the printed circuit wiring but however, are the same electrically.

REPLACEMENT OF COMPONENTS

All components used in this receiver are of standard size and design. For servicing convenience, all components are mounted on the top side of the chassis, see figure 3.

To avoid damage to printed circuits by application of excessive heat when replacing components, use a soldering iron (60 watts or less) with a small tip. Do not use a soldering gun.

To remove a defective component, apply the tip of the soldering iron to the connection point at the underside of the chassis. Keep soldering iron on connection just long enough to melt the solder, then quickly tap the chassis against the service bench to shake the solder away from the connection. After the solder is removed, untwist or separate connections. A pick will be helpful for untwisting or separating connections. After disconnecting connecting wires or lugs, carefully remove components from the top side of the chassis.

Before installing replacement components, clean the solder from the connection point, so that the leads or lugs can be pushed through the holes in the chassis panel. To avoid running solder into adjacent leads of the printed circuit, use as little solder as possible.

For quick replacement, resistors and condensers may be replaced by clipping out the defective part and soldering the new part to the connecting leads remaining from the original part.

An open or damaged section of printed circuit wiring can be replaced by soldering a jumper of ordinary hookup wire across the connection points. To avoid need for complete tube socket replacement, defective tube socket pin clips may be replaced individually. Tube socket pin clips are available under part number 87A35-2.

Note: The tubular shield (center connection) at the bottom of each tube socket must be securely soldered to the printed circuit wiring, otherwise hum or oscillation will result.

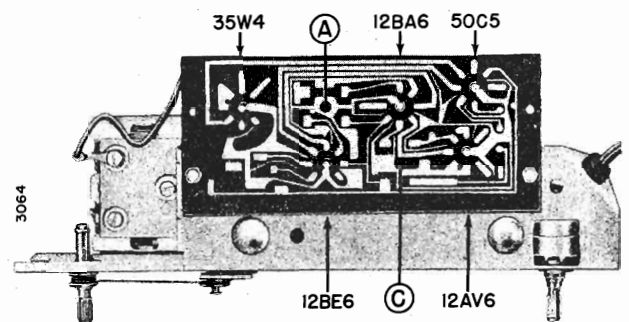

Figure 1. Bottom View of (Early Production) Chassis.

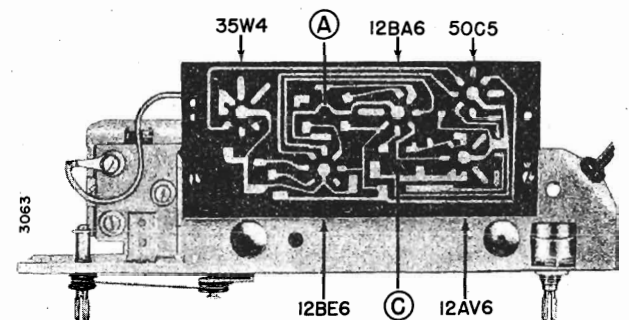

Figure 2. Bottom View of (Later Production) Chassis.

ALIGNMENT PROCEDURE

- Connect output meter across speaker voice coil.
- Turn receiver volume control full on.
- Use an isolation transformer if available, otherwise connect a .1 mfd. condenser in series with low side of signal generator and connect to chassis.
- Caution: Do not connect a ground wire directly to chassis.
- Use lowest output setting of signal generator capable of producing adequate output meter indication and then proceed as outlined in chart below.
- Use a NON-METALLIC alignment tool for IF transformers.
- Repeat adjustments to insure good results.

Step	Dummy Antenna in Series with Signal Generator	Connection of Signal Generator (High Side)	Signal Generator Frequency	Receiver Gang Setting	Trimmer Description	Trimmer Designation	Type of Adjustment
1	250 mmfd. condenser	Antenna stator of tuning condenser	455 KC	Gang fully open	2nd IF 1st IF	*A, B *C, D	Maximum Output
2	250 mmfd. condenser	Antenna stator of tuning condenser	1620 KC	Gang fully open	Oscillator (on gang)	E	Maximum Output
3	Loop of several turns of wire or place generator lead close to receiver loop for adequate signal pickup.	No actual connection (signal by radiation)	1400 KC	Tune in generator signal	Antenna (on gang)	F	Maximum Output
4	Set dial pointer slide as shown in Pointer Setting and Dial Cord Stringing Diagram below. Also see instructions below on "Removing Or Installing Chassis In Cabinet" and on "Setting Pointer Slide."						

*Adjustments A and C made from the underside of the chassis. To avoid splitting the slotted head of powdered iron core tuning slugs in IF transformers, use an alignment tool with a blade 1/8" wide.

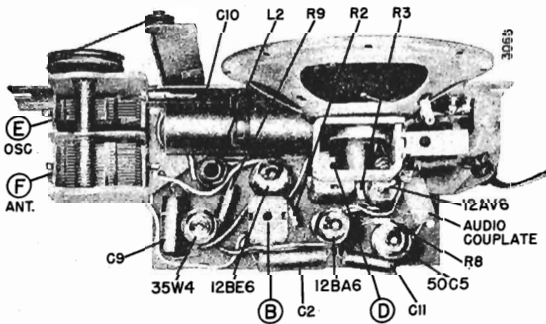
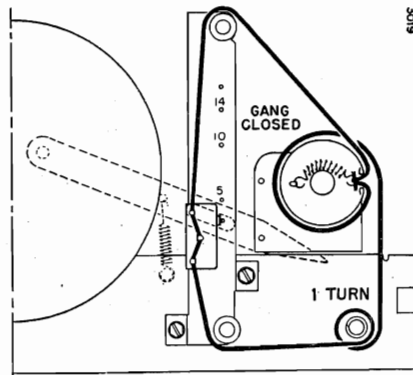

Figure 3. Top View of Chassis. Location of Components and Alignment Adjustments Shown. Adjustments A and C made from underside. See figures 1 and 2.

REMOVING OR INSTALLING CHASSIS IN CABINET

Fully close the gang condenser before removing or installing the chassis in the cabinet. When installing, carefully slide the chassis in the cabinet, so that the tab on the pointer slide fits into the elongated hole at the center of the dial pointer. See the "Pointer Setting and Dial Stringing" diagram at the right. Parts which are shown in dotted lines are not assembled to the chassis. These parts are mounted on the inside of the cabinet.

POINTER SETTING AND DIAL CORD STRINGING



SETTING POINTER SLIDE

With the gang condenser fully closed, line up the center of the pointer slide with the bottom hole in the pointer slide bracket as shown in the figure above.

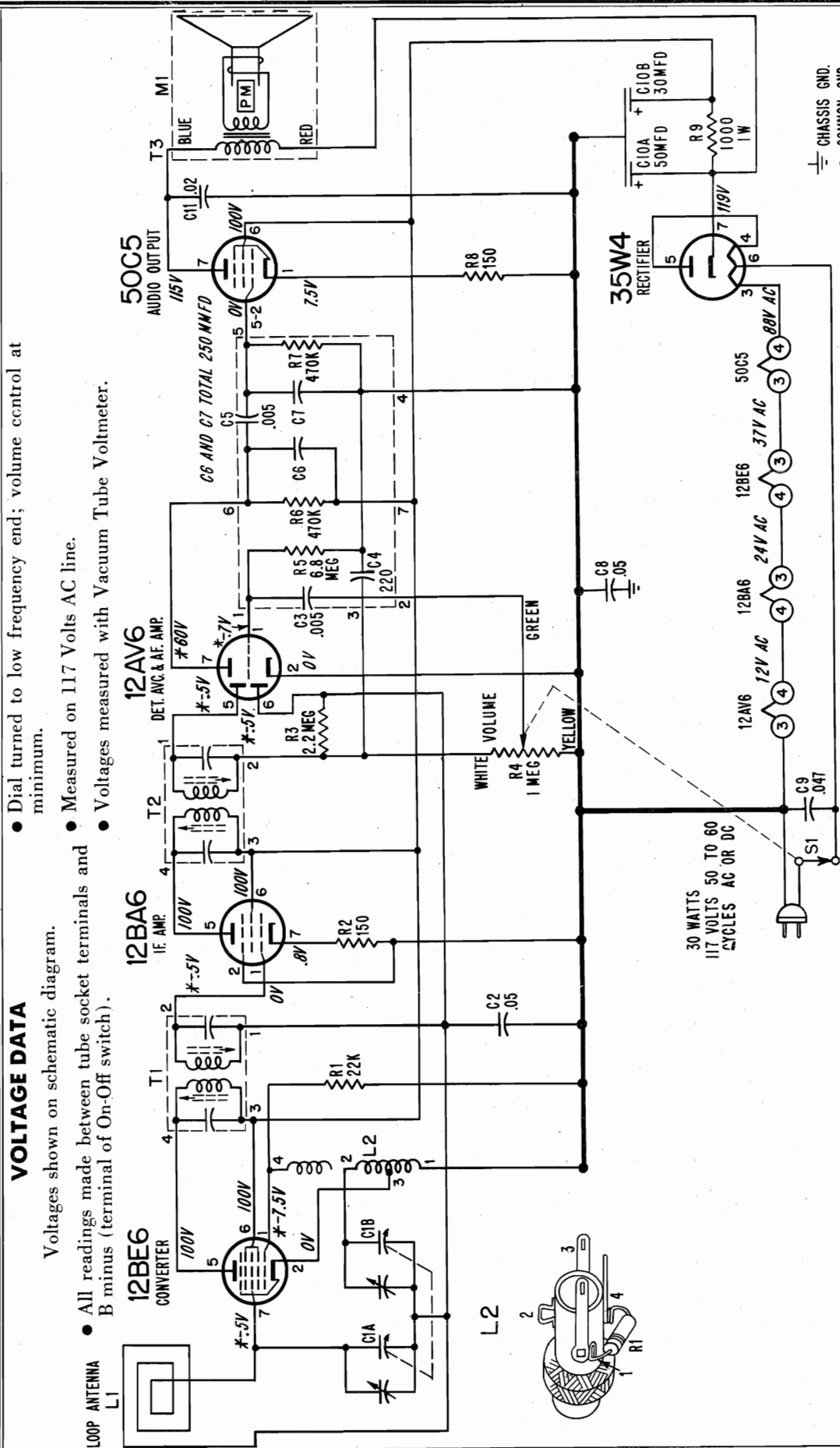

- VOLTAGE DATA**
 Voltages shown on schematic diagram.
- Dial turned to low frequency end; volume control at minimum.
 - Measured on 117 Volts AC line.
 - Voltages measured with Vacuum Tube Voltmeter.

- All readings made between tube socket terminals and B minus (terminal of On-Off switch).

CHASSIS GND.
 COMMON GND.
 IF=455 KC

VOLTAGE PRECAUTION

The chassis of this receiver is connected directly to one side of the power line. To avoid possibility of damage to test equipment or to printed circuit wiring, do not place the chassis directly on a metal service bench, tools or other metal objects.

When taking voltage readings or making resistance measurements, use test leads with needle point prods to avoid possibility of short circuit between sections of the printed circuit wiring.

SPECIFICATIONS

Circuit: Superheterodyne using 5 miniature tubes. See additional circuit information on front page.

Frequency Range: Standard broadcast band, 535 to 1620 KC.

Intermediate Frequency: 455 KC.

Power Supply: Power line of 117 volts, 50 to 60 cycles AC or DC.

Power Consumption: 30 watts.

Antenna: Built-in loop antenna.

Speaker: 5" PM, with Alnico V magnet. Voice coil impedance, 3.2 ohms.

COILS, TRANSFORMERS, ETC.

L1	Antenna, Loop.....	69C	159
	(mounted on cardboard back)		
L2	Coil, Oscillator.....	69A	158-1
	(includes R1)		
T1	Transformer, 1st IF.....	72B	28-63
T2	Transformer, 2nd IF.....	72B	28-63
T3	Transformer, Output.....	98A	4
M1	Speaker (5" PM) and Output Transformer.....	78B	26-3
S1	Switch, On-Off.....	Part of R4	
	Couplate.....	63B	6-7
	(Includes R5, R6, R7, C3, C4, C5, C6, C7)		

RESISTORS

Symbol	Description	Part No.
R1	22,000 ohms, 1/2 watt.....	60B 8-223
R2	150 ohms, 1/2 watt.....	60B 8-151
R3	2.2 megohms, 1/2 watt.....	60B 8-225
R4	1 megohm, Volume control.....	75B 1-52
	(includes switch S1)	
§R5	6.8 megohms, 1/2 watt	
§R6	470,000 ohms, 1/2 watt	
§R7	470,000 ohms, 1/2 watt	
R8	150 ohms, 1/2 watt.....	60B 8-151
R9	1,000 ohms, 1-watt.....	60B 28-2

CONDENSERS

C1A	420 mmfd, max, Ant. }	} gang.....68B 48
C1B	108 mmfd, max, Osc. }	
	(Dial drum spot welded to gang.)	
C2	.05 mfd, 400 volts, paper.....	64B 1-7
§C3	.005 mfd, 450 volts	
§C4	220 mmfd, 450 volts	
§C5	.005 mfd, 450 volts	
§C6	{ See note on	
§C7	{ schematic.	
C8	.05 mfd, 400 volts, paper.....	64B 1-7
C9	.047 mfd, 400 volts, paper.....	65A 13-5
C10A	50 mfd, 150 volts }	} elect.67A 10
C10B	30 mfd, 150 volts }	
C11	.02 mfd, 400 volts, paper.....	64B 8-11

MISCELLANEOUS PARTS

Bracket, Pointer Slide (incl. pulleys).....	A3730
Cabinet, Plastic	
Ebony.....	34D 26-12
Mahogany.....	34D 26-13
Ivory.....	34D 26-14
Carton and Fillers.....	44B 236
Dial Background.....	22A 30
Dial Cord (27" length needed).....	50A 1-3
Grommet (for mtg. gang).....	12A 1-19
Grommet (for mtg. tuning shaft).....	12A 1-21
Knob, Tuning	
Ebony.....	33A 81-1
Mahogany.....	33A 81-3
Ivory.....	33A 81-2
Pointer, Dial.....	25A 52
Shaft, Tuning.....	28A 26-6
Slide, Pointer.....	15A 800
Snap Button	
for mtg. pointer to cabinet.....	13A 1-2-59
for mtg. dial background.....	13A 1-3-59
Socket, Tube.....	87A 35-1
Spacer, Metal "T" (for mtg. gang).....	29A 2-1-24
Spacer, Tuning Shaft.....	29A 2-7-24
Speed Nut (for tuning shaft spacer).....	2B 10-19-27
Spring, Dial Cord Tension.....	19C 1-2
Spring, Pointer Tension.....	19C 1-20
Washer, "C" (for tuning shaft).....	4A 4-6-0
Washer, Spring (for tuning shaft).....	4A 6-3-0
Washer, Spring (for pointer).....	4A 6-5

§Part of couplate, part number 63B6-7. Numbers 1, 2, 3, 4 on schematic correspond to lead numbers printed on face of couplate 63B6-7.

MODELS 6C22, 6C22A, 6C23, 6C23A, Ch. 6C2, 6C2A

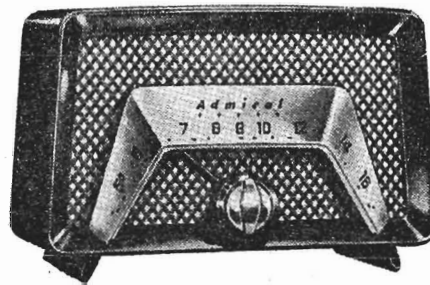

6C22, 6C22A Mahogany, 6C23, 6C23A Ivory
Operating Voltage: 117 volts, 50 to 60 cycles, AC or DC. Power: 30 watts.

ALIGNMENT PROCEDURE

- Turn receiver volume control full on.
 - Use an isolation transformer if available, otherwise connect a .1 mfd. condenser in series with low side of signal generator and connect to B minus (terminal of On-Off switch).
 - Connect output meter across speaker voice coil.
 - Use lowest output setting of signal generator capable of producing adequate output meter indication and then proceed as outlined in chart below.
 - Repeat adjustments to insure good results.
 - Use a non-metallic alignment tool for IF transformers.
- Caution: Do not connect a ground wire directly to chassis.

Step	Dummy Antenna in Series with Signal Generator	Connection of Signal Generator (High Side)	Signal Generator Frequency	Receiver Gang Setting	Trimmer Description	Trimmer Designation	Type of Adjustment
1	250 mmfd. condenser	Pin 8 of 12SA7 tube	455 KC	Gang fully open	2nd IF 1st IF	*A, B *C, D	Maximum Output
2	250 mmfd. condenser	Tuning condenser Antenna stator	1620 KC	Gang fully open	Oscillator (on gang)	E	Maximum Output
3	Loop of several turns of wire, or place generator lead close to receiver antenna for adequate signal pickup.	No actual connection (signal by radiation)	1400 KC	Tune in generator signal	RF (on gang)	F	Maximum Output
4	"	No actual connection (signal by radiation)	1400 KC	Tune in generator signal	Antenna (on gang)	G	Maximum Output

*Adjustments A and C are made from underside of chassis.

POINTER SETTING AND DIAL CORD STRINGING

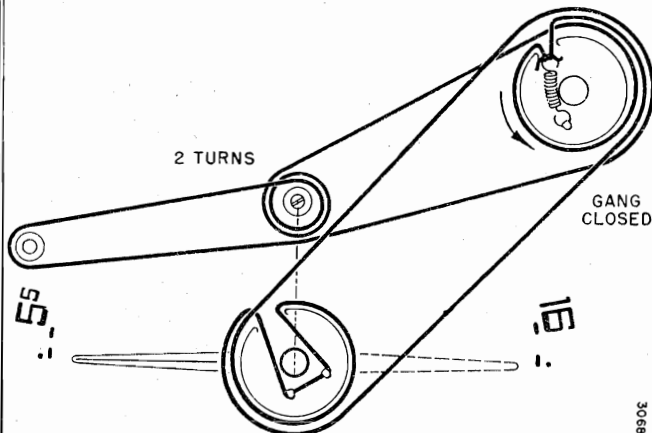

POINTER SETTING

Before installing the chassis in the cabinet, fully close the gang condenser. Slide the chassis in the cabinet and mount the dial pointer in a horizontal position (pointed at the dot and dash below 55 on the radio dial scale).

TUBE AND TRIMMER LOCATION

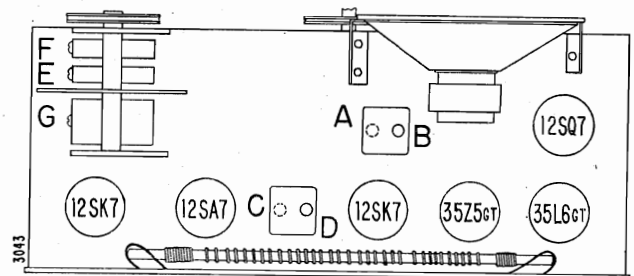

Adjustments A and C are made from underside of chassis.

DIAL STRINGING

When stringing the dial cord, the gang condenser and pointer drum must be in the position shown in the dial stringing and pointer setting diagram at right. Starting at the tension spring on the gang condenser drum, string the dial cord in the direction shown by the arrows. Maintain sufficient tension on the dial cord tension spring to prevent slipping of the dial cord.

MODELS 6C22, 6C22A, 6C23, 6C23A, Ch. 6C2, 6C2A

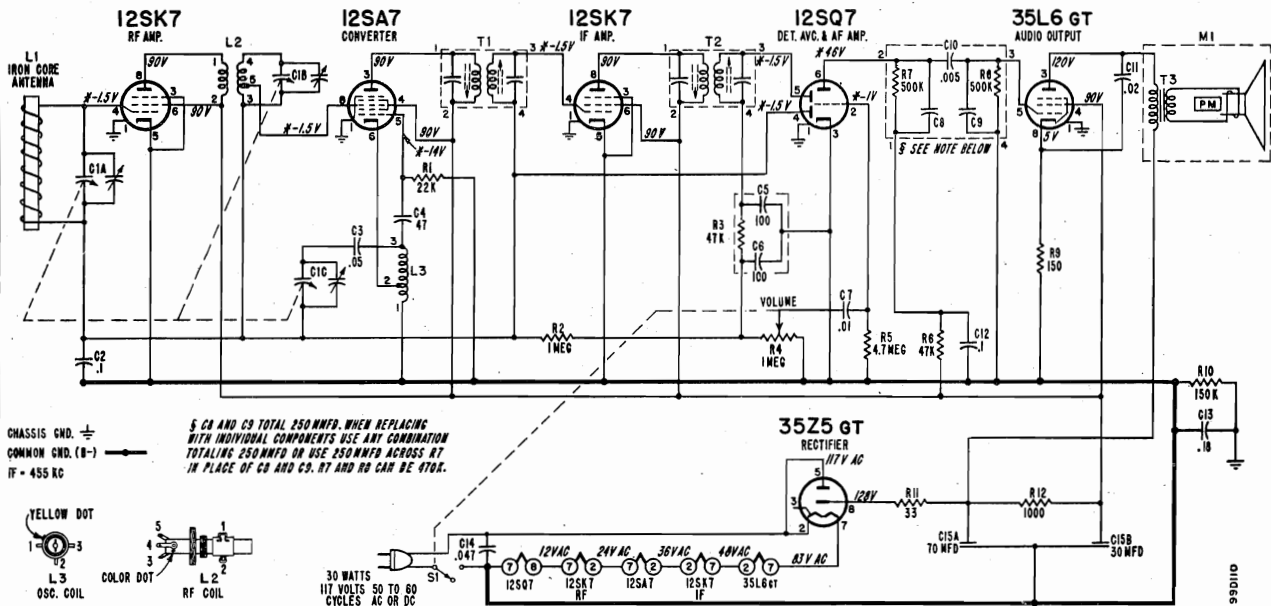

CHASSIS GND. (—)
COMMON GND. (—)
IF - 455 KC

C8 AND C9 TOTAL 250 MFD. WHEN REPLACING WITH INDIVIDUAL COMPONENTS USE ANY COMBINATION TOTALING 250 MFD OR USE 250 MFD ACROSS RT IN PLACE OF C8 AND C9. RT AND R8 CAN BE 470K.

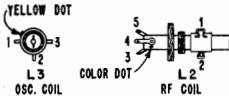

30 WATTS
117 VOLTS 50 TO 60
CYCLES AC OR DC

*These voltage readings will be either lower or practically zero if taken with a 1000 ohms-per-volt meter.

VOLTAGE DATA

Voltages shown on schematic diagram

- All readings made between tube socket terminals and B minus (terminal of On-Off switch).
- Measured on 117 Volt 60 Cycle AC line.
- Volume control minimum; dial turned to low frequency end.
- Voltages measured with Vacuum-tube Voltmeter.

RESISTORS

Symbol	Description	Part No.
R1	22,000 ohms, 1/2 watt	60B 8-223
R2	1 megohm, 1/2 watt	60B 8-105
††R3	47,000 ohms, 1/2 watt	
R4	1 megohm, Volume control and On-Off switch S1	
	for 6C2 chassis	75B 1-48
	for 6C2A chassis	75B 1-56
R5	4.7 megohms, 1/2 watt	60B 8-475
R6	47,000 ohms, 1/2 watt	60B 8-473
†R7	470,000 ohms, 1/2 watt	
†R8	470,000 ohms, 1/2 watt	
R9	150 ohms, 1/2 watt	60B 8-151
R10	150,000 ohms, 1/2 watt	60B 8-154
R11	33 ohms, 1 watt	60B 28-3
R12	1,000 ohms, 1 watt	60B 28-2

CONDENSERS

Symbol	Description	Part No.
C1A	323 mmfd, max Ant.	} gang. 68B 50-1
C1B	193.8 mmfd, max RF	
C1C	90 mmfd, max Osc.	
	(Dial drum spot welded to gang)	
C2	.1 mfd, 200 volts, paper	64B 1-30
C3	.05 mfd, 400 volts, paper	64B 1-22
C4	47 mmfd, mica	65C6-79
††C5	100 mmfd, ceramic	
††C6	100 mmfd, ceramic	
C7	.01 mfd, 400 volts, paper	64B 1-25
†C8	} See Schematic	
†C9		

†Part of couplate (part number 63A 5-4). Replace with exact duplicate or individual components.
Note that numbers 1, 2, 3, 4, on schematic correspond to couplate lead numbers printed on face of couplate 63A 5-4.
††Part of diode filter (part number 63A 3-1). Replace with exact duplicate or individual components.

Symbol	Description	Part No.
†C10	.005 mfd, ceramic	
C11	.02 mfd, 600 volts, paper	64B 1-24
C12	.1 mfd, 200 volts, paper	64B 1-30
C13	.18 mfd, 200 volts, paper	64A 2-2
C14	.047 mfd, 400 volts, paper	65A 13-5
C15A	70 mfd, 150 volts	} elect. 67A 17
C15B	30 mfd, 150 volts	

COILS, TRANSFORMERS, Etc.

Symbol	Description	Part No.
L1	Antenna, Iron Core	69C 148-1
	(mounted on cardboard back)	
L2	Coil, RF	69A 115-1
L3	Coil, Oscillator	69A 52-2
T1	Transformer, 1st I.F.	72B 28-7
T2	Transformer, 2nd I.F.	72B 28-7
T3	Transformer, Output	98A 4
M1	Speaker (5", PM) and Output Transformer	78B 70-1
S1	Switch, On-Off	Part of R4
	Couplate	63A 5-4
	(includes R7, R8, C8, C9, C10)	
	Diode Filter	63A 3-1
	(includes R3, C5, C6)	

MISCELLANEOUS

Description	Part No.
Carton and Fillers	44B 255
Clamp, Line Cord	11A 9-2

Description	Part No.
Clip, IF Transformer Mounting	72B 28-10
Dial Cord (62" length needed)	50A 1-3
Drum, Pointer	A3731
Grommet, Rubber (for mtg. gang)	12A 1-2
Ring, Pointer Compression	19A 31-8
Sleeve, Tuning	
for 6C2 chassis	27A 164
for 6C2A chassis	27A 172-1
Socket, Tube	87A 10-2
Spacer, Metal "T" (for mtg. gang)	29A 2-1-71
Spring, Dial Cord Tension	19C 1-5
Spring, Shaft Retaining	19A 77-1
(for 6C2A chassis)	

CABINET PARTS

Description	Part No.
Back Assembly (includes built-in antenna L1)	69C 148-1
Cabinet, Plastic Mahogany	34D 50-2
Ivory	34D 50-3
Escutcheon Overlay (dial scale)	23C 119-1
Grille Cloth and Baffle Board	AA226
Knob, On-Off Volume	33A 80-2
Knob, Tuning Mahogany	33A 79-2
Ivory	33A 79-3
Pointer, Dial for 6C22, 6C23 Mahogany	25A 53-2
Ivory	25A 53-3
for 622A, 623A Mahogany	A3919
Ivory	A3920
Speed Nut (for mtg. baffle to cabinet)	2B 10-12-69
Stud, Trimount (for mtg. cabinet back)	13A 1-5-68
Washer, Felt (for tuning knobs)	3A 4-4

ALIGNMENT PROCEDURE

- Turn receiver volume control full on.
- Antenna must be connected and placed in the same relative position to the chassis as when in cabinet.
- Use an isolation transformer; otherwise, connect a .1 mfd. capacitor in series with low side of signal generator and connect to chassis. Caution: Do not connect a ground wire directly to chassis.
- Connect output meter across speaker voice coil.
- Use lowest output of signal generator necessary to produce midscale meter indication and proceed in the following sequence.
- Repeat adjustments to insure good results.

Step	Dummy Antenna in Series with Signal Generator	Connection of Signal Generator (High Side)	Signal Generator Frequency	Receiver Gang Setting	Trimmer Description	Trimmer Designation	Type of Adjustment
1	.001 mfd. capacitor	Tuning capacitor, antenna stator	455 KC	Gang fully open	2nd IF 1st IF	*A, B *C, D	Maximum output
2	.001 mfd. capacitor	Tuning capacitor, antenna stator	1620 KC	Gang fully open	Oscillator	E	Maximum output
3	Loop of several turns of wire, or place generator leads close to receiver antenna for adequate signal pickup.	No actual connection (signal by radiation)	1400 KC	Tune in generator signal	Antenna	†F	Maximum output

* Adjustments A and C made from the underside of the chassis. If IF transformers have hollow core slugs, these adjustments may all be made from the top of chassis, if you use alignment tool #98A30-7 obtainable from your Admiral distributor. The bottom IF slug adjustment may be reached through the hollow core in the upper slug. If IF transformers have slotted tuning slugs, use an alignment tool with a blade 3/32" wide.
 † Antenna Trimmer "F" should be aligned after chassis and antenna are mounted in cabinet.

RECORD CHANGER SERVICE DATA

The record changer model number is found stamped at the top rear of the changer pan and on the changer model label.



Models 5D31 Ebony, 5D32 Macoon, 5D33 Ivory

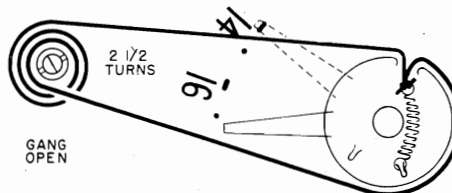

Solid lines show dial stringing and pointer position with tuning gang open. Dashed lines show pointer position (1400KC) when tuning gang is tuned to a generator signal.

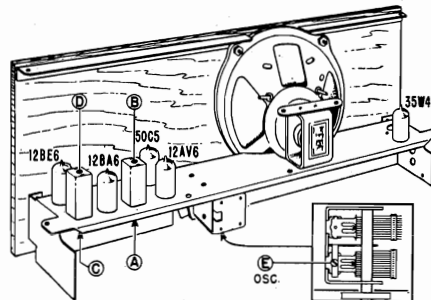

TUBE AND TRIMMER LOCATION

Adjustments A and C made from underside of chassis.
 Adjustment F on antenna.

CARTRIDGE AND NEEDLE

Cartridges complete with needle are interchangeable.

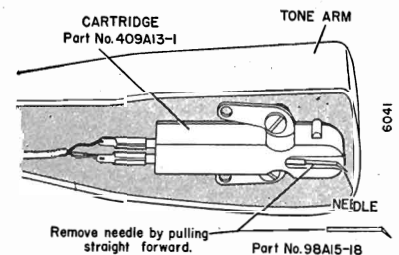
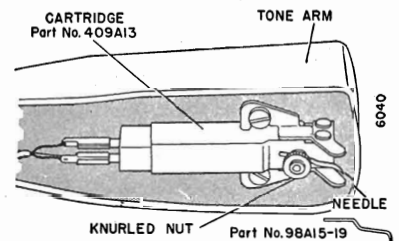
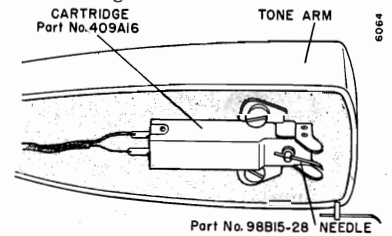

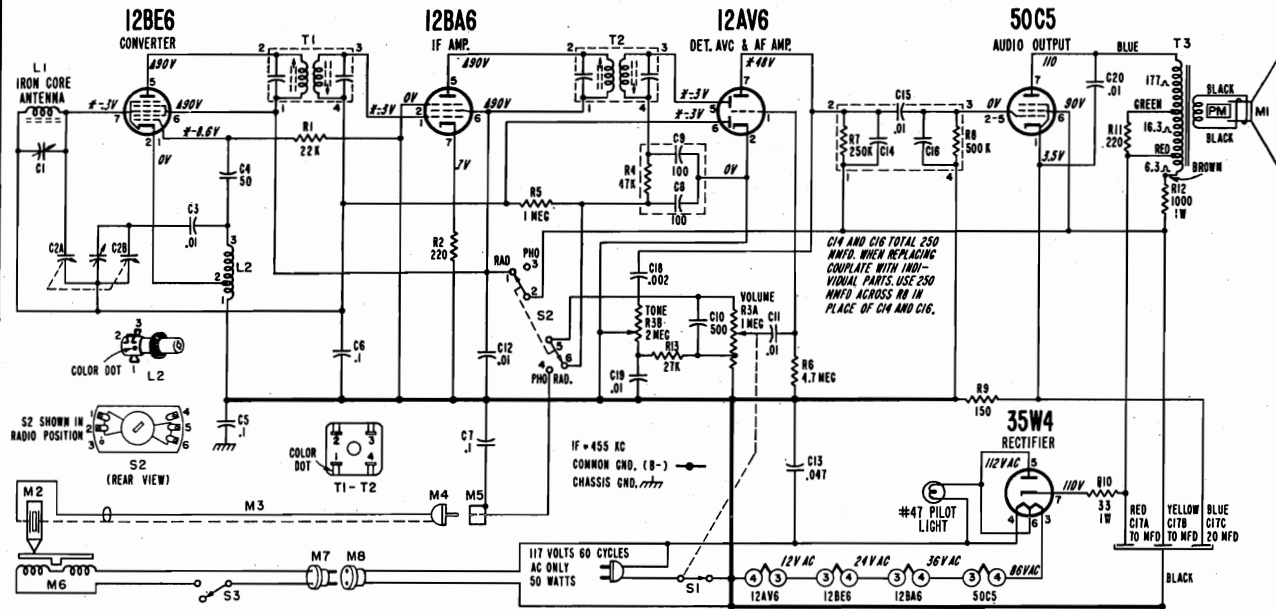

*These readings will be lower if taken with a 1000 ohms-per-volt meter.
 ▲These readings will be zero on "Phono"; other DC readings may be slightly higher.

OPERATING VOLTAGE

117 volts, 60 cycles AC only; 50 watts

VOLTAGE DATA

- All readings made between tube socket terminals and B minus (terminal of On-Off switch).
- Radio-Phono switch S2 in "Radio" position.
- Measured on 117 Volt, 60 Cycle AC line.
- Volume control minimum; dial turned to low end.
- Voltages measured with vacuum-tube voltmeter.

RESISTORS

Symbol	Description	Part No.
R1	22,000 ohms, 1/2 watt	60B 8-223
R2	220 ohms, 1/2 watt	60B 8-221
R3A	1 megohm, Volume	75B 11-8
R3B	2 megohms, Tone	
(Includes switch S1)		
§R4	47,000 ohms, 1/2 watt	
R5	1 megohm, 1/2 watt	60B 8-105
R6	4.7 megohms, 1/2 watt	60B 8-475
†R7	250,000 ohms, 1/2 watt	
†R8	500,000 ohms, 1/2 watt	
R9	150 ohms, 1/2 watt	60B 8-151
R10	33 ohms, 1 watt	60B 28-3
R11	220 ohms, 1/2 watt	60B 8-221
R12	1,000 ohms, 1 watt	60B 28-2
R13	27,000 ohms, 1/2 watt	60B 8-273

CAPACITORS

C1	Trimmer, 3 to 30 mmfd.	66A 33
C2A	Ant. 323mmfd, max.	gang. 68B 55-1
C2B	Osc. 105mmfd, max.	
(Drum spotwelded to gang)		
C3	.01 mfd, 450 volts, ceramic	65C 10-3
C4	50 mmfd, 500 volts, ceramic	65C 6-4
C5	.1 mfd, 200 volts, paper	64B 1-30
C6	.1 mfd, 200 volts, paper	64B 1-30
C7	.1 mfd, 200 volts, paper	64B 1-30
§C8	100 mmfd, ceramic	
§C9	100 mmfd, ceramic	
C10	500 mmfd, ceramic	65C 6-6
C11	.01 mfd, 450 volts, ceramic	65C 10-3
C12	.01 mfd, 450 volts, ceramic	65C 10-3
C13	.047 mfd, 400 volts, paper	65A 13-5
†C14	See schematic	
†C15	.01 mfd, 500 volts, ceramic	
†C16	See schematic	
C17A	70 mfd, 150 volts	
C17B	70 mfd, 150 volts	elect. 67B 7-18
C17C	20 mfd, 25 volts	
C18	.002 mfd, 600 volts, paper	64B 1-14
C19	.01 mfd, 450 volts, ceramic	65C 10-3
C20	.01 mfd, 450 volts, ceramic	65C 10-3

COILS, TRANSFORMERS, ETC.

L1	Antenna, Iron Core (Includes C1)	69B 164
L2	Coil, Oscillator	69A 52-6
*T1	Transformer, 1st IF with hollow core slugs	72C 128-7 with slotted core slugs. 72C 28-7
*T2	Transformer, 2nd IF with hollow core slugs	72C 128-7 with slotted core slugs. 72C 28-7

Symbol	Description	Part No.
T3	Transformer, Output	79C 46-1
M1	Speaker, (6" PM)	78B 81-1
M5	Socket, Phono Input	88A 1
M8	Socket & Leads, Phono Motor	89A 6-3
S1	Switch, On-Off	Part of R3
S2	Switch, Radio-Phono	76B 28-1
	Couplate	63A 5-6
	(Includes R7, R8, C14, C15, C16)	
	Diode Filter	63A 3-1
	(Includes R4, C8, C9)	

MISCELLANEOUS PARTS

Dial Cord (22" length needed)	50A 1-3
Grommet, Rubber (gang mtg.)	12B 1-18
Manual, Customer Instruction	41B 20-31
Manual, Service for RC600	
Record Changer	S454
Pilot Light, #47	81A 1-8
Pointer, Dial (includes compression ring)	A4103
Shaft, Pointer	28A 42
Shield, Pilot Light	82A 4
Sleeve, Tuning (brass)	27A 180
Socket, Pilot Light	82A 20-1
Tube, 7-pin (gang condenser mtg.)	87A 3-4
Spacer, "T" (gang condenser mtg.)	29A 2-1-24
Spring, Dial Cord Tension	19B 1-5
Spring, Hairpin (for tuning sleeve)	19A 2-5

CABINET PARTS

Base, Metal (cabinet legs)	35E 269
Bottom Board	43B 205
Cabinet Bottom, Plastic	
ebony	34E 63-3
maroon	34E 63-5
ivory	34E 63-8
Cabinet Cover, Plastic	
ebony	34E 63-4
maroon	34E 63-6
ivory	34E 63-9
Escutcheon, Dial	23D 140
Escutcheon Ring (gold trim)	23A 53-1
Grille Cloth and Baffle Board	
ebony	A3980
maroon	A3981
ivory	A3982
Hinge	37A 8-1
Hinge Screw (6-32x1/4 BH MS)	365-250-C2-58
Hinge Stud	27A 17-1
Jewel, Pilot Light	82A 21-4

Description	Part No.
Knob, Radio, "Off-Volume" (inner knob)	
ebony	33C 111-7
maroon	33C 111-3
ivory	33C 111-11
"Rad-Pho" (inner knob)	
ebony	33C 111-8
maroon	33C 111-4
ivory	33C 111-12
"Tone" (outer knob)	
ebony	33C 111-5
maroon	33C 111-1
ivory	33C 111-9
"Tuning" (outer knob)	
ebony	33C 111-6
maroon	33C 111-2
ivory	33C 111-10
Nameplate, "Admiral," Plastic	26B 45
Ring, Compression for dial pointer	19A 31-14
for "Off-Volume" knob	19A 31-11
for pilot light jewel	19A 31-15
for "Rad-Pho" knob	19A 31-5
Rubber Channel for cabinet top	12A 9-8
Rubber Foot for cabinet bottom	8A 10
Speed Nut, for mtg. nameplate	2B 12-3-69
Stay Arm and Plate	37A 9-1
Washer, Felt (for tuning knobs)	5A 4-21

PHONOGRAPH PARTS

M2 Cartridge, Pickup (Part nos. 409A 13, 409A 13-1 and 409A 16 used; see illustrations on back page.)	
M3 Cable, Shielded Pickup (includes plug)	413A 11-1
M4 Plug, Pickup Cable	88A 2-3
M6 Motor, Phono (3 speed)	407C 20
M7 Plug, Motor (Male)	88A 8-1
S3 Switch and Mtg. Plate	G400A 606
Adapter, 45 RPM (envelope of 12)	48A 8-2
Button, Snap-in Plug	13A 2-8-57
Centerpost Assembly	G400B 601
Idler Wheel (includes tire)	G400A 279
Kit, 50 Cycle Conversion	98B 15-24
Manual, Service	S454
Needle, Pickup for 409A13 cartridge	98A 15-19
for 409A13-1 cartridge	98A 15-18
for 409A 16 cartridge	98B 15-28
Needle Retaining Nut (for 409A13 cartridge)	98A 54-2
Screw and Washer, Changer Mounting (10-32x1/4 RH MS)	AA210
Spring, Changer Float	19A 10-3

*Transformers differ slightly. For best results, order exact part.
 §Part of Diode Filter, part number 63A 3-1. This unit consisting of C8, C9 and R4 may be replaced with individual components.
 †Part of couplate, part number 63A 5-6. See schematic.

MODELS 5E31, 5E32, 5E33, Ch. 5E3

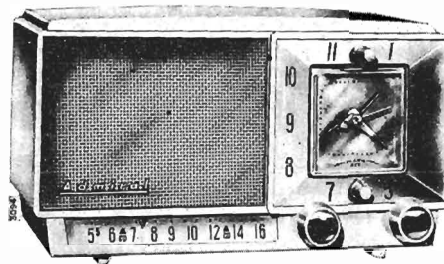

Model 5E31 Ebony, 5E32 Maroon, 5E33 Ivory, 5E38 Green, 5E39 Gray.

ALIGNMENT PROCEDURE

- Turn receiver volume control full on (fully clockwise).
 - Use an isolation transformer if available; otherwise, connect a .1 mfd. capacitor in series with low side of signal generator and connect to chassis.
 - Connect output meter across speaker voice coil.
 - Use lowest output of signal generator required for midscale meter indication and proceed in the following sequence.
 - Repeat adjustments to insure good results.
- Caution: Do not connect a ground wire directly to chassis.

Step	Dummy Antenna in Series with Signal Generator	Connection of Signal Generator (High Side)	Signal Generator Frequency	Receiver Gang Setting	Trimmer Description	Trimmer Designation	Type of Adjustment
1	250 mmfd. condenser	Antenna stator of tuning capacitor	455 KC	Gang fully open	2nd IF 1st IF	*A, B, *C, D	Maximum output
2	250 mmfd. condenser	Antenna stator of tuning capacitor	1620 KC	Gang fully open	Oscillator	E	Maximum output
Set tuning pointer with tuning gang tuned to 1400 KC generator signal; see illustration below.							
3	Loop of several turns of wire, or place generator lead close to receiver loop for adequate signal pickup.	No actual connection (signal by radiation)	1400 KC	Tune in generator signal	Antenna	F	Maximum output

*Adjustments A and C made from the underside of the chassis. If IF transformers have hollow core slugs, these adjustments may be made from the top of the chassis, if you use alignment tool #98A30-7 obtainable from your Admiral distributor. The bottom IF slug adjustment may be reached through the hollow core in the upper slug. If IF transformers have slotted head tuning slugs, use an alignment tool with a blade 3/32" wide.

TUBE AND TRIMMER LOCATION

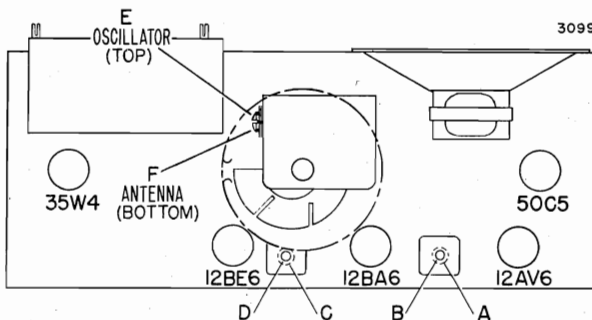

Adjustments A and C made from underside of chassis.

OPERATING RADIO MANUALLY

When the "Auto-Off-On" switch is set to the "On" position, the radio may be operated manually with the "Off-Volume" knob. The On-Off switch in the radio will not control the clock or the appliance outlet.

TO REMOVE CLOCK FROM CABINET

- To remove the clock, proceed as follows:
1. Remove the radio chassis from the cabinet.
 2. Remove four Phillips screws which mount the clock to the cabinet.
 3. Carefully remove the clock. Do not unsolder electrical connections unless complete removal of the clock is required.

DIAL STRINGING AND POINTER SETTING

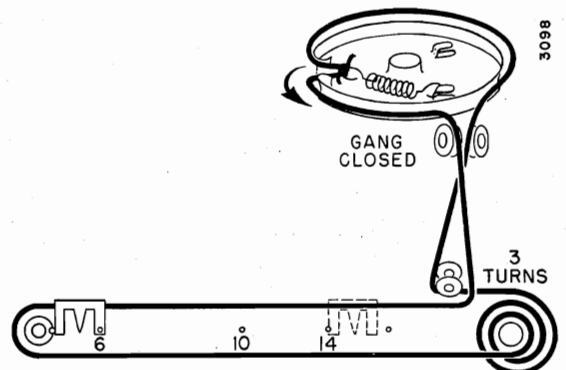

Dial stringing and pointer with solid lines shown with gang closed. Dashed line pointer position (1400 KC) shown when tuning gang is tuned to generator signal.

PARTS AND SERVICE FOR CLOCK

Consult your Admiral distributor for the address of the nearest parts and service station for clocks used in Admiral radios.

5528

MODELS 5E31, 5E32, 5E33, Ch. 5E3

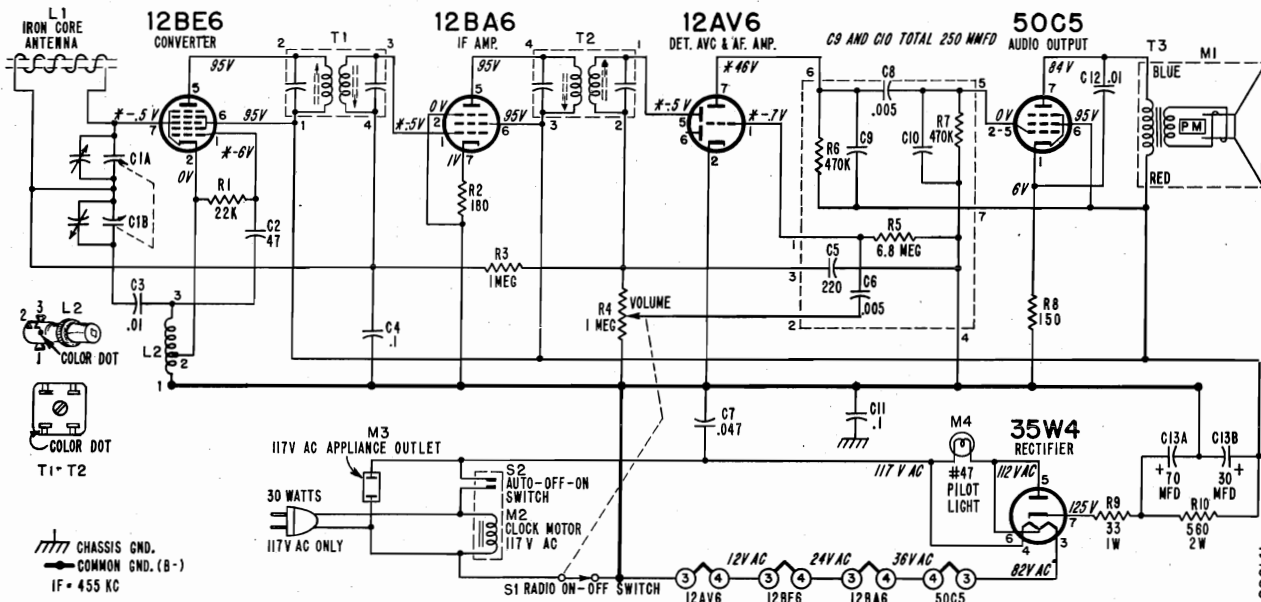

*These voltage readings will be either lower or practically zero if taken with a 1000 ohms-per-volt meter.

VOLTAGE DATA

- Voltages shown on schematic diagram.
- All readings made between tube socket terminals and B minus (terminal of On-Off switch).
- Measured on 117 Volt AC line.
- Volume control minimum; dial set at low frequency end.
- Voltages measured with vacuum-tube voltmeter.

RESISTORS

Symbol	Description	Part No.
R1	22,000 ohms, 1/2 watt	60B 8-223
R2	180 ohms, 1/2 watt	60B 8-181
R3	1 megohm, 1/2 watt	60B 8-105
R4	1 megohm, Volume control (R4 includes switch S1)	75B 1-58
R5	6.8 megohms, 1/4 watt	60B 8-151
R6	470,000 ohms, 1/4 watt	60B 28-3
R7	470,000 ohms, 1/4 watt	60B 28-3
R8	150 ohms, 1/2 watt	60B 8-151
R9	33 ohms, 1 watt	60B 28-3
R10	560 ohms, 2 watts	60B 20-561

CAPACITORS

C1A	290 mmfd, max. Ant. (Dial drum spotwelded to gang)	68B 51-1
C1B	104 mmfd, max. Osc.	68B 51-1
C2	47 mmfd, ceramic	65C 6-79
C3	.01 mfd, ceramic	65C 10-3
C4	.1 mfd, 200 volts, paper	64B 1-30
C5	220 mmfd, ceramic	65C 10-3
C6	.005 mfd, ceramic	65C 10-3
C7	.047 mfd, 400 volts, paper	65A 13-5
C8	.005 mfd, ceramic	65C 10-3
C9	see note on schematic	
C10	.1 mfd, 200 volts, paper	64B 1-30
C11	.01 mfd, ceramic	65C 10-3
C12	.01 mfd, ceramic	65C 10-3
C13A	70 mfd, 150 volts	67A 17-1
C13B	30 mfd, 150 volts	67A 17-1

COILS, TRANSFORMERS, ETC.

L1	Iron Core Antenna and Cabinet Back	69B 171
----	------------------------------------	---------

MISCELLANEOUS PARTS

Symbol	Description	Part No.
L2	Coil, Oscillator	69A 52-7
*T1	Transformer, 1st IF with hollow core slugs.72C 128-7 with slotted core slugs.72C 28-7	72C 128-7
*T2	Transformer, 2nd IF with hollow core slugs.72C 128-7 with slotted core slugs.72C 28-7	72C 28-7
T3	Transformer, Output	98A 21
M1	Speaker (4" PM) and Output Transformer	78B 85
M3	Outlet, Appliance	87A 21-1
M4	Socket, Pilot Light	82A 17-4
S1	Switch, Radio On-Off	Part of R4
S2	Switch Auto-On-Off	Part of M2
	Couplate (Includes R5, R6, R7, C5, C6, C8, C9, C10)	63B 6-7
	Bracket, Pointer Support	15A 936
	Clip, IF Transformer Mounting	72B 28-10
	Drum, Dial Pointer	17A 5-2
	Grommet, Rubber (gang mtg.)	12B 1-18
	Line Cord and Plug	89A 34-1
	Manual, Customer Instructions	41B 20-32
	Pilot Light, #47	81A 1-8
	Pointer, Dial	25A 57
	Shaft, Tuning	28A 70-1
	Socket, Tube	87A 3-4
	Spacer, Metal "T" (for mtg. gang)	29A 2-3-24
	Speed Nut (mtg. pointer shaft sleeve)	2B 10-28-59
	Spring, Dial Cord Tension	19C 1-5
	Washer, "E" (for tuning shaft)	4B 12-4

CABINET PARTS

Description	Part No.
Cabinet, Plastic	
ebony	34D 67-1
maroon	34D 67-2
ivory	34D 67-3
green	34D 67-4
gray	34D 67-5
Grille, Metal	36B 46
Knobs, Tuning and Volume	
ebony	33A 81-1
maroon	33A 81-2
ivory	33A 81-3
green	33A 81-4
gray	33A 81-5
Nameplate, "Admiral"	26A 44
Pointer, Tuning	25A 57
Trimount Fastener (for cabinet back)	13A 1-5
Washer, Felt (for tuning knobs)	5A 4-19

CLOCK PARTS

M2 Clock, Complete for 117 volts, 60 cycles	91C 9-1
Knob, Clock	
ebony	91C 9-11
maroon	91C 9-12
ivory	91C 9-13
green	91C 9-14
gray	91C 9-15
Window (plastic)	24A 13

§Part of couplate (part No. 63B 6-7). Numbers on schematic correspond to lead numbers on couplate.
*Transformers differ slightly. For best results, order exact part.

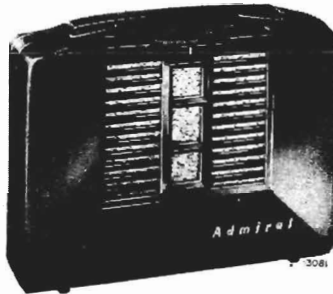

Models 4X11 Ebony, 4X12 Maroon,
4X18 Green and 4X14 Gray

GENERAL

This receiver incorporates the latest radio circuitry with printed circuit technique. The printed circuit used in this receiver replaces the hookup wire used in earlier receivers. See figures 1 and 2. The printed circuit is permanently fixed to the plastic chassis base by a photoengraving process. This new method of circuitry offers uniform chassis wiring, fewer wiring troubles and simplifies circuit tracing and trouble shooting. All circuit components are standard size and design. For servicing convenience, all parts are mounted on the top of the chassis; see figure 2. Audio circuit parts are contained in a printed circuit couplate, part number 63B6-6.

In general, trouble shooting and parts replacement will be the same as for receivers wired with hookup wire. However, when servicing, it is important to read the service information given in this manual concerning servicing technique for printed circuit receivers. A top view of the chassis is shown in figure 2. A bottom view of the chassis is shown in figure 1.

REPLACING PARTS

To avoid damaging printed circuits with excessive heat, use a soldering iron (60 watts maximum) with a small tip when replacing parts.

To remove defective parts, apply the tip of the soldering iron to the connection at the underside of the chassis. Keep soldering iron on connection just long enough to melt the solder, then quickly tap the chassis against the service bench to shake the solder away from the connection. After the solder is removed, untwist or separate connections. A pick will be helpful for untwisting or separating connections. After disconnecting wires or lugs, carefully remove parts from the top of the chassis.

SPECIFICATIONS

Circuit: Superheterodyne using 4 miniature tubes. See additional circuit information

Frequency Range: Standard broadcast band, 535 to 1620 KC.

Intermediate Frequency: 455 KC.

Power Supply: Two 1½ volt "A" batteries and one 67½ volt battery.

Antenna: Built-in Ferro-Scope (iron-core) antenna.

Speaker: 3½" PM, with Alnico V magnet. Voice coil impedance, 3.2 ohms.

Before installing replacement parts, clean the solder from the connection, so the wires or lugs may pass through the holes in the chassis panel. To avoid running solder into adjoining circuits, use as little solder as necessary.

For quick replacement, resistors and capacitors may be replaced by clipping out the defective part and soldering the new part to the connecting wires remaining from the original part.

An open or damaged section of the printed circuit can be repaired by soldering a jumper of ordinary hookup wire across the connection points. To avoid need for complete tube socket replacement, defective tube socket terminals may be replaced individually. Tube socket terminals are available under part number 87A35-2.

Note: The tubular shield (center connection) at the bottom of each tube socket must be securely soldered to the printed circuit, otherwise hum or oscillation will result.

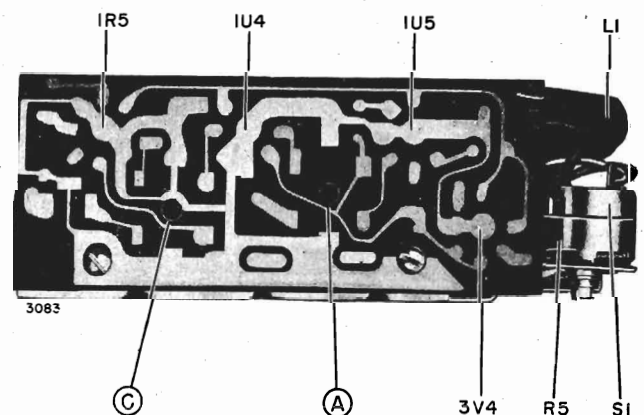

Figure 1. Bottom View of Chassis.

ALIGNMENT PROCEDURE

- Use FRESH batteries when alignment adjustments are made.
- Connect output meter across speaker voice coil.
- Turn receiver volume control full on.
- Use lowest output of signal generator necessary for producing adequate output meter indication and then proceed as outlined in chart below.
- Use a NON-METALLIC alignment tool for IF transformers.
- Repeat adjustments to insure good alignment.

Step	Dummy Antenna in Series with Signal Generator	Connection of Signal Generator (High Side)	Signal Generator Frequency	Receiver Gang Setting	Trimmer Description	Trimmer Designation	Type of Adjustment
1	.1 mfd. capacitor	Stator of antenna tuning capacitor	455 KC	Gang fully open	2nd IF 1st IF	*A, B *C, D	Maximum Output
2	.1 mfd. capacitor	Stator of antenna tuning capacitor	1620 KC	Gang fully open	Oscillator (on gang)	E	Maximum Output
3	Loop of several turns of wire or place generator lead close to receiver loop for adequate signal pickup.	No actual connection (signal by radiation)	1400 KC	Tune in generator signal	Antenna (on gang)	F	Maximum Output

*Adjustments A and C made from the underside of the chassis. To avoid splitting the slotted head of powdered iron core tuning slugs in IF transformers, use an alignment tool with a blade 3/32" wide.

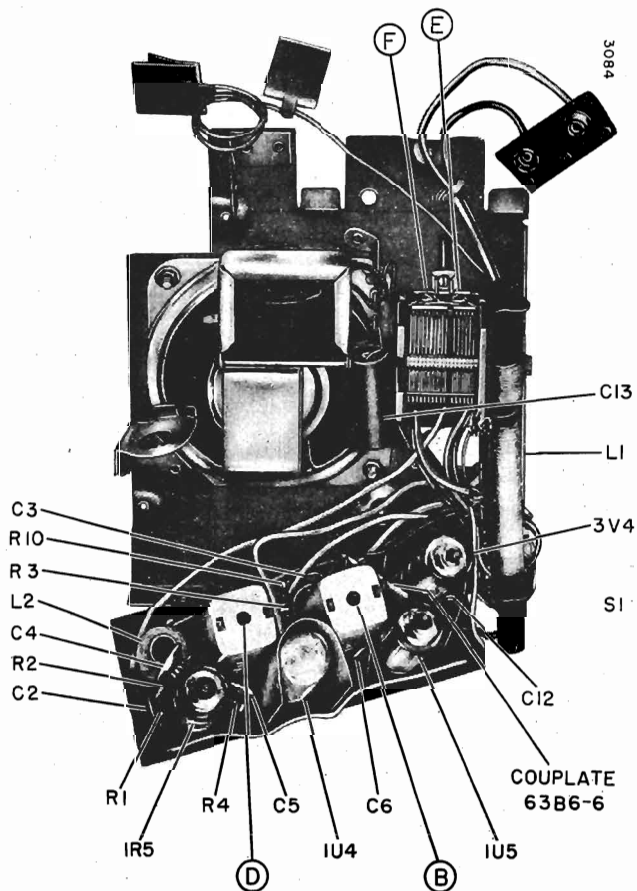
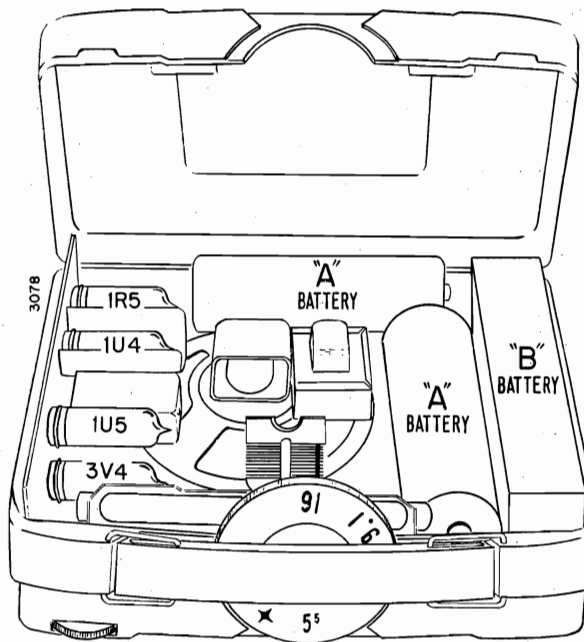

Figure 2. Top View of Chassis. Location of Components and Alignment Adjustments Shown. Adjustments A and C made from underside. See figure 1.



REPLACING BATTERIES

In normal use, batteries for this set should furnish about 80 operating hours. Batteries of the type given below, or an equivalent substitute may be used in this set.

"A" Battery (1½ volts) : R.C.A. VS236, Burgess 21R, Eveready 964.

"B" Battery (67½ volts) : R.C.A. VS216, Burgess P45, Eveready 477.

CAUTION

To avoid damage to test equipment or to the printed circuit, do not place the chassis directly on a metal service bench, tools or other metal objects.

When making voltage or resistance measurements, use test leads with needle point prods to avoid short circuits between sections of the printed circuit wiring.

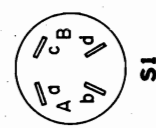
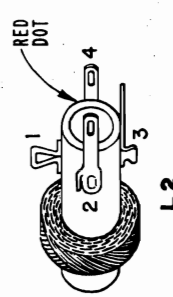
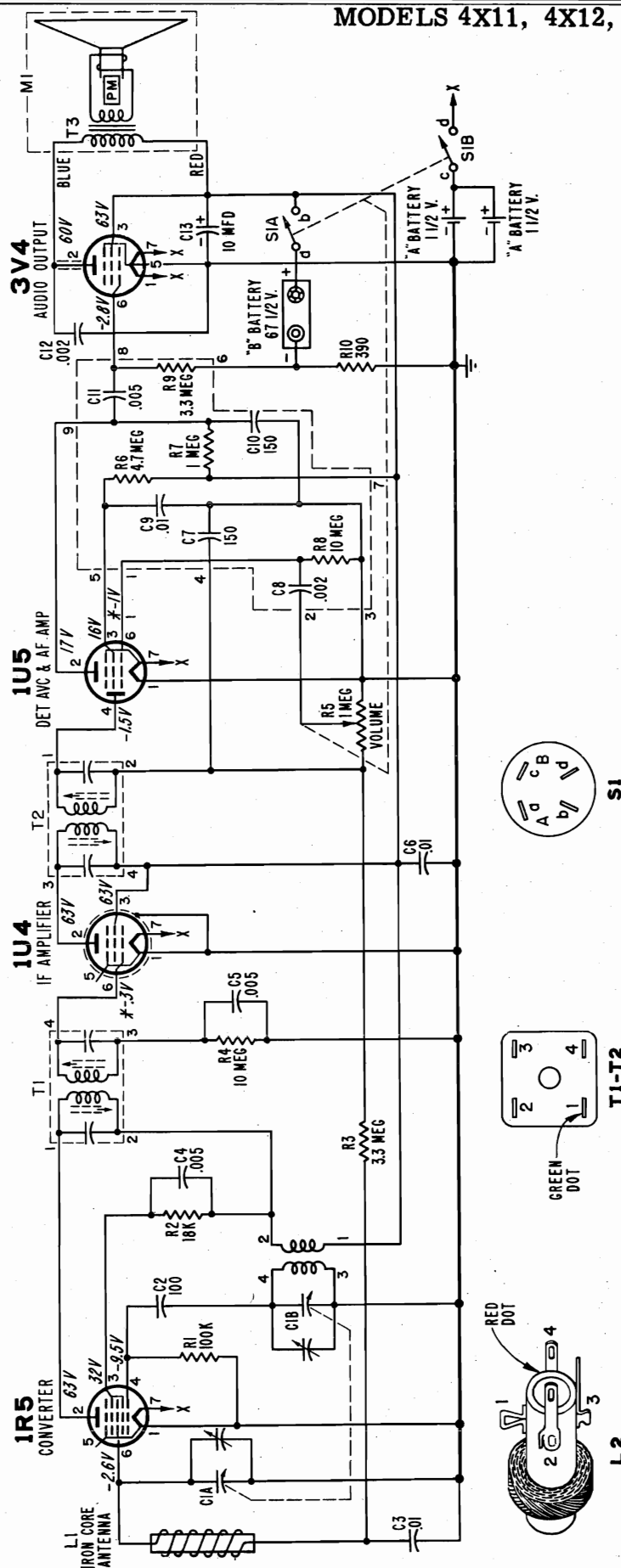

*These voltage readings will be either lower or practically zero if taken with a 1000 ohms-per-volt meter.

VOLTAGE DATA

- All readings made between tube socket terminals and chassis
- Dial turned to low frequency end; volume control at minimum.
- Voltages measured with fresh batteries.
- Voltages measured with Vacuum-tube Voltmeter.

MODELS 4X11, 4X12, 4X18, 4X19, Ch. 4X1

RESISTORS

Symbol	Description	Part No.
R1	100,000 ohms, 1/2 watt.....	60B 8-104
R2	18,000 ohms, 1/2 watt.....	60B 8-183
R3	3.3 megohms, 1/2 watt.....	60B 8-335
R4	10 megohms, 1/2 watt.....	60B 8-106
R5	1 megohm, Volume control.....	75B 19-1 (includes switch S1)
†R6	4.7 megohms	
†R7	1 megohm	
†R8	10 megohms	
†R9	3.3 megohms	
R10	390 ohms, 1/2 watt.....	60B 8-391

CAPACITORS

Symbol	Description	Part No.
C1A	197 mmfd, max, ant. } gang.	68B 56
C1B	97.8 mmfd, max, osc. }	
C2	100 mmfd, ceramic.....	65C 6-3
C3	.01 mfd, ceramic.....	65A 10-3
C4	.005 mfd, ceramic.....	65A 10-5
C5	.005 mfd, ceramic.....	65A 10-5
C6	.01 mfd, ceramic.....	65A 10-3
†C7	150 mmfd	
†C8	.002 mfd	
†C9	.01 mfd	
†C10	150 mmfd	
†C11	.005 mfd	
C12	.002 mfd, ceramic.....	65B 9-37
C13	10 mfd, 75 volts, electrolytic	67A 4-11

COILS, TRANSFORMERS, ETC.

Symbol	Description	Part No.
L1	Antenna, Iron Core.....	69B 166-1
L2	Coil, Oscillator.....	69A 165-1
T1	Transformer, 1st IF.....	72B 28-64
T2	Transformer, 2nd IF.....	72B 28-64
T3	Transformer, Output.....	98A 21
M1	Speaker (3 1/2" PM) and Output Transformer.....	78B 83-1
S1	Switch, On-Off.....	Part of R5
	Couplate.....	63B 6-6 (includes R6, R7, R8, R9 C7, C8, C9, C10, C11)

MISCELLANEOUS PARTS

Description	Part No.
Bracket	
"A" Battery Ground.....	18A 70
"A" Battery Ground.....	18A 74
Carton and Fillers.....	44C 288
Clip, Fuse (for cabinet catch).....	84A 10-16
Connector	
"A" Battery.....	18A 72
"B" Battery.....	90A 6-1
Nut (for mtg. speaker).....	2A 1-14-24
Lockwasher (for mtg. speaker).....	3B 1-26-24

Description	Part No.
Screw	
for mtg. antenna, #6-32 x 1/8	
BH MS.....	265-125-C2-24
for mtg. fuse clip, #4-40 x 3/16	
RH MS.....	40-187-C2-24
for mtg. gang, #6-32 x 3/16	
BH MS.....	265-187-C2-24
for mtg. chassis base, #6-32 x 1/4	
RH MS.....	260-250-C2-24
for mtg. speaker, #8-32 x 5/16	
BH MS.....	85-312-C2-70
Socket, Tube.....	87A 35-1
Terminal, Tube Socket.....	87A 35-2
Terminal Lug.....	9B 1-3

CABINET PARTS

Description	Part No.
Bracket, Handle Support.....	19A 76
Cabinet, Front (includes grille)	
ebony.....	34D 64-1
maroon.....	34D 64-3
green.....	34C 64-5
gray.....	34D 64-7
Cabinet, Rear	
ebony.....	34D 64-2
maroon.....	34D 64-4
green.....	34D 64-6
gray.....	34D 64-8
Compression Ring (for tuning knob).....	19A 31-10
Eyelet (for cabinet catch).....	6B 3-31
Grille Cloth and Baffle.....	AA 227-7
Handle, Plastic	
ebony.....	37B 87-1
maroon.....	37B 87-2
green.....	37B 87-3
gray.....	37B 87-4
Hinge, Spring.....	19A 72-1
Knob, Tuning	
ebony.....	33B 104-1
maroon.....	33B 104-3
green.....	33B 104-5
gray.....	33B 104-7
Knob, Volume	
ebony.....	33B 104-2
maroon.....	33B 104-4
green.....	33B 104-6
gray.....	33B 104-8
Screw	
for mtg. chassis, #4-40 x 3/16	
BH MS.....	245-187-C2-24
for mtg. eyelet, #6-32 x 3/8	
BH MS.....	60-375-C2-24
for mtg. Volume knob, #4-40 x 5/16	
BH MS.....	245-312-C2-24

†Part of couplate, part number 63B 6-6. Numbers on schematic correspond to lead numbers on couplate.



Models 4Y11 Ebony, 4Y12 Maroon,
4Y18 Green and 4Y19 Gray

SPECIFICATIONS

Circuit: Superheterodyne receiver with 4 miniature tubes and a selenium rectifier.

Frequency Range: Standard broadcast band, 535 to 1620 KC.

Intermediate Frequency: 455 KC.

Power Supply: This receiver will operate on 117 volt AC or DC or on one 67½ volt "B" battery and one 7½ volt "A" battery.

Power Consumption: 20 watts on 117 volt AC or DC line.

Antenna: Built-in Ferro-Scope (iron core) antenna.

Speaker: 3½" PM, with Alnico V magnet. Voice coil impedance, 3.2 ohms.

REPLACING BATTERIES

Note: Run-down batteries should be removed from the set. Corrosive material may leak from a run-down battery and parts of the chassis or the cabinet are likely to be damaged.

In normal use, batteries for this set should furnish about 40 operating hours. Batteries listed below, or an equivalent substitute may be used in this set.

"A" Battery (7½ volts): Burgess C5, Eveready 717 or equivalent.

"B" Battery (67½ volts): Burgess XX45, Eveready 467 or equivalent.

REPLACING TUBES

Any tube may be removed or replaced after the knurled knobs are pulled off the tuning and volume control shafts. Some type of tube extracting device may be useful, or a tube may be removed by carefully working a slender screwdriver between the base of the tube and its socket.

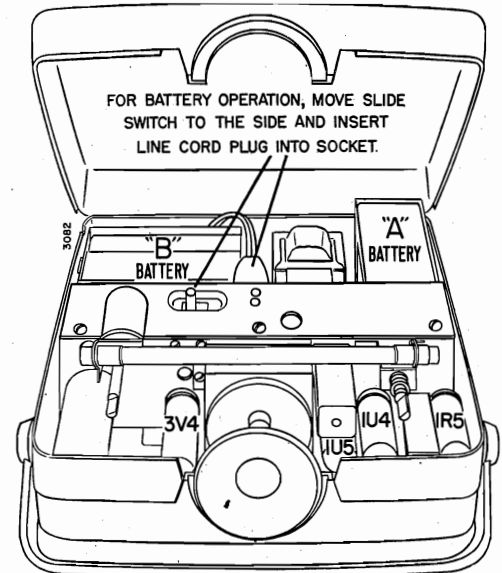

Tube and Battery Location

REMOVING THE CHASSIS

The chassis need only be removed from the cabinet when servicing the underside of the chassis.

To remove the chassis, proceed as follows:

- Remove one screw from the chassis to disconnect the head chain fastened to the cabinet.
- Remove and disconnect the "A" and "B" batteries; remove the knurled tuning knob and the 1U4 tube.
- Remove the chassis mounting screw located in each battery case and behind the tubes. The entire chassis may be lifted out of the cabinet.

The chassis cover must be removed to align the re-

ALIGNMENT PROCEDURE

- Battery power is preferable for alignment; use FRESH batteries. If this set is to be aligned while operating on an AC power line, an isolation transformer should be used. If an isolation transformer is not available, connect a .1 mfd. capacitor in series with the signal generator low side to B minus (pin 7 of 1U5 tube.)
- The chassis cover must be removed to align trimmers A and C.
- Set volume control full on.
- Connect output meter across speaker voice coil.
- Use lowest setting of signal generator capable of producing adequate output meter indication.
- Use a non-metallic alignment tool for IF transformers.
- Repeat adjustments to insure good results.

Step	Dummy Antenna in Series with Signal Generator	Connection of Signal Generator (High Side)	Signal Generator Frequency	Receiver Gang Setting	Trimmer Description	Trimmer Designation	Type of Adjustment
1	.001 mfd. when using AC. .1 mfd. when using Battery.	Stator of antenna tuning capacitor	455 KC	Gang fully open	2nd IF 1st IF	*A, B *C, D	Maximum output
2	.001 mfd. when using AC. .1 mfd. when using Battery.	Stator of antenna tuning capacitor	1620 KC	Gang fully open	Oscillator (on gang)	E	Maximum output

Install the metal chassis cover removed during IF Alignment.

3	Loop of several turns of wire, or place generator lead close to receiver for adequate signal pickup.	No actual connection (signal by radiation)	1400 KC	Tune in generator signal.	Antenna (on gang)	F	Maximum output
---	--	--	---------	---------------------------	-------------------	---	----------------

*Adjustments A and C are made from underside of chassis. To avoid splitting the slotted head of powdered iron tuning slug in IF transformers, use an alignment tool with a blade 3/32" wide.

ceiver or check voltages, etc. Remove the remaining two screws which hold the cover on the chassis. Press the switch button to disengage the chassis cover.

When replacing the chassis cover, press the switch button to permit the cover to fit on the chassis at all points. Three tabs on the chassis cover must fit in slots along the edge of the chassis at either side of the speaker. Caution: Be sure the lead wires from the output transformer (on the speaker) are not caught between the chassis and the cover.

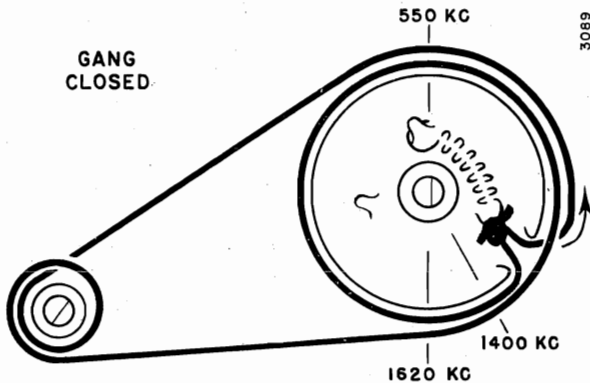

Dial Cord Stringing

DIAL CORD STRINGING

To string the dial cord, close the tuning gang. Start stringing at the tension spring and run the dial cord in the direction indicated by the arrow. See illustration below. Draw the dial cord tight to apply tension on the spring and prevent slipping at the tuning shaft.

TUBE AND TRIMMER LOCATION

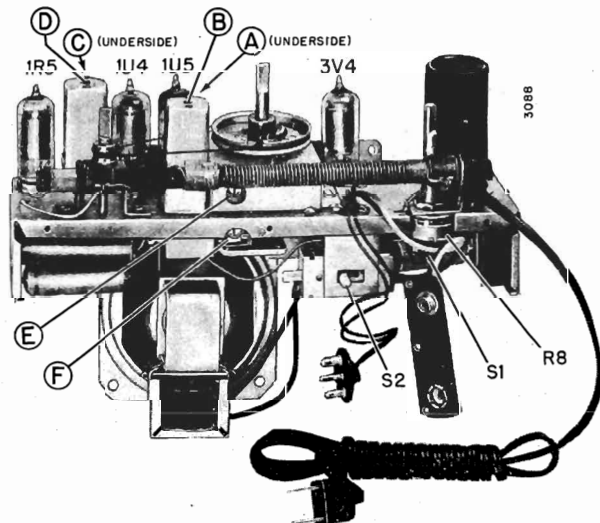

Adjustments A and C are made from underside of chassis.

RESISTORS

Symbol	Description	Part No.
R1	2.2 megohms, 1/2 watt	60B 8-225
R2	100,000 ohms, 1/2 watt	60B 8-104
R3	270 ohms, 1/2 watt	60B 8-271
R4	18,000 ohms, 1/2 watt	60B 8-183
R5	10 megohms, 1/2 watt	60B 8-106
R6	390 ohms, 1/2 watt	60B 8-391
R7	3.3 megohms, 1/2 watt	60B 8-335
R8	1 megohm, Volume control. 75C 1-57 (Includes On-Off switch S1)	
R9	120 ohms, 1/2 watt	60B 8-121
†R10	10 megohms, 1/2 watt	
†R11	4.7 megohms, 1/2 watt	
†R12	1 megohm, 1/2 watt	
†R13	3.3 megohms, 1/2 watt	
R14	2,200 ohms, 1/2 watt	60B 8-222
R15	47 ohms, 1 watt	60B 14-470
R16	2,700 ohms, 1 watt	60B 14-272
R17A	1380 ohms } 5 watt tapped	
R17B	1380 ohms } Candohm	61A 5-7

CAPACITORS

Symbol	Description	Part No.
C1A	272 mmfd, max. Ant. } gang.	68B 57
C1B	107 mmfd, max. Osc. }	
C2	250 mmfd, ceramic	65C 6-5
C3	.25 mfd, 200 volts, paper	64B 1-28
C4	.005 mfd, ceramic	65C 10-5
C5	100 mmfd, ceramic	65C 6-3
C6	.18 mfd, 200 volts, paper	64A 2-2
C7	.01 mfd, 400 volts, paper	64B 1-25
C8	.001 mfd, ceramic	65C 6-41
C9	100 mfd, 25 volts, electrolytic	67A 4-6
†C10	.01 mfd, ceramic	
†C11	150 mmfd, ceramic	
†C12	.002 mfd, ceramic	
†C13	150 mmfd, ceramic	
†C14	.005 mfd, ceramic	
C15	.001 mfd, ceramic	65C 6-41
C16	.047 mfd, 400 volts, paper	65A 13-5
C17A	20 mfd, 150 volts } elect.	67C 7-41
C17B	30 mfd, 150 volts }	
C17C	20 mfd, 150 volts }	

COILS, TRANSFORMERS, ETC.

Symbol	Description	Part No.
L1	Antenna, Iron Core	69B 167-1
L2	Coil, Oscillator	69A 39-7
T1	Transformer, 1st IF	72B 28-1
T2	Transformer, 2nd IF	72B 28-62
T3	Transformer, Output	98A 21
M1	Speaker (3 1/2" PM) and Output Trans.	78B 58-2
M2	Rectifier, Selenium	93A 1-4
S1	Switch, On-Off	Part of R8
S2	Switch, Power Change	77A 46
	Couplate (includes R10, R11, R12, R13, C10, C11, C12, C13, C14)	63B 6-6

MISCELLANEOUS PARTS

Description	Part No.
Bracket, Antenna Support (Includes fiber insulator support)	A3911
Chassis Cover (Includes "A" and "B" battery cases)	A3904
Clip, IF Transformer Mounting	72B 28-10
Connector	
"A" Battery	90A 7-1
"B" Battery	90A 5-3
Dial Cord (13" length needed)	50A 1-3
Drum, Tuning, and Hub	A3906
Insulator, Fiber (for mtg. rectifier)	32A 137
Insulator Support, Fiber (for mtg. ant.)	32A 195

Description	Part No.
Line Cord Clamp	11A 9-2
Plate, Fiber (for mtg. Electrolytic)	67A 2-1
Retainer, Fiber (for "B" Battery)	32A 191
Screw	
for mtg. chassis cover (#6-32 x 1/4 S.T.)	1A 52-10-24
for mtg. speaker (#6-32 x 1/4 B.H.M.S.)	265-250-C2-24
for mtg. tuning drum (#6-32 x 1/8 Allen Set)	1A 43-7
Shaft, Tuning	28A 69
Socket, Tube	87A 3-7
Spring, Dial Cord	19C 1-5
Washer	
"C", for mtg. tuning shaft	4A 4-5
for mtg. tuning shaft	4A 6-13

CABINET PARTS

Description	Part No.
Button, Handle Ornament	20A 18
Cabinet, Front	
ebony	34E 65-1
maroon	34E 65-3
green	34E 65-5
gray	34E 65-7
Cabinet, Rear	
ebony	34E 65-2
maroon	34E 65-4
green	34E 65-6
gray	34E 65-8
Carton and Fillers	44C 287
Chain, Bead	31A 1-2
Clip, for mtg. baffle	15A 922
Fuse, for cabinet catch	84A 10-16
Latch, for cabinet catch	18A 80
Eyelet, for mtg. fuse clip	6B 3-43
Grille Cloth and Baffle	AA227-8
Grille, Metal	36B 44
Grille Trim, Metal for front and rear of cabinet	23C 147
Handle, Plastic Covered	
ebony	A4127
maroon	A4128
green	A4129
gray	A4130
Hinge, Spring	19A 72-1
Knob, Dial	
ebony	33C 105-1
maroon	33C 105-4
green	33C 105-7
gray	33C 105-10
Knob, Tuning	
ebony	33C 105-2
maroon	33C 105-5
green	33C 105-8
gray	33C 105-11
Knob, Volume	
ebony	33C 105-3
maroon	33C 105-6
green	33C 105-9
gray	33C 105-12
Ring, Compression, for knobs	19A 31-10
Screw, for mtg. chassis (#6-32 x 5/16 R.H.M.S.)	260-312-C2-24
for mtg. baffle (#4-24 x 1/4 B.H.S.T.)	1A 27-1-24
Tubing, Plastic, for bead chain (5/16" dia. x 4 1/2 long)	96B 19-2
Washer, "E", for mtg. handle (3/16" size)	4B 12-23
Flat, for mtg. handle (.196 x 3/8 x 1/32)	4B 1-68-24
Flat, for mtg. handle (.196 x 3/4 x 1/32)	4B 2-74
Spring, for mtg. handle (3/16 x 3/8 x 5/64)	4A 5-19

†Part of couplate, part of number 63B 6-6. Numbers on schematic correspond to lead numbers on couplate.

MANUFACTURER	MANUFACTURER'S TYPE NUMBER
"A" Battery	"B" Battery
National Carbon (Eveready)	746 490
General Dry Battery	3H3 132
Ray-O-Vac	P83A 4390
Burgess Battery	G3 N-60

BATTERY OPERATION

BATTERY OPERATION: To operate this receiver on battery, insert the power cord prongs into the power switch through the two slots provided in the bottom of chassis. These slots are at the right hand edge of chassis as viewed from rear.

TUBE REPLACEMENT

Do not replace tubes or batteries unless switch on the volume control is turned completely off. In case of tube failure be sure to turn the receiver off immediately.

Four tubes (Plus selenium rectifier) are used. Type numbers and locations are shown in the tube diagram label located inside the cabinet. If tubes are removed from their sockets for test or replacement purposes, make certain that the receiver is turned off when replacing the tubes in their proper sockets. Failure to replace tubes in their proper sockets may result in damage to the tube, or to the receiver, or both.

SERVICE DATA

Lack of sensitivity and poor tone quality may be due to any one or a combination of causes such as weak or defective tubes or speaker, open or grounded bias resistor, bypass condenser, etc. Never attempt to realign set until all other possible sources of trouble have been first thoroughly investigated and definitely proved not to be the cause.

NOTE: IT IS ABSOLUTELY NECESSARY THAT AN ACCURATELY CALIBRATED TEST OSCILLATOR WITH SOME TYPE OF OUTPUT MEASURING DEVICE BE USED WHEN ALIGNING THE RECEIVER AND THAT THE PROCEDURE BE CAREFULLY FOLLOWED, OTHERWISE THE RECEIVER WILL BE INSENSITIVE AND THE DIAL CALIBRATION WILL BE INCORRECT. THE TRIMMERS WILL BE REFERRED TO BY THEIR FUNCTION AS INDICATED ON THE PARTS DIAGRAM.

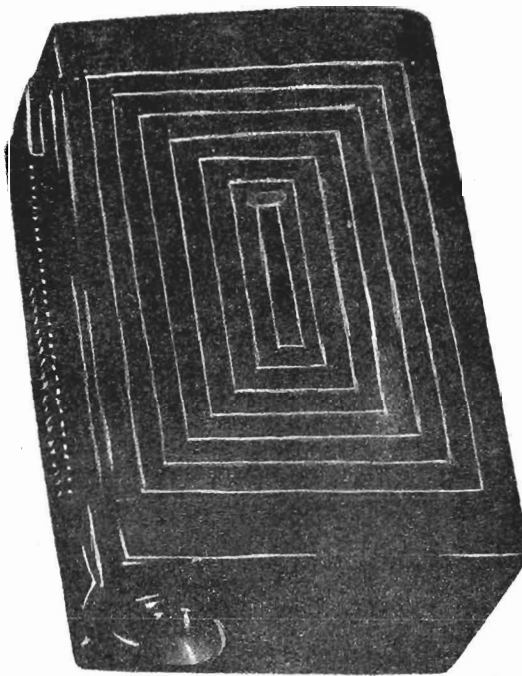

BATTERY INSTALLATION

BATTERY INSTALLATION: Before installing new batteries or replacing old ones, turn the volume control to the extreme left or "OFF" position.

Attach the connector with the snap-on fasteners to the "B" battery (90 Volt) and insert battery into the left hand side of the battery retaining area of the cabinet back so that the connector faces in the direction of the top of the receiver. Insert the prongs of the other battery connector into the socket of the "A" battery (4-1/2 Volt) and place battery in cabinet back so that the connector faces the outside wall of cabinet.

This receiver will accommodate any of the batteries listed below: (No preference is intended by the order of listing.)

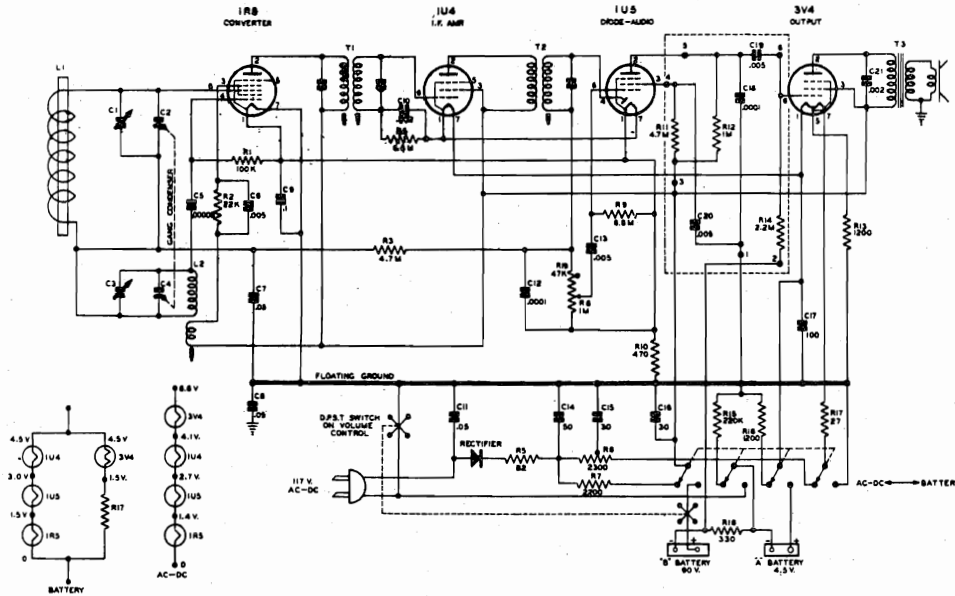

ALIGNMENT PROCEDURE

GENERAL DATA. The alignment of this receiver requires the use of a test oscillator that will cover the frequencies of 455,600,1400 and 1620 KC and an output meter to be connected across the primary or secondary of the output transformer. If possible, all alignments should be made with the volume control on maximum and the test oscillator output as low as possible to prevent the AVC from operating and giving false readings.

PARTS LIST

SCHEMATIC LOCATION	PART NUMBER	DESCRIPTION
C18		(.0001 MFD.)
C19, C20		(.005 MFD.)
R11	N-8330	Couplate (4.7 Megohm)
R12		(1.0 Megohm)
R14		(2.2 Megohm)
C6, C13	N-4894	Condenser, Paper .005 MFD. 600 V.
C7, C8	N-1345	Condenser, Paper .05 MFD. 200 V.
C9	N-1351	Condenser, Paper .1 MFD. 200 V.
C10, C21	N-6377	Condenser, Paper .002 MFD. 600 V.
C11	N-1346	Condenser, Paper .05 MFD. 400 V.
C12	N-6015	Condenser, Paper 100 MMFS. 500 V.
C14		(50 MFD. 150 V.)
C15	N-6841	Condenser, Electrolytic (30 MFD. 150 V.)
C16		(30 MFD. 150 V.)
C17		(100 MFD. 25 V.)
L1	N-6681	Speaker, 4" P.M.
	N-8328	Coil, Loop - Iron Rod Type
T1	N-7981	Coil, 1st. I.F.
T2	N-8326	Coil, 2nd. I.F.
L2	N-8327	Coil, Oscillator
T3	N-8329	Transformer, Output
	N-8331	Rectifier, Selenium
	N-5951	Switch, Power-Changeover

ALIGNMENT PROCEDURE CHART

STEP NO.	POSITION OF GANG	SIGNAL GENERATOR FREQUENCY	GENERATOR CONNECTION	DUMMY ANTENNA	ADJUSTMENT	TYPE OF ADJUSTMENT
1	Any point where no interfering signal is received	Exactly 455 KC	High side to grid of 1U3 tube. Low side to common negative	.05 MFD Condenser	Slug at top of 2nd. I.F. (T2) and then each of the slugs of the 1st. I.F.	For Maximum Output.
2	Exactly 1620 KC	Exactly 1620 KC.	DUMMY	2 Turns of hookup wire 6" in Diameter. (Place approximately a foot from end of, and in same axis as loop.)	Front Gang Trimmer	For Maximum Output.
3	Approx. 1400 KC.	Approx. 1400 KC			Rear Gang Trimmer	For Maximum Output.
4	Exactly 600 KC	Exactly 600 KC	ANTENNA		Slug in Oscillator Coil. (L2)	For Maximum Output.
5					Repeat Steps 2 and 3.	

PARTS LIST

SCHEMATIC LOCATION	PART NUMBER	DESCRIPTION
R1	N-1973	Resistor 100,000 Ohm 1/2W. 10%
R2	N-6012	Resistor 22,000 Ohm 1/2W. 10%
R3	N-4061	Resistor 4.7 Megohm 1/2W. 20%
R4, R9	N-4028	Resistor 6.8 Megohm 1/2W. 20%
R5	N-4023	Resistor 82 Ohm 2.0W. 10%
R6	N-8333	Resistor 2,300 Ohm 5.6W. 5% (Center Tapped)

PARTS LIST

SCHEMATIC LOCATION	PART NUMBER	DESCRIPTION
R7	N-4896	Resistor 2,200 Ohm 1/2W. 10%
R8	N-8332	Volume Control with Switch 1.0 Megohm
R10	N-4066	Resistor 470 Ohm 1/2W. 10%
R13, R16	N-6793	Resistor 1,200 Ohm 1/2W. 10%
R15	N-4026	Resistor 220,000 Ohm 1/2W. 20%
R17	N-6792	Resistor 27 Ohm 1/2W. 10%
R18	N-4420	Resistor 330 Ohm 1/2W. 10%

N-8381

This receiver may be operated on either AC or DC, 105-125 volts, 50-60 cycles.

FM 88 to 108 MC.
AM 540 to 1700 KC.

outlet. Should noticeable hum be detected when operating on AC (Alternating Current), reverse the line cord plug in the power outlet.

Antenna Connections:

It is equipped with built-in AM and FM antennae so that in primary listening areas an outside antenna is not necessary. **WHEN LISTENING TO FM BY USING THE BUILT-IN ANTENNA, KEEP THE ELECTRIC LINE CORD EXTENDED TO ITS FULL LENGTH.**

For weak or distant stations there are provisions made in the rear for antenna connections. A terminal strip with two screw connections for the lead-in wires from the FM antenna, also a wire coming out the back of the receiver for an external AM antenna.

When using the built-in antenna on FM, the lug coming out between the two screw connections on the terminal strip in the rear, must be connected to the screw connection marked "ANT." When using an external FM antenna disconnect this wire and connect external antenna lead-in wires to the two screw connections.

Station Selector:

The knob on the extreme right hand side of the cabinet operates the tuning condenser on both AM and FM and simultaneously moves the indicating pointer. Ease and accuracy in tuning is made possible due to a reduction drive.

Band Switch:

The second knob from the right is the AM-FM band switch. This is a two position switch. When the switch is in the counterclockwise position, AM (Standard Broadcast) stations may be tuned in. When the switch is in the clockwise position, FM (Frequency Modulation) stations may be tuned in.

Volume Control and Power Switch:

The third knob from the right is the volume control and power switch. When the control is in the extreme counterclockwise position the power is "OFF." From this position, a slight clockwise rotation will turn the power "ON." By further rotation in this direction volume may be increased to any degree until the full output of the receiver is obtained.

Tone Switch:

The fourth knob from the right is the tone switch. For normal operation the switch should be clockwise. For increased bass response turn switch fully counterclockwise.

Notes:

Since this receiver has a loop-tenna on AM which has a directional effect, it may be necessary at times to turn the receiver for best reception. This set will operate properly only after the tubes are sufficiently heated. This may take two minutes after the power switch is turned "ON." If the receiver is being operated on DC (Direct Current) and no signals are heard after two minutes, reverse the line cord plug in the power

Servicing

(For Use of Radio Technician):

Alignment of the receiver will, in most cases, be unnecessary unless an RF or IF transformer is replaced or the adjustment has been tampered with. The IF slugs are slotted for a small size fiber screwdriver. Do not put excessive pressure on the aligning tool or the threads in the coil-form will be stripped and adjustments will be impossible.

IF Alignment:

Set bandswitch to AM position. Connect the signal generator, modulated at 400 cycles, through a 0.01 Mfd condenser to the grid of the 12AT7 converter tube. Connect the low side of the generator through a 0.1 Mfd condenser to the receiver chassis. Adjust the signal generator to 455 KC. Tune primary and secondary slugs of T3 & T5, AM-IF Transformers, for maximum output.

For FM alignment set bandswitch to FM position and leave generator connected to the grid of the 12AT7 converter tube. Adjust generator to 10.7 MC. Connect 20,000 ohm per volt or VTVM meter as in note "1" of schematic diagram. Tune primary of T1, bottom slug, and both primary and secondary of T2 & T4 for maximum indication on meter. To align secondary of Ratio Detector Transformer connect meter as in note "2" of schematic diagram. Tune top slug through positive and negative indication and then slowly return until meter reads zero. This is in the center of the "S" curve.

RF Alignment:

Set bandswitch to AM position. Connect signal generator, modulated at 400 cycles, to external antenna lead and to ground through a 0.1 Mfd condenser and adjust to 1700 KC. Set dial pointer to 1700 KC and tune signal for maximum output with oscillator trimmer. Next set generator to 1500 KC and tune in this signal on the receiver. Then adjust RF trimmer for maximum output.

Set bandswitch to FM position. Connect in series with each generator lead a carbon 150 ohm resistor and connect to rear antenna terminal board. Adjust generator and dial pointer to 108 MC. Peak oscillator trimmer for maximum signal output. Next set generator to 105 MC and tune in this signal on receiver. Then peak RF trimmer for maximum output. No adjustment is necessary at the low end because a special compensated fixed padder is used. Set the generator to 94 MC and tune the FM antenna coil for maximum.

In all the IF and RF adjustments it is important to keep the signal generator output as low as possible. It is extremely necessary in making the RF adjustments, that the fundamental oscillator signal be tuned in and not the image frequency. This can be checked by the use of a calibrated wavemeter.

MODEL 8J702

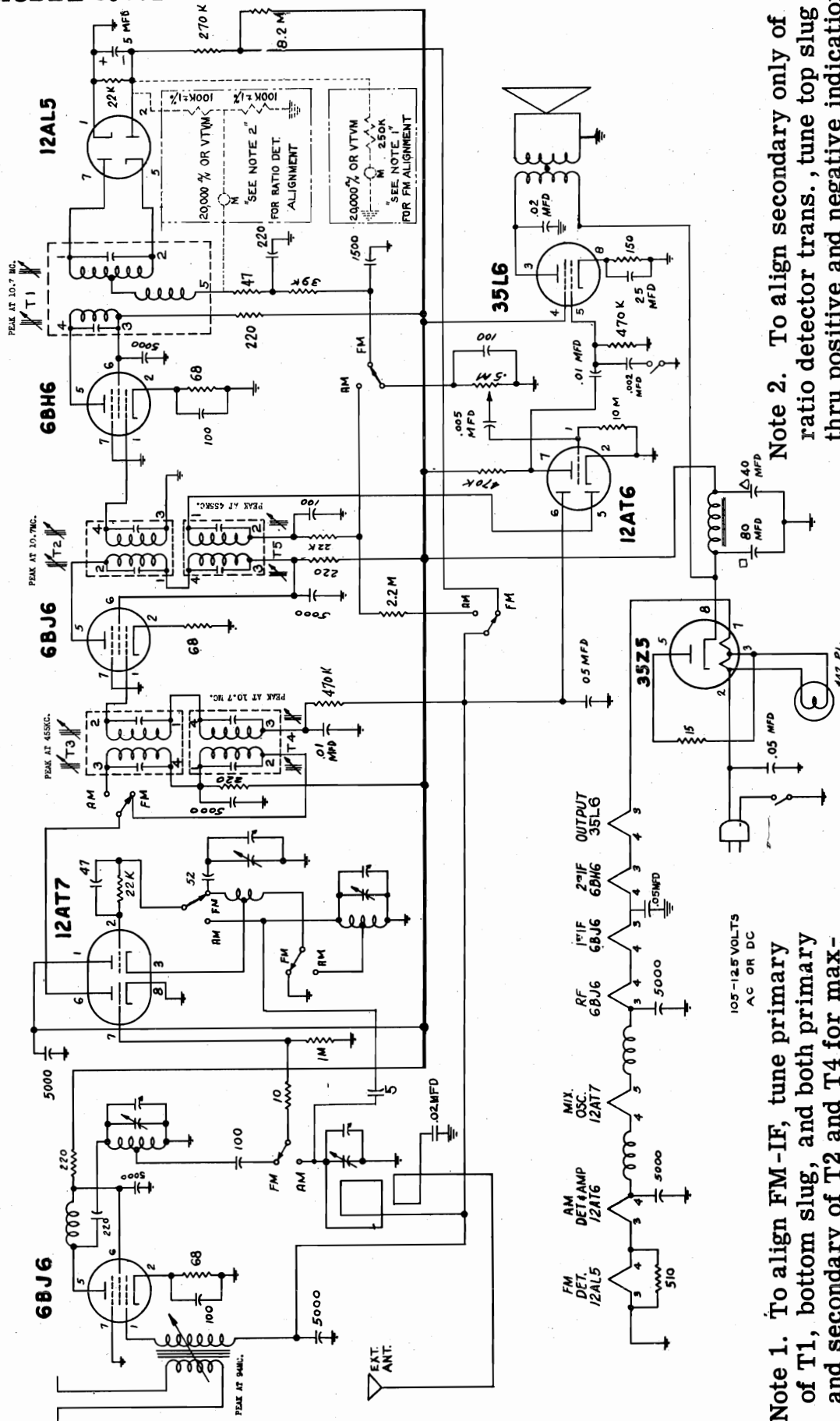

Note 2. To align secondary only of ratio detector trans., tune top slug thru positive and negative indication of meter and then slowly return until meter reads zero.

Note 1. To align FM-IF, tune primary of T1, bottom slug, and both primary and secondary of T2 and T4 for maximum indication of meter.

NOTE:
 ALL CAPACITANCE VALUES IN MMFD EXCEPT WHERE OTHERWISE SPECIFIED.
 ALL RESISTANCE VALUES IN OHMS EXCEPT WHERE OTHERWISE SPECIFIED.

GENERAL INFORMATION

TYPE - FM-AM Radio Phonograph Combination

TUNING RANGE - AM 535 to 1620 Kc AM IF - 455 Kc
 FM 88 to 108 Mc FM IF - 10.7 Mc

TUBE COMPLEMENT - 6BA6 - FM-AM RF Amplifier
 6BA7 - FM-AM Converter
 6BA6 - FM-AM IF Amplifier
 6BA6 - FM IF Amplifier
 6AL5 - FM Ratio Detector
 6AV6 - AM Det & 1st Audio Amp
 6K6GT - Power Amplifier
 5Y3GT - Rectifier

POWER SUPPLY - 117 volts, 60 cycles AC only; 85 watts, including phono motor

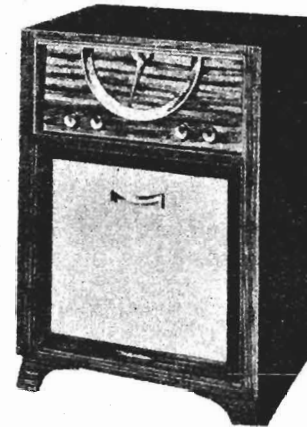

INSTALLATION & OPERATING INSTRUCTIONS

ANTENNAS

No outside antenna or ground is normally required for standard broadcast (AM) reception, as a loop antenna is located inside the cabinet. Antenna connections are shown in Figure 1. In locations where additional pick-up is desired, an external antenna may be connected to the clip marked "EXT BC ANT" on the loop antenna.

An FM antenna, built into the power cord, eliminates the need for an external FM antenna when the receiver is used in normal FM service areas, such as are found in and for a few miles around metropolitan areas. In "fringe" or weak signal areas, improved FM reception can be obtained by using an outside FM antenna. The external antenna should be connected through a 300 ohm twin transmission line to the 1st and 2nd screws on the terminal strip on the chassis, as in Figure 1. The link between the 2nd and 3rd screws should be opened. Orient the antenna to obtain maximum volume of the FM stations.

For best FM reception from the built-in power line cord antenna, it is important to stretch the cord to its full length. Changing the direction or position of the line cord, or reversing the plug in the wall outlet, will often improve reception from weak stations. Connect the link between the 2nd and 3rd screws on the terminal strip on the chassis when the built-in antenna is used.

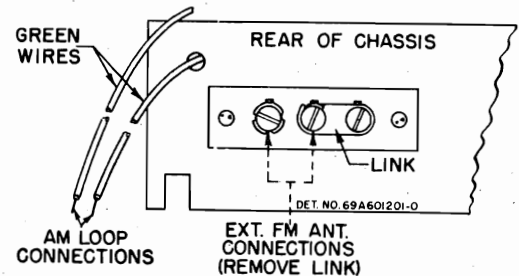

FIGURE 1. ANTENNA CONNECTIONS

CONTROLS

Refer to Figure 2 for the locations of the radio operating controls.

Power for both the radio and the record changer is controlled by the VOL-ON-OFF knob.

The phonograph motor will not operate, however, until the PHONO-TONE-RADIO knob is rotated also to "PHONO".

Tuning of FM stations should be done very carefully, for best sound reproduction, not necessarily for the strongest volume received.

DET. No. 69B600297-0



FIGURE 2. OPERATING CONTROLS

MODEL 8J703

ALIGNMENT

GENERAL INFORMATION

1. Maximum performance can be obtained only if extreme care is exercised during alignment.
2. Use a small fibre screwdriver for aligning the IF transformers.
3. Refer to Figure 4 for the location of all alignment trimmers and cores.
4. As the stages are brought into alignment, reduce the signal generator output to a low value to avoid overloading the receiver.

ORDER OF ALIGNMENT AND EQUIPMENT REQUIRED

1. AM Broadcast Band IF & RF Alignment
 - a. 455 to 1620 Kc AM signal generator
 - b. Low range output meter.
- 2(A) FM Band IF & RF Alignment (preferred method)
 - a. 10.7 to 108 Mc FM signal generator
 - b. Oscilloscope
- (B) FM Band IF & RF Alignment (alternate method)
 - a. 10.7 to 108 Mc signal generator (unmodulated)
 - b. Low range DC electronic voltmeter

AM BROADCAST BAND - IF & RF ALIGNMENT

1. Connect the AM signal generator as in chart below, with 400 cycle, 30% modulation.
2. Connect the output meter across the speaker voice coil. Throughout alignment, reduce the generator output to a level which produces less than 1.27 volts (.5 watt) across the voice coil to avoid overloading the receiver.
3. Set the bandswitch to the AM position.
4. Turn the receiver volume control to maximum.
5. Proceed as shown in the following chart.

STEP	DUMMY ANTENNA	GENERATOR CONNECTION	GENERATOR FREQUENCY	GANG SETTING	ADJUST	REMARKS
IF ALIGNMENT						
1.	.1 mf	Grid of conv. V-2 (pin 7, 6BA7)	455 Kc	Fully opened	1, 2, 3 & 4 (IF cores)	Adjust for maximum.
RF ALIGNMENT						
2.	.1 mf	Grid of conv. V-2 (pin 7, 6BA7)	1620 Kc	Fully opened	5 (AM Osc)	Adjust for maximum. *
3.	-	-	-	-	-	Connect AM loop to chassis.
4.	-	Across radiation loop**	1400 Kc	Tune in signal	8 (AM Ant)	Adjust for maximum.

5. If, after the receiver has been aligned as above, it is found to be badly off calibration, it will be necessary to adjust oscillator core (7) as follows: connect the generator to the grid of the converter tube and, with the gang fully closed, adjust core (7) at 535 kc. It is advisable to repeat the oscillator adjustments at 1620 kc and 535 kc several times until the tuning range is correct. Core (7) has been pre-set at the factory and normally should require no retuning.

* If difficulty is encountered in tuning trimmer (5), adjust trimmer (6) to 1/2 turn from tight.

** Connect generator output across 5" diameter, 5 turn loop and couple inductively to receiver loop. Keep loops at least 12" apart.

FM BAND - IF & RF ALIGNMENT (PREFERRED METHOD)

1. The following FM alignment procedure, using an FM signal generator and an oscilloscope, is to be preferred because the actual response pattern may be observed on the scope and adjusted for best symmetry and maximum amplitude.
2. Connect the vertical input terminals of the oscilloscope between the chassis and the junction of resistor R-18 (47K) and capacitor C-23 (1000 mmf).
3. Connect the FM signal generator sync voltage output terminals, through a phase shifting network, to the horizontal input terminals of the scope, as in Figure 5. (Other values of resistance and capacitance may be required, depending upon the scope). The phasing control should be adjusted to give only one trace on the scope. NOTE: If the FM generator has a built-in phase control, the phase shifting network is not necessary.
4. Set the bandswitch to the FM position.
5. Throughout alignment, reduce the generator output to keep the signal just above the noise level, to avoid

SERVICE NOTES

TO REMOVE CHASSIS FROM CABINET:

1. Remove the screws from the cabinet back.
2. Disconnect the phono power lead, the phono pick-up lead, the speaker leads, the line cord, and the antenna loop leads.
3. Remove the pointer escutcheon by pulling it downward.
4. Turn the tuning knob counterclockwise until the pointer reaches the extreme low frequency end of the dial scale.
5. From the back of the cabinet, loosen the pointer adjustment setscrew (see Figure 3) and pull the pointer and shaft assembly from the chassis. CAUTION: Do not remove the nut from the front of the pointer, as the detent ball and spring will fall out, and may become lost.
6. Pull off the control knobs.
7. Remove the three chassis mounting screws, from

beneath the chassis.

8. Slide the chassis from the cabinet.

TO CALIBRATE DIAL:

1. Turn the tuning knob counterclockwise until the end of its travel is reached.
2. From the back of the cabinet, loosen the pointer adjustment setscrew (see Figure 3). CAUTION: Do not remove the nut from the front of the pointer.
3. Move the pointer until it is in a horizontal position (at the low frequency end of the dial scale).
4. Tighten the adjustment setscrew.

NOTE: If the pointer is moved by hand accidentally, it will be released from a detent in the pointer collar, and no damage to the tuning mechanism will result. To reset the pointer, move it back and forth until it again engages in the detent.

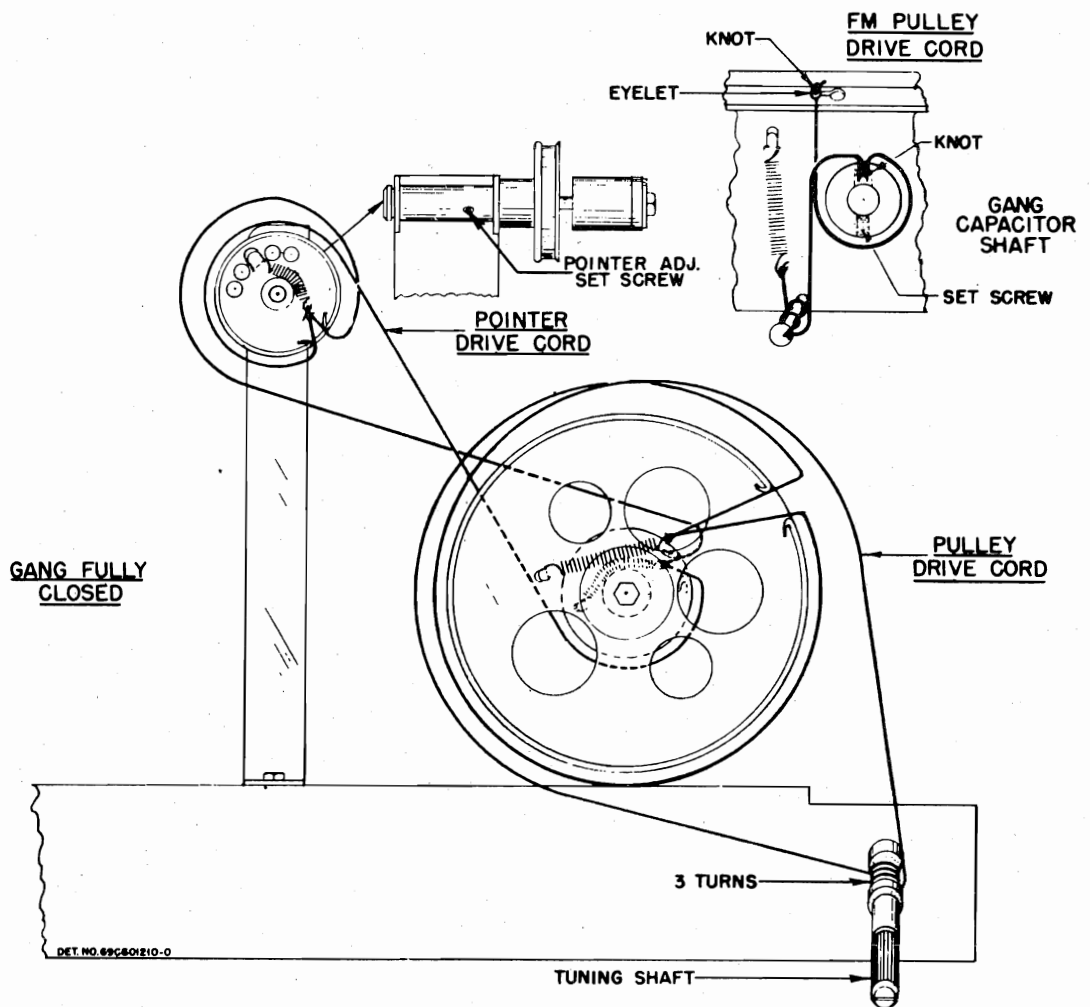
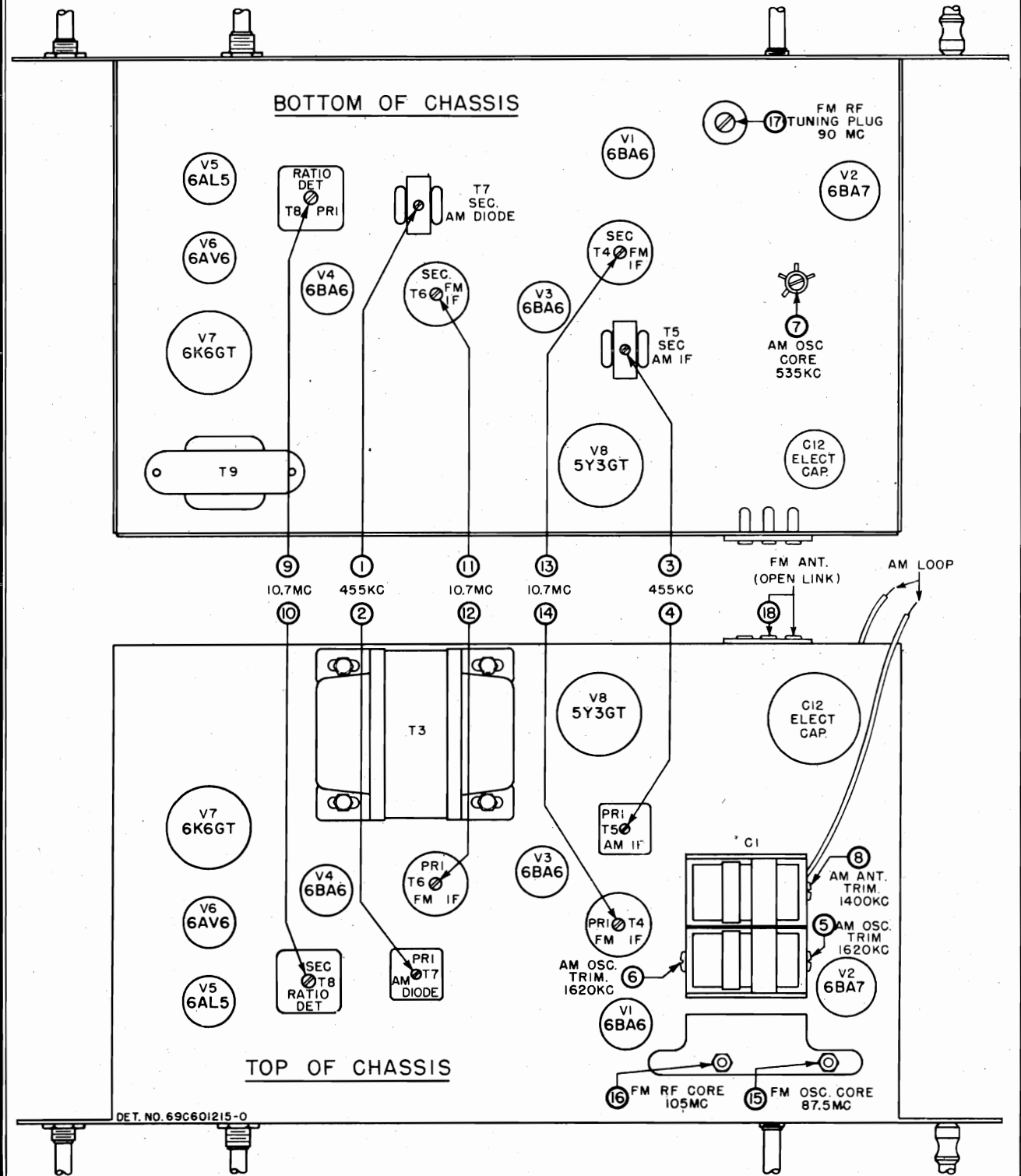

FIGURE 3. POINTER AND DRIVE CORD RESTRINGING DETAIL



DET. NO. 69C601215-0

FIGURE 4. TUBE AND TRIMMER LOCATIONS

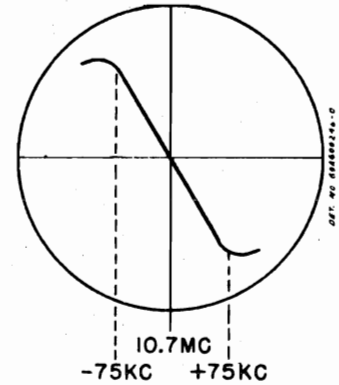
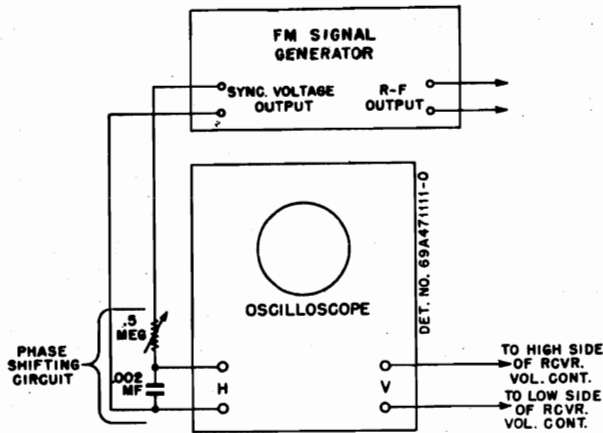

FIGURE 6. RATIO DETECTOR WAVEFORM

overloading the receiver.

FIGURE 5. FM SIGNAL GENERATOR & OSCILLOSCOPE HOOK-UP

6. Proceed as shown in the following chart.

STEP	DUMMY ANTENNA	GENERATOR CONNECTION	GENERATOR FREQUENCY	TUNER SETTING	ADJUST	REMARKS
IF ALIGNMENT						
1.	1000 mmf	Grid of 2nd IF Amp V-4 (pin 1, 6BA6)	10.7 mc ±100 kc dev	Fully opened	9 (ratio det pri)	Adjust for maximum amplitude of pattern. *
2.	1000 mmf	Grid of 2nd IF Amp V-4 (pin 1, 6BA6)	10.7 mc ±100 kc dev	Fully opened	10 (ratio det sec)	Adjust for symmetrical curve, as shown in Figure 6.
3.	-	-	-	-	-	Repeat steps 1 & 2 for maximum amplitude and best symmetry.
4.	1000 mmf	Grid of 1st IF Amp V-3 (pin 1, 6BA6)	10.7 mc ±100 kc dev	Fully opened	11 & 12 (2nd IF sec & pri)	Adjust for maximum amplitude of pattern. *
5.	1000 mmf	Grid of conv. V-2 (pin 7, 6BA7)	10.7 mc ±100 kc dev	Fully opened	13 & 14 (1st IF sec & pri)	Adjust for maximum amplitude of pattern. *
6.	1000 mmf	Grid of conv. V-2 (pin 7, 6BA7)	10.7 mc ±100 kc dev	Fully opened	11, 12, 13 & 14	Readjust for maximum amplitude and best symmetry.
RF ALIGNMENT						
7.	270 ohms	FM terminal 18 on rear of chassis (open link)	87.5 mc ±22-1/2 kc dev	Fully closed	15 (osc core)	Adjust for maximum amplitude of pattern. *
8.	-	-	-	Fully closed	16 (RF core)	Turn counterclockwise until core is at bottom of pipe, then turn four turns clockwise.
9.	270 ohms	FM terminal 18 on rear of chassis	90 mc ±22-1/2 kc dev	Tune in signal	17 (RF tuning plug)	Adjust for maximum amplitude of pattern. *
10.	270 ohms	FM terminal 18 on rear of chassis	105 mc ±22-1/2 kc dev	Tune in signal	16 (RF core)	Adjust for maximum amplitude of pattern. *
11.	-	-	-	-	-	Repeat steps 9 & 10, until no further adjustment is necessary.

* An output meter across the speaker voice coil will also indicate maximum amplitude. It should not be used in place of the scope, however, since it will not show symmetry of the curve.

MODEL 8J703

FM BAND - IF & RF ALIGNMENT (ALTERNATE METHOD)

1. The following procedure for FM alignment, with an unmodulated carrier generator and a DC electronic voltmeter, is not as desirable as the preceding method; but it may be used if no FM generator is available.
2. Connect the signal generator as in chart below, with no modulation.
3. Set the bandswitch to the FM position.
4. Except in step 2 below, connect the electronic voltmeter across resistor R-19 (33K) in the ratio detector stage.
5. Throughout alignment reduce the signal generator output to a value which produces no more than a 5 volt rise above no signal voltage, to avoid overloading the receiver.
6. In step 2 below, connect two 100K ohm resistors in series across R-19. Connect the electronic voltmeter between the volume control side of resistor R-18 (47K) and the junction of the two 100K resistors, with the low side of the meter at the 100K resistors.
7. Proceed as shown in the following chart.

STEP	DUMMY ANTENNA	GENERATOR CONNECTION	GENERATOR FREQUENCY	TUNER SETTING	ADJUST	REMARKS
IF ALIGNMENT						
1.	1000 mmf	Grid of conv. V-2 (pin 7, 6BA7)	10.7 mc	Fully opened	9, 11, 12, 13 & 14 (IF cores)	Adjust for maximum.
2.	1000 mmf	Grid of conv. V-2 (pin 7, 6BA7)	10.7 mc	Fully opened	10 (ratio det sec)	Adjust for zero (connect meter as in step 6 above.)
RF ALIGNMENT						
3.	270 ohms	FM terminal 18 on rear of chassis (open link)	87.5 mc	Fully closed	15 (osc core)	Adjust for maximum.
4.	-	-	-	Fully closed	16 (RF core)	Turn counterclockwise until core is at bottom of pipe, then turn four turns clockwise.
5.	270 ohms	FM terminal 18 on rear of chassis	90 mc	Tune in signal	17 (RF tuning plug)	Adjust for maximum.
6.	270 ohms	FM terminal 18 on rear of chassis	105 mc	Tune in signal	16 (RF core)	Adjust for maximum.
7.	-	-	-	-	-	Repeat steps 5 & 6 until no further adjustment is necessary.

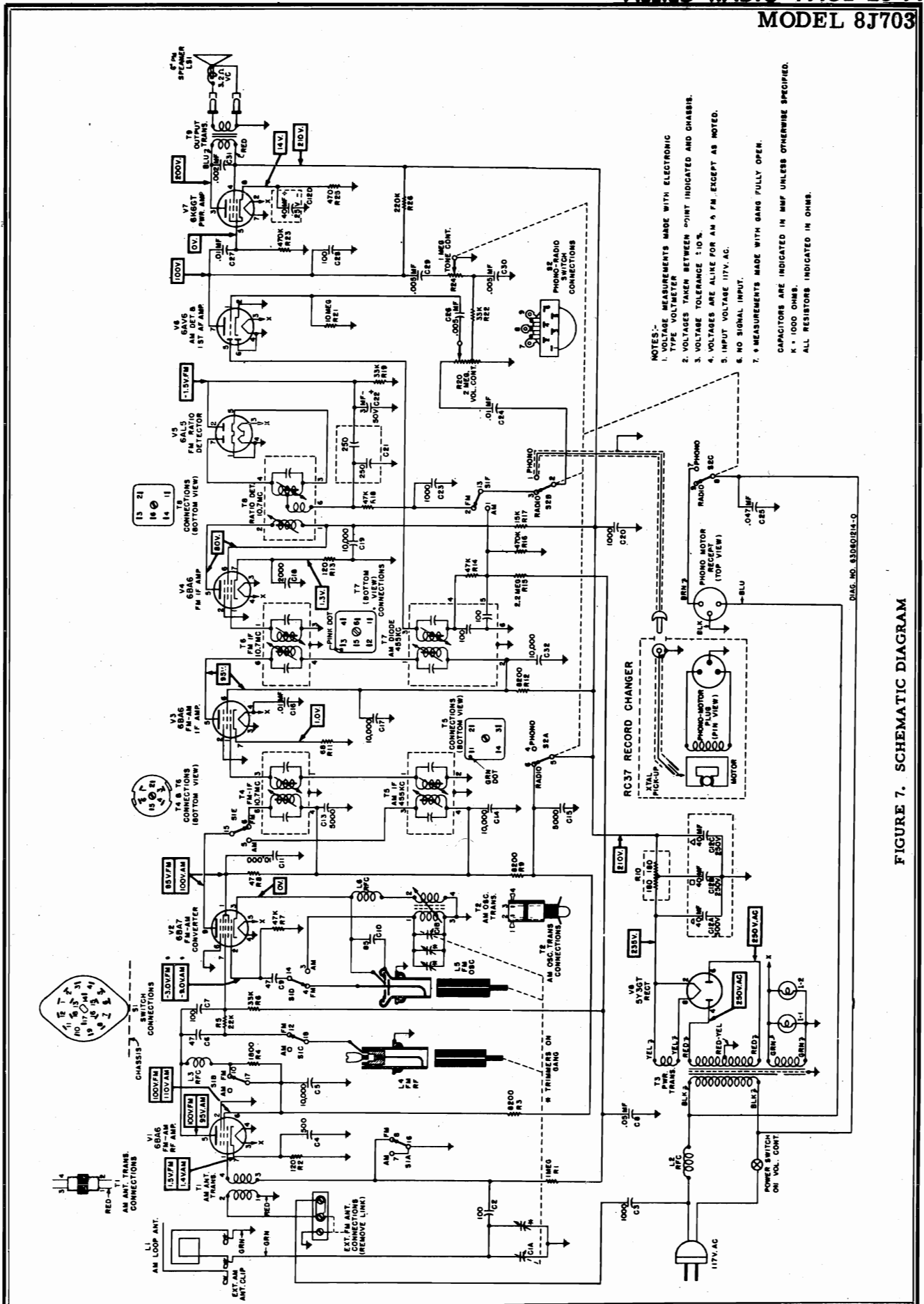

- NOTES:-
1. VOLTAGE MEASUREMENTS MADE WITH ELECTRONIC TYPE VOLTMETER
 2. VOLTAGE TAKEN BETWEEN POINT INDICATED AND CHASSIS.
 3. VOLTAGE TOLERANCE ±10%.
 4. VOLTAGES ARE ALIKE FOR AM & FM, EXCEPT AS NOTED.
 5. INPUT VOLTAGE 117V. AC.
 6. NO SIGNAL INPUT.
 7. NO MEASUREMENTS MADE WITH GANG FULLY OPEN.
- CAPACITORS ARE INDICATED IN MMF UNLESS OTHERWISE SPECIFIED.
K = 1000 OHMS.
ALL RESISTORS INDICATED IN OHMS.

FIGURE 7. SCHEMATIC DIAGRAM

Part Number	Description	Part Number	Description
42A48548	Clip, coil can mtg (AM IF transformer)	5S5405	Terminal, pin (on speaker leads)...
42B482867	Clip, spring: blued finish (holds FM IF transformer)	4A70015	Washer, "C" (tuning shaft mtg).....
11M8944	Cord, dial (pointer drive)	4A21941	Washer, "C" (holds pointer mtg shaft & pulley)
11M488137	Cord, dial (core drive)	4A600676	Washer, dog (AM-FM switch mtg).....
30K21859	Cord, line: with plug; 9 ft long	4S7582	Washer, flat: 1/2 x .195 x .033 stl; cad pl (pointer drive pulley mtg).....
46B692164	Core, iron and screw: green dot (FM osc tuning core)	MODEL 8FM21 CABINET PARTS	
46K692165	Core, iron and screw (FM RF tuning core)	43A4326	Ball, steel: 1/8" diameter (pointer detent)
15A600877	Cover, volume control: with insulator...	38K691915	Button, plug (on record changer).....
5S7866	Eyelet: .125 x .091 brass; nkl pl (core drive cord retainer)	16F600649	Cabinet, console: red-brown mahogany; complete less pointer escutcheon and dial scale
1X600495	Lead and Plug Assembly, phono pick-up...	13K600651	Cloth, grille: 17-1/2" x 18-1/4"; mahogany
4S9751	Lockwasher, int-ext: #8; cad pl (pointer drive pulley mtg)	15C600874	Cover, cabinet back
2S7019	Nut, hex: 4-40 x 1/4; cad pl (FM tuning core mtg)	34D600819	Dial scale
2S7051	Nut, hex palnut: 3/8-32 x 9/16; cad pl (control mtg)	34K600817	Escutcheon, pointer
35K691846	Pad, rubber: 1-hole (gang mtg).....	5S7870	Eyelet: brass (on RC drawer panel-holds extra spindle)
35A691845	Pad, rubber: 2-hole (gang mtg)	5A71081	Eyelet, chassis mtg: plain; 9/32" long.
28K71775	Plug, phono pick-up	5A600963	Eyelet, chassis mtg: pierced; 1/8" long
1X600828	Pulley Assembly, pointer & gang drive (includes 3-1/2" & 1-1/4" pulleys)...	5A71092	Grommet, chassis mtg: rubber
49A690562	Pulley, core drive: brass	36K601052	Knob, control (Vol-On-Off): walnut-mahog.
9A600040	Receptacle, phono motor: 3-prong; includes shell	36K601056	Knob, control (Phono-Tone-Radio): walnut-mahogany
5S8497	Rivet: .088 x 1/8 stl; nkl pl (anti-backlash clip mtg)	36K601057	Knob, control (AM-FM): walnut-mahogany...
5S7771	Rivet: .088 x 3/16 stl; nkl pl (min socket mtg)	36K601055	Knob, control (Tuning): walnut-mahogany..
5S7774	Rivet: .088 x 1/4 stl; nkl pl (noval socket mtg)	4S7657	Lockwasher, ext: #8; cad pl (sprk mtg)
5S7707	Rivet: .122 x 5/32 stl; nkl pl (term strip mtg)	2S7005	Nut, hex: 6-32 x 1/4 stl; cad pl (pointer mtg)
5S7701	Rivet: .122 x 3/16 stl; nkl pl (ant term strip mtg)	2S7003	Nut, hex: 8-32 x 5/16; cad pl (sprk mtg)
5S7700	Rivet: .122 x 1/4 stl; nkl pl (octal socket mtg)	62K70581	Overlay, logotype: "Motorola"; gold lacquer finish
5K13896	Rivet, shoulder (on core mtg brkt)....	1X600851	Pointer and Collar Assembly (less shaft and sleeve)
3S7163	Screw, machine: 8-32 x 1/4 plain hex head; cad pl (pointer drive pulley mtg).	55K600653	Pull, record changer drawer: satin brass.
3S7205	Screw, machine: 8-32 x 1/4 slotted locking hex head; cad pl (gang mtg)	3K600655	Screw, machine: 8-32 x 1/2 cross slot head; statuary bronze finish (RC drawer pull mtg)
3S2695	Screw, sheet metal: #6 x 3/16 PKZ plain hex head; cad pl (tuner brkt mtg)..	3S7536	Screw, sheet metal: #6 x 3/8 PKA slotted acorn head; antique copper finish (back cover mtg)
3S7454	Screw, sheet metal: #8 x 1/4 PKZ plain hex head; cad pl (pwr trans & pointer brkt mtg)	3K653	Screw, speaker mtg: 8-32 x 1-1/4"; copper oxide finish
3S7103	Setscrew: 8-32 x 1/8 Allen head; cad pl (core drive pulley & pointer mtg).....	1A690738	Shaft and Sleeve Assembly, pointer: less detent spring and ball, and pointer.....
1K601085	Shaft and Pulley Assembly, pointer mtg...	55K600654	Slide, record changer (on sides of RC drawer)
1X600489	Shaft, tuning: complete with pulley.....	28400199	Speednut: for .050 stud (dial scale mtg)
15A690616	Shell, receptacle (on phono motor receptacle)	41A690732	Spring, compression (pointer detent)..
26K485936	Shield, coil (for FM IF transformers)....	4S1765	Washer, flat: 1/2 x .147 x .015 stl; cad pl (pointer mtg)
9K600968	Socket, pilot light	4S7629	Washer, flat: 1/2 x 3/16 x .048 stl; cad pl (sprk mtg)
9K484167	Socket, tube: miniature; 7-prong.....	4A690729	Washer, spring (pointer mtg)
9A485495	Socket, tube: noval; 9-prong	MODEL 8FM21B CABINET PARTS -Same as 8FM21 except:	
9A76209	Socket, tube: octal	16K600650	Cabinet, console: blonde; complete, less pointer escutcheon and dial scale.....
41A690598	Spring, coil: 7 turns; cosmoline dipped (FM RF core mtg)	13K600652	Cloth, grille: 17-1/2" x 18-1/4"; eggshell
41K691840	Spring, coil: 8 turns; cop pl (FM osc core mtg)	36K601058	Knob, control (Vol-On-Off): tan
41A14244	Spring, tension (core & pointer drive cord)	36K601063	Knob, control (Phono-Tone-Radio): tan....
31K37504	Strip, terminal: 1 insulated lug; #1 mtg. 3/8" spacing	36K601064	Knob, control (AM-FM): tan
31K76184	Strip, terminal: 2 insulated lugs; #1 gnd; 3/8" spacing	36K601062	Knob, control (Tuning): tan
31K26235	Strip, terminal: 3 insulated lugs; #1 gnd; 3/8" spacing	3K600656	Screw, machine: 8-32 x 1/2 cross slot head; brass (RC drawer pull mtg).....
31K26658	Strip, terminal: 5 insulated lugs; #3 gnd; 3/8" spacing		
31A470403	Strip, terminal: 3-screw (antenna input).		

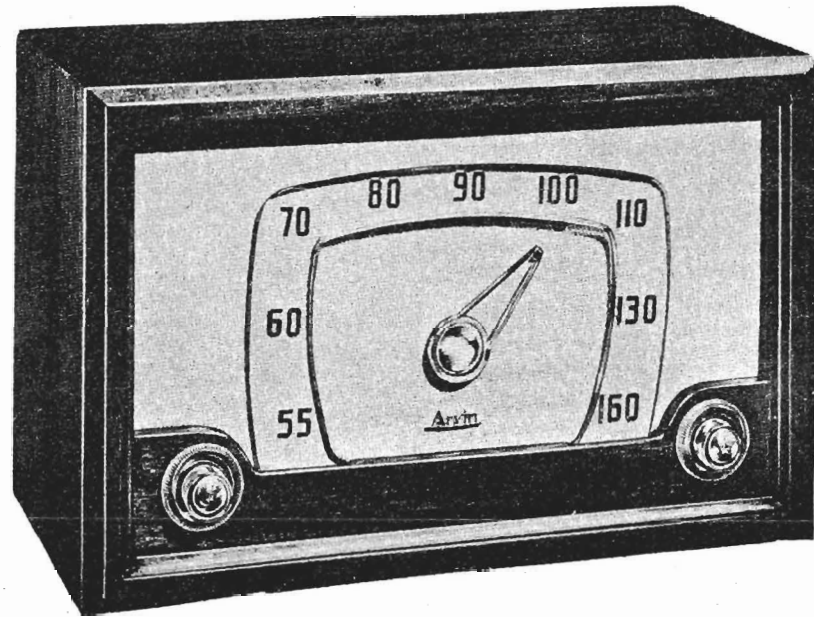

ELECTRICAL AND MECHANICAL SPECIFICATIONS

FREQUENCY RANGE

Broadcast 540-1600 kc
 IF 455 kc

TUBES AND FUNCTIONS

6BE6 Mixer-oscillator
 6BA6 I.F. AMP
 6AV6 Detector — AVC-AF.
 6V6 Output
 5Y3 Rectifier

POWER OUTPUT

Type: Beam tube
 Undistorted 3.5 Watts
 Maximum 4.5 Watts
 Plate Load 5000 Ohms

LOUD SPEAKER

Type. Permanent magnet, 2.15 oz., Alnico 5
 Size: 8 inch
 Voice coil impedance 3.2 Ohms

CHASSIS FEATURES

Automatic Volume Control
 Built-in Loop
 Underwriter's Listed

OPERATING CONTROLS

1. Right knob Tuning and Phono-Radio
2. Left knob ON-OFF, Volume and Tone

PHYSICAL DIMENSIONS

Length 15-1/8 inches
 Width 8 inches
 Height 9-5/8 inches

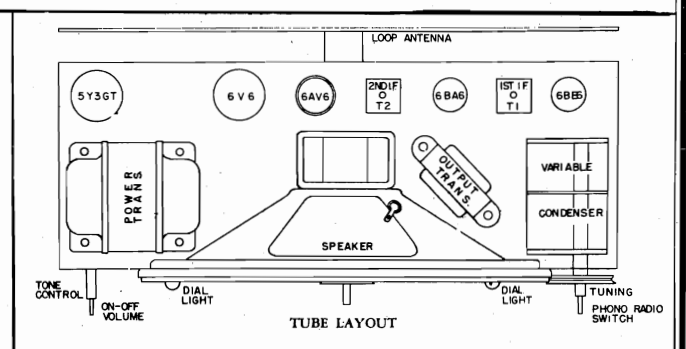
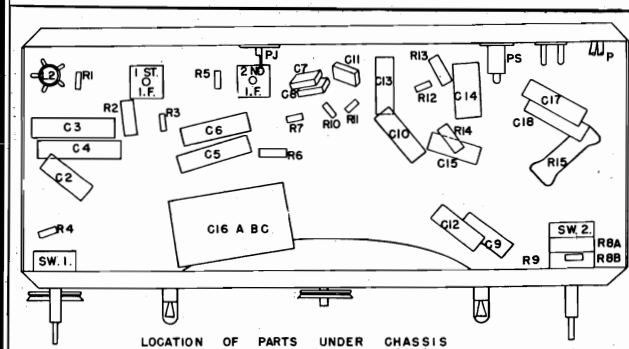
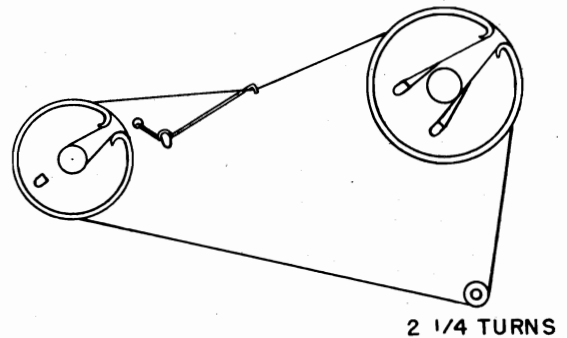

MODEL 551T, Ch. RE-297

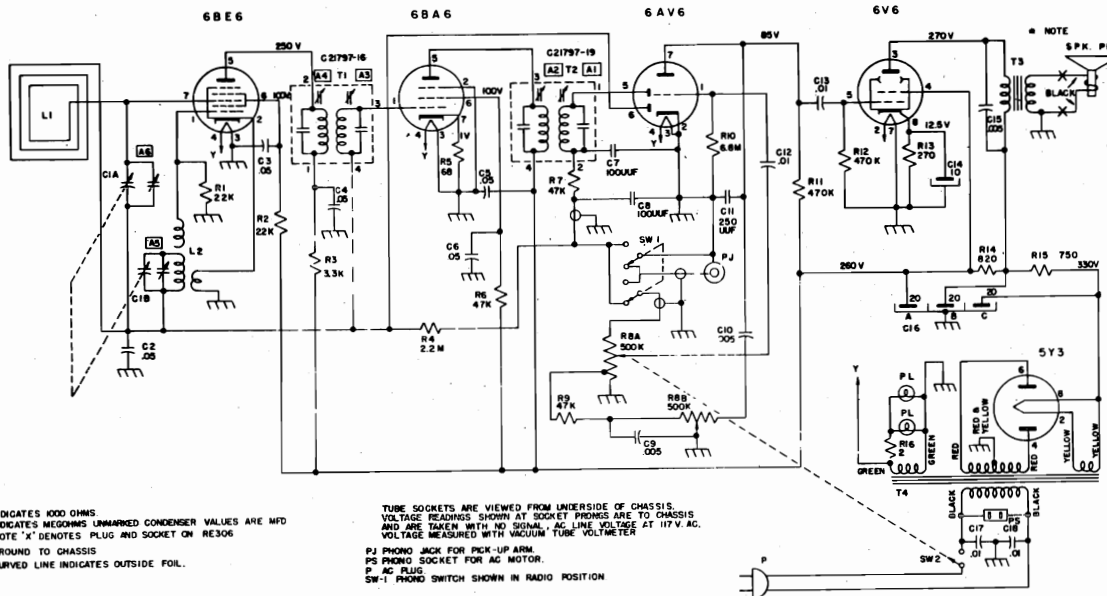

K INDICATES 1000 OHMS.
M INDICATES MEGOHMS UNMARKED CONDENSER VALUES ARE MFD
* NOTE "X" DENOTES PLUG AND SOCKET ON RES306
⊥ GROUND TO CHASSIS
⌒ CURVED LINE INDICATES OUTSIDE POIL.

TUBE SOCKETS ARE VIEWED FROM UNDERSIDE OF CHASSIS.
VOLTAGE READINGS SHOWN AT SOCKET PRONGS ARE TO CHASSIS
AND ARE TAKEN WITH NO SIGNAL. AC LINE VOLTAGE AT 117 V. AC.
VOLTAGE MEASURED WITH VACUUM TUBE VOLTMETER

PJ PHONO JACK FOR PICK-UP ARM
PS PHONO SOCKET FOR AC MOTOR
P AC PLUG
SW-1 PHONO SWITCH SHOWN IN RADIO POSITION

PRELIMINARY:

ALIGNMENT PROCEDURE

- Output meter connection..... Across loudspeaker voice coil
- Output meter reading to indicate .5 W (standard output)..... 1.26 volts
- Connection of generator ground lead..... Chassis
- Generator Modulation..... 30% 400 cycles
- Position of volume & tone control..... Fully clockwise
- Position of dial pointer with variable fully closed..... to left

1. Connect signal generator lead through a .05 uf condenser to converter grid. Open tuning condenser. Set signal generator to 455 Kc. Tune I.F. Trimmers A1, A2, A3 and A4 for maximum output.
2. Close tuning condenser and set pointer to left. Open tuning condenser. Connect signal generator to test loop or to blue lead on set loop. Set signal generator to 1650 Kc. Tune A5 trimmer on oscillator section of tuning condenser for maximum output.
3. Set signal generator to 1400 Kc. Adjust tuning shaft until maximum output is obtained. Tune antenna trimmer A6 on tuning condenser for greatest output. Reset tuning shaft until output is again maximum. Retune antenna trimmer. Repeat this cycle of operations at 1400 Kc. until no further increase of output can be obtained. Keep generator output at a low value to prevent detuning by A.V.C. action.
4. Set signal generator to 600 Kc. Adjust tuning shaft for maximum output. Adjust tuning condenser plate for maximum output if necessary.

Approximate sensitivities with 117 V. AC line voltage and .5 W. output across voice coil should be: Antenna, lead 600 Kc.—600 uv/m., 1000 Kc.—400 uv/m., 1400 Kc.—300 uv/m.

PARTS

Schematic Loc.	Part Number	Description	
L1	D24777	Antenna Loop Assembly	1.50
	R24876	Cabinet, Wood	11.20
C1A, B	C24305	Capacitor, Variable, 2 gang with Trimmers	2.10
C2	C20067-503	Capacitor, .05 mfd, 200 V, P.T.	.09
C3, C4, C5, C6	C20068-503	Capacitor, .05 mfd, 400 V, P.T.	.09
C7, C8	C20065-101	Capacitor, 100 mmfd, 500 V, Mica	.30
C9	C20067-502	Capacitor, .005 mfd, 200 V, P.T.	.20
C10	C20068-302	Capacitor, .003 mfd, 400 V, P.T.	.20
C11	C20065-251	Capacitor, 250 mmfd, 500 V, Mica	.20
C12, C13	C20068-103	Capacitor, .01 mfd, 400 V, P.T.	.20
C14	A22602	Capacitor, 10 mfd, 25 V, Electrolytic	.65
C15	C20069-302	Capacitor, .003 mfd, 600 V, P.T.	.20
C16A, B, C	C24415	Capacitor, 20-20-20 mfd, 450 V, Electrolytic	1.75
C17, C18	D20358-103	Capacitor, .01 mfd, 600 V, Molded	.50
	E24490	Carton, with Fillers	1.10
L2	AC24482-1	Coil, Oscillator Assembly	.10
R8A, B	C24535	Control, Volume and Tone, Dual 500K-500K ohms	.75
	A19132	Cord, Dial Drive	10 for .25
	D24439	Cover, Cabinet Rear	.35
	C24449	Dial, Pointer	.30
	E24447	Dial, Crystal	2.75
	AD24448-1	Grille, Assembly	1.00
	A24442-1	Knob, Volume, Radio-Phono	.09

Schematic Loc.	Part Number	Description	
	A24443-1	Knob, Tone, Tuning	.09
	A19351	Lamp, Dial, Mazda No. 47	.20
	B20138-15	Line Cord	.75
	A19552	Phono Jack	.10
	AC24475-1	Pointer, Shaft & Bracket Assembly	.35
R1	C20060-223	Resistor, 22K ohm, 20%, 1/4 W	.10
R2	C20302-223	Resistor, 22K ohm, 10%, 2 W	.10
R3	C20060-332	Resistor, 3.3K ohm, 20%, 1/4 W	.10
R4	C20060-225	Resistor, 2.2 megohm, 20%, 1/4 W	.10
R5	C20060-680	Resistor, 68 ohm, 20%, 1/4 W	.10
R6	C20070-473	Resistor, 47K ohm, 10%, 1 W	.10
R7, R9	C20060-473	Resistor, 47K ohm, 20%, 1/4 W	.10
R10	C20060-685	Resistor, 6.8 megohm, 20%, 1/4 W	.10
R11, R12	C20060-474	Resistor, 470K ohm, 20%, 1/4 W	.10
R13	C20070-271	Resistor, 270 ohm, 10%, 1 W	.15
	or		
	A24891	Resistor, 270 ohm, 10%, 1 W Wire	.15
R14	C20070-821	Resistor, 820 ohm, 10%, 1 W	.15
R15	C23970-14	Resistor, 750 ohm, 10%, 5 W Wire	.40
R16	A24761	Resistor, 2 ohm, 10%, 1/2 W Wire	.10
	A24435-1	Socket, Dial Lamp	.06
	A19551	Socket, AC Phono Motor	.25
SPK	D24402	Speaker, 6" x 9" P.M.	6.10
	A24653	Spring, Dial Drive Cord	.30
SW-1	C24438	Switch, Phono-Radio	.75
T1	C21797-16	Transformer, 1st I.F.	1.20
T2	C21797-19	Transformer, 2nd I.F.	1.25
T3	C24776-2	Transformer, Output	.61
T4	D24440	Transformer, Power	3.75

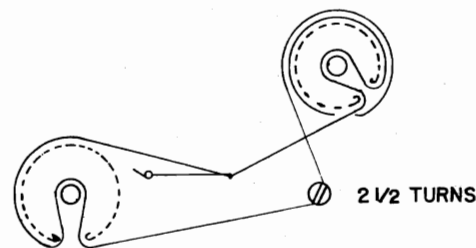
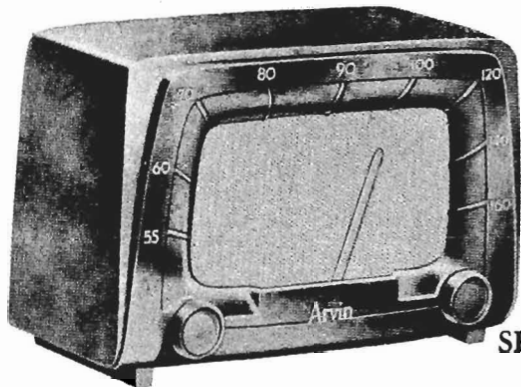

SPECIFICATIONS

FREQUENCY RANGE

Broadcast 540-1600 kc
 IF 455 kc

TUBES AND FUNCTIONS

12BE6 Mixer-oscillator
 12BA6 IF Amp.
 12AV6 DET-AVC AF Amp.
 50C5 Output
 35W4 Rectifier

POWER SUPPLY

105-125 Volts, AC-DC, 35 Watts

POWER OUTPUT

Undistorted 1 Watt
 Maximum 1.5 Watts
 Plate load 2000 Ohms

THE ANTENNA

This receiver has a built-in loop which gives satisfactory reception in most locations.

This receiver is designed to operate without a ground connection and no attempt should be made to use one.

LOUD SPEAKER

Type: Permanent magnet
 Size: 4 inch
 Voice coil impedance 3.2 Ohms

CHASSIS FEATURES

Automatic Volume Control
 Built-in Loop
 Underwriters' Listed

OPERATING CONTROLS

1. Left knob ON-OFF Sw and Volume
 2. Right knob Tuning

PHYSICAL DIMENSIONS

Length 11-5/16 inches
 Height 7-9/16 inches
 Depth 4 1/4 inches

ALIGNMENT PROCEDURE

PRELIMINARY:

- Output meter connection.....Across loudspeaker voice coil
- Output meter reading to indicate 500 milliwatts (standard output).....8 volts
- Dummy antenna value to be used in series with generator output.....See chart below
- Connection of generator output lead.....See chart below
- Connection of generator ground lead.....Floating ground
- Generator modulation.....30% 400 cycles
- Position of volume control Fully clockwise
- Position of dial pointer with variable fully closed.....Last mark at left end of dial

Position of Variable	Frequency of Generator	Dummy Antenna	Generator Output Connection	Trimmers Adjusted in Order Shown for Maximum Output	Function of Trimmer
Open	455	.05 mfd.	12BE6 Grid (Stator of C1A)	A1, A2, A3, A4,	IF
1400	1400		*Test Loop	A5, A6 on Variable Condenser	Osc. Ant.
600	600		*Test Loop	Check Point	

*Standard Hazeltine Test Loop Model 1150 or 3 turns of wire about 6" in diameter, placed about one foot from the set loop.

The alignment procedure should be repeated in the original order for greatest accuracy. Always keep the output from the signal generator at its lowest possible value to make the AVC action of the receiver ineffective.

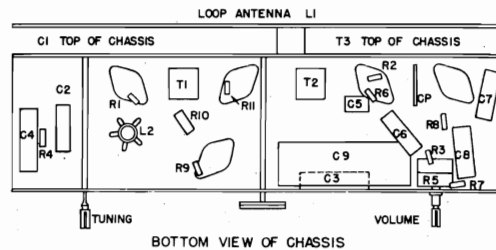
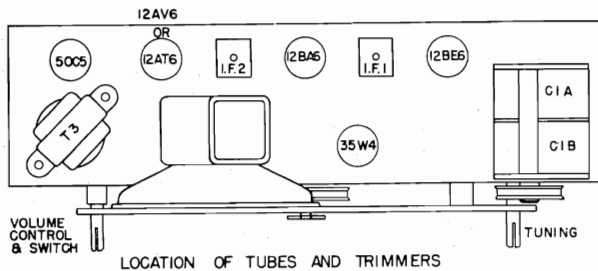
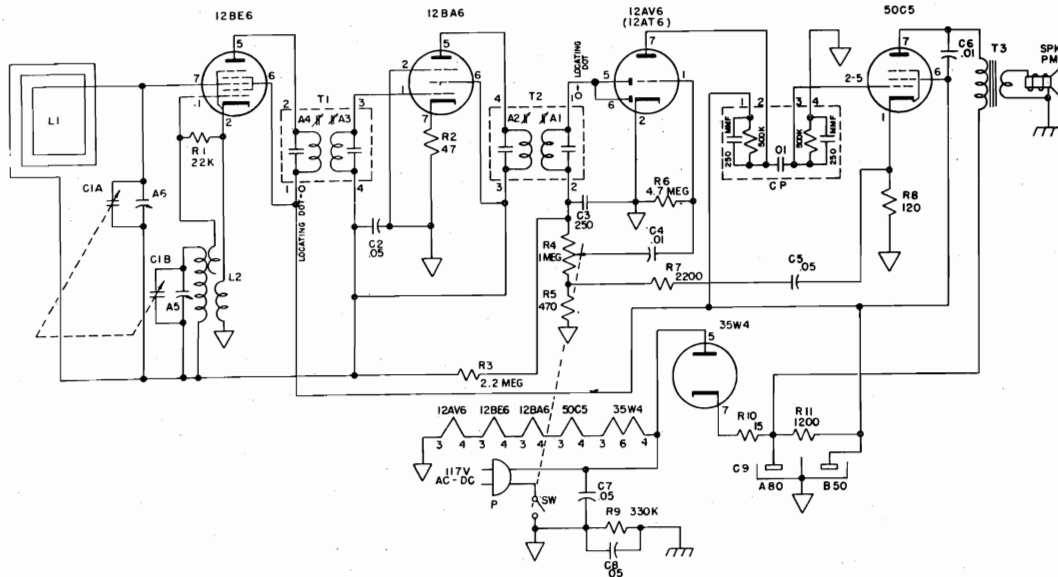

HOW TO ORDER PARTS

Replacement parts should be ordered by Arvin part number, description and model number of receiver from your Arvin Distributor. The Distributor will order direct from the factory. All prices subject to changes in accordance with O.P.S. regulations. Parts shipments are F.O.B. Columbus, Indiana.

PARTS LIST — 553T

Schematic Location	Part Number	Description	List Price	Schematic Location	Part Number	Description	List Price
L1	D24514	Antenna Loop & Rear Cover	1.80	C20138-18	Line Cord		.60
	B23456	Antenna Loop Mounting Bracket	.10	A24493	Pointer		.40
	R24491-1	Cabinet, Plastic, Walnut	3.25	R1	C20060-223	Resistor, 22K ohm, 20%, 1/4 W.	.10
C1A, B	C24516	Capacitor, Variable	2.25	R2	C20060-225	Resistor, 2.2 megohm, 20%, 1/4 W.	.10
C2, C8	C20067-503	Capacitor, .05 mf, 200 V., P.T.	.20	R3	C20060-471	Resistor, 470 ohm, 20%, 1/4 W.	.10
C3, C4	C20068-503	Capacitor, .05 mf, 400 V., P.T.	.20	R4	C20060-334	Resistor, 330K ohm, 20%, 1/4 W.	.10
C5	C20065-251	Capacitor, 250 mmf, 500 V, Mica	.20	R6	C20060-475	Resistor, 4.7 megohm, 20%, 1/4 W.	.10
C6, C7	C20068-103	Capacitor, .01 mf, 400 V, P.T.	.20	R7	C20060-222	Resistor, 2200 ohm, 20%, 1/4 W.	.10
C9	A24537	Capacitor, 50-80 mf, 150 V, Electrolytic	1.85	R8	C20120-121	Resistor, 120 ohm, 10%, 1/4 W.	.10
	E24497	Carton, Complete with Fillers	.35	R9	C20060-150	Resistor, 15 ohm, 20%, 1/4 W.	.10
L2	AC24210-1	Coil, Oscillator	.60	R10	C20070-122	Resistor, 1200 ohm, 10%, 1 W.	.15
R5	C24515	Control, Volume	.85	R11	C20060-470	Resistor, 47 ohm, 20%, 1/4 W.	.10
CP	A24084	Couplate	.45	SPR	C24513	Speaker, 4" P.M.	3.35
	AD24530-1			T1, T2	AA24607-1	Pointer Shaft & Pulley Assembly	.20
	or			T3	C21797-16	Transformer, I.F.	1.20
	AC24496-1	Grille, Assembly	.30		AC24542	Transformer, Output	1.25
	A24492-4	Knob, Control	.20		A24533	Tuning Shaft	.20
					A19361	Tuning Shaft Hair Pin Clip	.11

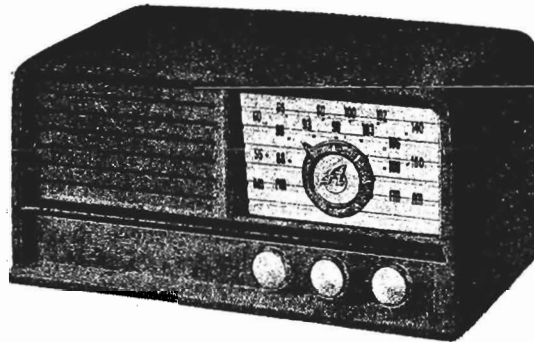

SPECIFICATIONS

FREQUENCY RANGE

Broadcast (AM)	540-1600 kc
IF	455 kc
FM	88-108 mc
IF	10.7 mc

TUBES AND FUNCTIONS

6BA6	FM R. F. Amp.
12AT7	FM Converter
6BE6	AM Converter
6BA6	AM-FM-IF Amp.
6BA6	FM, IF Amp.
6T8	FM-AM DET, IST Audio AVC
6V6GT	Output
6X4	Rectifier

POWER OUTPUT

Undistorted	1.5 Watts
Maximum	2.5 Watts
Plate load	5500 Ohms

LOUD SPEAKER

Type: Permanent magnet, .68 oz. Alnico 5

Size: 5 Inch

Voice coil impedance 3.2 Ohms

CHASSIS FEATURES

Automatic Volume Control

Built-in Loop—AM

Underwriters' Listed

Built-in Line Cord Antenna—FM

OPERATING CONTROLS

1. Left knob ON-OFF Sw and Volume
2. Right knob Tuning
3. Center knob Band Sw

PHYSICAL DIMENSIONS

Length	13 $\frac{7}{8}$ inches
Height	6 $\frac{5}{8}$ inches
Depth	7 $\frac{5}{8}$ inches

Colors are as follows:

Ivory, Willow Green, Sandalwood and Rosewood.

THE ANTENNA

AM - This receiver has a built-in loop which gives satisfactory reception in most locations. If the receiver is located some distance from a broadcasting station, or where the electrical interference is high, an outside antenna connected to the terminal marked AM on the antenna terminal strip will improve reception.

FM - A Built-in Line Cord Antenna is connected to the FM antenna. Terminals are provided on the antenna terminal strip to connect an outside FM antenna, they are labeled FM & G.

TECHNICAL INFORMATION

- AM** Tuning range — 540 Kc. to 1600 Kc. Intermediate Frequency 455 Kc. I. F. and R. F. measurements made at 500 milliwatts output — approximately 1.27 volts on a receiver type voltmeter connected across speaker voice coil. Approximate input for 500 MW output: I. F. 300 uv; R. F. with standard loop: at 600 Kc. 1200 uv/m; at 1000 Kc. 900 uv/m; at 1400 Kc. 800 uv/m.
- FM** Tuning range — 88 megacycles to 108 megacycles. Intermediate frequency 10.7 megacycles. I.F. and R.F. measurements made at 500 milliwatts output — approximately 1.27 volts on a rectifier type voltmeter connected across speaker voice coil. Approximate input for 500 MW output: I. F. 300 uv; R. F. "Absolute Measurements": 91 megacycles 100 uv; 105 megacycles, 100 uv.

ALIGNMENT PROCEDURE

Output meter connection Across speaker voice coil
 Output meter reading to indicate 500 MW 1.27 volts
 Generator Modulation 30%, 400 cycles
 Position of volume control Fully clockwise

Set dial pointer Horizontal, variable condenser closed
 Set band switch
To left for AM alignment, right for FM alignment

AM ALIGNMENT

Position of Variable	Generator Frequency	Dummy Ant.	Generator Connection (high)	Generator Connection Ground Lead	Adjust Trimmers In Order Shown For Max. Output	Trimmer Function
Open	455 Kc	.05 mfd.	Mixer Grid	Chassis	A1, A2, A3, A4,	I. F.
Open	1650 Kc		*Test Loop	Test Loop	A5	Oscillator
1400 Kc	1400 Kc		*Test Loop	Test Loop	A6	Antenna
**600 Kc	600 Kc		*Test Loop	Test Loop	Check Point	Antenna

* Connect generator lead to Standard Hazeltine Test Loop, Model 1150, placed two feet from the set loop, or three turns of wire about six inches in diameter, placed about one foot from the set loop. Or the generator can be connected with the high side lead to the AM antenna screw terminal and the ground lead to the chassis.
 **With a generator signal of 600 Kc, tune the set to the point where maximum output is obtained, which should be approximately 600 Kc on the dial. Adjust antenna section plates of variable for maximum output. The alignment procedure should be repeated in the original order for greatest accuracy. Always keep the output from the signal generator at its lowest possible value to make the A. V. C. action of the receiver ineffective.

FM ALIGNMENT

1. Turn band switch to FM, (right).
2. Connect (FM) I.F. generator to the second 6BA6 I.F. amp. grid, (lug No. 1) through a .01 uf mica dummy. Connect oscilloscope across volume control. With the I. F. generator tuned to 10.7 mc with 150 Kc deviation, and the same audio voltage used as horizontal sweep on the scope that is used to modulate the generator, adjust the ratio detector transformer slugs A7-A8 for the characteristic "S" curve (See Fig. 1), with maximum vertical height on the scope. After this adjustment the top slug of the ratio detector should not be moved during the rest of the alignment.

Use R.F. generator with 23 Kc deviation. With the variable condenser completely open and Signal Generator tuned to 108.5 Mc adjust oscillator trimmer A12 (small ceramic trimmer) for maximum reading on output meter.

Then tune receiver to low end of band (variable completely closed) and Signal Generator to 87.5 Mc. If the receiver does not tune to this frequency the FM oscillator coil L4 will either have to be squeezed together or lengthened to cover the band, (squeezing lowers and lengthening raises the frequency). Any change in the coil will have to be completed by the trimmer at the high end of the band.

3. Connect I.F. generator to mixer grid through .01 mica dummy. Using 23 Kc deviation at 10.7 Mc, adjust for maximum output. Maximum output may be indicated by maximum vertical height on the scope or maximum voltage on a standard output meter across the voice coil of the receiver. After the two I.F. transformers have been aligned the bottom slug A8 of the ratio detector should also be peaked.

5. With the same Signal Generator connections as per paragraph 4 tune Signal Generator and set to 105 Mc. Tune R. F. trimmer A13 for maximum output at the same time rock variable back and forth through the frequency. (Rocking is necessary because slight oscillator pulling causes erroneous maximum readings).

The characteristic "S" curve of the complete I. F. channel should be checked by applying a 10.7 Mc signal with 150 Kc deviation to the mixer grid and observing the "S" curve on the scope. It should not be very much different from that observed in step 2.

Tune Signal Generator and set to 90 Mc. Adjust R. F. coil L3 length for maximum output by squeezing or lengthening. Any change in the coil will have to be compensated at 105 Mc by the R. F. trimmer A13.

Connect R. F. (FM) generator (88 to 108Mc) to the antenna terminals through the standard 300 ohm dummy (150 ohm in each side of generator leads).

6. After Steps 4 and 5 are finished check calibration and band coverage. Steps 4 and 5 may have to be repeated if set is off calibration. Band coverage should be 87.5 Mc to 108.5 Mc. Sensitivity should be approximately 100 uv at 105 Mc, 98 Mc and 90 Mc.



FIG. 1.

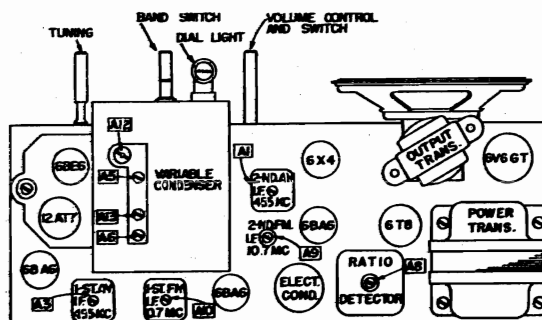

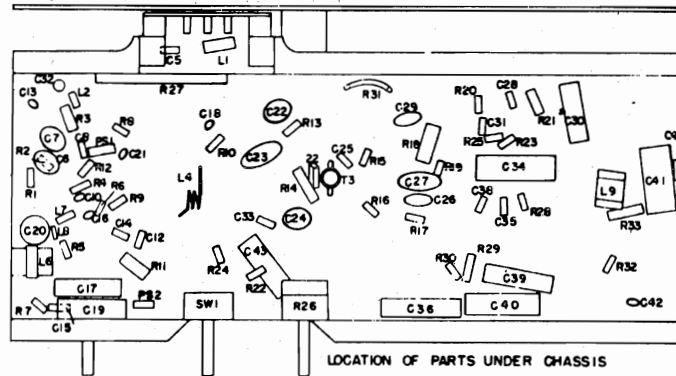

HOW TO ORDER PARTS

Replacement parts should be ordered by Arvin part number, description and model number of receiver from your Arvin Distributor. The Distributor will order direct from the factory, except in the case of tubes, which should be obtained through regular tube distribution channels.

PARTS PRICE LIST FOR 580TFM

Schematic Location	Part Number	Description	List Price	Schematic Location	Part Number	Description	List Price
L3	D24770	Antenna Loop Assembly	1.00		E23241-1	Crystal, Dial	1.00
	A23829-1	Cabinet, Rosewood	4.25		AC23302-1	Dial Plate Assembly [Rosewood]	.35
	A23829-2	Cabinet, Ivory	4.25		AC23302-2	Dial Plate Assembly [Ivory]	.35
	A23829-3	Cabinet, Willow Green	4.25		AC23302-3	Dial Plate Assembly [Willow Green]	.35
	A23829-4	Cabinet, Sandalwood	4.25		AC23302-4	Dial Plate Assembly [Sandalwood]	.35
L1	AA22648-1	Choke, High Frequency, 1.5uh	.30	L10	AA24772-1	Choke, R.F.	.50
L2	AA21445-1	Choke, High Frequency, 7.5uh	.50	C40	C20069-501	Capacitor, P.T., .0005uf, 600V	.20
L7	AA22597-1	Choke, High Frequency, 3uh	.30		A24464-2	Knob, Ivory	.30
L8	A21673	Choke, R.F. Iron Core, 14uh	.40		D23242	Pointer, Dial	.40
L9	C24308-1	Choke, Line Cord	.50	R1, R5,			
L4	A22593	Coil, R.F. FM	.10	R12, R22	C20060-105	Resistor, 1 megohm, 20% 1/4 W.	.10
L5	A22594	Coil, Oscillator, FM	.10	R2, R13,			
L6	AC22587-1	Coil, Oscillator, AM	.50	R17	C20060-680	Resistor, 68 ohms, 20% 1/4 W.	.10
C1, C2, C3,				R3	C20070-682	Resistor, 6.8K ohms, 10% 1 W.	.15
C4	D24773	Capacitor, Variable, 4 gang	4.15	R4	C20060-222	Resistor, 2200 ohms, 20% 1/4 W.	.10
C4A	A22724	Capacitor, Oscillator Trim. Cor. 5-25uuf	.80	R6, R9	C20060-103	Resistor, 10 K ohms, 20% 1/4 W.	.10
C5, C15	C20203-470	Capacitor, Ceramic, 47 uuf, 350 V.	.20	R7	C20060-223	Resistor, 22K ohms, 20% 1/4 W.	.10
C6, C20,				R8, R10,			
C22, C24,	A21674	Capacitor, Disc, 5Kuuf, 350 V.	.25	R15, R19	C20060-102	Resistor, 1K ohm, 20% 1/4 W.	.10
C26, C29				R11	C20070-822	Resistor, 8.2K ohms, 10% 1 W.	.15
C7, C23,	A22295	Capacitor, Disc. 10Kuuf, 350 V.	.25	R14	C20070-103	Resistor, 10K ohms, 10% 1 W.	.15
C27				R16, R24	C20060-104	Resistor, 100K ohms, 20% 1/4 W.	.10
C8, C12,				R18	C20070-332	Resistor, 3.3K ohms, 10% 1 W.	.15
C28, C31,				R20	C20061-181	Resistor, 180 ohms, 20% 1/4 W.	.10
C33, C38,				R21	C20120-393	Resistor, 39K ohms, 10% 1/4 W.	.10
C44	C20203-101	Capacitor, Ceramic, 100uuf, 350 V.	.20	R22	C20060-224	Resistor, 220K ohms, 20% 1/4 W.	.10
C9	C20205-20	Capacitor, Ceramic, 3.3uuf, 500 V.	.30	R25	C22381-153	Resistor, 15K ohms, 10% 1/2 W.	.10
C10, C13,				R27	A24774	Resistor, 1000 ohms, 10 W. Wire	.55
C16, C18,				R28	C20060-106	Resistor, 10 megohms, 20% 1/4 W.	.10
C21, C32,				R29	C20060-334	Resistor, 330K ohms, 20% 1/4 W.	.10
C42	A23078	Capacitor, Disc, 1Kuuf, 600 V.	.20	R30	C20060-154	Resistor, 150K ohms, 20% 1/4 W.	.10
C11	A20238-3	Capacitor, Ceramic, 1.5uuf, gimmie	.10	R31	A23933	Resistor, 120 ohms, 1 W. Wire	.15
C14	C20205-5	Capacitor, Ceramic, 50uuf, 500 V., N750	.20	R32	C20060-474	Resistor, 470K ohms, 20% 1/4 W.	.10
C17, C36	C20069-103	Capacitor, P.T., .01uuf, 400 V.	.20	R33	C20070-271	Resistor, 270 ohms, 10% 1 W.	.15
C19	C20067-503	Capacitor, P.T., .05uuf, 200 V.	.20		A22957	Shaft, Tuning	.15
C25	C20203-150	Capacitor, Ceramic, 15uuf, 350 V.	.20	SPR	C22760	Speaker, 5" P.M.	3.45
C30	C20069-302	Capacitor, P.T., .003uuf, 600 V.	.20		A19133	Spring, Dial Cord	10 for .25
C34	A22659	Capacitor, Electrolytic, 4 uf, 25 V.	.65	P.S. 2	AA22334-1	Suppressor Assembly Parasitic, AM	.20
C35	C20203-221	Capacitor, Ceramic, 220uuf, 350 V.	.20	P.S. 1	AA22345-1	Suppressor Assembly Parasitic, FM	.20
C37A, B, C	A22806	Capacitor, Electrolytic, 20-20-40uf, 250 V.	1.65	SW-1	C22961	Switch, Band, FM-AM	.80
C39	C20068-203	Capacitor, P.T., .02uf, 400 V.	.20	T2	C22352	Transformer, I.F. 455Kc., AM	1.35
C41	A22602	Capacitor, Electrolytic, 10uf, 25V.	.65	T1	C22590	Transformer, 1st I.F. 10.7Mc, FM	1.35
C43	C20249-103	Capacitor, Molded, .01uf, 400 V.	.20	T3	AC22967-1	Transformer, 2nd I.F., 10.7Mc, FM	.75
R26, SW-2	C22963	Control, Volume & Switch, 500K ohms	.80	T4	C24771	Transformer, I.F. 455Kc, AM	1.35
	A19132	Cord, Dial Drive	10 for .25	T5	AD22592-1	Transformer, Ratio Detector	1.80
	B20138-17	Cord, Power, with Plug	.45	T6	AC22995	Transformer, Output	1.75
	C23299	Cover, Cabinet, Rear	.25	T7	D22959	Transformer, Power	4.20

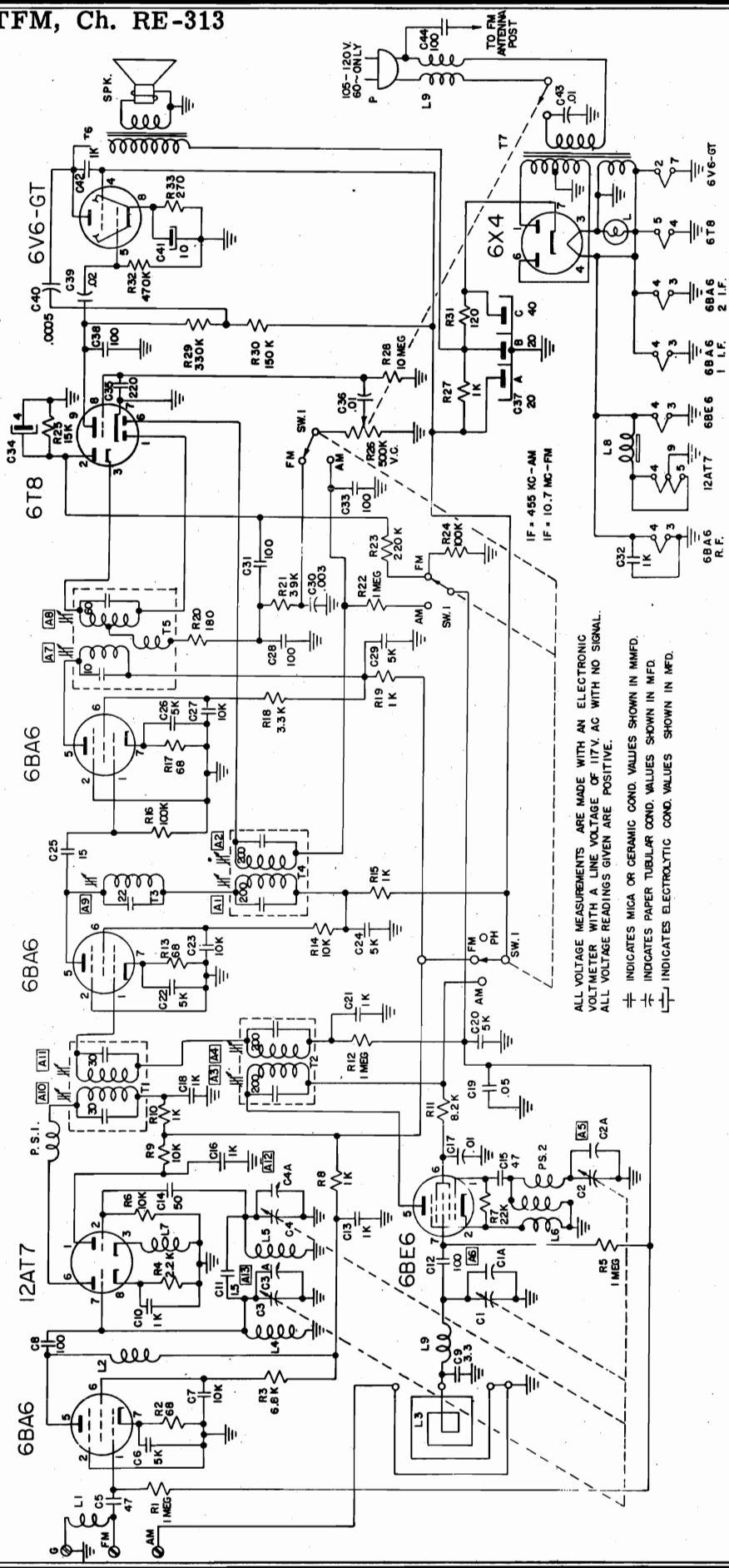

ALL VOLTAGE MEASUREMENTS ARE MADE WITH AN ELECTRONIC VOLTMETER WITH A LINE VOLTAGE OF 117V. AC WITH NO SIGNAL. ALL VOLTAGE READINGS GIVEN ARE POSITIVE.

⊃ INDICATES MICA OR CERAMIC COND. VALUES SHOWN IN MMFD.

⊃ INDICATES PAPER TUBULAR COND. VALUES SHOWN IN MFD.

⊃ INDICATES ELECTROLYTIC COND. VALUES SHOWN IN MFD.

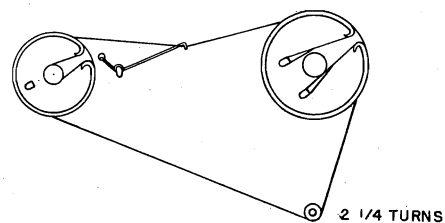
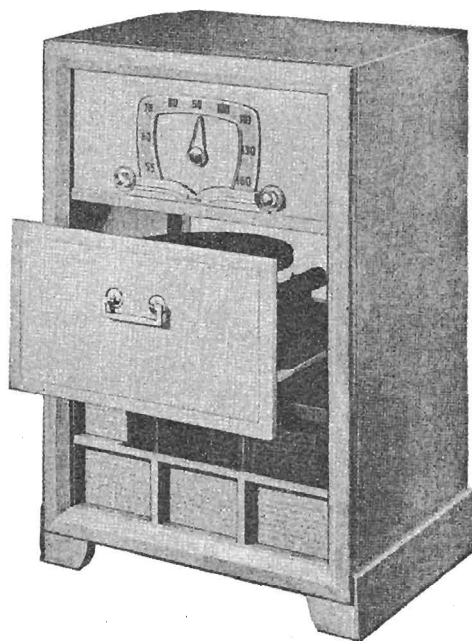

SPECIFICATIONS

FREQUENCY RANGE

Broadcast 540-1600 kc
 IF 455 kc

TUBES AND FUNCTIONS

6BE6 Mixer-oscillator
 6BA6 IF Amp.
 6AV6 DET-AVC AF Amp.
 6V6 Output
 5Y3 Rectifier

POWER OUTPUT

Undistorted 3.5 Watts
 Maximum 4.5 Watts
 Plate load 5000 Ohms

LOUD SPEAKER

Type: Permanent magnet, 2.15 oz. Alnico 5
 Size: 8 Inch
 Voice coil impedance 3.2 Ohms

CHASSIS FEATURES

Automatic Volume Control
 Built-in Loop
 Underwriters' Listed

OPERATING CONTROLS

1. Left knob..... ON-OFF, Volume and Tone
 2. Right knob Tuning and Phono-Radio

PHYSICAL DIMENSIONS

Length 22 inches
 Height 34 inches
 Depth 16 inches

Models 554CCM and 554 CCB have the same radio chassis and changer. They differ only in cabinet trim, and knobs; 554CCM with Mahogany Cabinet and 554CCB with Blonde Cabinet.

ALIGNMENT PROCEDURE

PRELIMINARY:

Output meter connection..... Across loudspeaker voice coil
 Output meter reading to indicate .5 W (standard output)..... 1.26 volts
 Connection of generator ground lead..... Chassis
 Generator modulation..... 30% 400 cycles
 Position of volume and tone control..... Fully clockwise
 Position of dial pointer with variable fully closed..... To left

1. Connect signal generator lead through a .05 uf. condenser to converter grid. Open tuning condenser. Set signal generator to 455 Kc. Tune I. F. Trimmers A1, A2, A3, and A4 for maximum output.
2. Close tuning condenser and set pointer to left. Open tuning condenser. Connect signal generator to test loop or to blue lead on set loop. Set signal generator to 1650 Kc. Tune A5 trimmer on oscillator section of tuning condenser for maximum output.
3. Set signal generator to 1400 Kc. Adjust tuning shaft until maximum output is obtained. Tune antenna trimmer A6 on tuning condenser for greatest output. Reset tuning shaft until output is again maximum. Retune antenna trimmer. Repeat this cycle of operations at 1400 Kc. until no further increase of output can be obtained. Keep generator output at a low value to prevent detuning by A. V. C. action.
4. Set signal generator to 600 Kc. Adjust tuning shaft for maximum output. Adjust tuning condenser plates for maximum output if necessary.

Approximate sensitivities with 117 V. AC line voltage and .5 W. output across voice coil, should be: Antenna lead 600 Kc.—600 uv/m., 1000 Kc.—400 uv/m., 1400 Kc.—300 uv/m.

MODELS 554CCB, 554CCM, Ch. RE-306

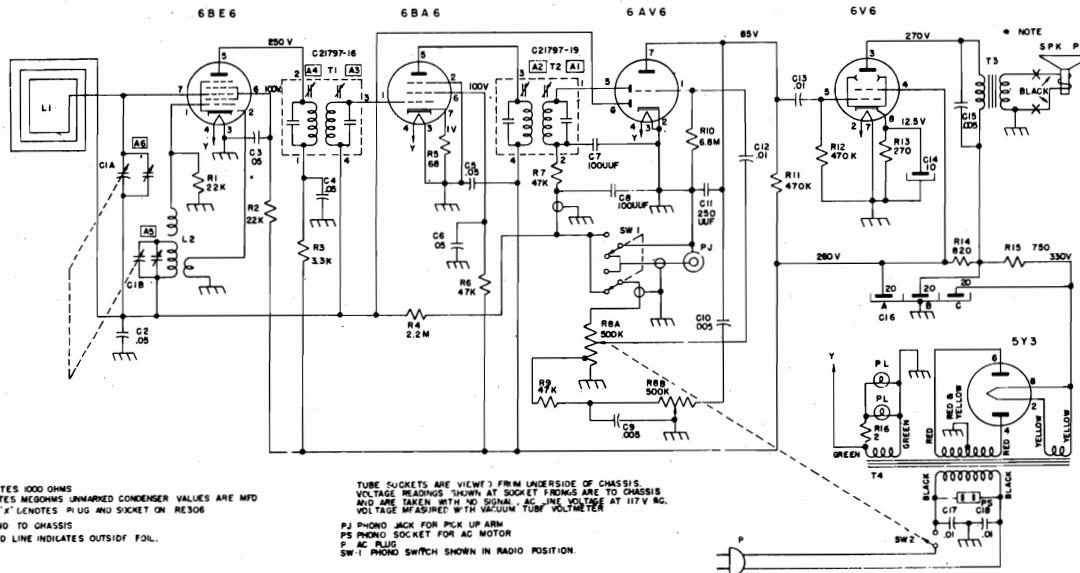

* INDICATES 500 OHMS
 M INDICATES MEGOHMS UNMARKED CONDENSER VALUES ARE MFD
 NOTE 'X' DENOTES PI US AND SOCKET ON RES306
 † GROUND TO CHASSIS
 ‡ CURVED LINE INDICATES OUTSIDE FOIL.

TUBE SOCKETS ARE VIEWED FROM UNDERSIDE OF CHASSIS.
 VOLTAGE READINGS SHOWN AT SOCKET FRINGS ARE TO CHASSIS
 AND ARE TAKEN WITH NO SIGNAL. AC LINE VOLTAGE AT 117 V AC.
 VOLTAGE MEASURED WITH VACUUM TUBE VOLTMETER.

P.J. PHONO JACK FOR PICK UP ARM
 P.S. PHONO SOCKET FOR AC MOTOR
 P. AC PLUS
 SW-1 PHONO SWITCH SHOWN IN RADIO POSITION.

TUBE LAYOUT

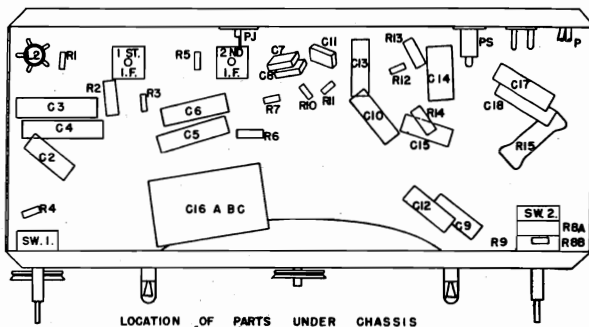
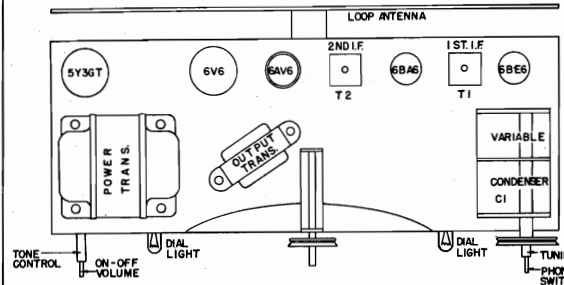

PARTS PRICE LIST FOR NO. 554CCM AND 554CCB

Schematic Loc.	Number Part	Description	Price	Schematic Loc.	Number Part	Description	Price
L1	D24777	Antenna Loop Assembly	1.50	E24702-1	Escutcheon, Decorative (Mahogany)	2.00	
	R24720-3	Cabinet, Mahogany	72.00	E24702-2	Escutcheon, Decorative (Blonde)	2.00	
	R24720-4	Cabinet, Blonde	80.00	A24442-1	Knob, Volume, Radio-Phono	.20	
C1A, B	C24305	Capacitor, Variable, 2 gang with Trimmers	2.10	A24443-1	Knob, Tone, Tuning	.20	
C2	C20067-503	Capacitor, .05 mf, 200 V, P.T.	.20	A19351	Lamp, Dial, Mazda No. 47	.20	
C3, C4, C5, C6, C7, C8	C20068-503	Capacitor, .05 mf, 400 V, P.T.	.20	B20138-15	Line Cord	.75	
C9	C20065-101	Capacitor, 100 mmf, 500 V, Mica	.30	AA24766-1	Pointer, Shaft & Bracket Assy.	.30	
C10	C20067-502	Capacitor, .005 mf, 500 V, P.T.	.20	R1	C20060-223 Resistor, 22K ohm, 20%, 1/4 W.	.10	
C11	C20068-302	Capacitor, .003 mf, 400 V, P.T.	.20	R2	C20302-223 Resistor, 22K ohm, 10%, 2 W.	.15	
C12, C13	C20065-251	Capacitor, 250 mmf, 500 V, Mica	.20	R3	C20060-332 Resistor, 3.3K ohm, 20%, 1/4 W.	.10	
C14	C20068-103	Capacitor, .01 mfd, 400 V, P.T.	.20	R4	C20060-225 Resistor, 2.2 megohm, 20%, 1/4 W.	.10	
C15	A22602	Capacitor, 10 mfd, 25 V. Electrolytic	.65	R5	C20060-680 Resistor, 68 ohm, 20%, 1/4 W.	.10	
C16A, B, C	C20069-302	Capacitor, .003 mfd, 600 V. P.T.	.20	R6	C20070-473 Resistor, 47K ohm, 10%, 1 W.	.15	
C17, C18	C24415	Capacitor, 20-20-20 mfd, 450 V. Electrolytic	1.75	R7, R9	C20060-473 Resistor, 47K ohm, 20%, 1/4 W.	.10	
	E23593	Changer, 3-speed Record Assembly (See VM—Model 950)	.50	R10	C20060-685 Resistor, 6.8 megohm, 20%, 1/4 W.	.10	
L2	AC24482-1	Coil, Oscillator	.60	R11, R12	C20060-474 Resistor, 470K ohm, 20%, 1/4 W.	.10	
R8A, B	C24535	Control, Volume & Tone, Dual 500K-500K ohms	1.00	R13	C20070-271 Resistor, 270 ohm, 10%, 1 W.	.15	
	C24726	Cover, Cabinet, Rear	.75		or		
	C23578	Cover, Record Changer Bottom	.10	R14	A24891 Resistor, 270 ohm, 10% 1 W. Wire	.15	
	C24449	Dial, Pointer	.30	R15	C20070-821 Resistor, 820 ohm, 10%, 1 W.	.15	
	E24447	Dial, Crystal	2.75	R16	C23970-14 Resistor, 750 ohm, 10%, 5 W. Wire	.40	
	D24803-1	Dial, Crystal Background (Mahogany)	.25		A24761 Resistor, 2 ohm, 10%, 1/2 W. Wire	.10	
	D24803-2	Dial, Crystal Background (Blonde)	.25		A24767-2 Socket, Dial Lamp	.10	
					A19579 Socket, Speaker	.10	
					A19551 Socket, AC Phono Motor	.25	
				SPK	AD24763-1 Speaker, Assembly 8" P.M.	7.85	
					C24438 Switch, Phono-Radio	.75	
				T1	C21797-16 Transformer, 1st I.F.	1.20	
				T2	C21797-19 Transformer, 2nd I.F.	1.25	
				T3	C24776-1 Transformer, Output	2.25	

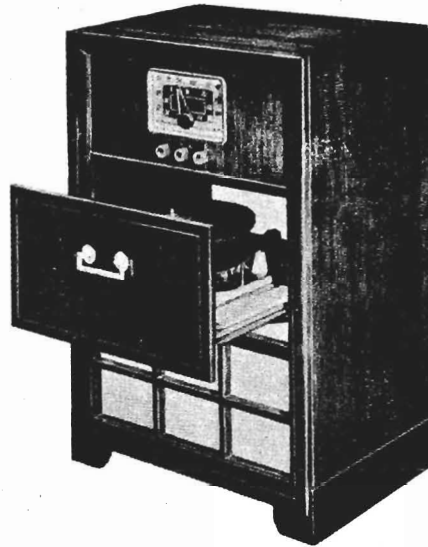

SPECIFICATIONS

FREQUENCY RANGE

Broadcast (AM)	540-1600 kc
IF	455 kc
FM	88-108 mc
IF	10.7 mc

TUBES AND FUNCTIONS

6BA6	FM R. F. Amp.
12AT7	FM Converter
6BE6	AM Converter
6BA6	AM-FM-IF Amp.
6BA6	FM, IF Amp.
6T8	FM-AM DET, 1ST Audio AVC
6V6GT	Output
6X4	Rectifier

POWER OUTPUT

Undistorted	1.5 Watts
Maximum	2.5 Watts
Plate load	2000 Ohms

LOUD SPEAKER

Type: Permanent magnet, 1.47 oz. Alnico 5	
Size: 8 Inch	
Voice coil impedance	3.2 Ohms

CHASSIS FEATURES

Automatic Volume Control
Built-in Loop
Underwriters' Listed

OPERATING CONTROLS

1. Left knob	ON-OFF Sw and Volume
2. Right knob	Tuning
3. Center knob	Program Sw

PHYSICAL DIMENSIONS

Width	22 inches
Height	34 inches
Depth	16 inches

Models 582CFM, and 582CFB have the same Chassis, they differ only in Cabinet, trim and knobs.

THE ANTENNA

AM - This receiver has a built-in loop which gives satisfactory reception in most locations. If the receiver is located some distance from a broadcasting station, or where the electrical interference is high, an outside antenna connected to the terminal marked AM on the antenna terminal strip will improve reception.

FM - An 8' length of wire is connected to the FM antenna terminal for an indoor FM antenna. Terminals are provided on the antenna terminal strip to connect an outside FM antenna, they are labeled FM & G.

TECHNICAL INFORMATION

AM Tuning range — 540 Kc. to 1600 Kc. Intermediate Frequency - 455 Kc. I. F. and R. F. measurements made at 500 milliwatts output — approximately 1.27 volts on a receiver type voltmeter connected across speaker voice coil. Approximate input for 500 MW output: I. F. 300 uv; R. F. with standard loop: at 600 Kc. 1200 uv/m; at 1000 Kc. 900 uv/m; at 1400 Kc. 800 uv/m.

FM Tuning range — 88 megacycles to 108 megacycles. Intermediate frequency 10.7 megacycles .I.F. and R.F. measurements made at 500 milliwatts output — approximately 1.27 volts on a rectifier type voltmeter connected across speaker voice coil. Approximate input for 500 MW output: I. F. 300 uv; R. F. "Absolute Measurements": 91 megacycles 100 uv; 105 megacycles, 100 uv.

MODELS 582CFB, 582CFM, Ch. RE-310

ALIGNMENT PROCEDURE

Output meter connection Across speaker voice coil Set dial pointer Horizontal, variable condenser closed
 Output meter reading to indicate 500 MW 1.27 volts Set band switch
 Generator Modulation 30%, 400 cycles To left for AM alignment, right for FM alignment
 Position of volume control Fully clockwise

AM ALIGNMENT

Position of Variable	Generator Frequency	Dummy An.	Generator Connection (high)	Generator Connection Ground Lead	Adjust Trimmers In Order Shown For Max. Output	Trimmer Function
Open	455 Kc	.05 mfd.	Mixer Grid	Chassis	A1, A2, A3, A4,	I. F.
Open	1650 Kc		*Test Loop	Test Loop	A5	Oscillator
1400 Kc	1400 Kc		*Test Loop	Test Loop	A6	Antenna
**600 Kc	600 Kc		*Test Loop	Test Loop	Check Point	Antenna

* Connect generator lead to Standard Hazeltine Test Loop, Model 1150, placed two feet from the set loop, or three turns of wire about six inches in diameter, placed about one foot from the set loop. Or the generator can be connected with the high side lead to the AM antenna screw terminal and the ground lead to the chassis.
 **With a generator signal of 600 Kc, tune the set to the point where maximum output is obtained, which should be approximately 600 Kc on the dial. Adjust antenna section plates of variable for maximum output. The alignment procedure should be repeated in the original order for greatest accuracy. Always keep the output from the signal generator at its lowest possible value to make the A. V. C. action of the receiver ineffective.

FM ALIGNMENT

1. Turn band switch to FM, (right).
2. Connect (FM) I. F. generator to the second 6BA6 I. F. amp. grid, (lug No. 1) through a .01 uf mica dummy. Connect oscilloscope across volume control. With the I. F. generator tuned to 10.7 mc with 150 Kc deviation, and the same audio voltage used as horizontal sweep on the scope that is used to modulate the generator, adjust the ratio detector transformer slugs A7-A8 for the characteristic "S" curve (See Fig. 1), with maximum vertical height on the scope. After this adjustment the top slug of the ratio detector should not be moved during the rest of the alignment.
3. Connect I. F. generator to mixer grid through .01 mica dummy. Using 23 Kc deviation at 10.7 Mc, adjust for maximum output. Maximum output may be indicated by maximum vertical height on the scope or maximum voltage on a standard output meter across the voice coil of the receiver. After the two I. F. transformers have been aligned the bottom slug A8 of the ratio detector should also be peaked.
 The characteristic "S" curve of the complete I. F. channel should be checked by applying a 10.7 Mc signal with 150 Kc deviation to the mixer grid and observing the "S" curve on the scope. It should not be very much different from that observed in step 2.
4. Connect R. F. (FM) generator (88 to 108Mc) to the antenna terminals through the standard 300 ohm dummy (150 ohm in each side of generator leads).

Use R. F. generator with 23 Kc deviation. With the variable condenser completely open and Signal Generator tuned to 108.5 Mc adjust oscillator trimmer A12 (small ceramic trimmer) for maximum reading on output meter.

Then tune receiver to low end of band (variable completely closed) and Signal Generator to 87.5 Mc. If the receiver does not tune to this frequency the FM oscillator coil L4 will either have to be squeezed together or lengthened to cover the band, (squeezing lowers and lengthening raises the frequency). Any change in the coil will have to be completed by the trimmer at the high end of the band.

5. With the same Signal Generator connections as per paragraph 4 tune Signal Generator and set to 105 Mc. Tune R. F. trimmer A13 for maximum output at the same time rock variable back and forth through the frequency. (Rocking is necessary because slight oscillator pulling causes erroneous maximum readings).
 Tune Signal Generator and set to 90 Mc. Adjust R. F. coil L3 length for maximum output by squeezing or lengthening. Any change in the coil will have to be compensated at 105 Mc by the R. F. trimmer A13.
6. After Steps 4 and 5 are finished check calibration and band coverage. Steps 4 and 5 may have to be repeated if set is off calibration. Band coverage should be 87.5 Mc to 108.5 Mc. Sensitivity should be approximately 100 uv at 105 Mc, 98 Mc and 90 Mc.

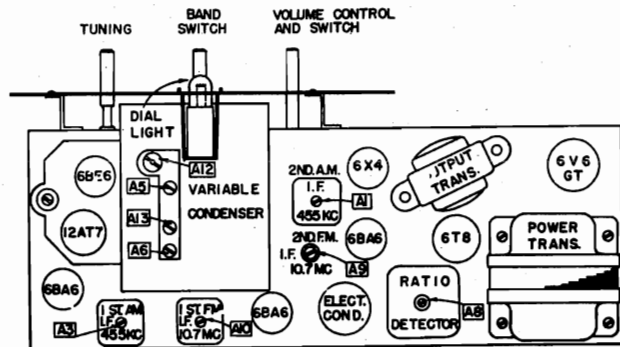

MODELS 582CFB, 582CFM, Ch. RE-310

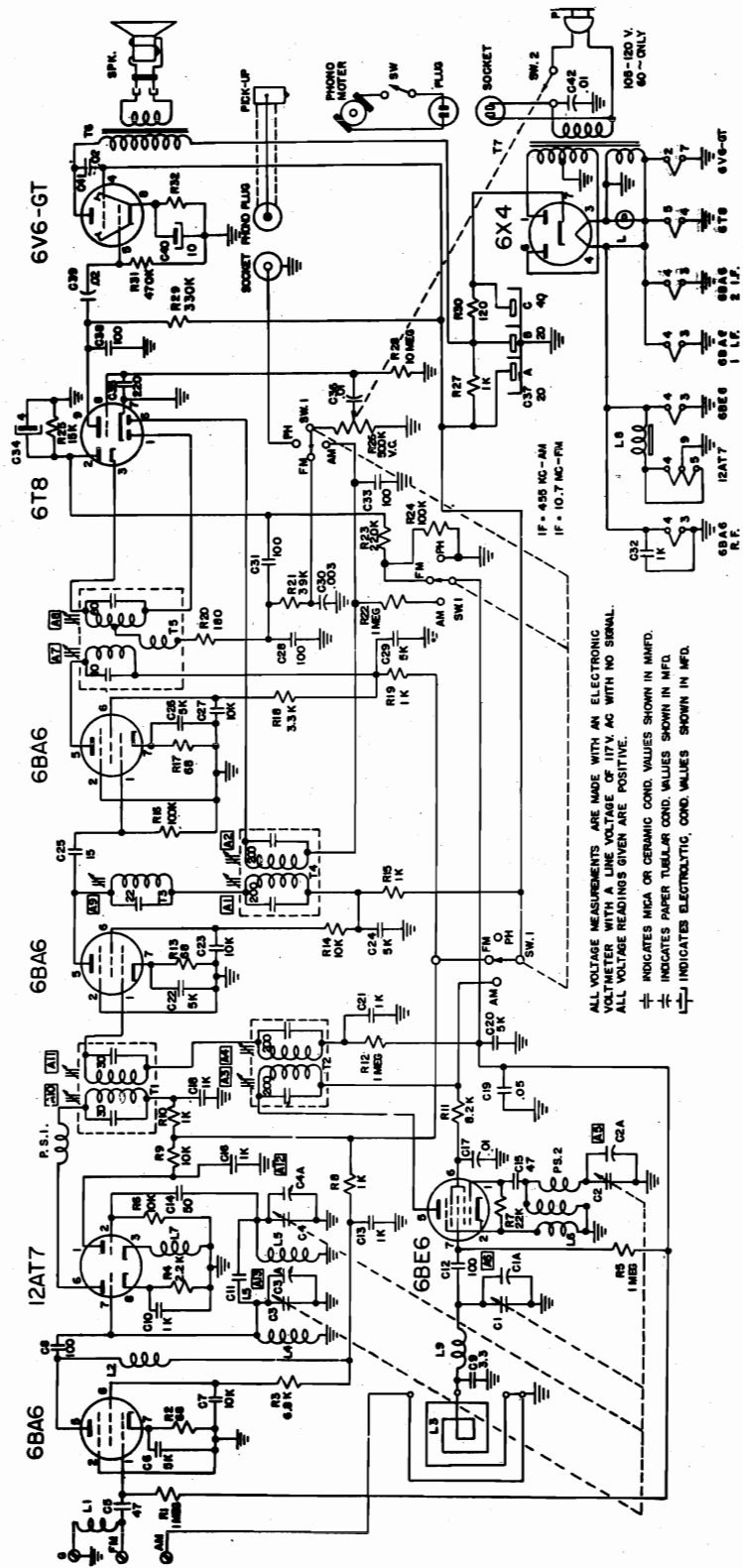

ALL VOLTAGE MEASUREMENTS ARE MADE WITH AN ELECTRONIC
VOLT METER WITH A LINE VOLTAGE OF 117V. AC WITH NO SIGNAL.
ALL VOLTAGE READINGS GIVEN ARE POSITIVE.
= INDICATES MICA OR CERAMIC COND. VALUES SHOWN IN MAFD.
= INDICATES PAPER TUBULAR COND. VALUES SHOWN IN MFD.
= INDICATES ELECTROLYTIC COND. VALUES SHOWN IN MFD.

MODELS 582CFB, 582CFM, Ch. RE-310

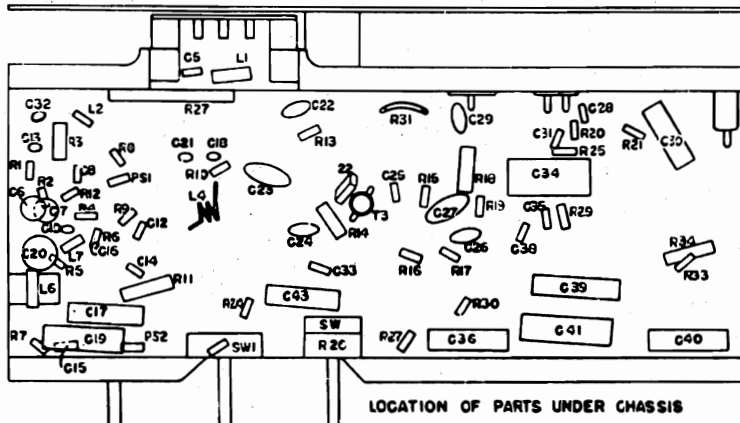

HOW TO ORDER PARTS

Replacement parts should be ordered by Arvin part number, description and model number of instrument from your Arvin Distributor.

Replacement parts for the V-M Changer must be obtained direct from the V-M Corporation, Benton Harbor, Michigan.

PARTS PRICE LIST FOR 582-CFM & 582-CFB, RE-310

Schematic Location	Part Number	Description	List Price	Schematic Location	Part Number	Description	List Price
	D24770	Antenna Loop Assembly	1.00		A24464	Knobs, Ph-AM-FM [Mahogany]	.20
	B22953	Bracket, Antenna Loop Mounting	.10		A24464-4	Knob, Tuning, On-Off, PH-AM-FM [Blonde]	.20
	C24724	Bracket, Dial [2 used]	.10		A24464-3	Knob, Tuning, On-Off, PH-AM-FM [Mahogany]	.20
	R24692-1	Cabinet, Mahogany [with Carton]	72.00		A19351	Lamp, Dial, Mazda No. 47	.20
	R24692-2	Cabinet, Blonde [with Carton]	80.00		C20138-17	Line Cord & Plug	.45
C1, C2, C3, C4	D24773	Capacitor, Variable, 4-gang	4.15	PS-1	AA22345-1	Parasitic Suppressor FM	.20
C4A	A22724	Capacitor, FM Oscillator Trimmer, 5-25uuf	.80	PSO2	AA22334-1	Parasitic Suppressor AM	.20
C11	A20238-3	Capacitor, 1.5uuf, 350V, Gimmick	.10	R3,	C20070-682	Resistor, 6.8K ohms, 10%, 1 W.	.15
C25	C20203-150	Capacitor, 15uuf, 350V, Ceramic	.20	R2, R13, R17	C20060-680	Resistor, 68 ohms, 20%, 1/2 W.	.10
C5, C15	C20203-470	Capacitor, 47uuf, 350V, Ceramic	.20	R31	A23933	Resistor, 120 ohms, 10%, 1 W.	.15
C14	C20205-5	Capacitor, 50uuf, 500V., Ceramic	.20	R20	C20060-181	Resistor, 180 ohms, 10%, 1/2 W.	.10
C8, C12, C28, C33, C31, C38	C20203-101	Capacitor, 100uuf, 350V., Ceramic	.20	R34	C20070-271	Resistor, 270 ohms, 10%, 1 W.	.15
C35	C20203-221	Capacitor, 220uuf, 350V., Ceramic	.20	R8, R10, R15, R19	C20060-102	Resistor, 1K ohms, 20%, 1/2 W.	.10
C10, C13, C16, C18, C21, C32	C23078	Capacitor, 1000uuf, 350V., Ceramic	.20	R4	C20060-222	Resistor, 2.2K ohms, 20%, 1/2 W.	.10
C30	C20069-302	Capacitor, .003 mfd., 600V., Paper	.20	R18	C20070-332	Resistor, 3.3K ohms, 10%, 1 W.	.15
C6, C20, C22, C24, C26, C29	A21674	Capacitor, 5000uuf, 350V., Disc Ceramic	.25	R11	C20070-822	Resistor, 8.2K ohms, 10%, 1 W.	.15
C7, C23, C27	A22295	Capacitor, 10,000uuf, 350V., Disc Ceramic	.25	R14	C20070-103	Resistor, 10K ohms, 10%, 1 W.	.15
C17, C36, C40	C20068-103	Capacitor, .01 mfd., 400V., Paper	.20	R25	C22381-153	Resistor, 15K ohms, 10%, 1/2 W.	.10
C42	C20249-103	Capacitor, .01 mfd., 400V., Phenolic	.20	R7	C20060-223	Resistor, 22K ohms, 20%, 1/2 W.	.10
C9	C20205-20	Capacitor, Ceramic, 3.3uuf, +.05 mmf, 500V.	.30	R6, R9	C20060-103	Resistor, 10K ohms, 20%, 1/2 W.	.10
C39	C20068-203	Capacitor, .02 mfd., 400V., Paper	.20	R21	C20120-393	Resistor, 39K ohms, 20%, 1/2 W.	.10
C19, C41	C20067-503	Capacitor, .05 mfd., 200V., Paper	.20	R28	A24774	Resistor, 1000 ohms, 10 W. Wire	.55
C34	A22659	Capacitor, 4 mfd., 25V., Electrolytic	.65	R16, R24	C20060-104	Resistor, 100K ohms, 20%, 1/2 W.	.10
C37A, B, C	A22806	Capacitor, 20-20-40 mfd., 250V., Electrolytic	1.65	R23	C20060-224	Resistor, 220K ohms, 20%, 1/2 W.	.10
L1	E23593-1	Changer, 3-speed Record [See VN Bulletin]		R30	C20060-334	Resistor, 330K ohms, 20%, 1/2 W.	.10
L7	AA22648-1	Choke, 1.5 uh	.30	R32	C20060-474	Resistor, 470K ohms, 20%, 1/2 W.	.10
L2	AA22597-1	Choke, 3 uh	.30	R1, R5, R12, R22	C20060-105	Resistor, 1 megohm, 20%, 1/2 W.	.10
L8	AA21445-1	Choke, 7.5 uh	.50	R29	C20060-106	Resistor, 10 megohms, 20%, 1/2 W.	.10
L6	A21673	Choke, 14 uh, Iron Core	.40	R27	C20060-681	Resistor, 680 ohms, 20%, 1/4 W.	.10
L5	AC22587-1	Coil, Oscillator, AM	.50	A19551	Socket, AC, Phono Motor	.25	
L4	A22594	Coil, Oscillator, FM	.10	A24345-1	Socket, Dial Lamp	.25	
R26	A22593	Coil, RF, FM	.10	A19552	Socket, Phono Pickup	.10	
	C22963	Control, Volume & Switch, 500K ohms	.80	A19579	Socket, Speaker	.10	
	C24726	Cover, Cabinet Rear	.06	AD23693-1	Speaker Assy. 8" PM with Cable & Plug	4.00	
	C23578	Cover, Record Changer Bottom	.15	A19133	Spring, Dial Cord	10 for .25	
	A24449	Dial Pointer [Mahogany]	.30	C23485	Switch, Band	.80	
	A24449	Dial Pointer [Blonde]	.30	A22960	Terminal Strip, Antenna	.10	
	C24709	Dial Scale [Mahogany]	.85	C22590	Transformer, I.F., 1st F.M. [10.7 Mc]	1.35	
	C24709	Dial Scale [Blonde]	.85	C22352	Transformer, I.F., AM [455Kc]	1.35	
	C24723	Escutcheon & Crystal	2.10	T3	AC22967-1	Transformer, I.F., 2nd FM [10.7 Mc]	.75
				T6	AC23669-1	Transformer, Output	1.75
				T7	D22959	Transformer, Power	4.20
				T5	AD22592-1	Transformer, Ratio Detector	1.80
					A22957	Tuning Shaft	.15

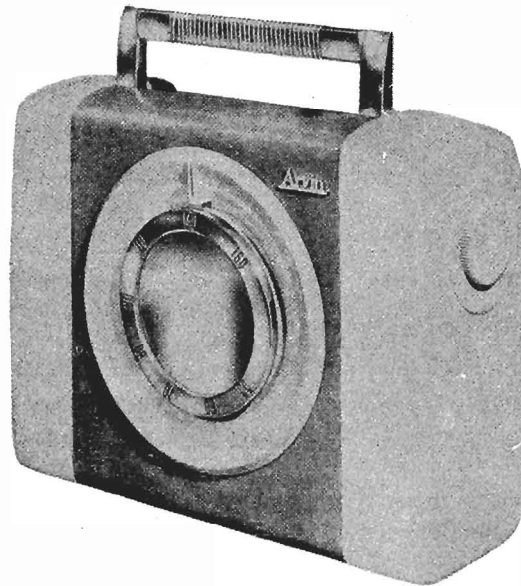

SPECIFICATIONS

FREQUENCY RANGE

Broadcast 540-1600 Kc
 IF 455 Kc

POWER OUTPUT

Maximum2 watt
 Undistorted16 watt
 Speaker Size 4 inch
 Voice Coil Impedance 3.2 ohms

TUBES AND FUNCTIONS

1T4 RF Amp.
 1R5 Converter
 1T4 IF Amp.
 1U5 Audio Amp. Detector
 3V4 Audio Output

CHASSIS FEATURES

Automatic Volume Control
 Iron Core Rod Antenna

CONTROLS

Left knob On-Off Sw. and Volume
 Right Knob Tuning

POWER SUPPLY

"B" 90 Volts 2 No. 455 Ever Ready or Equal
 "A" 9 Volts Six 1½ volt size "C" Flashlight Cells
 Or 115 Volts A.C. or D.C.

PHYSICAL DIMENSIONS

Width 11 inches
 Height 9 inches
 Depth 4 inches

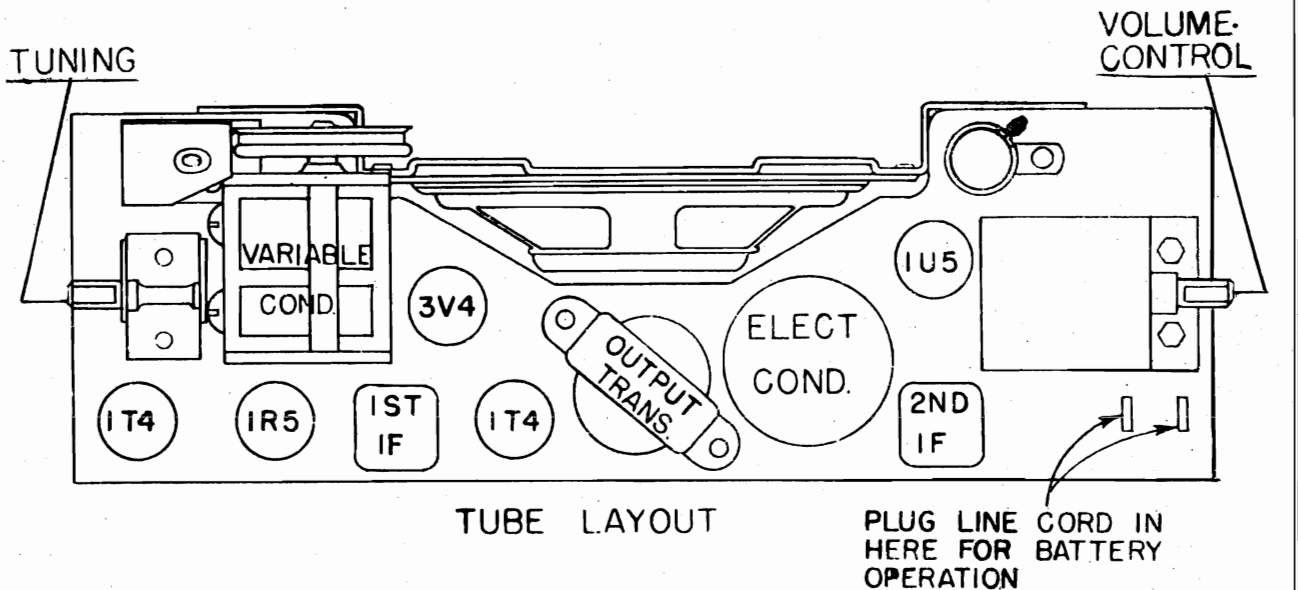

ALIGNMENT

- A. Connect to 117 V. A.C. line and turn set on with volume control at full volume.
- B. With variable condenser closed set pointer to end mark on dial back.
- C. Connect signal generator high side through .05 uf or larger condenser to Pin 6 on 1R5 tube.
- D. Open variable condenser.

E. With signal generator set at 455KC, increase output of generator until output is heard in speaker. Adjust all I.F. trimmers until maximum output meter reading is obtained, reducing signal generator output as adjustment progresses so that final adjustment is made with lowest input consistent with good signal to noise ratio.

NOTE: After I.F. alignment, the set must be provided with a bottom cover, or test jig which is the equivalent of the bottom cover, and the rest of the R.F. alignment carried out with this in place.

F. With signal generator at 455 KC and connected to a radiating loop, adjust R.F. transformer coupling condenser until output meter reading is a minimum. Final adjustment is to be made with high signal input so that an accurate adjustment can be made.

G. With signal generator connected to radiating loop and set to 1650 KC adjust oscillator trimmer on variable condenser until output is maximum. Variable condenser is to be fully opened during adjustment.

H. Set signal generator to 1400 KC and rotate variable condenser until output is maximum. Adjust R.F. trimmer on variable condenser until output increases to a new maximum. Rotate variable condenser slightly to obtain another maximum output. Re-adjust trimmer until output is again a maximum. Repeat this cycle until no further increase in output can be obtained. Final adjustment to be made with signal generator output at sensitivity limit given below or lower.

I. Set signal generator to 1000 KC and tune radio to maximum output. Read sensitivity. Adjust R.F. section of variable blades for maximum output.

J. Set signal generator to 600 KC and proceed as in I. above.

K. Set signal generator to 540 KC and make sure that radio will tune to maximum output slightly before variable condenser is fully closed.

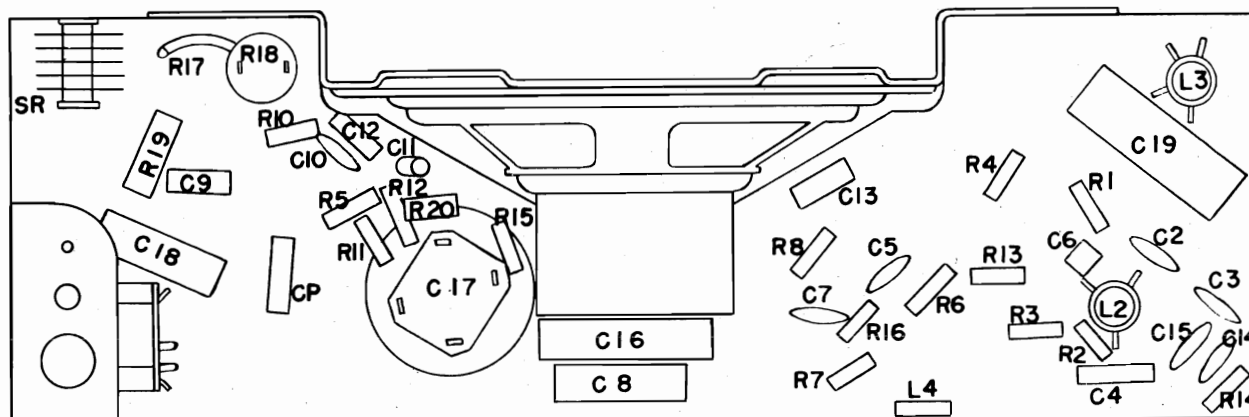

LOCATION OF PARTS UNDER CHASSIS

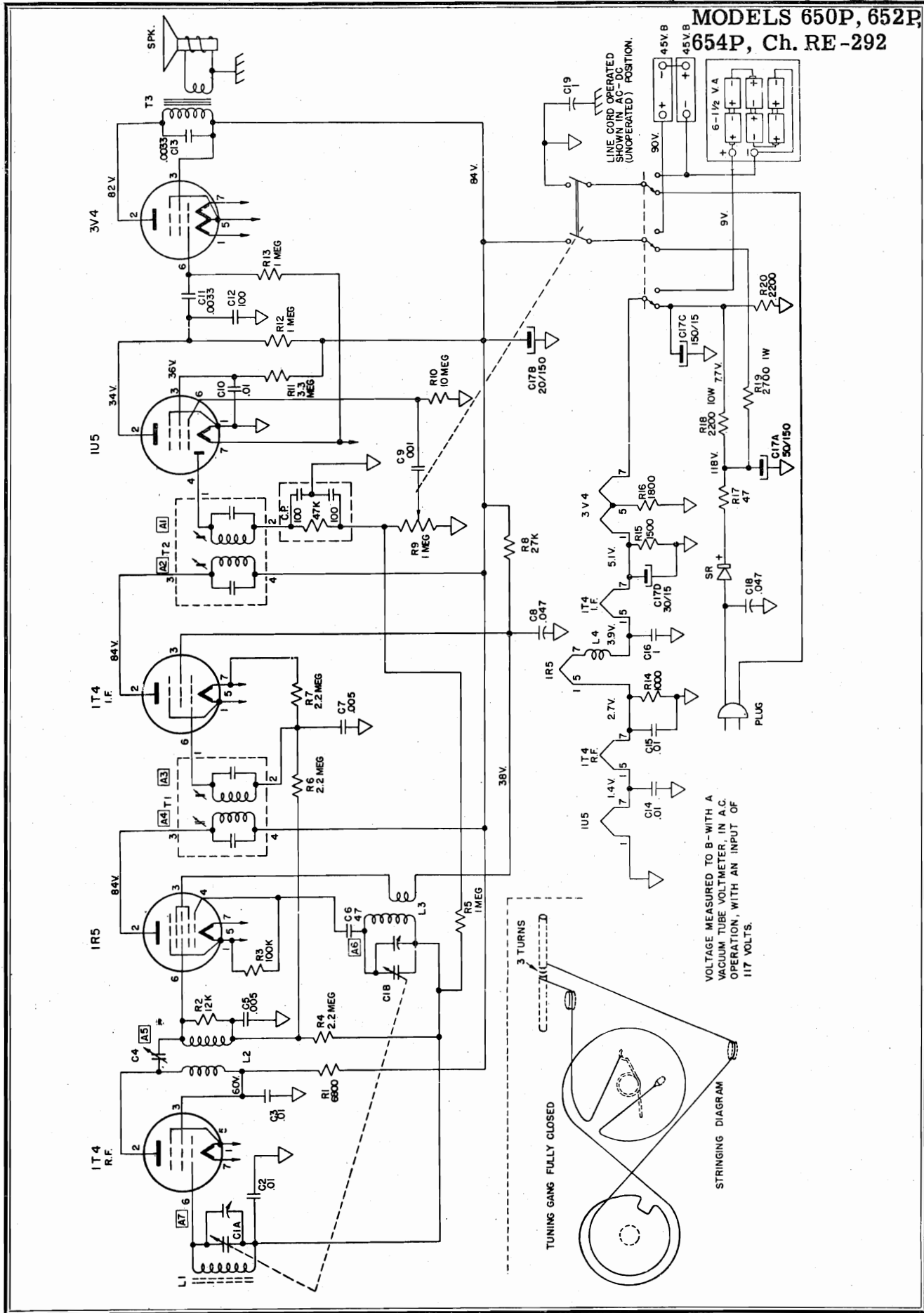

MODELS 650P, 652P, 654P, Ch. RE-292

HOW TO ORDER PARTS

Replacement parts should be ordered by Arvin part number, description and model number of receiver from your Arvin Distributor. The Distributor will order direct from the factory. All prices subject to changes in accordance with O. P. S. regulations. Parts shipments are F. O. B. Columbus, Indiana

SCHEMATIC LOCATION	PART NO.	DESCRIPTION	LIST	SCHEMATIC LOCATION	PART NO.	DESCRIPTION	LIST
L1	24372-2	Arvin Name Plate	.20		25396-3	Handle (650P-654P)	1.00
CP	25385-1	Antenna Assembly	1.40		25396-3	Handle (652P Red)	.75
	25430	Audio Coupling Unit	.30		25396-5	Handle (652P Jade)	.75
	25379-1	Battery Clip Assembly	.55		25349-1	Knob, Tuning (Tan 650P-654P)	.25
	25419	"B" Battery Cable Assembly	.45		-2	Knob, Tuning (Red 650P-652P)	.25
	25403	Cabinet, Handle Bracket Right	.10		-3	Knob, Tuning (Black 650P-654P)	.25
	25404	Cabinet, Handle Bracket Left	.10		-4	Knob, Tuning (Jade 652P-654P)	.25
	25233*	Cabinet Back (see note)*	3.50		25350-1	Knob, Volume (Tan 650P-654P)	.25
	25244*	Cabinet Front (see note)*	3.50		-2	Knob, Volume (Burgundy 650P-652P)	.25
	25315*	Cabinet Speaker Ring (see note)*	.75		-3	Knob, Volume (Black 650P-Ebony 654P)	.25
C1	25393	Capacitor, Variable	2.15		-4	Knob, Volume (Jade 652P-654P)	.25
C4	25418	Capacitor, Timmer with Bracket	.35	R17	19177	Resistor 47 10% 1w	.20
C6	21643	Capacitor 50 ufd	.20	R14	20061-102	Resistor 1000 20% 1/2w	.10
C12	20300-101	Capacitor 100 ufd Tubular Ceramic	.20	R15	20061-152	Resistor 1500 20% 1/2w	.10
C9	20424-102	Capacitor .001 ufd Ceramic	.20	X16	2381-182	Resistor 1800 10% 1/2w	.10
C11-C13	20423-332	Capacitor .0033 Ceramic	.20	R20	20061-222	Resistor 2200 20% 1/2w	.10
C5-C7	21674	Capacitor .005 Disc	.20	R18	25392	Resistor 2200 10w	.55
C2, C3, C10	22295	Capacitor .01 Disc	.25	R1	20061-682	Resistor 6800 20% 1/2w	.10
C14, C15	20068-473	Capacitor .047 Paper 400 V	.20	R19	20070-272	Resistor 2700 10% 1w	.15
C18	20067-473	Capacitor .047 Paper 200 V	.20	R2	22381-123	Resistor 12K 10% 1/2w	.10
C8	20067-104	Capacitor .1 Paper 200 V	.25	R3	22381-273	Resistor 27K 10% 1/2w	.10
C16	20068-104	Capacitor .1 Paper 400 V	.30	R8	20061-104	Resistor 100K 20% 1/2w	.10
C19	25394	Capacitor Electrolytic 5/150-20/150-150/15-30/15	2.50	R5, R12, R13, R4, R6, R7	20061-225	Resistor 2.2 meg. 20% 1/2w	.10
C17				R11	20061-335	Resistor 3.3 meg. 20% 1/2w	.10
L4	25434	Coil, RF Choke	.40	R10	20061-106	Resistor 10 meg. 20% 1/2w	.10
L2	25382-1	Coil, RF	.45		20207-5	Rectifier 75 MA Selenium	1.75
R9	25391	Coil, Oscillator	.40	SPK	25387	Speaker 4"	3.25
	25917	Control, Volume and Switch	1.00		25386	Switch, AC-Batt.	.50
	19361	Clip (rear cover)	.05	T1	21802	Spring Hinge	.05
	25348-1	Clip, hairpin (tuning shaft)	.15	T2	21797-5	Transformer IF	1.25
	25348-2	Dial Assembly (650P-654P)	1.25	T3	21797-11	Transformer IF	1.25
					25384-1	Transformer Audio Output	1.25
					25376	Tuning Shaft	.25

NOTE* Use the following suffixes with cabinet part numbers.

- 650P Sontan -1
- 650P Burgundy-2
- 650P Black -3
- 654P Jade -4
- 654P Ebony -5
- 654P Sontan-6
- 652P Red -7
- 652P Jade -8

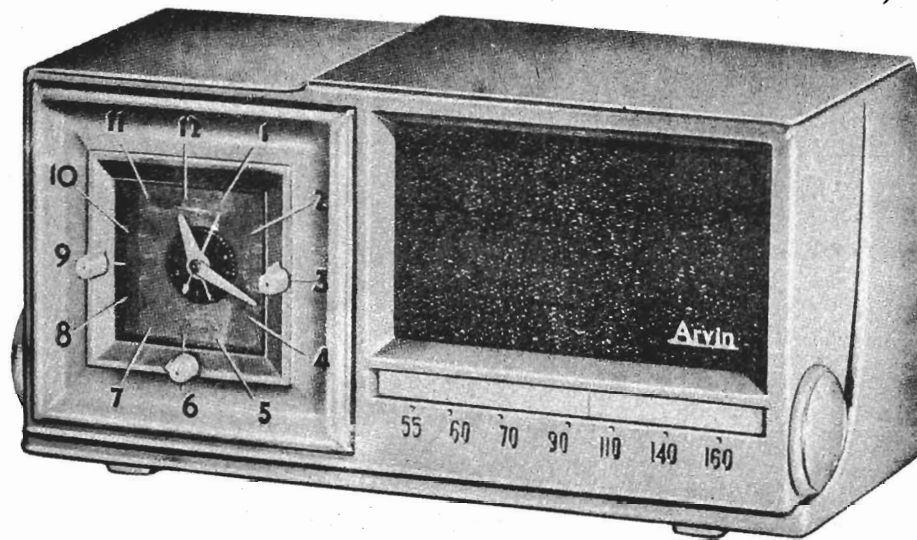

SPECIFICATIONS

FREQUENCY RANGE

Broadcast 540-1600 Kc
 IF 455 Kc

TUBES

12BE6 Converter
 12BA6 IF Amp
 12AV6 Det, Audio, Avc
 50C5 Audio Output
 35W4 Rectifier

PHYSICAL DIMENSIONS

Length 13"
 Height 6-3/4"
 Depth 6"

COLORS

Ivory Willow Green Clock Face
 Willow Green Ivory Clock Face

POWER OUTPUT

Undistorted 1.1 w.
 Maximum 2.3 w.

SPEAKER

Type Permanent Magnet
 Size 5"
 Voice Coil Impedance 3.2 ohm

RADIO CONTROLS

Left Knob Volume Control
 Right Knob Station Selector

CLOCK FACE CONTROLS

Right On-Off-Automatic
 Left Alarm
 Bottom Sleep Control
 Cabinet Rear Time Set

CHASSIS FEATURES

Clock Controlled Power
 Appliance Socket
 Alarm
 Built-In Rod Antenna
 Automatic Volume Control
 Slide Rule Dial

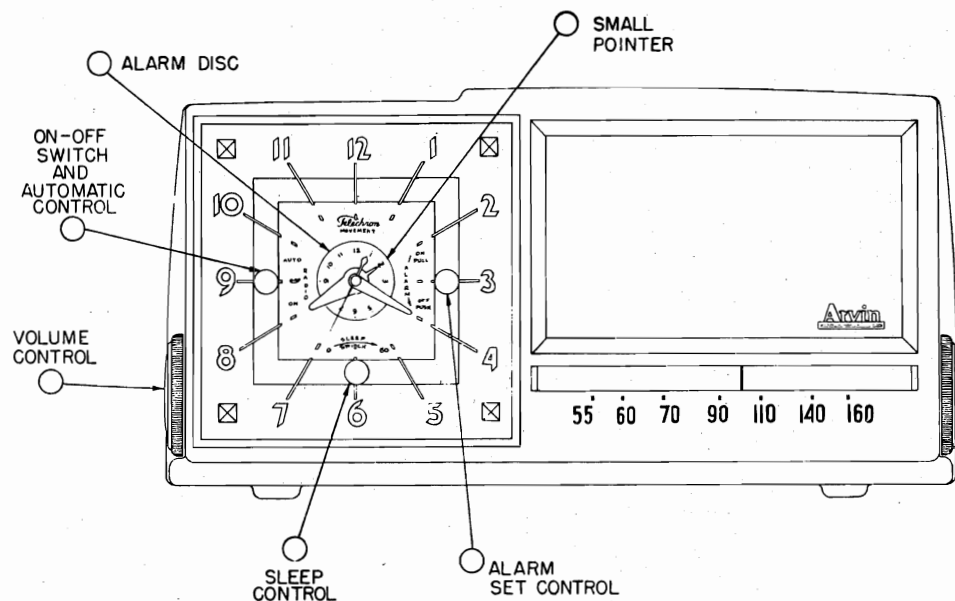

ALIGNMENT PROCEDURE

1. Connect to 117 V. AC line and turn set on with volume control at full volume.
2. Connect output meter across the speaker voice coil.
3. Connect the signal generator to the mixer grid, pin 7, using a .05 mfd condenser in series with the "hot" generator load. Connect the ground side of the generator to floating ground.
4. Set generator to 455 Kc modulated 400 cycles at 30%, tune the I.F. transformers for maximum output. Reduce the generator output as the signal increases so that final adjustment is made with lowest input possible to give a good signal to noise ratio at the output.
5. Connect generator to a radiating loop, set to 1400 Kc. Close the variable condenser and set the pointer to 540 Kc. This is indicated by a notch in the top of the dial plate. First notch to the left is 540, second 600 Kc, 1000 Kc, and 1400 Kc. After setting the pointer tune to 1400 Kc trim the oscillator and antenna stages for maximum output. Repeat trimmer adjustments until no further increase is obtained.
6. Set generator at 600 Kc. Tune receiver to 600 Kc. Adjust antenna section condenser plates for maximum output.
7. Check calibration and coverage after alignment coverage must be 535 Kc to 1650 Kc.

ELECTRICAL TEST FOR CLOCK

- A. By turning right hand knob set alarm disc to an even hour number.
- B. Turn left hand clock knob to the "AUTO" position:
- C. Turn rear knob or time set knob until radio goes on.
- D. There should not be more than seven minutes difference between alarm disc and time shown by the hands on clock face.
- E. Check sleep switch by setting to the 60 minute position. Rotate time set knob until radio shuts off. Time shown by the hands on the clock face should be one hour plus or minus seven minutes.
- F. Clock switch must have a definite snap action on the ON-OFF-AUTO switch.

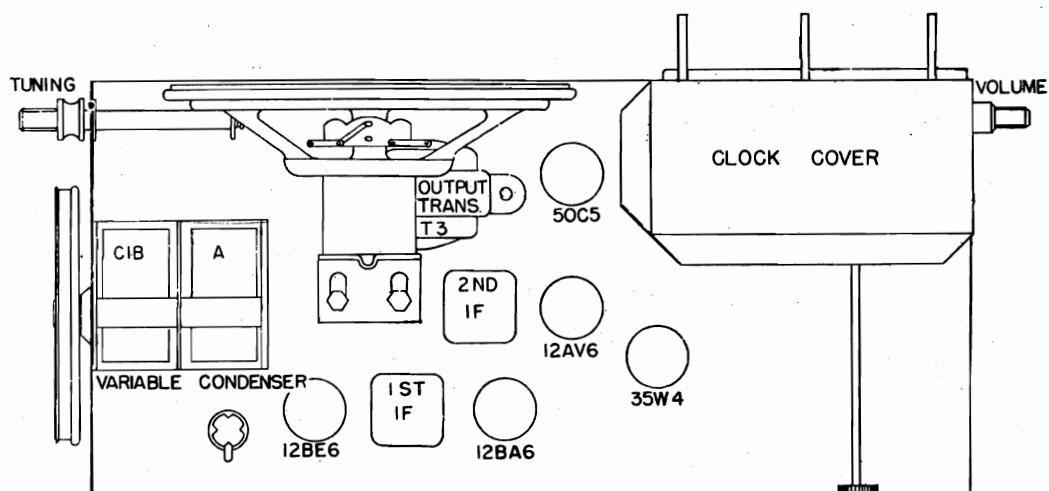

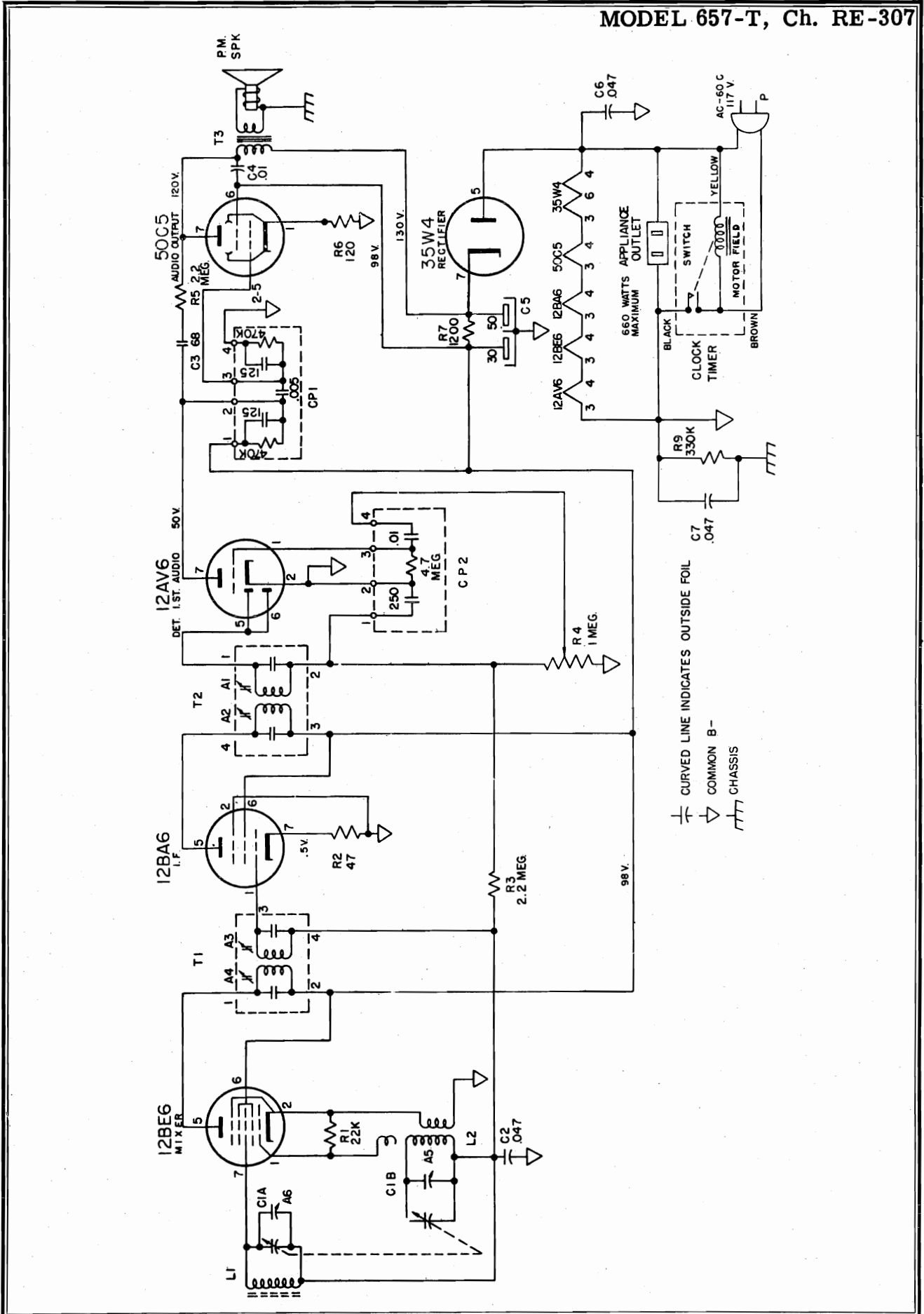

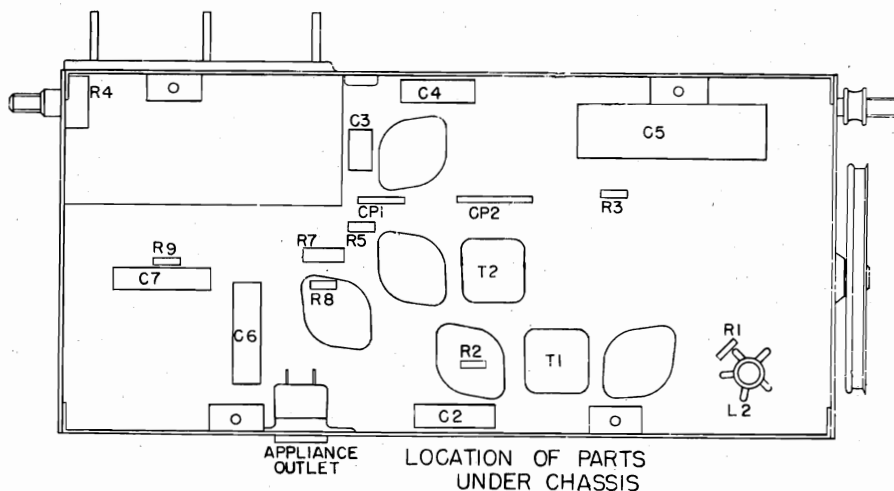

HOW TO ORDER PARTS

Replacement parts should be ordered by Arvin part number, description and model number of receiver from your Arvin Distributor. The Distributor will order direct from the factory, except in the case of tubes, which should be obtained through regular tube distribution channels.

Part No.	Description	Part No.	Description
AD25191-1	Antenna Rod and Rear Cover	A25233-1	Knob, Clock
R25169-1	Cabinet, Willow Green	A25170-1	Knob, Radio
R25169-2	Cabinet, Ivory	C20138	Line Cord
C20065-680	Capacitor, 68uuf 500V Mica, C3	IF25259	Pointer (Radio)
C20292-103	Capacitor, .01 400V, C4	C20061-470	Resistor 47 ohm 1/2w 20%, R2
C20292-473	Capacitor, .047 400V, C7 C6	C22381-121	Resistor 120 ohm 1/2w 10%, R6
C20291-473	Capacitor, .047 200V, C2	C20061-334	Resistor 330 ohm 1/2w 20%, R9
A25196	Capacitor, Electrolytic 50-30/150, C5	C20070-122	Resistor 1200 ohm 1w 10%, R7
C25195	Capacitor, Variable, C1	C20061-223	Resistor 22K ohm 1/2w 20%, R1
D25171	Clock Crystal	C20061-225	Resistor 2.2 meg 1/2w 20%, R3 R5
C25229	Clock Face Mat	A19551	Socket, Power
D25189-1	Clock Timer	C25194	Speaker 5" PM
AC25192-1	Coil, Oscillator, L2	A25186	Speaker Mtg. Bracket
A20222-1D	Clip, Push on (Mtg. Clock Crystal)	AC25174-1	Speaker Baffle Assy.
A19361	Clip, Hairpin (Tuning Shaft)	A25263	Shielded Lead
A21792	Clip, Spring (IF Mtg.)	A19133	Spring (Dial Cord Tension)
C25197	Control, Volume, R4	A19124	Snap Buttons, Speaker Baffle Mtg.
A25257	Couplate, CP2	A25633	Tuning Shaft
A25264	Couplate, CP1	C21797-6	Transformer, IF, T1, T2
C25185-2	Dial Plate (All Willow Green)	A25263	Transformer, Audio Output, T3
A22941	Flapper Stud, Read Cover Mtg.		

CLOCK REPAIR AND PARTS

For the address of the Telecron service station nearest you, contact your Arvin Distributor or write to the Arvin Factory.

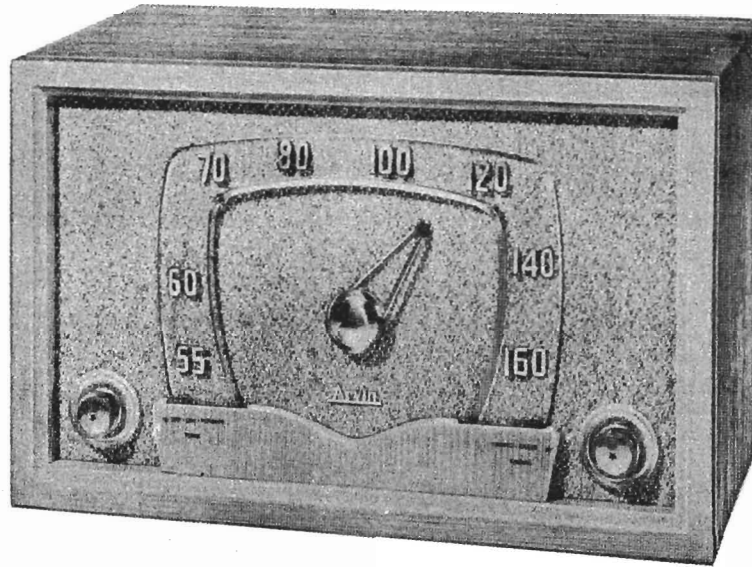

ELECTRICAL AND MECHANICAL SPECIFICATIONS

FREQUENCY RANGE

Broadcast 540-1600 kc
 IF 455 kc

TUBES AND FUNCTIONS

6BE6 Mixer-oscillator
 6BA6 I.F. AMP
 6AV6 Detector — AVC-AF.
 6V6 Output
 5Y3' Rectifier

POWER OUTPUT

Type: Beam tube
 Undistorted 3.5 Watts
 Maximum 4.5 Watts

LOUD SPEAKER

Type: Permanent magnet, 2.15 oz., Alnico 5
 Size: 9 x 6 inch
 Voice coil impedance 3.2 Ohms

CHASSIS FEATURES

Automatic Volume Control
 Built-in-Loop
 Underwriter's Listed

OPERATING CONTROLS

1. Right knob.....Tuning and Phono-Radio
2. Left knob.....ON-OFF, Volume and Tone

PHYSICAL DIMENSIONS

Length 15 inches
 Width 7 7/8 inches
 Height 9 inches

ALIGNMENT PROCEDURE

PRELIMINARY:

Output meter connection.....Across loudspeaker voice coil
 Output meter reading to indicate .5W (standard output).....1.26 volts
 Connection of generator ground lead.....Chassis
 Generator Modulation.....30% 400 cycles
 Position of volume & tone control.....Fully clockwise
 Position of dial pointer with variable fully closed.....To left

1. Connect signal generator lead through a .05 uf condenser to converter grid. Open tuning condenser. Set signal generator to 455 Kc. Tune I.F. Trimmers A1, A2, A3 and A4 for maximum output.
2. Close tuning condenser and set pointer to left. Open tuning condenser. Connect signal generator to test loop or to blue lead on set loop. Set signal generator to 1650 Kc. Tune A5 trimmer on oscillator section of tuning condenser for maximum output.
3. Set signal generator to 1400 Kc. Adjust tuning shaft until maximum output is obtained. Tune antenna trimmer A6 on tuning condenser for greatest output. Reset tuning shaft until output is again maximum. Retune antenna trimmer. Repeat this cycle of operations at 1400 Kc. until no further increase of output can be obtained. Keep generator output at a low value to prevent detuning by A.V.C. action.
4. Set signal generator to 600 Kc. Adjust tuning shaft for maximum output. Adjust tuning condenser plate for maximum output if necessary.

Approximate sensitivities with 117 V. AC line voltage and .5 W. output across voice coil should be: Antenna lead 600 Kc, —600 uv/m., 1000 Kc.—400 uv/m., 1400 Kc.—300 uv/m.

MODELS 751TB,
751TM, Ch. RE-
343

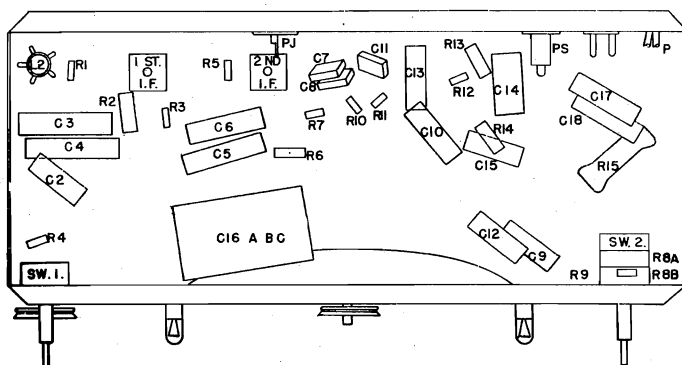

LOCATION OF PARTS UNDER CHASSIS

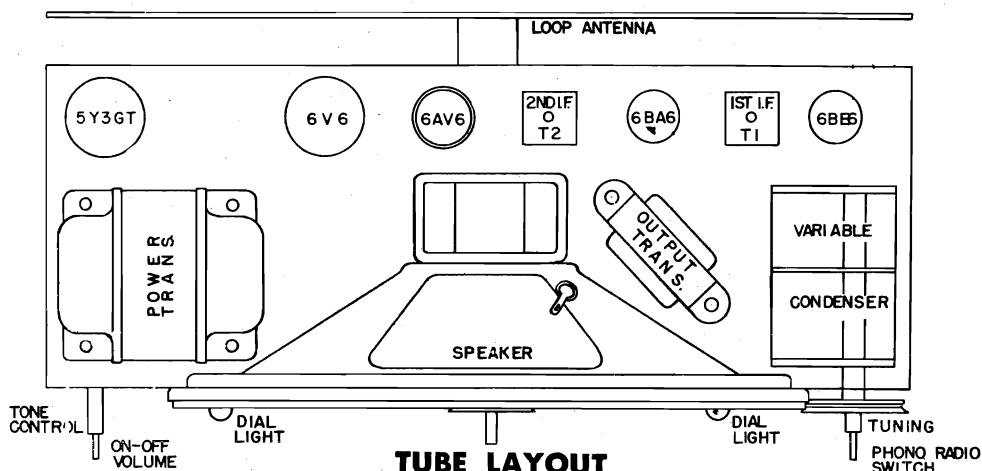

TUBE LAYOUT

HOW TO ORDER PARTS

parts should be ordered by Arvin part number, description and model number of receiver from your Arvin Distributor. The Distributor will order direct from the factory. All prices subject to changes in accordance with O.P.S. regulations. Parts shipments are F.O.B. Columbus, Indiana.

Schematic Location	Part Number	Description	List
L1	D24777	Antenna Loop Assembly	1.50
C1A, B	C24305	Capacitor, Variable, 2 Gang with Trimmers	2.10
C2	C20067-503	Capacitor, .05 mfd. 200 V P.T.	.20
C3, C4, C5, C6	C20069-503	Capacitor, .05 mfd 600 V P.T.	.20
C7, C8	C20065-101	Capacitor, 100 mmfd, 500 V, Mica	.30
C9	C20067-502	Capacitor, .005 mfd, 200 V, P.T.	.20
C10	C20068-502	Capacitor, .005 mfd, 400 V, P.T.	.10
C11	C20065-251	Capacitor, 250 mmfd, 500 V, Mica	.20
C12, C13	C20068-103	Capacitor, .01 mfd, 400 V, P.T.	.20
C14	A22602	Capacitor, 10 mfd, 25 V, Electrolytic	.65
C15	C20069-502	Capacitor, .005 mfd, 600 V, P.T.	.10
C16A, B, C	C24415	Capacitor, 20-20-20 mfd, 450 V, Electrolytic	1.75
C17, C18	D20358-103	Capacitor, .01 mfd, 600 V, Molded	.50
L2	AC24482-1	Coil, Oscillator Assembly	.50
R8A, B	C40389	Control, Volume and Tone, Dual 500K-500K ohms	1.80
	A19132	Cord, Dial Drive	10 for .25
	D40404	Cover, Cabinet Rear, Blonde	.35
	D40404-1	Cover, Cabinet Rear, Mahogany	.35
	C24449	Dial, Pointer	.30
	E24447	Dial, Crystal	2.75
	AD40399-1	Grille, Assembly, Blonde	1.00
	AD40399-2	Grille, Assembly, Mahogany	1.00
	A24442-2	Knob, Volume, Radio-Phono	.30

Schematic Location	Part Number	Description	List
	A24443-2	Knob, Tone, Tuning	.20
	A19351	Lamp, Dial Mazda No. 47	.20
	B20138-15	Line Cord	.75
	A19552	Phono Jack	.10
	AC24475-1	Pointer, Shaft & Bracket Ass'y.	.35
R1	C20061-223	Resistor, 22K ohm, 20% 1/2w	.10
R2	C20302-223	Resistor, 22K ohm, 10% 2w	.10
R3	C20061-332	Resistor, 3.3K ohm, 20% 1/2w	.10
R4	C20061-225	Resistor, 2.2 megohm, 20% 1/2w	.10
R5	C20061-680	Resistor, 68 ohm, 20% 1/2w	.10
R6	C20070-473	Resistor, 47K ohm, 10% 1w	.10
R7, R9	C20061-473	Resistor, 47K ohm, 20% 1/2w	.10
R10	C20061-685	Resistor, 6.8 megohm, 20% 1/2w	.10
R11, R12	C20061-474	Resistor, 470K ohm, 20% 1/2w	.10
R13	C20070-271	Resistor, 270 ohm 10% 1w	.15
	or		
	A24891	Resistor, 270 ohm 10% 1w Wire	.15
R14	C20070-821	Resistor, 820 ohm, 10% 1w	.15
R15	C23970-14	Resistor, 750 ohm 10% 5w Wire	.40
R16	A24761	Resistor, 2 ohm 10% 1/2w Wire	.10
	A24435-1	Socket, Dial Lamp, Left	.15
	A24435-2	Socket, Dial Lamp, Right	.15
	A19551	Socket, AC Phono Motor	.25
SPK	D24402	Speaker, 6" x 9" P.M.	6.10
	A24653	Spring, Dial Drive Cord	.15
SW-1	C40388	Switch, Phono-Radio	1.60
T1	C21797-16	Transformer, 1st I.F.	1.20
T2	C21797	Transformer, 2nd I.F.	1.25
T3	C24776-2	Transformer, Output	1.35
T4	D24440	Transformer, Power	3.75

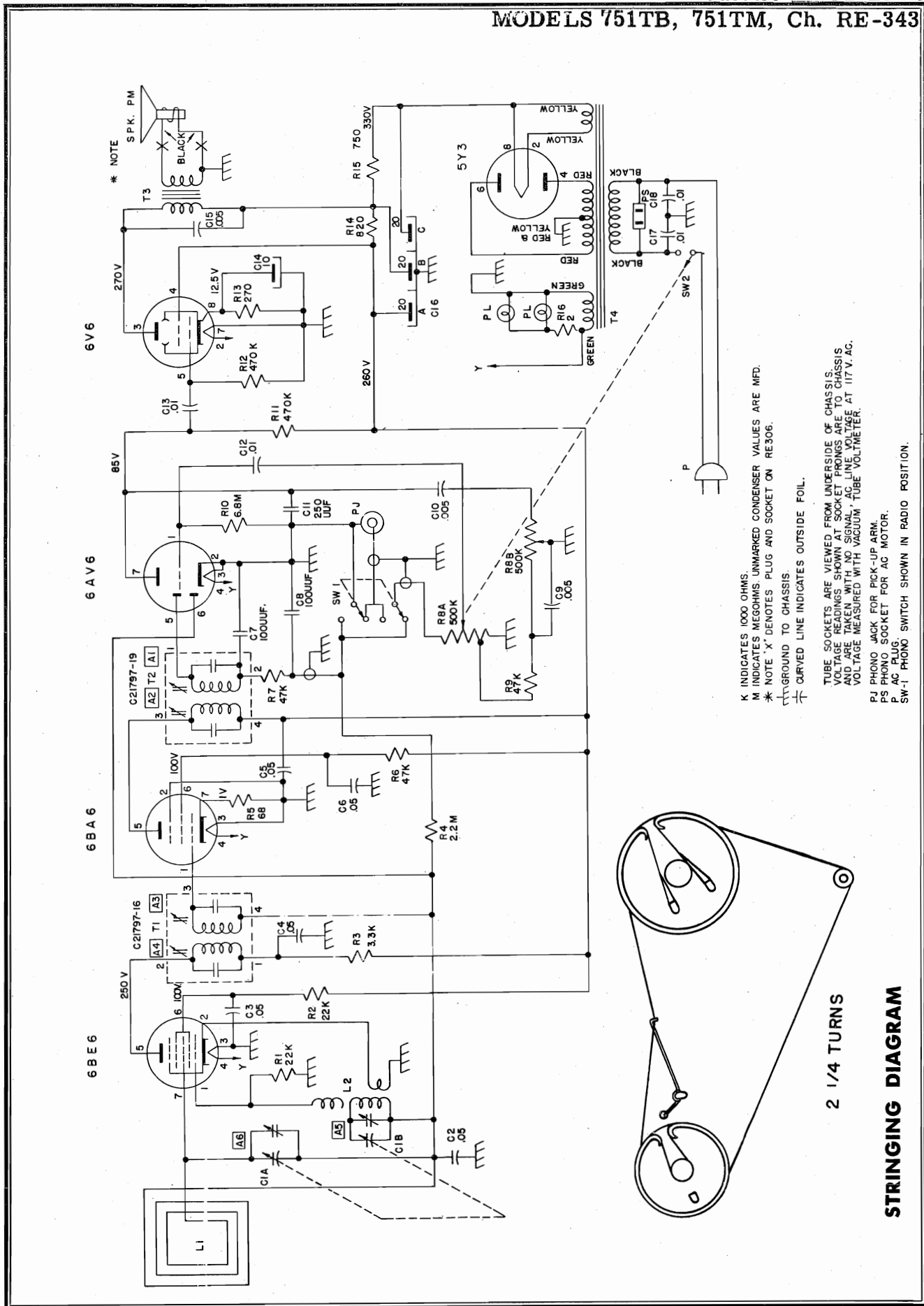

K INDICATES 1000 OHMS.
M INDICATES MEGOHMS UNMARKED CONDENSER VALUES ARE MFD.
* NOTE 'X' DENOTES PLUG AND SOCKET ON RE306.
⊥ GROUND TO CHASSIS.
⤵ CURVED LINE INDICATES OUTSIDE FOIL.

TUBE SOCKETS ARE VIEWED FROM UNDERSIDE OF CHASSIS.
VOLTAGE READINGS SHOWN AT SOCKET PRONGS ARE TO CHASSIS
AND ARE TAKEN WITH NO SIGNAL, AC LINE VOLTAGE AT 117 V. AC.
VOLTAGE MEASURED WITH VACUUM TUBE VOLTMETER.

PJ PHONO JACK FOR PICK-UP ARM.
PS PHONO SOCKET FOR AC MOTOR.
P. AC PLUG.
SW-1 PHONO SWITCH SHOWN IN RADIO POSITION.

MODEL 655SWT, Ch. RE-327



SPECIFICATIONS

FREQUENCY
 Broadcast (AM) 540-1600 KC
 Shortwave (SW) 6.0-18.0 MC

POWER OUTPUT
 Undistorted 1.0 Watts
 Maximum 1.5 Watts

Speaker Voice Impedance 3.2 ohms

TUBES AND FUNCTION

12BE6 Converter
 12BA6 I.F. Amplifier
 12AV6 Det. 1st Audio
 50C5 Output
 35W4 Rectifier

OPERATING CONTROLS

1. Left Knob On-Off Switch & Volume
 2. Center Knob Shortwave-Broadcast
 3. Right Knob Tuning

PHYSICAL DIMENSIONS

Length 13⁷/₈ inches
 Height 6⁷/₈ inches
 Depth 7⁷/₈ inches

TECHNICAL INFORMATION FOR SERVICE MEN

AM Tuning range—540 Kc to 1600 Kc. Intermediate Frequency—455 Kc. I.F. and R.F. measurements made at 500 milliwatts output—approximately 1.27 volts on a rectifier type voltmeter connected across speaker voice coil. Approximately input for 500 MW output: R.F. with standard loop: at 600 Kc, 480 uv/m, at 1000 Kc, 360 uv/m; at 1400 Kc, 240 uv/m.

PRELIMINARY:

Output meter connection..... Across speaker voice coil
 Output meter reading to indicate 500 MW..... 1.27 volts
 Generator Modulation..... 30%, 400 cycles
 Position of volume control..... Fully clockwise
 Set band switch..... To left for AM alignment, to right for SW alignment

AM Alignment

Position of Variable	Generator Frequency	Dummy Ant.	(high) Generator Connection	Generator Connection Ground Lead	Adjust Trimmer In Order Shown For Max. Output	Trimmer Function
Open	455 Kc	.05 mfd.	Mixer Grid	Floating Grnd.	A1, A2, A3, A4,	I.F.
Open	1670 Kc		Test Loop	Test Loop	A6	Oscillator
Closed	535 Kc		Test Loop	Test Loop	A5	Osc. Pad.
1400 Kc	1400 Kc		Test Loop	Test Loop	A7	Antenna
600 Kc	600 Kc		Test Loop	Test Loop	A5	Osc. Pad.

Connect generator lead to a Standard Hazeltine Test Loop, Model 1150, place two feet from the set loop, or three turns of wire about six inches in diameter, placed about one foot from the set loop.
 The alignment procedure should be repeated in the original order for greatest accuracy. Always keep the output from the signal generator at its lowest possible value to make the A.V.C. action of the receiver ineffective.

SHORT WAVE R.F. ALIGNMENT

- A. Before attempting short wave alignment, the Broadcast IF Alignment procedure must be completed.
- B. Connect the Signal Generator to the antenna terminals (bank disconnected). A 50 MMF "Dummy" must be used in the "high-side" of the generator-lead and the generator "groundlead" connects directly to the ground-terminal.
2. In aligning the short wave band some trouble may be experienced with image frequencies. The image frequency is separated from the desired frequency by a 910 Kc difference. In order to identify which signal is being picked up, use the following procedure to assure the receiver oscillator is above the incoming signal:
- With variable condenser completely open and the trimmer, A8, loose set the signal generator to 18 Mc. Then gradually tighten the trimmer until a signal is heard. This is the correct frequency. Now if the variable condenser is closed slightly, another signal will be picked up. This is the image frequency and must not be confused with the above desired frequency. This relationship must be maintained throughout the following balancing procedure. The image frequency must always be found by closing the variable a slight amount.
 - Set generator to 6 Mc. The set must tune to maximum output slightly before variable is completely closed.
 - Set generator to 16 Mc. Rotate variable until the 16 Mc signal is heard at two points near the open position of the variable. Again the desired signal is the one with the variable open the farthest. Adjust the trimmer, A9, as for maximum output. Rotate variable very slightly for a new maximum and repeat trimmer A9. Repeat this operation until no further increase can be obtained.

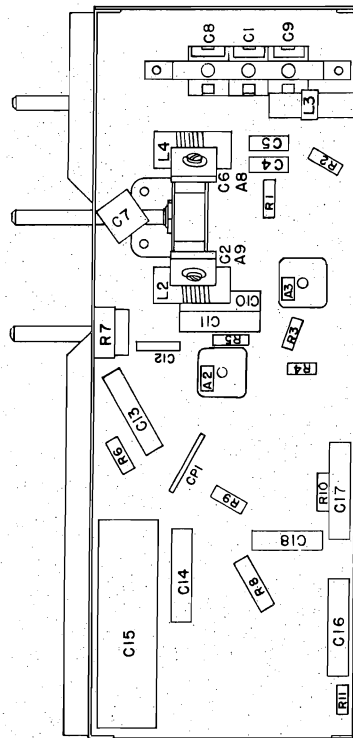

LOCATION OF PARTS UNDER CHASSIS

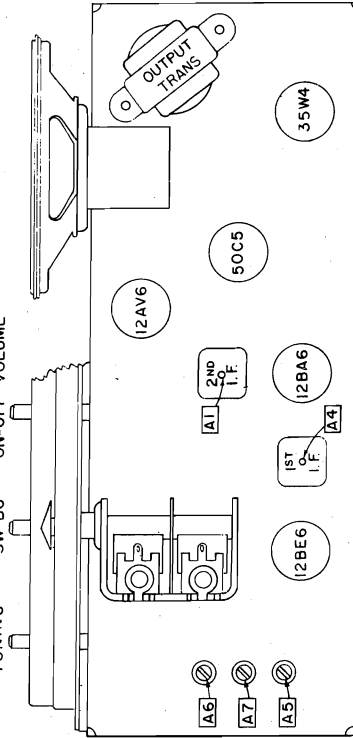

TUBE LAYOUT

HOW TO ORDER PARTS

parts should be ordered by Arvin part number, description and model number of receiver from your Arvin Distributor. The Distributor will order direct from the factory.

Prices are subject to change without notice.

Part Number	Schematic Location	Description	List
C20067-473	C10, 11	Capacitor, .047 mfd., 200V	.20
C20068-103	C14	Capacitor, .01 mfd., 400V	.30
C20068-473	C16, 17, 18	Capacitor, .047 mfd., 400V	.30
C20067-103	C13	Capacitor, .01 mfd., 200V	.20
C20065-470	C5	Capacitor, 47 mmf	.20
C20065-101	C4	Capacitor, 100 mmf	.20
C20065-221	C12	Capacitor, 200 mmf	.20
C23099-562	C7	Capacitor, 5600 mmf	.25
A25830	C15	Capacitor, electrolytic	
C25834	C3A, B	Capacitor, variable	
C25832	C1, 8, 9	Capacitor, Trimmer	
C20061-151	R9	Resistor, 150 ohm	.10
C20061-101	R4	Resistor, 100 ohm	.10
C20061-102	R3	Resistor, 1000 ohm	.10
C20223-122	R8	Resistor, 1200 ohm 2w 10%	.20
C20061-223	R2	Resistor, 22K ohm	.10
C20061-334	R10	Resistor, 330K ohm	.10
C20061-105	R1	Resistor, 1 megohm	2.00
C20061-225	R5	Resistor, 2.2 megohm	2.25
C20061-475	R6	Resistor, 4.7 megohm	.80
R23228-5	R2	Resistor, 150 ohm	.10
C23299	R4	Resistor, 100 ohm	.10
A24464-5	R5	Resistor, 1000 ohm	.10
Miscellaneous			
AC25843-1	L2	Antenna coil S.W.	.10
Cabinet			
R23228-5		Resistor, 150 ohm	.10
C23299		Resistor, 100 ohm	.10
A24464-5		Resistor, 1000 ohm	.10
Miscellaneous			
AC25843-1		Antenna coil S.W.	.10
Cabinet			
Sea-Mist		Cabinet, Sea-Mist	4.25
Sea-Mist		Cabinet, rear cover	.25
Sea-Mist		Knob, Sea-Mist	.25
Sea-Mist		Antenna coil S.W.	.60

MODEL 655SWT, Ch. RE-327

- | | | | |
|--------------------|---------------------------|---------------------------|-------------|
| Part Number | Schematic Location | Description | List |
| D25844 | L1 | Antenna loop | 1.25 |
| B22953 | | Antenna loop mtg. brkt. | .10 |
| A25838 | | Antenna terminal board | .20 |
| A23237 | | Carton | .90 |
| C22963 | R7 | Control, volume & switch | .80 |
| A25873 | CP1 | Couplate | .60 |
| A19132 | | Dial Cord (10 for) | .25 |
| 19133 | | Dial Cord Spring (10 for) | .25 |
| E40080 | | Dial crystal | 2.00 |
| A19351 | | Dial light bulb | .20 |
| A19628-2 | | Dial light socket | .25 |
| AC23302-5 | | Dial Plate Assembly | .35 |
| A19361 | | Hairpin clip (10 for) | .15 |
| A40474 | | I.F. Mtg. clip (5 for) | .10 |

- | | | | |
|-----------|--------|-------------------------|------|
| C20138-15 | | Line cord & plug | .60 |
| AC25871-1 | L3 | Oscillator coil B.C. | .60 |
| AC25843-1 | L4 | Oscillator coil S.W. | .25 |
| C23461-1 | | Pointer | .10 |
| A19124 | | Snap fasteners (10 for) | .30 |
| A20243-3 | | Socket, tube plain | .25 |
| A20243-1 | | Socket, tube plain | 3.40 |
| C25756 | | Speaker | .10 |
| A22941 | | Stud, flapper (10 for) | 1.15 |
| C25831 | | Switch, band | .10 |
| C25859 | | Switch band mtg. brkt. | 2.35 |
| C21797-6 | T1, T2 | Transformer I.F. | 1.25 |
| AC25868-1 | T3 | Transformer, output | .90 |
| A25832 | | Trimmer assembly | .15 |
| A22957-1 | | Tuning shaft | .10 |
| A25156 | | Tuning shaft brkt. | |

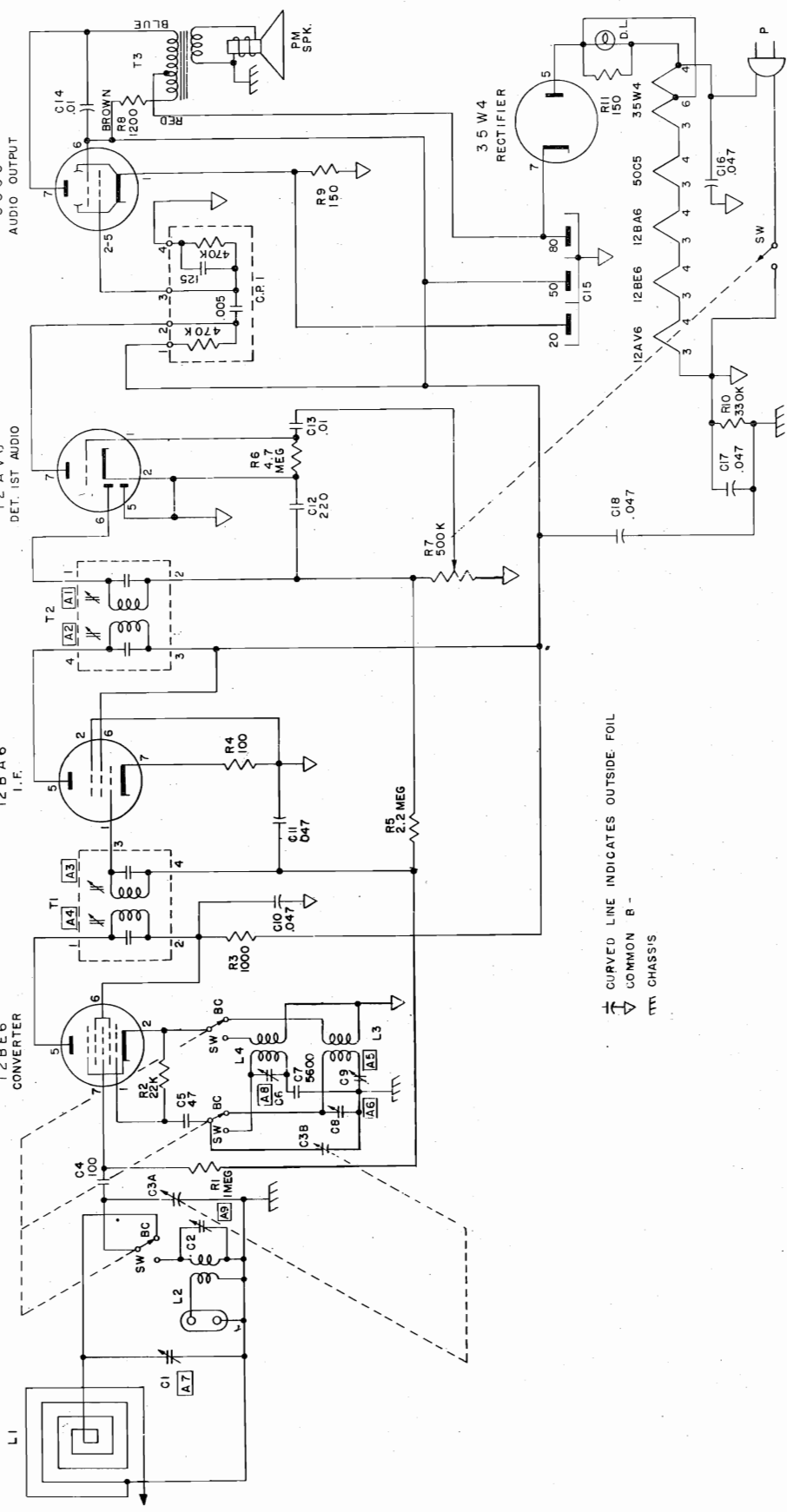

CURVED LINE INDICATES OUTSIDE FOIL
 COMMON B -
 CHASSIS

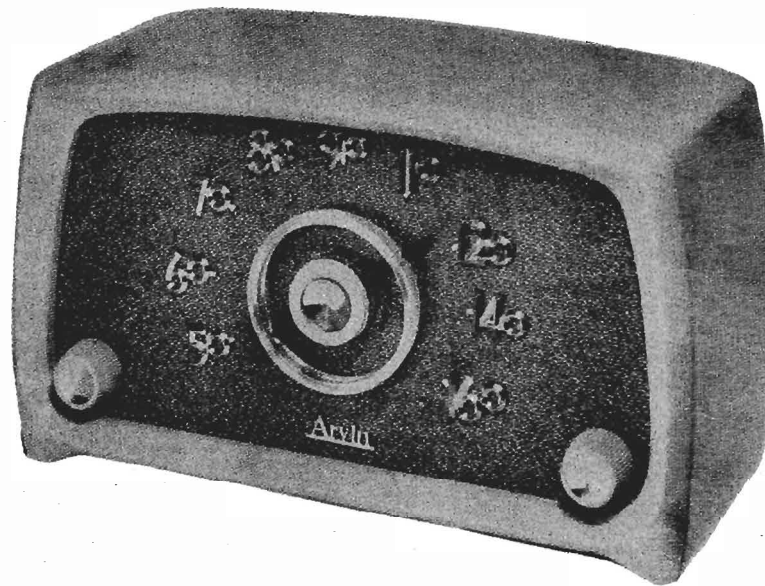

SPECIFICATIONS

FREQUENCY RANGE

Broadcast 540-1600 kc
IF 455 kc

TUBES AND FUNCTIONS

12BE6 Mixer-oscillator
12BA6 IF Amp.
12AT6 DET-AVC AF Amp.
50C5 Output
35W4 Rectifier

POWER SUPPLY

105-125 Volts, AC-DC, 35 Watts

POWER OUTPUT

Undistorted 1 Watt
Maximum 1.5 Watts

LOUD SPEAKER

Type: Permanent magnet
Size: 5 Inch
Voice coil impedance 3.2 Ohms

CHASSIS FEATURES

Automatic Volume Control
Built-in Loop
Underwriters' Listed

OPERATING CONTROLS

1. Left knob ON-OFF Sw and Volume
2. Right knob Tuning

PHYSICAL DIMENSIONS

Length 11 $\frac{3}{4}$ inches
Height 7 inches
Depth 6 inches

THE ANTENNA

This receiver has a built-in loop which gives satisfactory reception in most locations. If the receiver is located some distance from a broadcasting station or where the electrical interference is high, an outside antenna connected to the pickup lead on the loop will improve reception.

This receiver is designed to operate without a ground connection and no attempt should be made to use one.

ALIGNMENT PROCEDURE

PRELIMINARY:

Output meter connection Across speaker voice coil
Output meter reading to indicate 500 milliwatts (standard output) 1.27 volts
Dummy antenna value to be used in series with generator output See chart below
Connection of generator output lead See chart below
Connection of generator ground lead Floating ground
Generator modulation 30% 400 cycles
Position of volume control Fully clockwise
Position of dial pointer with variable fully closed Last mark at left end of dial

ALIGNMENT PROCEDURE

PRELIMINARY:

Output meter connection.....	Across speaker voice coil
Output meter reading to indicate 500 milliwatts (standard output).....	1.27 volts
Dummy antenna value to be used in series with generator output.....	See chart below
Connection of generator output lead.....	See chart below
Connection of generator ground lead.....	Floating ground
Generator modulation.....	30% 400 cycles
Position of volume control.....	Fully clockwise
Position of dial pointer with variable fully closed.....	Last mark at left end of dial

Position of Variable	Frequency of Generator	Dummy Antenna	Generator Output Connection	Trimmers Adjusted in Order Shown for Maximum Output	Function of Trimmer
Open	455	.05 mfd.	12BE6 Grid (Stator of C1A)	A1, A2, A3, A4	IF
1400	1400		*Test Loop	A5, A6 on Variable Condenser Check Point	Osc. Ant.
600	600		*Test Loop		

*Standard Hazeltine Test Loop Model 1150 or 3 turns of wire about 6" in diameter placed about one foot from the set loop.

The alignment procedure should be repeated in the original order for greatest accuracy. Always keep the output from the signal generator at its lowest possible value to make the AVC action of the receiver ineffective.

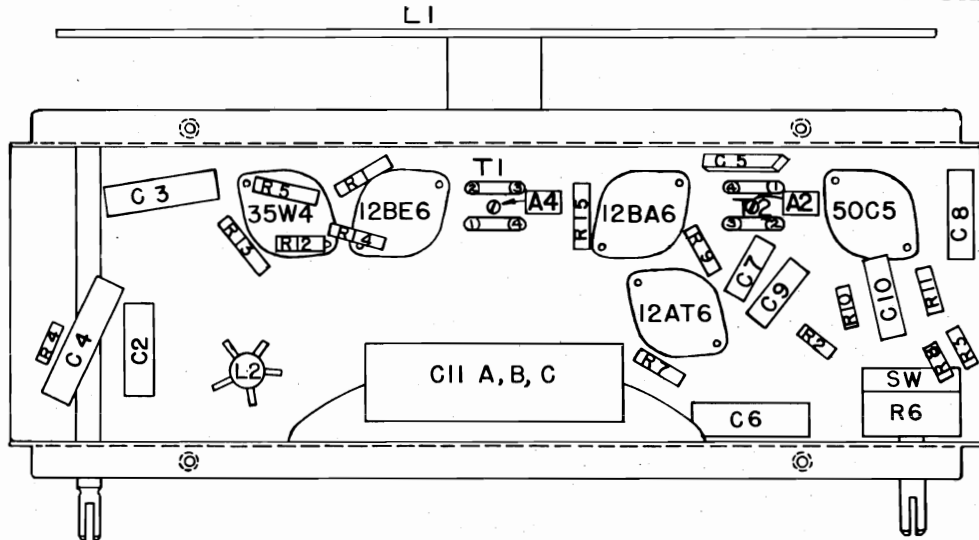
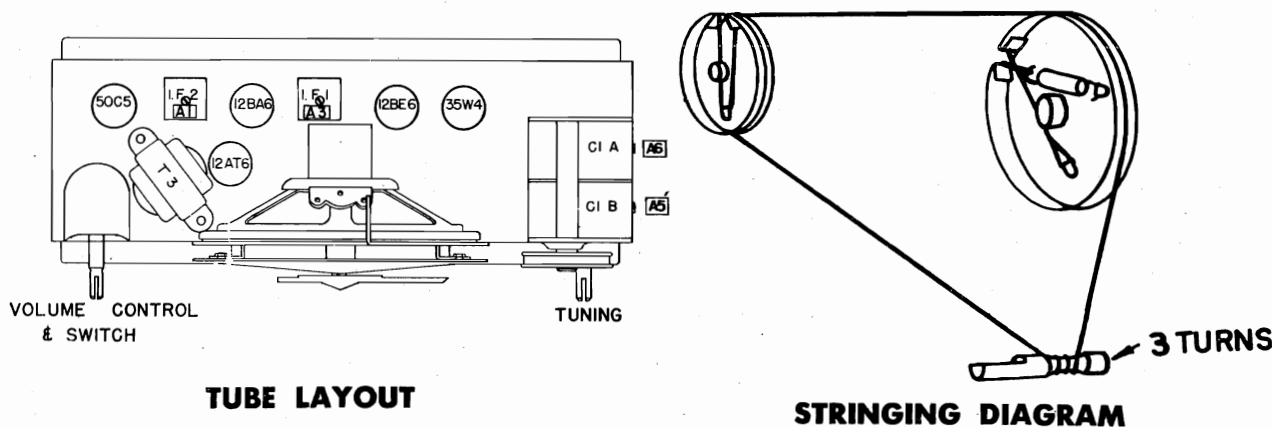

LOCATION OF PARTS UNDER CHASSIS

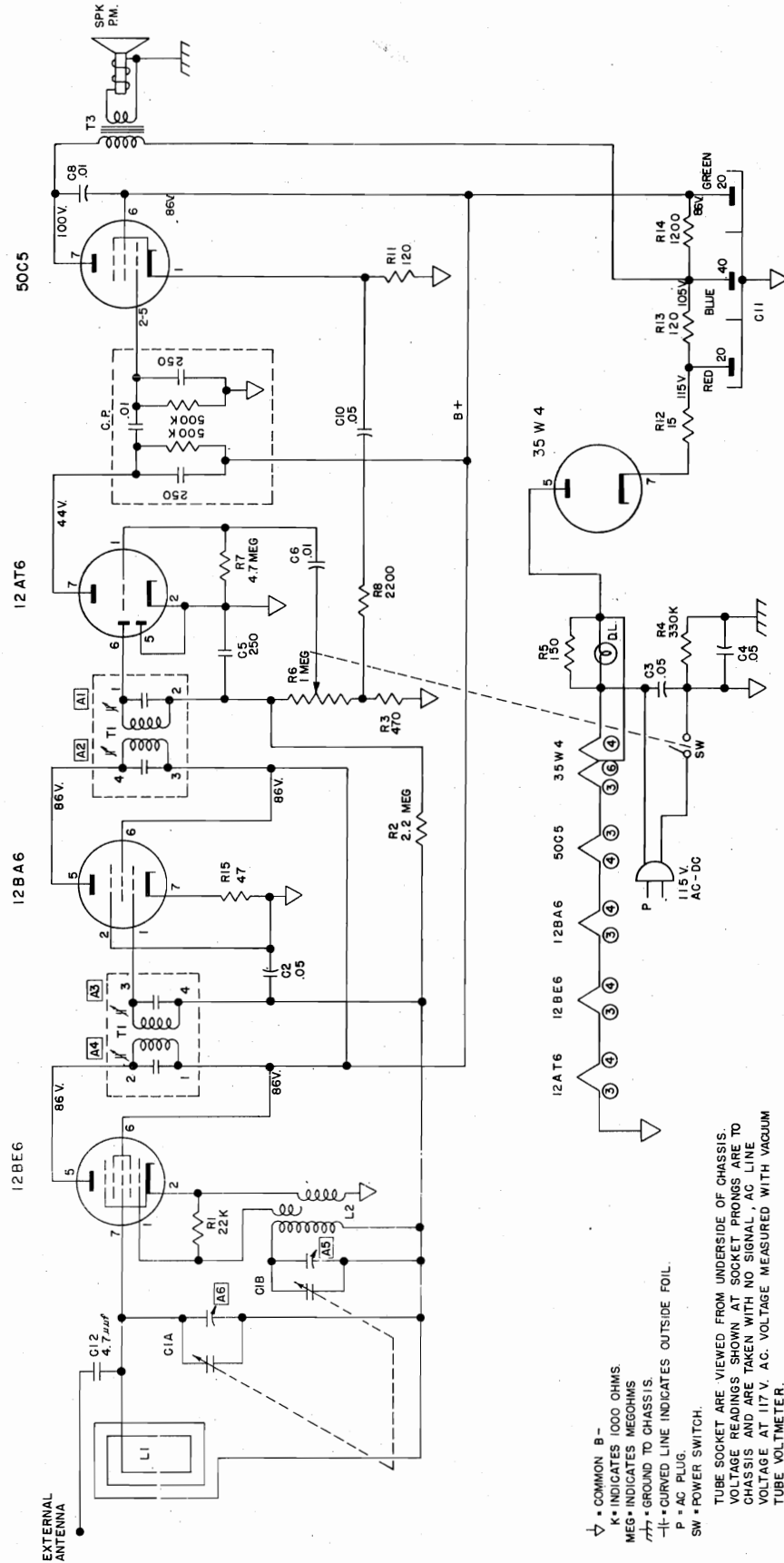

▽ • COMMON B-
 K • INDICATES 1000 OHMS.
 MEG • INDICATES MEGOHMS
 --- • GROUND TO CHASSIS.
 -|- • CURVED LINE INDICATES OUTSIDE FOIL.
 P = AC PLUG.
 SW = POWER SWITCH.
 TUBE SOCKET ARE VIEWED FROM UNDERSIDE OF CHASSIS.
 VOLTAGE READINGS SHOWN AT SOCKET PRONGS ARE TO CHASSIS AND ARE TAKEN WITH NO SIGNAL, AC LINE VOLTAGE AT 117 V. AC. VOLTAGE MEASURED WITH VACUUM TUBE VOLTMETER.

HOW TO ORDER PARTS

parts should be ordered by Arvin part number, description and model number of receiver from your Arvin Distributor. The Distributor will order from the factory.

Parts shipments are F.O.B. Columbus, Indiana. Prices are subject to change without notice.

REPLACEMENT PARTS LIST FOR 651T

Part Number	Schematic Location	Description	List	Part Number	Schematic Location	Description	List
Capacitors							
C25569	C1, A, B	Capacitor, variable	2.25	AD25559-1		Baffle ass'y. with cloth & numerals	3.10
C23470	C11	Capacitor, Elect. 20-40-20 150V	1.45			Ebony (Ch-gold cloth)	
C20065-251	C5	Capacitor, Mica 250 mmf. 500V	.15	AD25559-3		Baffle ass'y. with cloth & numerals	3.10
C20067-503	C2, C10	Capacitor, paper tubular, .05 mf. 200 V	.20			California Tan (Mahogany—gold cloth)	
C20068-503	C3, C4	Capacitor, paper tubular, .05 mf. 400V	.20	A25558-1		Knobs, ivory	.30
C20068-103	C6, C8	Capacitor, paper tubular, .01 mf. 400V	.20	A25558-2		Knobs, willow green	.30
A20238-6	C12	Capacitor, 4.7 mmf.	.10	A25558-3		Knobs, California Tan	.30
A24084	C.P.	Couplate	.50	A25558-4		Knobs, Ebony	.50
Resistors				D25579		Numerals Dial (Specify Number)	.25
C20061-223	R1	Resistor, 22 K ½W. 20%	.10	D25556-1		Pointer, Ivory	1.50
C20061-225	R2	Resistor, 2.2 meg. ½W. 20%	.10	D25556-2		Pointer, Willow Green	1.50
C20061-471	R3	Resistor, 470 ½W. 20%	.10	D25556-3		Pointer, California Tan	1.50
C20061-334	R4	Resistor, 330K ½W. 20%	.10	D25556-4		Pointer, Ebony	1.50
C20061-151	R5	Resistor, 150 ½W. 20%	.10	Misc.			
C20120-121	R11	Resistor, 120 ½W. 10%	.10	D25572	L1	Antenna loop & rear cover	1.50
C20061-150	R12	Resistor, 15 ½W. 10%	.10	B23456		Antenna loop mtg. brkt.	.10
C20070-121	R13	Resistor, 120 1W. 10%	.10	E25565		Carton & filler	.75
C20070-122	R14	Resistor, 1200 1W. 10%	.10	AC24210-1	L2	Coil, Oscillator	.60
C20061-470	R15	Resistor, 47 ½W. 20%	.10	C20138-16		Cord, line	.45
C20061-475	R7	Resistor, 4.7 meg. ½W. 20%	.10	A19351		Dial light bulb No. 47	.20
C20061-222	R8	Resistor, 2200 ½W. 20%	.10	A25481-2		Dial light socket	.35
Cabinet parts				A20243-3		Socket, wafer, center pin shielded	.15
A25579-1		Arvin Name	.20	A20243-1		Socket, wafer, plain	.15
R25546-1		Cabinet, Ivory	4.20	C23467		Speaker 5"	3.00
R25546-2		Cabinet, Willow Green	4.20	AD25574-1		Speaker brkt. & pointer shaft ass'y.	1.15
R25546-3		Cabinet, California Tan	4.20	A40474		Spring clip mtg. I.F. transf. (5 for)	.10
R25546-4		Cabinet, Ebony	4.20	C21797-16	T1, T2	Transformer I.F.	1.20
AD25559-1		Baffle ass'y. with cloth & numerals	3.10	A19361		Tuning shaft hair pin clip (10 for)	.15
		Ivory (Ch—gold cloth)		AC23464-1	T3	Transformer output	1.25
AD25559-2		Baffle ass'y. with cloth & numerals	3.10	C25576	R6	Volume control 1 meg. ¼W. 20%	1.00
		Willow Green (green—gold cloth)		A25575		Tuning shaft	.30

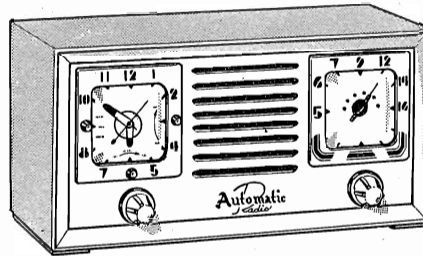

ELECTRICAL SPECIFICATIONS

Power Supply	115 to 125 volts 60 cycles AC only	This receiver contains the following tubes:
Frequency Range	538 to 1650 KC	1-12BE6Mixer
Speaker5 inch PM	1-12BA6I.F. Amplifier
Power Output	1.5 watts maximum	1-12AT6Detector-AVC-1st Audio
		1-50C5Power Output
		1-35W4Rectifier

SERVICE NOTES

Voltages taken from different parts of the circuit to the common ground above chassis are measured with volume control in maximum position, all tubes in their sockets, no signal applied, and with a voltmeter having a resistance of 20,000 ohms per volt. These voltages are shown on the voltage chart on the back of this sheet. All voltages should be measured with an input voltage of 118 volts AC only. To check for open bypass condensers, shunt each condenser with a known good condenser of the same capacity and voltage rating.

ALIGNING INSTRUCTIONS

Never attempt any adjustments on this receiver unless it becomes necessary to replace a coil or transformer, or the adjustments have been tampered with in the field. Always make certain that other components, such as tubes, resistors, condensers, etc., are normal before proceeding with re-alignment. If re-alignment is necessary follow the instructions given below under the heading "Alignment Procedure." After the re-alignment has been completed, repeat the procedure as a final check.

To remove the chassis for servicing, remove the three chassis screws from the bottom of the cabinet and remove the cabinet back, volume control knob and tuning knob. Remove the bracket securing the clock to the cabinet and slide out the chassis and clock.

ALIGNMENT PROCEDURE

- Volume Control — Maximum, all adjustments.
- No signal applied to antenna.
- Power Input — 115 to 125 volts, 60 cycle AC.
- Connect dummy antenna in series with output lead of signal generator.
- Connect ground lead of signal generator to common ground above chassis.
- Repeat alignment procedure as a final check.

- The following equipment is necessary for proper alignment:**
- Signal generator that will provide the test frequencies as listed, modulated 400 cycles, 30%.
- Non-metallic screwdriver.
- Output meter.
- Dummy antenna — .1 MFD condenser.
- For alignment points refer to Schematic Diagram

Dial Setting	Generator Frequency	Dummy Antenna	Generator Connection	Trimmer Reference	Trimmer Adjustment	Trimmer Function
1. Fully open	455 KC	.1 MFD	12BE6 Grid	L3 Top & Bot.	Maximum	Output I.F.
2. Fully open	455 KC	.1 MFD	12BE6 Grid	L2 Top & Bot.	Maximum	Input I.F.
3. Fully open	1650 KC	.1 MFD	12BE6 Grid	CV2	Maximum	Oscillator
4. Tune in signal from generator	1400 KC		Loosely couple signal generator to "Magna Loop"	CV1	Maximum	Antenna R.F. Trimmer

PARTS LIST

Schematic Diagram Reference	Part No.	Description	List Price
CONDENSERS			
C1	CC200	100 MMFD Ceramic	\$.25
C2	C208	.1 MFD 400 volt	.35
C3	CC500	500 MMFD Ceramic	.25
C4	CC201	200 MMFD Ceramic	.25
C5, C6, C7	C206	.01 600 volt	.30
C8	C204	.05 400 volt	.35
C9L	C14L	.1 MFD 400 volt con- denser-choke assbly, electrolytic	.50
CE-601	CE-601-U	Dual 50 MFD 150 volt	2.50
CV1, CV2	CV-149	2 section variable	2.75
RESISTORS			
R1	R306	20 K ohm 1/2 watt 20%	.10
R2	R310	2 megohm 1/2 watt 20%	.10
R3	R311	10 megohm 1/2 watt 20%	.10
R4, R9	R307	250 K ohm 1/2 watt 20%	.10
R5	R308	500 K ohm 1/2 watt 20%	.10
R6	R320	150 ohm 1/2 watt 20%	.10
R7	R321	27 ohm 1/2 watt 20%	.10
R8	R314	1.5 K ohm 1 watt 20%	.20
RV-152	RV-152	3/4 megohm volume control	1.00
COILS AND TRANSFORMERS			
L1	L-A51	Magna-Loop Antenna Coil	1.50
L2	1655-16	1st I.F. Transformer	2.00
L3	1655-16	2nd I.F. Transformer	2.00
L4	L201	R.F. Oscillator Coil	1.00
MISCELLANEOUS			
T-47	T-47	Pilot Light	.15
PM-300	PM-300	Speaker, 5" PM, includes Output Transformer	6.40
	H-152B	Blond Cabinet	10.50
	H-152M	Mahogany Cabinet	9.50
	H-164B	De Luxe Blond Cabinet	12.00
	H-101	Knob	.20
M	C57G27	Electric Clock	9.00
M	C57G84	Electric Clock	10.00
AR-152	AR-152	Appliance Socket	.40
DIAL PARTS			
	H-102	Dial Pointer	.35
	H-103	Dial Pulley	.05
	H-152	Dial Window	.30
	H-104	String, Dial Drive Spring, Dial Drive	.05
	H-105	String, Dial Drive Tension	.10

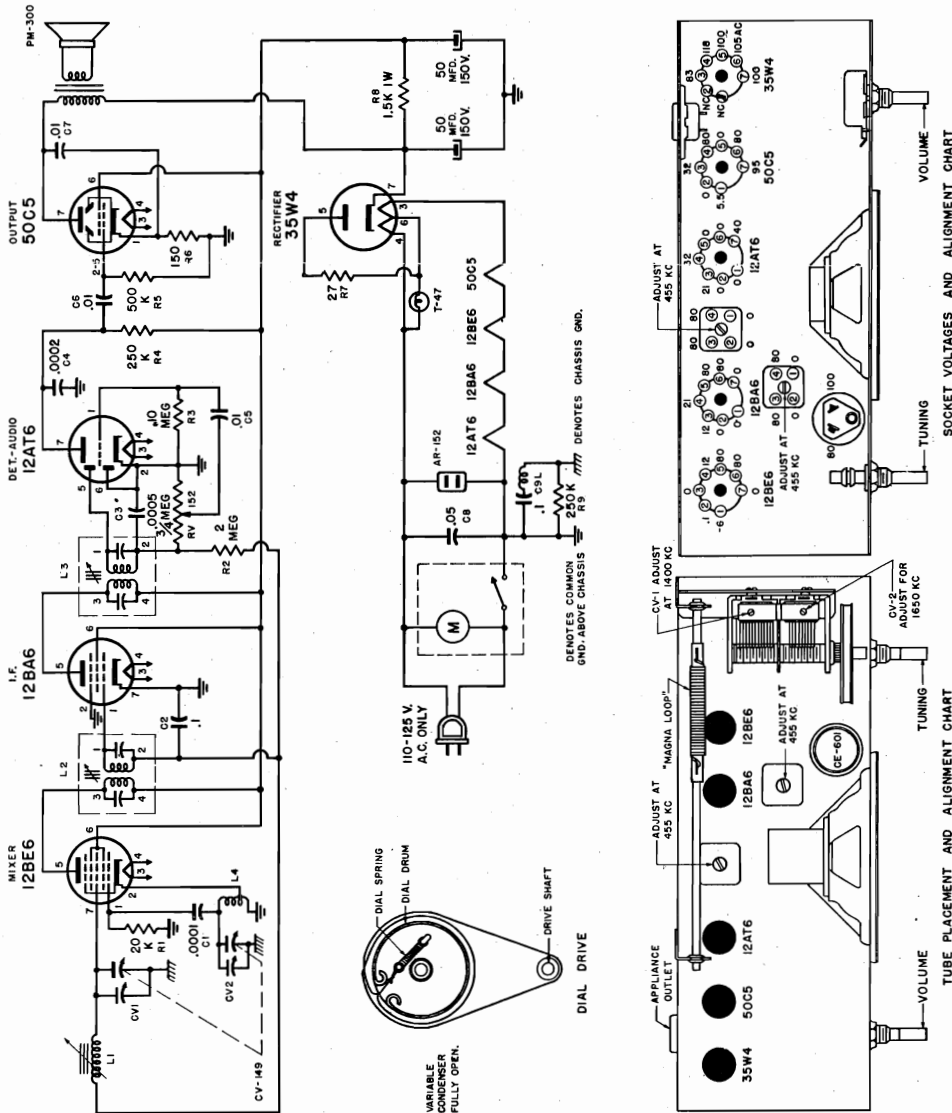

Model 753F—"The Cascade"—Cherry Cabinet
 Model 753M—"The Marion"—Mahogany Cabinet
 Model 753W—"The Bedford"—Blond Oak Cabinet

SPECIFICATIONS

POWER REQUIREMENTS:

105-120 volts, 60 cycles A.C. only

POWER CONSUMPTION:

Radio and Clock--35 Watts
 Appliance outlet may be used for any electrical appliance rated at 1100 Watts or less.

RADIO I.F. FREQUENCY:

455 KC

RADIO TUNING RANGE:

540-1620 KC

MAXIMUM POWER OUTPUT:

1 Watt undistorted

LOUDSPEAKER:

4" PM

TUBE COMPLEMENT:

V1 12BE6 Converter

V2 12BA6 I.F. Amplifier

V3 12AT6 Demodulator, AVC, and
 1st Audio Amplifier

V4 50C5 Audio Output

V5 35W4 Rectifier

Special Switch Permits Use of Automatically Controlled Appliance Outlet without Turning on Radio.

Realizing the importance of prompt dissemination of service information to the field, this first in a series of newsletters is released. We suggest that the information furnished in this and subsequent releases be passed on to your dealers and service organizations to assist them in their service problems on our products. These releases will, if properly filed, serve a ready reference for your future use.

Model 753 Clock Radio

If set remains on regardless of position of Off-Auto-On switch, check to see that production jumper is still connected across the lines to this switch. The jumper must be removed for proper switch operation.

Failure of oscillator, when receiver is tuned to the low end of the band, may be corrected by substituting a lead 6 3/4" in length for the original one connecting pin #7 of the 12BE6 to the antenna section of the gang condenser. Sets involved will only be those with serial numbers from 10,001 to 11,550.

Switch Adjustment for the Clock Radio

When this switch fails to operate in the "Auto" or "On" position it can be adjusted in the following manner.

1. Locate the slotted adjusting screw which is on the back of the clock just to the left of the lower mounting bolt for the switch assembly.
2. With a small screw driver turn this screw in the clockwise direction approximately 3/4 of a turn. (Take precautions not to over adjust this screw, to do so will not permit the switch to operate in the "Off" position.)

CAUTION: For any further adjustments or repairs to the clock mechanism it will be necessary to disassemble the clock from the radio completely and send it to the nearest Sessions clock repair station. Information concerning the repair stations locations may be obtained from the Bendix distributor.

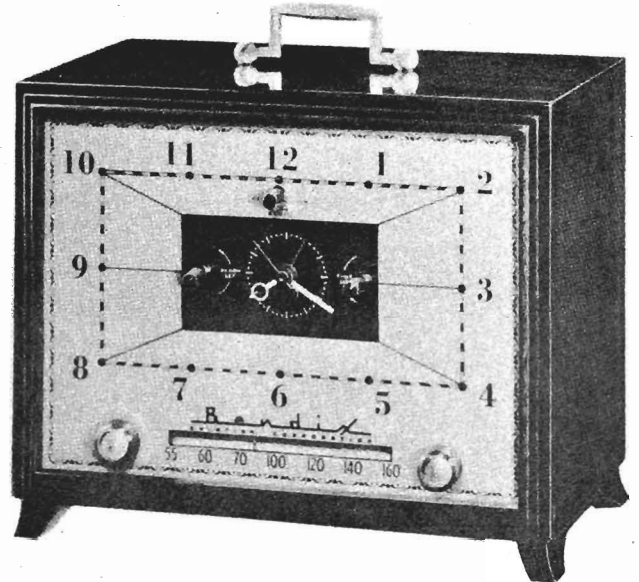

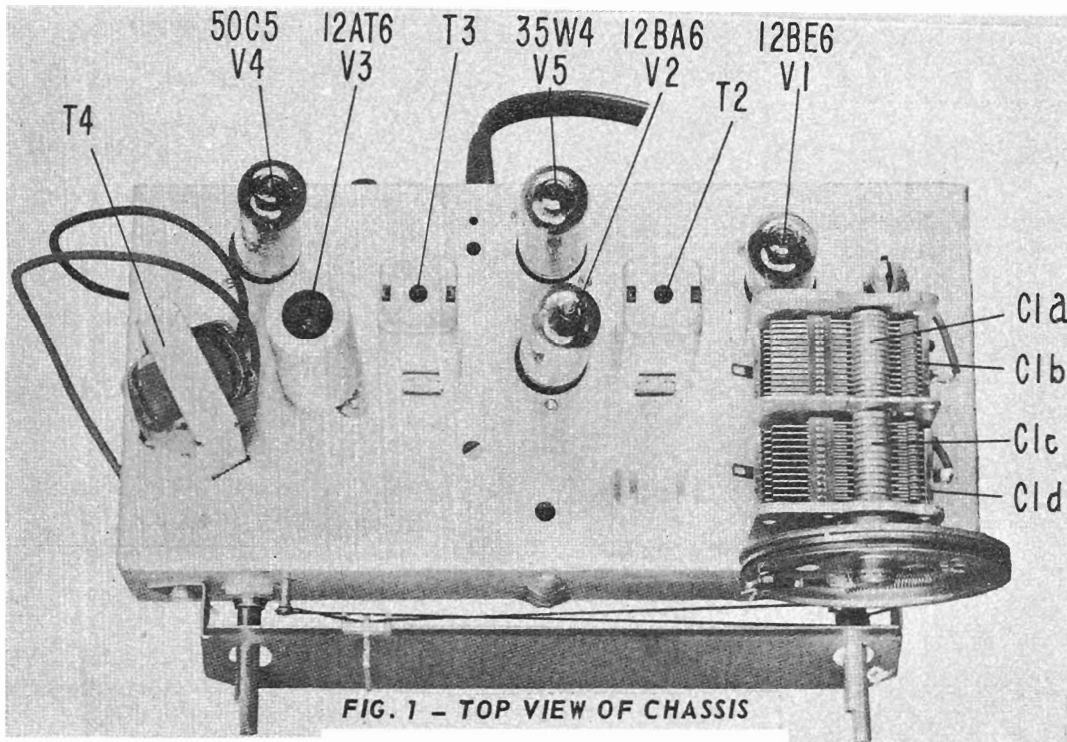
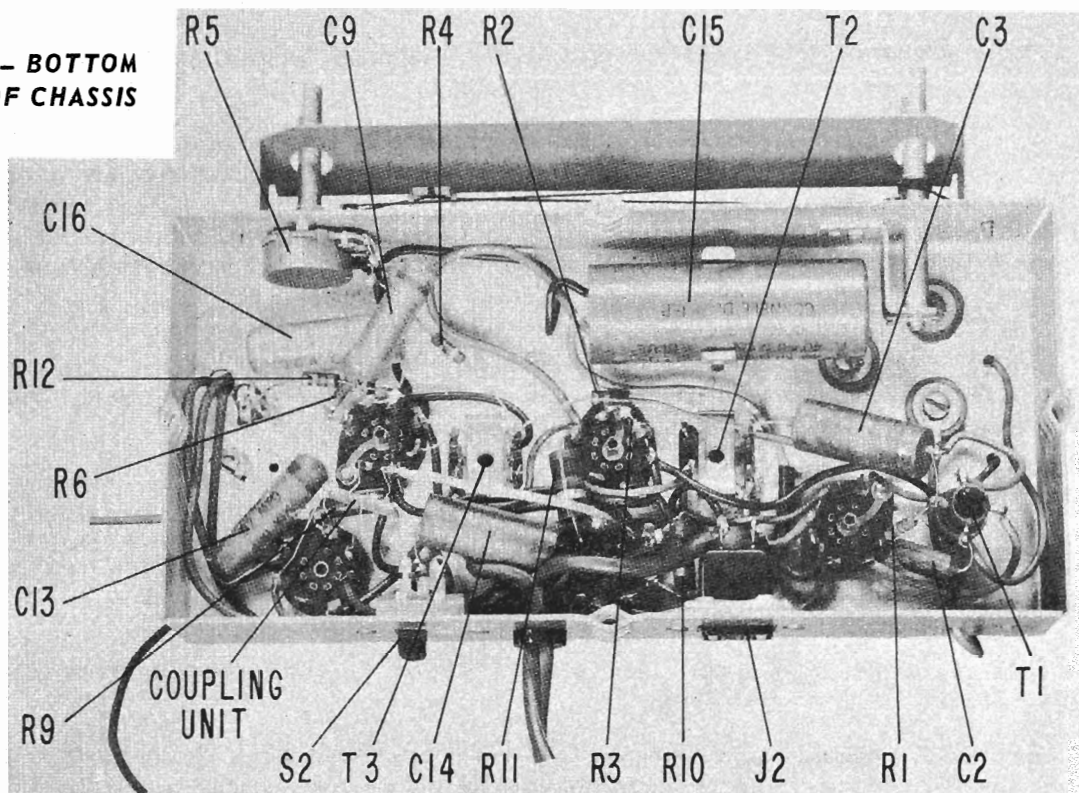

FIG. 1 - TOP VIEW OF CHASSIS

FIG. 2 - BOTTOM VIEW OF CHASSIS



Removal of the Clock and Switch Assembly

1. Remove the two top screws from the cabinet back.
2. Unscrew the four chassis bolts and take the radio from the cabinet.
3. Remove the clock mounting board by turning the four clip springs around the outer edge in either direction with a screw driver until they are free from the grooves in the top and sides of the cabinet. (Since this mounting board also holds the dial glass in place precautions must be taken to prevent it from falling and breaking.)

4. The clock is dismantled from the mounting board by turning the four clip springs located around the inside opening with a screw driver until they are free from the clock face.
5. Unsolder the three leads (Brown, Black and Blue) from the radio.
6. Securely pack the assembly for shipment to the nearest Sessions clock repair station.
7. In order to reassemble the clock in the radio cabinet, just reverse the procedure outlined above making sure that the three leads are fed through the mounting board before they are connected to their respective points within the radio chassis.

ALIGNMENT PROCEDURE

An isolation transformer should be used between the AC power line and the receiver for protection of any test equipment that must be operated from the same power line.

Turn tuning gang fully closed and set pointer

directly over reference mark on dial (see Fig. 4). Volume control should be set at maximum position. Keep output of signal generator as low as practical at all times and make adjustments with an insulated alignment screw driver.

Signal Generator Coupling	Signal Generator Frequency	Dial Setting	Connect	Adjust	Remarks
High side through .01 to pin 7 (Grid) of 12BE6 Low side to B-	455KC	Max. to right	Output Meter across voice coil	T3, T2	Adjust in order given for max. meter reading
A loop fashioned of several turns of wire radiating the signal into the receivers antenna	1640	To the correct dial marking See Fig. 4	Same	C1d	Adjust for max. meter reading
Same	1475	To correct dial marking See Fig. 4	Same	C1b	Adjust for max. meter reading

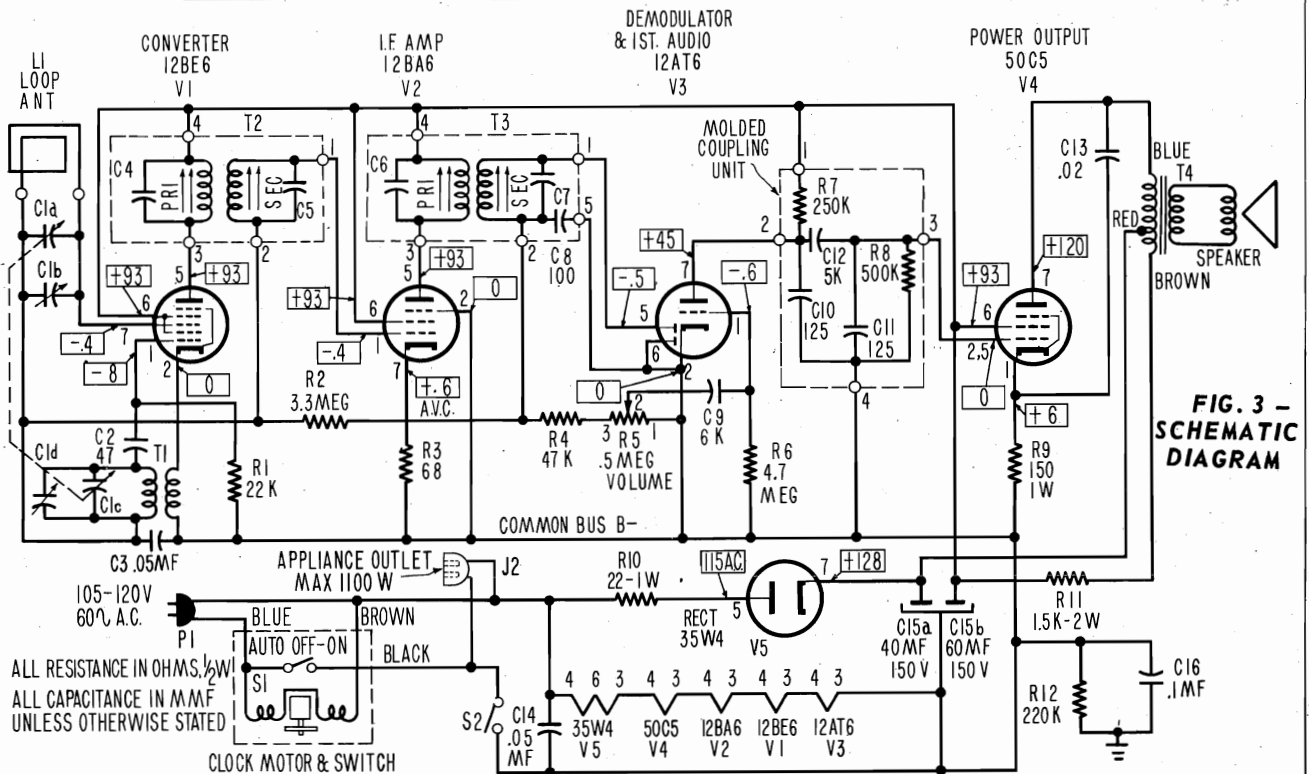

FIG. 3 - SCHEMATIC DIAGRAM

MODELS 753F, 753M, 753W

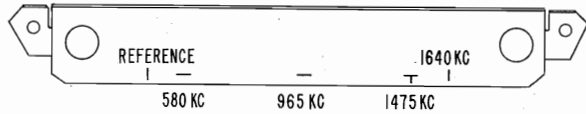

FIG. 4 - DIAL BACK PLATE REFERENCE MARKS

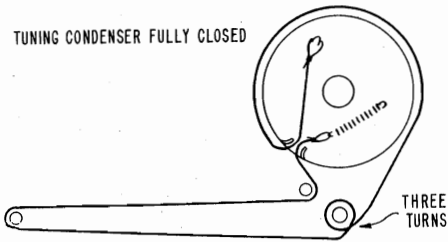

FIG. 5 - DIAL CORD DIAGRAM

PARTS LIST

ELECTRICAL COMPONENTS

PART NUMBER	SYMBOL NUMBER	DESCRIPTION	LIST PRICE
RC23A223M	R1	RESISTOR-Comp. 22K 1/2W ±20%	.10
RC23A335M	R2	RESISTOR-Comp. 3.3 Meg 1/2W ±20%	.10
RC23A680M	R3	RESISTOR-Comp. 68 ohms 1/2W ±20%	.10
RC23A473M	R4	RESISTOR-Comp. 47K 1/2W ±20%	.10
CH262022-5	R5	POTENTIOMETER-.5 Meg 1/4W ±30%, Volume	.80
RC23A475M	R6	RESISTOR-Comp. 4.7 Meg 1/2W ±20%	.15
RC24A151K	R9	RESISTOR-Comp. 150 ohms 1W ±10%	.15
RC24A220M	R10	RESISTOR-Comp. 22 ohms 1W ±20%	.15
RC25A152M	R11	RESISTOR-Comp. 1.5K 2W ±20%	.20
CH274249-1	R7	MOLDED COUPLING UNIT-500K 1/5W } -125 mmf 5K }	.54
	R8		
	C10, C11, C12		
LH260016	C1a, b, c, d	CAPACITOR-Variable	2.70
CM22A470M	C2	CAPACITOR-Mica 47 mmf ±20% 500V	.25
CH267001-503	C3, 14	CAPACITOR-Tub. Paper .05 mfd ±20% 400V	.29
CH267003-602	C9	CAPACITOR-Tub. Paper .006 mfd +40% -20% 600V	.24
CH267001-203	C13	CAPACITOR-Tub. Paper .02 mfd ±20% 400V	.26
CH267013-2	C15a, b	CAPACITOR-Electrolytic (40-60, 150V)	1.20
CH267001-104	C16	CAPACITOR-Tub. Paper .1 mfd ±20% 400V	.38
LH259151-1	T1	TRANS. ASSY.-Oscillator	.83
CH259038-1	T2, C4, 5	TRANS.-I.F. Input	1.42
LH259152-1	T3, C6, 7, 8	TRANS.-I.F. Output	1.56
LH265062-1	T4	TRANS.-Audio Output	1.89
NH274248		TIMER ASSY.-Sessions Clock Co.	7.50
CH268910-6	P1	CORD-Power (#16 wire)	.70
LH251234-1		BACK & LOOP ASSEMBLY	1.20
LH256017-3		SPEAKER-4" PM	4.00
CH270629-1		POINTER	.15
AH266055	J2	RECEPTACLE-2 contacts "Appliance Outlet"	.29
AH258033	S2	SWITCH-Slide - S.P.S.T. "Radio Off-On"	.21

CABINET COMPONENTS

PART NUMBER	753M	753W	753F	DESCRIPTION	LIST PRICE
LH257636-1	X	X	X	DIAL-Glass	2.50
CH269081-1	X	X	X	KNOB-Clock Controls	.29
LH269082-1	X	X	X	KNOB-Radio Controls	.28
RH255122-1	X			CABINET-Mahogany	8.10
RH255122-3		X		CABINET-Blond	8.55
RH255122-4			X	CABINET-Cherry Wood	8.55

TUBES

LIST PRICE			LIST PRICE		
V1	12BE6	1.90	V4	50C5	2.00
V2	12BA6	1.90	V5	35W4	1.30
V3	12AT6	1.55			

ALL PRICES ARE SUBJECT TO CHANGE WITHOUT NOTICE

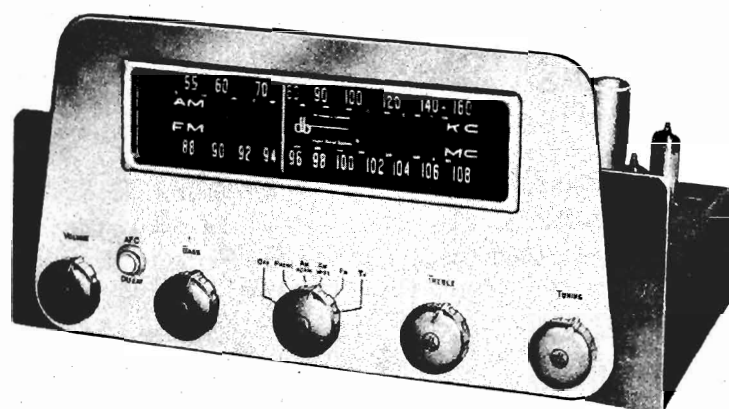
MODEL R701,
AM-FM Tuner

R701 SPECIFICATIONS

POWER CONSUMPTION: 60 watts, 117 volts, 60 cps.

TUBES: 1-6BK7-A, 1-6AB4, 4-12AT7, 2-6BA6, 1-6BE6, 3-6AU6, 1-6AL5, 1-6X4
(14 tubes including rectifier).

SENSITIVITY: FM: Input required for 30 db quieting: 3 microvolts.
AM: 5 microvolts.

FREQUENCY RANGE: FM: 88-108 MC.
AM: 530-1650 KC.

HUM & NOISE: FM, AM: -65 db below 100% modulation.
TV, PHONO: -65 db below 2 volts.

AUDIO OUTPUT: 3 volts at 6000 ohms.
DISTORTION: 3 volts at .2%.

tone CONTROL: At 60 cycles: 17 db boost, 19 db cut.
At 10,000 cycles: 15 db boost, 18 db cut.
At 15,000 cycles: 17 db boost, 21 db cut.

FREQUENCY RESPONSE: FM: 20-20,000 cps \pm .5 db.
AM: 20-4,000 cps \pm .5 db normal position.
20-7,500 cps \pm .5 db Hi-Fi position.

PHONO PREAMPLIFIER: 35 db gain and 21 db equalization at 30 cycles.

AM SELECTIVITY: Normal: at 8 KC: 6 db.
Hi-Fi: at 15 KC: 6 db.

FM SELECTIVITY: 180 KC: 6 db.
Discrimination peak to peak separation: 375 KC.

ANTENNA INPUT: AM: Low impedance loop or high impedance external antenna.
FM: 300 ohms.

CONTROLS: 1. Volume, 2. Bass, 3. Function Switch (Off, phono, AM normal, AM Hi-Fi, FM, TV), 4. Treble, 5. Tuning.

FM DRIFT: \pm 20 KC with AFC defeated.
 \pm 3 KC with AFC in.

SIZE: 15" x 8 1/2" x 9".

SHIPPING WEIGHT: 17 lbs.

CONNECTIONS: All connections are made at the rear of the chassis.

Power input: AC power is supplied to the tuner through the attached line cord. Plug this cord into an AC receptacle.

AC power output: The two AC receptacles are supplied with AC power when the tuner is turned on. By plugging other units of the reproducing system into these receptacles, power control can be centralized.

Antenna: All antenna connections are made to the numbered terminal strip. In areas of normal signal strength a loop antenna, made from the cable supplied with the tuner, will provide good reception with low noise on both the AM and FM bands. Tack the cable around the rear of the cabinet to form a single or double turn loop of the largest possible cross-sectional area. Connect the two lead lugs to terminals 1 and 4, and the shorting jumper between terminals 2 and 3.

In areas where FM signals are weak, an outdoor FM antenna may be used in conjunction with the indoor loop for AM. Connect an FM antenna to terminals 1 and 2, the shorting jumper between terminals 2 and 3, and the loop to terminals 3 and 4.

In AM fringe areas an external antenna may be used to increase AM sensitivity. Connect the AM antenna to terminal 4, disconnect the jumper from terminals 2 and 3, and connect the FM antenna to terminals 1 and 2.

Audio input: The signals from a TV set and a record player can be connected to the tuner at the jacks marked TV and PHONO. When the connections are made, the signal to be delivered to the amplifier is selected by the control knob on the front of the chassis.

Audio output: The amplifier used with the tuner is to be connected to the jack marked OUTPUT. The output of the tuner may be simultaneously recorded without affecting the operation of the amplifier by connecting a recorder to the DETECTOR jack. In order to reduce the possibility of hum pickup, the connections to the tuner should be made with single conductor shielded wire, not exceeding 7 feet in length.

CONTROLS: **Selector:** Turning the selector knob from OFF to PHONO:

- 1) Supplies power to the A.C. receptacles on the rear of the chassis.
- 2) Supplies power to warm up the tuner tubes.
- 3) Supplies signal from the record player to the OUTPUT and DETECTOR jacks.

**MODEL R701,
AM-FM Tuner**

Further movement of the selector knob selects AM NORM, AM HI-FI, FM, and TV. For most programs the AM NORM position will provide reception with a minimum of background noise and interference. The AM HI-FI position enables the listener to take full advantage of the high-fidelity programs broadcast by some AM stations.

AFC DEFEAT: If, while attempting to tune in a weak FM station, the tuner "jumps" to a stronger adjacent station, hold down the pushbutton marked AFC DEFEAT, located on the front of the chassis. This will disconnect the Automatic Frequency Control and permit tuning of the weak station. Release the button when the station is tuned in. The AFC will then center the station and hold it in tune.

If recordings are being made, it is recommended that the tuner be adjusted to the exact frequency of the station being recorded. This may be accomplished by defeating the AFC as described above, tuning the station to its exact frequency, and releasing the AFC DEFEAT pushbutton.

PREAMPLIFIER: A preamplifier is included in the Model R701 to supply the additional amplification and equalization needed when a magnetic type phono pickup, such as the G.E. cartridge is used. Since the preamplifier is not required when the phono pickup is a crystal type, it can be disconnected by the switch at the rear of the chassis. Place this switch in the MAG position when using a magnetic pickup, and in the CRYST position when using a crystal pickup.

SERVICE: The tuner should not require any service other than a periodic check of vacuum tubes. The critical adjustments all have a high degree of stability over long periods of time and should not be tampered with. The adjustment of a modern high fidelity receiver such as the R701 should be made by competent, experienced personnel with proper visual alignment equipment. Ordinary meters or aural methods are in general unsatisfactory for alignment.

VOLTAGE CHART

TUBE	FUNCTION	PIN 1	PIN 2	PIN 3	PIN 4	PIN 5	PIN 6	PIN 7	PIN 8	PIN 9	
6BK7A	FM RF	95	0	.7	0	6.3 AC	95	0	0	0	
6AB4	FM MIXER	95	0	6.3 AC	0	0	.8 *	0	-	-	
12AT7	FM OSC & AFC	92	-1 *	0	6.3 AC	6.3 AC	96	0	1	-	
6BA6	AM RF	-.7	0	6.3 AC	0	75	75	0	-	-	Switch in AM position
6BE6	AM MIXER	-.9	0	6.3 AC	0	75	75	.7	-	-	
6BA6	1st IF	-.7	0	6.3 AC	0	68	68	0	-	-	
6AU6	2nd IF	0	0	6.3 AC	0	86	86	5.5	-	-	
6AU6	1st LIM	-.5	0	6.3 AC	0	30	30	0	-	-	
6AU6	2nd LIM	-1.5	0	6.3 AC	0	25	25	0	-	-	
6AL5	DISCRIMINATOR	-.5	-3	6.3 AC	0	0	0	-.4	-	-	
12AT7	AM DETECTOR	-.6	-.6	0	6.3 AC	6.3 AC	150	12	16	0	Switch in AM position
12AT7	AUDIO AMP	83	20	30	6.3 AC	6.3 AC	150	30	55	0	
12AT7	PHONO PREAMP	52	0	.9	6.3 AC	6.3 AC	43	-.5	0	0	
6X1	RECT	220 AC	-	6.3 AC	0	3.5 AC	220 AC	220	-	-	

- Note:
1. All measurements taken with VTVM
 2. Bandswitch to be in FM position unless otherwise noted
 3. Input voltage to be 117 v 60 cycles AC
 4. Readings to be within 15% of chart except readings marked with asterisk to be within 50%
 5. Set must be tuned off station for voltage readings

MODEL R701,
AM-FM Tuner

ALIGNMENT PROCEDURE

Note: Use insulated screwdriver for adjustment

Step No.	Bandswitch Setting	Generator Frequency	Generator Modulation	Signal Input Point	Indicator	Indicator Connection Point	Dial Setting	Adjust	Remarks
AM ALIGNMENT									
1	AM NORM	455 Kc	30% AM	6BE6 Pin #7	AC VTVM or PA + output meter	Audio output	-	2 AM IF transformers	For maximum output
2	same	600 Kc	same	AM Antenna terminal thru 200 mmf condenser	same	same	600 Kc	BC osc coil BC RF coil BC antenna coil	same
3	same	1500 Kc	same	same	same	same	1500 Kc	BC osc. trimmer BC IF trimmer BC antenna trimmer	same. Repeat steps 2 and 3
FM ALIGNMENT									
4	FM	10.7 Mc	300 Kc deviation FM at 60 cycles	6BA6 IF AMP Pin #1	DC VTVM + Oscilloscope	"A" on schematic through 100 K	-	All FM IF transformers	For maximum gain and symmetry
5	same	same	same	same	same	"B"	-	Discr. transformer + 2nd LIM coil	For balanced discriminator S pattern of max. amplitude
6	same	106 Mc	same	FM antenna terminal through 300 ohms	same	"A" on schematic through 100 K	106 Mc	FM osc + RF + Antenna trimmer	For maximum output
7	same	90 Mc	same	same	same	same	90 Mc	-	Check for tracking
8	AM NORM	10 Kc	none	"C" on schematic	AC VTVM	Audio output	-	10 Kc whistle filter	For maximum dip

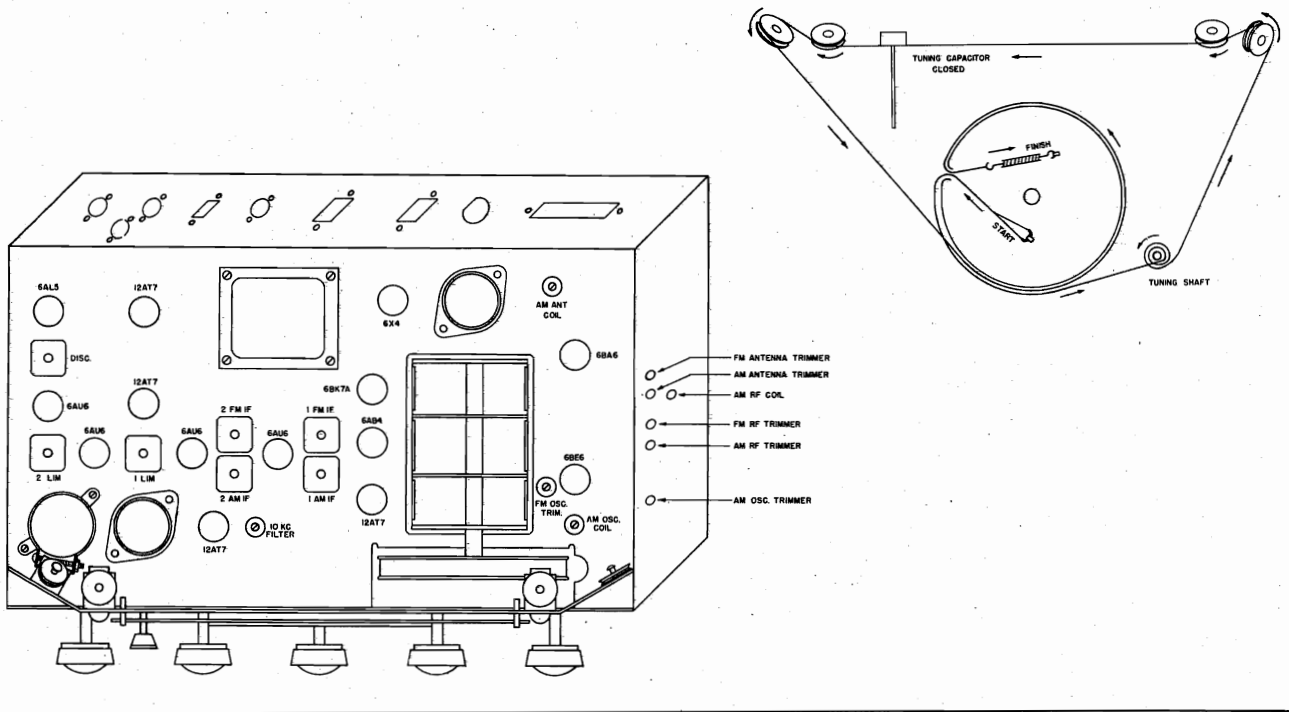

MODEL R701,
AM-FM Tuner

INSTALLATION INSTRUCTIONS: Installation of the R701 tuner should be carefully planned, specifically with the following in mind:

- 1) Ventilation: Adequate air circulation will prolong the life of the tuner. This can best be accomplished by providing air vents near the top and bottom of the cabinet enclosure.
- 2) Ease of manipulation: Tuner should be mounted so that the dial can be read easily; control knobs should be kept clear of any cabinet projections.
- 3) Ease of accessibility: Tuner should be mounted in such a way that it may be easily removed for servicing. Tubes, pilot lights and connections at the rear of the chassis should be readily accessible.
- 4) Loop antenna: If a loop antenna is used, it should be kept as far as possible from any metal parts to insure good signal pick up.
- 5) Tuner position: Tuner may be mounted either horizontally or vertical

ASSEMBLY INSTRUCTIONS:

- 1) Cut out front panel in accordance with attached front panel template.
- 2) Mount 4 shockmounts on side of chassis as indicated by dotted sketch on front panel template.
- 3) Mount the escutcheon in the opening of the escutcheon plate. Fasten securely by bending the tabs at the top and bottom edges of the escutcheon firmly over the escutcheon plate.
- 4) Place the escutcheon assembly on the mounting surface, carefully aligning all cutouts. Fasten to the mounting surface with two #2 woodscrews as indicated on the template. Bend the tabs extending from the protruding angle bracket of the escutcheon plate firmly over the mounting surface.
- 5) Move the tuner forward on the mounting surface until the glass dial is 1/16" behind the protruding bracket. Check centering of shafts and dial in the cutouts. Mark with an awl the position of 4 holes on the chassis mounting board through the center of the shock mounts.
- 6) Cut out the 4 marked holes with a 1/4" drill, and fasten the tuner chassis by inserting the #10 machine screws from the bottom of the mounting board.
- 7) Mount knobs on shafts and make all rear connections.

MATERIAL SUPPLIED WITH TUNER:

- 5 knobs
- 1 escutcheon
- 1 escutcheon plate with two #2 woodscrews
- 4 phono plugs
- 4 shockmounts with 8 self-tapping screws
- 4 #10 machine screws
- 1 loop antenna cable

MODEL R701,
AM-FM Tuner

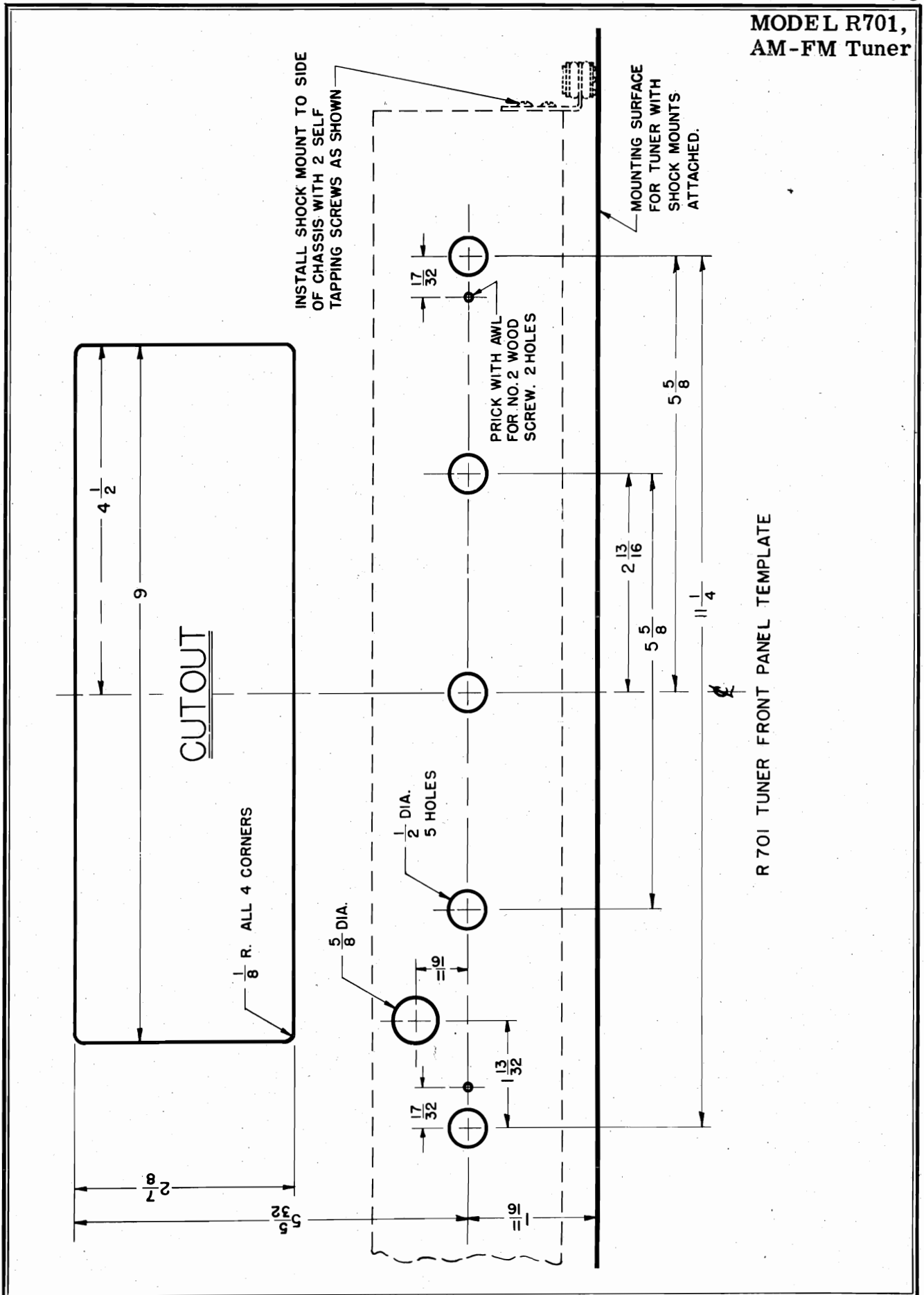

R 701 TUNER FRONT PANEL TEMPLATE

ALIGNMENT DATA

I. F. Alignment:

T1 and T2 at 455 Kc - tuning condenser plates completely closed. Connect generator with modulated RF signal to pin 8 - mixer grid 12SA7. Keep output of signal generator as low as possible so as not to overload IF amplifier or audio amplifier stages, volume control at maximum. Peak by audio signal from speaker, or an A. C. voltmeter connected across speaker.

R. F. Alignment:

1. Set pointer with condenser plates completely closed so that it is horizontal.
2. Turn tuning drive so that pointer reads 1400 KC.
3. Adjust tuning condenser trimmer C_O for maximum response. Volume control at maximum, modulated signal from generator as small as possible.
4. Adjust C_T for maximum response as in step 3.
5. Repeat if necessary steps 1-5.

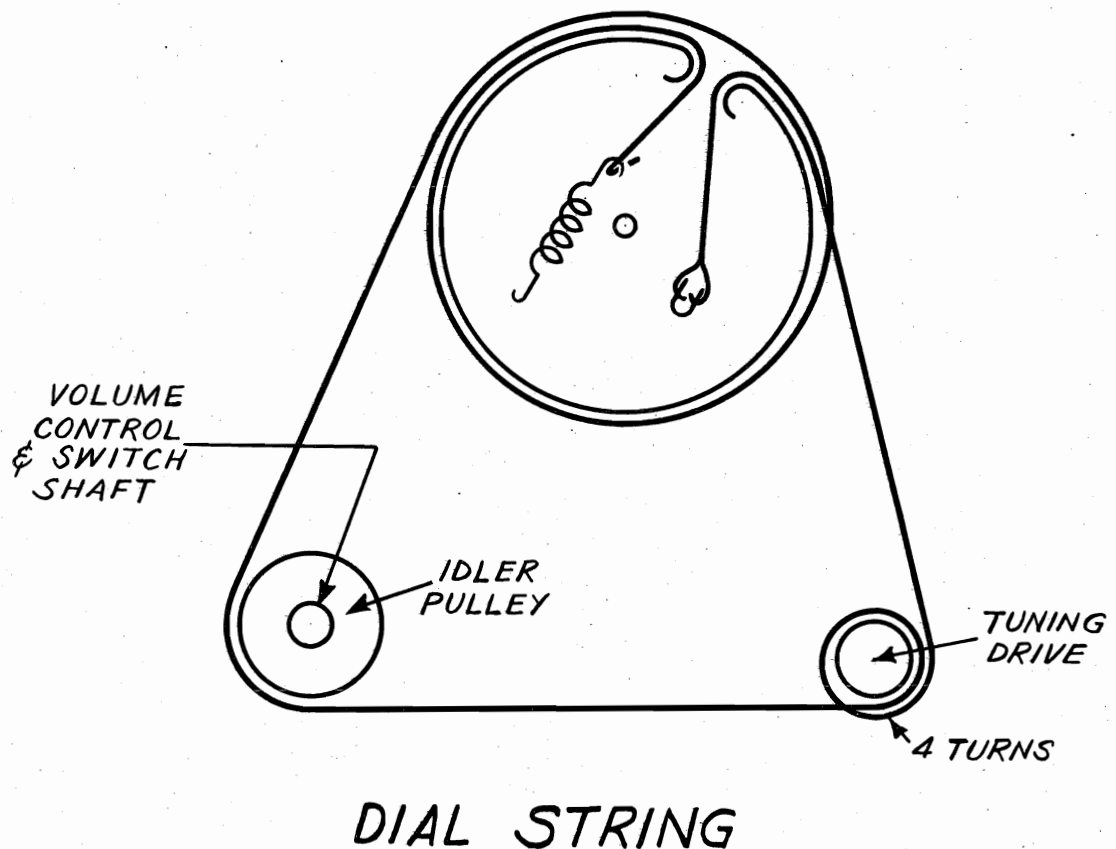

MODELS 533, 534,
535, 536, 530 Series

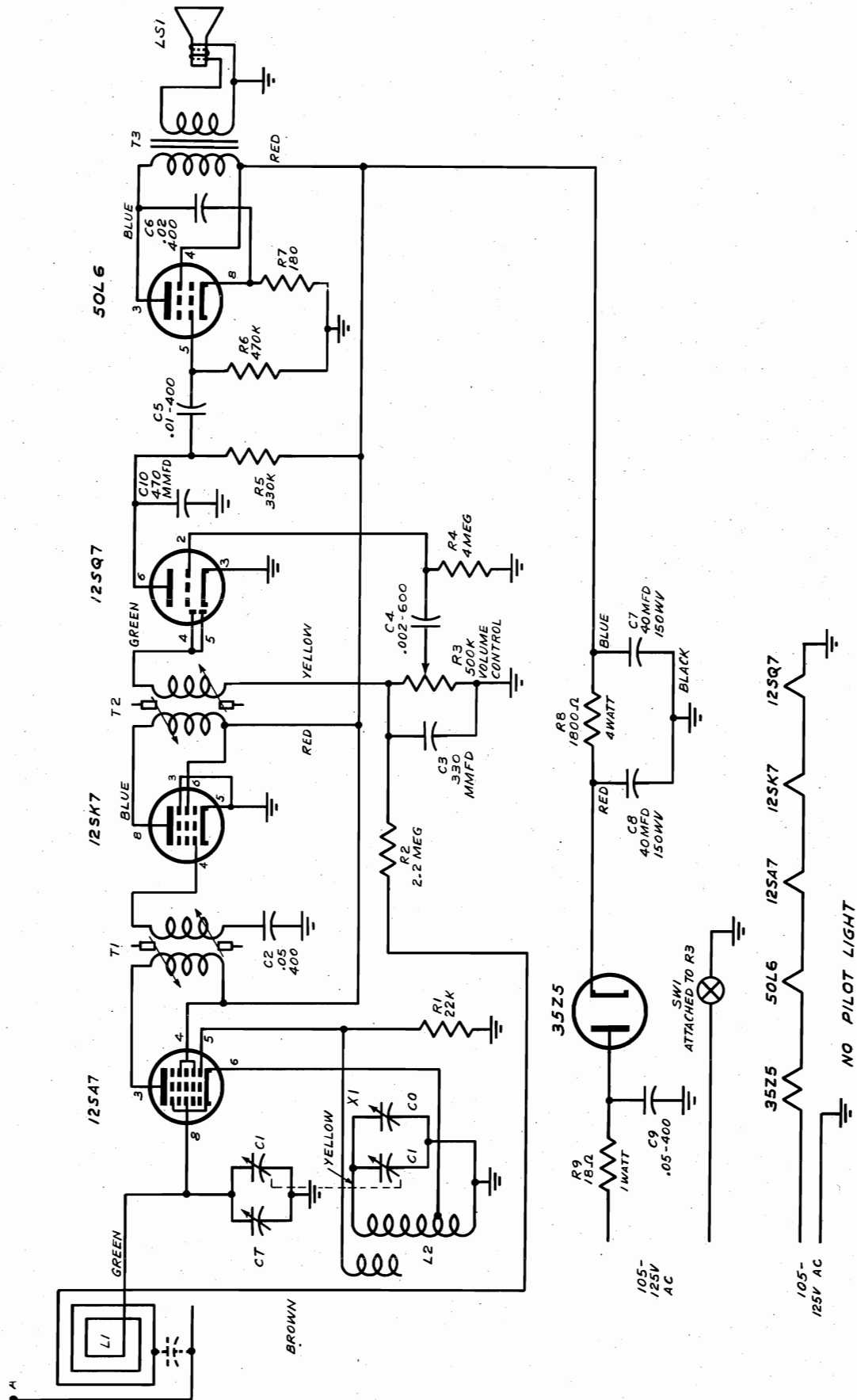

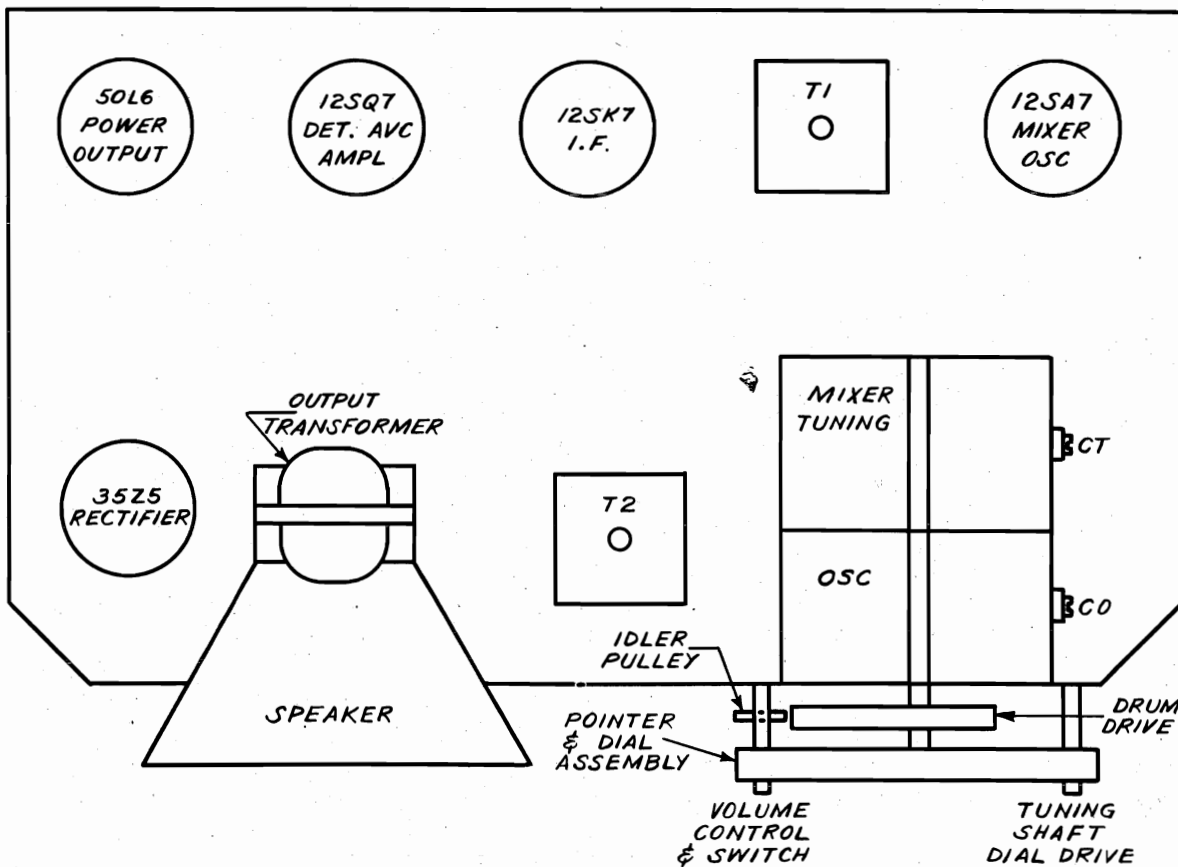

TOP VIEW

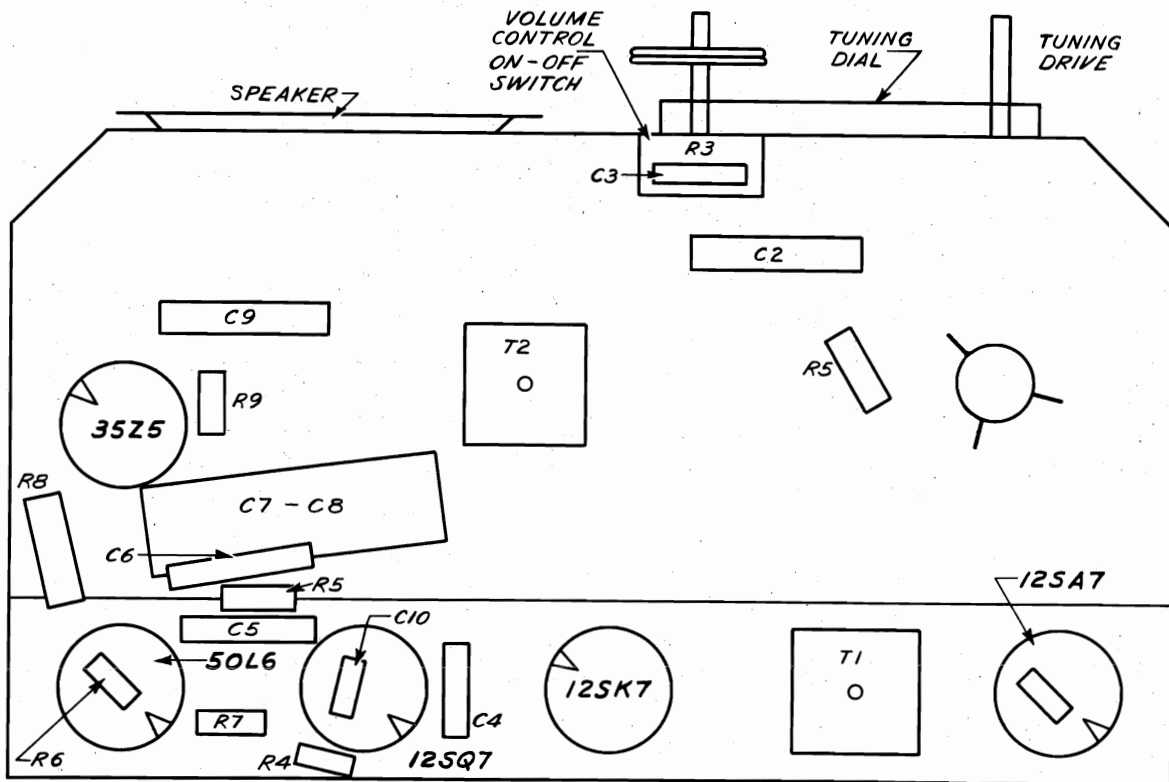

BOTTOM VIEW

MODELS 533, 534,
535, 536, 530 Series

<u>SCHEMATIC LOCATION</u>	<u>PART NUMBER</u>	<u>DESCRIPTION</u>
	1686	Cabinet (Walnut or Ivory)
C1	PE 196-98	Capacitor, Paper, .002 MFD 400V
C2	1666	Capacitor, Variable
C5	PE 191-15	Capacitor, Mica 47 MMF
C6	PE 191-31	Capacitor, Mica 220 MMF
C7	PE 196-112	Capacitor, Paper .05 MFD 400V
C8	PE 191-35	Capacitor, Mica 330 MMF
C9	PE 196-97	Capacitor, Paper .001
C10	PE 191-40	Capacitor, Mica 510 MMF
C11	PE 196-107	Capacitor, Paper .01
C12	PE 196-108	Capacitor, Paper .02 MFD 400V
C13	PA 20136	Capacitor, Electrolytic 40-40 #150
C14	PP 19105	Capacitor, Paper .05 MFD 600V
L2	28210	Coil, Oscillator
R5	2471	Control, Volume w/switch
	4275	Dial Crystal
	54172	Drive Shaft Assembly
	39137	Knob (Walnut or Ivory)
L1	28159	Loop Antenna
	4145	Pointer
R1	PE 230-2281	Resistor, 22000 ohm $\frac{1}{4}$ w
R2	PE 230-2325	Resistor, 1,500,000 ohm $\frac{1}{4}$ w
R3	PE 230-2309	Resistor, 330,000 ohm $\frac{1}{4}$ w
R4	PE 230-2333	Resistor, 3.3 megohm $\frac{1}{4}$ w
R6	PE 230-2305	Resistor, 220,000 ohm $\frac{1}{4}$ w
R7	PE 233-2257	Resistor, 2200 ohm 2w
R8	PE 230-2337	Resistor, 4.7 megohm $\frac{1}{4}$ w
R9	PE 232-1107	Resistor, 18 ohm 1w
	18110	Socket, Octel wafer
T3	5868	Speaker w/output transformer
T1	1770	Transformer, 1st. I.F.
T2	3535	Transformer, 2nd. I.F.

CHASSIS C-282, C-284,
C-305, C-318

CHASSIS DESCRIPTION

The C-282 and C-318 are both 11 tube AM-FM Radio Chassis. The C-305 is a 10 tube AM-FM Radio Chassis and the C-284 is an 11 tube chassis designed for reception of AM signals only.

All of these chassis contain push-pull audio output amplifiers which are used for radio and phonograph reproduction and also television sound when the chassis are used in "3-way" combination instruments. The C-282 and C-305 chassis are wired for use of the C-295 Phono Pre-Amplifier Chassis which is used in conjunction with the Model 333A-VR Record Changer employing the Variable Reluctance type pickup. The C-284 and C-318 chassis are wired for use with the Model 333A Record Changer which employs a crystal pickup. In all of the above models, the on-off switch on the radio chassis controls the power source for all functions of the receiver. Volume and Tone controls on the radio chassis also function for phonograph and television as well as radio operation.

NOTE: With the Operation Selector (Band Switch) in the phonograph position, the record changer will automatically shut off the power source to the entire instrument when it has played the last record. When the Operation Selector is then switched to either TV or Radio, the power source will again, automatically, be turned on.

SPECIFICATIONS.

Radio Tuning Range:

AM Band 540 KC to 1620 KC
FM Band 88 MC to 108 MC

Radio IF Frequencies:

AM IF 455 KC
FM IF 10.7 MC

C-282 & C-318 Radio Chassis Tube Complement:

Type	Description
6BA6.....	AM FM RF Amplifier
6RE6.....	AM Converter-Oscillator
12AT7.....	FM Mixer-Oscillator
6BA6.....	1st AM FM IF Amplifier
6BA6.....	2nd AM FM IF Amplifier
6AL5.....	FM Ratio Detector
6SQ7.....	1st Audio AM Detector & Gas Gate
6SQ7.....	Phase Inverter
6V6GT (2).....	Power Amplifiers (Push-Pull)
5Y3GT.....	Full Wave Rectifier

Total: 11 tubes, including one Rectifier.

C-305 Radio Chassis Tube Complement:

Type	Description
6BA6	AM-FM RF Amplifier
6J6	AM-FM Oscillator-Mixer
6BA6	1st AM-FM IF Amplifier
6BA6	2nd AM-FM IF Amplifier
6AL5	FM Ratio Detector
6SQ7	1st Audio, AM Det. & Gas Gate
6SQ7	Phase Inverter
6V6-GT (2).....	Power Amplifiers (Push-Pull)
5Y3-GT.....	Full Wave Rectifier

Total: 10 tubes, including one Rectifier

C-284 Radio Chassis Tube Complement:

Type	Description
6SK7.....	RF Amplifier
6J5.....	Oscillator
6SA7.....	Mixer
6SK7.....	1st IF Amplifier
6SK7.....	2nd IF Amplifier
6SR7.....	Detector
6SQ7.....	1st Audio Amplifier
6SQ7.....	Phase Inverter
6V6 (2).....	Power Amplifiers (Push-Pull)
5Y3GT.....	Full Wave Rectifier

Total: 11 tubes, including one Rectifier.

CHASSIS C-282, C-284, C-305, C-318

C-295 Pre-Amplifier Chassis Tube Complement:

Type	Description
6SC7.....	1st & 2nd Pre- Amplifiers
Speaker (Used for all types of operation).....	12 inch PM
Audio Output.....	12 watts
Power Source.....	105 to 125 volts, 60 cycle AC only

ALIGNMENT INSTRUCTIONS

Equipment Required

AM (broadcast band) IF and RF Alignment

1. Calibrated RF Signal Generator (range, 455KC to 1620KC)
2. Low Range Output Meter

FM (Frequency Modulation) IF & RF Alignment

1. FM Sweep Generator (range 10.7 mc to 108.5 mc)
2. Oscilloscope
3. RF Signal Generator (range 10.7 mc to 108.5 mc)
4. Vacuum tube Voltmeter

AM Alignment (IF & RF)

C-305

- a. Set Operation Selector to AM position
- b. See that the dial pointer coincides with the calibration marks at the extremes of the dial scale.
- c. Connect the Output Meter cable to Speaker socket on receiver.
- d. Turn set on and adjust Volume to maximum.

STEP	CONNECT GENERATOR	SET GENERATOR AT	SET GANG AT	ADJUST	TO OBTAIN
1	Green lead on mixer coil	455KC	fully open	T104, T105 & T108 Top & Bottom slugs	M A X I M U M O U T P U T
2	Loose Couple to loop Ant.	1620 KC	1620KC	C102F, AM Osc. coil Trimmer	
3	Same	1500KC	1500KC	C102B, Ant. Trimmer, C102D, AM Mixer coil Trimmer	
4	Same	600KC	600KC	T102, AM Mixer coil Slug	
5	Same	537KC	fully closed	T101 AM Osc. coil Slug	

C-282 and C-318

STEP	CONNECT GENERATOR	SET GENERATOR AT	SET GANG AT	ADJUST	TO OBTAIN
1.	Grid of AM Conv., 6BE6 (pin 7 of V103) Through .1 mfd.	455KC	Fully Open	T102, T104 & T106 (IF Slugs)	M A O U T P U T M
2.	Ant. Section of Gang (through .1 mfd.)	1620KC	1620KC	C156, AM Osc. Trim. & C154, AM Conv. Trim	
3.	- Same -	1500KC	1500KC	C152. AM Ant. Trim.	
4.	- Same -	600KC	600KC	L103, Loop Loading Coil & L111* AM Osc. Coil	
5.	"Ant" Terminal (on rear of chassis) with Loop connected.	455KC	Quiet Point	L102, Wave Trap (on Loop Ant.)	Minimum Output

* Adjust while rocking gang condenser.

CHASSIS C-282, C-284, C-305, C-318

C-284

STEP	CONNECT GENERATOR	SET GENERATOR AT.	SET GANG AT	ADJUST	TO OBTAIN
1.	Grid of Mixer, 6SA7 (pin 5 of V102) through .1 mfd.	455KC	Fully Open	IF Slugs T102, T103 & T104	MAXIMUM OUTPUT
2.	RF Section of Gang through 1. mfd.	1620KC	1620KC	C102C Osc. Trim. (on gang)	MAXIMUM OUTPUT
3.		1500KC	1500KC	C102A, Ant. Trim. C102B, RF Trim. (on gang)	MAXIMUM OUTPUT
4.		600KC	600KC	L103, Loop Loading Coil and L104* Osc. Coil	MAXIMUM OUTPUT
5.	Terminal "A" Ant. Term. Strip (with Loop connected)	455KC	Quiet Point	L102, Wave Trap on Loop	MINIMUM OUTPUT

FM Alignment

- Connect the oscilloscope and FM or RF Generator as shown in the chart.
- Set the Operation Selector in the FM position.
- Turn the Receiver on.
- During alignment, reduce the generator output to keep the signal just above noise level to avoid overloading.
- For maximum signal transfer, Signal Generator should be balanced to 300 ohm FM Antenna terminal input.

C-282 and C-318

IF SECTION

STEP	CONNECT FM (SWEEP) GENERATOR	SET GENERATOR AT	SET GANG AT	CONNECT OSCILLOSCOPE	ADJUST	REMARKS
1	Grid 6BA6 2nd I-F Amp. pin #1, V105	10.7 MC \pm 100KC dev.	fully open	Across C138 (Grd. lead to chassis)	Top & bottom slugs of T105	Adjust for "S" curve and centered so that the two curved portions are symmetrically spaced from the center.
2	Grid of 6BA6 (1st IF amp) pin #1, V104	10.7 MC \pm 100KC dev.	open	Same	Top & bottom slugs of T103	
3	Grid of 12AT7 (FM Mixer) pin #2, V102, through 1000 uuf.	10.7 MC \pm 100KC dev.	open	Same	Top & bottom slugs of T101	

C-282 and C-318

RF SECTION

STEP	CONNECT SIGNAL GENERATOR	SET GENERATOR AT	SET GANG AT	CONNECT VTVM	ADJUST	REMARKS
1.	High Side of FM dipole thru 330 ohms	106MC	106 MC	Across R132	C155, FM Osc. Trim.	Adjust for Maximum
2.	-Same-	105MC	105MC	- Same -	C153, FM Mixer Trim. & C151, FM Ant. Trim.	Adjust for Maximum while rocking gang condenser

CHASSIS C-282, C-284, C-305, C-318 C-305 IF SECTION

STEP	CONNECT FM (SWEEP) GENERATOR	SET GENERATOR AT	SET GANG AT	CONNECT OSCILLOSCOPE	ADJUST	REMARKS
1	Grid 6BA6 (2nd I-F Amp) pin #1, V104	10.7 MC ± 100KC dev.	fully open	Across C130 (Grd lead to chassis)	Top & bottom slugs of T107	
2	Grid of 6BA6 (IF amp) pin #1, V103	10.7 MC ± 100KC dev.	open	Same	Top & bottom slugs of T105	
3	Contact D10 of section 2 rear of the Band Switch	10.7 MC ± 100KC dev.	open	Same	Top & bottom slugs of T103	

C-305

RF SECTION					
STEP	CONNECT RF GENERATOR	SET GENERATOR AT	SET GANG AT	ADJUST	REMARKS
1.	To FM Ant. Terminals	Modulated 106MC	106MC	*L103 osc. coil by adj. spacing of turns	For Max. Sound Output
2.	Same	Modulated 90 MC	90 MC	Plates of FM Csc. tuning capacitor	If necessary adjust the end plates of the FM Osc. Section of the gang for Max. Output.
3.	Repeat adjustment of L103 (Step 1) to calibrate dial pointer at 90 MC and 106 MC respectively, with the R-F Unit Shield in place.				
4.	To FM Ant. terminals	Modulated 106 MC	106 MC	C102D FM trimmer on Mix. Sec.	Max. output while rocking gang
5.	Same	Same	Same	C102A FM trimmer on Ant. section	Maximum Output
6.	Same	Modulated 90 MC	90MC	* L103 (mixer)	Check coils with a tuning wand. If necessary expand or compress coil turns for max. output
7.	Same	Same	Same	L102 FM Ant. Coil	

* Cement both coils on L103 after adjusting.

Check calibration of dial against known AM and FM stations.

C-295 PREAMPLIFIER CIRCUIT DIAGRAM

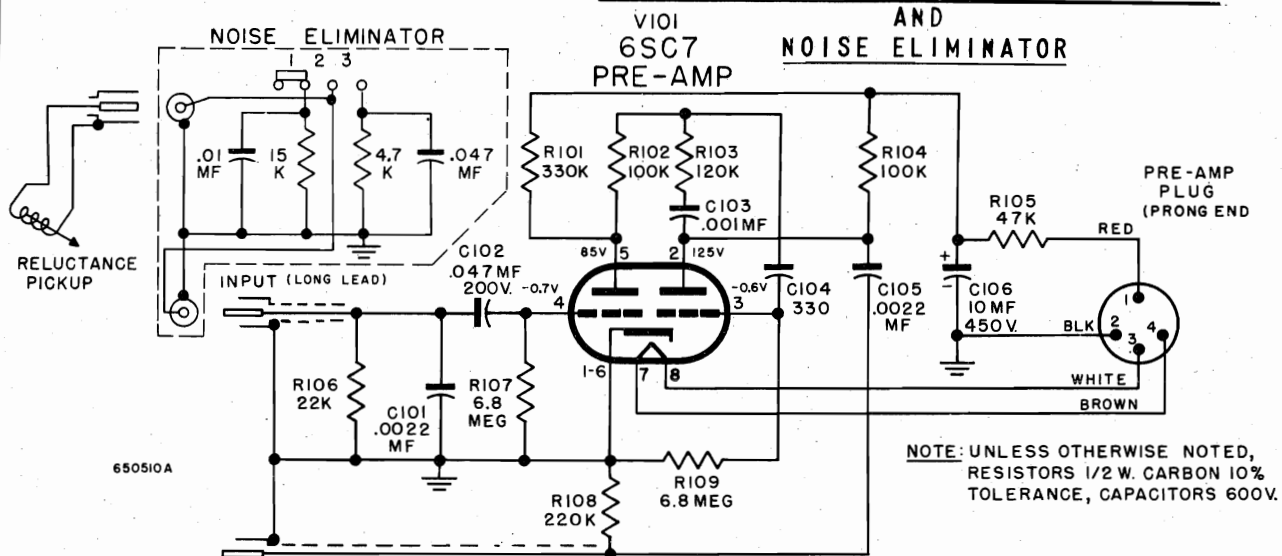

MODELS 1007AM, Ch. C-318;
1008M, 1009F, 1010B, Ch. C-282

SCHEMATIC DIAGRAM RADIO CHASSIS C-282 & C-318

ALL VOLTAGES ARE MEASURED WITH BAND SWITCH IN AM POSITION EXCEPT FOR V102 & V106 WITH BAND SWITCH IN FM POSITION. IN THE PHONO AND TV POSITIONS VOLTAGES ARE APPLIED ONLY TO V109 V110 & V111. THESE VOLTAGES ARE ENCLOSED IN A BOX [] VOLTAGE READINGS MAY VARY WITHIN 20%. MEASUREMENTS MADE WITH VOLTOHMYST OR EQUIVALENT. VOLTAGES MEASURED FROM CHASSIS GROUND.

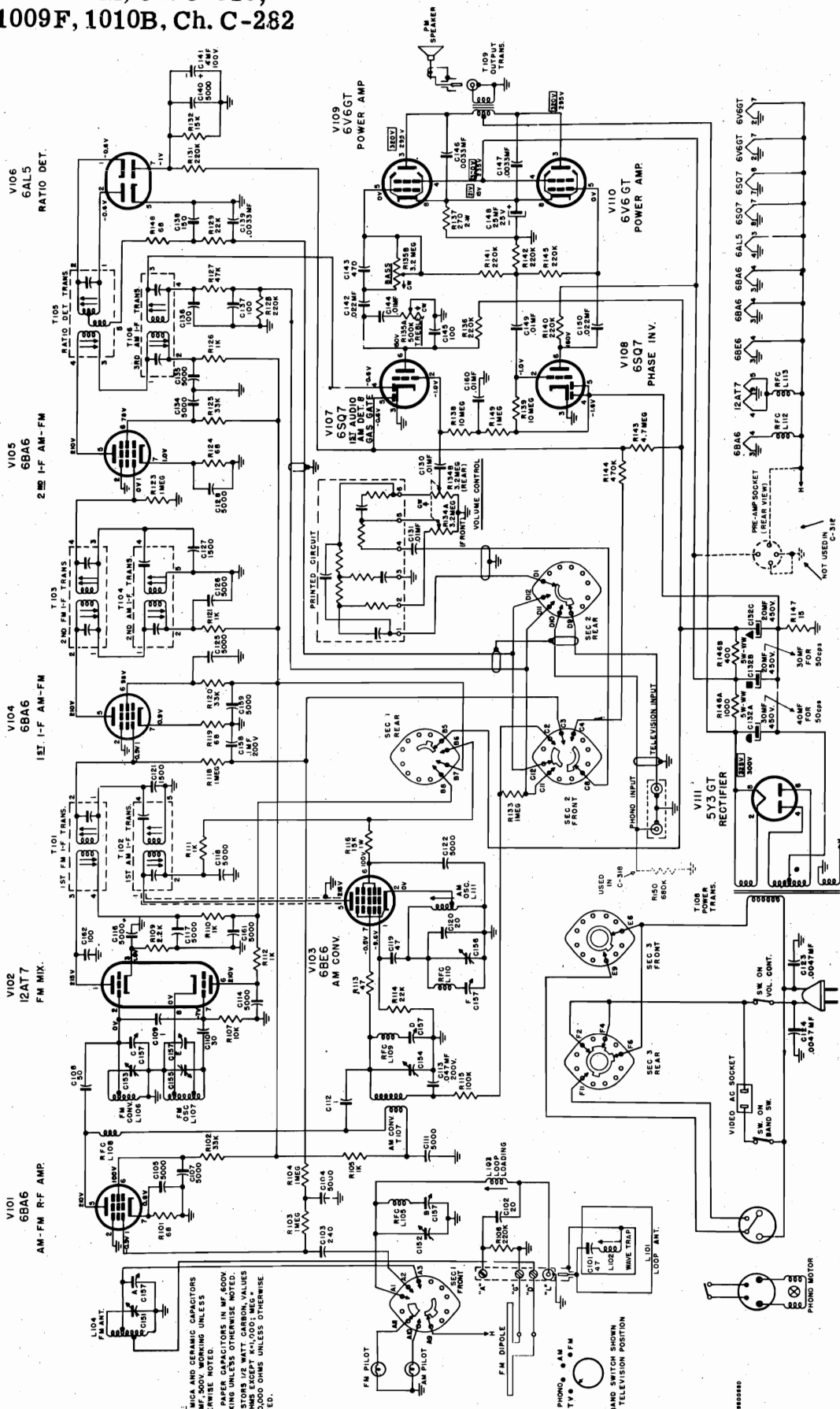

NOTE: mica and ceramic capacitors are in mf. unless otherwise noted. all paper capacitors in mf. unless otherwise noted. resistors 1/2 watt carbon values unless otherwise noted.

PHONO * AM TV * FM BAND SWITCH SHOWN IN TELEVISION POSITION

RADIO CHASSIS C-284

CHASSIS C-284

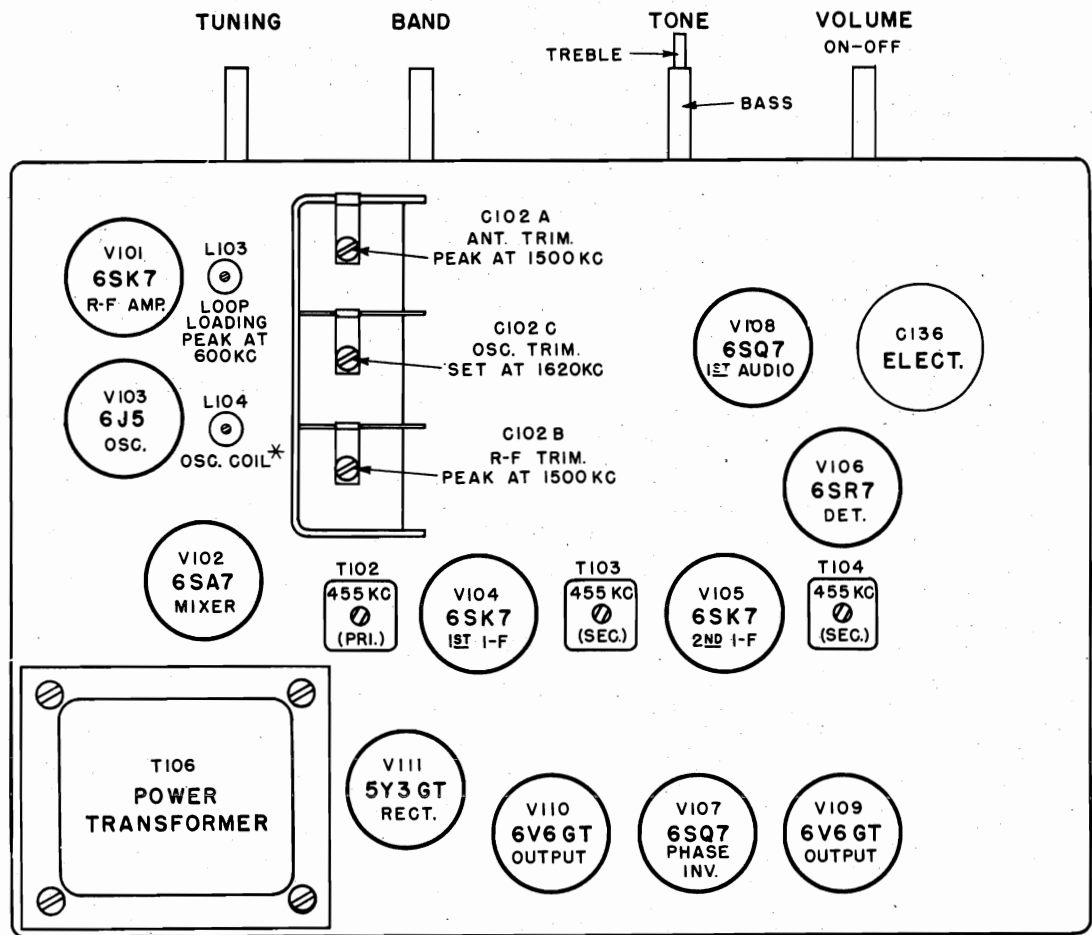

* PEAK AT 600KC WHILE ROCKING GANG CONDENSER

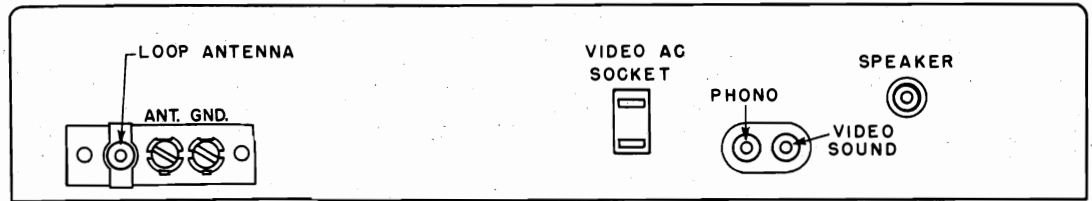

DIAL STRINGING C-284

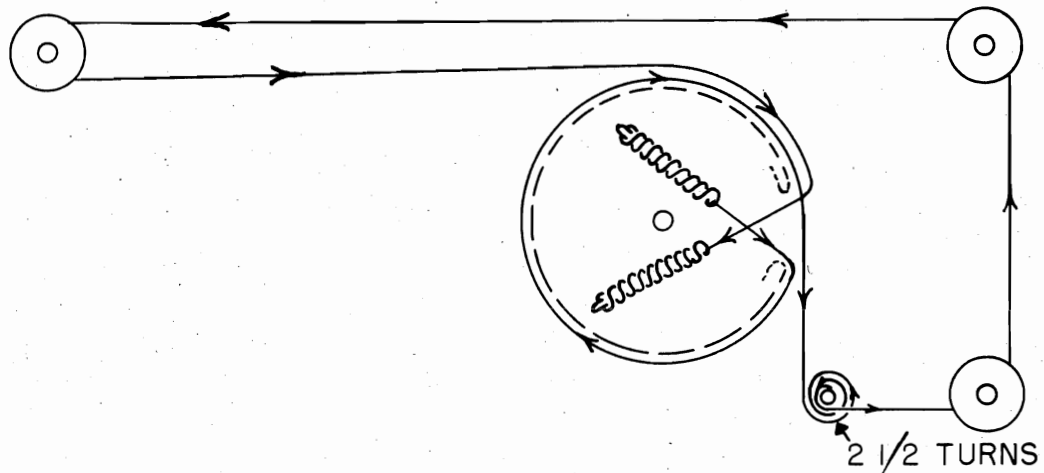

CHASSIS C-284

SCHMATIC DIAGRAM RADIO CHASSIS C-284

NOTE:
 ALL MICA AND CERAMIC CAPACITORS
 IN MF, 500V WORKING UNLESS
 OTHERWISE NOTED.
 ALL PAPER AND ELECTROLYTIC CAPACITORS
 IN MF, 500V WORKING UNLESS OTHERWISE
 NOTED.
 RESISTORS 1/2 WATT CARBON, VALUES IN
 OHMS EXCEPT K=1,000, MEG=1,000,000
 OHMS UNLESS OTHERWISE NOTED.

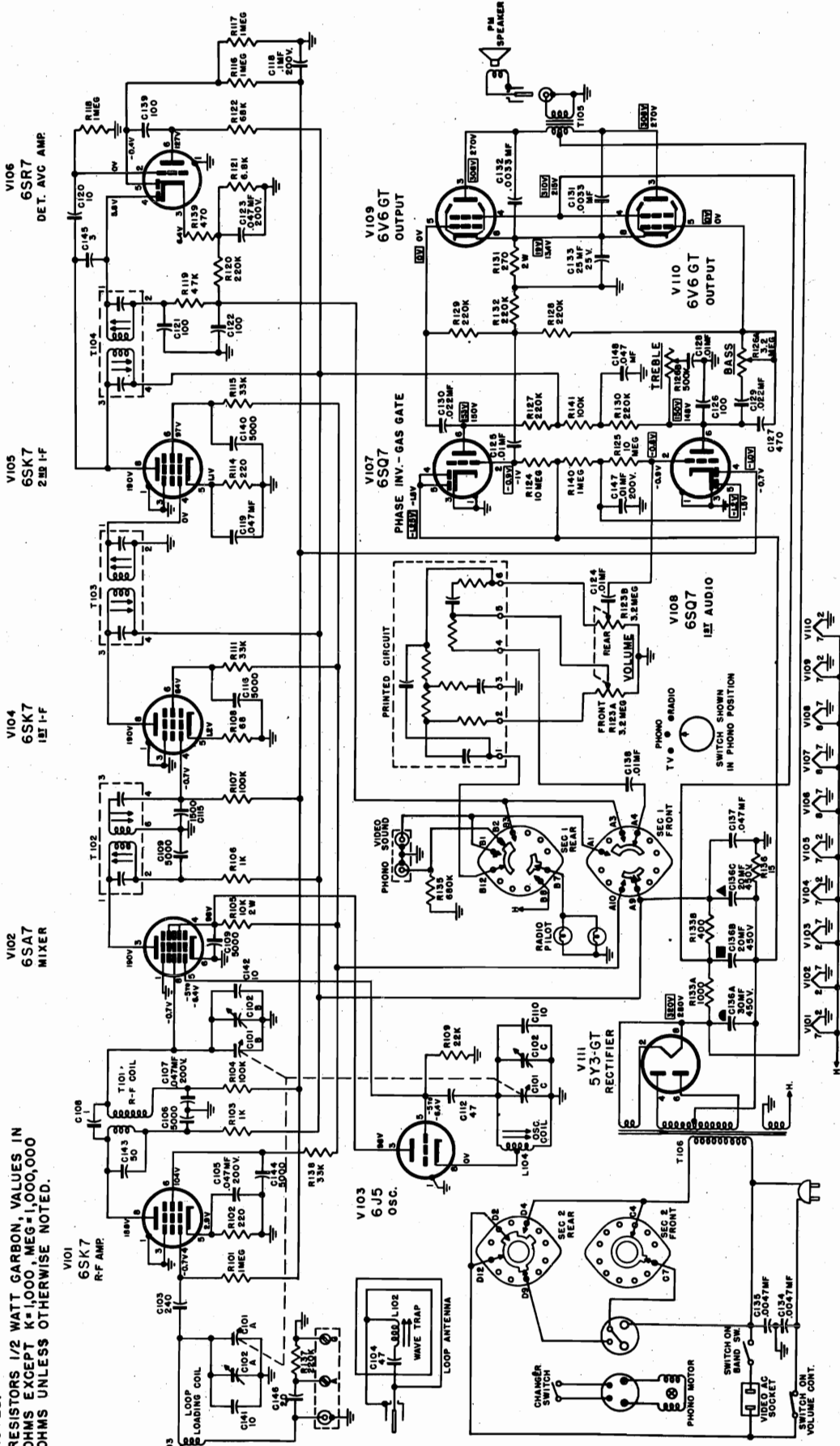

850091 B

ALL VOLTAGES MEASURED WITH BAND SWITCH IN RADIO POSITION.
 IN THE PHONO & TV POSITIONS ONLY V107, V108, V109 & V110 ARE IN OPERATION.
 THESE VOLTAGES ARE ENCLOSED IN A BOX [] V. VOLTAGE READINGS MAY VARY WITHIN 20%.
 MEASUREMENTS MADE WITH VOLTOHMIST OR EQUIV. VOLTAGES MEASURED FROM CHASSIS GROUND.

RADIO CHASSIS C-305

MODELS 1008AM,
1009AF, 1010AB,
Ch. C-305

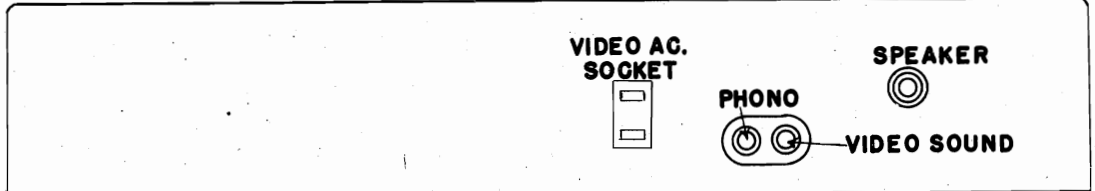
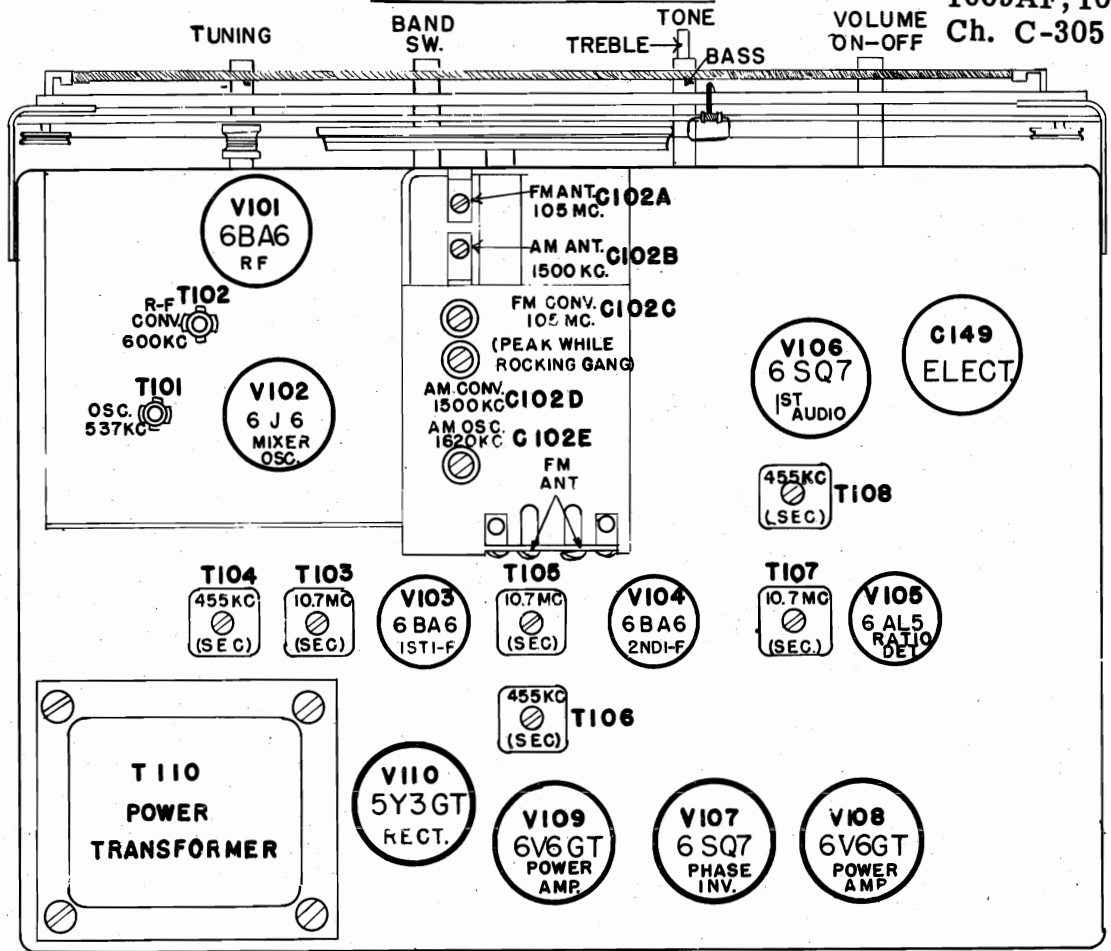

DIAL STRINGING C-305

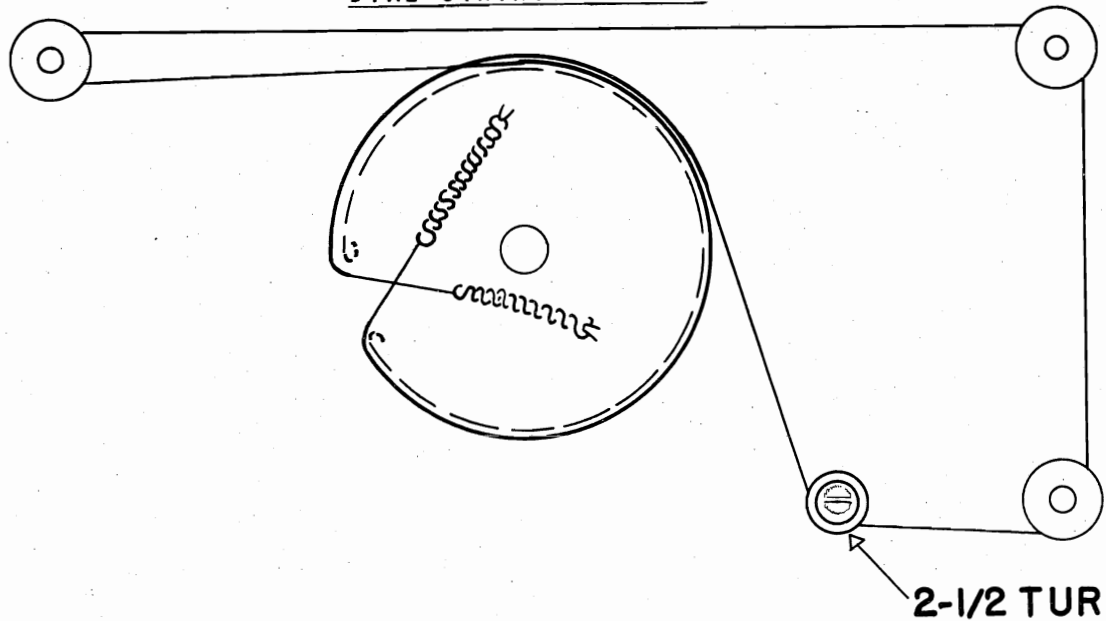

MODELS 1008AM, 1009AF,
1010AB, Ch. C-305

SCHMATIC DIAGRAM RADIO CHASSIS C-305

ALL VOLTAGES ARE MEASURED WITH BAND SWITCH IN AM POSITION.
IN THE PHONO & TV POSITIONS. VOLTAGES ARE ONLY APPLIED TO
V108, V109 & V110. THESE VOLTAGES ARE ENCLOSED IN A BOX [OV].
VOLTAGE READINGS MAY VARY WITHIN 20%.
MEASUREMENTS MADE WITH VOLTOHMIST OR EQUIVALENT.
VOLTAGES MEASURED FROM CHASSIS GROUND.

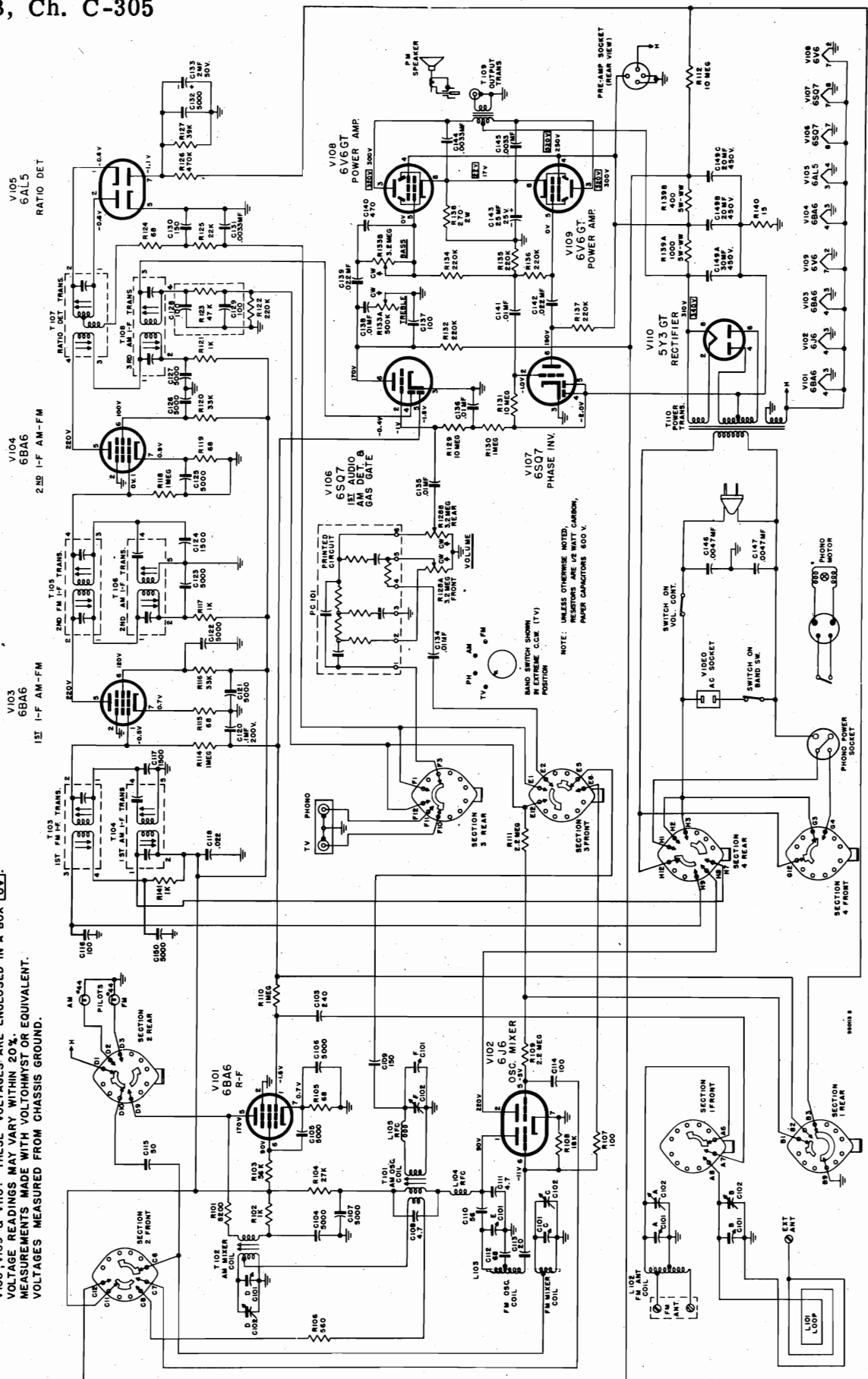

PARTS LIST RADIO CHASSIS C-282 & C-318

- CAPACITORS -

Ref. no.	Description	Part no.	List
C101, C119	Mica, 47 uuf, 10%, 500V.....	25193	\$.30
C136, C 137, C 145	Mica, 100 uuf, 10%, 500V.....	25188	.20
C138	Mica, 150 uuf, 10%, 500V.....	650162A-8	.20
C143	Mica, 470 uuf, 10%, 500V.....	25189	.25
C121, C127	Silver Mica, 1500 uuf, 5%, 500V.....	25299	.90
C102, C120	Ceramic, 20 uuf, 10%, 500V.....	25492	.20
C103	Ceramic, 240 uuf, 10%, 500V.....	25427	.20
C104, C105, C111)			
C114, C116, C107)			
C117, C118, C122)			
C125, C126, C128)			
C134, C135, C140)			
C159, C161)	----Ceramic, 5000 uuf, 10%, 500V.....	450469A-1	.25
C108	Ceramic, 50 uuf, 10%, 500V.....	25493	.20
C109, C112	Ceramic, 1 uuf, 20%, 500V.....	25497	.25
C110	Ceramic, 30 uuf, 10%, 500V.....	650030A-8	.30
C162	Ceramic, 100 uuf, 10%, 500V.....	2241A-367	.40
C113	OPT, .047 ufd, 20%, 200V.....	2246A-4530	.20
C123, C124	OPT, .0047 ufd, 20%, 600V.....	2244A-4720	.25
C130, C131, C144)			
C149, C160)	----OPT, .01 ufd, 20%, 500V.....	2248A-1030	.20
C136, C137, C147	OPT, .0033 ufd, 20%, 600V.....	2248A-3320	.20
C142, C150	OPT, .022 ufd, 20%, 600V.....	2248A-2230	.25
C158	OPT, .1 ufd, 20%, 600V.....	2246A-1040	.25
C132A	Elect, 30 ufd, 450V)		
C132B, C132C	Elect, 20 ufd, 450V)-----	25424	3.45
C141	Elect, 4 ufd, 100V.....	25270	1.05
C148	Elect, 25 ufd, 25V.....	25158	.80
C151, C153	Trimmer Strip (FM Ant. & Mixer).....	26280	.55
C152	Trimmer (AM Ant.).....	26279	.30
C154, C156	Trimmer Strip (AM Conv. & Osc.).....	450468A-2	.70
C155	Trimmer (FM Osc.).....	452094A-1	1.40
C157	Variable Gang Capacitor Ass'y.....	452051A-G1	6.75

- RESISTORS -

R101, R119, R124)			
R148)	----Carbon, 68 ohms, 1/2w, 10%.....	3229A-680	.10
R102, R 120, R125	Carbon 33K, 1/2w, 10%.....	3229A-333	.10
R103, R104, R118)			
R123, R133, R149)	----Carbon, 1 megohm, 1/2w, 10%.....	3229A-105	.10
R105, R110, R112)			
R111, R121, R126)	----Carbon, 1K, 1/2w, 10%.....	3229A-102	.10
R106, R128, R131)			
R136, R140, R141)			
R142, R145)	----Carbon, 220K, 1/2w, 10%.....	3229A-224	.10
R107	Carbon, 10K, 1/2w, 10%.....	3229A-103	.10
R109	Carbon, 2.2K, 1/2w, 10%.....	3229A-222	.10
R113	Carbon, 47 ohms, 1/2w, 10%.....	3229A-470	.10
R114 R129	Carbon, 22K, 1/2w, 10%.....	3229A-223	.10
R115	Carbon, 100K, pw, 10%.....	3229A-104	.10
R116	Carbon, 15K, 1w, 10%.....	3229A-153	.10
R127	Carbon, 47K, 1/2w, 10%.....	3229A-473	.10
R132	Carbon, 15K, 1/2w, 10%.....	3229A-153	.10
R137	Carbon, 270, 2w, 10%.....	3225A-271	.40
R138, R139	Carbon, 10 megohm, 1/2w, 10%.....	3229A-106	.10
R143	Carbon, 4.7 megohm, 1/2w, 10%.....	3229A-475	.10
R144	Carbon, 470K, 1/2w, 10%.....	3229A-474	.10
R147	Carbon, 15 ohms, 1/2w, 10%.....	3229A-150	.10
R146A	Molded Resistor, 1000 ohms, 5w)		
R146B	Molded Resistor, 400 ohms, 5w)-----	77463	.80
R134	Volume Control (dual 3.2 megohms).....	650285A-1	2.15
R135A	Treble Tone Control, 500K)		
R135B	Bass Tone Control, 3.2 megohms)-----	78159	1.80
R150	Carbon, 680K, 1/2w, 10% (C-318 only).....	3229-684	.10

CHASSIS C-282, C-318

Parts List Radio Chassis C-282 & C-318 Cont'd.

Ref. no.	Description	Part no.	List
- INDUCTANCES -			
T101	Transformer, 1st FM IF.....	650 251A-1	1.40
T102, T104	Transformer, 1st & 2nd AM IF.....	4520 19A-1	1.60
T103	Transformer, 2nd FM IF.....	45 2027A-1	1.45
T105	Transformer, Ratio Detector.....	4520 28A-1	2.00
T106	Transformer, 3rd AM IF.....	450 336A-1	1.50
T107	Transformer, AM Converter.....	38961	1.20
T108	Transformer, Power.....	750 182A-1	11.10
T109	Transformer, Output.....	650 245A-1	3.50
L101	Loop Antenna Assembly (AM).....	750 165A-1	5.35
L102	Wave Trap Coil (Part of Ass'y, 750 165A-1)		
L103	Coil Assembly, Loop Loading.....	38963	.60
L104	Coil Assembly, FM Antenna.....	38958	.55
L106	Coil Assembly, FM Mixer.....	38959	.50
L107	Coil Assembly, FM Oscillator.....	38960	.55
L111	Coil Assembly, AM Oscillator.....	4520 30A-1	.80
L105, L108, L109)			
L110, L112, L113)----	RF Choke Coil.....	38884	.20

- MISCELLANEOUS -

Description	Part no.	List
Printed Circuit.....	77462	1.60
Band Switch.....	750 158B1	4.15
Cable--Pre Amp (C-282 only).....	650 259A-1	1.10
Cord--Phono AC.....	22193	1.25
Line Cord.....	650 171A2	.60
Pointer.....	650 252A1	.20
Pointer Sleeve.....	4520 43A2	.10
Pointer Rod.....	55383	.15
Drive Cord Assembly.....	4520 41AG1	.65
Dial Glass (AM) (C-282 only).....	750 161B1	.35
Dial Glass (FM) (C-282 only).....	750 161B2	.35
Channel (Dial Glass).....	4520 42A2	.15
Hum Shield.....	05147	.10
Speaker Socket.....	80030	.10
Connector (Phono-Tel.).....	450972A1	.20
Dial Glass (AM) (C-318 only).....	750 284A-1	.36
Dial Glass (FM) (C-318 only).....	750 284A-2	.36

PARTS LIST PRE-AMPLIFIER CHASSIS C-295

- RESISTORS -

Ref. no.	Description	Part no.	List
R106	Carbon, 22K, 1/2w, 10%.....	3229A-223	.10
R105	Carbon, 47K, 1/2w, 10%.....	3229A-473	.10
R102, R104	Carbon, 100K, 1/2w, 10%.....	3229A-104	.10
R103	Carbon, 120K, 1/2w, 10%.....	3229A-124	.10
R108	Carbon, 220K, 1/2w, 10%.....	3229A-224	.10
R101	Carbon, 33K, 1/2w, 10%.....	3229A-334	.10
R107, R109	Carbon, 6, 8 megohm, 1/2w, 10%.....	3229A-685	.10

- CAPACITORS -

Ref. no.	Description	Part no.	List
C102	OPT, .047 ufd, 200V.....	2246A-4730	.20
C103	OPT, .001 ufd, 600V.....	2248A-1020	.20
C101, C105	OPT, .0022 ufd, 600V.....	2248A-2220	.20
C104	Mica, 330 uuf, 500V.....	650162A-9	.20
C106	Elect, 10 ufd, 450V.....	452203A-1	1.25

- MISCELLANEOUS -

Description	Part no.	List
Pickup Cable.....	22169	1.00
Output Cable.....	22170	.75
Power Cable....	650258A-1	.90

PARTS LIST RADIO CHASSIS C-305

- RESISTORS -

Ref. no.	Description	Part no.	List
R101	8.2K ½w, 10%	3229A-822	.10
R102, 113, 117, 121, 141	1K ½w, 10%	3229A-102	.10
R103, 116, 120	3.3K ½w, 10%	3229A-333	.10
R104	27K ½w, 10%	3229A-273	.10
R105, 115, 119, 124	68 ohms, ½w, 10%	3229A-680	.10
R106	560 ohms, ½w, 10%	3229A-561	.10
R107	100 ohms, ½w, 10%	3229A-101	.10
R108	18K ½w, 10%	3229A-183	.10
R109, R111	2.2 meg, ½w, 10%	3229A-225	.10
R110, 114, 118, 130	1 meg ½w, 10%	3229A-105	.10
R112, 129, 131	10 meg ½w, 10%	3229A-106	.10
R122, 132, 134, 135) 136, 137)	220K ½w, 10%	3229A-224	.10
R123	47K ½w, 10% (Part of Diode Filter, 452171A-1)		
R125	22K ½w, 10%	3229A-223	.10
R126	470K ½w, 10%	3229A-474	.10
R127	39K ½w, 10%	3229A-393	.10
R128 A&B	Control (Vol. & Switch).....	650285A-1	2.30
R133 A&B	Control (Tone).....	750303A-5	1.80
R138	270 ohms 2w, 10%	3235A-271	.40
R139 A&B	Molded Resistor	750288A-3	.80
R140	15 ohms ½w, 10%	3229A-150	.10
PC101	Printed Circuit	452927A-1	1.60

- CONDENSERS -

C101ABDCEF			
C102 AGCDEF	Tuning Gang & Trimmers	650278A-1	7.15
C103	240 mmf Ceramic	650501A-3	.20
C104, 105, 106, 107 118, 119, 121, 122, 123, 125, 126, 127, 132, 150	5000 mmf, Ceramic Disc	450469A-1	.25
C108	4.7 mmf Ceramic	650030A-10	1.40
C109, 130	150 mmf, Mica	650162A-8	.20
C112	68 mmf, Cer. N-330	2241A-558	.35
C111	4.7 mmf Cer. N-750	650030A-12	.25
C110	56 mmf, Cer. N-330	2241A-554	.25

CHASSIS C-282, C-305

Parts List Radio Chassis C-305 Cont'd.

Ref. no.	Description	Part no.	List
C113	20 mmf, Cer. N-750	2241A-722	.25
C114	100 mmf, Cer. N-750	2241A-766	.25
C115	50 mmf, Ceramic	650501A-24	.20
C116	100 mmf, Cer. N-150	2241A-367	.40
C117, 124	1500 mmf, Silver Mica	650514A-13	.90
C120	.1 mfd 200V OPT.....	2246A-1040	.25
C137	100 mmf, Mica	750272A-11	.20
C131, 144, 145	.0033 mmf 600V OPT	2248A-3320	.20
C133	2 mfd, 50V Elec.....	452132A-1	5.40
C134, 135, 136, 138, 141)	.01 600V OPT.....	2248A-1030	.20
C139, 142	.022 600V OPT.....	2248A-2230	.25
C140	470 mmf 10% Mica.....	750272A-12	.25
C143	25 mfd 25V Elec.....	650228A-7	.80
C146, 147	.0047 600V (Line Buffer).....	2244A-4720	.25
C148 ABC	30 20 20 mfd 450V Elec.....	750090B-30	3.45
C128, 129, R123	Diode Filter.....	452171A-1	

- TRANSFORMERS -

T101	Coil AM Oscillator.....	452174A-1	.90
T102	Coil AM Mixer.....	452466A-1	1.53
T103	1st FM IF.....	650251A-1	1.40
T104, 106	1st & 2nd AM IF.....	452091A-1	.40
T105	2nd FM IF.....	452027A-1	1.45
T107	Ratio Detector.....	452028A-1	2.00
T108	3rd AM IF.....	450336A-1	1.50
T109	Output.....	650245A-1	3.50
T110	Power.....	750182A-1	11.10
L101	Loop Antenna.....	750194A-G1	1.20
L102	Antenna Coil (FM).....	452459A-1	.10
L103	Coil Assembly (FM Mixer & Osc).....	452454A-1	.25
L104, 105	Choke (RF Heater).....	38884	.20

- MISCELLANEOUS -

	Band Switch.....	750238A-1	
	Speaker Socket.....	80030	.10
	Connector (Phono-TV).....	450972A-1	.20
	Dial Glass AM.....	750161B-1	.35
	Dial Glass FM.....	750161B-2	.35
	Channel (Dial Glass).....	452042A-2	.15
	Pointer.....	650252A-1	.20
	Line Cord.....	650171A-2	.60
	Cord (Phono AC).....	650502A-1	1.25
	Cable (Pre Amp).....	650259A-1	1.10
	Speaker.....	850105A-1	14.35
	Receptacle (2 prong).....	450427A-1	.30
	Mounting Clips.....	58514	.10

PARTS LIST RADIO CHASSIS C-284

- CAPACITORS -

Ref. no.	Description	Part no.	List
C101	Variable (3 gang) tuning Capacitor.....	452040A-G1	5.25
C102A)	Assembly		
	Antenna Trimmer)		
C102B)-----	RF Trimmer)-----Part of Assembly.#452040A-G1		
C102C)	Osc. Trimmer)		

Parts List Radio Chassis C-284 Cont'd.

Ref. no.	Description	Part no.	List
C144	Ceramic, 3.3 uuf., 20%, 500V.....	650030-5	.10
C103	Ceramic, 240 uuf., 20%, 500V.....	25427	.20
C143	Ceramic, 50 uuf., 10%, 500V.....	25493	.20
C108	Ceramic, luuf., 20%, 500V.....	25497	.25
C110)			
C141) -----	Ceramic, 10 uuf., 10%, 500V.....	25479	.30
C142)			
C146	Ceramic, 20 uuf., 10%, 500V.....	25492	.20
C106, C109)			
C113, C116) -----	Ceramic Disk, 5000 uuf., 450 V.....	450469A-1	.25
C140, C144)			
C104	Mica, 47 uuf., 10%, 500V (part of Assy, #750165A-1)		
C112	Mica, 47 uuf., 10%, 500V.....	25193	.30
C115	Silver Mica, 1500 uuf., 5%, 500V.....	25299	.90
C120	Mica, 10 uuf., 10%, 500V.....	25049	.15
C121, C122)			
C126, C139) -----	Mica, 100 uuf., 10%, 500V.....	25188	.20
C127	Mica, 470 uuf., 20%, 500V.....	25285	.25
C105, C107)			
C119, C123) -----	OPT., .047 ufd., 20%, 600V.....	2248A-4730	.25
C137, C148)			
C125, C124)			
C128, C138)	OPT., .01 ufd., 20%, 600V.....	2248A-1030	.20
C147)			
C118	OPT., .1 ufd., 20%, 200V.....	2246A-1040	.25
C129, C130) -----	OPT., .022 ufd., 20%, 600V.....	2248A-2230	.25
C131, C132) -----	OPT., .0033 ufd., 20%, 600V.....	2248A-3320	.20
C134, C135) -----	MOPT., .0047 ufd., 20%, 600V.....	2244A-4720	.25
C133	Elec., 25 ufd., 25V.....	25158	.80
C136A	Elec., 30 ufd., 350V)		
C136B, C136C) -----	Elec., 20 ufd., 350V) -----	25424	3.45
- RESISTORS -			
R101, R116)			
R117, R118) -----	Carbon, 1 meg. ½w., 10%.....	3229A-105	.10
R140)			
R102, R14	Carbon, 220 ohms, ½w. 10%.....	3229A-221	.10
R103, R106	Carbon, 1K, ½w., 10%.....	3229A-102	.10
R104, R 107)			
R141) -----	Carbon, 100K, ½w., 10%.....	3229A-104	.10
R105	Carbon 10K, 2w., 10%.....	3235A-103	.10
R108	Carbon, 68 ohms, ½w., 10%.....	3229A-680	.10
R109	Carbon, 22K, ½w., 10%.....	3229A-223	.10
R111, R115)			
R138) -----	Carbon, 33K. ½2., 10%.....	3229A-333	.10
R119	Carbon, 47K, ½w., 10%.....	3229A-473	.10
R120, R127)			
R128, R129)			
R130, R132)			
R137) -----	Carbon, 220 K. ½w., 10%.....	3229A-224	.10
R121	Carbon, 6.8K. ½w., 10%.....	3229A-682	.10
R122	Carbon, 68K, ½w., 10%.....	3229A-683	.10
R124, R125) -----	Carbon, 10 meg., ½w., 10%.....	3229A-106	.10
R131	Carbon, 270 ohms. 2w., 10%.....	3235A-271	.40
R135	Carbon, 680K. ½w., 10%.....	3229A-684	.10
R136	Carbon, 15 ohms, ½w., 10%.....	3229A-150	.10
R139	Carbon. 470 ohms, ½w., 10%.....	3229A-471	.10
R123A	Front Section, 3.2 meg. ¼w.,) Dual Volume)		
R123B	Rear Section, 3.2 meg., ¼w.,) Control & Switch) -----	650285A-1	2.15
R126A	Bass Section, 3.2 meg. ¼w.,)		

CHASSIS C-282, C-284,
C-305, C-318

Parts List Radio Chassis C-284 Cont'd.

Ref. no.	Description	Part no.	List
R126B	Treble Section, 3.2 meg. $\frac{1}{4}$ w.,) Dual Tone Controls-----	78159	1.80
R133A	1000 Ohm Section)		
R133B	400 Ohm Section)--Molded Resistor.....	77463	.80

- COILS & TRANSFORMERS -

T101	RF Coil.....	650 248A-1	1.15
T102	1st IF Transformer.....	4520 19A-1	1.60
T103, T104	2nd & 3rd IF Transformer.....	450 336A-1	1.50
T105	Audio Output Transformer.....	650 245A-1	3.50
T106	Power Transformer.....	750 182A-1	11.10
L101	Loop Antenna Assembly.....	750 165A-1	5.35
L102	Wave Trap Coil (Part of 750165A-1)		
L103	Loop Loading Coil.....	4520 20A-1	.70
L104	Oscillator Coil.....	4520 21A-1	.80

- MISCELLANEOUS -

Description	Part no.	List
Operation Selector (Band) Switch.....	750 156A-1	3.10
AC Line Cord.....	650 171A-1	.30
Phono AC Cable.....	22193	1.25
Dial Cord Assembly.....	452041A-G1	.65
Dial Pointer.....	650252A-1	.20
Dial Pointer Sleeve.....	452043A-2	.10
Dial Glass.....	650250B-1	.45
Speaker Socket.....	80030	.10
Connector (Phono-TV Sound).....	450972A-1	.20
Connector (Video AC).....	450973A-1	.10

CABINET ASSEMBLY PARTS LIST FOR
RADIO PHONO MODELS 1007AM, 1008M & AM, 1009F & AF, & 1010B & AB

Description	Part no.	Price
Glass Escutcheon (Radio) (for 1009F, AF & 1010B).....	750 186B-1	1.60
Glass Escutcheon (Radio) (for 1008M & AM).....	750 186B-3	1.60
Glass Escutcheon (Radio) (for 1007AM).....	650 305A-1	.75
Speaker (12" PM).....	850 105A-2	14.35
Loop Antenna Ass'y. (for 1007AM, 1008M, 1009F, 1010B).....	750 165A-G3	5.90
Loop Antenna Ass'y. (for 1008AM, 1009AF & 1010AB).....	750 194A-G1	1.20
Tuning Knob (for 1010B & AB).....	650207A-2	.10
Tuning Knob (for 1009AF).....	45 2681A-1	.26
Tuning Knob (for 1007AM, 1008M, & AM, 1009F).....	650207A-1	.10
Volume Knob (for 1010B & AB).....	650207A-2	.10
Volume Knob (for 1007AM, 1008M & AM, 1009F).....	650207A-1	.10
Volume Knob (for 1009AF).....	452681A-1	.26
Bandswitch Knob (for 1010B & AB).....	650206A-2	.40
Bandswitch Knob (for 1007AM, 1008M & AM, 1009F).....	650206A-1	.40
Bandswitch Knob (for 1009AF).....	45 2684A-1	.44
Bass Tone Knob (for 1010B & AB).....	59538-2	.15
Bass Tone Knob (for 1007AM, 1008M & AM, 1009F).....	59538-1	.20
Bass Tone Knob (for 1009AF).....	452682A-1	.26
Treble Tone Knob (for 1010B & AB).....	59539-2	.15
Treble Tone Knob (for 1007AM, 1008M & AM, 1009F).....	59539-1	.20
Treble Tone Knob (for 1009AF).....	452683A-1	.23
Audio Cable.....	22150	1.15
Jewel (ON-OFF Indicator) (not used in 1007AM).....	452429A-1	.25
Bracket (ON-OFF Indicator) (not used in 1007AM).....	452428A-1	.35
Socket Assembly (Indicator Light) (not used in 1007AM).....	452427A-1	.50
Noise Eliminator Assembly (not used in 1007AM).....	452101A-GL	1.40
3 position switch.....	90265	.30
Capacitor (.01, 200V, OPT).....	2246A-1030	.20
Capacitor (.047, 200V, OPT).....	2246A-4730	.20
Resistor (4.7K, $\frac{1}{2}$ w, 10%).....	3229A-153	.10
Resistor (15K, $\frac{1}{2}$ w, 10%).....	3229A-472	.10
Noise Eliminator Escutcheon (for 1010B & AB).....	452297A-4	.35
Noise Eliminator Escutcheon (for 1008M & AM, & 1009F & AF).....	452297A-2	.30
Capehart Emblem.....	452188B-1	.25

MODEL 10,
Ch. C-312

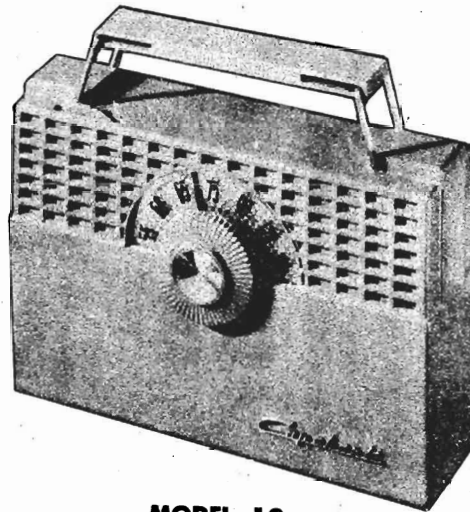

MODEL 10

SPECIFICATIONS

Tube Complement:

Type	Purpose
IR5	Oscillator-Converter
1U4	I-F Amplifier
1U5	Detector, AVC & 1st Audio Amplifier
3V4	Power Output

Loudspeaker:

Size and type Elliptical 2 x 3 inch PM
Voice coil impedance 3.2 ohms

Antenna:

Built-in "ferrite rod" antenna in rear of cabinet.

Frequency Range:

AM Broadcast Band 532 KC to 1620 KC

Cabinet Dimensions:

Height: 5 5/8 inches Width: 7 7/8 inches
Depth: 2 1/4 inches

Power Source:

Rating
0.25 Amp. at 1 1/2 VDC & 9.8 Milliamps at 67 1/2 VDC
"A" Battery 1.5 volts (Flashlight type D)
"B" Battery 67.5 volts

Weight:

Including batteries: 3 1/4 pounds

STAGE GAIN MEASUREMENTS

To facilitate troubleshooting and to determine proper operation of circuits, the following data is presented. To make these measurements, a signal generator (covering the specified frequencies) and a VTVM are required. The signal generator output should be maintained low to avoid AVC action. The listed values of gain may have tolerances of 20%.

Gain Measurements:

1R5 Conv. Grid (pin 6) to 1U4 Grid (pin 6)25 @ 1000KC
1U4 Grid (pin 6) to 1U5 Diode plate (pin 4)74 @ 455KC
1U5 Diode Plate (pin 4) to 3V4 Grid (pin 6)37 @ 455KC
3V4 Grid (pin 6) to Speaker Voice Coil19 @ 400 C.P.S.

MODEL 10,
Ch. C-312

TO REMOVE CHASSIS FROM CABINET

1. Remove the cabinet back cover and pull off the tuning knob.
2. Remove both the "A" and "B" batteries.
3. Remove the 3 chassis mounting screws (refer to the chassis layout drawing below).
4. Lift the chassis out of the cabinet from the bottom first

and pull down to clear the volume knob at the top. To operate the chassis outside the cabinet, solder two short clip leads to a flashlight cell and connect them to the "A" battery leads on the chassis (observe polarity). The "B" battery can be connected normally. Note: To prevent damage to the gang condenser, do not place the chassis face down on the service bench.

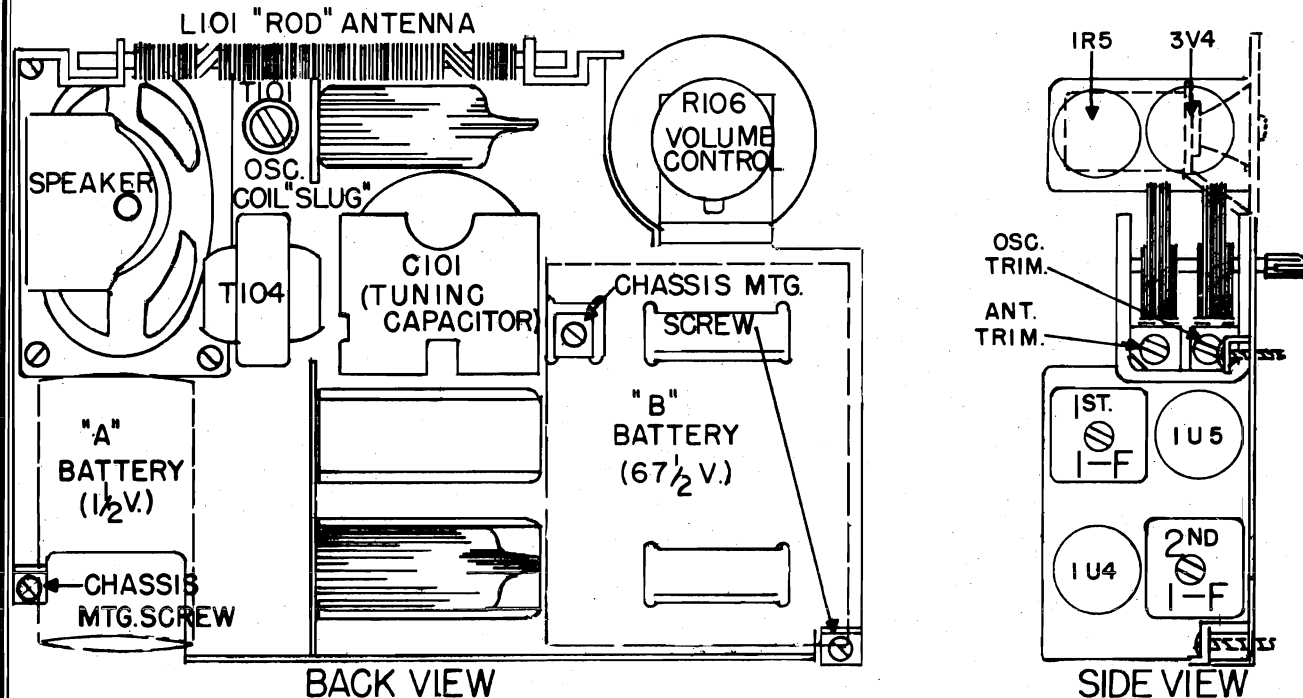

BACK VIEW

SIDE VIEW

ALIGNMENT INSTRUCTIONS

Equipment required:

1. Calibrated R.F. Signal Generator (Signal from 455KC to 1620KC).
2. Low Range Output Meter.

Alignment:

- a. Turn set on, adjust volume to maximum.
- b. See that dial pointed coincides with calibration marks at extremes of dial scale.
- c. Connect output meter across the speaker voice coil.

Step No.	Set RF Generator At	Connect RF Generator To	Set Gang Condenser To	Adjust	To Obtain
1	455KC (400 ~ Mod.)	To Grid of 1U4 (pin 6 of V102)	Fully Closed	IF Slugs T103	Max. Output
2	455KC (400 ~ Mod.)	To Grid of 1R5 (pin 6 of V101)	Fully Closed	IF Slugs T102	Max. Output
3	1620KC	To Grid of 1R5 (pin 6 of V101)	1620KC (Gang fully open)	Osc. Trimmer C101C	Max. Output
4	532KC	To Grid of 1R5 (pin 6 of V101)	532KC (Gang fully closed)	Osc. Slug T101	Max. Output
5	1500KC	See Note 1	1500KC	RF Trimmer C101A	Max. Output
6	600KC	See Note 1	600KC	Compress or spread turns on Rod Antenna (at end next to Vol. Control)	Max. Output
7	Repeat Step 5				

Note 1: Make a loop of the R-F Generator leads (Connect the leads together through a .01 mfd capacitor) and loosely couple to the Rod Antenna.

SCHEMATIC DIAGRAM CAPEHART PERSONAL PORTABLE

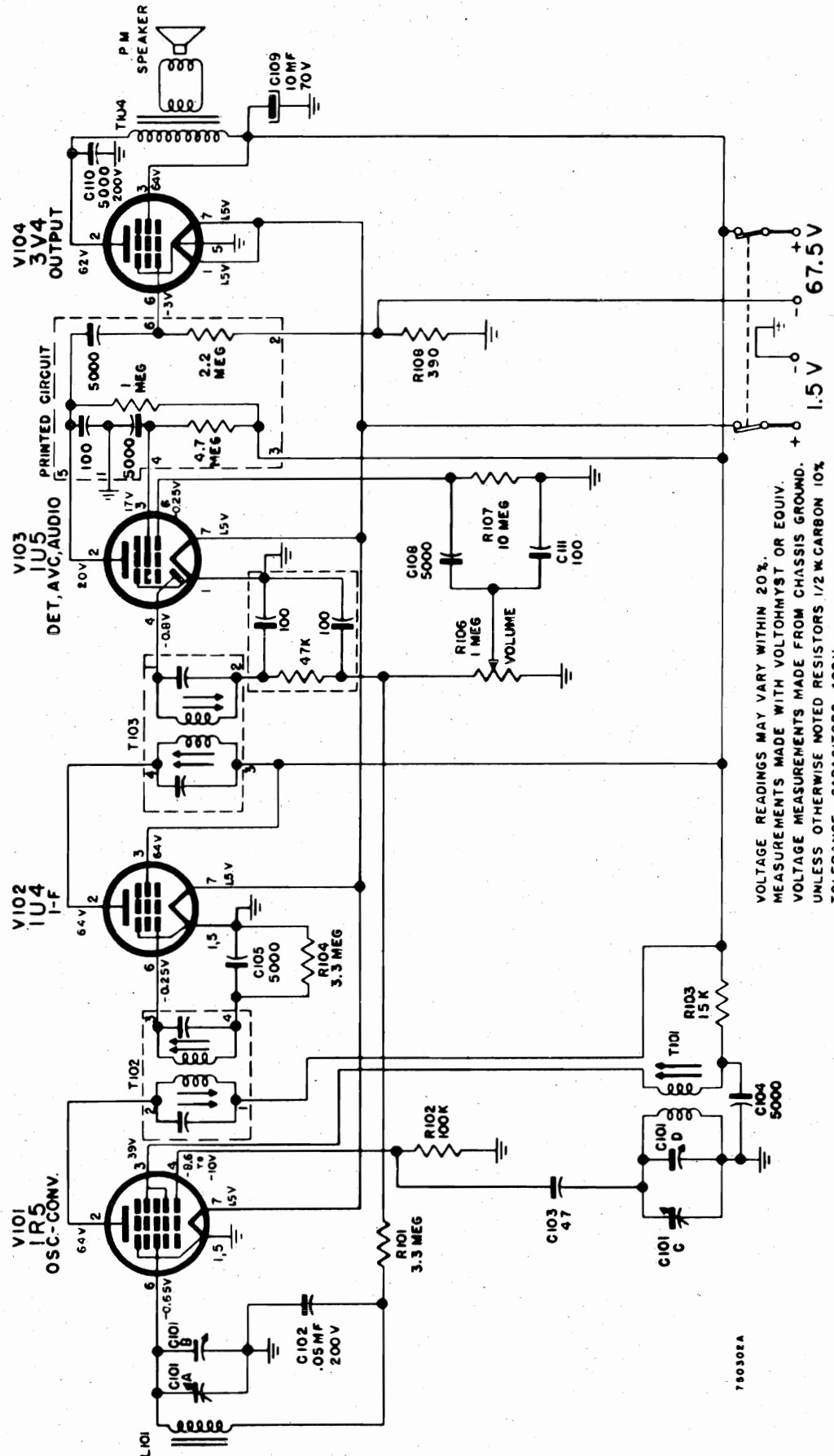

VOLTAGE READINGS MAY VARY WITHIN 20%.
MEASUREMENTS MADE WITH VOLTOHMYST OR EQUIV.
VOLTAGE MEASUREMENTS MADE FROM CHASSIS GROUND.
UNLESS OTHERWISE NOTED RESISTORS 1/2 W. CARBON 10%
TOLERANCE, CAPACITORS 400V.

780302A

MODEL 10,
Ch. C-312

BATTERY REPLACEMENT

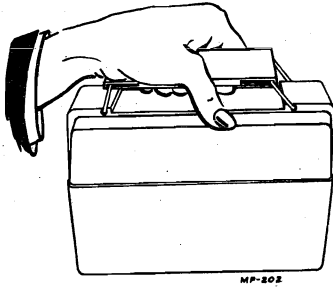

Both the "A" and "B" batteries are easily removable from the rear of the cabinet. To remove the cabinet back grasp the handle with the fingers, placing the thumb on the top of back cover (see illustration) exert thumb pressure down and away from the case. To replace the case, insert the bottom first. Exert downward pressure on back and close at top. A drawing showing proper location of the batteries is included on the inside of the back cover. When replacing batteries always try the "A" battery first. Under intermittent operating conditions, battery life is estimated at approximately 40 hours for the "B" battery and approximately 10 hours for the "A" battery. The batteries can be replaced with the following types or their equivalent: "A" battery—Eveready type 950. "B" battery—Eveready type 467. Do not allow run down batteries to remain in the cabinet. If the receiver is not to be used for a long period of time, the batteries should be removed.

— PARTS PRICE LIST —

REF. NO.	DESCRIPTIONS	PART NO.	LIST PRICE
CAPACITORS			
C1, A, B, D, & C	Tuning Capacitor	650448A-1	\$3.30
C2	.047 ufd, 200V	650450A-473	.30
C3	47 uuf, 400V Ceramic 10%	2240-006	.20
C4, 5, 8	5000 uuf, 400V Ceramic Disc	450469A-1	.25
C6, 7	Part of Diode Filter part no. 452171A-1		
C9	10 ufd, 70V Electrolytic	452132A-2	.90
C10	.0047 ufd, 200V	650450A-472	.20
C11	100 uuf, Ceramic 20%	2240-014	.20
RESISTORS			
R1, 4	3.3 meg, ½ w, 10%	3229-335	.10
R2	100K, ½ w, 10%	3229-104	.10
R3	15K, ½ w, 10%	3229-153	.10
R5	Part of Diode Filter part no. 452171A-1		
R6	Volume Control & On-Off Switch	750276A-1	1.20
R7	10 meg, ½ w, 10%	3229-106	.10
R8	390 ohm, ½ w, 10%	3229-391	.10
INDUCTANCES			
T1	Oscillator Coil	452610A-1	.80
T2, 3	I-F Transformer	750273A-1	1.55
T4	Output Transformer	452612A-1	1.90
L101	Rod Antenna	452614A-1	1.10
MISCELLANEOUS			
	*Cabinet Assembly (Green)	452815A-G4	3.70
	*Cabinet Assembly (Taupe)	452815A-G1	3.70
	*Cabinet Assembly (Burgundy)	452815A-G3	3.70
	Tuning Knob (for Taupe Cabinet)	452750A-1	.40
	Tuning Knob (for Burgundy Cabinet)	452750A-3	.40
	Tuning Knob (for Green Cabinet)	452750A-4	.40
	Volume Knob (for Green Cabinet)	452749B-2	.30
	Volume Knob (for Taupe & Burgundy Cabinets)	452749B-1	.30
	Set Screw for Volume Control	2041-122	.10
	Dial Background	452781A-1	.10
	Dial Pointer	452748A-1	.20
	Speaker	650451A-1	5.55
	Mtg. Clips for I-F Transformer	452647A-1	.10
	Diode Filter (R5, C6, C7)	452171A-1	.55
	Printed Circuit	452615A-2	.85
	"A" Battery Clip	452814A-1	.10
	Cabinet Back Cover (Taupe)	750278A-1	.95
	Cabinet Back Cover (Burgundy)	750278A-3	.95
	Cabinet Back Cover (Green)	750278A-4	.95
	Cabinet Handle (Taupe)	650491A-1	.30
	Cabinet Handle (Burgundy)	650491A-3	.30
	Cabinet Handle (Green)	650491A-4	.30
	Handle Link	452818A-1	.10

* Consists of entire front portion of cabinet complete.

MODELS TC-100,
Ch. CR-36; TC-
101, Ch. C-297

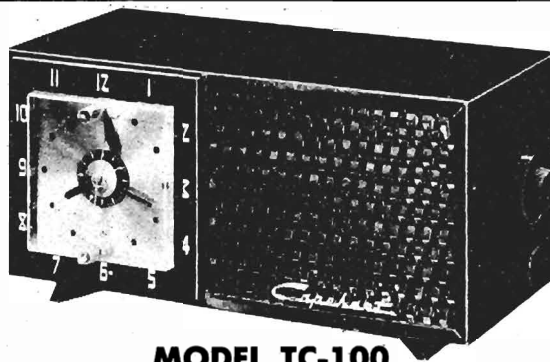

MODEL TC-100

CHASSIS DESCRIPTION

The C-297 & CR-36 are 5 tube radio chassis, designed for reception of AM (Broadcast Band) signals only. Since the chassis are operated in conjunction with an electric clock mechanism, they are to be operated only from an alternating current (AC) source. The two chassis are identical with exception that the CR-36 includes an appliance outlet.

The power source for the chassis is turned "on" and "off" by the Control Knob on the clock. When the Control Knob is in the "On" position, the radio

chassis power source is on and it is not controlled by the clock. When the Control Knob is in the "Off" position, the power source to the chassis is off and it cannot be turned on by the clock. When the Control Knob is in the "Auto" position, the power source is off, however, it will be turned on automatically by the clock mechanism at the time to which the clock alarm is set.

NOTE: The clock motor will be energized at all times when the line cord is connected to the power source.

SPECIFICATIONS

Tube Compliment:

Type	Purpose
12BE6	Oscillator-Converter
12BA6	I-F Amplifier
12AV6..	Detector, AVC & 1st Audio Amplifier
50C5	Power Outjut
35W4	Rectifier

Frequency Range:

AM Broadcast Band540KC to 1620 KC

Power Source:

Rating105-125 volts, 60 cycle AC only
Power Consumption35 watts

Appliance Outlet: (Model TC-101 only)

Maximum Rating1100 watts

Loudspeaker:

Size and type4 inch PM
Voice Coil Impedance3.2 ohms

Power Output:

.....1.5 watts

Antenna:

Built-in loop in rear of cabinet.

Cabinet Dimensions:

Height 5³/₈ inches, Width 11⁷/₈ inches,
Depth 5⁷/₈ inches.

OPERATING INSTRUCTIONS

TO SET ALARM FOR EITHER AUTOMATIC RADIO OPERATION OR "BUZZER" OR COMBINATION OF BOTH

Pull out Alarm Knob and Turn to the left; this motion will rotate the small disk in the center of the clock face. Turn the knob until the small red pointer indicates the desired time on the disk. When the Control Knob is on "AUTO", the radio will turn on automatically. Of course, the radio should be pre-tuned to a station and the Volume Control should be pre-set to the desired level to obtain proper automatic radio operation. If the

Alarm Knob is in the out position, the "buzzer" will be sounded shortly after the radio turns on.

If it is desired to have the alarm only, independent of the radio, pull the Alarm Knob out and set the Control Knob to "Off".

TO SET CLOCK

Rotate the knob on the rear of the cabinet in the clockwise direction. This will cause the clock hands to move in the normal direction. Do not cause the clock hands to move backward.

MODELS TC-100,
Ch. CR-36; TC-
101, Ch. C-297

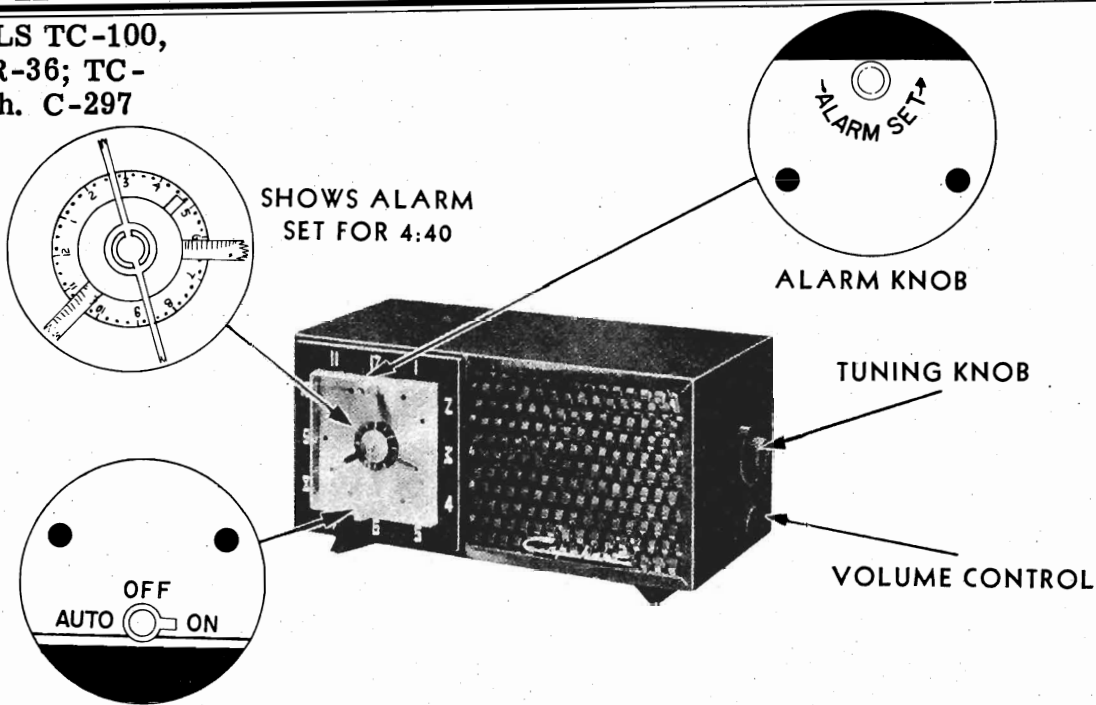

**CONTROL KNOB
TO PLAY RADIO MANUALLY**

1. Set the Control Knob to the "ON" position.
2. Adjust the Tuning Knob for the desired station.
3. Set the Volume Control so that some sound is heard from the speaker. Then re-adjust the Tuning Knob for the desired station, in the conventional manner, by setting the calibrations on the outer ring of the Tuning Knob against the small indicator located directly above it. Slight mis-adjustment of tuning will cause distortion, therefore, the

Tuning Knob should be used to adjust for the clearest sound and the Volume Control for the proper sound volume.

**TO TURN ON APPLIANCE AUTOMATICALLY
(TC-101 ONLY)**

Plug electrical appliance into outlet on rear of radio, set Control Knob at "Auto" position and the appliance will be turned on at the time determined by the setting of the Alarm Knob. The radio will operate at the same time, but if radio music is not desired the Volume Knob should be turned fully to the left.

ALIGNMENT INSTRUCTIONS

Equipment required:

1. Calibrated R.F. Signal Generator (Signal from 455KC to 1620KC).
2. Low Range Output Meter.

Alignment:

- a. Turn set on, adjust volume to maximum.
- b. Connect output meter across the speaker voice coil.
- c. Make a loop of the R-F Generator leads (connect the leads together through a .01mfd capacitor) and loosely couple to the Loop Antenna.

Step	Set RF Generator At	Set Condenser Gang At	Adjust	To Obtain
1	455KC	Tune To Quiet Point	IF Slugs T103 T102	Max. Output
2	1620KC	Fully Open	Osc. Trimmer C103D	Same
3	1500	1500	RF Trimmer C103B	Same
4	600KC	600KC	*T101 Osc. Slug	Same

* Adjust as Tuning Gang is Rocked

MODELS TC-100, Ch. CR-36; TC-101, Ch. C-297

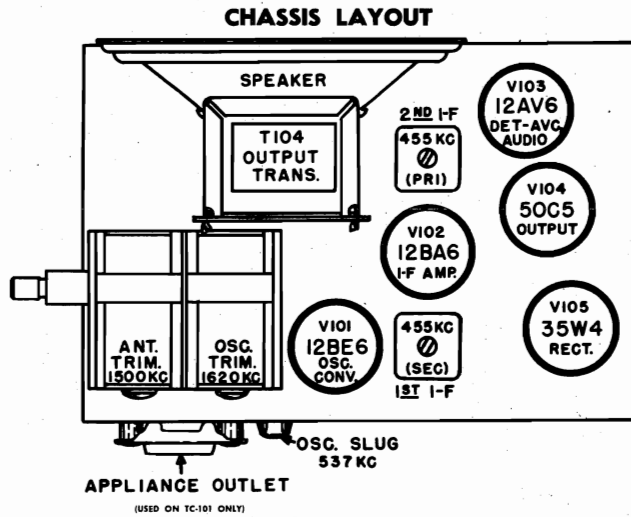

REMOVAL AND SERVICE OF CLOCK MECHANISM

SERVICE

When it is determined that the clock requires adjustment or repair, remove the clock mechanism from the cabinet (as per the following instructions) and return the clock mechanism to your Capehart distributor or an agency specified by him. If the clock mechanism is to be shipped by mail or express, be certain that it is adequately protected and properly packed.

TO REMOVE CLOCK

1. Remove the back of the cabinet by pulling off.

Note the loop antenna is fastened to the cabinet back and care should be exercised not to break off the leads.

2. Remove the two hex nuts which fasten the clock to the metal cover. Keep the metal cover and hardware (2 hex nuts, and 2 fibre washers) with the cabinet, do not return this material with the clock.
3. Pull clock out from the front of the cabinet.
4. Unsolder four (4) electrical leads from the clock. (See sketch below).
5. Remove clock.

NOTE: To re-install the clock follow the above procedure in reverse.

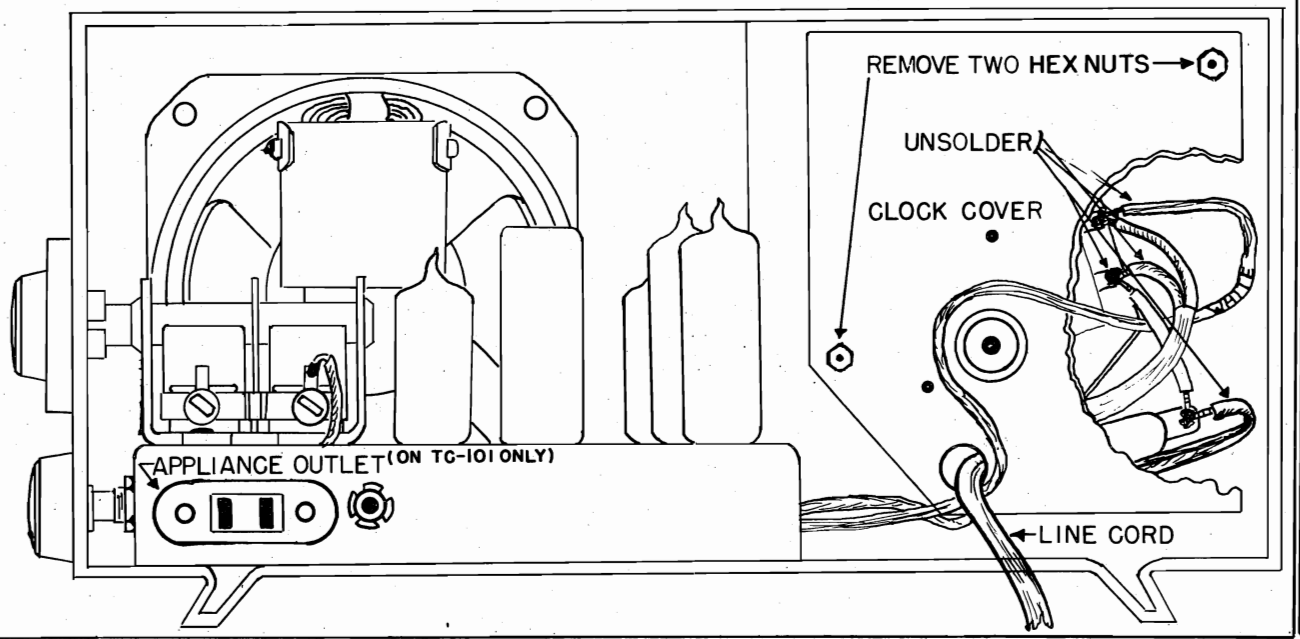

MODELS TC-100, Ch. CR-36;
 TC-101,
 Ch. C-297

SCHEMATIC DIAGRAM

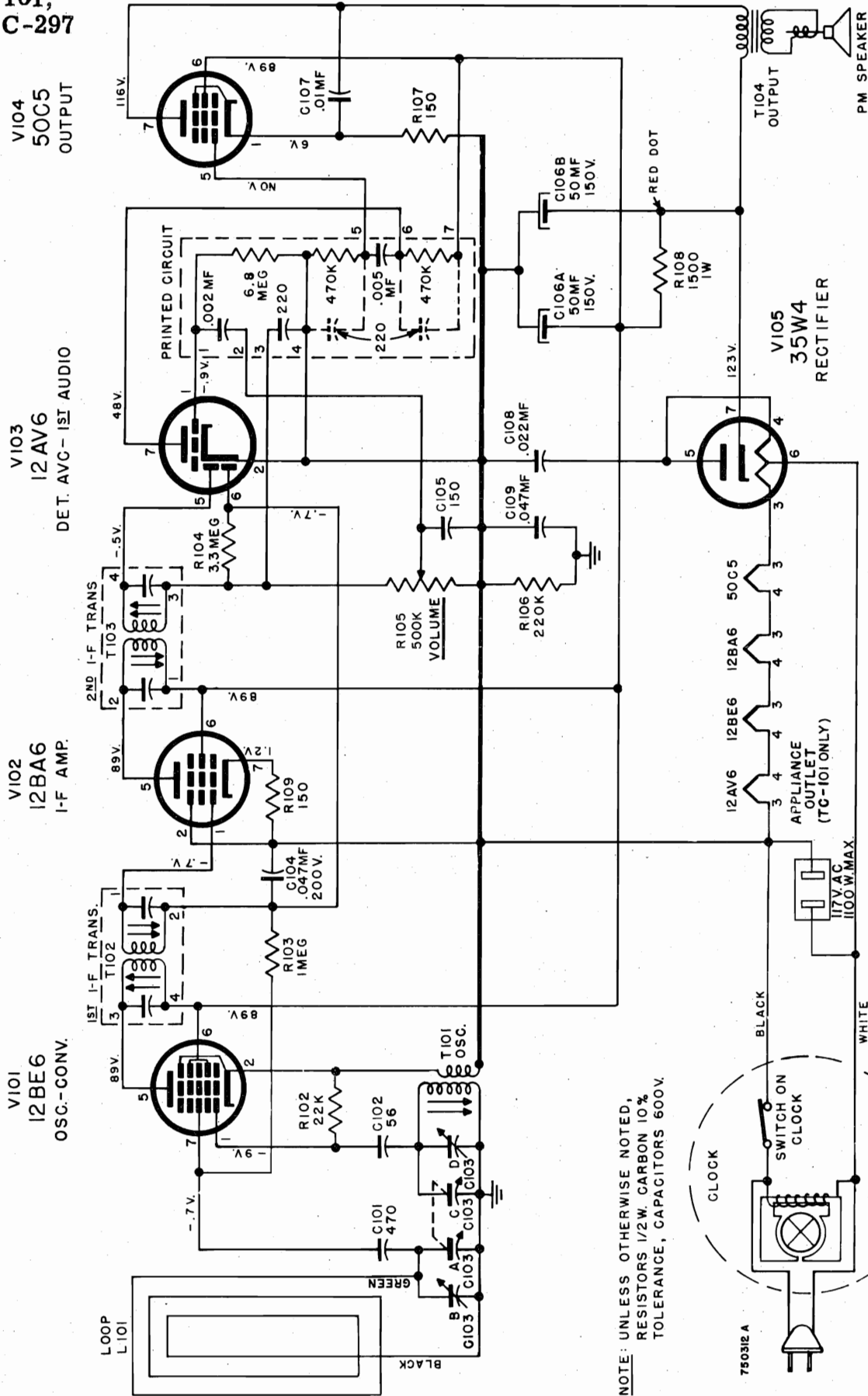

NOTE: UNLESS OTHERWISE NOTED,
 RESISTORS 1/2W. CARBON 10%
 TOLERANCE, CAPACITORS 600V.

VOLTAGE READINGS VARY WITHIN 20%
 MEASUREMENTS MADE WITH VOLTOHMYST OR EQUIV.
 VOLTAGES MEASURED FROM B-

MODELS TC-100,
Ch. CR-36; TC-
101, Ch. C-297

Ref. No.	DESCRIPTION	Part No.	List
INDUCTANCES			
L101	Loop Antenna	750207A-1	\$1.00
T101	Oscillator Coil	452242A-1	.75
T102	1st IF Transformer	452243A-1	1.40
T103	2nd IF Transformer	452243A-1	1.40
T104	Output Transformer (Part of Assy. No. 750204A-1)		
RESISTORS			
R102	22K, 1/2W, 10%	3229-223	.10
R103	1 Meg., 1/2W, 10%	3229-105	.10
R104	3.3 Meg., 1/2W, 10%	3229-335	.05
R105	500K Volume Control	452241A-1	.80
R106	220K, 1/2W, 10%	3229-224	.10
R107 & R109	150 Ohm, 1/2W, 10%	3229-151	.10
R108	1500 Ohm, 1W, 10%	3232-152	.10
	Printed Circuit	452244A-1	.90
CAPACITORS			
C103A,B,C,D	Variable Tuning Capacitor	650327A-1	2.85
C101	470 mmf. 20% Ceramic	2239-013	.20
C102	56 mmf. 10% Ceramic	2241-554	.25
C104	.047 mf. 200V (MOPT)	2246A-4730	.20
C105	150 mmf. 20% Ceramic	2240-021	.20
C106	(a. 50 mf. 150V Electrolytic) (b. 50 mf. 150V Electrolytic)	650326A-1	2.10
C107	.01 mf. 600V Paper	2248-1030	.20
C108	.022 mf. 600V (MOPT)	2244-2230	.30
C109	.047 mf. 600V (MOPT)	2244-4730	.35
MISCELLANEOUS			
	PM Speaker and Output Trans. Assy.	750204B-1	5.90
	Clock Mechanism	750311A-1	1.65
	Line Cord (TC-100)	650171A-4	.60
	Line Cord (TC-101)	650171A-3	.60
	Capehart Insignia	452188B-1	.25
	Clock Knob	452233A-2	.10
	TC-100 Cabinet Assy. (Brown)	850206A-1	4.85
	TC-100 Cabinet Assy. (Ivory)	850206A-4	4.85
	TC-101 Cabinet Assy. (Grey Blue)	850206A-6	4.85
	TC-100 Dial Knob (Brown)	650325A-8	.35
	TC-100 Dial Knob (Ivory)	650325A-10	.35
	TC-101 Dial Knob (Grey Blue)	650325A-1	.30
	TC-100 Radio Knob (Brown)	452240A-8	.15
	TC-100 Radio Knob (Ivory)	452240A-10	.15
	TC-101 Radio Knob (Grey Blue)	452240A-1	.10
	Loop Antenna (TC-100)	750310A-1	1.10
	Loop Antenna (TC-101)	750310A-2	1.10
	Appliance Outlet 117V AC 1100 Watts Max. (TC-101)	450427A-1	.30

MODEL 15,
Ch. CR-48



GENERAL DESCRIPTION

The Capehart Portable Radio, Model 15, consists of a five tube superheterodyne chassis housed in a molded polystyrene case. The radio can be operated from self-contained batteries or from 117 volts A.C. or D.C. Reception is obtained on the standard broadcast band of 537 Kc. to 1620 Kc. Three normal operating controls are available for use: On-Off Volume Control, Tone Control and Station Tuning. A three gang vari-

able tuning capacitor is used in conjunction with seven tuned circuits to provide the high selectivity and image rejection needed in a portable type radio. To aid in providing this selectivity a "ferrite rod" type built-in antenna is used. In addition to being small in size and providing excellent signal pickup, this antenna eliminates the pickup of electrostatic type interference.

Warning! Do Not Remove Any Circuit Tubes While Instrument Is Turned On

**MODEL 15
SPECIFICATIONS**

Tube Complement:

Type	
1T4	R.F. Amplifier
1R5	Osc.-Convertor
1U4	I.F. Amplifier
1U5	Det AVC Audio
3V4	Power Output

Loudspeaker:

Size & Type	4 inch PM
V. C. Impedance	3.2 ohms

Antenna:

Built-in "Ferrite Rod"

Cabinet Specifications:

Height 7½ in.	Width 10½ in.
Depth 4½ in.	Weight (tot) 7½ lbs.

Frequency Range:

AM Bdst. Band 537 Kc-1620 Kc

Power Source:

AC/DC Operation	12 watts at 105-125V DC or 60 cycle A.C.
Battery Operation	50 MA at 9 V DC & 11 MA at 90 V
Battery Type	Eveready No. 756 or equivalent

TO REMOVE CHASSIS FROM CABINET

1. Remove cabinet back cover by lifting the handle up and pulling outward at the top rear of the cabinet. After the top is disengaged the back is completely removed by disengaging the hinges at the bottom.
2. Remove two screws that hold chassis to cabinet (see chassis layout drawing).
3. With the cabinet front setting upright, the chassis can be removed by grasping the handle and sliding the chassis out the back.
4. The battery can be removed or left on the chassis as desired. Care must be exercised that the battery does not slide from the battery carrier when the chassis is being removed. Damage to the battery cable can result.

MODEL 15,
Ch. CR-48

SCHMATIC DIAGRAM

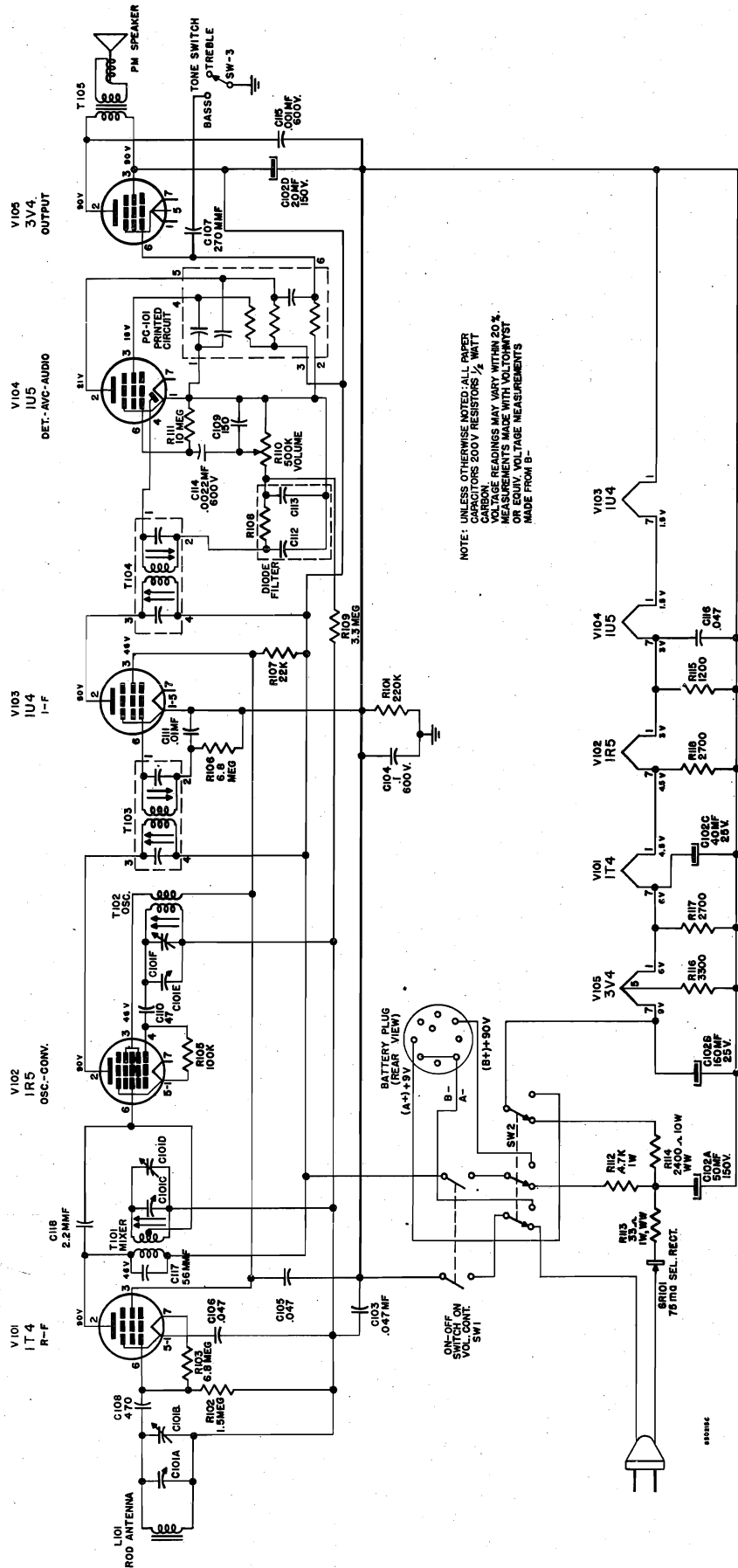

NOTE: UNLESS OTHERWISE NOTED: ALL PAPER CARBON RESISTORS 200 V RESISTORS 1/2 WATT CAPACITORS 50% TOLERANCE MEASUREMENTS MADE WITH VOLTCOMYST OR EQUIV. VOLTAGE MEASUREMENTS MADE FROM B-

MODEL 15,
Ch. CR-48

PARTS - PRICE LIST

CAPACITORS

<u>Ref. No.</u>	<u>Description</u>	<u>Part No.</u>	<u>List Price</u>
C101A-B-C-D-E-F	Tuning Capacitor	650549A-1	\$ 3.20
C102A-B-C-D	Filter Capacitor	750090B-31	3.40
C103 C105			
C106 C116	.047mfd. 200V.	2246A-4730	.20
C104	.1mfd. 600V.	2244A-1040	.55
C107	270mmf. Ceramic	650501A-18	.20
C108	470mmf. Ceramic	2239A-013	.20
C109	150mmf. Ceramic	2240A-021	.20
C110	47mmf. Ceramic	2240A-006	.20
C111	.01mfd. 200V.	2246A-1030	.20
C114	.0022mfd. 600V.	2248A-2220	.20
C115	.001mfd. 600V.	2248A-1020	.20
C117	56mmf. Ceramic	2241A-754	.25
C118	2.2mmf. Ceramic	650030A-3	.10

RESISTORS

R101	220K 1/2W 20%	3230A-224	.10
R102	1.5 Meg. 1/2W 10%	3229A-155	.10
R103 106	6.8 Meg. 1/2W 10%	3229A-685	.10
R105	100K 1/2W 20%	3230A-104	.10
R107	22K 1/2W 10%	3229A-223	.10
R109	3.3 Meg. 1/2W 20%	3230A-335	.10
R110	Volume Control & Sw.	750276A-2	1.30
R111	10 Meg. 1/2W 20%	3230A-106	.10
R112	4.7K 1W 10%	3232A-472	.15
R113	33 1W 10% WW	650101A-19	.20
R114	2.4K 10W WW	750288A-4	.85
R115	1.2K 1/2W 10%	3229A-122	.10
R116	3.3K 1/2W 10%	3229A-332	.10
R117 118	2.7K 1/2W 10%	3229A-272	.10

INDUCTANCES

L101	Loop Antenna	650547A-1	1.45
T101	Mixer Coil	453074B-1	1.25
T102	Osc. Coil	452629B-1	.85
T103 104	I. F. Transformer	750273A-1	1.55
T105	Output Transformer	453028A-1	1.95

MISCELLANEOUS

SW2	Switch (AC-DC Bat.)	452625A-1	.90
SW3	Switch (Tone Control)	453029A-1	.80
SR101	Rectifier (Selenium)	650150D-5	1.60
	Speaker	650546A-1	4.20
PC101	Printed Circuit	452615A-1	.85
	Diode Filter	452171A-1	.55
	Battery Cable	650548A-1	.65

CABINET

	Cabinet, front (Taupe)	453037A-G1	2.90
	Cabinet, front (Burgundy)	453037A-G2	2.90
	Cabinet, back (Taupe)	453038A-G1	2.40
	Cabinet, back (Burgundy)	453038A-G2	2.40
	Grille Cloth & Baffle	650541A-1	1.60
	Carrying Handle	650599A-1	.60
	Knob (tuning)	750326A-1	.90
	Knob (volume)	452749C-3	.30
	Knob (tone)	452749C-4	.30

MODEL T-30,
Ch. C-300



CHASSIS DESCRIPTION

The C-300 chassis used in the Model T-30 is a five tube radio chassis designed for reception of AM (Broadcast band) signals. The chassis contains a single ended 50L6 Power Output amplifier in conjunction with a 5" speaker for sound reproduction. It can be operated on either AC or DC.

SPECIFICATIONS

TUBE COMPLIMENT:

Type:
 12BE6 Oscillator-Converter
 12BA6 IF Amplifier
 12SQ7 Detector, AVC & 1st Aud. Amp.
 50L6 Power Output
 35Z5 Rectifier

FREQUENCY RANGE:

AM Broadcast Band 540KC to 1620KC

POWER SOURCE

Rating 105-125 volts, AC-DC
 Power Consumption 35 watts

ALIGNMENT INSTRUCTIONS

EQUIPMENT REQUIRED:

1. Calibrated RF Signal Generator (Signal from 455KC to 1620 KC).
2. Low Range Output Meter.

ALIGNMENT:

- a. Turn set on, adjust volume to maximum.
- b. See that dial pointer coincides with calibration marks at extremes of dial scale.
- c. Connect output meter across the speaker voice coil.
- d. Make a loop of the RF Generator leads (connect the leads together through a .01 mfd capacitor) and loosely couple to the Loop Antenna.

LOUDSPEAKER:

Size & Type 5 inch PM
 Voice Coil Impedance 3.2 ohms

POWER OUTPUT: 1.75 watts

ANTENNA:

Built-in Loop in rear of cabinet (Terminal on rear of cabinet for connection of outdoor aerial.)

CABINET DIMENSIONS:

Height 6 $\frac{5}{8}$ " , Width 12 $\frac{1}{2}$ " , Depth 5 $\frac{7}{16}$ " .

CHASSIS LAYOUT

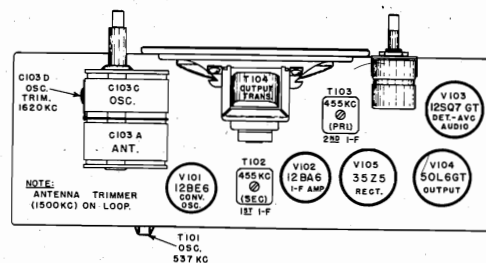

STEP	SET RF GENERATOR AT	SET CONDENSER GANG AT	ADJUST	TO OBTAIN
1	455KC	Fully Open at some quiet point	IF Slugs T103 T102	Maximum Output
2	1620KC	1620KC	Osc. Trimmer C103D	Same
3	1500	1500	Ant. Trimmer C103B (on loop)	Same
4	537KC	537KC	T101 Osc. Slug	Same

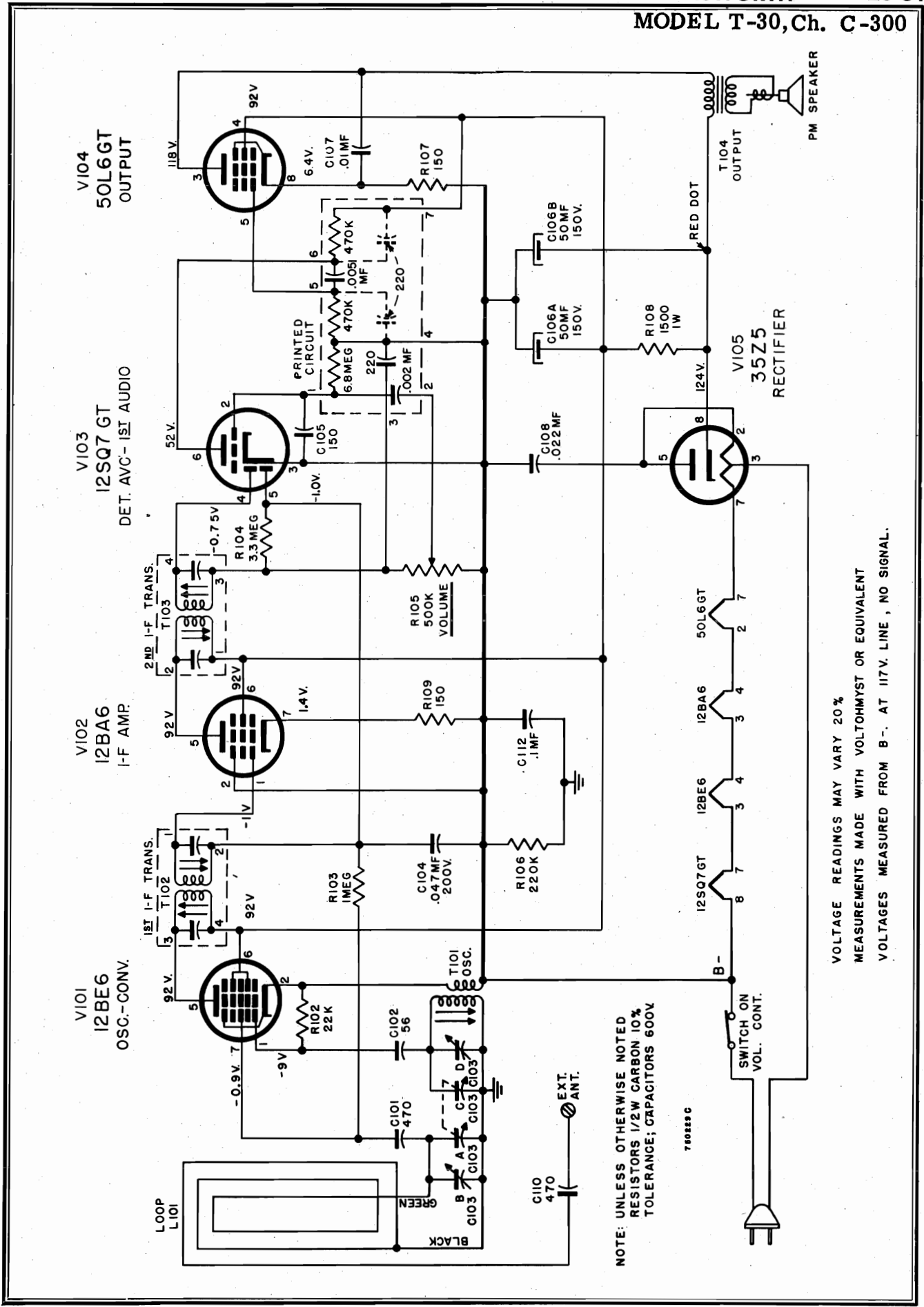

NOTE: UNLESS OTHERWISE NOTED
RESISTORS 1/2W CARBON 10%
TOLERANCE; CAPACITORS 600V

VOLTAGE READINGS MAY VARY 20%
MEASUREMENTS MADE WITH VOLTOHMYST OR EQUIVALENT
VOLTAGES MEASURED FROM B-. AT 117V. LINE, NO SIGNAL.

MODEL T-30,
Ch. C-300**PARTS LIST C-300 (T-30)**

REF. NO.	PART DESCRIPTION	PART NO.	LIST
TRANSFORMERS			
L101	Loop Antenna	750219A-1	\$1.60
T101	Oscillator Coil	452242A-1	.75
T102	IF Transformer	452243A-1	1.40
T103	IF Transformer	452243A-1	1.40
T104	Output Transformer—(Part of 750220A-1)		
RESISTORS			
R102	22K, 1/2w, 10%	3229A-223	.10
R103	1 meg, 1/2w, 10%	3229A-105	.10
R104	3.3 meg, 1/2w, 10%	3229A-335	.05
R105	Control (Volume & Switch)	452312A-1	.80
R106	220K, 1/2w, 10%	3229A-224	.10
R107, R109	150 ohms, 1/2w, 10%	3229A-151	.10
R108	1500 ohms, 1w, 10%	3232A-152	.10
	Printed Circuit	452244A-1	.90
CONDENSERS			
C101, C110	470 mmf., 20%, Ceramic	2239A-013	.20
C102	56 mmf., 10%, Ceramic	2241A-554	.25
C103, A B C D	Tuning Gang	650349A-1	3.10
C104	.047 mfd., 200V, MOPT	2246A-4730	.35
C105	150 mmf., 20%, Ceramic	2240A-021	.20
C106, A B	Electrolytic		
	(a) 50 mfd 150V	650326A-1	1.90
	(b) 50 mfd 150V		
C107	.01 mfd., 600V, MOPT	2248A-1030	.20
C108	.022 mfd., 600V, MOPT	2244A-2230	.30
C112	.1 mfd., 600V, MOPT	2244A-1040	.55
MISCELLANEOUS			
	Cabinet Ass'y (Green)	452554A-G1	5.75
	Knobs (2) (Green)	452321A-G1	.35
	Cabinet Ass'y (Burgundy)	452554A-G2	5.75
	Knobs (2) (Burgundy)	452321A-G2	.35
	Cabinet Ass'y (Ivory)	452554A-G3	5.75
	Knobs (2) (Ivory)	452321A-G3	.35
	Cabinet Ass'y (Black)	452554A-G4	5.75
	Knobs (2) (Black)	452321A-G4	.35
	Back Cover	850135A-1	.35
	Speaker, PM 5" & Output Transformer	750220A-1	8.00
	Line Cord	650171A-4	.60
	Mounting Clips for IF Transformers	58514	.10

MODEL TC-62,
Ch. CR-71

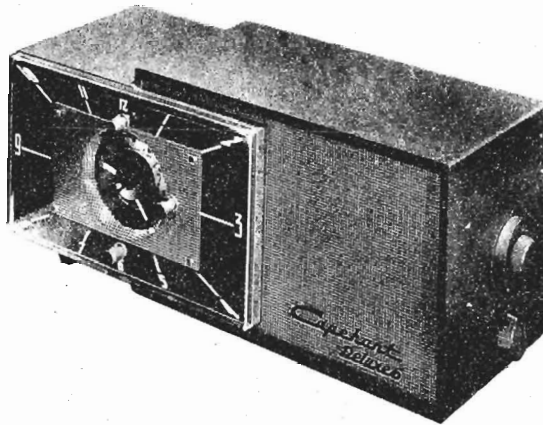

CHASSIS DESCRIPTION

The CR-71 is a 6 tube radio chassis, designed for reception of AM (Broadcast Band) signals only. Since the chassis is operated in conjunction with an electric clock mechanism, it is to be operated only from an alternating current (AC) source.

The power source for the chassis is turned "on" and "off" by the Control Knob on the clock. When the Control Knob is in the **Manual** position, the radio chassis power source is on and it cannot be turned on or off automatically by the clock. When the Control Knob is in the **Off** position, the power source to the chassis is off and it cannot be turned on by the clock. However, with the Control in the **Off** position the power source can be turned on by

adjusting the Sleep Knob for a time period up to 60 minutes and at the expiration of this time period, the power source will be turned off. (The Sleep control is a mechanical timing device which mechanically actuates the "on-off" switch which is also manually actuated by the Control Knob). When the Control Knob is in the **Wake-Up** position, the power source is off, however, it will be turned on automatically by the clock mechanism at the time to which the clock alarm is set. The function of the Sleep Knob is the same in this Control Knob position as it is in the **Off** position.

NOTE: The clock motor will be energized at all times when the line cord is connected to the power source.

SPECIFICATIONS

Tube Compliment:

Type	Purpose
12BA6	R-F Amplifier
12BE6	Oscillator-Converter
12BA6	I-F Amplifier
12AV6	Detector, AVC & 1st Audio Amplifier
35C5	Power Output
35W4	Rectifier

Frequency Range:

AM Broadcast Band540KC to 1620 KC

Power Source:

Rating105-125 volts, 60 cycle AC only
Power Consumption35 watts

Appliance Outlet:

Maximum Rating1100 watts

Loudspeaker:

Size and type4 inch PM
Voice Coil Impedance3.2 ohms

Power Output:

.....1.5 watts

Antenna:

Built-in loop in rear of cabinet
(terminal on rear of cabinet for connection of outdoor aerial.)

Cabinet Dimensions:

Height $5\frac{1}{8}$ inches, Width $12\frac{3}{8}$ inches,
Depth $5\frac{1}{2}$ inches.

MODEL TC-62,
Ch. CR-71

OPERATING INSTRUCTIONS

TO SET ALARM FOR EITHER AUTOMATIC RADIO OPERATION OR "BUZZER" OR COMBINATION OF BOTH

Pull out Alarm Knob and turn to the left, this motion will rotate the small disk in the center of the clock face. Set the pointer attached to the hour hand to the desired time indicated on the disk. When the Control Knob is on **Wake-Up** the radio will turn on automatically. Of course, the radio should be pre-tuned to a station and the Volume Control should be pre-set to the proper level to obtain proper automatic radio operation.

If the Alarm Knob is in the out position the "buzzer" will be sounded shortly after the radio goes on.

If it is desired to have the alarm only, independent of the radio pull the Alarm Knob out and set the Control Knob to Off.

Another combination of operations is provided with the Sleep Knob, which will turn off the radio automatically at night (see "TO TURN RADIO AND APPLIANCE OFF AUTOMATICALLY") and, provided the Control Knob is in Wake-Up position, the radio will turn on automatically in the morning.

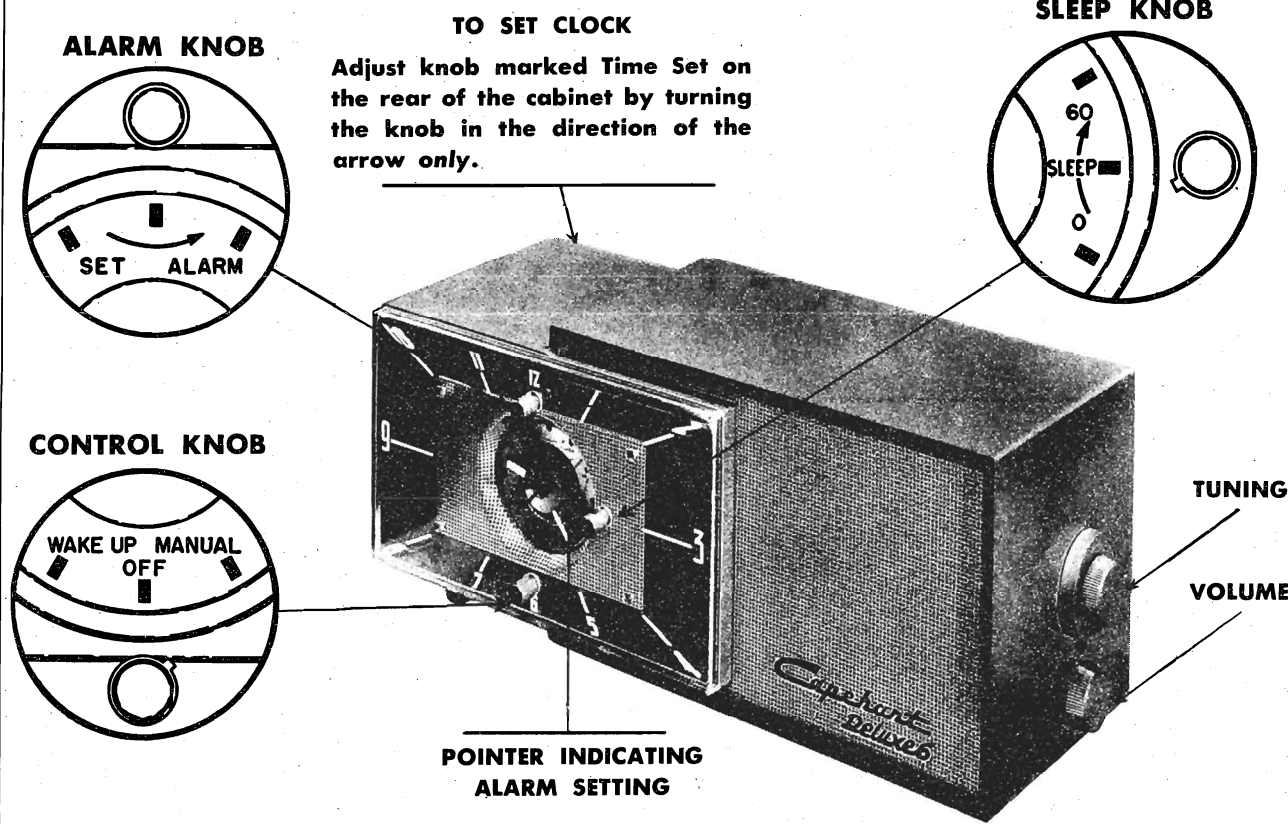

TO TURN RADIO AND APPLIANCE OFF AUTOMATICALLY

Turn the Sleep Knob to the right and if the small projection on the Sleep Knob is used as a rough indicator a reasonable degree of accuracy can be obtained in adjusting for any period of operation up to 60 minutes. For instance, if 15 minutes of operation is desired the Sleep Knob should be adjusted approximately one-quarter of its full rotation. If it is not desired to have the radio turned on automatically in the morning, then set the Control Knob to **Off** before you set the Sleep Knob for automatic turnoff.

TO TURN ON APPLIANCE AUTOMATICALLY

Plug electrical appliance into outlet on rear of radio, set Control Knob at Wake-Up position and the appliance will be turned on at the time determined by the setting of the Alarm Knob. The radio will operate at the same time, but if radio music is not desired the Volume Knob should be turned fully to the left.

TO PLAY RADIO MANUALLY

1. Set the Control Knob to the manual position.
2. Adjust Tuning Knob for desired station.
3. Set the Volume Control for desired sound volume.

MODEL TC-62,
Ch. CR-71

REMOVAL AND SERVICE OF CLOCK MECHANISM

SERVICE

The clock mechanism used in this unit is not to be serviced by anyone other than an authorized Telechron Service Agency (see pages 7 and 8 of this manual for a listing of these agencies). When it is determined that the clock requires adjustment or repair, remove the clock mechanism from the cabinet (as per the following instructions) and return the clock mechanism to your Capehart distributor or an agency specified by him. If the clock mechanism is to be shipped by mail or express, be certain that it is adequately protected and properly packed.

TO REMOVE CLOCK

1. Remove (pull off) the three knobs from the front of the clock.
2. Remove the six (6) Phillips-head screws which fasten the back of the cabinet.

3. Remove the four (4) Phillips-head screws which secure the clock to the inside of the cabinet.
4. Remove the 35W4 and 35C5 tubes to facilitate removal of the clock.
5. Pull clock out of the cabinet by sliding it to the left and back.
6. Remove the three hex nuts which fasten the metal cover to the clock. Keep the metal cover and hardware (4 Phillips screws, 3 hex nuts, and 3 fibre washers) with the cabinet, do not return this material with the clock.
7. Unsolder four (4) electrical leads from the clock.

NOTE: To re-install the clock follow the above procedure in reverse.

TO REMOVE CABINET BACK:
REMOVE SIX (6) PHILLIPS SCREWS

TO REMOVE CLOCK FROM CABINET:
REMOVE FOUR (4) PHILLIPS SCREWS

TO REMOVE CLOCK COVER:
REMOVE THREE (3) HEX-NUTS

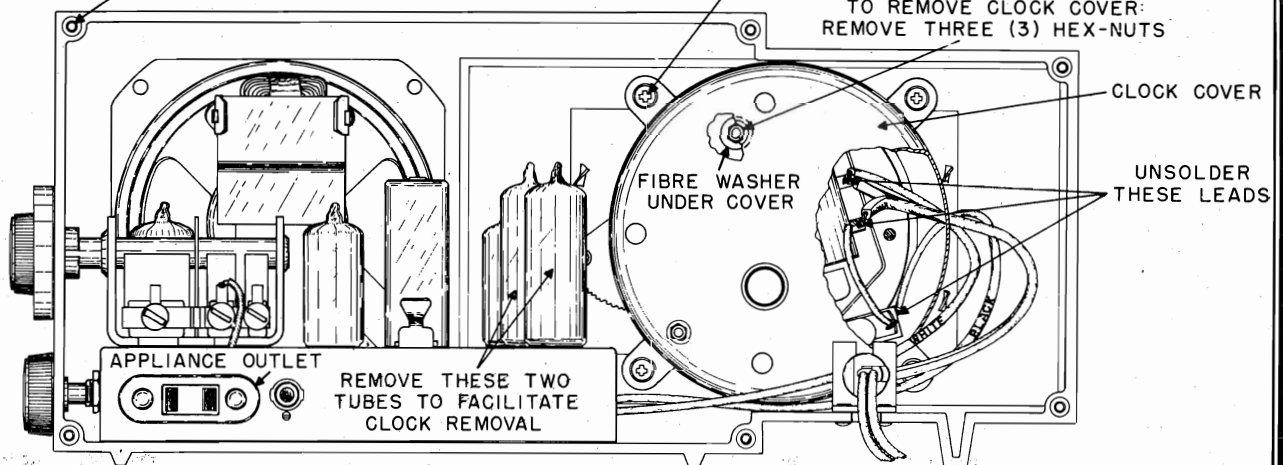

MODEL TC-62,
Ch. CR-71

TC-62 ALIGNMENT INSTRUCTIONS

Equipment required:

1. Calibrated R.F. Signal Generator (Signal from 455KC to 1620KC).
2. Low Range Output Meter.

Alignment:

- a. Turn set on, adjust volume to maximum.
- b. See that dial pointer coincides with calibration marks at extremes of dial scale.
- c. Connect output meter across speaker voice coil.

Step No.	Set R.F. Generator At	Connect Generator To	Set Gang Condenser To	Adjust	To Obtain
1	455 Kc.	Antenna section of Gang Condenser	Fully open. Disable osc. section of tuning gang.	I.F. slugs T103 T104	Max.
2	1620 Kc.	Antenna section of Gang Condenser	Fully open.	Osc. Trimmer C103D	Max.
3	537 Kc.	Antenna section of Gang Condenser	Fully closed.	Osc. Coil T102	Max.
4	1500 Kc.	Antenna section of Gang Condenser	1500 Kc.	Mixer Trimmer C103E	Max.
5	600 Kc.	Antenna section of Gang Condenser	600 Kc.	Mixer Coil T101	Max.
6	1500 Kc.	Loosely couple to Loop antenna	1500 Kc.	Antenna Trimmer C103F	Max.

CHASSIS LAYOUT

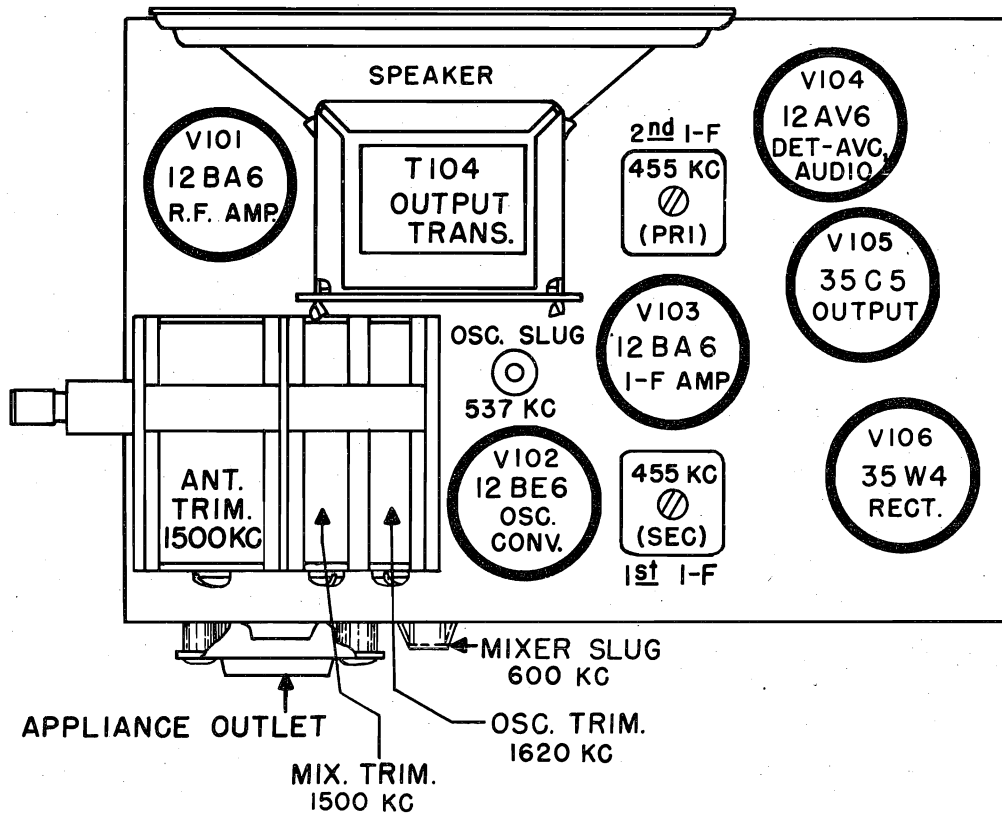

SCHEMATIC DIAGRAM

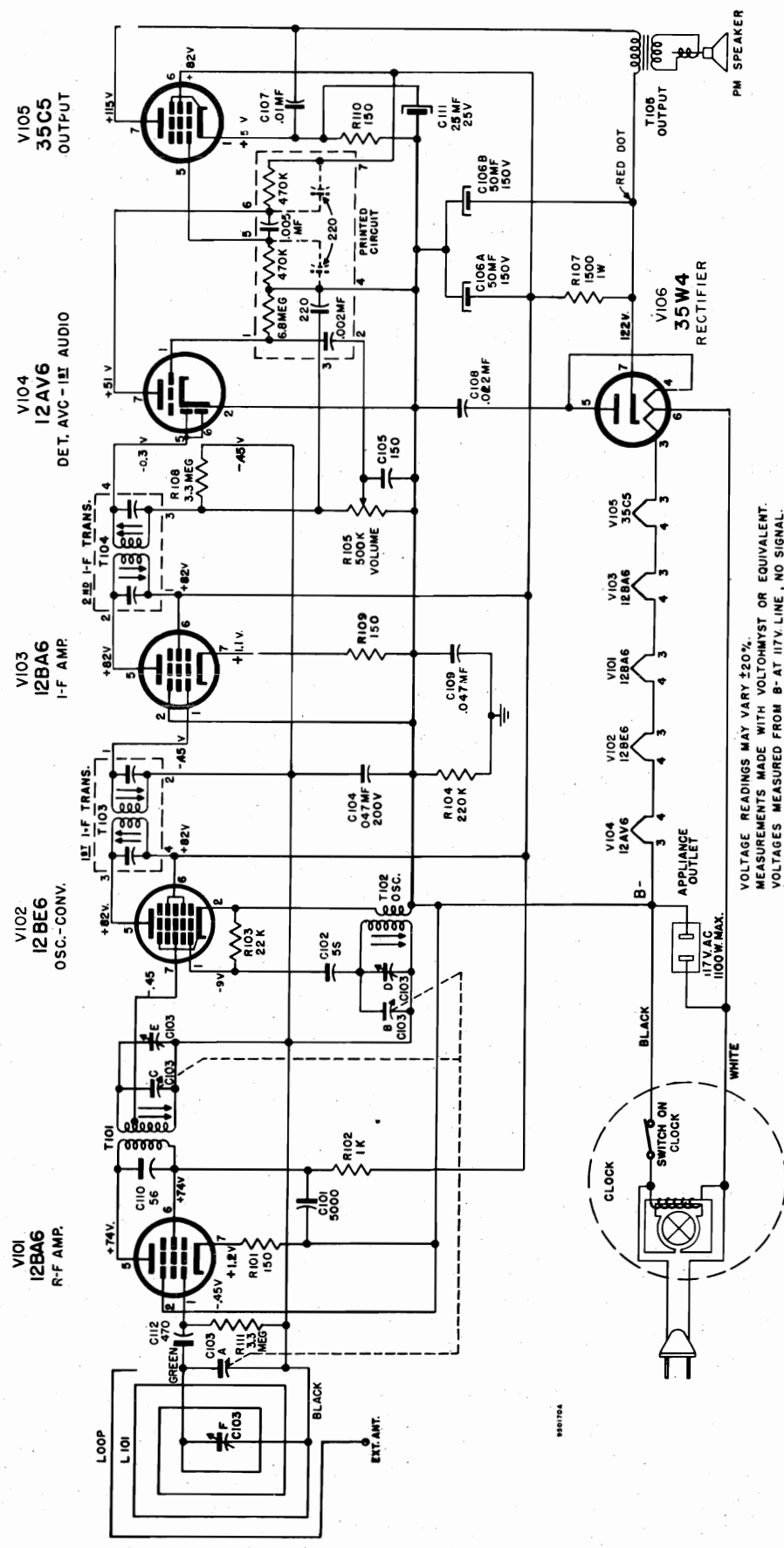

VOLTAGE READINGS MAY VARY ±20%.
MEASUREMENTS MADE WITH VOLTOHMST OR EQUIVALENT.
VOLTAGES MEASURED FROM B- AT 117V. LINE, NO SIGNAL.
UNLESS OTHERWISE NOTED: RESISTORS 1/2 WATT CARBON
CAPACITORS 500V.

MODEL TC-62,
Ch. CR-71

Ref. No. Description **PARTS PRICE LIST** Part No. List

INDUCTANCES

L101	Loop Antenna	750207A-2	\$ 1.30
T101	Mixer Coil	453247B-1	1.30
T102	Oscillator Coil	453248A-1	.90
T103	1st I. F. Transformer	452243A-1	1.40
T104	2nd I. F. Transformer	452243A-1	1.40
T105	Output Transformer (Part of Assembly No. 750373A-1)		

RESISTORS

R101, 109, 110	150 ohm 1/2 w. 10%	3229-151	.10
R102	1K 1/2 w. 10%	3229-102	.10
R103	22K 1/2 w. 10%	3229-223	.10
R104	220K 1/2 w. 10%	3229-224	.10
R105	500K Volume Control	452241A-1	.80
R107	1500 ohm 1 w. 10%	3232-152	.10
R108	3.3 meg. 1/2 w. 20%	3230-335	.10

CAPACITORS

C101	5000 mmf. Ceramic Disc	450469A-1	.25
C102, 110	56 mmf. Ceramic	2241-554	.25
C103 A,B,C,D,E,F	Variable Tuning Capacitor	650227A-1	3.50
C104	.047 mfd. 200 V.	2246-4730	.20
C105	150 mmf. Ceramic	2240-021	.20
C106	50 mfd. 50 mfd. 150 V. Electrolytic	650326A-1	2.10
C107	.01 mfd. 600 V.	2248-1030	.20
C108	.022 mfd. 600 V.	2248-2230	.25
C109	.047 mfd. 600 V.	2248-4730	.30
C111	25 mfd. 25 V. Electrolytic	452132A-3	1.00

MISCELLANEOUS

Speaker and Output Transformer Assembly	750373A-1	6.00
Clock	750377A-1	17.15
Appliance A. C. Outlet	450427A-1	.30
Line Cord	650171A-3	.60
Speaker Grille	650634A-1	1.20
Clock Grille	650323A-1	.85
Clock Grille (Sage Green)	650323A-2	1.25
Capehart Insignia	452188B-2	.25
Decorative Stud	452235A-1	.10
Speednut	452696A-14	.10
Clock Escutcheon	750198A-1	2.05
Clock Escutcheon (Ivory)	750198A-2	2.05
Insignia "Deluxe 6"	453314A-2	.15

CABINET PARTS

Cabinet Assembly (Grey-Blue)	453246A-G1	7.20
(Ivory)	453246A-G4	7.20
(Ebony)	453246A-G5	7.20
(Sage Green)	453246A-G7	7.20
Cabinet Back (Grey-Blue)	850130A-1	2.75
(Ivory)	850130A-4	2.75
(Ebony)	850130A-5	2.75
(Sage Green)	850130A-7	2.75
Knob, Tuning Dial (Grey-Blue)	650325A-1	.35
(Ivory)	650325A-4	.35
(Ebony)	650325A-5	.35
(Sage Green)	650325A-12	.35
Knob, Radio (Grey-Blue)	452240A-1	.15
(Ivory)	452240A-4	.15
(Ebony)	452240A-5	.15
(Sage Green)	452240A-11	.15
Knob Clock (Grey-Blue)	453134A-1	.10
(Ivory)	453134A-4	.10
(Ebony)	453134A-5	.10
(Sage Green)	453134A-7	.10

**Use only genuine Capehart replacement parts.
All prices subject to change without notice.**

MODELS E30BE, E30GN,
E30MN, E30TN, Ch. 30E,
30E-1

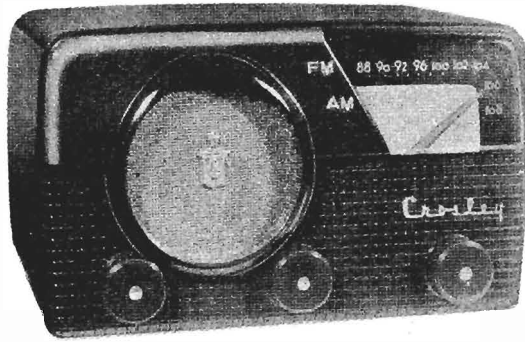

Model No.	Cabinet Color
E30BE	Blue
E30GN	Green
E30MN	Maroon
E30TN	Tan

DESCRIPTION

TYPE: Seven-tube, two-band, superheterodyne.
FREQUENCY RANGE: Standard Broadcast Band (AM); 540 to 1620 kc.
 Frequency Modulation Band (FM); 88 to 108 megacycles.
INTERMEDIATE FREQUENCY: Standard Broadcast Band; 455 kc.
 Frequency Modulation Band; 10.7 mc.
FM ANTENNA INPUT IMPEDANCE: 75 ohms balanced.
POWER SUPPLY: a.c.—d.c.
VOLTAGE RATING: 105-125 volts.
POWER CONSUMPTION: 40 watts at normal power supply voltage (117 volts).
POWER OUTPUT: 1 watt maximum.

TUBE COMPLEMENT:

Symbol No.	Type	Function
V1	12BE6	Converter (AM)
V2	35C5	Audio Output
V3	12BA6	R. F. Amplifier (FM)
V4	12BA6	I. F. Amplifier (AM & FM)
V5	12BA6	2nd I. F. Amplifier & AVC (FM)
V6	12AT7	Oscillator & Mixer (FM)
V7	19T8	Detector & 1st A.F. Ampl. (AM & FM); AVC (AM)
SR1	Selenium Rectifier	

DIAL BULB: 7 w., 120 v., Candelabra Base

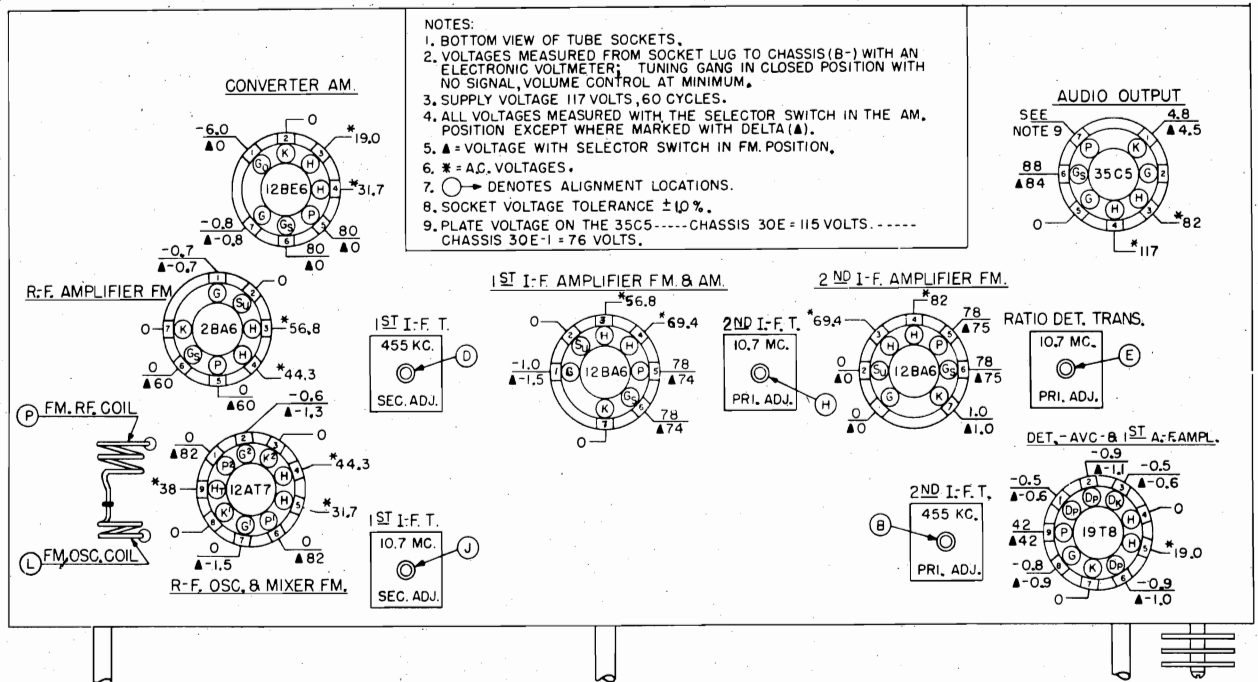

SOCKET VOLTAGE CHART

MODELS E30BE, E30GN, E30MN,
E30TN, Ch. 30E, 30E-1

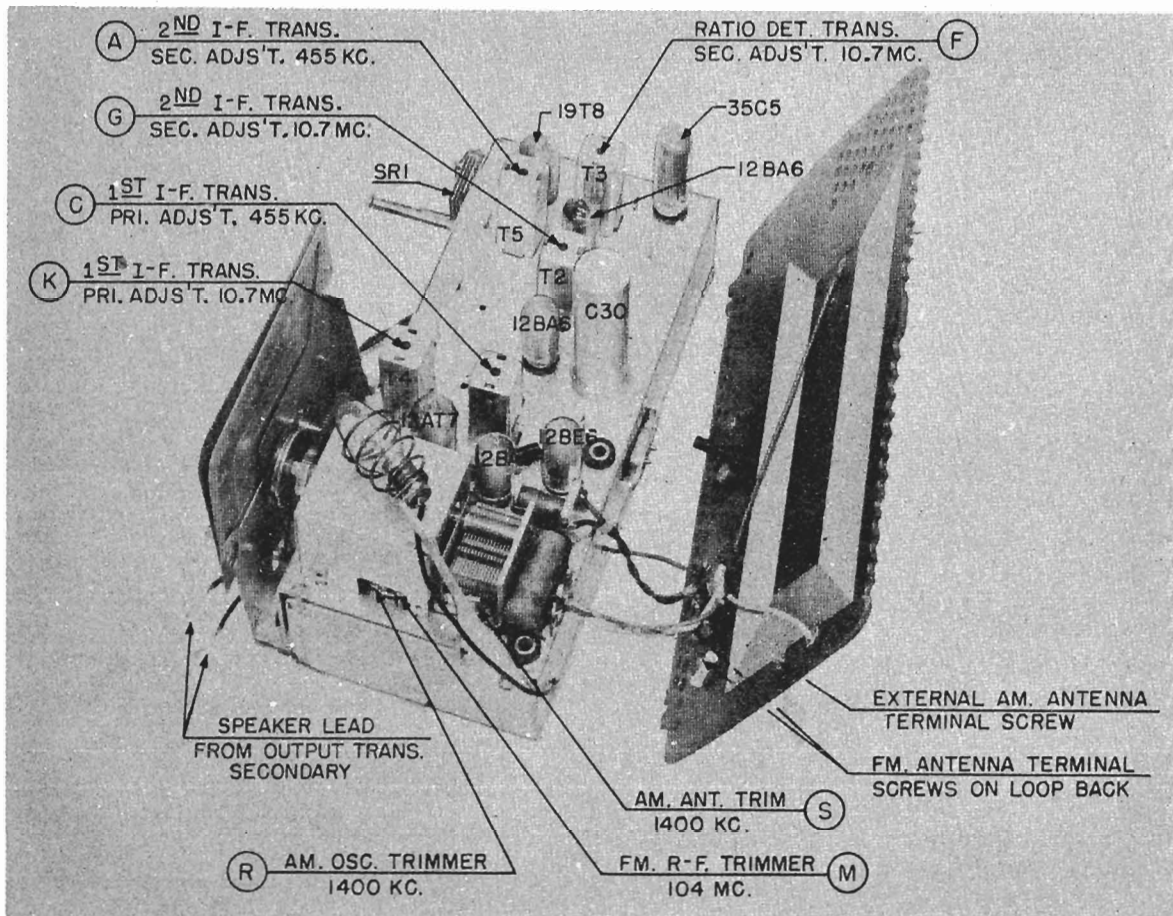

CHASSIS TOP VIEW SHOWING ALIGNMENT ADJUSTMENTS

When using direct current it may be necessary to reverse the position of the power plug in the electric outlet for correct polarity.

Reversing the position of the power plug when alternating current is used may reduce power hum.

Under no circumstances should a ground be connected to this receiver.

Never place the receiver chassis on a metal bench or grounded object when the power plug is connected to the electric outlet. To avoid shock when making repairs or adjustments, do not permit any part of the body to contact grounded metal objects.

ALIGNMENT PROCEDURE

This receiver has been aligned at the factory for best performance and no attempt should be made to realign it unless the proper test equipment is available.

1. Turn the tuning condenser to full mesh, against stop, and set the dial pointer to the reference point at the "88" end of the dial.
2. Set the tone control knob to the full treble position (extreme right).
3. For Amplitude Modulated signal readings, connect output meter across voice coil (3.2 ohms).

**MODELS E30BE, E30GN, E30MN,
E30TN, Ch. 30E, 30E-1**

4. All Amplitude Modulated input signals are modulated 30% at 400 cycles with the High side of the signal generator connected to receiver as indicated in the alignment chart. Connect the low side of signal generator through a 0.1 mfd. condenser to the receiver chassis. If hum is encountered, use a 1 to 1 isolating transformer between the power line outlet and the receiver power line cord. Then connect the low side of the signal generator directly to the receiver chassis.
5. All Frequency Modulated signals are modulated 30% at 400 cycles. 30% modulation is equal to a deviation of 22.5 kilocycles.
6. Turn the volume control to maximum clockwise position and adjust signal generator output to produce a noticeable output meter reading. Keep signal generator output as low as possible to prevent AVC action in the receiver.
7. Disconnect short wire, with spade lug, from F.M. Antenna Terminal.

ALIGNMENT CHART

Align- ment Se- quence	Signal Generator Output			Position of		Adjust	Type of Selectivity Curve	Remarks	
	Frequency	In Series With	To	Range Switch	Tuning Dial or Tun. Cap.				
1	455 kc.	.05 mfd.	V4 grid pin 1	AM	Open	A & B	Single peak		
2	455 kc.	.05 mfd.	V1 grid pin 7	AM	Open	C & D	Single peak	Retouch A & B	
3	10.7 mc.	.05 mfd.	V5 grid pin 1	FM	Closed	E	Single peak	See note 1 & 2	
4	10.7 mc.	.05 mfd.	V5 grid pin 1	FM	Closed	F	—	Balance to zero volts. Note 3	
5	10.7 mc.	.05 mfd.	V4 plate pin 5	FM	Closed	E & G	Single peak	See note 4 repeat adj. of E & G for max. alignment	
6	10.7 mc.	.05 mfd.	V4 grid pin 1	FM	Closed	H	Single peak	Note 4	
7	10.7 mc.	.05 mfd.	Stator center gang section	FM	Closed	J, K & H	Single peak	Note 4 & 5	
8	98 mc.	FM Dummy *Antenna	FM Ant. Term.	FM	98 mc.	L	—	Note 6	
19	104 mc.	FM Dummy *Antenna	FM Ant. Term.	FM	104 mc.	M	—	Note 7	
10	92 mc.	FM Dummy *Antenna	FM Ant. Term.	FM	92 mc.	P	—	Note 8	
11	Repeat steps 9 and 10 until no further improvement is noted:								
12	1400 kc.	200 mmf.	Ext. Ant. Term.	AM	1400 kc.	R & S	—	Adjust S for max. output	

MODELS E30BE,
E30GN, E30MN,
E30TN, Ch. 30E,
30E-1

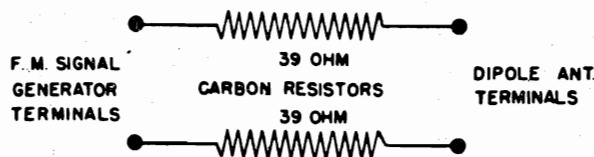

* DUMMY ANTENNA

ALIGNMENT NOTES

1. Use an unmodulated signal generator with approximately 100,000 mv. output.
2. Connect the electronic voltmeter across the 27,000 ohm diode load resistor (R6).
3. Connect two 100,000 ohm 5% carbon resistors in series, connect these resistors across the 4 mfd. stabilizing capacitor (C17) in the diode circuit, connect the electronic voltmeter between the output of the RF filter network (C22) and the midpoint of the two 100,000 ohm resistors. Align secondary core (F) of T3 for zero volts, first using a high scale on the electronic voltmeter and then switching to the lowest scale for close balance.
4. Use an unmodulated signal. Electronic voltmeter connected across 27,000 ohm load resistor (R6). Limit output of signal generator so that the reading on the electronic voltmeter will not exceed 5 volts.
5. Remove the two 100,000 ohm resistors and electronic voltmeter after alignment.
6. Adjust turns on FM oscillator coil by spreading or squeezing together, so that 98 megacycle signal falls on 98 megacycles on the dial.
7. Rock gang while adjusting FM. RF trimmer until maximum output meter reading is obtained, or align for maximum noise level at zero signal.
8. Adjust turns on FM. RF coil until maximum output meter reading is obtained.

MEGACYCLES TO CHANNEL NUMBERS "FM" BAND

Frequency in Megacycles	Channel No.	Frequency in Megacycles	Channel No.
87.9	200	98.9	255
88.9	205	99.9	260
89.9	210	100.9	265
90.9	215	101.9	270
91.9	220	102.9	275
92.9	225	103.9	280
93.9	230	104.9	285
94.9	235	105.9	290
95.9	240	106.9	295
96.9	245	107.9	300
97.9	250		

To find the frequency in megacycles for CHANNEL NUMBERS between those given above, add .2 megacycles for every whole number added to the CHANNEL NUMBER; for example Channel 204 would be 88.7 megacycles and 251 would be 98.1 megacycles.

MODELS E30BE, E30GN,
E30MN, E30TN, Ch. 30E,
30E-1

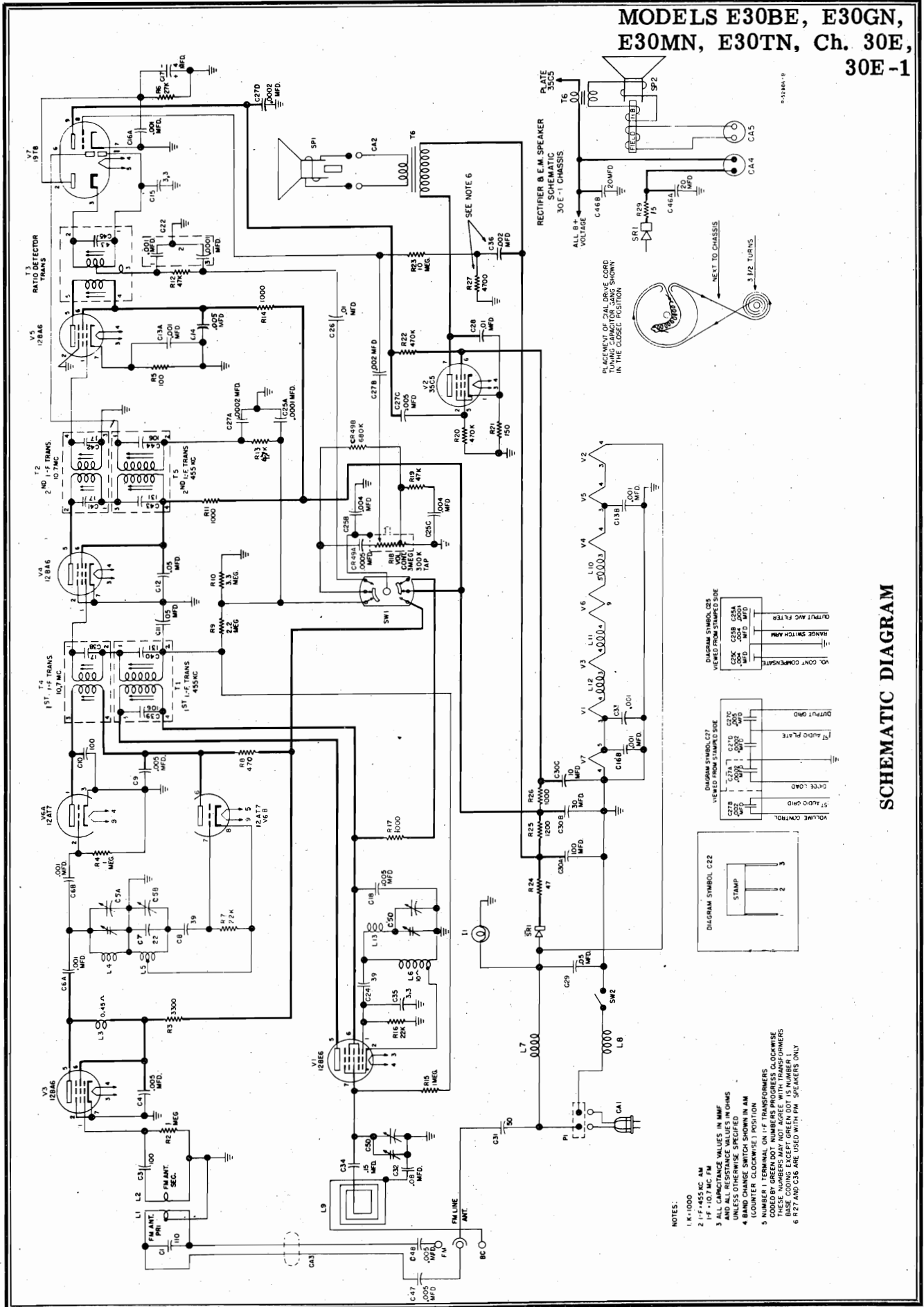

- NOTES:
- 1 K = 1000
 - 1 M = 1,000,000
 - ALL CAPACITANCE VALUES IN MMF AND ALL RESISTANCE VALUES IN OHMS UNLESS OTHERWISE SPECIFIED
 - RESISTANCE VALUES IN K (KILOHMS) AND M (MEG OHMS) UNLESS OTHERWISE SPECIFIED
 - NUMBER 1 TERMINAL ON I-F TRANSFORMERS CODED BY GREEN DOT NUMBERS PROGRESS CLOCKWISE THESE NUMBERS MAY NOT AGREE WITH TRANSFORMERS MANUFACTURER'S LISTINGS
 - R27 AND C36 ARE USED WITH PM SPEAKERS ONLY

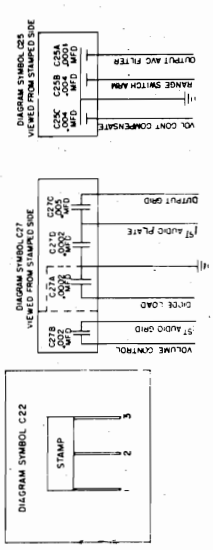

SCHEMATIC DIAGRAM

MODELS E30BE,
E30GN, E30MN,
E30TN, Ch. 30E,
30E-1

PARTS LIST

Symbol No.	Part No.	Description	Symbol No.	Part No.	Description
C1	W-145913-2	Capacitor, 110 mmf., 5%, 500 v., ceramic	R19	39373-67.	Resistor, 47,000 ohm, 1/2 w.
C3	C-137727-1	Capacitor, 100 mmf., 500 v., ceramic	R20	39373-87	Resistor, 470,000 ohm, 1/2 w.
C4	C-144675-2	Capacitor, .005 mfd., 500 v., disc ceramic	R21	39374-15	Resistor, 150 ohm, 10%, 1/2 w.
C5A	C-152824	Capacitor, Variable	R22	39373-87	Resistor, 470,000 ohm, 1/2 w.
C5B		Capacitor, Variable	R23	39373-107	Resistor, 10 megohm, 1/2 w.
C5C		Capacitor, Variable	R24	39374-185	Resistor, 47 ohm, 10%, 2 w.
C5D		Capacitor, Variable	R25	39374-202	Resistor, 1200 ohm, 10%, 2 w.
C6A	C-144675-7	Capacitor, .001 mfd., 500 v. } Two section	R26	39374-25	Resistor, 1000 ohm, 10%, 1/2 w.
C6B		Capacitor, .001 mfd., 500 v. } disc ceramic	R27	39374-33	Resistor, 4700 ohm, 10%, 1/2 w.
C7	C-137727-98	Capacitor, 22 mmf., 2%, 500 v., ceramic	R29	39373-3	Resistor, 15 ohm, 1/2 w (chassis 30E-1 only)
C8	C-137727-109	Capacitor, 39 mmf., 10%, 200 v., ceramic	CA1	C-132300-6	Cable & Plug Assy., Power
C9	C-137727-121	Capacitor, 5000 mmf., 500 v., ceramic	CA4	B-139727-9	Cable & Plug Assy. (chassis 30E-1 only)
C10	C-137727-90	Capacitor, 100 mmf., 5%, 500 v., ceramic	I1	W-145851	Bulb (Dial), 7 w., 120 v., Candelabra Base
C11	39001-17	Capacitor, .05 mfd., 600 v., paper	SP1	C-145768	Speaker
C12	39001-17	Capacitor, .05 mfd., 600 v., paper	SP2	AD-151190-1	Speaker 5 1/4"E.M.
C13A	C-144675-7	Capacitor, .001 mfd., 500 v. } Two section	SR1	B-145370	Rectifier, Selenium
C13B		Capacitor, .001 mfd., 500 v. } disc ceramic	SW1	W-145300-2	Switch, Band Change
C14	C-137727-121	Capacitor, 5000 mmf., 500 v., ceramic	SW2	Part of R18	Switch, Power
C15	C-137398-5	Capacitor, 3.3 mmf., 500 v.	T1	AC-139919-3	Transformer, 1st I.F. (455 kc.)
C16A	C-144675-7	Capacitor, .001 mfd., 500 v. } Two section	T2	D-145025-1	Transformer, 2nd I.F. (10.7 mc.)
C16B		Capacitor, .001 mfd., 500 v. } disc ceramic	T3	C-145193-1	Transformer, Ratio Detector
C17	B-142958	Capacitor, 4 mfd., 50 v., Electrolytic	T4	D-145025-3	Transformer, 1st I.F. (10.7 mc.)
C18	C-137727-121	Capacitor, 5000 mmf., 500 v., ceramic	T5	AC-139919-3	Transformer, 2nd I.F. (455 kc.)
C22	C-144675-12	Capacitor, .001 mfd., 500 v. } Two section	T6	138131-1	Transformer, Output
C22		Capacitor, .0001 mfd., 500 v. } disc ceramic	L1	B-143322	Coil, F.M. Antenna Primary
C24	C-137727-109	Capacitor, 39 mmf. 10%, 200 v., ceramic	L2	AW-145724	Coil Assy., F.M. Antenna Secondary
C25A	C-144675-18	Capacitor, .0001 mfd., 500 v. } Three sec-	L3	AW-143837	Choke Assy., R.F. (F.M.)
C25B		Capacitor, .004 mfd., 500 v. } tion disc	L4	AA-151747	Coil Assy., R.F. (F.M.)
C25C		Capacitor, .004 mfd., 500 v. } ceramic	L5	AA-151746	Coil Assy., Oscillator (F.M.)
C26	39001-13	Capacitor, .01 mfd., 600 v., paper	L6	AC-152448	Coil Assy., Oscillator (A.M.)
C27A	C-144675-1	Capacitor, .0002 mfd., 500 v. } Four sec-	L7	AW-143934	Choke Assy., R.F.
C27B		Capacitor, .002 mfd., 500 v. } tion disc	L8	AW-143934	Choke Assy., R.F.
C27C		Capacitor, .005 mfd., 500 v. } ceramic	L9	AC-152873	Loop Antenna, Back & Power Cable Assy.
C27D		Capacitor, .0002 mfd., 500 v. } ceramic	L10	AW-149187	Choke Assy.
C28	39001-13	Capacitor, .01 mfd., 600 v., paper	L11	AW-149187	Choke Assy.
C29	39001-17	Capacitor, .05 mfd., 600 v., paper	L12	AC-149187	Choke Assy.
C30A	B-149183	Capacitor, 100 mfd., 150 v. } Three sec-	L13	AC-143837	Choke Assy.
C30B		Capacitor, 30 mfd., 150 v. } tion elec-	P1	W-139900	Plug, Interlock
C30C		Capacitor, 10 mfd., 150 v. } trolytic	C-152811	C-152811	Background, Dial
C31	B-143686-1	Capacitor, 50 mmf., 500 v., molded disc ceramic	AB-149145-2	AB-149145-2	Baffle Assembly, Speaker
C32	39001-85	Capacitor, .08 mfd., 600 v., paper	AW-149073	AW-149073	Bracket Assembly, Dial Pointer
C33	C-144675-14	Capacitor, 1000 mmf., 500 v., disc ceramic	AW-145697	AW-145697	Bushing & Insulator, Drive Shaft
C34	39001-20	Capacitor, .15 mfd., 600 v., paper	AC-152861-4	AC-152861-4	Cabinet (E 30 BE)
C35	W-137398-5	Capacitor, 3.3 mmf., 500 v.	AC-152861-3	AC-152861-3	Cabinet (E 30 GN)
C36	39001-74	Capacitor, .002 mfd., 600 v., paper	AC-152861-2	AC-152861-2	Cabinet (E 30 MN)
C38	Part of T4	Capacitor, 17 mmf., 3%	AC-152861-1	AC-152861-1	Cabinet (E 30 TN)
C39	Part of T1	Capacitor, 106 mmf., 5%	W-131154-1	W-131154-1	Cotter (External), Drive Shaft
C40	Part of T1	Capacitor, 131 mmf., 5%	C-152832-4	C-152832-4	Dial (E 30 BE)
C41	Part of T2	Capacitor, 17 mmf., 3%	C-152832-3	C-152832-3	Dial (E 30 GN)
C42	Part of T2	Capacitor, 17 mmf., 3%	C-152832-2	C-152832-2	Dial (E 30 MN)
C43	Part of T5	Capacitor, 131 mmf., 5%	C-152832-1	C-152832-1	Dial (E 30 TN)
C44	Part of T5	Capacitor, 106 mmf., 5%	W-138853	W-138853	Insulator, Volume Control
C45	Part of T3	Capacitor, 43 mmf., 5%	B-149065-1	B-149065-1	Knob (E 30 TN)
46A	B-151670	Capacitor, 20 mfd., 150 v. } Two section	B-149065-2	B-149065-2	Knob (E 30 GN)
46B		Capacitor, 20 mfd., 150 v. } Electrolytic	B-149065-6	B-149065-6	Knob (E 30 MN)
C47	C-137727-121	Capacitor, 5000 mmf., 500 v., ceramic	B-149065-7	B-149065-7	Knob (E 30 BE)
C48	C-137727-121	Capacitor, 5000 mmf., 500 v., ceramic	C-151652	C-151652	Lens, Dial
CR49A	C-142951-12	Capacitor, 500 mmf., 500 v. } Capacitor-	B-148080-4	B-148080-4	Medallion
CR49B		Resistor, 680,000 ohm, 1/5 w } Resistor unit.	A-152814	A-152814	Pointer, Dial
R2	39373-92	Resistor, 1 megohm, 1/2 w.	W-143206-4	W-143206-4	Shaft, Dial Drive
R3	39373-44	Resistor, 3300 ohm, 1/2 w.	AB-152842	AB-152842	Shaft & Gear Assy., Dial Pointer
R4	39373-92	Resistor, 1 megohm, 1/2 w.	W-139040	W-139040	Shock Mount, Sub-Chassis
R5	39373-14	Resistor, 100 ohm, 1/2 w.	AB-152902	AB-152902	Socket & Bracket Assy., Dial Light
R6	39374-42	Resistor, 27,000 ohm, 10% 1/2 w.	W-144732	W-144732	Socket, Tube (V6)
R7	39374-41	Resistor, 22,000 ohm, 10%, 1/2 w.	W-145607	W-145607	Socket, Tube (V7)
R8	39373-26	Resistor, 470 ohm, 1/2 w.	W-142761	W-142761	Socket, Tube (V1, V3)
R9	39373-97	Resistor, 2.2 megohm, 1/2 w.	39462-1	39462-1	Socket, Tube (V2)
R10	39373-100	Resistor, 3.3 megohm, 1/2 w.	39462-2	39462-2	Socket, Tube (V4, V5)
R11	39373-33	Resistor, 1000 ohm, 1/2 w.	W-149096	W-149096	Spring, Gear
R12	39373-67	Resistor, 47,000 ohm, 1/2 w.	W-51752	W-51752	Spring, Drive Cord
R13	39373-67	Resistor, 47,000 ohm, 1/2 w.	W-139121	W-139121	Stud (Insulated), Chassis Mtg.
R14	39373-33	Resistor, 1000 ohm, 1/2 w.	W-138976	W-138976	Washer (Shouldered), Volume Control
R15	39373-92	Resistor, 1 megohm, 1/2 w.	W-134916	W-134916	Washer (Spring), Drive Shaft
R16	39373-60	Resistor, 22,000 ohm, 1/2 w.			
R17	39373-33	Resistor, 1000 ohm, 1/2 w.			
R18	B149184	Control, Volume (3 megohm - Tap 300,000 ohm)			

MODELS E15BE, CE, SL, TN, WE, E20GN, GY, MN, TN, Ch. 15-20E

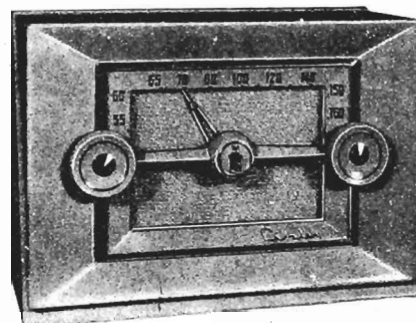
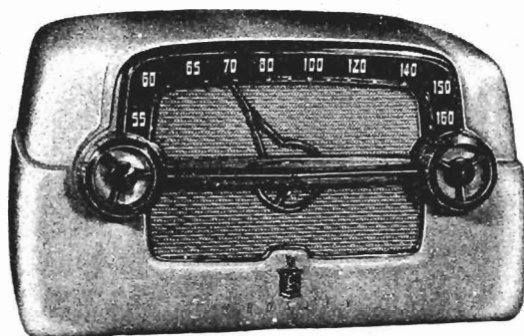

Model	Color
E 15 WE	White
E 15 BE	Blue
E 15 TN	Tan
E 15 SL	Steel Blue
E 15 CE	Chartreuse

Model	Color
E 20 MN	Maroon
E 20 GN	Green
E 20 GY	Grey
E 20 TN	Tan

DESCRIPTION

TYPE: Five-tube, single band, Superheterodyne.

FREQUENCY RANGE: 540 to 1600 kc.

INTERMEDIATE FREQUENCY: 455 kc.

POWER SUPPLY: a.c.-d.c.

VOLTAGE RATING: 105-125 volts.

POWER CONSUMPTION: 30 watts maximum.

POWER OUTPUT: 1 watt maximum.

TUBE COMPLEMENT:

Type	Function
12BE6	Converter
12BA6	I. F. Amplifier
12AV6	Detector, AVC, 1st A. F. Amplifier
50C5	A. F. Power Output
35W4	Rectifier

When using direct current it may be necessary to reverse the position of the power plug in the electric outlet for correct polarity.

Reversing the position of the power plug when alternating current is used may reduce hum.

Under no circumstances should a ground be connected to this receiver.

PHONOGRAPH CONNECTION — To use a record player with this receiver insert the pickup plug of the record player into the Phono jack on back of receiver. Then slide the Radio-Phono Switch on the back of the receiver to the "Phono" position. Connect the power cord of the record player to a convenient electric outlet of the correct voltage and frequency. Operate the record player in the normal manner.

ALIGNMENT PROCEDURE

Note: Before removing the chassis from the cabinet, turn the tuning control completely counter-clockwise and push the dial pointer down so as to clear opening in grille.

1. Connect an output meter across the speaker voice coil.
2. The r.f. signal input from the signal generator should be connected as indicated in the alignment chart. Connect the signal generator ground to lug as shown in Chassis Top View.
3. Turn the volume control on full and adjust the signal generator output to produce approximately midscale deflection of the output meter, but maintain signal generator output as low as possible to prevent AVC action in the receiver.

MODELS E15BE, CE, SL, TN, WE,
E20GN, GY, MN, TN, Ch. 15-20E

ALIGNMENT CHART

Alignment adjustment locations are shown on page 9 "CHASSIS, TOP VIEW."

Alignment Sequence	Signal Generator Output		Position of Dial pointer	Adjust for Maximum Output
	Frequency in KC	In Series with To		
1	455	200 mmf. External Ant. Screw	1620	A, B, C & D (See Note 1.)
2	1620	200 mmf. External Ant. Screw	1620	E (See Note 2.)
3	1400	200 mmf. External Ant. Screw	Tune to Signal	F (See Note 2.)

ALIGNMENT NOTES

1. Repeat adjustments (A, B, C & D) in sequence, until maximum output is obtained.
2. The loop antenna must be positioned with respect to the chassis to simulate its position when chassis and loop are fastened in cabinet.
3. After the chassis is installed in the cabinet, set the pointer for proper dial calibration.

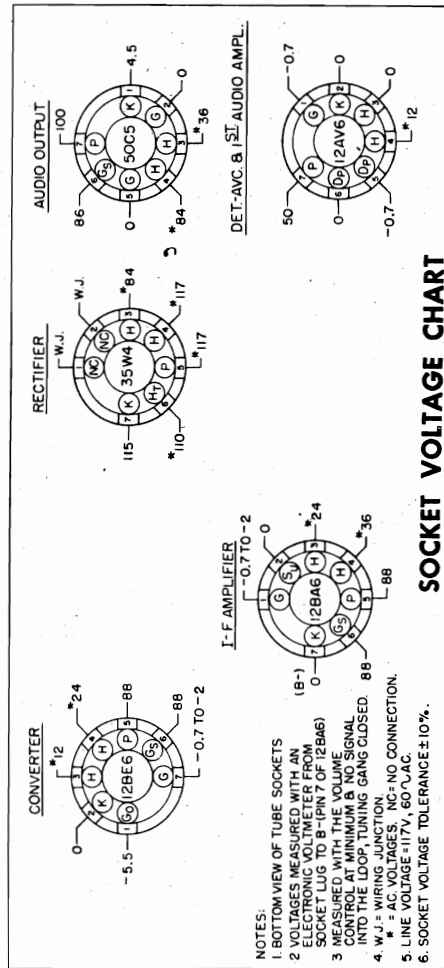

MODELS E15BE, CE, SL, TN, WE, E20GN, GY, MN, TN, Ch. 15-20E

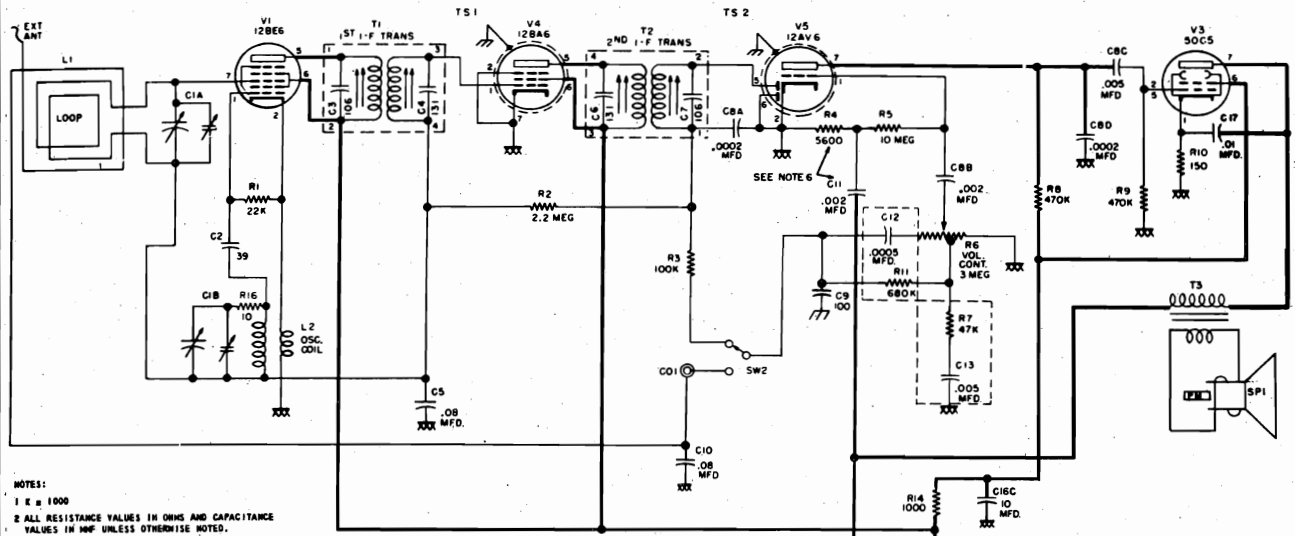

- NOTES:
 1 R = 1000
 2 ALL RESISTANCE VALUES IN OHMS AND CAPACITANCE VALUES IN MUF UNLESS OTHERWISE NOTED.
 3 NUMBER ONE TERMINAL ON I.F. TRANSFORMERS CODED WITH GREEN DOT, NUMBERS PROGRESS CLOCKWISE.
 4 I.F. = 455 KC.
 5 = CHASSIS
 XXX = COMMON WIRING
 6 R4 AND C11 USED WITH PH. SPEAKERS ONLY.

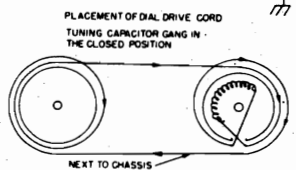
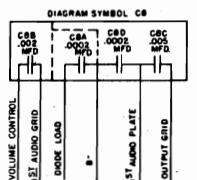

SCHEMATIC DIAGRAM

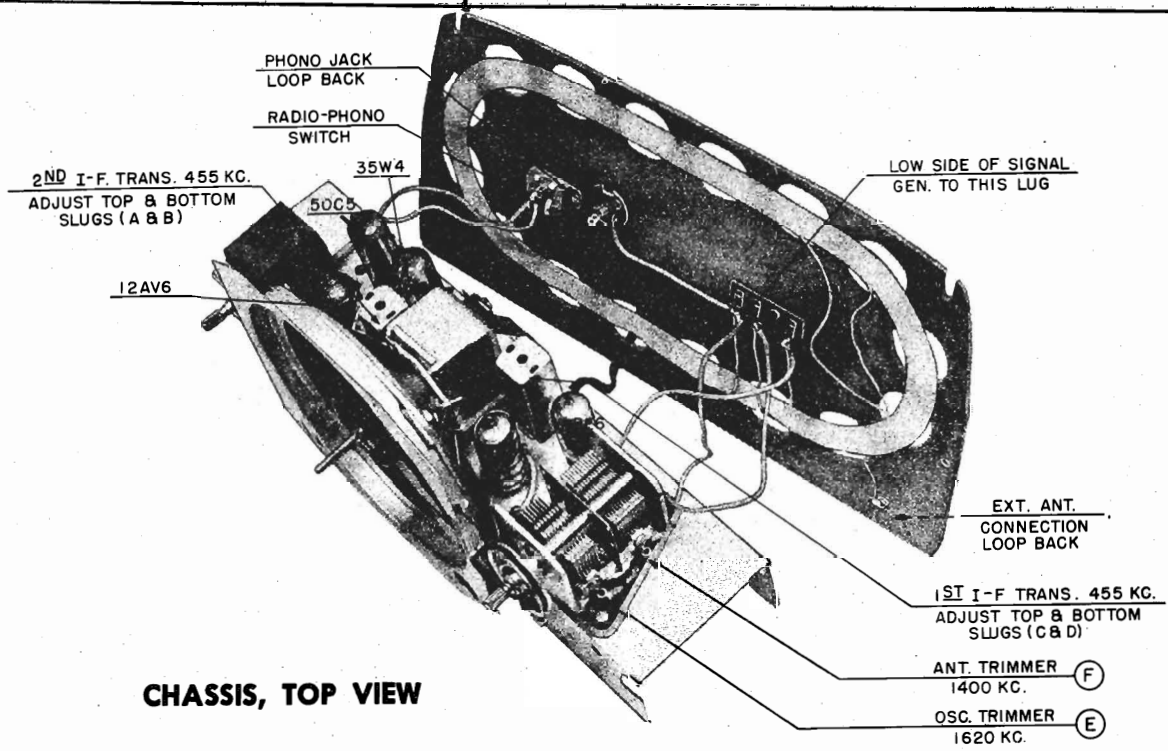

CHASSIS, TOP VIEW

MODELS E15BE, CE, SL, TN, WE,
E20GN, GY, MN, TN, Ch. 15-20E

PARTS LIST

Symbol No.	Part No.	Description	Symbol No.	Part No.	Description
C1A	151844	Capacitor, Variable		151773-4	Bridge (E20GY)
C1B		Capacitor, Variable } Two Section		151773-2	Bridge (E20TN)
C2	137727-109	Capacitor, 39 mmf., 10%, 200 v., ceramic		153567-1	Cabinet (E15WE)
C3	Part of T1	Capacitor, 106 mmf.		153567-2	Cabinet (E15BE)
C4	Part of T1	Capacitor, 131 mmf.		153567-3	Cabinet (E15TN)
C5	39001-85	Capacitor, .08 mfd., 600 v., paper		153567-4	Cabinet (E15SL)
C6	Part of T2	Capacitor, 131 mmf.		153567-5	Cabinet (E15CE)
C7	Part of T2	Capacitor, 106 mmf.		153007	Cabinet (E20MN)
C8A	144675-1	Capacitor, .0002 mfd., 500 v.		153008-3	Cabinet (E20GN)
C8B		Capacitor, .002 mfd., 500 v.		153008-4	Cabinet (E20GY)
C8C		Capacitor, .005 mfd., 500 v.		153008-2	Cabinet (E20TN)
C8D		Capacitor, .0002 mfd., 500 v.		139921	Clip, I.F. Transformer Mtg.
C9	143686-3	Capacitor, 100 mmf., 500 v., Molded disc ceramic		131154-1	Cotter (External), Pointer Pulley
C10	39001-85	Capacitor, .08 mfd., 600 v., paper		153291-1	Escutcheon, Dial (E15WE)
C11	39001-74	Capacitor, .002 mfd., 600 v., paper		153291-2	Escutcheon, Dial (E15BE, E15TN, E15SL, E15CE)
C12	142951-12	Capacitor-Resistor		151674-1	Escutcheon (E20MN)
C13	142951-11	Capacitor-Resistor		151674-3	Escutcheon (E20GN)
C14	39001-85	Capacitor, .08 mfd., 600 v., paper		151674-4	Escutcheon (E20GY)
C15	39001-17	Capacitor, .05 mfd., 600 v., paper		151674-2	Escutcheon (E20TN)
C16A	147174	Capacitor, 100 mfd., 150 v.		150423	Foot (Felt in metal cup)
C16B		Capacitor, 30 mfd., 150 v.		153862	Grille Assembly
C16C		Capacitor, 10 mfd., 150 v.		151627	Grille Cloth & Baffle Assy.
C17	39001-13	Capacitor, .01 mfd., 600 v., paper		153552-1	Knob (E15WE)
R1	39374-41	Resistor, 22,000 ohm, 10%, 1/2 w.		153552-2	Knob (E15BE)
R2	39374-69	Resistor, 2.2 megohm, 10%, 1/2 w.		153552-3	Knob (E15TN)
R3	39374-49	Resistor, 100,000 ohm, 10%, 1/2 w.		153552-4	Knob (E15SL)
R4	39374-34	Resistor, 5600 ohm, 10%, 1/2 w.		153552-5	Knob (E15CE)
R5	39374-85	Resistor, 10 megohm, 10%, 1/2 w.		152996-1	Knob (E20MN)
R6	151845	Control, Volume(3 megohm, Táp 300,000 ohm)		152996-3	Knob (E20GN)
R7	Part of C13	Resistor, 47,000 ohm, 1/2 w.		152996-4	Knob (E20GY)
R8	39374-57	Resistor, 470,000 ohm, 10%, 1/2 w.		152996-2	Knob (E20TN)
R9	39374-57	Resistor, 470,000 ohm, 10%, 1/2 w.		153540-2	Medallion (E15WE)
R10	39374-15	Resistor, 150 ohm, 10%, 1/2 w.		153540-3	Medallion (E15BE, E15TN, E15SL, E15CE)
R11	Part of C12	Resistor, 680,000 ohm, 1/2 w.		153289-1	Moulding, Trim (E15WE)
R12	39374-189	Resistor, 100 ohm, 10%, 2 w.		153289-2	Moulding, Trim (E15BE, E15TN, E15SL, E15CE)
R13	39374-114	Resistor, 1200 ohm, 10%, 1 w.		147275	Mounting, Rubber (2 used)
R14	39374-25	Resistor, 1000 ohm, 10%, 1/2 w.		45580-2	Mounting, Rubber (1 used)
R16	39374-1	Resistor, 10 ohm, 10%, 1/2 w.		94704-19	Nut (Push-On), Escutcheon
CA1	132300-1	Cable & Plug Assy., Power		153380-2	Pointer, Dial (E15BE, E15TN, E15SL, E15CE)
CO1	136998	Connector, Phono		153380-1	Pointer, Dial (E15WE)
L1	153571	Loop & Back Assy. (E15WE, E15BE, E15TN, E15SL, E15CE)		151854	Pointer, Dial (E20MN, E20GN, E20GY, E20TN)
L1	152994	Loop & Back Assy.,(E20MN, E20GN, E20GY, E20TN)		151946	Pulley, & Shaft Assy., Dial Pointer
L2	153405	Coil, Oscillator		39482-18CL	Screw, Bridge Mtg. (E15WE)
SP1	145956-2	Speaker (5-1/4" P.M.)		39178-29CL	Screw, Bridge Mtg. (E20MN, E20GN, E20GY, E20TN)
SW1	Part of R6	Switch, Power		39462-2	Socket, Tube
SW2	148260	Switch, Phono		51752	Spring, Drive Cord
T1	139919-3	Transformer, 1st I.F.		136630	Stud, Trimount (E20MN, E20GN, E20GY, E20TN)
T2	139919-3	Transformer, 2nd I.F.		153582	Stud, Trimount (E15WE, E15BE, E15TN, E15SL, E15CE)
T3	147171	Transformer, Output		147216	Suction Cup
TS1	147784	Shield, Tube (V2)		148775-2	Support & Bushing Assy., Pointer Pulley
TS2	147784	Shield, Tube (V3)			
	147934	Bottom, Chassis			
	153290-1	Bridge (E15WE)			
	153290-2	Bridge (E15BE, E15TN, E15SL, E15CE)			
	151773-1	Bridge (E20MN)			
	151773-3	Bridge (E20GN)			

MODELS E10BE, CE, RD,
WE, Ch. 10E, 10E-1

Model No.	Color
E10BE	Blue
E10CE	Chartreuse
E10RD	Red
E10WE	White

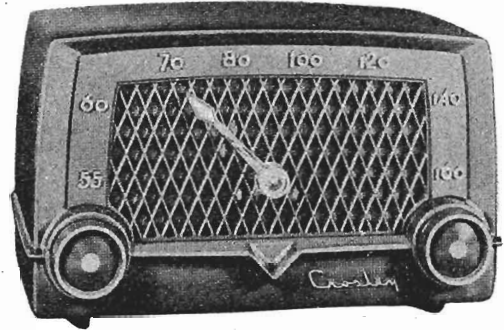

DESCRIPTION

TYPE: Five-tube, single band, Superheterodyne.
FREQUENCY RANGE: 540 to 1600 kc.
INTERMEDIATE FREQUENCY: 455 kc.
POWER SUPPLY: a.c.-d.c.
VOLTAGE RATING: 105-125 volts.
POWER CONSUMPTION: 30 watts maximum.
POWER OUTPUT: 1 watt maximum.

TUBE COMPLEMENT:

Type	Function
12BE6	Converter
12BA6	I. F. Amplifier
12AV6	Detector, AVC, 1st A. F. Amplifier
50C5	A. F. Power Output
35W4	Rectifier

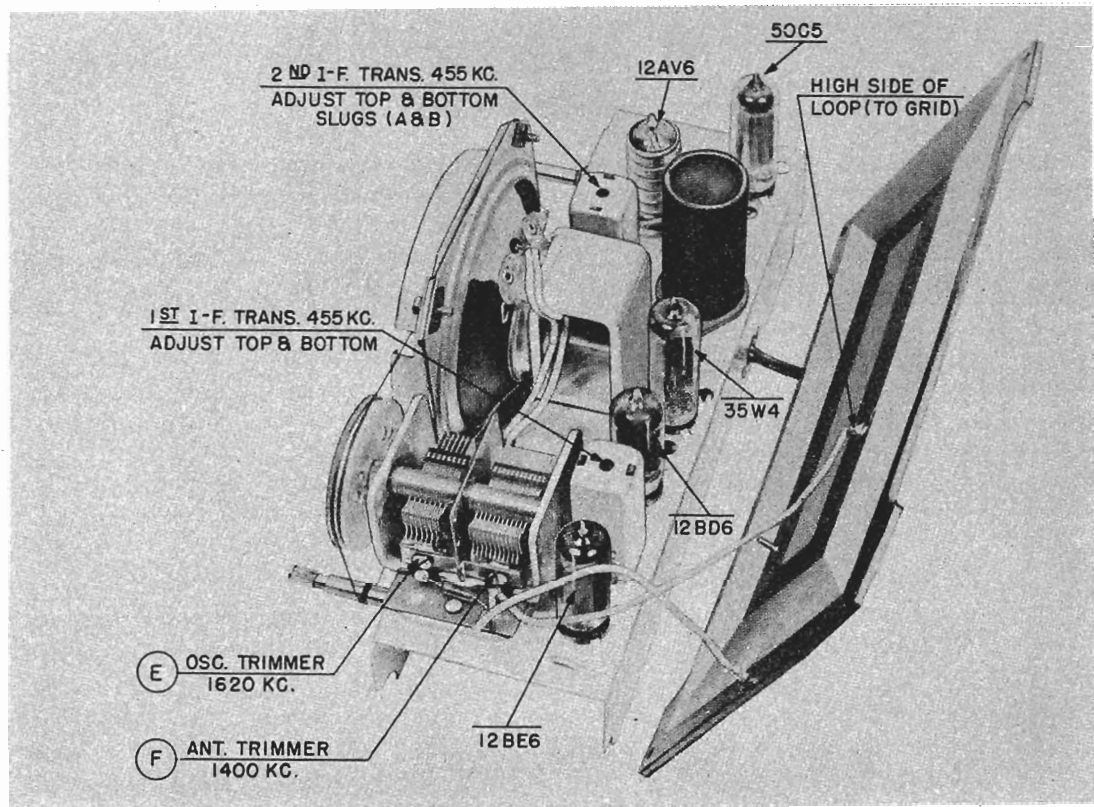

CHASSIS, TOP VIEW

**MODELS E10BE, CE, RD,
WE, Ch. 10E, 10E-1**

When using direct current it may be necessary to reverse the position of the power plug in the electric outlet for correct polarity.

Reversing the position of the power plug when alternating current is used may reduce hum.

Under no circumstances should a ground be connected to this receiver.

ALIGNMENT PROCEDURE

1. Connect an output meter across the speaker voice coil.
2. The r.f. signal input from the signal generator should be connected as indicated in the alignment chart. Connect the signal generator ground through a 0.1 mfd. condenser to B - (pin 2 on 12BA6 tube socket).
3. Turn the volume control on full and adjust the signal generator output to produce approximately midscale deflection of the output meter, but maintain signal generator output as low as possible to prevent AVC action in the receiver.

ALIGNMENT CHART

Alignment adjustment locations are shown on page 11, "CHASSIS, TOP VIEW."

Alignment Sequence	Signal Generator Output			Position of Dial pointer	Adjust for Maximum Output
	Frequency in KC	In Series with	To		
1	455	200 mmf.	High Side of Loop	1620	A, B, C & D (See Note 1.)
2	1620	Radiated to Loop		1620	E (See Note 2.)
3	1400	Radiated to Loop		Tune to Signal	F (See Note 2.)

ALIGNMENT NOTES

1. Repeat adjustments (A, B, C & D) in sequence, until maximum output is obtained.
2. Place signal generator output lead near the loop antenna. The loop antenna must be positioned with respect to the chassis to simulate its position when chassis and loop are fastened in cabinet.

MODELS E10BE, CE, RD,
WE, Ch. 10E, 10E-1

PARTS LIST

Symbol No.	Part No.	Description	Symbol No.	Part No.	Description
C1A	153497	Capacitor, Tuning & Pulley } Assembly	R12	39374-1	Resistor, 10 ohm, 1/2 w. (10E-1 chassis)
C1B		Capacitor, Tuning & Pulley } Assembly	CA1	142769-4	Cable & Plug Assembly, Power
C2	137727-109	Capacitor, 39 mmf., 10%, 200v., Ceramic	L1	153872	Loop & Back Assembly
C3	Part of T1	Capacitor, 106 mmf.	L2	153405	Coil, Oscillator
C4	Part of T1	Capacitor, 131 mmf.	SP1	148400-1	Speaker (4" PM), 10E chassis
C5	39001-85	Capacitor, .08 mfd., 600v., paper	SP2	135632	Speaker (4" EM), 10E-1 chassis
C6	Part of T2	Capacitor, 131 mmf.	TS1	147784-1	Shield, Tube (V5)
C7	Part of T2	Capacitor, 106 mmf.	SW1	39379-1	Switch, ON-OFF
C8A	151550-1	Capacitor, 220 mmf. } Assembly	T1	139919-3	Transformer, 1st I.F.
C8B		Capacitor, .002 mmf. } Assembly	T2	139919-3	Transformer, 2nd I.F.
C8C		Capacitor, 125 mmf. } Assembly	T3	138131-1	Transformer, Audio, Output
C8D		Capacitor, 5000 mmf. } Assembly		153866	Baffle & Grille Cloth Assembly
C8E		Capacitor, 125 mmf. } Assembly		153851	Bracket & Baffle Assembly, Pointer Shaft Bushing
C11	39001-80	Capacitor, .02 mfd., 600v., paper		153887-1	Cabinet, Model E-10WE
C12	39001-85	Capacitor, .08 mfd., 600v., paper		153887-2	Cabinet, Model E-10CE
C13	39477-45	Capacitor, .047 mfd. 600v., molded paper		153887-3	Cabinet, Model E-10RD
C14A	154280	Capacitor, 50 mfd., 150v., Electrolytic		153887-4	Cabinet, Model E-10BE
C14B		Capacitor, 30 mfd., 150v., (10E chassis)		131154-1	Cotter (External), Drive Shaft
C15A	151617	Capacitor, 20 mfd., 150v., Electrolytic		153855-1	Knob (2 used), Model E-10WE
C15B		Capacitor, 20 mfd., 150v., (10E-1 chassis)		153855-2	Knob (2 used), Model E-10CE
R1	39374-41	Resistor, 22,000 ohm, 10%, 1/2 w.		153855-3	Knob (2 used), Model E-10RD
R2	39374-1	Resistor, 10 ohm, 10%, 1/2 w.		153855-4	Knob (2 used), Model E-10BE
R3	39374-69	Resistor, 2.2 megohm, 10%, 1/2 w.		94704-7	Nut (Push on type), 4 used
R4	39374-45	Resistor, 47,000 ohm, 10%, 1/2 w.		153846	Pointer, Dial
R5A	Part of C8	Resistor, 6.8 megohm		153848	Pulley & Shaft Assembly, Dial Pointer
R5B	Part of C8	Resistor, 470,000 ohm } Assembly		153588-1	Shaft, Dial Cord Drive
R5C	Part of C8	Resistor, 470,000 ohm } Assembly		39462-2	Socket, Tube
R6	39378-13	Control, Volume (1 megohm, tapped 300,000 ohm)		51752	Spring, Drive Cord
R9	39374-15	Resistor, 150 ohm, 10%, 1/2 w.		132124	Stud (Trimount, 4 used), Back & Loop Assembly
R11	39374-26	Resistor, 1200 ohm, 10%, 1/2 w. (10E chassis)			

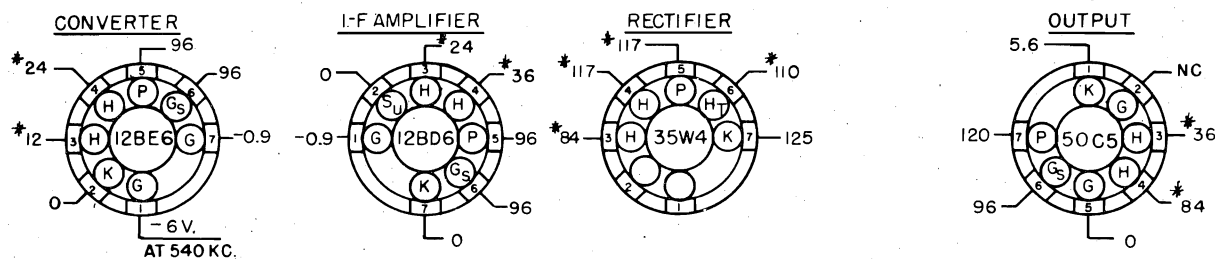

- NOTES.**
1. BOTTOM VIEW OF TUBE SOCKETS
 2. MEASURE VOLTAGE WITH AN ELECTRONIC VOLTMETER FROM SOCKET LUG TO B-PIN 2 ON THE 12BD6.
 3. LINE VOLTAGE 117 V. 60~
 4. NC = NO CONNECTION.
 5. * = AC VOLTAGE
 6. SOCKET VOLTAGE TOLERANCE ± 10%.

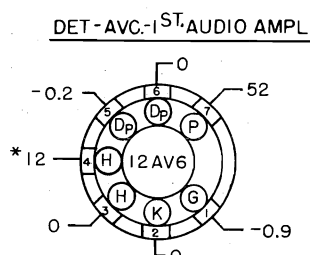

MODELS E-75CE, RD, GN, TN,
Ch. 75E; E-85CE, GN, RD, TN,
Ch. 85E

Chassis 75E

Models: E-75 CE, E-75 RD, E-75 GN, E-75-TN

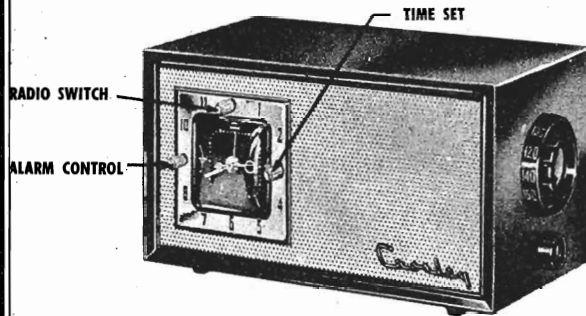

Chassis 85E

Models: E-85 CE, E-85 RD, E-85 GN, E-85 TN

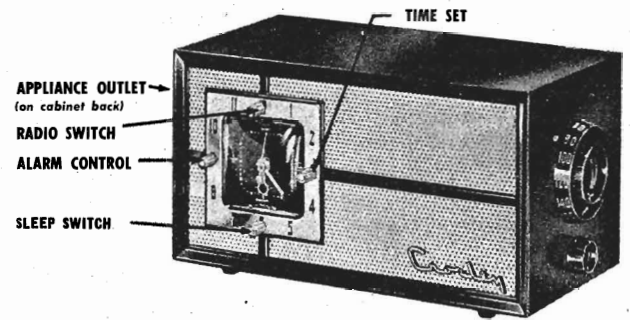

DESCRIPTION

TYPE: Five-tube, single band, Superheterodyne.

FREQUENT RANGE: 540 to 1600 kc.

INTERMEDIATE FREQUENCY: 455 kc.

POWER SUPPLY: 60 cycle, a.c. only.

VOLTAGE RATING: 105-125 volts.

POWER OUTPUT: 1 watt maximum.

POWER CONSUMPTION. 35 watts.

SLEEP SWITCH. Set it for up to 90 minutes operation of radio or appliance — turns them off automatically. (85E only.)

ELECTRIC CLOCK of highest accuracy. The jewel-like clock has a black face set off by hour and minute hands in blue, sweep-second hand in gold, and alarm set hand in red. Clock controls in sparkling clear plastic.

ALARM CONTROL. Set it for time radio (or appliance 85E only) is to turn on automatically.

RADIO SWITCH has three positions: "Off" to turn off radio; "Auto" to turn radio (or appliance 85E only) on automatically at pre-set time; "On" for manual radio operation.

APPLIANCE OUTLET is provided at rear of set for connecting any appliance (not exceeding 1100 watts) to be controlled by timing device. (85E only.)

TUBE COMPLEMENT:

Type	Function
12BE6	Converter
12BD6	I. F. Amplifier
12AT6	Detector, AVC, 1st. A. F. Amplifier
50C5	A. F. Power Output
35W4	Rectifier

TIME SET, for setting clock to time of day.

DRIFT-FREE TUNING, accomplished by Crosley's frequency stabilized oscillator, keeps receiver aligned precisely with station to which you have tuned.

EXCEPTIONALLY FINE TONE — the result of advanced engineering of the Crosley circuit and components.

INCREASED SENSITIVITY AND STABILITY. Permeability tuned (iron core) I.F. transformers give greater stability and sensitivity so that distant station can be received with minimum interference.

AUTOMATIC VOLUME CONTROL holds the volume as you set it.

BUILT-IN ANTENNA consists of a sturdy high-efficiency loop which receives stations sharply and clearly.

CHASSIS 75E, 85E

ALIGNMENT PROCEDURE

1. Connect an output meter across the speaker voice coil (3.2 ohms).
2. Feed an R.F. signal modulated 30% at 400 cycles to the high side of loop (inside winding of loop) as indicated in the alignment chart. Connect signal generator ground through a 0.1 mfd capacitor to B-.
3. Turn the Radio Switch (top knob on clock dial) to the "ON" position.
4. Turn the volume control to maximum clockwise position and adjust the signal generator output to produce approximately mid-scale deflection of the output meter, but maintain signal generator output as low as possible to prevent AVC action.

ALIGNMENT CHART

Alignment locations are shown on page 17.

Alignment Sequence	Signal Generator Output			Position of Tuning Gang	Adjust for Max. Output	Remarks
	Freq. in KC.	In Series With	To			
1	455	200 mmf.	Hi side of loop	Open	A&B	See note 1
2	455	200 mmf.	Hi side of loop	Open	C&D	See note 1
3 Repeat adjustments 1 and 2 until maximum output is obtained.						
4	1620	Radiated Signal	Loop	Open	E	See note 2
5	1400	Radiated Signal	Loop	Tune in Sig.	F	See note 2

Notes:

1. The speaker must be removed from the chassis in order to adjust the bottom slugs on the I.F. Transformers. **DO NOT REMOVE THE WIRES FROM THE SPEAKER.**
2. The signal can be radiated to the loop antenna by placing the output lead of the signal generator close to the loop.

For oscillator and antenna trimmer alignment, the loop antenna must be positioned with respect to the chassis to simulate position when chassis and loop are fastened in the cabinet so that no further adjustment of the antenna trimmer (F) will be necessary when the chassis and loop are mounted in the cabinet.

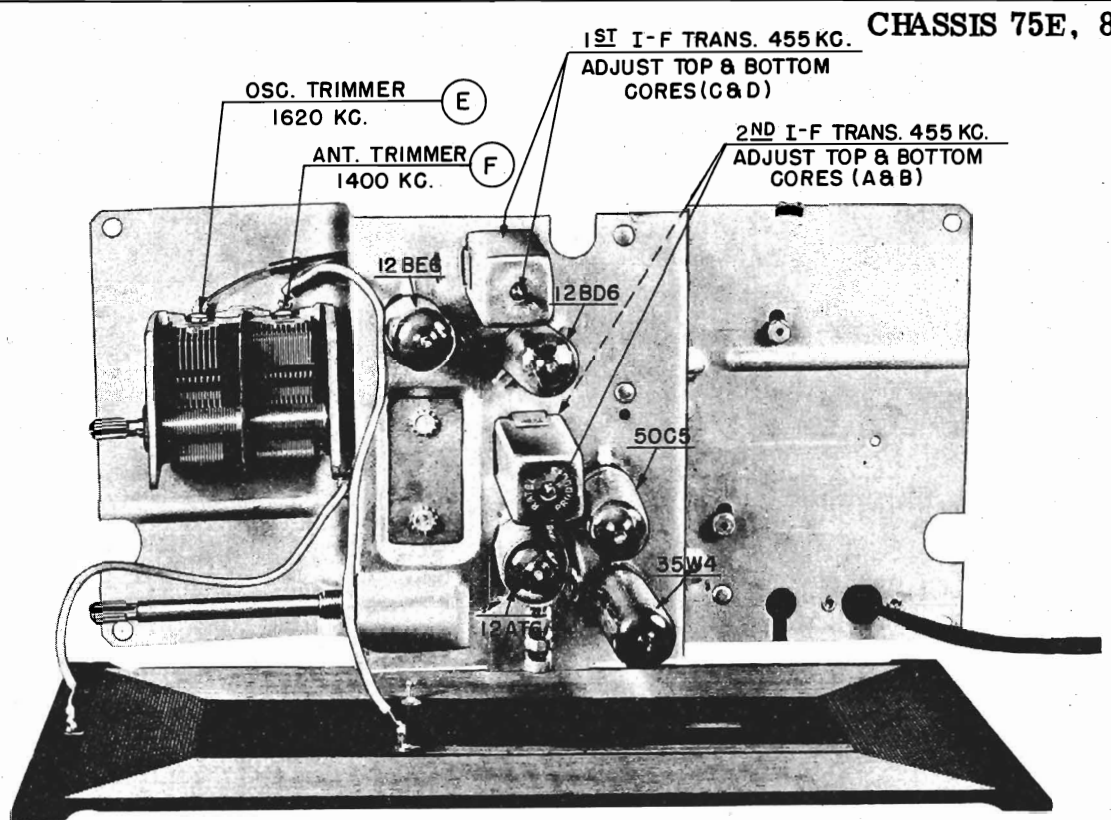

TOP VIEW - CHASSIS 75E

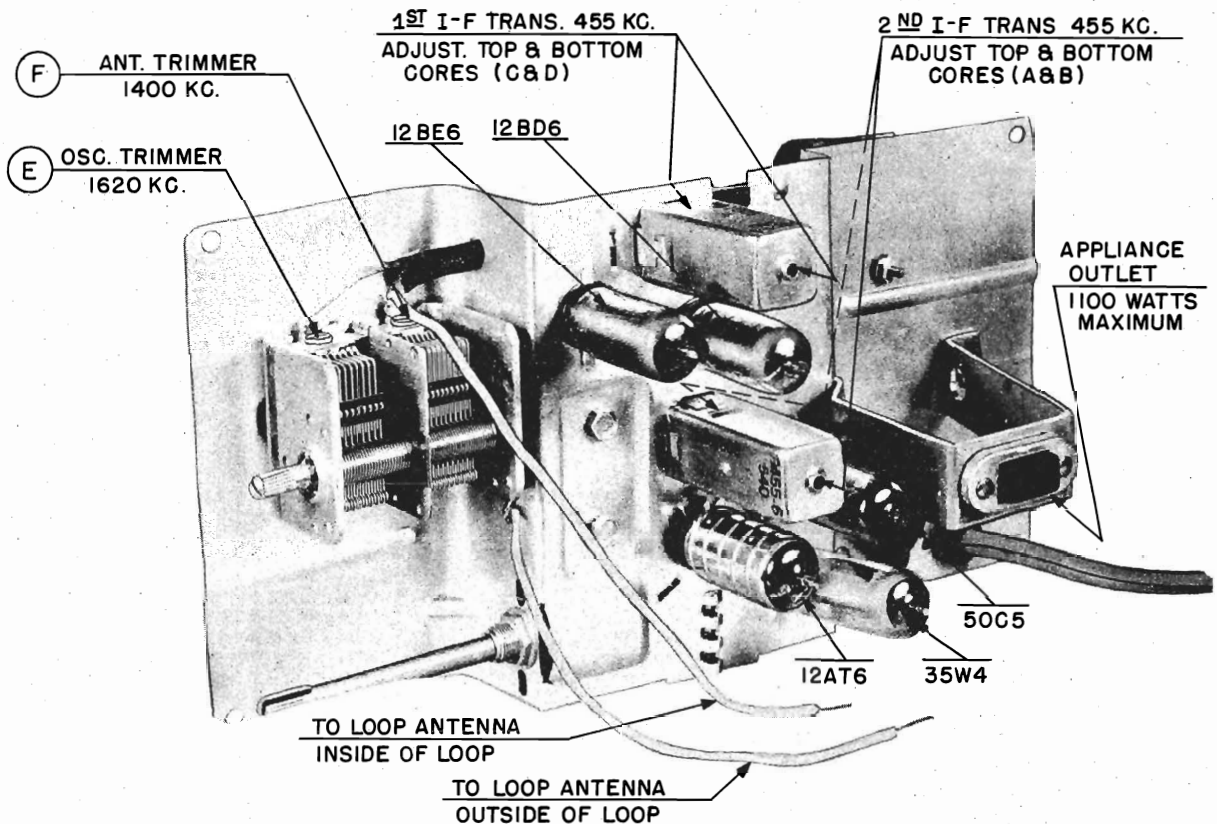

TOP VIEW - CHASSIS 85E

MODELS E-75CE, GN, RD, TN,
Ch. 75E; E-85CE, GN, RD, TN,
Ch. 85E

SOCKET VOLTAGE CHART

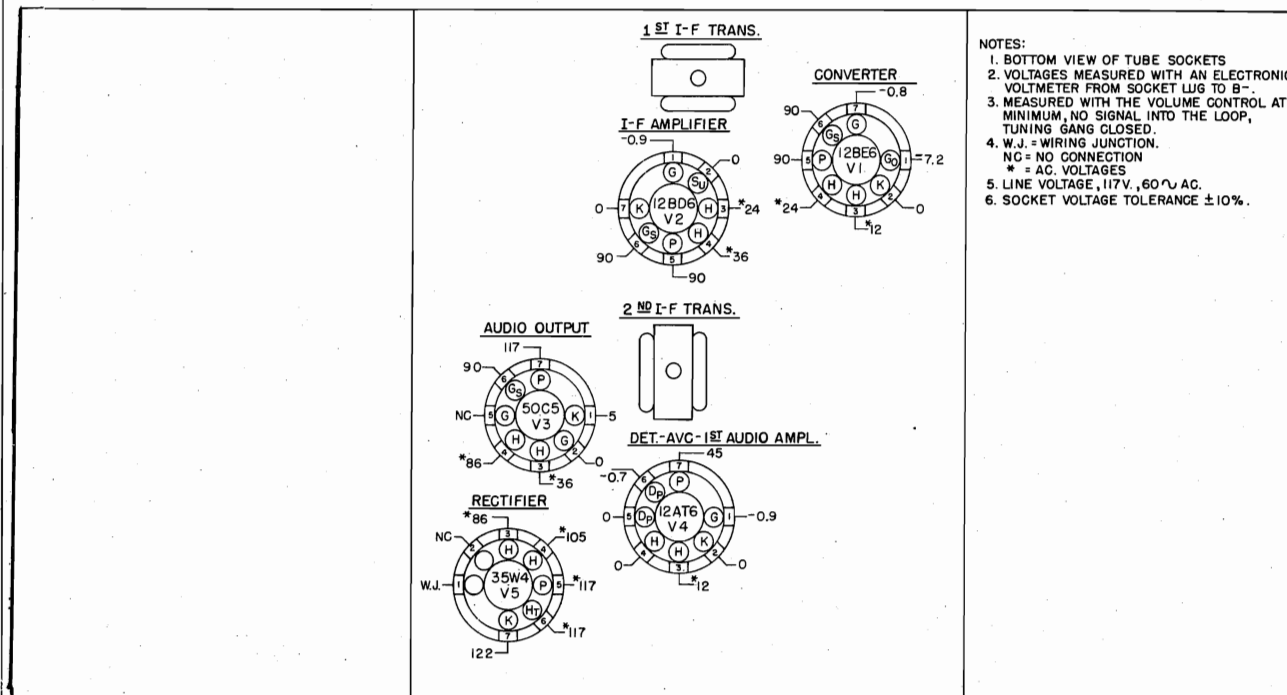

PARTS LIST

Symbol No.	Part No.	Description	Symbol No.	Part No.	Description
C1A	154962	Capacitor, Tuning } Assembly	L2	153405	Coil, Oscillator
C1B		Capacitor, Tuning } Assembly	SP1	138762-8	Speaker P.M. (4")
C2	137727-109	Capacitor, 39 MMF., 10%, 200 v., Ceramic	TS1	147784	Shield, Tube
C3	Part of T1	Capacitor	SW1	Part of CL1	Switch, ON-OFF, Power
C4	Part of T1	Capacitor	T1	155007-1	Transformer, 1st I.F.
C5	39477-46	Capacitor, .068 MFD., 600 v., Molded Paper	T2	155007-1	Transformer, 2nd I.F.
C6	Part of T2	Capacitor	T3	155015	Transformer, Audio Output
C7	Part of T2	Capacitor	CO1	155016	Appliance Outlet & Bracket Assembly (Chassis 85E only)
C8A	151550-1	Capacitor, 220 MMF. } Assembly	CL1	154971	Clock Assembly (Chassis 75E)
C8B		Capacitor, .002 MFD. } Assembly	CL1	155107	Clock Assembly (Chassis 85E)
C8C		Capacitor, 125 MMF. } Assembly	155214-1		Cabinet, Model E-75CE
C8D		Capacitor, .005 MFD. } Assembly	155214-2		Cabinet, Model E-75RD
C8E		Capacitor, 125 MMF. } Assembly	155214-3		Cabinet, Model E-75TN
C9	137727-8	Capacitor, 1000 MMF., 10%, 300v., Ceramic	155214-4		Cabinet, Model E-75GN
C11	39477-43	Capacitor, .002 MFD., 600v., Molded Paper	155214-5		Cabinet, Model E-85CE
C12	39477-45	Capacitor, .047 MFD., 600v., Molded Paper	155214-6		Cabinet, Model E-85RD
C13	39477-46	Capacitor, .068 MFD., 600v., Molded Paper	155214-7		Cabinet, Model E-85TN
C14A	155006	Capacitor, 50 MFD., 150v. } Electrolytic	155214-8		Cabinet, Model E-85GN
C14B		Capacitor, 30 MFD., 150v. } Electrolytic	155017-1		Grille, Model E-75CE
R1	39374-61	Resistor, 1 meg OHM, 10%, 1/2 w.	155017-2		Grille, Model E-75RD
R2	39374-41	Resistor, 22,000 OHM, 10%, 1/2 w.	155017-3		Grille, Model E-75TN
R3	39374-1	Resistor, 10 OHM, 10%, 1/2 w.	155017-4		Grille, Model E-75GN
R4	39374-69	Resistor, 2.2 Meg OHM, 10%, 1/2 w.	155021-1		Grille & Bar Assembly, Model E-85CE
R5	39374-45	Resistor, 47,000 OHM, 10%, 1/2 w.	155021-2		Grille & Bar Assembly, Model E-85RD
R6	154961	Control, Volume, 1 Meg OHM	155021-3		Grille & Bar Assembly, Model E-85TN
R7	39374-15	Resistor, 2.2 Meg OHM, 10%, 1/2 w.	155021-4		Grille & Bar Assembly, Model E-85GN
R8A	Part of C8	Resistor, 6.8 Meg OHM } Assembly	155061-1		Knob, Volume Control
R8B		Resistor, 470,000 OHM } Assembly	154062-1		Knob, Tuning
R8C		Resistor, 470,000 OHM } Assembly	155003		Name Plate, Crosley (Used on 75 models only)
R9	39374-114	Resistor, 1200 OHM, 10%, 1 w.	154347-3		Name Plate, Crosley (Used on 85 models only)
CA1	149780-3	Cable & Plug, Power (85E only)	39462-2		Socket, Tube (V1, V2, V3, V4, V5)
CA1	142769-5	Cable & Plug, Power (75E only)	132124		Stud (Trimount 3 used) Loop & Back Assembly
L1	154987	Loop Antenna & Back Assembly (75E only)	154963		Washer, Extruded (4 used), Clock Mounting
L1	155042	Loop Antenna & Back Assembly (85E only)			

D-155033-B

SCHEMATIC DIAGRAM

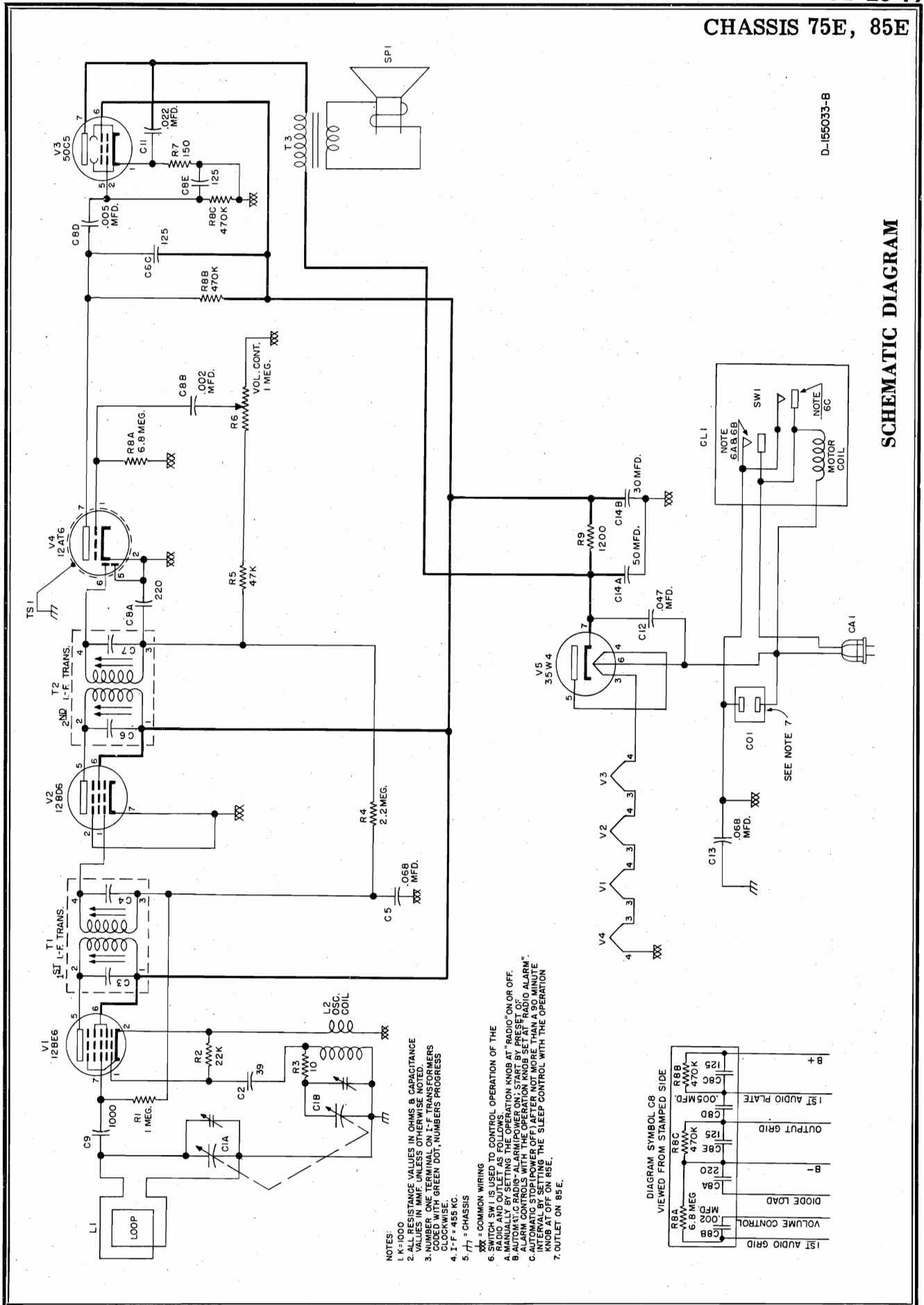

- NOTES:
1. K = 1000
 2. ALL RESISTANCE VALUES IN OHMS & CAPACITANCE VALUES IN MICROFARADS UNLESS OTHERWISE SPECIFIED.
 3. NUMBER ONE TERMINAL ON I-F TRANSFORMERS CODED WITH GREEN DOT, NUMBERS PROGRESS CLOCKWISE.
 4. I-F = 455 KC.
 5. --- = CHASSIS
 6. SWITCH SW 1 IS USED TO CONTROL OPERATION OF THE RADIO AND OUTLET AS FOLLOWS:
 A. AUTOMATIC RADIO-ALARM POWER ON; START BY PRESET OSC.
 B. AUTOMATIC RADIO-ALARM POWER OFF; STOP BY PRESET OSC.
 C. ALARM CONTROLS WITH THE OPERATION KNOB SET AT "RADIO ALARM".
 D. AUTOMATICALLY STOP POWER OFF AFTER NOT MORE THAN A 30 MINUTE INTERVAL.
 E. SLEEP CONTROL WITH THE OPERATION KNOB AT OFF ON RISE.
 F. OUTLET ON 85E.

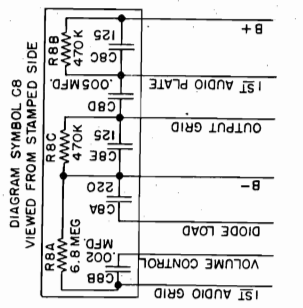

CHASSIS 75E, 85E

SUBJECT: TO ADD CLOCK REPLACEMENT PARTS TO CHASSIS 75E AND CHASSIS 85E PARTS LIST.

The following parts are now available for replacement on Clock Assemblies, part numbers 154971 and 155107.

PARTS LIST

Part No.	Description	Part No.	Description
156208-1	Dial Crystal (Plastic)	156208-8	Sleeve, Hand (Second)
156208-2	Bezel (Model E-75)	156208-9	Minute, Hand
156208-3	Knob (3 used on model E-75) (4 used on model E-85)	156208-10	Hour, Hand
156208-4	Timer Switch	156208-11	Indicator, Hand (Alarm)
156208-6	Adjusting Screw For Timer Switch	156208-13	Filler
156208-7	Bezel (Model E-85)	156208-14	Filler (Black)

A glass crystal is found on some of the above clock assemblies which were used in early production. Since the glass is not available, the following parts must be used for replacement.

Part No.	Description
156208-1	Dial Crystal, Plastic (1 used)
156208-13	Filler (3 used)
156208-14	Filler, Black (1 used)

The filler, 156208-14, with the black surface, should be placed next to the bezel, with the black surface facing the bezel. Figure 1 shows the assembly of these parts.

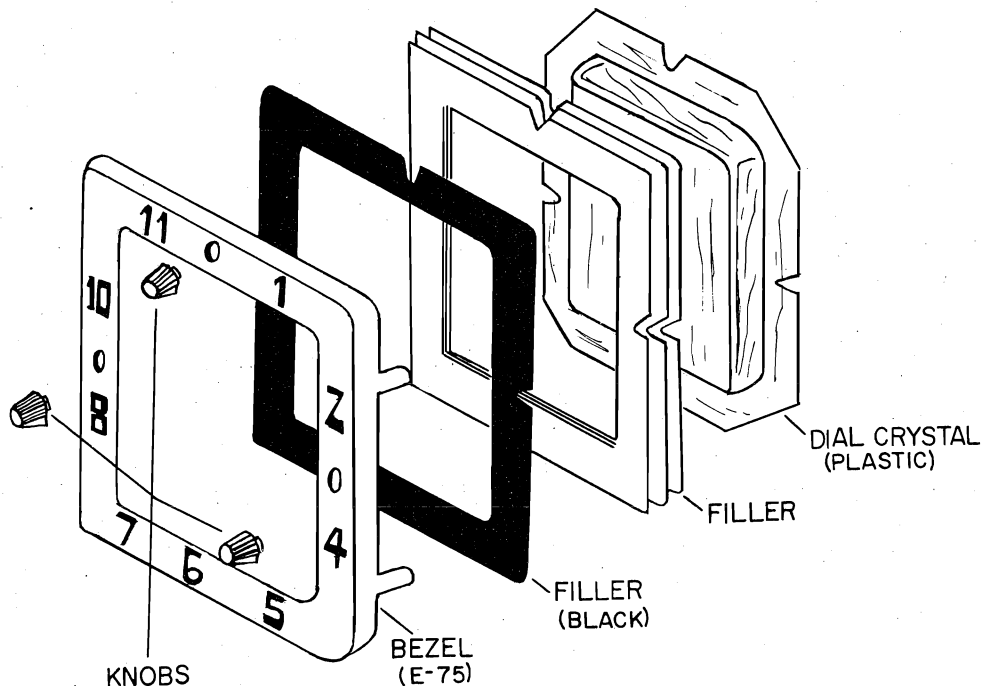
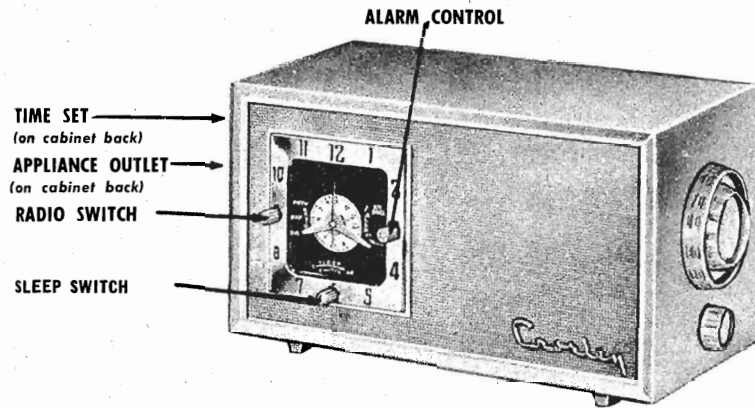

Figure 1

MODELS E-90BK, CE,
GY, RD, WE, Ch. 90E

CHASSIS 90E

Models: E-90WE, E-90CE, E-90GY, E-90RD, E-90BK



DESCRIPTION

TYPE: Five-tube, single band, Superheterodyne.

FREQUENCY RANGE: 540 to 1600 kc.

INTERMEDIATE FREQUENCY: 455 kc.

POWER SUPPLY: 60 cycle, a.c. only.

VOLTAGE RATING: 105-125 volts.

POWER OUTPUT: 1 watt maximum.

POWER CONSUMPTION:

Radio and Clock.....	35 watts
Clock	2 watts

TUBE COMPLEMENT:

Type	Function
12BE6	Converter
12BD6	I. F. Amplifier
12AT6	Detector, AVC, 1st. A. F. Amplifier
50C5	A. F. Power Output
35W4	Rectifier

SLEEP SWITCH — Set it up to 60 minutes operation of radio or appliance — turns them off automatically.

ELECTRIC CLOCK of highest accuracy. Framed in gold-color, the jewel-like clock has a black face set off by hour and minute hands in blue and sweep second hand in gold. Clock controls in clear plastic.

RADIO SWITCH has three positions: "Off" to turn off radio; "Auto" to turn radio or appliance on automatically; "On" for manual radio operation.

APPLIANCE OUTLET is provided at rear of set for connecting any appliance (not exceeding 1100 watts) to be controlled by timing device.

TIME SET, for setting clock to time of day.

ALARM CONTROL — Set it for time radio or appliance is to turn on automatically. Pull out

to have buzzer sound a few minutes after radio turns on.

DRIFT-FREE TUNING, accomplished by Crosley frequency stabilized oscillator, keeps receiver aligned precisely with station to which you have tuned.

EXCEPTIONALLY FINE TONE — The result of advanced engineering of the Crosley circuit and components.

INCREASED SENSITIVITY AND STABILITY. Permeability tuned (iron core) IF transformers give greater stability and sensitivity so that distant stations can be received with minimum interference.

AUTOMATIC VOLUME CONTROL holds the volume as you set it.

BUILT-IN ANTENNA consists of a sturdy high-efficiency loop which receives stations sharply and clearly.

MODELS E-90BK, CE, GY, RD, WE, Ch. 90E

Under no circumstances should a ground be connected to this receiver.

ALIGNMENT PROCEDURE

1. Connect an output meter across the speaker voice coil (3.2 ohms).
2. Feed an R-F signal modulated 30% at 400 cycles to the high side of loop (inside winding of loop) as indicated in the alignment chart. Connect signal generator ground through a 0.1 mfd capacitor to B-.
3. Turn the Radio Switch to the "ON" position.
4. Turn the Volume Control to maximum clockwise position and adjust the signal generator output to produce approximately mid-scale deflection of the output meter, but maintain signal generator output as low as possible to prevent AVC action.

ALIGNMENT CHART

Alignment locations shown on page 23,

Alignment Sequence	Signal Generator Output			Position of Tuning Gang	Adjust for Max. Output	Remarks
	Freq. in KC.	In Series With	To			
1	455	200 mmf.	Hi side of loop	Open	A & B	See note 1
2	455	200 mmf.	Hi side of loop	Open	C & D	See note 1
3 Repeat steps 1 and 2 until maximum output is obtained						
4	1620	Radiated Sig.	Loop	Open	E	See note 2
5	1400	Radiated Sig.	Loop	Tune in Signal	F	See note 2

Notes:

1. The speaker must be removed from the chassis in order to adjust the bottom slugs on the I-F Transformers. **DO NOT REMOVE THE WIRES FROM THE SPEAKER.**
2. The signal can be radiated to the loop antenna by placing the output lead of the signal generator close to the loop. For oscillator and antenna trimmer alignment, the loop antenna must be positioned with respect to the chassis to simulate position when chassis and loop are fastened in the cabinet so that no further adjustment of the antenna trimmer (F) will be necessary when the chassis and loop are mounted in the cabinet.

SOCKET VOLTAGE CHART

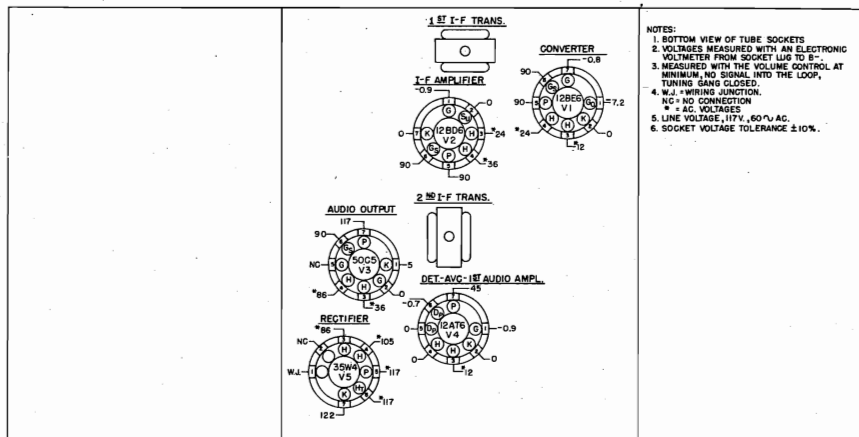

MODELS E-90BK, CE,
GY, RD, WE, Ch. 90E

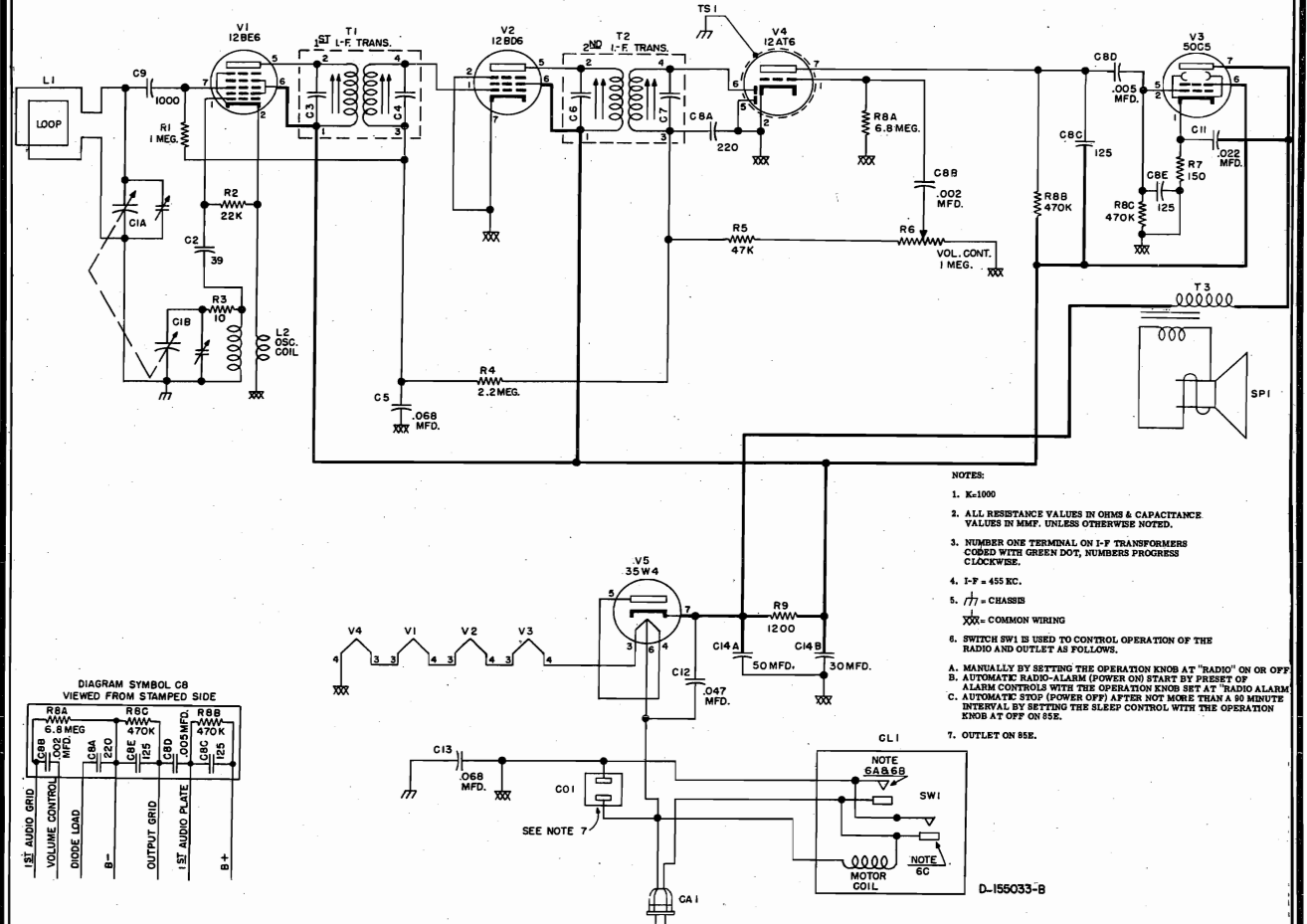

SCHEMATIC DIAGRAM

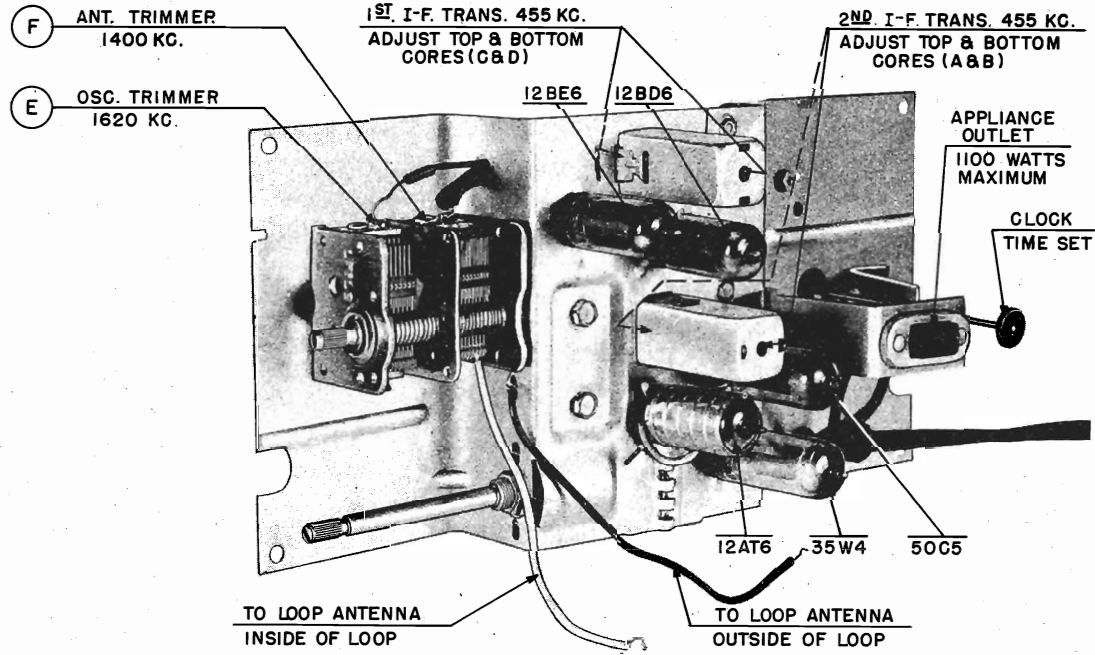

CHASSIS - TOP VIEW

MODELS E-90BK, CE,
GY, RD, WE, Ch. 90E

CLOCK ADJUSTMENTS

Procedure for checking timer switch and vibrator:

1. With the time set knob, turn the clock hands so as to advance the time at least one (1) hour. (For ease in checking, it is recommended that the time be set to the hour.)
2. Attach test light to switch leads.
3. Turn switch knob to "ON" position - light must go on.
4. Turn switch knob to "OFF" position - light must go out.
5. Set alarm disc so that small pointer on hour hand reads two (2) hours in advance of the time of the clock. **EXAMPLE:** If the clock hands are set to read 7 o'clock, set the alarm disc to read 9 o'clock.
6. Turn sleep switch to "60" - test light must go on.
7. Turn time set knob advancing clock hands to next hour - light must go out and SLEEP SWITCH SECTOR GEAR must be completely disengaged within one (1) hour plus or minus eight (8) minutes.
8. Manually push SLEEP SWITCH SECTOR GEAR in until it touches its mating pinion WITHOUT meshing - light must go on.
9. Turn switch knob to "AUTO" position.
10. Turn time set knob to advance clock hands so they read 15 minutes until the next hour. Then slowly advance the hands until the test light lights, which indicates the contacts are closed. The contacts must close somewhere between 14 minutes to the hour and 4 minutes past the hour.
11. Remove test light and connect 110 volt supply to the motor terminals.
12. Turn time set knob to advance the clock hands 4 minutes - vibrator must NOT buzz. Then advance the hands 14 minutes - vibrator MUST buzz within this 14 minute period.

Adjusting Contacts

1. Set the switch to "AUTO" position so that the SWITCH CAM FOLLOWER rests on the TIMING CAM. Contacts shall be adjusted at .020" minimum gap.
2. With switch in "OFF" position contacts shall remain open as in step one and there shall be clearance between SWITCH CAM FOLLOWER and TIMING CAM.
3. With switch in "ON" position, contacts shall be closed. Check for proper contact pressure by depressing LOWER CONTACT strip, using a small pointed tool. If UPPER CONTACT strip follows the LOWER CONTACT strip, a noticeable amount before the contacts separate, the pressure is sufficient.
4. Set the switch to "AUTO" position; pull out and turn alarm set knob counter-clockwise until the SWITCH CAM FOLLOWER drops into the slot of TIMING CAM. The contacts shall be closed. Check contact pressure as previously described in step three.
5. SWITCH ARM should clear CAM by .008" minimum when in the "AUTO" position.

Timing

1. Adjust timer for contact closure at 6:55 o'clock. On repeat tests, contacts shall close at 6:55 plus or minus 3 minutes. At all other settings the contacts shall close between 12 minutes before and 2 minutes after the setting time.
2. Check time keeping for a minimum of twelve hours with power applied to the motor. Clock must be run with vibrator (buzzer) shut off.

MODELS E-90BK, CE,
GY, RD, WE, Ch. 90E

Vibrator Adjustment:

1. Vibrator shall start buzzing 10 minutes plus or minus 5 minutes after contact closure occurs.
2. When the alarm set knob is pushed in ("shut-off" position of vibrator) the shut-off spring shall lift the vibrator sufficiently above the cam, so that the cam will not contact the vibrator in any position.
3. Adjust vibrator for good sounding position.
4. Vibrator shall be manually shut off before completion of buzzing period.

CLOCK LUBRICATION

1. Center stack bearing in base plate and hole in back gear pinion should be lubricated with Nye watch oil or equivalent.
2. Path of switch locating spring on bracket should be lubricated with Dixon graphite grease.

Symbol No.	Part No.	Description	Symbol No.	Part No.	Description
C1A	154962	Capacitor, Tuning } Assembly	L1	155042	Loop Antenna & Back Assembly
C1B		Capacitor, Tuning }	L2	153405	Oscillator Coil
C2	137727-109	Capacitor, 39 mmf., 10%, 200 V., Ceramic	SP1	138762-8	Speaker 4 inch (P.M.)
C3	Part of T1	Capacitor	TS1	147784	Shield Tube
C4	Part of T1	Capacitor	SW1	Part of CL1	Switch, ON - OFF, Power
C5	39477-46	Capacitor, .68 mfd., 600 V., Molded Paper	T1	155007-1	Transformer, 1st IF
C6	Part of T2	Capacitor	T2	155007-1	Transformer, 2nd IF
C7	Part of T2	Capacitor	T3	155015	Transformer, Audio Output
C8A	151550-1	Capacitor, 220 mmf. }	CO1	155016-2	Bracket & Appliance Outlet, Assembly
C8B		Capacitor, .002 mfd. }	CL1	155631	Clock Assembly
C8C		Capacitor, 125 mmf. } Assembly		155214-9	Cabinet, Model E-90 CE
C8D		Capacitor, .005 mfd. }		155214-10	Cabinet, Model E-90 RD
C8E		Capacitor, 125 mmf. }		155214-11	Cabinet, Model E-90 GY
C9	137727-8	Capacitor, 1000 mmf., 10%, 300 V., Ceramic		155214-12	Cabinet, Model E-90 WE
C11	39477-43	Capacitor, .022 mfd., 600 V., Molded Paper		155214-13	Cabinet, Model E-90 BK
C12	39477-45	Capacitor, .047 mfd., 600 V., Molded Paper		155022	Gasket, Grille
C13	39477-46	Capacitor, .068 mfd., 600 V., Molded Paper		155074	Grille, Metal
C14A	155006	Capacitor, 50 mfd., 150 V. } Electrolytic		155061-1	Knob, Volume Control, Model E-90 BK
C14B		Capacitor, 30 mfd., 150 V. }		155061-2	Knob, Volume Control, Model E-90 GY
C15	143686-1	Capacitor, 50 mmf., 500 V., Ceramic		155061-3	Knob, Volume Control, Model E-90 WE
R1	39374-61	Resistor, 1 Megohm, 10%, 1/2 W.		155061-4	Knob, Volume Control, Model E-90 RD
R2	39374-41	Resistor, 22,000 ohm, 10%, 1/2 W.		155061-5	Knob, Volume Control, Model E-90 CE
R3	39374-1	Resistor, 10 ohm, 10%, 1/2 W.		154062-1	Knob, Tuning, Model E-90 BK
R4	39374-69	Resistor, 2.2 Megohm, 10%, 1/2 W.		154062-2	Knob, Tuning, Model E-90 GY
R5	39374-45	Resistor, 47,000 ohm, 10%, 1/2 W.		154062-3	Knob, Tuning, Model E-90 WE
R6	154961	Control, Volume, 1 megohm		154062-4	Knob, Tuning, Model E-90 RD
R7	39374-15	Resistor, 150 ohm, 10%, 1/2 W.		154062-5	Knob, Tuning, Model E-90 CE
R8A	Part of C8	Resistor, 6.8 megohm }		155003	Name Plate (Crosley), Model E-90 BK
R8B		Resistor, 470,000 ohm } Assembly		155347-3	Name Plate (Crosley), Models E-90 GY
R8C		Resistor, 470,000 ohm }		39462-2	E-90 WE, E-90 RD, & E-90 CE
R9	39374-114	Resistor, 1200 ohm, 10%, 1 W.		132124Stud (Trimount 3 Used), Loop & Back Assembly	
R10	39374-9	Resistor, 47 ohm, 10% 1/2 W.		154963Washer, Extruded (4 Used), Clock Mounting	
CA1	149780-3	Cable & Plug, Power			

CLOCK REPLACEMENT PARTS

Part No.	Description	Part No.	Description
151389-15	Alarm Dial	151389-19	Knob, Radio Switch
151389-11	Bezel	151389-19	Knob, Sleep Switch
151389-12	Bezel Color Ring	151389-8	Knob, Time Set
151389-13	Crystal	151389-10	Rotor Unit (60 cycle)
151389-14	Dial, Black		
151389-9	Field & Coil (60 cycle)		
151389-16	Hands, Hour & Minute		
151389-17	Hand, Sweep Second		
151389-18	Knob, Alarm Set		

MODELS F-100BE, BK,
CE, GN, RD, Ch. 100F

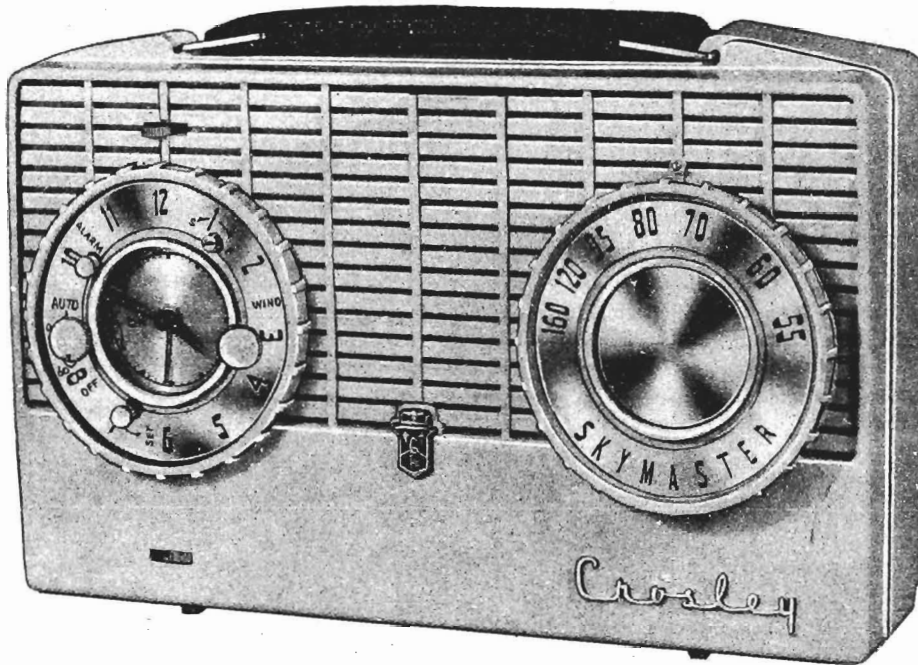

DESCRIPTION

The above models are four-tube superheterodyne, battery portable radio receivers combined with a spring wound clock timer that can be set to automatically turn the radio on or off. The receiver is designed for reception of Standard Broadcast (AM) stations with frequencies between 540 and 1600 kilocycles.

The receiver uses long-life "A" batteries, with provision made to use standard flash-light batteries ("D" cells) in localities where the long-life batteries are not available, with a resultant decrease in "A" battery life.

TYPE: Four-tube, single band Superheterodyne.

FREQUENCY RANGE: 540 to 1600Kc.

INTERMEDIATE FREQUENCY: 455 Kc.

MAXIMUM POWER OUTPUT: 170 Milliwatts.

"A" BATTERY: Two 1½ Volt Eveready #964.

"B" BATTERY: One 75 Volt Eveready #437.

NOTE: Complete Battery Kit No. EV-1
(Crosley Part No. 156292)

Consists of { Two 1½ volt "A" Batteries # 964.
One 75 volt "B" Battery #437.

Available at your Crosley Distributor.

TUBE COMPLEMENT:

Type	Function
1U5	Detector — AVC — 1st Audio Amplifier
1R5	Converter
3V4	Audio Output
1U4	IF Amplifier

SOCKET VOLTAGE CHART

- NOTES:
 1. BOTTOM VIEW OF TUBE SOCKETS.
 2. VOLTAGES MEASURED WITH AN ELECTRONIC VOLTMETER FROM SOCKET LUG TO CHASSIS.
 3. BATTERY SUPPLY VOLTAGES "A" BATTERY 15V. "B" BATTERY 75V.
 4. BATTERY SWITCH IN "MAX. POWER OUTPUT" POSITION. "OUTDOOR INDOOR" SWITCH IN "OUTDOOR" POSITION.
 5. N.C. = NO CONNECTION, W.J. = WIRE JUNCTION.
 6. SOCKET VOLTAGE TOLERANCE $\pm 10\%$.

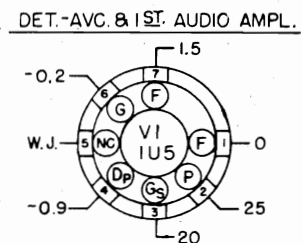
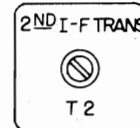
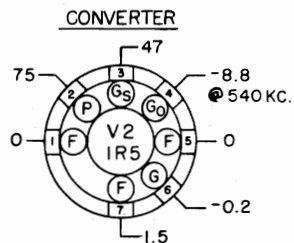
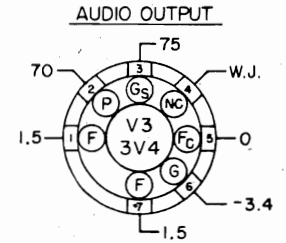
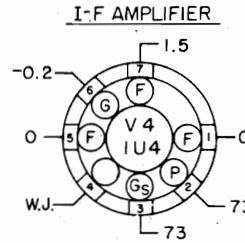
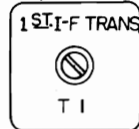

REMOVING THE CHASSIS

- Slip the tuning knob from the shaft of the tuning gang, and pull the knobs from the clock.
- Open the cabinet back by lifting up on the handle and pushing down and out with the thumb on the top edge of the cabinet back; then remove the back.
- Remove the "A" and "B" batteries.
- Remove the chassis (Chassis is fastened to the front of the cabinet by five cross recess screws)

ALIGNMENT PROCEDURE

- Connect an output meter across the speaker voice coil (3.2 ohms).
- Connect "A" and "B" batteries to the receiver.
- Turn the "TIMER SWITCH" to the on position.
- Apply an R-F signal, modulated 30% at 400 cycles to the receiver as indicated in the alignment chart. Connect the signal generator ground lead to chassis.
- Turn the volume control to maximum, set the POWER SAVER SWITCH for maximum power output and the INDOOR-OUTDOOR SWITCH to the Outdoor position.
- Adjust the signal generator to produce mid-scale deflection on the output meter, but maintain output as low as possible to prevent AVC action.

ALIGNMENT CHART

ALIGNMENT SEQUENCE	SIGNAL GENERATOR			POSITION OF TUNING GANG	ADJUST FOR MAX. OUTPUT	REMARKS
	FREQ. IN KC.	SIGNAL	TO			
1.	455	in series with .05MFD	Mixer Grid	OPEN	A & B	
2.	455	in series with .05MFD	Mixer Grid	OPEN	C & D	
3. Repeat steps 1 and 2 until maximum output is obtained.						
4.	1620	Radiated	Built-in Antenna	OPEN	E	See Note 1
5.	1400	Radiated	Built-in Antenna	Tune-in sig.	F	See Note 1 & 2

NOTES:

- The signal can be radiated to the built-in antenna by placing the output lead of the signal generator close to the antenna.
- Replace the chassis in the cabinet by reversing the order of the removal procedure listed above.

MODELS F-100BE, BK,
CE, GN, RD, Ch. 100F

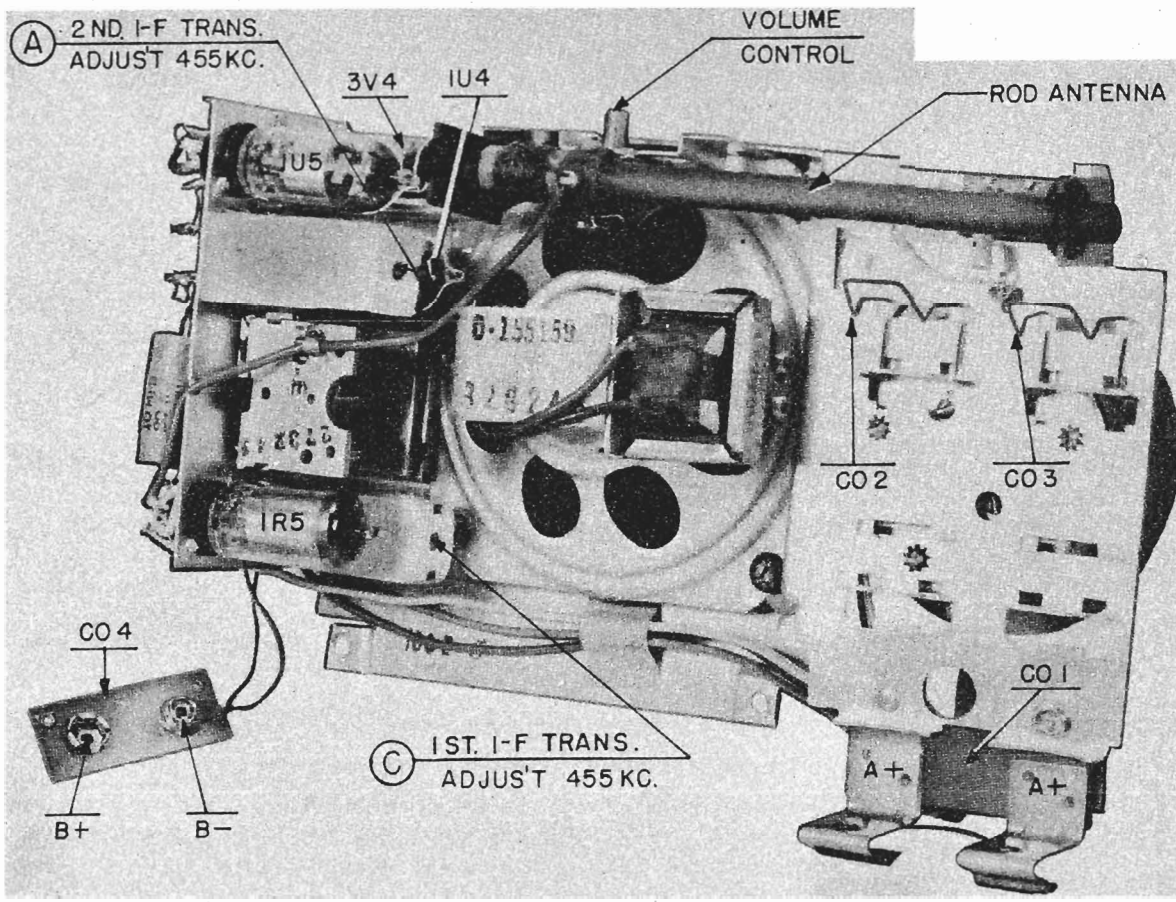

CHASSIS, REAR VIEW

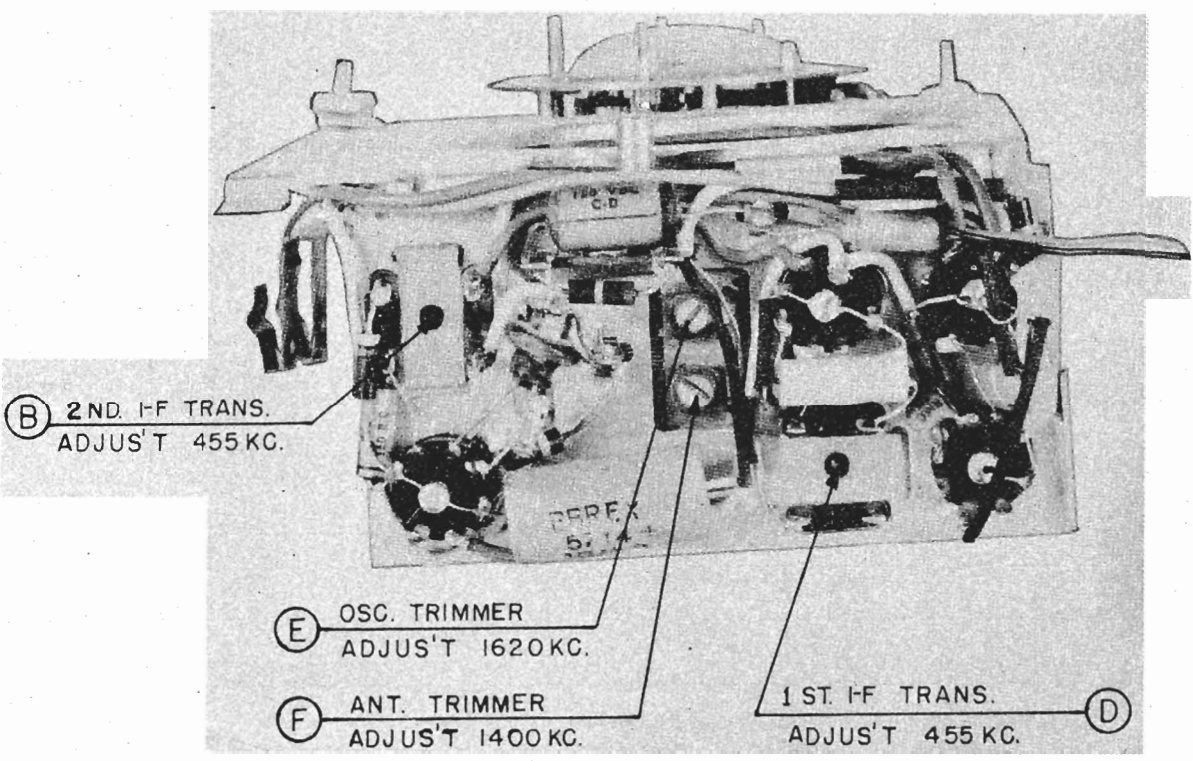

CHASSIS, BOTTOM VIEW

MODELS F-100BE, BK, CE, GN, RD, Ch. 100F

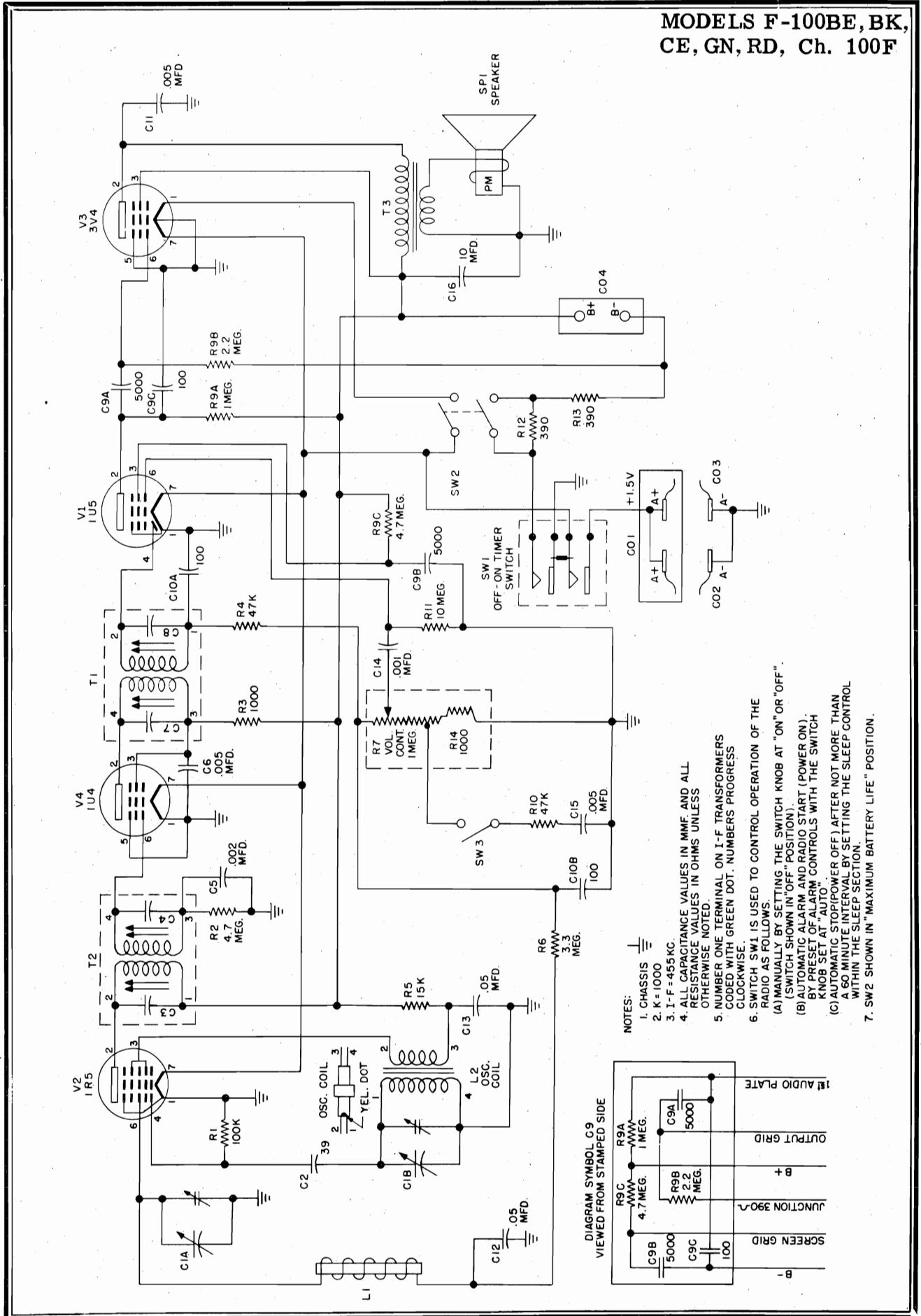

- NOTES:
1. CHASSIS
 2. K = 1000
 3. I-F = 455 KC.
 4. ALL CAPACITANCE VALUES IN MMF. AND ALL RESISTANCE VALUES IN OHMS UNLESS OTHERWISE NOTED.
 5. NUMBER ONE TERMINAL ON I-F TRANSFORMERS CODED WITH GREEN DOT. NUMBERS PROGRESS CLOCKWISE.
 6. SWITCH SW1 IS USED TO CONTROL OPERATION OF THE RADIO AS FOLLOWS:
 (A) MANUALLY BY SETTING THE SWITCH KNOB AT "ON" OR "OFF".
 (B) AUTOMATIC ALARM AND RADIO START (POWER ON).
 (C) AUTOMATIC STOP (POWER OFF) AFTER NOT MORE THAN 15 MINUTES BY SETTING THE SLEEP CONTROL KNOB SET AT "AUTO".
 (D) AUTOMATIC STOP (POWER OFF) AFTER NOT MORE THAN 15 MINUTES BY SETTING THE SLEEP CONTROL KNOB IN THE "SLEEP" POSITION.
 7. SW2 SHOWN IN "MAXIMUM BATTERY LIFE" POSITION.

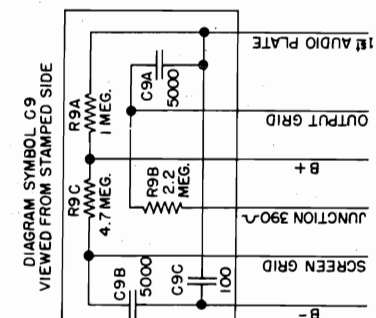

CHASSIS 100F

Symbol No.	Part No.	Description	Symbol No.	Part No.	Description
C1A	155290	Capacitor, Tuning } Assembly		155254-4	Button, "Indoor - Outdoor Switch", Model F-100BK
C1B		Capacitor, Tuning }		155254-5	Button, "Max. Battery Life Switch", Model F-100GN
C2	137727-109	Capacitor, 39 mmf., 10%, 200V., ceramic		155254-6	Button, "Indoor - Outdoor Switch", Model F-100GN
C3	Part of T 1	Capacitor		155254-7	Button, "Max. Battery Life Switch", Model F-100RD
C4	Part of T 1	Capacitor		155254-8	Button, "Indoor - Outdoor Switch", Model F-100RD
C5	39433-10	Capacitor, .002 mfd., 150., paper		155254-9	Button, "Max. Battery Life Switch", Model F-100CE
C6	144675-2	Capacitor, .005 mfd., 500V., disc ceramic		155254-10	Button, "Indoor - Outdoor Switch", Model F-100CE
C7	Part of T 2	Capacitor		155248-1	Cabinet Assembly, Model F-100BE
C8	Part of T 2	Capacitor		155248-2	Cabinet Assembly, Model F-100BK
C9A	151550-3	Capacitor, 5000 mmf., 450V. }		155248-3	Cabinet Assembly, Model F-100GN
C9B		Capacitor, 5000 mmf., 450V. } Assem-		155248-4	Cabinet Assembly, Model F-100RD
C9C		Capacitor, 100 mmf., 450V. } bly		155248-5	Cabinet Assembly, Model F-100CE
C10A	142951-2	Capacitor, 100 mmf., 500V. }		155239-1	Cabinet, Back, Model F-100BE
C10B		Capacitor, 100 mmf., 500V. } bly		155239-2	Cabinet, Back, Model F-100BK
C11	39433-11	Capacitor, .005 mfd., 150V., paper		155239-3	Cabinet, Back, Model F-100GN
C12	39433-14	Capacitor, .05 mfd., 150V., paper		155239-4	Cabinet, Back, Model F-100RD
C13	39433-14	Capacitor, .05 mfd., 150V., paper		155239-5	Cabinet, Back, Model F-100CE
C14	144675-28	Capacitor, .001 mfd., 500V., disc ceramic		155238-1	Cabinet, Front, Model F-100BE
C15	137727-121	Capacitor, .005 mfd., 10%, 500V. ceramic		155238-2	Cabinet, Front, Model F-100BK
C16	155355	Capacitor, 10 mfd., 80V., Electrolytic		155238-3	Cabinet, Front, Model F-100GN
R1	39374-49	Resistor, 100,000 ohm, 10%, 1/2W.		155238-4	Cabinet, Front, Model F-100RD
R2	39374-77	Resistor, 4.7 megohm, 10%, 1/2W.		155238-5	Cabinet, Front, Model F-100CE
R3	39374-25	Resistor, 1000 ohm, 10%, 1/2W.		155200	Clock Assembly
R4	Part of C10	Resistor, 47,000 ohm		155286-1	Handle
R5	39374-39	Resistor, 15,000 ohm, 10%, 1/2W.		155272-1	Knob, Tuner, Model F-100BE
R6	39374-73	Resistor, 3.3 megohm, 10%, 1/2W.		155272-2	Knob, Tuner, Model F-100BK
R7	155206	Control, Volume, 1 megohm (Tapped at 100,000 ohm)		155272-3	Knob, Tuner, Model F-100GN
R9A	Part of C9	Resistor, 1 megohm		155272-4	Knob, Tuner, Model F-100RD
R9B		Resistor, 2.2 megohm } Assembly		155272-5	Knob, Tuner, Model F-100CE
R9C		Resistor, 4.7 megohm }		155262-1	Knob, Volume, Control
R10	39374-45	Resistor, 47,000 ohm, 10%, 1/2W.		155269-1	Knob, Timer Switch, Model F-100BE
R11	39374-85	Resistor, 10 megohm, 10%, 1/2W.		155269-3	Knob, Timer Switch, Model F-100BK
R12	39374-20	Resistor, 390 ohm, 10%, 1/2W.		155269-5	Knob, Timer Switch, Model F-100GN
R13	39374-20	Resistor, 390 ohm, 10%, 1/2W.		155269-7	Knob, Timer Switch, Model F-100RD
R14	39374-25	Resistor, 1000 ohm, 10%, 1/2W.		155269-9	Knob, Timer Switch, Model F-100CE
L1	155415	Antenna & Rod, Assembly		155269-2	Knob, Clock Wind, Model F-100BE
L2	155329	Oscillator Coil, Assembly		155269-4	Knob, Clock Wind, Model F-100BK
SP1	155159	Speaker, 4 inch (P.M.)		155269-6	Knob, Clock Wind, Model F-100GN
SW1	Part of Clock	Switch, ON-OFF, Power		155269-8	Knob, Clock Wind, Model F-100RD
SW2	155315	Switch & Bracket Assembly, "Max Battery Life"		155269-10	Knob, Clock Wind, Model F-100CE
SW3	155240	Switch, Indoor - Outdoor		155261-1	Knob (2 used), Alarm Button & Time Set Alarm, Model F-100BE
T1	145025-7	Transformer, 2nd. I.F.		155261-2	Knob (2 used), Alarm Button & Time Set Alarm, Model F-100BK
T2	145025-8	Transformer, 1st. I.F.		155261-3	Knob (2 used), Alarm Button & Time Set Alarm, Model F-100GN
T3	Part of SP1	Transformer, Audio Output		155261-4	Knob (2 used), Alarm Button & Time Alarm Set, Model F-100RD
CO1	155314	Connector Assembly, "A" Battery		155261-5	Knob (2 used), Alarm Button & Time Alarm Set, Model F-100CE
CO2	155210	Spring Grounding, "A" Battery		155280	Link (2 used), Handle Mtg.
CO3	155210	Spring Grounding, "A" Battery		153540-3	Medallion
CO4	155205	Connector, "B" Battery		94704-35	Nut, Push on Type
	155254-1	Button, "Max Battery Life Switch", Model F-100BE		155340-1	Pin, Indicator
	155254-2	Button, "Indoor - Outdoor Switch", Model F-100BE		155308	Washer, Felt
	155254-3	Button, "Max. Battery Life Switch", Model F-100BK			

MODEL	PART NO.	DESCRIPTION
F-100 Series	156178	Insert, Tuning Knob
	156180	Insert, Clock

To install a new insert, first remove the old insert; then remove the paper backing from the adhesive on the new insert and press the insert firmly in place. NOTE: When replacing a tuning knob insert, it is possible to install the new insert up-side-down. To eliminate this possibility, do not remove the tuning knob from its shaft while changing the insert.

MODEL	ORIGINAL PART NO.	CORRECT PART NO.	DESCRIPTION
F-100BE	155238-1	156779-1	Cabinet front
F-100BK	155238-2	156779-2	Cabinet front
F-100GN	155238-3	156779-3	Cabinet front
F-100RD	155238-4	156779-4	Cabinet front
F-100CE	155238-5	156779-5	Cabinet front
F-100BE	155272-1	156545-1	Knob, tuning
F-100BK	155272-2	156545-2	Knob, tuning
F-100GN	155272-3	156545-3	Knob, tuning
F-100RD	155272-4	156545-4	Knob, tuning
F-100CE	155272-5	156545-5	Knob, tuning
F-100BE	155286-1	156289-1	Handle
F-100BK	155286-1	156289-2	Handle
F-100GN	155286-1	156289-3	Handle
F-100RD	155286-1	156289-4	Handle
F-100CE	155286-1	156289-5	Handle

SUBJECT: WARNING AGAINST PARTIAL WINDING OF THE CLOCK USED ON THE F-100 SERIES CLOCK RADIOS.

Several cases have been noted where the user of a F-100 Series Clock Radio failed to wind the clock completely and then reported that the clock was defective and would not continue running more than a few hours. To meet such complaints and to prevent future complaints of the same sort, the following information is directed to all Sales and Service personnel.

On the F-100 Series Clock Radio, both the clock and the alarm are operated by the same spring. Generally, the first few turns of the wind shaft (until a click is heard after each revolution) store the energy needed for alarm operation, while any further turns store energy for the clock.

Here is why the user may fail to wind the clock completely.

Example A: Let us assume the clock is run-down, including the alarm, and that we begin winding it. For the first few turns, a certain amount of resistance in the wind shaft is felt. Then a point is reached where *more* resistance is noted and where a click is heard each time the wind shaft makes one revolution. A careful user would, most likely, stop winding for fear of causing damage. In actuality the clock has, at this point, been wound only enough for the alarm and a small portion of the clock's running time. If we want to get the full running time of 30 hours, we must continue winding comparatively for a much longer time — until the spring is fully wound (wind shaft will no longer turn without literally forcing it). Only then can the clock be considered fully wound.

Example B: For a slightly different situation let us assume that, six hours after the clock has been fully wound, the alarm goes off and runs down completely. Most of the potential energy for the clock's operation is still stored in the spring. If we wish to re-set the alarm and fully rewind the clock, we experience the same resistance as before, i. e., when starting with the clock run down. Now, when that point is reached where maximum alarm potential energy is again stored in the spring, the resistance increases more sharply than it would if the whole spring were run down. At this point, the same clicking as described in Example A is heard.

Mechanically the alarm and the clock are both operated by only one spring; three turns of the wind shaft are required to complete one revolution of the spring shaft. Fifteen to twenty complete revolutions of the spring shaft are required to wind the clock to its maximum running time of 30 hours. But, when the alarm goes off, it uses only one complete revolution of the spring shaft for its operation. When the spring shaft has been wound the first complete turn, maximum potential energy is stored in the spring for the operation of the alarm, but less than 10% is stored for clock operation. It is here that there is the tendency to stop winding.

MODELS F-110BE, BK,
CE, GN, RD, Ch. 110F

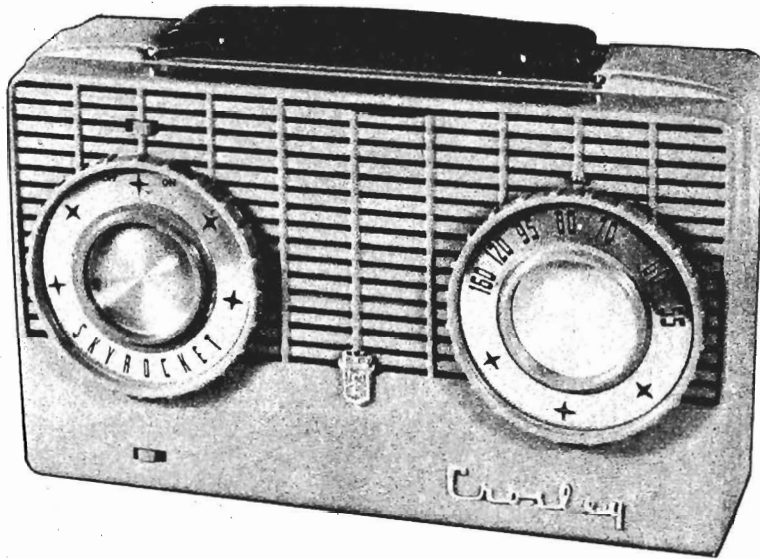

DESCRIPTION

The above Models are four tube superheterodyne, battery operated portable radio receivers. The receiver is designed for reception of Standard Broadcast (AM) stations with frequencies between 540 and 1600 kilocycles.

The receiver uses long-life "A" batteries, with provision made to use standard flash-light batteries ("D" cells) in localities where the long-life batteries are not available, with a resultant decrease in "A" battery life.

TYPE: Four-tube, single band, Superheterodyne

FREQUENCY RANGE: 540 to 1600 Kc

INTERMEDIATE FREQUENCY: 455 Kc

POWER OUTPUT: 200 Milliwatts

"A" BATTERY: Two 1½ volt Eveready #964.

"B" BATTERY: One 75 volt Eveready #437.

NOTE: Complete Battery Kit No. EV-1
(Crosley Part No. 156292)

Consists of { Two 1½ volt "A" Batteries # 964.
One 75 volt "B" Battery #437.

Available at your Crosley Distributor.

TUBE COMPLEMENT

Type	Function
1U5	Detector, AVC, 1st Audio Ampl.
1R5	Converter
3V4	Audio Output
1U4	IF Amplifier

MODELS F-110BE, BK,
CE, GN, RD, Ch. 110F**REMOVING THE CHASSIS**

1. Slip the tuning knob from the shaft of the tuning gang.
2. Open the cabinet back by lifting up on the handle and pushing down and out with the thumb on the top edge of the cabinet back; then remove the back.
3. Remove the "A" and "B" batteries.
4. Remove the chassis (Chassis is fastened to the front of the cabinet by five cross-recess screws).

ALIGNMENT PROCEDURE

1. Connect an output meter across the speaker voice coil (3.2 ohms).
2. Connect "A" and "B" batteries to the receiver.
3. Slide the "ON-OFF SWITCH" to the "ON" position.
4. Apply an R-F signal, modulated 30% at 400 cycles to the receiver as indicated in the alignment chart. Connect the signal generator ground lead to chassis.
5. Turn the volume control to maximum, set the POWER SAVER SWITCH for maximum power output.
6. Adjust the signal generator to produce mid-scale deflection on the output meter, but maintain output as low as possible to prevent AVC action.

ALIGNMENT CHART

ALIGNMENT SEQUENCE	SIGNAL GENERATOR			POSITION OF TUNING GANG	ADJUST FOR MAX. OUTPUT	REMARKS
	FREQ. IN KC.	IN SERIES WITH	TO			
1	455	.05 mfd.	Mixer grid	Open	A & B	
2	455	.05 mfd.	Mixer grid	Open	C & D	
3	Repeat steps 1 and 2 until maximum output is obtained.					
4	1620	Radiated	Built-in Ant.	Open	E	Note 1
5	1400	Radiated	Built-in Ant.	Tune-in Sig.	F	Note 1 & 2

NOTES:

1. The signal can be radiated to the built-in antenna by placing the output lead of the signal generator close to the antenna.
2. Replace the chassis in the cabinet by reversing the order of the removal procedure listed above.

MODELS F-110BE, BK,
CE, GN, RD, Ch. 110F

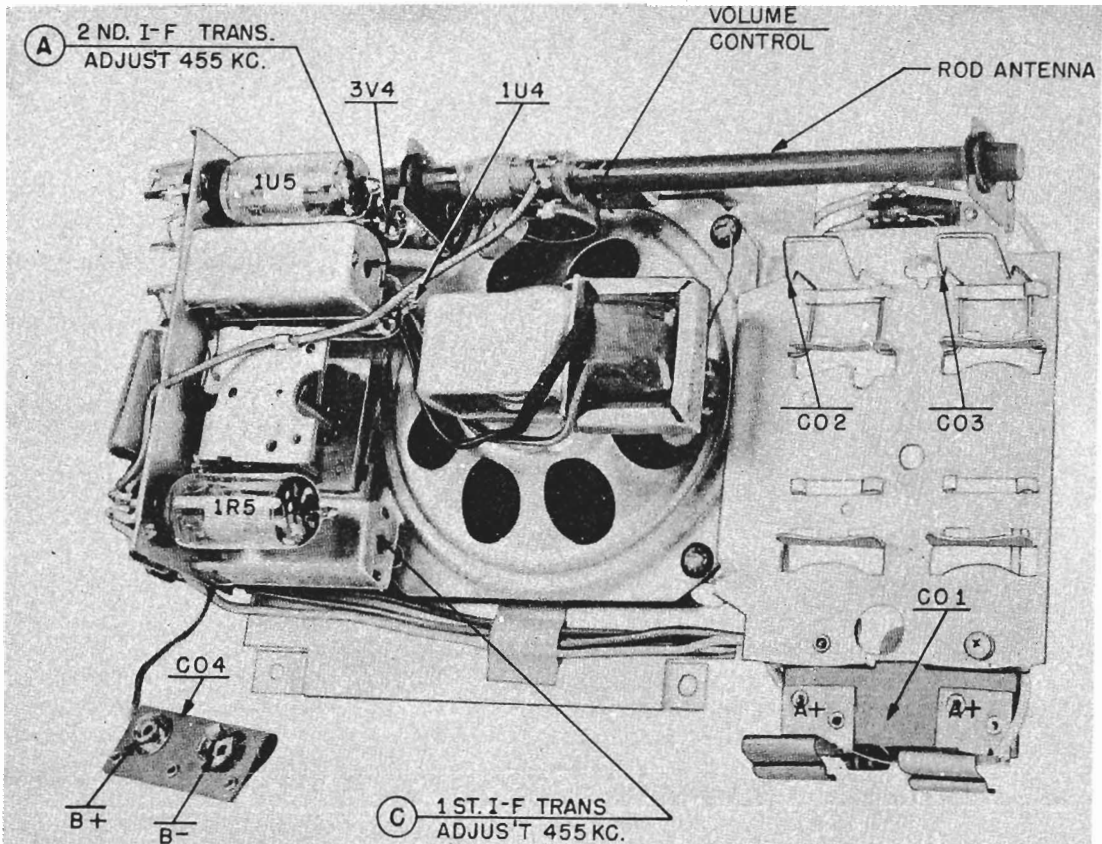

CHASSIS, REAR VIEW

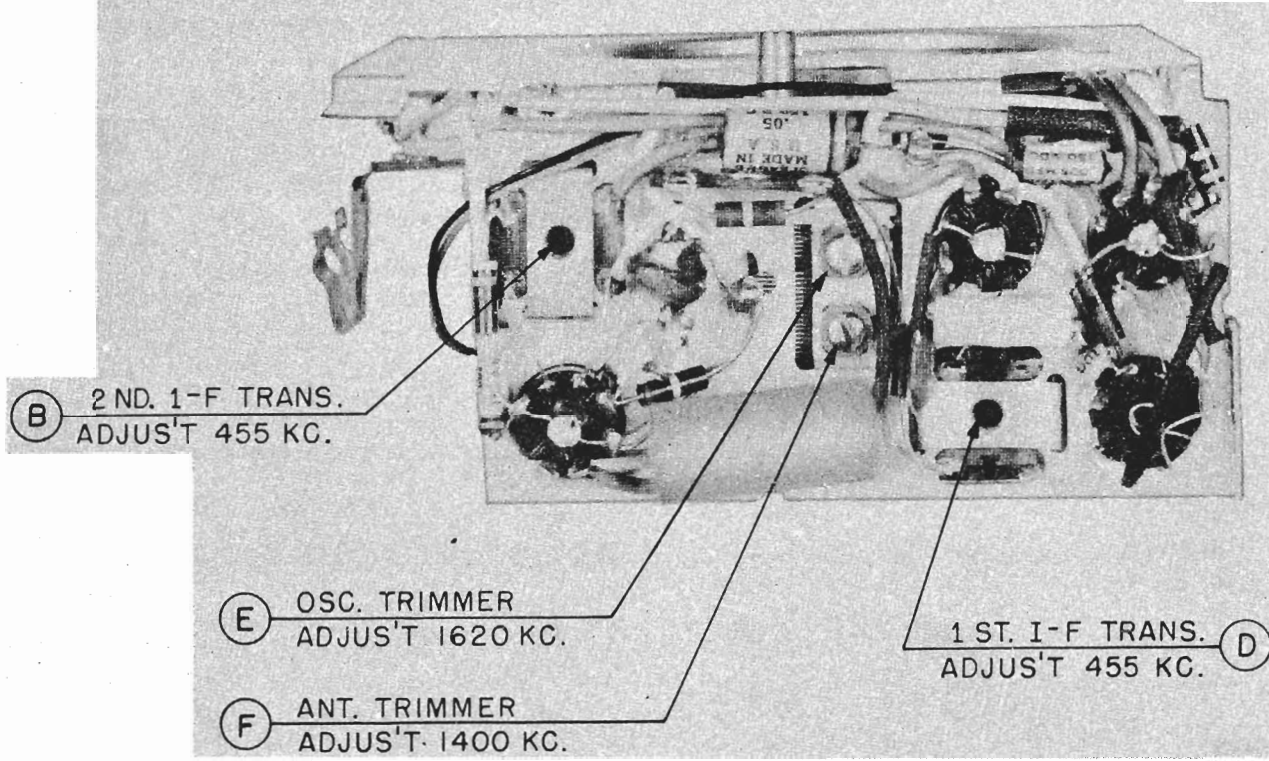

CHASSIS, BOTTOM VIEW

MODELS F-110BE, BK,
CE, GN, RD, Ch. 110F

SOCKET VOLTAGE CHART

NOTES:

1. BOTTOM VIEW OF TUBE SOCKETS.
2. VOLTAGES MEASURED WITH AN ELECTRONIC VOLTMETER FROM SOCKET LUG TO CHASSIS.
3. BATTERY SUPPLY VOLTAGES "A" BATTERY 15V. "B" BATTERY 75V.
4. BATTERY SWITCH IN "MAX. POWER OUTPUT" POSITION. "OUTDOOR INDOOR" SWITCH IN "OUTDOOR" POSITION.
5. N.C. = NO CONNECTION, W.J. = WIRE JUNCTION.
6. SOCKET VOLTAGE TOLERANCE $\pm 10\%$.

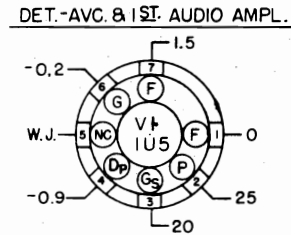
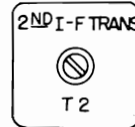
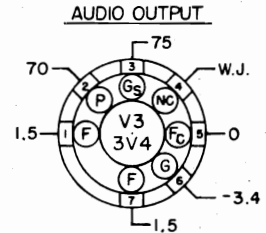
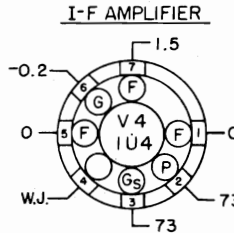
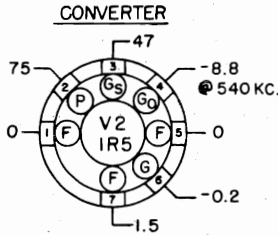
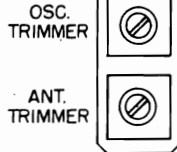
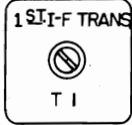

PARTS LIST

Symbol No.	Part No.	Description	Symbol No.	Part No.	Description
C1A	155290	Capacitor, Tuning		155254-2	Button, "Indoor - Outdoor Switch", Model F-110 BE
C1B		Capacitor, Tuning		155254-3	Button, "Max Battery Life Switch", Model F-110 BK
C2	137727-109	Capacitor, 39 mmf., 10%, 200 V., ceramic		155254-4	Button, "Indoor - Outdoor Switch", Model F-110 BK
C3	Part of T1	Capacitor		155254-5	Button, "Max Battery Life Switch", Model F-110 GN
C4	Part of T1	Capacitor		155254-6	Button, "Indoor - Outdoor Switch", Model F-110 GN
C5	39433-10	Capacitor, .002 mfd., 150 V., paper		155254-7	Button, "Max Battery Life Switch", Model F-110 RD
C6	144675-2	Capacitor, .005 mfd., 500 V., disc ceramic		155254-8	Button, "Indoor - Outdoor Switch", Model F-110 RD
C7	Part of T2	Capacitor		155254-9	Button, "Max Battery Life Switch", Model F-110 CE
C8	Part of T2	Capacitor		155254-10	Button, "Indoor - Outdoor Switch", Model F-110 CE
C9A	151550-3	Capacitor, 5000 mmf., 450 V.		155811-1	Cabinet Assembly, Model F-110 BE
C9B		Capacitor, 5000 mmf., 450 V.		155811-2	Cabinet Assembly, Model F-110 BK
C9C		Capacitor, 100 mmf., 450 V.		155811-3	Cabinet Assembly, Model F-110 GN
C10A	142951-2	Capacitor, 100 mmf., 450 V.		155811-4	Cabinet Assembly, Model F-110 RD
C10B		Capacitor, 100 mmf., 500 V.		155811-5	Cabinet Assembly, Model F-110 CE
C11	39433-11	Capacitor, .005 mfd., 150 V., paper		155239-1	Cabinet, Back, Model F-110 BE
C12	39433-14	Capacitor, .05 mfd., 150 V., paper		155239-2	Cabinet, Back, Model F-110 BK
C13	39433-14	Capacitor, .05 mfd., 150 V., paper		155239-3	Cabinet, Back, Model F-110 GN
C14	144675-28	Capacitor, .001 mfd., 500 V., disc ceramic		155239-4	Cabinet, Back, Model F-110 RD
C15	137727-121	Capacitor, .005 mfd., 10%, 500 V., ceramic		155239-5	Cabinet, Back, Model F-110 CE
C16	155355	Capacitor, 10 mfd., 80 V., Electrolytic		155813-1	Cabinet, Front, Model F-110 BE
R1	39374-49	Resistor, 100,000 ohm, 10%, 1/2W.		155813-2	Cabinet, Front, Model F-110 BK
R2	39374-77	Resistor, 4.7 megohm, 10%, 1/2W.		155813-3	Cabinet, Front, Model F-110 GN
R3	39374-25	Resistor, 1000 ohm, 10%, 1/2W.		155813-4	Cabinet, Front, Model F-110 RD
R4	Part of C10	Resistor, 47,000 ohm		155813-5	Cabinet, Front, Model F-110 CE
R5	39374-39	Resistor, 15,000 ohm, 10%, 1/2W.		156182-1	Escutcheon, Model F-110 BE
R6	39374-73	Resistor, 3.3 megohm, 10%, 1/2W.		156182-2	Escutcheon, Model F-110 BK
R7	155786	Control, Volume, 1 megohm		156182-3	Escutcheon, Model F-110 GN
R9A	Part of C9	Resistor, 1 megohm		156182-4	Escutcheon, Model F-110 RD
R9B		Resistor, 2.2 megohm		156182-5	Escutcheon, Model F-110 CE
R9C		Resistor, 4.7 megohm		155286-1	Handle
R10	39374-45	Resistor, 47,000 ohm, 10%, 1/2W.		156086-1	Knob, Tuner Model F-110 BE
R11	39374-85	Resistor, 10 megohm, 10%, 1/2W.		156086-2	Knob, Tuner Model F-110 BK
R12	39374-20	Resistor, 390 ohm., 10%, 1/2W.		156086-3	Knob, Tuner Model F-110 GN
R13	39374-20	Resistor, 390 ohm, 10%, 1/2W.		156086-4	Knob, Tuner Model F-110 RD
R14	39374-25	Resistor, 1000 ohm, 10%, 1/2W.		156086-5	Knob, Tuner Model F-110 CE
L1	155415	Antenna & Rod, Assembly		155262-1	Knob, Volume Control
L2	155329	Oscillator Coil, Assembly		155280	Link (2 used), Handle Mtg.
SP1	155159	Speaker, 4 inch (P.M.)		153540-3	Medallion
SW1	155242	Switch, ON - OFF, Power		94704-35	Nut, Push On Type
SW2	155315	Switch Bracket Assembly, "Max Battery Life"		155340-1	Pin, Indicator
T1	145025-7	Transformer, 2nd. IF		155308	Washer, Felt
T2	1450025-8	Transformer, 1st. IF			
T3	Part of SP1	Transformer, Audio Output			
CO1	155314	Connector Assembly, "A" Battery			
CO2	155210	Spring Grounding, "A" Battery			
CO3	155210	Spring Grounding, "A" Battery			
CO4	155205	Connector, "B" Battery			
	155254-1	Button, "Max Battery Life Switch", Model F-110 BE			

MODELS F-110BE, BK,
CE, GN, RD, Ch. 110F

SUBJECT— CORRECT PART NUMBERS FOR CABINET FRONTS, TUNING KNOBS FOR F-110 SERIES

MODEL	ORIGINAL PART NO.	CORRECT PART NO.	DESCRIPTION
F-110BE	155813-1	156779-1	Cabinet front
F-110BK	155813-2	156779-2	Cabinet front
F-110GN	155813-3	156779-3	Cabinet front
F-110RD	155813-4	156779-4	Cabinet front
F-110CE	155813-5	156779-5	Cabinet front
F-110BE	156086-1	156547-1	Knob, tuning
F-110BK	156086-2	156547-2	Knob, tuning
F-110GN	156086-3	156547-3	Knob, tuning
F-110RD	156086-4	156547-4	Knob, tuning
F-110CE	156086-5	156547-5	Knob, tuning
F-110BE	155286-1	156289-1	Handle
F-110BK	155286-1	156289-2	Handle
F-110GN	155286-1	156289-3	Handle
F-110RD	155286-1	156289-4	Handle
F-110CE	155286-1	156289-5	Handle

**SUBJECT— ADDITIONAL PART NUMBERS
PORTABLE RADIOS**

The part numbers in the table below should be added to the parts list

MODEL	PART NO.	DESCRIPTION
F-110 Series	156179	Insert, Tuning Knob
	156173	Insert, Escutcheon

To install a new insert, first remove the old insert; then remove the paper backing from the adhesive on the new insert and press the insert firmly in place.

NOTE: When replacing a tuning knob insert, it is possible to install the new insert up-side-down. To eliminate this possibility, do not remove the tuning knob from its shaft while changing the insert.

**MODELS F-25BE, BK,
GN, MN, Ch. 25F**

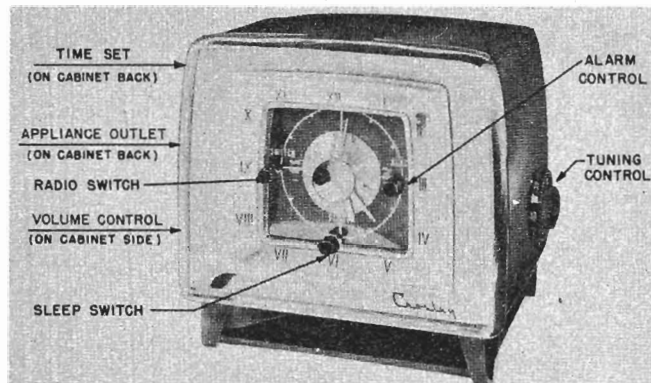

DESCRIPTION

TYPE: Five-tube, single band, Superheterodyne.

FREQUENCY RANGE: 540 to 1600 kc.

INTERMEDIATE FREQUENCY: 455 kc.

POWER SUPPLY: 60 cycle, a.c. only.

VOLTAGE RATING: 105-125 volts.

POWER OUTPUT: 1 watt maximum.

POWER CONSUMPTION:

- Radio and Clock.....35 watts
- Clock 2 watts

SLEEP SWITCH — Set it up to 60 minutes operation of radio or appliance — turns them off automatically.

ELECTRIC CLOCK of highest accuracy. The face is provided with luminous hour and minute hands for easy reading in the dark. Sweep second hand of red; clock controls of same color as cabinet.

RADIO SWITCH has three positions: "Off" to turn off radio; "Auto" to turn radio or appliance on automatically; "On" for manual radio operation.

APPLIANCE OUTLET is provided at rear of set for connecting any appliance (not exceeding 1100 watts) to be controlled by timing device.

TIME SET, for setting clock to time of day.

ALARM CONTROL — Set it for time radio or appliance is to turn on automatically. Pull out

TUBE COMPLEMENT:

Type	Function
12BE6	Converter
12BA6	I. F. Amplifier
12AT6	Detector, AVC, 1st. A. F. Amplifier
50C5	A. F. Power Output
35W4	Rectifier

to have buzzer sound a few minutes after radio turns on.

DRIFT-FREE TUNING, accomplished by Crosley frequency stabilized oscillator, keeps receiver aligned precisely with station to which you have tuned.

EXCEPTIONALLY FINE TONE — The result of advanced engineering of the Crosley circuit and components.

INCREASED SENSITIVITY AND STABILITY. Permeability tuned (iron core) IF transformers give greater stability and sensitivity so that distant stations can be received with minimum interference.

AUTOMATIC VOLUME CONTROL holds the volume as you set it.

BUILT-IN ANTENNA to provide satisfactory reception from AM broadcast stations within range of the receiver.

MODELS F-25BE, BK,
GN, MN, Ch. 25F

Under no circumstances should a ground be connected to this receiver.

ALIGNMENT PROCEDURE

1. Connect an output meter across the speaker voice coil (3.2 ohms).
2. Feed an R-F signal modulated 30% at 400 cycles to the receiver, as indicated in the alignment chart. Connect signal generator ground through a 0.1 mfd capacitor to B-.
3. Turn the Radio Switch to the "ON" position.
4. Turn the Volume Control to maximum clockwise position and adjust the signal generator output to produce approximately mid-scale deflection of the output meter, but maintain signal generator output as low as possible to prevent AVC action.

ALIGNMENT CHART

Alignment locations shown on page 41.

Alignment Sequence	Signal Generator Output			Position of Tuning Gang	Adjust for Max. Output	Remarks
	Freq. in KC.	In Series With	To			
1	455	200 mmf.	Mixer grid, pin 7 of V5	Open	A & B	See note 1
2	455	200 mmf.	Mixer grid, pin 7 of V5	Open	C & D	See note 1
3 Repeat steps 1 and 2 until maximum output is obtained.						
4	1620	Radiated Sig.	Antenna	Open	E	See note 2
5	1400	Radiated Sig.	Antenna	Tune in Signal	F	See note 2

Notes:

1. The bottom slugs of the I. F. Transformers can be adjusted through the holes in the front plate opposite the transformers.
2. The signal can be radiated to the antenna by placing the output lead of the signal generator close to the antenna rod.

CLOCK ADJUSTMENTS

Procedure for checking timer switch and vibrator:

1. With the time set knob, turn the clock hands so as to advance the time at least one (1) hour. (For ease in checking, it is recommended that the time be set to the hour.)
2. Attach test light to switch leads.
3. Turn switch knob to "ON" position - light must go on.
4. Turn switch knob to "OFF" position - light must go out.
5. Set alarm disc so that small pointer on hour hand reads two (2) hours in advance of the time of the clock. EXAMPLE: If the clock hands are set to read 7 o'clock, set the alarm disc to read 9 o'clock.
6. Turn sleep switch to "60" - test light must go on.
7. Turn time set knob advancing clock hands to next hour—light must go out and SLEEP SWITCH SECTOR GEAR must be completely disengaged within one (1) hour plus or minus eight (8) minutes.

**MODELS F-25BE, BK,
GN, MN, Ch. 25F**

8. Manually push SLEEP SWITCH SECTOR GEAR in until it touches its mating pinion WITHOUT meshing - light must go on.
9. Turn switch knob to "AUTO" position.
10. Turn time set knob to advance clock hands so they read 15 minutes until the next hour. Then slowly advance the hands until the test light lights, which indicates the contacts are closed. The contacts must close somewhere between 14 minutes to the hour and 4 minutes past the hour.
11. Remove test light and connect 110 volt supply to the motor terminals.
12. Turn time set knob to advance the clock hands 4 minutes - vibrator must NOT buzz. Then advance the hands 14 minutes - vibrator MUST buzz within this 14 minute period.

Adjusting Contacts

1. Set the switch to "AUTO" position so that the SWITCH CAM FOLLOWER rests on the TIMING CAM. Contacts shall be adjusted at .020" minimum gap.
2. With switch in "OFF" position contacts shall remain open as in step one and there shall be clearance between SWITCH CAM FOLLOWER and TIMING CAM.
3. With switch in "ON" position, contacts shall be closed. Check for proper contact pressure by depressing LOWER CONTACT strip, using a small pointed tool. If UPPER CONTACT strip follows the LOWER CONTACT strip a noticeable amount before the contacts separate, the pressure is sufficient.
4. Set the switch to "AUTO" position; pull out and turn alarm set knob counter-clockwise until the SWITCH CAM FOLLOWER drops into the slot of TIMING CAM. The contacts shall be closed. Check contact pressure as previously described in step three.
5. SWITCH ARM should clear CAM by .008" minimum when in the "AUTO" position.

Timing

1. Adjust timer for contact closure at 6:55 o'clock. On repeat tests, contacts shall close at 6:55 plus or minus 3 minutes. At all other settings the contacts shall close between 12 minutes before and 2 minutes after the setting time.
2. Check time keeping for a minimum of twelve hours with power applied to the motor. Clock must be run with vibrator (buzzer) shut off.

Vibrator Adjustment

1. Vibrator shall start buzzing 10 minutes plus or minus 5 minutes after contact closure occurs.
2. When the alarm set knob is pushed in ("shut-off" position of vibrator) the shut-off spring shall lift the vibrator sufficiently above the cam, so that the cam will not contact the vibrator in any position.
3. Adjust vibrator for good sounding position.
4. Vibrator shall be manually shut off before completion of buzzing period.

CLOCK LUBRICATION

1. Center stack bearing in base plate and hole in back gear pinion should be lubricated with Nye watch oil or equivalent.
2. Path of switch locating spring on bracket should be lubricated with Dixon graphite grease.

MODELS F-25BE, BK, GN, MN, Ch. 25F

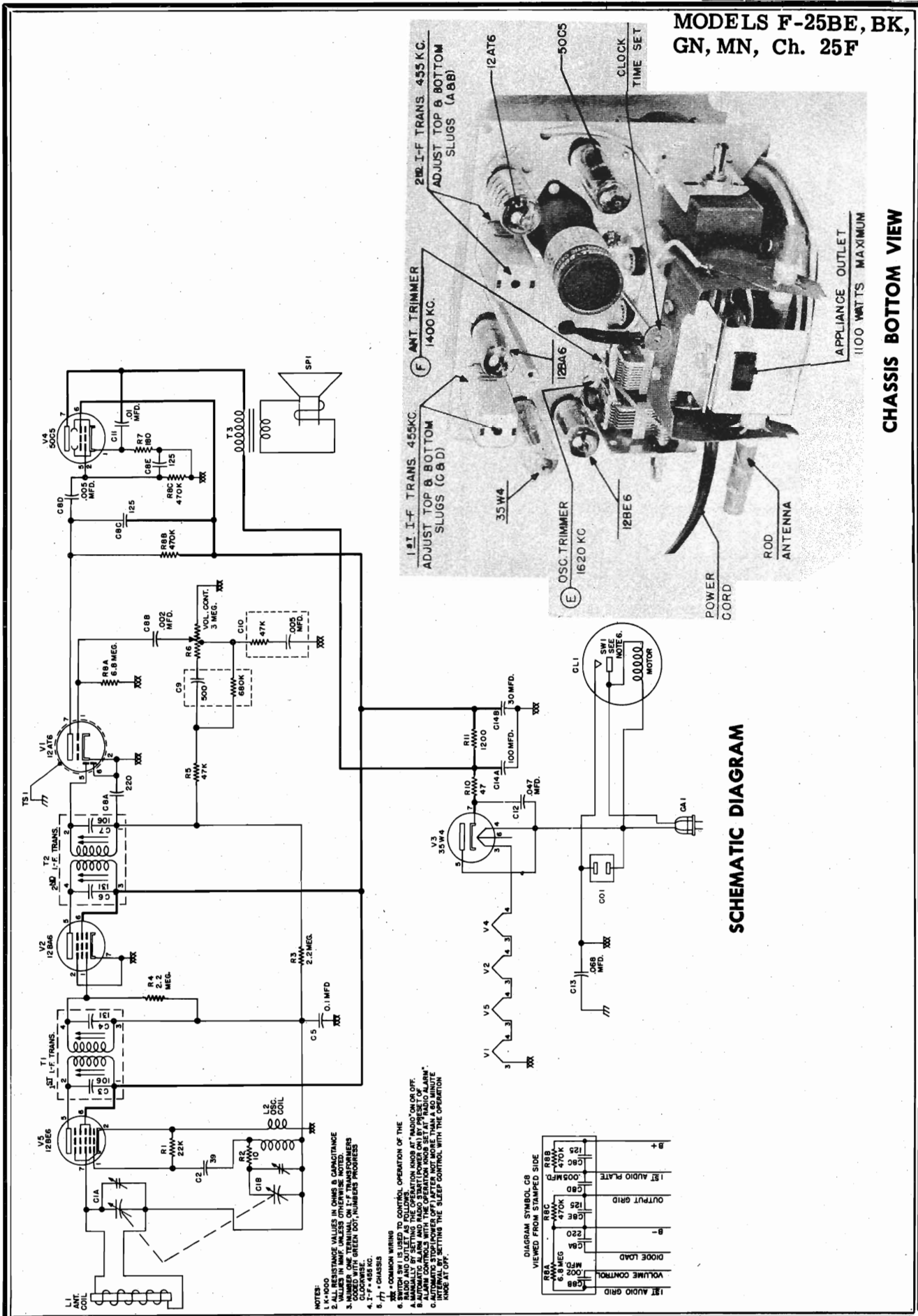

- NOTES:
 1. ANT. COIL
 2. ALL RESISTANCE VALUES IN OHMS & CAPACITANCE VALUES IN MFD. UNLESS OTHERWISE NOTED.
 3. VALUES IN MFD. UNLESS OTHERWISE NOTED.
 4. VALUES IN OHMS UNLESS OTHERWISE NOTED.
 5. CODED WITH GREEN DOT, NUMBERS PROGRESSIVE.
 6. 1/4" x 485 KC.
 7. 1/4" x 485 KC.
 8. 1/4" x 485 KC.
 9. 1/4" x 485 KC.
 10. CHASSIS
 11. COMMON WIRING
 12. SWITCH SW 1 IS USED TO CONTROL OPERATION OF THE "RADIO" OR "ON OFF."
 13. MANUALLY SETTING THE OPERATION knob AT "RADIO" OR "OFF."
 14. AUTOMATIC ALARM AND ALSO SHUT DOWN ONLY AT "SLEEP ALARM."
 15. AUTOMATIC STOP POWER OFF AFTER NOT MORE THAN 80 MINUTE.
 16. AUTOMATIC STOP POWER OFF AFTER NOT MORE THAN 80 MINUTE AFTER SETTING THE SLEEP CONTROL WITH THE OPERATION knob AT OFF.

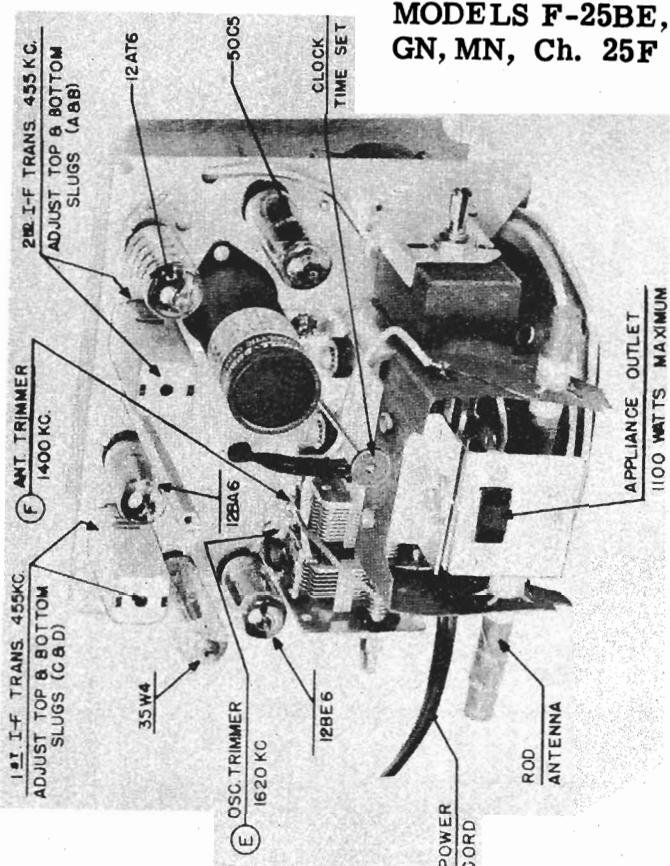
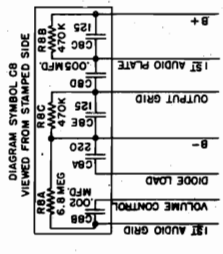

CHASSIS BOTTOM VIEW

SCHEMATIC DIAGRAM

MODELS F-25BE, BK,
GN, MN, Ch. 25F

SOCKET VOLTAGE CHART

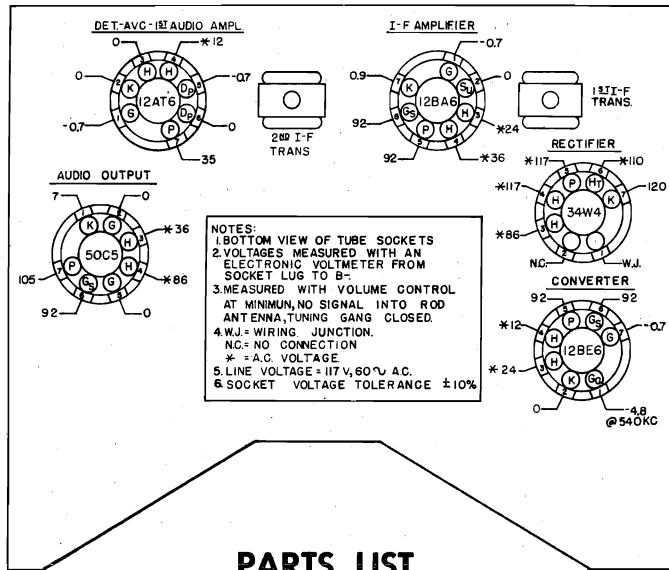

PARTS LIST

Symbol No.	Part No.	Description	Symbol No.	Part No.	Description
C1A } C1B } C2	154559 137727-109	Capacitor, 2 Section, Tuning Capacitor, Ceramic 39 mmf., 10%, 200 v.	SW1	Part of CL1	Switch, on-off
C3	Part of T1	Capacitor, 106 mmf.	T1	139919-3	Transformer, 1st. I. F.
C4	Part of T1	Capacitor, 131 mmf.	T2	139919-3	Transformer, 2nd. I. F.
C5	39477-47	Capacitor, 0.1 mfd., 600 v., Molded Paper	T3	147171	Transformer, Audio Output
C6	Part of T2	Capacitor, 131 mmf.	CL1	154916-1	Clock Assembly, Model F-25BK
C7	Part of T2	Capacitor, 106 mmf.	CL1	154916-2	Clock Assembly, Model F-25MN
C8A } C8B } C8C } C8D } C8E }	151550-1	Capacitor, 220 mmf. Capacitor, .002 mfd. Capacitor, 125 mmf. Capacitor, .005 mfd. Capacitor, 125 mmf.	CL1	154916-3	Clock Assembly, Model F-25BE
C9	142951-12	Capacitor Resistor Unit; 500 mmf., 500 v., 680,000 ohm, 1/5 w. Min.	CL1	154916-4	Clock Assembly, Model F-25GN
C10	142951-11	Capacitor Resistor Unit; .005 mfd., 500 v., 47,000 ohm, 1/5 w. Min.	CO1	154639	Appliance Outlet & Bracket Assembly
C11	39477-41	Capacitor, .01 mfd., 600 v., Molded Paper	154809	Bracket, Speaker Mounting	
C12	39477-45	Capacitor, .047 mfd., 600 v., Molded Paper	155180	Cabinet (Model F-25BK)	
C13	39477-46	Capacitor, .068 mfd., 600 v., Molded Paper	155285-1	Cabinet (Model F-25MN)	
C14A } C14B }	154561	Capacitor, 100 mfd., 150 v., } Assem- Capacitor, 30 mfd., 100 v., } bly	155285-2	Cabinet (Model F-25GN)	
R1	39374-41	Resistor, 22,000 ohm, 1/2 w.	155285-3	Cabinet (Model F-25BE)	
R2	39374-1	Resistor, 10 ohm, 1/2 w.	157013	Clamp, Power Cable	
R3	39374-69	Resistor, 2.2 megohm, 1/2 w.	154320	Face, Clock Dial	
R4	39374-69	Resistor, 2.2 megohm, 1/2 w.	149339-2	Knob, Alarm Set (Model F-25BK)	
R5	39375-45	Resistor, 47,000 ohm, 1/2 w.	149339-11	Knob, Alarm Set (Model F-25BE)	
R6	154560	Control, Volume, 3 megohm	149339-12	Knob, Alarm Set (Model F-25GN)	
R7	39374-16	Resistor, 180 ohm, 1/2 w.	149339-13	Knob, Alarm Set (Model F-25MN)	
R8A } R8B } R8C }	Part of C8 Part of C8 Part of C8	Resistor, 6.8 megohm Resistor, 470,000 ohm Resistor, 470,000 ohm	154993-2	Knob, Small, Tuning (Model F-25MN)	
R10	39374-97	Resistor, 47 ohm, 1 w.	154993-3	Knob, Small, Tuning (Model F-25BK)	
R11	39374-114	Resistor, 1200 ohm, 1 w.	154993-4	Knob, Small, Tuning (Model F-25BE)	
CA1	149780-2	Cable & Plug, Power	154993-5	Knob, Small, Tuning (Model F-25GN)	
L1	155014	Antenna Coil & Support Assembly	149311-2	Knob (2 used), Radio Switch & Sleep Switch (Model F-25BK)	
L2	153405	Oscillator Coil Assembly	149311-11	Knob (2 used), Radio Switch & Sleep Switch (Model F-25BE)	
SP1	154812-1	Speaker, 5 1/4" P. M.	149311-12	Knob (2 used), Radio Switch & Sleep Switch (Model F-25GN)	
TS1	147784-1	Shield, Tube	149311-13	Knob (2 used), Radio Switch & Sleep Switch (Model F-25MN)	
			154998-1	Knob, Tuning Dial (Model F-25MN)	
			154998-2	Knob, Tuning Dial (Model F-25BK)	
			154998-3	Knob, Tuning Dial (Model F-25BE)	
			154998-4	Knob, Tuning Dial (Model F-25GN)	
			154993-1	Knob, Volume Control (Model F-25MN)	
			154993-6	Knob, Volume Control (Model F-25BK)	
			154993-7	Knob, Volume Control (Model F-25BE)	
			154993-8	Knob, Volume Control (Model F-25GN)	
			154521-2	Molding, Trim	
			154313	Nail, Channel Indicator	
			155968	Rod, Support	
			39452-2	Socket, Tube (5 used)	
			45580-2	Washer, Rubber, Speaker Mtg. (2 used)	

MODELS F-115GN,
MN, TN, Ch. 115F

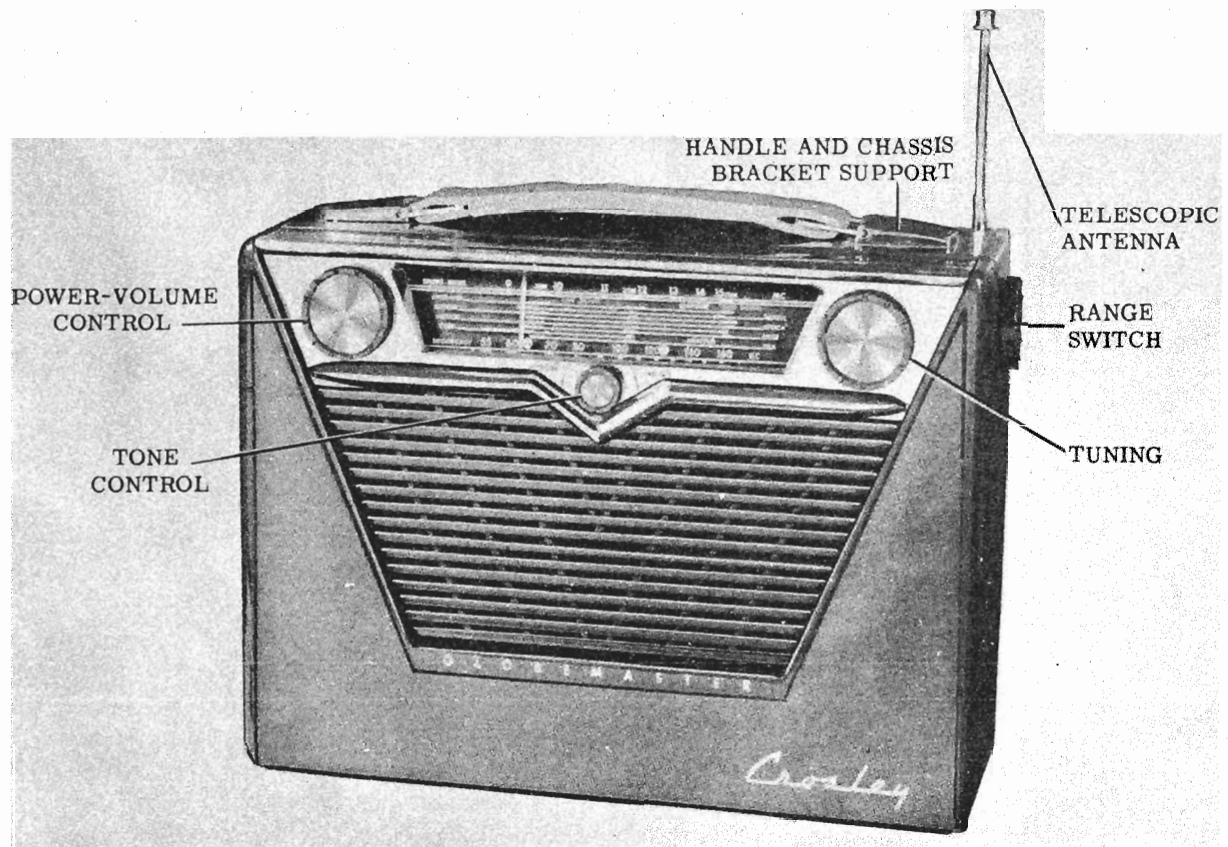

DESCRIPTION

These Crosley Models are five-tube, two band portable radio receivers employing a superheterodyne circuit and are designed to operate on an "A-B" battery pack or to operate directly from 105 to 125 volts, alternating current (50 to 60 cycles) or direct current power lines. A selenium rectifier supplies the "A" and "B" voltage when the receiver is being operated on the power lines. The tuning range covers the AM Broadcast Band, 540 to 1600 kilocycles, and the Shortwave Band, 8.4 to 15.4 megacycles.

Civilian Defense Emergency frequencies fall within the AM Broadcast Band, and the markers " \triangle CD " on the dial at 1240 Kc. and 640 Kc. designate the spot on the dial where stations may be received when they are operating on the emergency frequencies. Reception points for Standard Time Signal transmitted by U. S. Bureau of Standards' Station WWV are marked in red at 10 and 15 megacycles on the shortwave portion of the dial.

FREQUENCY RANGE: 540 to 1600 Kc.
8.4 to 15.4 Mc.

INTERMEDIATE FREQUENCY: 455 Kc.

POWER OUTPUT: 300 milliwatts

POWER CONSUMPTION: 13 watts at 117 volts A.C. or D.C.

POWER REQUIREMENTS: 105-125 volts, 50 to 60 cycles A.C.
105-125 volts D.C.
Battery Pack (Crosley part number 156745) with 9 volts "A" and 90 volts "B".

TUBE COMPLEMENT:

TUBE TYPE	FUNCTION
1U4	R. F. Amplifier
1L6	Oscillator & Mixer
1U4	I. F. Amplifier
1U5	Diode Detector - AVC - 1st Audio Amplifier
3V4	Audio Output

MODELS F-115GN,
MN, TN, Ch. 115F

SERVICE ALIGNMENT PROCEDURE

1. Connect output meter across speaker voice coil (3.2 ohms).
2. Feed an R-F signal modulated 30% at 400 cycles to the receiver as indicated below in the alignment chart.
3. Preset gang trimmers, oscillator section open, mixer and R-F section closed.
4. Turn the volume control to full on and the tone control to high frequency position. Adjust the generator to produce approximately mid-scale deflection of the output meter, but maintain generator output as low as possible to prevent a-v-c action.
5. The "Dummy" shown in Fig. 1 is to be used in steps 2 & 3 in the alignment procedure.

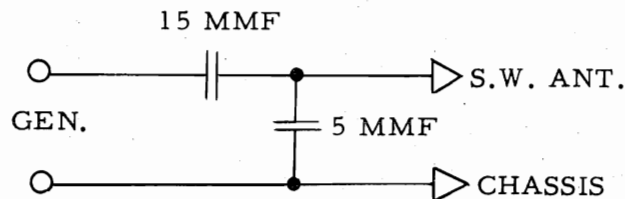

Fig. 1. Shortwave Dummy

ALIGNMENT CHART

SEQUENCE	SIGNAL GENERATOR OUTPUT			POSITION OF		ADJUST FOR MAX. OUTPUT	REMARKS
	FREQUENCY	IN SERIES WITH	TO	RANGE SWITCH	TUNING DIAL		
1	455Kc	.05 mfd	Note 1	S.W.	Gang open	A,B,C,D	Note 1
	Repeat adjustments to obtain maximum output						Note 2
2	15.7Mc	Dummy	S.W. Antenna	S.W.	Gang open	E	Note 3 & 6
3	15Mc	Dummy	S.W. Antenna	S.W.	Tune in Sig.	F,G	Note 3 & 4
4	1620Kc	Radiated	B.C. Antenna	B.C.	Gang open	H	Note 5
5	1400Kc	Radiated	B.C. Antenna	B.C.	Tune in Sig.	I,J	Note 5

NOTES:

1. Low side of generator returned to B- on electrolytic capacitor, high side of generator connected to stator of gang capacitor, center section.
2. After aligning I-F Transformers, replace bottom cover of chassis.
3. Low side of generator returned to chassis, high side of generator connected to shortwave antenna through dummy.
4. Peak center trimmer (mixer section) and rear trimmer (antenna section by rocking gang to secure maximum output.)
5. Radiate signal from generator to rod antenna by placing wire attached to high side of generator close to the rod antenna opposite to the end that is wired to the gang stator.
6. Do not align the shortwave oscillator to image at 14 megacycles.

CHASSIS, REAR VIEW

MODELS F-115GN,
MN, TN, Ch. 115F

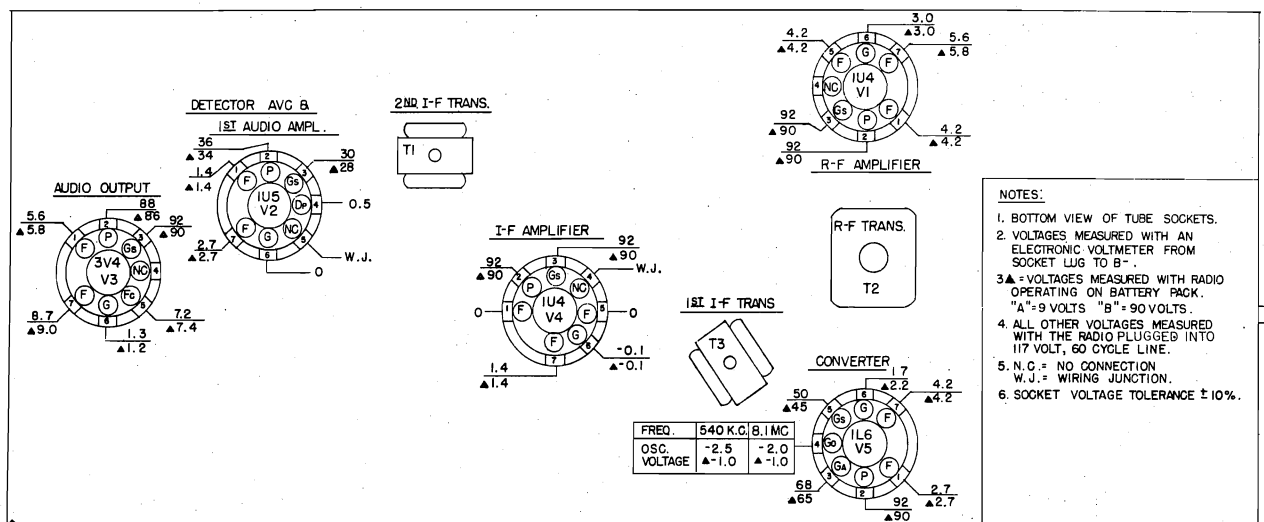
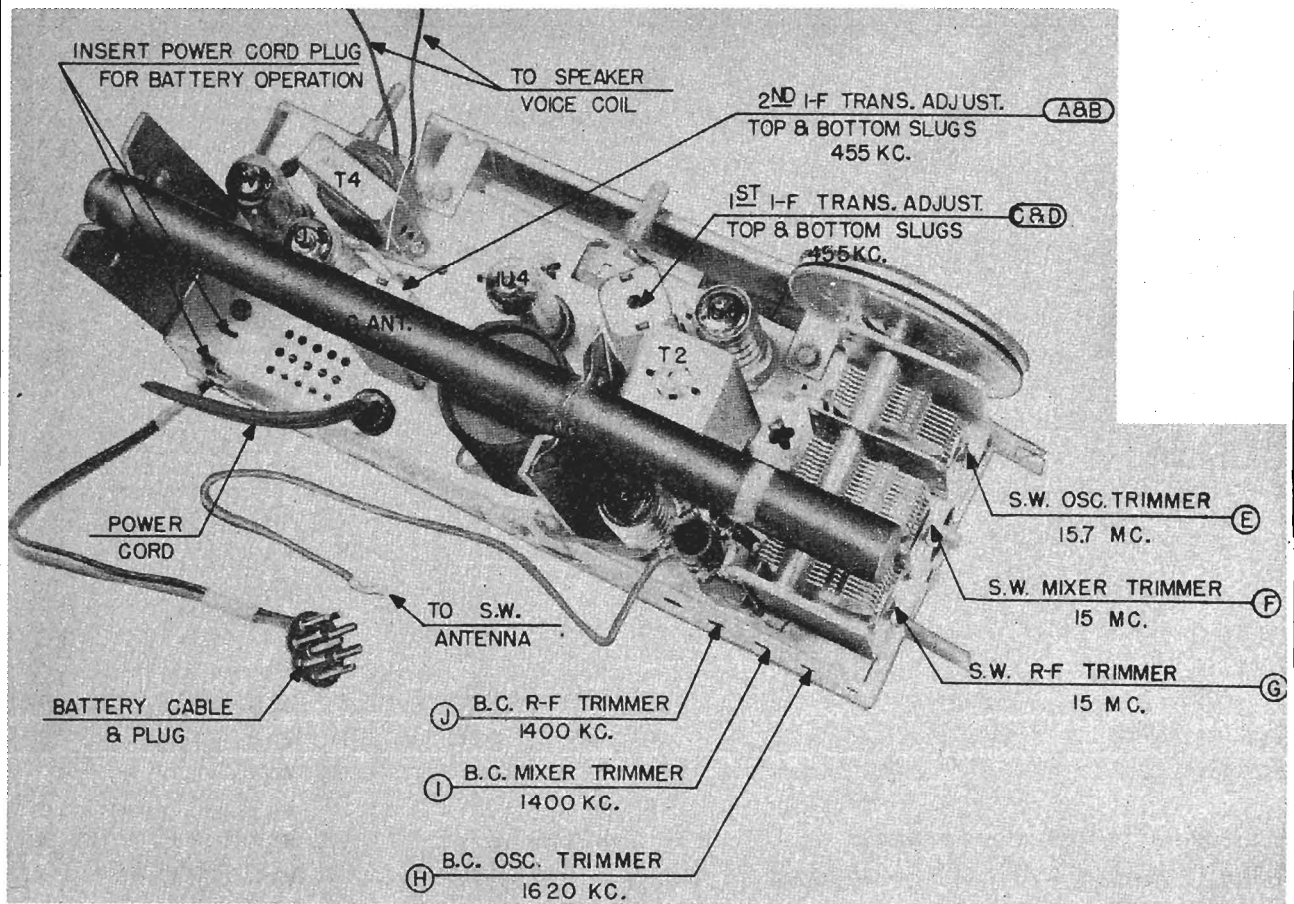

- NOTES:
1. BOTTOM VIEW OF TUBE SOCKETS.
 2. VOLTAGES MEASURED WITH AN ELECTRONIC VOLTMETER FROM SOCKET LUG TO B.
 3. ▲ = VOLTAGES MEASURED WITH RADIO OPERATING ON BATTERY PACK. "A" = 9 VOLTS "B" = 90 VOLTS.
 4. ALL OTHER VOLTAGES MEASURED WITH THE RADIO PLUGGED INTO 117 VOLT, 60 CYCLE LINE.
 5. N.C. = NO CONNECTION W.J. = WIRING JUNCTION.
 6. SOCKET VOLTAGE TOLERANCE ± 10%.

SOCKET VOLTAGE CHART

MODELS F-115GN,
MN, TN, Ch. 115F

BATTERY INSTALLATION

To open the cabinet, lift up on the handle and use the thumb to push down and out on the top edge of the cabinet back. The back is hinged at the bottom. Place the battery pack under the flexible webbing strap, and insert the battery cable plug into the battery socket. To replace the back, place the curved portion of the hinge plates on the bottom of the cabinet back over the hinge pins on the bottom of the cabinet. Push the back forward until it locks into the top of the cabinet.

CAUTION: Never allow run-down batteries to remain in the cabinet, and remove the battery pack when the receiver is stored for an extended period.

ANTENNAS

Two built-in antennas are provided: an iron core, high efficiency rod antenna for standard broadcast reception, and for shortwave reception, a vertical telescoping antenna that can be pushed down in the cabinet when not in use.

When removing or opening the back of the cabinet, be sure that the clip on the wire from the coil next to the tuning gang, is on the pin of the bracket that supports the telescoping antenna.

OPERATION

Battery Operation: - Open the back of the cabinet. It will be noted that a flat spring is located on the back of the chassis on the battery cable side, and also a slot in the chassis on the underside. For battery operation, one of the prongs of the power cord plug must be inserted in this slot and the other prong over the spring. This operates the line-battery switch (SW1). After inserting the plug, close the cabinet back.

AC or DC Operation: - For 105 to 125 volt, 50 to 60 cycle alternating current or direct current power line operation, remove the power cord plug from the receptacle on the chassis and connect to the electrical outlet. The power cord may be brought out of the cabinet through the slot provided at the lower right hand corner of the cabinet.

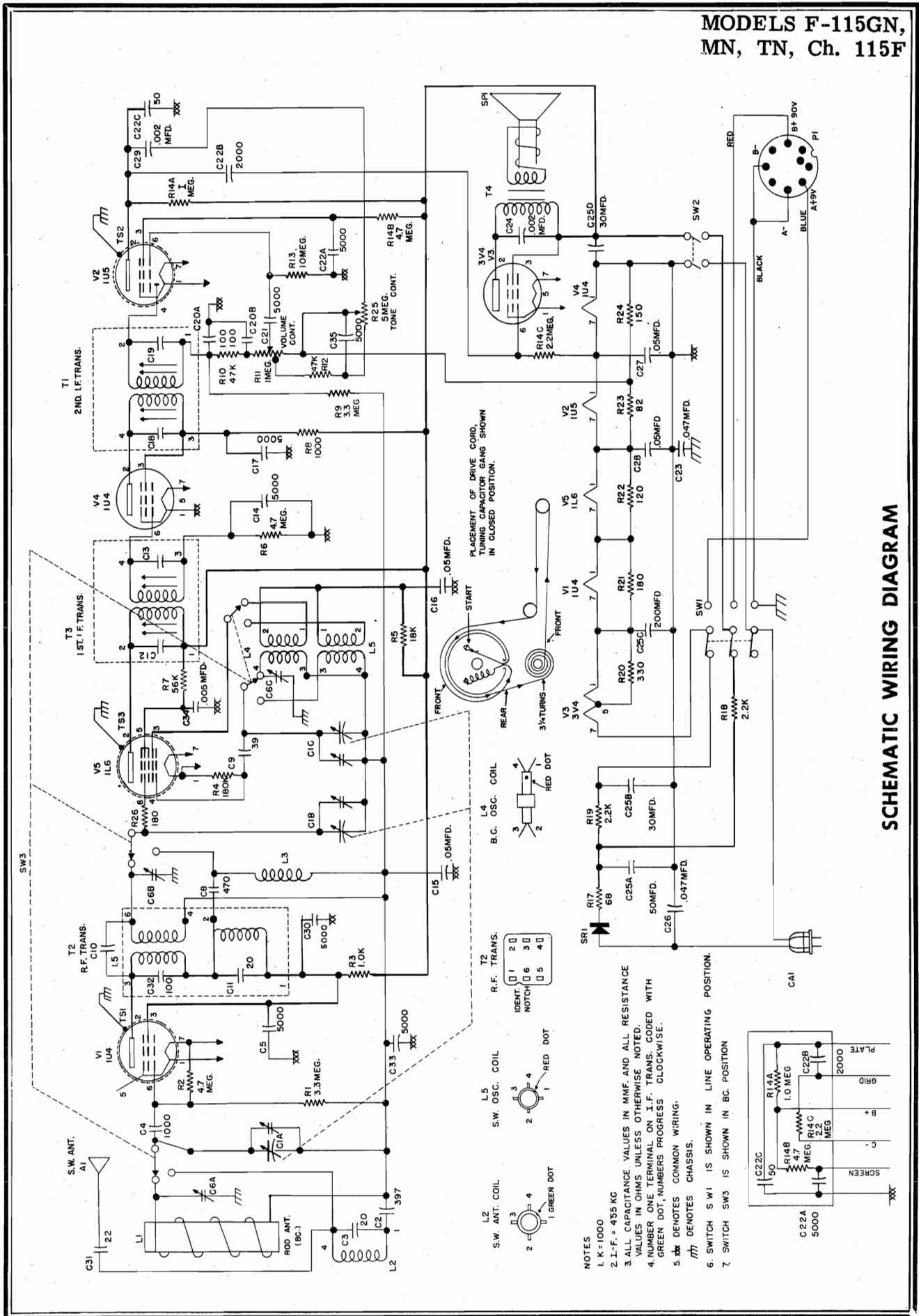

SCHEMATIC WIRING DIAGRAM

MODELS F-115GN,
MN, TN, Ch. 115F

PARTS LIST

Symbol No.	Part No.	Description	Symbol No.	Part No.	Description
C1A	156174-1	Capacitor, Tuning (3-gang) } Assembly	R23	39374-12	Resistor, 82 ohm, 10%, 1/2 w.
C1B		and Short wave Trimmers } Assembly	R24	39374-15	Resistor, 150 ohm, 10%, 1/2 w.
C1C			R25	156307-1	Tone Control (5 megohm)
C2	137499-43	Capacitor, 397 mmf., 2%, 500v., Mica	R26	39374-16	Resistor, 180 ohm, 10%, 1/2 w.
C3	137727-99	Capacitor, 20 mmf., N080, 500v., Ceramic	L1	156533	Rod Antenna (Broadcast)
C4	137727-142	Capacitor, 1000 mmf., 300v., Ceramic	L2	156653-1	Antenna Coil (Short-wave)
C5	137727-121	Capacitor, 5000 mmf, 500v., Ceramic	L3	156714	R.F. Choke
C6A	156491-1	Trimmer (Broadcast), 2-18 mmf.	L4	156691-1	Oscillator Coil (Broadcast)
C6B		Trimmer (Broadcast), 1-8 mmf.	L5	156655-1	Oscillator Coil (Short-wave)
C6C		Trimmer (Broadcast), 2-18 mmf.	A1	156390-1	Telescopic Antenna
C8	137499-46	Capacitor, 470 mmf., 2%, 500v., Mica	P1	156689	Plug (Battery) and Cable
C9	152999-2	Capacitor, 39 mmf., N5600, 300v.	T1	145025-7	Transformer, 2nd I.F.
C10	137398-3	Capacitor, 1.5 mmf., 500v., Disc Ceramic	T2	156756-1	Transformer, R.F.
C11	137727-99	Capacitor, 20 mmf., N080, 500v., Ceramic	T3	145025-8	Transformer, 1st I.F.
C12	Part of T3	Capacitor, 47 mmf.	T4	156321-1	Transformer, Audio Output
C13	Part of T3	Capacitor, 62 mmf.	SR1	156366-1	Selenium Rectifier, 75 ma.
C14	137727-121	Capacitor, 5000 mmf., 500v., Ceramic	SP1	156420	Speaker 5" PM
C15	39001-17	Capacitor, .05 mfd., 150v., Paper	CA1	142769-6	Power Cable and Plug
C16	39433-14	Capacitor, .05 mfd., 150v., Paper	SW1	153347-1	Switch, Line-Battery
C17	137727-121	Capacitor, 5000 mmf., 500v., Ceramic	SW2	Part of 156260	Switch, On-Off
C18	Part of T1	Capacitor, 62 mmf.	SW3	156523-1	Switch, Range
C19	Part of T1	Capacitor, 47 mmf.		156745	Battery Pack
C20A	142951-13	Capacitor, 100 mmf., 500v., Resistor (R10)-Capacitor Unit		156285-1	Bracket, Chassis Mounting (R.H.)
C20B		Capacitor, 100 mmf., 500v., Ceramic		156285-2	Bracket, Chassis Mounting (L.H.)
C21	137727-121	Capacitor, 5000 mmf., 500v., Ceramic		156397	Bracket, Telescopic Antenna
C22A	151550-4	Capacitor, 5000 mmf., Couplate		156368-1	Cabinet, Back (Model F-115MN)
C22B		Capacitor, 2000 mmf., Couplate		156368-2	Cabinet, Back (Model F-115GN)
C22C		Capacitor, 50 mmf., Couplate		156368-3	Cabinet, Back (Model F-115TN)
C23	39477-45	Capacitor, .047 mfd., 600v., Molded Paper		156367-1	Cabinet, Front (Model F-115MN)
C24	39433-25	Capacitor, .002 mfd., 400v., Paper		156367-2	Cabinet, Front (Model F-115GN)
C25A	150975-1	Capacitor, 50 mfd., 150v. Electrolytic		156367-3	Cabinet, Front (Model F-115TN)
C25B		Capacitor, 30 mfd., 25v. Electrolytic		145420	Clip (Fuse Type), Cabinet (2 used)
C25C		Capacitor, 200 mfd., 10v. Electrolytic		157055	Dial
C25D		Capacitor, 30 mfd., 100v. Electrolytic		156487	Dial Background
C26	39477-45	Capacitor, .047 mfd., 600v., Molded Paper		156363	Escutcheon
C27	39433-14	Capacitor, .05 mfd., 150v., Paper		131154-1	External Cotter (Dial Drive Shaft)
C28	39433-14	Capacitor, .05 mfd., 150v., Paper		155286-3	Handle
C29	39433-25	Capacitor, .002 mfd., 400v., Paper		156378	Hinge Clip, Cabinet Back (2 used)
C30	137727-121	Capacitor, 5000 mmf., 500v., Ceramic		156379	Hinge Clip, Cabinet Front (2 used)
C31	137727-128	Capacitor, 22 mmf., N080, 500v., Ceramic		156302-1	Knob, Range Switch (Model F-115MN)
C32	137727-139	Capacitor, 100 mmf., 500v., Ceramic		156302-2	Knob, Range Switch (Model F-115GN)
C33	137727-121	Capacitor, .005 mfd., 500v., Ceramic		156302-5	Knob, Range Switch (Model F-115TN)
C34	137727-141	Capacitor, 5000 mmf., 500v., Ceramic		156315-1	Knob, Tone Control (Model F-115MN)
C35	137727-121	Capacitor, 5000 mmf., 500v., Ceramic		156315-2	Knob, Tone Control (Model F-115GN)
R1	39374-73	Resistor, 3.3 megohm, 10%, 1/2 w.		156315-3	Knob, Tone Control (Model F-115TN)
R2	39374-77	Resistor, 4.7 megohm, 10%, 1/2 w.		156302-2	Knob, Volume and Tuning Controls (Model F-115MN)
R3	39374-25	Resistor, 1000 ohm, 10%, 1/2 w.		156302-4	Knob, Volume and Tuning Controls (Model F-115GN)
R4	39374-52	Resistor, 180,000 ohm, 10%, 1/2 w.		156302-6	Knob, Volume and Tuning Controls (Model F-115TN)
R5	39374-40	Resistor, 18,000 ohm, 10%, 1/2 w.		155280	Link, Handle (2 used)
R6	39374-77	Resistor, 4.7 megohm, 10%, 1/2 w.		94704-39	Nut (Push-on), Escutcheon Mounting (4 used)
R7	39374-46	Resistor, 56,000 ohm, 10%, 1/2 w.		94704-45	Nut (Push-on), Speaker Mounting (4 used)
R8	39374-25	Resistor, 1000 ohm, 10%, 1/2 w.		156669	Pin, Telescopic Antenna Bracket
R9	39374-73	Resistor, 3.3 megohm, 10%, 1/2 w.		156724	Plate (Metal) Battery Strap
R10	Part of C20	Resistor, 47,000 ohm		156461	Pointer, Dial
R11	156260	Volume Control (1 megohm, Tapped at 300,000 ohm)		137939-2	Pulley, Idler (2 used)
R12	39374-45	Resistor, 47,000 ohm, 10%, 1/2 w.		137940-1	Rivet, Idler Pulley (2 used)
R13	39374-85	Resistor, 10 megohm, 10%, 1/2 w.		156481	Shaft, Dial Drive
R14A	Part of C22	Resistor, 1 megohm, 1/2 w.		147784	Shield, Tube (V1, V2, V5)
R14B		Resistor, 4.7 megohm, 1/2 w.		148346	Socket, Tube (5 used)
R14C		Resistor, 2.2 megohm, 1/2 w.		156612	Spring, Contact (Receptacle on chassis for line-cord)
R17	39374-187	Resistor, 68 ohm, 10%, 2 w.		145757	Spring, Dial Drive Cord
R18	39374-117	Resistor, 2200 ohm, 10%, 1 w.		157611-1	Spring, Fuse Clip
R19	156643-1	Resistor, 2200 ohm, 3%, 7 w., Wire Wound		156662	Strap, Battery
R20	39374-19	Resistor, 330 ohm, 10%, 1/2 w.		156595	Strip (Fish Paper), Dial Pointer
R21	39374-16	Resistor, 180 ohm, 10%, 1/2 w.		156692	Support and Bracket Assembly (Rod Antenna)
R22	39374-14	Resistor, 120 ohm, 10%, 1/2 w.		156278-1	Support, Handle & Chassis Bracket (R.H.)
				156278-2	Support, Handle & Chassis Bracket (L.H.)
				156684	Support and Terminal Assembly (Rod Antenna)
				155308-2	Washer, Felt (3 used)
				134916	Washer (Spring), Dial Drive Shaft

100-125V A.C. 60 CYCLES ONLY

The DeWald Model F-523 is a combination self-starting electric clock and super-heterodyne receiver. The receiver can automatically be turned on or off by the clock. The receiver range is from 525 to 1700 kilocycles.

NOTE: The receiver and clock operate on 105-125 volts 60 cycles A.C. ONLY! Your local Power Company will help you make certain that you have the correct power.

CONTROLS

1. The left-hand knob on the receiver is the volume control.
2. The right-hand knob on the receiver is the station selector.
3. The "Radio Switch" knob is located at the nine o'clock position of the clock.
4. The "Sleep Switch" knob is located at the six o'clock position.
5. The "Alarm Set" knob is located at the three o'clock position.

OPERATION

Your self-starting Telechron clock will start automatically when the set is plugged into the proper outlet. Set the correct time by means of the small knob at the right REAR of the cabinet. Turn ONLY in the direction shown on the back cover.

A. TO TURN RADIO ON MANUALLY:

Turn "Radio Switch" knob to "On" position. Be sure that the line cord is plugged in. Allow approximately one minute for the tubes to heat up. The receiver is then ready for operation. Select the desired station by turning the station selector knob and adjust the volume to the desired level.

B. TO TURN RADIO OFF MANUALLY:

Turn "Radio Switch" knob to the "Off" position.

C. TO TURN RADIO ON AUTOMATICALLY:

Pull out "Alarm Switch" knob and turn in counter-clockwise (arrow) direction until pointer is over hour figure and minute marks desired. After setting the desired time, push in the "Alarm Set" knob. Turn the radio "On" and set to the station and volume desired. (See "A" above). Then turn the "Radio Switch" knob to the "Auto" position. This operation turns the radio off, but it will automatically turn on again at the time set.

D. TO TURN RADIO OFF AUTOMATICALLY:

While the radio is playing, turn the "Sleep Switch" knob clockwise for playing time desired. Estimate time in minutes between 0 and 60 marks along arrow.

Set "Radio Switch" knob to the "Off" position. Radio will continue playing, but will turn off automatically at the pre-set time.

E. TO TURN ON BUZZER ALARM WITH RADIO SILENCED:

Turn "Radio Switch" knob to "Off" position. Pull out "Alarm Switch" knob and turn in counter-clockwise (arrow) direction until the pointer is set ten minutes ahead of the hour figure and minute marks desired. For example: Should you desire the buzzer to sound at 7, set alarm pointer to 6:50. To shut off the buzzer, push in the "Alarm Set" knob.

F. TO TURN RADIO AND BUZZER ON AUTOMATICALLY:

Follow procedure as outlined under "C" above, with the exception that having set the desired time, do not push in the "Alarm Set" knob. Buzzer sounds approximately 10 minutes after the radio comes on. To shut off the buzzer, push in the "Alarm Set" knob. The radio will continue to play until the "Radio Switch" knob is turned to the "Off" position.

G. TO TURN RADIO OFF AUTOMATICALLY, THEN ON AGAIN AUTOMATICALLY, WITH BUZZER OFF:

Adjust the "Sleep Switch" knob as described in "D" above, but set the "Radio Switch" knob to the "Auto" position. Set the "Alarm Switch" knob as described in paragraph "C". The radio will continue playing for the amount of time set on the "Sleep Switch" and then shut off, but will come on again automatically at the pre-set time. *NOTE: Make sure that the "Alarm Set" knob is pushed in.*

H. TO TURN RADIO OFF AUTOMATICALLY, THEN ON AGAIN AUTOMATICALLY, WITH BUZZER ON:

Follow the procedure outlined in "G" above, but make sure that the "Alarm Set" knob is pulled out. The buzzer will then sound approximately ten minutes after the radio goes on.

I. TO TURN THE RADIO OFF AUTOMATICALLY, THEN TURN THE BUZZER ALARM ON:

Follow the instructions given in paragraphs "D" and "E".

ANTENNA

The "Looptenna" incorporated in the DeWald Model F-523 receiver makes use of an outside antenna unnecessary in most localities. If additional pick-up is desired, connect an external antenna to the flexible lead which is brought out of the rear of the cabinet for this purpose. The "Looptenna" has a directional effect and therefore it may be necessary to change the angle of the receiver for the best reception.

MODEL G-404

This model is a four tube superheterodyne receiver with full automatic volume control. A Loop Antenna coil is used with this receiver and is designed to pick up strong local stations without requiring an outside Antenna. An external Antenna is recommended; connect to external lead for additional signal pick up. The range coverage is 535-1700 Kilocycles. The receiver has been designed to operate at 105-125 volts, 40-60 cycles A. C. - D. C. unless otherwise specified.

OPERATION:

Insert the receiver line cord plug in electric outlet. Turn lower right knob in a clockwise direction. Allow approximately one minute for the tubes to heat up and receiver is then ready for operation.

NOTE:

If the receiver is being operated on D.C. and no signals are heard after it has been turned "on" for one minute, reverse the line plug.

Volume Control:

The lower knob of the receiver is used as the power switch and volume control. Rotation of this knob in a clockwise direction turns the receiver "on". Further rotation in this direction increases the volume.

STATION SELECTOR:

The upper knob operates the tuning in of stations.

1142	Loop	3029	½ W. Resistors
1141	Oscillator Coil	3001A	2 W. Resistors
1091B-9	I.F. Coil	3043	Vol. Cont. and Switch
2000A	Paper Condensers	5010-4	Line Cord
2063	Ceramic Condensers	7003C-5	Speaker
2033	Comb. Electrolytic	4180	Cabinet Back
2065-2	Var. Condenser		

	TUBES	IVORY CABINET	4181-1
1	35W4	WALNUT CABINET	4181-2
1	50C5		
1	12AT6	IVORY TUNING KNOB	4178-1
1	12AU6	WALNUT TUNING KNOB	4178-2
		IVORY VOLUME KNOB	4179-1
		WALNUT VOLUME KNOB	4179-2

MODEL G-404
SUPERHETERODYNE AC/DC
RANGE: 535-1700 KILOCYCLES
VOLTS CYCLES WATTS
105-120 40-60 25
 OR D.C.

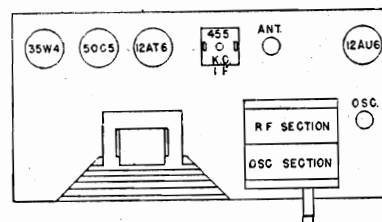

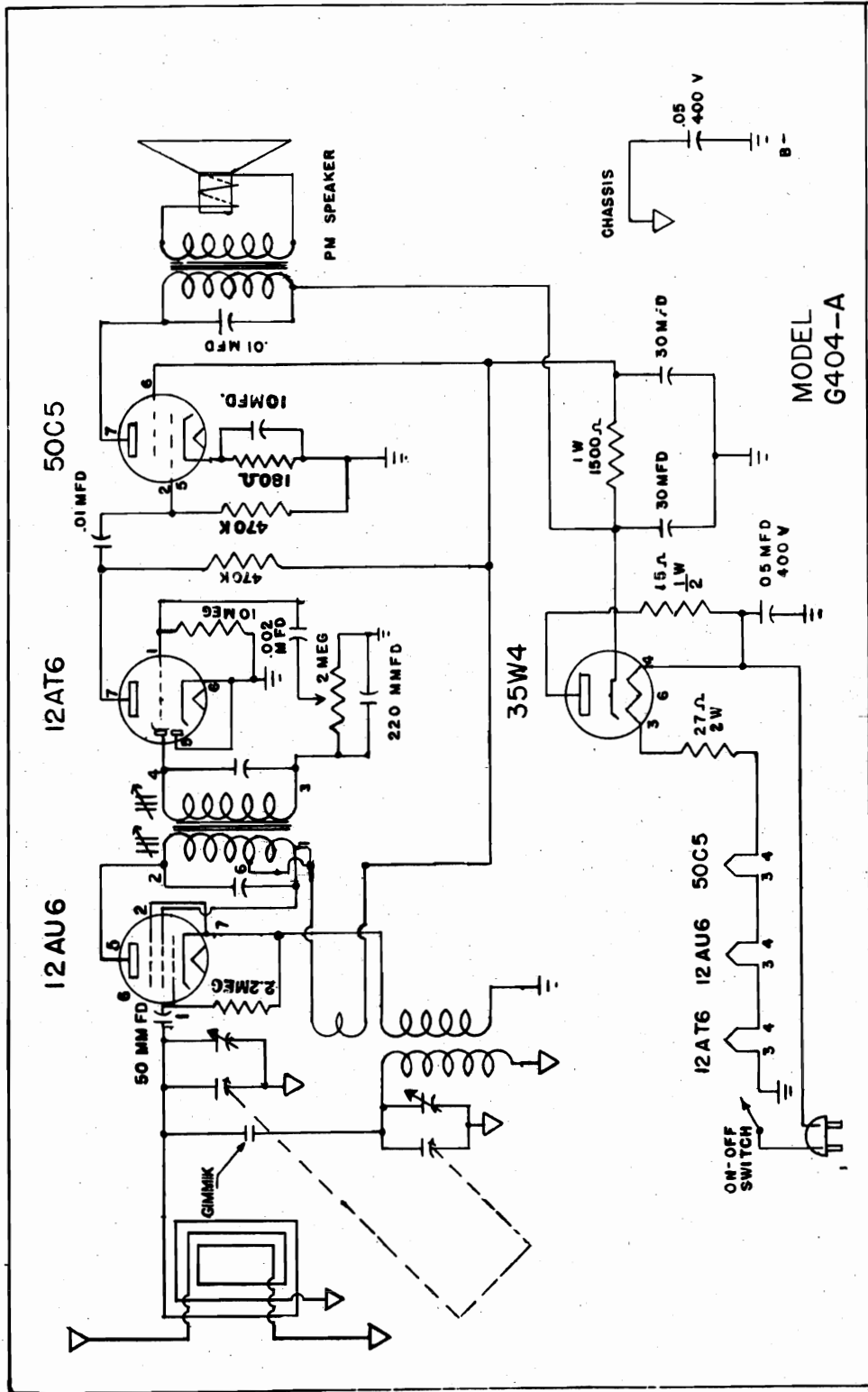

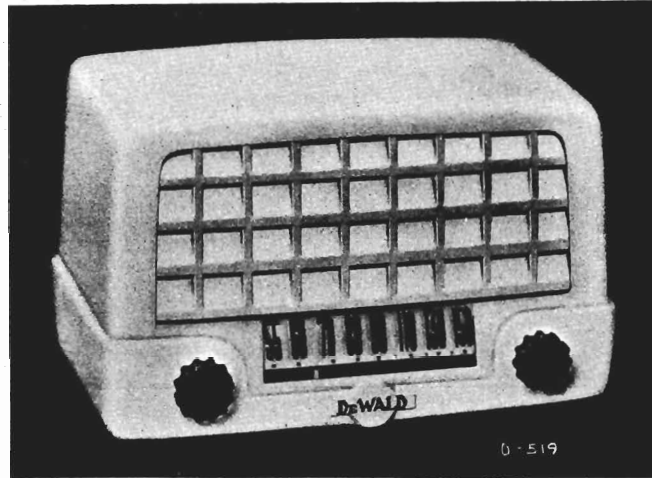

This model is a five tube superheterodyne receiver with full automatic volume control. A self-contained loop tenna is incorporated which makes the use of an antenna unnecessary. The range coverage is 525-1720 kilocycles. The receiver has been designed to operate at 105-125 volts, 40-60 cycles A.C. -D.C. unless otherwise specified.

OPERATION:

Insert the receiver line cord plug in electric outlet. Turn left knob in a clockwise direction. Allow approximately one minute for the tubes to heat up and receiver is then ready for operation.

NOTE:

If the receiver is being operated on D.C. and no signals are heard after it has been turned "on" for one minute, reverse the line plug.

ANTENNA:

The receiver operates satisfactorily without an antenna. If additional pick-up is desired, an antenna may be connected by following instructions on cabinet back.

VOLUME CONTROL:

The left knob of the receiver is used as the power switch and volume control. Rotation of this knob in a clockwise direction turns the receiver "on". Further rotation in this direction increases the volume.

STATION SELECTOR:

The right hand knob operates the tuning in of stations and pointer. Ease and accuracy in tuning is provided because of a reduction drive.

IMPORTANT:

Since the "looptenna" used has a directional effect, it may be found necessary to change the angle of the receiver.

1045	Looptenna	3000	1/4 W. resistors
1028	oscillator coil	3001	2 W. resistors
10918	1st I.F. coil	3002	vol. cont. and switch
10918	2nd detector coil	5000	line cord
2000A	paper condensers	7003	speaker
ceramic 2012B	condensers	9050	shaft
2033	comb. electrolytic	9818	bushing
20178	var. condenser	9762	drive spring
		#20	dial cord

TUBES

1	35W4
1	50B5
1	12AT6
1	12BA6
1	12BE6

CABINET	4053
KNOB	4055A
BACK	4059

VOLTAGE CHART

Tube No.	Pin 1	Pin 2	Pin 3	Pin 4	Pin 5	Pin 6	Pin 7
V1	-10V	0	10V	22V	+80V	+80	-1
V2	-1.1V	0	32V	20V	+80V	+80	0
V3	-0.7V	0	0	10V	-0.5V	0	+30
V4	0	+4.5V	32V	78V	+110V	+80	
V5			75V	117V	117VAC		+110V

All measurements with respect to chassis use Precision VTVM.

RESISTANCE CHART

Tube No.	Pin 1	Pin 2	Pin 3	Pin 4	Pin 5	Pin 6	Pin 7
V1	24K	0.6	14 Ω	20 Ω	50K	50K	3 meg
V2	3meg	0	30 Ω	20 Ω	400K	300K	0
V3	4.7meg	0	0	12 Ω	400K	0	700K
V4	500K	150 Ω	30 Ω	80 Ω	400K	300K	NC
V5	NC	NC	80 Ω	110 Ω	110 Ω	NC	500K

All measurements with respect to chassis use Triplet VTVM Model 650

RESISTORS

R1	22K Ω
R2	100 Ω
R3	2.2 meg
R4	4.7 meg
R5	1/2 meg Vol. Control
R6	470K Ω
R7	470K Ω
R8	150 Ω
R9	1500 Ω

COILS AND TRANSFORMERS

T ₁ , T ₂	I. F. Coil
T ₃	Audio Output Transformer

CAPACITORS

C1A, B	Variable Condenser
C2, C3	Trimmer
C4	.05mf 200V
C5	220mmf
C6	.005mf
C7	100mmf
C8	.01mf
C9	.02mf 400V
C10A, B	30mf 150V
C11	.05mf 400V

MODELS 602A, Ch. 120072A; 602B, Ch. 120072B; 602C, Ch. 120102A

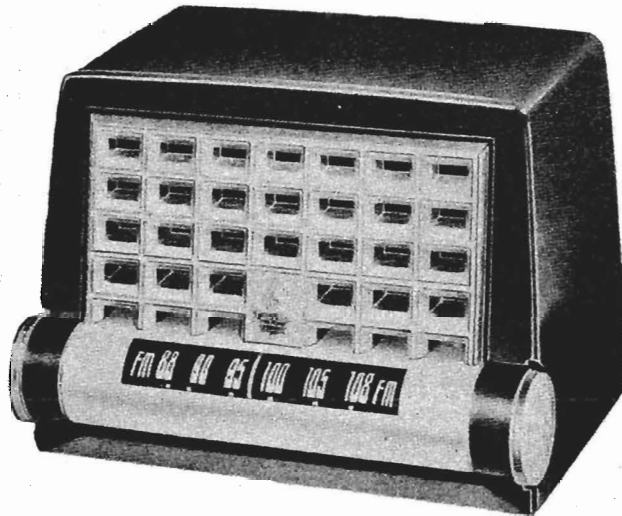

DESCRIPTION

TYPE: Single band (FM) superheterodyne

FREQUENCY RANGE: 88-108 mc.

INTERMEDIATE FREQUENCY: 10.7 mc.

TYPE OF TUBES:

- 1—6BJ6, Δ r-f amplifier
- 1—12BA7, converter
- 1—12BA6, first i-f amplifier
- 1—12BA6 or 6BJ6, Δ second i-f amplifier
- 1—12S8G1, ratio detector, a.v.c., a-f amplifier
- 1—35B5, power output
- 1—35W4, rectifier

POWER SUPPLY: A.c. or d.c.

VOLTAGE RATING: 105-125 volts

POWER CONSUMPTION: 30 watts

CURRENT DRAIN: .25 amp. at 117 volts a.c.

Δ Chassis 120102A only.

GENERAL NOTES

1. If replacements are made or the wiring disturbed in the r-f section of the circuit, the receiver should be carefully realigned. The position of tuned circuit components and connecting leads is critical. Carefully dress all leads after part replacement to correspond to the original position.
2. For operation on d.c. it may be necessary to reverse the line plug for proper polarity.
3. The color coding of the output transformer leads is as follows:
 Plate—blue
 Rectifier cathode—red
4. An internal power line antenna is provided for FM reception in relatively strong signal areas. The line cord should be completely uncoiled for effective operation of this antenna. An external dipole antenna is recommended for maximum FM operation. To connect the dipole, remove the wire from the screw terminal at the rear of the chassis marked "A" and connect the dipole leads to "A" and "G".
5. A ground connection is not required for operation of this receiver.

ALIGNMENT PROCEDURE

1. To position pointer, turn variable condenser fully closed and set pointer to reference mark at low-frequency end of dial.
2. Volume control should be set at maximum position; output of signal generator should be no higher than necessary to obtain an output reading. Use an insulated alignment tool for all adjustments.
3. For step 2 in alignment with AM signal generator, connect two 100 K resistors in series from point "B" to ground.
4. For alignment with FM signal generator, use frequency modulated signal with 60-cycle modulation and 450 KC sweep. Use 120 cycle sweep voltage in scope for horizontal deflection.

RATIO DETECTOR AND IF ALIGNMENT USING AM SIGNAL GENERATOR AND VTVM

	DUMMY ANTENNA	SIGNAL GENERATOR COUPLING	SIGNAL GENERATOR FREQUENCY	RADIO DIAL SETTING	CONNECT VTVM	ADJUST	REMARKS
1	.005 mfd.	High side to pin 1 (grid) of V3, second i-f. Low side to chassis.	10.7 MC (Unmodulated).	Tuning cond. fully open.	Connect d.c. probe to point "B". Common to chassis.	A2 (Bottom of ratio det. trans. T3).	Adjust for maximum output.
2	.005 mfd.	"	"	"	Connect d.c. probe to point "A". Common to junction of two 100 K resistors connected between "B" and chassis. See Note 3.	A1 (Top of ratio det. trans. T3).	Adjust for minimum output.
3	.005 mfd.	High side to pin 2 (osc. grid) of V1, converter. Low side to chassis. Disconnect internal antenna lead from term. strip.	"	"	Connect d.c. probe to point "B". Common to chassis.	A3, A4 (2nd i-f trans. T2).	Adjust for maximum output.
4	.005 mfd.	"	"	"	"	A5, A6 (1st i-f trans. T1).	Adjust for maximum output. Continue with r-f alignment.

RATIO DETECTOR AND IF ALIGNMENT USING FM SIGNAL GENERATOR AND SCOPE

	DUMMY ANTENNA	SIGNAL GENERATOR COUPLING	SIGNAL GENERATOR FREQUENCY	RADIO DIAL SETTING	CONNECT SCOPE	ADJUST	REMARKS
1	.005 mfd.	High side to pin 1 (grid) of V3, second i-f Low side to chassis.	10.7 MC (450 KC. sweep).	Tuning cond. fully open.	Vertical input through 10 K resistor to point "A". Common to chassis.	A2, A1 (Ratio det. trans. T3).	Adjust A2 for max. amplitude and linearity of double "S"-shaped response curve. Adjust A1 to move cross-over point to center of pattern (equal sections above and below intersection).
2	.005 mfd.	High side to pin 2 osc. grid of V1, converter. Low side to chassis. Disconnect internal antenna lead from term. strip.	"	"	Vertical input across voice coil.	A3, A4, A5, A6 (2nd & 1st i-f trans. T2 & T1).	Adjust for maximum amplitude and symmetry of sine wave output. Continue with r.f. alignment.

MODELS 602A, Ch. 120072A; 602B,
Ch. 120072B; 602C, Ch. 120102A RF ALIGNMENT

	ANTENNA DUMMY	SIGNAL GENERATOR COUPLING	SIGNAL GENERATOR FREQUENCY	RADIO DIAL SETTING	CONNECT VTVM	ADJUST	REMARKS
1	150 ohm resistor in series with each gen. lead.	High side to term. "A"; low side to term. "G" at rear of chassis.	108.0 MC (Unmodulated).	Tuning cond. fully open. (108.0 MC).	Connect d.c. probe to "B". Common to chassis.	A7 (Trimmer cond. C4).	Adjust for maximum output.
2	"	"	106.0 MC.	Tune for maximum deflection.	"	A8 (Trimmer cond. C3).	"

INSTRUCTIONS FOR VOLTAGE AND RESISTANCE READINGS

1. Voltage readings are in volts and resistance readings in ohms unless otherwise specified.
2. All measurements made with voltohmmyst.
3. Socket connections are shown as bottom views.
4. Measured values are from socket pin to common negative, unless otherwise specified.
5. Line voltage maintained at 117 volts for voltage readings.
6. Nominal tolerance on component values makes possible a variation of $\pm 15\%$ in voltage and resistance readings.
7. Volume control at maximum, no signal applied, for voltage measurements.

VOLTAGE READINGS

SYMBOL	TUBE TYPE	PIN 1	PIN 2	PIN 3	PIN 4	PIN 5	PIN 6	PIN 7
V1	12BA7	98	-3.8	0	{38 AC {43 ACΔ	{50 AC {31 ACΔ	0	0
V2	12BA6	-.8	0	{26AC {19ACΔ	{38 AC {31 ACΔ	92	92	0
V3	12BA6 or 6BJ6Δ	-.8	0	{26AC {19ACΔ	13 AC	92	92	0
V4	12S8GT	-.5	0	-.5	0	-.5	50	13 AC
V5	35B5	0	5.7	50 AC	82 AC	110	92	NC
V6	35W4	NC	0	82 AC	117 AC	115 AC	NC	116
V7	6BJ6Δ	0	.8	43 AC	49 AC	92	92	0

RESISTANCE READINGS

SYMBOL	TUBE TYPE	PIN 1	PIN 2	PIN 3	PIN 4	PIN 5	PIN 6	PIN 7
V1	12BA7	1K*	22K	0	{38 {48Δ	{50 {34Δ	0	0
V2	12BA6	2.2 Meg.	0	{25 {21Δ	{38 {34Δ	1000*	1000*	0
V3	12BA6 or 6BJ6Δ	2.2 Meg.	0	{25 {21Δ	15	1100*	1100*	0
V4	12S8GT	620K	0	32K	0	620K	550K*	15
V5	35B5	470K	180	{50 {54Δ	86	160	1000*	NC
V6	35W4	NC	0	86	124	{164 {146Δ	NC	0*
V7	6BJ6Δ	0	70	48	54	1000*	1000*	0

SYMBOL	TUBE TYPE	VOLTAGE		RESISTANCE	
		PIN 8	PIN 9 or CAP	PIN 8	PIN 9 or CAP
V1	12BA7	0	98	0	1000*
V4	12S8GT	0	-1.3	0	4 Meg.

* Measured to Pin 7 of V6, 35W4
NC=no connection;
K=Kilohm;
Meg.=megohm.
Δ Chassis 120102A only.

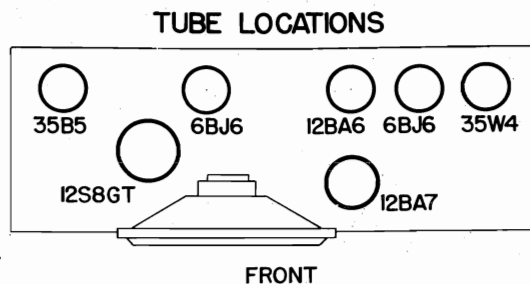
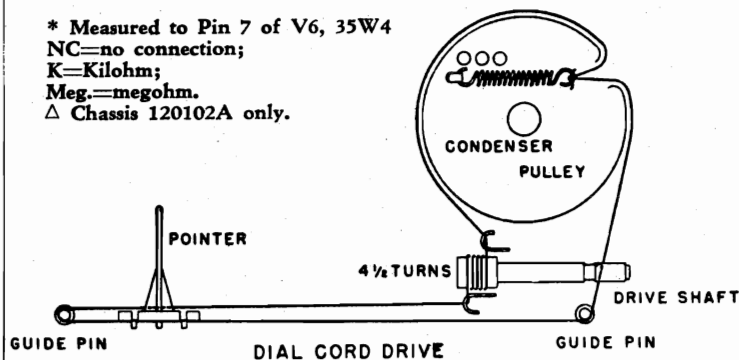

MODELS 602A, Ch. 120072A;
602B, Ch. 120072B; 602C, Ch.
120102A

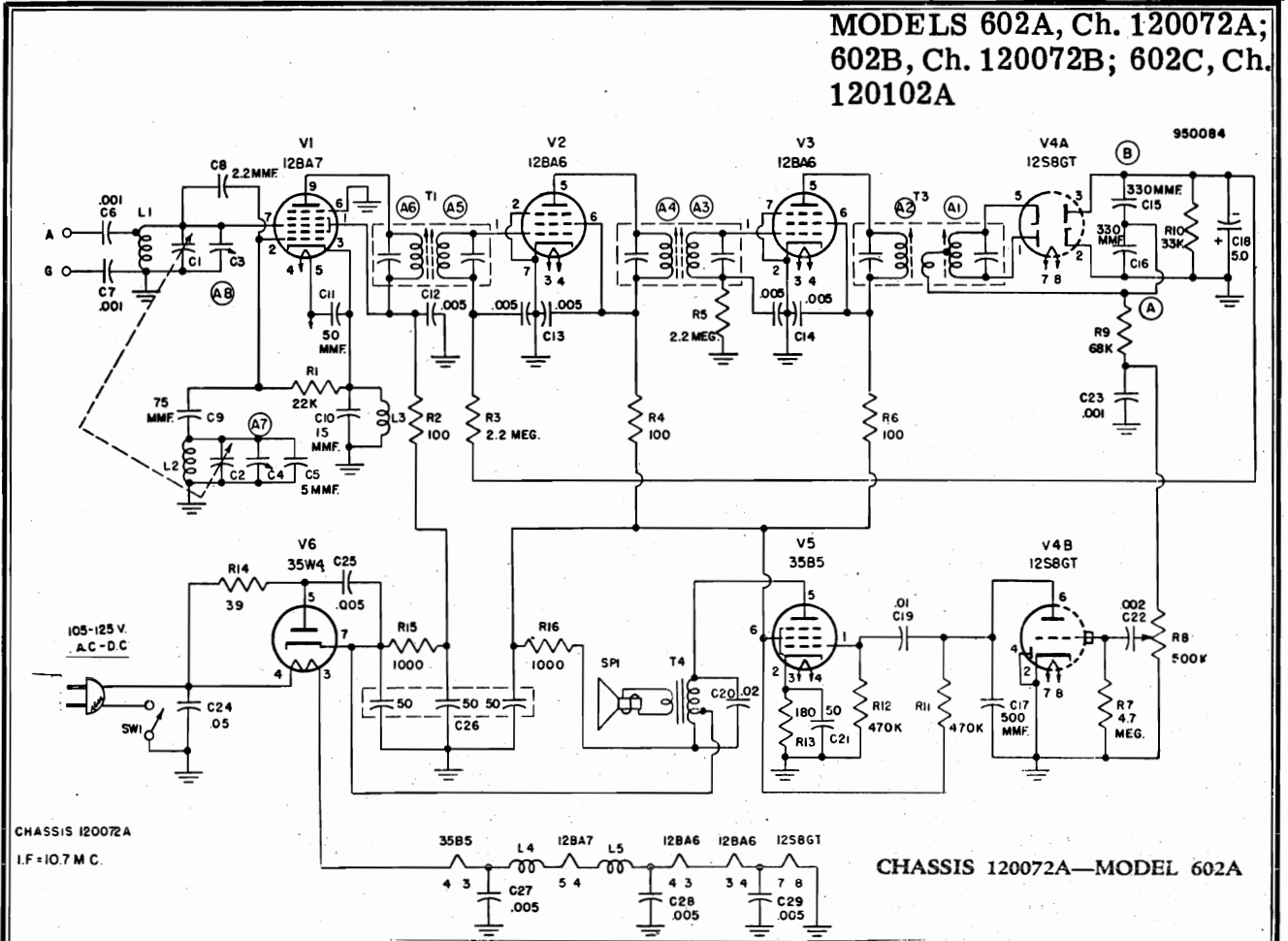

CHASSIS 120072A
IF=10.7 MC.

CHASSIS 120072A—MODEL 602A

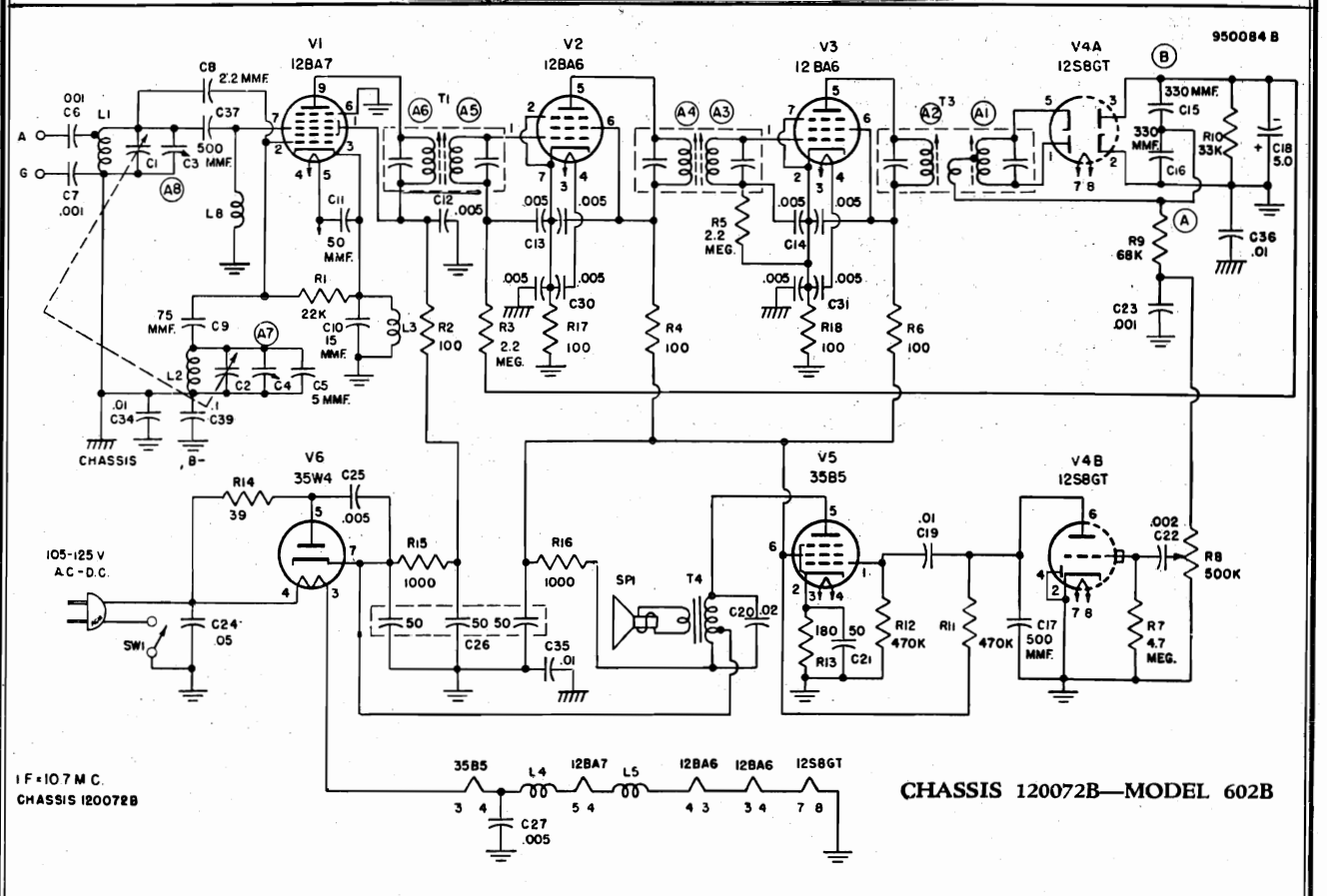

IF=10.7 MC.
CHASSIS 120072B

CHASSIS 120072B—MODEL 602B

MODELS 602A, Ch. 120072A; 602B, Ch. 120072B; 602C, Ch. 120102A

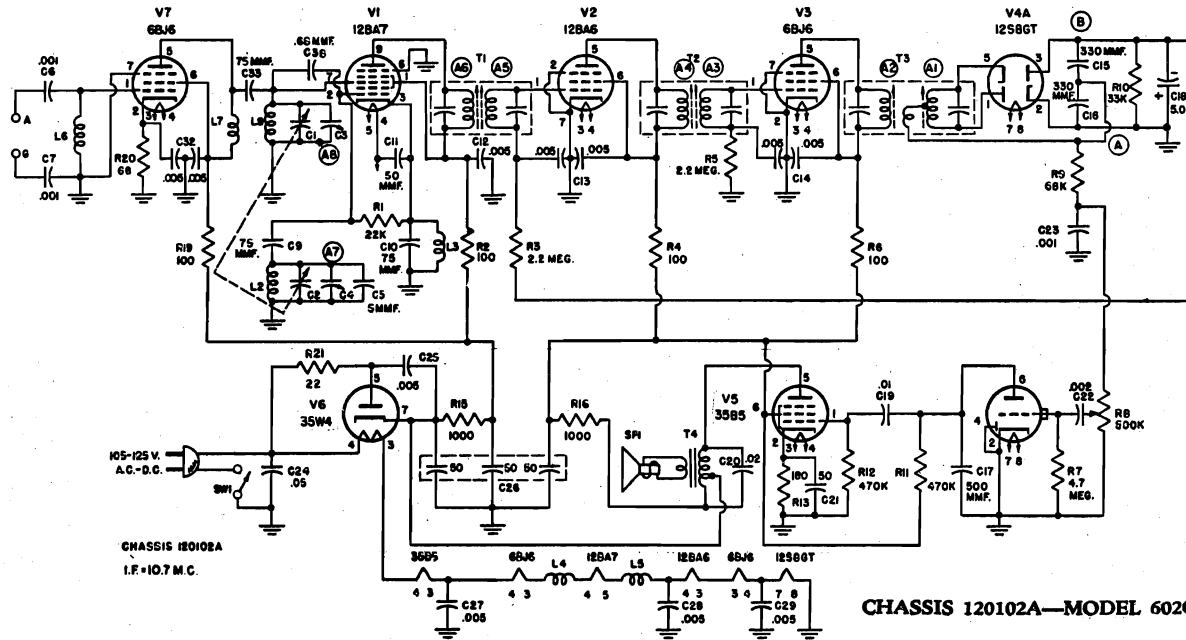

CHASSIS 120102A—MODEL 602C

Symbol	†Part No.	DESCRIPTION	Symbol	†Part No.	DESCRIPTION
V1	12BA7	Converter	C37	928004#	500 mmf., ceramic
V2	12BA6	First i-f amplifier	C38	915040Δ	.68 mmf., molded
V3	12BA6 or 6BJ6Δ	Second i-f amplifier	C39	920250#	.1 mfd., 400 volt, paper
V4	12S8GT	Ratio det., a.v.c., a-f amplifier	L1	710018*#	Antenna coil
V5	35B5	Power output	L2	716028	Oscillator coil
V6	35W4	Rectifier	L3	705002	R-f choke, oscillator
V7	6BJ6Δ	R-f amplifier	L4	705002	R-f choke, heater
C1	900041	Two-gang, variable condenser	L5	705002	R-f choke, heater
C2			L6	710019Δ	Antenna coil
C3	Part of C1, C2	Trimmers, r-f and osc.	L7	705002Δ	R-f choke
C4			L8	705002	R-f choke
C5	928029	5 mmf., temp. comp.	L9	716028Δ	R-f coil
C6	928003	.001 mfd., ceramic	R1	340810	22 kilohms, 1/2 watt
C7	928003	.001 mfd., ceramic	R2	340250	100 ohms, 1/2 watt
C8	915005	2.2 mmf., molded	R3	351290	2.2 megohms, 1/2 watt
C9	928015	75 mmf., ceramic	R4	340250	100 ohms, 1/2 watt
C10	928025	15 mmf., ceramic	R5	351290	2.2 megohms, 1/2 watt
C11	928014	50 mmf., ceramic	R6	340250	100 ohms, 1/2 watt
C12	928109	.005 mfd., ceramic	R7	351370	4.7 megohms, 1/2 watt
C13	928022.	4700-4700 mmf., ceramic	R8	390062	500 kilohms, volume control
C14	928022	4700-4700 mmf., ceramic	R9	340930	58 kilohms, 1/2 watt
C15	910026	330 mmf., mica	R10	340850	33 kilohms, 1/2 watt
C16	910026	330 mmf., mica	R11	351130	470 kilohms, 1/2 watt
C17	928004	500 mmf., ceramic	R12	351130	470 kilohms, 1/2 watt
C18	925116	5 mfd., 25 volt, elect.	R13	340310	180 ohms, 1/2 watt
C19	920090	.01 mfd., 400 volt, paper	R14	370150	39 ohms, 1 watt
C20	920020	.02 mfd., 400 volt, paper	R15	340490	1000 ohms, 1/2 watt
C21	925117	50 mfd., 25 volt, electrolytic	R16	370490	1000 ohms, 1 watt
C22	920010	.002 mfd., 600 volt, paper	R17	340250	100 ohms, 1/2 watt
C23	928003	.001 mfd., ceramic	R18	340250	100 ohms, 1/2 watt
C24	920030	.05 mfd., 400 volt, paper	R19	340250	100 ohms, 1/2 watt
C25	928109	.005 mfd., ceramic	R20	340210	68 ohms, 1/2 watt
C26	{925118*Δ 925118#	50-50-50 mfd., 150 volt, electrolytic	R21	370090	22 ohms, 1 watt
C27	928109	.005 mfd., ceramic	T1	720067	First i-f transformer (Alt. parts 720024, 720082)°
C28	928109*Δ	.005 mfd., ceramic	T2	720067	Second i.f. transformer (Alt. parts 720024, 720082)°
C29	928109*Δ	.005 mfd., ceramic	T3	720071	Ratio detector transformer (Alt. parts 720068, 720072)°
C30	928022#	4700-4700 mmf., ceramic	T4	734044	Output transformer
C31	928022#	4700-4700 mmf., ceramic	SW1	Part of R8	Line switch
C32	928022Δ	4700-4700 mmf., ceramic	SP1	180055	P.M. speaker
C33	928015Δ	75 mmf., ceramic		{583205 583205A#	Line cord and internal ant.
C34	928027#	.01 mfd., ceramic (button type)			
C35	928027#	.01 mfd., ceramic (button type)			
C36	928027#	.01 mfd., ceramic (button type)			

° Replace with part having same number, † Specify part numbers when ordering.

* Chassis 120072A only

Δ Chassis 120102A only. # Chassis 120072B only.

CABINET AND DIAL PARTS

†Part No.	DESCRIPTION	†Part No.	DESCRIPTION
140168	Cabinet, maroon plastic	460088	Knob, plastic
460078	Speaker grille	530002	Dial cord (31")
520068	Dial backplate	280055	Drive shaft
525033	Pointer	587040	Dial drive spring

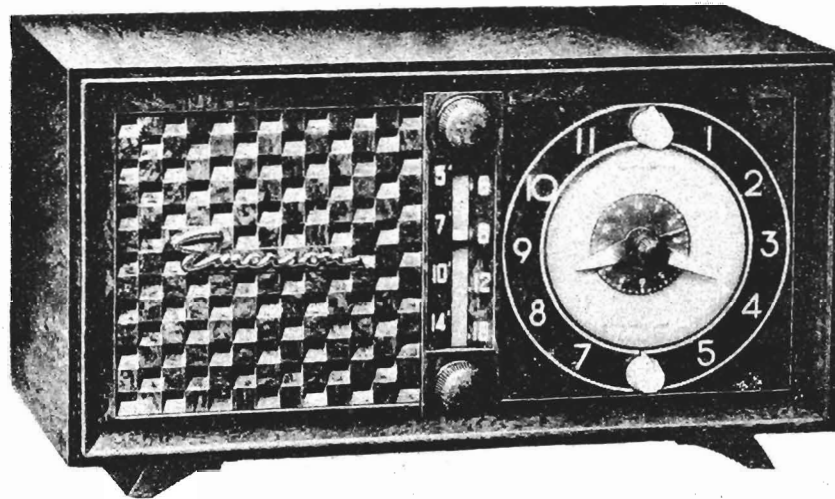
MODEL 695B,
Ch. 120146-BMODEL 695B
CHASSIS 120146-B

DESCRIPTION

TYPE: Single-band superheterodyne, with clock-timer and appliance outlet.

FREQUENCY RANGE: 540-1620 kc.

TYPE OF TUBES:

- V-1—12BE6, oscillator mixer
- V-2—12BA6, first i-f amplifier
- V-3—12AT6, detector, a-f amplifier
- V-4—50C5, A. F. output
- V-5—35W4, rectifier

POWER SUPPLY: A.C. 60 cycles only

VOLTAGE RATING: 115 volts.

POWER CONSUMPTION: 32 watts.

GENERAL NOTES

1. If replacements are made or the wiring disturbed in the r-f section of the circuit, the receiver should be carefully realigned.
2. This model has a self-contained antenna and does not require additional antenna connections. For permanent home installations, however, if it is desired to improve reception of weak stations, an additional outdoor antenna may be used. For this purpose a lead has been brought out in the rear. Use no ground connection.
3. The self-contained loop antenna operates at maximum efficiency when its position is at right angles to the broadcasting source. It is important, therefore, once the station is tuned in, to rotate the cabinet back and forth through a quarter of a circle (90 degrees), leaving it at the position where the station is received with maximum volume.
4. Appliance outlet and radio on-off switch located in back of chassis. For information on clock applications see instructions supplied with set.

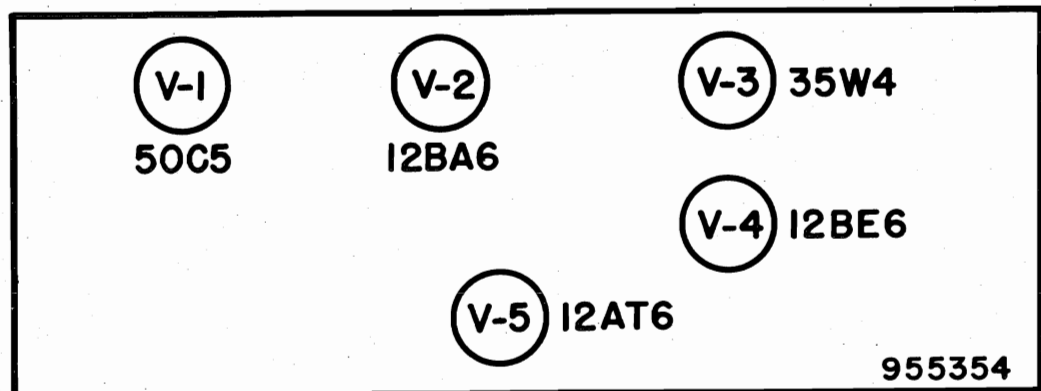

Fig 3. TUBE LOCATION DIAGRAM OF CHASSIS 120146-B

MODEL 695B,
Ch. 120146-B

ALIGNMENT

To set pointer, turn variable condenser fully closed and set pointer at mark near top end of dial backplate. Use isolation transformer if available. If not, connect a 0.1 mfd. condenser in series with low side signal generator and chassis. Volume control should be at maximum position; output of signal generator should be no higher than necessary to obtain an output reading. Use an insulated alignment screwdriver for adjusting.

	DUMMY ANTENNA	SIGNAL GENERATOR COUPLING	SIGNAL GENERATOR FREQUENCY	RADIO DIAL SETTING	METER OUTPUT	ADJUST	REMARKS
1	0.001 mfd.	High side to stator of rear section of tuning condenser. Low side to chassis.	455 kc	Variable condenser fully open.	Across voice coil.	A1, A2, A3, A4	Adjust for maximum output.
2	200 mmfd.	High side to external antenna lead. Low side to external ground lead.	1620 kc	Variable condenser fully open.	Across voice coil.	A5	Adjust for maximum output.
3	200 mmfd.	High side to external antenna lead. Low side to external ground lead.	1400 kc	Tune for maximum output.	Across voice coil.	A6	Adjust for maximum output.

VOLTAGE READING FOR CHASSIS 120146-B

SYMBOL	TUBE	PIN 1	PIN 2	PIN 3	PIN 4	PIN 5	PIN 6	PIN 7
V-1	12BE6	-6.3 DC	0	24 AC	12 AC	90 DC	90 DC	-0.8 DC
V-2	12BA6	-0.8 DC	0	24 AC	36 AC	90 DC	90 DC	1 DC
V-3	12AT6	-0.9 DC	0	0	12 AC	-0.8 DC	-0.8 DC	38 DC
V-4	50C5	5.5 DC	0	80 AC	36 AC	0	90 DC	110 DC
V-5	35W4	0	0	80 AC	117 AC	115 AC	110 AC	120 DC

RESISTANCE READING FOR CHASSIS 120146B

SYMBOL	TUBE	PIN 1	PIN 2	PIN 3	PIN 4	PIN 5	PIN 6	PIN 7
V-1	12BE6	2,400	0.4	26	14	300,000	300,000	4 meg.
V-2	12BA6	4 meg.	0	26	38	300,000	300,000	120
V-3	12AT6	10 meg.	0	0	14	500,000	4 meg.	800,000
V-4	50C5	150	470,000	90	38	470,000	300,000	350,000
V-5	35W4	N.C.	N.C.	90	125	150	120	350,000

VOLTAGE AND RESISTANCE READING INSTRUCTIONS

1. Voltage readings are in volts and resistance readings in ohms unless otherwise specified.
2. D-C voltage measurements are at 20,000 ohms per volt; a-c voltage measured at 1,000 ohms per volt.
3. Measured values are from socket pin to common negative.
4. Line voltage maintained at 117 volts, 60 cycles for voltage readings.
5. Normal tolerance on component values makes possible a variation of $\pm 15\%$ in voltage and resistance readings.
6. Volume control at maximum, no signal applied for voltage measurements.

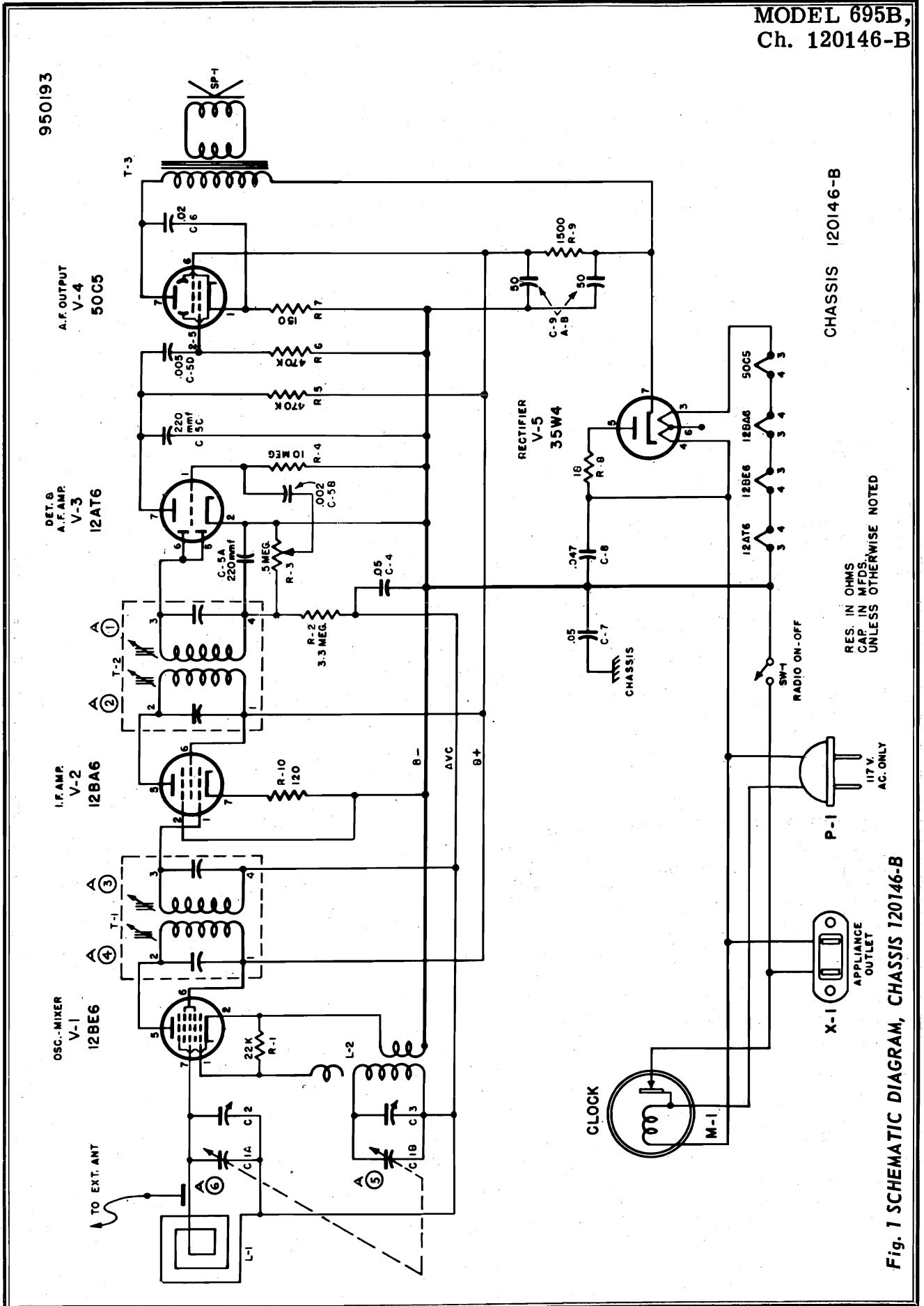

CHASSIS 120146-B

RES. IN OHMS
CAP. IN MFDS
UNLESS OTHERWISE NOTED

Fig. 1 SCHEMATIC DIAGRAM, CHASSIS 120146-B

MODEL 695B,
Ch. 120146-B

CHASSIS PARTS LIST (Chassis 120146-B)

SYM-BOL	PART NO.	DESCRIPTION	LIST PRICE	SYM-BOL	PART NO.	DESCRIPTION	LIST PRICE	
C-1A	900084	Variable Capacitor - r.f. Section	3.30	R-4	351452	10 megohm. Carbon	1/2 W±20% .14	
C-1B		Variable Capacitor - osc. Section		R-5	351132	470,000 ohm. Carbon	1/2 W±20% .14	
C-2	Pt. of C-1A	Trimmer - r.f. Section		R-6	351132	470,000 ohm. Carbon	1/2 W±20% .14	
C-3	Pt. of C-1B	Trimmer - osc. Section		R-7	340292	150 ohm. Carbon	1/2 W±10% .17	
C-4	923554	.05 mf. Paper 400V	.25	R-8	340072	18 ohm. Carbon	1/2 W±10% .14	
C-5A	470310	220 mmf. } Multiple Condenser	.75	R-9	380532	1,500 ohm. Carbon	1/2 W±20% .16	
C-5B		.002 mf. }		R-10	340272	120 ohm. Carbon	1/2 W±10% .14	
C-5C		220 mmf. }		SP-1	180081	Speaker - PM - 4 "	4.20	
C-5D		.005 mf. }						
C-6	923524	.02 mf. Paper 400V	.25	SW-1	510083	On - Off Switch - Radio	.25	
C-7	923554	.05 mf. Paper 400V	.25	T-1	720055	1st I.F. Transformer	1.85	
C-8	922200	.047 mf. Paper Molded 400V	.35	T-2	720033	2nd I.F. Transformer	2.15	
C-9A	925212	50 mf. Electrolytic 150V	2.10	T-3	734068	Output Transformer	1.95	
C-9B		50 mf. Electrolytic 150V						
L-1	700062	Loop Antenna & Back	1.75	V-1	800525	Vacuum Tube - 12BE6	1.80	
L-2	716064	Oscillator Coil	.95	V-2	800524	Vacuum Tube - 12BA6	1.80	
M-1	470672	Clock Movement		V-3	800523	Vacuum Tube - 12AT6	1.50	
P-1	583036	Line Cord & Plug		V-4	800032	Vacuum Tube - 50C5	2.00	
R-1	Pt. of L-2	22,000 ohm. Carbon 1/2 W±10%	.14	V-5	800526	Vacuum Tube - 35W4	1.25	
R-2	351332	3.3 megohm. Carbon 1/2 W±20%			X-1	500029	Appliance Outlet	.35
R-3	390186	500,000 ohm. Volume Control						

CABINET PARTS LIST FOR (Model 695B)

MODEL 695B	DESCRIPTION	LIST PRICE
140430	Cabinet - (Mottled Br.)	3.40
140432	Cabinet - (Ivory)	6.00
470672	Clock Movement	17.95
460242	Crystal - Clock	.25
450124	Knob - Radio - (Mottled Br.)	.20
450123	Knob - Radio - (Ivory)	.15
460245	Switch Knob - Clock	
280181	Time Set Knob - Clock	
542069	Speed Nut - Crystal	.01

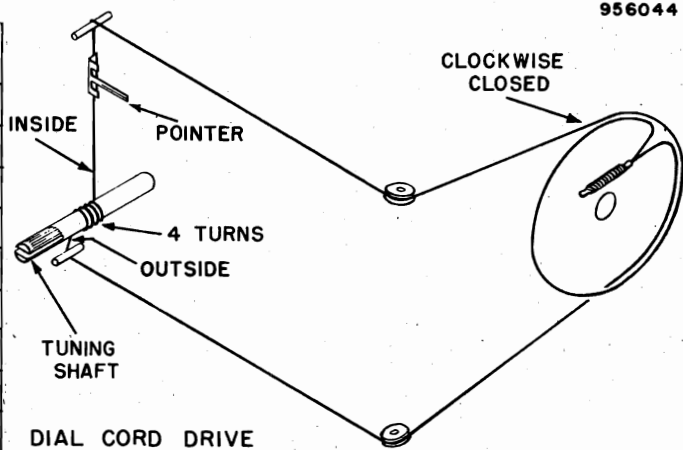

PRICES SUBJECT TO CHANGE WITHOUT NOTICE

Fig 2. DIAL CORD STRINGING MODEL 695B

MODEL 703B, Ch.
120097-B, 120108-B



MODEL 703B

DESCRIPTION

TYPE: Model 703B is a Single band superheterodyne receiver with a 3-speed automatic record changer.

FREQUENCY RANGE: 540-1620 kc.

TYPE OF TUBES:

Models 703B — chassis 120097B

1-12BE6, converter

1-12BA6, i-f amplifier

1-12AT6, detector, a.v.c., a-f amplifier

1-50B5, power output

1-35W4, rectifier

POWER SUPPLY: 115 volts, 60 cycles a.c. only

POWER CONSUMPTION—50 watts.

GENERAL NOTES

1. This model is equipped with an automatic record changer that plays 33-1/3, 45 and 78 rpm records, using a cartridge type needle.
2. If replacements are made or the wiring disturbed in the r-f section of Model 703B, the receiver should be carefully realigned.
3. Model 703B has a self-contained antenna and does not require an additional antenna. For permanent installations, however, if it is desired to improve reception of weak stations, an additional outdoor antenna may be connected to the colored lead at the rear of the cabinet.
4. The self-contained loop antenna has directional properties. It is important, therefore, once a station is tuned in, that the cabinet be rotated back and forth through a quarter-turn and left at that position where maximum volume is obtained.

CONDITIONS FOR VOLTAGE AND RESISTANCE READINGS

1. Voltages indicated are positive d.c., resistances are in ohms, unless otherwise indicated.
2. Measurements made with voltohmmyst or equivalent.
3. Line voltage maintained at 120 volts a.c. for voltage measurements.
4. Socket connections are shown as bottom views, with measurements from pin to common negative.
5. Volume control at maximum; radio-phonograph switch in radio position; no signal applied for Model 703B measurements.
6. Nominal tolerance on component values makes possible a variation of $\pm 15\%$ in voltage and resistance readings.
7. On the diagrams, upper values are voltage; lower values are resistance. NC denotes no connection, K is kilohms, MEG is megohms, INF. is infinity. Resistances marked * are measured to pin 7 of rectifier (B+).

ALIGNMENT INSTRUCTIONS — MODEL 703B

1. To position pointer, turn variable condenser fully closed and set pointer to reference mark at low-frequency end of dial backplate.
2. Use isolation transformer if available. If not, connect a .1 mfd. condenser in series with low side of signal generator and B—.
3. Volume control should be at maximum position; radio-phonograph switch in radio position. Output of signal generator should be no higher than necessary to obtain an output reading. Use an insulated screw driver for adjusting.

JULY 18, 1951

MODEL 703B, Ch.
120097-B, 120108-B

STEP	DUMMY ANTENNA	SIGNAL GENERATOR COUPLING	SIGNAL GENERATOR FREQUENCY	RADIO DIAL SETTING	OUTPUT METER	ADJUST	REMARKS
1	.1 mfd.	High side to grid (pin 7) of V1 (12BE6). Low side to chassis.	455 KC	Variable condenser fully open.	Across voice coil.	T2, T1	Adjust for maximum output. If isolation transformer is not used, reduce dummy ant. to .001 mfd. to reduce hum modulation.
2	200 mmf.	Form loop of several turns and radiate signal into receiver.	1620 KC	"	Across voice coil.	Trimmer C-4. (Osc.)	Adjust for maximum output.
3	200 mmf.	"	1400 KC	Tune for maximum output.	Across voice coil.	Trimmer C-3. (Ant.)	Adjust for maximum output.

950137

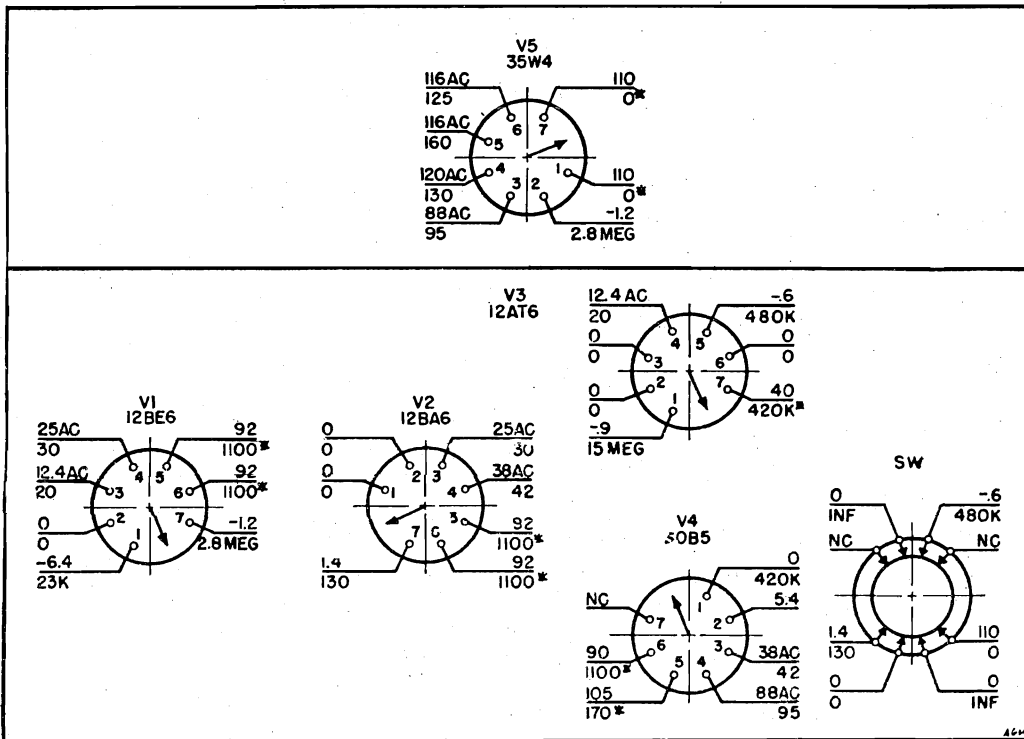
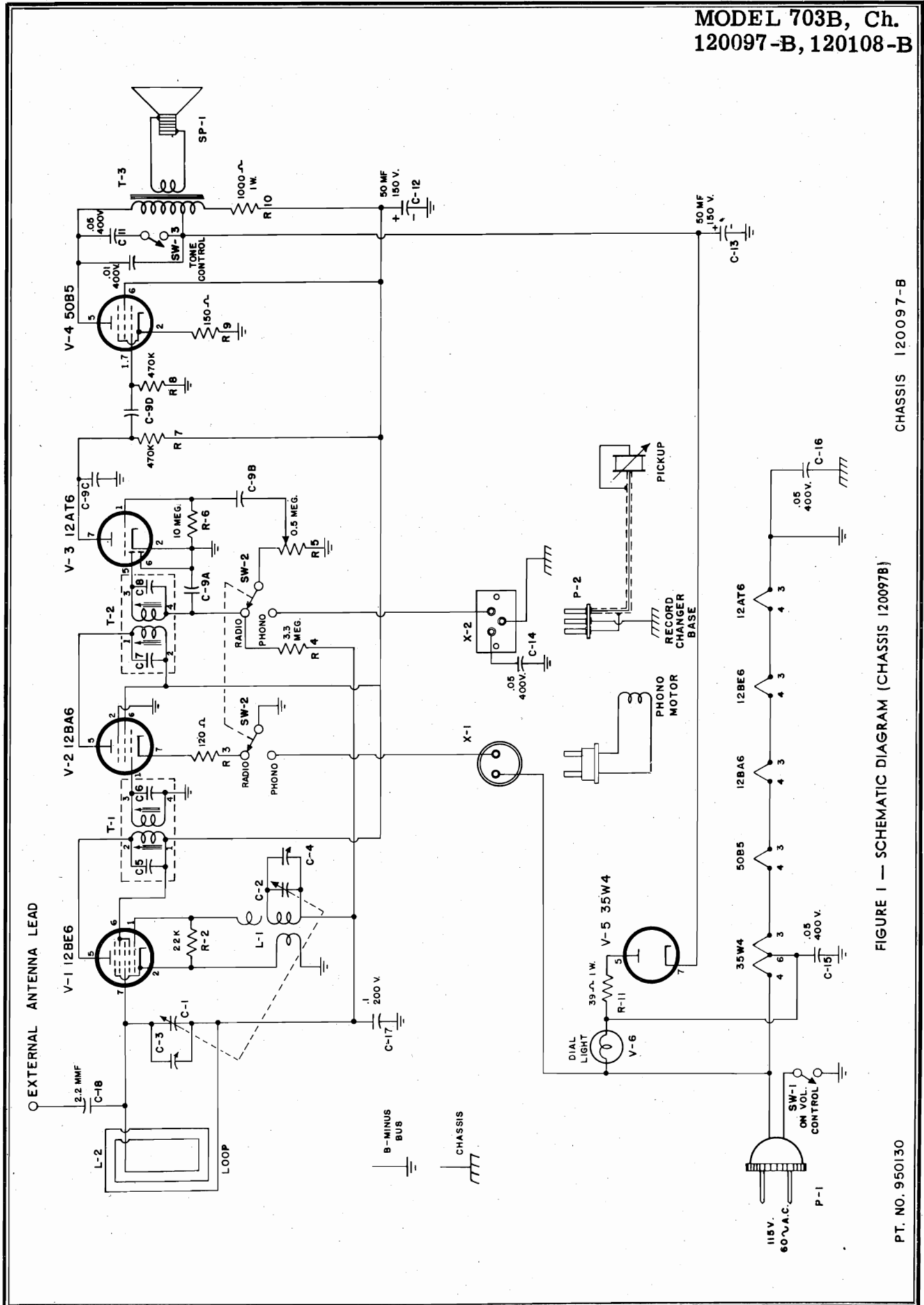

FIG. 2—VOLTAGE AND RESISTANCE CHECK CHART (CHASSIS 120097B)



CHASSIS 120097-B

FIGURE 1 — SCHEMATIC DIAGRAM (CHASSIS 120097B)

PT. NO. 950130

MODEL 703B, Ch.
120097-B, 120108-B

CHASSIS PARTS LIST (CHASSIS - 120097-B)

Symbol	Part No.	DESCRIPTION	Price List	Symbol	Part No.	DESCRIPTION	Price List
C-1 } C-2 } C-3 } C-4 } C-5 } C-6 } C-7 } C-8 }	900066	Variable Condenser-Tuning Variable Condenser-Oscillator Trimmer Trimmer	2.75	R-2 R-3 R-4	Pt. of L-1 340272 351332	22,000 Ohm Carbon ½W ±10% 120 Ohm Carbon ½W ±10% 3.3 Megohm Carbon ½W ±20%	.14
C-9A } C-9B } C-9C } C-9D }	470310	220 MMF) 2000 MMF) Multiple Condenser 220 MMF) 5000 MMF)	.75	R-5 R-6 R-7 R-8 R-9 R-10 R-11	510069-1 351452 351132 351132 340292 370492 370152	500,000 Ohm Volume Control 10 Megohm Carbon ½W ±20% 470,000 Ohm Carbon ½W ±20% 470,000 Ohm Carbon ½W ±20% 150 Ohm Carbon ½W ±10% 1,000 Ohm Carbon 1 W ±10% 39 Ohm Carbon 1 W ±10%	3.25 .14 .14 .14 .17 .16 .17
C-11 C-12 } C-13 } C-14 C-15 C-16 C-17 C-10	923554 925163 923554 923554 923554 923315 923713	.05 MF Paper 400V 50 MF Electrolytic 150V 50 MF Electrolytic 150V .05 MF Paper 400V .05 MF Paper 400V .05 MF Paper 400V .1 MF Paper 200V .001 MF Paper 600V	.25 1.45 .25 .25 .25 .25	SP-1 SW-1 SW-2 SW-3 T-1 T-2 T-3	180052 Pt. of R-5 Pt. of R-5 510068 720055 720055 734055	PM Speaker - 5" On-Off Switch Radio-Phono Switch Tone Control Switch 1st I.F. Transformer 2nd I.F. Transformer Output Transformer	4.90 .30 1.85 1.85 1.30
C-10 C-18 L-1 L-2 P-1 P-2	923514 Pt. of L-2 716061 700064 583028P 505015	.01 MF Paper 400V (Chassis 120108B only) Ceramic Oscillator Coil Loop Line Cord & Plug Pickup Plug	.25 .25 .95 1.29 .60 .10	V-1 V-2 V-3 V-4 V-5 V-6 X-1 X-2	800525 800524 800523 800527 800526 807000 585051 508003	Vacuum Tube - 12BE6 Vacuum Tube - 12BA6 Vacuum Tube - 12AT6 Vacuum Tube - 50B5 Vacuum Tube - 35W4 Dial Light Cable & Socket Assy. - Motor Pickup Socket	.49 .09 .45 .10

PRICES SUBJECT TO CHANGE WITHOUT NOTICE

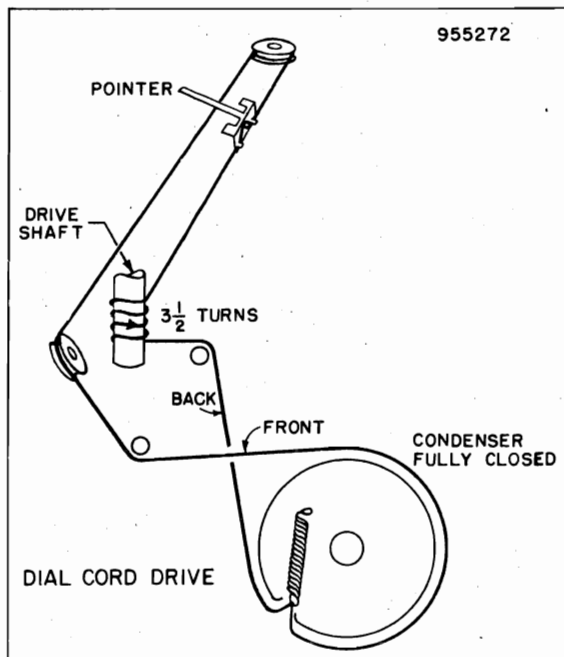
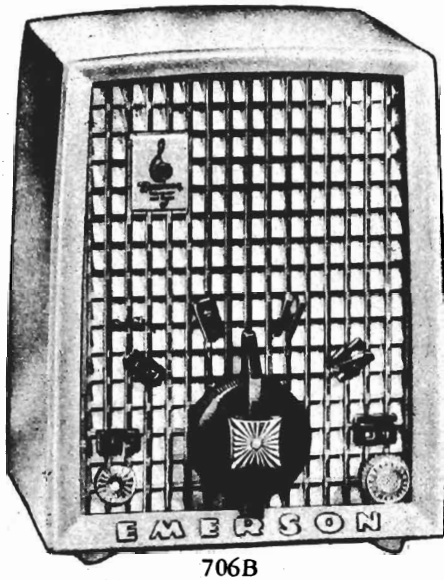

FIGURE 3. DIAL CORD STRINGING, MODEL 703B

CABINET PARTS LIST (MODEL 703B)

Part No.	DESCRIPTION	PRICE LIST
140438	Cabinet	90.00
470092	Lid Support	.50
819063	Record Changer (3-Speed)	65.00
960143	Cartridge for Record Changer	8.20
960147	Needle for Cartridge	1.00
450099S	Knob Assembly	.30
450064	Knob - Control	.25
450063	Knob - Radio - Phono	.25
587011	Spring Insert - Knobs	.01
520156	Glass Dial	.25
410863	Dial Holder	.01
700064	Loop Antenna	1.29

Prices subject to change without notice.



706B

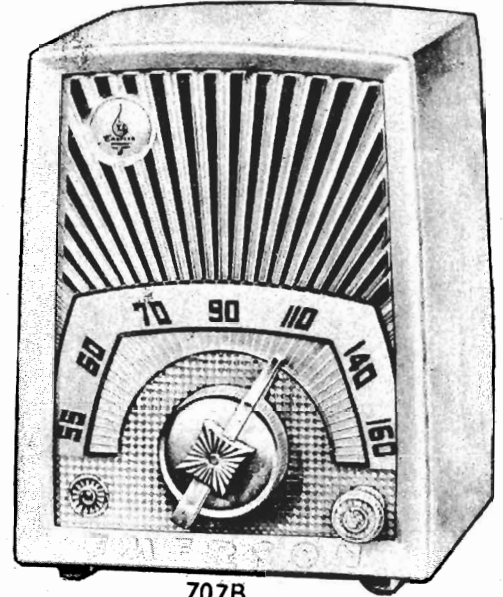

707B

DESCRIPTION

TYPE: Single-band (AM) superheterodyne.
FREQUENCY RANGE: Broadcast 540-1620 kc
TYPE OF TUBES:

- V-1--12BE6, converter
 - V-2--12BA6, i-f amplifier
 - V-3--12AT6, or 12AV6, detector, a.v.c. a-f amplifier
 - V-4--50C5, or 50B5 power output
 - V-5--35W4, rectifier
- POWER SUPPLY: A.C. or D.C.
VOLTAGE RATING: 105-125 volts.
POWER CONSUMPTION: 30 watts.
CURRENT DRAIN: 0.24 amp. at 117 volts a.c.

GENERAL NOTES

1. If replacements are made or the wiring disturbed in the r-f section of the circuit, the receiver should be carefully realigned.
2. In operating the receiver on d.c., it may be necessary to reverse the line plug for correct polarity.
3. Model 706B has a self-contained antenna and does not require additional antenna connections.
4. The self-contained bar type antenna operates at maximum efficiency when its position is pointing to the broadcasting source. It is important, therefore, once the station is tuned in, to rotate the cabinet back and forth through a quarter of a circle (90 degrees), leaving it at the position where the station is received with maximum volume.

ALIGNMENT INSTRUCTIONS

Use isolation transformer if available. If not, connect a .1 mfd. condenser in series with low side of signal generator and B - Volume control should be at maximum position. Output of signal generator should be no higher than necessary to obtain an output reading. Use an insulated screw driver for adjusting.

STEP	DUMMY ANTENNA	SIGNAL GENERATOR COUPLING	SIGNAL GENERATOR FREQUENCY	RADIO DIAL SETTING	OUTPUT METER	ADJUST	REMARKS
1	.1 mfd.	High side to grid (pin 7) of V1 (12BE6). Low side to B -	455 KC	Variable condenser fully open.	Across voice coil.	T2, T1 (A3, A4, A1, A2)	Adjust for maximum output. If isolation transformer is not used, reduce dummy ant. to .001 mfd. to reduce hum modulation.
2		Form loop of several turns and radiate signal into receiver	1620 KC	"	Across voice coil.	Trimmer C-4 (Osc.)	Adjust for maximum output.
3		"	1400 KC	Tune for maximum output.	Across voice coil.	Trimmer C-2 (Ant.)	Adjust for maximum output.

MODELS 706B, 707B,
Ch. 120156-B CONDITIONS FOR VOLTAGE AND RESISTANCE READINGS

1. Voltages indicated are positive d.c., resistances are in ohms, unless otherwise indicated.
2. Measurements made with voltohmmyst or equivalent.
3. Line voltage maintained at 117 volts a.c. for voltage measurements.
4. Socket connections are shown as bottom views, with measurements from pin to common negative.
5. Volume control at maximum; no signal applied for voltage measurements.
6. Nominal tolerance on component values makes possible a variation of $\pm 15\%$ in voltage and resistance readings.
7. On the diagram, upper values are voltage; lower values are resistance. NC denotes no connection, K is kilohms, MEG is megohms. Resistances marked * are measured to pin 7 of rectifier (B+).

VOLTAGE READINGS FOR CHASSIS 120156-B

SYMBOL	TUBE	PIN 1	PIN 2	PIN 3	PIN 4	PIN 5	PIN 6	PIN 7
V-1	12BE6	-7.6	0	12 AC	24 AC	95	95	-.5
V-2	12BA6	0	0	24 AC	36 AC	95	95	1.3
V-3	12AT6*	-1	0	0	12 AC	-.65	0	45
V-4	50C5	6.5	0	36 AC	85 AC	0	95	120
V-5	35W4	N.C.	N.C.	85 AC	117 AC	110 AC	112 AC	130

RESISTANT READINGS FOR CHASSIS 120156-B

SYMBOL	TUBE	PIN 1	PIN 2	PIN 3	PIN 4	PIN 5	PIN 6	PIN 7
V-1	12BE6	23K	.5	12	24	1500*	1500*	4 MEG
V-2	12BA6	18	0	24	36	1500*	1500*	120
V-3	12AT6*	6 MEG.	0	0	12	500K	0	470*
V-4	50C5*	150	470 K	36	90	470K	1500*	210*
V-5	35W4	N.C.	N.C.	90	120	135	115	0*

* In some models 12AV6 may be used as alternate for 12AT6.

* The 50C5 may be substituted with a 50B5 but only when the alternate circuit is used shown in schematic diagram.

VOLTAGE AND RESISTANCE READING INSTRUCTIONS

1. Line voltage maintained at 115 volts for voltage readings.
2. D.C. and A.C. voltages measured with V.T.V.M. All measurements measured with band switch on broadcast.
3. Measured values are from socket pin to B neutral. Volume control at maximum, no signal applied for voltage measurements.

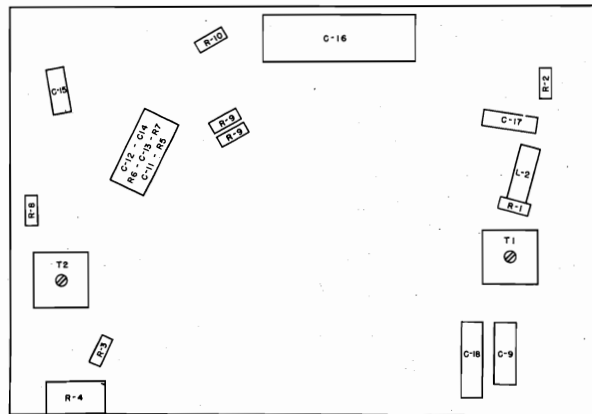

BOTTOM VIEW

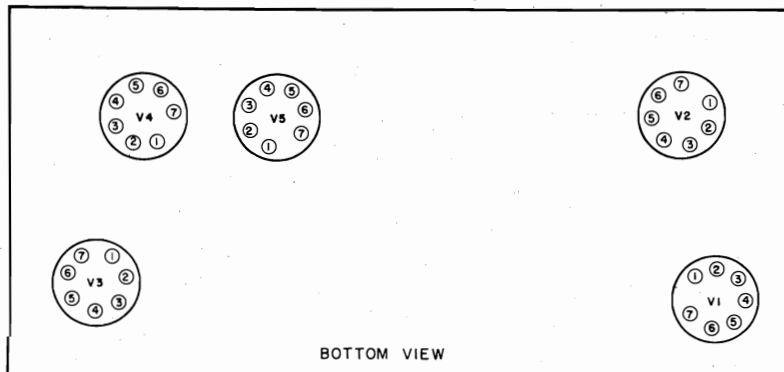

BOTTOM VIEW

MODELS 706B, 707B,
Ch. 120156-B

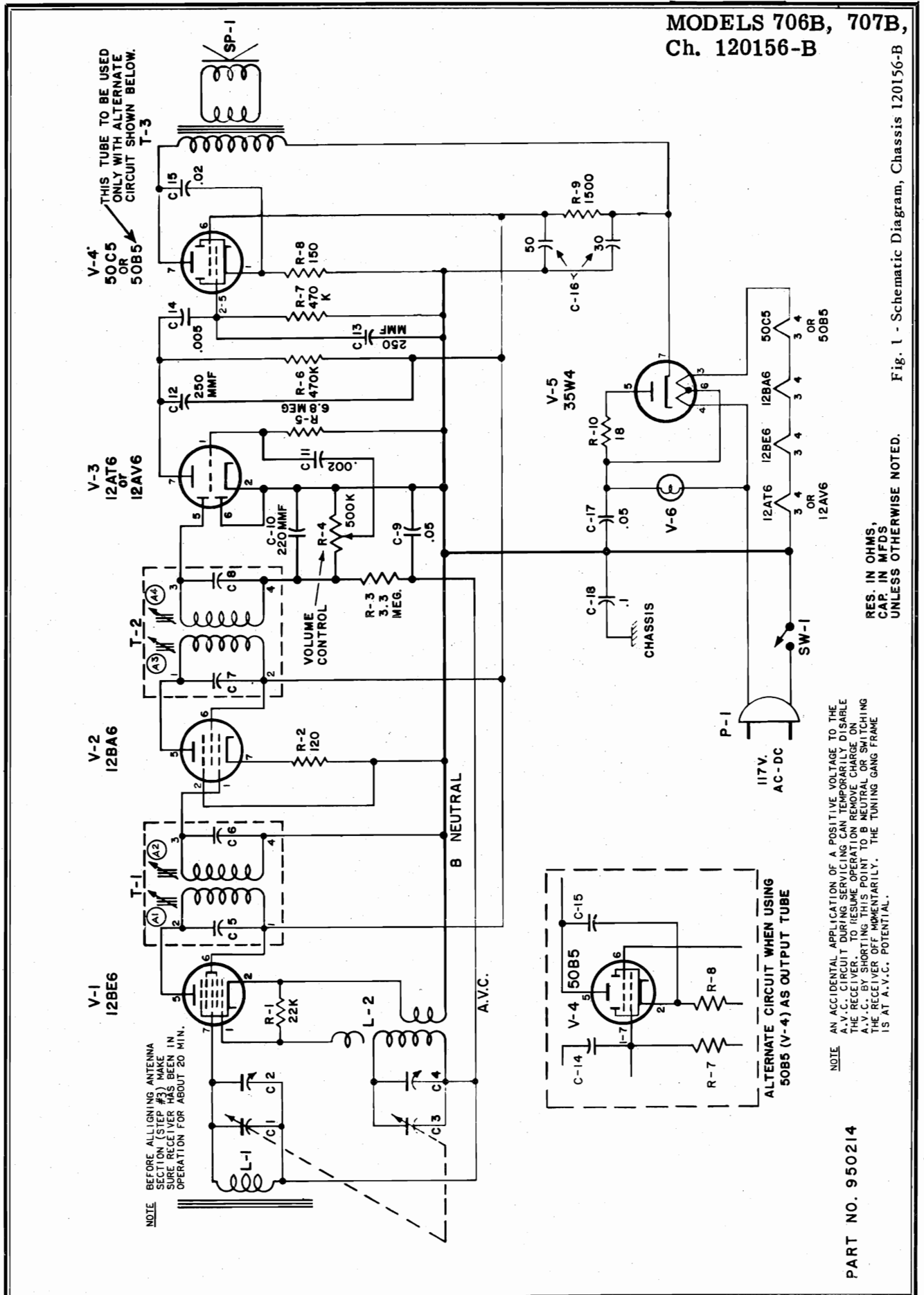

Fig. 1 - Schematic Diagram, Chassis 120156-B

RES. IN OHMS,
CAP. IN MFDS
UNLESS OTHERWISE NOTED.

NOTE: AN ACCIDENTAL APPLICATION OF A POSITIVE VOLTAGE TO THE A.V.C. CIRCUIT DURING SERVICING CAN TEMPORARILY DISABLE THE RECEIVER. TO RESUME OPERATION REMOVE CHARGE ON A.V.C. BY SHORTING THIS POINT TO B NEUTRAL OR SWITCHING THE RECEIVER OFF IMMEDIATELY. THE TUNING GANG FRAME IS AT A.V.C. POTENTIAL.

PART NO. 950214

MODELS 706B, 707B,
Ch. 120156-B

CHASSIS PARTS LIST (Chassis 120156-B)

SYM-BOL	PART NO.	DESCRIPTION	LIST PRICE	SYM-BOL	PART NO.	DESCRIPTION	LIST PRICE	
C-1	900086	Variable Capacitor - R.F. Sec.	3.25	R-1	Pt. of L-2	22,000 ohm Carbon		
C-2	PT. of C-1	Trimmer R.F. Sec.		R-2	340272	120 ohm Carbon $\frac{1}{2}W \pm 10\%$.14	
C-3	PT. of C-1	Variable Capacitor - Osc. Sec.		R-3	351332	3.3 megohm Carbon $\frac{1}{2}W \pm 20\%$.14	
C-4	PT. of C-1	Trimmer Osc. Sec.		R-4	390195	500,000 ohm Volume Control	1.30	
C-5	PT. of T-1			R-5	Part of 923024	6.8 megohm	R.C. Coupling Unit	
C-6	PT. of T-1			R-6		470,000 ohm		
C-7	PT. of T-2			R-7	923024	470,000 ohm	1.05	
C-8	PT. of T-2			R-8	340292	150 ohm Carbon $\frac{1}{2}W \pm 10\%$.17	
C-9	923554	.05 mfd Paper 400 V	.25	R-9	380532	1,500 ohm Carbon $1W \pm 20\%$.16	
C-10	Part of 923024	220 mmf	R.C. Coupling Unit	R-10	340072	18 ohm Carbon $\frac{1}{2}W \pm 10\%$.14	
C-11		.002 mf			SP-1	180084	Speaker - P.M. - 4" (with Output Trans.)	5.95
C-12		250 mmf			SW-1	Pt. of R-4	On-Off Switch	
C-13		250 mmf						
C-14		.005 mf						
C-15	923524	.02 mfd Paper 400 V	.25	T-1	720033	1st I.F. Transformer	2.15	
				T-2	720033	2nd I.F. Transformer	2.15	
C-16	925218	.30 mf } Electrolytic 150 V	1.85	T-3	Pt. of SP-1	Output Transformer		
		.50 mf }		V-1	800525	Vacuum Tube - 12BE6		
C-17	923554	.05 mfd Paper 400 V	.25	V-2	800524	Vacuum Tube - 12BA6		
C-18	923315	.1 mfd Paper 200 V	.25	V-3	800523	Vacuum Tube - 12AT6		
				V-3	or 800034	Vacuum Tube - 12AV6		
L-1	700066	Loop Antenna Assembly - Ferrite	1.85	V-4	800032	Vacuum Tube - 50C5		
L-2	716071	Oscillator Coil	.95	V-4	or 800527	Vacuum Tube - 50B5		
P-1	583037P	Line Cord & Plug		V-5	800526	Vacuum Tube - 35W4		
				V-6	807000	Pilot Light		

Prices subject to change without notice.

CABINET PARTS LIST 706B - 707B

PART NUMBERS		DESCRIPTION	LIST PRICE
MODEL 706B	MODEL 707B		
140450	140450	Cabinet Body - Walnut	1.70
140450A	140450A	Cabinet Body - Ivory	2.50
140450B	140450B	Cabinet Body - Grey	2.50
	140450C	Cabinet Body - Maroon	2.50
140450D	140450D	Cabinet Body - Pink	2.50
140450E	140450E	Cabinet Body - Gunmetal	2.50
140450F	140450F	Cabinet Body - Yellow	2.50
140451		Front Plate - Sprayed Gold	.60
	140452	Front Plate - Gold & Silver	1.60
	140452A	Front Plate - Gold and Ruby	1.90
460274		Knob Tuning	.50
	460314	Knob Tuning	.50
460311	460311	Knob - Volume	.10
542280	542280	Spring - Knob	.02
587329	587329	Fastener - Front to Body	.02
575839	575839	Cabinet Back	.10
575877		Baffle	.10
	575871	Baffle	.40
180084	180084	Speaker - P.M. 4" (with Output Transformer)	5.95
583037P	583037P	Line Cord & Plug	.80
807000	807000	Pilot Light	.80
700066	700066	Loop Antenna Assembly - Ferrite	1.85

Prices subject to change without notice.

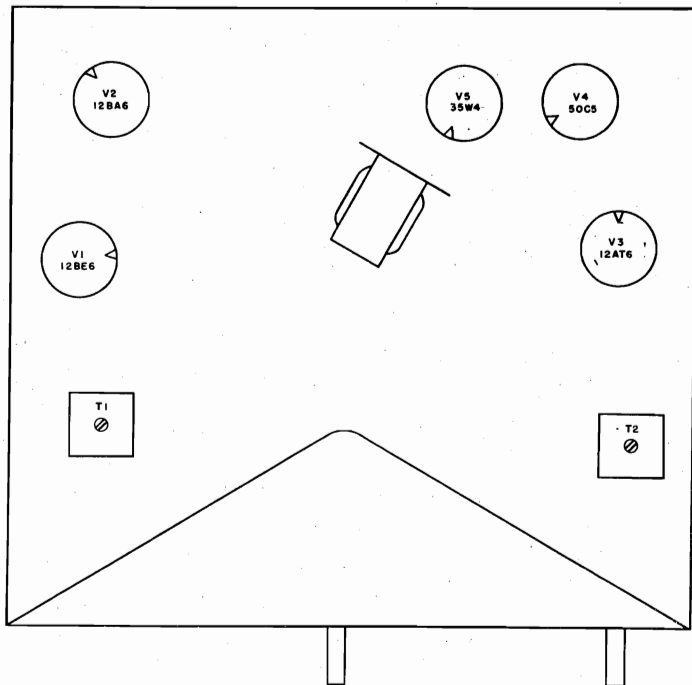

TOP VIEW

MODEL 718B, Ch. 120150-B

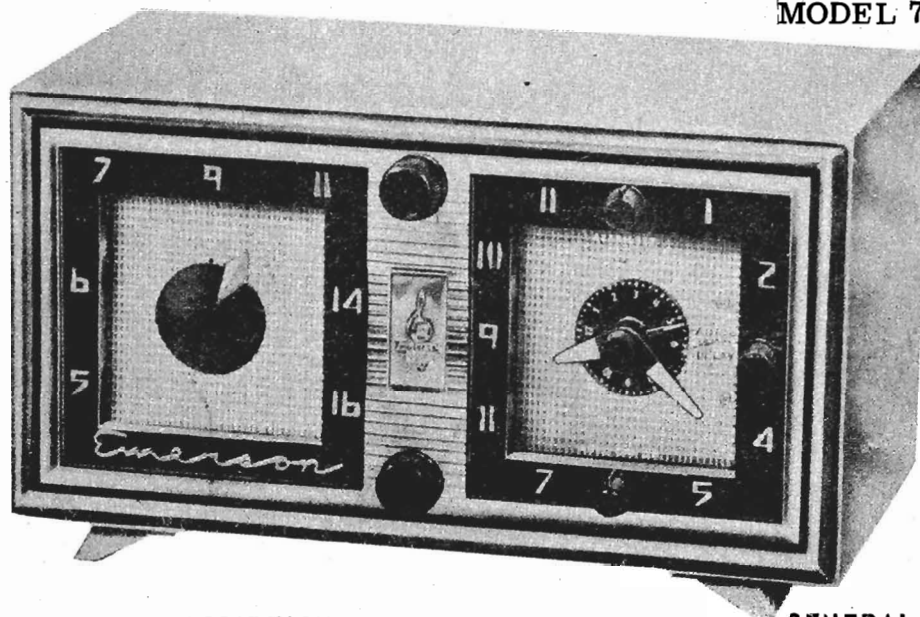

DESCRIPTION

TYPE: Single-band superheterodyne, with clock-timer and appliance outlet.

FREQUENCY RANGE: 540-1620 kc.

TYPE OF TUBES:

- V-1 - 12BE6, oscillator mixer
- V-2 - 12BA6, first i-f amplifier
- V-3 - 12AT6, detector, a-f amplifier
- V-4 - 50C5, A. F. output
- V-5 - 35W4, rectifier

POWER SUPPLY: A.C. 60 cycles only

VOLTAGE RATING: 115 volts.

POWER CONSUMPTION: 32 watts.

Pointer will be correctly set when tuning gang is fully open and notch or rim of pointer pulley is in line with mark on pointer pulley mounting bracket. (See Figure 2.) Use isolation transformer if available. If not, connect a 0.1 mfd. condenser in series with low side signal generator and chassis. Volume control should be at maximum position; output of signal generator should be no higher than necessary to obtain an output reading. Use an insulated alignment screwdriver for adjusting.

ALIGNMENT

GENERAL NOTES

1. If replacements are made or the wiring disturbed in the r-f section of the circuit, the receiver should be carefully realigned.
2. This model has a self-contained antenna and does not require additional antenna connections. For permanent home installations, however, if it is desired to improve reception of weak stations, an additional outdoor antenna may be used. For this purpose a lead has been brought out in the rear. Use no ground connection.
3. The self-contained bar loop antenna operates at maximum efficiency when it is pointed toward the broadcasting source. It is important, therefore, once the station is tuned in, to rotate the cabinet back and forth through a quarter of a circle (90 degrees), leaving it at the position where the station is received with maximum volume.
4. Appliance outlet and radio on/off switch located in back of chassis. For information on clock applications see instructions supplied with set.

	DUMMY ANTENNA	SIGNAL GENERATOR COUPLING	SIGNAL GENERATOR FREQUENCY	RADIO DIAL SETTING	METER OUTPUT	ADJUST	REMARKS
1	0.001 mfd.	High side to stator of rear section of tuning condenser. Low side to chassis.	455 kc	Variable condenser fully open.	Across voice coil.	A1, A2 A3, A4	Adjust for maximum output.
2	200 mmfd.	High side to external antenna lead. Low side to external ground lead.	1620 kc	Variable condenser fully open.	Across voice coil.	A5	Adjust for maximum output.
3	200 mmfd.	High side to external antenna lead. Low side to external ground lead.	1400 kc	Tune for maximum output.	Across voice coil.	A6	Adjust for maximum output.

MODEL 718B,
Ch. 120150-B

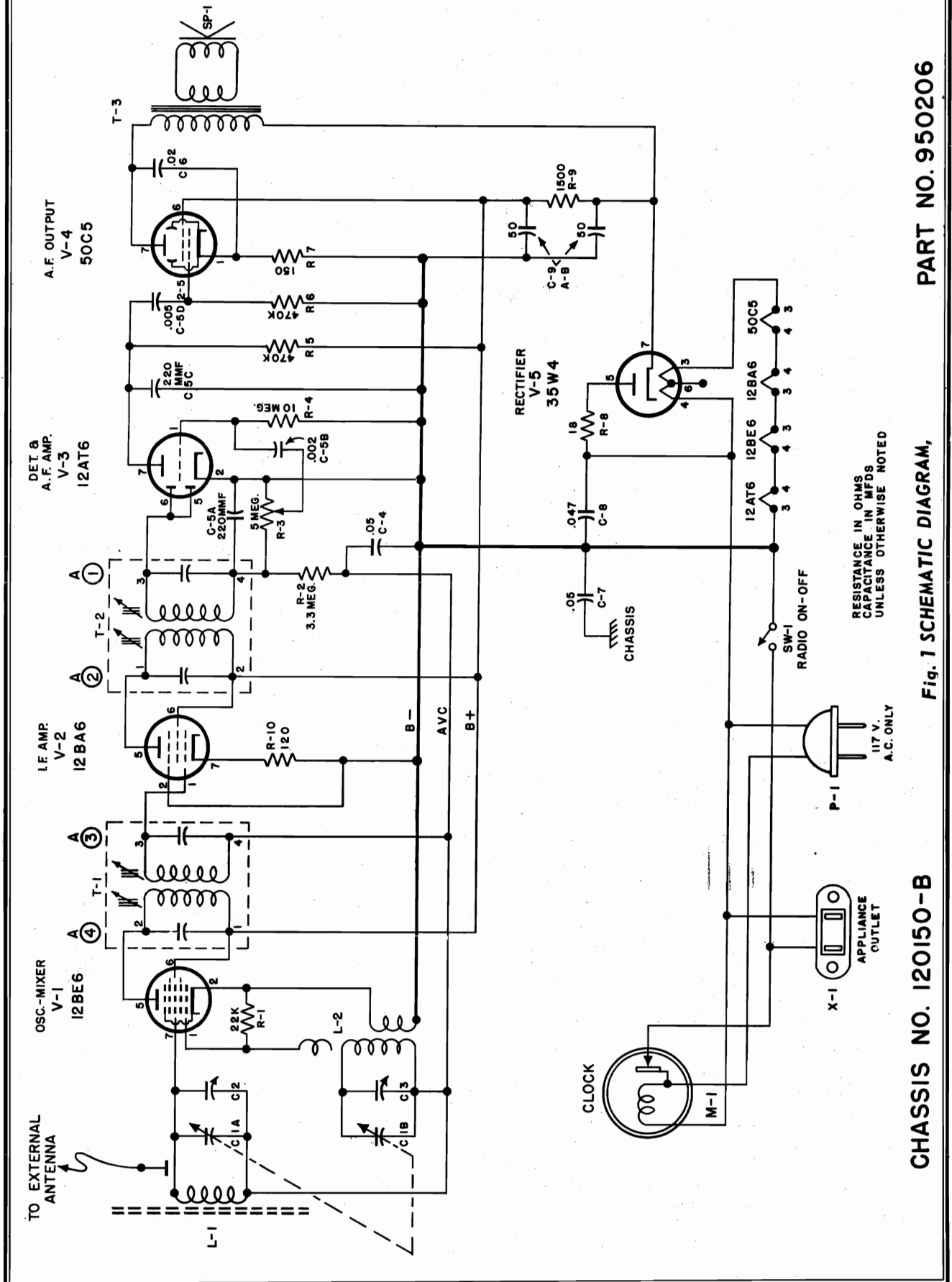

PART NO. 950206

Fig. 1 SCHEMATIC DIAGRAM,

CHASSIS NO. 120150-B

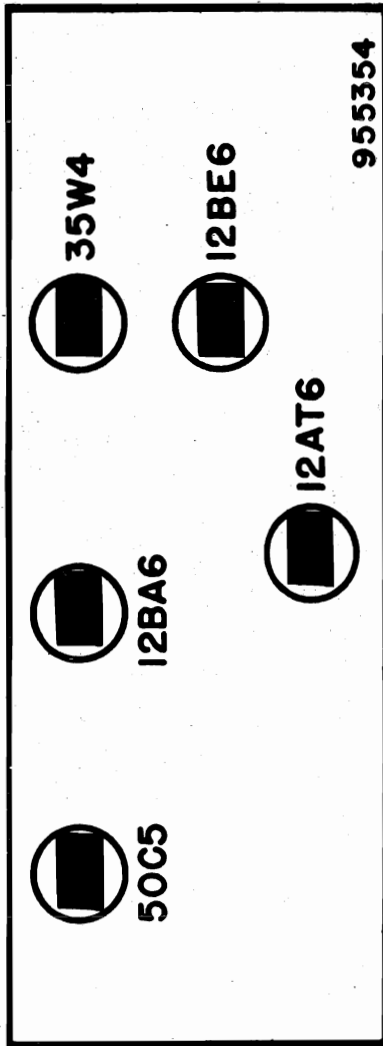
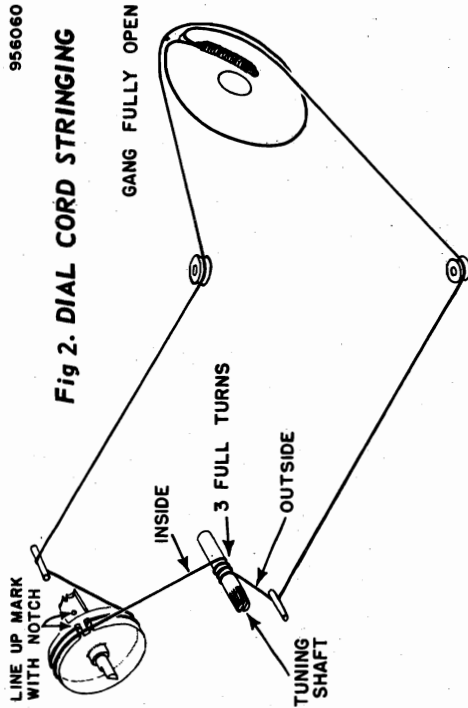

VOLTAGE READING FOR CHASSIS 120150-B

SYMBOL	TUBE	PIN 1	PIN 2	PIN 3	PIN 4	PIN 5	PIN 6	PIN 7
V-1	12BE6	-8.5 DC.	0	24 AC	12 AC	90 DC	90 DC	-6 DC.
V-2	12BA6	-6 DC.	0	24 AC	36 AC	90 DC	90 DC	1 DC
V-3	12AT6	-7DC.	0	0	12 AC	-8 DC.	-8 DC.	42 DC
V-4	50C5	5.6 DC.	0	80 AC	36 AC	0	90 DC	110 DC
V-5	35W4	0	0	80 AC	117 AC	115 AC.	110 AC	120 DC

RESISTANCE READING FOR CHASSIS 120150-B

SYMBOL	TUBE	PIN 1	PIN 2	PIN 3	PIN 4	PIN 5	PIN 6	PIN 7
V-1	12BE6	2.4 K	0.4	26	14	*1600	*1600	4 MEG.
V-2	12BA6	4 MEG.	0	26	38	*1600	*1600	130
V-3	12AT6	10 MEG.	0	0	14	.5 MEG.	.5 MEG.	*.5 MEG.
V-4	50C5	160	.5 MEG.	90	38	.5 MEG.	*1600	*200
V-5	35W4	N.C.	N.C.	90	125	150	120	*0

* with reference to Pin #7, 35W4.

VOLTAGE AND RESISTANCE READING INSTRUCTIONS

1. Voltage readings are in volts and resistance readings in ohms unless otherwise specified.
2. D-C voltage measurements are at 20,000 ohms per volt; a-c voltage measured at 1,000 ohms per volt.
3. Measured values are from socket pin to common negative, unless otherwise specified.
4. Line voltage maintained at 117 volts, 60 cycles for voltage readings.
5. Normal tolerance on component values makes possible a variation of $\pm 15\%$ in voltage and resistance readings.
6. Volume control at maximum, no signal applied for voltage measurements.

MODEL 718B,
Ch. 120150-B

CABINET PARTS LIST FOR (Model 718B)

MODEL 718B	DESCRIPTION	LIST PRICE
140472	Cabinet - Ivory	4.20
140472A	Cabinet - Black	4.20
140472B	Cabinet - Maroon	4.20
140472C	Cabinet - Blue	4.20
140472D	Cabinet - Grey	4.20
450154	Knob Radio - Black	█

460313	Cabinet - Front	3.25
592031	Grille Cloth Assembly	.20
460328	Switch Knob - Clock	
280195	Time Set Knob - Clock	.25
525059	Pointer	.03
541170	Spring - Pointer	.25
575895	Back	
470699	Clock Movement	

CHASSIS PARTS LIST (Chassis 120150-B)

SYM-BOL	PART NO.	DESCRIPTION	LIST PRICE	SYM-BOL	PART NO.	DESCRIPTION	LIST PRICE
C-1A	900084	Variable Capacitor - r.f. Section	3.30	R-4	351452	10 megohm. Carbon	.14
C-1B		Variable Capacitor - osc. Section		R-5	351132	470,000 ohm. Carbon	.14
C-2	Pt. of C-1A	Trimmer - r.f. Section		R-6	351132	470,000 ohm. Carbon	.14
C-3	Pt. of C-1B	Trimmer - osc. Section		R-7	340292	150 ohm. Carbon	.10
C-4	923554	.05 mf. Paper	.25	R-8	340072	18 ohm. Carbon	.14
C-5A	470310	220 mmf. Multiple Condenser	.75	R-9	380532	1,500 ohm. Carbon	.16
C-5B		.002 mf.		R-10	340272	120 ohm. Carbon	.14
C-5C		220 mmf.		SP-1	180087	Speaker - PM - 4"	3.00
C-5D		.005 mf.		SW-1	510083	On - Off Switch - Radio	.25
C-6		.02 mf. Paper		T-1	720055	1st I.F. Transformer	1.85
C-7	923554	.05 mf. Paper	.25	T-2	720033	2nd I.F. Transformer	1.80
C-8	922200	.047 mf. Paper Molded	.35	T-3	734068	Output Transformer	1.50
C-9A	925212	50 mf. Electrolytic	1.60	V-1	800525	Vacuum Tube - 12BE6	
C-9B		50 mf. Electrolytic	1.60	V-2	800524	Vacuum Tube - 12BA6	
L-1	700071	Bar Loop Antenna	2.15	V-3	800523	Vacuum Tube - 12AT6	
L-2	716064	Oscillator Coil	.95	V-4	800032	Vacuum Tube - 50C5	
M-1	470699	Clock Movement	█	V-5	800526	Vacuum Tube - 35W4	
P-1	583036	Line Cord & Plug	1.30	X-1	500034	Appliance Outlet	.25
R-1	Pt. of L-2	22,000 ohm. Carbon	.14	X-1	or 500029	Appliance Outlet	.35
R-2	351332	3.3 megohm. Carbon					
R-3	390206	500,000 ohm. Volume Control	.90				

PRICES SUBJECT TO CHANGE WITHOUT NOTICE

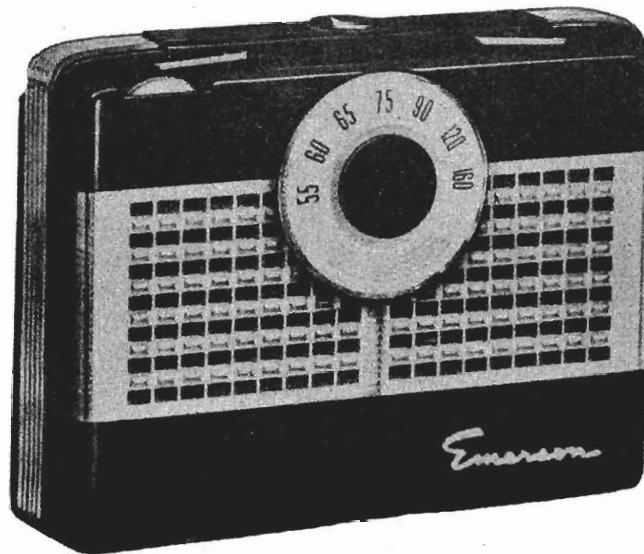
MODEL 704,
Ch. 120154-B

DESCRIPTION

MODEL 704

TYPE: Portable (battery operated) superheterodyne.

FREQUENCY RANGE: 540-1600 kc.

TYPE OF TUBES:

- 1-1R5, converter
- 1-1U4, i-f amplifier
- 1-1U5, detector, a.v.c., a-f amplifier
- 1-3V4, power output

POWER SUPPLY: "A" and "B" batteries.

VOLTAGE RATING:

- "A" Battery-1.5 volts
- "B" Battery-67.5 volts

CURRENT DRAIN:

- "A" Battery-0.20 amp.
- "B" Battery-0.0075 amp.

GENERAL NOTES

1. If replacements are made in the r-f section of the circuit, the receiver should be carefully realigned.
2. The receiver has a self-contained antenna and does not require additional antenna or ground connection.
3. The self-contained bar type antenna has directional properties. It is important, therefore, once the station is tuned in, to rotate the cabinet back and forth through a quarter of a circle (90 degrees), leaving it at the position where the station is received with maximum volume.
4. Remove batteries as soon as they are exhausted.
5. This receiver uses one Emerson 67.5 volt "B" battery No. EM 216 dimensions $5\frac{1}{4}$ " x 1" x $1\frac{7}{8}$ " and two Emerson 1.5 volt "A" batteries No. EM 236 dimensions are $1\frac{3}{8}$ " dia. and 4" length.

ALIGNMENT INSTRUCTIONS

Volume control should be at maximum; output of signal generator should be no higher than necessary to obtain an output reading.

	DUMMY ANTENNA	SIGNAL GENERATOR COUPLING	SIGNAL GENERATOR FREQUENCY	RADIO DIAL SETTING	OUTPUT METER	ADJUST	REMARKS
1	.1 mfd.	High side to pin 6 (grid) of 1R5. Low side to chassis.	455 KC.	Tuning condenser fully open.	Across voice coil.	T2 and T1	Adjust for maximum output.
2		Loop Ant connected to signal gen. and placed near bar loop ant.	600 KC.	Tuning condenser fully closed.	Across voice coil.	Osc. slug in L-2	Adjust for maximum output.
3		Loop	1620 KC.	Tuning condenser fully open.	Across voice coil.	C4 (osc. trimmer)	Fashion loop of several turns of wire and radiate signal into loop of receiver. Adjust for maximum output.
4		Loop	1400 KC.	Tune for maximum output.	Across voice coil.	C3 (Ant. trimmer)	Adjust for maximum output.

MODEL 704,
Ch. 120154-B

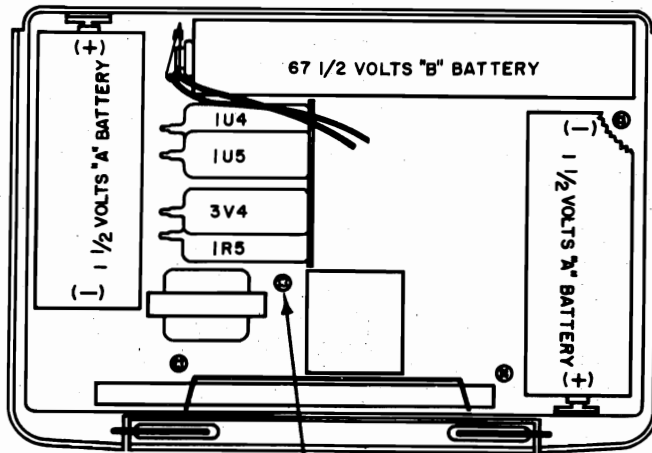

CHASSIS MOUNTING SCREWS (4)
BATTERY & TUBE LOCATIONS 955375

CONDITIONS FOR VOLTAGE AND RESISTANCE READINGS

1. Voltages indicated are positive d.c., resistances in ohms, unless otherwise noted.
2. Measurements made with voltohmyst or equivalent.
3. All measurements taken between points and chassis, unless otherwise indicated.
4. Volume control at maximum, no signal applied, for voltage measurements.
5. Nominal tolerance in component values makes possible a variation of $\pm 15\%$ in readings.
6. K is Kilohms, MEG in mehoohms. Resistance marked * are measured to B + (Pin #3, V-4).

RESISTANCE READINGS FOR CHASSIS 120154-B

SYMBOL	TUBE	PIN 1	PIN 2	PIN 3	PIN 4	PIN 5	PIN 6	PIN 7
V-1	1R5	0	17*	15K*	110K	0	4M	3.3
V-2	1U4	0	17*	0*	0*	0	5M	3.3
V-3	1U5	0	1M*	4.7M*	1M	1M	10M	3.3
V-4	3V4	3.3	350*	0*	470	0	3M	3.3

VOLTAGE READINGS FOR CHASSIS 120154-B

SYMBOL	TUBE	PIN 1	PIN 2	PIN 3	PIN 4	PIN 5	PIN 6	PIN 7
V-1	1R5	0	58	38	- 9	0	- .4	1.3
V-2	1U4	0	58	58	58	0	0	1.3
V-3	1U5	0	19	16	- .7	- .8	- .1	1.3
V-4	3V4	1.3	56	58	- 3.8	0	- 3.8	1.3

All measurements taken between points and chassis unless otherwise indicated.

* Measured to B + (Pin #3, V-4).

• For best results replacements should be made with genuine Emerson parts and genuine Emerson tubes.

PART NO. 950213

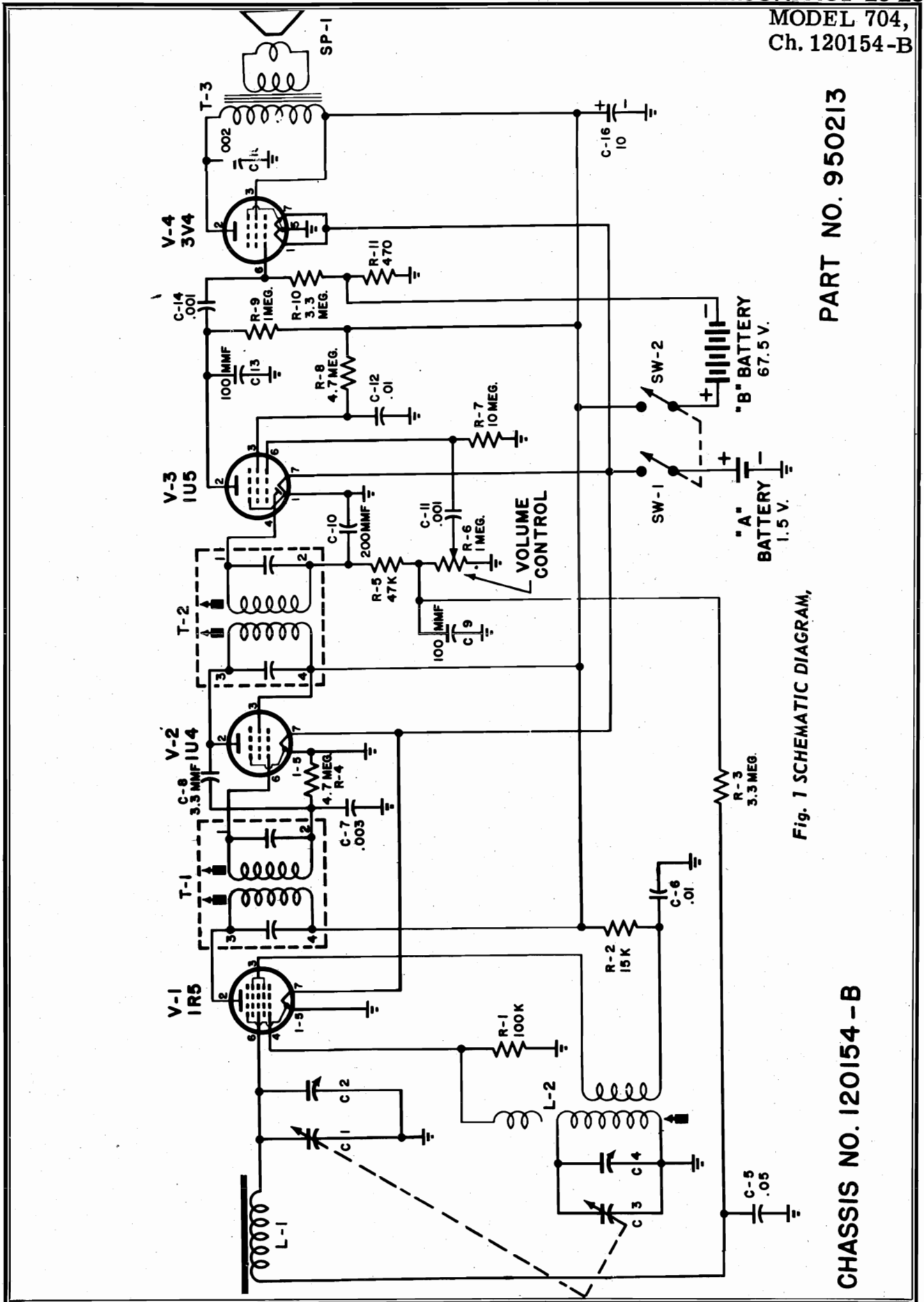

Fig. 1 SCHEMATIC DIAGRAM,

CHASSIS NO. 120154-B

MODEL 704,
Ch. 120154-B

CHASSIS PARTS LIST (Chassis 120154-B)

Sym- bol	Part No.	Description	List Price	Sym- bol	Part No.	Description	List Price
C-1	900085	Variable Capacitor - R.F. Section	3.05	R-4	351372	4.7 megohm Carbon	.14
C-2	Pt. of C-1	Trimmer - R. F. Section		R-5	340892	47,000 ohm Carbon	.17
C-3	Pt. of C-1	Variable Capacitor - Oscillator Section		R-6	390194	1 megohm Volume Control	1.65
C-4	Pt. of C-1	Trimmer - Oscillator Section		R-7	351452	10 megohm Carbon	.14
C-5	920507	.05 mf Paper	.30	R-8	351372	4.7 megohm Carbon	.14
C-6	920509	.01 mf Paper	.25	R-9	341212	1 megohm Carbon	.14
C-7	920140	.003 mf Paper	.25	R-10	351332	3.3 megohm Carbon	.14
C-8	915032	3.3 mmf Ceramic	.10	R-11	340412	470 ohm Carbon	.14
C-9	928013	100 mmf Ceramic	.25	SP-1	180085	Speaker - PM - 3 1/2"	4.90
C-10		200 mmf		SW-1	Part of	On - Off Switch	
C-11	Part of	.001 mf		SW-2	Pt. No.	On - Off Switch	
C-12	Part No.	.01 mf	.95	T-1	720152	1st I.F. Transformer	.95
C-13	928034	100 mf		T-2	720152	2nd I.F. Transformer	2.05
C-14		.001 mf		T-3	734076	Output Transformer	1.75
C-15	920550	.002 mf Paper	.20	V-1	810110	Vacuum Tube - 1R5	
C-16	925217	10 mf Electrolytic	1.20	V-2	800017	Vacuum Tube - 1U4	
L-1	700069	Bar Antenna	2.15	V-3	800019	Vacuum Tube - 1U5	
L-2	716072	Oscillator Coil	1.15	V-4	800018	Vacuum Tube - 3V4	
R-1	350972	100,000 ohm Carbon	.17				
R-2	340772	15,000 ohm Carbon	.14				
R-3	351332	3.3 megohm Carbon	.14				

Prices subject to change without notice.

CABINET PARTS LIST (Model 704)

PART NO.	DESCRIPTION	LIST PRICE	PART NO.	DESCRIPTION	LIST PRICE
Model 704	Cabinet	5.80	460291	Dial Knob	.70
140461	Cabinet Front - with Handle	3.50	450139	Knob - Volume	.20
140462	Cabinet Back	1.50	411241	Metal Ring - Knob	.03
460286	Handle Plastic	.80	542280	Compression Spring - Knob	.02
411239	Handle Ring	.05	460286	Emerson Script	.50

Prices subject to change without notice.

MODELS 708B, Ch. 120165-B;
713B, Ch. 120156-B

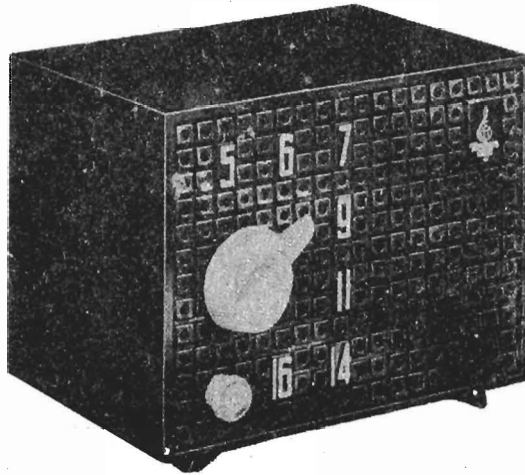

MODEL
708B
CHASSIS - 120165-B

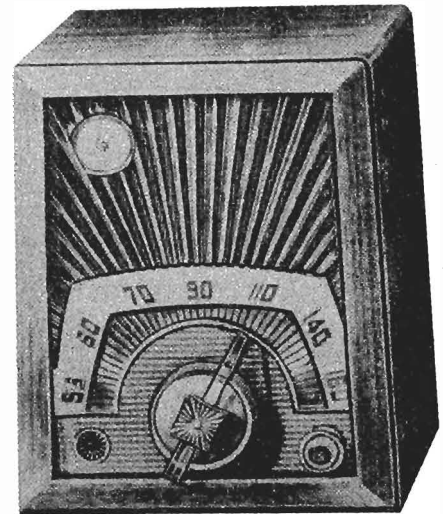

MODEL
713B
CHASSIS - 120156-B

DESCRIPTION

TYPE: Single-band (AM) superheterodyne.

FREQUENCY RANGE: Broadcast 540-1620 kc

TYPE OF TUBES:

V-1--12BE6, converter

V-2--12BA6, i-f amplifier

V-3--12AT6, detector, a.v.c. a-f amplifier

V-4--50C5, power output

V-5--35W4, rectifier

POWER SUPPLY: A.C. or D.C.

VOLTAGE RATING: 105-125 volts.

POWER CONSUMPTION: 30 watts.

CURRENT DRAIN: 0.24 amp. at 117 volts a.c.

GENERAL NOTES

1. If replacements are made or the wiring disturbed in the r-f section of the circuit, the receiver should be carefully realigned.
2. In operating the receiver on d.c., it may be necessary to reverse the line plug for correct polarity.
3. Models 708B and 713B have a self-contained antenna and do not require additional antenna connections.
4. The self-contained bar type antenna operates at maximum efficiency when its position is pointing to the broadcasting source. It is important, therefore, once the station is tuned in, to rotate the cabinet back and forth through a quarter of a circle (90 degrees), leaving it at the position where the station is received with maximum volume.

MODELS 708B, Ch. 120165-B;
713B, Ch. 120156-B

CONDITIONS FOR VOLTAGE AND RESISTANCE READINGS

1. Voltages indicated are positive d.c., resistances are in ohms, unless otherwise indicated.
2. Measurements made with voltohmmyst or equivalent.
3. Line voltage maintained at 117 volts a.c. for voltage measurements.
4. Socket connections are shown as bottom views, with measurements from pin to common negative.
5. Volume control at maximum; no signal applied for voltage measurements.
6. Nominal tolerance on component values makes possible a variation of $\pm 15\%$ in voltage and resistance readings.
7. NC denotes no connection, K is kilohms, MEG is megohms. Resistances marked * are measured to pin 7 of rectifier (B +).

ALIGNMENT INSTRUCTIONS

1. Use isolation transformer if available. If not, connect a .1 mfd. condenser in series with low side of signal generator and B -
2. Volume control should be at maximum position. Output of signal generator should be no higher than necessary to obtain an output reading. Use an insulated screw driver for adjusting.

STEP	DUMMY ANTENNA	SIGNAL GENERATOR COUPLING	SIGNAL GENERATOR FREQUENCY	RADIO DIAL SETTING	OUTPUT METER	ADJUST	REMARKS
1	.1 mfd.	High side to grid (pin 7) of V1 (12BE6). Low side to B -	455 KC	Variable condenser fully open.	Across voice coil.	T2, T1 (A3, A4, A1, A2)	Adjust for maximum output. If isolation transformer is not used, reduce dummy ant. to .001 mfd. to reduce hum modulation.
2		Form loop of several turns and radiate signal into receiver	1620 KC	"	Across voice coil.	Trimmer C-4 (Osc.)	Adjust for maximum output.
3		"	1400 KC	Tune for maximum output.	Across voice coil.	Trimmer C-2 (Ant.)	Adjust for maximum output.

VOLTAGE READINGS FOR CHASSIS 120156-B and 120165-B

SYMBOL	TUBE	PIN 1	PIN 2	PIN 3	PIN 4	PIN 5	PIN 6	PIN 7
V-1	12BE6	-7.6	0	12 AC	24 AC	95	95	-.5
V-2	12BA6	0	0	24 AC	36 AC	95	95	1.3
V-3	12AT6 ⊕	-1	0	0	12 AC	-.65	0	45
V-4	50C5	6.5	0	36 AC	85 AC	0	95	120
V-5	35W4	N.C.	N.C.	85 AC	117 AC	110 AC	112 AC	130

RESISTANT READINGS FOR CHASSIS 120156-B and 120165-B

SYMBOL	TUBE	PIN 1	PIN 2	PIN 3	PIN 4	PIN 5	PIN 6	PIN 7
V-1	12BE6	23K	.5	12	24	1500*	1500*	4 MEG
V-2	12BA6	18	0	24	36	1500*	1500*	120
V-3	12AT6 ⊕	6 MEG	0	0	12	500K	0	470*
V-4	50C5	150	470 K	36	90	470K	1500*	210*
V-5	35W4	N.C.	N.C.	90	120	135	115	0*

⊕ In some models 12AV6 may be used as alternate for 12AT6.

* Resistances measured to pin 7 of rectifier (B +).

VOLTAGE AND RESISTANCE READING INSTRUCTIONS

1. Line voltage maintained at 115 volts for voltage readings.
2. D.C. and A.C. voltages measured with V.T.V.M.
3. Measured values are from socket pin to B neutral.
4. Volume control at maximum, no signal applied for voltage measurements.

MODELS 708B, Ch.
120165-B; 713B, Ch.
120156-B

CHASSIS NO. 120165-B
120156-B

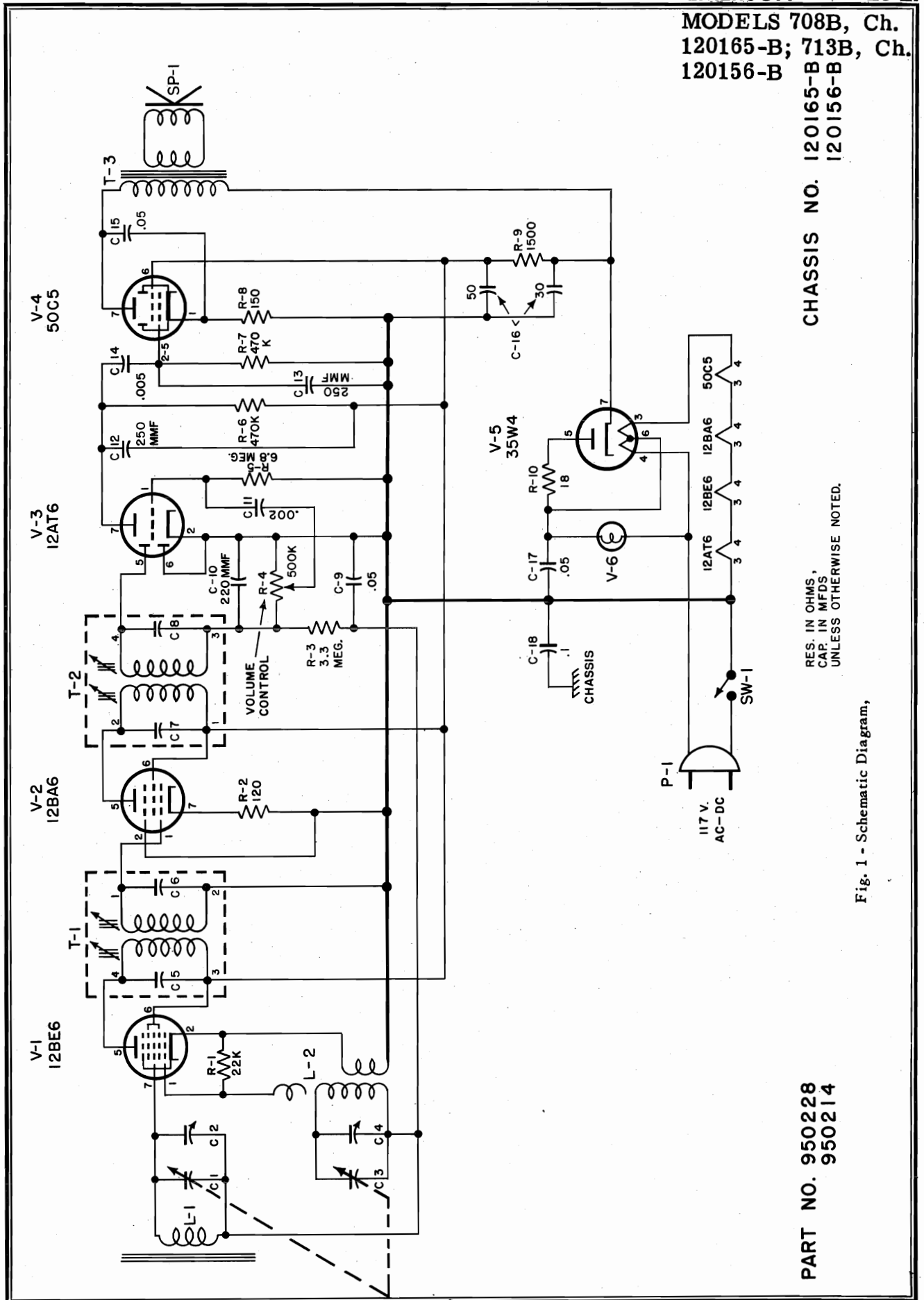

RES. IN OHMS,
CAP. IN MFDS
UNLESS OTHERWISE NOTED.

Fig. 1 - Schematic Diagram,

PART NO. 950228
950214

MODELS 708B, Ch. 120165-B;
713B, Ch. 120156-B

CHASSIS PARTS LIST (Chassis 120156-B and 120165-B)

SYM-BOL	PART NO.	DESCRIPTION	LIST PRICE	SYM-BOL	PART NO.	DESCRIPTION	LIST PRICE	
C-1	900086	Variable Capacitor - R.F. Sec.	3.25	P-1	583037P	Line Cord and Plug	.55	
C-2	PT. of C-1	Trimmer RF Sec.		R-1	Pt.of L-2	22000 ohm Carbon		
C-3	PT. of C-1	Variable Capacitor - Osc. Sec.		R-2	340272	120 ohm Carbon 1/2W ±10%	.14	
C-4	PT. of C-1	Trimmer Osc. Sec.		R-3	351332	3.3 megohm Carbon 1/2W ±20%	.14	
C-5	PT. of T-1			R-4	390205	500,000 ohm Volume Control	1.30	
C-6	PT. of T-1			R-5	Part	6.8 megohm		
C-7	PT. of T-2			R-6	of	470,000 ohm	R.C. Coupling Unit	
C-8	PT. of T-2			R-7	923024	470,000 ohm		
C-9	923554	.05 MFD Paper 400V.	.25	R-8	340292	150 ohm Carbon 1/2W ±10%	.10	
C-10	923024	220 MMF	1.05	R-9	380532	1,500 ohm Carbon 1W ±20%	.16	
C-11		.002 MF		R-10	340072	18 ohm Carbon 1/2W ±10%	.14	
C-12		250 MMF		R.C. Coupling Unit	SP-1	180084 or	Speaker-P.M.-4" (with Output Trans.) For Chassis 120156 only.	4.95
C-13		250 MMF			SP-1	180088		
C-14	.005 MF		SP-1	180086 or	Speaker-P.M.-4" (with Output Trans.) For Chassis 120165-B only.	6.55		
C-15	923554	.05 MFD Paper 400V.	SP-1	180090				
C-16	925218	30 MF Electrolytic 150V. 50 MF	1.40	SW-1	Pt.of R-4	On-Off Switch		
C-17	923554	.05 MFD Paper 400V.	.25	T-1	720033	1st I.F. Transformer	1.80	
C-18	923515	.1 MFD Paper 400V.	.30	T-2	720033	2nd I.F. Transformer	1.80	
L-1	700066	Loop Antenna Assembly - Ferrite For Chassis 120156-B Only	1.85	T-3	Pt.of SP-1	Output Transformer		
L-1	700072	Loop Antenna Assembly - Ferrite For Chassis 120165-B Only	1.85	V-1	800525	Vacuum Tube - 12BE6		
L-2	716071	Oscillator Coil	.95	V-2	800524	Vacuum Tube - 12BA6		
				V-3	800523	Vacuum Tube - 12AT6		
				V-4	800032	Vacuum Tube - 50C5		
				V-5	800526	Vacuum Tube - 35W4		
				V-6	807000	Pilot Light		

Prices subject to change without notice.

CABINET PARTS LIST - MODELS 708B, 713B

MODELS		DESCRIPTION	LIST PRICE
708B	713B		
140473		Cabinet	2.00
	140477	Cabinet - Wood	8.00
	140452B	Front Plate - Gold & Dull Silver	2.40
575897		Baffle	.30
	575871	Baffle	.40
460326		Knob - Tuning	.45
	460312	Knob - Tuning	.20
460311	460311	Knob - Volume	.10
542280	542280	Spring - Knob	.02
575898		Back	.10
	575839	Back	.10
635001		Jewel Amber	.12

Prices subject to change without notice.

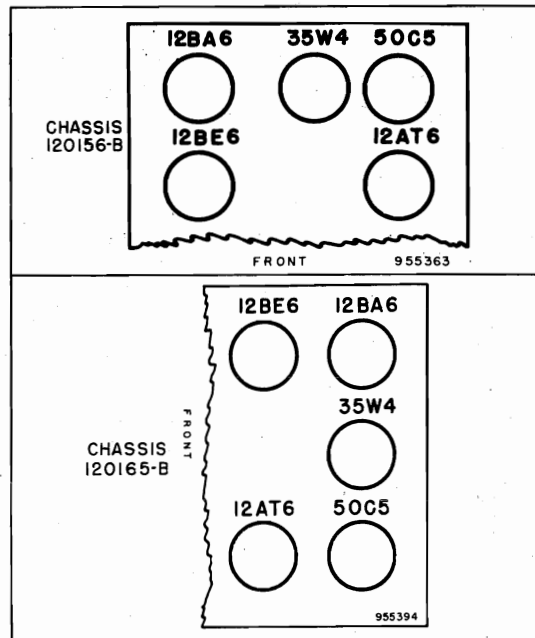
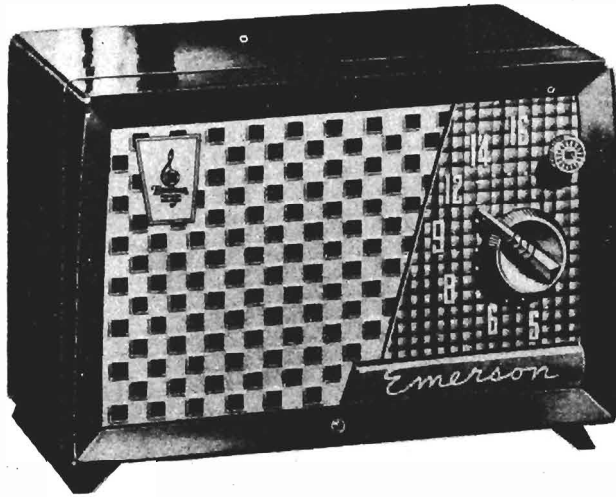
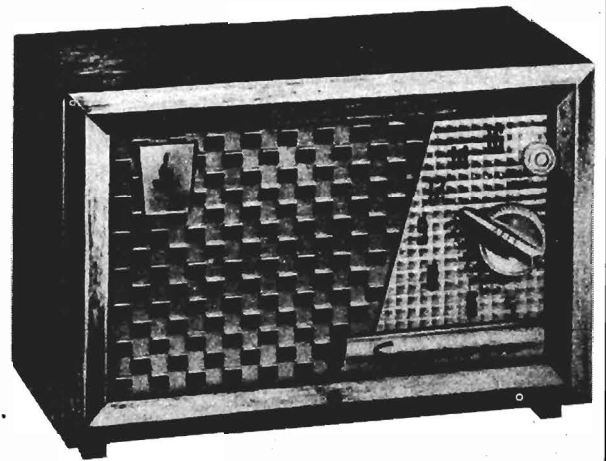

Fig. 2 Tube Location Diagram of Chassis 120156-B, 120165-B



MODEL 729B



MODEL 779B

DESCRIPTION

TYPE: Single-band (AM) superheterodyne.

FREQUENCY RANGE: Broadcast 540-1620 kc

TYPE OF TUBES:

V-1--12BE6, converter

V-2--12BA6, i-f amplifier

V-3--12AT6, detector, a.v.c. a-f amplifier

V-4--50C5, power output

V-5--35W4, rectifier

POWER SUPPLY: A.C. or D.C.

VOLTAGE RATING: 105-125 volts.

POWER CONSUMPTION: 30 watts.

CURRENT DRAIN: 0.24 amp. at 117 volts a.c.

GENERAL NOTES

1. If replacements are made or the wiring disturbed in the r-f section of the circuit, the receiver should be carefully realigned.
2. In operating the receiver on d.c., it may be necessary to reverse the line plug for correct polarity.
3. This model has a self-contained antenna and does not require additional antenna connections. For permanent home installations, however, if it is desired to improve reception of weak stations, an additional outdoor antenna may be used. For this purpose a lead has been brought out in the rear. Use no ground connection.
4. The self-contained loop antenna operates at maximum efficiency when its position is pointing to the broadcasting source. It is important, therefore, once the station is tuned in, to rotate the cabinet back and forth through a quarter of a circle (90 degrees), leaving it at the position where the station is received with maximum volume.

MODELS 729B, 779B,
Ch. 120170-B

CONDITIONS FOR VOLTAGE AND RESISTANCE READINGS

1. Voltages indicated are positive d.c., resistances are in ohms, unless otherwise indicated.
2. Measurements made with voltohmmyst or equivalent.
3. Line voltage maintained at 117 volts a.c. for voltage measurements.
4. Measurements taken from pin to B neutral.
5. Volume control at maximum; no signal applied for voltage measurements.
6. Nominal tolerance on component values makes possible a variation of $\pm 15\%$ in voltage and resistance readings.
7. NC denotes no connection, K is kilohms, MEG is megohms. Resistances marked * are measured to pin 7 of rectifier 35W4 (B+).

ALIGNMENT INSTRUCTIONS

1. Use isolation transformer if available. If not, connect a .1 mfd. condenser in series with low side of signal generator and B-neutral
2. Volume control should be at maximum position. Output of signal generator should be no higher than necessary to obtain an output reading. Use an insulated screw driver for adjusting.

STEP	DUMMY ANTENNA	SIGNAL GENERATOR COUPLING	SIGNAL GENERATOR FREQUENCY	RADIO DIAL SETTING	OUTPUT METER	ADJUST	REMARKS
1	001 mfd.	High side to grid (pin 7) of V1 (12BE6). Low side to B-neutral	455 KC	Variable condenser fully open.	Across voice coil.	T2, T1 (A3, A4, A1, A2)	Adjust for maximum output.
2		Form loop of several turns and radiate signal into receiver	1620 KC	"	Across voice coil.	Trimmer C-4 (Osc.)	Adjust for maximum output.
3		"	1400 KC	Tune for maximum output.	Across voice coil.	Trimmer C-2 (Ant.)	Adjust for maximum output.

RESISTANCE READINGS FOR CHASSIS 120170-B

SYMBOL	TUBE	PIN 1	PIN 2	PIN 3	PIN 4	PIN 5	PIN 6	PIN 7
V-1	12BE6	23K	.5	12	24	1500*	1500*	4 MEG
V-2	12BA6	18	0	24	36	1500*	1500*	120
V-3	12AT6	6 MEG	0	0	12	500K	0	470*
V-4	50C5	150	470 K	36	90	470K	1500*	210*
V-5	35W4	N.C.	N.C.	90	120	135	115	0*

* Resistances measured to pin 7 of rectifier 35W4 (B+).

VOLTAGE READINGS ON SCHEMATIC DIAGRAM

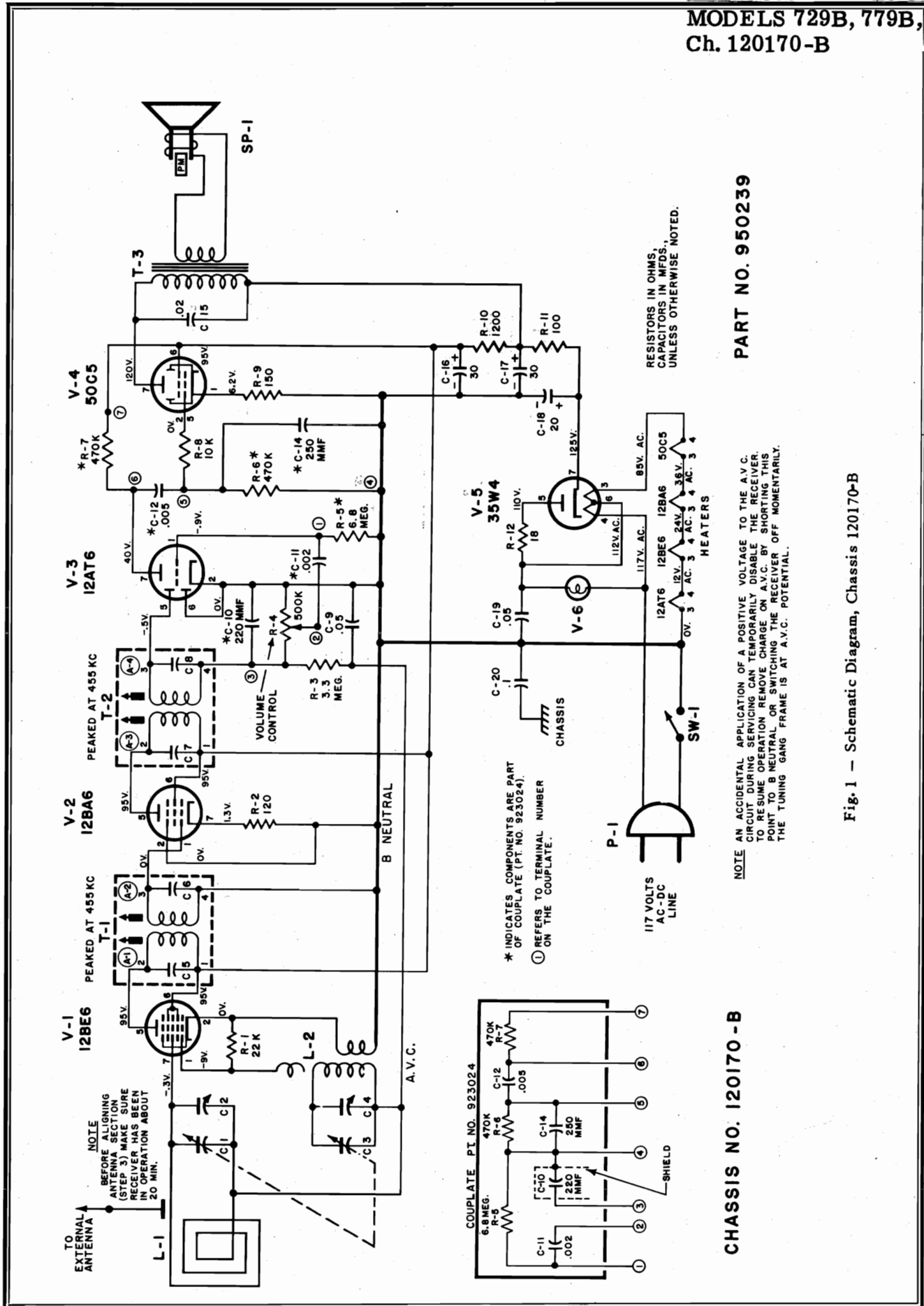

MODELS 729B, 779B,
Ch. 120170-B

CHASSIS PARTS LIST (Chassis 120170-B)

SYM-BOL	PART NO.	DESCRIPTION	LIST PRICE	SYM-BOL	PART NO.	DESCRIPTION	LIST PRICE
C-1	,900092	Variable Capacitor - R.F. Section	3.30	R-1	Pt. of L-2	22,000 ohm Carbon	
C-2	PT. of C-1	Trimmer - R.F. Section		R-2	340272	120 ohm Carbon 1/2W. ±10%	.10
C-3	PT. of C-1	Variable Capacitor - Oscillator Sec.		R-3	351332	3.3 megohm Carbon 1/2W. ±20%	.06
C-4	PT. of C-1	Trimmer - Oscillator Section		R-4	390205	500,000 ohm volume control	1.30
C-5	PT. of T-1			R-5	Part of 6.8 megohm R.C. Coupling Unit		
C-6	PT. of T-1			R-6		470,000 ohm	
C-7	PT. of T-2			R-7		923024	470,000 ohm
C-8	PT. of T-2			R-8	350732	10,000 ohm Carbon 1/2W. ±20%	.05
C-9	923554	.05 mf Paper 400V.	.25	R-9	340292	150 ohm Carbon 1/2W. ±10%	.10
C-10	Part of 923024	220 mmf	1.05	R-10	370512	1,200 ohm Carbon 1W. ±10%	.15
C-11		.002 mf		R-11	370252	100 ohm Carbon 1W. ±10%	.15
C-12		.005 mf		R-12	340072	18 ohm Carbon 1/2W. ±10%	.14
C-14		250 mmf		R-13	351052	220,000 ohm Carbon 1/2W. ±20%	.05
C-15	923524	.02 mf Paper 400V.	.25	SP-1	180095	Speaker - PM - 6"	4.65
C-16	925234	30 mf Electrolytic 150V.	1.40	SW-1	Pt. of R-4	Switch - Radio On-Off	
C-17	PT. of C-16	30 mf Electrolytic 150V.		X-1	555029	Terminal Strip-Speaker	
C-18	PT. of C-16	20 mf Electrolytic 150V.		T-1	720033	1st. I.F. Transformer	1.80
C-19	923554	.05 mf Paper 400V.	.25	T-2	720033	2nd. I.F. Transformer	1.80
C-20	923515	.1 mf Paper 400V.	.30	T-3	734079	Output Transformer	1.60
C-21	923524	.02 mf Paper 400V.	.25	V-1	800525	Vacuum Tube - 12BE6	
L-1	700076	Loop Antenna	1.40	V-2	800524	Vacuum Tube - 12BA6	
L-2	716076	Oscillator Coil	.75	V-3	800523	Vacuum Tube - 12AT6	
P-1	583037P	Line Cord & Plug	.55	V-4	800032	Vacuum Tube - 50C5	
P-2	580285	Lead & Pin Assembly - Speaker		V-5	800526	Vacuum Tube - 35W4	
				V-6	807000	Pilot Light - #47 Bulb	.11

Prices subject to change without notice.

CABINET PARTS LIST - CHASSIS 120170-B

PART NUMBERS		DESCRIPTION	LIST PRICE
MODEL 729B	MODEL 779B		
140483		Cabinet Body - Ivory	5.95
140483C		Cabinet Body - Cherry Red	5.95
140483D		Cabinet Body - Cerulean Blue	5.95
140483E		Cabinet Body - Forrest Green	5.95
	140548	Cabinet Body - Wood - Light Mahogany	14.00
460339	460339	Cabinet Front - for 140483, 140483C & 140548	2.50
460339A		Cabinet Front - for 140483D	2.50
460339B		Cabinet Front - for 140483E	2.50
470708	470708	Grille Assembly - Gold	.55
180095	180095	Speaker - 6"	4.65
411387	411387	Dial Light Bracket	.05
560326	560326	Baffle	.30
541187	541187	Trimount Fastener	.01
460312A		Knob - Tuning	.20
	460312B	Knob - Tuning	.20
460311	460311	Knob - Volume	.10
542280	542280	Spring - Knob	.02

Prices subject to change without notice.

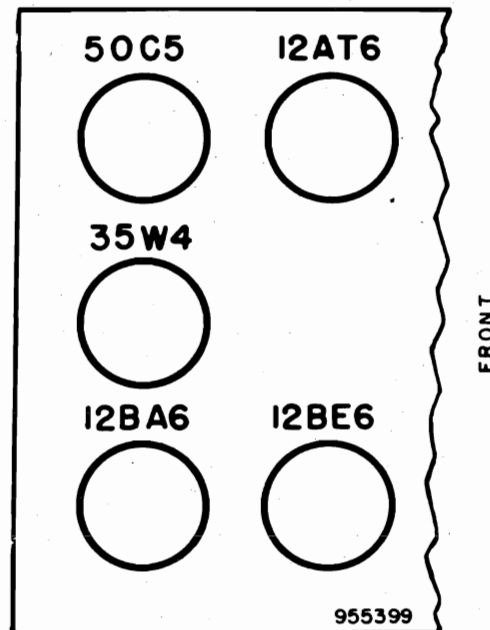
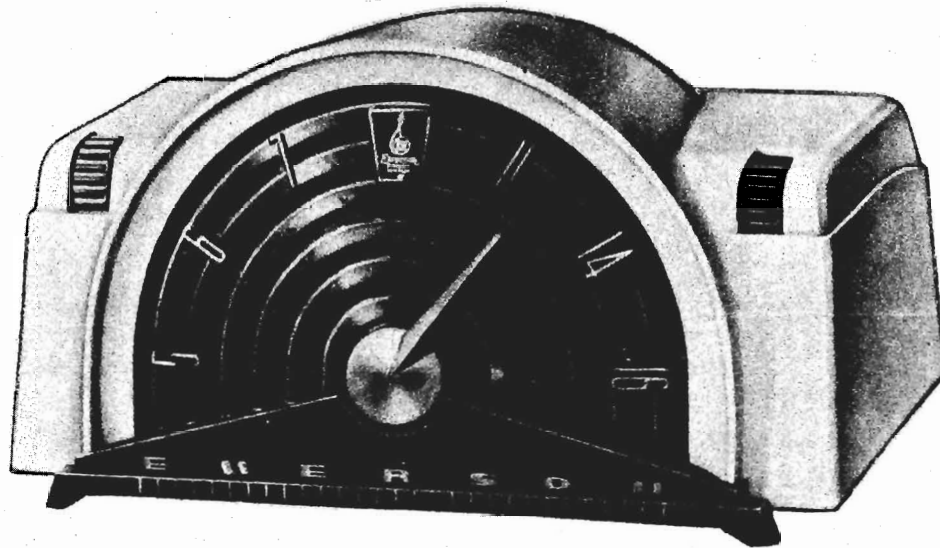

Fig. 2 - Tube Location Diagram of Chassis 120170-B



MODEL 744B
Chassis 120175-B

DESCRIPTION

TYPE: Single-band (AM) superheterodyne.

FREQUENCY RANGE: Broadcast 540-1620 kc

TYPE OF TUBES:

V-1--12BE6, converter

V-2--12BA6, i-f amplifier

V-3--12AT6, detector, a.v.c. a-f amplifier

V-4--50C5, power output

V-5--35W4, rectifier

POWER SUPPLY: A.C. or D.C.

VOLTAGE RATING: 105-125 volts.

POWER CONSUMPTION: 30 watts.

CURRENT DRAIN: 0.24 amp. at 117 volts a.c.

GENERAL NOTES

1. If replacements are made or the wiring disturbed in the r-f section of the circuit, the receiver should be carefully realigned.
2. In operating the receiver on d.c., it may be necessary to reverse the line plug for correct polarity.
3. Model 744B has a self contained antenna and normally does not require an additional antenna connection. For installation in a location where reception is weak, connect the outside antenna to the colored lead at the bottom of the cabinet. Do not use ground connection.
4. The self contained loop antenna has directional properties. It is important therefore, once the station is tuned in that the cabinet be rotated back and forth through a quarter of a circle (90 degrees), and left at a position where the station is received with maximum volume.

MODEL 744B,
Ch. 120175-B

CONDITIONS FOR VOLTAGE AND RESISTANCE READINGS

1. Voltages indicated are positive d.c., resistances are in ohms, unless otherwise indicated.
2. Measurements made with voltohmmyst or equivalent.
3. Line voltage maintained at 117 volts a.c. for voltage measurements.
4. Socket connections are shown as bottom views, with measurements from pin to common negative.
5. Volume control at maximum; no signal applied for voltage measurements.
6. Nominal tolerance on component values makes possible a variation of $\pm 15\%$ in voltage and resistance readings.
7. NC denotes no connection, K is kilohms, MEG is megohms. Resistances marked * are measured to pin 7 of rectifier 35W4 (B+).

ALIGNMENT INSTRUCTIONS

1. Use isolation transformer if available. If not, connect a .1 mfd. condenser in series with low side of signal generator and B neutral.
2. Volume control should be at maximum position. Output of signal generator should be no higher than necessary to obtain an output reading. Use an insulated screw driver for adjusting.

STEP	DUMMY ANTENNA	SIGNAL GENERATOR COUPLING	SIGNAL GENERATOR FREQUENCY	RADIO DIAL SETTING	OUTPUT METER	ADJUST	REMARKS
1	.001 mfd.	High side to grid (pin 7) of V1 (12BE6). Low side to B neutral	455 KC	Variable condenser fully open.	Across voice coil.	T2, T1 (A3, A4, A1, A2)	Adjust for maximum output.
2		Form loop of several turns and radiate signal into receiver	1620 KC	"	Across voice coil.	Trimmer C-4 (Osc.)	Adjust for maximum output.
3		"	1400 KC	Tune for maximum output.	Across voice coil.	Trimmer C-2 (Ant.)	Adjust for maximum output.

RESISTANT READINGS FOR CHASSIS 120175-B

SYMBOL	TUBE	PIN 1	PIN 2	PIN 3	PIN 4	PIN 5	PIN 6	PIN 7
V-1	12BE6	23K	.5	12	24	1500*	1500*	4 MEG
V-2	12BA6	3.2 MEG	0	24	36	1500*	1500*	120
V-3	12AT6	6 MEG	0	0	12	500K	0	470*
V-4	50C5	150	470 K	36	90	N.C.	1500*	210*
V-5	35W4	N.C.	N.C.	90	120	135	115	0*

* Resistances measured to pin 7 of rectifier 35W4 (B+).

VOLTAGE READINGS ON SCHEMATIC DIAGRAM

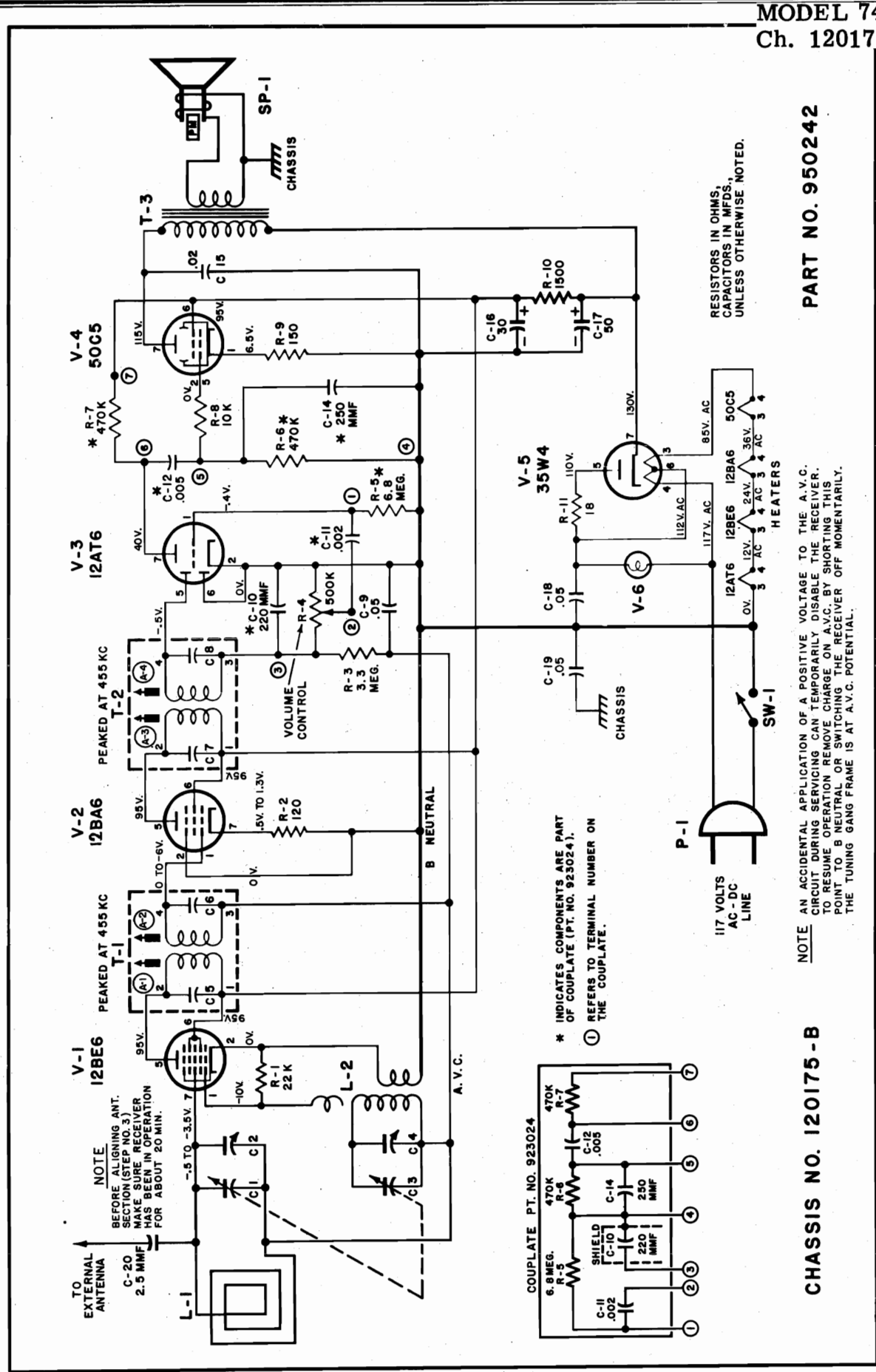

Fig. 1 - Schematic Diagram, Chassis 120175-B

MODEL 744B,
Ch. 120175-B

CHASSIS PARTS LIST (Chassis 120175-B)

SYM- BOL	PART NO.	DESCRIPTION	LIST PRICE	SYM- BOL	PART NO.	DESCRIPTION	LIST PRICE
C-1	900093	Variable Capacitor - r.f. Section	3.50	R-4	390221	500,000 ohm Volume Control	1.00
C-2	Pt. of C-1	Trimmer - r.f. Section		R-5	Part	6.8 megohm	
C-3	Pt. of C-1	Variable Capacitor - Oscillator Section		R-6	of	470,000 ohm	
C-4	Pt. of C-1	Trimmer - Oscillator Section		R-7	923024	R.C. Coupling Unit	
C-5	Pt. of T-1			R-8	350732	Carbon 1/2 w ±20%	.05
C-6	Pt. of T-1			R-9	340292	Carbon 1/2 w ±10%	.10
C-7	Pt. of T-2			R-10	380532	Carbon 1 w ±20%	.16
C-8	Pt. of T-2			R-11	340072	Carbon 1/2 w ±10%	.14
C-9	923554	.05 mf. Paper 400V	.25				
C-10	Part	220 mmf. R. C. Coupling Unit	1.05	SP-1	180101	Speaker - PM-5"	3.55
C-11	of						
C-12	923024	.002 mf.					
C-14		.005 mf. 250 mmf.		SW-1	Pt. of R-4	Switch - On-Off	
C-15	923524	.02 mf. Paper 400V	.25				
C-16	925235	30 mf. Electrolytic 150V	1.45	T-1	720033	1st I.F. Transformer	1.80
C-17	Pt. of C-16	50 mf. Electrolytic 150V		T-2	720033	2nd I.F. Transformer	1.80
C-18	923554	.05 mf. Paper 400V	.25	T-3	734087	Output Transformer	2.00
C-19	923554	.05 mf. Paper 400V	.25				
C-20	Pt. of L-1	2.5 mmf. Coupling Capacitor		V-1	800525	Vacuum Tube - 12BE6	
L-1	700083	Loop Antenna Assembly	1.60	V-2	800524	Vacuum Tube - 12BA6	
L-2	716075	Oscillator Coil	.95	V-3	800523	Vacuum Tube - 12AT6	
P-1	583045P	Line Cord & Plug	.55	V-4	800032	Vacuum Tube - 50C5	
R-1	Pt. of L-2	22,000 ohm Carbon 1/2 w ±10%	.10	V-5	800526	Vacuum Tube - 35W4	
R-2	340272	120 ohm Carbon 1/2 w ±20%	.14	V-6	807000	Pilot Light - #47 Bulb	
R-3	351332	3.3 megohm Carbon					

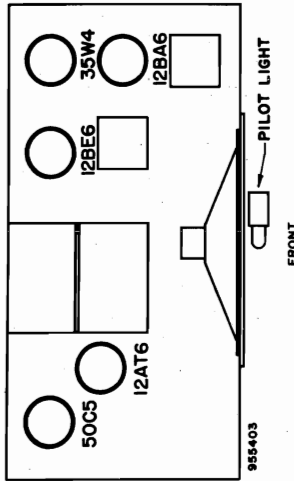

Fig. 3 Tube Location Diagram of Chassis 120175-B

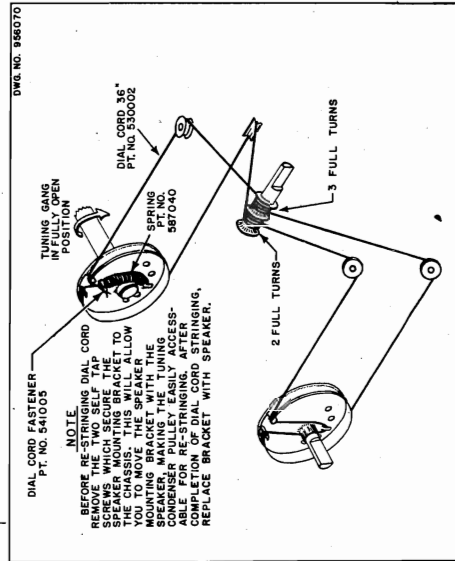
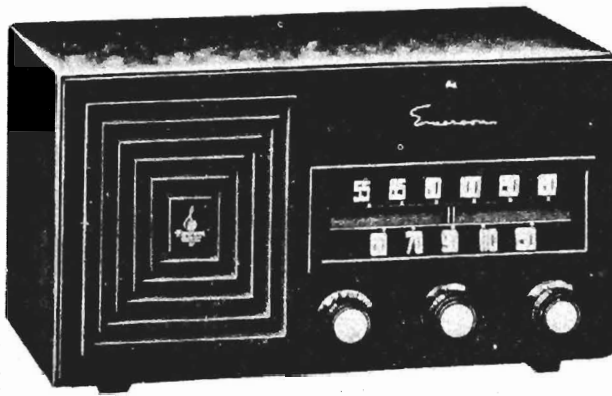

Fig. 2 Dial Cord Stringing for Model 744B

CABINET PARTS LIST (Model 744B)

PART NO. MODEL 744B	DESCRIPTION	LIST PRICE
140482	Cabinet - Ebony	3.70
140482A	Cabinet - Flame	3.70
460338	Dial & Grille	2.25
460417	Knob	.15
541170	Spring - Knob & Pointer	.03
460382	Pointer	..20
470200	Felt Foot Assembly	.10
635042	Jewel	.12
411443	Heat Shield	
541139	Fastener - Shield	.01

Prices subject to change without notice.



MODEL 641B



MODEL 756B

DESCRIPTION

TYPE: Single band (AM) superheterodyne

FREQUENCY RANGE: 540-1620 KC.

TYPES OF TUBES:

- V-1-6BJ6 converter
- V-2-6BJ6 oscillator
- V-3-6BJ6 1st i.f. amplifier
- V-4-6BJ6 2nd i.f. amplifier
- V-5-12AT6 Detector, a.v.c., a-f amplifier
- V-6-50C5 Power output
- V-7-35W4 Rectifier

POWER SUPPLY: A.c. or d.c.

VOLTAGE RATING: 115 volts

POWER CONSUMPTION: 30 watts

CURRENT DRAIN: 0.26 amp. at 117 volts a.c.

GENERAL NOTES

1. If replacements are made or the wiring disturbed in the r-f section of the circuit, the receiver should be carefully realigned.
2. In operating the receiver on d.c., it may be necessary to reverse the line plug for correct polarity.
3. The receiver has a self-contained antenna, and does not require additional antenna connections. For permanent home installations, however, if it is desired to improve reception of weak stations, an additional outdoor antenna may be used. For this purpose a lead has been brought out in the rear. Use no ground connection.
4. The self-contained loop antenna operates at maximum efficiency when its position is at right angles to the broadcasting source. It is important, therefore, once the station is tuned in, to rotate the cabinet back and forth through a quarter of a circle (90 degrees), leaving it at the position where the station is received with maximum volume.

MODELS 641B, 756B,
Ch. 120125-B

INSTRUCTIONS FOR VOLTAGE AND RESISTANCE READINGS

1. Voltage readings are in d.c. volts and resistance readings in ohms unless otherwise specified.
2. A.C. and D.C. measurements are taken with a V.T.V.M.
3. Measured values are from socket pin to common negative (B—).
4. Line voltage maintained at 115V A.C. for voltage readings.
5. Nominal tolerance on component values makes possible a variation of $\pm 15\%$ in voltage and resistance readings.
6. Volume control at maximum with no signal applied, for voltage measurements.

VOLTAGE READINGS FOR CHASSIS 120125-B

SYMBOL	TUBE	PIN 1	PIN 2	PIN 3	PIN 4	PIN 5	PIN 6	PIN 7
V-1	6BJ6	-1.2 DC	1 DC	18 AC	12 AC	85 DC	35 DC	0
V-2	6BJ6	-9.2 DC	0	24 AC	18 AC	85 DC	85 DC	0
V-3	6BJ6	0	1.4 DC	30 AC	36 AC	68 DC	85 DC	0
V-4	6BJ6	-1.3 DC	.65 DC	30 AC	24 AC	85 DC	85 DC	0
V-5	12AT6	-.8 DC	0	0	12 AC	0	-.65 DC	42 DC
V-6	50C5	5.4 DC	0	36 AC	80 AC	0	85 DC	100 DC
V-7	35W4	85 DC	NC	80 AC	115 AC	110 AC	110 AC	110 DC

RESISTANCE READINGS FOR CHASSIS 120125-B

SYMBOL	TUBE	PIN 1	PIN 2	PIN 3	PIN 4	PIN 5	PIN 6	PIN 7
V-1	6BJ6	4.2 meg.	1100	22	16	500,000	1 meg.	0
V-2	6BJ6	24,000	1	30	22	500,000	500,000	0
V-3	6BJ6	20	220	38	46	500,000	500,000	0
V-4	6BJ6	4.3 meg	120	38	30	500,000	500,000	0
V-5	12AT6	10 meg	0	0	16	0	550,000	1 meg.
V-6	50C5	150	400,000	46	100	400,000	500,000	500,000
V-7	35W4	500,000	NC	100	135	175	130	500,000

ALIGNMENT PROCEDURE

1. To set pointer, turn variable condenser fully closed and set pointer at mark near left end of dial backplate.
2. Use isolation transformer if available. If not, connect a 0.1 mfd. condenser in series with low side of signal generator and B minus bus.
3. Volume control should be at maximum position; output of signal generator should be not higher than necessary to obtain an output reading.
4. Use an insulated alignment screwdriver for adjusting.

STEPS	DUMMY ANTENNA	SIGNAL GENERATOR COUPLING	SIGNAL GENERATOR FREQUENCY	RADIO DIAL SETTING	METER OUTPUT	ADJUST	REMARKS
1	0.1 mfd.	High side to pin 1 (grid) of 6BJ6 (V1). Low side to B minus Bus.	455 kc	Variable condenser fully open.	Across voice coil.	A1, A2 (2nd i-f trans. T2) A3, A4 (1st i-f trans. T1)	Adjust for maximum output. If isolation transformer is not used, reduce dummy antenna to 0.001 mfd. to reduce hum modulation.
2	200 mmfd.	High side to external antenna lead. Low side to B minus Bus.	1620 kc	Variable condenser fully open.	Across voice coil.	A5 (Trimmer cond. C5).	Adjust for maximum output.
3	200 mmfd.	High side to external antenna lead. Low side to B minus Bus.	1400 kc	Tune for maximum output.	Across voice coil.	A6 (Trimmer cond. C2).	Adjust for maximum output.

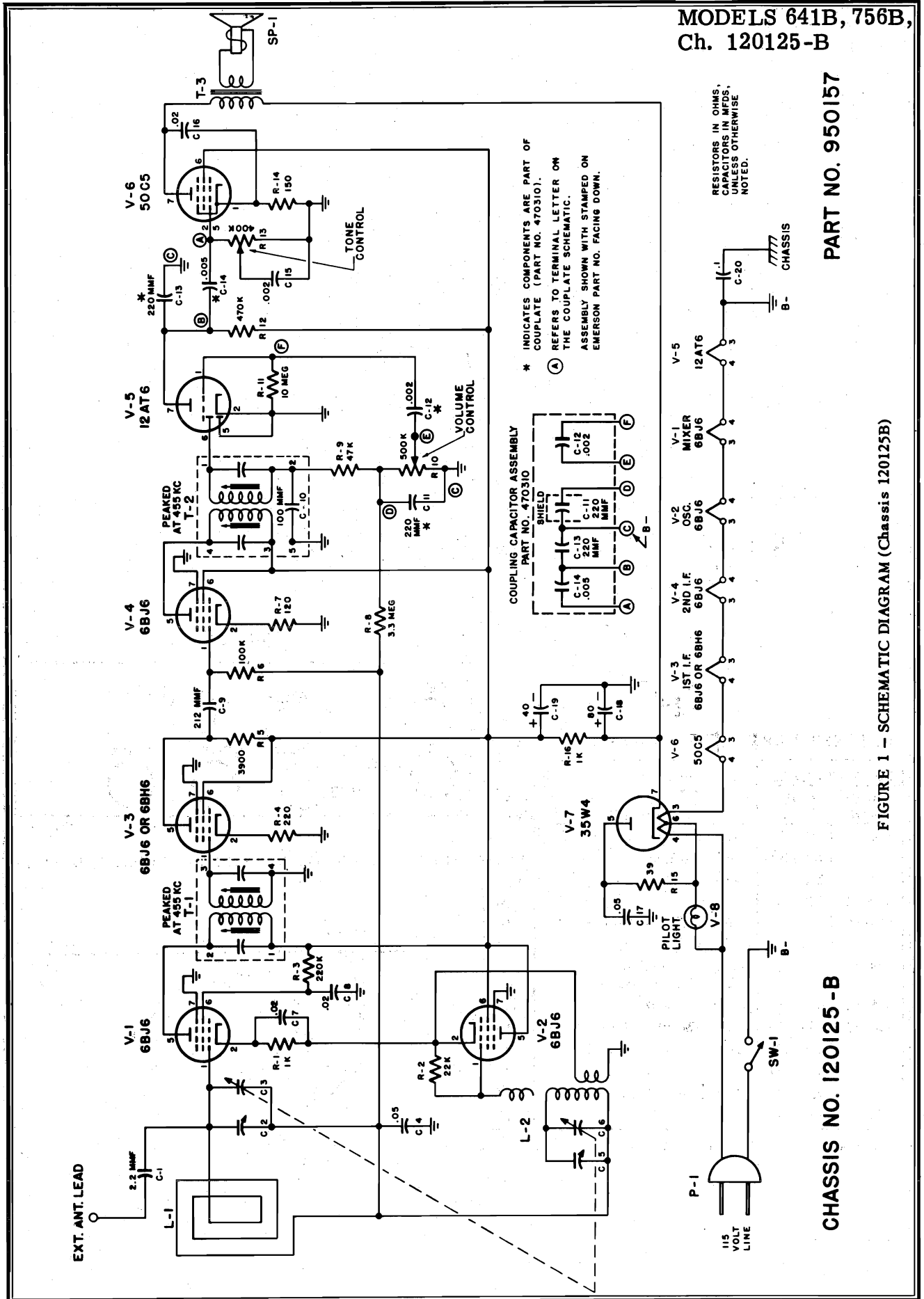

PART NO. 950157

FIGURE 1 - SCHEMATIC DIAGRAM (Chassis 120125B)

CHASSIS NO. 120125-B

* INDICATES COMPONENTS ARE PART OF
 COUPLATE (PART NO. 470310).
 (A) REFERS TO TERMINAL LETTER ON
 THE COUPLATE SCHEMATIC.
 ASSEMBLY SHOWN WITH STAMPED ON
 EMERSON PART NO. FACING DOWN.

RESISTORS IN OHMS,
 CAPACITORS IN MFD'S,
 UNLESS OTHERWISE
 NOTED.

MODELS 641B, 756B,
Ch. 120125-B

CHASSIS PARTS LIST (Chassis 120125-B)

SYM-BOL	PART NO.	DESCRIPTION	LIST PRICE	SYM-BOL	PART NO.	DESCRIPTION	LIST PRICE
C-1	PT. of L-1	2.2 mf		R-5	340632	3,900 ohm Carbon	1/4W ±10% .10
C-2	PT. of C-3	Trimmer - R.F. Section		R-6	350972	100,000 ohm Carbon	1/4W ±20% .17
C-3	900077	Variable Capacitor - R.F. Section	3.80	R-7	340272	120 ohm Carbon	1/4W ±10% .14
C-4	923554	.05 mf 400 V	.25	R-8	351332	3.3 megohm Carbon	1/4W ±20% .06
C-5	PT. of C-6	Trimmer - Oscillator Section		R-9	340892	47,000 ohm Carbon	1/4W ±10% .17
C-6	900077	Variable Capacitor - Oscillator Sec.	3.80	R-10	390152	500,000 ohm Volume Control	1.15
C-7	923524	.02 mf Paper 400 V	.25	R-11	351452	10 megohm Carbon	1/4W ±20% .14
C-8	923524	.02 mf Paper 400 V	.25	R-12	351132	470,000 ohm Carbon	1/4W ±20% .14
C-9	928104	212 mf Ceramic 500 V	.30	R-13	390157	400,000 ohm Tone Control	.70
C-10	PT. of T-2	100 mf		R-14	340292	150 ohm Carbon	1/4W ±10% .17
C-11		220 mf		R-15	370152	39 ohm Carbon	1W ±10% .15
C-12		.002 mf		R-16	370492	1,000 ohm Carbon	1W ±10% .16
C-13	470310	Coupling Capacitor Assembly		SP-1	180107	Speaker P.M. - 6 inch	4.65
C-14			220 mf				
C-15			.005 mf				
C-15	923723	.002 mf Paper 600 V	.20	SW-1	PT. of R-10	On - Off Switch	
C-16	923524	.02 mf Paper 400 V	.25	T-1	720033	1st I.F. Transformer	1.80
C-17	923554	.05 mf Paper 400 V	.25	T-2	720125	2nd I.F. Transformer	1.70
C-18	925187	80 mf Electrolytic 150 V	1.65	T-3	734061	Output Transformer	1.15
C-19	PT. of C-18	40 mf Electrolytic 150 V		V-1	800023	Vacuum Tube - 6BJ6	
C-20	923515	.1 mf Paper 600 V	.30	V-2	800023	Vacuum Tube - 6BJ6	
L-1	700054	Loop Antenna	1.55	V-3	800054or	Vacuum Tube - 6BH6	
L-2	716063	Oscillator - Coil	.95	V-3	800023	Vacuum Tube - 6BJ6	
L-3	583033P	Plug and Line Cord	.80	V-4	800023	Vacuum Tube - 6BJ6	
R-1	340492	1,000 ohm Carbon 1/4W ±10%	.17	V-5	800523	Vacuum Tube - 12AT6	
R-2	PT. of L-2	22,000 ohm		V-6	800032	Vacuum Tube - 50C5	
R-3	341052	220,000 ohm Carbon 1/4W ±10%	.17	V-7	800526	Vacuum Tube - 35W4	
R-4	340332	220 ohm Carbon 1/4W ±10%	.14	V-8	807000	Pilot Light (#47 Bulb)	.11

Prices subject to change without notice.

CABINET PARTS LIST - CHASSIS 120125-B

PART NUMBERS		DESCRIPTION	LIST PRICE
MODEL 641B	MODEL 756B		
140359	140359	Cabinet - Walnut	6.50
	140359D	Cabinet - Ebony	6.50
	140359E	Cabinet - Red	8.10
520133	520133	Crystal	.20
575649		Baffle & Grille Cloth	.50
	470739	Baffle & Grille Cloth	.50
275044	275044	Spring Grip Washer - Baffle & Crystal	.006
635031	635031	Jewel - Amber	.05
450068S	450068S	Knobs - Mottled Brown & Gold	.30
	450068E	Knobs - Ebony & Gold	.30
	450068F	Knobs - Red & Gold	.40
587011	587011	Spring Insert - Knobs	.01
575664	575664	Back	.20

Prices subject to change without notice.

FRONT

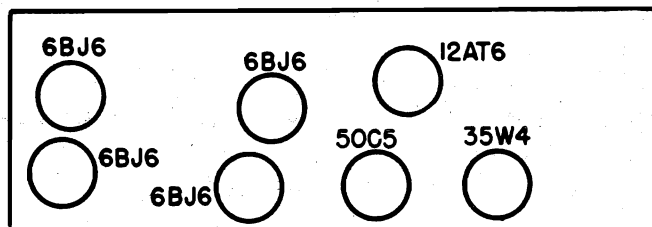

FIG. 2 TUBE LOCATION DIAGRAM FOR CHASSIS 120125-B

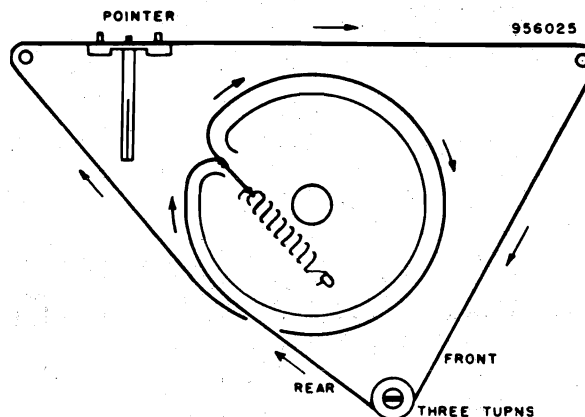

FIG. 3 DIAL CORD STRINGING FOR CHASSIS 120125-B



MODEL 783B

DESCRIPTION

TYPE: Model 783B is a Single band superheterodyne receiver with a 3-speed automatic record changer.

FREQUENCY RANGE: 540-1620 kc.

TYPE OF TUBES:

- V-1--12BE6, converter
- V-2--12BA6, i-f amplifier
- V-3--12AT6, detector, a.v.c. a-f amplifier
- V-4--50C5, power output
- V-5--35W4, rectifier

POWER SUPPLY: A.C.

VOLTAGE RATING: 105-125 volts.

RADIO POWER CONSUMPTION: 30 watts.

RADIO CURRENT DRAIN: 0.24 amp. at 117 volts a.c.

PHONO AND RADIO POWER CONSUMPTION: 50 watts

GENERAL NOTES

1. This model is equipped with an automatic record changer that plays 78, 45 and 33 1/3 R.P.M. records and shuts off automatically after the last record has been played. A flip over two needle cartridge is used for best record tracking. For more information concerning the record changer see below and parts list on back page.
2. If replacements are made or the wiring disturbed in the r-f section of Model 783B, the receiver should be carefully realigned.
3. Model 783B has a self-contained antenna and does not require an additional antenna. For permanent installations, however, if it is desired to improve reception of weak stations, an additional outdoor antenna may be connected to the colored lead at the rear of the cabinet.
4. The self-contained ferrite rod antenna has directional properties. It is important, therefore, once a station is tuned in, that the cabinet be rotated back and forth through a quarter-turn and left at that position where maximum volume is obtained.
5. **TO REMOVE CHASSIS:** Remove 4 screws on top of cabinet and take chassis cover off. Disconnect antenna, speaker and phone leads from chassis. Slide off knobs and remove chassis mounting screws (located under cabinet) and lift chassis from cabinet. In order to strip chassis, remove 3 screws holding chassis bottom shield and then unsolder rear panel and remove the 2 screws holding this panel.

3-SPEED RECORD CHANGER

General

Aside from the facts mentioned above, this changer can automatically play ten 12", twelve 10" or twelve 7" records. If desired 10" and 12" records of the same type (speed) can be intermixed.

Preliminary Adjustments: To be done before operating changer for the first time.

1. Loosen two copper screws on either side of the spindle until the changer floats freely on its mounting.
2. Place the turn table over the spindle, gently pushing the rubber rimmed wheel so that it is completely under the turn table.

MODEL 783B,
Ch. 120200-B

CONDITIONS FOR VOLTAGE AND RESISTANCE READINGS

1. Voltages indicated are positive d.c.; resistances in ohms, unless otherwise indicated.
2. Measurements made with voltohmyst or equivalent.
3. All measurements taken from pin to B neutral unless otherwise indicated.
4. Voltage measurements taken with:
 - a) Line voltage maintained at 117 volts a.c.
 - b) Radio-phono switch set for radio and volume control set for maximum.
 - c) Variable condenser fully closed and no signal applied.
5. Resistance measurements taken with:
 - a) Power line cord disconnected from outlet.
 - b) Radio-phono switch set for radio and volume control set for minimum.
6. Nominal tolerance on component values makes possible a variation of $\pm 15\%$ in voltage and resistance readings.
7. N.C. denotes no connection, K is kilohms, Meg. is megohms. Resistances marked * are measured to Pin 7 of Rectifier 35W4(B+).

ALIGNMENT INSTRUCTIONS

1. Use isolation transformer if available. If not, connect a .1 mfd. condenser in series with low side of signal generator and B neutral.
2. Volume control should be at maximum position. Output of signal generator should be no higher than necessary to obtain an output reading. Use an insulated screw driver for adjusting.

STEP	DUMMY ANTENNA	SIGNAL GENERATOR COUPLING	SIGNAL GENERATOR FREQUENCY	RADIO DIAL SETTING	OUTPUT METER	ADJUST	REMARKS
1	.1 mfd.	High side to grid (pin 7) of V1 (12BE6). Low side to B neutral	455 KC	Variable condenser fully open.	Across voice coil.	T2, T1 (A3, A4, A1, A2)	Adjust for maximum output. If isolation transformer is not used, reduce dummy ant. to .001 mfd. to reduce hum modulation.
2		Form loop of several turns and radiate signal into receiver	1620 KC	"	Across voice coil.	Trimmer C-4 (Osc.)	Adjust for maximum output.
3		"	1400 KC	Tune for maximum output.	Across voice coil.	Trimmer C-2 (Ant.)	Adjust for maximum output.

RESISTANCE READINGS FOR CHASSIS 120200-B

SYMBOL	TUBE	PIN 1	PIN 2	PIN 3	PIN 4	PIN 5	PIN 6	PIN 7
V-1	12BE6	22K	0	12	24	1500*	1500*	4.0 meg
V-2	12BA6	13 [~]	0	24	36	1500*	1500*	120 [~]
V-3	12AT6	6.8 meg	0	0	12 [~]	680K	0	470K*
V-4	50C5	150 [~]	492K	36 [~]	90 [~]	492K	1500*	210*
V-5	35W4	NC	NC	90 [~]	120 [~]	135 [~]	110 [~]	0*

* Resistances measured to Pin 7 of Rectifier 35W4 (B+).

VOLTAGE READINGS ON SCHEMATIC DIAGRAM

3-SPEED RECORD CHANGER

PLAYING 45 R.P.M. RECORDS (with large spindle hole)

In order to play such records on this changer it will be necessary to either adapt each record with a snap in center hole adapter or use a 45 R.P.M. spindle attachment. This attachment fits over the existing spindle enlarging its diameter to accommodate the above type records without the use of separate center hole adapters.

NEUTRAL (N) POSITION

When the record changer is not in use it would be advisable to place the speed control in the neutral (N) position. This position actually disengages the turn table idler wheel from the drive shaft so as not to flatten portions of the rubber rim on the idler wheel. The true neutral position (N) is somewhere between the "N" and "45 RPM" marking. When the changer is in the true neutral position the turn table will not revolve when the phono. radio is in the phono setting and the motor is turned "on". In some instances it is easier to find this neutral position while the turn table is revolving.

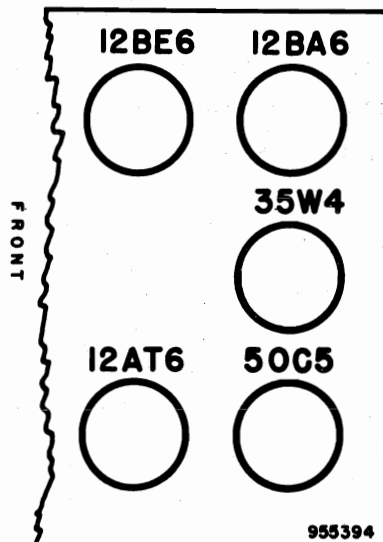

Fig. 2 Tube Location Diagram of Chassis 120200-B

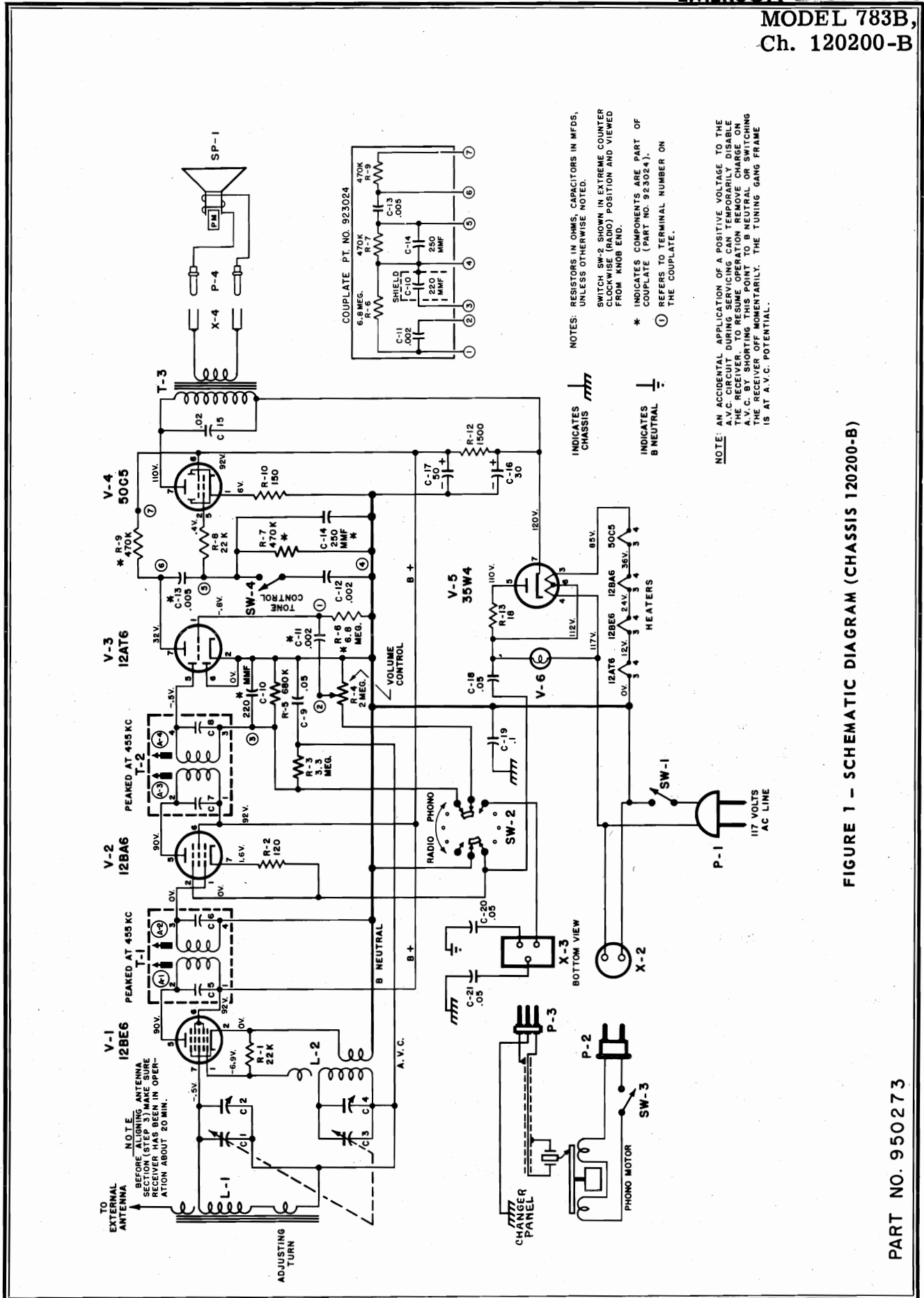

FIGURE 1 - SCHEMATIC DIAGRAM (CHASSIS 120200-B)

MODEL 783B,
Ch. 120200-B

CHASSIS PARTS LIST (Chassis 120200-B)

SYM-BOL	PART NO.	DESCRIPTION	LIST PRICE	SYM-BOL	PART NO.	DESCRIPTION	LIST PRICE
C-1	900107	Variable Capacitor - R.F. Section	3.40	R-4	390238	2 megohm Volume Control	1.00
C-2	PT. of C-1	Trimmer - R.F. Section		R-5	351172	680,000 ohm Carbon 1/2W ±20%	.05
C-3	PT. of C-1	Variable Capacitor - Oscillator Section		R-6	PT. of C-10	6.8 megohm R.C. Coupling Unit	
C-4	PT. of C-1	Trimmer - Oscillator Section		R-7	PT. of C-10	470,000 ohm R.C. Coupling Unit	
C-5	PT. of T-1			R-8	350812	22,000 ohm Carbon 1/2W ±20%	.14
C-6	PT. of T-1			R-9	PT. of C-10	470,000 ohm R.C. Coupling Unit	
C-7	PT. of T-2			R-10	340292	150 ohm Carbon 1/2W ±10%	.10
C-8	PT. of T-3			R-11	380532	1,500 ohm Carbon 1W ±20%	.16
C-9	923554	.05 mf Paper 400 V	.25	R-12	340072	18 ohm Carbon 1/2W ±10%	.14
C-10	923024	220 mmf R.C. Coupling Unit	1.05				
C-11	PT. of C-10	.002 mf R.C. Coupling Unit		SW-1	PT. of R-4	Switch - On - Off (Power)	
C-12	923723	.002 mf Paper 600 V	.20	SW-2	510097	Switch - Phono - Radio	2.10
C-13	PT. of C-10	.005 mf R.C. Coupling Unit		SW-3	PT. of Chgr.	Switch - On - Off (Phono Motor)	
C-14	PT. of C-10	250 mmf R.C. Coupling Unit		SW-4	510098	Switich - Tone Control	1.80
C-15	923524	.02 mf Paper 400 V	.25				
C-16	925218	30 mf Electrolytic 150 V	1.35	T-1	720033	1st I.F. Transformer	1.80
C-17	PT. of C-16	50 mf Electrolytic 150 V		T-2	720033	2nd I.F. Transformer	1.80
C-18	923554	.05 mf Paper 400 V	.25	T-3	734082	Output Transformer	1.35
C-19	923515	.1 mf Paper 400 V	.30				
C-20	923554	.05 mf Paper 400 V	.25	V-1	800525	Vacuum Tube - 12BE6	
C-21	923554	.05 mf Paper 400 V	.25	V-2	800524	Vacuum Tube - 12BA6	
				V-3	800523	Vacuum Tube - 12AT6	
L-1	700089	Bar Loop Antenna Ass'y - Ferrite	2.00	V-4	800032	Vacuum Tube - 50C5	
L-2	716071	Oscillator Coil	.95	V-5	800526	Vacuum Tube - 35W4	
				V-6	807000	Pilot Light (#47 Bulb)	
P-1	583047	Plug & Line Cord	.50				
P-2	585081	Plug & Power Cable (Phono Motor)	.40	X-2	PT. of Chgr.	Socket - Phono Motor	
P-3	PT. of Chgr.	Plug - Phono Pickup		X-3	508003	Socket - Phono Pickup	.10
P-4	580289	Lead & Pin Assembly - Speaker	.15	X-4	555029	Speaker Terminal Strip	.20
R-1	PT. of L-2	22,000 ohm Carbon		SP-1	180111	Speaker - PM	3.00
R-2	340272	120 ohm Carbon 1/2W ±10%	.10				
R-3	351332	3.3 megohm Carbon 1/2W ±20%	.06		819072	Record Changer - 3 Speed	

Prices subject to change without notice.

RECORD CHANGER PARTS LIST FOR 819072

PART NO.	DESCRIPTION	LIST PRICE
960776	Cartridge (flip over two needle type)	
960777	Needle (78 rpm) for cartridge	
960778	Needle (33 1/3 and 45 rpm) for cartridge	
960780	Tone Arm	1.45
960781	Record Support Assembly	1.25
960782	Speed Control Knob	.30
960783	Cartridge Control Knob	.30
960784	Strengtheners and Bracket Ass'y.	.70
960785	Hinge Arm	.70
960786	Finger and Shaft Ass'y.	.80

Prices subject to change without notice

CABINET PARTS LIST - CHASSIS 120200-B

PART NUMBERS	DESCRIPTION	LIST PRICE
MODEL 783B		
140542	Cabinet - Mahogany Table Model	55.00
819072	3-Speed Record Changer	
520163	Radio Bezel	.50
411612	Dial Plate	.50
180111	Speaker	3.00
635001	Jewel	.12
460312B	Knob - Tuning - Gold	.20
460377A	Knob - Volume - Maroon & Gold	.20
460162A	Knob - Radio - Phono and Tone Maroon & Gold	.10
542280	Spring - Knob	.02

Prices subject to change without notice

MODEL 778B,
Ch. 120199-B

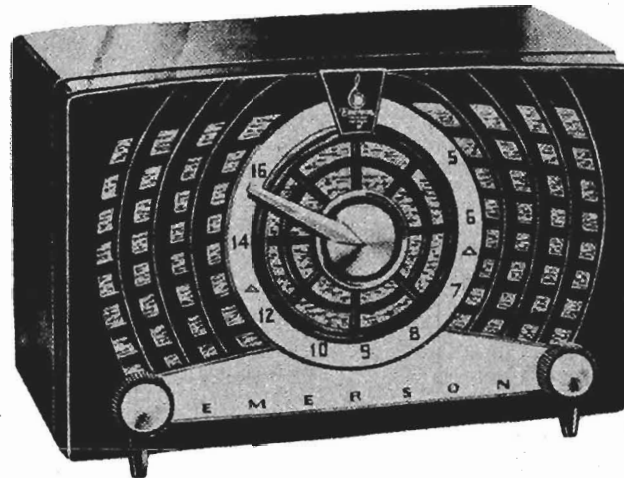

MODEL 778B
Chassis 120199-B

DESCRIPTION

TYPE: Single-band (AM) superheterodyne.

FREQUENCY RANGE: Broadcast 540-1620 kc

TYPE OF TUBES:

- V-1--12BE6, converter
- V-2--12BA6, i-f amplifier
- V-3--12AT6, detector, a.v.c. a-f amplifier
- V-4--50C5, power output
- V-5--35W4, rectifier

POWER SUPPLY: A.C. or D.C.

VOLTAGE RATING: 105-125 volts.

POWER CONSUMPTION: 30 watts.

CURRENT DRAIN: 0.24 amp. at 117 volts a.c.

GENERAL NOTES

1. If replacements are made or the wiring disturbed in the r-f section of the circuit, the receiver should be carefully realigned.
2. In operating the receiver on d.c., it may be necessary to reverse the line plug for correct polarity.
3. This model has a self-contained antenna and does not require additional antenna connections. For permanent home installations, however, if it is desired to improve reception of weak stations, an additional outdoor antenna may be used. For this purpose a lead has been brought out in the rear. Use no ground connection.
4. The self-contained loop antenna operates at maximum efficiency when its position is pointing to the broadcasting source. It is important, therefore, once the station is tuned in, to rotate the cabinet back and forth through a quarter of a circle (90 degrees), leaving it at the position where the station is received with maximum volume.

MODEL 778B,

Ch. 120199-B CONDITIONS FOR VOLTAGE AND RESISTANCE READINGS

1. Voltages indicated are positive d.c., resistances in ohms, unless otherwise indicated.
2. Measurements made with volttohyst or equivalent.
3. All measurements taken from pin to B neutral unless otherwise indicated.
4. Voltage measurements taken with:
 - a) Line voltage maintained at 117 volts a.c.
 - b) Volume control set for maximum volume.
 - c) Variable condenser fully closed and no signal applied.
5. Resistance measurements taken with:
 - a) Power line cord disconnected from outlet.
 - b) Volume control set for maximum volume.
6. Nominal tolerance on component values makes possible a variation of $\pm 15\%$ in voltage and resistance readings.
7. N.C. denotes no connection, K is kilohms, Meg. is megohms. Resistances marked * are measured to Pin 7 of Rectifier 35W4 (B+).

ALIGNMENT INSTRUCTIONS

1. Use isolation transformer if available. If not, connect a .25 mfd. condenser in series with low side of signal generator and B neutral.
2. Volume control should be at maximum position. Output of signal generator should be no higher than necessary to obtain an output reading. Use an insulated screw driver for adjusting.

STEP	DUMMY ANTENNA	SIGNAL GENERATOR COUPLING	SIGNAL GENERATOR FREQUENCY	RADIO DIAL SETTING	OUTPUT METER	ADJUST	REMARKS
1	.005 mfd.	High side to grid (pin 7) of V1 (12BE6). Low side to B-neutral (See Alignment Note).	455 KC	Variable condenser fully open.	Across voice coil.	T2, T1 (A3, A4, A1, A2)	Adjust for maximum output.
2		Form loop of several turns and radiate signal into receiver	1620 KC	"	Across voice coil.	Trimmer C-4 (Osc.)	Adjust for maximum output.
3		"	1400 KC	Tune for maximum output.	Across voice coil.	Trimmer C-2 (Ant.)	Adjust for maximum output.

RESISTANCE READINGS FOR CHASSIS 120199-B

SYMBOL	TUBE	PIN 1	PIN 2	PIN 3	PIN 4	PIN 5	PIN 6	PIN 7
V-1	12BE6	22K	0.4 \sim	12 \sim	24 \sim	1500*	1500*	4 MEG
V-2	12BA6	4 MEG	0 \sim	24 \sim	36 \sim	1500*	1500*	120 \sim
V-3	12AT6	6.8 MEG	0 \sim	0 \sim	12 \sim	500K	0 \sim	470K*
V-4	50C5	150 \sim	480K	36 \sim	85 \sim	480K	1500*	180*
V-5	35W4	NC	NC	85 \sim	110 \sim	130 \sim	112 \sim	0*

*Resistance measured to Pin 7 of Rectifier 35W4 (B+).

VOLTAGE READINGS ON SCHEMATIC DIAGRAM

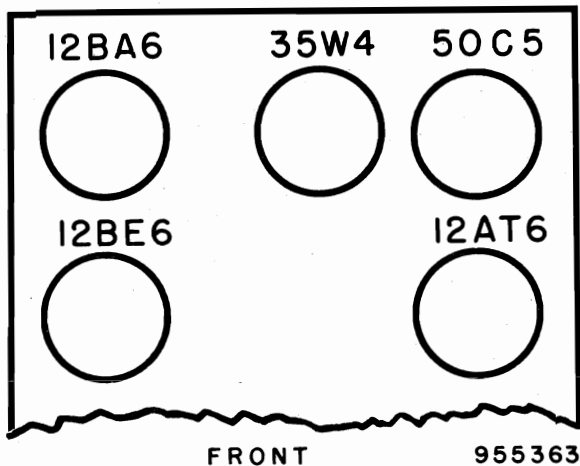

Fig. 2 - Tube Location Diagram of Chassis 120199-B

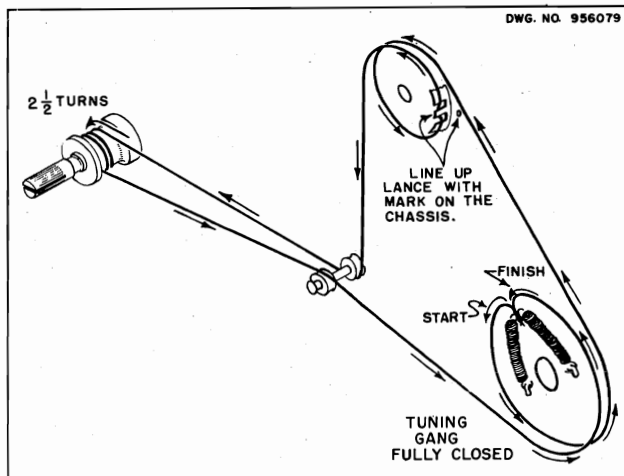

Fig. 3 - Dial Cord String for Chassis 120199-B

PART NO. 950270

CHASSIS NO. 120199 - B

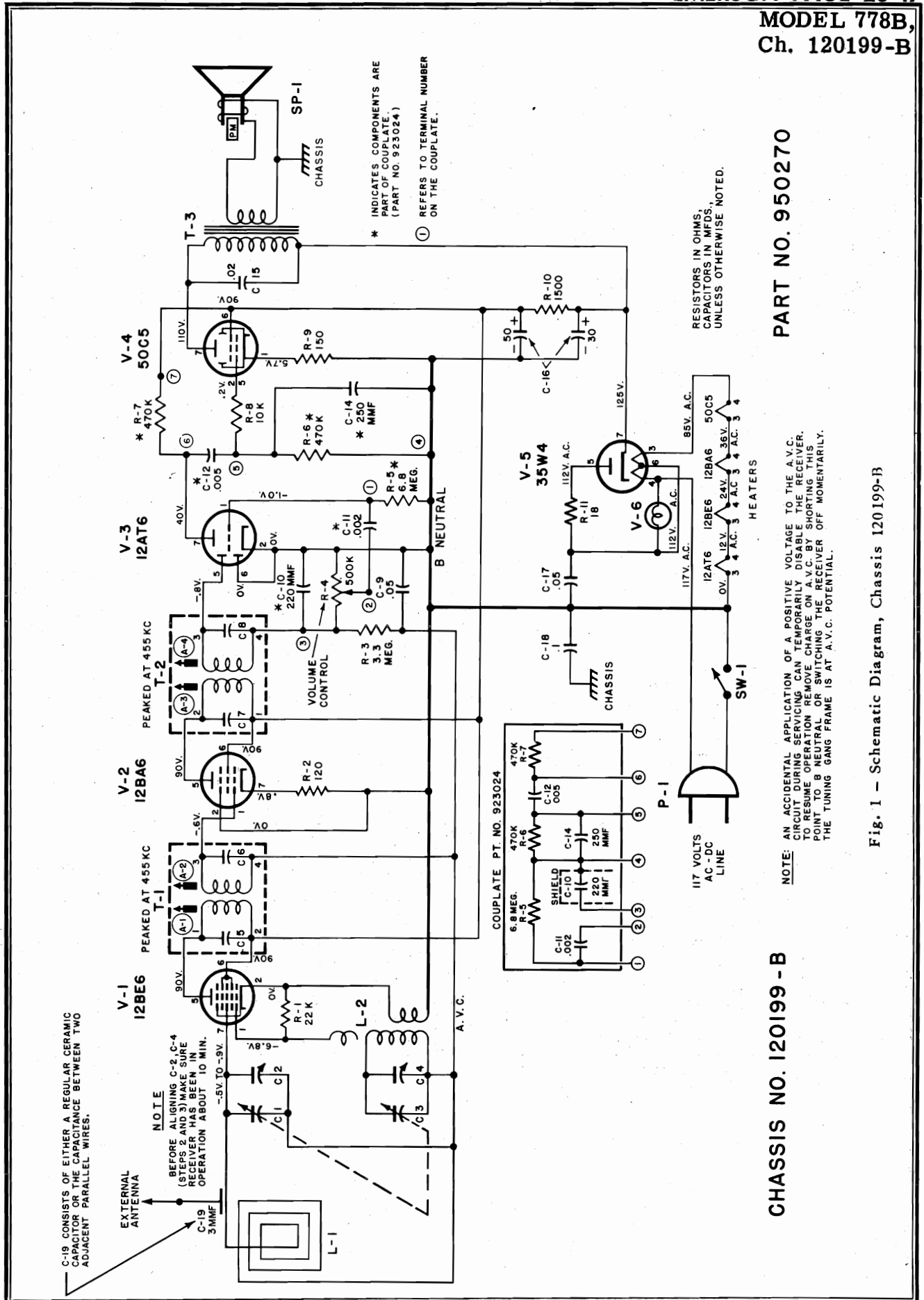

Fig. 1 - Schematic Diagram, Chassis 120199-B

MODEL 778B,
Ch. 120199-B

CHASSIS PARTS LIST (Chassis 120199-B)

SYM-BOL	PART NO.	DESCRIPTION	LIST PRICE	SYM-BOL	PART NO.	DESCRIPTION	LIST PRICE
C-1	900105	Variable Capacitor - R.F. Section	3.40	R-1	PT.of L-2	22,000 ohm Carbon	
C-2	PT.of C-1	Trimmer - R.F. Section		R-2	340272	120 ohm Carbon ½W. ±10%	.10
C-3	PT.of C-1	Variable Capacitor - Oscillator Sec.		R-3	351332	3.3 megohm Carbon ½W. ±20%	.06
C-4	PT.of C-1	Trimmer - Oscillator Section		R-4	390062	500,000 ohm Volume Carbon	.90
C-5	PT.of T-1			R-5	PART	6.8 megohm	
C-6	PT.of T-1			R-6	OF	470,000 ohm R.C. Coupling Unit	
C-7	PT.of T-2			R-7	923024	470,000 ohm	
C-8	PT.of T-2			R-8	350732	10,000 ohm Carbon ½W. ±20%	.05
C-9	923554	.05 mf Paper 400V.	.25	R-9	340292	150 ohm Carbon ½W. ±10%	.10
C-10		220 mmf		R-10	380532	1,500 ohm Carbon 1W. ±20%	.16
C-11	PART	.002 mf		R-11	340072	18 ohm Carbon ½W. ±10%	.14
C-12	OF	.005 mf R.C. Coupling Unit	1.05	SP-1	180111	Speaker - PM - 4"	3.00
C-14		250 mmf		SW-1	PT.of R-4	On-Off Switch	
C-15	923524	.02 mf Paper 400V.	.25	T-1	720033	1st I.F. Transformer	1.80
C-16	925218	30-50 mf Electrolytic 150V.	1.35	T-2	720033	2nd I.F. Transformer	1.80
C-17	923554	.05 mf Paper 400V.	.25	T-3	734089	Output Transformer	1.55
C-18	923515	.1 mf Paper 400V.	.30	V-1	800525	Vacuum Tube - 12BE6	
C-19	PT.of L-1	3 mmf		V-2	800524	Vacuum Tube - 12BA6	
L-1	700088	Loop Antenna	1.40	V-3	800523	Vacuum Tube - 12AT6	
L-2	716076	Oscillator Coil	.75	V-4	800032	Vacuum Tube - 50C5	
P-1	583037P	Plug & Line Cord	.55	V-5	800526	Vacuum Tube - 35W4	
				V-6	807000	Pilot Light - No. 47 Bulb	.11

Prices subject to change without notice.

CABINET PARTS LIST - Chassis 120199-B

PART NOS.	DESCRIPTION	LIST PRICE	PART NOS.	DESCRIPTION	LIST PRICE
MODEL 778B			MODEL 778B		
140547	Cabinet - Ebony	4.05	411595	Insert - Gold	.70
140547A	Cabinet - Ivory	6.25	411596	Dial Ring - Gold	.95
140547B	Cabinet - Cherry Red	6.25	575934	Baffle	.90
140547C	Cabinet - Forest Green	6.25	575936	Back	.20
460162-S	Knobs -		541187	Trimount Fastener	.01
	Tuning & Volume - Gold	.10	542280	Compression Spring	.02
460382	Pointer - Gold	.20	635031	Jewel - Amber	.05

Prices subject to change without notice.

For best results replacements should be made with genuine Emerson parts and genuine Emerson tubes.

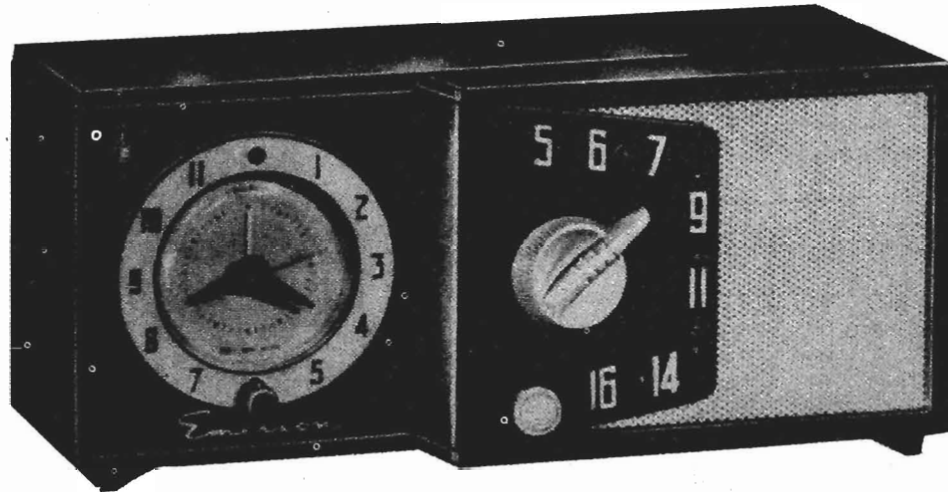
MODEL 788B,
Ch. 120201-BMODEL 788B
Chassis 120201B

DESCRIPTION

TYPE: Single-band (AM) superheterodyne, with clock timer.

FREQUENCY RANGE: Broadcast 540 - 1620 kc

TYPE OF TUBES:

- V-1 - 12BE6, converter
- V-2 - 12BA6, i-f amplifier
- V-3 - 12AT6, detector, a.v.c. a-f amplifier
- V-4 - 50C5, power output
- V-5 - 35W4, rectifier

POWER SUPPLY: A.C. 60 cycles only

VOLTAGE RATING: 105-125 volts.

POWER CONSUMPTION: 32 watts.

CURRENT DRAIN: 0.23 amp. at 117 volts a.c.

GENERAL NOTES

1. If replacements are made or the wiring disturbed in the r-f section of the circuit, the receiver should be carefully realigned.
2. Detailed information for the clock timer used in this model is described on page 3.
3. Model 788B has a self-contained antenna and does not require additional antenna connections.
4. The self-contained bar type antenna operates at maximum efficiency when it is positioned properly with respect to the broadcasting source. Because of this fact, reception can be improved in a relatively weak or shielded signal area, merely by slowly rotating the cabinet through a quarter of a circle (90 degrees). The cabinet should be left in the position where the station is received with maximum volume.



EMERGENCY CIVILIAN DEFENSE BROADCASTS

During a national emergency the low frequency stations will all shift their operating frequencies to 640 KC while the high frequency stations shift to 1240 KC. The stations in each group will then be keyed on the air so that each one will transmit for a certain number of seconds. This will prevent the enemy from homing in on any one station since the signals will be constantly coming from a different direction. This system is called CONELRAD, meaning Control of Electromagnetic Radiation. The model 788B has two  symbols imprinted on the dial face at these frequencies (640 K.C., and 1240 K.C.).

MODEL 788B,
Ch. 120201-B

CONDITIONS FOR VOLTAGE AND RESISTANCE READINGS

1. Voltages indicated are positive d.c., resistances in ohms, unless otherwise indicated.
2. Measurements made with voltohmmyst or equivalent.
3. All measurements taken from pin to B neutral unless otherwise indicated.
4. Voltage measurements taken with:
 - a) Line voltage maintained at 117 volts a.c. only.
 - b) Radio switch knob (located on front of clock timer) turned to "on" and volume control set for maximum.
 - c) Variable condenser fully closed and no signal applied.
5. Resistance measurements taken with:
 - a) Power line cord disconnected from outlet.
 - b) Radio switch knob (located on front of clock timer) turned to "on" and volume control set for minimum.
6. Nominal tolerance on component values makes possible a variation of $\pm 15\%$ in voltage and resistance readings.
7. N.C. denotes no connection, K is kilohms, Meg. is megohms. Resistances marked * are measured to Pin 7 of Rectifier 35W4(B+).

ALIGNMENT INSTRUCTIONS

1. Use isolation transformer if available. If not, connect a .25 mfd. condenser in series with low side of signal generator and B neutral.
2. Volume control should be at maximum position. Output of signal generator should be no higher than necessary to obtain an output reading. Use an insulated screw driver for adjusting.

STEP	SIGNAL GENERATOR COUPLING	SIGNAL GENERATOR FREQUENCY	RADIO DIAL SETTING	OUTPUT METER	ADJUST	REMARKS
1	High side through .005 MFD to grid (pin 7) of V-1 (12BE6). Low side to B neutral. See alignment Ntc No. 1.	455 KC	Variable condenser fully open.	Across voice coil.	T-2, T-1 (A-3, A-4 A-1, A-2)	Adjust for maximum output.
2	Form loop of several turns and radiate signal into receiver	1630 KC	Variable condenser fully open.	Across voice coil.	Trimmer C-4 (OSC.)	Adjust for maximum output.
3	Form loop of several turns and radiate signal into receiver	1400 KC	Tune for Max-output.	Across voice coil.	Trimmer C-2 (ANT.)	Adjust for maximum output.

The following step is normally not required unless the bar loop antenna has been serviced or replaced in the field. Before proceeding with this adjustment, the chassis must be turned "on" and placed in its cabinet for a period of at least 30 minutes so that the bar loop will have reached its normal operating temperature. Remove the chassis and proceed as follows:

4	Form loop of several turns and radiate signal into receiver	600 KC	Tune for Max. output.	Across voice coil.	Ant. bar loop adjusting turns	Using slack wire (see schematic) add from one to two turns to bar loop for maximum meter reading. If reading goes down when turns are added, reverse the direction of the added turn (aiding or bucking). Repeat step No. 2.
---	---	--------	-----------------------	--------------------	-------------------------------	--

NOTE: Do not touch bar loop ant. when checking meter reading.

RESISTANCE READINGS FOR CHASSIS 120201-B

SYMBOL	TUBE	PIN 1	PIN 2	PIN 3	PIN 4	PIN 5	PIN 6	PIN 7
V-1	12BE6	22K	4	12 Ω	24 Ω	* 1.5 K	* 1.5 K	3.8 meg.
V-2	12BA6	15 Ω	0	24 Ω	36 Ω	* 1.5 K	* 1.5 K	120 Ω
V-3	12AT6	6.8 Ω	0	0	12 Ω	.5 meg.	0	* 470 K
V-4	50C5	150	480 K	36 Ω	85 Ω	480 K	* 1.5 K	* 190 Ω
V-5	35W4	NC	NC	85 Ω	120 Ω	138	112 Ω	* 0

* Resistance measured to Pin 7 of rectifier 35W4 (B+)

VOLTAGE READINGS ON SCHEMATIC DIAGRAM

CLOCK TIMER

The clock runs immediately and continuously when set is plugged into a 117V 60 cycle A.C. outlet.

TIME SET KNOB (Located at rear of clock timer)

- a) To set time (hour and minute hands) pull knob out and turn in the direction indicated by arrow.
- b) To set Radio Alarm (time radio goes on automatically) push knob in and turn in the direction indicated by arrow to the desired time.

CAUTION: When using this time set knob, be sure to always turn in the direction indicated by the arrow.

RADIO SWITCH KNOB (Located on front of clock timer). This knob switches radio "on" or "off" or when switch to "auto" will automatically turn the radio on at the time indicated by the radio alarm set hand. (see step 'b' above)

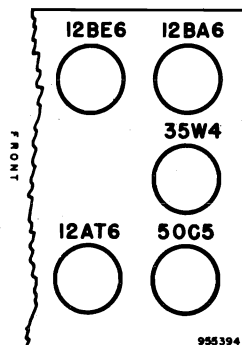

Fig. 2 Tube Location Diagram of Chassis 120201-B

MODEL 788B,
120201-B

CHASSIS PARTS LIST - CHASSIS 120201-B

SYM-BOL	PART NO.	DESCRIPTION	LIST PRICE	SYM-BOL	PART NO.	DESCRIPTION	LIST PRICE	
G-1	900106	Variable Capacitor - R.F.Section	\$3.35	R-1	PT. of L-2	22,000 Ohm Carbon	\$.10	
G-2	PT. of C-1	Trimmer - R.F.Section		R-2	340272	120 Ohm Carbon 1/2 W. ± 10%		
G-3	PT. of C-1	Variable Capacitor - Oscillator Section		R-3	351332	3.3 Megohm Carbon 1/2W. ± 20%		
G-4	PT. of C-1	Trimmer - Oscillator Section		R-4	390236	500,000 Ohm Volume Control		
G-5	PT. of T-1			R-5)	Part	6.8 Megohm)		
G-6	PT. of T-1			R-6)	of	470,000 Ohm) R.C.Coupling Unit		
G-7	PT. of T-2			R-7)	923024	470,000 Ohm)		
G-8	PT. of T-2			R-8	350732	10,000 Ohm Carbon 1/2W. ± 20%		.05
G-9	923554	.05 MF Paper 400V		.25	R-9	340292		150 Ohm Carbon 1/2W. ± 10%
G-10)		220 MMF)	1.05	R-10	380532	1,500 Ohm Carbon 1W. ± 20%	.16	
G-11)	Part	.002 MF)		R-11	340072	18 Ohm Carbon 1/2W. ± 10%	.14	
G-12)	of	.005 MF) R.C. Coupling Unit						
G-14)	923024	250 MMF)						
G-15)	923524	.02 MF Paper 400V	.25	SP-1	180115	Speaker - PM - 4" (With output Transformer)	5.00	
G-16)	925218	30-50MF) Electrolytic 150V	1.35					
G-17)	923554	.05 MF Paper 400V	.25					
G-18)	923515	.1 MF Paper 400V	.30	SW-1	PT. of M-1	On-off switch		
L-1)	700081	Bar Loop Antenna	2.00	T-1	720033	1st. L.F. Transformer	1.80	
L-2)	716071	Oscillator Coil	.95	T-2	720033	2nd. L.F. Transformer	1.80	
				T-3	PT. of SP-1	Output Transformer		
M-1)	470743	Timer - Telechron Model C-88		V-1	800525	Vacuum Tube - 12BE6		
				V-2	800524	Vacuum Tube - 12BA6		
P-1)	583049P	Plug & Line Cord	.50	V-3	800523	Vacuum Tube - 12AT6		
P-2)	585112	Plug & Lead Assembly	.30	V-4	800032	Vacuum Tube - 50C5		
				V-5	800526	Vacuum Tube - 35W4		
				X-2	500530	Radio Socket	.10	

Prices subject to change without notice.

CABINET PARTS LIST - CHASSIS 120201-B

PART NUMBERS	DESCRIPTION	LIST PRICE
MODEL 788B		
140553	Cabinet - Ebony	\$4.05
140553B	Cabinet - Ivory	5.35
140553A	Cabinet - Walnut	5.05
460326	Pointer Knob - Gold	.20
460311	Volume Knob - Clear	.10
460509	Switch Knob - Timer - Black	.05
450175	Grille - Gold	.55
542280	Spring - Knobs	.02
575939	Baffle	.25
575898	Back	.10
587329	Fastener - Baffle & Back	.02
470743	Timer - Telechron Model C-88	
277053	Fishpaper Washer - Timer	.01
520195	Crystal	.20
411635	Mounting Plate	.50

Prices subject to change without notice.

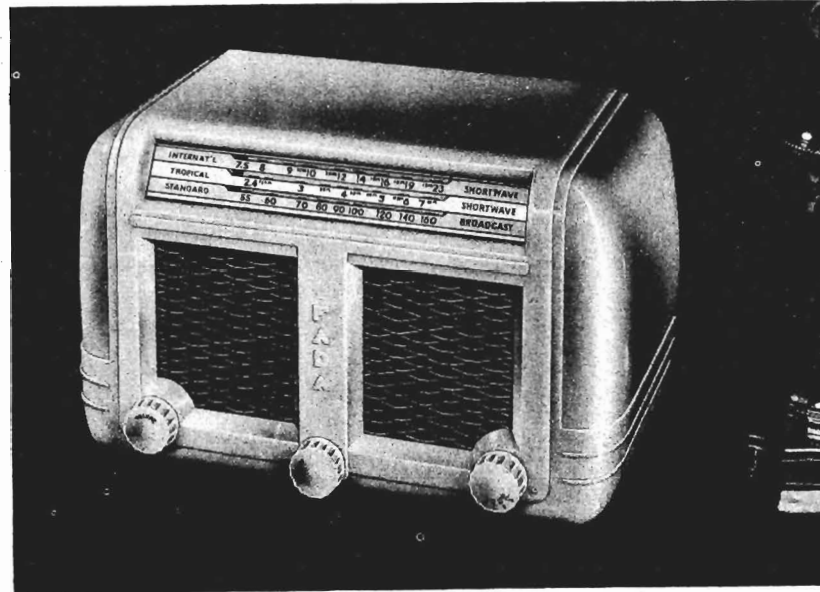

Power supply with ballast
 105-245 Volts DC 40-60 cycles AC

Power Consumption 30 Watts

Frequency Range

Standard Broadcast 530-1650 KC (566-182 meters)

Tropical Shortwave 2.3-7.6 MC (130-39.5 meters)

International Shortwave 7.4-24 MC (40.5-12.5 meters)

Tubes:

Osc. Converter 12SA7

I.F. Amplifier 12SK7

Det. Avc. A.F. 12SQ7

Power Output 50L6GT

Rectifier 35Z5GT

Ballast tubes:

117.22 105-125 volts

117.35 135-160 volts

117.36 210-245 volts

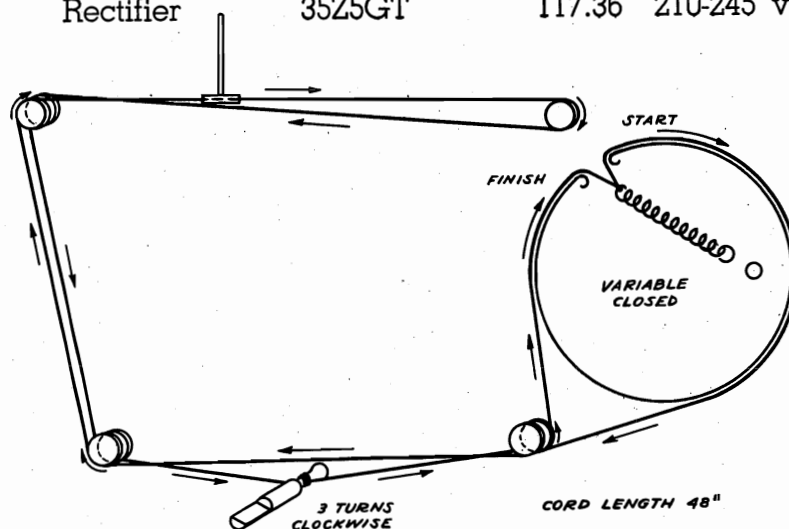

MODEL 777

ALIGNMENT PROCEDURE

The chassis may be removed from the cabinet by pulling off the knobs and, removing the four screws on the bottom.

No attempt should be made to realign the various circuits until all other causes have been checked, unless the condition is so obvious as to indicate that realignment is necessary. Then proceed as follows:

Volume Control full on.

Low range A.C. meter connected across voice coil to indicate output.

Keep signal generator attenuated so as to maintain ½ scale reading on output meter.

Make certain that dial pointer is exactly on index line (bottom left side of dial plate) when variable condenser is fully meshed. Use only mild soap and water to clean cabinet and knobs. **Never use cleaning fluids.**

Band Switch	Receiver Dial At:	Signal Generator	Dummy Antenna	Connect Signal Generator To:	Refer To Chassis Layout For Location Of Trimmers
1. Bcst	Full Open	Exactly 456 KC.	.1 MF	Control Grid 12SA7 Tube (Top) Rear Section Variable Condenser.	Adjust for Maximum Output L1, L2, L3 & L4.
2. Bcst	Full Open	Exactly 1650 KC.	200 MMF	Terminal at Rear for External Antenna and Chassis.	Adjust for Maximum Output T1
3. Bcst	Approx. 1500 KC.	Approx. 1500 KC.	200 MMF	Same	Adjust for Maximum Output T2 on Loop.
4. Bcst	Approx. 600 KC.	Approx. 600 KC.	200 MMF	Same	Adjust for Maximum Output T3 While Rocking Tuning. Repeat Steps 2, 3 & 4 if Adjustment is great.
5. Trop.	Full Open	Exactly 7.6 MC.	400 ohm	Same	Adjust for Max. Output T4 (1st. peak in) (image should appear at 8.5 MC on Signal Generator).
6. Trop.	Approx. 7.0 MC.	Approx. 7.0 MC.	400 ohm	Same	Adjust for Max. Output T5 while rocking tuning (image should appear somewhat weaker at 7.9 MC on signal generator).
7. Trop.	Approx. 2.5 MC.	Approx. 2.5 MC.	400 ohm	Terminal at Rear for External Antenna and Chassis.	Adjust for Max. Output T6 while rocking tuning. Repeat steps 5, 6 and 7 if adjustment is great.
8. Short Wave	Full Open	Exactly 24 MC.	400 ohm	Same	Adjust for Max. Output T7 (second Peak in) (image should appear at 23.1 MC on signal generator).
9. Short Wave	Approx. 22 MC.	Approx. 22 MC.	400 ohm	Same	Adjust for Max. Output T8 while rocking tuning. (image should appear somewhat weaker at 21.1 MC on signal generator).
10. Short Wave	Approx. 8 MC.	Approx. 8 MC.	400 ohm	Same	Check tracking with iron and brass wand in Ant. coil #37.108. If output more than doubles, tracking may be improved somewhat by gently dressing leads or moving osc. coil #37.109. Repeat steps 8, 9, and 10 if adjustment is great.

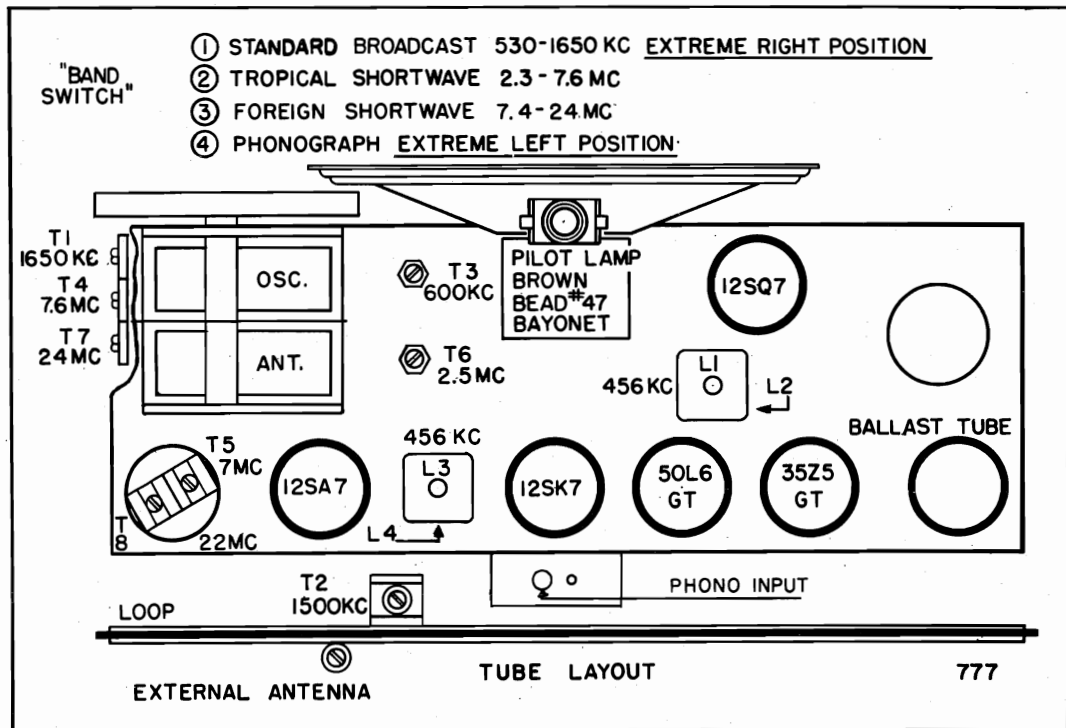

PARTS LIST

Part No.	Description	Part No.	Description
12.23	Tubular Condenser .03 Mfd. 400 V Molded	47.12	3 Band Switch
12.24	Tubular Condenser .05 Mfd. 400 V Molded	52.6	Volume Control with Switch
12.25	Tubular Condenser .1 Mfd. 400 V Molded	72.1	Power Cord
17.21	Ceramic Condenser 100 Mmf ± 20%	77.4	Dial Cord Spring
17.22	Ceramic Condenser 220 Mmf ± 20%	77.5	Dial Cord
17.45	Ceramic Condenser 1500 Mmf ± 20%	77.33	Pointer
17.75	Ceramic Condenser 2200 Mmf ± 10%	77.112	Glass Dial Scale
17.85	Mica Condenser 6800 Mmf ± 5%	92.17	Phono Plug
17.84	Ceramic Condenser 4700 Mmf ± 20%	92.18	Phono Socket
17.91	Mica Condenser 1300 Mmf ± 5%	92.19	Phono Shell
22.32	Electrolytic Condenser 30-40-20 Mfd. 150 Volts	97.46	Cabinet Bakelite (Walnut or Ivory)
27.25	Variable Condenser 2 gang type 2001	97.117	Masonite Back
37.62	Input & Output I.F. Coil	97.157	Grille Cloth
37.88	Broadcast Loop	107.8A	Speaker 6" x 4" Oval Alnico V Magnet
37.108	S.W. and Tropical Antenna Coil	142.37	Knob "Off" Volume (Walnut or Ivory)
37.109	S.W. Oscillator Coil	142.38	Knob Tuning (Walnut or Ivory)
37.110	B.C. and Tropical Oscillator Coil	142.39	Knob B.C.-Tr.-S.W.—Phono (Walnut or Ivory)
42.36	Output Transformer 2500 ohm 400 cycles		

Note: When ordering, please give part number and description.

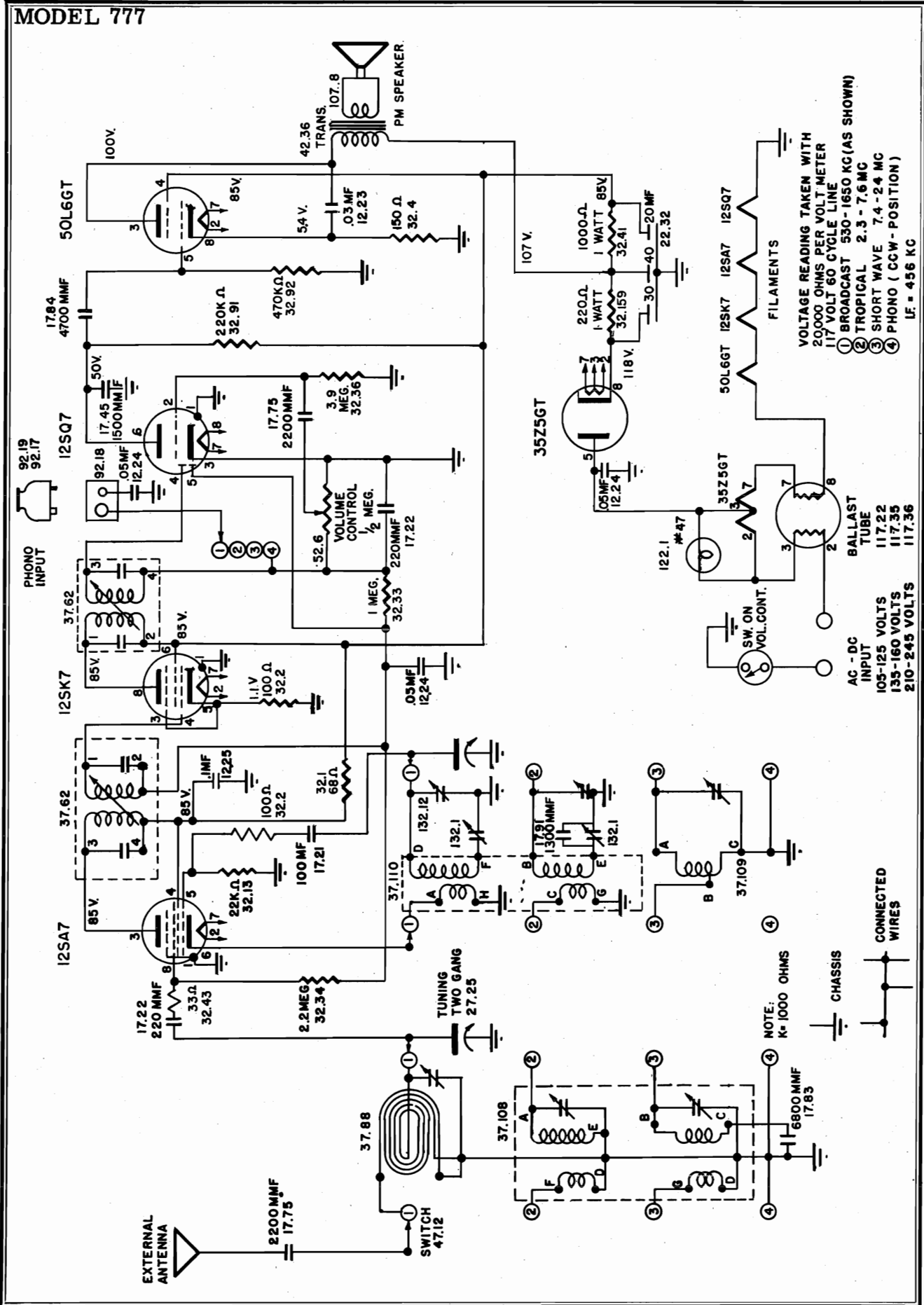

MODELS 4-C-19,
4-C-20, The
Caravan



SPECIFICATIONS

Cabinet Dimensions (Inc. Knobs)	10-3/4" X 4-1/4" X 6-3/8"	Batteries -	One 4-1/2 Volt "A" Firestone 4-D-86
Weight	- 4 Lbs.(Less Batteries)		One 90 Volt "B" Firestone 4-D-88
Power Supply	- 110-120		
	Volt AC-DC & Battery	Tube Complement	
Tuning Range	- 540 to 1600 KC	1R5 - Converter	
Intermediate Freq.	- 455 KC	1U4 - I.F, Amplifier	
Loud Speaker	- 4" PM	1U5 - Diode-Audio Amplifier	
Voice Coil Impedance	- 3.2 Ohms at 400 Cycles	3V4 - Power Output	
Power Output		Rectifier - Selenium Type	
Undistorted	-180 MW		
Maximum	-300 MW		

ALIGNMENT PROCEDURE

For alignment procedure read tabulations from left to right and make the adjustments marked (1) first. (2) next. (3) third.

Before starting alignment:

- (A) Remove the chassis and loop antenna from the cabinet at the same time by removing the battery connectors from the batteries, pulling off knobs and removing the two screws on the chassis tabs which fasten the chassis to the cabinet.
- (B) Use an accurately calibrated test oscillator with some type of output measuring device.

STEP NO.	POSITION OF GANG	SIGNAL GENERATOR FREQUENCY	GENERATOR CONNECTION	DUMMY ANTENNA	ADJUSTMENT	TYPE OF ADJUSTMENT
1	Any point where no interfering signal is received.	Exactly 455 KC	High Side to grid of 1R5 tube. Low side to common negative.	.05 MFD. Condenser	Slug at top of 2nd. I.F. (T2) and then each of the slugs of the 1st. I.F.	For Maximum Output.
2	Exactly 1620 KC.	Exactly 1620 KC.	DUMMY	2 turns of hookup wire 6" in Dia. (Place approximately a foot from, [end of], and in same axis as, loop antenna.)	Front Gang Trimmer.	For Maximum Output.
3	Approximately 1400 KC.	Approximately 1400 KC.			Rear Gang Trimmer.	For Maximum Output.
4	Exactly 600 KC.	Exactly 600 KC.	ANTENNA		Slug in Oscillator Coil (L2).	For Maximum Output.
5					REPEAT STEPS 2 and 3	

MODELS 4-C-19, 4-C-20,
The Caravan

Be sure R.F. and I.F. stages are accurately aligned before measuring gain. R.F. gains can be measured with a "channel" type instrument containing a tuned and calibrated R.F. amplifier. A vacuum tube volt-meter may be used for audio gain measurements. Observe following precautions:

1. For all gain measurements connect signal generator as shown. Use 600 KC. signal with 400 cycle modulation (use nearby frequency if local station interferes.)
2. Be sure radio is carefully tuned to generator signal (use weak signal for sharp tuning.)
3. When using a "channel type instrument carefully tune it for maximum output at desired frequency before making measurements.

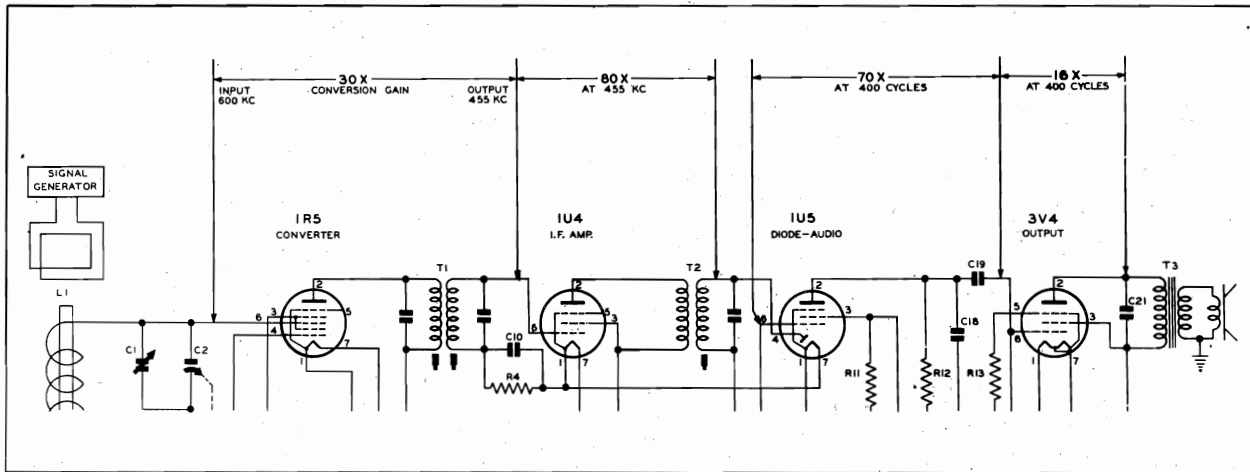

Differences in tube characteristics, tolerance of parts, adjustment of tuned circuits, and variations of line voltage will influence stage gain. Accuracy of measurements is dependent upon careful tuning of receiver to generator signal and experience in using your test equipment. These factors may create considerable variation in gain measurements.

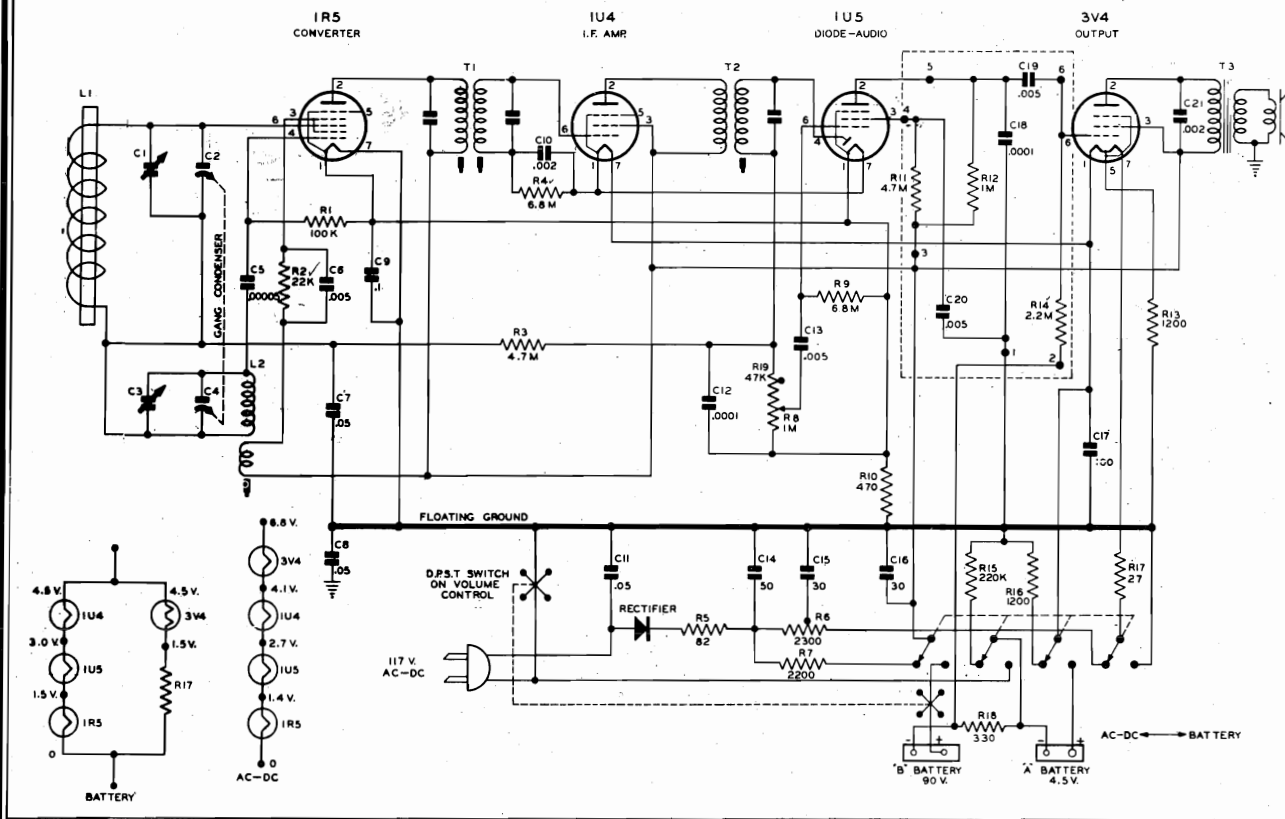

MODELS 4-C-19,
4-C-20, The
Caravan

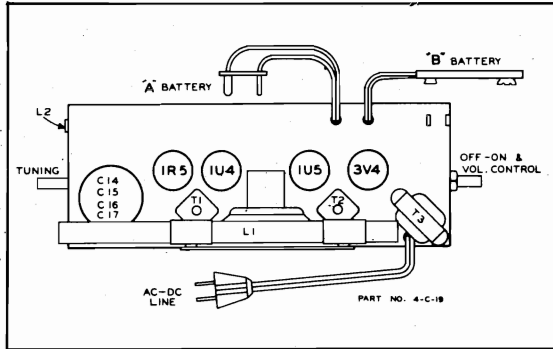

TOP VIEW OF CHASSIS

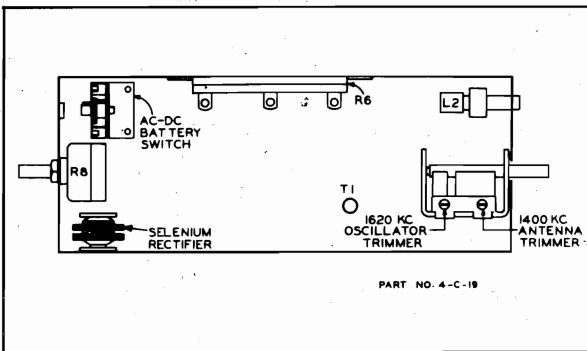

BOTTOM VIEW OF CHASSIS

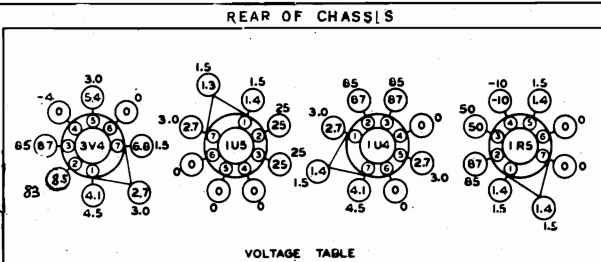

VOLTAGE TABLE
BOTTOM VIEW OF CHASSIS

ALL VOLTAGES EXCEPT FILAMENTS AS INDICATED ARE MEASURED FROM SOCKET CONTACTS TO COMMON NEGATIVE USING A 20000 OHM PER VOLT METER. VOLTAGES IN CIRCLES ARE FOR 117 V. A.C. OPERATION. VOLTAGES NOT IN CIRCLES ARE FOR BATTERY OPERATION.

ILL. NO.	PART NO.	PART NAME	DESCRIPTION	LIST PRICE
R1	N-2973	Resistor Carbon	100,000 Ohm 1/2W. 10%	\$.25
R2	N-6012	Resistor Carbon	22,000 Ohm 1/2W. 10%	.25
R3	N-4061	Resistor Carbon	4.7 Megohm 1/2W. 20%	.25
R4, R9	N-4028	Resistor Carbon	6.8 Megohm 1/2W. 20%	.25

ILL. NO.	PART NO.	PART NAME	DESCRIPTION	LIST PRICE
R5	N-4023	Resistor Carbon	82 Ohm 2.0W. 10%	.30 {Center Tapped
R6	N-8333	Resistor Carbon	2,300 Ohm 5.6W. 5%	
R7	N-4896	Resistor Carbon	2,200 Ohm 1/2W. 10%	.25
R8	N-8332	Volume Control with Switch	- 1.0 Megohm	1.50
R10	N-4066	Resistor Carbon	470 Ohm 1/2W. 10%	.25
R13, R16	N-6793	Resistor Carbon	1,200 Ohm 1/2W. 10%	.25
R15	N-4026	Resistor Carbon	220,000 Ohm 1/2W. 20%	.25
R17	N-6792	Resistor Carbon	27 Ohm 1/2W. 10%	.25
R18	N-4420	Resistor Carbon	330 Ohm 1/2W. 10%	.25
C18)	(.001 MFD.)		
C19, C20)	(.005 MFD.)		
R11	N-8330	Couplate	(4.7 Megohm)	.85
R12)	(1.0 Megohm)		
R14)	(2.2 Megohm)		
C5	N-6375	Condenser Ceramic	50 MMFD. 500V.	.25
C6, C13	N-4894	Condenser Paper	.005 MFD. 600V.	.25
C7, C8	N-1345	Condenser Paper	.05 MFD. 200V.	.25
C9	N-1351	Condenser Paper	.1 MFD. 200V.	.25
C10, C21	N-6377	Condenser Paper	.002 MFD. 600V.	.25
C11	N-1346	Condenser Paper	.05 MFD. 400V.	.25
C12	N-6015	Condenser Ceramic	100 MMFD. 500V.	.25
C14)	(50 MFD. 150V.)		
C15)	(30 MFD. 150V.)		
C16	N-6841	Condenser Electrolytic	(30MFD. 150V.)	3.35
C17)	(100MFD. 25V.)		
	N-8321	Condenser Tuning		2.75
	N-6681	Speaker 4" P.M.		5.05*
L1	N-8328	Coil	Loop Antenna - Iron Rod Type	2.57
T1	N-7981	Transformer	1st. 1.F.	1.60
T2	N-8326	Transformer	2nd. 1.F.	1.60
T3	N-8329	Transformer	Output	1.95
L2	N-8327	Coil	Oscillator	.95
	N-8331	Rectifier	Selenium	1.80
	N-5951	Switch	Power Changeover	1.25
	#335	Cabinet Plastic	Maroon-Less Handle (Stock No.)	\$ 7.05*
	N-8334	Knob Tuning	Maroon (4-C-19)	.40
	N-8345	Knob Volume	Maroon (Only)	.40
	N-8342	Handle	Maroon	.85
	#336	Cabinet Plastic	Green-Less Handle (Stock No.)	\$ 7.05*
	N-8335	Knob Tuning	Green (4-C-20)	.40
	N-8346	Knob Volume	Green (Only)	.40
	N-8410	Handle	Green	.85
	N-8419	Assembly	Grille Cloth & Baffle	.73
	N-8338	Hinge	Cabinet Back	.25
	N-8339	Spring Clip	Cabinet Back Retaining	.25

* INCLUDES EXCISE TAX

ORDERING PARTS

Order parts from your nearest Firestone Tire and Auto Supply Warehouse. When ordering parts, it is important that the correct code number and stock number, be given with the correct part name and part number as shown in the parts list.

**MODEL 4-C-21,
Code 120-1-C51**

OPERATION

POWER SELECTOR SWITCH (See Fig. 2)

This control is located on the back of the radio chassis. Release snap fastener securing door on back of cabinet. Remove line cord from compartment and turn switch to "AC-DC" or "BATT." position. The line cord is stored in this compartment when the radio is operating on batteries.

VOLUME CONTROL KNOB (See Fig. 1)

This knob is located on the left side of the radio. Turning this knob slightly to the right until a slight click is heard will put the radio into operation. Turning this knob further to the right will increase the volume and turning it to the left will decrease the volume. After a station has been selected, the volume control should be adjusted to the desired level. The volume should never be reduced by detuning the station selector knob.

STATION SELECTOR KNOB (See Fig. 1)

This knob is located on the right side of the radio. Turn the knob until a desired station has been selected. Adjust very carefully until the station comes in with the most natural tone.



Fig. 1

DESCRIPTION

This Portable Receiver is a 5-tube plus rectifier superhetrodyne, designed to operate on 115 to 125 volts, AC-DC power, or on self-contained batteries. The receiver covers the frequency range 538 to 1620 KC. Three controls are provided for operating the receiver. See Fig. 1 and 2.

This receiver is equipped with a tuned R.F. Stage, a 3-gang tuning condenser and the newly designed "Magna-Loop" antenna, thereby insuring the finest in sensitivity and selectivity. It is designed with the patented "Battery Rejuvenator". Proper use of this rejuvenator will extend the normal life of the "B" batteries 2 to 4 times for extra hours of listening pleasure.

ELECTRICAL SPECIFICATIONS

Power supply.....	115 to 125 volts AC-DC	This receiver contains the following:
	or 2 45 volt "B" batteries	1-1T4 or 1U4RF Amplifier
	and 2 4½ volt "A" batteries	1-1R5Converter
Frequency Range	538 - 1620 KC.	1-1T4 or 1U4I. F. Amplifier
Speaker	5" PM	1-1U5Detector-AVC-1st Audio
Power Output25 watts maximum	1-3V4Power Output

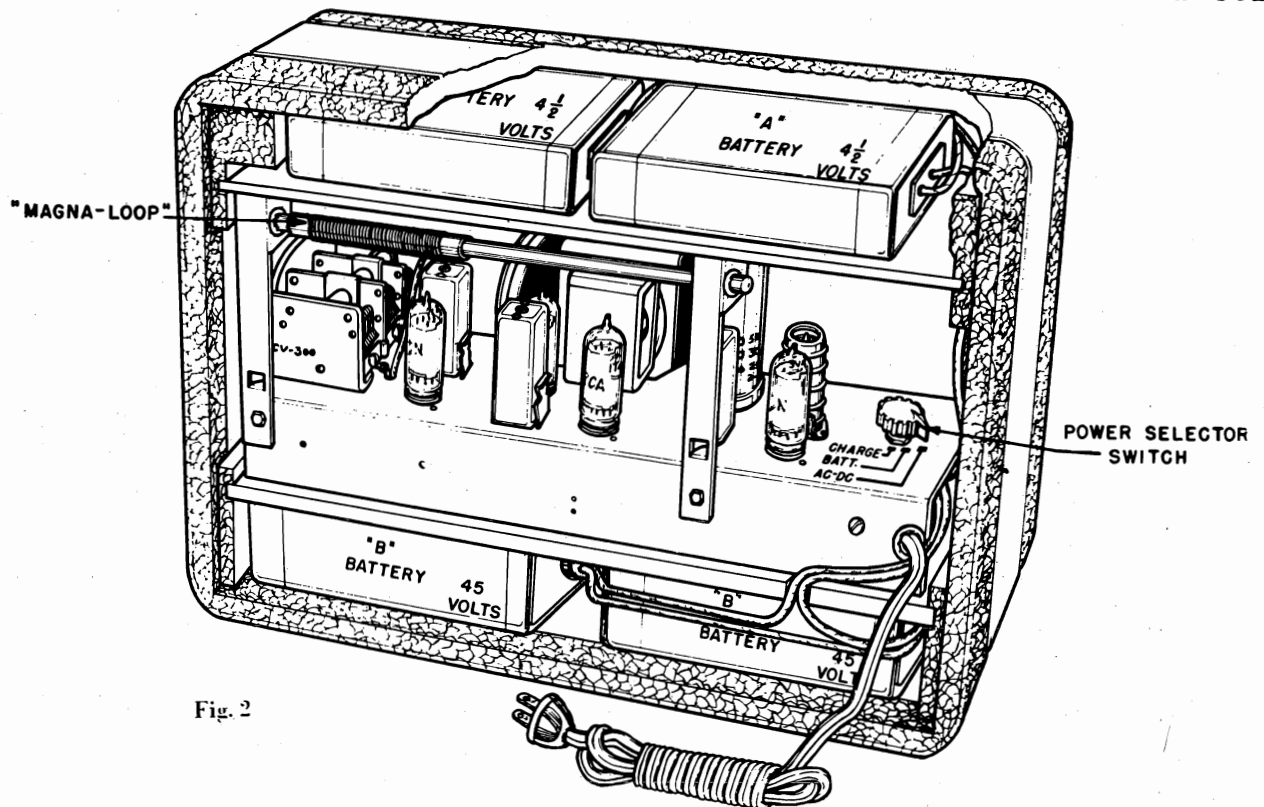

Fig. 2

BATTERY INSTALLATION

BATTERY INSTALLATION

Batteries Required

- 2 4½ volt "A" Batteries Firestone No. 4-D-36
- 2 45 volt "B" Batteries Firestone No. 4-D-89

1. Remove two wood screws located in upper corners of back.
2. Swing top of back away from cabinet and remove by lifting in an upward direction.
3. Install batteries and insert cable plugs as shown in Fig. 2.

BATTERY CHARGING

The "B" batteries can be recharged in the following manner:

1. Turn power selector switch to charge position.
2. Plug line cord into an AC or DC 115-125 volt power line.
3. Turn volume control on.

The best possible performance on battery operation can be realized if the batteries are periodically charged by the Rejuvenator for as long a period as they have been in use, rather than waiting until they run down. For example, if the receiver has been operated on battery power for four hours, it should be on charge for at least four hours afterwards. In this manner, the quality and sensitivity of the receiver will be at a maximum since the fully charged batteries will insure "new battery" performance.

CAUTION: Do not attempt to remove tubes or replace batteries while receiver is turned on.

MODEL 4-C-21,
Code 120-1-C51

ALIGNING INSTRUCTIONS

Never attempt any adjustments on this receiver unless it becomes necessary to replace a coil or transformer, or the adjustments have been tampered with in the field. Always make certain that other components such as tubes, condensers, resistors, etc., are normal before proceeding with realignment. If realignment is necessary, follow the instructions given under the heading "Alignment Procedure". After realignment has been completed, repeat the procedure as a final check.

To remove the radio chassis for servicing, remove the back cover and disconnect cables from batteries. Remove batteries and pull out the top shelf. Slide out the chassis and bottom shelf and remove the screws securing chassis to shelf.

ALIGNMENT PROCEDURE

- Volume control — Maximum, all adjustments.
- No signal applied to antenna.
- Power input — 115 to 125 Volts AC or DC.
- Connect dummy antenna in series with output lead of signal generator.
- Connect ground lead of signal generator to chassis.
- Repeat alignment procedure as a final check.

- The following equipment is necessary for proper alignment:
- Signal generator that will provide the test frequencies as listed, modulated 400 cycles, 30%.
- Non-metallic screwdriver.
- Output meter. (1.8 volt for 1 watt output).
- Dummy antenna — .1 MFD.
- For alignment points refer to Schematic Diagram.

Dial Setting	Generator Frequency	Dummy Ant.	Generator Connection	Trimmer Reference	Trimmer Adjustment	Trimmer Function
1. Fully open	455 KC	.1 MFD	1R5 Grid	T2 Top & bottom	Maximum	Output I.F.
2. Fully open	455 KC	.1 MFD	1R5 Grid	T1 Top & bottom	Maximum	Input I.F.
3. Fully open	1620 KC	.1 MFD	Grid 1T4 RF Stage	CV2	Maximum	Oscillator
4. Tune in signal from generator	1400 KC	.1 MFD	Grid 1T4 RF Stage	CV3	Maximum	RF Stage
5. Tune in signal from generator	600 KC	.1 MFD	Grid 1T4 RF Stage	L2	Maximum	RF Stage
6. Tune in signal from generator	1400 KC		Loosely couple signal generator leads to "Magna Loop"	CV1	Maximum	Antenna

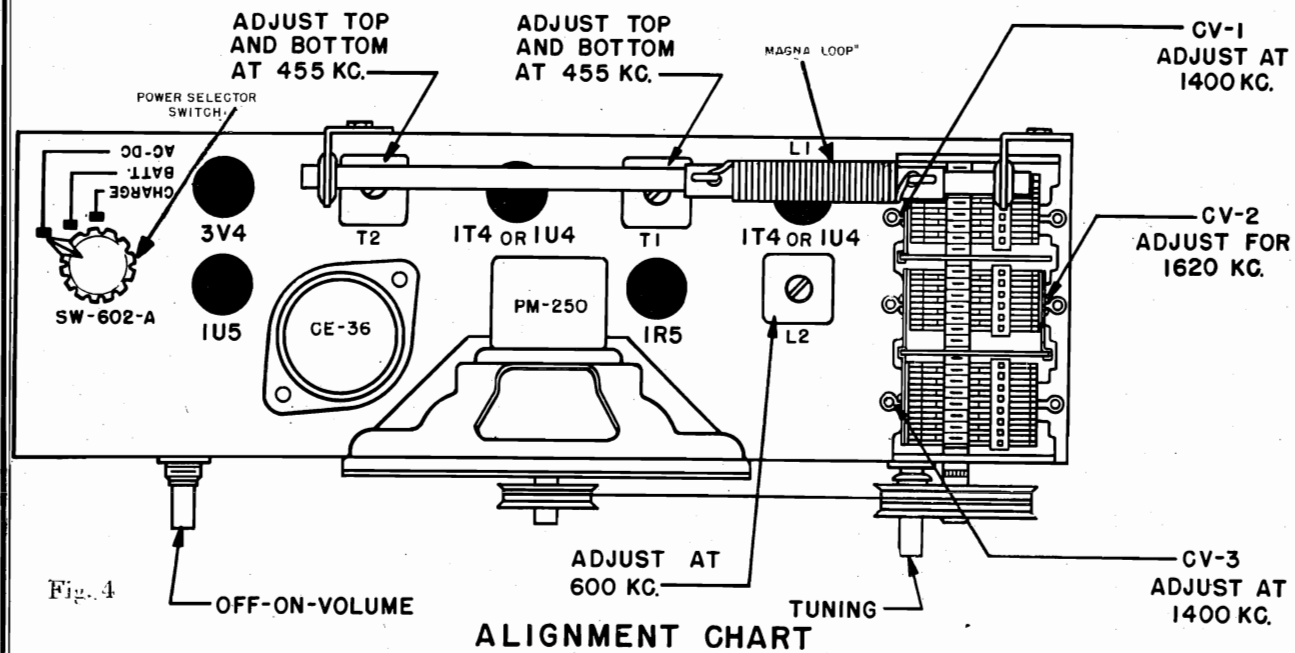

MODEL 4-C-21,
Code 120-1-C51

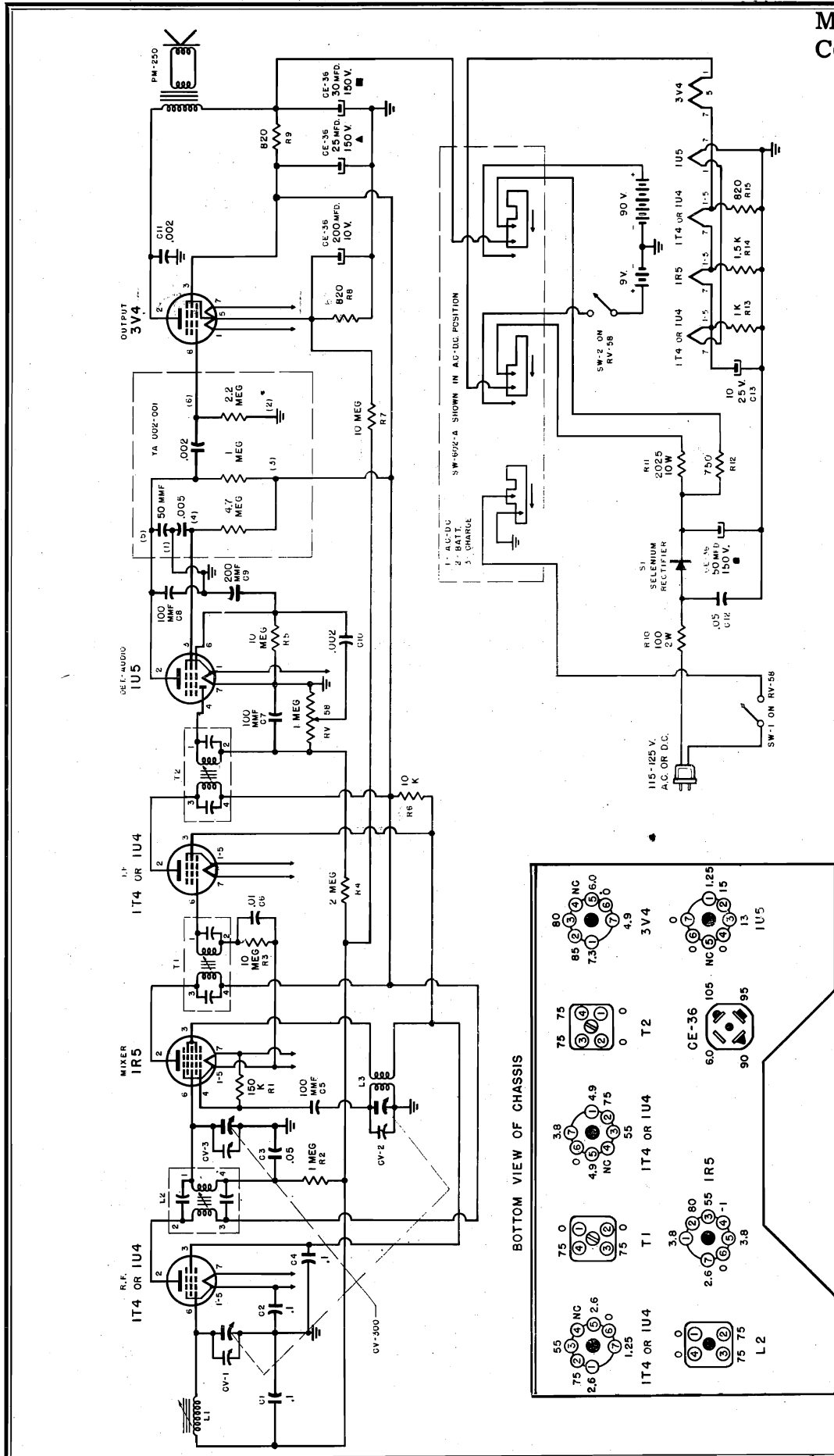

Fig. 3
FRONT OF CHASSIS
VOLTAGE CHART

Voltage taken from different points of the circuit to the chassis are measured with volume control in maximum position, all tubes in their sockets, no signal applied, and with a voltmeter having a resistance of 20,000 ohms per volt. These voltages are shown on the voltage chart Fig. 3. All voltages should be measured with an input voltage of 118 volts AC or DC. To check for open bypass condensers, shunt each condenser with another one having the same capacity and voltage rating which is known to be good until the defective unit is located.

MODEL 4-C-21,
Code 120-1-C51

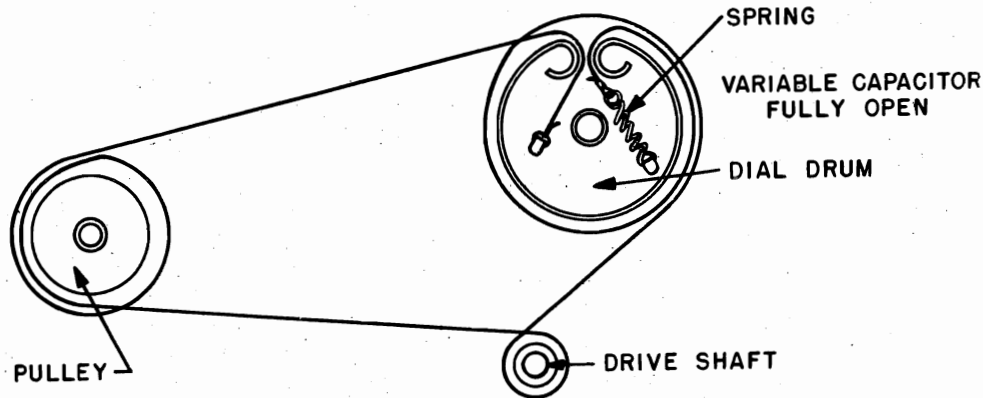

Fig. 5

PARTS AND PRICE LIST

CONDENSERS

Schematic Diagram Reference	Part No.	Description	List Price
C1, C2, C4	C208	.1 MFD 400 Volt Condenser	\$.35
C3	C207	.05 MFD 200 Volt Condenser	.25
C5, C7, C8	CC200	100 MMFD Ceramic Condenser	.25
C6	C206	.01 MFD 400 Volt Condenser	.30
C9	CC201	200 MMD Ceramic Condenser	.25
C10, C11	C203	.002 MFD 400 Volt Condenser	.25
C12	C204	.05 MFD 400 Volt Condenser	.35
C13	C205	10 MFD 25 Volt Condenser	.50
CE-36	CE-36	50 MFD 150 Volt Electrolytic Condenser 30 MFD 150 Volt Electrolytic Condenser 25 MFD 150 Volt Electrolytic Condenser 200 MFD 10 Volt Electrolytic Condenser	2.65
CV1, CV2, CV3	CV-300	3 Section Variable Condenser	3.65

RESISTORS

R1	R315	150 K ohm 1/2 watt 20% resistor	.10
R2	R309	1 meg ohm 1/2 watt 20% resistor	.10
R3, R5, R7	R311	10 meg ohm 1/2 watt 20% resistor	.10
R4	R310	2 meg ohm 1/2 watt 20% resistor	.10
R6	R316	10 K ohm 1/2 watt 20% resistor	.10
R8, R9, R15	R317	820 ohm 1/2 watt 20% resistor	.10
R10	R318	100 ohm 2 watt 10% resistor	.25
R11	R319	2025 ohm 10 watt 20% resistor	.50
R12	R320	750 ohm 1/2 watt 20% resistor	.10
R13	R321	1 K ohm 1/2 watt 20% resistor	.10
R14	R314	1.5 K ohm 1/2 watt 20% resistor	.10

COILS AND TRANSFORMERS

L1	L-A51	Magna Loop Antenna Coil	1.50
L2	57FB-4	R. F. Coil	2.00
L3	L-051	R.F. Oscillator Coil	1.00
T1	1655-16	1st I.F. Transformer	2.00
T2	1655-16	2nd I.F. Transformer	2.00

MISCELLANEOUS

SW-602A	Power Selector Switch	\$1.00
PM-250	Speaker 5" PM (Includes output transformer)	5.75
S1	Selenium Rectifier	1.50
H208	Clip Coil Mounting	.05
H51	Knob	.10
B51	"A" Battery Cable	.75
B52	"B" Battery Cable	.75
H53	Cabinet less back	5.95
H54	Cabinet back	1.50
4-D-89	"B" Battery, 45 volt	2.25
4-D-86	"A" Battery, 4 1/2 volt	.85

DIAL PARTS

H55	Plastic Dial	\$2.00
H56	Dial Pointer	.25
H57	Dial Pulley	.05
H58	Spring, Dial Drive String Tension	.05
H59	String, Dial Drive	.10

Prices subject to change without notice

MODELS 4-A-101,
4-A-102, Code
297-2-3419

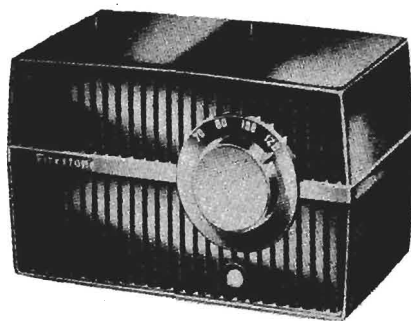

SPECIFICATIONS

CABINET DIMENSIONS

Length 8-9/16"
Depth 5"
Height 5"

LOUD SPEAKER 4 Inch PM

VOICE COIL IMPEDANCE 3.2 Ohm at
400 Cycles

POWER OUTPUT Undistorted - 0.9 Watt
Maximum - 1.8 Watts

SHIPPING WEIGHT 4-1/4 Lbs.

POWER SUPPLY 110 to 120 Volt AC-DC

TUNING RANGE 540 to 1600 KC

INTERMEDIATE FREQUENCY 455KC

TUBE COMPLEMENT

12AU6 - Converter
12AV6 - Diode Audio
50C5 - Output
35Z5GT - Rectifier

ALIGNMENT PROCEDURE

For alignment procedure read tabulations from left to right, and make the adjustments marked (1) first, (2) next, (3) Third.

Before starting alignment

- (A) Remove chassis and loop from cabinet. Leave loop in position on its mounting bracket. Turn tuning capacitor until plates are completely in mesh and replace tuning knob with indicator pointing to the left and parallel to chassis base.
- (B) Use an accurately calibrated test oscillator with some type of output measuring device.
- (C) When aligning the 1400 KC Antenna Trimmer and the 1620 KC Oscillator Trimmer, couple test oscillator to receiver loop by; (1) make loop consisting of two turns of #22 size wire wound on a form of 6" in dia. (2) connect this loop across output of test oscillator; (3) place test oscillator loop approximately a foot from and in the same plane as the receiver loop.
BE SURE THAT NEITHER LOOP MOVES WHILE ALIGNING.

Steps	Set Receiver dial to:	TEST OSCILLATOR		Refer to parts layout diagram for location of trimmers mentioned below:
		Adjust test oscillator frequency to:	Attach output of test oscillator to:	
1	ANY POINT WHERE NO INTERFERING SIGNAL IS RECEIVED. WITH TUNING CONDENSER NEAR CENTER	455 K.C.	HIGH SIDE TO REAR STATOR PLATES OF TUNING CONDENSER. LOW SIDE TO COMMON NEGATIVE THROUGH A .05 MFD BLOCKING CONDENSER	ADJUST SLUGS AT TOP AND BOTTOM OF I.F. CAN FOR MAXIMUM OUTPUT.
2	EXACTLY 1620 K.C.	EXACTLY 1620 K.C.	SEE PARAGRAPH "C" ABOVE	ADJUST 1620 K.C. OSCILLATOR TRIMMER FOR MAXIMUM OUTPUT.
3	APPROX. 1400 K.C.	APPROX. 1400 K.C.	SEE PARAGRAPH "C" ABOVE	ADJUST 1400 K.C. ANTENNA TRIMMER FOR MAXIMUM OUTPUT.

**MODELS 4-A-101,
4-A-102, Code 297-2-3419**

Be sure R.F. and I.F. stages are accurately aligned before measuring gain. R.F. gains can be measured with a "channel" type instrument containing a tuned and calibrated R.F. amplifier. A vacuum tube volt-meter may be used for audio gain measurements. Observe following precautions:

1. For all gain measurements connect signal generator as shown. Use 600 KC. signal with 400 cycle modulation (use nearby frequency if local station interferes.)
2. Be sure radio is carefully tuned to generator signal (use weak signal for sharp tuning.)
3. When using a "channel type instrument carefully tune it for maximum output at desired frequency before making measurements.

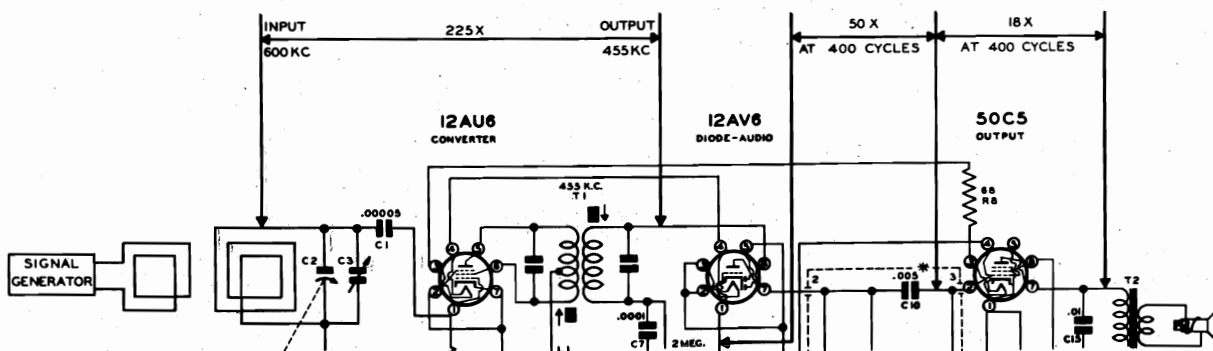

Differences in tube characteristics, tolerance of parts, adjustment of tuned circuits, and variations of line voltage will influence stage gain. Accuracy of measurements is dependent upon careful tuning of receiver to generator signal and experience in using your test equipment. These factors may create considerable variation in gain measurements.

ORDERING PARTS

Order parts from your nearest Firestone Tire and Auto Supply Warehouse. When ordering parts, it is important that the correct code number and stock number, be given with the correct part name and part number as shown in the parts list.

PARTS LIST

ILLUS. NO.	PART NO.	PART NAME	DESCRIPTION	LIST PRICE	ILLUS. NO.	PART NO.	PART NAME	DESCRIPTION	LIST PRICE
C1	N-6385	Condenser	Ceramic 50 MMFD. 500 Volts 10%	\$.25	R6	N-4067	Resistor	Carbon 180 Ohm 1/2 Watt 10%	\$.25
C2,C5	N-8508	Condenser	Gang Tuning	2.55	R7	N-4896	Resistor	Carbon 2,200 Ohm 1/2 Watt 10%	.25
C4	N-1345	Condenser	Paper .05 MFD. 200 Volts	.25	R8	N-6014	Resistor	Carbon 68 Ohm 2.0 Watt 10%	.30
C7	N-6015	Condenser	Ceramic 100 MMFD. 500 Volts 20%	.25	R9	N-4022	Resistor	Carbon 33 Ohm 1/2 Watt 20%	.25
C8	N-2063	Condenser	Paper .003 MFD. 600 Volts	.25	T1	N-7694	Transformer	I. F.	1.65
*C9	N-6488	Condenser	Ceramic 250 MMFD. 500 Volts 20%	.25	L1	N-8552	Coil	Oscillator	.80
*C10	N-4894	Condenser	Paper .005 MFD. 600 Volts	.25		N-8581	Coil	Loop Antenna and Cabinet Back	1.50
C11)			(20 MFD. 15 Volts)			N-7824	Speaker	4 "PM with Output Transformer	6.78**
C12)	N-8442	Condenser	Electrolytic (20 MFD. 150 Volts)	1.70	#341	Cabinet	Plastic - White ()	5.05**	
C13)			(40 MFD. 150 Volts)		#356	Cabinet	Plastic - Red ()	5.05**	
C14	N-1346	Condenser	Paper .05 MFD. 400 Volts	.25	#357	Cabinet	Plastic - Green (Stock No.)	5.05**	
C15	N-1344	Condenser	Paper .01 MFD. 400 Volts	.25	N-8422	Knob	Volume Control - White (4-A-102)	.25	
R1	N-4277	Resistor	Carbon 2.2 Megohm 1/2 Watt 20%	.25	N-8619	Knob	Volume Control - Red (Only)	.25	
R2	N-7142	Resistor	Volume Control with Switch	1.10	N-8620	Knob	Volume Control - Green ()	.25	
R3	N-4028	Resistor	Carbon 6.8 Megohm 1/2 Watt 20%	.25	N-8604	Knob	Station Tuning - White ()	.60	
R4	N-4026	Resistor	Carbon 220,000 Ohm 1/2 Watt 20%	.25	#349	Cabinet	Plastic - Walnut (Stock No.)	3.53**	
R5	N-4027	Resistor	Carbon 470,000 Ohm 1/2 Watt 20%	.25	N-8421	Knob	Volume Control - Walnut (4-A-101)	.25	
					N-8364	Knob	Station Tuning - Walnut (Only)	.60	

NOTES - * In some receivers, the following components (C9,C10,R4 and R5) are replaced by the assembly listed below

- N-8215 Assembly Audio Coupling Plate
- ** Excise Tax included.

MODELS 4-A-101,
4-A-102, Code
50C5 297-2-3419
OUTPUT

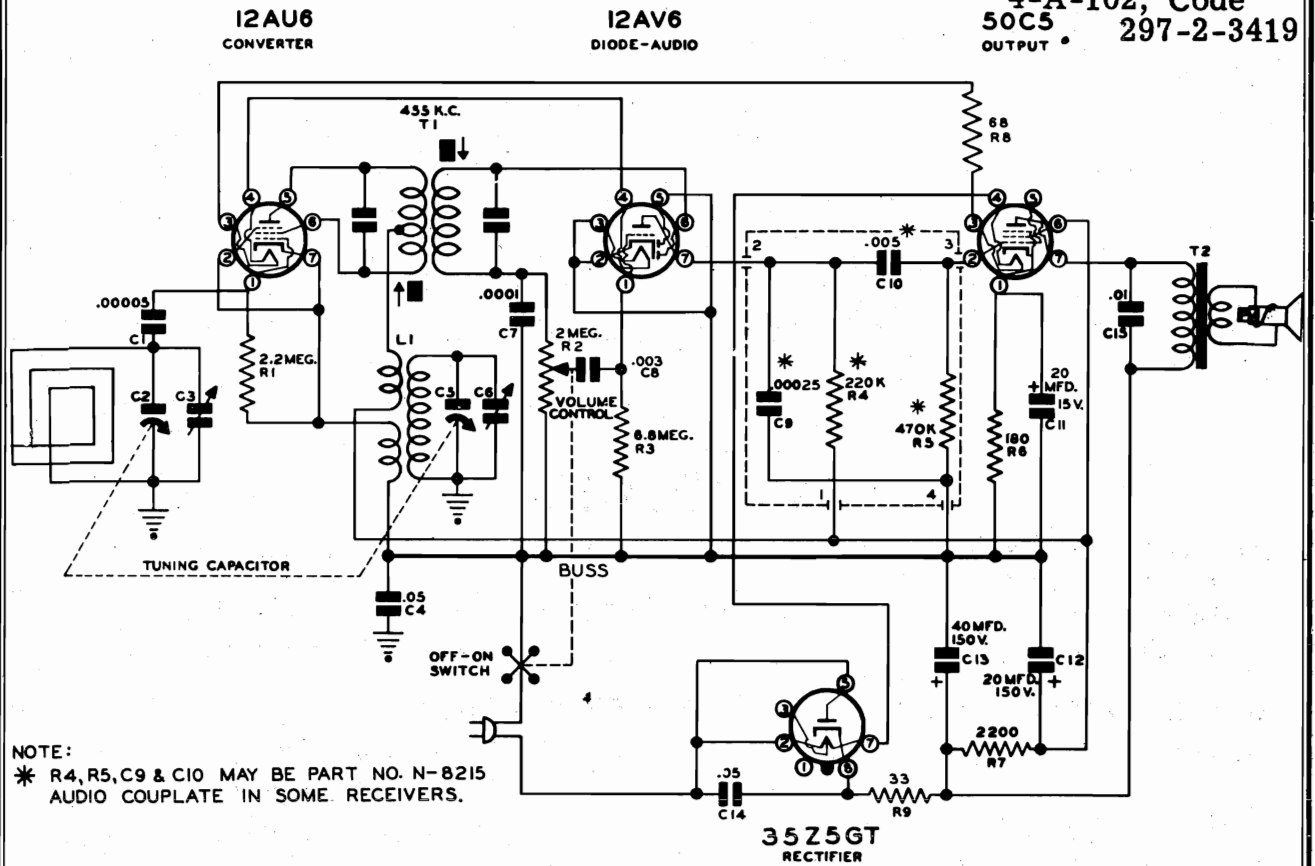

NOTE:
* R4, R5, C9 & C10 MAY BE PART NO. N-8215
AUDIO COUPLATE IN SOME RECEIVERS.

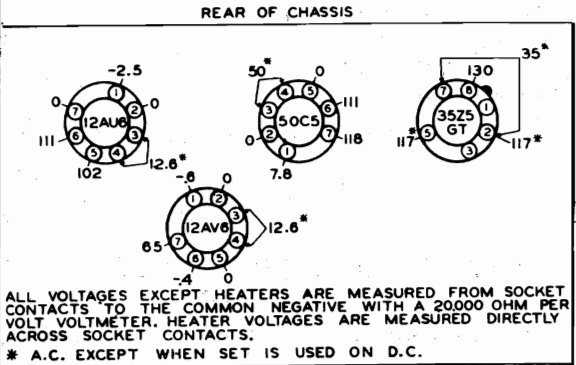

VOLTAGE TABLE
(BOTTOM VIEW OF CHASSIS)

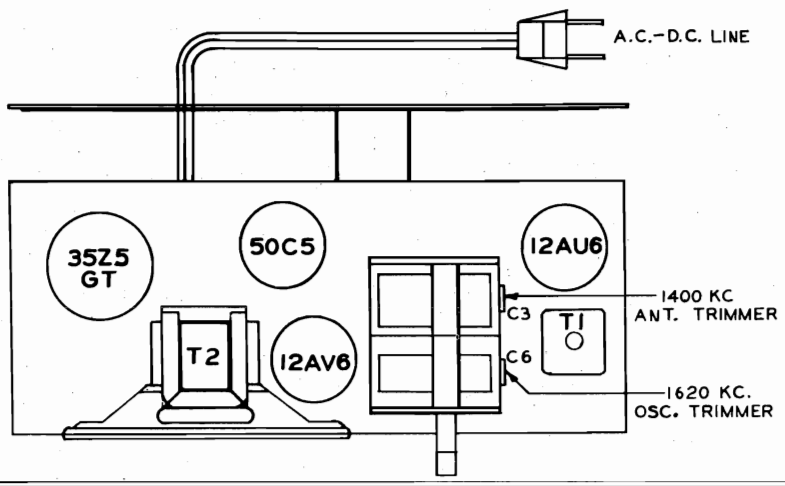
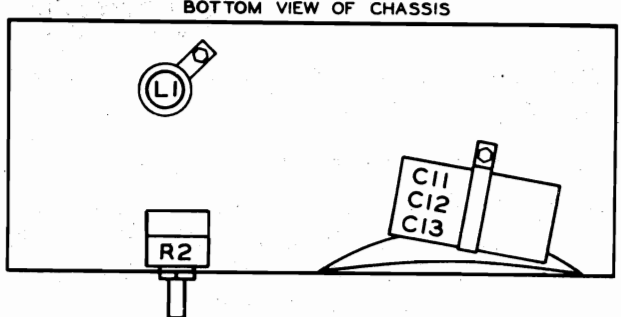

MODEL 4-A-108

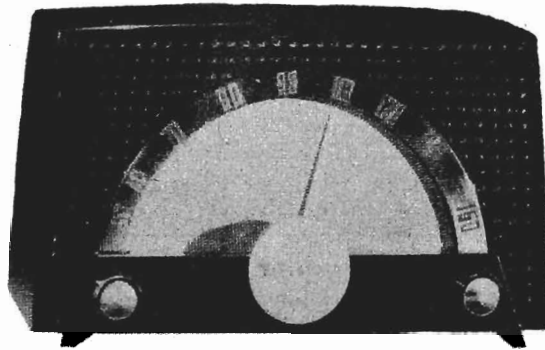

SPECIFICATIONS

CABINET DIMENSIONS -

Length 10-5/16"
 Depth 5-3/4"
 Height 6-3/16"

VOICE COIL IMPEDANCE - 3.2 Ohms at 400 cycles

POWER OUTPUT Undistorted - 0.8 Watts
 Maximum - 1.3 Watts

SHIPPING WEIGHT - 6 1/2 lbs.

TUBE COMPLEMENT -

POWER SUPPLY - 110 to 120 Volts
 AC-DC

12SA7 - Converter
 12SK7 - I. F. Amplifier
 12SQ7 - Diode-Audio
 50L6GT - Output
 35Z5GT - Rectifier

TUNING RANGE - 540 to 1600 KC

INTERMEDIATE FREQ. - 455 KC

LOUD SPEAKER - 4 Inch PM

ALIGNMENT PROCEDURE

For alignment procedure read tabulations from left to right, make the adjustments marked (1) first, (2) next, (3) third.

BEFORE STARTING ALIGNMENT:

- (A) Remove loop and chassis from cabinet. (CAUTION: DIAL ESCUTCHEON TAB ABOVE GANG CONDENSER ON INSIDE OF CABINET MUST BE STRAIGHTENED BEFORE REMOVING CHASSIS.) Loop must be mounted to its normal position on chassis for alignment.
- (B) Use an accurately calibrated test oscillator with some type of output measuring device.

STEP NO.	SIGNAL GENERATOR FREQUENCY	GENERATOR CONNECTION	POSITION OF GANG	DUMMY ANTENNA	ADJUSTMENT	TYPE OF ADJUSTMENT
1	Exactly 455 KC	High Side to grid of 12SA7 tube. Low side to common negative.	Any point where no interfering signal is received.	.05 MFD. Condenser	Slug at top of 2nd. I.F. (T2) and then each of the slugs of the 1st. I.F.	For Maximum Output
2	Exactly 1620 KC	DUMMY	Rotor fully open.	2 turns of hookup wire 6" in Dia. (Place approximately a foot from end of, and in same axis as, loop antenna)	Front Gang Trimmer	For Maximum Output
3	Approximately 1400 KC.	ANTENNA	Tune in signal from generator.		Rear Gang Trimmer	For Maximum Output

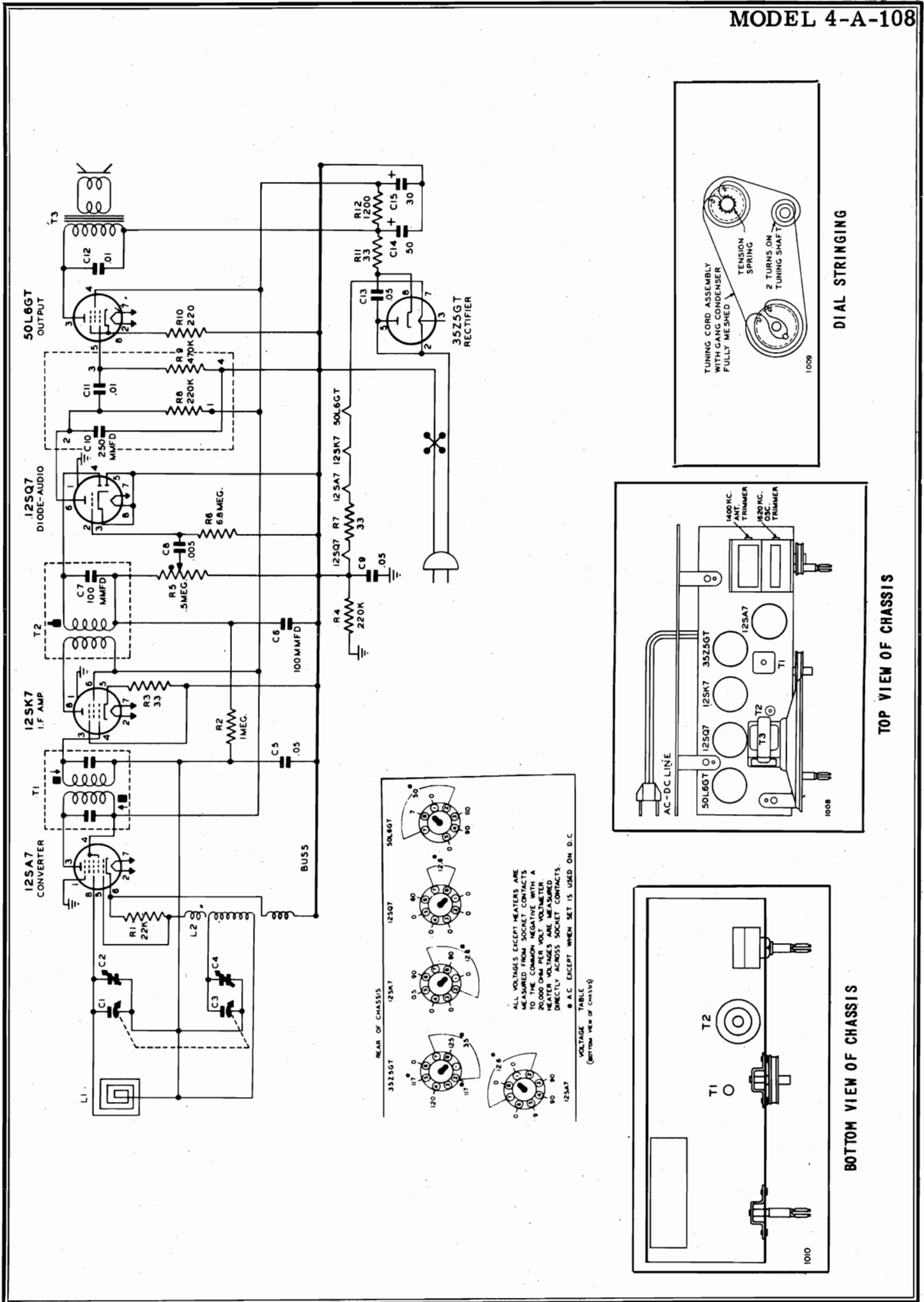

MODEL 4-A-108

Be sure R.F. and I.F. stages are accurately aligned before measuring gain. R.F. gains can be measured with a "channel" type instrument containing a tuned and calibrated R.F. amplifier. A vacuum tube voltmeter may be used for audio gain measurements. Observe following precautions:

1. For all gain measurements connect signal generator as shown. Use 600 KC. signal with 400 cycle modulation (use nearby frequency if local station interferes.)
2. Be sure radio is carefully tuned to generator signal (use weak signal for sharp tuning.)
3. When using a "channel type instrument carefully tune it for maximum output at desired frequency before making measurements.

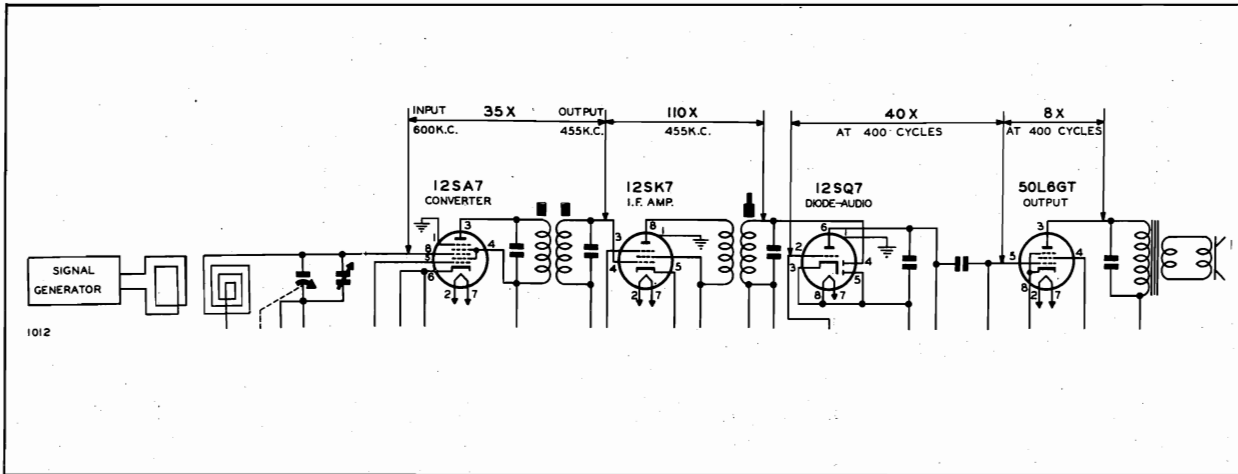

Differences in tube characteristics, tolerance of parts, adjustment of tuned circuits, and variations of line voltage will influence stage gain. Accuracy of measurements is dependent upon careful tuning of receiver to generator signal and experience in using your test equipment. These factors may create considerable variation in gain measurements.

PARTS LIST

ILLUS. NO.	PART NO.	PART NAME	DESCRIPTION	LIST PRICE	ILLUS. NO.	PART NO.	PART NAME	DESCRIPTION	LIST PRICE
C1,C3	N-8745	Condenser	Gang Tuning with Pulley	\$3.00	R5	N-8732	Volume Control	With Switch - 500,000 Ohms	\$ 1.15
C2,C4	---	Trimmers	Gang		R6	N-4028	Resistor	Carbon 6.8 Megohm 1/2 W. 20%	.25
C5,C9	N-1345	Condenser	Paper .05 MFD. 200 Volts	.25	R7	N-4068	Resistor	Carbon 33 Ohm 1.0 Watt 20%	.25
C6	N-6015	Condenser	Ceramic 100 MMFD. 500 V. 20%	.25	*R8	N-4026	Resistor	Carbon 220,000 Ohm 1/2 W. 20%	.25
C7	PART OF 2nd I.F. Trans. N-8150				*R9	N-4027	Resistor	Carbon 470,000 Ohm 1/2 W. 20%	.25
		Condenser	100 MMFD. 500 Volt 10%		R10	N-4024	Resistor	Carbon 220 Ohm 1/2 Watt 10%	.25
C8	N-4894	Condenser	Paper .005 MFD. 600 Volts	.25	T1	N-7981	Transformer	1st I. F.	1.50
*C10	N-6488	Condenser	Ceramic 250 MMFD. 500 V. 20%	.25	T2	N-8150	Transformer	2nd I. F.	1.10
*C11	N-1344	Condenser	Paper .01 MFD. 400 Volts	.25		N-7824	Speaker	4" PM With Transformer	6.65**
C12	N-1344	Condenser	Paper .01 MFD. 400 Volts	.25	L1	N-8740	Coil	Loop Antenna h& Cabinet Back	1.80
C13	N-1346	Condenser	Paper .05 MFD. 400 Volts	.25	L2	N-8709	Coil	Oscillator	.90
C14)	N-7889	Condenser	Electrolytic(50 MFD. 150 V.)	1.95		#361	Cabinet	Plastic	6.40**
C15)			(30 MFD. 150 V.)						
R1	N-4025	Resistor	Carbon 22,000 Ohm 1/2W. 20%	.25		N-8733	Knobs	Plastic	.25
R2	N-1262	Resistor	Carbon 1.0 Megohm 1/2W. 20%	.25		N-8735	Escutcheon	Dial	.98
R3,R11	N-4022	Resistor	Carbon 33 Ohm 1/2 Watt 20%	.25		N-8737	Pointer	Dial	.43
R4	N-4026	Resistor	Carbon 220,000 Ohm 1/2 W. 20%	.25		N-8883	Assembly	Baffle & Cloth	1.75

NOTES: *In some receivers, the components C10,C11,R8 and R9 are replaced by the assembly listed below:

N-8215 Assembly, Audio Coupling Plate .53

**Excise Tax Included.

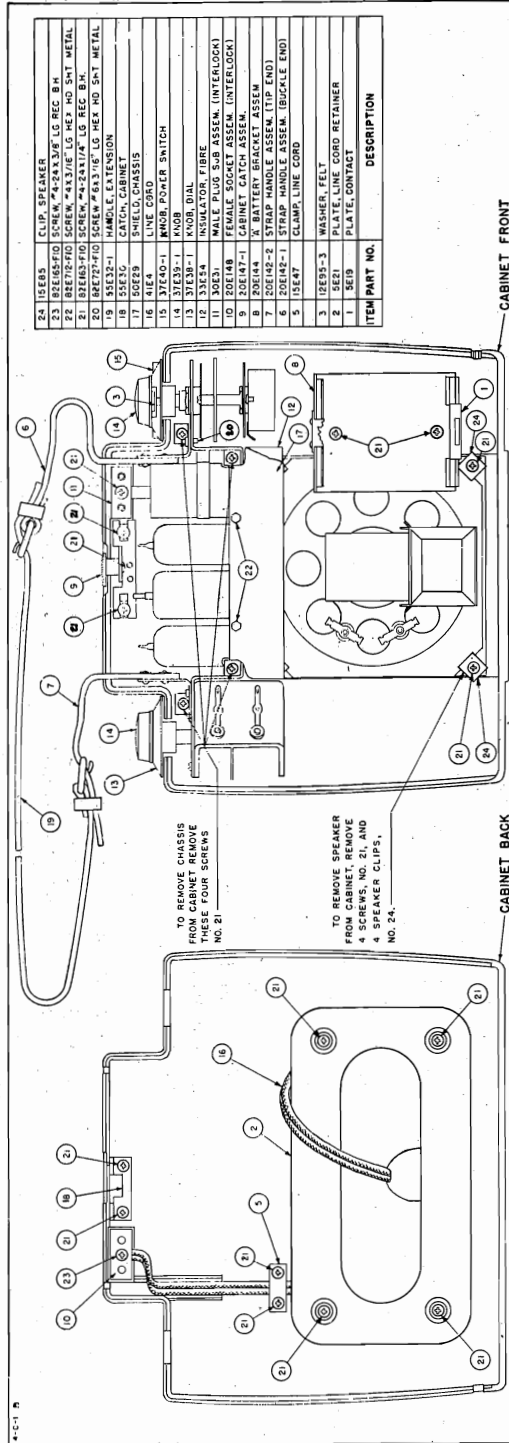
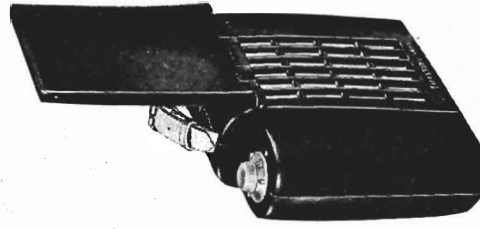

ITEM PART NO.	DESCRIPTION
24	15628A CLIP, SPEAKER
23	B2E165-FD SCREW #4-24X3/8 LG REC B.H.
22	B2E172-FD SCREW #4-3/16 LG HEZ HD SMT METAL
21	B2E165-FD SCREW #4-24X1/4 LG REC B.H.
20	B2E172-FD SCREW #4-3/16 LG HEZ HD SMT METAL
19	15512-1 SHIELD, CHASSIS
18	15512-2 SHIELD, CHASSIS
17	15522-9 SHIELD, CHASSIS
16	4164 LINE CORD
15	37640-1 MOTOR, POWER SWITCH
14	37639-1 MOTOR, PAUL
13	37638-1 MOTOR, PAUL
12	37637-1 MOTOR, PAUL
11	30624 MALE PLUG SUB ASSEM. (INTERLOCK)
10	20E148 FEMALE SOCKET ASSEM. (INTERLOCK)
9	20E147-1 CABINET CATCH ASSEM.
8	20E144 X BATTERY BRACKET ASSEM.
7	20E143 X BATTERY BRACKET ASSEM.
6	20E142-1 STRAP HANDLE ASSEM. (BAGGLE END)
5	151647 CLAMP, LINE CORD
3	12E95-3 WASHER, FELT
2	5E21 PLATE, LINE CORD RETAINER
1	5E19 PLATE, CONTACT

ALIGNMENT PROCEDURE

Be sure to follow procedure carefully and in the order given—otherwise the receiver will be insensitive and the dial calibration incorrect. For alignment procedure read tabulations from left to right. Make the adjustment marked (1) first, (2) next, (3) third.

Before starting alignment:

- (a) Check tuning dial adjustment by tuning gang condenser until plates touch maximum capacity stop (completely in mesh) at which point the dial indicator must be exactly even with the center of the large 5 in the 55 calibration number at the low frequency end of the dial scale. If dial indicator does not point exactly to the center of the large 5, move to correct position.
- (b) Use an accurately calibrated test oscillator with some type of output measuring device.
- (c) WHEN ADJUSTING 1620 KC OSCILLATOR TRIMMER, remove chassis from cabinet and disconnect the loop connection wires from the loop. Attach a 1 megohm resistor across these connections and feed output of test oscillator across the 1 megohm resistor.
- (d) THE 1400 KC LOOP ANTENNA TRIMMER should be adjusted only after all other adjustments have been made and with the set mounted in the cabinet, and the loop in an upright position. When aligning the 1400 KC Antenna Trimmer, couple test oscillator to receiver loop by: (1) make loop consisting of five to ten turns of No. 20 to No. 30 size wire, wound on a 2" or 3" form; (2) connect this loop across output of test oscillator; (3) place test oscillator loop near radio loop. BE SURE THAT NEITHER LOOP MOVES WHILE ALIGNING.

MODEL 4-C-1,
Code 291-7-564

TEST OSCILLATOR			
Steps	Set receiver dial to:	Adjust test oscillator frequency to:	Use dummy antenna in series with output of test oscillator consisting of:
1	Any point where no interfering signal is received	Exactly 455 K. C.	0.2 Mfd. Condenser
2	Rotate gang condenser to minimum capacity	Exactly 1620 K. C.	See paragraph (c) above
3	Rotate gang condenser to 1400 K.C.	Exactly 1400 K. C.	See paragraph (d) above

Refer to parts layout diagram for location of trimmers mentioned below:

Adjust each of the 2nd I.F. transformer trimmer adjustment screws for maximum output, then adjust each of the 1st I.F. transformer trimmer adjustment screws for maximum output.

Adjust 1620 Osc. Trimmer for maximum 1620 K.C. signal.

Adjust 1400 K.C. Ant. Trimmer for maximum output.

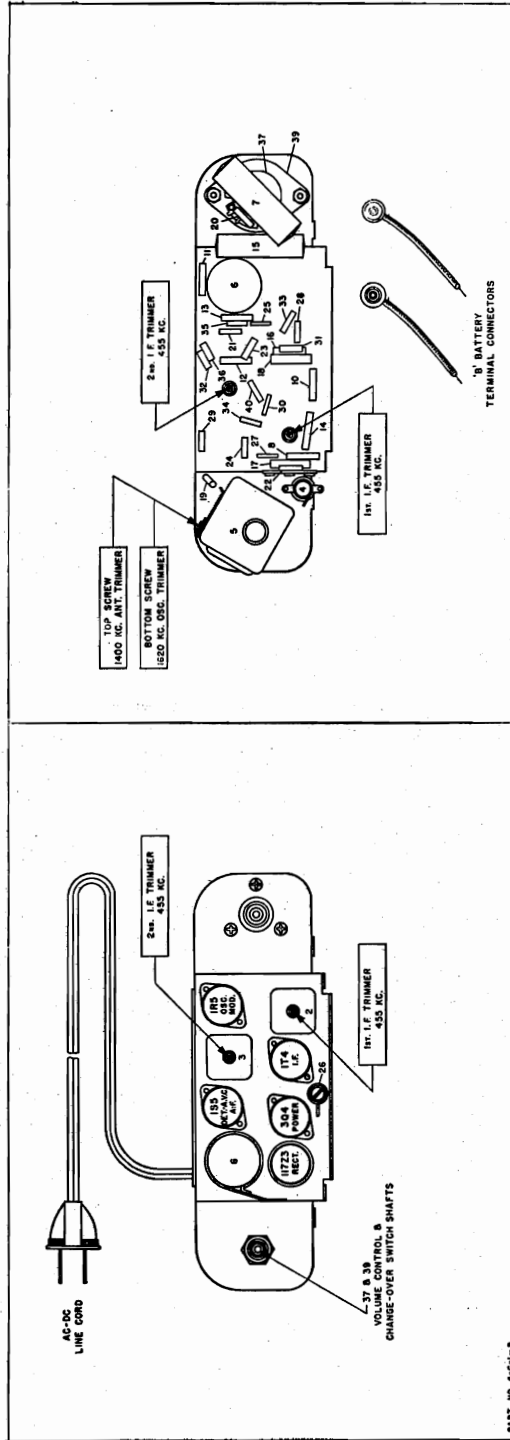

Be sure all stages are accurately aligned before measuring gain. R.F. gains can be measured with a "channel" type instrument containing a tuned and calibrated R.F. amplifier. A vacuum tube voltmeter may be used for audio gain measurements. Observe following precautions:

1. For all gain measurements connect signal generator as shown. Use 600 KC signal with 400 cycle modulation (use nearby frequency if local station interferes.)
2. Be sure radio is carefully tuned to generator signal (use weak signal for sharp tuning).
3. When using a "channel" type instrument carefully tune it for maximum output at desired frequency before making measurements.

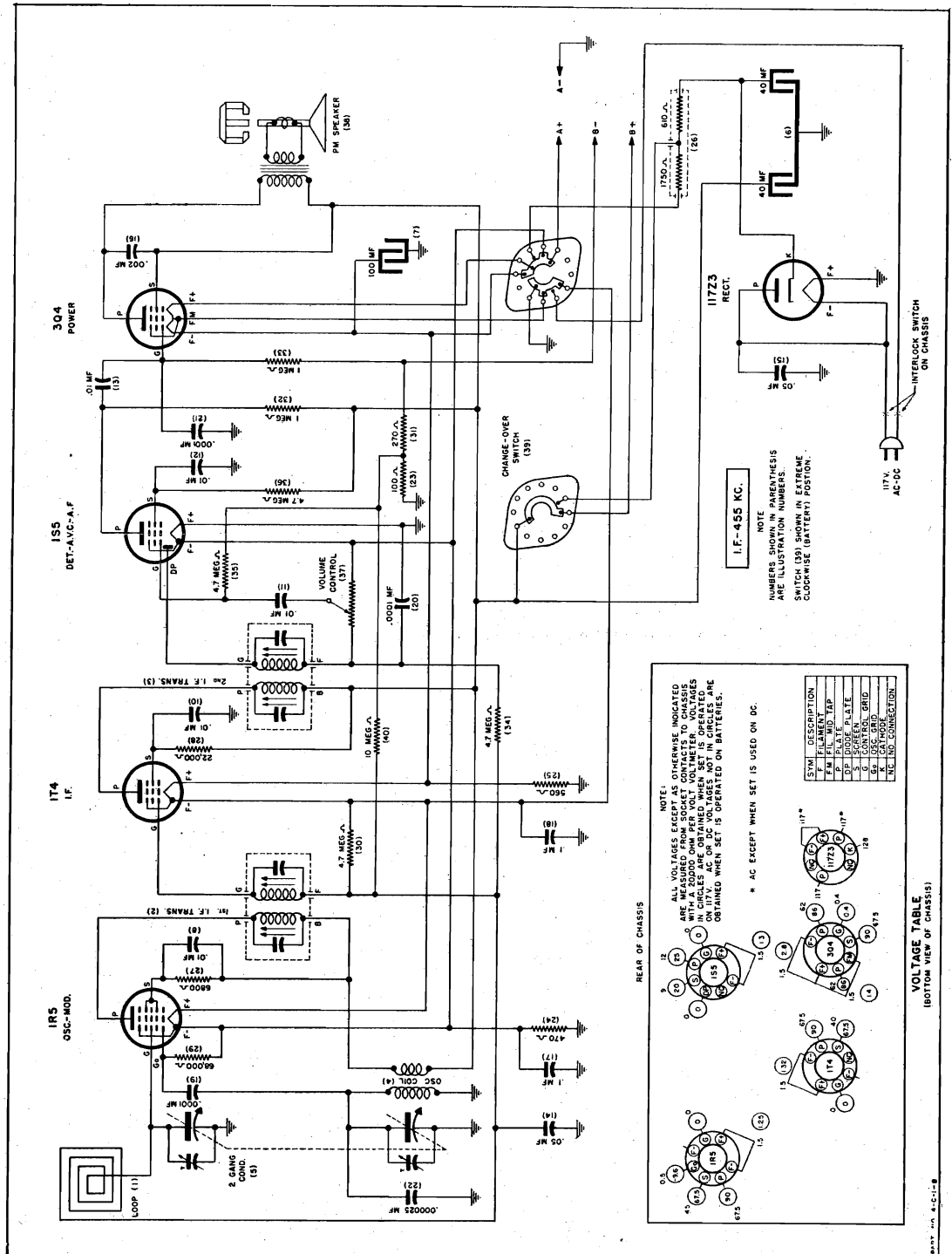

MODEL 4-C-1,
Code 291-7-564

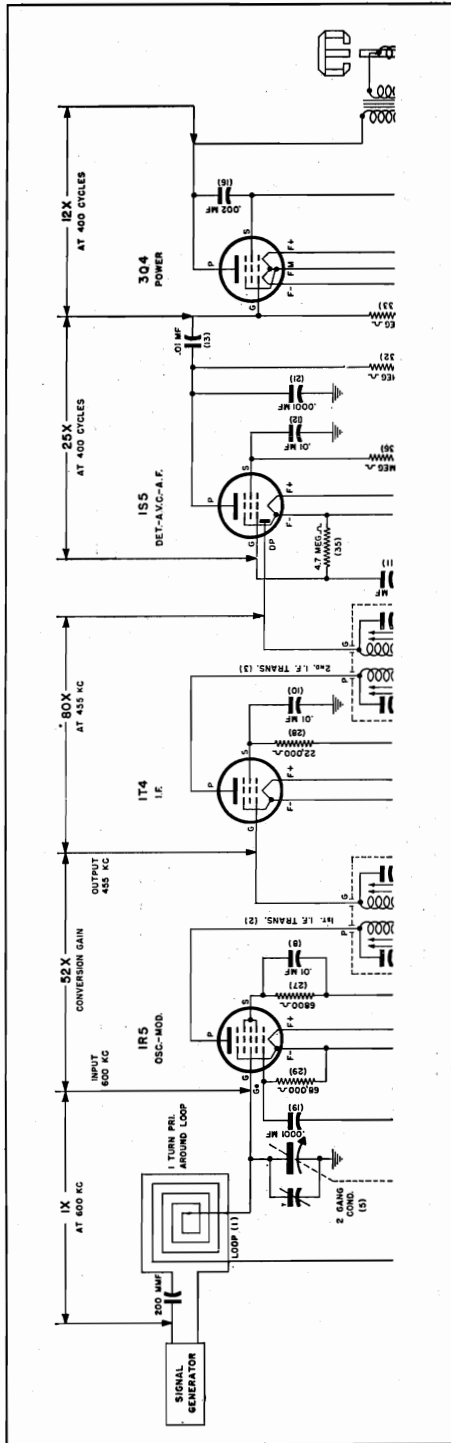

Differences in tube characteristics, tolerance of parts, adjustment of tuned circuits, and variations of line voltage will influence stage gain. Accuracy of measurements is dependent upon careful tuning of receiver to generator signal and experience in using your test equipment. These factors may create considerable variation in gain measurements.

ORDERING PARTS

Order parts from your nearest Firestone Warehouse. When ordering parts, it is important that the correct code number and stock number be given with the correct part name and part number as shown in the parts list. You will find the stock number and code number stamped on the chassis pan.

PARTS LIST

Ill. No.	Part No.	Part Name	Description	List Price	Part No.	Part Name	Description	List Price
1	20E145-1	Antenna	Door with Loop	\$4.75	23E9	Condenser	Ceramic, .0001 Mfd.	.20
2	20E141	Coil	1st I.F. Transformer	3.70	23E8	Condenser	Ceramic, .00025 Mfd.	.23
3	20E299-2	Coil	1st I.F. Transformer	3.70	27E101-7	Resistor	Carbon, 100 Ohm, 1/4 W.	.06
4	20E141	Coil	2nd I.F. Transformer	3.70	27E471-7	Resistor	Carbon, 470 Ohm, 1/4 W.	.06
5	20E299-2	Coil	2nd I.F. Transformer	3.70	27E561-7	Resistor	Carbon, 560 Ohm, 1/4 W.	.06
6	24E22	Condenser	Oscillator	1.05	27E1003*	Resistor	Wire Wound	.85
7	25E14*	Condenser	Tuning, 2 Gang	4.00	27E682-7	Resistor	Carbon, 6800 Ohm, 1/4 W.	.06
8	25E12*	Condenser	Tubular, Dry Elect. 40-40 Mfd. 150 V.	1.95	27E225-7	Resistor	Carbon, 22,000 Ohm, 1/4 W.	.06
9	23E2004-5	Condenser	Tubular, Dry Elect. 100 Mfd. 10 V.	.40	27E683-7	Resistor	Carbon, 68,000 Ohm, 1/4 W.	.05
10	23E2004-5	Condenser	Tubular, .01 Mfd. 150 V.	.40	27E475-7	Resistor	Carbon, 47 Meg Ohm, 1/4 W.	.05
11	23E2004-5	Condenser	Tubular, .01 Mfd. 150 V.	.40	27E271-7	Resistor	Carbon, 270 Ohm, 1/4 W.	.05
12	23E2004-5	Condenser	Tubular, .01 Mfd. 150 V.	.40	27E105-7	Resistor	Carbon, 1 Meg Ohm, 1/4 W.	.05
13	23E2004-5	Condenser	Tubular, .01 Mfd. 150 V.	.40	27E105-7	Resistor	Carbon, 1 Meg Ohm, 1/4 W.	.06
14	23E2004-7	Condenser	Tubular, .05 Mfd. 150 V.	.40	27E475-7	Resistor	Carbon, 4.7 Meg Ohm, 1/4 W.	.06
15	23E2004-2	Condenser	Tubular, .05 Mfd. 150 V.	.25	27E475-7	Resistor	Carbon, 4.7 Meg Ohm, 1/4 W.	.06
16	23E2004-5	Condenser	Tubular, .1 Mfd. 150 V.	.45	28E16*	Volume Control	2 Megohm	.85
17	23E2004-8	Condenser	Tubular, .1 Mfd. 150 V.	.45	28E16*	Volume Control	4 Inch P.M. with 4 No. 13E103-1	6.00
18	23E2004-8	Condenser	Tubular, .1 Mfd. 150 V.	.45	29E12*	Switch	Mounting Speed Nuts	2.25
19	23E9	Condenser	Ceramic, .0001 Mfd.	.20	27E106-7	Resistor	Carbon, 10 Meg Ohm, 1/4 W.	.06

MISCELLANEOUS PARTS

Part No.	Part Name	Description	List Price	Part No.	Part Name	Description	List Price
20E144	"A" Batt. Bkt. Assem.	Complete "A" Bkt. Assem.	\$.80	5E21	Line Cord Retainer	Fibre Plate with 4 No. 82E163F10 Mounting Screws	\$.12
5E19	"A" Batt. Bkt. Cont.	Battery Hold Down	.50	51E4	Line Cord	6 ft. Rubber Line Cord	.50
20E265	"B" Batt. Conn.	Assembly with B— and B+ Dot Snapper	.50	50E29	Shield	Metal Chassis Shield with 2 No. 82E172F10 Mounting Screws	.20
20E143-1*	Cabinet	Cabinet Complete with Loop Door, Less Strap. Mention Required Color	11.00	33E54	Shield Insulator	Fibre Insulator for Metal Shield	.05
30E69*	Cabinet	Cabinet Less Door, Less Strap. Mention Required Color	6.70	7E79	Speaker Baffle	Metal Mesh	.10
7E77-1*	Cabinet Front	Cabinet Front Only. Mention Required Color	3.65	66E14-1	Strap	Extension Strap	.14
7E78-1*	Cabinet Back	Cabinet Back Only. Mention Required Color	3.10	55E32-1	Strap	Buckle End with Bracket and 1 No. 82E727F10 Mounting Screw	.80
20E145-1*	Cabinet Door	Door with Loop Assembly, Complete. Mention Required Color	4.75	20E142-1	Strap	Tip End with Bracket and 1 No. 82E727F10 Mounting Screw	.55
20E147*	Cabinet Catch Assem.	Catch Assembly with No. 37E37-1 Slide Knob and 2 No. 82E163F10 Mounting Screws	.50	82E163F10	Screw	HARDWARE	
55E31*	Cabinet Strike	Strike Plate with 2 No. 82E163F10 Mounting Screws	.07	82E163F10	Screw	No. 4—24x1/4 Rec. B.H.	\$1.80/C
15E47	Clamp	For Line Cord with 2 No. 82E163F10 Mounting Screws	.03	82E712F10	Screw	No. 4—24x3/8 Rec. B.H.	1.90/C
20E148*	Interlock Socket Assembly	Female Socket Assembly with 1 No. 82E163F10 Mounting Screw	.30	82E727F10	Screw	No. 4—3/16 Hex Hd. No Slot Type Z	.60/C
30E31*	Interlock Plug Assembly	Male Plug Assembly with 1 No. 82E163F10 Mounting Screws	.25	47E6	Pin	Sheet Metal	.65/C
37E37-1*	Knob	Slide Knob	.17	26E35-2	Lug	Sheet Metal	.04
37E38-1*	Knob	Calibrated Dial Knob	.30	26E35-1	Lug	For Door Hinge	Each
37E39-1*	Knob	Tuning and Volume	.22	65E10	Spring	Contact Lug for Loop-Door Assembly	1.15/C
37E40-1*	Knob	Selector Switch. "OFF-AC-DC-BATT."	.32	12E15	Spring Washer	Contact Lug for Loop-Door Assembly	1.20/C

* Fast Moving Items.

Loop Door on 4-C-1

Complaint - Poor or Intermittent Reception due to open Loop Antenna.

Cause - Loop Antenna breaks at soldered connection.

Suggested Action:

It is advisable to purchase the complete loop assembly Part No. 20E145-1 and replace old one as described below.

The serviceman should not attempt to replace just a part of the loop assembly. The loop assembly consists of an inner and outer bakelite section and a loop coil. To make the loop assembly fit properly it is necessary to assemble the two bakelite sections at the same time. These sections are mates and must then be used together.

Installation of a new loop coil only is very difficult. The leads must be placed in the proper location and waxed in position, and it would be very easy to crush the loop coil when fitting the two bakelite sections together.

MODEL 4-C-1,
Code 291-7-564

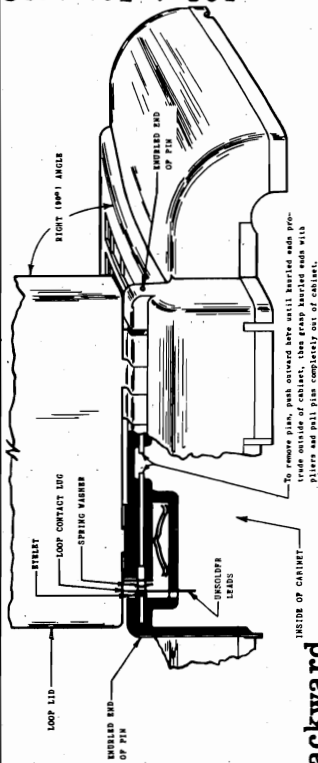

To Remove Lid From Cabinet

- (a) Open Cabinet
- (b) Remove chassis mounting screws and swing chassis slightly backward.
- (c) Unsolder the leads from the two lid lugs that project through the cabinet.
- (d) Observe position of curved pressure springs, because these must be put back in same position should they fall out during installation of new lid. Remove lid pins -- see drawing for directions -- and gently separate lid from cabinet.
- (e) To avoid damaging chassis, speaker, etc., it is advisable to remount chassis in cabinet with two screws while re-installing lid.

To Install Lid on Cabinet

- NOTE:** Do not remove tape around right and left corners of lid until it is completely installed.
- (a) Carefully pull pins out of replacement lid - be sure to leave lugs with washers and eyelets in lid exactly as shipped.
 - (b) Place both pairs of curved pressure springs in original position.
 - (c) Hold lid at right angle to front of cabinet, as shown on drawing, and feed the two lugs on lid into the two narrow slots located adjacent to the curved pressure springs, pressing inward until lid is in place. Important - keep lugs, washers and eyelets snug against lid otherwise they will jam on cabinet and prevent lid from being inserted all the way.
 - (d) Line up holes in lid and cabinet and gently push pins through these holes until end of pin is flush with edge of cabinet.
 - (e) Remove chassis mounting screws, and swing chassis back slightly. Resolder leads to the two lid lugs and remount chassis with chassis mounting screws.
 - (f) Remove tape around left and right corners of lid.

NOTE: The new loop assembly comes equipped with a longer lug. The longer lug is designed to overcome poor or intermittent reception which occurs when the lead wire is broken. Only a small quantity of these radios were produced with the short lug. Recent production comes equipped with the longer lug.

MODELS 4-A-113,
4-A-114, Code
334-3-5A3C

ELECTRICAL SPECIFICATIONS

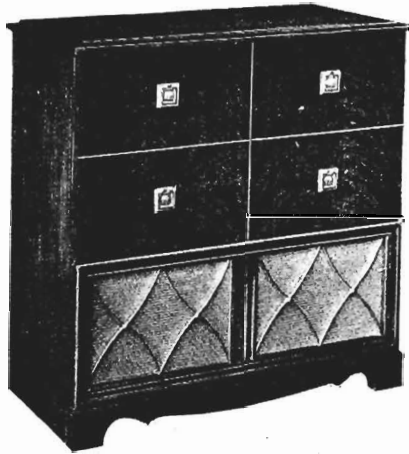

6 Tube Superheterodyne, including Rectifier Tube.
Tuning Frequency Range.....540 to 1600 KC
Power Consumption....(Radio) 35 watts (At 117 volts AC)
(Phono) 20 watts, 60 cycles only
Power Output 2.0 watt maximum, 1.1 watt (10% distortion)
Intermediate Frequency455 KC
Sensitivity10 Microvolts Average
Selectivity45 KC Wide at 1000 Times Signal
Speaker(3.2 ohm Voice Coil) 8" PM Dynamic

- Tube and Dial Lamp Complement**
- 1 6BA6 R-F Amplifier
 - 1 6BE6 Converter
 - 1 6BA6 1-F Amplifier
 - 1 6AV6 Det. & 1st Audio
 - 1 6AQ5 Output
 - 1 6X4 Rectifier
 - 1 No. 47 Dial Lamp

**ALIGNMENT PROCEDURE
RADIO**

The following is required for aligning:
An All Wave Signal Generator Which Will Provide an Accurately
Calibrated Signal at the Test Frequencies as Listed.
Output Indicating Meter, Non-Metallic Screwdriver, Dummy Antennas
— .1 mf, and 50 mmf.

Volume Control Maximum all Adjustments.
Connect Chassis to Ground Post of Signal Generator with a Short
Heavy Lead.
Allow Chassis and Signal Generator to "Heat Up" for Several
Minutes.

SIGNAL GENERATOR

FREQUENCY SETTING	CONNECT GENERATOR OUTPUT TO	THRO'UGH DUMMY ANTENNA	CONNECT GROUND TO	GANG CONDENSER SETTING	ADJUST	ADJUST FOR
455 KC	Control Grid I-F 6BA6 Pin No. 1	.1 mf	Chassis Base	Rotor Fully Open	2nd I.F. Pri. (1) and Sec. (2)	Maximum Output
455 KC	Control Grid 6BE6 Pin No. 7 1st Det.	.1 mf	Chassis Base	Rotor Fully Open	1st I.F. Pri. (4) and Sec. (3)	Maximum Output
455 KC	Control Grid 6BE6 Pin No. 7	.1 mf	Chassis Base	Rotor Fully Open	2nd I.F. Pri. (1) and Sec. (2)	Maximum Output
1620 KC	Control Grid R-F 6BA6 Pin No. 1	.1 mf	Chassis Base	Rotor Fully Open	Oscillator C-8	Maximum Output
1400 KC	Control Grid R-F 6BA6 Pin No. 1	.1 mf	Chassis Base	Turn Rotor to Max. Output. Set Pointer to 1400 KC See Note A	Interstage C-6 See Note B	Maximum Output
1400 KC	External Antenna Terminal	50 mmf	Chassis Base	Turn Rotor to Max. Output. Set Pointer to 1400 KC See Note A	Antenna C-2 See Note B	Maximum Output

NOTE A—If the pointer is not at 1400 KC on the dial, reset pointer to the 1400 KC mark on the dial scale.
NOTE B—Turn the rotor back and forth and adjust the trimmer until the peak of greatest intensity is obtained.

DRIVE CORD REPLACEMENT

DIAL POINTER CORD

Use a new S-10X77 drive cord assembly or a new length of cord 48 inches long for the installation. Install the cord as shown in the illustration, winding three turns counterclockwise around the drive shaft with the turns progressing away from the chassis. After completing the installation rotate the drive shaft a few turns to take up the slack in the cord.

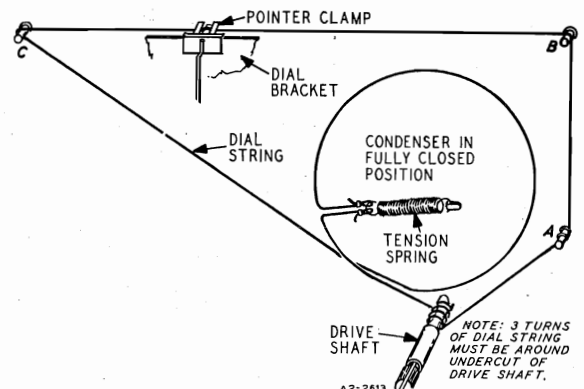

MODELS 4-A-113,
4-A-114, Code
334-3-5A3C

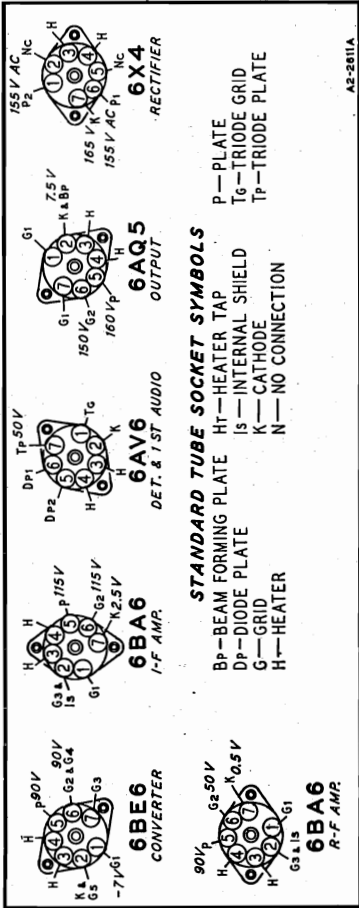
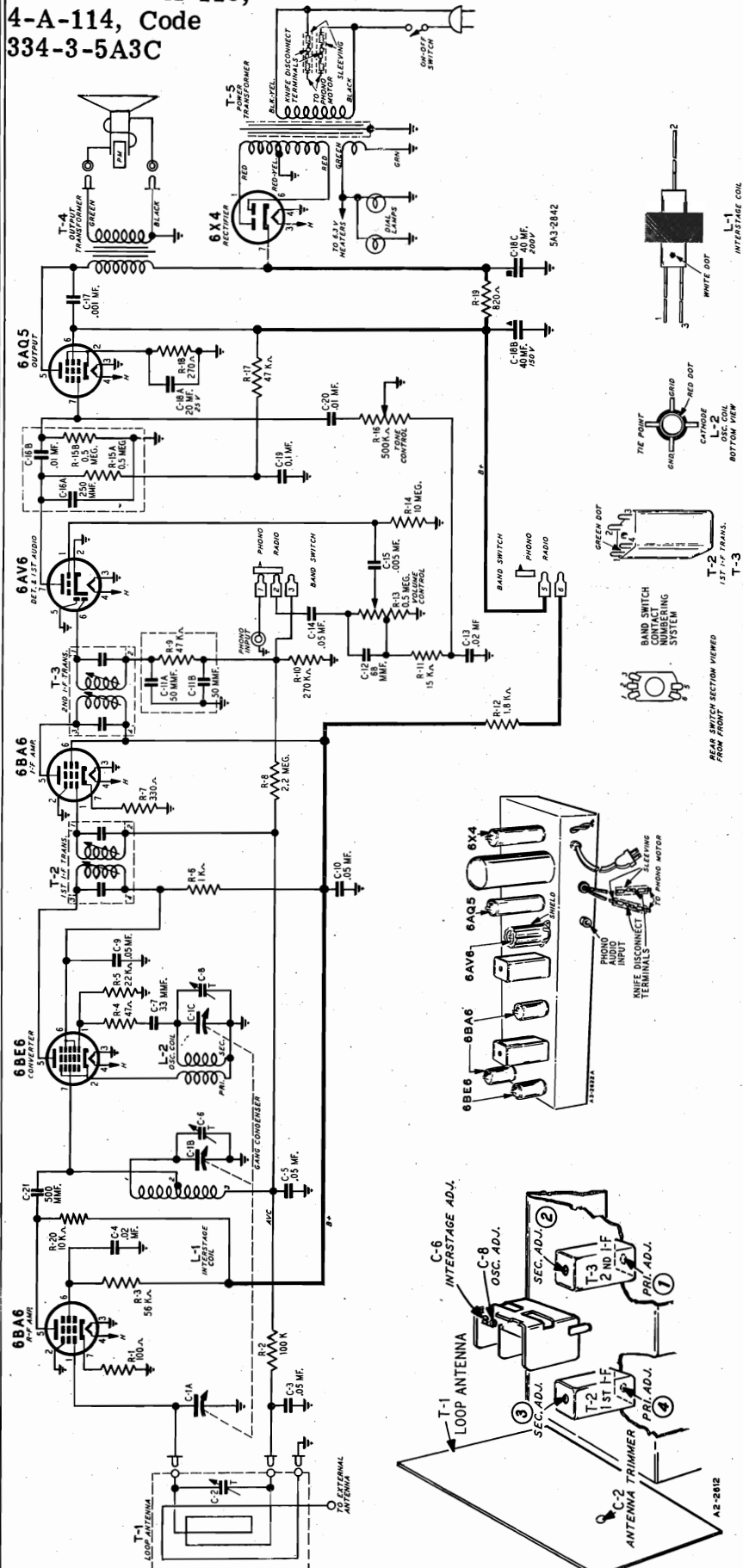

TUBE SOCKET VOLTAGES

Socket voltages are shown on the Bottom Socket diagram at the tube socket terminals. All voltages are between the socket terminal and chassis ground. Plate, screen and cathode voltages were taken with a 1000 ohm-per-volt meter with a 300 volt scale used for plate and screen voltages. Audio grid voltages were read with a vacuum tube voltmeter. Conditions of measurement are:

- Line voltage 117 Volts AC
- Signal Input
- A Variation of $\pm 10\%$ is usually permissible.

MODELS 4-A-113,
4-A-114, Code
334-3-5A3C

PARTS LIST

ORDERING PARTS

Order parts from your nearest Firestone Tire and Auto Supply Warehouse. When ordering parts, it is important that the correct code number and stock number, be given with the correct part name and part number as shown in the parts list. You will find the stock number and code number stamped on the chassis pan.

RETURNING DEFECTIVE PARTS

All parts on adjustments must be returned to your District Office Service Department with claim form completely filled out. This radio is so constructed that it can be repaired locally by an experienced repairman.

MISCELLANEOUS

		LIST PRICE
12A477	8" P.M. Speaker	\$ 7.40
10A765	Knobs	.25
4X1162	Escutcheon	1.55
2A405	Radio-Phono Switch	.85
13X546	Line Cord & Plug Assembly	.90
3A458	Tube Socket (6AV6)	.20
3A426	Tube Socket (Miniature)	.20
30X560	Line Cord Clamp	.10
3A305	Phono Socket	.10
32X403	Tube Shield (6AV6)	.10
76X1	Capacitor - Resistor Combination	.40
76X5	Capacitor - Resistor Combination	.65

CAPACITORS

C-1A } C-1B } C-1C }	14A213	Gang Condenser Assembly	3.60
C-2	17A235	2-24 mmf Trimmer	.35
C-3 } C-5 } C-9 } C-10 } C-14 }	RCP10W2503M	.05 mf 200 V Tubular	.20
C-4 } C-13 }	RCP10W2203M	.02 mf 200 V Tubular	.20
C-6 } C-8 }	Part of Gang Condenser Assembly		
C-7	47X612	33 mmf Ceramic	.25
C-11A } C-11B }	Part of 76X1 Assembly (See Miscellaneous)		
C-12	47X471	68 mmf Ceramic	.30
C-15	RCP10W4502M	.005 mf 400 V Tubular	.20
C-16A } C-16B }	Part of 76X5 Assembly (See Miscellaneous)		
C-17	RCP10W6102M	.001 mf 600 V Tubular	.20
C-18A } C-18B } C-18C }	45X381	20 mf 25 V 40 mf 150 V 40 mf 250 V	Dry Electrolytic 2.25
C-19	RCP10W2104M	.1 mf 200 V Tubular	.25
C-20	RCP10W2103M	.01 mf 200 V Tubular	.20
C-21	47X508	500 mmf Ceramic	.25

RESISTORS

		Ohms	Watts	LIST PRICE
R-1	B84101	100	0.5 Carbon	.15
R-2	B85104	100K	0.5 Carbon	.10
R-3	B84563	56K	0.5 Carbon	.15
R-4	B84470	47	0.5 Carbon	.15
R-5	B85223	22K	0.5 Carbon	.10
R-6	B84102	1K	0.5 Carbon	.15
R-7	B84331	330	0.5 Carbon	.15
R-8	B85225	2.2 meg.	0.5 Carbon	.10
R-9	Part of 76X1 Assembly (See Miscellaneous)			
R-10	B84274	270K	0.5 Carbon	.10
R-11	B84153	15K	0.5 Carbon	.10
R-12	C85182	1.8K	1.0 Carbon	.15
R-13	36X372	0.5 meg.	Volume Control	1.20
R-14	B85106	10 meg.	0.5 Carbon	.10
R-15A } R-15B }	Part of 76X5 Assembly (See Miscellaneous)			
R-16	40X310	500K	Tone Control	.80
R-17	B85473	47K	0.5 Carbon	.15
R-18	B84271	270	0.5 Carbon	.15
R-19	D84821	820	0.2 Carbon	.30
R-20	B84103	10K	0.5 Carbon	.15

TRANSFORMERS AND COILS

L-1	9A2289	Interstage Coil	.80
L-2	9A2113	Oscillator Coil	.50
T-1	9A2152	Loop Antenna	2.30
T-2	9A2112	1st I-F Transformer	1.60
T-3	9A2063	2nd I-F Transformer	1.60
T-4	51X134	Output Transformer	2.60
T-5	53X291	Power Transformer	7.35

DIAL AND DRIVE ASSEMBLY

S-10X77	Drive Cord Assembly	.20
15X251	Pointer	.15
25X1616	Dial Bracket	1.50
58X766	Dial Glass	1.15
26X524	Drive Shaft	.85
7A199	Pilot Light Socket Assembly	.45
7A103	No. 47 Dial Light	.25
28X113	Drive Cord Tension Spring	.30
41X88	Dial Light Reflector	.15
19X192	"C" Washer (Mtg. Drive Shaft)	.10

TYPE V-28A189 RECORD CHANGER PARTS

See Note	Motor Assembly, 60 cycles	
	105-125 Volts AC	
V-2503B	Pickup Arm	2.00
P-77V	Crystal Cartridge & Needles	14.00
85-16	Needle, Regular	3.10
85-18	Needle, Microgroove, Red	3.10
NOTE	Specify part number stamped on motor assembly.	

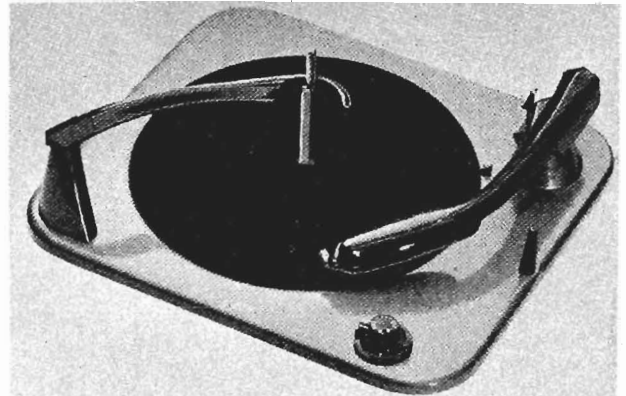

Use only genuine factory tested parts to insure service jobs you can depend on and to obtain original set performance.

PRICES SUBJECT TO CHANGE WITHOUT NOTICE

MODEL 4-A-115,
Code 120-3-326

Your new "Treasure Chest" receiver is a six tube (including rectifier) superheterodyne, designed to operate on 115 to 125 volts, AC or DC power. The receiver covers the frequency range 538 to 1620 KC. This receiver is equipped with a Radio Frequency Amplifier and the newly designed "Magna-Loop" Antenna, thereby insuring the utmost in sensitivity.

VOLUME CONTROL KNOB

This knob is located on the left side of the radio. Turning this knob will put the radio into operation. Turning this knob further to the right will increase the volume. After a station has been selected, the volume control should be adjusted to the desired level.

STATION SELECTOR KNOB

This knob is located on the right side of the radio. The knob should be turned until desired station has been selected.

This receiver contains the following tubes:

- 1-12BE6 Mixer
- 2-12BA6 R.F., I.F. Amplifier
- 1-12AT6 or 12AV6 Detector-AVC-1st Audio
- 1-35C5 Power Output
- 1-35W4 Rectifier

ALIGNMENT PROCEDURE

Volume Control — Maximum, all adjustments.
No signal applied to antenna.
Power Input — 115 to 125 volts, AC or DC.

Connect dummy antenna in series with output lead of signal generator.
Connect ground lead of signal generator to common ground above chassis.

Dial Setting	Generator Frequency	Dummy Antenna	Generator Connection	Trimmer Reference	Trimmer Adjustment	Trimmer Function
1. Fully open	455 KC	.1 MFD	12BE6 Grid	L5 Top & Bot.	Maximum	Output I.F.
2. Fully open	455 KC	.1 MFD	12BE6 Grid	L4 Top & Bot.	Maximum	Input I.F.
3. Fully open	1620 KC	.1 MFD	12BE6 Grid	CV2	Maximum	Oscillator
4. Fully open	455 KC	.1 MFD	12BA6 Grid	CTI	Minimum	I.F. Trap
5. Tune in signal from generator	1400 KC		Loosely couple signal generator to "Magna Loop"	CV1	Maximum	Antenna R.F. Trimmer

Repeat alignment procedure as a final check.

SERVICE NOTES

To remove the chassis for servicing, remove the cabinet back, volume control knob and tuning knob. Then remove the four chassis screws from the bottom of the cabinet.

ELECTRICAL SPECIFICATIONS

- Power Supply 115 to 125 volts AC-DC
- Frequency Range 538 to 1620 KC.
- Speaker 6 inch PM
- Power Output 1.5 watts maximum

TUBE PLACEMENT AND ALIGNMENT CHART

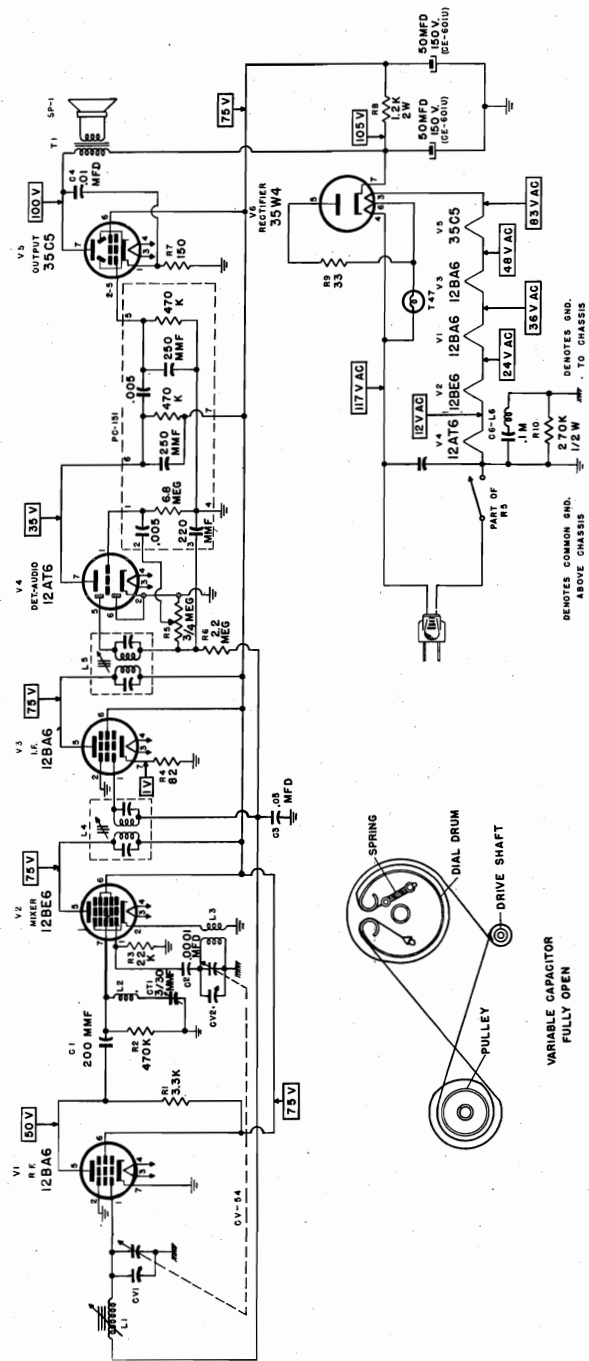
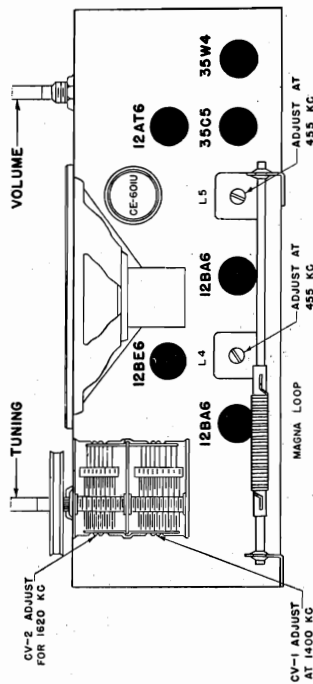

MODEL 4-A-115,
Code 120-3-326

ORDERING PARTS

Order parts from your nearest Firestone Tire and Auto Supply Warehouse. When ordering parts, it is important that the correct code number and stock number be given with the correct part name and part number as shown in the parts list.

PARTS LIST

Schematic Diagram Reference	Part No.	Description	List Price
CONDENSERS			
C1	CC201	200 MMFD Ceramic	.25
C2	CC101	100 MMFD Ceramic	.25
C4	C103-6	.01 MFD, 600 VDCW	.30
C5 C3	C1473-4	.047 MFD, 400 VDCW, Molded	.40
C6-L6	C14L	.1 MFD Condenser-Choke Assembly	.50
CT 1	CT 3/30	Trimmer Condenser	.50
CE-601U	CE-601U	Dual 50 MFD, 150 VDCW Electrolytic	2.50
CV1, CV2	CV-54	2 section variable	2.75
RESISTORS			
R1	R332	3300 ohm, 1/2 watt, 20%	.10
R2	R474	470K ohm, 1/2 watt, 20%	.10
R3	R223	22K ohm, 1/2 watt, 20%	.10
R4	R820	82 ohm, 1/2 watt, 20%	.10
R5	RV-100	1/4 megohm volume control	1.50
R6	R225	2.2 megohm, 1/2 watt, 20%	.10
R7	R151	150 ohm, 1/2 watt, 20%	.10
R8	R122-2	1200 ohm, 2 watt, 20%	.30
R9	R330	33 ohm, 1/2 watt, 20%	.10
R10	R274	270K ohm, 1/2 watt, 20%	.10
COILS AND TRANSFORMERS			
L1	L-A26	Magna-Loop Antenna	1.50
L2	L-326	I.F. Trap Coil	1.00
L3	L-204	R.F. Oscillator Coil	1.00
L4, L5	1655-16	I.F. Transformer	2.00
T1		Output Transformer; (part of speaker; not furnished separately)	
MISCELLANEOUS			
	H324	Cabinet	12.00
	H326	Cabinet Back	.90
	H208	Clip, Coil Mounting	.05
PC-151	PC-151	Couplate	1.90
	H65	Knob, each	.30
	CD-54	Line Cord	.80
SP-1	PM327	Speaker, 6" PM, includes Output Transformer	7.80
DIAL PARTS			
	H55	Dial Ring, Plastic	2.00
	DS326	Drive Shaft Assy	.45
	T-47	Pilot Light	.15
	H56	Pointer	.25
	H544	Pulley, Dial	.05
	H547	Pulley Mounting Bracket	.75
	H201	Rubber Grommet	.05
	H105	Spring, Dial Drive String	.10
	H548	Tension String	.05

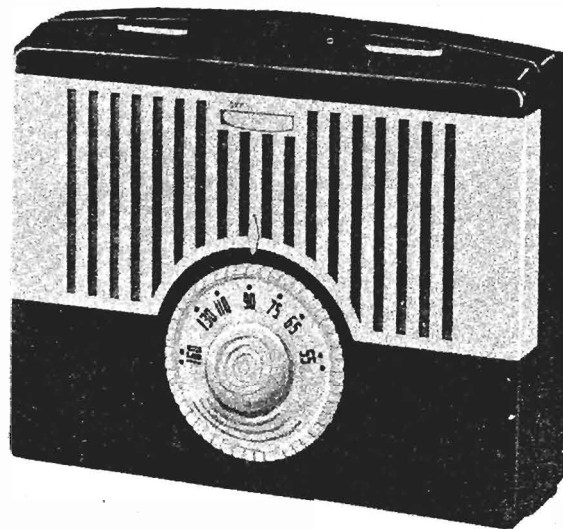

SPECIFICATIONS

CABINET DIMENSIONS (INC. KNOBS)

8⁵/₈" x 3³/₈" x 7¹/₈"

WEIGHT—4 LBS. (APPROX.)

TUNING RANGE—535-1675 K.C.

INTERMEDIATE FREQ.—455 K.C.

LOUD SPEAKER—3¹/₂" P.M.

VOICE COIL IMPEDANCE—3.2 OHMS AT
400 CYCLES

POWER OUTPUT —

UNDISTORTED—.095 W.

MAXIMUM—.145 W.

POWER SUPPLY—BATTERIES

TWO—1¹/₂ VOLT "A"—FIRESTONE —
#4-D-71

ONE—67¹/₂ VOLT "B"—FIRESTONE —
#4-D-72

TUBE COMPLEMENT —

1R5—CONVERTER

1U4—I.F. AMPLIFIER

1U5—DET.-AUDIO AMPLIFIER

3V4—POWER OUTPUT

ALIGNMENT PROCEDURE

For alignment procedure read tabulations from left to right and make the adjustments marked (1) first. (2) next. (3) third.

Before starting alignment:

- (A) LOOSEN THE CHASSIS FROM THE CABINET BY REMOVING THE BATTERY CONNECTORS FROM THE BATTERIES, PULLING OFF THE TUNING KNOB AND REMOVING THE TWO SCREWS ON THE CABINET FRONT WHICH FASTEN THE CHASSIS TO THE CABINET.
- (B) USE AN ACCURATELY CALIBRATED TEST OSCILLATOR WITH SOME TYPE OF OUTPUT MEASURING DEVICE.

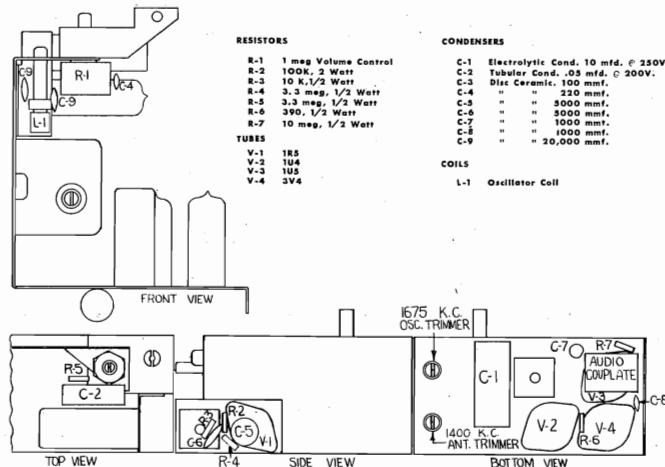

MODEL 4-A-116,
Code 120-3-426,
The Wellington

ELECTRICAL SPECIFICATIONS

Power Supply 115 to 125 volts AC
 Frequency Range 538 to 1620 KC.
 Speaker 6 inch PM
 Power Output 1.5 watts maximum

ALIGNMENT PROCEDURE

Volume Control — Maximum, all adjustments.
 No signal applied to antenna.
 Power Input — 115 to 125 volts, AC

Connect dummy antenna in series with output lead of
 signal generator.
 Connect ground lead of signal generator to common
 ground above chassis.

Dial Setting	Generator Frequency	Dummy Antenna	Generator Connection	Trimmer Reference	Trimmer Adjustment	Trimmer Function
1. Fully open	455 KC	.1 MFD	12BE6 Grid	L5 Top & Bot.	Maximum	Output I.F.
2. Fully open	455 KC	.1 MFD	12BE6 Grid	L4 Top & Bot.	Maximum	Input I.F.
3. Fully open	1620 KC	.1 MFD	12BE6 Grid	CV2	Maximum	Oscillator
4. Fully open	455 KC	.1 MFD	12BA6 Grid	CT1	Minimum	I.F. Trap
5. Tune in signal from generator	1400 KC		Loosely couple signal generator to "Magna Loop"	CV1	Maximum	Antenna R.F. Trimmer

Repeat alignment procedure as a final check.

SERVICE NOTES

To remove the chassis for servicing, remove the tone control knob, phono-radio knob, volume control knob and tuning knob. Disconnect phono input plug and phono motor plug. Remove the four woodscrews from the bottom of the cabinet, tilt the chassis diagonally and slide chassis out through bottom of cabinet.

TUBE PLACEMENT AND ALIGNMENT CHART

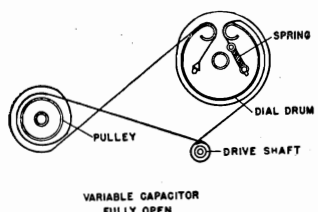
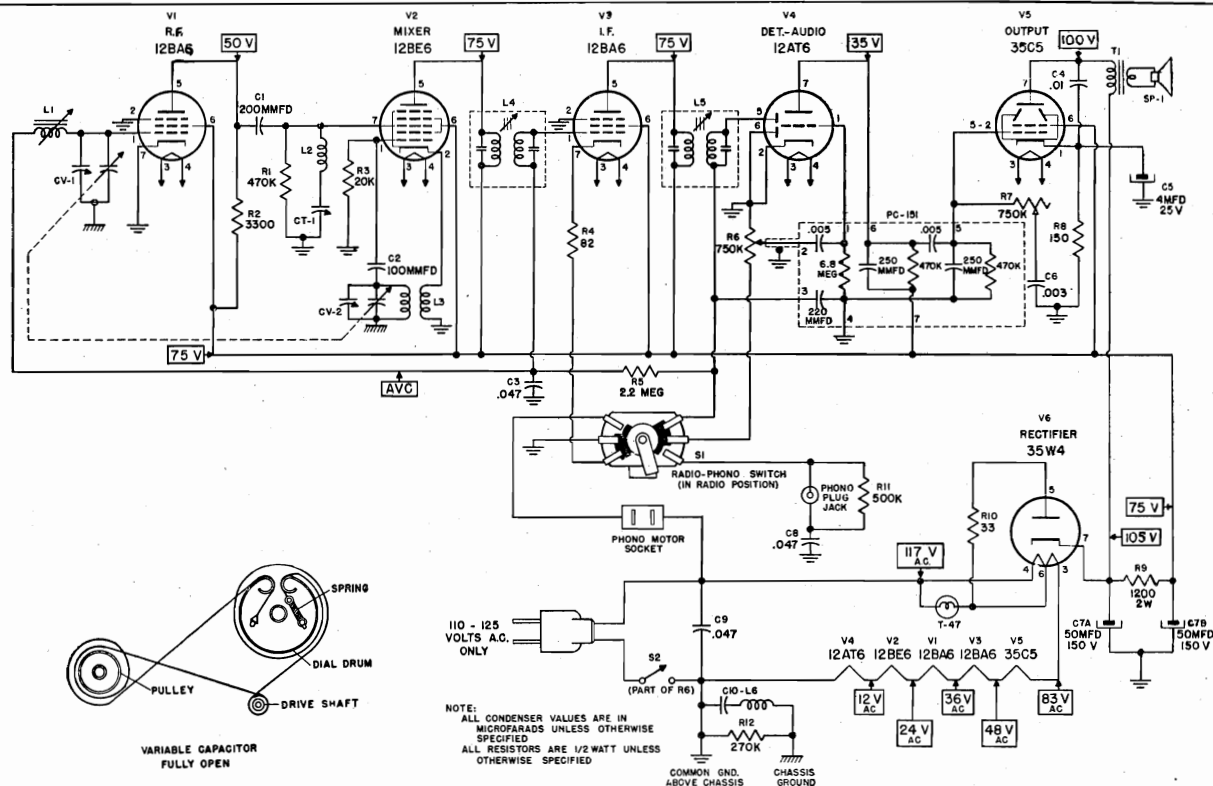
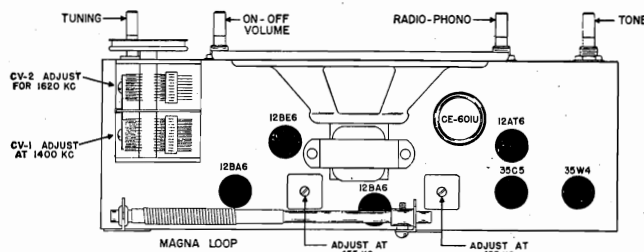

MODEL 4-A-116,
Code 120-3-426,
The Wellington

PHONOGRAPH OPERATION

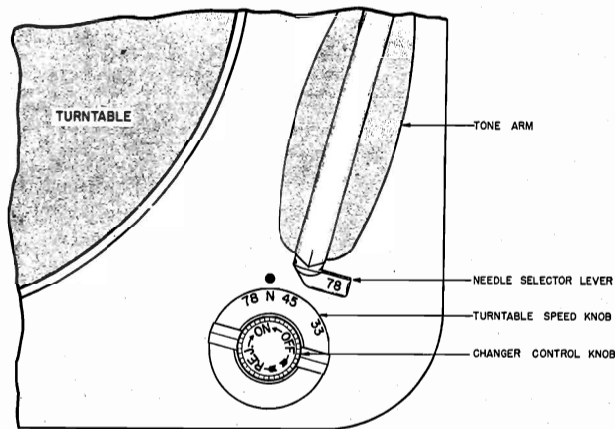

FIG. 1 CHANGER CONTROL DETAIL

SHIPPING BOLTS: Before operating your "Tri-O-Matic" Record Changer, the machine must be floated freely on the mounting springs. During shipment the mechanism is secured by two shipping bolts located on either side of the turntable. Remove the bolts and the washers underneath the bolt heads. Your record changer is now ready to operate.

RECORDS: Your new "Tri-O-Matic" changer will automatically play ten-12" either standard or long-play records, twelve-10" standard or long-play records, any assortment of ten-12" and 10" records of the same speed, or twelve-7" long-play or fine-groove records.

NOTE: Standard (78 RPM), fine-groove (45 RPM) and long-play (33 $\frac{1}{3}$ RPM) records cannot be intermixed. Turntable speed knob must be set for each type of recording.

To PLAY FINE-GROOVE (45 RPM) RECORDS:

Your "Tri-O-Matic" record changer is equipped with a special automatic spindle designed for playing 45 RPM fine-groove records. When playing other types of records, it will be necessary to remove this spindle. When replacing the spindle, place over the regular changer spindle with "45" to the front of the changer. Be certain that spindle is seated firmly.

1. Raise the cabinet lid to its full height. Lift the record support arm and swing it to the left until the shaft pin drops into the locating groove.
2. Place records on "45" spindle and lower to retaining ears. Hold records level and replace record support over spindle.
3. Select fine-groove needle by turning Needle Selector Lever to "33-45" position (See Fig. 1).
4. Set Turntable Speed Knob to "45" position. (See Fig. 1.)
5. Turn the Radio-Phono switch to the right for phono operation.
6. Turn the phonograph on by turning the Volume Control Knob to the right.
7. Start the changer by turning the Changer Control Knob (Fig. 1) to "REJ" and releasing. Changer will then play all records on the spindle and automatically shut off after the last record has been played.
8. Adjust the volume control and tone control as desired.

To PLAY STANDARD RECORDINGS: (78 RPM):

1. Raise cabinet lid to its full height. Lift the record support arm and swing it to the left until shaft pin drops into locating groove. Remove "45" spindle by lifting it straight up and off the regular changer spindle.
2. Place records on changer spindle and lower to offset shelf. Hold records level and replace record support over spindle.
3. Turn Needle Selector Lever to "78" position. (See Fig. 1.)
4. Set Turntable Speed Knob to "78" position. (See Fig. 1.)
5. Turn Radio-Phono Switch to the right for phono operation. Turn phonograph on with Volume Control Knob.
6. Turn Changer Control Knob to "REJ" and release. Changer will operate automatically until the last record has been played.
7. Adjust volume and tone controls as desired.

To PLAY LONG-PLAY (33 $\frac{1}{3}$ RPM) RECORDS:

1. Raise cabinet lid to its full height. Lift the record support arm and swing it to the left until the shaft pin drops into the locating groove. Remove "45" Spindle by lifting it straight up and off of regular changer spindle.
2. Place records on changer spindle and lower to offset shelf.
3. Turn Needle Selector Lever to "33-45" position. (See Fig. 1.)
4. Set Turntable Speed Knob to "33" position. (See Fig. 1.)
5. Turn Radio-Phono Switch to right for phono operation. Turn phonograph on with Volume Control Knob.
6. Turn Changer Control Knob to "REJ" and release. Changer will operate automatically until the last record has been played.
7. Adjust volume and tone control as desired.

REJECTING: To reject a record any time while changer is operating, turn Changer Control Knob to "REJ" and release.

STOPPING: To turn off changer before automatic shut-off, turn Changer Control Knob to "OFF". Remove unplayed records from spindle. Lift Tone Arm and place on rest.

UNLOADING: Raise cabinet top to its full height. Lift the record support arm and swing it to the left until the shaft pin drops into locating groove. Lift stack of records straight up and off spindle.

MANUAL OPERATION: To play single records or home recordings, allow the changer to go through its complete shut-off cycle. Lift the record support arm and swing it to the left until the shaft pin drops into locating groove. Place record on spindle and lower to offset shelf. Tilt the record down toward the rear of the Tone Arm. Rotate the record a half turn so that the record spins down over the spindle to the turntable. Set Turntable Speed Knob and Needle Selector Lever for the type of record to be played. Turn Radio-Phono Switch to the right for phono operation. Turn phonograph on with Volume Control Knob. Turn Changer Control Knob to "ON" position only. Raise Tone Arm and place in lead-in groove of record. Adjust tone and volume as desired.

REPEATING OF RECORDS: To repeat records, swing record support arm clear of spindle, place record on turntable and start changer. Record repeats until Changer Control Knob is turned "OFF". If a 12-inch record is to be repeated, wait for the changer to finish cycling and re-position the Tone Arm manually to the lead-in groove of the record.

SUGGESTIONS: When loading and unloading the changer, use care to prevent bending of the spindle or enlargement of the center hole of the records. Records should not be left on the spindle except during operation of the changer, in order to avoid warping of the records. *Never move or handle Tone Arm when machine is in cycle.* When machine is not in use, it is suggested that the Tone Arm be secured in the clamping bracket provided, and the Turntable Speed Knob be left in the "N" position. The Cabinet Lid should be closed when the machine is not in use. For best reproduction keep needle and records clean. Store records flat, in folders or in albums. Do not lay record on record.

MODEL 4-A-116,
Code 120-3-426,
The Wellington

ORDERING PARTS

Order parts from your nearest Firestone Tire and Auto Supply Warehouse. When ordering parts, it is important that the correct code number and stock number be given with the correct part name and part number as shown in the parts list.

PARTS LIST

Schematic Diagram Reference	Part No.	Description	List Price
CONDENSERS			
C1	CC201	200 MMFD Ceramic	\$.25
C2	CC101	100 MMFD Ceramic	.25
C3, C8, C9	CI473-4	.047 MFD, 400 VDCW	.40
C4	CI03-6	.01 MFD, 600 VDCW	.30
C5	CE-504	4 MFD @ 25 VDCW Electrolytic	.60
C6	C502-2	.005 MFD, 200 VDCW	.25
C7A, B	CE-601U	Dual 50 MFD, 150 VDCW Electrolytic	2.50
C10-16	C14L	.1 MFD, 400 VDCW Condenser-Choke Assy	.50
CT-1	CT 3/30	Trimmer Condenser	.50
CV1, CV2	CV-54	2 section variable	2.75
RESISTORS			
R1, R11	R474	470K ohm, 1/2 watt, 20%	.10
R2	R332	3300 ohms, 1/2 watt, 20%	.10
R3	R203	20K ohm, 1/2 watt, 20%	.10
R4	R820	82 ohm, 1/2 watt, 20%	.10
R5	R225	2.2 meg, 1/2 watt, 20%	.10
R6	RV-100	750K ohm volume control	1.50
R7	RV-152	750K ohm tone control	1.00
R8	R151	150 ohm, 1/2 watt, 20%	.10
R9	R122-2	1200 ohm, 2 watt, 20%	.30
R10	R330	33 ohm, 1/2 watt, 20%	.10
R12	R274	270K ohm, 1/2 watt, 20%	.10
COILS AND TRANSFORMERS			
L1	LA-26	Magna-Loop Antenna	1.50
L2	L-326	IF Trap Coil	1.00
L3	L-204	RF Oscillator Coil	1.00
L4, L5	1655-16	IF Transformer	2.00
T1		Output transformer (Part of speaker, not furnished separately)	
MISCELLANEOUS			
	H426	Cabinet, complete with lid & hinges	34.00
	H208	Clip, coil mounting	.05
	PC-151	Complate	1.90
	X226	Felt Foot	.20
	I426	Jack, Phono Plug	.30
	H65	Knob, each	.30
	CD-54	Line cord	.80
	AR152	Socket, Photo Motor	.40
SP-1	PM-327	Speaker, 6" PM includes output transformer	7.80
S-1	SW-601	Switch, phono-radio	.70
DIAL PARTS			
	H55M	Dial Ring, Plastic	2.00
	DS326	Drive Shaft Assy	.45
	T-47	Pilot Light	.15
	PS-755	Pointer	.25
	H544	Pulley, Dial	.05
	H547	Pulley Mounting Bracket	.05
	H201	Rubber Grommet	.75
	H105	Spring, Dial Drive String Tension	.10
	H548	String	.05

This receiver contains the following tubes:

1-12BE6	Mixer
2-12BA6	R.F., I.F. Amplifier
1-12AT6 or 12AV6	Detector-AVC-1st Audio
1-35C5	Power Output
1-35W4	Rectifier

MODEL 15RA2-43-8230A

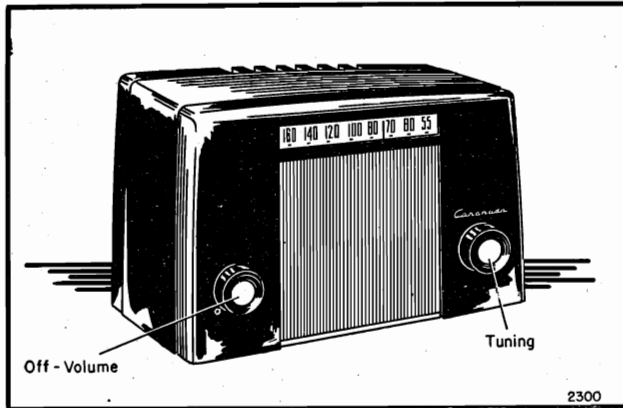

SERVICE DATA

POWER SUPPLY.....115 volts, DC or 50-60 cycle AC,
 24 watts.
 FREQUENCY RANGE.....540 to 1600 Kc.
 INTERMEDIATE FREQ...455 Kc.
 SELECTIVITY.....At 1000 Kc., 60 Kc. at 1000 x signal.
 SENSITIVITY.....150 u. v. per meter.
 POWER OUTPUT.....0.8 watt undistorted, 1.0 watt max.
 LOUD SPEAKER.....4" round PM., v. c. impedance 3.2 ohms.
 TUBE COMPLEMENT.....
 12BE6, Converter. AVC, Audio.
 12BA6, I-F Amplifier. 50C5, Output Amplifier.
 12AV6 or 12AT6, Detector, 35Z5, Rectifier.

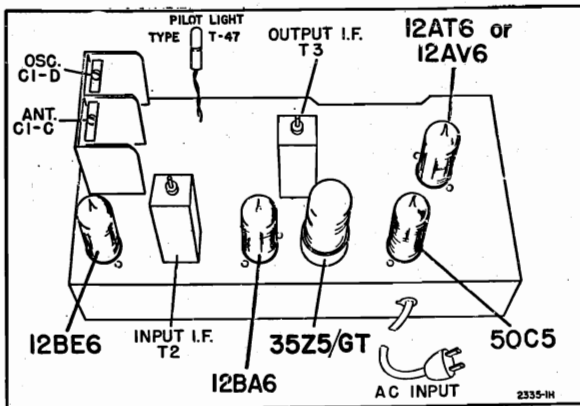

Chassis View

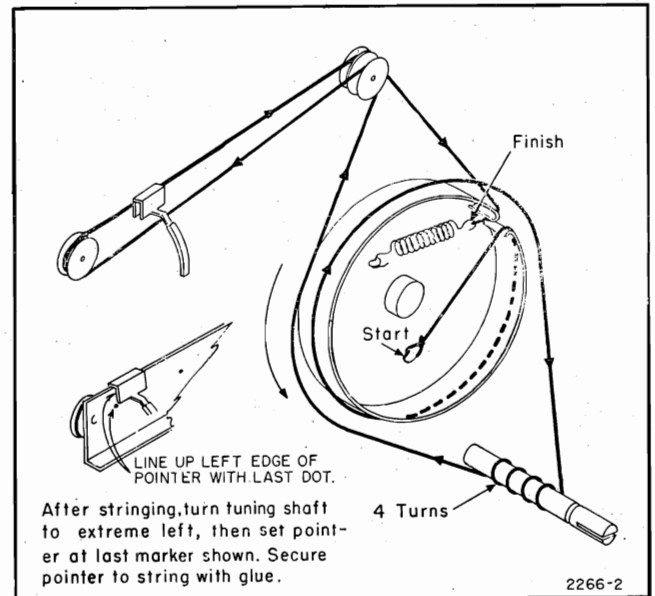

Dial Stringing Diagram

ALIGNMENT PROCEDURE

SIGNAL GENERATOR				TUNER SETTING	ADJUST FOR MAXIMUM OUTPUT	INPUT FOR 50 MILLIWATT OUTPUT
Frequency	Coupling Capacitor	Connection to Radio	Ground Connection			
455 kc.	.1 mf.	12BE6, Pin 7	HEAVY BUSS LEAD ACROSS CENTER OF CHASSIS	Capacitor full open (plates out of mesh)	Top and bottom Cores in output and input I.F. cans	65 microvolts
1620 kc.	.1 mf.	12BE6, Pin 7		Capacitor full open (plates out of mesh)	Oscillator trimmer C1-D on gang	70 microvolts
535 kc.	.1 mf.	12BE6, Pin 7		Capacitor fully closed	Check for adequate range	70 microvolts
1400 kc.		Lay Generator lead near back of cabinet		Tune in 1400 kc. signal	Antenna trimmer C1-C on gang	200 to 400 microvolts
400 cycles	.1 mf.	12AT6, Pin 1				.06 volts

603-315

MODEL 15RA2-43-8230A

SCHEMATIC DIAGRAM WITH VOLTAGES

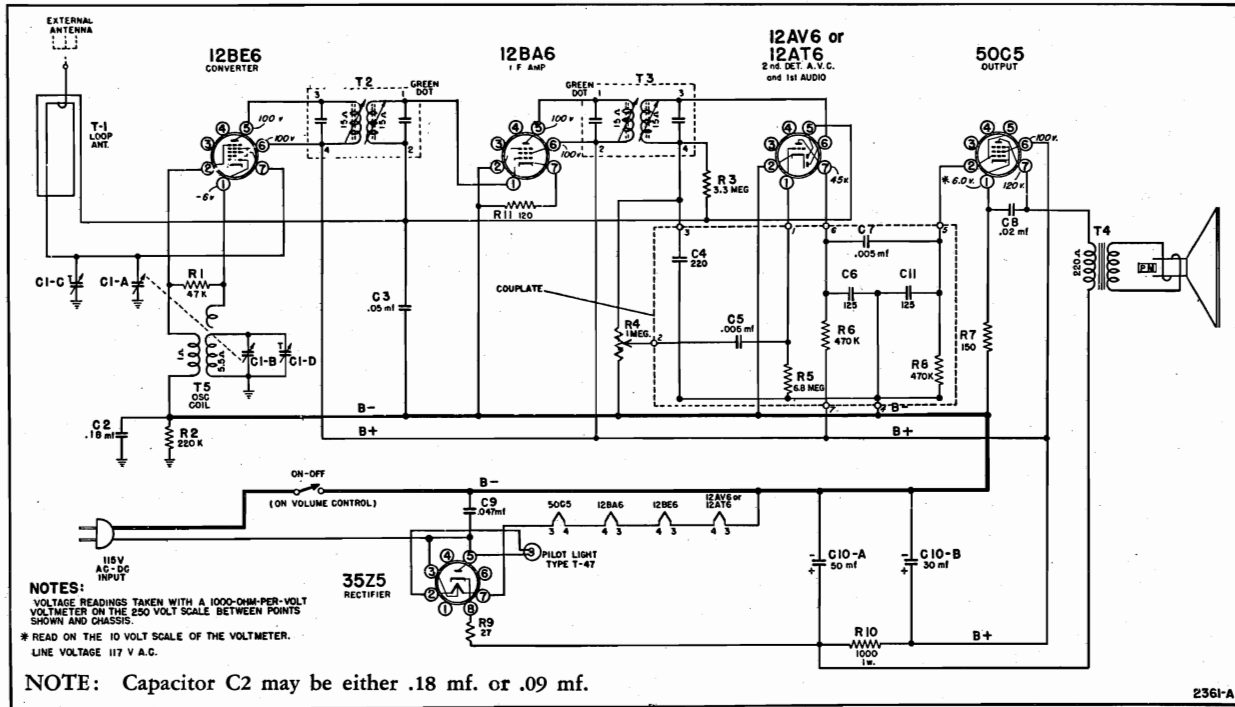

PARTS LIST

Use Only Genuine Factory Replacement Parts

Ref. No.	Part No.	Description	Qty. Used in Set	Ref. No.	Part No.	Description	Qty. Used in Set
Condensers							
C1A, B	8A-17377	Gang tuning condenser	1	2M-19187	Tube shield base	2	
C1C, D		Trimmers on gang		2H-17588 or	Tube shield	2	
C2	8D-11251	.09 mfd x 400 volts, paper	1	2H-19188	Tube shield	2	
C3	8D-11111	.18 mfd x 400 volts, paper	1	2M-17580	I.F. locking clip	2	
C4-5-6-7-11, and R5-6-8	201-19303	Couplate	1	2D-15432-3	Loop mounting bracket	1	
C8	8D-10774	.02 mfd x 400 volts, paper	1	23A-10344	Line cord lock	1	
C9	8J-16081	.047 mfd x 400 volts, molded	1	14M-10088-4	AC line cord and plug	1	
C10A, B	8C-17391	Electrolytic condenser	1	Dial Parts			
Resistors							
R1	9B1-82	47K ohms, 1/2 watt, 10%	1	3A-18612	Tuning shaft	1	
R2	9B1-27	220K ohms, 1/2 watt, 20%	1	2D-17584	Support bracket	1	
R3	9B1-34	3.3 megohms, 1/2 watt, 20%	1	40A-17591	Bushing	1	
R4	10A-18650	Volume control (1 megohm) and switch	1	29E-17592	Spring washer	1	
R5-6-8		See couplate	43D-17609	Tinnerman clip	1	
R7	9B1-52	150 ohms, 1/2 watt, 10%	1	29C-10630	"C" washer	1	
R9	9B1-43	27 ohms, 1/2 watt, 10%	1	53A-18547	Dial string (approx 40")	1	
R10	9B2-62	1000 ohms, 1 watt, 10%	1	49A-11324	Take-up spring	1	
R11	9B1-51	120 ohms, 1/2 watt, 10%	1	2C-18618	Slide plate, L. H.	1	
Transformers and Coils							
T1	13E-18653	Loop antenna	1	2C-18618-1	Slide plate, R. H.	1	
T2-3	13B-17731	Input I.F. transformer	1	25B-18643	Rubber bumper	4	
T4	12C-17595 or	Audio output transformer	1	2C-18616	Dial cross bar	1	
T4	12C-19302	Audio output transformer	1	3M-18614	String guide	2	
T5	13D-17583	Oscillator coil	1	47A-18613	Pilot light assembly	1	
Miscellaneous							
	18A-18656	4" PM speaker	1	46A-10793	Pilot light bulb	1	
	15B-10440	8-prong, tube socket	1	2G-18615	Dial pointer	1	
	15C-16007	7-prong, tube socket	4	55A-16384	Red tubing for pointer	1	
	2M-17589 or	Tube shield base	2	Cabinet Parts			
				5C-16147-75	Bakelite cabinet	1	
				5B-18657-68	Knob	2	
				6D-16383	Dial scale	1	
				2M-16401	Spring clip	1	
				2M-18654	Grill trim strip	1	
				2M-18652	Speaker grille	1	
				23J-18651	Cardboard baffle	1	
				23K-18658	Black crinoline cloth	1	
				23M-18617	Bottom cover	1	
				42A-14448	Chassis bolts	4	

Please specify PART number and chassis model number when ordering replacements.

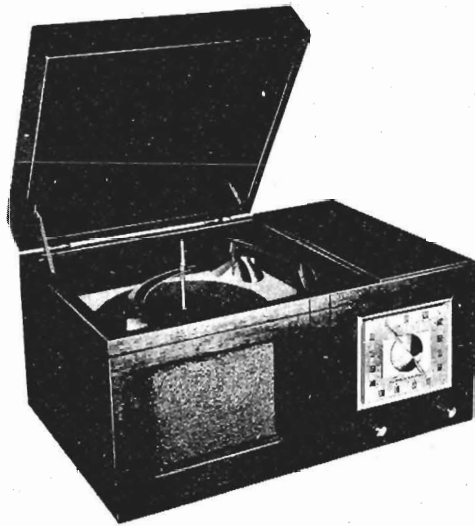

GENERAL DESCRIPTION

Your new radio-phonograph is a 5 tube (including rectifier tube) AC receiver and 3-speed automatic record changer housed in a beautiful mahogany wood cabinet. Controls are provided on the front for selecting radio or phonograph operation, for tuning and volume. Controls are provided on the phonograph for selecting speed and operation of the record changer (for details see instruction card placed on record changer turntable).

Special features of the radio receiver include a built-in loop antenna, automatic volume control, beam power output tube, and a permanent magnet dynamic speaker. Provision has been made for connection of an external antenna. It is designed for reception of radio stations in the standard broadcast band between 540 and 1600 kilocycles.

The Automatic Record Changer is designed to play standard 78 RPM, fine groove 45 RPM, or long play 33 1/3 RPM records of standard commercial dimensions. The playing capacity at a single loading is ten 12" records either standard or long play, twelve 10" records either standard or long play, or any mixture of ten 10" or 12" records of the same type. The changer can also accommodate a full stack of twelve 7" long play (33 1/3 RPM) or twelve 7" fine groove (45 RPM) records.

ELECTRICAL SPECIFICATIONS

- POWER SUPPLY:**
117 volts A.C. 60 cycles.
- FREQUENCY RANGE**
Broadcast 540-1600 Kc.
- INTERMEDIATE FREQUENCY:**
455Kc.
- ANTENNA:**
High impedance loop.
- TUNING:**
2 section, solid mounted gang condenser.
- SPEAKER:**
5 inch PM Dynamic.
- POWER CONSUMPTION:**
60 watts
- POWER OUTPUT:**
Undistorted—.8 watts
Maximum — 1 watt
- SENSITIVITY**—(Measured with signal injection at external antenna terminal and for 50 milliwatt output):
50 microvolts average
- SELECTIVITY:**
51 Kc. broad at 1000 times signal, measured at 1000 Kc.
- TUBE COMPLEMENT AND FUNCTION:**
 - 1 12BE6 Converter
 - 1 12BA6 I.F. Amplifier
 - 1 12AT6 Detector—A.V.C.—Audio Amplifier
 - 1 50C5 Audio Output
 - 1 35W4 Rectifier

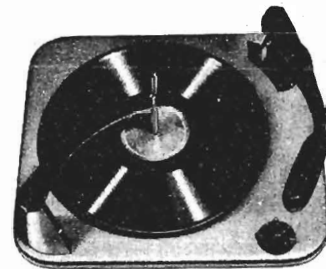

RECORD CHANGER

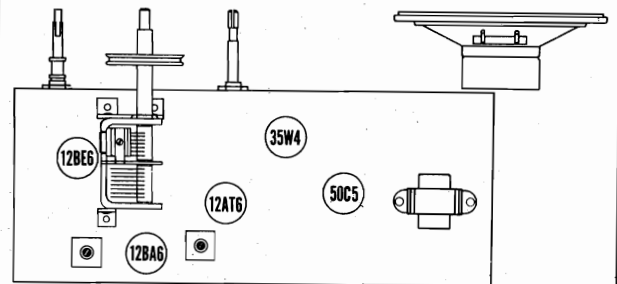

TUBE LOCATIONS

MODEL 15RA37-43-9230A

ALIGNMENT PROCEDURE

1. During the alignment of this receiver, the Pointer will have to be set to a specific frequency. Since the dial scale is mounted on the front of the cabinet, and the fact that the mass of the record changer may have an effect in the calibration, adjustment of the oscillator and antenna trimmers should be performed with the chassis mounted in the cabinet.
2. To remove the chassis, for I. F. Alignment, proceed as follows: Take off cabinet back by removing screws around edges and disconnecting the two antenna leads from the chassis. Next, take off knobs and pointer by grasping firmly and pulling forward. Now, take out the two chassis mounting screws at bottom of cabinet. Chassis can be withdrawn from cabinet.
3. Connect an output meter across the speaker voice coil.
4. For I. F. alignment only, connect ground lead of signal generator to B— lug (see voltage chart for convenient B— connection).

CAUTION: If your signal generator is designed with an AC-DC power supply, connect the ground lead to B— through a .25 Mfd. condenser.

5. Since the oscillator and antenna alignment is performed with the chassis in the cabinet, it will be necessary to couple the signal generator to the receiver by connecting its output to several turns of wire formed in a circular shape so that it may be placed adjacent and parallel to the receiver loop antenna.
6. With the gang condenser fully meshed, (Tuning control turned to a fully counter-clockwise position) the dial pointer should be in a horizontal position at low end of dial, parallel to the bottom edge of dial scale. If it is set incorrectly, merely hold tuning control shaft steady and move pointer to correct position.
7. Set volume control at maximum volume position and use a weak signal from the signal generator.

RANGE	SIGNAL GENERATOR		DUMMY ANTENNA	GANG CONDENSER SETTING	ADJUST SLUGS OR TRIMMERS
	FREQUENCY SETTING	CONNECTION AT RADIO			
I.F. 455 KC	455 KC	High side to trimmer No. 5. Ground lead as in step 4 above.	.02 Mfd. Condenser	Any point where it does not affect the signal.	(2nd I.F.) #1 & #2 for maximum output
	455 KC	High side to trimmer No. 5. Ground lead as in step 4 above.	.02 Mfd. Condenser	Any point where it does not affect the signal.	(1st I.F.) #3 & #4 for maximum output
Reinstall chassis in cabinet, replace pointer and mounting screws for chassis and loop.					
BROADCAST 540—1600 KC	1500 KC	Connect directly to coupling turn as described in step 5 above.	NONE	1500 KC	(Oscillator) Trimmer #5 for maximum output
	1500 KC	Connect directly to coupling turn as described in step 5 above.	NONE	Tune to 1500 KC generator signal	(Antenna) Trimmer #6 for maximum output

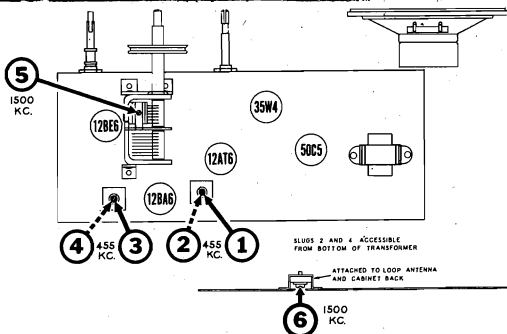

DIAL CORD ARRANGEMENT

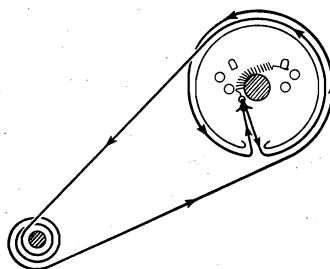

To string dial cord, turn the main drive drum to maximum counter-clockwise position and use following parts:
 114955 Clip on end of cord
 117057 Cord (2 feet)
 505161 Tension Spring
 To reinstall pointer on gang condenser shaft, see paragraph 6 in introduction to Alignment Procedure.

SOCKET VOLTAGES

1. All measurements made with a voltmeter having a sensitivity of 20,000 ohms per volt except where indicated by (*). The (*) symbol designates a vacuum tube voltmeter measurement.
2. Terminals on loop antenna are shorted together to minimize noise signal pickup.
3. Dial tuned to 540 Kc.
4. Volume control set to maximum with no signal.

NOTE A: The center stud of this tube must be connected to B- to reduce capacity coupling between pins. Oscillation may result if this connection is omitted.

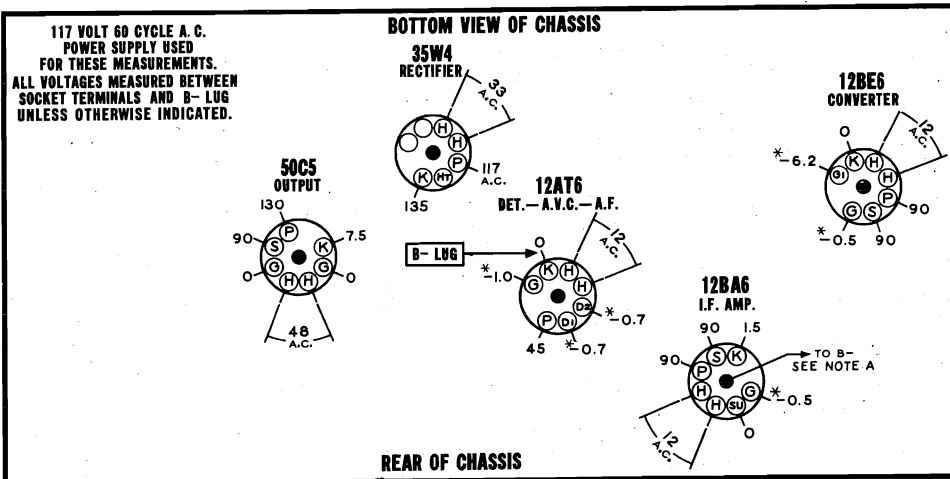

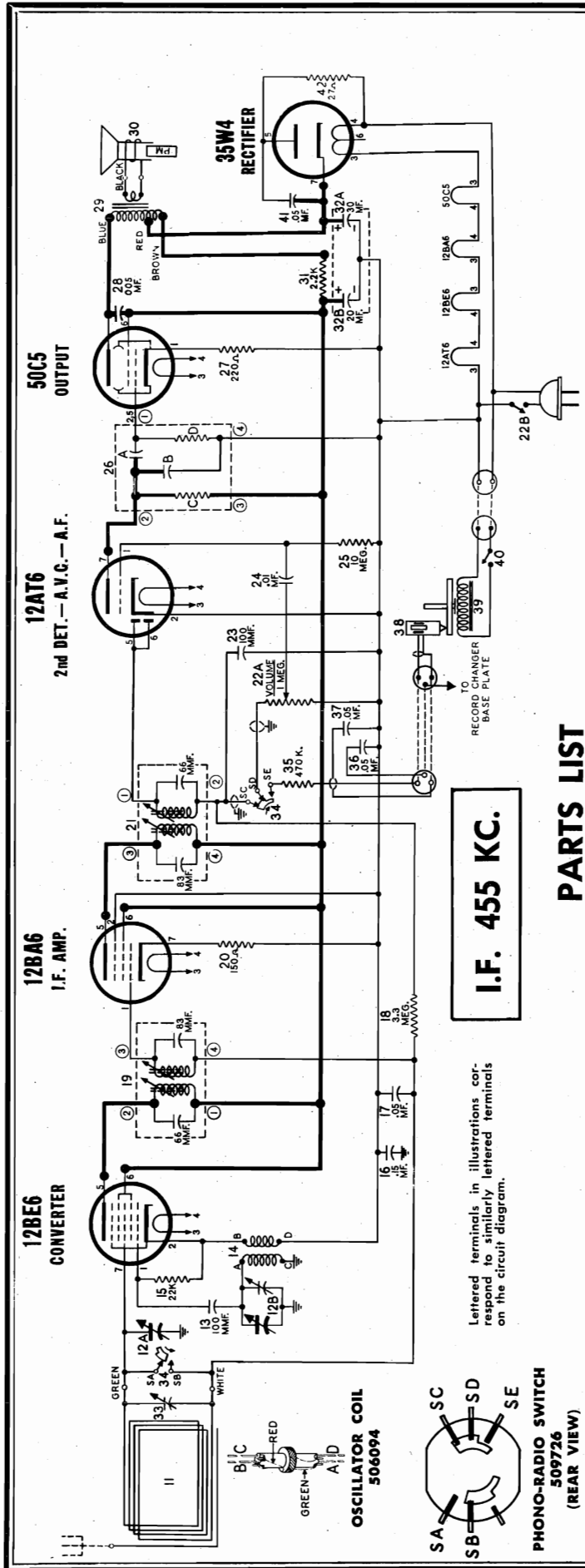

PARTS LIST

DIA. GRAM NO.	DESCRIPTION	PART NO.	DIA. GRAM NO.	DESCRIPTION	PART NO.
27	Resistor—carbon 220 Ohms 1/2 watt	510125	30	Speaker—P.M. dynamic (5")	509726
31	Resistor—carbon 2,200 Ohms 1 watt	510243	34	Switch—phono-radio	509726
35	Resistor—carbon 470,000 Ohms 1/2 watt	510185	38	Crystal cartridge	509820
42	Resistor—carbon 27 Ohms ± 10% 1/2 watt	510108	39	Motor—115 volt 60 cyc.	509301
COILS & TRANSFORMERS					
11	Loop Antenna (includes Condenser 33)	509747	40	Switch—OFF-ON on record changer	509205
14	Coil—oscillator	506094			
19	Transformer—1st I.F.	505867			
21	Transformer—2nd I.F.	505867			
29	Transformer—output	509739			
OTHER ELECTRICAL PARTS					
Audio coupling unit					
A—Condenser—ceramic .005 Mfd.					
B—Condenser—ceramic 250 Mmfd.					
C—Resistor—carbon 470,000 Ohms					
D—Resistor—carbon 470,000 Ohms					
E—Resistor—carbon 470,000 Ohms					
F—Resistor—carbon 470,000 Ohms					
G—Resistor—carbon 470,000 Ohms					
H—Resistor—carbon 470,000 Ohms					
I—Resistor—carbon 470,000 Ohms					
J—Resistor—carbon 470,000 Ohms					
K—Resistor—carbon 470,000 Ohms					
L—Resistor—carbon 470,000 Ohms					
M—Resistor—carbon 470,000 Ohms					
N—Resistor—carbon 470,000 Ohms					
O—Resistor—carbon 470,000 Ohms					
P—Resistor—carbon 470,000 Ohms					
Q—Resistor—carbon 470,000 Ohms					
R—Resistor—carbon 470,000 Ohms					
S—Resistor—carbon 470,000 Ohms					
T—Resistor—carbon 470,000 Ohms					
U—Resistor—carbon 470,000 Ohms					
V—Resistor—carbon 470,000 Ohms					
W—Resistor—carbon 470,000 Ohms					
X—Resistor—carbon 470,000 Ohms					
Y—Resistor—carbon 470,000 Ohms					
Z—Resistor—carbon 470,000 Ohms					
CONDENSERS					
12-A, B	Condenser—variable gang	509727			
13	Condenser—mica 100 Mmfd. 500 volt	512503			
16	Condenser—.15 Mfd. 400 volt	512040			
17	Condenser—.05 Mfd. 400 volt	512028			
23	Condenser—mica 100 Mmfd. 500 volt	512503			
24	Condenser—.01 Mfd. 400 volt	512010			
26-A	Condenser—ceramic .005 Mfd. 450 volt (Part of Audio Coupling Unit)	505858			
26-B	Condenser—ceramic 250 Mmfd. 450 volt (Part of Audio Coupling Unit)	505858			
28	Condenser—.005 Mfd. 500 volt	512006			
32-A, B	Condenser—electrolytic A—30 Mfd. 150 V. B—20 Mfd. 150 V.	508147			
33	Condenser—trimmer, 3-35 Mmfd.	509899			
36, 37	Condenser—.05 Mfd. 400 volt	512028			
41	Condenser—.05 Mfd. 600 volt	512030			
RESISTORS					
15	Resistor—carbon 22,000 Ohms 1/2 watt	510161			
18	Resistor—carbon 3.3 Meg. 1/2 watt	510194			
20	Resistor—carbon 150 Ohms 1/2 watt	510122			
22-A, B	Volume Control 1 Meg. (with OFF-ON switch)	509436			
25	Resistor—carbon 10 Meg. 1/2 watt	510197			
26-C, D	Resistor—carbon 470,000 Ohms 1/5 watt (Part of Audio Coupling Unit)	505858			
MISCELLANEOUS					
Cabinet					
Cord—dial drive (2 ft. required).....per ft.					
Clip for mounting I.F. transformer..... 505101					
Clip—Retainer on end of dial cord..... 114955					
Clip—Retains escutcheon..... 160832					
Clip—Retains tuning sleeve..... 506431					
Dial scale..... 509744					
Hinge for lid.....per pair					
Inserts for 45 R.P.M. records.....pkg. of 12 508553					
Knob—"OFF-VOL-ON"..... 509745					
Knob—"PHONO-RADIO"..... 509746					
Knob—tuning..... 508476					
Lid for cabinet..... 509721					
Lid support..... 509820					
Needle..... 509897					
Nut, locking; for needle..... 509898					
Plug—(2 pin) for phono. motor A.C. power 501031					
Plug—(3 pin) for phono. pick-up cable 508878					
Pointer changer..... 509743					
Record changer..... 509743					
Screw—8 x 7/8" chassis mounting..... 18785					
Sleeve—tuning..... 509723					
Spring—dial cord tension..... 505161					
Socket—miniature (7 pin)..... 507364					
Socket—(2 pin) for phono. motor cable..... 501182					
Socket—(3 pin) phono. pick-up cable..... 508879					

MODELS 15RA33-43-8245A,
15RA33-43-8246A

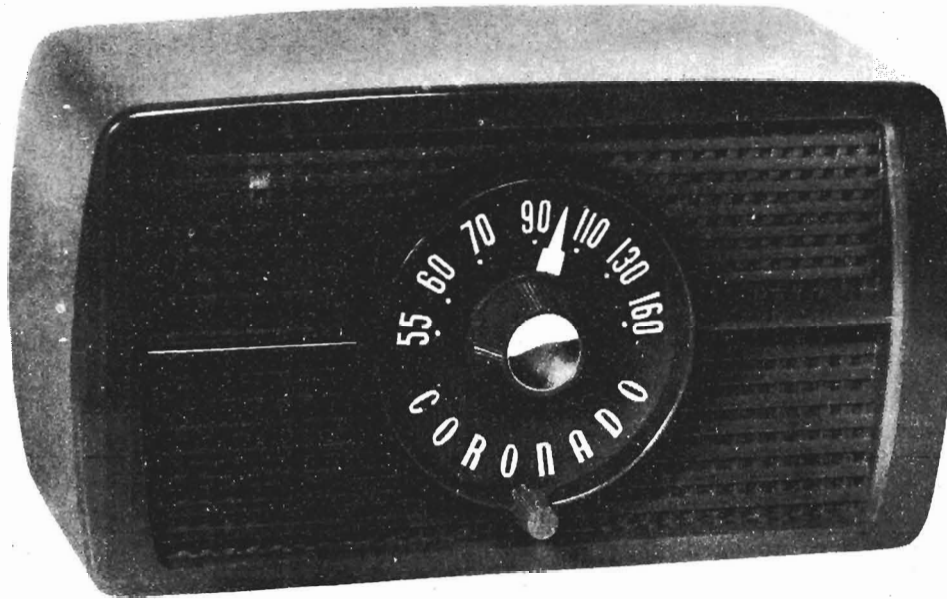

G S 604

SPECIFICATIONS

Power Supply	117 volts 60 cycle AC, 117 volts DC, 29 watts
Frequency Range	535 KC to 1630 KC
Intermediate Frequency	455KC
Antenna	Built-in Loop
Tuning	Variable Capacity
Speaker	4", P.M. voice coil impedance 3.2 ohms
Power Output	0.8 watt undistorted, 1.8 watts maximum
Sensitivity	400 uv/m average for 50 milliwatts output
Selectivity	55 KC broad at 1000 times, signal at 1000KC

Tubes used are as follows:

12BE6 Oscillator-Converter	50C5 Power Output
12AV6 or 12AT6 AVC, Detector, and Audio	35W4 Power Rectifier
12BA6 I.F. Amplifier	

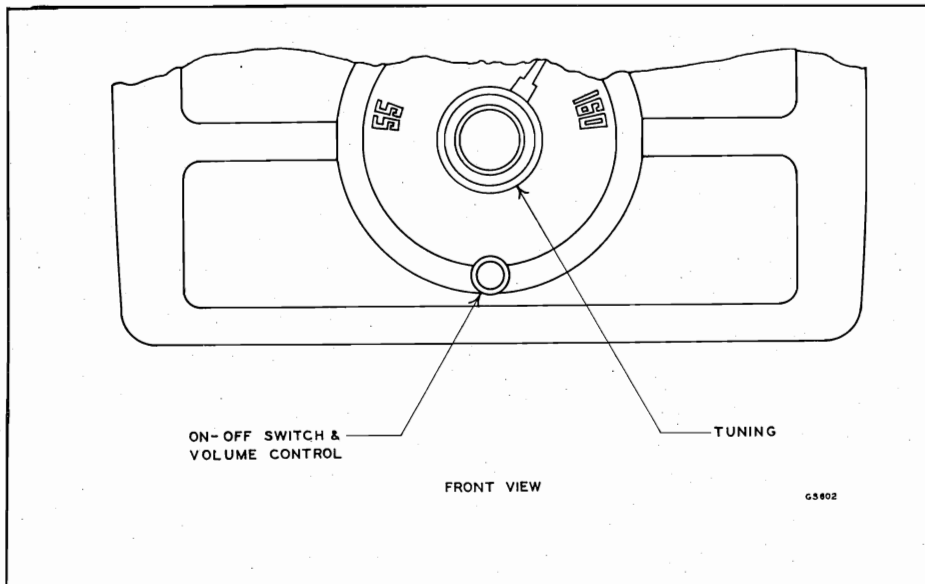

G S 602

MODELS 15RA33-43-8245A,
15RA33-43-8246A

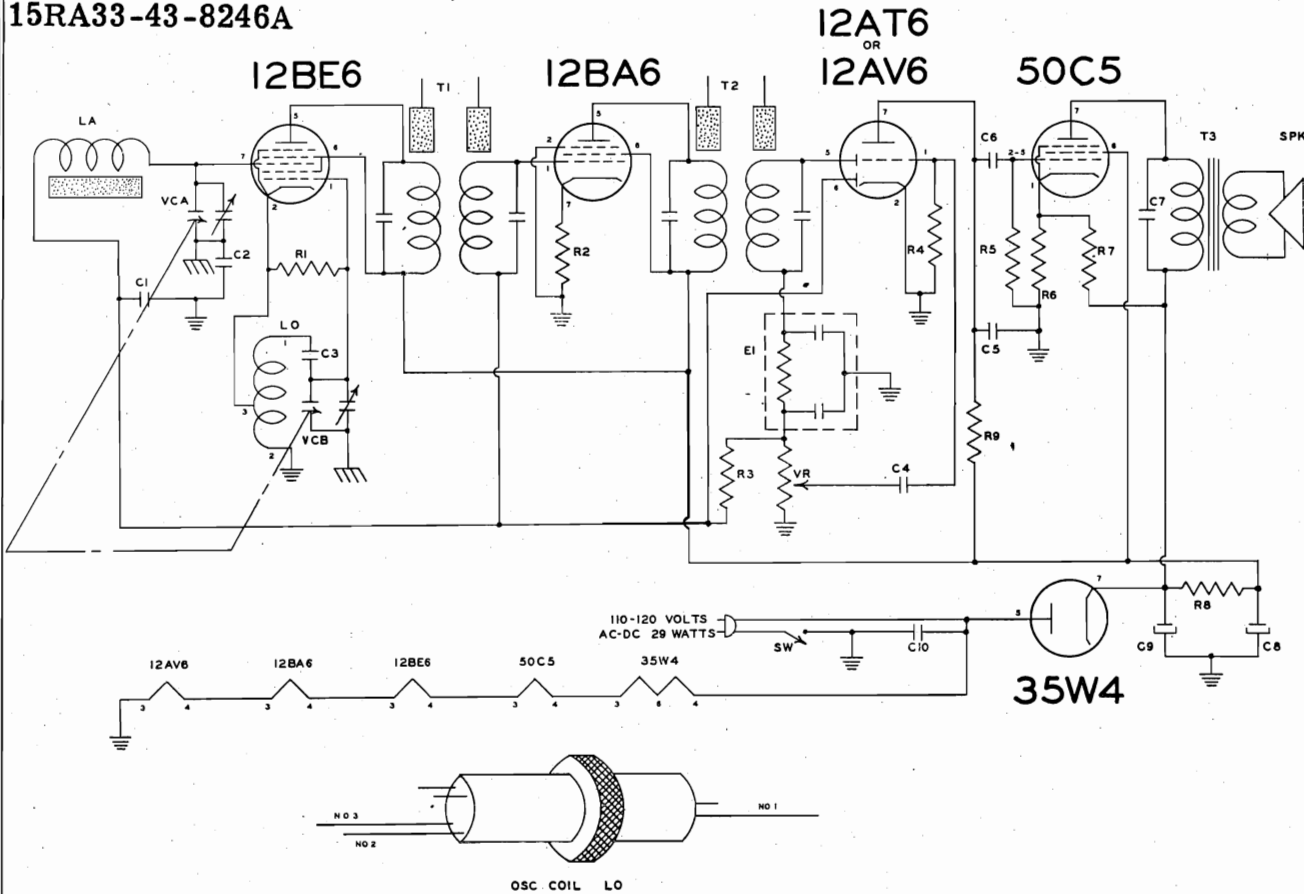

PARTS VALUES FOR T68 GAMBLE'S AC/DC CADET

CIRCUIT COMPONENTS

SYMBOL	PART NO.	DESCRIPTION	VALUE	RATING
VCA-VCB	VCT68	Condenser, 2 gang		
C1	CO52	Condenser, paper	.05 MFD	200 volts
C2	C12	Condenser, paper	.1 MFD	200 volts
C3	CO26	Condenser, paper	.02 MFD	600 volts
C4-C6-C7	CO056	Condenser, paper	.005 MFD	600 volts
C5	C2505M	Condenser, mica	250 MMFD	500 volts
C8	C40-20-1.5	Condenser, electrolytic	20 MFD	150 volts
C9	C40-20-1.5	Condenser, electrolytic	40 MFD	150 volts
C10	CO54	Condenser, paper	.05 MFD	400 volts
R1	R223.5	Resistor	22K ohm	1/2 watt
R2	R391.5	Resistor	390 ohm	1/2 watt
R3	R105.5	Resistor	1 megohm	1/2 watt
R4	R106.5	Resistor	10 megohm	1/2 watt
R5-R9	R474.5	Resistor	470K ohm	1/2 watt
R6	R121.5	Resistor	120 ohm	1/2 watt
R7	R1032	Resistor	10K ohm	2 watt
R8	R1021	Resistor	1000 ohm	1 watt
E1	CR1	Diode filter unit	2X100 MMFD-47K ohm	
VR	VRT67G	Volume control	1 megohm	
LA	LAT68A	Antenna rod & back		
LO	LOT67	Oscillator coil		
T1-T2	TI11-31-A	I.F. transformer		
T3	E-81645-T	Output transformer		
SW	VRT67G	Switch S.P.S.T. on volume control		
SPK	SPKT67	4" P.M. speaker		

MECHANICAL PARTS

PART NO.	DESCRIPTION	PART NO.	DESCRIPTION	PART NO.	DESCRIPTION
M-1801	Chassis	H-1805	Ground lug	P-1704AR	Pointer knob, red
M-1802	Chassis cover	H-81644-6	Miniature tube socket	P-1704AI	Pointer knob, ivory
H-1601	Trimount 5/8"	W-1802	Line cord and plug	P-1704R	Round knob, red
H-1802	Trimount 1/4"	SR-3P	Strain relief	P-1704I	Round knob, ivory
TI11-31-B	I.F. mounting clip	P-1801R	Cabinet, red	M1807	Dial pointer
		P-1801IG	Cabinet, ivory, green dial		

FOR PRICES SEE CORRESPONDING KEY NO: IN PRICE LIST

MODEL 15RA33-43-8635,
Westerner



G S 701

SPECIFICATIONS

Power Supply	117 volts A. C., 60 cycle only, 45 watts
Frequency Range	540 KC to 1630 KC
Intermediate Frequency	455 KC
Antenna	FERRI-ROD LOOP
Tuning	Variable Capacity
Speaker	5" x 7" P.M., voice coil impedance 3.2 ohms
Power Output	4 watts undistorted, 4.5 watts maximum
Sensitivity	200 uv/m for 500 milliwatts output
Selectivity	40 KC broad at 1000 times, signal at 1000 KC

Tubes used are as follows:

6BA6 R.F. Amplifier	6AV6 AVC, Detector, and Audio
6BE6 Oscillator-Converter	6V6GT Power Output
6BA6 I.F. Amplifier	6X4 Power Rectifier

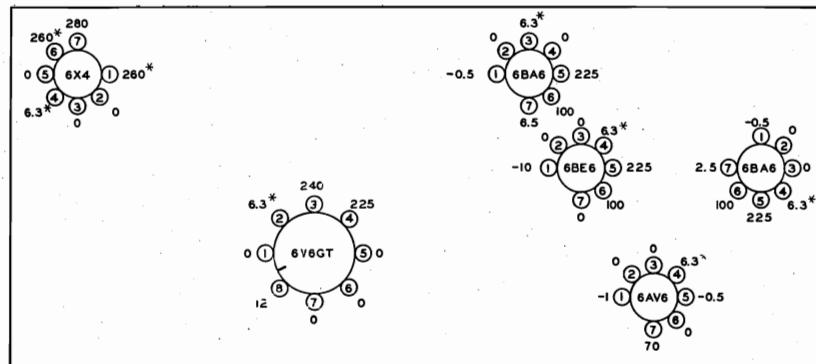

FRONT

BOTTOM VIEW

* INDICATES A C
ALL VOLTAGES IN REFERENCE
TO COMMON GROUND
ALL VOLTAGE READINGS TAKEN
WITH VTVM

VOLTAGE CHART

G3704

332

OPERATION

Caution: This set is for use on 117 volt A.C. 60 cycle only. To operate radio, be sure Radio-Phono switch on the back of the set is switched to side marked RADIO. Turn on radio with small outer left-hand knob and allow set to warm up for approximately one minute. Tune in desired station with right-hand knob, adjust volume to desired level with small outer left-hand knob, and select most pleasing tone with large inner left-hand knob.

To operate phonograph: Plug phono lead from phono turn table into receptacle on the back of the radio marked PHONO. Set Radio-Phono switch on the back of the radio to side marked PHONO. Switch radio set on with small outer left-hand knob, and allow set to warm up for approximately one minute. Start record player, and adjust volume to desired level with small outer left-hand knob and select most pleasing tone with large inner left-hand knob.

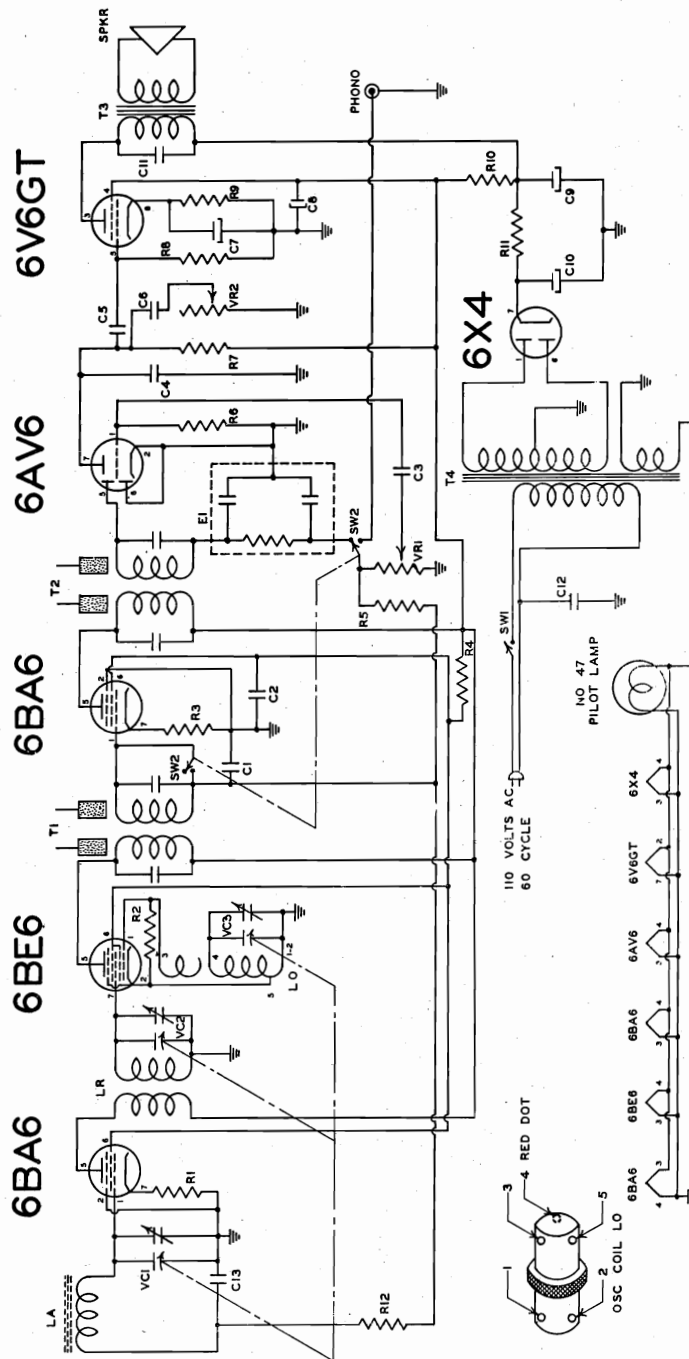

63762

MODEL 15RA33-43-8635, Westerner

ALIGNMENT PROCEDURE

The following procedure is for use only by competent servicemen having the proper equipment. The alignment should be made with volume control fully on, and with the output from the signal generator as low as possible, to prevent AVC action from interfering with proper alignment.

With the output meter connected across the voice coil of the speaker, and the signal generator modulated at 400 c.p.s., adjust all trimmers for maximum output using the alignment procedure given below:

SIGNAL GENERATOR	POSITION OF TUNING CONDENSER	ADJUST FOR MAXIMUM OUTPUT
Frequency		
455 KC	Connection to Radio	T1 & T2
1630 KC	VC2 stator section	OSC
1400 KC	VC2 stator section	Trimmer
	Radiation Loop	R.F. & ANT. Trimmers
	None	
		Tune in Sig. Gen.

Connect low side of signal generator to common negative.

PARTS VALUES FOR WESTERNER 15RA33-43-8365

SYMBOL	PART NO.	DESCRIPTION	VALUE	RATING	CIRCUIT COMPONENTS	POSITION OF TUNING CONDENSER	ADJUST FOR MAXIMUM OUTPUT
VC1,2,3, C1, C13	VCT69	Condenser, 3 gang			R5, R12		
C2	CO52	Condenser, paper	.05 MFD	200 volts	R6		
C3, C6, C11	CO54	Condenser, paper	.05 MFD	400 volts	R7, R8		
C4	CO056	Condenser, paper	.005 MFD	600 volts	R9		
C5	C2505M	Condenser, mica	250 MMFD	500 volts	R10		
C7	CO26	Condenser, paper	.02 MFD	600 volts	R11		
C8	C20-T69	Condenser, electrolytic	20 MFD	25 volts	VR1	Fully open	T1 & T2
C9	C20-T69	Condenser, electrolytic	20 MFD	350 volts	VR2	Fully open	OSC
C10	C20-T69	Condenser, electrolytic	20 MFD	350 volts	E1		Trimmer
C12	CO476M	Condenser, electrolytic plastic case	.047 MFD	600 volts	LA		R.F. & ANT. Trimmers
R1	R182.5	Resistor	1800 ohm	1/2 watt	LR		
R2	R223.5	Resistor	22 K ohm	1/2 watt	LO		
R3	R391.5	Resistor	390 ohm	1/2 watt	TI-T2		
R4	R1232	Resistor	12 K ohm	2 watt	T3		
					T4		
					SW1		
					SW2		
					SPKR		
					R106.5		
					R474.5		
					R3311		
					R1021		
					R4711		
					VRT69		
					VRT69		
					CR1		
					LAT69		
					LRT69		
					T64LO		
					TI11-31-A		
					L3595		
					XL-60		
					VRT69		
					SS-3		
					SPKT69		
					R105.5		
					R106.5		
					R474.5		
					R3311		
					R1021		
					R4711		
					VRT69		
					VRT69		
					CR1		
					LAT69		
					LRT69		
					T64LO		
					TI11-31-A		
					L3595		
					XL-60		
					VRT69		
					SS-3		
					SPKT69		
					R105.5		
					R106.5		
					R474.5		
					R3311		
					R1021		
					R4711		
					VRT69		
					VRT69		
					CR1		
					LAT69		
					LRT69		
					T64LO		
					TI11-31-A		
					L3595		
					XL-60		
					VRT69		
					SS-3		
					SPKT69		
					R105.5		
					R106.5		
					R474.5		
					R3311		
					R1021		
					R4711		
					VRT69		
					VRT69		
					CR1		
					LAT69		
					LRT69		
					T64LO		
					TI11-31-A		
					L3595		
					XL-60		
					VRT69		
					SS-3		
					SPKT69		
					R105.5		
					R106.5		
					R474.5		
					R3311		
					R1021		
					R4711		
					VRT69		
					VRT69		
					CR1		
					LAT69		
					LRT69		
					T64LO		
					TI11-31-A		
					L3595		
					XL-60		
					VRT69		
					SS-3		
					SPKT69		
					R105.5		
					R106.5		
					R474.5		
					R3311		
					R1021		
					R4711		
					VRT69		
					VRT69		
					CR1		
					LAT69		
					LRT69		
					T64LO		
					TI11-31-A		
					L3595		
					XL-60		
					VRT69		
					SS-3		
					SPKT69		
					R105.5		
					R106.5		
					R474.5		
					R3311		
					R1021		
					R4711		
					VRT69		
					VRT69		
					CR1		
					LAT69		
					LRT69		
					T64LO		
					TI11-31-A		
					L3595		
					XL-60		
					VRT69		
					SS-3		
					SPKT69		
					R105.5		
					R106.5		
					R474.5		
					R3311		
					R1021		
					R4711		
					VRT69		
					VRT69		
					CR1		
					LAT69		
					LRT69		
					T64LO		
					TI11-31-A		
					L3595		
					XL-60		
					VRT69		
					SS-3		
					SPKT69		
					R105.5		
					R106.5		
					R474.5		
					R3311		
					R1021		
					R4711		
					VRT69		
					VRT69		
					CR1		
					LAT69		
					LRT69		
					T64LO		
					TI11-31-A		
					L3595		
					XL-60		
					VRT69		
					SS-3		
					SPKT69		
					R105.5		
					R106.5		
					R474.5		
					R3311		
					R1021		
					R4711		
					VRT69		
					VRT69		
					CR1		
					LAT69		
					LRT69		
					T64LO		
					TI11-31-A		
					L3595		
					XL-60		
					VRT69		
					SS-3		
					SPKT69		
					R105.5		
					R106.5		
					R474.5		
					R3311		
					R1021		
					R4711		
					VRT69		
					VRT69		
					CR1		
					LAT69		
					LRT69		
					T64LO		
					TI11-31-A		
					L3595		
					XL-60		
					VRT69		
					SS-3		
					SPKT69		
					R105.5		
					R106.5		

MODEL 15RA33-43-
8635, Westerner

MECHANICAL PARTS

PART NO.	DESCRIPTION	PART NO.	DESCRIPTION	PART NO.	DESCRIPTION
M-1901	Chassis	P-1903	Knob, round insert, walnut	H-81641-29	#29 terminal board
M-1902	Bracket, dial	H-81644-9	Pilot light socket	H-1903	Shaft, tuning
T111-31-B	I.F. mounting clip	H-81644-6	Miniature tube socket	H-1902	Bushing, tuning shaft
P-1904	Dial pointer	H-81644-5	Octal tube socket, wafer	H-1601	Trimount 5/8"
P-1906	Dial scale	H-81644-7	Phono socket	W-1802	Line cord and plug
H-1904	Dial spring	H-81641-3	#3 terminal board	SR-3P	Strain relief
P-1905	Escutcheon	H-81641-4	#4 terminal board	P-1908	Baffle, speaker
P-1902	Knob, round hub, walnut			M-1903	Angle bracket
				P-1901	Cabinet, walnut

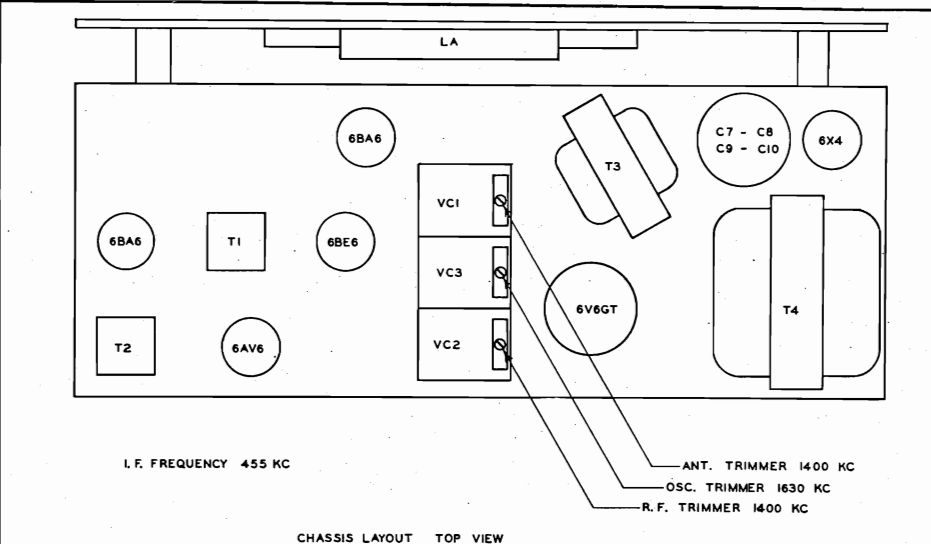
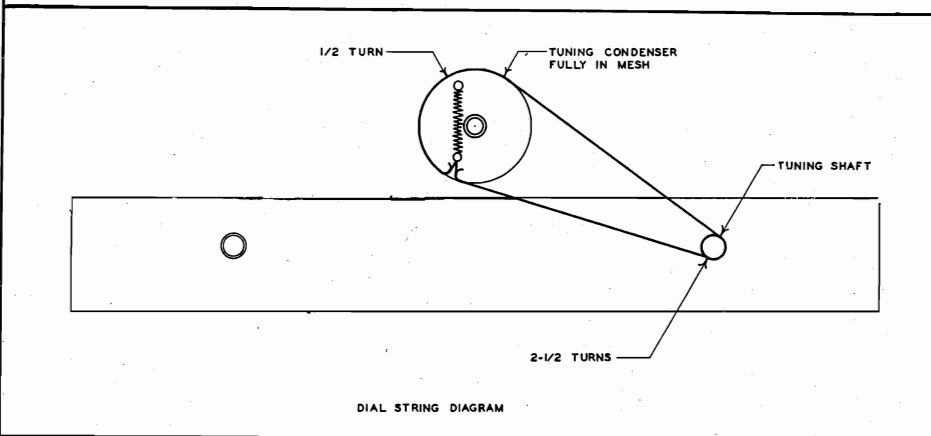
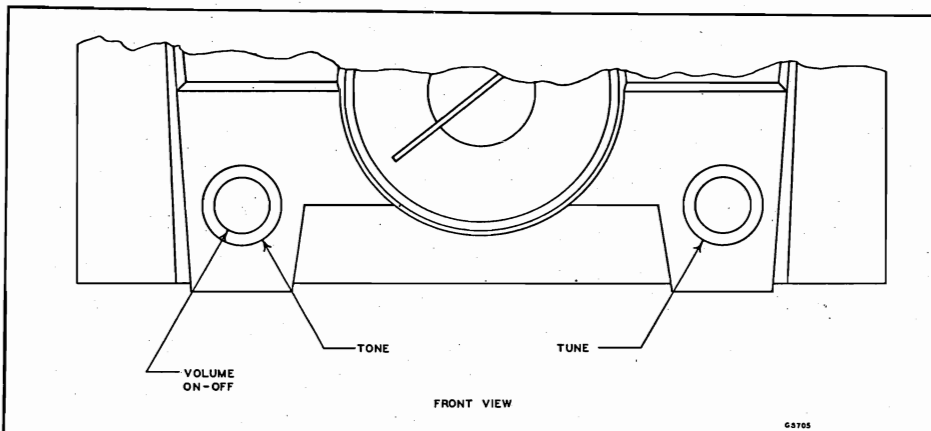

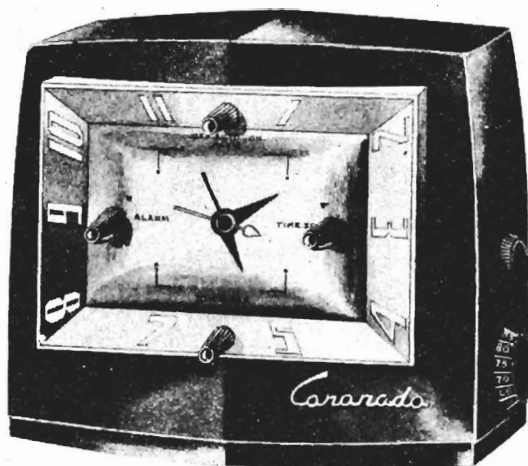

GENERAL DESCRIPTION

This Clock Radio is an AC operated five-tube radio (including rectifier tube). It employs a Sessions Electric Clock Movement for switching AC power to the radio at any pre-set time.

The "Radio" Switch removes power from the unit entirely when in the "OFF" position, connects power to the receiver in the "ON" position, and switches power to the receiver through the clock contacter position.

The "Sleep" Switch is a time operated device which closes the line to the receiver for the period for which the adjustment is made. The "Sleep" Switch is in parallel with the clock switch.

ALIGNMENT PROCEDURE

- OUTPUT METER ACROSS VOICE COIL
- VOLUME CONTROL MAXIMUM
- REDUCE INPUT AS NEEDED
- ALL GROUND CONNECTIONS TO B—

Frequency	Dummy Antenna	Connection to Radio	Position of Variable	Adjust for Maximum Output
455 KC	05	Pin 7 — 12BE6 Converter Grid	Rotor Open (Plates Out of Mesh)	T2 — Pri. and Sec.
455 KC	05	Pin 7 — 12BE6 Converter Grid	Rotor Open (Plates Out of Mesh)	T1 — Pri. and Sec.
1650 KC	05	Pin 7 — 12BE6 Converter Grid	Rotor Open (Plates Out of Mesh)	C7B — Osc. Trimmer
1500 KC		Several Turns Around Loop Ant.	1500 KC	C7A — Ant. Trimmer

REPEAT STEPS 3 and 4

ELECTRICAL SPECIFICATIONS

- Power Supply:—117 Volts AC, 60 Cycles.
- Frequency Range:—540-1650 Kilocycles.
- Intermediate Frequency:—455 Kilocycles.
- Antenna:—Air loop mounted on rear of chassis.
- Tuning:—Two gang, direct drive variable condenser.
- Speaker:—4-inch PM round, 3.2 ohm Voice Coil.
- Power Consumption:—32 watts.
- Power Output:—.85 watts undistorted, 1.25 watts maximum.
- Sensitivity:—50 Microvolts for 50 Milliwatt Output.
- Selectivity:—59 KC broad at 1000 times signal at 1000 KC.

TUBE COMPLIMENT

- 12BE6 — Converter
- 12AT6 — 2nd Detector, 1st Audio Amp. and AGC
- 12BA6 — I.F. Amplifier
- 50C5 — Audio Output
- 35W4 — Power Rectifier

(NOTE: Appliance outlet is rated for 1000 watts)

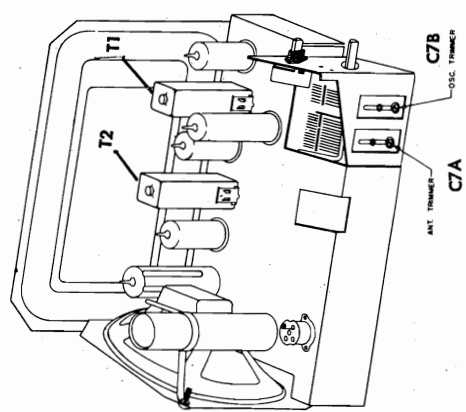
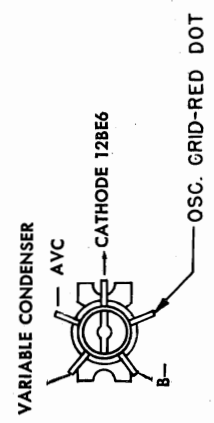
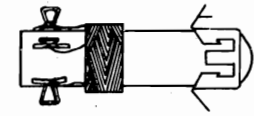
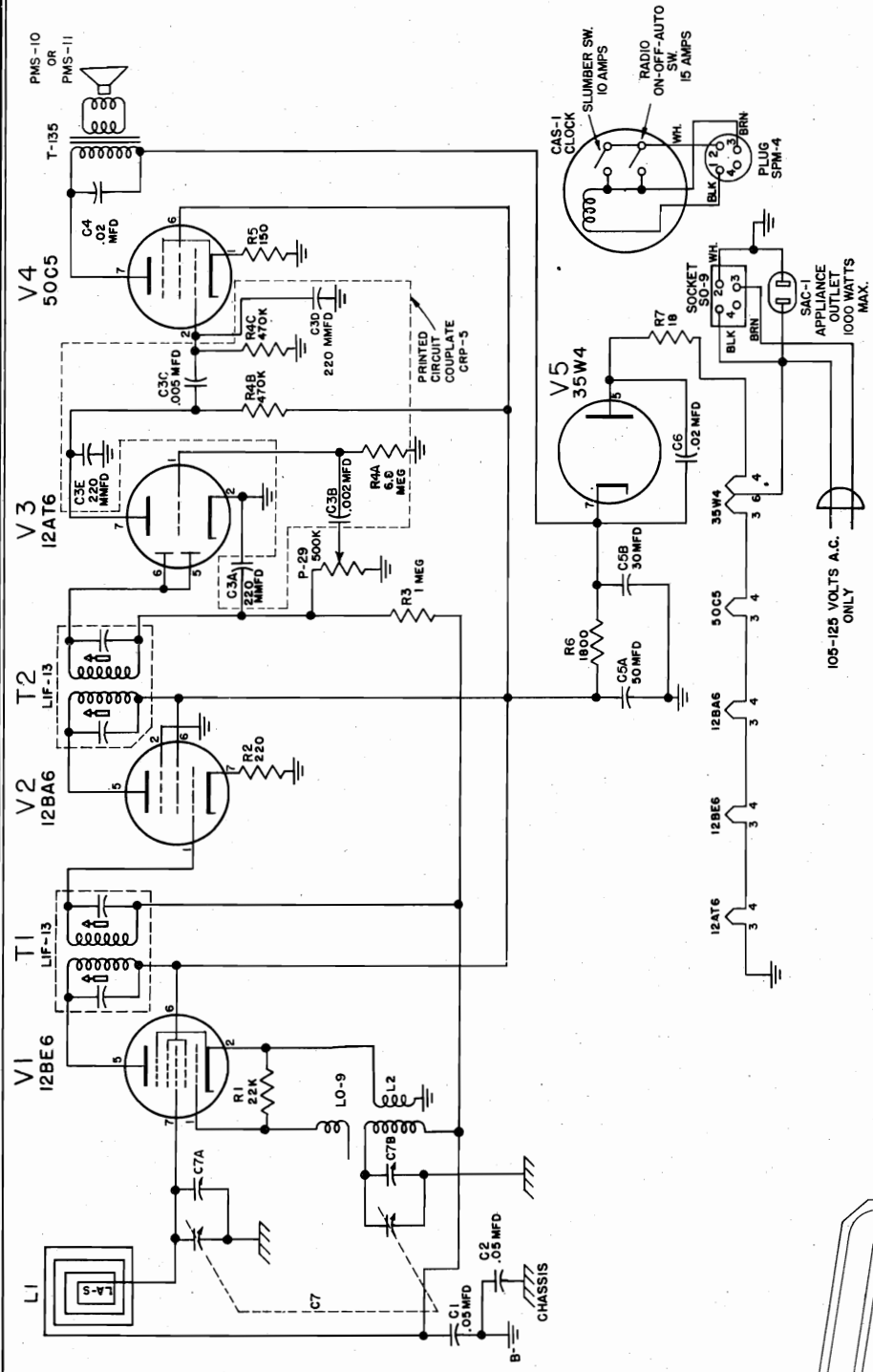

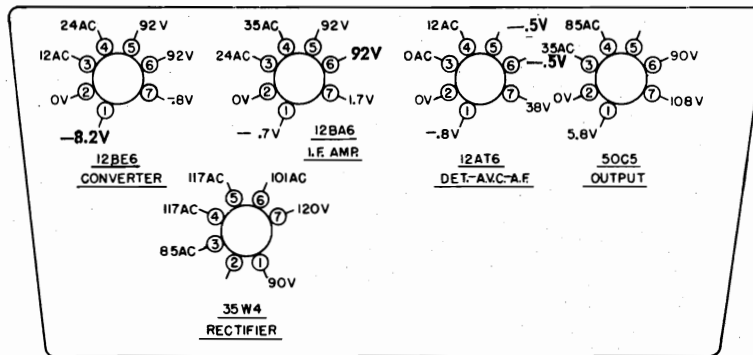

VOLTAGE READINGS TAKEN WITH VTVM FROM PINS DESIGNATED TO B—

Line Voltage — 117 volts A.C. Full Volume — No signal

PARTS LIST

Schematic Symbol No.	Description	Part No.	Schematic Symbol No.	Description	Part No.
R 1	22k Ohms 1/2 W. 10%—Carbon Resistor	RC-223-2	CV 8	2-Gang Variable Condenser	CV-8
R 2	220 Ohms 1/2 W. 10%—Carbon Resistor	RC-221-2	P 29	Potentiometer—Volume Control 1/2 Meg.	P-29
R 3	1 Meg Ohm 1/2 W. 10%—Carbon Resistor	RC-105-2	LO-9	Broadcast Oscillator Coil	LO-9
R 5	150 Ohms 1/2 W. 10%—Carbon Resistor	RC-151-2	T 135	Audio Output Transformer	T-135
R 6	1800 Ohms 1 W. 20%—Carbon Resistor	RC-182-4	T 1 & T 2	I.F. Transformer	LIF-13
R 7	18 Ohms 1/2 W. 10%—Carbon Resistor	RC-180-2	L 1	Antenna Loop	LA-9
C 1	.05 Mfd. 400 V. — Paper Capacitor	CP-4-15	V 1	Tube—12BE6—Oscillator and Mixer	12BE6
C 2	.05 Mfd. 200 V. — Paper Capacitor	CP-2-15	V 2	Tube—12BA6—I.F. Amplifier	12BA6
C 4	.02 Mfd. 400 V. — Paper Capacitor	CP-4-12	V 3	Tube—12AT6—Detector and 1st Audio Amplifier	12AT6
C5A & C5B	30-50 Mfd. 150 V. — Electrolytic Condenser with Mtg. Strap	CET-19	V 4	Tube—50C5—Power Amplifier	50C5
C 6	.02 Mfd. 600 V. — Paper Capacitor	CP-6-12	V 5	Tube—35W4—Rectifier	35W4

FOR PRICES SEE CORRESPONDING KEY NO. IN PRICE LIST

SERVICING OF SESSIONS MOVEMENT

The Sessions Electric Clock Movement used in this unit will be repaired at no charge within the warranty period in the event of failure due to defects in workmanship and material, provided the unit has been subject to normal use.

Service stations have been established that are qualified to repair these movements upon delivery to them. The entire clock assembly first must be removed, as these stations positively will not service any clocks that are still mounted on the radio unit.

SEE INSTRUCTIONS ON NEXT PAGE

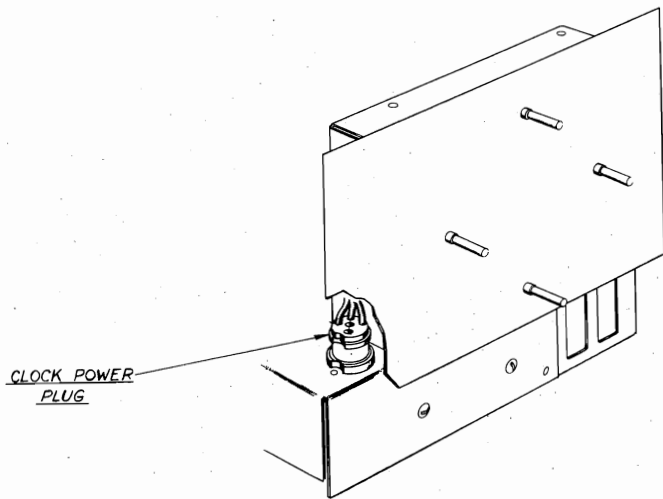

Figure 1

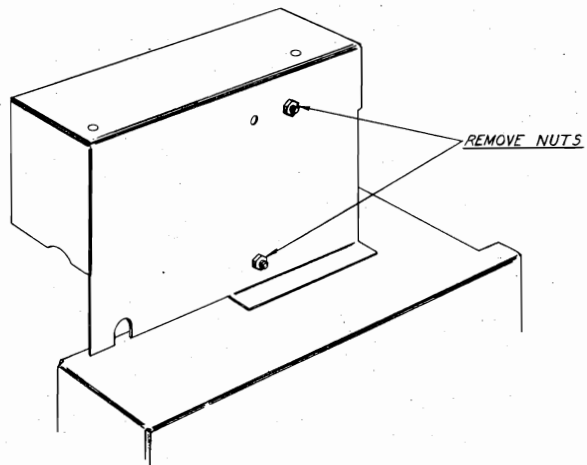

Figure 2

TO TAKE CLOCK MOVEMENT OUT OF CABINET PROCEED AS FOLLOWS:

Remove the following:

1. Line cord from AC receptacle.
2. Tuning and volume control knobs. Also the four small knobs on the clock setting controls.
3. Chassis from cabinet.
4. Clock power plug which fits into receptacle on top of chassis (Fig. 1).
5. Two nuts fastening clock to bracket (Fig. 2).

MISCELLANEOUS

Part No.	
PMS 10 or PMS 11	4" PM Speaker
KM 52	Tuning Knob
KM 53	Volume Control Knob
CV8	Two-Gang Variable Condenser

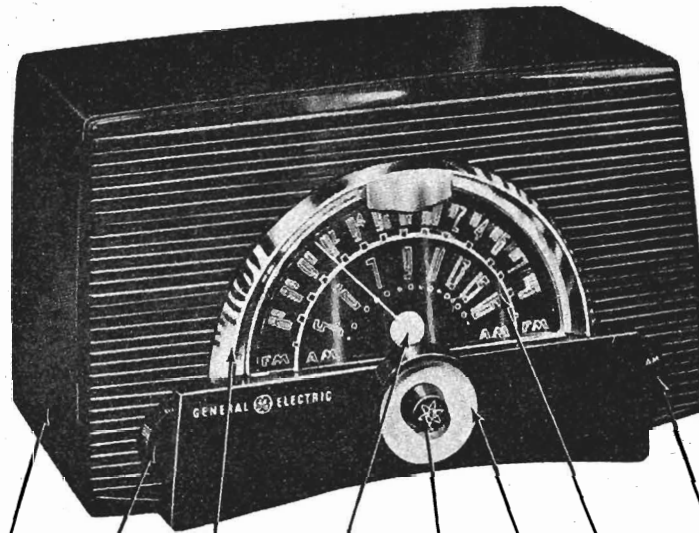

CABINET RAU-355 VOLUME RDK-211 ESCUTCHEON RDE-080 POINTER RDP-065 TONE RDK-266 TUNING RDK-265 DIAL RDS-111 BAND SWITCH RDK-267

SPECIFICATIONS

CABINET

Material	plastic
Color	mahogany
Height	8 ¹ / ₈ inches
Width	13 ¹ / ₂ inches
Depth	7 ³ / ₈ inches

ELECTRICAL

Voltage	105-125 AC or DC
Frequency on AC	50 to 60 cps
Wattage	40 watts

TUNING RANGE

AM	540-1600 kc
FM	88-108 mc

INTERMEDIATE FREQUENCIES

AM	455 kc
FM	10.7 mc

POWER OUTPUT

Undistorted	1.0 watt
-------------------	----------

LOUDSPEAKER

Type	permanent magnet
Size	5 ¹ / ₄ inches
Voice Coil Impedance at 400 cps	3.2 ohms

ANTENNA

AM	built-in loop
FM	power line antenna or 300 FM ant.

GENERAL

Model 409 is a table model receiver providing reception on the AM band (540 to 1600 kc) and the FM band (88-108 mc). The receiver is housed in a mahogany colored plastic cabinet.

The receiver has a built-in FM power-line antenna. To operate the receiver from the built-in FM power line antenna it is necessary to connect the power-line antenna wire to FM antenna terminal.

Note: To remove the dial scale it is necessary to remove the escutcheon to gain access to the dial scale mounting screws. Remove the escutcheon by pushing forward on the escutcheon mounting studs from inside of the cabinet.

TUBES

V1—R.F. Amplifier	6BJ6
V2—F.M. Converter—A.M.—F.M. Oscillator	12AT7
V3—1st F.M., I.F. Ampl.—A.M. Conv.	12AU6
V4—2nd F.M., 1st A.M.—I.F. Ampl.	12BA6
V5—F.M. Limiter	12AU6
V6—F.M. Discriminator, A.M. Detector and Audio Amp.	19T8
V7—Audio Output	35C5

VOLTAGE CHECKS

I. A.M.—I.F. Sensitivity

100 microvolts at 455 kc. 30% mod. with 400 cycles at the grid (pin 1) of V3 for ¹/₂ watt audio output.

A.M.—R.F. Sensitivity

100 microvolts per meter at 580 kc. 30% mod. with 400 cycles for ¹/₂ watt audio output.

75 microvolts per meter, at 975 kc. 30% mod. with 400 cycles for ¹/₂ watt audio output.

75 microvolts per meter at 1500 kc. 30% mod. with 400 cycles for ¹/₂ watt audio output.

2. The following voltages are required at the point of input designated to produce one volt d-c at the test point on the rear of the chassis. This test point is connected to the limiter grid (V5 pin 1) through a 470,000 ohm resistor. The one volt d-c can only be measured with a vacuum tube voltmeter.

F.M.—I.F. Sensitivities at 10.7 Mc Unmod.

(a) 50,000 microvolts at V4 grid (pin 1) for 1 volt d-c at the test point.

(b) 1,000 microvolts at V3 grid (pin 1) for 1 volt d-c at the test point.

(c) 100 microvolts at V2 grid (pin 7) for 1 volt d-c at test point.

Note pin 7 of V2 must be disconnected from the r-f tuner gang before attempting to measure the sensitivity at the converter grid (V2 pin 7).

F.M.—R.F. Sensitivity

For F.M.—R.F. alignment the input impedance of the signal generator should match the 300 ohm input impedance of the receiver.

25 microvolts at 88 megacycles for 1 volt d-c at the test point.

20 microvolts at 98 megacycles for 1 volt d-c at the test point.

30 microvolts at 108 megacycles for 1 volt d-c at the test point.

3. Audio Gain

0.1 volt at 400 cycles applied across the volume control with the volume control set at maximum should give approximately ¹/₂ watt output.

4. Oscillator Grid Bias

The d-c voltage developed across R2002 should be approximately 8 volts at 1000 kc and 3 volts at 98 megacycles as measured with a vacuum tube voltmeter.

5. Hum Measurement

On A.M. with the volume control set at a minimum, the hum measured across the speaker leads should not exceed 7 millivolts.

On F.M. with the limiter grid pin 1 of V5 connected to chassis through a 0.1 mf capacitor and the volume control set at a maximum, the hum should not exceed 15 millivolts measured across the speaker leads.

TO INDEX THE DIAL POINTER

The vertical mark on the front of the cabinet under the dial scale represents 98 mc on the F.M. scale. When the pointer is set to this point the receiver should be tuned to 98 mc on the F.M. band. At 98 mc the pointer should be vertical and equidistant from either end of its travel. The pointer will be horizontal at either end of its rotation.

Insert the chassis into the cabinet with the dial scale removed. Connect a 98 mc signal to the F.M. antenna terminals. With the band switch switched to F.M. tune the receiver to give maximum d-c output at the limiter grid test point on the rear of the chassis. Reduce the signal input so that the output at the limiter grid measures about 1 volt as measured by a vacuum tube voltmeter. Set the pointer onto the shaft opposite the 98 mc mark on the cabinet.

If a 98 mc sweep signal is used tune the gang condenser for maximum amplitude of the response curve, of Fig. A on the scope, at the limiter grid test point. Keep input low to prevent limiting which will cause the response curve to flatten off.

CAUTION

ALWAYS USE AN ISOLATION TRANSFORMER IN THE RECEIVER POWER LINE WHEN SERVICING OR ALIGNING THIS RECEIVER TO PROTECT TEST EQUIPMENT.

MODEL 409

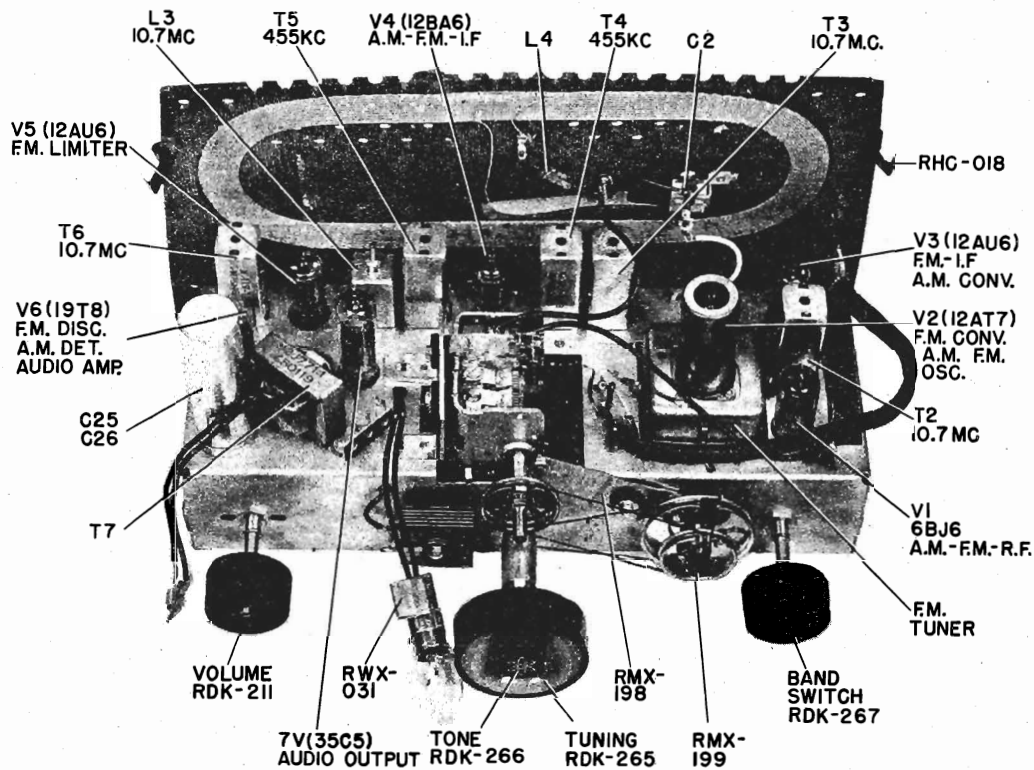

FIG. 1. TOP VIEW

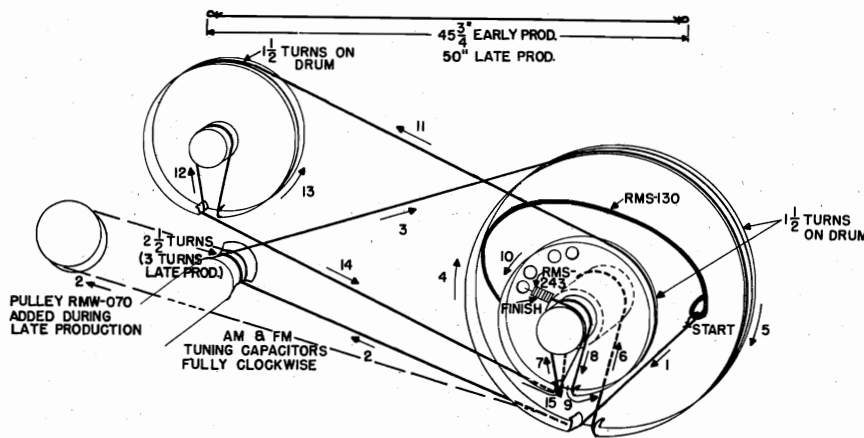

FIG. 2. DIAL STRINGING

DIAL STRINGING

The cord should be strung with both the AM and the FM drums in their full clockwise position. When the dial stringing is completed it may be necessary to slip the cord slightly around the AM drum to make sure that both the AM capacitor and the FM capacitor are fully open or fully closed at the same time.

Steps 1, 2, 3, 4, and 5 are on the large FM drum as shown. Step 6 takes the dial cord around the axle between the drums as shown. Step 7 the cord comes through the notch on the small FM drum and around the axle in front of the small FM drum. Steps 8, 9, and 10 go around the small FM drum. Steps 11, 12, and 13 go around the AM drum as shown. Step 15 the cord goes through the notch in the small FM drum around the axle in front of the small FM drum and connects to the tension spring as shown.

A.M. METER ALIGNMENT NOTES

1. Connect an output meter across the speaker leads to indicate maximum output during A.M. alignment.

2. Turn the volume control to maximum clockwise position and reduce signal input so that output meter does not indicate more than 1/2 watt output during A.M. alignment.

3. For alignment of the antenna trimmer C2 it is necessary to inductively couple the signal generator output to the loop antenna by connecting a four turn, six inch diameter loop of wire across the generator output terminals and locating the loop about one foot from the radio loop. The position of loop should not be changed during alignment to prevent possible errors in peak readings.

4. Set the band switch in A.M. position.

F.M. METER ALIGNMENT NOTES

5. Connect a vacuum tube voltmeter between the test point on the rear of the chassis and chassis to read the d-c voltage developed at the limiter grid during F.M.-I.F. and R.F. alignment. Dress the V.T.V.M. leads away from the r-f end of the

chassis to prevent regeneration. Reduce the signal input so that the V.T.V.M. reads approximately 1 volt d-c.

6. Connect a vacuum tube voltmeter across the volume control to read the discriminator output.

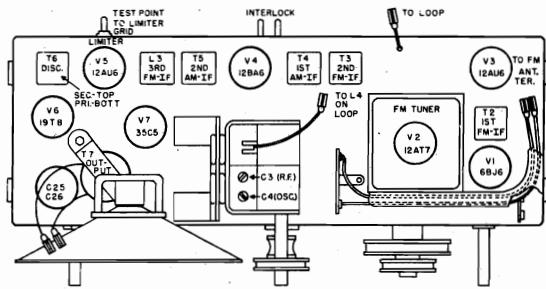

Fig. 3. TOP VIEW

7. To align the primary of T6 (discriminator) detune the signal generator slightly either side of 10.7 mc until maximum d-c volts is read across the volume control then adjust the primary of T6 for max.

8. For F.M.-R.F. alignment the output impedance of the signal generator should be 300 ohms to properly match the input impedance of this receiver.

9. The cover on the F.M. tuner must be in place during F.M.-R.F. alignment.

10. Set the band switch to the F.M. position.

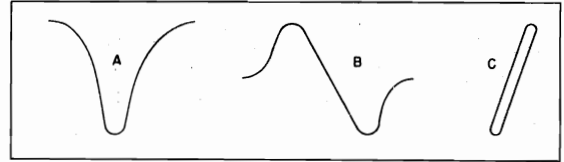

Fig. 4. ALIGNMENT CURVES

METER ALIGNMENT CHART

STEP NO.	SIGNAL GENERATOR FREQUENCY	SIGNAL INPUT POINT BETWEEN	TUNING CAPACITOR SETTING	ADJUST	SEE NOTE NO.
A.M.—I.F. ALIGNMENT					
1	455 kc, 30% mod. with 400 cycles	Pin 1 of V4 (12BA6) thru .02 mf. and chassis	Fully closed	Primary and secondary cores of T5 for maximum output meter reading	1, 2, 4
2		Pin 1 of V3 (12AU6) thru .02 mf. and chassis		Primary and secondary cores of T4 for maximum output meter reading	
A.M.—R.F. ALIGNMENT					
3	1620 kc, 30% mod. with 400 cycles	Pin 1 of V1 (6BJ6)	Fully open (min. cap.)	(C4) oscillator trimmer for maximum output meter reading	1, 2, 4
4	1500 kc, 30% mod. with 400 cycles		For maximum output meter reading	R-f trimmer (C-3) for maximum output meter reading while rocking gang condenser	
5			Inductively coupled to the loop. See note 3	Adjust antenna trimmer (C2) on loop for maximum	
F.M.—I.F. ALIGNMENT					
6	10.7 mc unmodulated	Pin 1 of V4 (12BA6) thru 100 mmf. and chassis	Fully closed	Core of L3 for maximum d-c reading at test point on rear of chassis	5, 10
7		Pin 1 of V3 (12AU6) thru 100 mmf. and chassis		Cores of T3 for maximum d-c volts at test point on rear of chassis	
8		Stator of C2001 thru .02 mf. thru hole in bottom of F.M. tuner cover		Cores of T2 for maximum d-c volts at test point on rear of chassis	
F.M. DISCRIMINATOR (T6) ALIGNMENT					
9	10.7 mc unmodulated	Pin 1 of V4 (12BA6) thru 100 mmf. and chassis	Fully closed	T6 secondary core for zero output across volume control (R16)	6, 10
10	Detune for maximum d-c at R16. See note 7			T6 primary core for maximum d-c volts across the volume control (R16)	6, 7, 10
F.M.—R.F. ALIGNMENT					
11	108.5 mc	At F.M. antenna terminals with built-in F.M. antenna disconnected	Fully open (min. cap.)	F.M. oscillator trimmer C2004 for maximum d-c volts at test point on rear of chassis	5, 8, 9, 10
12				F.M.-R.F. trimmer C2002 for maximum d-c volts at test point on rear of chassis while rocking signal generator frequency	

A.M. VISUAL ALIGNMENT NOTES

1. Connect the vertical plates of the scope from the junction of R9 and R11 to chassis for steps 1 through 4 of the AM Visual alignment.
2. Set band switch to AM position.
3. Rock the gang condenser when making the r-f adjustments as in step 4.
4. When adjusting the loop trimmer C2 the loop and back should be in their correct position with respect to the chassis.
5. For alignment of the r-f trimmers as in step 4 the signal should be inductively coupled to the loop by connecting a four turn six inch loop of bell wire across the signal generator terminals. The position of this loop with respect to the radio loop should not be changed during alignment to prevent possible error in comparative readings.

F.M. VISUAL ALIGNMENT NOTES

6. Set band switch to F.M. position.

7. When connecting the input to the receiver always make the chassis connection as close as possible to the point of input. Dress cables away from the r-f end of the chassis to prevent regeneration.
8. Connect the Vertical plates of the scope through meg to pin 3 of V6 (19T8) and to chassis to view the discriminator response curve.
9. Connect the Vertical plates of the scope to the limiter test point on the rear of the chassis and to chassis to view the response curve during F.M.-I.F. and R.F. alignment.
10. During F.M. alignment keep the signal input low to prevent limiting.
11. The termination impedance of the signal generator should be 300 ohms to properly match the input impedance of this receiver.

MODEL 409

12. In some cases tuning of the converter grid will cause "pulling in" of the oscillator and will change the oscillator frequency. If peaking of C3 or C2002 for max causes the curve to move off the screen it may be necessary to recalibrate the oscillator as in steps 3 or 11.

VISUAL ALIGNMENT CHART

STEP NO.	SIGNAL GENERATOR FREQUENCY	SIGNAL INPUT POINT BETWEEN	TUNING CAPACITOR SETTING	ADJUST	SEE NOTE NO.	
A.M.—I.F. ALIGNMENT						
1	455 kc F.M. modulated \pm 20 kc at 60 CPS	Pin 1 of V4 (12BA6) thru .02 mf. cap and chassis	Fully closed	Cores of T5 for curve of Fig. 4A with max. amplitude and symmetry	1, 2	
2		Pin 1 of V3 (12AU6) thru .02 mf. cap and chassis		Cores of T4 for curve of Fig. 4A with max. amplitude and symmetry		
A.M.—R.F. ALIGNMENT						
3	1620 kc A.M. modulated with 60 CPS	Pin 1 of V1 (6BJ6) thru .02 mf. and chassis	Fully open minimum capacity	Oscillator trimmer (C4) for steepest slope of straight line trace on scope. See Fig. 4C	1, 2, 12	
4	1500 kc F.M. modulated \pm 20 kc at 60 CPS	Inductively coupled to loop. See note	Adjust for max. amplitude of response curve	Adjust r-f trimmers C3 and C2 on loop for maximum amplitude and symmetry. See Fig. 4A	1, 2, 3, 4, 5, 12	
F.M.—I.F. ALIGNMENT						
5	10.7 mc F.M. modulated \pm 300 kc at 60 CPS	Pin 1 of V4 (12BA6) thru 100 mmf. and chassis	Closed	Secondary core of T6 for curve of Fig. 4B	6, 7, 8	
6				Primary core of T6 for max. amplitude and symmetry of curve of Fig. 4B	6, 7, 8, 10	
7				Core of L3 for max. amplitude and symmetry of curve of Fig. 4A	6, 7, 9, 10	
8				Pin 1 of V3 (12AU6) thru 100 mmf. and chassis		Cores of T3 for maximum amplitude and symmetry of curve of Fig. 4A
9				Stator of C2001 thru 100 mmf. and chassis hole in tuner cover		Primary and secondary cores of T2 for maximum amplitude and symmetry of curve of Fig. 4A
10			Retouch primary and secondary cores of T6 for maximum amplitude and symmetry of curve of Fig. 4B	6, 7, 8, 10		
F.M.—R.F. ALIGNMENT						
11	108.5 mc A.M. modulated at 60 CPS	At F.M. antenna terminals (built in F.M. antenna disconnected)	Fully open minimum capacity	Oscillator trimmer C2004 for steepest slope of straight line trace of Fig. 4C	6, 7, 9, 10, 11, 12	
12	108 mc		For maximum amplitude of curve	C2002 for maximum amplitude and symmetry of curve of Fig. 4A		

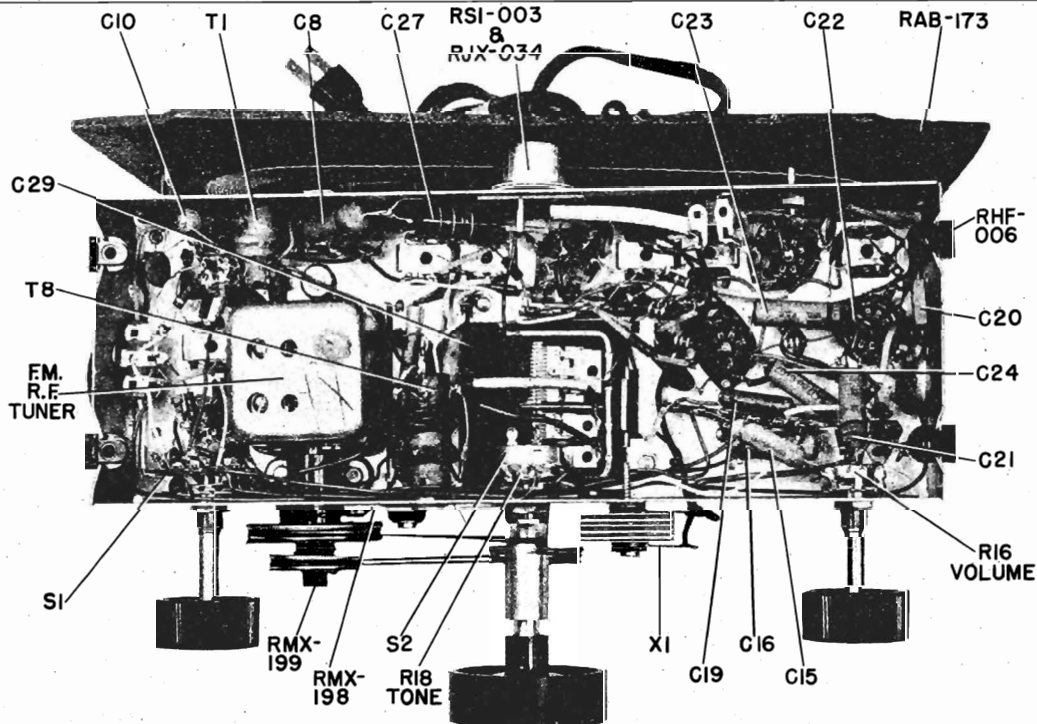

Fig. 6. BOTTOM VIEW

MODEL 409

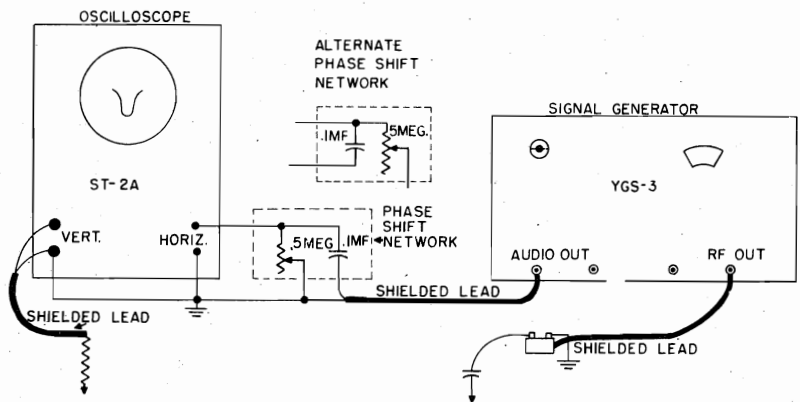

Fig. 7. VISUAL ALIGNMENT CONNECTIONS

PARTS LIST

Cat. No.	Symbol	Description	Unit Price	Cat. No.	Symbol	Description	Unit Price
CAPACITORS				COILS AND TRANSFORMERS (Cont'd)			
*RCE-101	C25A, 25B	40-80 mfd., 150 v., electrolytic	\$2.00	*RTL-111	T5	I.F. TRANSFORMER—2nd B.C.	\$2.10
*RCN-040	C5	6 mmf., ceramic	.25	*RTL-112	T2	I.F. TRANSFORMER—1st F.M.	1.80
*RCN-046	C2010	18 mmf., silver mica	.25	*RTL-128	T4	I.F. TRANSFORMER—1st B.C.	2.10
*RCN-048	C2014, 33	1.5 mmf., ceramic	.20	RTL-129	T3	I.F. TRANSFORMER—2nd F.M.	2.25
RCT-055	C2001, 2002, 2003, 2004	F.M. tuning capacitor	3.50	RTL-130	L3	I.F. COIL—3rd F.M.	2.10
RCT-056	C1A, 1B, 1C	A.M. tuning condenser		RTO-112	T7	OUTPUT TRANSFORMER	2.75
*RCW-026	C2007	.0015 mf., ceramic	.25	MISCELLANEOUS ELECTRICAL			
*RCW-176	C6, 32	470 mmf., ceramic	.25	*RJC-004		TERMINAL—For loop connections	\$0.02
*RCW-3014	C11, 12, 13, 14, 17, 28, 34, 35, 2013	.005 mf., hi-k, ceramic	.25	*RJS-118		TUBE SOCKET—For V6	.35
*RCW-3016	C2012	20 mmf., ceramic	1.00	*RJS-125	V1, 3, 4, 5, 7	TUBE SOCKET	.20
RCW-3065	C2009	22 mmf., ceramic	.60	*RJS-174		TUBE SOCKET—For V2	
RCY-016	C2	Trimmer, 2-20 mmf.	.35	*RJX-034		INTERLOCK—Female terminal cap and insulator	.45
*UCC-011	C8, C29	.05 mf., 200 v., paper	.30	*RER-010		SELENIUM RECTIFIER	1.60
*UCC-035	C19	.001 mf., 600 v., paper	.30	*RSI-003		INTERLOCK—Male	.15
*UCC-036	C15	.002 mf., 600 v., paper	.25	RSW-090	S1A, 1B, 1C, 1D, 1F	BAND SWITCH	2.25
*UCC-037	C16	.003 mf., 600 v., paper	.25	*RWL-022		POWER CORD SET	1.25
*UCC-039	C24	.005 mf., 600 v., paper	.25	*RWS-031		PILOT LIGHT ASSEMBLY	.50
*UCC-040	C10, 21, 23	.01 mf., 600 v., paper	.25	*IRS-527D		SPEAKER—5 1/2 in.	4.60
*UCC-045	C27	.05 mf., 600 v., paper	.30	MISCELLANEOUS MECHANICAL			
*UCG-004	C2006	10 mmf., silver mica	.25	RAC-099		COVER—For F.M. tuner	
*UCG-016	C18	33 mmf., silver mica	.25	*RDC-032		DIAL CORD—25 yds.	\$2.50
*UCG-020	C22, 36	47 mmf., silver mica	.35	*RDE-080		ESCUTCHEON—(Cabinet)	1.90
*UCG-1011	C9	20 mmf., silver mica	.25	RDP-065		POINTER	.35
*UCG-1026	C2008	82 mmf., silver mica	.25	RDS-111		DIAL SCALE	2.35
*UCU-044	C20	470 mmf., mica	.30	*RHC-018		CLIP—For mounting loop and back	.05
RESISTORS				*RHC-038		CLIP—For mounting B.C.—R.F. transformer T8	.02
RRC-177	R16	Volume control	\$1.25	*RHC-034		CLIP—Coil mounting for L3	.05
RRC-178	R18	Tone control	1.60	*RHC-049		CLIP—For mounting escutcheon around dial	.02
RRW-084	R26	1000 ohms, 2 w., w.w.	.35	*RHF-006		CHASSIS FOOT	.15
RRW-085	R32	33 ohms, 2 w., w.w.	.35	*RHG-015		GROMMET—Tuning gang mounting	.05
*URD-009	R27	22 ohms, 1/2 w., carbon	.13	RHH-004		SNAP FASTENER—For fastening back onto cabinet	.02
*URD-025	R1, 3, 5, 7	100 ohms, 1/2 w., carbon	.13	*RHM-025		"C" TYPE RETAINING RING on tone control shaft	.01
*URD-031	R14	180 ohms, 1/2 w., carbon	.13	RHS-091		TUBE SHIELD—For V2	
*URD-033	R2, 6, 30	220 ohms, 1/2 w., carbon	.13	RMC-002		CLIP—(Coil mounting)—for B.C. oscillator coil, T1	.05
*URD-041	R8	470 ohms, 1/2 w., carbon	.13	*RMS-130		SPRING—(LG Drum of F.M. tuner)	.15
*URD-053	R2001	1500 ohms, 1/2 w., carbon	.13	*RMS-243		SPRING—Tension, for pointer drive cord	.10
*URD-057	R4	2200 ohms, 1/2 w., carbon	.13	RMS-274		SPRING	.02
*URD-081	R15, R2002	22,000 ohms, 1/2 w., carbon	.13	RMU-080		TUNING SHAFT	.60
*URD-089	R9, 12, 31	47,000 ohms, 1/2 w., carbon	.13	RMX-198		LINK ROLLER ASSEMBLY—Includes shoulder rivets	.60
*URD-097	R13, 17, 21	100,000 ohms, 1/2 w., carbon	.13	RMX-199		DRUM AND BUSHING ASSY.—On F.M. tuner	.85
*URD-099	R19, 20	120,000 ohms, 1/2 w., carbon	.13	CABINETS AND CABINET PARTS			
*URD-105	R11	220,000 ohms, 1/2 w., carbon	.13	RAB-173		LOOP AND BACK ASSEMBLY	\$2.25
*URD-113	R23, 24, 28, 29	470,000 ohms, 1/2 w., carbon	.13	*RAD-049		BRACKET—Pilot light	.05
*URD-029	R25	150 ohms, 1/2 w., carbon	.13	RAU-355		CABINET—409	8.50
*URD-129	R10	2.2 meg., 1/2 w., carbon	.13	*RDK-211		KNOB—Volume	.25
*URD-141	R22	6.8 meg., 1/2 w., carbon	.13	RDK-265		KNOB—Tuning	.25
*URD-145	R33	10 meg., 1/2 w., carbon	.13	RDK-266		KNOB—Tone	.20
COILS AND TRANSFORMERS				RDK-267		KNOB—Band	.25
RLB-031	L2003	F.M.—R.F.—COIL	\$0.15				
RLB-032	T8	COIL—B.C.—R.F.	1.50				
RLC-114	L2004	F.M. OSCILLATOR COIL	.15				
RLC-115	T1	COIL—B.C. OSCILLATOR	.90				
*RLI-122	L4, L2002, 2005, 2006, 2007	CHOKE—A.M. LOOP (2.2 uh)	.25				
*RLI-124	L2001	R.F. PLATE—Choke	.80				
*RLI-163	L1	CHOKE—F.M. ANTENNA	.15				
*RTD-006	T6	F.M. DISCRIMINATOR TRANSFORMER	4.95				

*PARTS USED ON PREVIOUS RECEIVERS

PRICES SUBJECT TO CHANGE WITHOUT NOTICE

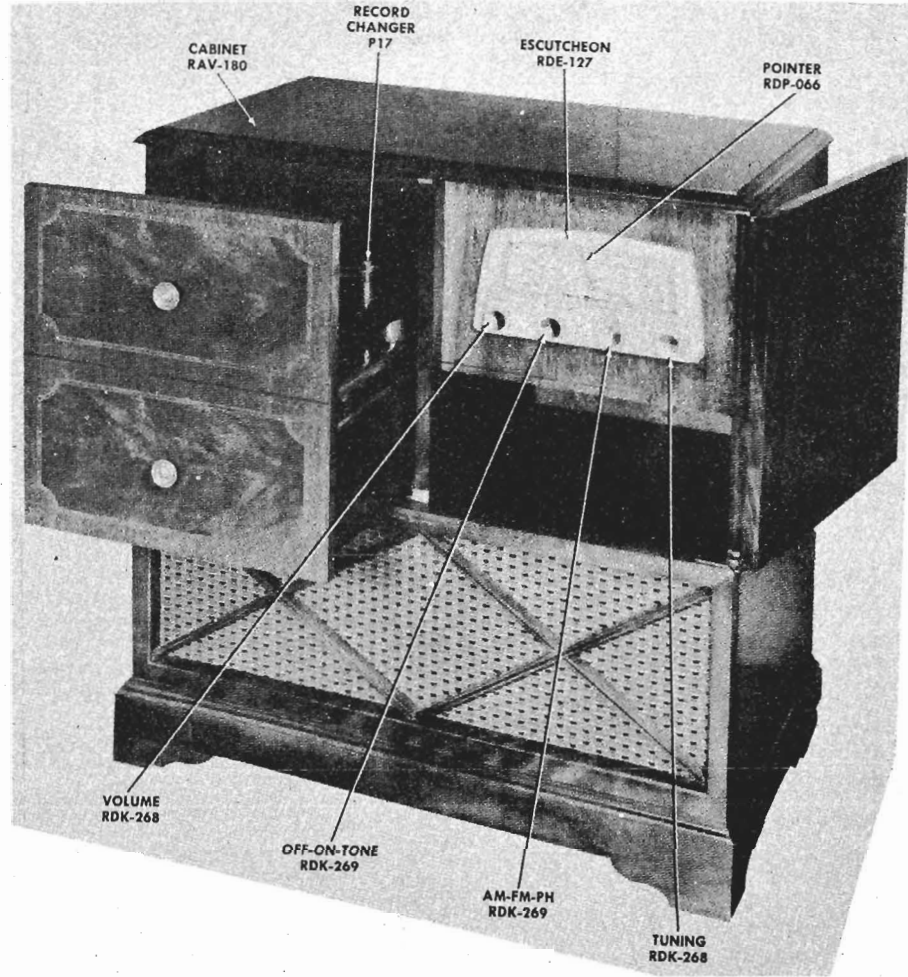

SPECIFICATIONS

CABINET:

	754	756
Material	Wood	Wood
Color	Mahogany	Blonde
Height	33 1/8 in.	33 1/8 in.
Width	33 in.	33 in.
Depth	17 in.	17 in.

ELECTRICAL RATING:

Voltage	105-125
Frequency	60 cycles
Wattage (Radio only)	85 watts
(With phono)	100 watts

OPERATING FREQUENCIES:

AM-RF	540-1600 kc
FM-RF	88-108 mc
AM-IF	455 kc
FM-IF	10.7 mc

AUDIO POWER OUTPUT (120 VOLTS LINE):

Undistorted	3 watts
Maximum	5 watts

LOUDSPEAKER:

Type	Alnico PM
------	-----------

Size	12 inches
Voice Coil Impedance at 400 cycles	3.2 ohms

RECORD CHANGER:

Model P17	33 1/8, 45 and 78 RPM
-----------	-----------------------

PHONOGRAPH PICKUP:

Type	Dual stylus, variable reluctance
DC Resistance	340 ohms

ANTENNA:

AM External or built-in-loop
 FM Powerline antenna or 300-ohm FM ant.
 If it is necessary to install an external FM antenna, the built-in powerline antenna should be disconnected from the antenna terminals.

TUBE COMPLEMENT:

(V1) RF Amplifier	6BJ6
(V2) FM Oscillator Converter, AM Osc.	12AT7
(V3) 1st FM IF, AM Converter	6BA6
(V4) AM FM I-F Amplifier, Phono Preamp	6AU6
(V5) FM Limiter	6AU6
(V6) FM Discriminator, AM Detector, 1st Audio Amplifier	6T8
(V7) Rectifier	6V6
Dial Lamp	Mazda #47

MODELS 754, 756

STAGE GAINS

Stage gain measurements using a vacuum tube voltmeter or oscilloscope with a calibrated signal generator may be used to check circuit performance and isolate trouble. Use small signals to eliminate AVC action. Tolerance 20%. Signal applied through 470 ohm resistor and 1000 mmfd. capacitor in series.

STAGE	GAIN AM	GAIN FM
Ant. to V1 Grid	1 (98 MC)
V1—V2 Grid	6 (98 MC)
V1—V3 Grid	14 (1000 KC)
V2—V3 Grid	10 (10.7 MC)
V3—V4 Grid	70 (455 KC)	45 (10.7 MC)
V4—V5 Grid	(455 KC)	20 (10.7 MC)
V6—V4 Grid	80 (455 KC)

OSCILLATOR GRID BIAS:

DC voltage developed across R2002. Use 100K resistor to isolate meter. Tolerance 20%.

	VTVM	20K ohms/voltmeter
1000 KC	7 volts	4 volts
98 MC	3 volts	2 volts

HUM MEASUREMENT

Hum measured across the voice coil of the speaker with the volume control set at minimum and band switch in the AM position should not exceed 7 millivolts.

On FM position ground the limiter grid through a .01 mfd. capacitor and measure the hum across the voice coil with volume control at maximum. Hum should not exceed 15 millivolts.

ANTENNA CONNECTIONS

This receiver is designed to operate on a built-in AM and a point as possible.

built-in FM antenna or from an external AM and an external 300 ohm FM antenna.

If no external AM antenna is used, the AM antenna terminal should be connected to the chassis ground by the shorting link.

If an external FM antenna is used the built-in FM antenna (third wire of the power cord) should be disconnected from the FM antenna terminal.

If the built-in FM antenna is to be used, it should be connected to the high side of the FM input terminals (second terminal from the right side of the terminal board).

METER ALIGNMENT NOTES

1. Connect an output meter across the speaker leads to indicate maximum output.
2. Turn volume control to maximum clockwise position and reduce signal input so that output meter does not indicate more than 1/2 watt output.
3. Band switch set in AM position.
4. Connect an 18 microhenry choke across the loop terminals to assimilate the loop during alignment.
5. Connect a vacuum tube voltmeter from the limiter grid test point to chassis to read the d-c voltage developed at the limiter grid during FM-IF and RF alignment. Dress the leads to the vacuum tube voltmeter leads away from the r-f end of the chassis to prevent regeneration. Reduce signal input so that V.T.V.M. reads approximately 1 volt d-c at limiter grid test point.
6. Connect a vacuum tube voltmeter across the volume control and align the secondary of T8 for zero output at 10.7 mc.
7. Detune the signal generator either side of 10.7 mc until maximum d-c volts across the volume control is read—then peak the primary core of T8.
8. For FM-RF alignment the output impedance of the signal generator cable should be 300 ohms to properly match the input impedance of this receiver.
9. The cover over the FM-RF tuner must be in place during FM-RF alignment.
10. Band switch in FM position.
11. Make the chassis connection as close to the signal input

METER ALIGNMENT CHART

Step No.	Signal Generator Frequency	Signal Input Point Between	Tuning Gang Capacitor	Adjust	See Note No.	
AM-IF ALIGNMENT						
1	455 KC 30% mod. with 400 cycles	Pin 1 of V4 (6AU6) thru .02 mf. and chassis	Closed	Primary and secondary cores of T7 for max. output meter reading	1, 2, 3	
2		Pin 1 of V3 (6BA6) thru .02 mf. and chassis		Primary and secondary cores of T6 for max. output meter reading. Re-check adjustment of T7 cores		
AM-RF ALIGNMENT						
3	1620 KC 30% mod. with 400 cycles	Pin 1 of V1 (6BJ6) thru .02 mf. and chassis	AM gang cap. fully open. (Min. cap.)	Adjust oscillator trimmer (C36) for maximum output meter reading.	1, 2, 3	
4	1500 KC 30% mod. with 400 cycles			Adjust r-f trimmer (C7) for maximum output meter reading while rocking gang condenser.		
5	580 KC 30% mod. with 400 cycles		AM antenna terminals thru I. R. E. dummy antenna	Tuning gang for max. output meter reading.	Core of T1 for maximum	1, 2, 3, 4
6	1500 KC 30% mod. with 400 cycles				Adjust antenna trimmer C5 for maximum	
FM-IF ALIGNMENT CHART						
7	10.7 mc unmodulated	Pin 1 of V4 (6AU6) thru 100 mmf. and chassis	Closed	Core of L3 for max. d-c voltage at test point on rear of chassis	5, 10, 11	
8		Pin 1 of V3 (6BA6) thru 100 mmf. and chassis		Cores of T5 for max. d-c volts at limiter test point		
9		Stator of C2001 thru 100 mmf. thru hole in bottom of tuner cover		Cores of T4 for max. d-c volts at limiter test point		
FM DISCRIMINATOR ALIGNMENT						
10	10.7 mc unmodulated	Pin 1 of V4 thru 100 mmf. and chassis	Closed	T8 secondary core for zero output across the volume control R28 at 10.7 mc	6, 10, 11	
11	Detune for max. d.c. at R28. See Note 7.			T8 primary core for max. d-c volts across the volume control R28	6, 7, 10, 11	
FM-RF ALIGNMENT						
12	108.5 mc	At FM antenna terminals	Tuning capacitor fully open	Oscillator trimmer C2004 for maximum d-c voltage at limiter grid test point.	5, 8, 9, 10, 11	
13	108 mc		Tune for maximum	FM-RF trimmer C2002 for max. output at limiter grid test point while rocking signal generator		
14	Recheck oscillator alignment as in Step 12.					

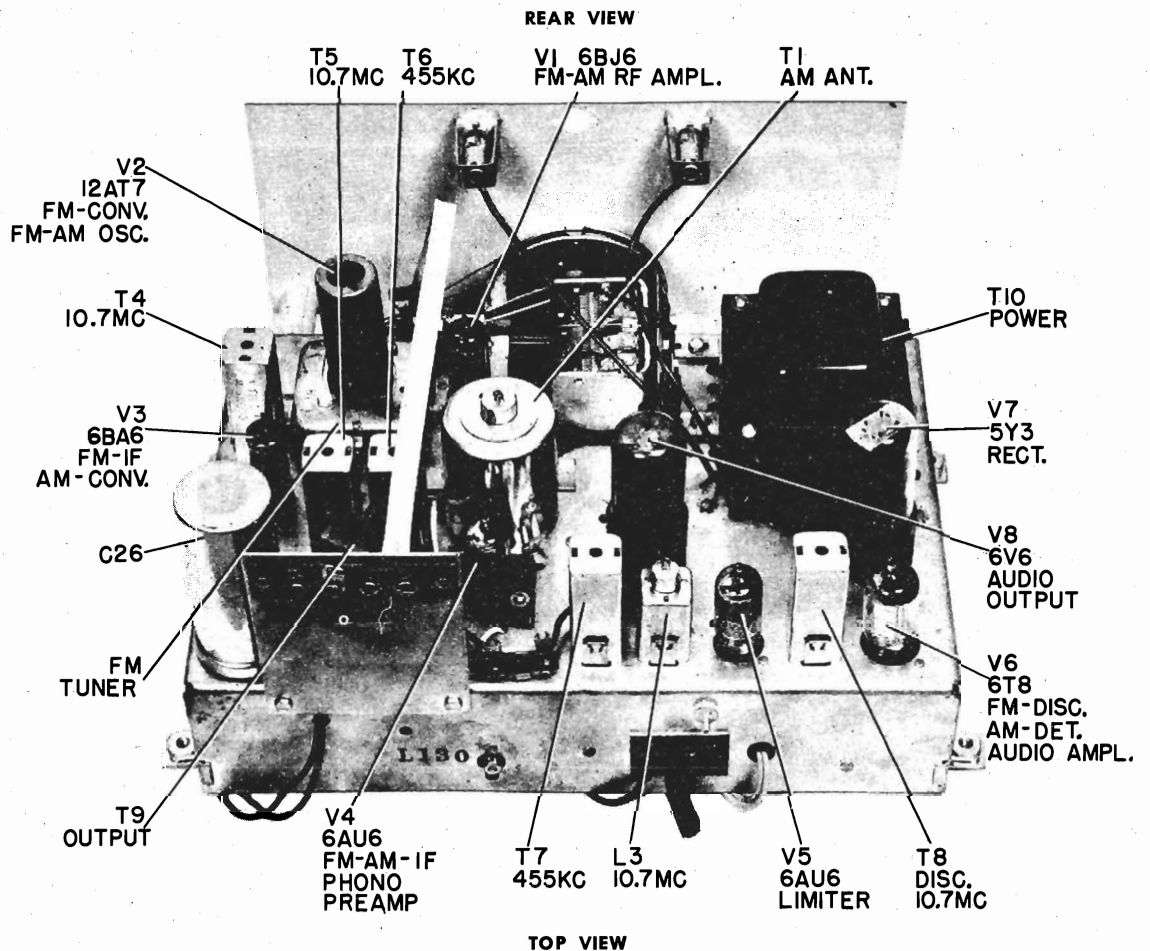
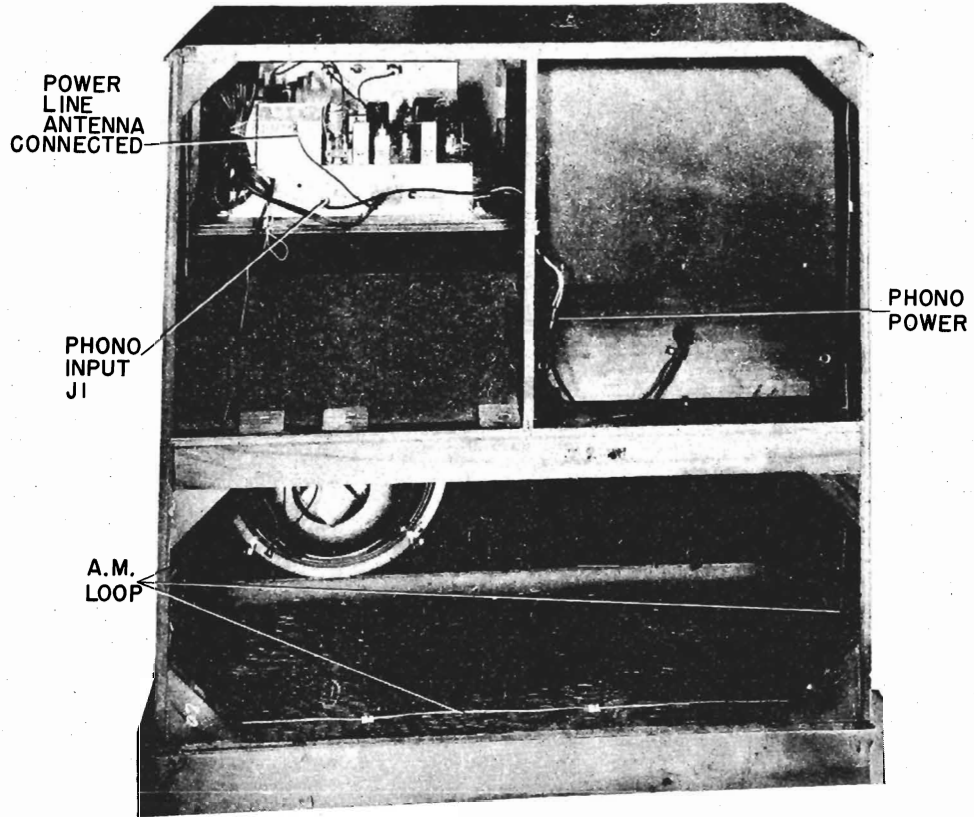

MODELS 754, 756

EQUIPMENT REQUIRED FOR METER ALIGNMENT

1. Signal generator (G.E.-YGS-3 or equivalent)
2. Vacuum tube voltmeter
3. Output meter
4. One 18 microhenry choke to assimilate the loop
5. .02 mf capacitor
6. 100 mmf capacitor

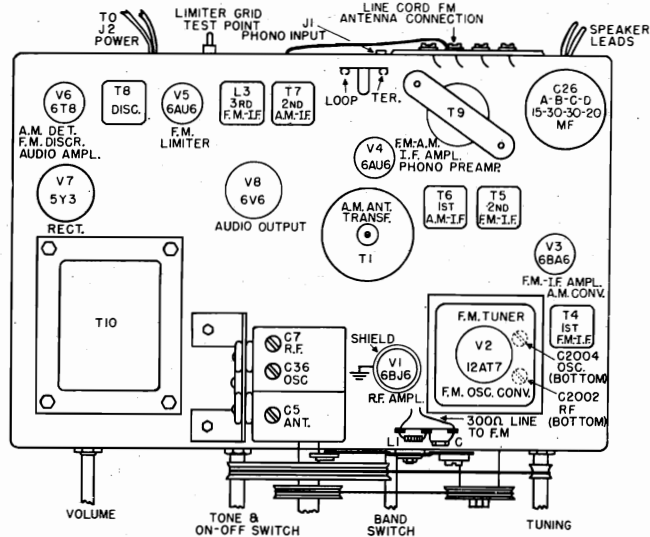

FIG. 1. TOP VIEW

VISUAL ALIGNMENT NOTES

1. Set the band switch to AM position.
2. Connect the vertical plates of the scope across the volume control for AM alignment.
3. Use a frequency modulated sweep with its center frequency, at the frequency specified. Connect the same frequency that modulates the signal to the horizontal plates of the scope.
4. Keep signal generator input low so that A.V.C. does not take place.
5. Visual oscillator alignment is done by using a signal amplitude modulated with 60 c.p.s. and sweeping the horizontal plates of the scope with the same frequency. As the receiver is tuned to the signal frequency the slope of the straight line trace will become steeper.
6. During AM-RF alignment connect an 18 microhenry

choke across the loop terminals to assimilate the loop during alignment.

7. Shield of input cable should be connected to chassis as close to the point of input as possible.
8. Connect the vertical plates from the limiter grid test point on the rear of the chassis, to chassis for FM-IF and RF alignment. The cable should be dressed away from the r-f end of the chassis to prevent possible regeneration.
9. Connect the vertical plates of the scope from pin 3 of V6 (6T8) through 200,000 ohm resistor and to chassis to view the discriminator response.
10. The output impedance of the sweep generator should match the 300 ohm input impedance of this receiver during FM-RF alignment.
11. Set the band switch to FM position.

VISUAL ALIGNMENT CHART

Step No.	Signal Generator Frequency	Signal Input Point Between	Tuning Gang Capacitor	Adjust	See Note No.
AM—IF ALIGNMENT					
1	455 KC with FM sweep ± 20 KC at 60 cps	Pin 1 of V4 (6AU6) thru .02 mf. and chassis		Primary and secondary cores of T7 for max. amplitude and symmetry of curve of Fig. 3A.	1, 2, 3, 4, 7
2		Pin 1 of V3 (6BA6) thru .02 mf. and chassis		Primary and secondary cores of T6 for max. amplitude and symmetry of curve of Fig. 3A.	
AM—RF ALIGNMENT					
3	1620 KC AM modulated at 60 cps	Pin 1 of V1 (6BJ6) thru .02 mf. and chassis	AM gang cap. fully open (min. cap.)	Adjust oscillator trimmer (C36) for steepest slope of trace on screen. See Fig. 3C.	1, 2, 4, 5, 7
4	1500 KC freq. mod. ± 20 KC at 60 cps		C7 r-f trimmer for max. amplitude and symmetry of curve of Fig. 3A	1, 2, 3, 4, 7	
5	580 KC freq. mod. ± 20 KC at 60 cps		AM antenna terminal through I. R. E. dummy antenna and chassis	Core of T1 for maximum amplitude and symmetry of curve of Fig. 3A	1, 2, 3, 4, 6, 7
6	1500 KC freq. mod. ± 20 KC at 60 cps		C5 antenna trimmer for max. amplitude and symmetry of curve of Fig. 3A.		
FM—IF ALIGNMENT					
7	10.7 mc freq. mod. $\pm .3$ mc at 60 cps	Pin 1 of V4 (6AU6) thru 100 mmf. and chassis	Closed	Core of L3 for max. amplitude and symmetry of curve of Fig. 3A.	4, 7, 8, 11
8		Pin 1 of V3 (6BA6) thru 100 mmf. and chassis		Cores of T5 for max. amplitude and symmetry of curve of Fig. 3A.	
9		Stator of C2001 thru 100 mmf. and chassis		Cores of T4 for max. amplitude and symmetry of curve of Fig. 3A.	
FM DISCRIMINATOR ALIGNMENT					
10	10.7 mc freq. mod. $\pm .3$ mc at 60 cps	Pin 1 of V4 thru 100 mmf. and chassis	Closed	T8 secondary core for curve of Fig. 3B.	4, 7, 9, 11
11				T8 primary core for max. ampl. and symmetry 3B.	
12				Retouch secondary core of T8 for symmetry	
FM—RF ALIGNMENT					
13	108.5 mc ampl. mod. with 60 cps	At FM antenna terminals	Fully open (min. cap.)	Osc. trimmer C2004 for steepest slope of trace Fig. 3C.	4, 5, 7, 8, 10, 11
14	108 mc freq. mod. $\pm .3$ mc at 60 cps		Tune for maximum	FM—RF trimmer C2002 for max. ampl. and symmetry of curve of Fig. 3A.	4, 7, 8, 10, 11

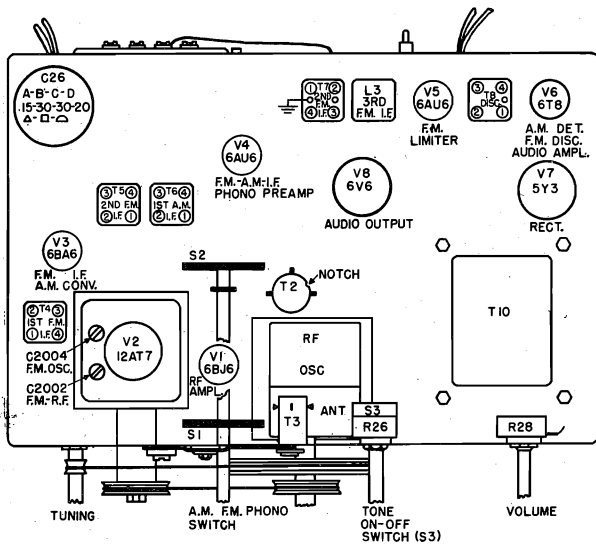

FIG. 2. BOTTOM VIEW

EQUIPMENT REQUIRED FOR VISUAL ALIGNMENT

1. Scope (G.E.ST2A or equivalent)
2. Sweep Generator (G.E. YG S-3 or equivalent)
3. Phase shift network as shown in Fig. 10
4. .02 mf capacitor
5. 100 mmf capacitor
6. 200,000 ohm resistor to isolate scope.
7. One 18 microhenry choke to assimilate the loop.

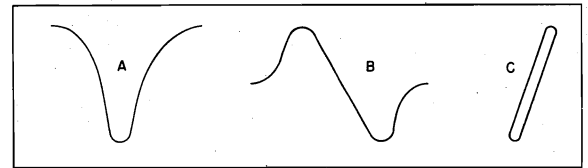

FIG. 3. ALIGNMENT CURVES

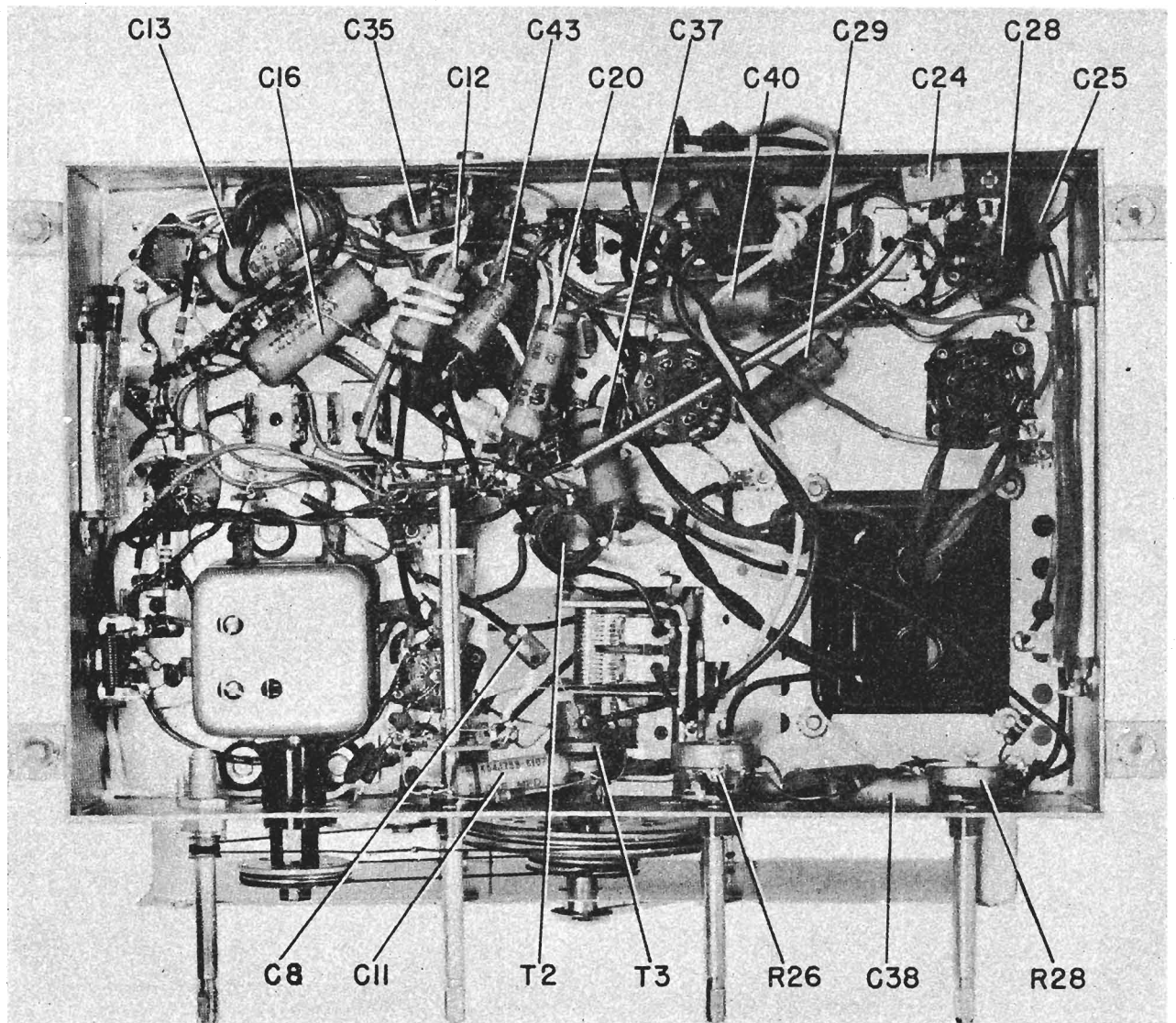
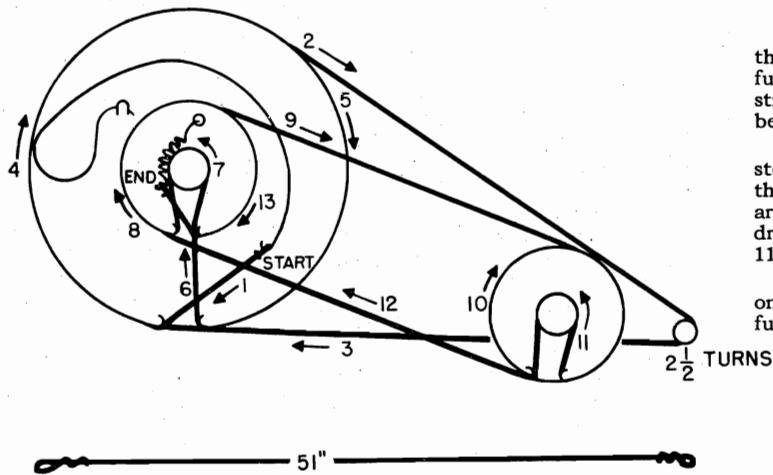

FIG. 4. BOTTOM VIEW OF CHASSIS

DIAL STRINGING



When stringing the dial cord both the A.M. and the F.M. tuning capacitor drums should be turned fully clockwise (minimum capacity). When the dial stringing is completed both tuning capacitors should be fully open or fully closed at the same time.

Steps 1, 2, 3, 4 and 5 are as shown in Fig. 5. At step 6 the cord is brought from the large drum onto the small drum as shown. Step 7 takes the cord around the axle and on to step 8 around the small drum of the A.M. tuning capacitor. Steps 9, 10, 11 and 12 are as shown in Fig. 5.

The pointer should be set opposite the last mark on the F.M. scale with the tuning capacitor in its fully clockwise position.

FIG. 5. DIAL STRINGING

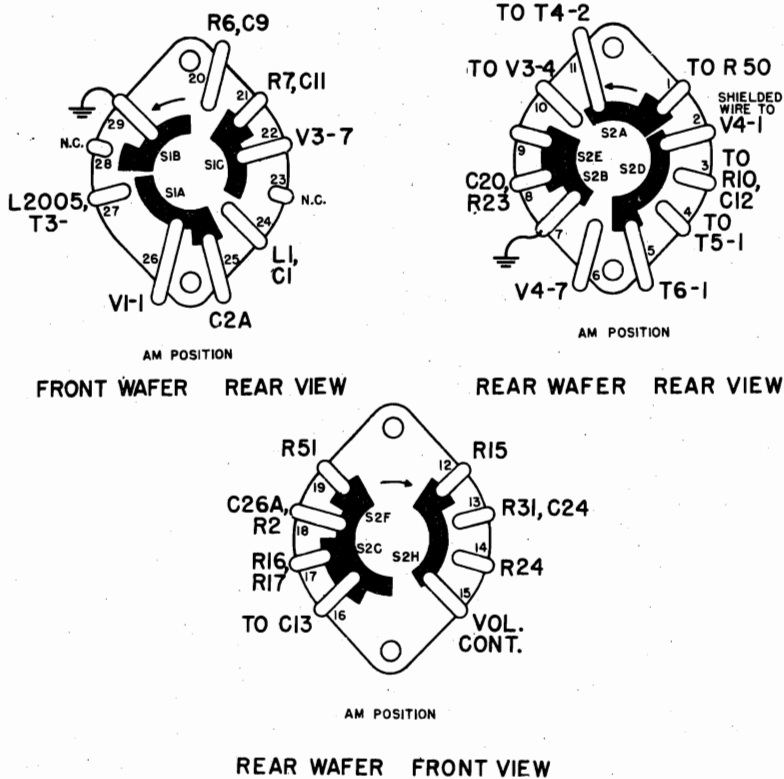
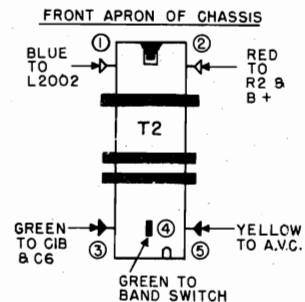

FIG. 7. SWITCH CONNECTIONS



R.F. TRANSF. CONNECTIONS

OSC. TRANSF. CONNECTIONS

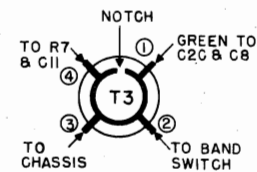

Fig. 8
COIL CONNECTIONS

MODELS 754, 756

PARTS LIST

Cat. No.	Symbol	Description	Unit Price	Cat. No.	Symbol	Description	Unit Price
CAPACITORS				COILS AND TRANSFORMERS (Cont'd)			
RCE-039	C26A, B, C	15 mf., 300 v., 30-30 mf., 350 v., 20 mf., 25 v.	\$3.50	RTL-132	L3	COIL—3rd FM—IF coil, 10.7 mc	
RCN-001	C2014	1 mmf.	.20	RTL-134	T7	TRANSFORMER—2nd AM—IF	
RCN-040	C1	6 mmf., ceramic	.25	RTO-113	T9	TRANSF.—Audio output	
RCN-046	C2010	18 mmf., silver mica	.25	RTP-311	T10	TRANSF.—Power, 60 cycle	
*RCN-048	C6	1.5 mmf.	.20	MISCELLANEOUS ELECTRICAL			
*RCT-055	C2001, C2002, 2003, 2004	F-M tuning capacitor	3.50	RHC-040		TUBE SHIELD base for V1	\$0.05
RCT-057	C2A, B, C	A.M. tuning capacitor		*RHS-091		SHIELD—For V2	
*RCW-026	C2007	1500 mmf., 300 v.	.25	RHW-034		WASHER — Insulated shoulder washer for mounting RJC-023	
*RCW-2031	C2012	18 mmf.	.60	*RII-047		WASHER—Phono jack washer for J1	.05
*RCW-3014	C9, 10, 14, 15, 21, 39	.005 mf.	.25	*RJC-019		PIN—Speaker lead pins	.02
RCW-3037	C42	800 mmf.	.25	RJC-023		PIN—Contact pin for limiter grid test point	
*RCW-3065	C2009	22 mmf.	.60	*RJP-003		A.C. PLUG—Female for 110V. A.C. on record changer	.15
RCW-3067	C3, 4	470 mmf.		*RJP-004		PHONO PLUG—Male (audio) on record changer	.10
*UCC-011	C12, 35, 37	.05 mf., 200 v.	.30	RJP-010		JACK—Phono jack (female)	.10
*UCC-022	C23, 28	.005 mf., 400 v.	.25	*RJS-003		SOCKET—Octal socket for V7 and V8	.20
*UCC-036	C22, 38	.002 mf., 600 v.	.25	*RJS-049	J2	SOCKET—Phono power socket (110 v.)	.25
*UCC-040	C11	.01 mf., 600 v.	.25	*RJS-118		SOCKET—Tube socket for V6 (9 pin)	.35
*UCC-041	C20, 29	.02 mf., 600 v.	.25	*RJS-141		SOCKET—Tube socket for V4 (shock mounted)	.20
*UCC-048	C13, 16	.1 mf., 600 v.	.45	*RJS-145		SOCKET—7 pin tube socket for V1, V3, V5	.30
UCC-059	C40	.005 mf., 1000 v.	.30	*RJS-174		SOCKET—Tube socket for V2	.40
*UCG-016	C17	33 mmf., silver mica	.25	RMM-166		TUBE SHIELD—For V1	.15
*UCG-004	C2006	10 mmf.	.25	RPJ-014		STYLUS—Stylus and guide assembly, dual heavy bar type Hi Output 1 & 3 mil	5.95
UCG-020	C27	47 mmf., silver mica	.35	*RPX-048		PICKUP CARTRIDGE — Phono pickup	13.95
*UCG-1012	C8	22 mmf., silver mica	.35	RSW-091	S1, S2	SWITCH—AM—FM—phono switch	
*UCG-1026	C2008	82 mmf., silver mica	.25	RWX-044		SOCKET—Pilot light socket for dial scale	
UCU-044	C25	470 mmf.	.30	*S1212D-7		SPEAKER—12 inch PM	12.95
UCU-536	C24	220 mmf.	.30	MISCELLANEOUS MECHANICAL			
RESISTORS				*RDC-032		DIAL CORD—N.F. 28	\$2.50
RRC-179	R26, S3	Tone control 4 meg. and on-off switch		RDS-112		SCALE—Back plate and dial scale	
RRC-180	R28	Volume control 2 megohms		RDP-066		POINTER—Dial pointer	
RRW-086	R51	600 ohms W. W.		*RHC-038		CLIP—Mounting clip for mounting AM—RF coil T2	.02
RRW-087	R53, 54	Dual 650 ohms & 1800 W. W. ohms		*RHG-010		GROMMET—Rubber for shock mounting V4	.05
*URD-019	R29	47 ohms	\$0.13	RHI-022		STRAIN RELIEF—For power cord	
*URD-025	R1, 4, 6	100 ohms, 1/2 w., carbon	.13	*RMC-002		CLIP—For mounting oscillator coil T3	.05
*URD-029	R11	150 ohms, 1/2 w., carbon	.13	*RMS-111		SPRING—Dial cord tension spring in large drum	.15
*URD-031	R22	180 ohms, 1/2 w., carbon	.13	*RMS-243		SPRING—Coil spring in small drum for dial cord tension	.10
*URD-041	R5, 8, 48	470 ohms, 1/2 w., carbon	.13	*RMS-274		SPRING—For mounting insulated shaft and drive drum on FM tuning capacitor	.02
*URD-045	R50, 7	680 ohms, 1/2 w., carbon	.13	RMX-201		SHAFT—Tuning drive shaft assembly	
*URD-049	R16, 42	1000 ohms, 1/2 w., carbon	.13	RMX-202		ROLLER—Link and roller assembly between tuning capacitor shafts	.35
*URD-053	R2001	1500 ohms, 1/2 w., carbon	.13	RMX-203		DRUM—For FM tuning capacitor insulated shaft	.15
*URD-061	R12	3,300 ohms, 1/2 w., carbon	.13	RWL-028		CORD—Three wire power cord	
*URD-065	R2	4700 ohms, 1/2 w., carbon	.13	CABINETS AND CABINET PARTS			
*URD-079	R9	18,000 ohms, 1/2 w., carbon	.13	RAV-180		CABINET—Mahogany for 754	
*URD-081	R30, 2002	22,000 ohms, 1/2 w., carbon	.13	RAV-181		CABINET—Blonde for 756	
*URD-089	R15	47,000 ohms, 1/2 w., carbon	.13	RDE-127		ESCUTCHEON—For dial scale	
*URD-097	R21, 24, 27, 31	100,000 ohms, 1/2 w., carbon	.13	RDK-268		KNOB—Tuning and volume control knob	
*URD-099	R34, 35	120,000 ohms, 1/2 w., carbon	.13	RDK-269		KNOB—With dot for tone, ON-OFF and AM—FM—PH. switch controls	
*URD-101	R14, 24	150,000 ohms, 1/2 w., carbon	.13	COILS AND TRANSFORMERS			
*URD-105	R18, 23, 37	220,000 ohms, 1/2 w., carbon	.13	RLA-038	T1	TRANSF.—AM antenna	
*URD-113	R20, 39, 45	470,000 ohms, 1/2 w., carbon	.13	*RLB-031	L2003	COIL—FM—RF coil	\$0.15
*URD-121	R17, 49	1 megohm, 1/2 w., carbon	.13	RLC-033	T2	TRANSF.—AM—RF	
*URD-129	R19	2.2 megohms, 1/2 w., carbon	.13	RLC-114	L2004	COIL—FM oscillator coil	.15
*URD-131	R13	2.7 megohms, 1/2 w., carbon	.13	RLC-116	T3	TRANSF.—AM oscillator	
*URD-139	R55	Resistor 5.6 meg 1/2 w.	.13	*RLI-102	L2005, 2006, 2007	COIL—Choke coil, 1 milhenry	.35
*URD-141	R10, 36	6.8 megohms, 1/2 w., carbon	.13	*RLI-122	L2002, 2008	COIL—2.2 milhenry choke coil	.25
*URE-037	R52	330 ohms, 1 w., carbon	.13	RLI-124	L2001, L4	COIL—RF plate choke coil	.80
COILS AND TRANSFORMERS				RLI-164	L1	COIL—FM antenna coil	.35
RLA-038	T1	TRANSF.—AM antenna		RLL-048	L2	LOOP—AM antenna loop	
*RLB-031	L2003	COIL—FM—RF coil	\$0.15	RTD-010	T8	TRANSF.—Discriminator trans- former, 10.7 mc	4.95
RLC-033	T2	TRANSF.—AM—RF		RTL-112	T4	TRANSF.—1st FM—IF	1.80
RLC-114	L2004	COIL—FM oscillator coil	.15	RTL-113	T5	TRANSF.—2nd FM—IF	2.25
RLC-116	T3	TRANSF.—AM oscillator		RTL-131	T6	TRANSF.—1st AM—IF	
*RLI-102	L2005, 2006, 2007	COIL—Choke coil, 1 milhenry	.35				
*RLI-122	L2002, 2008	COIL—2.2 milhenry choke coil	.25				
RLI-124	L2001, L4	COIL—RF plate choke coil	.80				
RLI-164	L1	COIL—FM antenna coil	.35				
RLL-048	L2	LOOP—AM antenna loop					
RTD-010	T8	TRANSF.—Discriminator trans- former, 10.7 mc	4.95				
RTL-112	T4	TRANSF.—1st FM—IF	1.80				
RTL-113	T5	TRANSF.—2nd FM—IF	2.25				
RTL-131	T6	TRANSF.—1st AM—IF					

PRICES ARE SUGGESTED LIST PRICES AND ARE SUBJECT TO CHANGE WITHOUT NOTICE
*PARTS USED ON PREVIOUS RECEIVERS

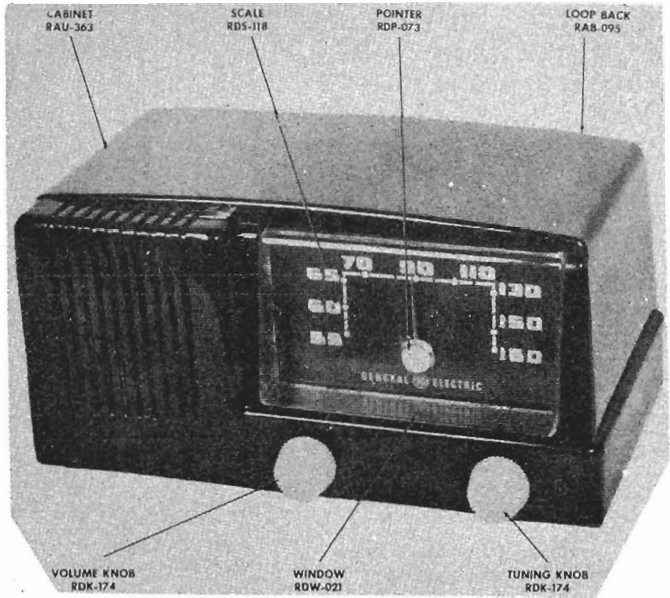

SPECIFICATIONS

CABINET:

Color Black
 Height 6 7/8 in.
 Width 12 1/2 in.
 Depth 7 1/4 in.

ELECTRICAL RATING:

Voltage 105-125, 50-60 cycles or DC
 Watts 26

OPERATING FREQUENCIES:

Standard Wave Band 540-1600 KC
 I-F Amplifier 455 KC

POWER OUTPUT:

Undistorted 1 watt
 Maximum 1.75 watts

LOUDSPEAKER:

Type Alnico PM
 Outside Cone Diameter 4 inches
 Voice Coil Impedance @ 400 cycles 3.2 ohms

TUBE COMPLEMENT:

V1 Oscillator-Converter 12BE6
 V2 I-F Amplifier 12BA6
 V3 Detector-Audio 12AV6
 V4 Rectifier 35W4
 V5 Audio Power Amplifier 50C5
 I1 Dial Light G. E. Mazda No. 47

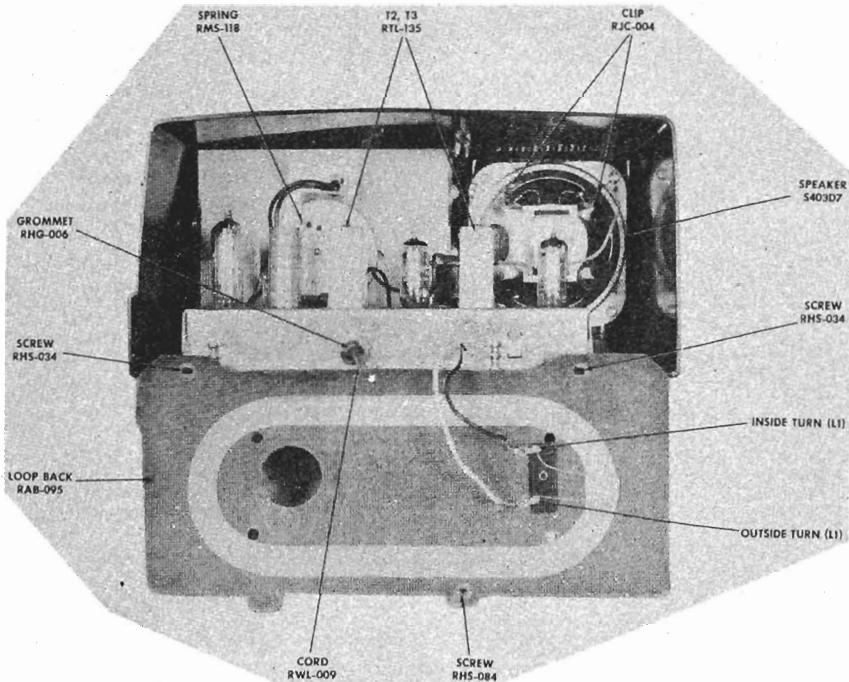

MODEL 412

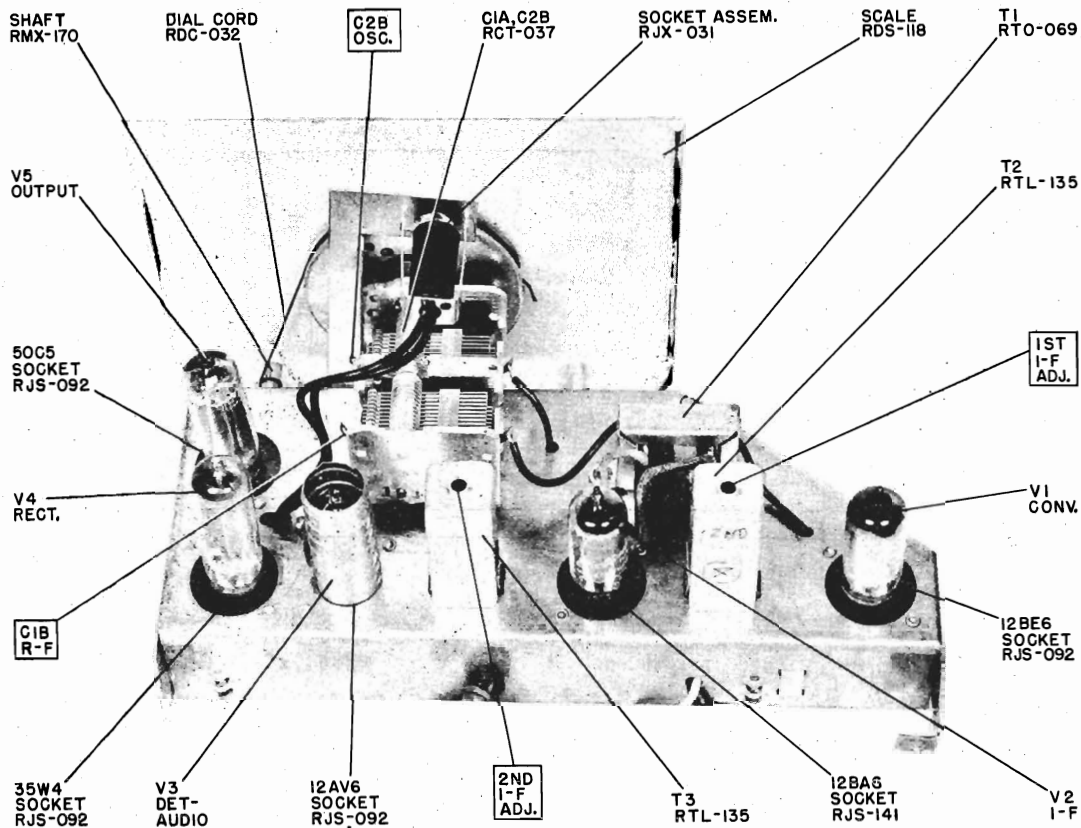

Chassis, Top View

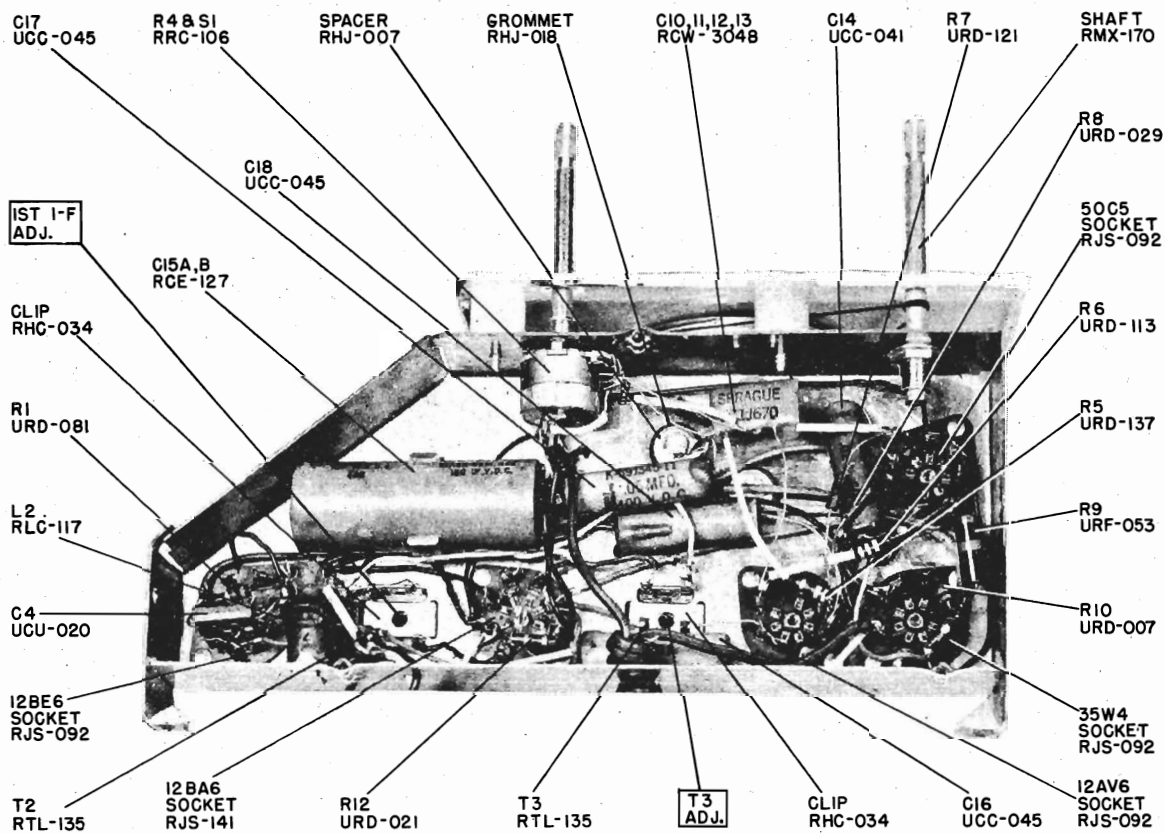

Chassis, Bottom View

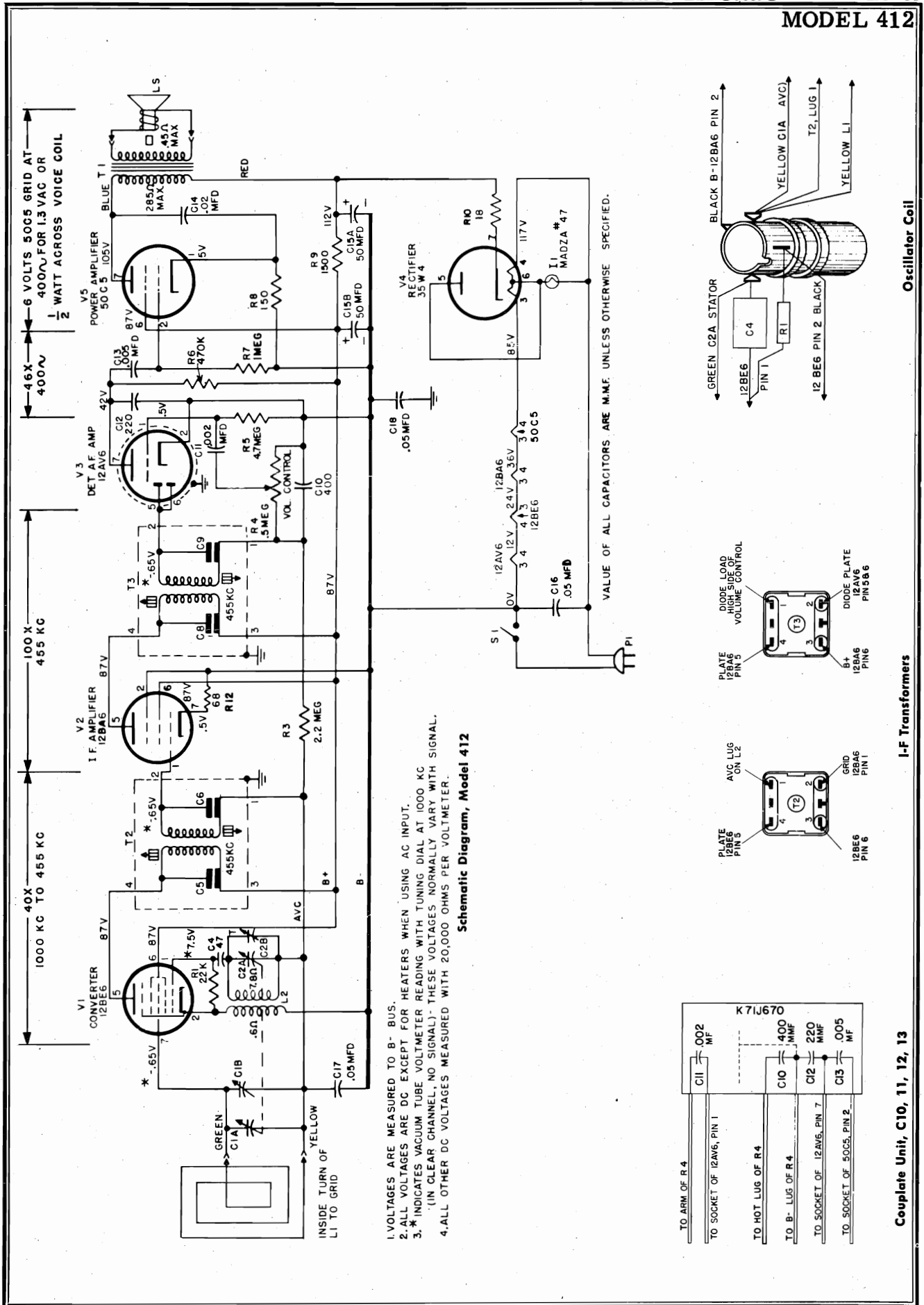

Schematic Diagram, Model 412

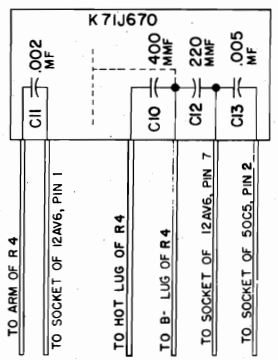

Couplate Unit, C10, 11, 12, 13

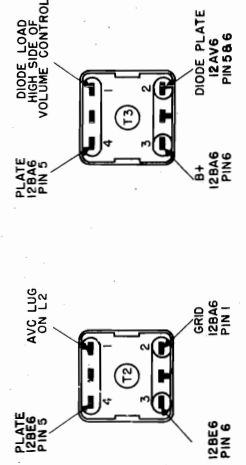

I-F Transformers

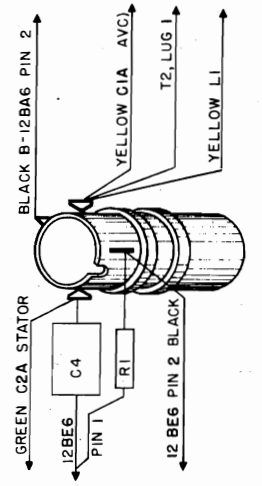

Oscillator Coil

MODEL 412

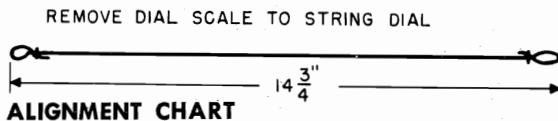

Always have volume control set for maximum and reduce signal input so AVC will not affect output.

Step	Connect Test Oscillator to	Test Osc. Setting	Radio Dial Setting	Adjust for Maximum
I-F ALIGNMENT				
1	V2, 12BA6 grid (Pin 1) in series with .05 mfd.	455 kc		Cores of second I-F transformer, T3
2				Cores of first I-F transformer, T2
3	V1, 12BE6 grid (Pin 7) in series with .05 mfd.			Recheck adjustment of T2 and T3, for max.
R-F ALIGNMENT				
4	Inductively coupled to radio loop	1620 kc	Minimum capacity C1A, C2A	C2B oscillator trimmer
5		1500 kc	For Maximum	C1B, R-F trimmer
6	Set pointer to 150.			

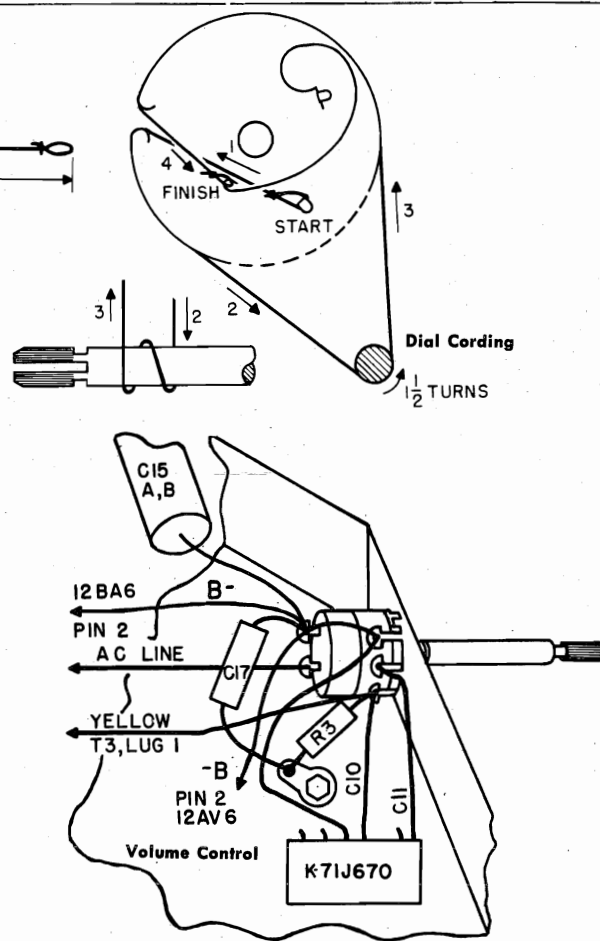

PARTS LIST FOR MODEL 412

Cat. No.	Symbol	Description	Unit Price	Cat. No.	Symbol	Description	Unit Price
CAPACITORS				MISCELLANEOUS ELECTRICAL			
*RCE-127	C15A, B	50 mf., 150 v.; 50 mf., 150 v., electrolytic	\$1.85	*RJC-004		CONNECTOR—Speaker connector clip on audio output leads	\$0.02
*RCT-037	C1A, B; C2A, B	Two gang, osc., 10.6-126 mmf., r-f 14.3-420 mmf., with drive drum and trimmers	3.60	*RJS-092		SOCKET—Miniature wafer, seven pin wax impregnated, 1 5/16 in. mounting centers; for tubes 12BE6, 12AV6, 50C5, 35W4	.20
*RCW-3048	C10, 11, 12, 13	400 mmf., .002 mf., 220 mmf., .005 mf., 450 v., ceramic	.90	*RJS-141		SOCKET—Miniature wafer, seven pin, 1 5/16 in. mounting centers; for tube 12BA6	.20
*UCC-041	C14	.02 mf., 600 v. paper	.25	*RJX-031		SOCKET—Bayonet type for Mazda #47 dial lamp; with clip-on bracket.	.40
*UCC-045	C16, 17, 18	.05 mf., 600 v., paper	.30	*RWL-009		POWER CORD—AC cord and plug, brown	.70
*UCU-020	C4	47 mmf., 500 v., mica	.25	*S403D7		LOUDSPEAKER—4 in. PM, 4 watt	4.30
RESISTORS (CARBON)				MISCELLANEOUS MECHANICAL			
*URD-007	R10	18 ohms 1/2 w.	\$0.13	*RDC-032		CORD—Dial cord, bulk quantity 25 yds	\$2.50
*URD-021	R12	68 ohms 1/2 w.	.13	*RDK-174		KNOB—Off-volume or tuning control knob, color buff	.15
*URD-029	R8	150 ohms 1/2 w.	.13	RDP-073		DIAL POINTER—Dial pointer, metal, brass finish	.40
*URD-081	R1	22,000 ohms 1/2 w.	.13	RDS-118		DIAL SCALE—Dial scale and back-plate, plastic, ivory, translucent numerals	1.05
*URD-113	R6, 11	470,000 ohms 1/2 w.	.13	*RHC-024		CLIP—1/2 in. clip mounts C15A, B	.10
*URD-121	R72	1 megohm 1/2 w.	.13	*RHC-034		CLIP—For mounting I-F transformers	.05
*URD-129	R3	2.2 megohms 1/2 w.	.13	*RHG-006		GROMMET—For 110 v. line cord	.05
*URD-137	R5	4.7 megohms, 1/2 w.	.13	*RHG-018		GROMMET—Rubber shock mount for tuning capacitor	.05
*URF-053	R9	1500 ohms, 2 w.	.25	*RHJ-007		SPACER—In grommet, RHG-018, mounting tuning capacitor	.05
POTENTIOMETER				*RMC-002		CLIP—Osc., coil mtg. clip	.05
*RRC-106	R4, S1	500K ohms, composition, volume control and on-off switch.	\$1.65	*RMS-118		SPRING—Dial cord tension spring	.10
COILS AND TRANSFORMERS				*RMX-170		SHAFT—Tuning shaft and bushing assembly	.35
*RLC-117	L2	COIL—For oscillator V1	\$0.90	CABINETS AND CABINET PARTS			
RTL-135	T2, C5, C6, T3, C8, C9	TRANSFORMER—1st or 2nd I-F, 455KC	1.90	*RAB-095		BACK—Includes antenna loop, L1	\$1.55
*RTO-069	T1	TRANSFORMER—Audio output	1.75	*RAU-363		CABINET—Plastic, black	6.25
				*RDW-021		DIAL WINDOW—Plastic, 6 1/2 x 3 1/2 inches	.60

*Parts used on previous receivers.

PRICES ARE SUBJECT TO CHANGE WITHOUT NOTICE.

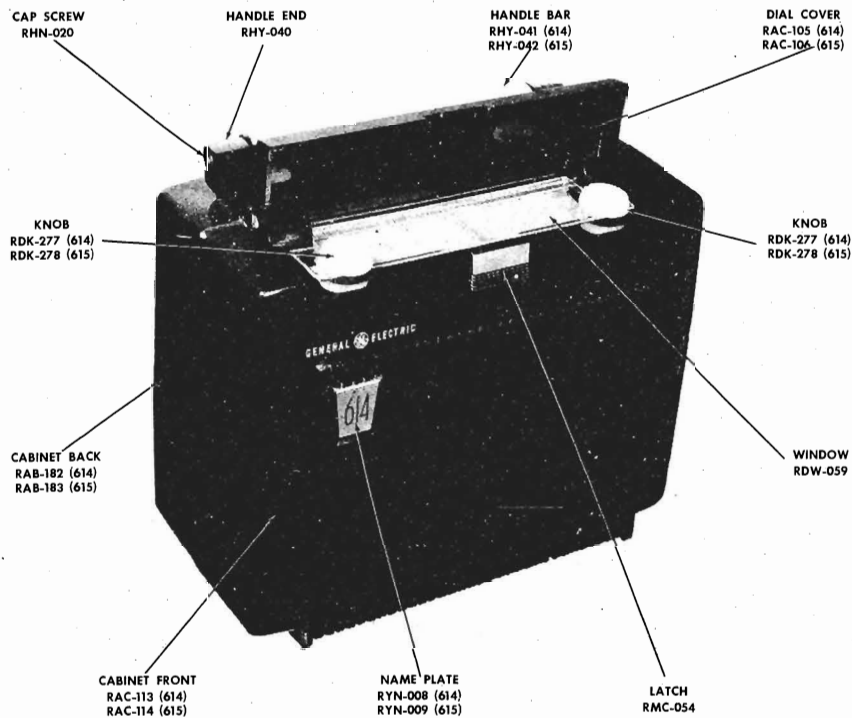

9-194R

SPECIFICATIONS

CABINET:

Model 614	Maroon, plastic
Model 615	Green, plastic
Height	10 3/4 inches
Length	11 3/8 inches
Width	5 3/4 inches

TUBE COMPLEMENT:

V1	R-F amplifier	1T4
V2	Oscillator-Converter	1R5
V3	I-F amplifier	1T4
V4	Detector and 1st audio	1U5
V5	Power amplifier	3V4

POWER SUPPLY:

Power line	105-120 volts, D-c or 60 cps A-c
Battery	AB combination 9 and 90 volts Eveready 753 Bright Star 66-50 Burgess F6A60 Rayovac AB994
Power Consumption (connected to power line)	25 watts

BOTTOM SHIELD REMOVAL:

For most services to the chassis such as i-f alignment, voltage measurement and component replacement it is not necessary to completely remove the radio from the cabinet. To gain access to the inside of the chassis to perform these services it is only necessary to remove the chassis bottom shield as follows:

1. Remove the hex head screw in cabinet bosses at each side of chassis.
2. Remove the three snap fasteners holding shield to back edge of chassis.
3. Remove the hex head screw holding bottom shield to each end of chassis.
4. Withdraw shield to position exposing chassis components.

OPERATING FREQUENCIES:

Broadcast	540-1600 kc
I-F Amplifier	455 kc

POWER OUTPUT:

Undistorted	180 milliwatts
Maximum	250 milliwatts

CHASSIS REMOVAL:

1. Remove the two control knobs.
2. Remove the hex head screw in cabinet bosses at each side of chassis.
3. Remove two hex head screws holding chassis support brackets to bosses in bottom of cabinet.
4. Disconnect audio output leads from loudspeaker and remove complete chassis with brackets.

LOUDSPEAKER:

Type	Alnico PM
Cone Size	Oval, 4 inches x 6 inches
Voice coil impedance @ 400 cycles	3.2 ohms

MODELS 614, 615

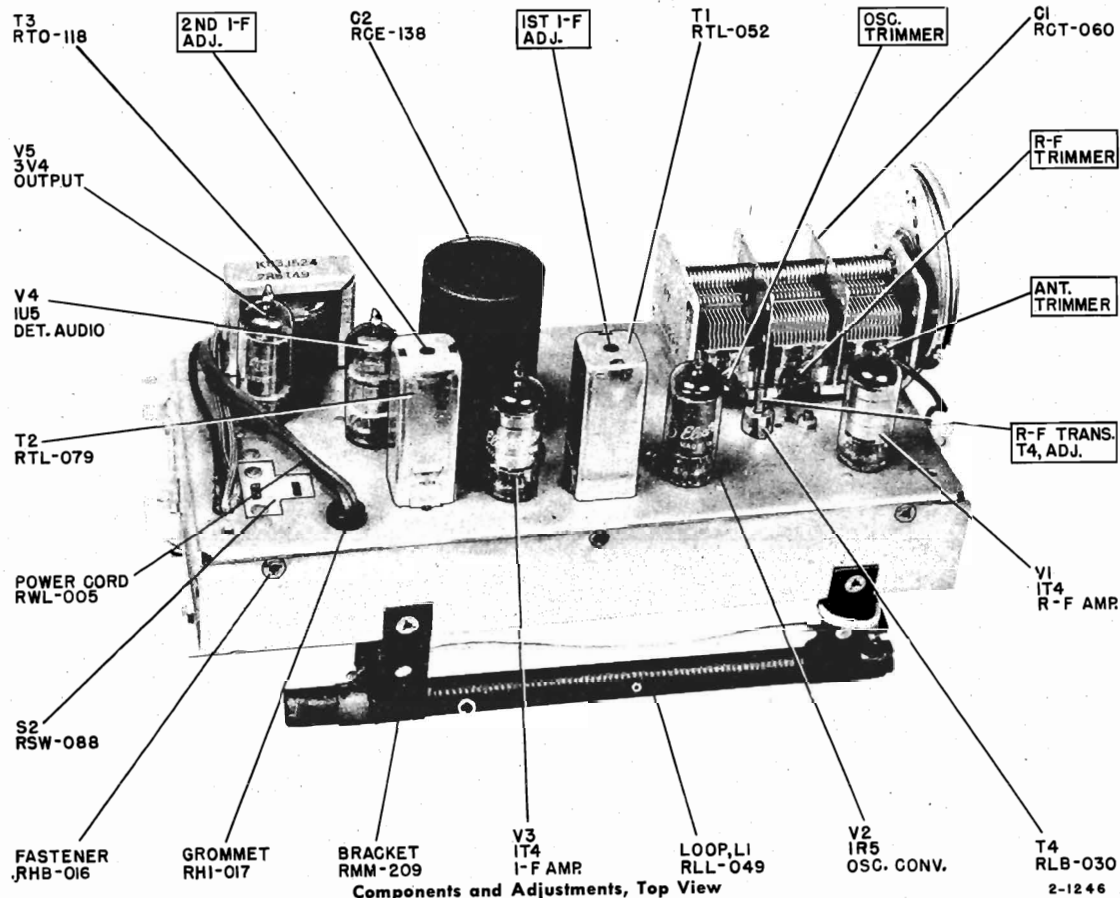

Components and Adjustments, Top View

2-1246

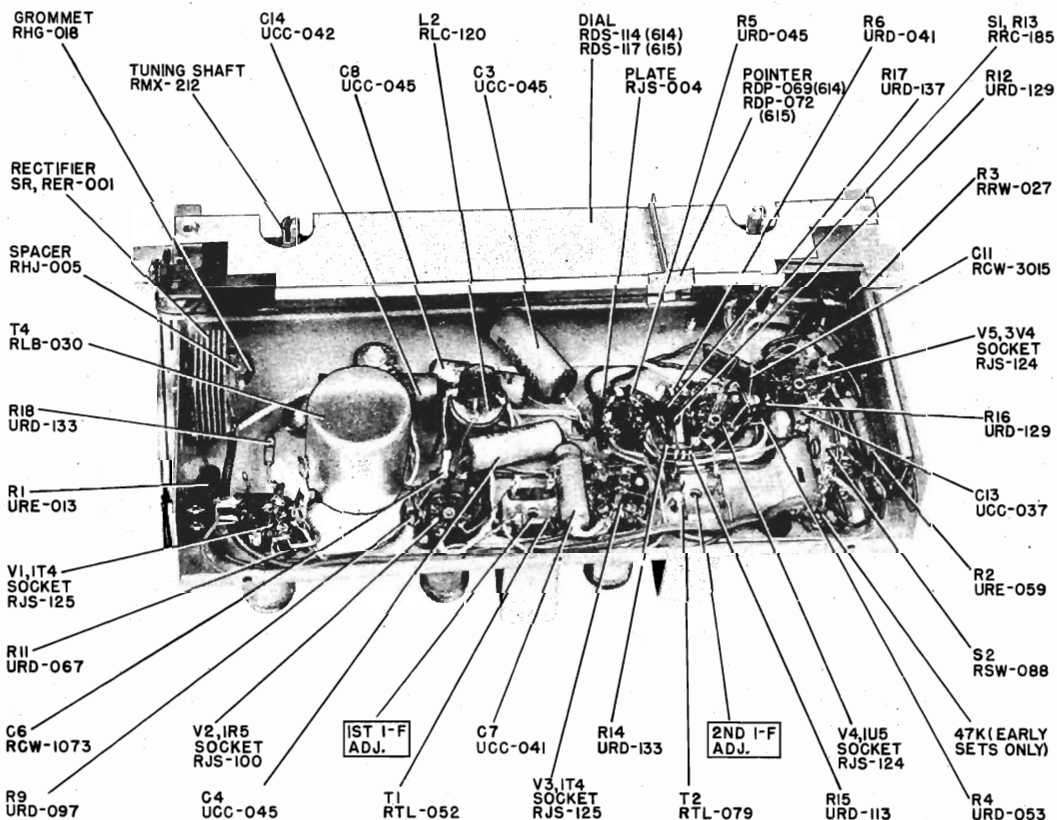

Components and Adjustments, Bottom View

2-1249

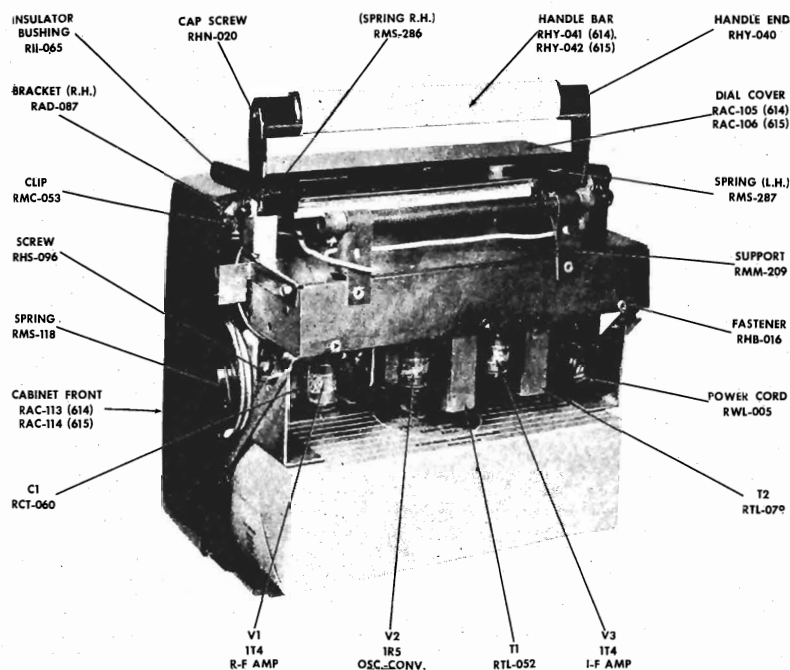

ALIGNMENT CHART

Always have volume control full on and reduce signal input so A-V-C will not affect output.

Step	Test-oscillator Connected to	Test Osc. Setting	Pointer Setting	Adjust for Maximum Output
1	1T4 (V3) I-F grid (pin 6) in series with .05 mfd. and B- bus.	455 KC	550 KC	Iron cores of 2nd I-F Transformer, T2.
2	1R5 (V2) converter grid (pin 6) in series with .05 mfd. and B- bus.	455 KC	550 KC	Iron cores of 1st I-F Transformer, T1.
3	1T4 (V1) R-F amplifier grid (pin 6) in series with .05 mfd. and B- bus.	1670 KC	Gang condenser (C1A, B, C) fully open	C1B oscillator trimmer.
4		1500 KC	For max. output	C1C R-F trimmer.
5		580 KC	For max. output	Core of T4.
6	Repeat steps 4 and 5 to give maximum output.			
7	Inductively coupled to loop, L1	1500 KC	For max. output	C1A antenna trimmer.

Cat. No.	Symbol	Description	Unit Price
CAPACITORS			
RCE-138	C2A, B, C, D	40 mfd.-40 mfd., 150v.; 200 mfd.-100 mfd., 25 v.	\$4.50
RCT-060	C1A, B, C	Tuning capacitor, 3 gang	5.75
*RCW-1073	C6	47. mmf., 10% temp. coeff., ceramic60
*RCW-3015	C11A, B, C, D, E	.002 mf., 220 mmf., 220 mmf., .005 mf., .005 mf., ceramic couplate (late receivers use C12, UCU-036, in lieu of section C11E) ..	1.10
*UCC-037	C13	.003 mf., 600 v., paper25
*UCC-041	C7	.02 mf., 600 v., paper25
*UCC-042	C14	.03 mf., 600 v., paper30
*UCC-045	C3, 4, 8	.05 mf., 600 v., paper30
*UCU-036	C12	220 mmf., 500 v., mica used in late prod. in lieu of RCW-3015, C11, section E.30
RESISTORS (Carbon)			
*URD-041	R6	470 ohms, 1/2 w.13
*URD-045	R5	680 ohms, 1/2 w.13
*URD-053	R4	1500 ohms, 1/2 w.13
*URD-067	R11	5600 ohms, 1/2 w.13
*URD-097	R9	100 K ohms, 1/2 w.13
*URD-113	R15	470 K ohms, 1/2 w.13
*URD-129	R12, 16	2.2 megohms, 1/2 w.13
*URD-133	R14, 18	3.3 megohms, 1/2 w.13
*URD-137	R17	4.7 megohms, 1/2 w.13
*URE-013	R1	33 ohms, 1 w.17
*URE-059	R2	2700 ohms, 1 w.17

MODELS 614, 615

PARTS LIST

(Potentiometers and Wirewound)			
RCC-185	R13, S1	Volume control, 500K ohms, with DPST switch.....	1.70
*RRW-027	R3	2300 ohms, 10 w., w.w.....	1.00

COILS AND TRANSFORMERS			
*RLB-030	T4	TRANSFORMER—R-F.....	1.95
RLC-120	L2	COIL—Oscillator coil.....	.90
RLL-049	L1	COIL—Antenna pickup coil wound on ferrite core.....	1.50
*RTL-052	T1	TRANSFORMER—1st I-F.....	2.75
*RTL-079	T2	TRANSFORMER—2nd I-F.....	2.75
RTO-118	T3	TRANSFORMER—Audio output.....	2.85

MISCELLANEOUS ELECTRICAL			
*RER-001	SR	SELENIUM RECTIFIER—75 ma., 6 plates, 1 in. x 1 in.....	.66
RII-070	S2	PLATE—Textolite mtg. plate for line battery changeover switch, S2.....	.05
*RJP-025	PL1	PLUG—Four prong battery plug with locating pin.....	.15
*RJS-100		SOCKET—Miniature wafer, seven pin, wax impregnated, one inch mtg. centers for tube 1R5 (V2).....	.20
*RJS-124		SOCKET—Miniature wafer, seven pin, one inch mtg. centers; for tubes 1U5, 3V4 (V4 or V5).....	.20
*RJS-125		SOCKET—Miniature wafer, seven pin, with pin shield post, one inch mtg. centers for tubes 1T4 (V1 or V3).....	.20
ROP-024	LS1	LOUDSPEAKER—Oval, 4 x 6 inch, PM, 2 watt, 3.2 ohms at 400 cycles.....	7.95
*RSW-088	S2	SWITCH—Line battery changeover switch, power plug operated, wafer type.....	1.75
*RWL-005		CORD—Power cord and plug, 6 feet long.....	1.25

MISCELLANEOUS MECHANICAL			
*RDC-032		CORD—Dial cord, bulk quantity, 25 yards.....	\$2.50
RDP-069		DIAL POINTER—Metal slider and red plastic flag; for Model 614.....	.25
RDP-072		DIAL POINTER—Metal slider and gold finished plastic flag; for Model 615.....	.25
RDS-114		DIAL SCALE—Scale and backplate, green background; for Model 614.....	.95
RDS-117		DIAL SCALE—Scale and backplate, gold finish background; for Model 615.....	.95
*RHB-016		FASTENER—Snap fastener, Trimount type; for chassis cover.....	.05
*RHG-018		GROMMET—Rubber grommet for tuning capacitor shock mounting.....	.05
*RHI-017		GROMMET—Two piece strain relief insulator for power cord.....	.15
*RHJ-005		SPACER—Metal spacer bushing for mounting tuning capacitor.....	.02
*RHN-020		CAP SCREW—No. 6-32 tap, Phillips head, for handle ends.....	.10
RHS-094		SCREW—No. 6-32 threaded rod 8½ inches long; through handle bar to handle ends..	.40
RHS-096		SCREW—Thumbscrew on battery hold-down bracket.....	.10
RHY-040		HANDLE END—Metal casting, chrome finish.....	1.40
RHY-041		HANDLE BAR—Hand grip, plastic, ivory; for Model 614.....	.75
RHY-042		HANDLE BAR—Hand grip, plastic, green; for Model 615.....	.75

Cat. No.	Symbol	Description	Unit Price
*RII-065		INSULATOR BUSHING—For handle bracket on chassis.....	.10
*RJS-004		MOUNTING PLATE—For electrolytic capacitor, C2.....	.10
*RMC-002		CLIP—Coil clip for ½ inch diameter oscillator coil, L2.....	.05
RMM-206		CORK—On battery hold-down bracket.....	.05
RMM-209		SUPPORT—Formed paper antenna loop support.....	.03
*RMS-118		SPRING—Dial cord tension spring.....	.10
RMX-212		SHAFT—Tuning control shaft and bushing assembly.....	.90

CABINET AND CABINET PARTS			
RAB-182		CABINET BACK—Back half of cabinet, maroon, plastic; for Model 614; includes ½ slip hinge.....	3.90
RAB-183		CABINET BACK—Back half of cabinet, green plastic; for Model 615; includes ½ slip hinge.....	3.90
RAC-105		COVER—Dial cover, maroon, plastic; for Model 614.....	1.45
RAC-106		COVER—Dial cover, green, plastic; for Model 615.....	1.40
RAC-113		CABINET FRONT—Front half of cabinet, maroon, plastic; includes ½ slip hinge and Model 614 nameplate.....	7.95
RAC-114		CABINET FRONT—Front half of cabinet, green, plastic; includes ½ slip hinge and Model 615 nameplate.....	7.95
RAD-087		BRACKET—Dial cover hinge bracket, right-hand.....	.20
RAD-088		BRACKET—Dial cover hinge bracket, left-hand.....	.20
RAG-046		GRILLE CLOTH—Maroon, pasteboard mounted assembly, for Model 614.....	.45
RAG-047		GRILLE CLOTH—Green, pasteboard mounted assembly, for Model 615.....	.45
RAX-029		LATCH BRACKET—For dial cover, includes latch spring.....	.15
RDK-277		KNOB—Volume or tuning control, ivory; for Model 614.....	.15
RDK-278		KNOB—Volume or tuning control, green; for Model 615.....	\$0.15
RDW-059		WINDOW—Dial scale window, plastic.....	.60
*RHE-010		EYELET—Cabinet catch, held by screw RHS-097 to cab. back cover.....	.05
RHI-023		HINGE—Cabinet slip hinge in two parts.....	.30
RHS-097		SCREW—Screw No. 6 x ½ inch, Phillips round head; holds eyelet used as cabinet catch.....	.02
*RMC-053		CLIP—Latch clip on front half of cabinet engages eyelet, RHE-010, to close cabinet.....	\$0.05
RMC-054		LATCH—Chrome finish metal, for dial cover.....	.90
RMP-033		ROD—Pivot rod for dial cover latch, RMC-054.....	.10
RMS-286		SPRING—Coil spring for dial cover hinge (right-hand).....	.05
RMS-287		SPRING—Coil spring for dial cover hinge (left-hand).....	.05
RYN-008		NAMEPLATE—Model 614 nameplate.....	.40
RYN-009		NAMEPLATE—Model 615 nameplate.....	.40

PRICES ARE SUGGESTED LIST PRICES AND SUBJECT TO CHANGE WITHOUT NOTICE.

*Parts used on previous receivers.

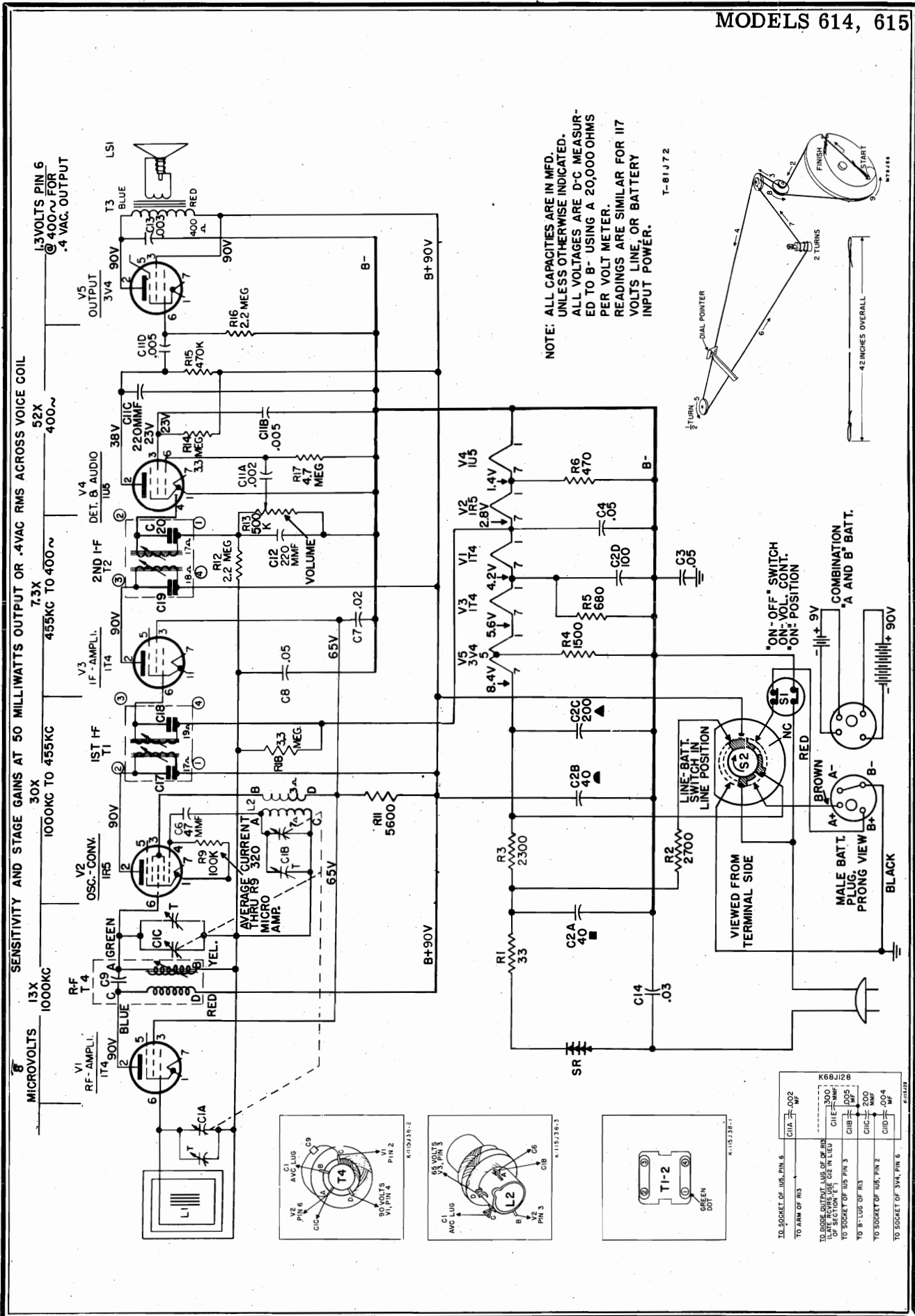

MODELS 514,
542, 543

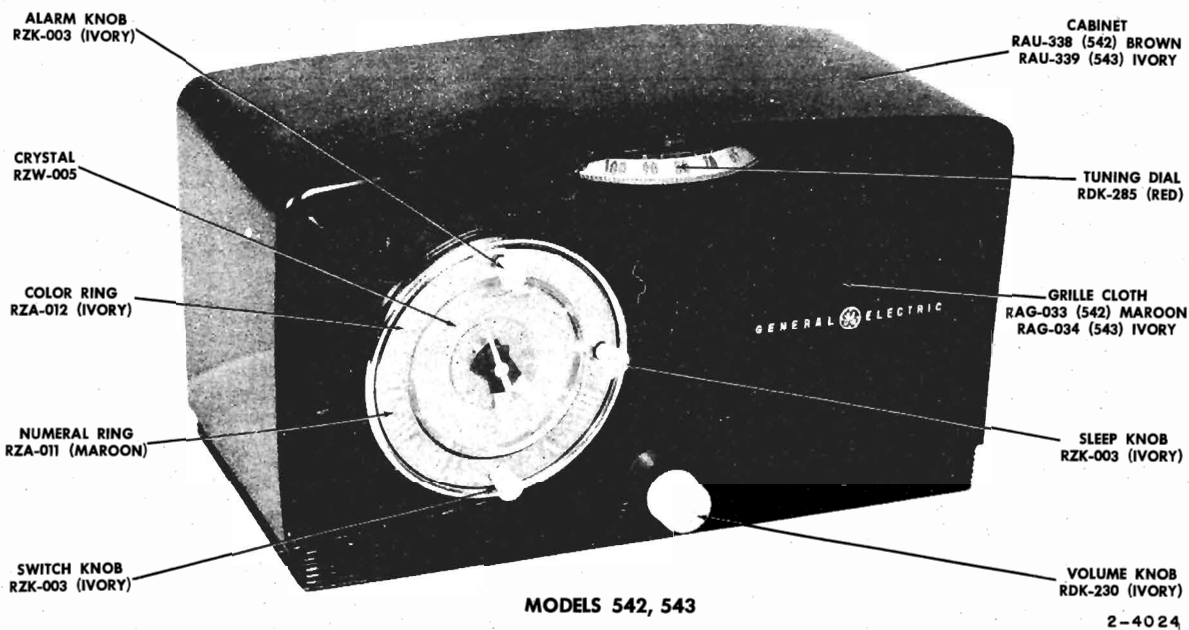
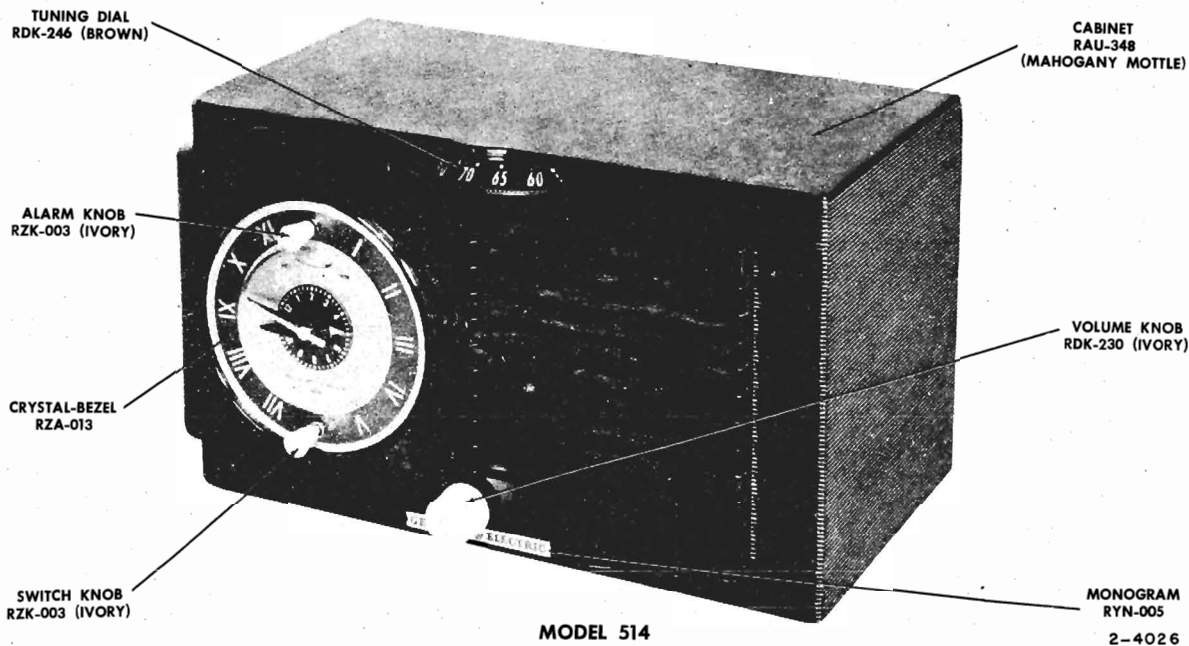

ER-5-514

MODELS 514,
542, 543

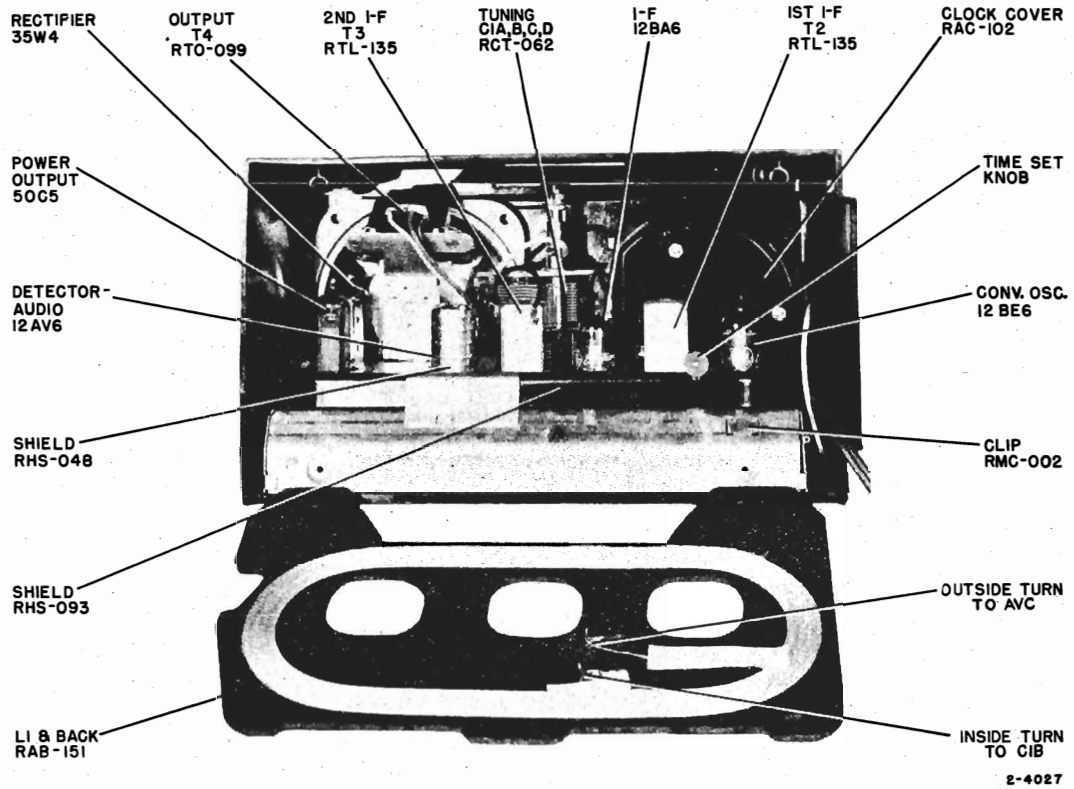

Fig. 1. Identification of Components, Model 514, Rear view

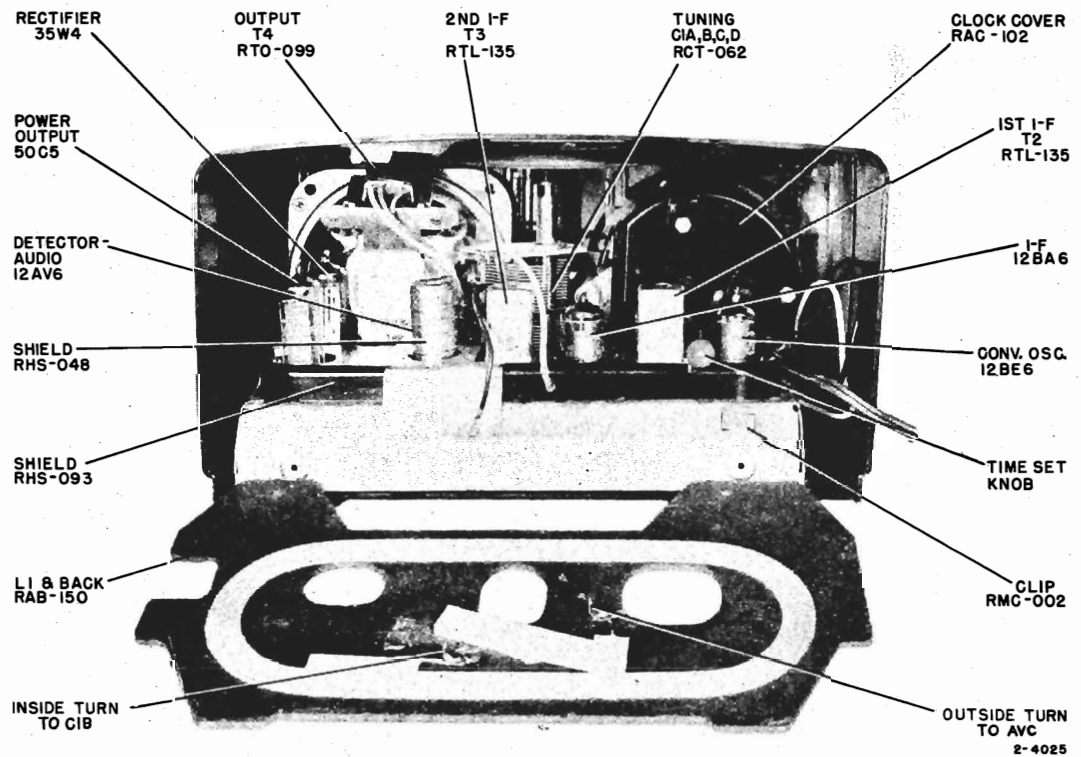

Fig. 2. Identification of Components, Models 542 and 543, Rear view

MODELS 514,
542, 543

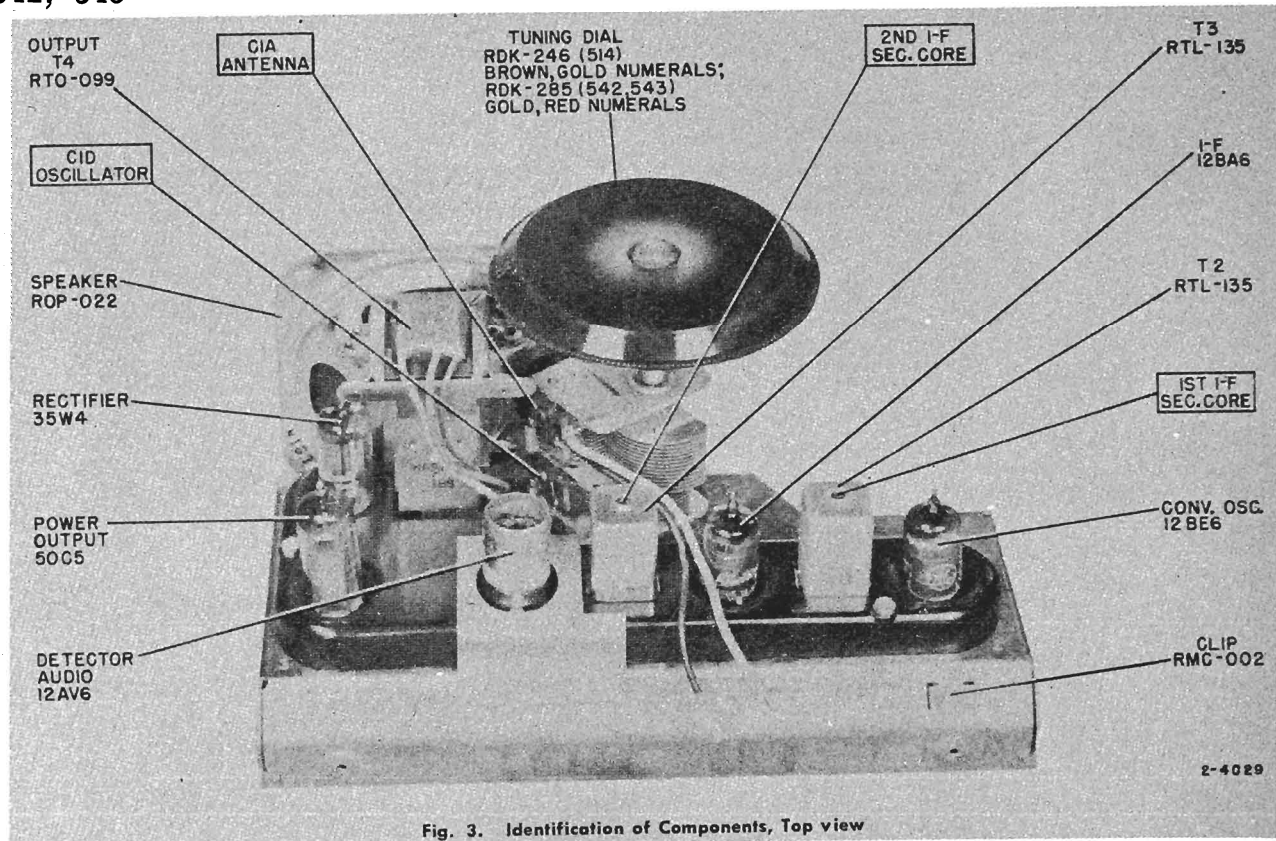

Fig. 3. Identification of Components, Top view

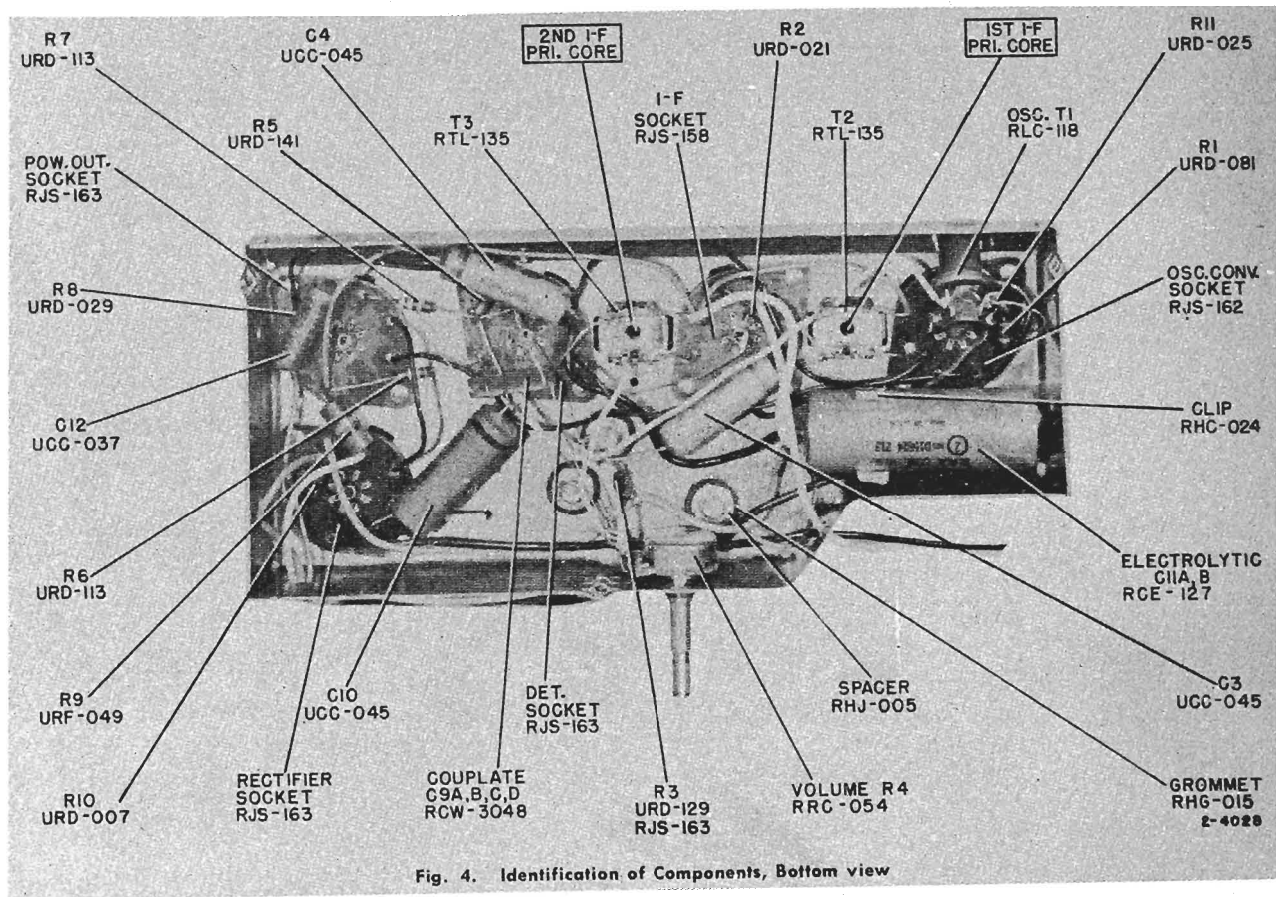

Fig. 4. Identification of Components, Bottom view

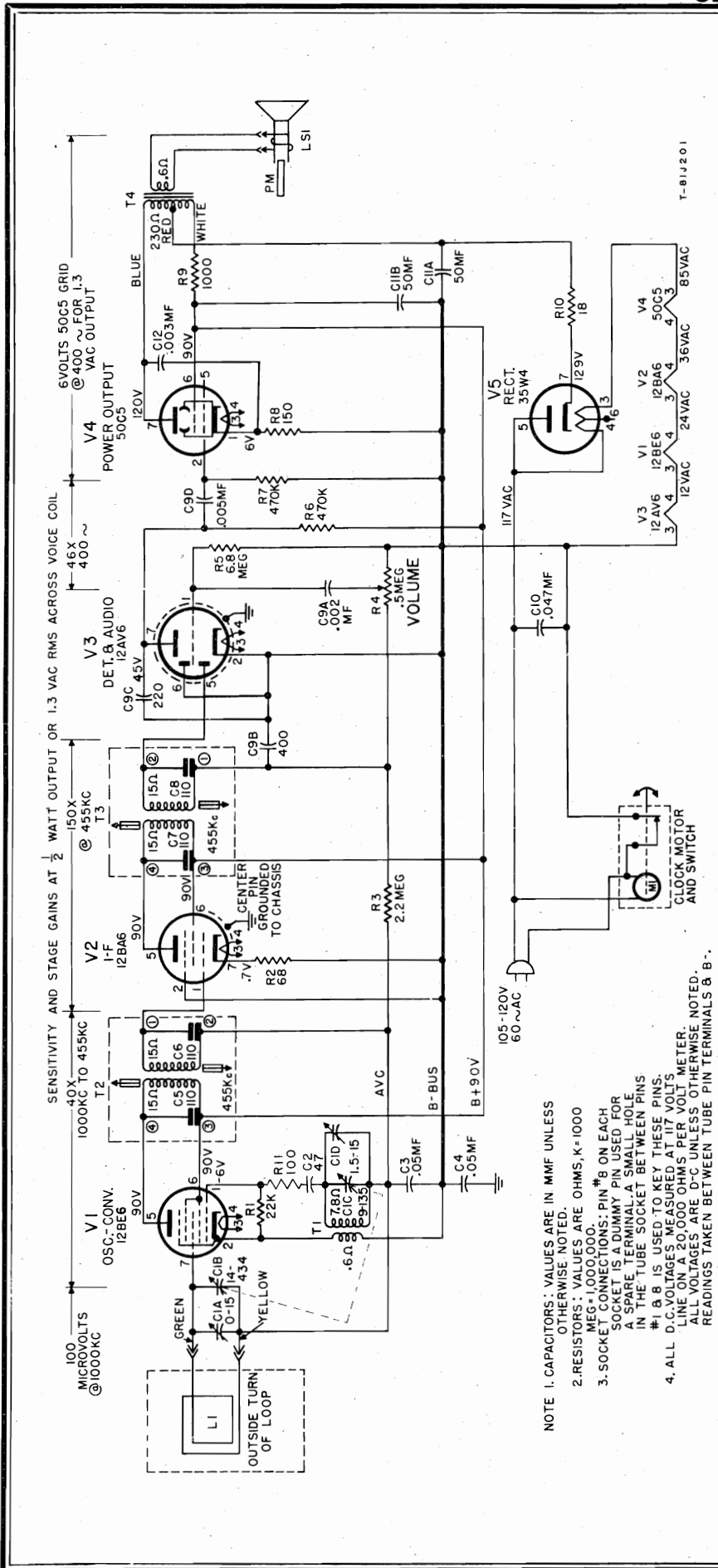

Fig. 5. Schematic Diagram, Models 514, 542 and 543

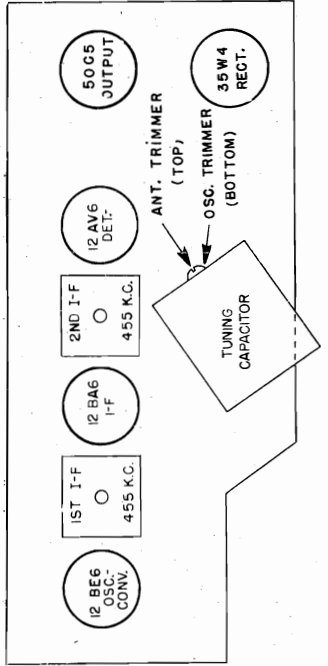

Fig. 6. Location of Tubes and Adjustments

MODELS 514,
542, 543

SPECIFICATIONS

OVER-ALL CABINET DIMENSIONS	MODEL	514	542	543
Color		Mahogany Mottle	Brown Mottle	Ivory
Height		6 1/4 in.	6 3/8 in.	6 3/8 in.
Width		10 3/8 in.	11 3/8 in.	11 3/8 in.
* Depth		6 1/4 in.	6 1/4 in.	6 1/4 in.

* Including knobs

ELECTRICAL RATING	Voltage	105-120
	Frequency	60 cycles only
	Watts	30
OPERATING FREQUENCIES	Standard Broadcast	540-1600 kc
	I-F Amplifier	455 kc
POWER OUTPUT	Undistorted	1 watt
	Maximum	1.75 watts
LOUDSPEAKER	Type	Alnico PM
	Outside Cone Diameter	4 inches
	Voice Coil Impedance @ 400 cycles	3.5 ohms
TUBE COMPLEMENT	Purpose	Type
	V1 Oscillator-Converter	12BE6
	V2 I-F Amplifier	12BA6
	V3 Detector—1st Audio	12AV6
	V4 Audio Output	50C5
	V5 Rectifier	35W4

PRODUCTION CHANGES—Two versions of the Models 514, 542 and 543 are noted in the tube socket construction, involving production methods.

MECHANIZED CHASSIS—Mechanized production uses sockets of the dip solder construction. In this operation components and wires are placed into tube pin connections of each socket. The chassis is inverted and dipped into molten metal, to solder the pins from the top. A plastic cover over the top of the sockets insulates these connections against shock hazard.

NONMECHANIZED CHASSIS—A part of production employed the standard method of the past, in socket wiring. In these chassis, components are wired, crimped and individually soldered to standard socket pin connections. Nonmechanized chassis have the letter "C" rubber stamped on the rear chassis apron for identification.

COMPONENT REPLACEMENT—When servicing mechanized chassis, the time and effort otherwise spent to remove the shield, heat tube pin connections and free the components may be spared. A neater job can be done without the risk of damage to the tube sockets by using the following method in wiring a replacement part.

Clip the defective unit out, leaving enough of its leads attached to the tube socket so an eye loop may be formed in the leads. Each lead of the new component may then be passed through the proper loop, pruned to length, crimped and soldered.

CAUTION: One side of the power line is connected to B—. Avoid any ground connections direct to B—. Use an isolating transformer when making service adjustments with the chassis removed from the cabinet.

GENERAL INFORMATION

The Model 514, 542 and 543 clock-radio receivers employ four tubes, plus rectifier tube, in a superheterodyne circuit. A loop antenna, part of the cabinet back, provides excellent signal pick-up, without the need of an external antenna. Each model has an electric alarm clock which is also connected to automatically turn on the radio as a Musical Alarm. The clocks of receiver Models 542 and 543 have the additional Sleep Control feature to permit one hour of radio operation, or a portion thereof, where upon the control mechanism will automatically shut off the radio.

CIRCUIT ALIGNMENT

Always have volume control at maximum and use the minimum amount of signal input necessary to produce a suitable output response.

ALIGNMENT CHART

Step	Connect Test Oscillator to	Test Osc. Setting	Dial Drum Setting	Adjust for Maximum Output
1	12BA6 grid (1) in series with 0.05 mf. cap.	455 kc	Minimum capacity	Cores of 2nd I-F transformer T3
2	12BE6 grid (7) in series with 0.05 mf. cap	1620 kc		Cores of 1st I-F transformer, T2
3	Inductively coupled to Radio loop	1500 kc	Tune for max.	C1D (oscillator)
4				C1A (antenna)

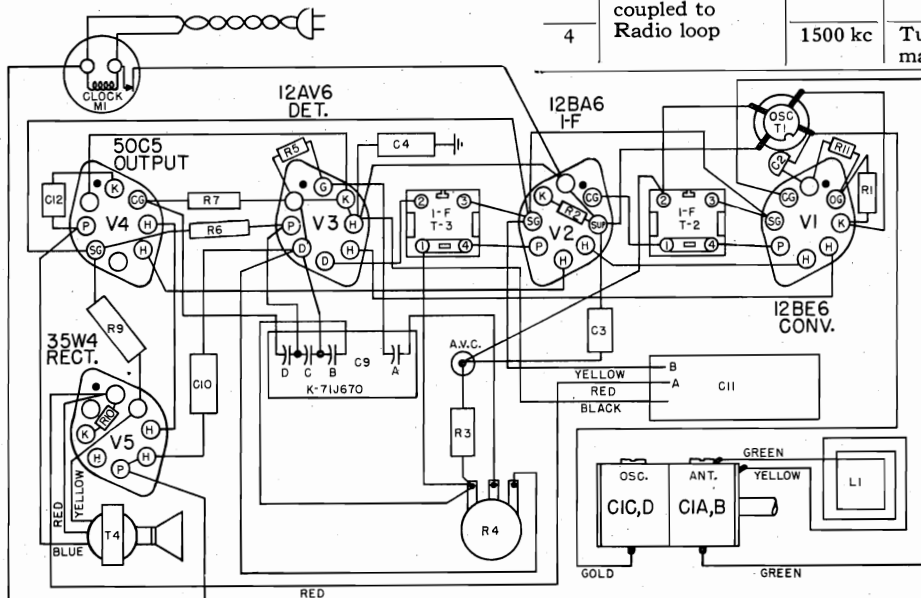

Fig. 7. Wiring Diagram

CLOCK SERVICE

Figures 8, 9 and 10 show clock parts referred to in the following paragraphs and the parts list.

CLOCK MOVEMENT DISASSEMBLY

1. Remove clock movement from case, and pull off knobs.
2. Remove Crystal, Hands and Dial Face.
3. Remove the motor assembly by removing two screws (13) and break two soldered joints on Field. The Field and Rotor Assembly (22 and 23) can now be removed. The Rotor is held by friction only, to the Field.
4. Remove Switch Assembly (4) by removing two screws from base plate.
5. Remove Switch Shaft Assembly (8) and spacer.
6. Remove Alarm-Set Shaft Assembly (31) and spacer.
7. Remove the three front plate assembly screws that are located under the Dial Face and then remove Front Plate.
8. Remove Alarm Gear Sleeve Assembly (17), Hour Gear Sleeve Assembly (18), Minute Gear Sleeve Assembly (19), and Sweep Second Gear Shaft Assembly (20).
9. Remove Alarm Cam Gear Assembly (26) and Spring Washer (25).
10. Remove Intermediate Gear (27).
11. Remove Time-Set Gear and Shaft Assembly (11).
12. Remove Switch Cam Lever (12).

CLOCK MOVEMENT REASSEMBLY

Reassemble in the reverse order of disassembly, observing the following precautions:

1. The spring washer (25) should curve away from the gear when placed on the Alarm Cam Gear Assembly (26).
2. The Switch Cam Lever (12) fork must straddle the base plate post as shown in the illustration.
3. After reassembly of front plate, check, the Sweep Second Gear (20) through the hole in the base plate to make sure it is free to turn.

4. Proceed with Alarm and Switch Adjustments as described below before installing hands.

ALARM AND SWITCH ADJUSTMENTS

1. Turn Switch Knob to Wake-up position.
2. Slowly rotate Time-Set Shaft clockwise until the contacts of the Switch Assembly (4) close.
3. Replace Dial Face, Alarm Dial, the Minute, Hour and Second Hands. Set all Hands and Dial so that they indicate 12 o'clock. Make sure all Hands and Alarm Dial are tight on their respective shafts.
4. With Alarm-Set knob pulled out, continue to rotate Time-Set Shaft clockwise and note that the vibrator arm drops against field core approximately 7-10 minutes later.
5. Set alarm at some other selected position and make sure mechanism actuates within limits (± 1 minute).
6. Check alarm tone of vibrator. This can be adjusted by either bending vibrator arm nearer or farther away from field core. Bend arm near anchor point.

CLEANING AND LUBRICATION

To clean, completely disassemble and clean all moving parts in carbon tetrachloride or some similar cleaner.

The inside of the sleeves and shaft surfaces may be cleaned of oxidized oil by rubbing with a fine grade of steel wool dampened in carbon tetrachloride.

Do not use too much oil and apply by means of a small wire (drop oiler). Too much oil collects dust and later oxidizes. Use only recommended clock oil, such as Nye's Celebrated Oil, which may be purchased from Wm. F. Nye Co., Inc., New Bedford, or an equivalent.

CLOCK TROUBLES

1. Clock will not operate—Defective field coil, defective rotor, binding of parts.
2. Clock loses time—Binding parts, too little friction on minute hand sleeve assembly, defective rotor. Clock time-set shaft bent and rubs against hole in clock bracket.
3. Noisy Clock—Rotor defective, alarm armature improperly adjusted, loose parts, or binding of moving parts.

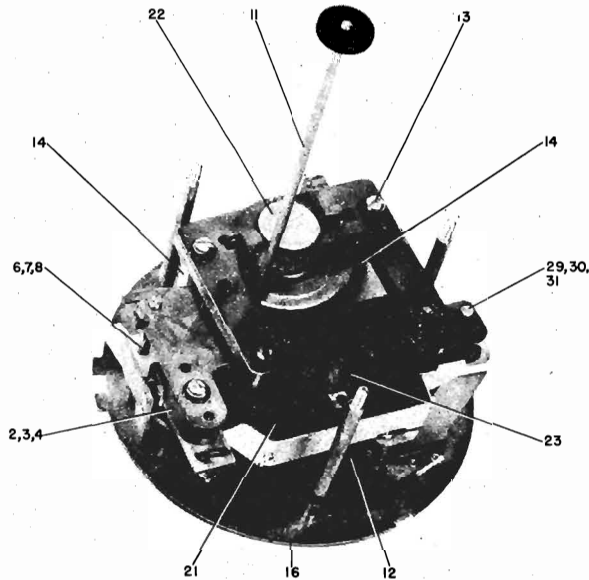

Fig. 8. Back View of C51 Clocks

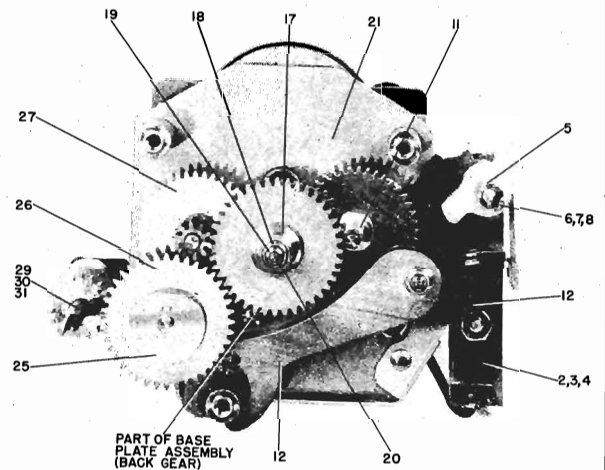

Fig. 9. Front View of C51 Clocks—Front Plate Removed

MODELS 514,
542, 543

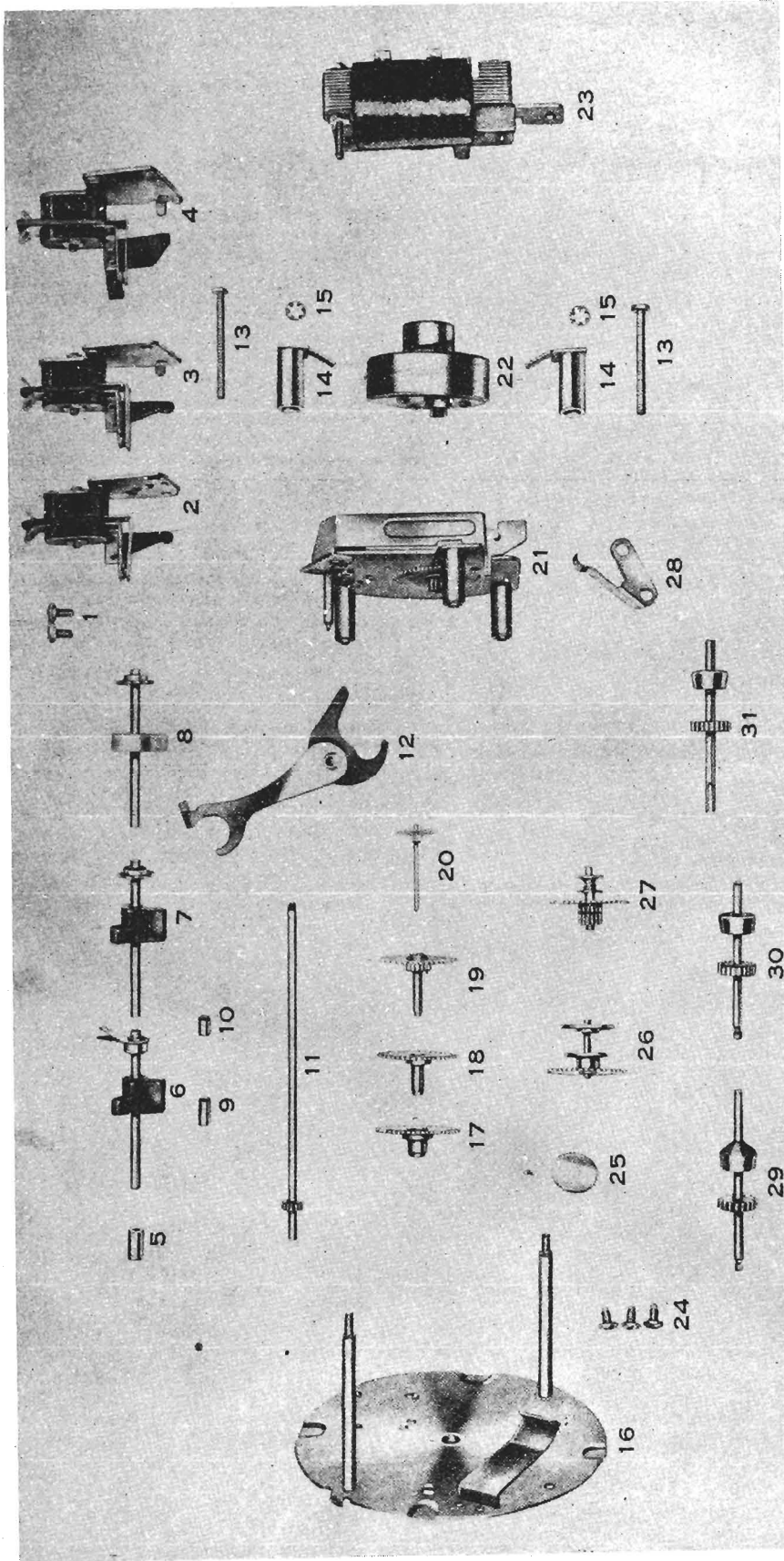

Fig. 10. Exploded View of C51 Clock Movement

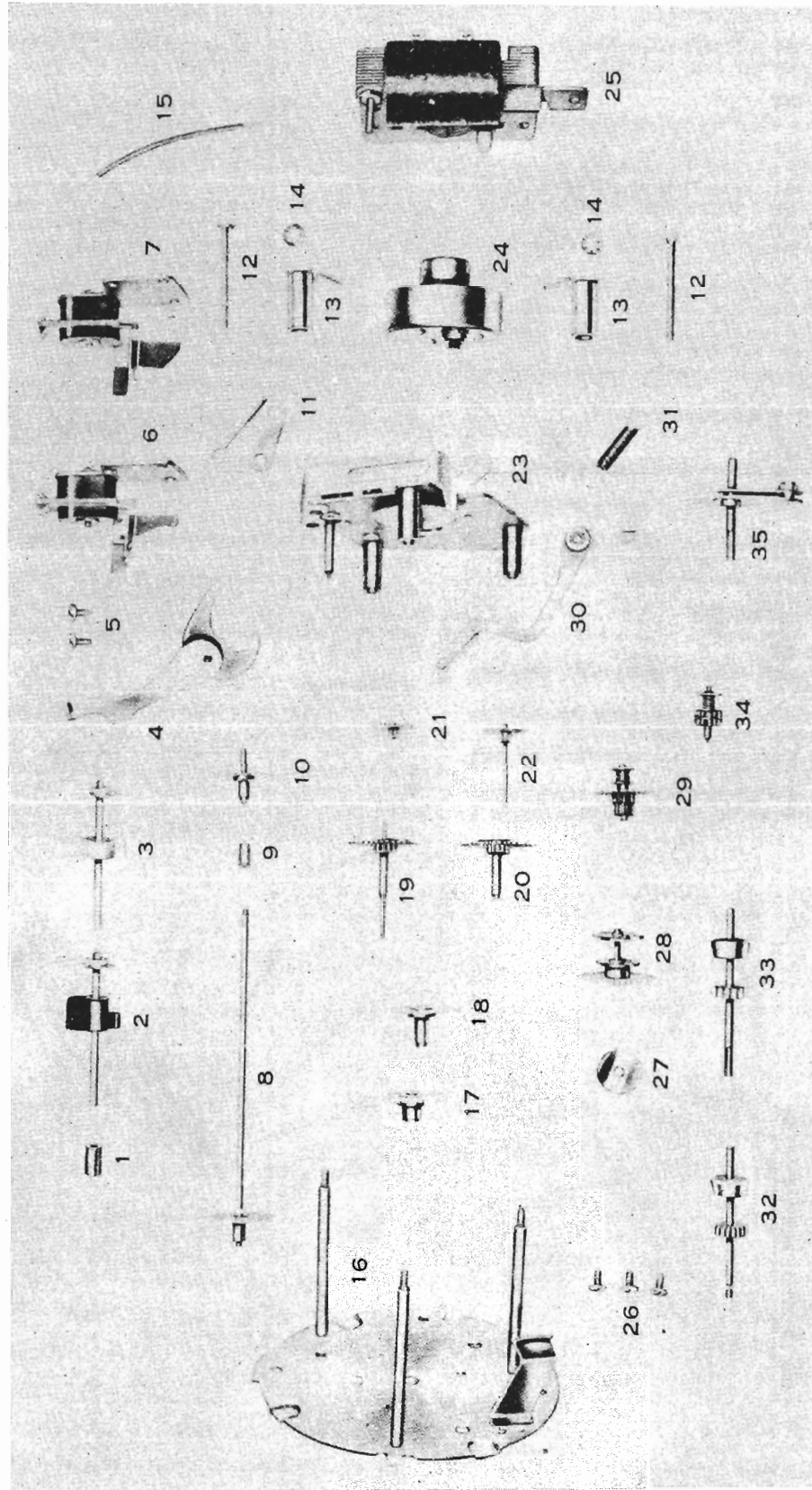

Fig. 13. Exploded View of C57 Series Clock Movement

MODELS 514,
542, 543

CLOCK SERVICE

Figures 11, 12 and 13 show clock parts referred to in the following paragraphs and the parts list.

CLOCK MOVEMENT DISASSEMBLY

1. Remove clock movement from case, and pull off knobs.
2. Remove Bezel, Hands and Dial Face.
3. Remove the motor assembly by removing two screws (12) and break two soldered joints on Field. The Field and Rotor Assembly (25 and 24) can now be removed. The Rotor is held by friction only, to the Field.
4. Remove Switch Assembly by removing two screws (5) from base plate.
5. Remove Switch Shaft Assembly (3) and spacer.
6. Remove Alarm-Set Shaft Assembly (33) and spacer.
7. Remove the three front plate assembly screws that are located under the Dial Face and then remove Front Plate.
8. Remove the following gear assemblies and control levers in the order listed below:
 - (a) Sleep Control Shaft and Segment Gear (35)
 - (b) Alarm Dial Gear (17)
 - (c) Hour Hand Gear (18)
 - (d) Alarm Signal Cam and Gear, and Friction Washer (28, 27)
 - (e) Sleep Control Switch Lever (30)
 - (f) Pinion Drive Gear Assembly (34) (drives Sleep Control Segment Gear)
 - (g) Alarm Control Switch Cam Lever (4)
 - (h) Time Set Shaft and Gear, and Spacer (8, 9)
 - (i) Drive Gear and Pinion Assembly (29)
 - (j) Minute Hand Gear (20)
 - (k) Sweep Second Hand Gear (22)

CLOCK MOVEMENT REASSEMBLY

Reassemble in the reverse order of disassembly, observing the following precautions:

1. The spring washer (27) should curve away from the gear when placed on the Alarm Cam Gear Assembly (28).
2. The Switch Cam Lever fork (4) must straddle the base plate post as shown in the illustration.
3. After reassembly of front plate, check the Sweep Second Gear (22) through the hole in the base plate to make sure it is free to turn.

4. Proceed with Alarm and Switch Adjustments as described below before installing hands.

ALARM AND SWITCH ADJUSTMENTS

1. Turn Wake-Up Manual shaft to WAKE UP position.
2. Slowly rotate Time Set Shaft clockwise until the contacts of the Switch Assembly (7) close.
3. Replace Dial Face, Alarm Dial, the Minute, Hour and Second Hands. Set all Hands so that they indicate 12 o'clock. Set figure 12 of the alarm dial to index with the smaller pointer of the hour hand. Make sure all Hands and Alarm Dial are tight on their respective shafts.
4. With Alarm Set knob pulled out, continue to rotate Time Set Shaft clockwise and note that the Alarm vibrator arm drops against field core approximately 7-10 minutes later.
5. Set alarm at some other selected position and make sure mechanism actuates within limits (± 1 minute).
6. Check alarm tone of vibrator. This can be adjusted by either bending vibrator arm nearer or farther away from field core. Bend arm near anchor point.

CLEANING AND LUBRICATION

To clean, completely disassemble and clean all moving parts in carbon tetrachloride or some similar cleaner. The inside of the sleeves and shaft surfaces may be cleaned of oxidized oil by rubbing with a fine grade of steel wool dampened in carbon tetrachloride. Do not use too much oil and apply by means of a small wire (drop oiler). Too much oil collects dust and later oxidizes. Use only recommended clock oil, such as Nye's Celebrated Oil which may be purchased from Wm. F. Nye Co., Inc., New Bedford, or equivalent.

CLOCK TROUBLES

1. Clock will not operate—Defective field coil, defective rotor, binding of parts.
2. Clock loses time—Binding parts, too little friction on minute hand sleeve assembly, defective rotor. Clock time-set shaft bends and rubs against hole in clock bracket.
3. Noisy Clock—Rotor defective, alarm armature improperly adjusted, loose parts, or binding of moving parts.

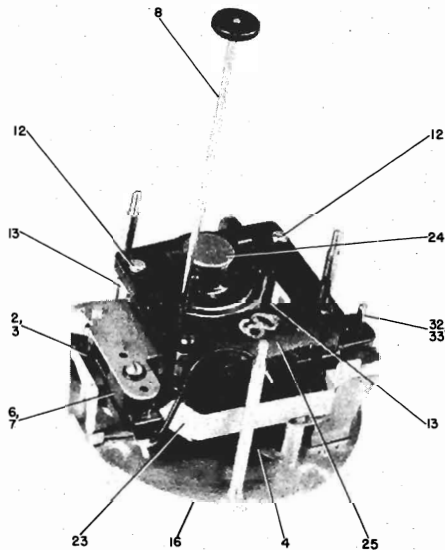

Fig. 11. Back View, C57 Clocks

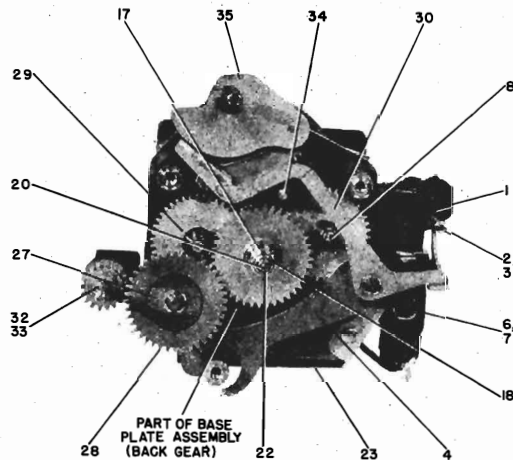

Fig. 12. Front View, C57 Clocks—Front Plate Removed

PARTS LIST FOR MODELS 514, 542 AND 543

Cat. No.	Symbol	Description	Unit Price	Cat. No.	Symbol	Description	Unit Price
CAPACITORS (Paper)				MISCELLANEOUS ELECTRICAL (Cont'd)			
*RCE-127	C11A, B	50-50 mf., 150 v., electrolytic	\$1.85	*RWL-116		CORD—A-c power cord and plug, ivory, for Model 543	\$0.75
RCE-062	C1A, B, C, D	Tuning, two section, 9 mmf.—135 mmf., osc., 14 mmf.—434 mmf., ant.	3.50	RZC-021		CLOCK ASSEMBLY—60 cycles, 105—125 v. for Models 542, 543	17.25
*RCW-3048	C9A, B, C, D	Four ceramic capacitors in two sections— one—.002 mf., section two—400 mmf., 220 mmf., .005 mf.	.90	*RZC-022		CLOCK ASSEMBLY—60 cycles, 105—125 v. for Model 514	13.00
RCW-3075	C2	47 mmf., ceramic	.25	MISCELLANEOUS MECHANICAL			
*UCC-037	C12	.003 mf., 600 v., paper	.25	RAC-102		BRACKET—Clock mounting bracket, plastic	.75
*UCC-045	C3, 4, 10	.05 mf., 600 v., paper	.30	*RDK-230		KNOB—For volume control (ivory)	.15
RESISTORS (Carbon, 1/2 Watt)				*RDK-246		DIAL—Tuning, brown, gold numerals; for Model 514	.60
*URD-007	R10	18 ohms	.13	*RDK-285		DIAL—Tuning, red, for Models 542, 543	.60
*URD-021	R2	68 ohms	.13	*RHC-024		CLIP—For mounting electrolytic capacitor C11	.10
*URD-029	R8	150 ohms	.13	*RHC-034		CLIP—Fastener to hold 1st and 2nd I-F transformer can to chassis	.05
*URD-081	R1	22,000 ohms	.13	*RHG-015		GROMMET—Rubber grommet used to insulate and shock mount tuning cap	.05
*URD-113	R6, 7	470,000 ohms	.13	*RHH-004		FASTENER—Snap on type for holding back to cabinet on Model 514	.02
*URD-129	R3	2.2 meg.	.13	*RHJ-005		SPACER—Metal spacer bushing in grommet mounting tuning capacitor	.02
*URD-141	R5	6.8 megohms	.13	*RHS-075		SCREW—No. 6 self tapping 5/8 in. long, used to hold chassis to cabinet	.02
(Carbon, 2 Watt)				*RHS-085		SHIELD—Metal tube shield for V3, 12AV6 mechanized production, see RHS-110	.15
*URF-049	R9	1000 ohms	.25	*RHS-093		SHIELD—Plastic cover over tube socket pins and terminal board (mechanized production only)	.75
(Potentiometers)				RHS-110		SHIELD—Metal tube shield for V3, 12AV6 nonmechanized production, see RHS-085	
*RRC-054	R4	Volume control 500,000, composition	1.25	RMC-002		CLIP—Oscillator coil mounting	.02
COILS AND TRANSFORMERS				*RMS-214		SPRING—Retaining ring for hub of tuning dial	.05
*RLC-118	T1	COIL—Oscillator coil	.90	CABINETS AND CABINET PARTS			
*RTL-135	T2, 3	TRANSFORMER—1st or 2nd I-F, with tuning cores	1.90	*RAB-150		CABINET BACK—Includes loop antenna, L1, for Models 542, 543	1.25
*RTO-099	T4	TRANSFORMER—Audio output	1.90	*RAB-151		CABINET BACK—Includes loop antenna, L1, for Model 514	1.25
MISCELLANEOUS ELECTRICAL				*RAG-033		CLOTH—Cabinet grille cloth, dark maroon; for Model 542	.30
*RJS-158		SOCKET—Tube socket for V2, 12BA6 mechanized, see RJS-188	.35	*RAG-034		CLOTH—Cabinet grille cloth, ivory; for Model 543	.30
*RJS-162		SOCKET—Tube socket for V1, 12BE6 mechanized, see RJS-189	.30	*RAU-338		CABINET—Brown mottle, plastic; for Model 542	4.95
*RJS-163		SOCKET—Tube socket for V3, V4, V5, 12AV6, 50C5, 35W4 mechanized, see RJS-190	.30	*RAU-339		CABINET—Ivory, plastic; for Model 543	4.95
RJS-188		SOCKET—Tube socket for V2, 12BA6 non-mechanized, see RJS-158		*RAU-348		CABINET—Mahogany mottle, plastic; for Model 514	5.45
RJS-189		SOCKET—Tube socket for V1, 12BE6 non-mechanized, see RJS-162		*RYN-005		NAMEPLATE—G-E monogram for Model 514 cabinet	.20
RJS-190		SOCKET—Tube socket for V3, V4, V5; 12AV6, 50C5, 35W4 nonmechanized, see RJS-163					
*ROP-022		LOUDSPEAKER—4-inch PM	4.90				
*RWL-009		CORD—A-c power cord and plug, brown, for Models 514 or 542	.70				

* Used on previous receivers.

MODELS 514,
542, 543

CLOCK PARTS LIST—FOR RADIO MODELS 514, 542 AND 543

Any item bearing a Telechron catalogue number may be procured through a Telechron Service Station. Inasmuch as radio parts and clock parts procurement procedures may differ, it is suggested you contact your General Electric Radio Distributor for assistance. All or at least those items bearing General Electric catalogue numbers may also be procured directly through the General Electric Radio Distributor.

MODEL 514 CLOCK ASSEMBLY
G.E. CAT. NO. RZC-022, TELECHRON NO. C51G22

APPEARANCE ITEMS			MOVEMENT ITEMS (Cont'd)		
Description	G.E. Cat. No.	Telechron Cat. No.	Description	Symbol	Telechron Cat. No.
Alarm Disc (Black, white figures).....		55X48	*Base Plate Assembly.....	21	35X101
*Crystal-Bezel (Plastic).....	RZA-013	58X129	*Cam Shaft Assembly.....	26	17X10
Dial Face (Gold and black, gold figures).....		61X1056	*Cam Shaft Washer.....	25	40X252
*Dial and Crystal Spacer (paper).....	RZJ-002	59X772	*Field and Coil.....	23	45X209
Hands, Hour and Minute (Black).....		32X308	Field Screw (2).....	13	1X1
*Hand, Sweep Second (Red).....		31X81	Front Plate Assembly.....	16	34X287
*Knob, Alarm or Switch Set (Ivory).....	RZK-003	59X716	*Hour Hand Sleeve.....	18	13X11
*Knob, Time Set (Bronze).....		3X36	*Intermediate Gear Assembly.....	27	40X87
			*Minute Hand Sleeve.....	19	14X32
			*Rotor Unit—60 cycle.....	22	44X38
			*Spreader Post (2).....	14	40X201
			*Sweep Second Hand Shaft.....	20	16X14
			*Switch Contact Assembly.....	4	40X322
			*Switch Index Spring.....	28	40X185
			*Switch Lever Assembly.....	12	40X88
			*Switch Shaft Assembly.....	8	59X782
			*Switch Shaft Spacer.....	5	40X275
			Time Set Shaft.....	11	10X151
			*Time Set Shaft Spacer.....	9	40X276
MOVEMENT ITEMS					
Description	Symbol	Telechron Cat. No.			
*Alarm Set Sleeve.....	17	15X3			
*Alarm Set Shaft (Slotted).....	31	11X43			

MODEL 542 AND 543 CLOCK ASSEMBLY
G.E. CAT. NO. RZC-021, TELECHRON NO. C57G76

APPEARANCE ITEMS			MOVEMENT ITEMS (Con't)		
Description	G.E. Cat. No.	Telechron Cat. No.	Description	Symbol	Telechron Cat. No.
Alarm Disc (Red, white figures).....		55X48	*Base Plate Assembly.....	23	35X93
Bezel, Outer Ring (Metal, gold color finish).....		54X31	*Cam Shaft Assembly.....	28	17X10
Bezel, Numeral Ring (Metal, maroon, perforated numerals).....	RZA-011	53X163	*Cam Shaft Washer.....	27	40X252
Bezel, Numeral Color Ring (paper, ivory).....	RAZ-012	59X816	*Field and Coil (60 cycles).....	25	45X209
Crystal (glass, round).....	RZW-005	58X146	Front Plate Assembly.....	16	34X285
Dial Face (Gold color, red figures).....		61X1058	*Hour Hand Sleeve.....	18	13X11
Hands, Hour and Minute (Black, radium treated tips).....		32X306	*Intermediate Gear Assembly.....	29	40X87
Hand, Sweep Second (white).....		31X103	*Minute Hand Sleeve.....	20	14X32
*Knob; Alarm, Sleep or Switch Set (Ivory).....	RZK-003	59X716	*Rotor Unit—60 cycle.....	24	44X38
*Knob, Time Set (Bronze).....		3X36	*Sleep Switch Shaft.....	35	40X308
			*Sleep Switch Lever Assembly.....	30	40X194
			*Sleep Switch Friction Assy.....	34	40X196
			*Spreader Post (2).....	13	40X201
			*Sweep Second Hand Shaft.....	22	16X14
			*Switch Contact Assembly.....	7	40X322
			*Switch Index Spring.....	11	40X185
			*Switch Yoke Lever.....	4	40X197
			Switch Shaft Assembly.....	3	59X780
			*Switch Shaft, Spacer.....	1	40X275
			*Time Set Shaft.....	8	10X141
			*Time Set Shaft Spacer.....	9	40X276
MOVEMENT ITEMS					
Description	Symbol	Telechron Cat. No.			
*Alarm Set Sleeve.....	17	15X3			
*Alarm Set Shaft (Slotted).....	33	11X41			

*Used on previous General Electric radio clocks

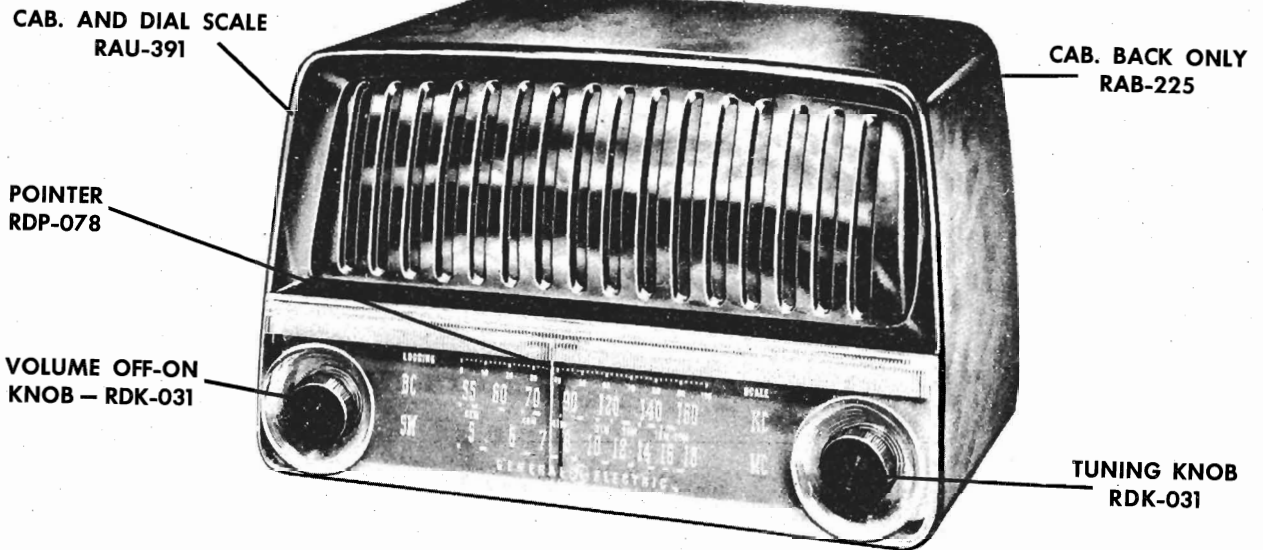

SPECIFICATIONS

CABINET	Mahogany mottle, plastic, 12¼ x 7 x 8¾ in.
INPUT	105-125 volts (using 50L6GT) or 90-110 volts (using 35L6GT) AC or DC, 50-60 cycles, 30 watts
OUTPUT	Undistorted: 1 watt; Maximum: 2 watts
LOUDSPEAKER	4-inch Alnico PM; 3.2 ohms @ 400 cps
TUBE COMPLEMENT	V1 Oscillator-Converter 12SA7 V2 I-F Amplifier 12BA6 V3 Detector-Audio Amplifier 12SQ7 V4 Audio Output For input voltages 105-125 volts. 50L6GT For input voltages 90-110 volts. 35L6GT V5 Rectifier 35Z5GT

ALIGNMENT CHART

Step	Signal Generator Output	Signal Gen. Setting	Band Switch Setting	Dial Pointer Setting	Adjust for Maximum Output
I-F ALIGNMENT					
1					Cores of 2nd i-f transformer, T3
2	Pin 8, 12SA7 grid, in series with .05 mfd	455 kc	BC	Tuning capacitor closed	Cores of 1st i-f transformer, T2
3					Recheck adjustment of T3 and T2
R-F ALIGNMENT					
4					Oscillator SW trimmer, C2C
5		18 mc	SW	18 mc	Antenna SW trimmer, C2A*
6	In series with 200 mmf to antenna input (green wire lead)				Oscillator BC trimmer, C6
7		1500 kc		1500 kc	Antenna BC trimmer, C1
8		580 kc	BC	For max.	Oscillator BC padder, C3*
9		1500 kc		1500 kc	Recheck adjustment of trimmers C6 and C1, steps 6 and 7

GENERAL INFORMATION

The normal input rating of this receiver is in the range of 105 to 125 volts. In the event of low power line voltage conditions, the receiver may be operated efficiently at 90 to 110 volts by substituting a 35L6GT audio output tube in place of the 50L6GT tube.

Note: When servicing or aligning this receiver always use an isolation transformer to protect test equipment.

ALIGNMENT

For r-f alignment, the low frequency limit of dial pointer travel should be checked with tuning gang fully closed and reset, if necessary, to a measured distance of 2 3/8 inches from center of front plate to pointer. To facilitate alignment, this reference point, as well as 4 inches (18 mc) and 3 3/4 inches (1500 kc) measured along the front plate from low frequency end of dial scale, may be marked with pencil on the back of front plate at the edge of pointer slider.

The volume control should be kept at maximum and the signal generator output attenuated so that the output meter reading does not exceed 1 1/4 volts.

After the chassis has been aligned and replaced into the cabinet, the pointer, at the low frequency end of its travel, should rest on the zero point of the logging scale. A slight inaccuracy in calibration may be corrected by moving the chassis slightly sideways.

* **ALIGNMENT NOTE:**
This adjustment is "rocked in" for maximum output.

MODEL 436

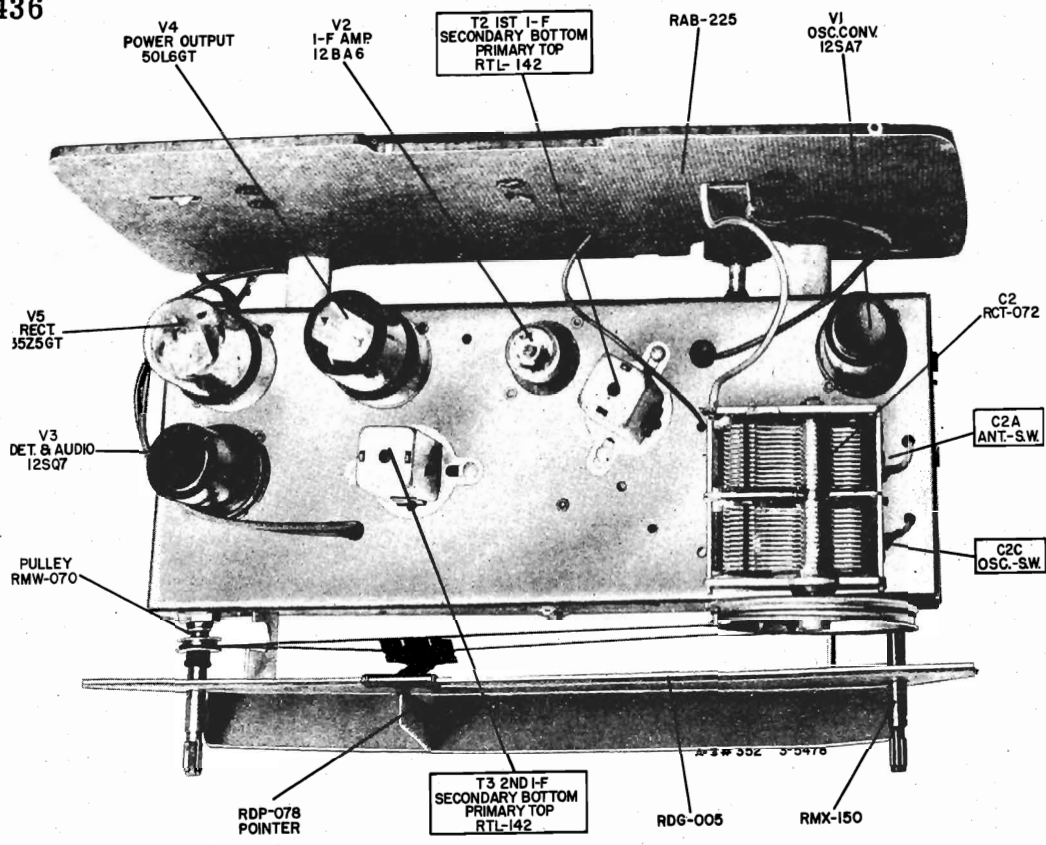

CHASSIS TOP VIEW

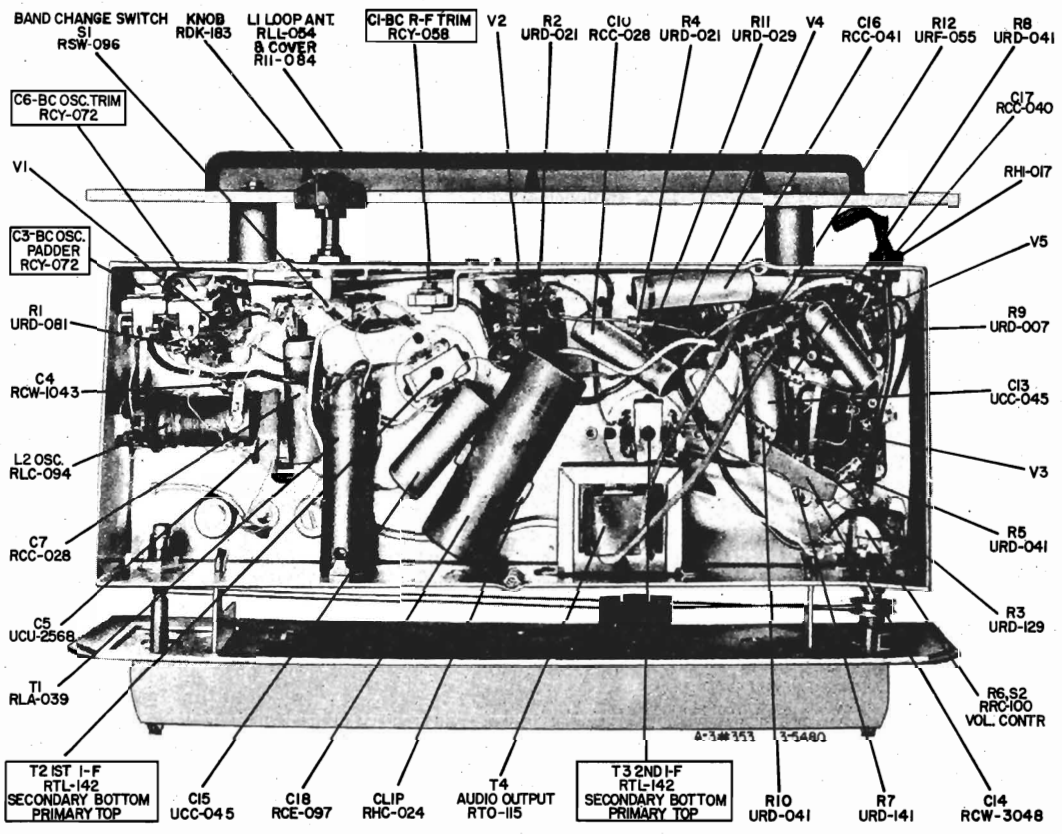

CHASSIS BOTTOM VIEW

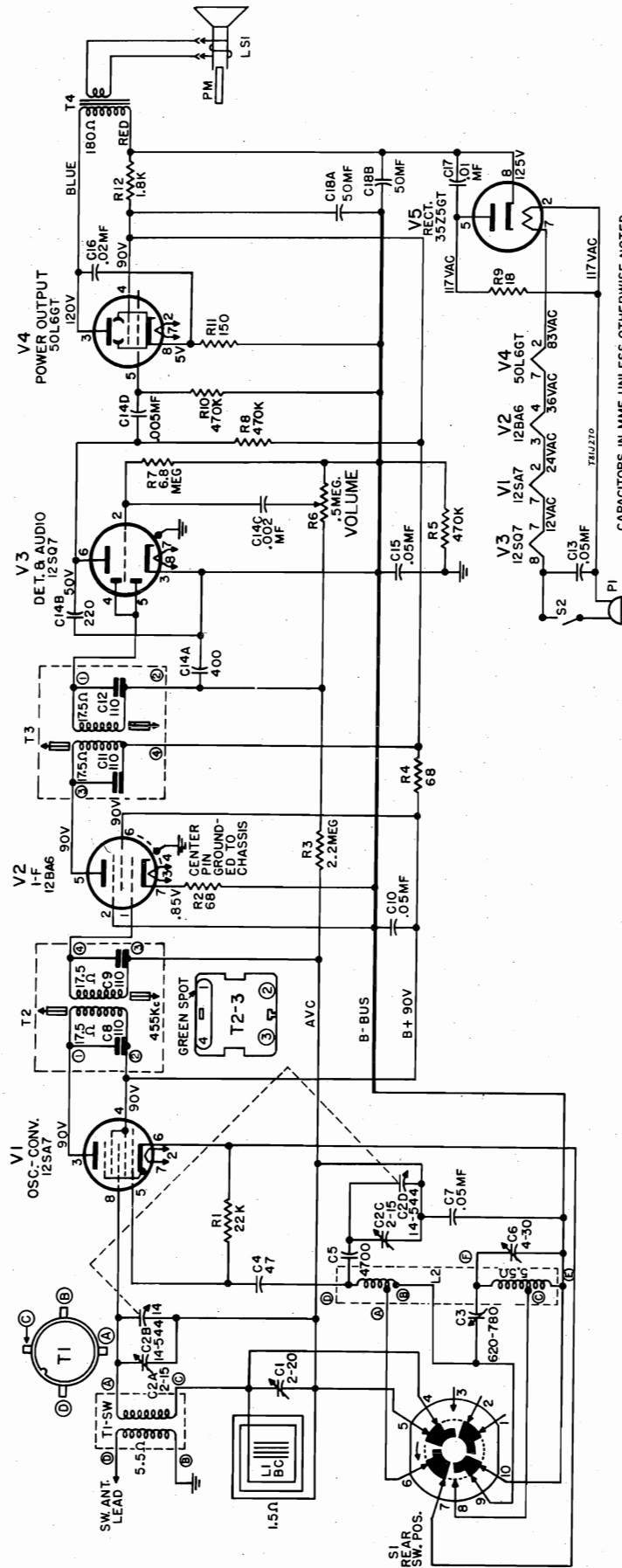

CAPACITORS IN MMF UNLESS OTHERWISE NOTED.
RESISTORS IN OHMS, K=1000 MEG.=1,000,000.
VOLTS MEASURED AT 117VAC. LINE 200000 VOLTMETER
WITH RESPECT TO B+. TUNING COND. CLOSED, VOLUME
CONTROL AT MINIMUM.

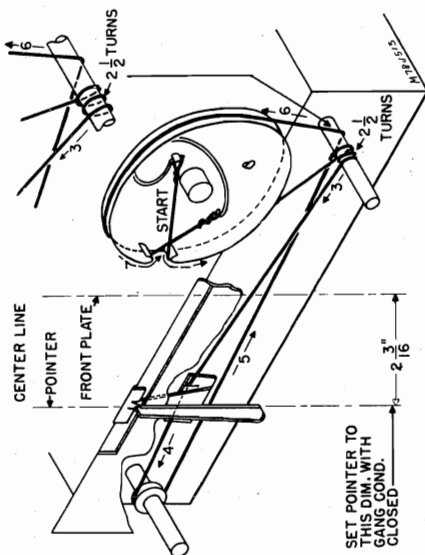

DIAL STRINGING DIAGRAM

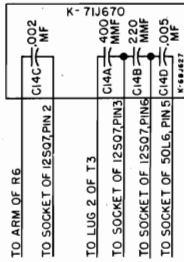
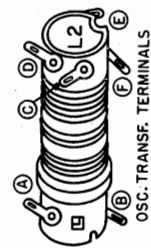

BULLPLATE

PARTS LIST

Cat. No.	Symbol	Description	Unit Price
CAPACITORS			
*RCC-028	C10	.05 mf, +40 -10%, 400 v., paper	\$0.25
*RCC-040	C17	.01 mf, +40 -10%, 600 v., paper	.30
*RCC-041	C16	.02 mf, +40 -10%, 600 v., paper	.30
*RCE-097	C18B, C	50-50 mf, 150 v., electrolytic	1.70
RCT-072	C2A, B, C, D	TUNING—Two-gang with drive drum	9.00
*RCW-1043	C4	47 mmf, ±2%, 0 temp. coeff. ceramic	.60
*RCW-3048	C14A, B, C, D	BULLPLATE—Consists of four capacitors in two sections: 1-.002 mmf, +100 -0%, 2-440 mmf, +220 -0%, +70 -30%, .005 mmf, +100 -0%	
*RCY-058	C1	TRIMMER—2-20 mf	.90
RCY-072	C3, 6	TRIMMER	1.65
*UCC-045	C7, 13, 15	.05 mf, +40 -10%, 600 v., paper	.30
*UCU-2568	C5	4700 mmf, ±5%, 500 v., mica	.85
RESISTORS			
RRC-100	R6, S2	VOLUME CONTROL & SWITCH—500,000 ohms	1.65
*URD-007	R9	18 ohms, ±10%, 1/2 w.	.13
*URD-021	R2, 4	68 ohms, ±10%, 1/2 w.	.13
*URD-029	R11	150 ohms, ±10%, 1/2 w.	.13
*URD-081	R1	22,000 ohms, ±10%, 1/2 w.	.13
*URD-113	R5, 8, 10	470K ohms, ±10%, 1/2 w.	.13
*URD-129	R3	2.2 meg., ±10%, 1/2 w.	.13
*URD-141	R7	6.8 meg., ±10%, 1/2 w.	.13
*URF-055	R12	1800 ohms, ±10%, 2 w.	.25
COILS AND TRANSFORMERS			
*RLA-039	T1	COIL—Antenna coil, short wave	1.75
*RLC-094	L2	COIL—Oscillator coil	3.50
RLI-054	L1	LOOP ANTENNA—Ferrite core	1.50
*RTL-142	T2, 3	TRANSFORMER—1st and 2nd I-F	1.85
*RTO-115	T4	TRANSFORMER—Audio output	1.90
MISCELLANEOUS ELECTRICAL			
*RJS-003		SOCKET—For tubes 50L6, 35Z5, 12507, 12SA7	\$0.20
*RJS-141	S1	SOCKET—For 12BA6	.20
*RSW-096		SWITCH—Band change switch	1.75
*RWL-009		CORD—Power cord & plug, brown, Avon plug, 12' long	.70
*S403-D7	LS1	LOUDSPEAKER—4-inch P.M.	4.30
MISCELLANEOUS MECHANICAL			
*RAP-036		PLATE—I-F adapter plate	.10
*RDC-032		CORD—Drive cord, 25 yds. bulk	2.50
RDG-005		BACKPLATE—Dial scale backplate (grey)	.30
*RHC-024		CLIP—Electrolytic mounting clip	.10
*RHC-038		CLIP—Antenna mounting	.02
*RHC-053		CLIP—I-F can mounting	.02
*RHG-006		SLEEVE—Volume control shaft, fiber	.05
*RHG-012		GROMMET—For front chassis mounting	.05
*RHG-040		GROMMET—For rear chassis mounting	.05
*RHI-017		CORD—Strain relief—Two-piece insulator for power cord	.15
*RII-084		LOOP SHIELD—Antenna cover, polystyrene	.60
*RMM-206		CORK—For front chassis mounting	.05
*RMS-118		SPRING—Dial cord tension spring	.10
*RMW-070		FULLEY—Idle pulley	.05
*RNX-150		SHAFT—Tuning control shaft mounting bushing, less nut	.50
CABINET AND APPEARANCE ITEMS			
RAB-225		BACK—Cabinet back less antenna	.40
RAU-391		CABINET AND DIAL SCALE—Plastic, mahogany	11.50
*RDK-031		KNOB—Mahogany, f. tuning and volume control	.10
*RDK-183		KNOB—Band change switch, mahogany	.15
RDP-078		POINTER—Dial pointer, red plastic flag	.45

*Parts used on previous receivers.

PRICES ARE SUGGESTED LIST PRICES AND SUBJECT TO CHANGE WITHOUT NOTICE

GENERAL INFORMATION

TYPE - AC-DC table model superheterodyne with loop antenna.

TUNING RANGE - 535 to 1620 Kc

IF FREQUENCY - 455 Kc

TUBE COMPLEMENT - 12BE6 - Converter
12BA6 - IF Amplifier
12AT6 - Detector, AVC & 1st AF Amp
50C5 - Power Amplifier
35W4 - Rectifier

POWER SUPPLY - 117V AC (50 to 60 cycles) or DC, 30 watts

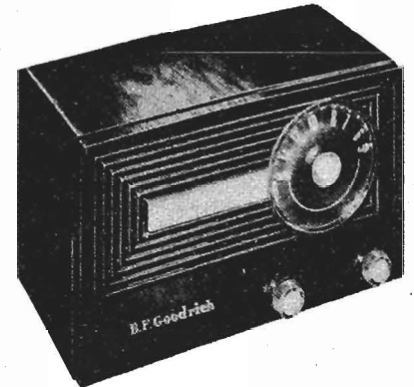

INSTALLATION & OPERATING INSTRUCTIONS

POWER SWITCH AND VOLUME CONTROL. The power switch and volume control are combined and operated with the left-hand knob. Turn radio ON by rotating volume knob to the right until a click is heard. Continued rotation of this control to the right will increase volume. Turn receiver OFF by rotating volume knob to the left until a click is heard.

NOTE: When operating from AC line, reverse power line plug for minimum hum. If the receiver does not operate from a DC power line after being turned ON for a few minutes, reverse the power line plug.

TUNING. Stations are tuned in with the right-hand knob. Tune carefully until you are exactly on the station; tuning to either side of it will result in noisy reception and poor tone quality. Do not regu-

late volume by detuning the station; always tune exactly on the station, then adjust volume control to desired loudness.

ANTENNA. A loop antenna is built into this receiver, eliminating the need for an external antenna. Reception from some stations may be improved by rotating the whole receiver; this is due to the slight directional characteristic of the loop antenna. In extremely noisy locations, rotate the entire receiver till minimum noise and maximum signal pick-up are obtained. For additional pick-up, an external antenna may be connected as shown on back of receiver.

CAUTION: Never connect antenna or chassis to water pipe, radiator or other ground.

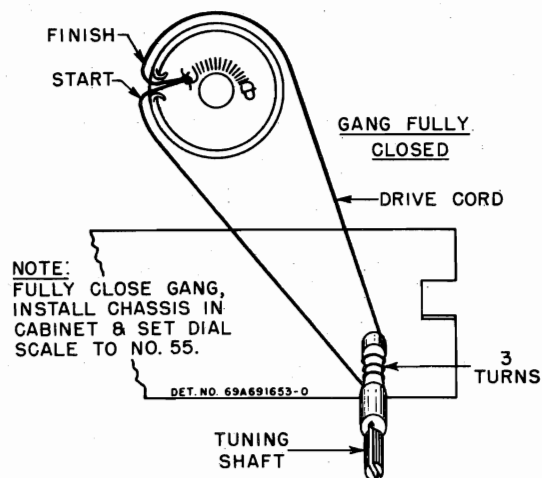

FIGURE 1. STRING DRIVE DETAIL

MODELS 92-523,
-524, -525, -526

TO REMOVE CHASSIS FROM CABINET

1. Remove dial scale; it pulls off.
2. Remove the knobs; they pull off.
3. Remove the two split plugs that hold top of loop panel to cabinet.
4. Remove the two screws that hold the chassis to the cabinet. These screws are accessible through slots in the loop panel.
5. Slide chassis out of cabinet.

ALIGNMENT

If AC power is used, use an isolation transformer between power line and receiver. If isolation transformer is not available, connect low side of signal generator to B- through .1 mf capacitor.

maximum. For greatest accuracy, keep output of receiver at approximately .05 watt (.05 watt = .40 volt on output meter) throughout alignment by reducing signal generator output as stages are brought into alignment. Use a small fibre screwdriver for aligning IF & diode transformers.

Connect a low range output meter across the speaker voice coil and set the volume control at

STEP	DUMMY ANTENNA	GENERATOR CONNECTION	GENERATOR FREQUENCY	GANG SET TO	ADJUST	REMARKS
IF ALIGNMENT						
1.	.1 mf	Rear stator of tuning cap	455 Kc	Gang opened	1, 2, 3 & 4	Adjust for maximum.
RF ALIGNMENT						
2.	.1 mf	Rear stator of tuning cap	1620 Kc	Gang opened	5	Adjust for maximum.
3.	None	Radiation loop*	1400 Kc	Tune for maximum	6	Adjust for maximum.

*Connect generator output to 5" diameter, 3 turn loop & couple to receiver loop. Keep loops at least 12" apart.

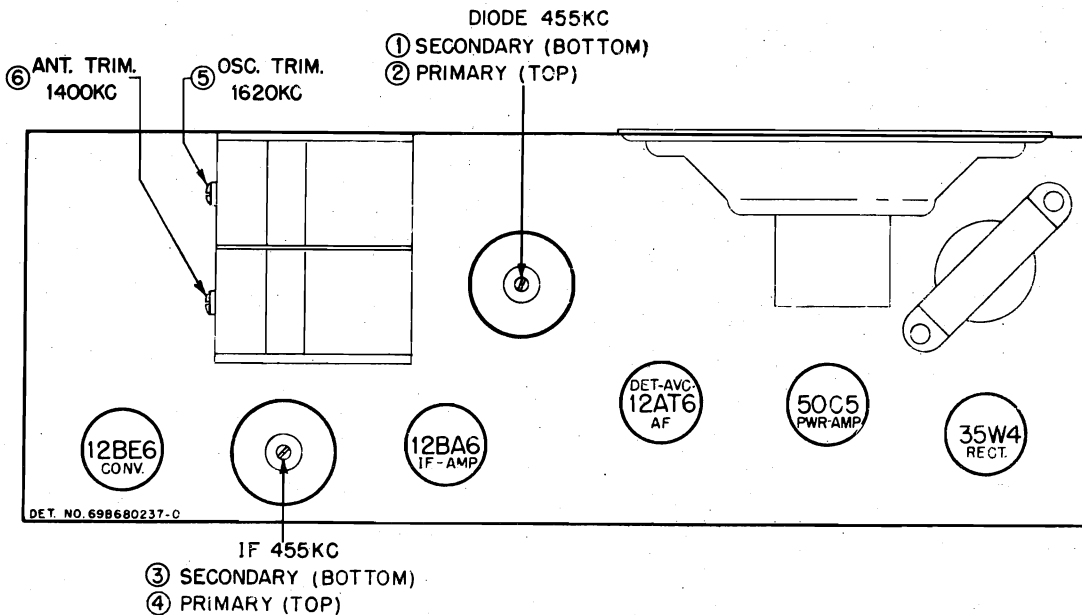

FIGURE 2. TUBE & TRIMMER LOCATION

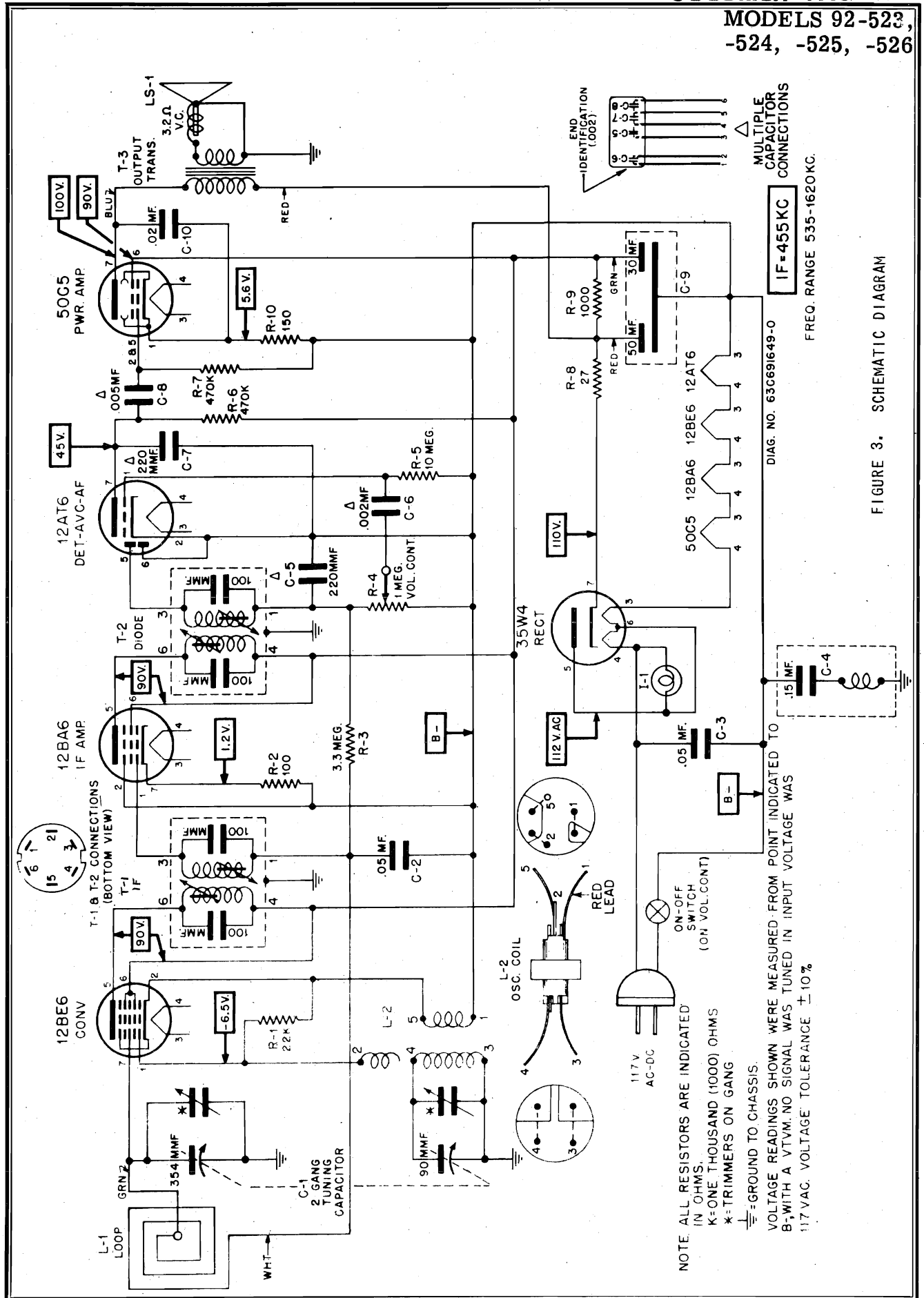

FIGURE 3. SCHEMATIC DIAGRAM

PAGE 23-4 GOODRICH

**MODELS 92-523,
-524, -525, -526**

REF. NO.	PART NO.	DESCRIPTION	LIST PRICE	PART NO.	DESCRIPTION	LIST PRICE
CHASSIS PARTS - ELECTRICAL						
CAPACITORS						
C-1	1X485960	Variable, 2-gang: includes pulley	2.65	29R3010	Lug, soldering: #6; hot tinned (gang)doz	.30
C-2	8K691444	Paper: .05 mf 200V20	2S7051	Palnut, hex: 3/8-32 x 9/16; cad pl (volume control mtg)doz	.15
C-3	8K691443	Paper: .05 mf 400V20	5S7771	Rivet: .088 x 3/16; stl; pol nkl (tube socket mtg)per/c	.50
C-4	8A691842	Paper: .15 mf (resonant at 455 Kc)60	5S7707	Rivet: .122 x 5/32 stl; nkl pl (spring tube shield mtg & output transformer mtg)...per/c	.50
C-5,6,7,8	21B482847	Ceramic, multiple: 220 mmf; .002 mf; 220 mmf; .005 mf (all 400 wv)65	5S7701	Rivet: .122 x 3/16; stl; nkl pl (tuning shaft bracket mtg)per/c	.50
C-9	23A691441	Electrolytic: 50 mf-30 mf/150V	1.10	3S2294	Screw, machine: 6-32 x 1/2 plain hex head; locking type; cad pl (gang mtg)doz	.15
C-10	8A691442	Paper: .02 mf 400V20	3S7205	Screw, machine: 8-32 x 1/4 slotted hex head; locking type; cad pl (pilot light brkt mtg)doz	.15
DIAL LIGHT						
I-1	65X11854	Bulb: 6.3V-.15A; tubular; clear; #4715	3S3398	Screw, sheet metal: #6 x 3/8 PKZ plain hex head; cad pl (bracket, loop mtg)per/c	.50
COILS						
L-1	24K691446	Loop Antenna: includes back panel	1.05	3S7454	Screw, sheet metal: #8 x 1/4 PKZ plain hex head; cad pl (speaker mtg)per/c	.50
L-2	24K690762	BC Oscillator Coil65	3S7455	Screw, sheet metal: #8 x 3/8 PKA slotted acorn head; antique copper finish (loop mtg)doz	.15
SPEAKER						
LS-1	50K691765 or 50C478138	Speaker, PM: 4"; 3.2 ohm VC	2.60	47A482845	Shaft, tuning15
		exch	1.95	26K485936	Shield, coil (T-1 & T-2)20
RESISTORS						
Note: All resistors are insulated carbon type unless otherwise specified.						
R-1	6R6028	22,000 20% 1/2Wdoz	1.00	26A481521	Shield, spring (tube shield).doz	.50
R-2	6R6018	100 20% 1/2Wdoz	1.00	9A485979	Socket, pilot light & bracket...	.30
R-3	6R2118	3.3 meg 20% 1/2Wdoz	1.00	9A472534	Socket, tube: miniature15
R-4	18A691440	Volume control: 1 meg; includes ON-OFF switch	1.00	41A691088	Spring, tension coil (elect. cap retaining)10
R-5	6R2109	10 meg 20% 1/2Wdoz	1.00	41A14111	Spring, tension coil (dial cord)40
R-6	6R6032	470,000 20% 1/2Wdoz	1.00	4A70015	Washer, 'C' (tuning shaft re-tainer)per/c	.50
R-7	6R6032	470,000 20% 1/2Wdoz	1.00	4S7633	Washer, flat: 9/16 x 11/64 x .033 stl; cad pl (loop mtg).doz	.15
R-8	6R5683	27 10% 1/2Wdoz	1.00	4K482859	Washer, insulated shoulder (loop mtg brkt)doz	.15
R-9	6R3953	1000 20% 1Weach	.15	CABINET PARTS		
		doz	1.45	16E690434	Cabinet, table model: plastic; walnut	3.95
R-10	6R3992	150 20% 1/2Wdoz	1.00	16K690438	Cabinet, table model: plastic; ivory	5.40
SWITCH						
S-1	-	SPST Switch; part of volume control R-4	-	16K690436	Cabinet, table model: plastic; green	5.40
TRANSFORMERS						
T-1	24B482863	IF, 455 Kc: complete	1.70	16K691447	Cabinet, table model: plastic; maroon	5.40
T-2	24B482865	Diode, 455 Kc: complete ...	1.70	42A485984	Clip, dial scale retainer ...doz	.20
T-3	25K485973	Output Transformer65	36B690442	Knob, control: plastic; walnut25
CHASSIS PARTS - MECHANICAL						
				36K690444	Knob, control: plastic; ivory25
	7K690449	Bracket, loop mtg10	36K691460	Knob, control: plastic; green25
	7A690445	Bracket, pilot light mtg.....	.10			
	7A77337	Bracket, tuning shaft mtg.....	.05	36K691459	Knob, control: plastic; maroon25
	11M8944	Cord, dial: 18 lb; blk.....yd	.10			
	30A470651	Cord, line & plug: 6 ft long75	38A25507	Plug, split (loop & back to cabinet mtg)doz	.15
	46K680318	Core, iron: threaded (for T-1 & T-2)10	34C690441	Scale, dial55
	5A19658	Eyelet, spacer (gang mtg) ...doz	.20	3S7374	Screw, machine: 8-32 x 5/16 plain hex head; cad pl (chassis mtg)per/c	.50
	5A70404	Grommet, rubber (gang mtg) ..doz	.60			
	14A482844	Insulator, cord outletdoz	.25			

PRICES SUBJECT TO CHANGE WITHOUT NOTICE

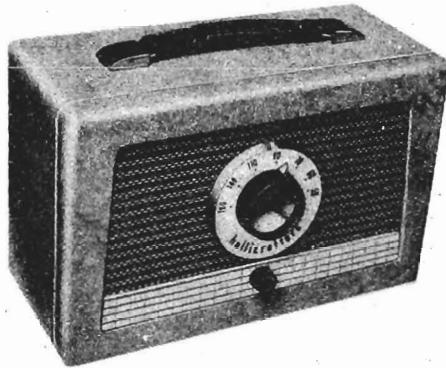

Fig. 1. Radio Receiver Model 5R24

92X1525

SPECIFICATIONS

Tubes and Rectifiers 4 tubes and 1 selenium rectifier
 Power Supply 105-125 volts DC/50-60 cycle AC or 90 and 7½ volt batteries
 Frequency Coverage 540 KC to 1650 KC
 Intermediate Frequency 455 KC
 Speaker 4 inch PM
 Voice Coil Impedance. 3.2 ohms
 Antenna Built-in loop

REPLACEMENT BATTERIES

7½V "A" - Eveready 717, Burgess C5, RCA VS 065
 90V "B" - Eveready 490, Burgess N60, RCA VS 090

ALIGNMENT PROCEDURE

- Connect output meter across voice coil.
- Turn volume control at maximum.
- Use a non-metallic alignment tool.
- Loop antenna must be connected.
- Refer to Fig. 2 for location of alignment adjustments.
- Generator must have a modulated output.
- Align for maximum output. To prevent AVC action from interfering with alignment, use lowest output setting of generator that gives satisfactory reading on output meter (approximately 50 milliwatts).

STEP	SIGNAL GENERATOR CONNECTION	SIGNAL GENERATOR FREQUENCY	RECEIVER DIAL SETTING	ADJUST FOR MAXIMUM OUTPUT
1	High side to pin 6 of the 1R5 through a .1 mfd. capacitor. Ground side to B-.	455 KC	Tuning gang fully open.	A,B,C,D
2	Same as STEP 1.	1650 KC	Tuning gang fully open.	E
3	Place generator lead close to loop antenna. No actual connection.	1500 KC	1500 KC	F

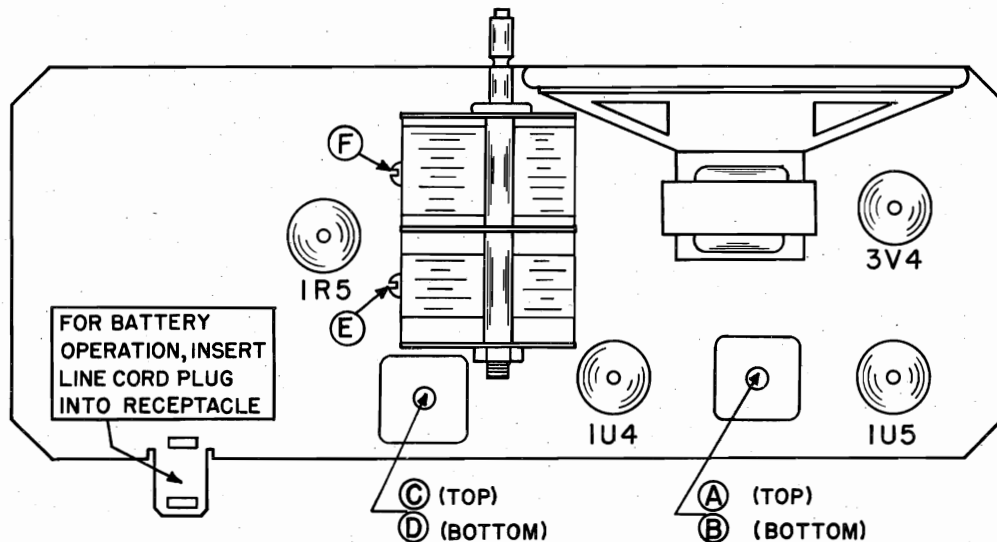

92B1515

94X807

Fig. 2. Top View of Chassis Showing Location of Alignment Adjustments and Tubes

MODEL 5R24

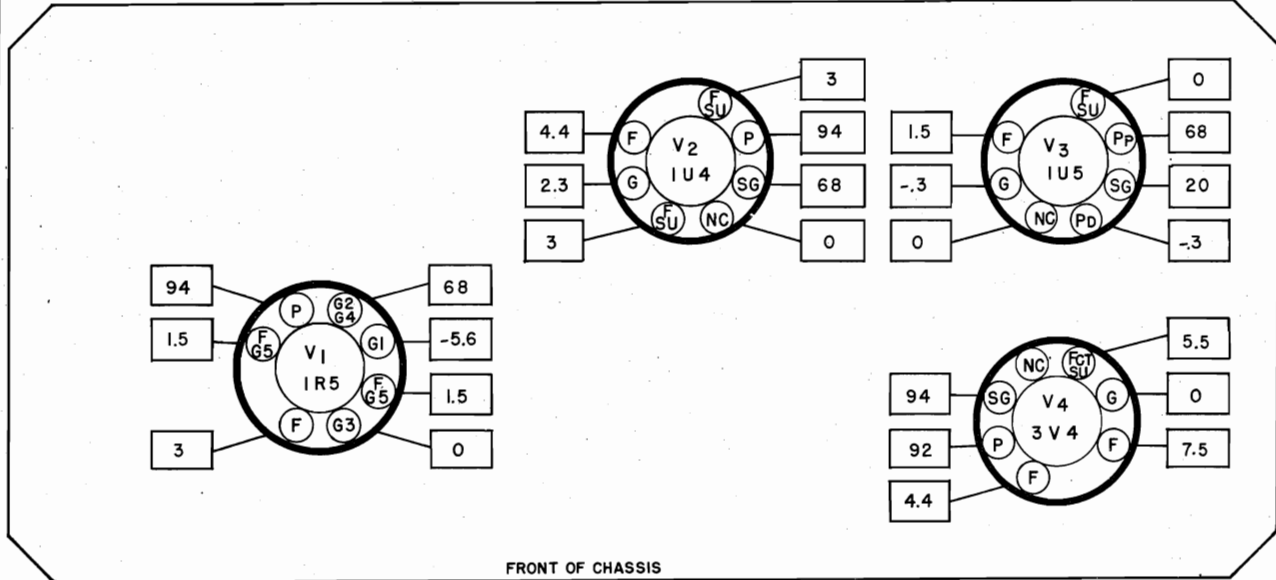

FRONT OF CHASSIS

NOTES

1. SOCKET VIEWS ARE BOTTOM VIEWS.
2. ALL VOLTAGES MEASURED BETWEEN TUBE SOCKET TERMINALS AND B- (NOT CHASSIS) WITH ZERO SIGNAL INPUT.
3. LINE VOLTAGE - 117 VOLTS AC.
4. LOOP ANTENNA CONNECTED AND TUNING GANG FULLY MESHD.
5. ALL VOLTAGES ARE DC AND POSITIVE UNLESS OTHERWISE SPECIFIED.
6. ALL VOLTAGES MEASURED WITH A VACUUM TUBE VOLTMETER.
7. NC-NO CONNECTION. VOLTAGE SHOWN FOR THIS TERMINAL ONLY WHEN USED AS A TIE LUG.

Fig. 3. Tube Socket Voltage Chart

92C1524

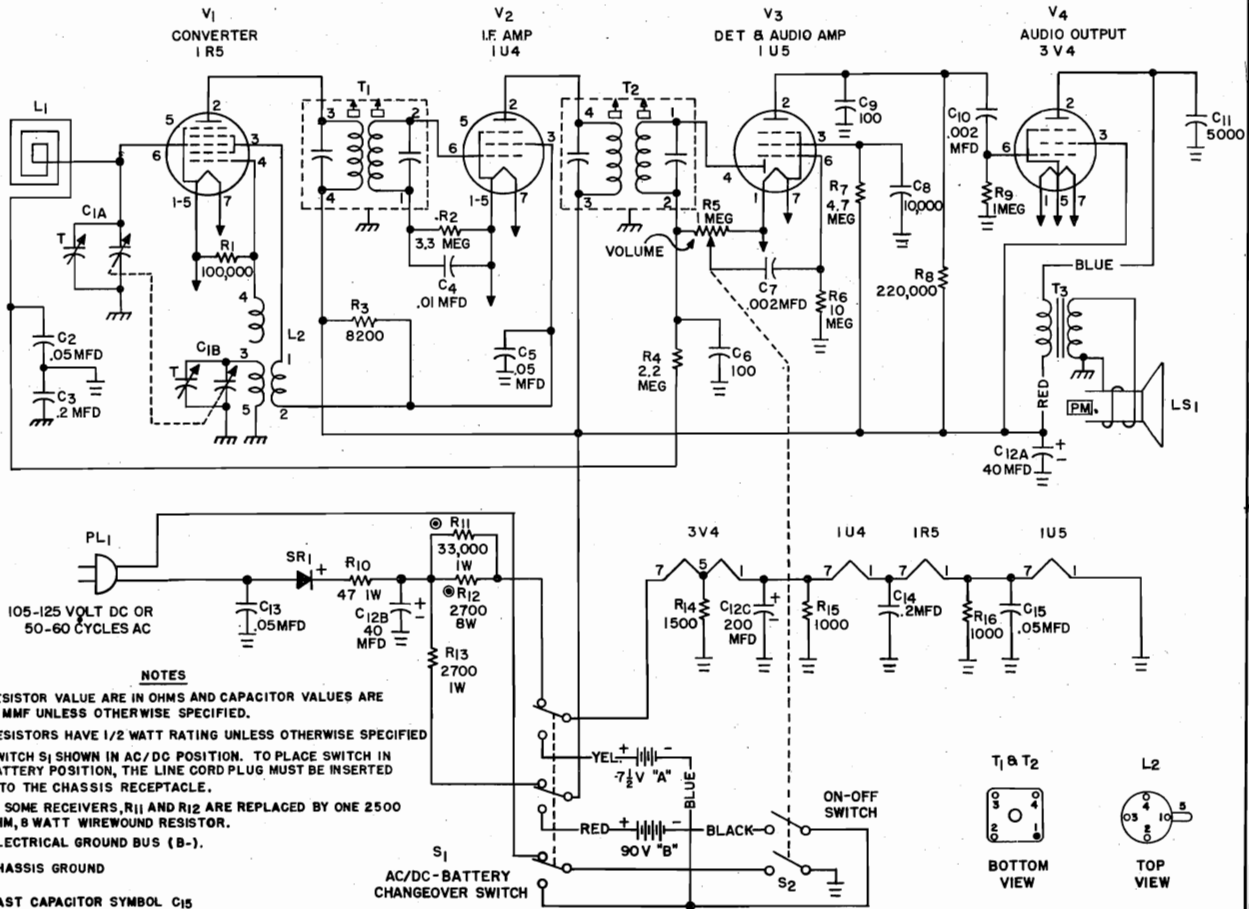

NOTES

1. RESISTOR VALUE ARE IN OHMS AND CAPACITOR VALUES ARE IN MMF UNLESS OTHERWISE SPECIFIED.
 2. RESISTORS HAVE 1/2 WATT RATING UNLESS OTHERWISE SPECIFIED
 3. SWITCH S₁ SHOWN IN AC/DC POSITION. TO PLACE SWITCH IN BATTERY POSITION, THE LINE CORD PLUG MUST BE INSERTED INTO THE CHASSIS RECEPTACLE.
 - ⊙ IN SOME RECEIVERS, R₁₁ AND R₁₂ ARE REPLACED BY ONE 2500 OHM, 8 WATT WIREWOUND RESISTOR.
 - ⊕ ELECTRICAL GROUND BUS (B-).
 - ⏏ CHASSIS GROUND
- LAST CAPACITOR SYMBOL C₁₅
LAST RESISTOR SYMBOL R₁₆

Fig. 4. Schematic Diagram

89C397

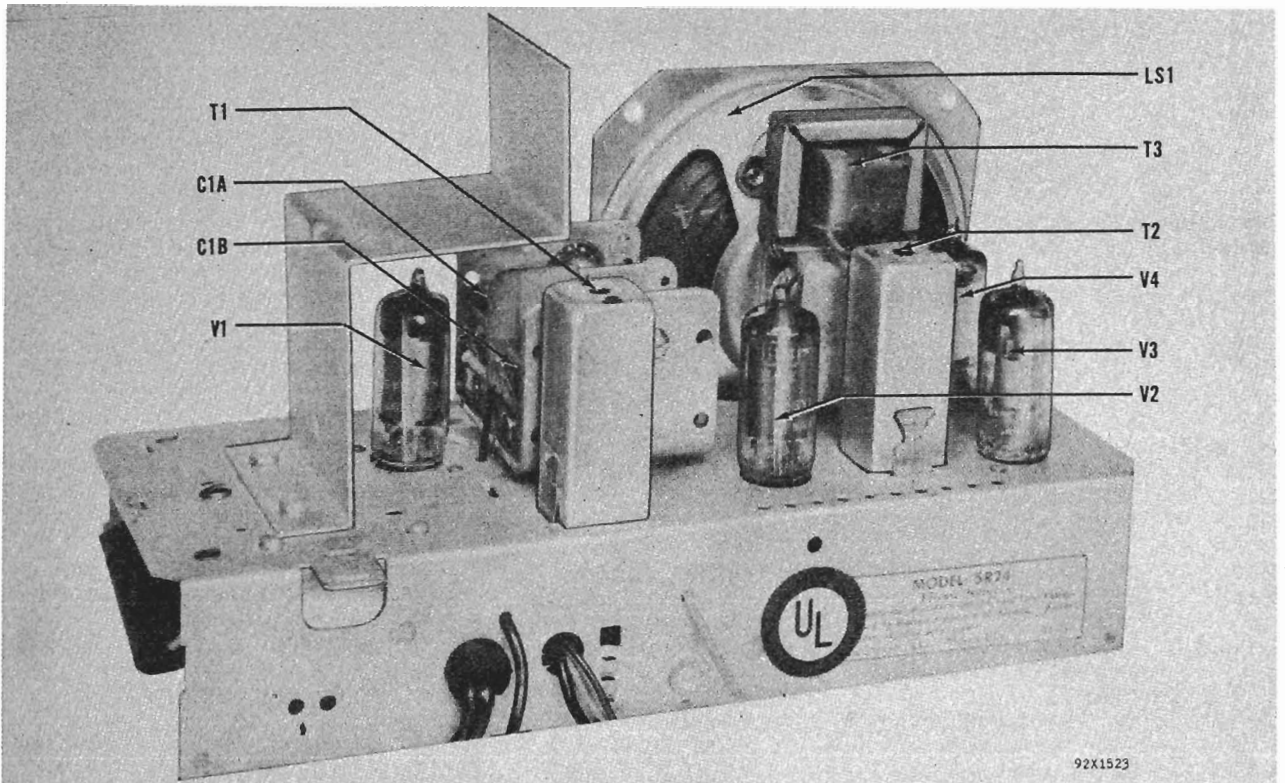

Fig. 5. Top View of Chassis Showing Component Location

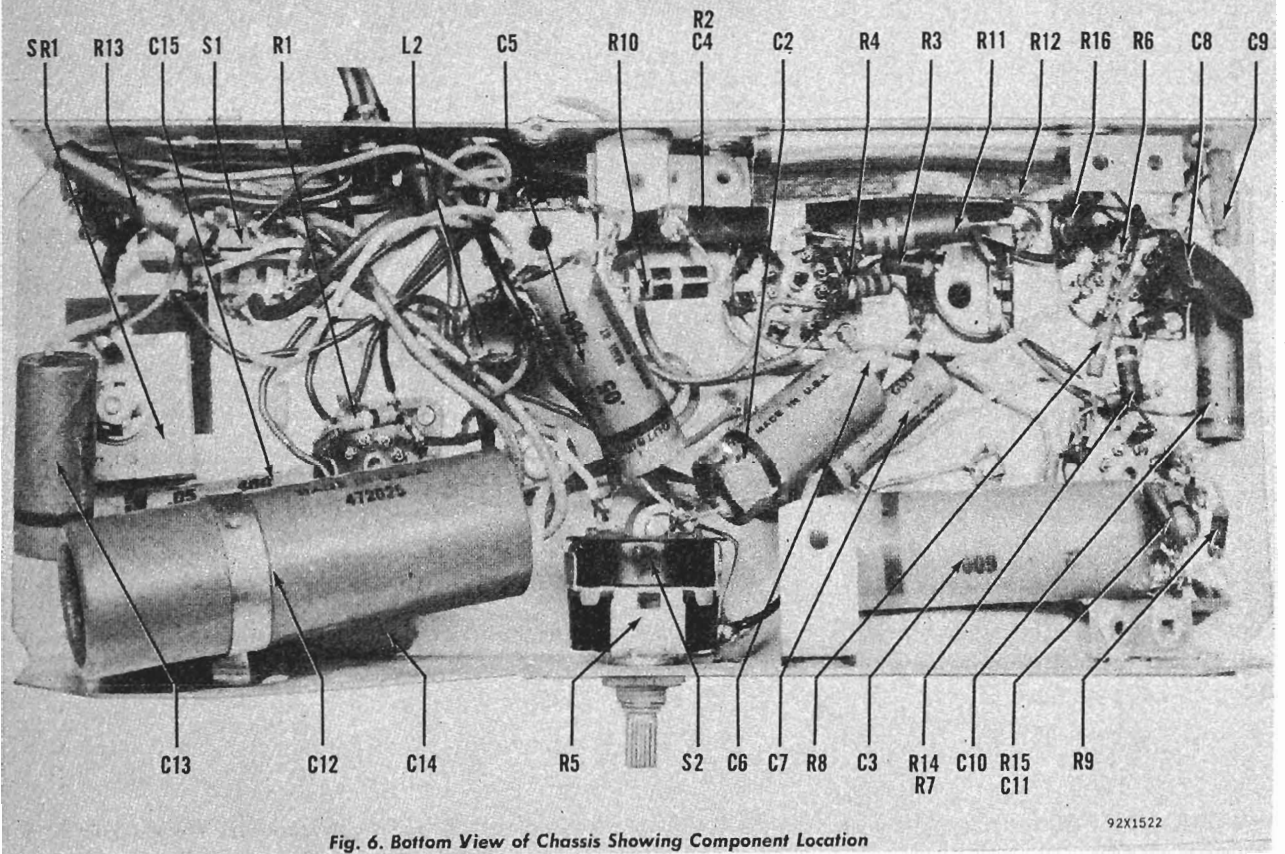

Fig. 6. Bottom View of Chassis Showing Component Location

MODEL 5R24

SERVICE PARTS LIST

Schematic Symbol	Description	Hallicrafters Part Number	Schematic Symbol	Description	Hallicrafters Part Number
CAPACITORS			PLUGS AND SOCKETS		
C-1A,B	Tuning capacitor, 2 section	48-280		Plug assembly, "B" battery; male (includes lead)	87-1972
C-2	.05 mfd. 200V., tubular	46AU503J		Plug assembly, "B" battery; female (includes lead)	87-3508
C-3,14	.2 mfd. 400V., tubular	46AW204J		Plug assembly, "A" battery; includes leads	87-1971
C-4	.01 mfd. 200V., tubular	46AU103J		Plug, line cord (part of line cord 87-1973)	-----
C-5,13,15	.05 mfd. 400V., tubular	46AW503J		Socket, tube; 7 pin miniature (for tubes V-1, V-3 and V-4)	6-404
C-6,9	100 mmf. 500V., mica	47X20B101M	PL-1	Socket, tube; 7 pin miniature (for tube V-2)	6-403
C-7	.002 mfd. 200V., tubular	46AU202J			
C-8	10,000 mmf. 450 V., ceramic disc	47A224			
C-10	.002 mfd. 400V., tubular	46AW202J			
C-11	5000 mmf. 450V., ceramic disc	47A168			
C-12A,B,C	Dual 40 mfd. 150V., 200 mfd. 15V., electrolytic	45-193			
RESISTORS			TUBES AND RECTIFIERS		
R-1	100,000 ohms 1/2 watt, carbon	23X20X104M	V-1	1R5: converter	90X1R5
R-2	3.3 megohms 1/2 watt, carbon	23X20X335M	V-2	1U4: IF amplifier	90X1U4
R-3	8200 ohms 1/2 watt, carbon	23X20X822M	V-3	1U5: detector, AVC and audio amplifier	90X1U5
R-4	2.2 megohms 1/2 watt, carbon	23X20X225M	V-4	3V4: audio output	90X3V4
R-5	Volume control, 1 megohm; includes ON-OFF switch S-2	25-963	SR-1	Selenium rectifier, 65 ma	27-162
R-6	10 megohms 1/2 watt, carbon	23X20X106M			
R-7	4.7 megohms 1/2 watt, carbon	23X20X475M			
R-8	220,000 ohms 1/2 watt, carbon	23X20X224M			
R-9	1 megohm 1/2 watt, carbon	23X20X105M			
R-10	47 ohms 1 watt, carbon	23X30X470K			
R-11*	33,000 ohms 1 watt, carbon	23X30X333M			
R-12*	2700 ohms 8 watts, wire-wound	24-937			
R-13	2700 ohms 1 watt, carbon	23X30X272K			
R-14	1500 ohms 1/2 watt, carbon	23X20X152K			
R-15,16	1000 ohms 1/2 watt, carbon	23X20X102K			
TRANSFORMERS AND COILS			MISCELLANEOUS PARTS		
T-1	Transformer, IF; input	50-521		Cabinet; includes carrying strap and back cover, does not include loop antenna or front panel	78F684
T-2	Transformer, IF; output	50-521		Clip, mtg. (for T-1 and T-2)	76A385
T-3	Transformer, audio output (part of speaker LS-1)	-----		Dial scale	83D398
L-1	Loop antenna	57-154		Front panel, cardboard; includes grille cloth	32C502
L-2	Coil, oscillator	51-1483		Grommet, rubber; for mounting tuning capacitor	16A015
				Knob, station selector	15C414
				Knob, volume control	15B413
				Line cord and plug PL-1	87-1973
				Line cord lock	76-857
			LS-1	Speaker, 4" PM; 3.2 ohm voice coil (includes output transformer T-3)	85-121
				Strip, front panel decorative	7C302
			S-1	Switch, spring slide; 3pdt (AC/DC-Battery)	60-466
			S-2	Switch, ON-OFF; part of volume control R-5	-----

* In some receivers, R-11 and R-12 are replaced by one 2500 ohm 8 watt, wirewound resistor (part #24-938).

DESCRIPTION

Your Hallicrafters Model S-80, the "Defender", is a super-sensitive, four tube battery operated radio specially designed for use in rural and remote areas where commercial power is not available. It covers both the standard broadcast band and the 6 to 18 megacycle shortwave range thus assuring 24 hour reception even in weak signal areas where the broadcast band "blacks-out" in daytime.

The receiver is designed to operate from any standard $1\frac{1}{2}$ volt "A" - 90 volt "B" heavy duty battery pack such as listed below under BATTERY INSTALLATION. These batteries will provide over 1,000 hours or approximately one year of service and will fit inside the rear of the cabinet. A special feature is the battery saver switch, a slide switch located on the chassis which will provide approximately 50 hours of additional battery operation at the normal end life of the battery.

Operation of the receiver in metropolitan areas from commercial power is easily possible by the use of a moderate cost power converter such as Perma Power Model A or Sears "Power Shifter". Such a unit equips the receiver for 110-120 volt, 50 or 60 cycle AC operation.



92X1542

Model S-80 Defender

The tuning dial is of the slide rule type with separate dial scales for both the standard broadcast and shortwave bands. Major foreign cities are clearly indicated on the shortwave portion of the dial to facilitate tuning. Shortwave services covered by this receiver include the following international shortwave bands: 5.9 to 6.2 MC, 9.5 to 9.7 MC, 11.7 to 11.9 MC, 15.1 to 15.45 MC and 17.7 to 17.9 MC.

To get the utmost enjoyment from your Hallicrafters receiver, carefully follow the instructions contained in this book.

OPERATING INSTRUCTIONS

BATTERY INSTALLATION

1. The receiver is designed to operate from any one of the following combination 90 and $1\frac{1}{2}$ volt farm battery packs: Sears 06308, Wards 51, Burgess 17GD60, RCA VSO 99, General 60DL-11L, Eveready 748, Ray-O-Vac AB-82, Bond 0528 or Ensign AB48.
2. Place the battery pack into the compartment provided in the rear of the cabinet and insert the BATTERY CABLE PLUG (see Fig. 3) into the receptacle located on the battery.
3. Set the BATTERY SAVER SWITCH on the top right of the chassis to the NEW POSITION. (See Fig. 3.) This switch should be set at NEW whenever a new battery pack is installed.

NOTE: Maximum battery life will be obtained if the receiver is operated intermittently, i.e., for short periods of time, instead of continuously for prolonged periods.

4. When the volume of stations decreases noticeably due to the battery approaching the end of its normal operating life, set the BATTERY SAVER SWITCH at USED.
5. When reception becomes weak even with the BATTERY SAVER SWITCH at USED, replace the battery pack.

**MODEL S-80,
Defender**

ANTENNA INSTALLATION

Two leads have been provided at the top left of the chassis for antenna and ground connections. A satisfactory antenna in most cases is 30 to 60 feet of wire connected to the green lead and run about the room in any convenient manner. A good ground connection is required when this type of antenna is employed. For best results, an outside antenna should be used.

SINGLE WIRE ANTENNA

1. Construct the antenna as shown in Fig. 1 and connect it to the green lead located on the top left of the chassis. (See Fig. 3.)
2. Erect the antenna as high as possible and free from surrounding objects.
3. Use an Underwriters approved lightning arrester designed for single lead-in at the point where the lead-in enters the house.
4. Connect the black lead located at the top left of the chassis to a cold water pipe or other good ground such as a six foot ground rod driven into moist soil.

For shortwave reception, a doublet antenna with a 300 ohm ribbon type transmission line is recommended. The doublet antenna, when properly constructed and installed, will provide excellent world-wide shortwave reception as well as standard broadcast reception.

DOUBLET ANTENNA

1. Construct the antenna as shown in Fig. 2. Note that the antenna is $19\frac{1}{2}$ feet long each side of center, the two sections being insulated from one another.
2. Use a length of 300 ohm ribbon type transmission line, commonly called twin-lead, as the lead-in from the antenna to the receiver. Connect one end of the transmission line to the two $19\frac{1}{2}$ foot antenna sections and the other end to the black and green leads located at the top left of the chassis.
3. Use an Underwriters approved lightning arrester designed for twin-lead at the point where the lead-in enters the house.
4. No ground connection is required with the doublet antenna.

TUNING DIAL

1. The standard broadcast band is calibrated in kilocycles with a zero deleted for convenience. To convert the dial reading to the station frequency in kilocycles, add one zero.
2. The shortwave band is calibrated directly in megacycles.

STANDARD BROADCAST AND SHORT WAVE RECEPTION

1. Set the SHORTWAVE-BROADCAST control knob to BROADCAST for standard broadcast reception or to SHORTWAVE for shortwave reception.
2. Turn the receiver ON by rotating the VOLUME control knob clockwise. Turn this control to a well advanced position and reset it for the desired volume after a station has been tuned in.
3. Tune in the desired station by turning the TUNING CONTROL knob slowly until the dial pointer indicates the station frequency.
4. Readjust the VOLUME control for the desired volume.
5. To turn the receiver OFF, turn the VOLUME control knob counterclockwise until a click is heard.

BEST SHORTWAVE RECEPTION TABLE

BAND	MOST FAVORABLE TIME	MOST FAVORABLE DISTANCE	
6-7 MC	Night - Winter	Day - 400 Miles	Night - Over 1500 Miles
9-10 MC	Day - Late Afternoon and Night - Winter	Over 500 Miles	
11-12 MC	Evenings or Late Summer Afternoons	Day - Under 1500 Miles	Night - Over 1500 Miles
15-18 MC	Early Mornings and Summer Evenings	Over 1500 Miles	

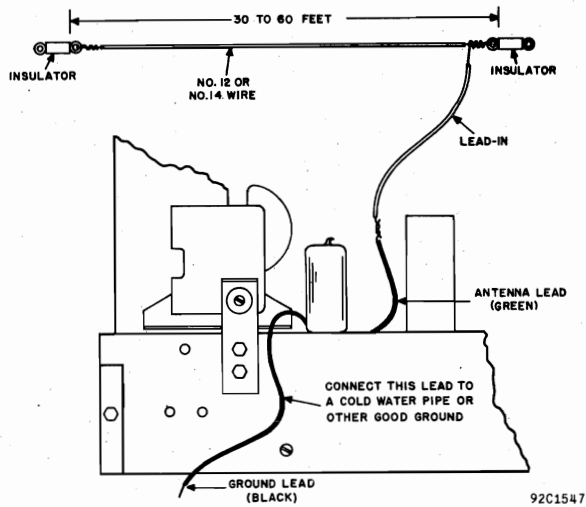

Fig. 1. Single Wire Antenna Installation

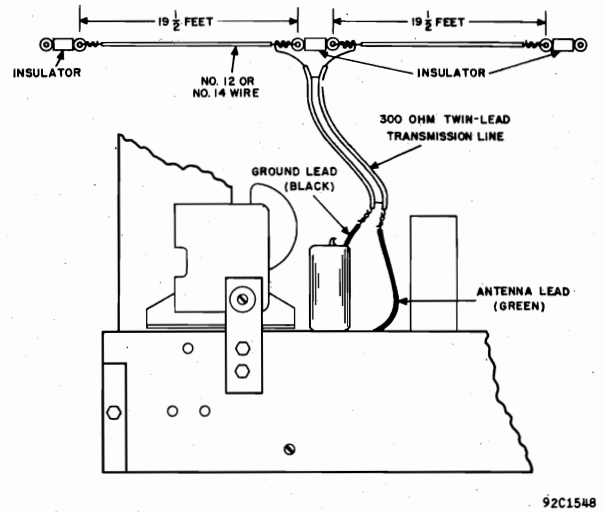

Fig. 2. Doublet Antenna Installation

SERVICE INSTRUCTIONS

SPECIFICATIONS

Tubes Four
 Speaker 5 inch PM
 Speaker Voice Coil Impedance 3.2 ohms
 Intermediate Frequency 455-KC
 Antenna Provision for external single wire
 or doublet antenna.
 Power Supply. . . . 90 volt "B" - 1 1/2 volt "A" battery pack
 Frequency Coverage. . . . 540 - 1620 KC and 6 - 18 MC

TUBE REPLACEMENT - The tube types and their relative location in the receiver are shown in Fig. 3. To gain access to all tubes, slide the battery pack out of the cabinet. When installing a replacement tube, line up the seven pins on the tube with the socket holes and push down on the tube until the base of the tube rests firmly on the socket. Handle all tubes with care as they are fragile and will not withstand mechanical abuse.

REPLACEMENT BATTERY PACKS - Sears 06308, Wards 51, Burgess 17GD60, RCA VSO 99, General 60DL-11L, Eveready 748, Ray-O-Vac AB-82, Bond 0528 and Ensign AB48.

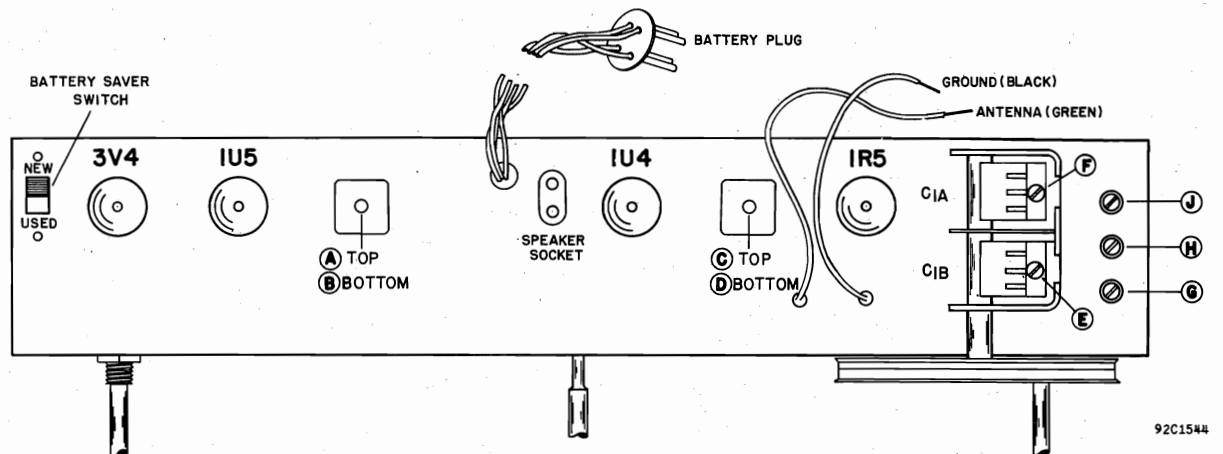
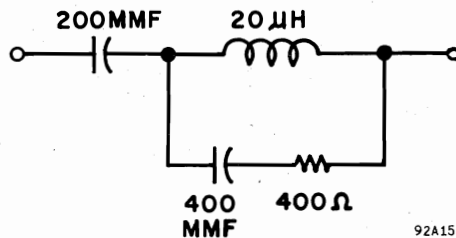

Fig. 3. Top View of Chassis Showing Location of Alignment Adjustments and Tubes

MODEL S-80,
Defender

ALIGNMENT PROCEDURE

- Connect output meter across speaker voice coil.
- Set volume control at maximum.
- Use a non-metallic alignment tool.
- Signal generator must have a modulated output and cover 455 KC, 600 KC, 1300 KC and 14 MC.
- Keep the generator output as low as possible to avoid AVC action.
- Refer to Fig. 3 for location of alignment adjustments.



92A1549

Fig. 4. RTMA Dummy Antenna

STEP	SIGNAL GENERATOR CONNECTIONS	SIGNAL GENERATOR FREQUENCY	BAND SWITCH SETTING	RECEIVER DIAL SETTING	ADJUST FOR MAXIMUM OUTPUT
1	High side to stator plates of rear section of tuning capacitor through a .01 mfd. capacitor. Low side to chassis.	455 KC	BROADCAST	1000 KC	A, B, C, D
2	High side to green antenna lead (Fig. 3) through a standard RTMA dummy antenna (Fig. 4). Low side to chassis.	14 MC	SHORTWAVE	14 MC	E, F
3	Same as STEP 2.	1300 KC	BROADCAST	1300 KC	G, H.
4	Same as STEP 2.	600 KC	BROADCAST	600 KC	J

DIAL CORD RESTRINGING

1. Set the tuning capacitor in a fully meshed position.
2. Tie one end of a 60 inch length of 30 lb. test dial cord to the tension spring at position 1. See Fig. 5.
3. Follow the stringing procedure 1 through 10. At position 10, stretch the spring and tie the cord securely to the spring.
4. With the tuning capacitor fully meshed, attach the dial pointer to the cord and align it with the left hand index marks on the dial. Cement the pointer to the cord with a drop of quick drying cement.

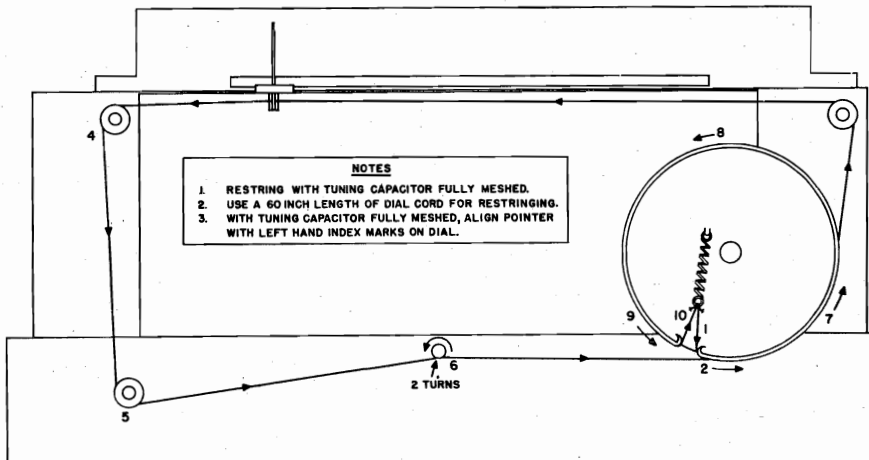

92C1543

Fig. 5. Dial Cord Stringing Procedure

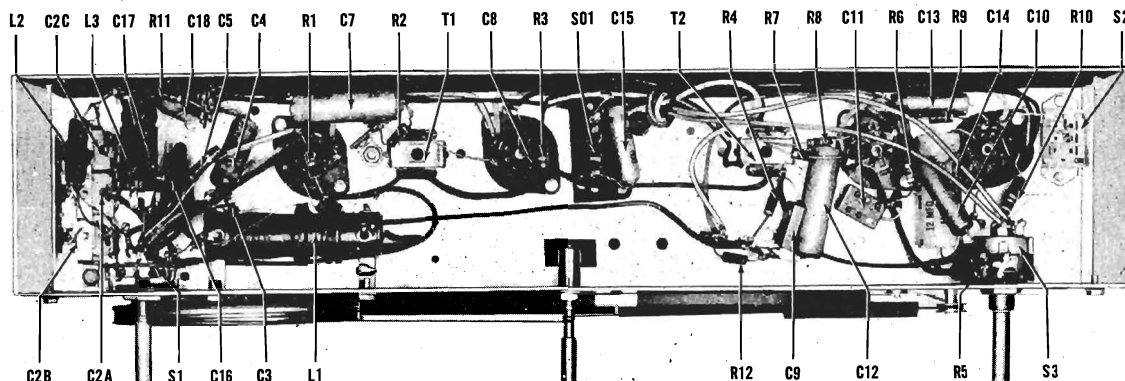

Fig. 6. Bottom View of Chassis Showing Component Location

92X1541

SERVICE PARTS LIST

Schematic Symbol	Description	Hallicrafters Part Number	Schematic Symbol	Description	Hallicrafters Part Number
CAPACITORS					
C-1A,B	Tuning capacitor, 2 section	48C274	T-2	Transformer, IF; output	50C516
C-2A,B,C	Trimmer assembly; includes mtg. bracket and 3 trimmers	44C406	T-3	Transformer, audio output; part of speaker LS-1	-----
C-3	10 mmf. 500 V., ceramic	47B20A100K5	PLUGS AND SOCKETS		
C-4	.05 mfd. 200 V., tubular	46A091	PL-1	Plug, speaker; part of speaker LS-1	-----
C-5,17	100 mmf. 500 V., ceramic	47B20A101K5	PL-2	Plug, battery cable; includes leads	87B1555-1
C-6	2.2 mmf. 500 V., ceramic	47A160-4	SO-1	Socket, speaker	6A275
C-7,12	.02 mfd. 600 V., tubular	46AY203J		Socket, tube; miniature 7 pin	6A314
C-8	1000 mmf. 500 V., ceramic	47B20A102K5	SWITCHES		
C-9,11	220 mmf. 500 V., mica	47X20B221M	S-1A,B,C,D	Switch, rotary wafer; SHORT WAVE-BROADCAST	60B461
C-10,13	.005 mfd. 600 V., tubular	46AZ502J	S-2	Switch, slide (spst); NEW-USED BATTERY	60A244
C-14	12 mfd. 150 V., electrolytic	45B194	S-3	Switch, ON-OFF; part of VOLUME control R-5	-----
C-15	.002 mfd. 600 V., tubular	46AZ202J	MISCELLANEOUS PARTS		
C-16	4700 mmf. 500 V., mica	47X35B472K		Cabinet	66A754
C-18	.01 mfd. 600 V., tubular	46AY103J		Clip, mtg.; for dial glass	76A412
RESISTORS					
R-1	47,000 ohms 10%, 1/2 watt; carbon	23X20X473K		Clip, mtg.; for coil L-3	76A326
R-2	2200 ohms 10%, 1/2 watt; carbon	23X20X222K		Clip, mtg.; for transformers T-1 and T-2	76A385
R-3,6	4.7 megohms 10%, 1/2 watt; carbon	23X20X475K		Clip, speed; for mounting front panel	76A413
R-4,9	2.2 megohms 10%, 1/2 watt; carbon	23X20X225K		Dial cord, 57 inches	38A001
R-5	VOLUME control, 1 megohm, includes ON-OFF switch S-3	25B959		Dial scale, glass	22C342
R-7	1 megohm 10%, 1/2 watt, carbon	23X20X105K		Grille assembly	7C318
R-8	5.6 megohms 20%, 1/2 watt, carbon	23X20X565M		Grommet, rubber	16A125
R-10	.75 ohms 10%, 1/2 watt; carbon	23A062		Knob, VOLUME and SHORT WAVE - BROADCAST	15B322
R-11	22,000 ohms 10%, 1/2 watt; carbon	23X20X223K		Knob, TUNING CONTROL	15B323
R-12	330 ohms 10%, 1/2 watt; carbon	23X20X331K		Pointer, dial	82A205
COILS AND TRANSFORMERS					
L-1	Coil, antenna; BC and SW	51B1459	LS-1	Retaining ring; for tuning shaft	76A649
L-2	Coil, oscillator; BC	51B1460		Shaft, tuning	74A500
L-3	Coil, oscillator; SW	51B1461		Speaker, 5" PM; includes output transformer T-3 and plug PL-1	85C085
T-1	Transformer, IF; input	50C233		Spring, dial cord	75A012

MODEL S-80, Defender

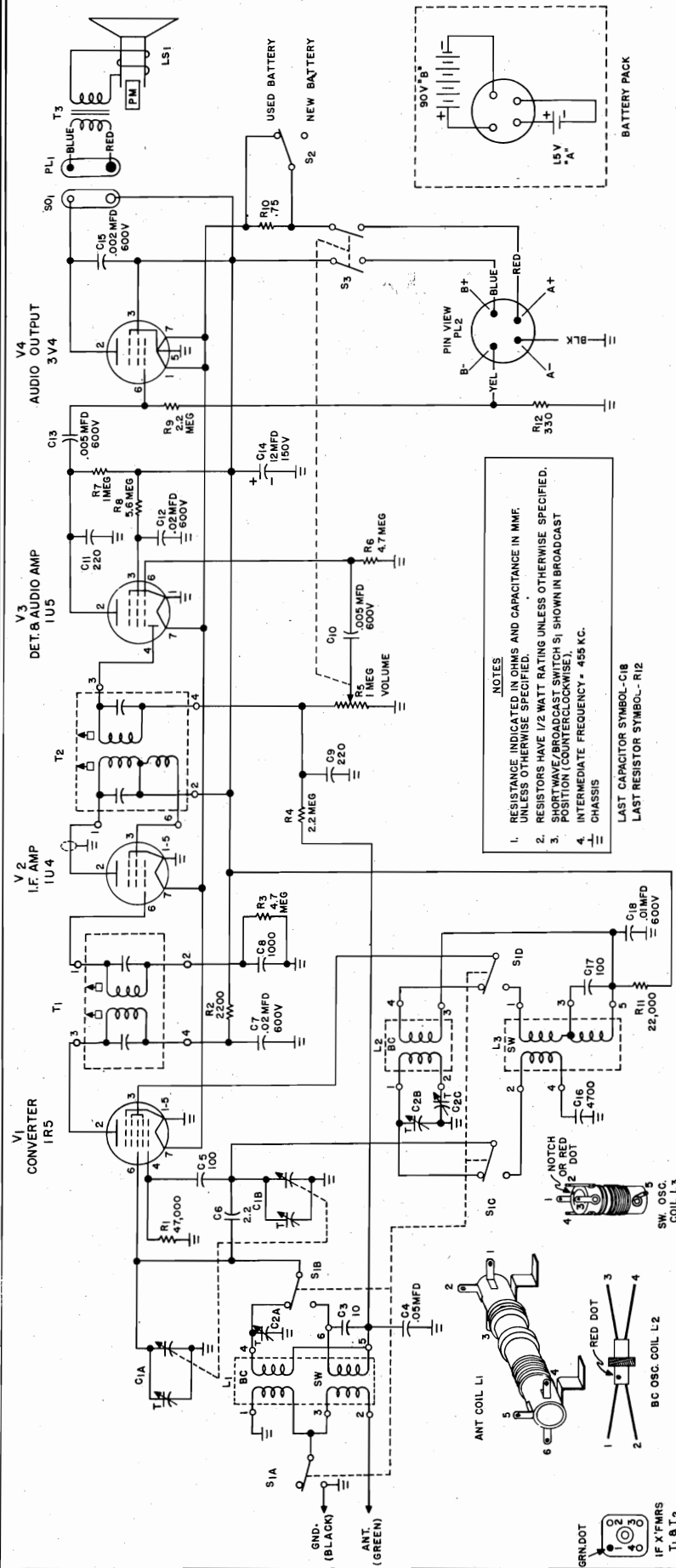

- NOTES**
1. RESISTANCE INDICATED IN OHMS AND CAPACITANCE IN MMF. UNLESS OTHERWISE SPECIFIED.
 2. RESISTORS HAVE 1/2 WATT RATING UNLESS OTHERWISE SPECIFIED.
 3. SHORTWAVE/BROADCAST SWITCH S1 SHOWN IN BROADCAST POSITION (COUNTERCLOCKWISE).
 4. INTERMEDIATE FREQUENCY = 455 KC. CHASSIS
- LAST CAPACITOR SYMBOL - C18
LAST RESISTOR SYMBOL - R12

89D404-A

Fig. 7. Schematic Diagram

- NOTES**
1. SOCKET VIEWS ARE BOTTOM VIEWS.
 2. ALL VOLTAGES ARE MEASURED BETWEEN TUBE SOCKET TERMINALS & CHASSIS WITH ZERO SIGNAL INPUT USING A VACUUM TUBE VOLTMETER.
 3. VOLTAGE MEASURED WITH NEW BATTERY, VOLUME AT MAXIMUM, TUNING GANG FULLY MESHED AND SPEAKER CONNECTED.
 4. ALL VOLTAGES SHOWN ARE DC AND POSITIVE UNLESS OTHERWISE SPECIFIED.
 5. FILAMENT VOLTAGES SHOWN WITH THE BATTERY SAVER AT USED/NEW.
 6. NR - NOT READABLE.
 7. NR - NOT READABLE.
- ⊙ BROADCAST SHORT WAVE
⊙ BROADCAST SHORT WAVE

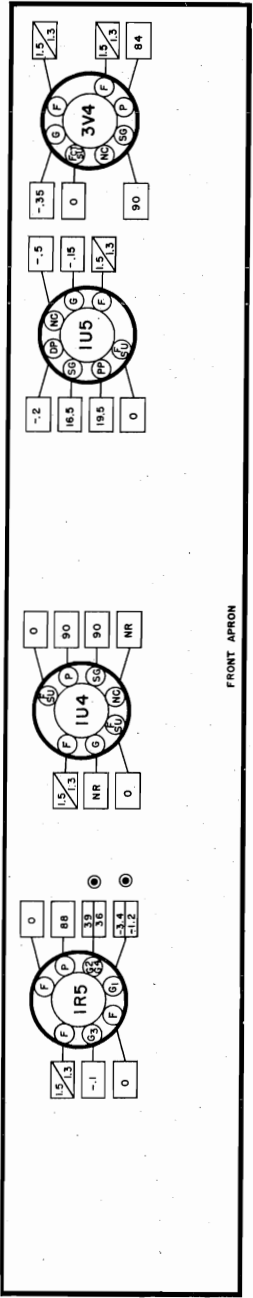

Fig. 8. Tube Socket Voltage Chart

MODELS 5R30, 5R31,
5R32, 5R33, 5R34,
Continental

GENERAL DESCRIPTION

Your Hallicrafters Continental provides reception of both the standard broadcast band and the 6 to 18 megacycle shortwave range. It is a 5 tube superheterodyne radio and is designed to operate from 105 to 125 volt direct current (DC) or 50/60 cycle alternating current (AC).

Fine performance of both standard and shortwave broadcasts can be obtained with the 15 foot antenna wire included with your receiver. It is merely necessary to uncoil this wire, connect one end of it to terminal A1 on the back of the set and then run it about the room in any convenient manner. To complete the antenna installation, the jumper should be connected between terminals A2 and G on the back of the set.

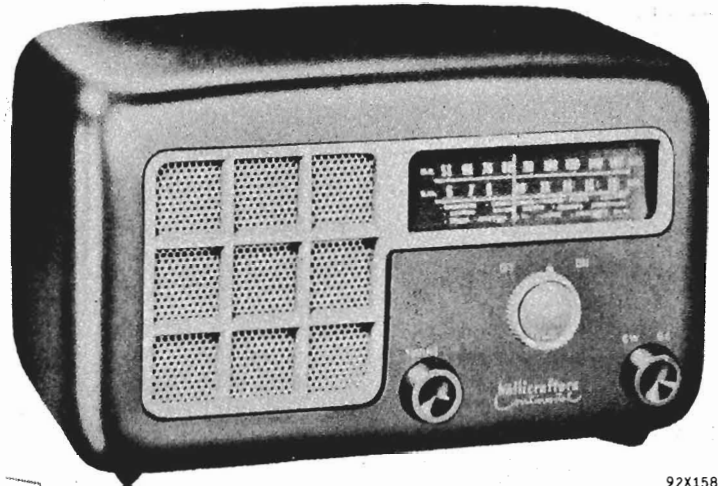

92X1589

HALLICRAFTERS CONTINENTAL
Models 5R30, 5R31, 5R32, 5R33 and 5R34

For your convenience, the principal shortwave stations of the world have been clearly marked on the dial. Since shortwave reception conditions vary with the season of the year and even with the time of day, shortwave programs may not be heard with the same regularity as standard broadcasts. It is important, therefore, that you refer to the table below as it provides an easy means of selecting the shortwave band most suitable to the time of day.

To get the maximum enjoyment from your Hallicrafters radio, carefully follow the instructions contained in this book.

BEST SHORTWAVE RECEPTION TABLE

BAND	MOST FAVORABLE TIME	MOST FAVORABLE DISTANCE
6-7 MC	Night - Winter	Day-400 Miles Night - Over 1500 Miles
9-10 MC	Day - Late Afternoon and Night - Winter	Over 500 Miles
11-12 MC	Evenings or Late Summer Afternoons	Day - Under 1500 Miles Night - Over 1500 Miles
15-18 MC	Early Mornings and Summer Evenings	Over 1500 Miles

INSTALLATION INSTRUCTIONS

UNPACKING - Check all shipping labels and tags for instructions before removing or destroying them.

LOCATION - Do not locate the receiver close to sources of heat such as radiators and heating vents. Allow for proper ventilation of the receiver by placing it at least two or three inches away from the wall.

ANTENNA - The terminals marked A1, A2 and G on the back of the receiver are for antenna and ground connections. Satisfactory results can be obtained in most localities with the 15 foot antenna wire included with your receiver. This wire should be uncoiled for maximum signal pickup. An outside antenna 30 to 60 feet long may be necessary if the receiver is to be operated in a steel constructed building or in an area surrounded by numerous steel structures. The antenna used should be connected to terminal A1 on the antenna terminal strip. The jumper provided on this strip should be connected between terminals A2 and G. In some locations, reception may be improved by connecting a lead from terminal G to a cold water pipe or other good ground.

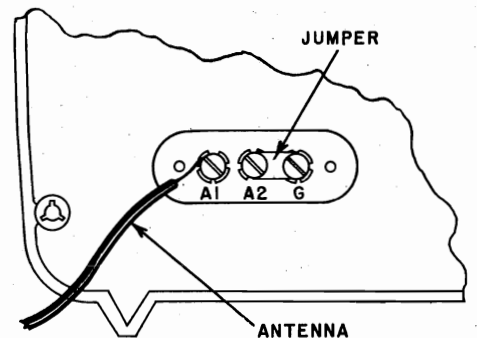

92B1567

Fig. 1. Rear View of Receiver Showing Antenna and Ground Connections

MODELS 5R30, 5R31,
5R32, 5R33, 5R34,
Continental

OPERATING INSTRUCTIONS

TUNING DIAL

1. The standard broadcast band is calibrated in kilocycles with a zero deleted for convenience. To convert the dial reading to the station frequency in kilocycles, add one zero.
2. The shortwave band is calibrated directly in megacycles.

STANDARD BROADCAST AND SHORTWAVE RECEPTION

1. Plug the power cord into a convenient electrical outlet which provides 105 to 125 volts DC or 50/60 cycles AC. If in doubt about your power supply, call your power company before plugging in the receiver. The wrong power source may cause damage to the receiver.
2. Set the SW/BC control to BC for standard broadcast reception or to SW for shortwave reception.
3. Turn the receiver on by turning the VOLUME control clockwise to the ON position. Allow about a minute for the receiver to warm up.

NOTE: If the receiver does not operate after the one minute warm up when connected to a DC source, the power plug should be reversed in the wall outlet to obtain proper polarity.

4. Rotate the VOLUME control clockwise about 1/2 turn as a preliminary setting. Turning this control clockwise increases volume.
5. Tune in the desired station by rotating the TUNING control slowly until the dial pointer indicates the station frequency.
6. After the station has been accurately tuned in, adjust the VOLUME control for the desired volume.
7. To turn the receiver off, turn the VOLUME control counterclockwise to the OFF position.

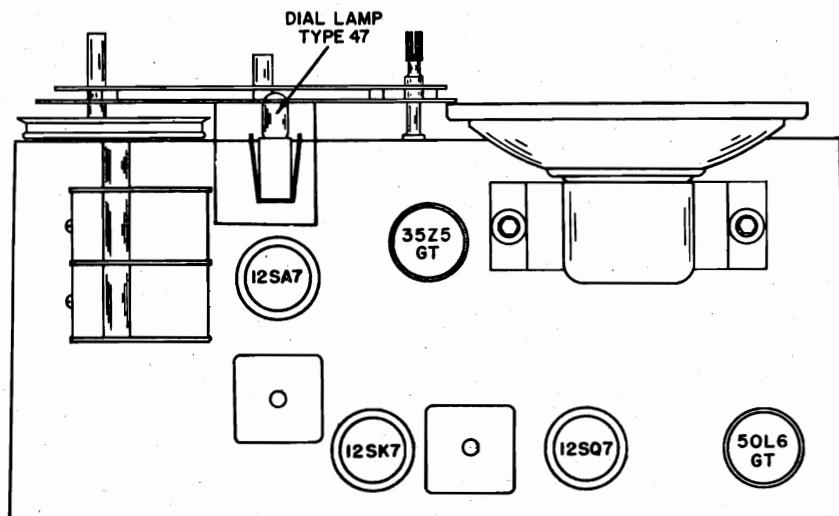

Fig. 2. Top View of Chassis Showing Location of Tubes and Dial Lamp

92C1590

MODELS 5R30, 5R31,
5R32, 5R33, 5R34,
Continental

SERVICE INSTRUCTIONS

SPECIFICATIONS

Tubes 5 including 1 rectifier
Speaker 5 inch PM
Voice Coil Impedance 3.2 ohms
Intermediate Frequency 455 KC
Antenna Single wire or doublet
Power Supply 105-125 volts DC or
50/60 cycles AC
Frequency Coverage 540-1620 KC
and 6-18 MC

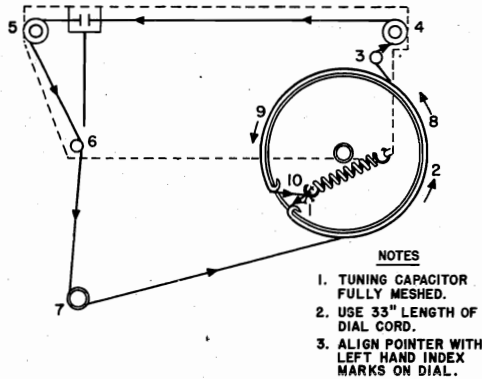

Fig. 3. Dial Cord Stringing Diagram

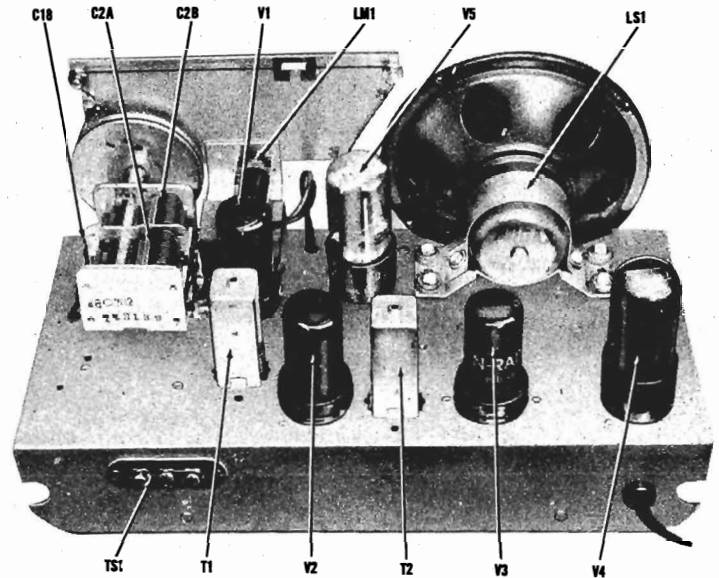

Fig. 4. Top View of Chassis Showing Component Location

TUBE AND DIAL LAMP REPLACEMENT - Refer to Fig. 2. for the location of the tubes and dial lamp used in the receiver. It will be necessary to remove the back cover from the cabinet to gain access to the tubes and dial lamp. To prevent damage to the tuning capacitor, set the TUNING control fully counterclockwise before making any replacement. When replacing tubes, check the tube type carefully and replace it with the correct type. The dial lamp and socket can be removed by compressing the side springs on the socket. Replacement of the dial lamp should be made with a 6-8 volt, Mazda #47 (brown bead) pilot lamp or equivalent.

ALIGNMENT PROCEDURE

- Connect output meter across speaker voice coil.
- Set volume control at maximum.
- Use a non-metallic alignment tool.
- Signal generator must have a modulated output and cover 455 KC, 600 KC, 1300 KC and 14 MC.
- Keep the generator output as low as possible to avoid AVC action.
- Refer to Figs. 6 and 7 for location of alignment adjustments.

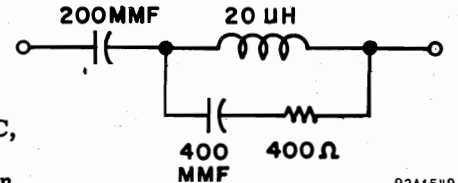

Fig. 5. RTMA Dummy Antenna

STEP	SIGNAL GENERATOR CONNECTIONS	SIGNAL GENERATOR FREQUENCY	BAND SWITCH SETTING	RECEIVER DIAL SETTING	ADJUST FOR MAXIMUM OUTPUT
1	High side to stator plates of rear section of tuning capacitor through a .01 mfd. capacitor. Low side to chassis.	455 KC	BROADCAST	1000 KC	A,B, C,D
2	High side to A1 on antenna terminal strip on rear of chassis through a standard RTMA dummy antenna (Fig.5). Low side to chassis. Connect the jumper between A2 and G.	14 MC	SHORTWAVE	14 MC	E,F
3	Same as STEP 2.	1300 KC	BROADCAST	1300 KC	G,H
4	Same as STEP 2.	600 KC	BROADCAST	600 KC	J

MODELS 5R30, 5R31,
5R32, 5R33, 5R34,
Continental

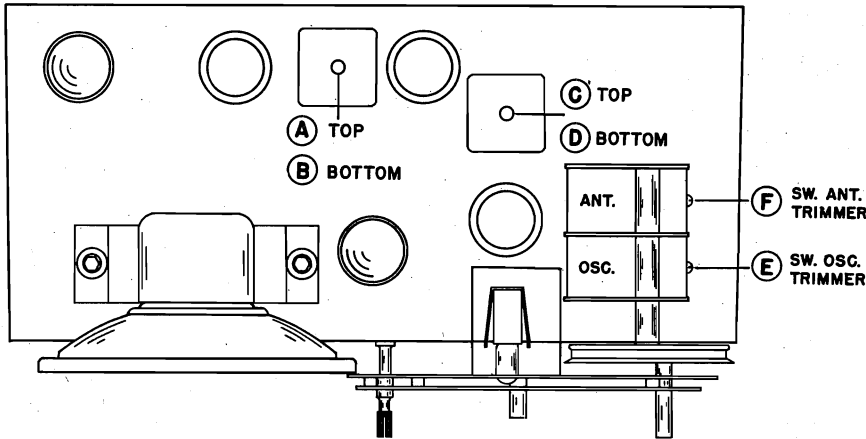

Fig. 6. Top View of Chassis Showing Location of Alignment Adjustments

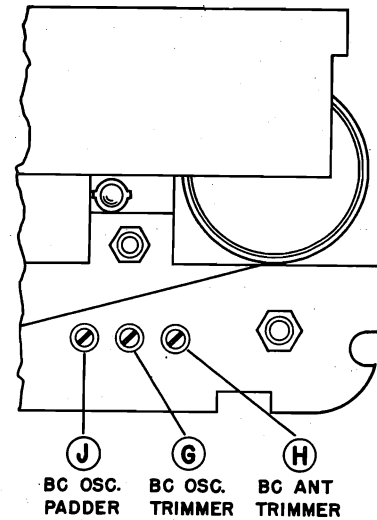

Fig. 7. Front Right View of Chassis Showing Location of Alignment Adjustments

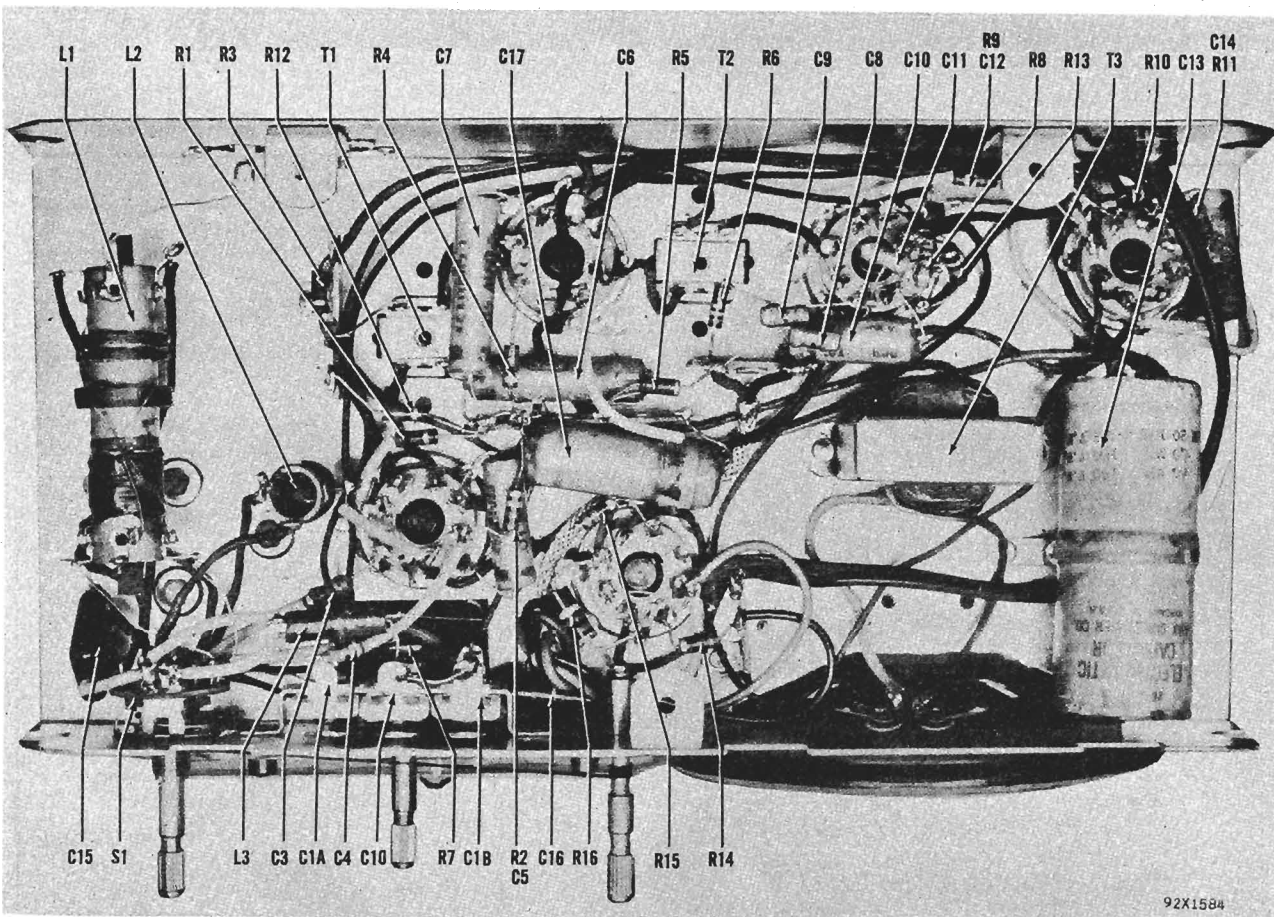
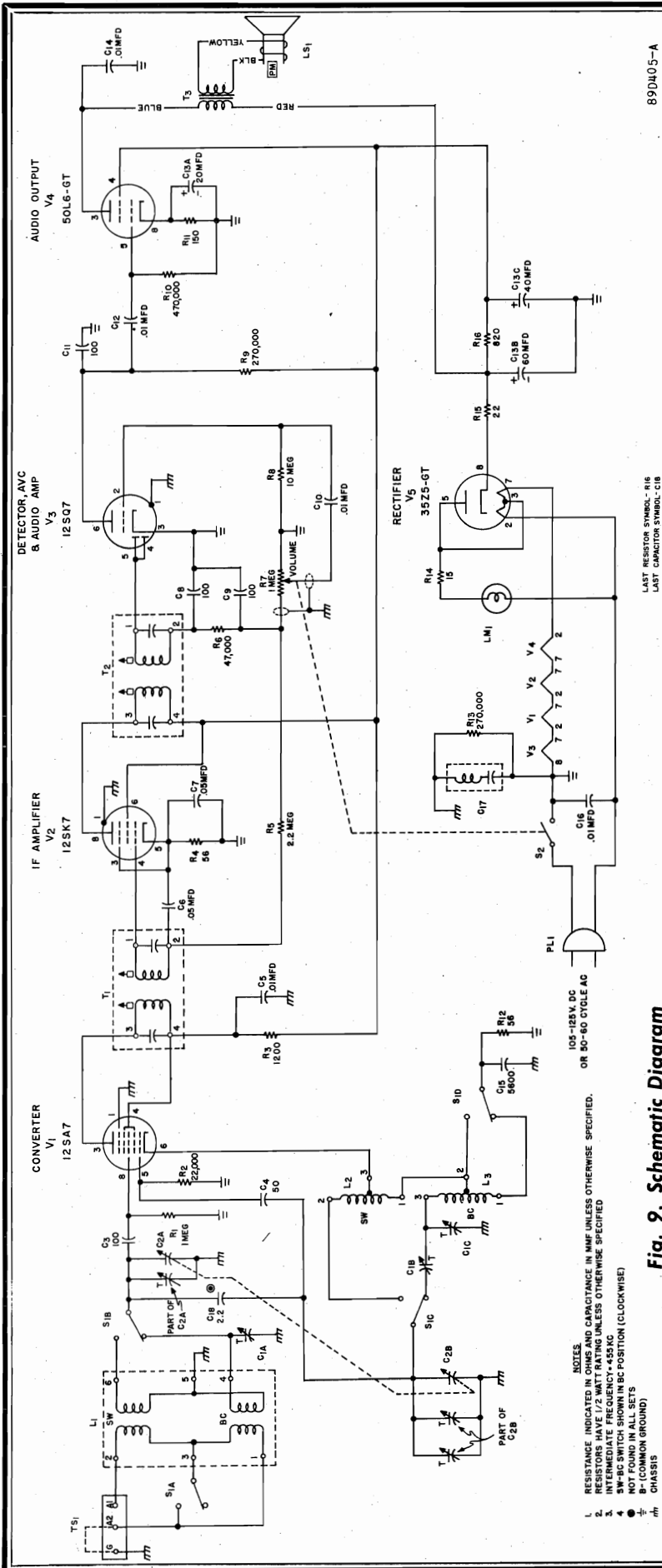

Fig. 8. Bottom View of Chassis Showing Component Location

MODELS 5R30, 5R31,
5R32, 5R33, 5R34,
Continental



89D405-A

LAST RESISTOR SYMBOL - R15
LAST CAPACITOR SYMBOL - C18

Fig. 9. Schematic Diagram

- NOTES
1. RESISTANCE INDICATED IN OHMS AND CAPACITANCE IN MMF UNLESS OTHERWISE SPECIFIED.
 2. RESISTORS HAVE 1/2 WATT RATING UNLESS OTHERWISE SPECIFIED.
 3. INTERMEDIATE FREQUENCY - 455 KC.
 4. PART OF TAP POSITION (CLOCKWISE)
 5. NOT FOUND IN ALL SETS
 6. B - (COMMON GROUND)
 7. CHASSIS

VALUES AND TOLERANCES SHOWN ARE NOMINAL AND VARIATIONS MAY BE FOUND.
IT IS RECOMMENDED THAT THE VALUE OF ANY REPLACEMENT CORRESPOND TO THE
NOMINAL VALUE OF THE PART BEING REPLACED.

Fig. 10. Tube Socket
Voltage Chart

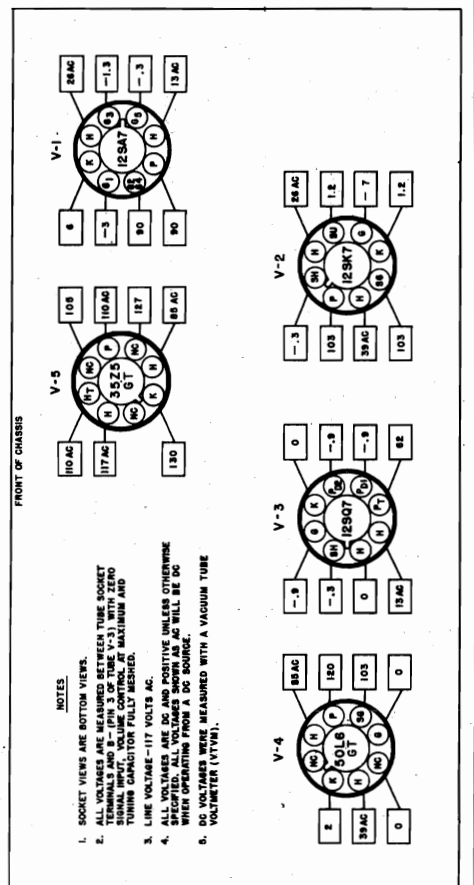

- FRONT OF CHASSIS
- NOTES
1. SOCKET VIEWS ARE BOTTOM VIEWS.
 2. ALL VOLTAGES ARE MEASURED BETWEEN TUBE SOCKET SIGNAL AND COMMON CHASSIS GROUND. SIGNAL AND COMMON CHASSIS GROUND MUST BE FULLY BUSHED AND TUNING CAPACITOR FULLY BUSHED.
 3. ALL VOLTAGES ARE DC AND POSITIVE UNLESS OTHERWISE SPECIFIED. ALL VOLTAGES SHOWN AS AC WILL BE DC UNLESS OTHERWISE SPECIFIED.
 4. DC VOLTAGES WERE MEASURED WITH A VACUUM TUBE VOLTMETER (VTVM).

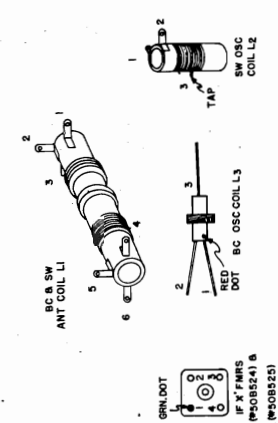

92C1566

MODELS 5R30, 5R31,
5R32, 5R33, 5R34,
Continental

SERVICE PARTS LIST

Schematic Symbol	Description	Hallcrafters Part Number	Schematic Symbol	Description	Hallcrafters Part Number
CAPACITORS					
C-1A,B & C	Trimmer assembly, 3 section	44C408	V-1	12SA7: converter	90X12SA7
C-2	Tuning capacitor, 2 section	48C282	V-2	12SK7: IF amplifier	90X12SK7
C-3,8,9,11	100 mmf. 500 V., ceramic	47X20UJ101K	V-3	12SQ7: detector and audio amplifier	90X12SQ7
C-4	50 mmf. 500 V., ceramic	47X20UJ500K	V-4	50L6: audio output	90X50L6
C-5,10,12,14	.01 mfd. 600 V., tubular paper	46AY103J	V-5	35Z5: rectifier	90X35Z5
C-6,7	.05 mfd. 200 V., tubular paper	46AU503J	MISCELLANEOUS		
C-13A,B & C	20 mfd. 25 V., 60-40 mfd. 150 V.; electrolytic	45B197	Cabinet: Model 5R30 116E003		
C-15	5600 mmf. 500 V., mica	47X30A562	Model 5R31 116E004		
C-16	.01 mfd. 600 V., molded tubular paper	46BR103L6 or 46BR103J6	Model 5R32 116E005		
C-17	Resonant capacitor	46A150	Model 5R33 116E006		
C-18	2.2 mmf. 500 V., bakelite	47A160-4	Model 5R34 116E007		
RESISTORS					
R-1	1 megohm 1/2 watt, carbon	23X20X105M	Cabinet back 8C1657		
R-2	22,000 ohms 1/2 watt, carbon	23X20X223M	Clip, mtg.; for antenna coil L-1 76A879		
R-3	1200 ohms 1/2 watt, carbon	23X20X122M	Clip, mtg.; for IF transformers T-1 and T-2 76A385		
R-4,12	56 ohms 1/2 watt, carbon	23X20X560K	Clip, mtg.; for oscillator coil L-2 76A868		
R-5	2.2 megohms 1/2 watt, carbon	23X20X225M	Dial cord, 30 inches 38A001		
R-6	47,000 ohms 1/2 watt, carbon	23X20X473M	Dial glass 22C349		
R-7	VOLUME control, 1 megohm; includes OFF-ON switch S-2	25B965	Dial light assembly; does not include dial lamp 86A011		
R-8	10 megohms 1/2 watt, carbon	23X20X106M	Escutcheon: Model 5R30 7D349		
R-9,13	270,000 ohms 1/2 watt, carbon	23X20X274M	Models 5R31, 5R32, 5R33 and 5R34 7A352		
R-10	470,000 ohms 1/2 watt, carbon	23X20X474M	Grommet, rubber; for mounting speaker 16A125		
R-11	150 ohms 1/2 watt, carbon	23X20X151K	Grommet, rubber; for mounting tuning capacitor 16A269		
R-14	15 ohms 1/2 watt, carbon	23X20X150M	Knob, VOLUME: Model 5R30 15B477		
R-15	22 ohms 1/2 watt, carbon	23X20X220M	Models 5R31, 5R32, 5R33, and 5R34 15A480		
R-16	820 ohms 1 watt, carbon	23X30X821M	Knob, TUNING and SW-BC: Model 5R30 15B478		
COILS AND TRANSFORMERS					
L-1	Coil, antenna; BC and SW	51B1494	Model 5R31 15B481		
L-2	Coil, oscillator; SW	51B1493	Model 5R32 15B482		
L-3	Coil, oscillator; BC	51B1495	Model 5R33 15B483		
T-1	Transformer, IF; input	50B524	Model 5R34 15B484		
T-2	Transformer, IF; output	50B525	PL-1	Line cord and plug	87A078
T-3	Transformer, audio output	55C181	LM-1	Lamp, dial; Mazda #47	39A004
SWITCHES					
S-1A,B,C & D	Switch, rotary; SW-BC	60B472	Lock, line cord; male 76A397-1		
S-2	Switch, OFF-ON; part of VOLUME control R-7	-----	Lock, line cord; female 76A397-2		
TUBES AND RECTIFIERS					
MISCELLANEOUS					

MODELS 5R50, 5R51,
5R52, Runs 1, 2

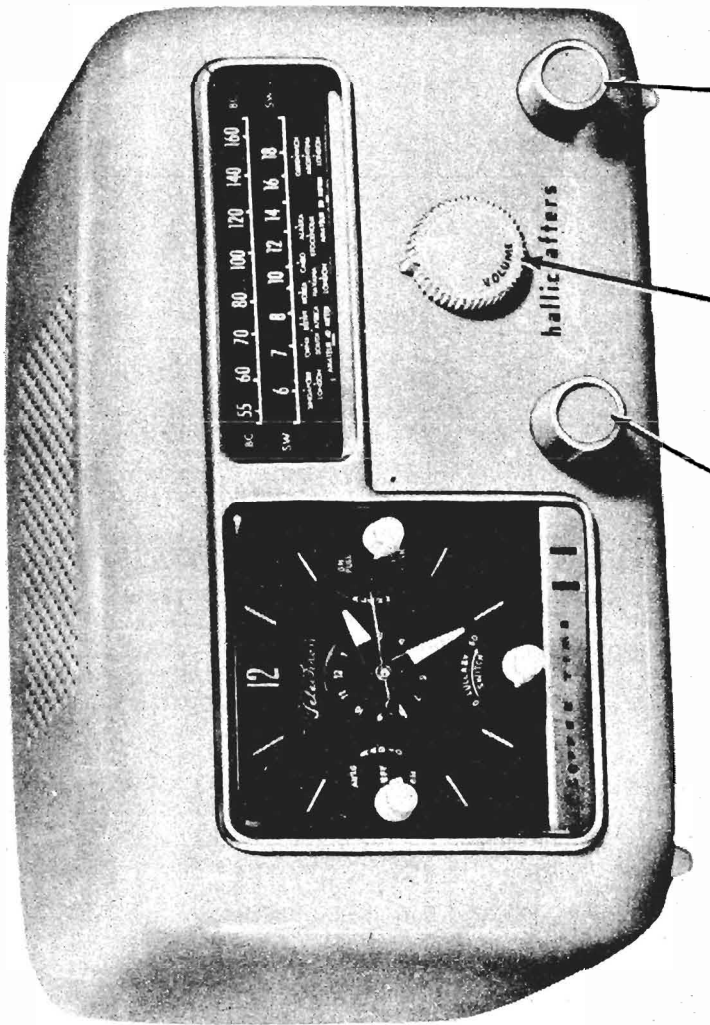

TUNING **ON-OFF /** **BAND SWITCH**
VOLUME **SW - BC**

Fig. 1. Hallicrafters Clock Radio Models 5R50 — Aqua Blue, 5R51 — Minosa Yellow, 5R52 — Shell Pink
For operating convenience the principal short wave stations of the world have been clearly marked on the dial. Since short wave receiving conditions vary with the time of day and the season of the year short wave programs may not be heard with the same regularity as standard broadcasts. It is important, therefore, that you refer to the table on page 3 as it provides a simple method of selecting the short wave band most suitable for any given time and season.

BEST SHORTWAVE RECEPTION TABLE

Band	Most Favorable Time	Most Favorable Distance
6-7 MC	Night - Winter	Day-400 Miles Night - Over 1500 Miles
9-10 MC	Day-Late Afternoon and Night-Winter	Over 500 Miles
11-12 MC	Evenings or Late Summer Afternoons	Day - Under 1500 Miles Night - Over 1500 Miles
15-18 MC	Early Mornings and Summer Evenings	Over 1500 Miles

MODELS 5R50, 5R51,
5R52, Runs 1, 2

INSTALLATION INSTRUCTIONS

UNPACKING - Observe all shipping labels and tags for instructions before removing or destroying them.

LOCATION - Your Hallicrafters Clock Radio should be placed in a convenient location away from radiators or other hot air sources. It should be positioned at least 2 inches from the wall to permit proper air circulation.

POWER SOURCE - The power plug should be inserted into a power outlet that will supply 105 to 125 volts 60 cycle AC ONLY. If in doubt about your power supply, call your power company before connecting the receiver. The wrong source of power may cause serious damage to both the radio receiver and the clock motor.

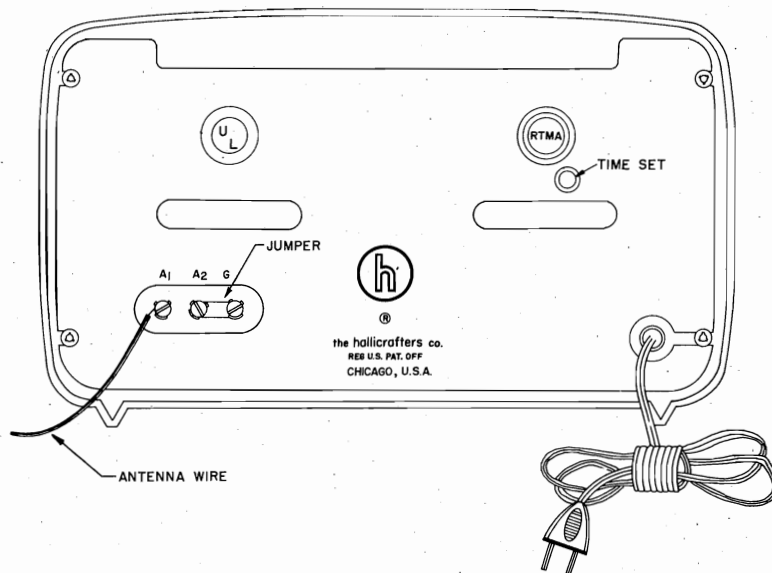

Fig. 2. Rear View Showing Antenna Connections and "Time Set" Knob

ANTENNA - The terminals marked A1, A2 and G on the back of the receiver are for antenna and ground connections. Satisfactory results can be obtained in most localities with the 15 foot antenna wire included with your receiver. This wire should be uncoiled for maximum signal pickup. An outside antenna 30 to 60 feet long may be necessary if the receiver is to be operated in a steel constructed building or in an area surrounded by numerous steel structures. The antenna used should be connected to terminal A1 on the antenna terminal strip. The jumper provided on this strip should be connected between terminals A2 and G. In some locations, reception may be improved by connecting a lead from terminal G to a cold water pipe or other good ground.

CLEANING - The cabinet, dial glass, and clock face should be cleaned with mild soap and water taking care to prevent excess moisture from entering the cabinet. Chemical cleaning solutions should not be used on your Hallicrafters Clock Radio.

OPERATING INSTRUCTIONS

CLOCK - Your clock will start automatically as soon as the power cord is plugged into the proper outlet. The correct time may be set by rotating the **TIME SET** knob that protrudes from the rear of the cabinet. The self starting feature will re-start the clock if there is a temporary interruption of the electric power.

ELECTRIC ALARM - The control regulating the electric alarm is located at the "three o'clock" position on the clock face. To set the alarm pull the knob to the "OUT" position and rotate the knob in the counterclockwise direction until the desired alarm time appears under the pointer near the center of the clock face. Leave the knob in the "OUT" position. When the alarm rings it may be turned off simply by pushing the control knob. If the alarm is not turned off after sounding for about forty five minutes it will turn off automatically.

Fig. 3. Clock Face Showing Controls and "Coffee Time" Outlet

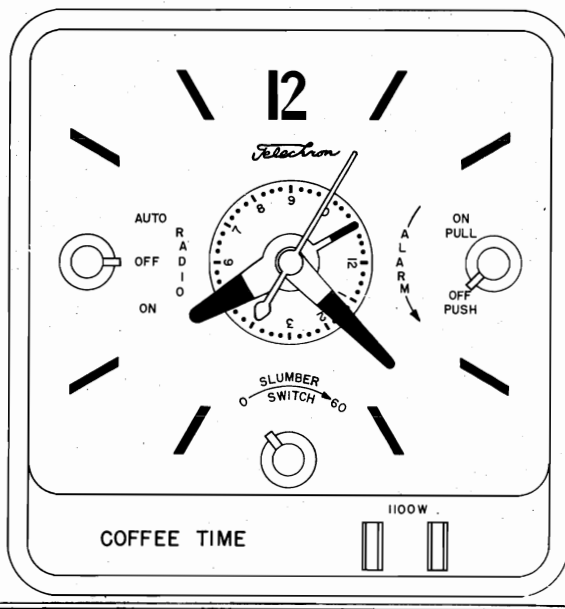

IMPORTANT

The alarm will begin to sound approximately ten minutes later than the time indicated on the alarm set dial. This period is to allow for a time difference between the turning on of the radio and "coffee time" appliance outlet and the sounding of the alarm. Refer to the instructions below.

RADIO AND "COFFEE TIME" APPLIANCE OUTLET— The RADIO switch, located at the "nine o'clock" position on the clock face, controls the mode of operation of the radio and the "coffee time" appliance outlet. When this switch is set to the "OFF" position neither radio nor outlet will operate. When set to the "ON" position the outlet will supply power and the radio may be operated by advancing the OFF-VOLUME control. When set to the "AUTOMATIC" position both radio and outlet will turn on automatically at the time to which the alarm has been set. If the alarm control has been left in the "OUT" position the alarm will begin to sound ten minutes later.

SLUMBER SWITCH— The SLUMBER switch, located at the "six o'clock" position on the clock face, may be used to turn the radio and/or the "coffee time" appliance outlet off automatically after operation for any desired period of time up to one hour. The SLUMBER switch will operate only when the RADIO switch is set to either the "OFF" or to the "AUTOMATIC" position. Operation of the SLUMBER switch is accomplished simply by advancing the knob until the pointer is at a position corresponding to the number of minutes that operation of the radio or outlet is desired. For example if you desire the radio to operate for one hour and then shut off advance the SLUMBER switch all of the way to the "60" position. If only 30 minutes operation is desired advance the SLUMBER switch only to the half way position, etc.

For your convenience in becoming acquainted with the use of the various controls the following table has been provided showing the proper control position for various types of operation.

TABLE 1, SHOWING OPERATING POSITIONS

MODE OF OPERATION	SET EACH CONTROL TO THE POSITION INDICATED AND FOLLOW THE SIMPLE INSTRUCTIONS				
	RADIO CONTROL	ALARM CONTROL	SLUMBER SWITCH	RADIO OFF-VOLUME CONTROL	"COFFEE TIME" OUTLET WILL BE:
To operate the radio manually	On	In	Off	On	On
To turn the radio on automatically at a desired time	Automatic	Set for desired time and push in	Off	On	Off, but will turn on with the radio
To sound the alarm only at a desired time	Off	Set for ten minutes earlier than the desired time and leave out.	Off	Off	Off
To automatically turn on the radio at a desired time and sound the alarm ten minutes later	Automatic	Set for desired time and leave out	Off	On	Off, but will turn on with the radio
To automatically turn on the "Coffee Time" outlet only at a desired time and sound the alarm ten minutes later	Automatic	Set for desired time and leave out	Off	Off	Off, but will turn on at the desired time
To automatically turn off the radio and "Coffee Time" outlet after operating for any desired length of time up to one hour	Off	In	Set for desired length of operating time	On	On, but will turn off with the radio
To automatically turn off the radio and "Coffee Time" outlet after operation for any desired period of time (up to one hour) and to turn them on again automatically at a later time (up to twelve hours) and to sound the alarm ten minutes later	Automatic	Set for the desired "TURN ON" time and leave out	Set for desired length of operating time before turning off	On	On, then off, then on, automatically

MODELS 5R50, 5R51,
5R52, Runs 1, 2

RADIO OPERATION IMPORTANT

Before operating the radio be sure that the clock controls are set to an appropriate position. Refer to the above table. The radio will not operate if the RADIO switch on the clock face is set to the "OFF" position and may not operate if this switch is set to the "AUTOMATIC" position.

TUNING DIAL - The standard broadcast band is calibrated in kilocycles with the last zero deleted for convenience in reading the dial. To convert the dial reading to the station frequency in kilocycles simply add one zero.

The short wave band is calibrated directly in megacycles.

STANDARD BROADCAST AND SHORTWAVE RECEPTION - Turn the BAND SWITCH (right hand knob) clockwise for standard broadcast reception and counterclockwise for short wave reception.

The OFF-VOLUME control (large center knob) turns the receiver on and off and also controls the volume. Turn this knob in the clockwise direction to turn the receiver on and to increase volume. Allow about sixty seconds for the set to warm up.

Tune in the desired station with the TUNING control (left hand knob).

After the desired station has been tuned readjust the VOLUME control as desired.

The receiver may be turned off either by turning the OFF-VOLUME control to the extreme counterclockwise position (until a click is heard) or by setting the RADIO switch, located at the "nine o'clock" position on the clock face, to the "OFF" position.

SERVICE INSTRUCTIONS

SPECIFICATIONS

- Tubes 5 including 1 rectifier
- Speaker 5 inch PM
- Voice Coil Impedance 3.2 ohms
- Intermediate Frequency 455 KC
- Antenna Single wire or doublet
- Power Supply 105-125 volts
60 cycles AC only
- Frequency Coverage. 540-1620 KC
and 6-18 MC

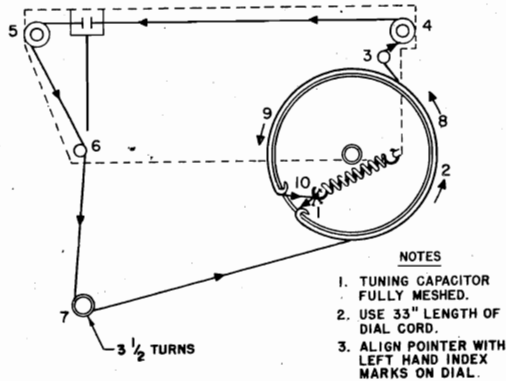

Fig. 4. Dial Cord Stringing Diagram 92C1569-A

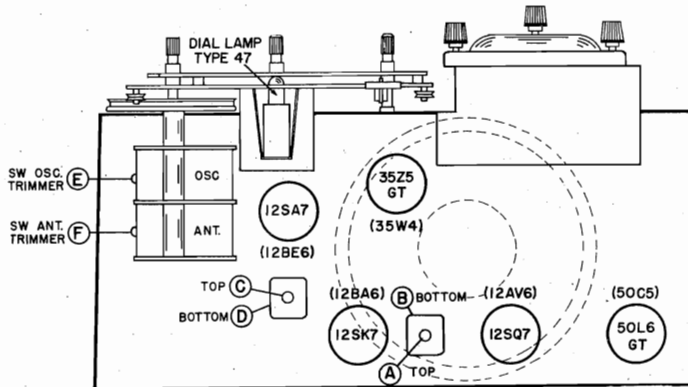

Fig. 5. Top View of Chassis Showing Location of Tubes and Alignment Adjustments

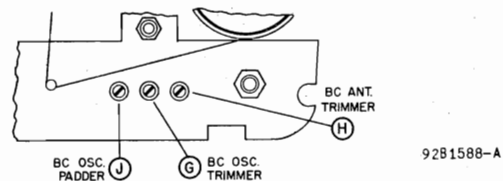

Fig. 6. Front View of Chassis Showing Location of Alignment Adjustments 92B1588-A

TUBE AND DIAL LAMP REPLACEMENT - Refer to Fig. 5. for the location of the tubes and dial lamp used in the receiver. It will be necessary to remove the back cover from the cabinet to gain access to the tubes and dial lamp. To prevent damage to the tuning capacitor, set the TUNING control fully counterclockwise before making any replacement. When replacing tubes, check the tube type carefully and replace it with the correct type. The dial lamp and socket can be removed by compressing the side springs on the socket. Replacement of the dial lamp should be made with a 6-8 volt, Mazda #47 (brown bead) pilot lamp or equivalent.

MODELS 5R50, 5R51,
5R52, Runs 1, 2

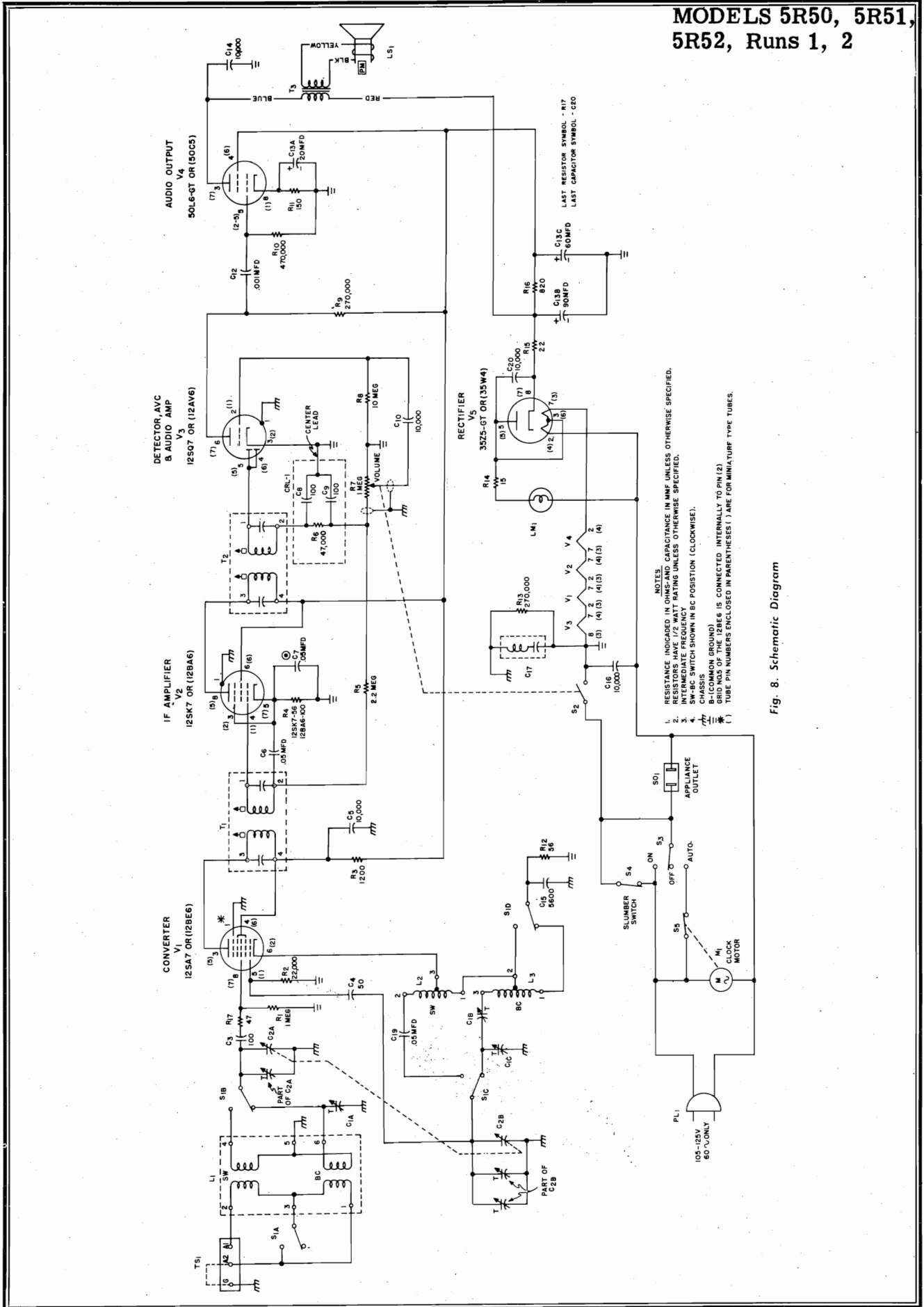

Fig. 8. Schematic Diagram

MODELS 5R50, 5R51,
5R52, Runs 1, 2

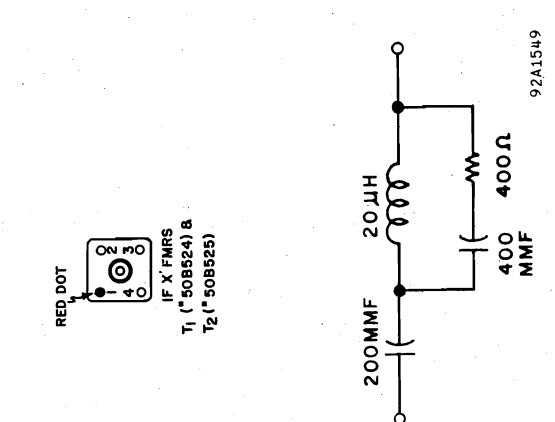
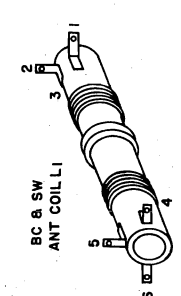
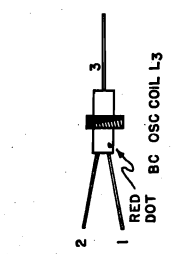
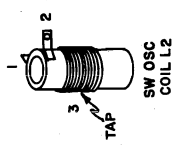

Fig. 7. RTMA Dummy Antenna



ALIGNMENT PROCEDURE

- Connect output meter across speaker voice coil.
- Set volume control at maximum.
- Use a non-metallic alignment tool.
- Signal generator must have a modulated output and cover 455 KC, 600 KC, 1300 KC and 14 MC.
- Keep the generator output as low as possible to avoid AVC action.
- Refer to Figs. 5 and 6 for location of alignment adjustments.

STEP	SIGNAL GENERATOR CONNECTIONS	SIGNAL GENERATOR FREQUENCY	BAND SWITCH SETTING	RECEIVER DIAL SETTING	ADJUST FOR MAXIMUM OUTPUT
1	High side to stator plates of rear section of tuning capacitor through a .01 mfd. capacitor. Low side to chassis.	455 KC	BROADCAST	1000 KC	A,B, C,D
2	High side to A1 on antenna terminal strip on rear of chassis through a standard RTMA dummy antenna (Fig.7). Low side to chassis. Connect the jumper between A2 and G.	14 MC	SHORTWAVE	14 MC	E,F
3	Same as STEP 2.	1300 KC	BROADCAST	1300 KC	G,H
4	Same as STEP 2.	600 KC	BROADCAST	600 KC	J

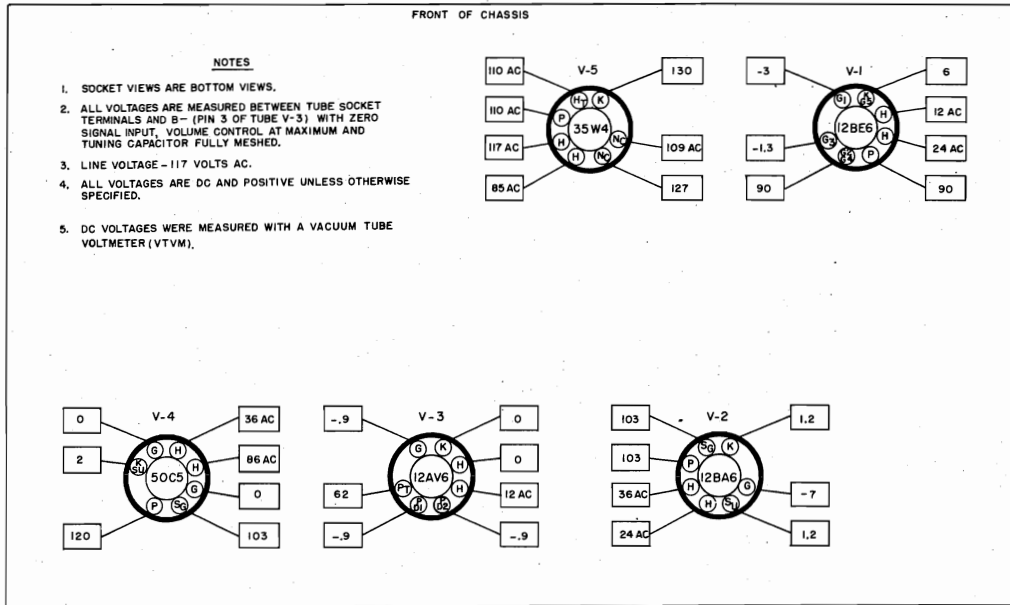

Fig. 9. Tube Socket Voltage Chart for Chassis Using Miniature Tubes

92C1703

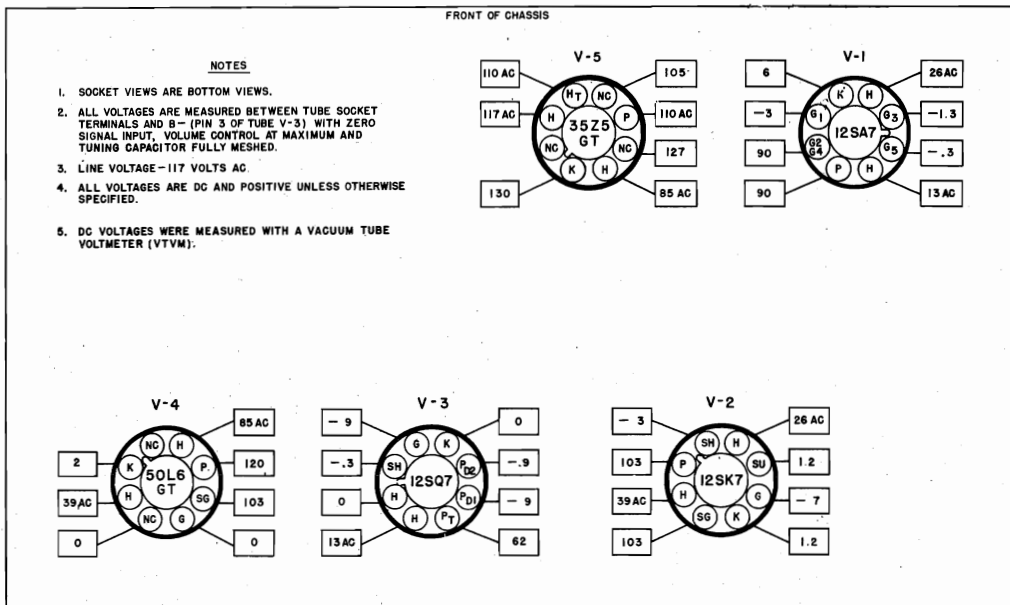

Fig. 10. Tube Socket Voltage Chart for Chassis Using Octal Tubes

92C1566

MODELS 5R50, 5R51,
5R52, Runs 1, 2

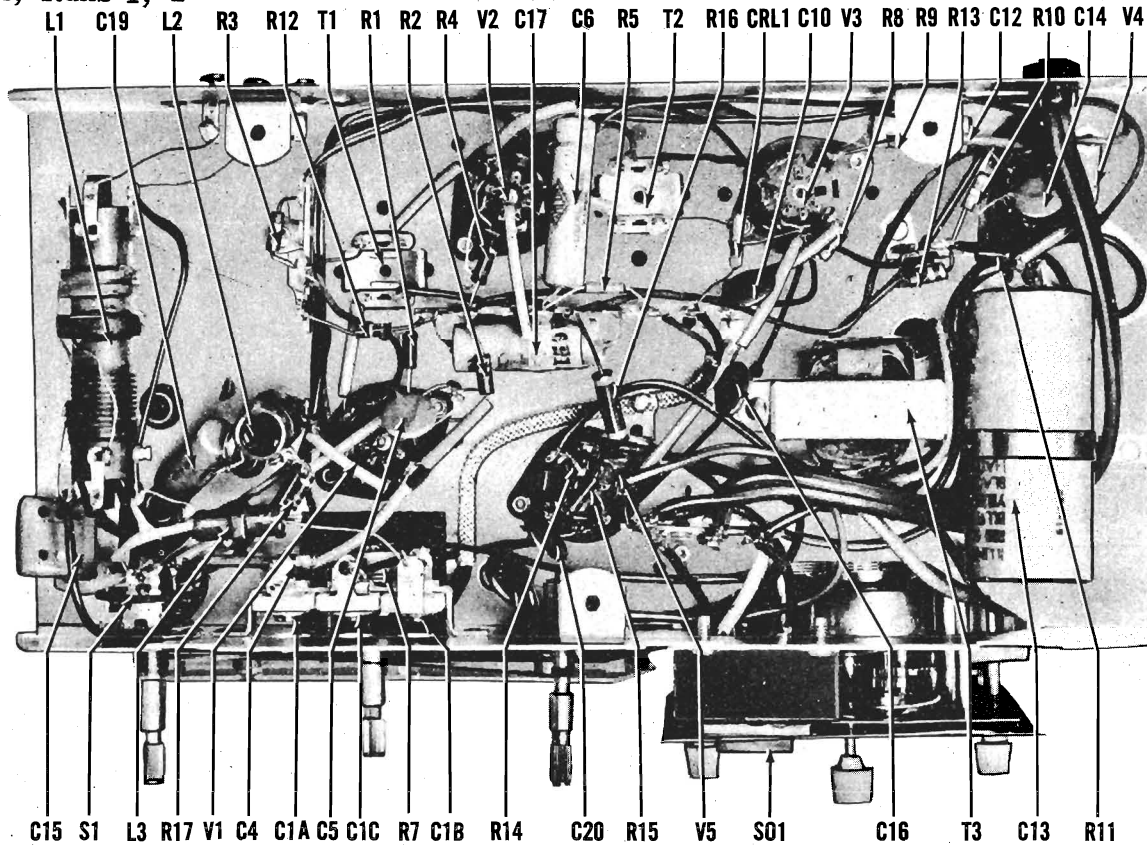

Fig. 11. Bottom View of Chassis Showing Component Location

92X1754

(Chassis Using Miniature Tubes)

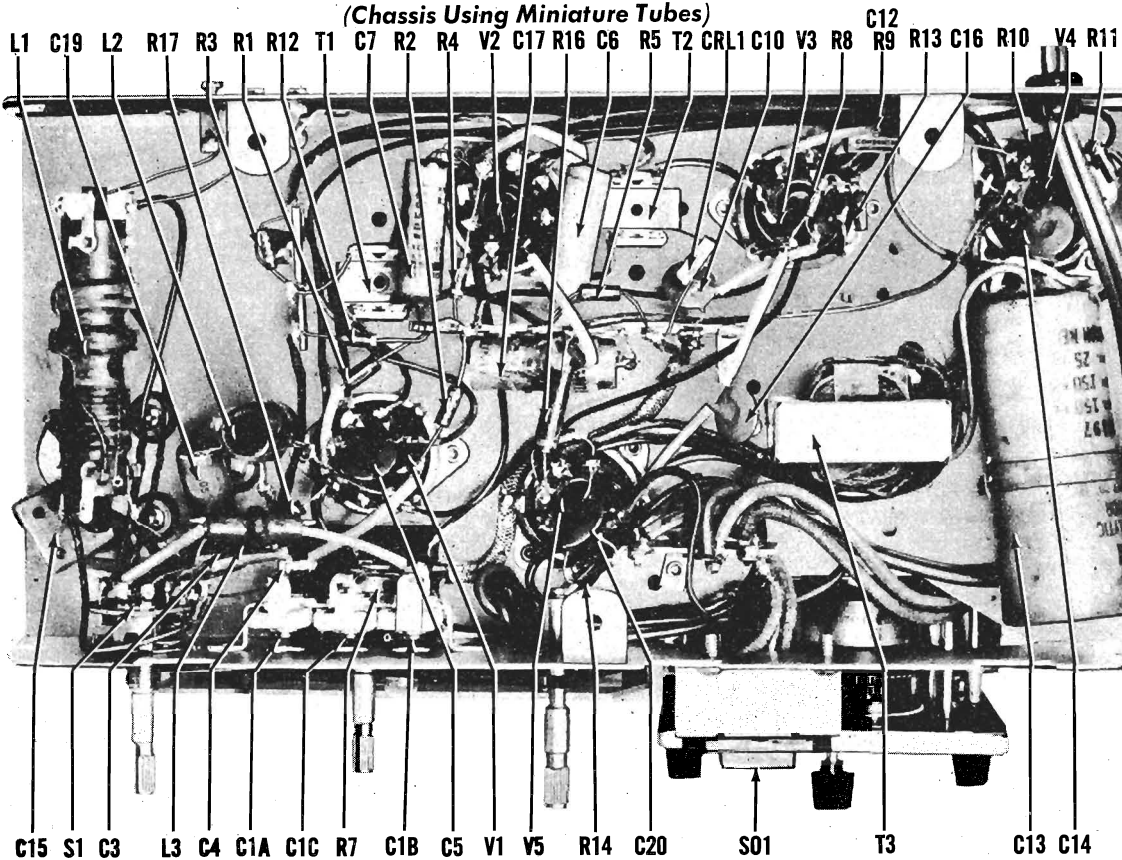

Fig. 12. Bottom View of Chassis Showing Component Location
(Chassis Using Octal Tubes)

Schematic Symbol	Description	Hallcrafters Part Number	Schematic Symbol	Description	Hallcrafters Part Number
CAPACITORS			TUBE COMPLEMENT (OCTAL) (Cont.)		
C-1A, B & C	Trimmer assembly, 3 section	44C408	V-4	50L6GT: audio output	90X50L6GT
C-2A & B	Tuning capacitor, 2 section	48C282	V-5	35Z5GT: rectifier	90X35Z5GT
C-3	100 mmf. 500 V., ceramic	47X20UJ101K	TUBE COMPLEMENT (MINIATURE)		
C-4	50 mmf. 500 V., ceramic	47X20UJ500K	V-1	12BE6: converter	90X12BE6
C-5, 10, 14, 16, 20	10,000 mmf. 450 V., ceramic disc	47A217	V-2	12BA6: IF amplifier	90X12BA6
C-6, 7, 19	.05 mfd. 200 V., tubular paper	46AU503J	V-3	12AV6: detector and audio amplifier	90X12AV6
C-8, 9	100 mmf. (part of diode filter network CRL-1)	-----	V-4	50C5: audio output	90X50C5
C-12	.001 mfd. 600 V., tubular paper	46AZ102J	V-5	35W4: rectifier	90X35W4
C-13A, B & C	20 mfd. 25 V., 90-60 mfd. 150 V.; electrolytic	45B197	MISCELLANEOUS		
C-15	5600 mmf. 500 V., mica	47X30A562K	SO-1	AC Receptacle Cabinet:	10A496
C-17	Resonant capacitor	46A150		Model 5R50 (Aqua Blue)	116E009
RESISTORS				Model 5R51 (Minosa Yellow)	116E010
R-1	1 megohm 1/2 watt, carbon	23X20X105M		Model 5R52 (Shell Pink)	116E011
R-2	22,000 ohms 1/2 watt, carbon	23X20X223M		Cabinet back	8C1657
R-3	1200 ohms 1/2 watt, carbon	23X20X122M		Clip, mtg.; for antenna coil L-1	76A879
R-4	56 ohms 1/2 watt, carbon (used with 12SK7)	23X20X560K		Clip, mtg.; for IF transformers T-1 and T-2	76A385
R-4	100 ohms 1/2 watt, carbon (used with 12BA6)	23X20X101K		Clip, mtg.; for oscillator coil L-2	76A868
R-5	2.2 megohms 1/2 watt, carbon	23X20X225M		Clock Unit	80D117
R-6	47,000 ohms (part of diode filter network CRL-1)	-----		Dial cord (specify length)	38A026
R-7	VOLUME control, 1 megohm; includes OFF-ON switch S-2	25B965		Dial glass	22C349
R-8	10 megohms 1/2 watt, carbon	23X20X106M		Dial light assembly; does not include dial lamp	86A011
R-9, 13	270,000 ohms 1/2 watt, carbon	23X20X274M	CRL-1	Diode filter network (includes R-6, C-8 and C-9)	49A016
R-10	470,000 ohms 1/2 watt, carbon	23X20X474M		Escutcheon	7D369
R-11	150 ohms 1/2 watt, carbon	23X20X151K		Grill cloth	14B326
R-12	56 ohms 1/2 watt, carbon	23X20X560K		Grommet, rubber	16A125
R-14	15 ohms 1/2 watt, carbon	23X20X150M		Knob, VOLUME	15B477
R-15	22 ohms 1/2 watt, carbon	23X20X220M		Knob, clock	15B504
R-16	820 ohms 1 watt, carbon	23X30X821M		Knob, TUNING and SW-BC:	
R-17	47 ohms 1/2 watt, carbon	23X20X470K		Model 5R50 (Blue)	15B505
COILS AND TRANSFORMERS				Model 5R51 (Yellow)	15B506
L-1	Coil, antenna; BC and SW	51B1494	PL-1	Model 5R52 (Pink Beige)	15B507
L-2	Coil, oscillator; SW	51B1493	LM-1	Line cord and plug	87B3577
L-3	Coil, oscillator; BC	51B1495		Lamp, dial; Mazda #47	39A004
T-1	Transformer, IF; input	50B524		Lock, line cord	76A953
T-2	Transformer, IF; output	50B525		Pointer, dial	82A211
T-3	Transformer, audio output	35C187		Shaft, tuning	74B511
SWITCHES				Socket, tube; miniature (with center shield)	6B402
S-1A, B, C & D	Switch, rotary; SW-BC	60B472		Socket, tube; miniature (without center shield)	6B314
S-2	Switch, OFF-ON; part of VOLUME control R-7	-----	LS-1	Socket, tube; octal	6A250
TUBE COMPLEMENT (OCTAL)				Spring, dial cord	75A012
V-1	12SA7: converter	90X12SA7	LS-1	Speaker, 5 inch PM (Run 1)	85C110
V-2	12SK7: IF amplifier	90X12SK7		Bracket, speaker mtg. (Run 1)	67A570
V-3	12SQ7: detector and audio amplifier	90X12SQ7	LS-1	Bracket, speaker mtg. (Run 1) 1 13/16" dia. x 2 7/8" high	67B1921
			TS-1	Speaker, 5 inch PM (Run 2)	85C140
				Plate, speaker mtg. (Run 2)	63B849
				Bracket, speaker mtg. (Run 2)	67B2026
				Terminal strip, antenna	88A032

GENERAL DESCRIPTION

World-wide radio reception is yours with the Hallicrafters Model S-38C. This 5 tube communications receiver tunes from 540 kilocycles to 32 megacycles to bring you standard broadcast programs, foreign and domestic shortwave broadcasts, amateurs, police, ships, aircraft and countless other exciting distant stations. It receives both voice and code broadcasts and is designed to operate from 105 to 125 volt direct current (DC) or 60 cycles alternating current (AC). A 5-inch Alnico V permanent magnet speaker is built into the top of the cabinet and tip jacks have been provided on the back of the set for plugging in a pair of headphones. The RECEIVE-STANDBY switch on the front panel is a special feature which permits you to silence the receiver without turning the set off.



Hallicrafters Model S-38C

Good reception of both standard and shortwave broadcasts can be obtained in most localities with the 15 foot antenna wire included with your receiver. It is merely necessary to uncoil this wire, connect one end of it to terminal A1 on the back of the set and then run it about the room in any convenient manner. To complete the antenna installation, connect the jumper between terminals A2 and G.

Your set is provided with two tuning knobs for greater ease of tuning. Wide tuning is done with the knob marked TUNING and fine tuning with the knob marked BAND SPREAD. The BAND SPREAD knob permits you to accurately tune in stations on crowded bands by spreading them out so that they may be more easily separated. In this way you are able to hear many more stations than you would on an ordinary radio with just one tuning knob.

The amateur bands and principal shortwave channels of the world are clearly marked on the dial for your convenience. Since shortwave conditions vary with the season of the year and even with the time of day, shortwave programs may not be heard with the same regularity as standard broadcasts. A special table has been provided on page 3 to aid you in determining the most favorable times for shortwave listening.

INSTALLATION INSTRUCTIONS

ANTENNA - The terminals marked A1, A2 and G on the back of the set are for antenna and ground connections. Good results can be obtained in most localities with the 15 foot antenna wire included with your receiver. This wire should be uncoiled to provide maximum signal pickup. An outside antenna 50 to 100 feet long (ordinary copper wire) may be necessary if the receiver is operated in a difficult reception area or steel constructed building. Connect the antenna wire to terminal A1 on the back of the set and then connect the jumper between terminals A2 and G. In some locations, reception may be improved by connecting a lead from terminal G to a cold water pipe or outside ground rod.

For really top performance, there is no substitute for an outside antenna such as used by the commercial radio stations. Provision has been made on your receiver for the connection of this type of antenna, commonly called a doublet. When a doublet antenna is used, the jumper is removed and the antenna is connected to terminals A1 and A2. Consult your radio dealer for further information.

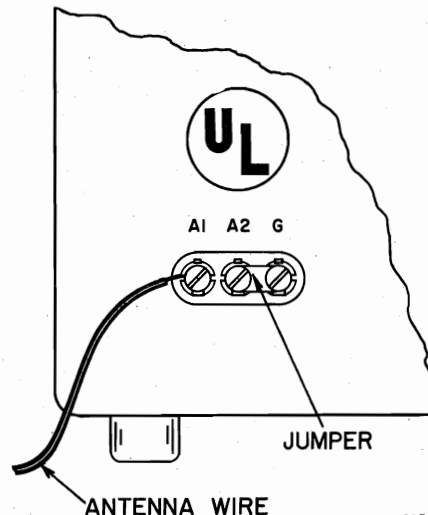

Fig. 1. Rear View of Receiver Showing Antenna and Ground Terminals

OPERATING INSTRUCTIONS

TUNING DIAL - All dial readings are in megacycles. To convert the readings on the standard broadcast band (band 1) to kilocycles, simply remove the dot and add two zeros; thus, .7 on the dial corresponds to 700 kilocycles.

AM-CW SWITCH - Set this switch at AM to listen to voice and musical broadcasts. Set it at CW only if you wish to hear code signals.

SPEAKER-PHONES SWITCH - For operation of the built-in speaker, set the switch at SPEAKER. Tip jacks are provided on the back of the set for plugging in a pair of headphones. Use any 500 to 5000 ohm headphones. For headphone operation set the switch at PHONES.

BAND SELECTOR CONTROL- Set this control for the band you wish to tune.

VOLUME CONTROL - Turn this control clockwise to turn the set on. Allow about 30 seconds for the tubes to reach operating temperature and then advance the control to increase volume. To turn the set off, turn this control counter-clockwise until a click is heard.

NOTE - If the receiver does not operate after the 30 second warm up when connected to a DC source, the power plug should be reversed in the wall outlet to obtain proper polarity.

RECEIVE - STANDBY SWITCH - Set this switch at RECEIVE for radio reception. If you wish to silence the receiver without turning the set off, set the switch at STANDBY. To resume radio reception, simply return the switch to the RECEIVE position.

TUNING KNOB - Your receiver has been provided with two tuning knobs - The TUNING knob which operates the pointer on the left hand dial and a separate BAND SPREAD knob which operates the pointer on the right hand dial. The TUNING knob is for wide tuning and the BAND SPREAD knob for fine tuning. Use the TUNING knob to tune in the desired station. Tune for the clearest and strongest signal. If the signal is too strong, reduce it by means of the VOLUME control, not by using the TUNING knob. For code reception, adjust the TUNING knob for the desired pitch of the CW code signal when tuning in the station.

IMPORTANT - The dial readings will correspond to the exact station frequencies only if the BAND SPREAD dial pointer is set at 0.

BAND SPREAD KNOB - The BAND SPREAD knob permits you to accurately tune in stations on crowded bands by spreading them out so that they can be more easily separated. The BAND SPREAD knob can be used in two different ways. First, it may be left with the pointer at 5 while you partially tune in the desired station with the TUNING knob. Then, by "rocking" the BAND SPREAD knob back and forth (turn it a few degrees to the left and right through the desired station), you will be able to tune in the desired station with precision accuracy.

The second way to operate the BAND SPREAD knob is to use it to cover a group of stations. Set the BAND SPREAD knob so that the pointer reads 0 and then turn the TUNING knob to tune in the highest frequency station in the group. The other stations can be heard by slowly turning the BAND SPREAD knob from 0 to 100.

BEST SHORTWAVE RECEPTION TABLE

Band	Most Favorable Time	Most Favorable Distance
6-7 MC	Night - Winter	Day - 400 Miles - Night - Over 1500 Miles
9-10 MC	Day - Late Afternoon and Night - Winter	Over 500 Miles
11-12 MC	Evenings or Late Summer Afternoons	Day - Under 1500 Miles Night - Over 1500 Miles
15-18 MC	Early Mornings and Summer Evenings	Over 1500 Miles

SERVICE INSTRUCTIONS

GENERAL SPECIFICATIONS

Tubes 5 including 1 rectifier
 Speaker 5 inch PM
 Voice Coil Impedance 3.2 ohms
 Headphone Output Impedance . . . 15 ohms
 Antenna . . . Terminals for single wire or
 doublet antenna. (See Page 2.)
 Intermediate Frequency 455 KC
 Frequency Coverage . . . 540 KC - 32 MC
 Power Supply 105-125 volts DC or
 60 cycles AC
 Power Consumption 30 watts

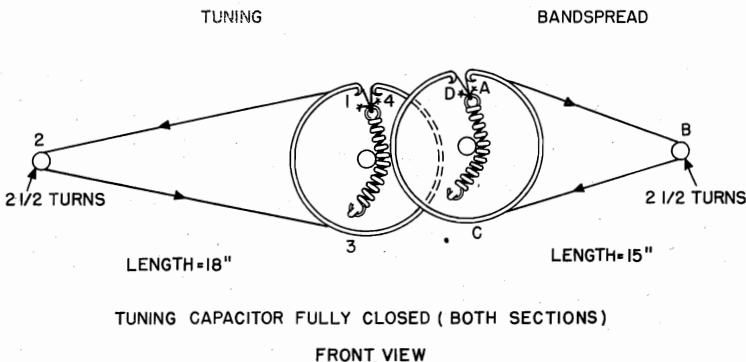

Fig. 2. Dial Cord Stringing Diagram

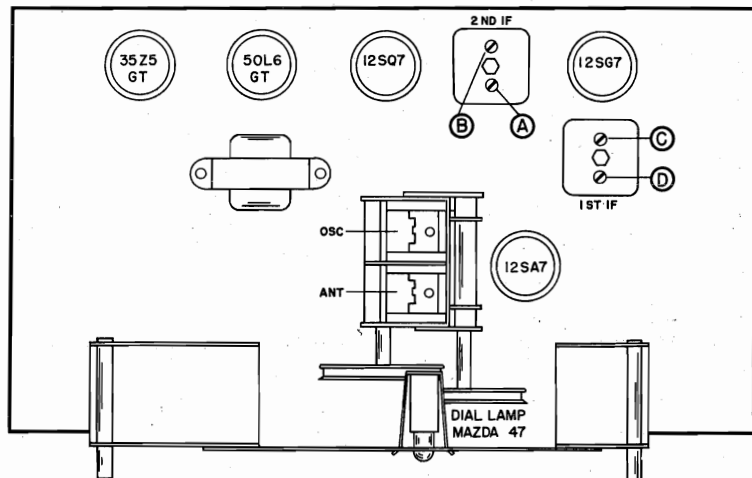

Fig. 3. Top View of Chassis Showing Location of Alignment Adjustments, Tubes and Dial Lamp

DIAL CORD STRINGING - Refer to Fig. 2 for the stringing diagram. Both sections of the tuning gang should be fully meshed. To restring the TUNING dial cord, tie one end of an 18 inch length of 30 lb. dial cord to the dial spring at 1 on the drive pulley. Follow the stringing sequence 1 through 4. At 4, stretch the spring and tie the cord securely to the spring. Cut off the excess cord and apply a drop of quick drying cement to the knot.

To restring the BAND SPREAD dial cord, cut a 15 inch length of dial cord and follow the procedure as explained above, starting at A and proceeding through D.

TUBE AND DIAL LAMP REPLACEMENT - Refer to Fig. 3 for the location of the tubes and dial lamp used in the receiver. To gain access to the tubes and lamp, remove the back cover from the cabinet. Before attempting to make any replacement, set the BAND SPREAD control fully clockwise and the TUNING control fully counterclockwise to prevent damage to the tuning gang. To replace a tube, insert the center guide pin into the center hole of the tube socket, rotate the tube until the key drops into position and then push down until the tube is held firmly in the socket. To make a dial lamp replacement, remove the dial lamp socket by compressing the side springs. Make replacement only with a type 47 pilot lamp.

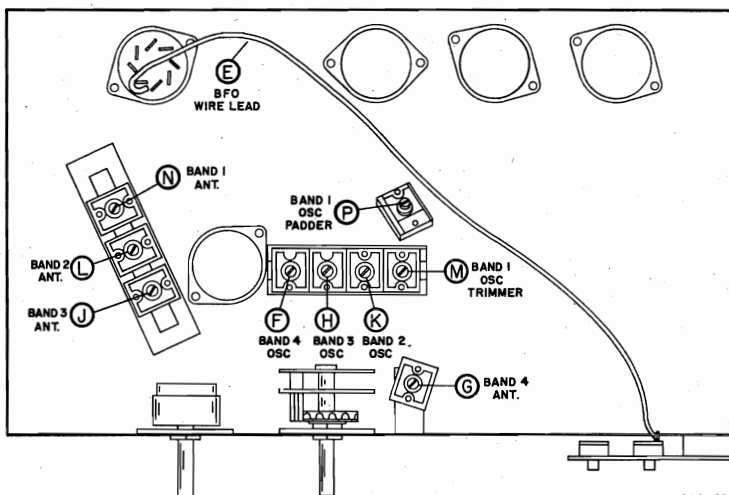

Fig. 4. Bottom View of Chassis Showing Location of Alignment Adjustments

ALIGNMENT INSTRUCTIONS

- Use an amplitude modulated generator covering 455 KC to 30 MC. Use a modulated output for every step except Step 2.
- Connect output meter across speaker voice coil.
- Use a non-metallic alignment tool.
- Set the AM/CW switch at AM, (except for BFO adjustment), SPEAKER/PHONES switch at SPEAKER, VOLUME control at maximum, RECEIVE/STANDBY switch at RECEIVE and the BAND SPREAD control at 0.
- See Figs. 3 and 4 for location of alignment adjustments.

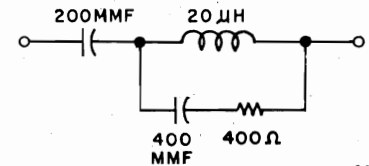

Fig. 5. RMA Dummy Antenna

92A1549

Step	Signal Generator Connections	Generator Frequency	Band Selector Setting	Receiver Dial Setting	Adjust
IF ALIGNMENT					
1	High side thru a .01 mfd. capacitor to stator plates of front section of TUNING gang. Low side to chassis.	455 KC	1	1.0 MC	A, B, C and D for maximum output. Keep reducing gen. output so that the reading on the output meter does not exceed 50 milliwatts
BFO ADJUSTMENT					
*2	Same as Step 1.	455 KC (No Mod.)	1	1.0 MC	Set the AM/CW switch at CW. (Reset the switch at AM when Step 2 is completed.) For correct BFO operation, vary the coupling between lead E and pins 4 and 8 of the 12SG7 tube for a maximum beat note. Pushing lead E toward pin 4 increases the strength of the beat.
RF ALIGNMENT					
3	High side thru RMA dummy antenna (Fig. 5) to terminal A1 on back of chassis. Low side to chassis. Connect jumper between A2 and G.	30 MC	4	30 MC	F and G for maximum output as in Step 1.
4	Same as Step 3.	14 MC	3	14 MC	H and J for maximum output as in Step 1.
5	Same as Step 3.	5 MC	2	5 MC	K and L for maximum output as in Step 1.
6	Same as Step 3.	1500 KC	1	1.5 MC	M and N for maximum output as in Step 1.
		500 KC	1	.6 MC	P for maximum output as in Step 1.

* Step 2 is usually unnecessary. Adjustment should be made ONLY if a weak beat note is obtained on strong CW signals indicating lack of coupling between wire lead E and pins 4 and 8 of the 12SG7.

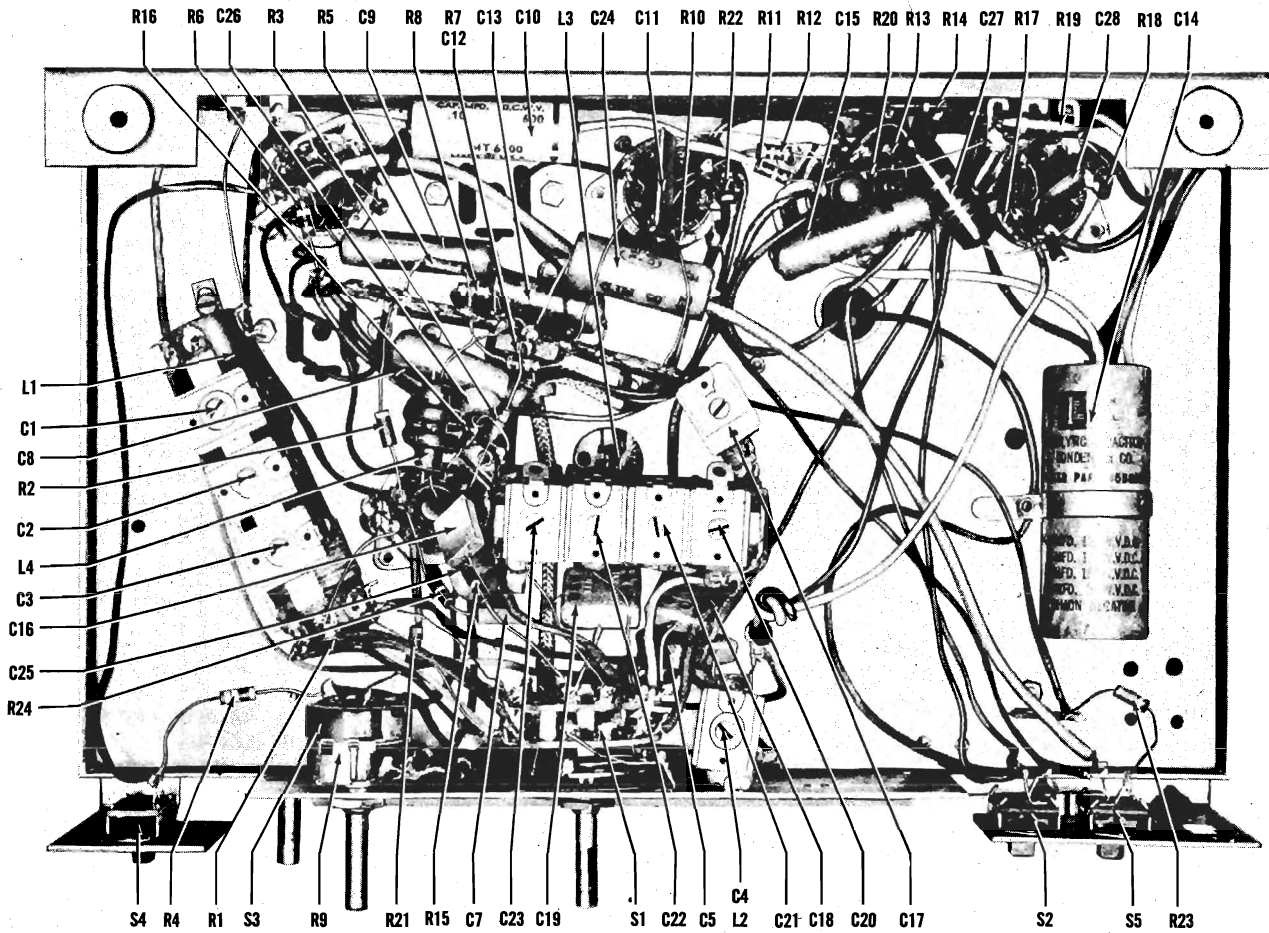
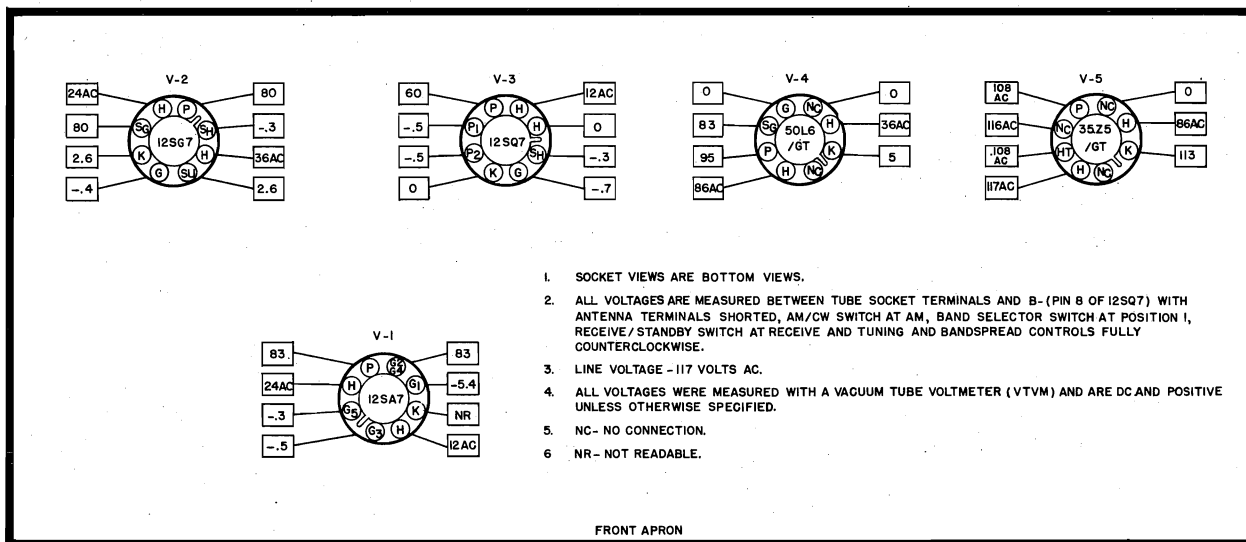

Fig. 6. Bottom View of Chassis Showing Component Location

92X1696 -A



1. SOCKET VIEWS ARE BOTTOM VIEWS.
2. ALL VOLTAGES ARE MEASURED BETWEEN TUBE SOCKET TERMINALS AND B- (PIN 8 OF 12SQ7) WITH ANTENNA TERMINALS SHORTED, AM/CW SWITCH AT AM, BAND SELECTOR SWITCH AT POSITION 1, RECEIVE/STANDBY SWITCH AT RECEIVE AND TUNING AND BANDSPREAD CONTROLS FULLY COUNTERCLOCKWISE.
3. LINE VOLTAGE - 117 VOLTS AC.
4. ALL VOLTAGES WERE MEASURED WITH A VACUUM TUBE VOLTMETER (VTVM) AND ARE DC AND POSITIVE UNLESS OTHERWISE SPECIFIED.
5. NC- NO CONNECTION.
6. NR- NOT READABLE.

FRONT APRON
BOTTOM VIEW OF CHASSIS

Fig. 7. Tube Socket Voltage Chart

92C1697 -A

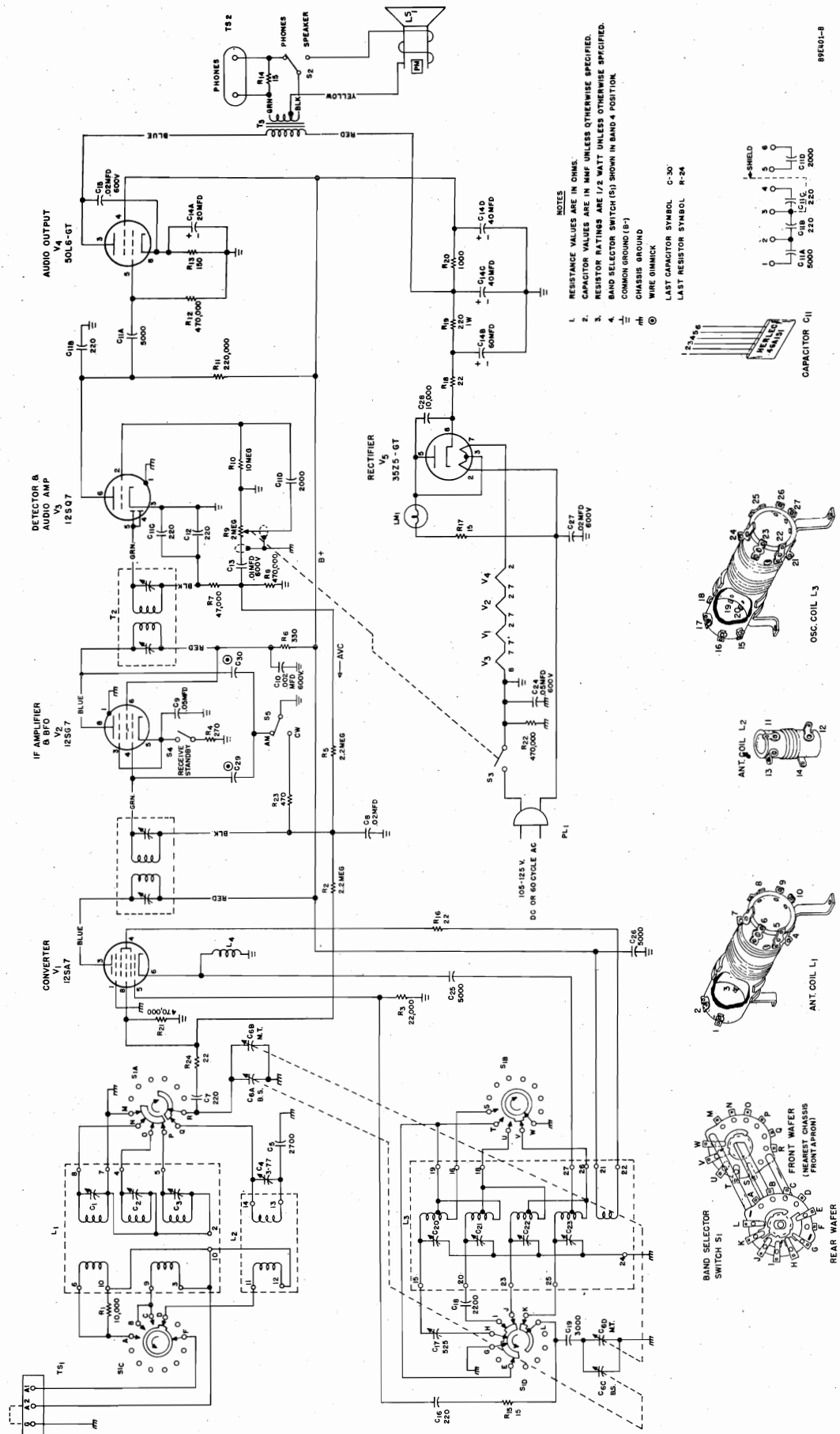

Fig. 8. Schematic Diagram

NOTE: VALUES & TOLERANCES SHOWN ARE NOMINAL AND VARIATIONS MAY BE FOUND. IT IS RECOMMENDED THAT THE VALUES OF ANY REPLACEMENT CORRESPOND TO THE NOMINAL VALUE OF THE PART BEING REPLACED.

SERVICE PARTS LIST

Schematic Symbol	Description	Hallicrafters Part Number	Schematic Symbol	Description	Hallicrafters Part Number
CAPACITORS					
C-1,2,3	Trimmer; part of antenna coil L-1	-----	S-1A,B,C&D	Bandswitch assembly (BAND SELECTOR)	60C393
C-4	Trimmer, 3-77 mmf.	44A039	S-2,5	Switch, slide; spdt (SPEAKER/ PHONES and AM/CW)	60A477
C-5	2700 mmf. 5%, 500V.; mica	47X30B272J	S-3	Switch, ON-OFF; part of VOLUME control R-9	-----
C-6A,B,C&D	Tuning capacitor, 2 section	48C162-1	S-4	Switch, slide; spst (RECEIVE/ STANDBY)	60A476
C-7,12,16	220 mmf. 10%, 500V.; mica	47X20B221K			
C-8,15	.02 mfd. 600V., tubular	46AY203J			
C-9	.05 mfd. 200V., tubular	46AU503J			
C-10	.002 mfd. 600V., tubular	46AZ202F			
C-11A,B,C &D	Capacitor, composite: 5000, .220, 220 and 2000 mmf., 500V.; ceramic	46A151			
C-13	.01 mfd. 600V., tubular	46AZ103J			
C-14A,B,C &D	60-40-40 mfd. 150V., 20 mfd. 25V.; electrolytic	45B091	TS-1	Socket, dial lamp; includes leads	86A011
C-17	Padder, 525 mmf.	44A349	TS-2	Socket, tube; octal	6A250
C-18	2200 mmf. 5%, 500V.; mica	47X30B222J		Terminal strip, antenna	88A671
C-19	3000 mmf. 5%, 500V.; mica	47X30B302J		Tip jacks, PHONE	88A071
C-20,21,22, 23	Trimmer; part of oscillator coil L-3	-----			
C-24	.05 mfd. 600V., tubular	46AY503J	V-1	12SA7: convertor	90X12SA7
C-25,26	5000 mmf. 450V., ceramic disc	47A168	V-2	12SG7: IF amplifier and BFO	90X12SG7
C-27	.02 mfd. 600V., molded tubular	46BR203L6	V-3	12SQ7 or 12SQ7GT/G: detector and audio amplifier	90X12SQ7 or 90X12SQ7GT/G
C-28	10,000 mmf. 450V., ceramic disc	47A217	V-4	50L6GT: audio output	90X50L6GT
			V-5	35Z5GT: rectifier	90X35Z5GT
			LM-1	Lamp, dial; type 47	39A004
RESISTORS					
R-1	10,000 ohms 1/2 watt, carbon	23X20X103M			
R-2,5	2.2 megohms 1/2 watt, carbon	23X20X225M			
R-3	22,000 ohms 1/2 watt, carbon	23X20X223M			
R-4	270 ohms 1/2 watt, carbon	23X20X271K			
R-6	330 ohms 1/2 watt, carbon	23X20X331M			
R-7	47,000 ohms 1/2 watt, carbon	23X20X473M			
R-8,12,21,22	470,000 ohms 1/2 watt, carbon	23X20X474M			
R-9	2 megohms; VOLUME control	25B896			
R-10	10 megohms 1/2 watt, carbon	23X20X106M			
R-11	220,000 ohms 1/2 watt, carbon	23X20X224M			
R-13	150 ohms 1/2 watt, carbon	23X20X151K			
R-14,15,17	15 ohms 1/2 watt, carbon	23X20X150M			
R-16,18,24	22 ohms 1/2 watt, carbon	23X20X220M			
R-19	220 ohms 1 watt, carbon	23X30X221M	PL-1	Line cord and plug	15A048
R-20	1000 ohms 1/2 watt, carbon	23X20X102M		Line cord lock; male section	87A078
R-23	470 ohms 1/2 watt, carbon	23X20X471K		Line cord lock; female section	76A397-1
				Mounting foot, cabinet	76A397-2
				Pointer, dial; BAND SPREAD	16A244
				Pointer, dial; TUNING	82A216
				Speaker, 5-inch PM	82A217
				Spring, dial cord	85C030
					75A012
COILS AND TRANSFORMERS					
L-1	Coil, antenna; bands 1, 2 and 3	51C821			
L-2	Coil, antenna; band 4	51B1015	LS-1		
L-3	Coil, oscillator; all bands	51C822			
L-4	Choke, RF; 540 microhenries	53A107			
T-1	Transformer, 1st IF	50C531			
T-2	Transformer, 2nd IF	50C532			
T-3	Transformer, audio output	55A127			
SWITCHES					
SOCKETS AND CONNECTORS					
TUBES AND DIAL LAMP					
MISCELLANEOUS PARTS					

HOW TO OPERATE RECORD PLAYER

If your record player has an automatic record changer, be sure to read the instructions packed with the changer before attempting to operate the unit.

If your record player is manually operated be sure that you select the proper speed for the record you are playing i.e., 33, 45, or 78 RPM. Also be certain that the cartridge in the phono pickup arm is in the proper position for the record you are playing. This is accomplished by rotating the small lever on the end of the arm in the direction of the arrow so that the proper speed appears on the lever.

When using 45 RPM records, it will be necessary to use a center hole adapter to make certain that the record is centered on the spindle. When using 45 RPM records on the record changer the center hole adapters should be of the type which locks into the center hole of the record.

INSTALLATION & OPERATION

LOCATION:

To place the unit in operation it should be resting firmly on a level surface. Do not place it near a heater or radiator since this may damage the cabinet.

POWER SUPPLY:

This phonograph is designed for operation on 105 - 125 volts 60 cycle alternating current (AC) only. Never connect to a supply having a frequency or voltage different than that specified. If in doubt check with your local electric power company.

OPERATION:

Connect supply cord to outlet and rotate "on-off tone" knob clockwise. Allow approximately one minute for unit to warm up. Place records on changer or turntable according to instructions above. Rotate "motor-volume" knob clockwise to turn on turntable motor. Adjust tone and volume as desired.

NORMAL CARE & MAINTENANCE

NEEDLES:

This unit is equipped with a semi-permanent needle which should last several years with normal care and use. If records seem excessively noisy and the needle is suspected of being defective it should be checked and replaced if necessary by a service man. Never allow needle to come in contact with turntable as this will ruin the needle.

TUBES:

Tubes should be checked about once a year and defective or weak tubes should be replaced. If unit fails to operate check power cord to see that it is making good contact in receptacle. Carefully re-read the instructions to be sure that you are operating the unit correctly. Have the tubes checked.

MODELS JP-100,
JP-300, Ch. AP3U

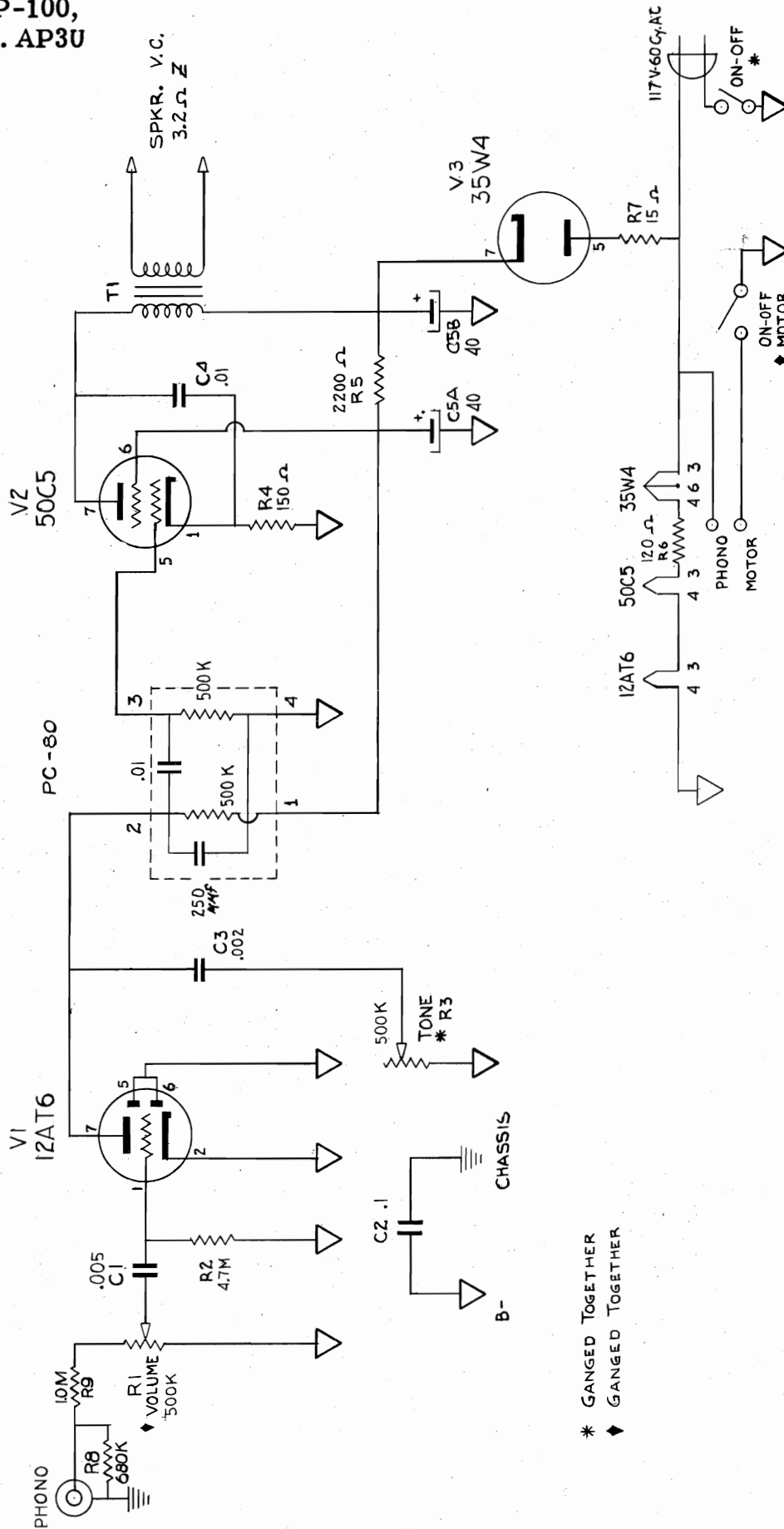

* GANGED TOGETHER
◆ GANGED TOGETHER

K = 1000 OHMS
M = 1,000,000 OHMS
ALL CAPACITORS IN MFD UNLESS
OTHERWISE NOTED.

VOLTAGE CHART

PIN	1	2	3	4	5	6	7
12AT6	-0.8	0	0	12AC	0	0	42
50C5	7.0	0	62AC	12AC	0	110	116
35W4	0	0	115AC	78AC	114AC	0	116

- NOTES: 1. MEASURED WITH VTVM FROM INDICATED PIN TO B- LINE.
 2. LINE VOLTAGE SET AT 115V 60~AC.
 3. VOLTAGE MAY VARY CONSIDERABLY DUE TO VARIATIONS IN LINE VOLTAGES AND COMPONENTS.

CAPACITORS

REF. NO.	PART NO.	DESCRIPTION
C ₁	CWZ06502M	.005 mfd. - 600V paper
C ₂	CWZ04104M	.1 mfd - 400V paper
C ₃	CWZ06202M	.002 mfd - 600V paper
C ₄	CWZ06103M	.01 mfd - 600V paper
C ₅ A, B	CED4415	40-40 mfd - 150V electrolytic

RESISTORS

REF. NO.	PART NO.	DESCRIPTION
R ₁	RVC301S	500K audio volume control with switch
R ₂	RCC475M	4.7M ±20% - 1/2 Watt
R ₃	RVC301S	500K tone control
R ₄	RCC151M	150 ohms ±20% - 1/2 Watt
R ₅	RCF222M	2200 ohms ±20% - 1 Watt
R ₆	RLJ121K	120 ohms ±10% - 5 Watts wire wound
R ₇	RCC150M	15 ohms ±20% - 1/2 Watt
R ₈	RCC684M	680K ±20% - 1/2 Watt
R ₉	RCC105M	1.0M ±20% - 1/2 Watt

MISCELLANEOUS

PC-80	A-1376-6F	Couplate
TI	A-1658-13	Audio output transformer 2500 ohms to 3.2 ohms
.....	C-2502-14	Crystal Pickup
.....	B-4602-15	5" PM Speaker
.....	C-2501-14	3 Speed phono motor

HOW TO ORDER REPAIR PARTS

Always give the part No. (No. printed on the part if different from that shown on this list), and the name of the part. When No. is not available, give complete description of part. Be sure to always give the Model No. & Chassis No. The Model No. will be found on a printed label which will be found at the back of the cabinet. Chassis number is stamped on the amplifier chassis inside the unit.

MODELS JP-200,
JP-400, Ch. AP5U

HOW TO OPERATE THE RADIO:

This radio is equipped with three controls, the right hand control is the combined off-on switch and volume control. The left hand control is the phono-radio switch, the center control is used for tuning the desired station. To place the set in operation, rotate on-off volume control knob to right and allow 30 seconds for set to warm up. Rotate tuning control to desired station. Adjust volume control to desired volume. To use phonograph follow above steps, except turn phono-radio switch, to phono position. Place records on changer in sequence desired, push reject button, and allow changer to cycle.

ALIGNMENT PROCEDURE

Feed a 455 K.C. modulated signal from grid (pin No. 7 12BE6 through a .01 M.F.D. condenser) and B-. Connect an output meter across the voice coil. Tune slugs on first and second I.F. transformers for maximum indication on meter. Set signal generator to 1600 KC modulated signal and couple loosely to loop antenna. Set dial to 1600 K.C. and tune oscillator trimmer for maximum indication on meter.

Set signal generator and dial to 1400 K.C. and tune R.F. trimmer, for maximum indication on meter. Check tracking at 600 K.C., knife gang if necessary. Repeat these adjustments until the receiver tracks correctly.

HOW TO ORDER REPAIR PARTS

Always give the part No. (No. printed on the part if different from that shown on this list), and the name of the part. When No. is not available, give complete description of part. Be sure to always give the Model No. and Catalog No. The Model No. will be found on a printed label which will be found at the back of the cabinet.

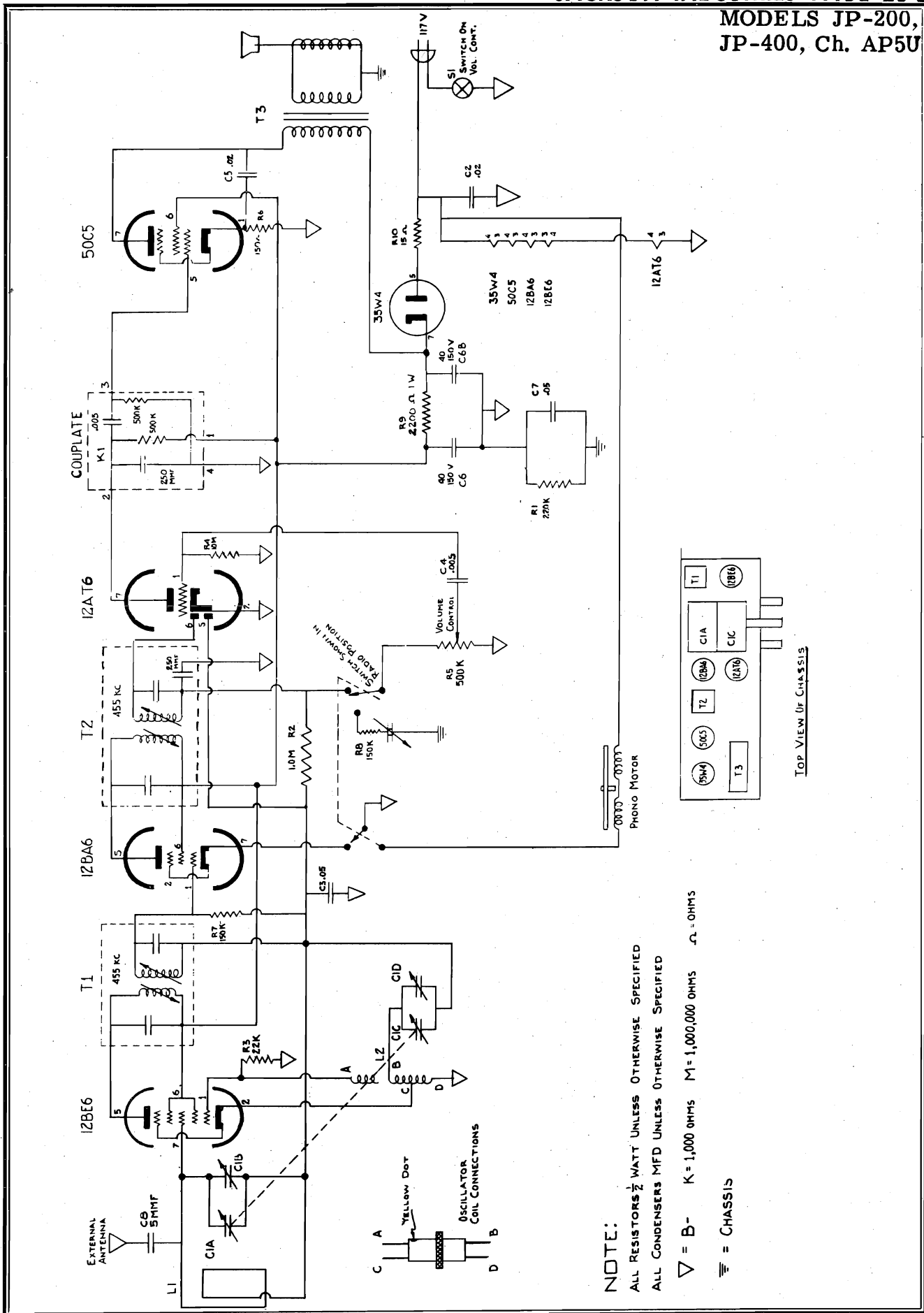

NOTE:
 ALL RESISTORS $\frac{1}{2}$ WATT UNLESS OTHERWISE SPECIFIED
 ALL CONDENSERS MFD UNLESS OTHERWISE SPECIFIED
 ∇ = B- K = 1,000 OHMS M = 1,000,000 OHMS \cdot = OHMS
 \equiv = CHASSIS

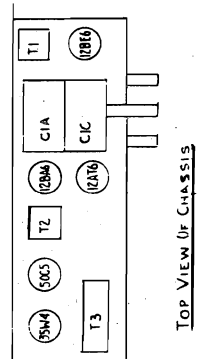

MODELS JP-200,
JP-400, Ch. AP3U

VOLTAGE CHART

PIN	#1	#2	#3	#4	#5	#6	#7
12BE6	-7.5	0	12AC	23AC	90	90	0
12BA6	-0.8	0	23AC	35AC	90	90	0
12AT6	-0.8	0	0	12AC	-0.8	-0.5	45
50C5	6	0	35AC	83AC	0	90	120
35W4	0	0	83AC	117AC	115AC	0	130

NOTES:

1. Measured with VTVM from indicated pin to B - line.
2. Phono-radio switch in radio position.
3. Line voltage set at 117V 60~AC.
4. Voltage s may vary considerably due to variations in line voltage and components.

CAPACITORS

REF. NO.	PART NO.	DESCRIPTION
C ₁	A-1200-6	TUNING CAPACITOR
C ₂	CWZ 04203 M	.02 Mfd 400 volts
C ₃	CWZ 04503 M	.05 Mfd 400 volts
C ₄	CWZ 06502 M	.005 Mfd 600 volts
C ₅	CWZ 04203 M	.02 Mfd 400 volts
C ₆	CED - 4415	DUAL 40 Mfd 150 volt electrolytic capacitor
C ₇	CWR - 04503 M	.05 Mfd resonant
C ₈	CCC, 05050 M	5 Mmf ceramic or mica

RESISTORS

REF. NO.	PART NO.	DESCRIPTION
R ₁	RCC 224 M	220,000 ohms ± 20% ½ watt Resistor
R ₂	RCC 105 M	1.0 megohms ± 20% ½ watt Resistor
R ₃	RCC 223 M	22,000 ohms ± 20% ½ watt Resistor
R ₄	RCC 106 M	10 megohms ± 20% ½ watt Resistor
R ₅	RVC - 301 S	500,000 ohms volume control audio taper with switch
R ₆	RCC 151 M	150 ohms ± 20% ½ watt
R ₇	RCC 154 M	150,000 ohms ± 20% ½ watt
R ₈	RCC 154 M	150,000 ohms ± 20% ½ watt
R ₉	RCF 222 M	2,200 ohms ± 20% 1 watt
R ₁₀	RCC 150 M	15 ohms ± 20% ½ watt

COILS AND TRANSFORMERS

REF. NO.	PART NO.	DESCRIPTION
L ₁	A - 1493 - 10	Loop Antenna
L ₂	A - 1492 - 10	Oscillator Coil
T ₁	A - 1490 - 10	Input IF Transformer
T ₂	A - 1491 - 10	Output IF Transformer
T ₃	A - 1656 - 13	Audio Output Transformer 2500Ω to 3.2

MISCELLANEOUS

C - 2500 - 14	Record changer - VM
A - 1059 - 4	Control knob
A - 1060 - 4	Pointer knob
100-84	Record Changer - Webster

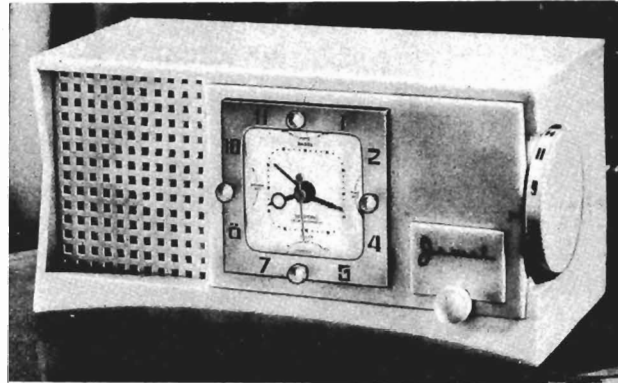

• CHASSIS SPECIFICATIONS •

- Tuning Range: 540 Kc to 1650 KC
- 105 to 125 volts, 60 cycles A.C. only
50 cycles available on special order.
- Cabinet Size: Width, 11-1/16"
Height, 5 1/4"
Depth, 5 3/4"
- Tube complement:
 - 1—12BE6 Converter
 - 1—12BA6 I.F. Amplifier
 - 1—12AT6 Detector, first audio and A.V.C.
 - 1—50C5 Beam Power Output
 - 1—35W4 Rectifier
- Power Consumption: 30 watts

Alignment Procedure

Output meter across voice coil (3.2 ohm)
Volume control at maximum for all adjustments.
Align for maximum output. Reduce input as needed to keep output near 1.28 volts (0.5 watt).

SIGNAL GENERATOR					
Fre- quency	Coupling Capacitor	Connection to Receiver	Ground Connection	Tuner Setting	Adjust trimmers to maximum out- put (in order shown)
455kc	0.1 mf	12BE6 grid	B-	Rotor fully open (plates out of mesh)	Primary & second- ary slugs of I. F. transformer
1650kc	0.1 mf	12BE6 grid	B-	Rotor fully open (plates out of mesh)	Osc. trimmer
1500kc		Radiating loop		1500kc	Antenna trimmer

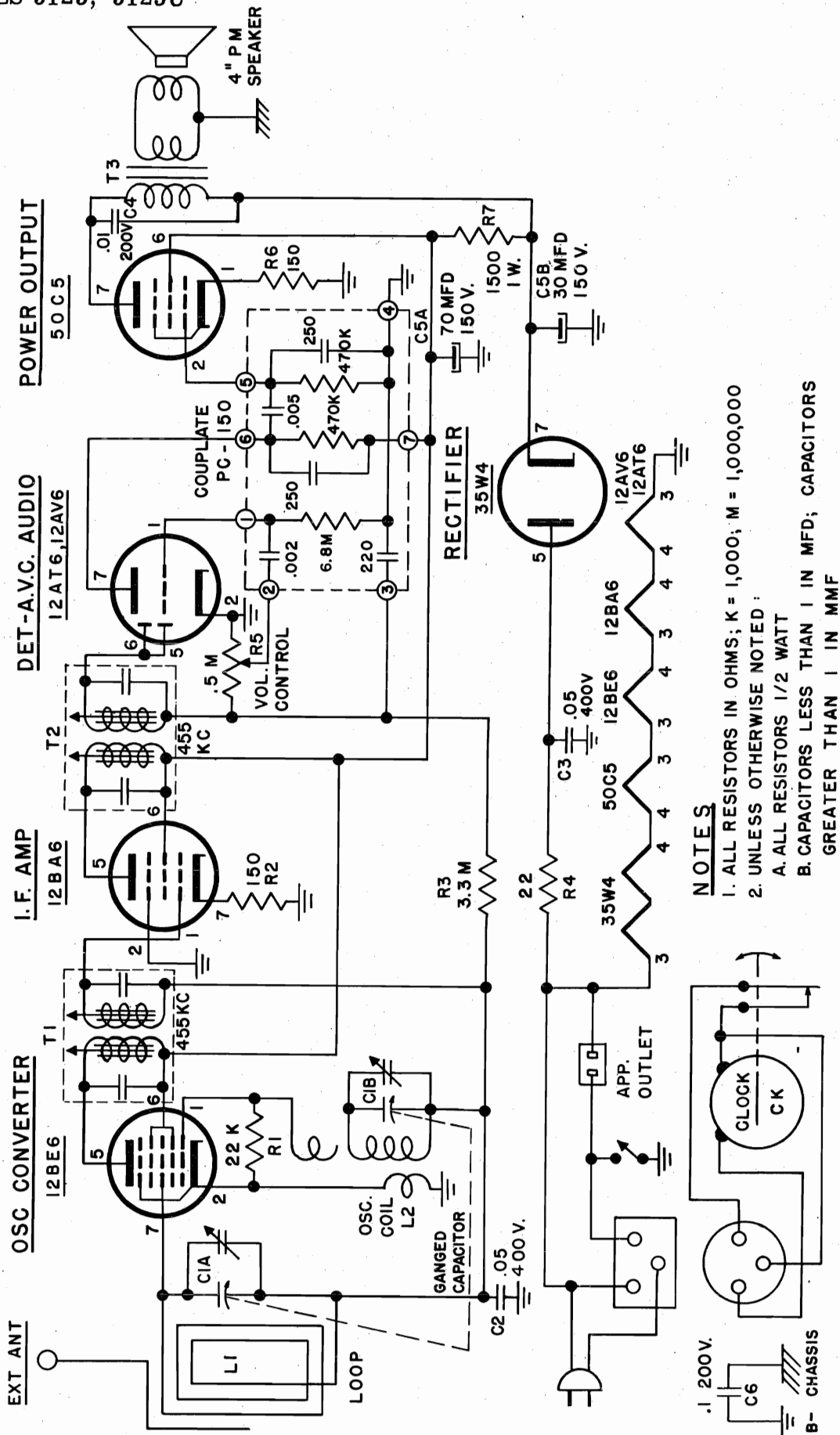

NOTES

1. ALL RESISTORS IN OHMS; K = 1,000; M = 1,000,000
2. UNLESS OTHERWISE NOTED:
 - A. ALL RESISTORS 1/2 WATT
 - B. CAPACITORS LESS THAN 1 IN MFD; CAPACITORS GREATER THAN 1 IN MMF

Part No.	Description	Coils and Transformers	
Resistors		60-31	Oscillator coil
20-223-31	22KΩ 1/2w 20%	61-11	I. F. transformer
20-335-31	3.3MΩ 1/2w 20%	Miscellaneous	
20-151-31	150Ω 1/2w 20%	80-36	Speaker 4"
20-152-41	1500Ω 1w 20%	120-94	Cabinet
20-220-31	22Ω 1/2w 20%	122-65	Selector knob
50-42	Volume cont. . 5MΩ SPST	122-69	Volume control knob
Capacitors		125-58	Back with loop
30-48	Variable	Tubes	
31-41	70/30mf 150V elect.	12BE6	
32-5	.05mf 400V paper tub.	12BA6	
32-30	.1mf 200V paper tub.	12AV6 or 12AT6	
32-29	.01mf 200V paper tub.	50C5	
36-5	Couplate	35W4	

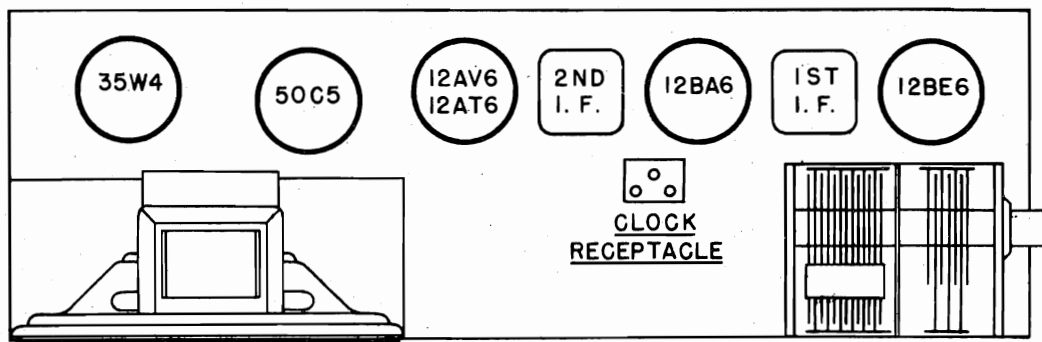

MODELS 5205,
5205B, 5205E,
5205G, 5205I,
5205R, 5205W

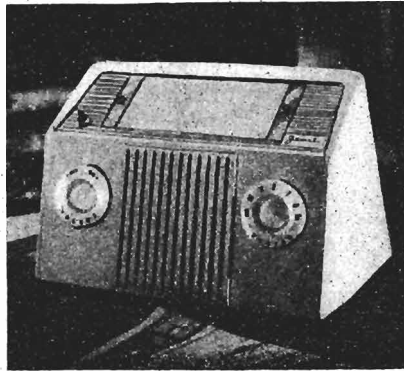

• CHASSIS SPECIFICATIONS •

- ★ Superheterodyne circuit
- ★ A.C.-D.C. Operation
- ★ 105-125 Volts A.C. and same D.C.
- ★ Power Consumption: 30 Watts
- ★ 'Alnico' V P.M. Wonder Speaker . . . full tonal range
- ★ Tuning range: 540 K.C.—1650 K.C.
- ★ TUBE COMPLEMENT:
1—12BE6, 1—12BR6, 1—12AT6,
1—50C5, 1—35W4
- ★ Built-in "DURALOOP" antenna
- ★ Weight of set: 4 lbs.
- ★ Weight of carton: add 1½ lbs.
- ★ Size of cabinet: Width, 10¼"; Depth, 6⅞"
Height, 5⅝"
- ★ Model 5205E (Ebony)
Model 5205W (Walnut)
Model 5205I (Ivory)
Model 5205B (Boudoir Blue)
Model 5205R (Dusty Rose)
Model 5205G (Grey)

Alignment Procedure

Output meter across voice coil (3.2 ohm)
Volume control at maximum for all adjustments.
Align for maximum output. Reduce input as needed to keep output near 1.28 volts (0.5 watt).

SIGNAL GENERATOR					
Fre- quency	Coupling Capacitor	Connection to Receiver	Ground Connection	Tuner Setting	Adjust trimmers to maximum out- put (in order shown)
455kc	0.1 mf	12BE6 grid	B-	Rotor fully open (plates out of mesh)	Primary & second- ary slugs of I. F. transformer
1650kc	0.1 mf	12BE6 grid	B-	Rotor fully open (plates out of mesh)	Osc. trimmer
1500kc		Radiating loop		1500kc	Antenna trimmer

MODELS 5205, 5205B,
5205E, 5205G, 5205I,
5205R, 5205W

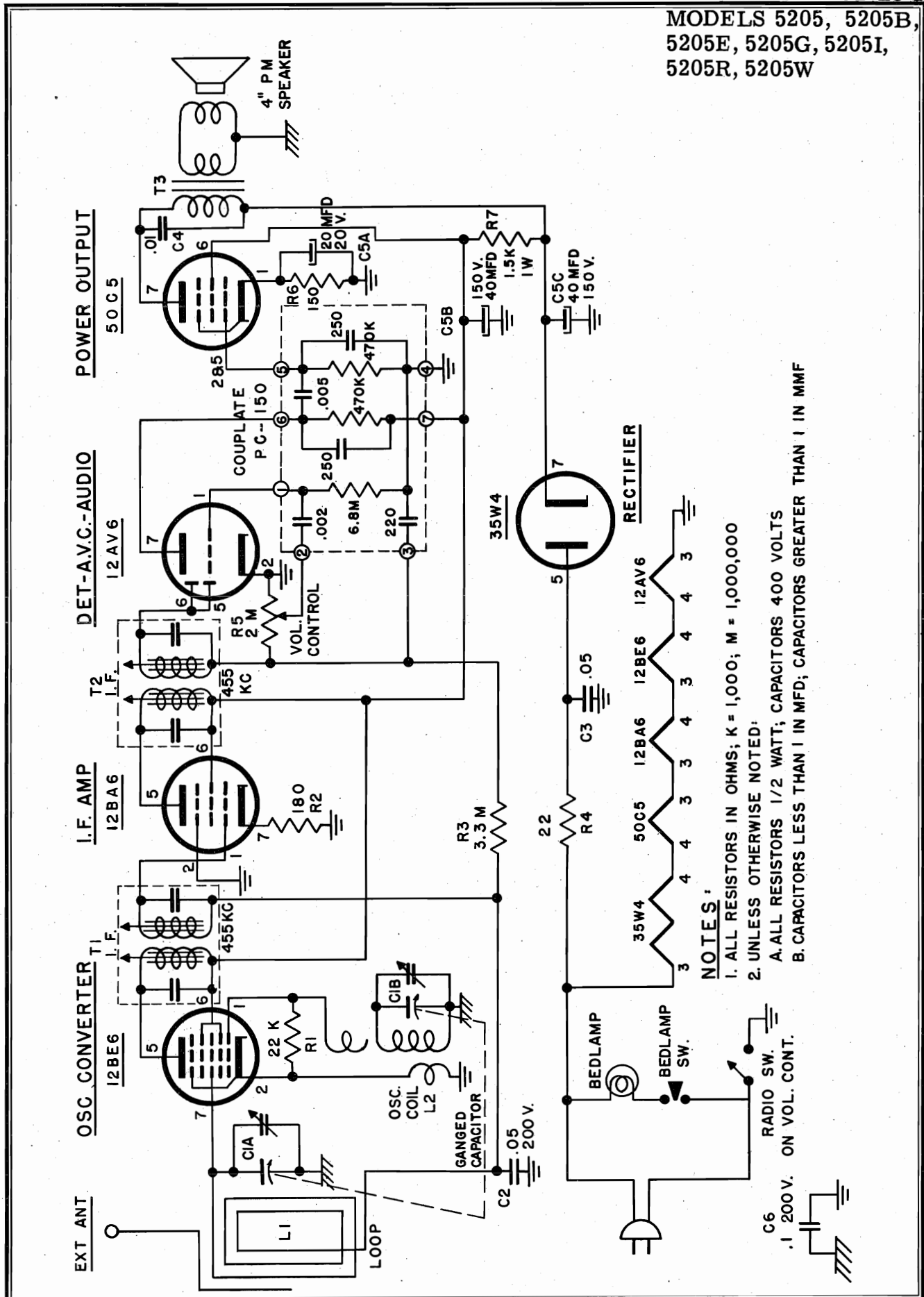

MODELS 5205, B,
E, G, I, R, W

Part No.	Description		
Resistors		Coils and Transformers	
20-220-31	22Ω 1/2w 20%	60-34	Oscillator coil
20-152-41	1500Ω 1w 20%	61-11	I. F. Transformer
20-151-31	150Ω 1/2w 20%		
20-181-31	180Ω 1/2w 20%		
20-223-31	22KΩ 1/2w 20%		
20-335-31	3.3MΩ 1/2w 20%		
50-37	Volume cont. -SPST Switch		
Capacitors		Miscellaneous	
30-41	420mmf-108mmf Variable	80-37	Speaker 4"
31-42	30mf 20V, 40mf-40mf 150V electrolytic	120-64H	Cabinet
32-55	.05mf 400V	122-51	Selector knob
32-29	001mf 200V, paper tubular	122-52	Volume knob
32-57	.1mf 400V		
32-4	.05mf 200V		
36-5	Couplate		
		Tubes	
		12BE6	
		12BA6	
		12AU6	
		50C5	
		35W4	

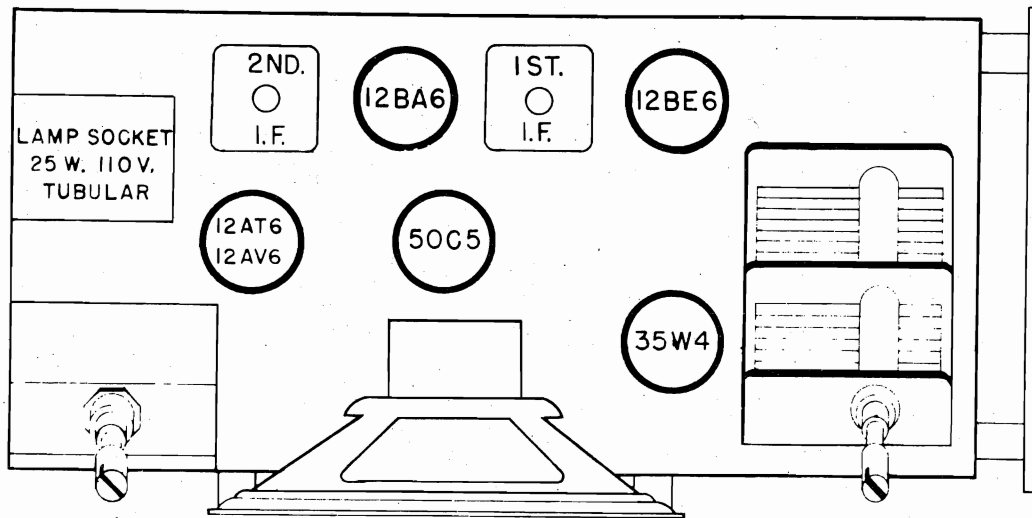

TUBE LAYOUT

SPECIFICATIONS

"WAKEMASTER" — MODEL 5250

1. Superheterodyne circuit
2. Built-in loop antenna
3. 5 tubes
4. 60 cycle operation—50 cycle movements available on special order
5. Self-starting clock — sweep second movement — upon pre-setting, automatically turns on radio
6. Molded all plastic cabinet in pure plastic colors: Ivory, Walnut, Ebony (also decorator colors)

Electrical Specifications

105-125 Volts AC 60 Cycles
 Maximum power output 1.4 watts
 Full A.V.C. for optimum quieting
 Hi-"Q" low loss antenna circuit for optimum sensitivity
 Full broadcast frequency coverage, 540 Kc to 1650 Kc
 Alnico V P.M. speaker—full tonal range

Tube Line-up and Functions

12BE6 Converter
 12AU6 I.F. Amplifier
 12AT6 (12AU6) Detector and first audio, A.V.C.
 50C5 Output
 35W4 Rectifier

Alignment Procedure

Output meter across voice coil (3.2 ohm)
 Volume control at maximum for all adjustments.
 Align for maximum output. Reduce input as needed to keep output near 1.28 volts (0.5 watt).

SIGNAL GENERATOR					
Fre- quency	Coupling Capacitor	Connection to Receiver	Ground Connection	Tuner Setting	Adjust trimmers to maximum out- put (in order shown)
455kc	0.1 mf	12BE6 grid	B-	Rotor fully open (plates out of mesh)	Primary & second- ary slugs of I. F. transformer
1650kc	0.1 mf	12BE6 grid	B-	Rotor fully open (plates out of mesh)	Osc. trimmer
1500kc		Radiating loop		1500kc	Antenna trimmer

MODELS 5250,
5250AP, 5250U,
Wakemaster

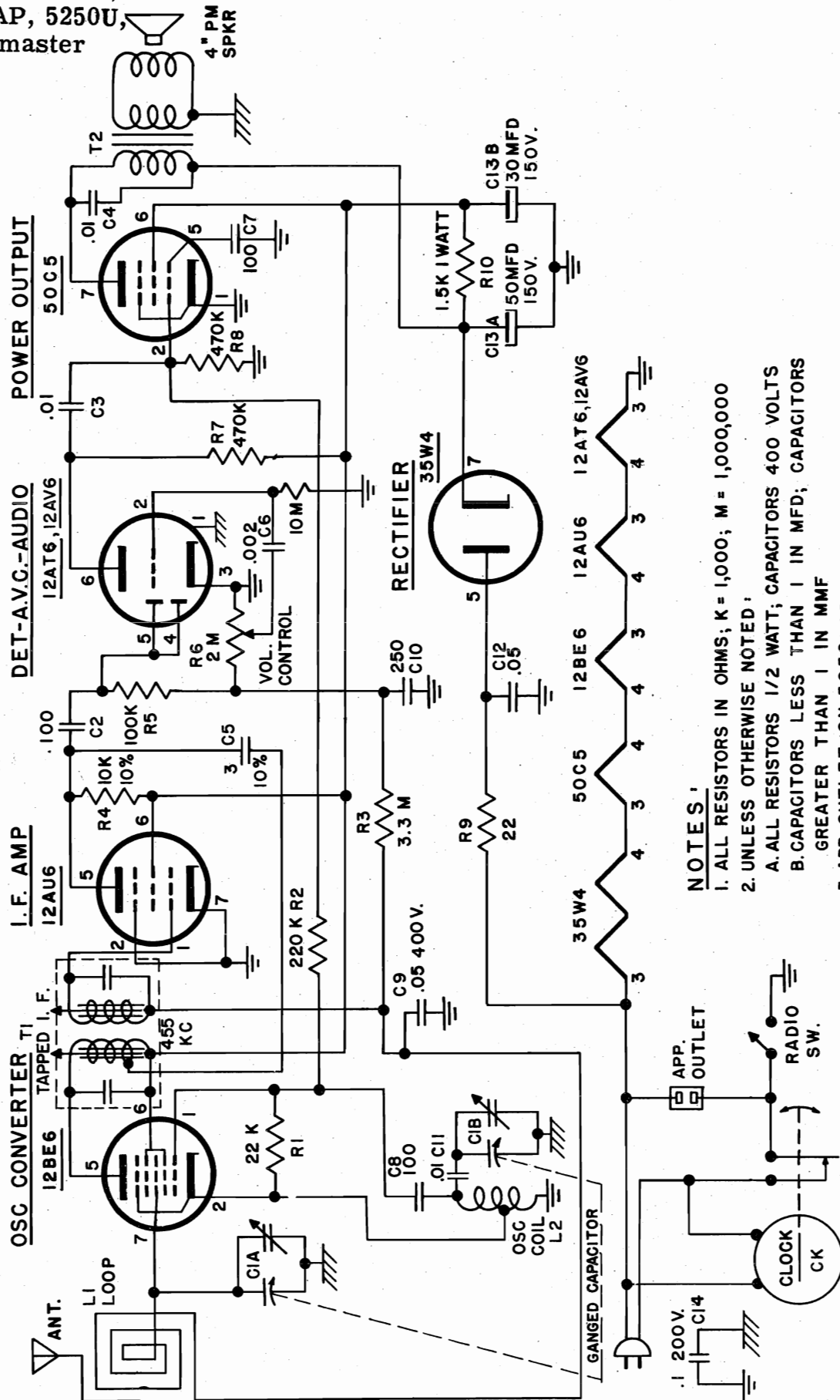

NOTES:

1. ALL RESISTORS IN OHMS; K = 1,000; M = 1,000,000
2. UNLESS OTHERWISE NOTED:
 - A. ALL RESISTORS 1/2 WATT; CAPACITORS 400 VOLTS
 - B. CAPACITORS LESS THAN 1 IN MFD; CAPACITORS GREATER THAN 1 IN MMF
3. APP. OUTLET ON 5250UAP

MODELS 5250, 5250AP,
5250U, Wakemaster

Part No.	Description		
Resistors		35-32	3mmf 500V ceramic 10%
20-103-32	10K Ω 1/2w 10%	35-34	.002-500V disc ceramic
20-104-31	100K Ω 1/2w 20%	35-29	.01mf disc ceramic
20-106-31	10M Ω 1/2w 20%	Coils and Transformers	
20-220-31	22 Ω 1/2w 20%	60-27	Oscillator coil
20-223-31	22K Ω 1/2w 20%	6126	I. F. Transformer
20-224-31	220K Ω 1/2w 20%	Miscellaneous	
20-335-31	3.3M Ω 1/2w 20%	65-11	Switch SPST
20-474-31	470K Ω 1/2w 20%	80-30B	Speaker 4"
20-152-41	1.5K Ω 1w 20%	120-62G	Cabinet
50-34D	Volume cont. 2M Ω	122-49	Selector knob
Capacitors		122-50	Volume knob
30-38A	Variable	125-64	Back with loop
31-39	50-30mf 150V elect.	125-66	Back with loop
32-4	005mf 200V paper tub.	Tubes	
32-5	.05mf 400V paper tub.	12BE6	
32-30	.1mf 200V, paper tub.	12BF6	
35-1	250mmf 500V mica	12AU6	
35-30	100mmf 500V ceramicon	50C5	
35-30	100mmf 500V ceramicon	35W4	
35-29	.01mf disc ceramic	12SQ7	

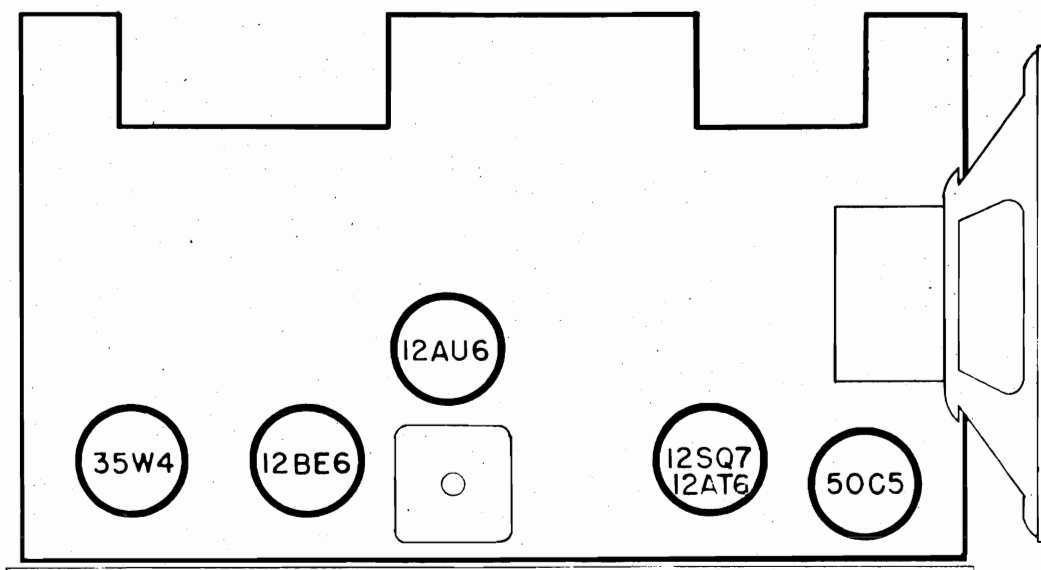

TUBE LAYOUT

SPECIFICATIONS

JEWEL — MODEL 5200

1. Superheterodyne circuit
2. Full sweep dial
3. Built-in loop antenna
4. 5 tubes
5. A.C. - D.C. operation
6. Molded all plastic cabinet in pure plastic colors: Ivory, Walnut, Ebony and Chinese Red

Electrical Specifications

110-125 Volts AC 50-60 cycles
 110-125 Volts DC
 Maximum power output 1.4 watts
 Full A.V.C. for optimum quieting
 Bandwidth—9.5 Kc at 2 times down for optimum selectivity
 Hi-"Q" low loss antenna circuit for optimum sensitivity
 Full broadcast frequency coverage, 540 Kc to 1650 Kc
 Alnico No. 5 P.M. Speaker—full tonal range

Tube Line-up and Functions

12BE6 Converter
 12AU6 I.F. Amplifier
 12AT6 or 12AV6 Detector and first audio, A.V.C.
 50C5 Output
 35W4 Rectifier

Alignment Procedure

Output meter across voice coil (3.2 ohm)
 Volume control at maximum for all adjustments.
 Align for maximum output. Reduce input as needed to keep output near 1.28 volts (0.5 watt).

SIGNAL GENERATOR					
Fre- quency	Coupling Capacitor	Connection to Receiver	Ground Connection	Tuner Setting	Adjust trimmers to maximum out- put (in order shown)
455kc	0.1 mf	12BE6 grid	B-	Rotor fully open (plates out of mesh)	Primary & second- ary slugs of I. F. transformer
1650kc	0.1 mf	12BE6 grid	B-	Rotor fully open (plates out of mesh)	Osc. trimmer
1500kc		Radiating loop		1500kc	Antenna trimmer

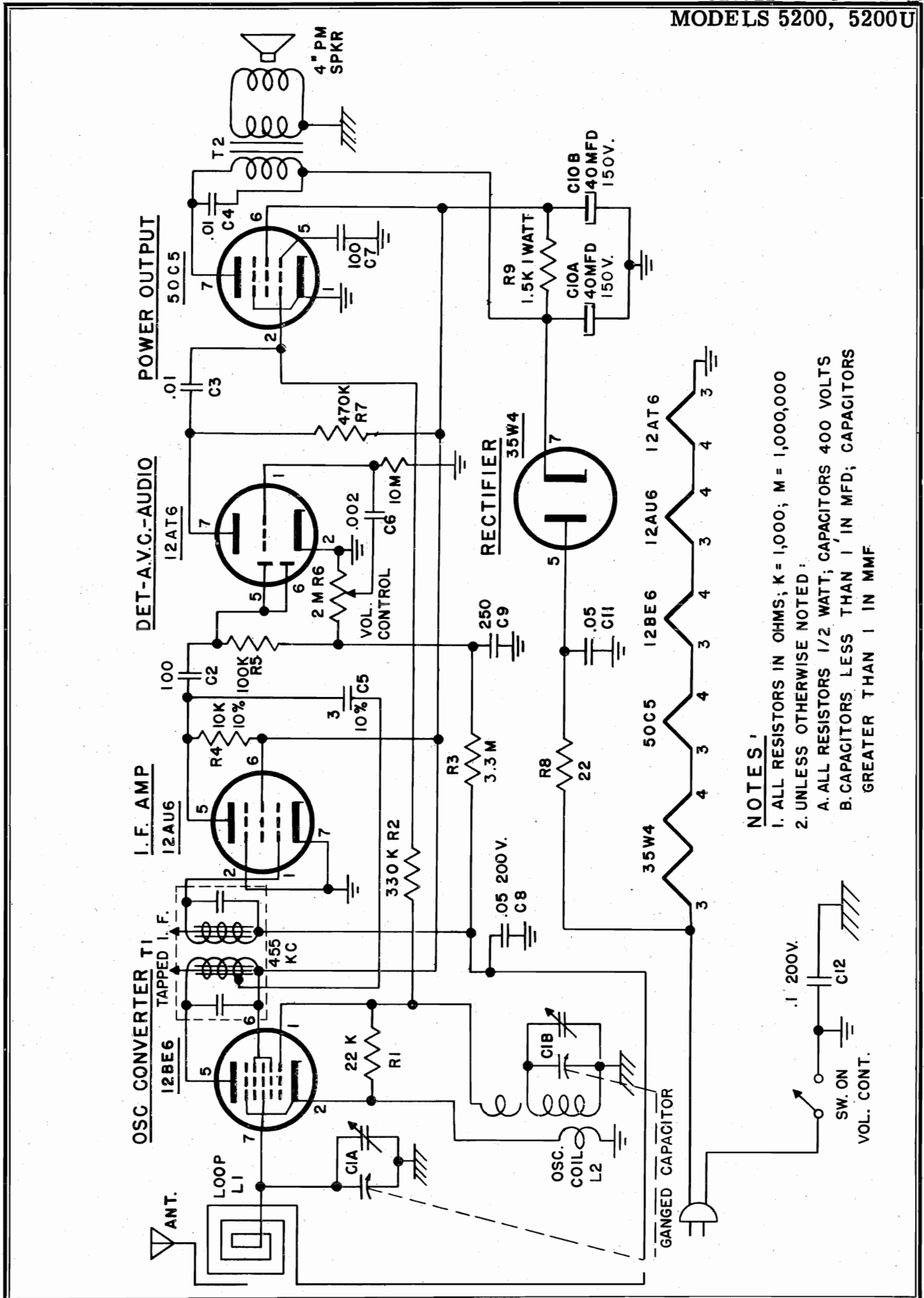

- NOTES:**
1. ALL RESISTORS IN OHMS; K = 1,000; M = 1,000,000
 2. UNLESS OTHERWISE NOTED:
 - A. ALL RESISTORS 1/2 WATT; CAPACITORS 400 VOLTS
 - B. CAPACITORS LESS THAN 1' IN MFD; CAPACITORS GREATER THAN 1' IN MMF

MODELS 5200, 5200U

Part No.	Description		
Resistors		Coils and Transformers	
20-223-31	22KΩ 1/2w 20%	60-32	Oscillator coil
20-334-31	330KΩ 1/2w 20%	61-26	I. F. transformer
20-335-31	3.3MΩ 1/2w 20%	Miscellaneous	
20-474-31	470KΩ 1/2w 20%	80-17B	Speaker 4"
50-11B	Volume cont. 2MΩ SPST Switch	120-70	Cabinet
Capacitors		122-57	Knob, selector
3146	40/40/150V elect.	122-15	Knob, volume
32-4	.05mf 200V paper tub.	125-62	Back with loop
32-5	.05mf 400V paper tub.	Tubes	
32-17	.002mf 200V paper tub.	12	
32-30	.1mf 200V paper tub.	12BE6	
35-1	250mmf 500V mica	12AV6	
35-29	.01mf disc ceramic	12AU6	
35-29	.01mf disc ceramic	50C5	
35-30	100mmf 500V ceramicon	35W4	
35-33	4mmf 500V 10% ceramicon		

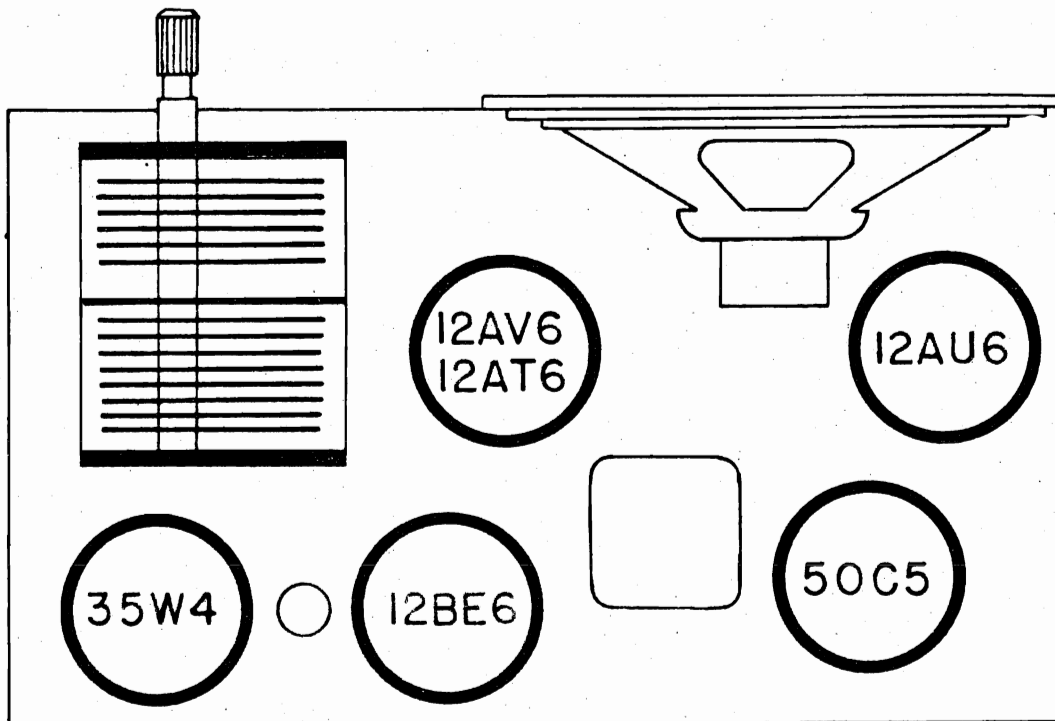

SPECIFICATIONS

Power supply.....	117 volts 50/60 cycles AC
Power consumption.....	95 watts
Power output.....	10 watts
Intermediate frequency.....	455 kc./10.7 mc.

Tuning frequency range:

Broadcast Band.....	540-1620 kc.
FM Band.....	88-108 mc.

Tubes:

R-F Amplifier.....	6BA6
Converter.....	6BE6
1st I-F Amplifier (AM-FM).....	6BA6
2nd I-F (FM), Detector and AVC (AM).....	6BA6
Limiter.....	6AU6
Discriminator.....	6AL5
First Audio.....	6AV6
Inverter.....	6SN7GT
Power output (push-pull stage).....	(2) 6V6GT
Rectifier.....	5Y3GT
Dial Lamps.....	Mazda No. 44

Speaker:

Field coil resistance.....	500 ohms
Voice coil impedance (400 cycles).....	3.0 ohms
Output transformer.....	8,000/3 ohms

ALIGNMENT PROCEDURE

Alignment of this receiver requires the use of an accurately calibrated r-f signal generator, range 455 kc. to 107 mc., an output meter, and a vacuum tube voltmeter of greater than 10 megohm input impedance. All trimmer condensers can be identified by stampings on the chassis and gang condenser cover and are shown on the chassis layout diagram.

The pointer on the radio dial should line up with the first vertical mark on the low frequency end of the dial glass. If the pointer does not line up, loosen the pointer on the dial string and move it to correct position. Re-tighten and re-cement the pointer to the string. Be sure the gang is fully meshed for this pointer alignment. Align AM first.

AM ALIGNMENT**I-F ALIGNMENT**

1. Set treble control to SHARP TUNE position. Set volume and bass controls to maximum, the Band Switch to Broadcast position, and dial pointer to 1000 kc.
2. Tune the signal generator to EXACTLY 455 kc.
3. Connect output of modulated signal generator to the signal grid of the 6BE6 (pin 7) through a .01 mfd. capacitor and signal generator ground to radio chassis.

4. AM and FM i-f transformers on this model are separate and can be identified on the chassis layout diagram Figure 3.

5. Connect output meter across voice coil of speaker and adjust the i-f transformers for peak output as indicated on the output meter.

ALTERNATE VISUAL ALIGNMENT OF I-F STAGES

1. Connect 455 kc. sweep generator having approximately 20 kc. sweep to signal grid of 6BE6 (pin 7) through a .01 mfd. capacitor. Connect an oscilloscope through a 1 megohm isolating resistor across the 220,000 ohm diode load resistor. Align for best possible peak in sharp tune position and symmetry in full range position.

R-F ALIGNMENT

1. Remove the signal generator lead from the 6BE6 grid and connect it across H and L on terminal strip on the rear of the chassis. The high side of the signal generator should be connected to H and the signal generator ground to L.

2. Check the tuning dial pointer adjustment. When the plates of the tuning condenser are completely meshed, the dial pointer must be in line with the last calibration mark at the low frequency end of the dial. If it is not, slide the pointer on its string to the correct position. Be sure to crimp the lugs (on the rear of the pointer) tightly around the string to hold the pointer in adjustment.

3. Set the signal generator and the radio receiver to 1400 kc., adjust the 1400 kc. oscillator trimmer and the 1400 kc. r-f trimmer for maximum output.

4. Set the signal generator and radio receiver to 600 kc. Adjust the oscillator and r-f coil slugs for maximum output. If considerable adjustment was necessary re-check the 1400 kc. trimmer settings.

5. Replace chassis in cabinet and connect loop antenna leads to proper terminals on the rear of the chassis.

6. Form three turns of wire into a loop, connect this loop to the signal generator and loosely couple it to the receiver loop antenna.

7. With the signal generator and dial at 1400 kc., adjust the loop antenna trimmer for maximum output.

10 KC FILTER ADJUSTMENT

This chassis incorporates a 10 kc. filter circuit to eliminate the beat note heard as a whistle between stations on the broadcast band. If the trimmer is out of adjustment, the following procedure should be observed:

1. Set the Selectivity Switch to FULL RANGE by turning the Treble Control knob clockwise as far as possible.

CHASSISCR-321

2. Connect the output of an audio oscillator to the phonograph pickup socket on the radio chassis and adjust the oscillator to EXACTLY 10,000 cycles.
3. Set the band selector to PHONO and adjust the 10 kc. trimmer for minimum output.
4. If an audio oscillator is not available for making this adjustment, set the band selector to BDCST, connect an antenna to the receiver and set the gang condenser to a point between two stations on adjacent channels having approximately the same power. If the 10 kc. trimmer is out of adjustment, a whistle will be heard. Adjust the trimmer until the whistle is eliminated.

FM ALIGNMENT

DISCRIMINATOR ALIGNMENT

1. Tune signal generator to EXACTLY 10.775 mc. and connect to pin 1 of the 6AU6 Limiter tube socket through a .01 mfd. capacitor.
2. Connect a DC vacuum tube voltmeter between point "B" on schematic diagram and ground.
3. Peak both discriminator slugs at 10.775 mc.
4. Retune signal generator to exactly 10.7 mc. and adjust bottom slug for zero volts.
5. The DC voltage at 10.625 mc. should be within 10% of the voltage at 10.775 mc. and of opposite polarity.

Note: If the signal generator is not capable of sufficient output to produce a readable DC voltage, the amplification of the last i-f stage can be used to increase the signal input to the limiter for discriminator alignment. To accomplish this, align the last i-f stage as indicated in "I-F Alignment". Then align discriminator as above leaving the signal generator connected to the grid of the 6BA6 2nd i-f tube.

I-F ALIGNMENT

1. Connect high side of signal generator, through a .01 mfd. capacitor and a 1000 ohm resistor in series, to pin 4 of the 6SG7 2nd i-f tube. Connect low side of generator to chassis.
2. Close gang condenser and connect vacuum tube voltmeter across 220,000 ohm limiter grid resistor; (Point "A" on schematic to ground). Adjust signal generator output until a reading of at least 3 volts is obtained. In order to reduce regeneration caused by the vacuum tube voltmeter leads, a 1-megohm isolating resistor, connected with as short leads as possible to point "A" should be used in series with the vacuum tube voltmeter. Align the 3rd i-f transformer for best peak as indicated on voltmeter.

3. Repeat above for each succeeding transformer by connecting signal generator to signal grid of first i-f tube 6BA6 then to the signal grid of 6BE6 converter. The i-f stages should be aligned in this order.

WARNING—After each i-f stage has been aligned, do not repeak with the signal into the grid of the 6BE6.

ALTERNATE VISUAL ALIGNMENT OF I-F STAGES

1. Replace signal generator with sweep generator having approximately 300 kc. sweep and tune generator to 10.7 mc. Connect oscilloscope across 220,000 ohm limiter grid resistor through a 1-megohm isolating resistor. The order of alignment is the same as when using a vacuum tube voltmeter. Each i-f transformer should be individually aligned for best peak and symmetry.

R-F ALIGNMENT

1. Connect vacuum tube voltmeter across limiter grid resistor as in FM I-F alignment.
2. Ground one side of the FM Antenna by placing a wire jumper from one FM connection on the antenna terminal strip to the ground connection.
3. Connect unmodulated signal generator through a 300 ohm resistor to ungrounded antenna post and chassis, and tune signal generator to 107 mc.
4. Set radio dial to 107 mc. and tune oscillator trimmer to peak output on vacuum tube voltmeter. Adjust signal generator output until a reading of at least 3 volts is obtained.
5. Tune 107 mc. r-f and antenna trimmers for maximum indication on voltmeter—it may be necessary to rock the dial while adjusting the r-f trimmer.

SPECIAL SERVICE INFORMATION

The following information is provided for the service man who has a vacuum tube voltmeter or a similar measuring instrument available.

STAGE GAINS*

Antenna Post to R-F Grid at:	
600 kc.....	5.00
98 mc.....	1.15
R-F Grid to Converter Grid at:	
600 kc.....	14.5
98 mc.....	9.4
R-F on Converter Grid to 455 kc. on I-F Grid at:	
600 kc.....	25.0
98 mc.....	3.2

I-F on Converter Grid to 1st I-F Grid at:	600 kc.....	6.6V.	
455 kc. (gang closed).....	28.0	98 mc.....	6.0V.
1st I-F Grid to 2nd I-F Grid** at:		or 0.3 ma. through 22,000 ohm Oscillator Grid	
455 kc.....	95	Resistor at 600 kc. and 0.27 ma. at 98 mc.	
10.7 mc.....	33		
2nd I-F Grid to Limiter Grid at:			
10.7 mc.....	33.4		

AUDIO GAIN

Voltage required across the Volume Control to produce 0.1 watt speaker output*** at 400 cycles is .016 volt with Input Selector Switch in BDCST setting.

OSCILLATOR OUTPUT VOLTAGE

The DC voltage developed across the Oscillator Grid Resistor:

*Variations of ±20% are permissible. All readings made with sufficient input signal to provide 0.5 watt speaker output. 0.5 speaker output at 400 cycles is equivalent to a reading of 1.25V. as measured by a high resistance AC voltmeter across the voice coil of the speaker
 **Detector Plate on AM.
 ***0.1 watt speaker output at 400 cycles is equivalent to a reading of 0.55 volts as measured by a high resistance AC voltmeter across the voice coil of speaker.

DIAL CORD REPLACEMENT

Two separate drive cables are used in the CR-321 dial assembly. One cable is used to transmit the motion from the tuning knob to the large pulley that is coupled to the condenser gang; the other cable actuates the dial pointer whenever the large pulley on the condenser gang is rotated. Separate instructions for replacing either of these cables is given in the following paragraphs.

of sleeving over a 42-inch length of dial cable. Tie the two ends to the loop end of the cable spring "E" securely so that the cable doubled measures 19⁵/₈ inches end to end excluding spring.

CONDENSER DRIVE CABLE REPLACEMENT

Remove dial assembly after taking out four screws on each side of chassis. Slide a short length (approximately 1/2 inch) of sleeving over one end of a length of dial cable, form a small loop and tie a knot in the manner shown on Figure 1. Tie spring to opposite end of cable making length excluding spring 19 1/2 inches. Hook loop over the metal hook in pulley "D" and lace the cable through the pulley slot and around the pulley in a counterclockwise direction when viewed from the rear of the dial assembly keeping the cable to the rear of the pulley groove. Lace the cable around the smaller diameter portion of the tuning control shaft wrapping 2 1/2 turns from front to back; then around the opposite side of pulley "D" into the pulley through the slot. Hook the end of tension spring "F" in the hole provided in pulley "D", completing this operation.

Place spring hook in top hole and draw cable through slot of pulley "D". Loop one end of cable around pulley "D" in a clockwise direction in front of condenser drive cable (viewing dial assembly from front) then loop the remaining end around pulley in a counterclockwise direction. Secure both ends of cable to chassis at edge of pulley slot with scotch tape, keeping piece of sleeving on remaining loop of cable.

Replace dial assembly and loop cable over pulley "A". While holding cable taut remove scotch tape and loop cable over pulleys "B" and "C" as shown in Figure 1.

DIAL POINTER DRIVE CABLE REPLACEMENT

Remove dial assembly after taking out four screws on each side of chassis. Slip a one-half inch length

Turn the tuning control shaft until the condenser gang is completely meshed and slide the dial pointer on its track until it is in line with the last calibration mark at the low frequency end of the dial. The short piece of sleeving installed prior to the stringing operation should be slid to the rear of the dial pointer and the crimping lug on the pointer pressed over the sleeving. After checking to make certain that the condenser gang is completely meshed and the dial pointer is in the position specified previously, apply a few drops of cement to each end of the sleeving to which the dial pointer is fastened. This completes the operation.

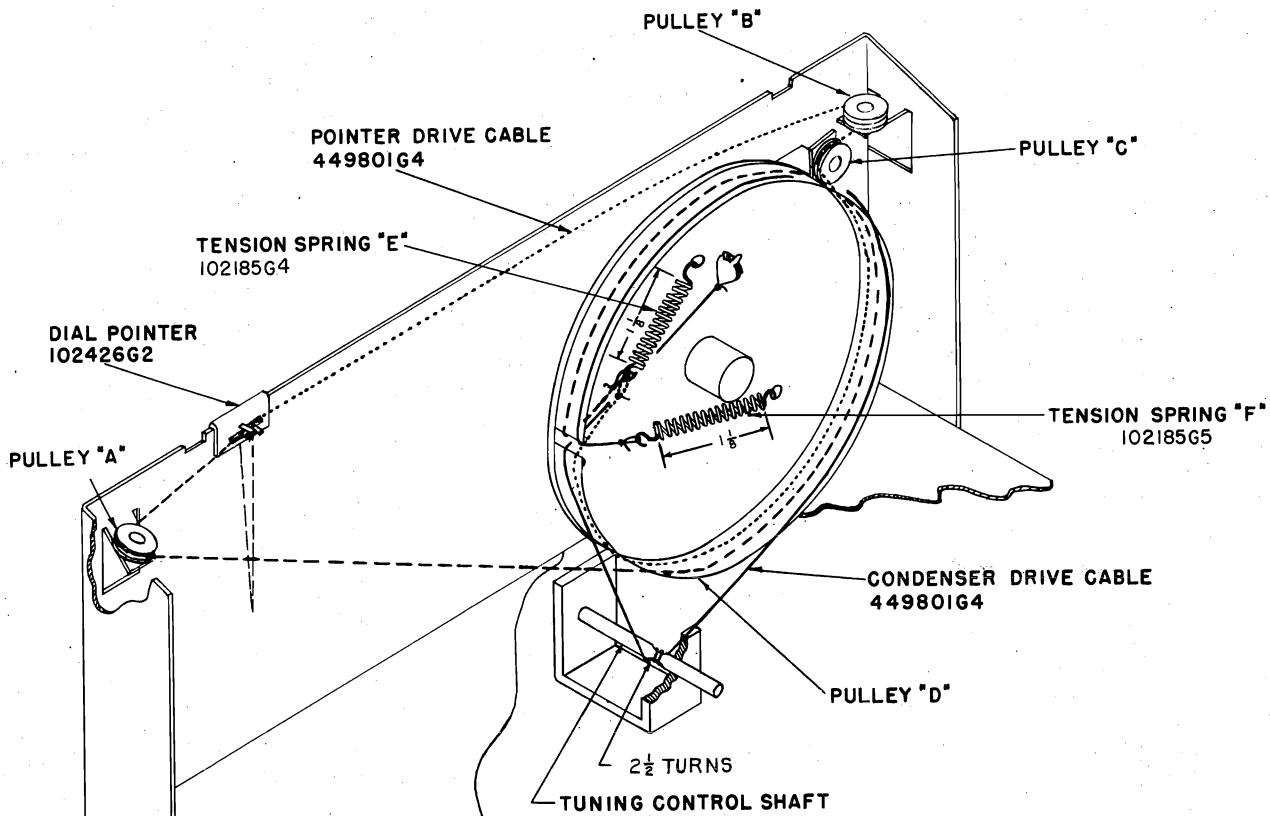
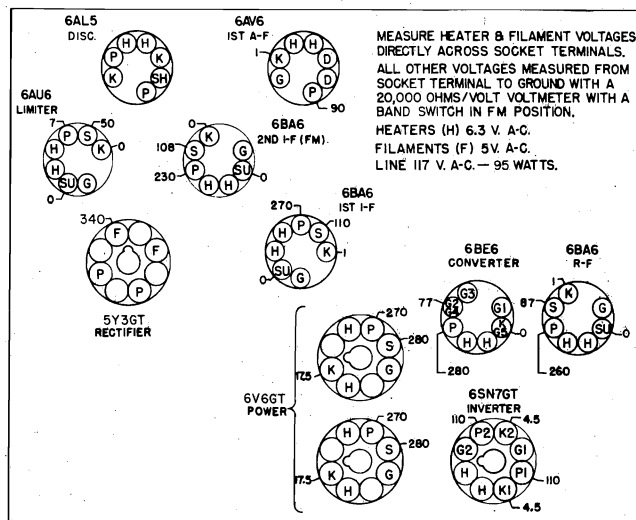

FIGURE 1

I-F'S
 FM 10.7 MC.
 AM 455 KC.

NOTES
 BAND SWITCH SHOWN IN COUNTERCLOCKWISE (FM)
 POSITION WHEN VIEWED FROM THE FRONT PANEL.
 ALL ELECTRICAL VALUES SHOWN ARE IN OHMS OR
 MMF UNLESS OTHERWISE SPECIFIED.
 LETTERS SHOWN IN SQUARES DESIGNATE METER
 CONNECTION POINTS FOR ALIGNMENT DESCRIBED
 IN TEXT.



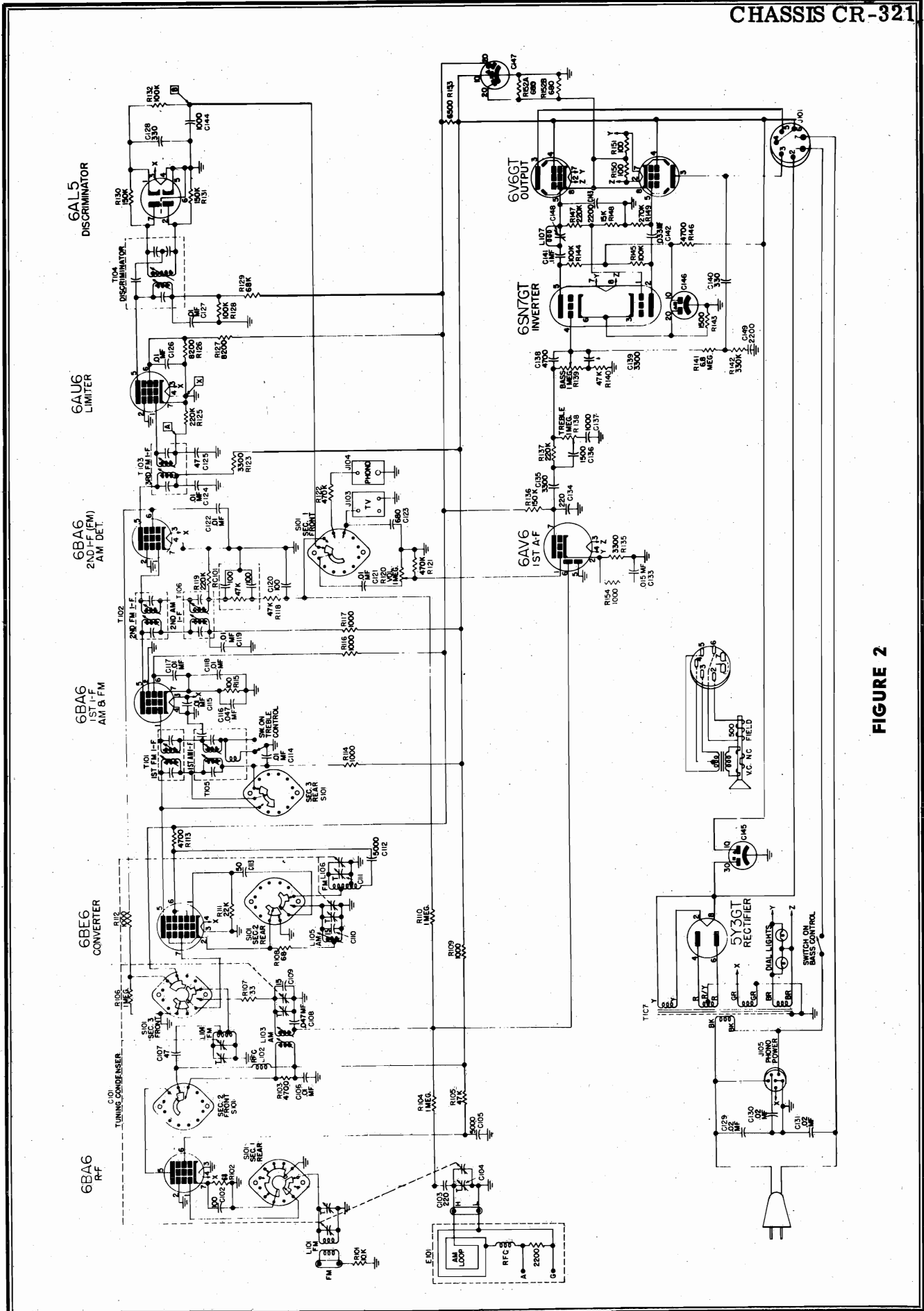

FIGURE 2

CHASSIS CR-321

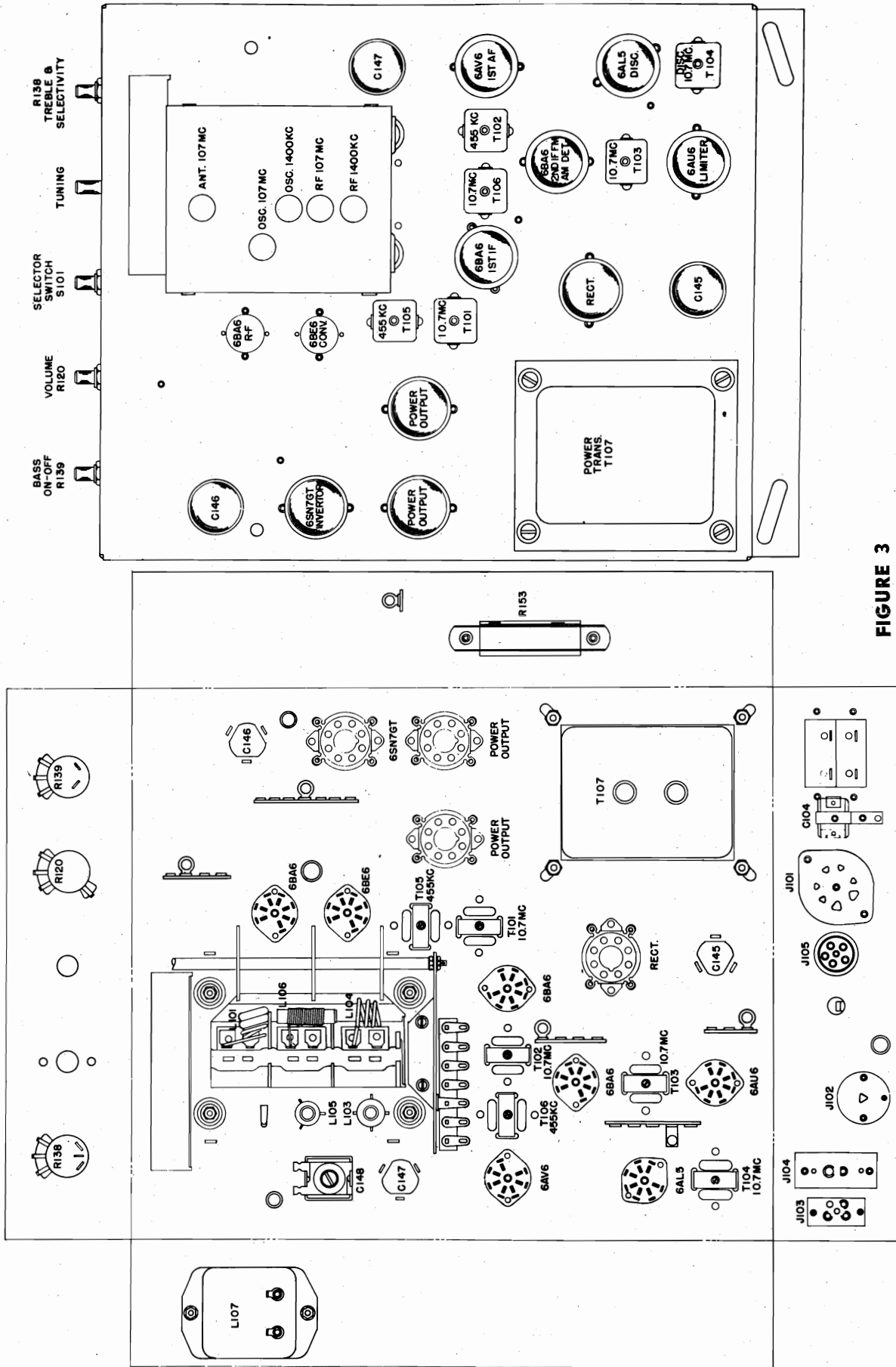

FIGURE 3

PARTS LIST

REFERENCE NO.	DESCRIPTION	MAGNAVOX PART NO.	LIST PRICE
T 101	Transformer, 1st i-f (FM)	360374-1	1.10
T 102	Transformer, 2nd i-f (FM)	360374-1	1.10
T 103	Transformer, 3rd i-f (FM)	360374-1	1.10
T 104	Transformer, discriminator	360375-1	1.40
T 105	Transformer, 1st i-f (AM)	360508-1	1.45
T 106	Transformer, 2nd i-f (AM)	360373-1	1.25
T 107	Transformer, power	300050-2	12.00
L 101	Coil assembly, antenna (FM)	360321-2	.65
L 102	Coil, choke	360284-1	.20
L 103	Coil assembly, r-f (AM)	360348-1	1.00
L 104	Coil assembly, r-f (FM)	360322-2	2.55
L 105	Coil assembly, oscillator (AM)	360407-1	.55
L 106	Coil assembly, oscillator (FM)	360323-1	.90
L 107	Coil assembly, 10 kc.	360244-2	1.55
C 101	Capacitor, tuning	260103-1	5.20
C 102	Capacitor, mica, 100 mmf. 500 V.	250187-53	.15
C 103	Capacitor, mica, 220 mmf. 500 V.	250159-86	.25
C 104	Capacitor, trimmer	250046-2	.20
C 105	Capacitor, ceramic, 5000 mmf.	250175-1	.20
C 106	Capacitor, ceramic, .01 mfd.	250175-2	.20
C 107	Capacitor, mica, 47 mmf. 500 V.	250187-49	.15
C 108	Capacitor, paper, .047 mfd. 200 V.	250205-11	.20
C 109	Capacitor, mica, 15 mmf.	250187-43	.15
C 110	Capacitor, mica, 15 mmf.	250187-43	.15
C 111	Capacitor, trimmer	260067-6	.70
C 112	Capacitor, ceramic, 5000 mmf.	250175-1	.20
C 113	Capacitor, ceramic, 50 mmf. $\pm 10\%$, 500 V.	250088-39	.15
C 114	Capacitor, ceramic, .01 mfd.	250175-2	.20
C 115	Capacitor, ceramic, .01 mfd.	250175-2	.20
C 116	Capacitor, paper, .047 mfd. 200 V.	250205-11	.20
C 117	Capacitor, ceramic, .01 mfd.	250175-2	.20
C 118	Capacitor, ceramic, .01 mfd.	250175-2	.20
C 119	Capacitor, ceramic, .01 mfd.	250175-2	.20
C 120	Capacitor, mica, 100 mmf. 500 V.	250187-53	.15
C 121	Capacitor, paper, .01 mfd. 600 V.	250203-7	.20
C 122	Capacitor, ceramic, .01 mfd.	250175-2	.20
C 123	Capacitor, mica, 680 mmf. $\pm 10\%$, 500 V.	250160-62	.20
C 124	Capacitor, ceramic, .01 mfd.	250175-2	.20
C 125	Capacitor, mica, 47 mmf. 500 V.	250187-49	.15
C 126	Capacitor, ceramic, .01 mfd.	250175-2	.20
C 127	Capacitor, ceramic, .01 mfd.	250175-2	.20
C 128	Capacitor, mica, 330 mmf. 500 V.	250159-88	.25
C 129	Capacitor, paper, .02 mfd. 600 V.	250129-3	.25
C 130	Capacitor, paper, .02 mfd. 600 V.	250129-3	.25
C 131	Capacitor, paper, .02 mfd. 600 V.	250129-3	.25
C 133	Capacitor, paper, .015 mfd. 200 V.	250185-1	.20
C 134	Capacitor, paper, 220 mmf. 500 V.	250159-86	.20
C 135	Capacitor, paper, 3300 mmf. 600 V.	250203-4	.15
C 136	Capacitor, paper, 1500 mmf. 600 V.	250203-2	.15
C 137	Capacitor, paper, 1000 mmf. 600 V.	250203-1	.15
C 138	Capacitor, paper, 4700 mmf. 600 V.	250203-5	.15
C 139	Capacitor, paper, 3300 mmf. 600 V.	250203-4	.15
C 140	Capacitor, mica, 330 mmf. 500 V.	250159-88	.25
C 141	Capacitor, paper, .1 mfd. 600 V.	250203-13	.25
C 142	Capacitor, paper, .033 mfd. 600 V.	250203-10	.20
C 143	Capacitor, paper, 2200 mmf. 600 V.	250203-3	.15
C 144	Capacitor, paper, 1000 mmf. 600 V.	250203-1	.15
C 145	Capacitor, electrolytic, 30-10 mfd. 475 V.	270023-2	1.60
C 146	Capacitor, electrolytic, 20 mfd. 25 V.—10 mfd. 475 V.	270023-13	.85
C 147	Capacitor, electrolytic, 20-10 mfd. 475 V.—20 mfd. 25 V.	270023-12	1.65
C 148	Capacitor, trimmer, 10 kc.	259610-2	.55
C 149	Capacitor, mica, 2200 mmf. 600 V.	250203-3	.15

CHASSIS CR-321

REFERENCE NO.	DESCRIPTION	MAGNAVOX PART NO.	LIST PRICE
R 101	Resistor, carbon, 10,000 ohms, 1/2 W.	230104-74	.05
R 102	Resistor, carbon, 68 ohms, 1/2 W.	230104-48	.05
R 103	Resistor, carbon, 4700 ohms, 1/2 W.	230104-70	.05
R 104	Resistor, carbon, 1 megohm, 1/2 W.	230104-98	.05
R 105	Resistor, carbon, 47,000 ohms, 1 W.	230105-82	.10
R 106	Resistor, carbon, 1 megohm, 1/2 W.	230104-98	.05
R 107	Resistor, carbon, 33 ohms, 1/2 W.	230104-44	.05
R 108	Resistor, carbon, 68 ohms, 1/2 W.	230104-48	.05
R 109	Resistor, carbon, 1000 ohms, 1/2 W.	230104-62	.05
R 110	Resistor, carbon, 1 megohm, 1/2 W.	230104-98	.05
R 111	Resistor, carbon, 22,000 ohms, 1/2 W.	230104-78	.05
R 112	Resistor, carbon, 1000 ohms, 1/2 W.	230104-62	.05
R 113	Resistor, carbon, 4700 ohms, 1/2 W.	230104-70	.05
R 114	Resistor, carbon, 1000 ohms, 1/2 W.	230104-62	.05
R 115	Resistor, carbon, 100 ohms, 1/2 W.	230104-50	.05
R 116	Resistor, carbon, 1000 ohms, 1/2 W.	230104-62	.05
R 117	Resistor, carbon, 1000 ohms, 1/2 W.	230104-62	.05
R 118	Resistor, carbon, 47,000 ohms, 1/2 W.	230104-82	.05
R 119	Resistor, carbon, 220,000 ohms, 1/2 W.	230104-90	.05
R 120	Potentiometer, volume control	220074-1	.65
R 121	Resistor, carbon, 470,000 ohms, 1/2 W.	230104-94	.05
R 122	Resistor, carbon, 470,000 ohms, 1/2 W.	230104-94	.05
R 123	Resistor, carbon, 3300 ohms, 1 W.	230105-68	.05
R 125	Resistor, carbon, 220,000 ohms, 1/2 W.	230104-90	.05
R 126	Resistor, carbon, 8200 ohms, 1 W.	230105-73	.05
R 127	Resistor, carbon, 8200 ohms, 1 W.	230105-73	.05
R 128	Resistor, carbon, 100,000 ohms, 1/2 W.	230104-86	.05
R 129	Resistor, carbon, 68,000 ohms, 1/2 W.	230104-84	.05
R 130	Resistor, carbon, 150,000 ohms, 1/2 W.	230104-88	.05
R 131	Resistor, carbon, 150,000 ohms, 1/2 W.	230104-88	.05
R 132	Resistor, carbon, 100,000 ohms, 1/2 W.	230104-86	.05
R 135	Resistor, carbon, 3300 ohms, 1/2 W.	230104-68	.05
R 136	Resistor, carbon, 150,000 ohms, 1/2 W.	230104-88	.05
R 137	Resistor, carbon, 330,000 ohms, 1/2 W.	230104-90	.05
R 138	Potentiometer, treble control, 1 megohm	220071-4	1.15
R 139	Potentiometer, bass control, 1 megohm	220073-18	.80
R 140	Resistor, carbon, 47,000 ohms, 1/2 W.	230104-82	.05
R 141	Resistor, carbon, 6.8 megohm, 1/2 W.	230104-108	.05
R 142	Resistor, carbon, 330,000 ohms, 1/2 W.	230104-92	.05
R 143	Resistor, carbon, 1500 ohms, 1/2 W.	230104-64	.05
R 144	Resistor, carbon, 100,000 ohms, 1 W.	230105-86	.10
R 145	Resistor, carbon, 100,000 ohms, 1 W.	230105-86	.10
R 146	Resistor, carbon, 4700 ohms, 1/2 W.	230104-70	.05
R 147	Resistor, carbon, 220,000 ohms, ±5%, 1/2 W.	230094-215	.10
R 148	Resistor, carbon, 15,000 ohms, ±5%, 1/2 W.	230094-187	.10
R 149	Resistor, carbon, 270,000 ohms, 1/2 W.	230104-91	.05
R 150	Resistor, carbon, 100 ohms, 1/2 W.	230104-50	.05
R 151	Resistor, carbon, 100 ohms, 1/2 W.	230104-50	.05
R 152a	Resistor, carbon, 680 ohms, 1 W.	230105-60	.10
R 152b	Resistor, carbon, 680 ohms, 1 W.	230105-60	.10
R 153	Resistor, wire wound, 6500 ohms	240035-9	.50
R 154	Resistor, carbon, 1000 ohms, 1/2 W.	230104-62	.05
RC 101	Printed circuit (capacitor-resistor filter)	250170-1	.30
S 101	Selector switch	160194-1	2.25
J 101	Socket, speaker	180504-16	.15
J 103	Socket, T.V.	180060-1	.10
J 104	Socket, phono	189741-1	.10
J 105	Socket, phono power	180520-4	.20
F 101	Loop antenna	*	

*The part number of the Loop Antenna Assembly changes with different cabinets. It is therefore important that you specify the style number of the instrument when ordering a replacement Loop Antenna Assembly.

ALL PRICES SUBJECT TO CHANGE WITHOUT NOTICE

SPECIFICATIONS

Power supply.....	117 volts 50/60 cycles AC
Power consumption.....	160 watts
Power output.....	20 watts
Intermediate frequency.....	455 kc./10.7 mc.
Tuning frequency range:	
Broadcast Band.....	540-1620 kc.
FM Band.....	88-108 mc.
Tubes:	
R-F Amplifier.....	6BA6
Converter.....	6BE6
1st I-F Amplifier (AM-FM).....	6BA6
2nd I-F (FM), Detector and AVC (AM).....	6BA6
Limiter.....	6AU6
Discriminator.....	6AL5
First Audio.....	6AV6
Inverter.....	6SN7GT
Power output (push-pull stage).....	(2) 6L6
Rectifier.....	5U4G
Tuning Indicator.....	6U5
Dial Lamps.....	Mazda No. 44
Speaker: coaxial.....	15" Dynamic 5" PM
Field coil resistance.....	500 ohms None
Voice coil impedance (400 cycles).....	15 ohms 3.8 ohms
Output transformer.....	5000/15

ALIGNMENT PROCEDURE

Alignment of these receivers requires the use of an accurately calibrated r-f signal generator, range 455 kc. to 107 mc., an output meter, and a vacuum tube voltmeter of greater than 10 megohm input impedance. All trimmer condensers can be identified by stampings on the chassis and gang condenser cover and are shown on the chassis layout diagram.

The pointer on the radio dial should line up with the first vertical mark on the low frequency end of the dial glass. If the pointer does not line up, loosen the pointer on the dial string and move it to correct position. Re-tighten and re-cement the pointer to the string. Be sure the gang is fully meshed for this pointer alignment. Align AM first.

AM ALIGNMENT

I-F ALIGNMENT

1. Set treble control to SHARP TUNE position. Set volume and bass controls to maximum, the Band Switch to Broadcast position, and dial pointer to 1000 kc.
2. Tune the signal generator to EXACTLY 455 kc.

3. Connect output of modulated signal generator to the signal grid of the 6BE6 (pin 7) through a .01 mfd. capacitor and signal generator ground to radio chassis.

4. AM and FM i-f transformers on these models are separate and can be identified on the chassis layout diagram Figure 3.

5. Connect output meter across voice coil of speaker and adjust the i-f transformers for peak output as indicated on the output meter.

ALTERNATE VISUAL ALIGNMENT OF I-F STAGES

1. Connect 455 kc. sweep generator having approximately 20 kc. sweep to signal grid of 6BE6 (pin 7) through a .01 mfd. capacitor. Connect an oscilloscope through a 1 megohm isolating resistor across the 220,000 ohm diode load resistor. Align for best possible peak in sharp tune position and symmetry in full range position.

R-F ALIGNMENT

1. Remove the signal generator lead from the 6BE6 grid and connect it across H and L on terminal strip on the rear of the chassis. The high side of the signal generator should be connected to H and the signal generator ground to L.

2. Set the signal generator and the radio receiver to 1400 kc., adjust the 1400 kc. oscillator trimmer and the 1400 kc. r-f trimmer for maximum output.

3. Set the signal generator and radio receiver to 600 kc. Adjust the oscillator and r-f coil slugs for maximum output. If considerable adjustment was necessary re-check the 1400 kc. trimmer settings.

4. Replace chassis in cabinet and connect loop antenna leads to proper terminals on the rear of the chassis.

5. Form three turns of wire into a loop, connect this loop to the signal generator and loosely couple it to the receiver loop antenna.

6. With the signal generator and dial at 1400 kc. adjust the loop antenna trimmer for maximum output.

10 KC. FILTER ADJUSTMENT

This chassis incorporates a 10 kc. filter circuit to eliminate the beat note heard as a whistle between stations on the broadcast band. If the trimmer is out of adjustment, the following procedure should be observed:

CHASSIS CR-322

1. Adjust the treble control switch to the No. 4 setting.
2. Connect the output of an audio oscillator to the phonograph pickup socket on the radio chassis and adjust the oscillator to EXACTLY 10,000 cycles.
3. Set the band selector to PHONO and adjust the 10 kc. trimmer for minimum output.
4. If an audio oscillator is not available for making this adjustment set the band selector to BDCST, set the treble control to position 4, connect the antenna to the receiver and set the gang condenser to a point between two stations on adjacent channels having approximately the same power. If the 10 kc. trimmer is out of adjustment, a whistle will be heard. Adjust the trimmer until the whistle is eliminated.

FM ALIGNMENT

DISCRIMINATOR ALIGNMENT

1. Tune signal generator to EXACTLY 10.775 mc. and connect to pin 1 of the 6AU6 Limiter tube socket through a .01 mfd. capacitor.
2. Connect a DC vacuum tube voltmeter between point "B" on schematic diagram and ground.
3. Peak both discriminator slugs at 10.775 mc.
4. Retune signal generator to exactly 10.7 mc. and adjust bottom slug for zero volts.
5. The DC voltage at 10.625 mc. should be within 10% of the voltage at 10.775 mc. and of opposite polarity.

Note: If the signal generator is not capable of sufficient output to produce a readable DC voltage, the amplification of the last i-f stage can be used to increase the signal input to the limiter for discriminator alignment. To accomplish this, align the last i-f stage as indicated in "I-F Alignment". Then align discriminator as above leaving the signal generator connected to the grid of the 6BA6 2nd i-f tube.

I-F ALIGNMENT

1. Connect high side of signal generator, through a .01 mfd. capacitor and a 1000 ohm resistor in series, to pin 1 of the 6BA6 2nd i-f tube. Connect low side of generator to chassis.
2. Close gang condenser and connect vacuum tube voltmeter across 220,000 ohm limiter grid resistor; (Point "A" on schematic to ground). Adjust signal generator output until a reading of at least 3 volts is obtained. In order to reduce regeneration caused by

the vacuum tube voltmeter leads, a 1-megohm isolating resistor, connected with as short leads as possible to point "A" should be used in series with the vacuum tube voltmeter. Align the 3rd i-f transformer for best peak as indicated on voltmeter.

3. Repeat above for each succeeding transformer by connecting signal generator to signal grid of first i-f tube 6BA6 then to the signal grid of 6BE6 converter. The i-f stages should be aligned in this order.

WARNING—After each i-f stage has been aligned, do not repeak with the signal into the grid of the 6BE6.

ALTERNATE VISUAL ALIGNMENT OF I-F STAGES

1. Replace signal generator with sweep generator having approximately 300 kc. sweep and tune generator to 10.7 mc. Connect oscilloscope across 220,000 ohm limiter grid resistor through a 1-megohm isolating resistor. The order of alignment is the same as when using a vacuum tube voltmeter. Each i-f transformer should be individually aligned for best peak and symmetry.

R-F ALIGNMENT

1. Connect vacuum tube voltmeter across limiter grid resistor as in FM I-F alignment.
2. Ground one side of the FM Antenna by placing a wire jumper from one FM connection on the antenna terminal strip to the ground connection.
3. Connect unmodulated signal generator through a 300 ohm resistor to ungrounded antenna post and chassis, and tune signal generator to 107 mc.
4. Set radio dial to 107 mc. and tune oscillator trimmer to peak output on vacuum tube voltmeter. Adjust signal generator output until a reading of at least 3 volts is obtained.
5. Tune 107 mc. r-f and antenna trimmers for maximum indication on voltmeter—it may be necessary to rock the dial while adjusting the r-f trimmer.

SPECIAL SERVICE INFORMATION

The following information is provided for the service man who has a vacuum tube voltmeter or a similar measuring instrument available.

STAGE GAINS*

Antenna Post to R-F Grid at:

600 kc.....	5.00
98 mc.....	1.15

R-F Grid to Converter Grid at:	
600 kc.....	14.5
98 mc.....	9.4
R-F on Converter Grid to 455 kc. on I-F Grid at:	
600 kc.....	25.0
98 mc.....	3.2
I-F on Converter Grid to 1st I-F Grid at:	
455 kc. (gang closed).....	28.0
1st I-F Grid to 2nd I-F Grid** at:	
455 kc.....	95
10.7 mc.....	33
2nd I-F Grid to Limiter Grid at:	
10.7 mc.....	33.4

OSCILLATOR OUTPUT VOLTAGE

The DC voltage developed across the Oscillator Grid Resistor:

600 kc.....	6.6V.
98 mc.....	6.0V.

or 0.3 ma. through 22,000 ohm Oscillator Grid Resistor at 600 kc. and 0.27 ma. at 98 mc.

AUDIO GAIN

Voltage required across the Volume Control to produce 0.1 watt speaker output*** at 400 cycles is .016 volt with Input Selector Switch in BDCST setting.

*Variations of $\pm 20\%$ are permissible. All readings made with sufficient input signal to provide 0.5 watt speaker output. 0.5 watt speaker output at 400 cycles is equivalent to a reading of 2.74 V. as measured by a high resistance AC voltmeter across the output transformer secondary.

**Detector Plate on AM.

***0.1 watt speaker output at 400 cycles is equivalent to a reading of 1.25 volts as measured by a high resistance AC voltmeter across the voice coil of speaker.

DIAL CORD REPLACEMENT

Two separate drive cables are used in the CR-322 dial assembly. One cable is used to transmit the motion from the tuning knob to the large pulley that is coupled to the gang condenser; the other cable actuates the dial pointer whenever the large pulley on the gang condenser is rotated. Separate instructions for replacing either of these cables is given in the following paragraphs.

CONDENSER DRIVE CABLE REPLACEMENT

Remove dial assembly after taking out four screws on each side of chassis. Slide a short length (approximately $\frac{1}{2}$ inch) of sleeving over one end of a length of dial cable, form a small loop and tie a knot in the manner shown on Figure 1. Tie spring to opposite

end of cable making length excluding spring $19\frac{1}{2}$ inches. Hook loop over the metal hook in pulley "D" and lace the cable through the pulley slot and around the pulley in a counterclockwise direction when viewed from the rear of the dial assembly keeping the cable to the rear of the pulley groove. Lace the cable around the smaller diameter portion of the tuning control shaft wrapping $2\frac{1}{2}$ turns from front to back; then around the opposite side of pulley "D" into the pulley through the slot. Hook the end of tension spring "F" in the hole provided in pulley "D", completing this operation.

DIAL POINTER DRIVE CABLE REPLACEMENT

Remove dial assembly after taking out four screws on each side of chassis. Slip a one-half inch length of sleeving over a 42-inch length of dial cable. Tie the two ends to the loop end of the cable spring "E" securely so that the cable doubled measures $19\frac{5}{8}$ inches end to end excluding spring.

Place spring hook in top hole and draw cable through slot of pulley "D". Loop one end of cable around pulley "D" in a clockwise direction in front of condenser drive cable (viewing dial assembly from front) then loop the remaining end around pulley in a counterclockwise direction. Secure both ends of cable to chassis at edge of pulley slot with scotch tape, keeping piece of sleeving on remaining loop of cable.

Replace dial assembly and loop cable over pulley "A". While holding cable taut remove scotch tape and loop cable over pulleys "B" and "C" as shown in Figure 1.

Turn the tuning control shaft until the gang condenser is completely meshed and slide the dial pointer on its track until it is in line with the last calibration mark at the low frequency end of the dial. The short piece of sleeving installed prior to the stringing operation should be slid to the rear of the dial pointer and the crimping lug on the pointer pressed over the sleeving. After checking to make certain that the gang condenser is completely meshed and the dial pointer is in the position specified previously, apply a few drops of cement to each end of the sleeving to which the dial pointer is fastened. This completes the operation.

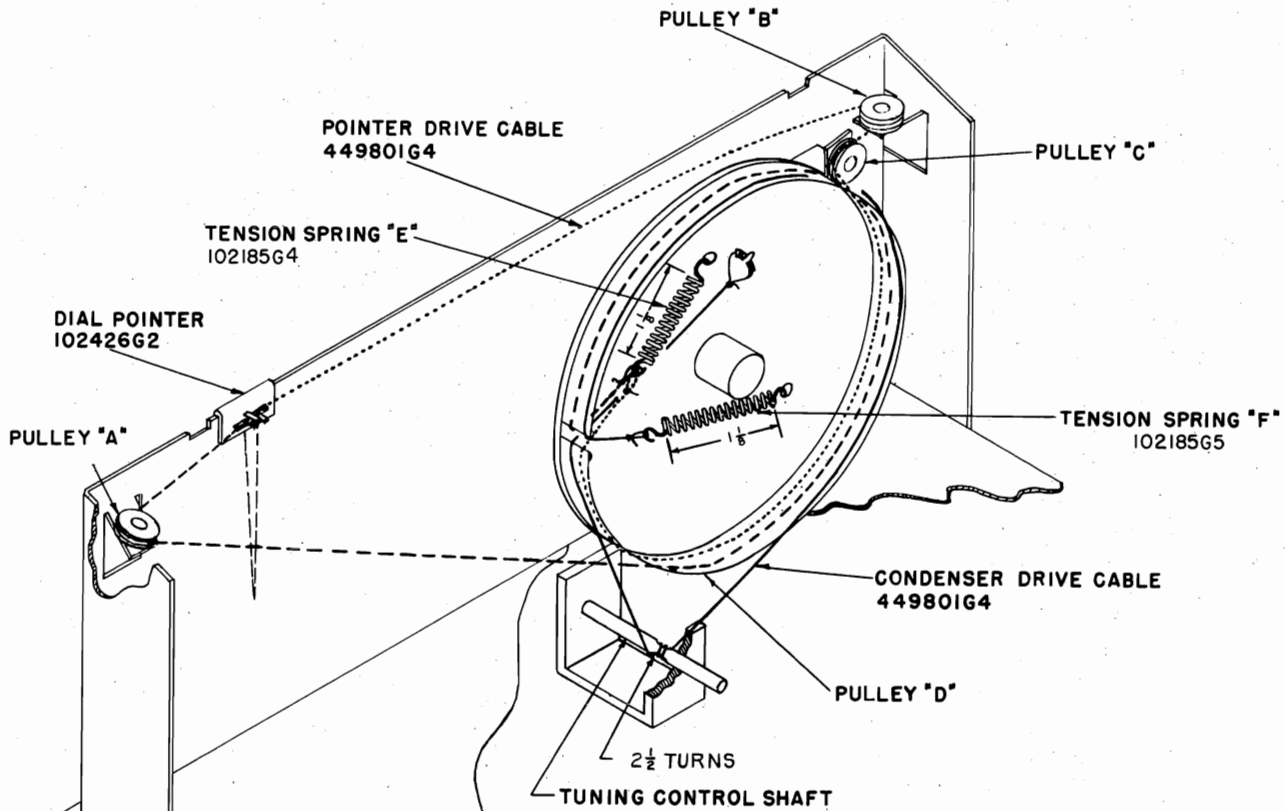
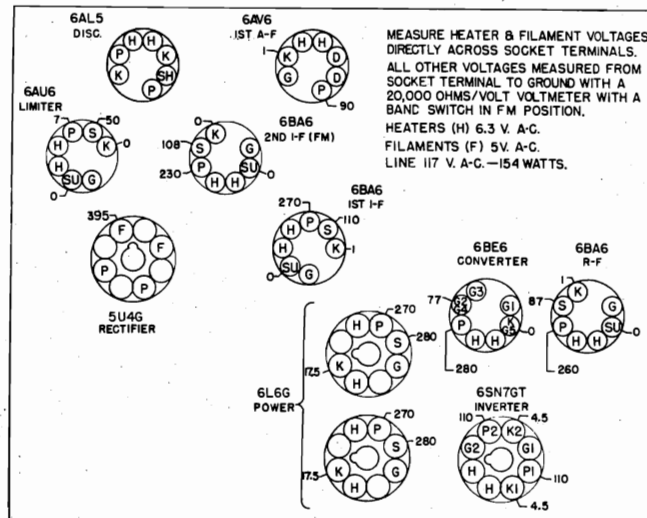
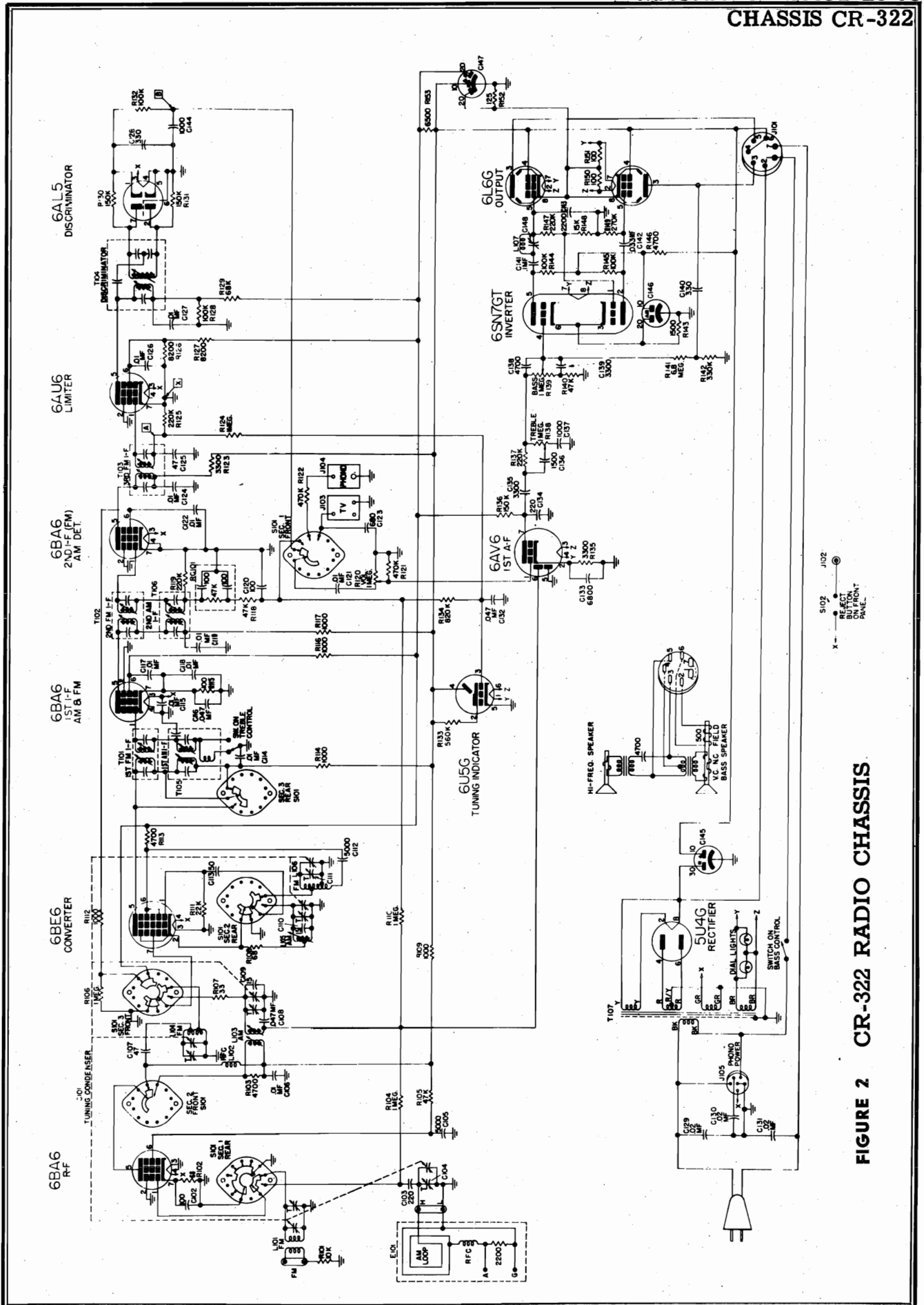

FIGURE 1

I-F'S
 FM 10.7 MC.
 AM 455 KC.

NOTES
 BAND SWITCH SHOWN IN COUNTERCLOCKWISE (FM) POSITION WHEN VIEWED FROM THE FRONT PANEL.
 ALL ELECTRICAL VALUES SHOWN ARE IN OHMS OR MMF UNLESS OTHERWISE SPECIFIED.
 LETTERS SHOWN IN SQUARES DESIGNATE METER CONNECTION POINTS FOR ALIGNMENT DESCRIBED IN TEXT.





5102
J102
X -
BUTTON
ON FRONT
PANEL

FIGURE 2 CR-322 RADIO CHASSIS

CHASSIS CR-322

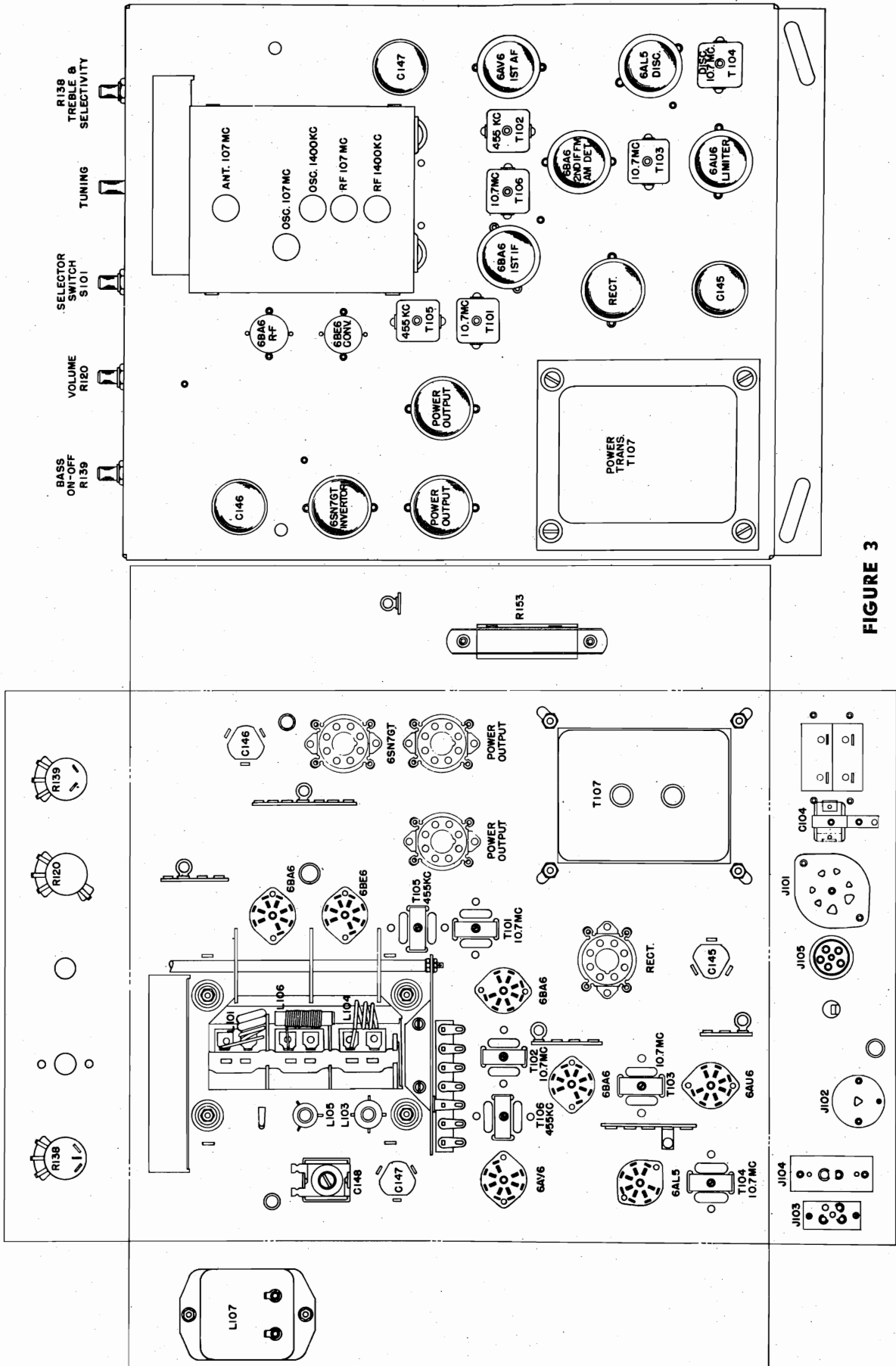

FIGURE 3

REFERENCE NO.	PARTS LIST DESCRIPTION	MAGNAVOX PART NO.	LIST PRICE
T 101	Transformer, 1st i-f (FM)	360374-1	\$ 1.10
T 102	Transformer, 2nd i-f (FM)	360374-1	1.10
T 103	Transformer, 3rd i-f (FM)	360374-1	1.10
T 104	Transformer, discriminator	360375-1	1.40
T 105	Transformer, 1st i-f (AM)	360508-1	1.45
T 106	Transformer, 2nd i-f (AM)	360373-1	1.25
T 107	Transformer, power	300052-2	12.25
L 101	Coil assembly, antenna (FM)	360321-2	.65
L 102	Coil, choke	360284-1	.20
L 103	Coil assembly, r-f (AM)	360348-1	1.00
L 104	Coil assembly, r-f (FM)	360322-2	2.55
L 105	Coil assembly, oscillator (AM)	360407-1	.55
L 106	Coil assembly, oscillator (FM)	360323-1	.90
L 107	Coil assembly, 10 kc.	360244-2	1.55
C 101	Capacitor, tuning	260103-1	5.20
C 102	Capacitor, mica, 100 mmf. 500 V.	250187-53	.15
C 103	Capacitor, mica, 220 mmf. 500 V.	250159-86	.25
C 104	Capacitor, trimmer	250046-2	.20
C 105	Capacitor, ceramic, 5000 mmf.	250175-1	.20
C 106	Capacitor, ceramic, .01 mfd.	250175-2	.20
C 107	Capacitor, mica, 47 mmf. 500 V.	250187-49	.15
C 108	Capacitor, paper, .047 mfd. 200 V.	250205-11	.20
C 109	Capacitor, mica, 15 mmf.	250187-43	.15
C 110	Capacitor, mica, 15 mmf.	250187-43	.15
C 111	Capacitor, trimmer	260067-6	.70
C 112	Capacitor, ceramic, 5000 mmf.	250175-1	.20
C 113	Capacitor, ceramic, 50 mmf. $\pm 10\%$, 500 V.	250088-39	.15
C 114	Capacitor, ceramic, .01 mfd.	250175-2	.20
C 115	Capacitor, ceramic, .01 mfd.	250175-2	.20
C 116	Capacitor, paper, .047 mfd. 200 V.	250205-11	.20
C 117	Capacitor, ceramic, .01 mfd.	250175-2	.20
C 118	Capacitor, ceramic, .01 mfd.	250175-2	.20
C 119	Capacitor, ceramic, .01 mfd.	250175-2	.20
C 120	Capacitor, mica, 100 mmf. 500 V.	250187-53	.15
C 121	Capacitor, paper, .01 mfd. 600 V.	250203-7	.20
C 122	Capacitor, ceramic, .01 mfd.	250175-2	.20
C 123	Capacitor, mica, 680 mmf. $\pm 10\%$, 500 V.	250160-62	.20
C 124	Capacitor, ceramic, .01 mfd.	250175-2	.20
C 125	Capacitor, mica, 47 mmf. 500 V.	250187-49	.15
C 126	Capacitor, ceramic, .01 mfd.	250175-2	.20
C 127	Capacitor, ceramic, .01 mfd.	250175-2	.20
C 128	Capacitor, mica, 330 mmf. 500 V.	250159-88	.25
C 129	Capacitor, paper, .02 mfd. 600 V.	250129-3	.25
C 130	Capacitor, paper, .02 mfd. 600 V.	250129-3	.25
C 131	Capacitor, paper, .02 mfd. 600 V.	250129-3	.25
C 132	Capacitor, paper, .047 mfd. 200 V.	250205-11	.20
C 133	Capacitor, paper, 6800 mmf. 600 V.	250203-6	.15
C 134	Capacitor, paper, 220 mmf. 500 V.	250159-86	.20
C 135	Capacitor, paper, 3300 mmf. 600 V.	250203-4	.15
C 136	Capacitor, paper, 1500 mmf. 600 V.	250203-2	.15
C 137	Capacitor, paper, 1000 mmf. 600 V.	250203-1	.15
C 138	Capacitor, paper, 4700 mmf. 600 V.	250203-5	.15
C 139	Capacitor, paper, 3300 mmf. 600 V.	250203-4	.15
C 140	Capacitor, mica, 330 mmf. 500 V.	250159-88	.25
C 141	Capacitor, paper, .1 mfd. 600 V.	250203-13	.25
C 142	Capacitor, paper, .033 mfd. 600 V.	250203-10	.20
C 143	Capacitor, paper, 2200 mmf. 600 V.	250203-3	.15
C 144	Capacitor, paper, 1000 mmf. 600 V.	250203-1	.15
C 145	Capacitor, electrolytic, 30-10 mfd. 475 V.	270023-2	1.60
C 146	Capacitor, electrolytic, 20 mfd. 25 V.—10 mfd. 475 V.	270023-13	.85
C 147	Capacitor, electrolytic, 20-10 mfd. 475 V.—20 mfd. 25 V.	270023-12	1.65
C 148	Capacitor, trimmer, 10 kc.	259610-2	.55
R 101	Resistor, carbon, 10,000 ohms, $\frac{1}{2}$ W.	230104-74	.05

CHASSIS CR-322	REFERENCE NO.	DESCRIPTION	MAGNAVOX PART NO.	LIST PRICE
	R 102	Resistor, carbon, 68 ohms, 1/2 W.	230104-48	.05
	R 103	Resistor, carbon, 4700 ohms, 1/2 W.	230104-70	.05
	R 104	Resistor, carbon, 1 megohm, 1/2 W.	230104-98	.05
	R 105	Resistor, carbon, 47,000 ohms, 1 W.	230105-82	.10
	R 106	Resistor, carbon, 1 megohm, 1/2 W.	230104-98	.05
	R 107	Resistor, carbon, 33 ohms, 1/2 W.	230104-44	.05
	R 108	Resistor, carbon, 68 ohms, 1/2 W.	230104-48	.05
	R 109	Resistor, carbon, 1000 ohms, 1/2 W.	230104-62	.05
	R 110	Resistor, carbon, 1 megohm, 1/2 W.	230104-98	.05
	R 111	Resistor, carbon, 22,000 ohms, 1/2 W.	230104-78	.05
	R 112	Resistor, carbon, 1000 ohms, 1/2 W.	230104-62	.05
	R 113	Resistor, carbon, 4700 ohms, 1/2 W.	230104-70	.05
	R 114	Resistor, carbon, 1000 ohms, 1/2 W.	230104-62	.05
	R 115	Resistor, carbon, 100 ohms, 1/2 W.	230104-50	.05
	R 116	Resistor, carbon, 1000 ohms, 1/2 W.	230104-62	.05
	R 117	Resistor, carbon, 1000 ohms, 1/2 W.	230104-62	.05
	R 118	Resistor, carbon, 47,000 ohms, 1/2 W.	230104-82	.05
	R 119	Resistor, carbon, 220,000 ohms, 1/2 W.	230104-90	.05
	R 120	Potentiometer, volume control	220074-1	.65
	R 121	Resistor, carbon, 470,000 ohms, 1/2 W.	230104-94	.05
	R 122	Resistor, carbon, 470,000 ohms, 1/2 W.	230104-94	.05
	R 123	Resistor, carbon, 3300 ohms, 1 W.	230105-68	.05
	R 124	Resistor, carbon, 1 megohm, 1/2 W.	230104-98	.05
	R 125	Resistor, carbon, 220,000 ohms, 1/2 W.	230104-90	.05
	R 126	Resistor, carbon, 8200 ohms, 1 W.	230105-73	.05
	R 127	Resistor, carbon, 8200 ohms, 1 W.	230105-73	.05
	R 128	Resistor, carbon, 100,000 ohms, 1/2 W.	230104-86	.05
	R 129	Resistor, carbon, 68,000 ohms, 1/2 W.	230104-84	.05
	R 130	Resistor, carbon, 150,000 ohms, 1/2 W.	230104-88	.05
	R 131	Resistor, carbon, 150,000 ohms, 1/2 W.	230104-88	.05
	R 132	Resistor, carbon, 100,000 ohms, 1/2 W.	230104-86	.05
	R 133	Resistor, carbon, 560,000 ohms, 1/2 W. (in tuning eye)	230104-95	.05
	R 134	Resistor, carbon, 820,000 ohms, 1/2 W.	230104-97	.05
	R 135	Resistor, carbon, 3300 ohms, 1/2 W.	230104-68	.05
	R 136	Resistor, carbon, 150,000 ohms, 1/2 W.	230104-88	.05
	R 137	Resistor, carbon, 220,000 ohms, 1/2 W.	230104-90	.05
	R 138	Potentiometer, treble control, 1 megohm	220071-4	1.15
	R 139	Potentiometer, bass control, 1 megohm	220073-18	.80
	R 140	Resistor, carbon, 47,000 ohms, 1/2 W.	230104-82	.05
	R 141	Resistor, carbon, 6.8 megohm, 1/2 W.	230104-108	.05
	R 142	Resistor, carbon, 330,000 ohms, 1/2 W.	230104-92	.05
	R 143	Resistor, carbon, 1500 ohms, 1/2 W.	230104-64	.05
	R 144	Resistor, carbon, 100,000 ohms, 1 W.	230105-86	.10
	R 145	Resistor, carbon, 100,000 ohms, 1 W.	230105-86	.10
	R 146	Resistor, carbon, 4700 ohms, 1/2 W.	230104-70	.05
	R 147	Resistor, carbon, 220,000 ohms, ±5%, 1/2 W.	230094-215	.10
	R 148	Resistor, carbon, 15,000 ohms, ±5%, 1/2 W.	230094-187	.10
	R 149	Resistor, carbon, 270,000 ohms, 1/2 W.	230104-91	.05
	R 150	Resistor, carbon, 100 ohms, 1/2 W.	230104-50	.05
	R 151	Resistor, carbon, 100 ohms, 1/2 W.	230104-50	.05
	R 152	Resistor, wire wound, 125 ohms, 5 W.	240021-11	.55
	R 153	Resistor, wire wound, 6500 ohms	240035-9	.50
	RC 101	Printed circuit (capacitor-resistor filter)	250170-1	.30
	S 101	Selector switch	160194-1	2.25
	S 102	Switch, reject	160224-1	.50
	J 101	Socket, speaker	180504-16	.15
	J 102	Socket, reject	182776-1	.05
	J 103	Socket, T.V.	180060-1	.10
	J 104	Socket, phono	189741-1	.10
	J 105	Socket, phono power	180520-4	.20
	E 101	Loop antenna	*	

*The part number of the Loop Antenna Assembly changes with different cabinets. It is therefore important that you specify the style number of the instrument when ordering a replacement Loop Antenna Assembly.

ALL PRICES SUBJECT TO CHANGE WITHOUT NOTICE

SPECIFICATIONS

Intermediate frequency.....	455 kc.
Tuning frequency range:	
Broadcast band.....	530—1610 kc.
Short wave band.....	4.9—18.1 mc.
Tubes:	
R-F Amplifier	6SK7
Converter	6SA7
I-F Amplifier	6SK7
Detector and AVC.....	6J5
First Audio	6J5
Second Audio	6J5
Tuning Indicator	6U5
Dial lamps	Mazda No. 51

GENERAL

Model CR-188 radio chassis is a two-band tuner that must be used in conjunction with a power amplifier, such as the Model AMP-101 for speaker operation. Heater and plate voltages for the CR-188 radio chas-

sis are supplied from the amplifier chassis; it is therefore essential that the radio and amplifier chassis be interconnected during alignment or for other electrical service operations.

METHOD FOR REMOVING CHASSIS FROM CABINET

Model CR-188 radio chassis is designed for easy removal from the cabinet in which it is installed. As the radio panel is permanently fastened to the chassis, the control knobs need not be removed when the chassis is taken out of the cabinet for service. To remove the chassis, first remove the antenna leads from their terminals and all plugs from the receptacles on the rear of the chassis. Then remove the two Phillips-head screws from the angular slots in the flange at the rear of the chassis. Lift the rear of the chassis about one inch and pull it straight back. Never remove the chassis tray from the cabinet—it has been properly positioned to bring the radio panel in place when the chassis is replaced. In replacing the chassis, slide it so that the small hooks near the front, ride inside the flanges on the

sides of the chassis tray. Push the chassis forward as far as it will go and the hooks should then engage the slots in the chassis tray. Replace the two Phillips-head screws and nuts and tighten securely. Replace all plugs in their receptacles and the antenna leads on their correct terminals. The antenna terminal board for the loop antenna connections is designated S-L-H. The end of the short wave antenna that is fastened to the inside of the cabinet connects to S. Always disconnect this antenna from terminal S when an outdoor antenna is used as it may pick up noise. The two terminals on the loop are designated L and H. The leads connected to these terminals should be wired to the corresponding terminals (L and H) on the chassis.

ALIGNMENT PROCEDURE

The alignment of this receiver requires the use of an accurately calibrated r-f signal generator and an output meter. All trimmer condenser locations are shown on the chassis layout diagram, Figure 5. The radio volume control should be turned to maximum and the signal generator output kept as low as possible during alignment to prevent the AVC from operating and giving false readings. *Always set the Treble Control to SHARP TUNE before aligning the i-f stages.* This is done by turning the Treble Control Knob to the No. 1 position.

I-F ALIGNMENT

1. Connect the output of the signal generator to the oscillator grid (pin No. 5) of the 6SA7 tube through a .00025 mfd. capacitor. The ground on the signal generator should be connected to the radio chassis ground.
 2. Turn the condenser gang until it is completely meshed, (low-frequency end of dial calibration) and set the band selector switch to BDCST as for broadcast band reception.
 3. Adjust the signal generator to EXACTLY 455 kc. and peak the second i-f transformer and the first i-f transformer trimmers in that order.
- On early models of the CR-188 chassis, the two i-f trimmers are located in the top of the respective i-f transformers as shown in the layout diagram Figure 5. In later production, one trimmer is accessible from the top and the other from the bottom of each transformer.

BROADCAST BAND ALIGNMENT

1. Remove the signal generator lead from the 6SA7 grid and connect it to the radio antenna terminal through the .00025 mfd. capacitor. The ANT-LOOP switch (60) must be in the ANT. setting.
2. Check the tuning dial pointer adjustment. When the plates of the tuning condenser are completely meshed, the dial pointer must be in line with the last calibration mark at the low frequency end of the dial. If it is not, loosen the set screws in the hub of pulley "D" shown on Figure 1 and make the necessary adjustment.
3. With the band selector still set for broadcast band reception, adjust the signal generator and the radio receiver to 600 kc. While rocking the gang condenser a few degrees to the right and to the left, adjust the 600 kc. oscillator padder for maximum indication on the output meter.

4. Set the signal generator and the radio receiver to 1400 kc.; adjust the 1400 kc. oscillator trimmer and the 1400 kc. antenna trimmer for maximum output. If considerable adjustment was necessary, recheck the 600 kc. padder setting.

5. If the loop antenna trimmer is out of adjustment it should be set after the radio chassis is in the cabinet. Set the ANT-LOOP switch (60) to the LOOP position. Adjust the signal generator to 1400 kilocycles and connect its output to a loop containing approximately five turns of wire eight inches in diameter placed eighteen inches from the receiver loop and in the same plane.

6. Set the receiver to 1400 kc. and adjust the trimmer on the receiver loop for maximum output.

SHORT WAVE BAND ALIGNMENT

1. Set the band selector switch to SW as for short wave reception and substitute a 400 ohm resistor for the capacitor in series with the signal generator lead connected to the antenna terminal on the receiver.
2. Set the signal generator and the radio receiver to 15 mc.; then adjust the 15 mc. oscillator trimmer and the 15 mc. antenna trimmer for maximum output. While adjusting the 15 mc. oscillator trimmer two peaks may be observed; only one is the correct peak for 15 mc. alignment. Screw in the trimmer to maximum capacity—then decrease the capacity until the first peak is observed. This is the correct one.

10 KC FILTER ADJUSTMENT

This chassis incorporates a 10 kc. filter circuit to eliminate the beat note heard as a whistle between stations on the broadcast band. If the trimmer is out of adjustment, the following procedure should be observed.

1. Turn the Treble Control to FULL RANGE (No. 4 position).
2. Connect the output of an audio oscillator to the phonograph pickup socket on the radio chassis and adjust the oscillator to EXACTLY 10,000 cycles.
3. Set the band selector to PHONO and adjust the 10 kc. trimmer (8) for minimum output.
4. If an audio oscillator is not available for making this adjustment, set the band selector to BDCST, connect an antenna to the receiver and set the gang condenser to a point between two stations on adjacent channels having approximately the same power. If the 10 kc. trimmer is out of adjustment, a whistle will be heard. Adjust the trimmer until the whistle is eliminated.

SPECIAL SERVICE INFORMATION

The following information is provided for the service man who has a vacuum tube voltmeter or a similar measuring instrument available.

STAGE GAINS*

Antenna Post to R-F Grid at:	
600 kc.	7.0
6 mc.	1.63
R-F to Converter Grid at:	
600 kc.	3.4
6 mc.	3.4
R-F on Converter Grid to I-F Grid at:	
600 kc.	40.0
6 mc.	35.5

I-F on Converter Grid to . F Grid at:	
455 kc.	59
I-F Grid to Detector-Plate at:	
455 kc.	68

AUDIO GAIN

Voltage required across Volume Control to produce .05 watt speaker output** at 400 cycles is .014 volt with Band Selector Switch in BDCST setting.

OSCILLATOR OUTPUT VOLTAGE

The DC voltage developed across Oscillator Grid Resistor (40) at:	
600 kc.	5.8
6 mc.	6.6

* Variations of $\pm 20\%$ are permissible. All readings made with sufficient input signal to provide .05 watt speaker output.
 ** .05 watt speaker output at 400 cycles is equivalent to a reading of 0.35 volts as measured by a high resistance AC voltmeter across the voice coil of either speaker.

DIAL CORD REPLACEMENT

Rotate the brass pulley designated "A" in Figure 1 until the dial pointer strikes the stop at the high frequency end of the dial calibration. In this condition the slot in pulley "A" should be approximately ten degrees to the left of being vertical—see Figure 1. If the slot in the pulley is in some other position under the above mentioned conditions, the pointer set

screw is probably loose and has allowed the pointer to slip.

To correct this condition, first remove the glass dial and loosen the pointer screw. Then while holding pulley "A" so that its slot is approximately ten degrees to the left of vertical (when viewed from the rear) adjust the pointer until it is resting against the

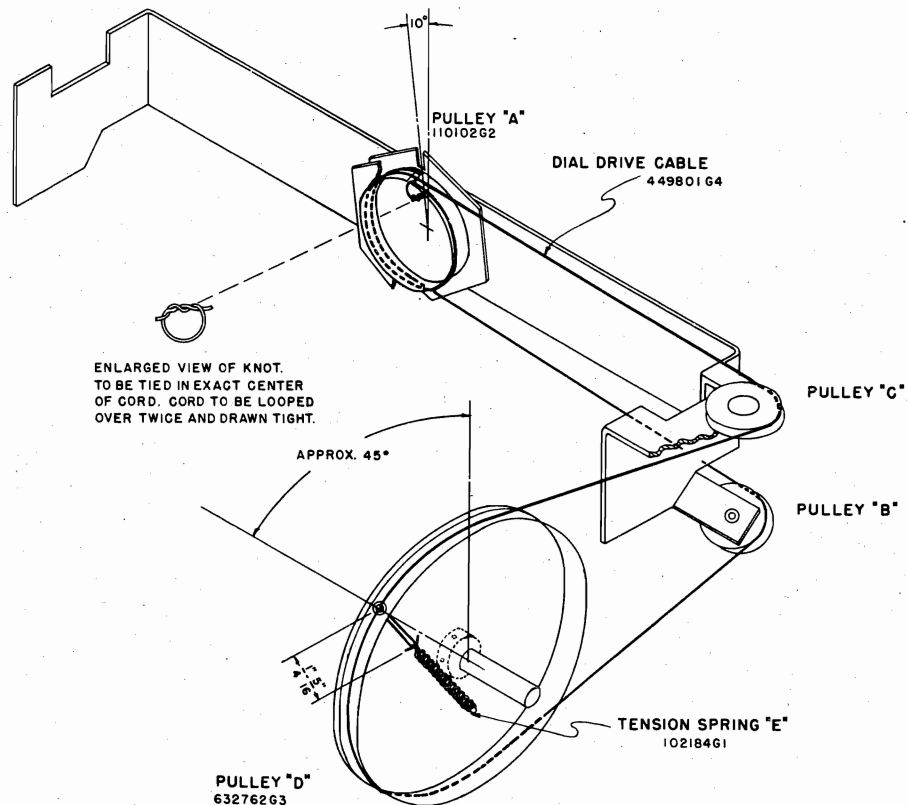

FIGURE 1

CHASSIS CR-188

stop at the high frequency end of its travel. Then tighten the pointer set screw securely and replace the glass dial.

Completely unmesh the condenser gang and check the location of the hole or slot in pulley "D." If this hole is not approximately 45 degrees back from vertical as shown on Figure 1, loosen the two No. 6 Allen set screws in the hub of pulley "D" and slip the pulley on its shaft (while holding the condenser gang unmeshed) until the specified adjustment is obtained; then tighten one of the set screws securely. It will be shown later that this is a temporary setting. Next, tie a double knot in the exact center of a 25-inch length of dial cable and fold the cable back on itself so that the knot is at one end. The correct method for tying this knot is shown as an inset on Figure 1. Grasp the cable near the knotted end and slide it into the pulley slot so that the knot is against the inside rim of the pulley as shown in the sketch. The piece of cable nearest the dial frame should be wound in the direction shown for one-half turn; then over the lower pulley "B," around the bottom of the large pulley "D" and into the hole. Pull the cable

taut and wrap the end around the small hook on pulley "D" temporarily.

The remaining piece of cable should be wound around pulley "A" in the direction shown, for one complete turn, over the upper pulley "C" and over the top of pulley "D." Thread the end through the small hole in pulley "D" and pull both ends of the cable taut. With one end of tension spring "E" fastened to the hook on pulley "D" lace the two free ends of the cable through the opposite end of the spring and tie a knot at a point that will allow $\frac{1}{4}$ " to $\frac{5}{16}$ " of cable between the spring and the inside rim of pulley "D." Be sure to tie the knot around one coil of the spring in the manner shown.

Now with the condenser gang completely meshed, check the position of the dial pointer. If it is not in line with the last calibration mark at the low frequency end of the dial, loosen the set screw in pulley "D" and turn it until the pointer is in the specified position. Be sure that the condenser gang does not move during this adjustment. Then tighten the two screws in pulley "D" securely completing the operation.

CONDENSER GANG DRIVE ADJUSTMENTS

Whenever any of the mechanical parts in the condenser gang drive assembly require replacement due to rough handling or for any other reason, it is extremely important that clearances and adjustments shown on Figures 2 and 3 are effected; otherwise the tuning mechanism will be sluggish or it may slip during operation.

In reassembling the mechanism after any part was replaced, follow the procedure outlined below:

1. Assemble the Tuning Shaft, Drive Collar, Compression Spring, Spring Retainer and Flywheel in the manner shown on Figure 3. Note that the Tuning Shaft must extend $\frac{3}{4}$ " from the front of the assembly and that the spacing between the rear of the Drive Collar and the front of the Flywheel must be $3\text{-}\frac{5}{64}$ ". Any excess length in the Tuning Shaft may extend beyond the rear of the Flywheel. See Figure 2.

2. The distance between the rubber-tired Drive Wheel and the smaller diameter section of the Spring Retainer must be $\frac{1}{32}$ " to $\frac{1}{16}$ " (Figure 3). This adjustment is effected by loosening the two No. 6 Allen set screws in the Drive Wheel hub and sliding the wheel on its shaft until the required clearance is obtained. When the adjustment is completed, tighten the two screws in the hub of the Drive Wheel.

sure of the front surface of the Drive Collar, when the Tuning Shaft is pulled out. The function of this switch is to open the muting circuit when setting up the push buttons. As its contacts are wired in series with the large muting switch (contacts are shorted by pressing any push button), pulling out on the Tuning Shaft causes the small switch contacts to open the muting circuit so that a station can be heard while the push button is held in and tightened. On rare occasions it may be necessary to adjust the

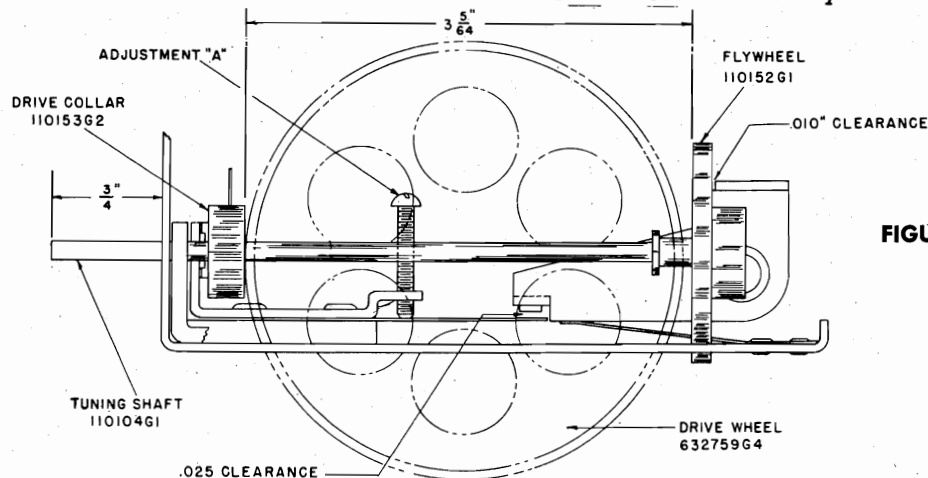

FIGURE 2

3. While pressing down on the Treadle Bar at the location shown on Figure 3, adjust the Thrust Bracket until the clearance between the rear of the Flywheel and the projection on the Thrust Bracket is .010" as shown on the diagram. To make this adjustment, loosen the two No. 6 Allen set screws (use No. 6 Allen Wrench—Magnavox Part No. 800044G2) in the hub of Thrust Bracket and rotate the bracket until the specified clearance is obtained when the push buttons are NOT actuated. Tighten the two screws securely when the adjustment is completed. Press each push button and check that the Drive Collar is pushed away from the rubber-tired Drive Wheel.

4. Next, adjust the clearance in the muting switch contacts by turning the Phillips-head screw designated Adjustment "A" on Figure 2, until the specified clearance of .025" is obtained (when the push but-

tons are NOT actuated.)

5. While pressing any one of the push buttons in as far as possible, turn the screw designated Adjustment "B" until a minimum clearance of .015" is obtained between the front surface of the Drive Collar and the switch spring directly in front of it. This setting should also cause a minimum clearance of .010" between the switch contacts actuated by pre-rotation between the push button bars and the Treadle Bar. Such adjustment might be required if when pushing any of the push buttons, sufficient motion is not transmitted to the Treadle Bar to cause a disengagement between the Drive Collar and the Drive wheel.

This can usually be accomplished by loosening the two screws designated "C" and "D" on Figure 3, and moving plate "B" in the direction required to correct this condition.

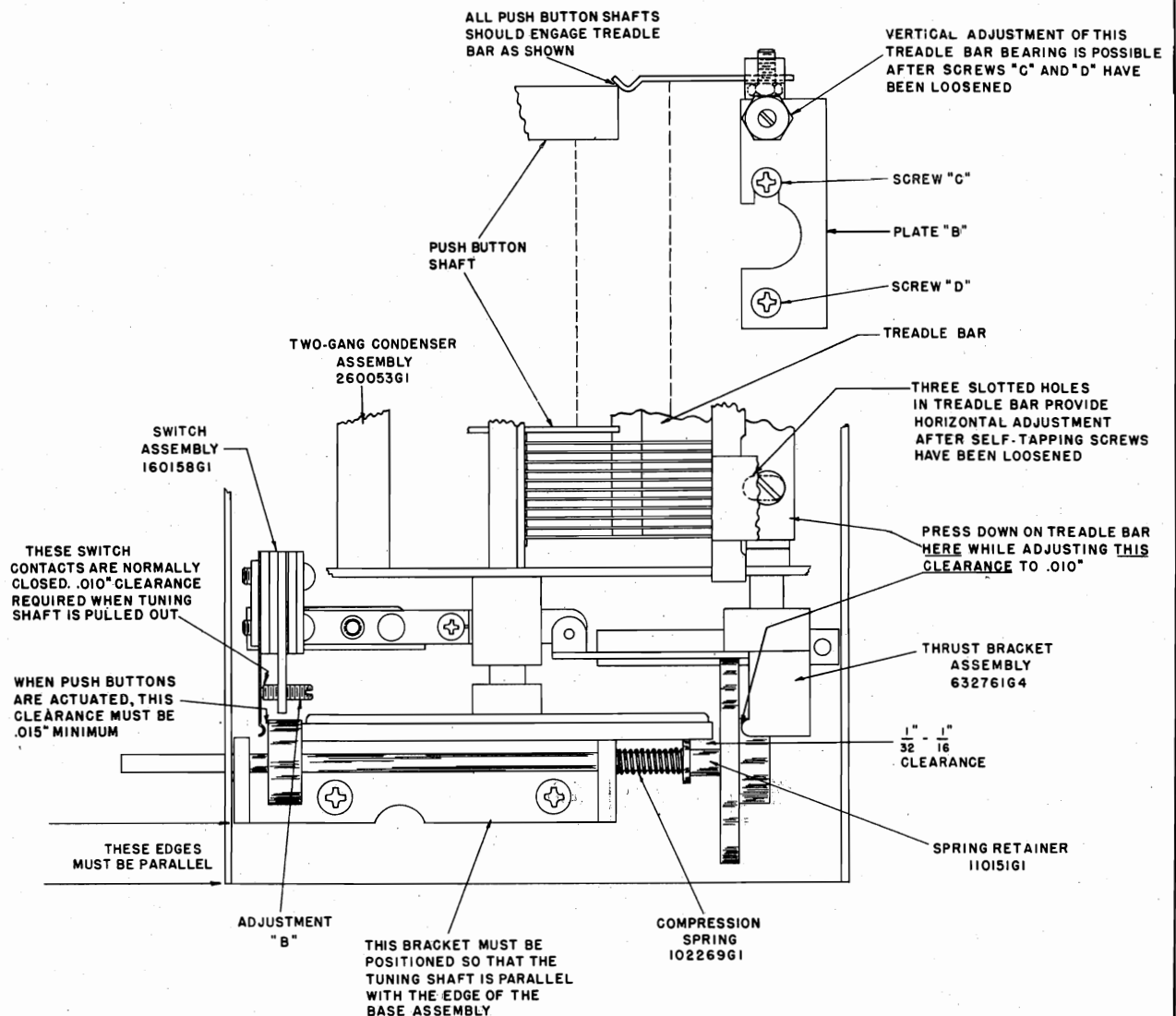

FIGURE 3

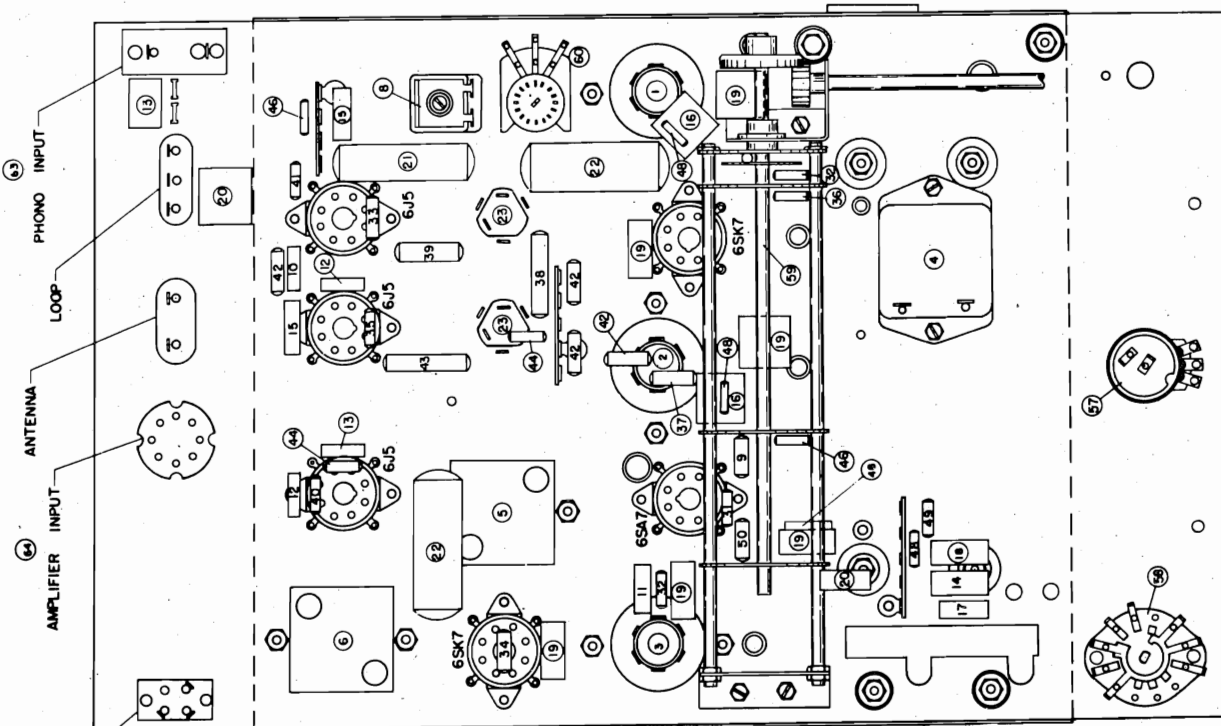
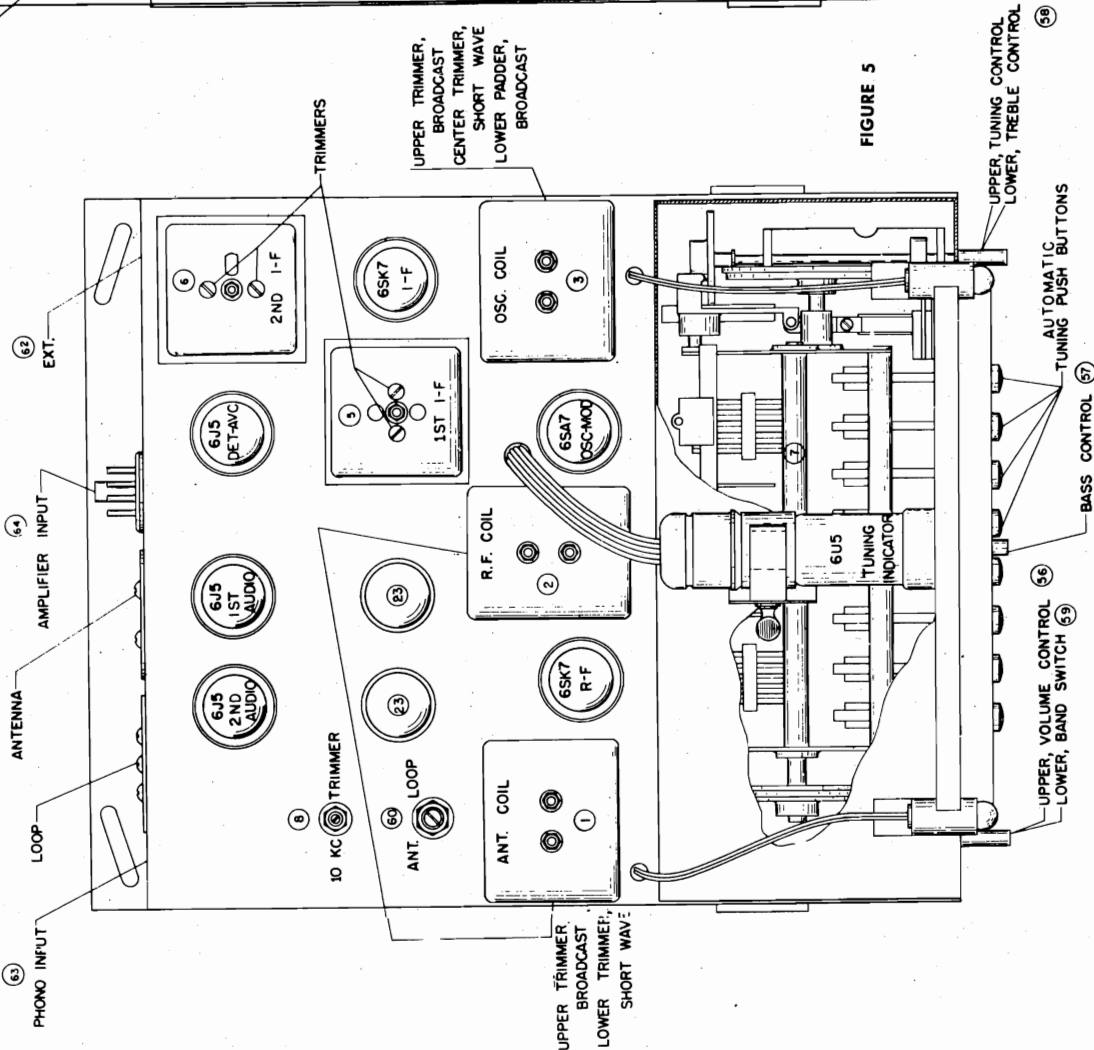
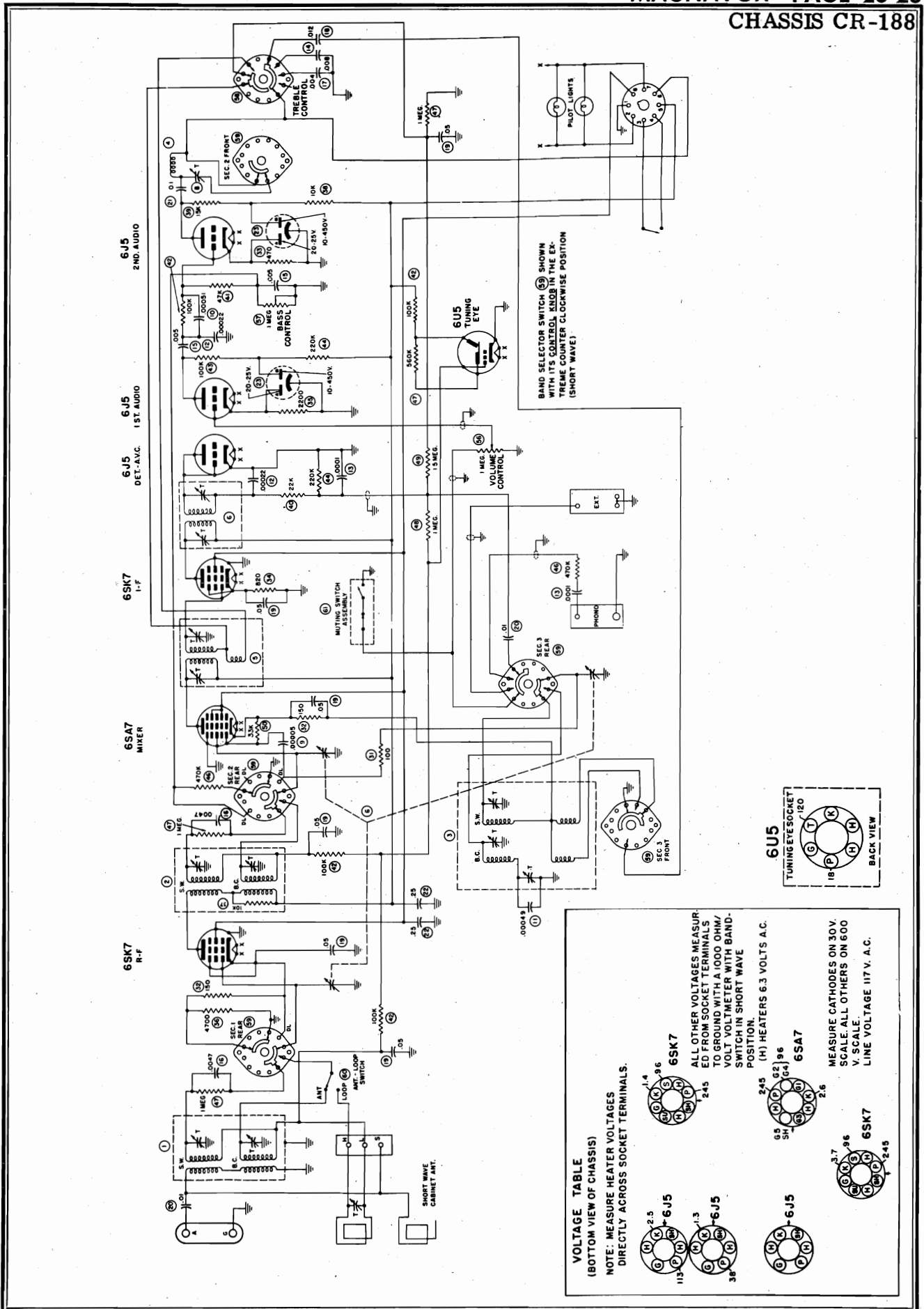

FIGURE 5





VOLTAGE TABLE
(BOTTOM VIEW OF CHASSIS)

NOTE: MEASURE HEATER VOLTAGES DIRECTLY ACROSS SOCKET TERMINALS.

6J5

6SK7

6SA7

6U5

ALL OTHER VOLTAGES MEASURED FROM SOCKET TERMINALS TO GROUND WITH A 1000 OHM/VOLT VOLT-METER WITH BAND-SWITCH IN SHORT WAVE POSITION.

(H) HEATERS 6.3 VOLTS A.C.

MEASURE CATHODES ON 30V. SCALE. ALL OTHERS ON 600 V. SCALE.

LINE VOLTAGE 117 V. A.C.

CHASSIS CR-188

PARTS LIST

REFERENCE NO.	DESCRIPTION	MAGNAVOX PART NO.
1	Coil Assembly, antenna, two band	360254G1
2	Coil Assembly, r-f, two band	360254G2
3	Coil Assembly, oscillator, two band	360253G1
4	Coil Assembly, 10 kc. filter	360244G1
5	Transformer, first i-f.	360266G1
6	Transformer, second i-f.	360267G1
7	Capacitor, variable, three-gang tuning	260054G1
8	Capacitor, variable, 10 kc. trimmer	259610G1
9	Capacitor, ceramic, 50 mmf.	250088G25
10	Capacitor, molded mica, 510 mmf.	250159G64
11	Capacitor, silvered mica, 490 mmf. $\pm 1\%$	250085G32
12	Capacitor, molded mica, 220 mmf.	250159G100
13	Capacitor, molded mica, 100 mmf.	250159G98
14	Capacitor, paper, 008 mfd.	250129G11
15	Capacitor, paper, .005 mfd.	250129G10
16	Capacitor, molded mica, .0047 mfd.	250161G5
17	Capacitor, paper, .004 mfd.	250129G7
18	Capacitor, paper, .012 mfd.	250129G13
19	Capacitor, paper, .05 mfd.	250129G5
20	Capacitor, paper, .01 mfd.	250129G9
21	Capacitor, paper, 0.1 mfd.	250152G22
22	Capacitor, paper, 0.25 mfd.	250152G21
23	Capacitor, electrolytic, 20 mfd. 25V—10 mfd. 450V.	270023G6
31	Resistor, composition, 100 ohm $\frac{1}{2}$ W.	230084G7
32	Resistor, composition, 150 ohm $\frac{1}{2}$ W.	230084G8
33	Resistor, composition, 470 ohm $\frac{1}{2}$ W.	230084G11
34	Resistor, composition, 820 ohm $\frac{1}{2}$ W.	230084G61
35	Resistor, composition, 2200 ohm $\frac{1}{2}$ W.	230084G15
36	Resistor, composition, 4700 ohm $\frac{1}{2}$ W.	230084G17
37	Resistor, composition, 10,000 ohm $\frac{1}{2}$ W.	230084G19
38	Resistor, composition, 10,000 ohm 1 W.	230085G19
39	Resistor, composition, 15,000 ohm 1 W.	230085G20
40	Resistor, composition, 22,000 ohm $\frac{1}{2}$ W.	230084G21
41	Resistor, composition, 47,000 ohm $\frac{1}{2}$ W.	230084G23
42	Resistor, composition, 100,000 ohm $\frac{1}{2}$ W.	230084G25
43	Resistor, composition, 100,000 ohm 1 W.	230085G25
44	Resistor, composition, 220,000 ohm $\frac{1}{2}$ W.	230084G27
46	Resistor, composition, 470,000 ohm $\frac{1}{2}$ W.	230084G29
47	Resistor, composition, 560,000 ohm $\frac{1}{2}$ W.	230084G95
48	Resistor, composition, 1 megohm $\frac{1}{2}$ W.	230084G31
49	Resistor, composition, 1.5 megohm $\frac{1}{2}$ W.	230084G32
50	Resistor, composition, 33,000 ohm $\frac{1}{2}$ W.	230084G22
56	Control, volume, 1 megohm	220044G15
57	Control, bass, 1 megohm with switch	220045G2
58	Switch, rotary, treble control	160161G1
59	Switch, rotary, band selector	160160G1
60	Switch, rotary, loop to outdoor antenna	160157G1
61	Switch assembly, muting	160158G2
62	Socket, external input	180060G1
63	Socket, phonograph input	189741G1
64	Plug, octal, amplifier connection	180511G14
	Antenna, loop assembly	*
	Dial glass assembly	150285

*The part number of the loop antenna assembly changes with different cabinets. It is therefore important that you specify the *Style Number* of the instrument when ordering a replacement loop antenna assembly.

SPECIFICATIONS

Power supply.....	117 volts 50/60 cycles AC	
Power consumption.....	150 watts	
Power output.....	20 watts	
Intermediate frequency.....	455 kc.	
Tuning frequency range:		
Broadcast band.....	520-1620 kc.	
Short Wave band.....	5.0-18.2 mc.	
Tubes:		
Converter	6SA7	
I-F Amplifier	6SK7	
Detector and AVC.....	6J5	
First Audio	6J5	
Inverter	6SN7GT	
Power output (push-pull stage).....	(2) 6L6G	
Rectifier	5U4G	
Tuning Indicator.....	6U5	
Dial lamps.....	Mazda No. 51	
Speakers:	No. 582815	No. 582847
Field coil resistance.....	250 ohms	250 ohms
Voice coil impedance (400 cycles).....	5.7 ohms	5.4 ohms
Output transformer.....	None	5,000/3 ohms

Method for Removing Chassis from Cabinet

Model CR-193 radio chassis is designed for easy removal from the cabinet in which it is installed. As the radio panel is permanently fastened to the chassis, the control knobs need not be removed when the chassis is taken out of the cabinet for service.

To remove the chassis, first remove the antenna leads from their terminals and all plugs from the receptacles on the rear of the chassis. Then remove the two Phillips-head screws from the angular slots in the flange at the rear of the chassis. Lift the rear of the chassis about one inch and pull it straight back. Never remove the chassis tray from the cabinet—it has been properly positioned to bring the radio panel in place when the chassis is replaced. In replacing the chassis, slide it so that the small hooks near the front, ride inside the flanges on the

sides of the chassis tray. Push the chassis forward as far as it will go and the hook should then engage the slots in the chassis tray. Replace the two Phillips-head screws and nuts and tighten securely. Replace all plugs in their receptacles and the antenna leads on their correct terminals. The antenna terminal board for the loop antenna connections is designated S-L-H. The end of the short wave antenna that is fastened to the inside of the cabinet connects to S. Always disconnect this antenna from terminal S when an outdoor antenna is used as it may pick up noise. The two terminals on the loop are designated L and H. The leads connected to these terminals should be wired to the corresponding terminals (L and H) on the chassis.

ALIGNMENT PROCEDURE

I-F ALIGNMENT

The alignment of this receiver requires the use of an accurately calibrated r-f signal generator and an output meter. All trimmer condenser locations are shown on the chassis layout diagram, Figure 5. The radio volume control should be turned to maximum and the signal generator output kept as low as possible during alignment to prevent the AVC from operating and giving false readings. *Always set the Selectivity Switch to SHARP TUNE before aligning the i-f stages.* This is done by turning the Treble Control counter-clockwise as far as possible.

1. Connect the output of the signal generator to the oscillator grid (pin No. 5) of the 6SA7 tube through a .00025 mfd. capacitor. The ground on the signal generator should be connected to the radio chassis ground.

2. Turn the condenser gang until it is completely meshed, (low-frequency end of dial calibration) and set the band selector switch to BDCST as for broadcast band reception.

CHASSIS CR-193

3. Adjust the signal generator to EXACTLY 455 kc. and peak the second i-f transformer and the first i-f transformer trimmers in that order.

On early models of the CR-193 chassis, the two i-f trimmers are located in the top of the respective i-f transformers. In later production, one trimmer is accessible from the top and the other from the bottom of each transformer as shown in the layout diagram, Figure 5.

BROADCAST BAND ALIGNMENT

1. Remove the signal generator lead from the 6SA7 grid and connect it to the radio antenna terminal through the .00025 mfd. capacitor. The ANT-LOOP switch (70) must be in the ANT. setting.
2. Check the tuning dial pointer adjustment. When the plates of the tuning condenser are completely meshed, the dial pointer must be in line with the last calibration mark at the low frequency end of the dial. If it is not, loosen the set screws in the hub of pulley "D" shown on Figure 1 and make the necessary adjustment.
3. With the band selector still set for broadcast band reception, adjust the signal generator and the radio receiver to 600 kc. While rocking the gang condenser a few degrees to the right and to the left, adjust the 600 kc. oscillator padder for maximum indication on the output meter.
4. Set the signal generator and the radio receiver to 1400 kc., adjust the 1400 kc. oscillator trimmer and the 1400 kc. antenna trimmer for maximum output. If considerable adjustment was necessary, recheck the 600 kc. padder setting.
5. If the loop antenna trimmer is out of adjustment it should be set after the radio chassis is in the cabinet. Set the ANT-LOOP switch (70) to the LOOP position. Adjust the signal generator to 1400 kilocycles and connect its output to a loop containing approximately five turns of wire eight inches in diameter placed eighteen inches from the receiver loop and in the same plane.
6. Set the receiver to 1400 kc. and adjust the trimmer on the receiver loop for maximum output.

SHORT WAVE BAND ALIGNMENT

1. Set the band selector switch to SW as for short wave reception and substitute a 400 ohm resistor for the capacitor in series with the signal generator lead connected to the antenna terminal on the receiver.
2. Set the signal generator and the radio receiver to 15 mc.; then adjust the 15 mc. oscillator trimmer and the 15 mc. antenna trimmer for maximum output. While adjusting the 15 mc. oscillator trimmer two peaks may be observed; only one is the correct peak

for 15 mc. alignment. Screw in the trimmer to maximum capacity—then decrease the capacity until the first peak is observed. This is the correct one.

10 KC FILTER ADJUSTMENT

This chassis incorporates a 10 kc. filter circuit to eliminate the beat note heard as a whistle between stations on the broadcast band. If the trimmer is out of adjustment, the following procedure should be observed.

1. Set the Selectivity Switch to FULL RANGE by turning the Treble Control knob clockwise as far as possible.
2. Connect the output of an audio oscillator to the phonograph pickup socket on the radio chassis and adjust the oscillator to EXACTLY 10,000 cycles.
3. Set the band selector to PHONO and adjust the 10 kc. trimmer (7) for minimum output.
4. If an audio oscillator is not available for making this adjustment, set the band selector to BDCST, connect an antenna to the receiver and set the gang condenser to a point between two stations on adjacent channels having approximately the same power. If the 10 kc. trimmer is out of adjustment, a whistle will be heard. Adjust the trimmer until the whistle is eliminated.

SPECIAL SERVICE INFORMATION

The following information is provided for the service man who has a vacuum tube voltmeter or a similar measuring instrument available.

STAGE GAINS*

Antenna Post to Converter Grid at:	
600 kc.	5.5
6 mc.	2.0
R-F on Converter to I-F Grid at:	
600 kc.	28
6 mc.	22
I-F on Converter Grid to I-F Grid at:	
455 kc.	34
I-F Grid to Detector Plate at:	
455 kc.	67

AUDIO GAIN

Voltage required across Volume Control to produce .05 watt speaker output** at 400 cycles is .010 volt with Band Selector Switch in BDCST setting.

OSCILLATOR OUTPUT VOLTAGE

The DC voltage developed across Oscillator Grid Resistor (48) at:	
600 kc.	5.6
6 mc.	6.0

* Variations of ±20% are permissible. All readings made with sufficient input signal to provide .05 watt speaker output.
 ** .05 watt speaker output at 400 cycles is equivalent to a reading of 0.4 volts as measured by a high resistance AC voltmeter across the voice coil of either speaker.

DIAL CORD REPLACEMENT

Rotate the brass pulley designated "A" in Figure 1 until the dial pointer strikes the stop at the high frequency end of the dial calibration. In this condition the slot in pulley "A" should be approximately ten degrees to the left of being vertical—see Figure 1. If the slot in the pulley is in some other position under the above mentioned conditions, the pointer set screw is probably loose and has allowed the pointer to slip.

To correct this condition, first remove the glass dial and loosen the pointer screw. Then while holding pulley "A" so that its slot is approximately ten degrees to the left of vertical (when viewed from the rear) adjust the pointer until it is resting against the stop at the high frequency end of its travel. Then tighten the pointer set screw securely and replace the glass dial.

Completely unmesh the condenser gang and check the location of the hole or slot in pulley "D." If this hole is not approximately 45 degrees back from vertical as shown on Figure 1, loosen the two No. 6 Allen set screws in the hub of pulley "D" and slip the pulley on its shaft (while holding the condenser gang unmeshed) until the specified adjustment is obtained; then tighten one of the set screws securely. It will be shown later that this is a temporary setting. Next, tie a double knot in the exact center of a 25-inch length of dial cable and fold the cable back on itself so that the knot is at one end. The correct method for tying this knot is shown as an inset on

Figure 1. Grasp the cable near the knotted end and slide it into the pulley slot so that the knot is against the inside rim of the pulley as shown in the sketch. The piece of cable nearest the dial frame should be wound in the direction shown for one-half turn; then over the lower pulley "B," around the bottom of the large pulley "D" and into the hole. Pull the cable taut and wrap the end around the small hook on pulley "D" temporarily.

The remaining piece of cable should be wound around pulley "A" in the direction shown, for one complete turn, over the upper pulley "C," and over the top of pulley "D." Thread the end through the small hole in pulley "D" and pull both ends of the cable taut. With one end of tension spring "E" fastened to the hook on pulley "D" lace the two free ends of the cable through the opposite end of the spring and tie a knot at a point that will allow $\frac{1}{4}$ " to $\frac{5}{16}$ " of cable between the spring and the inside rim of pulley "D." Be sure to tie the knot around one coil of the spring in the manner shown.

Now with the condenser gang completely meshed, check the position of the dial pointer. If it is not in line with the last calibration mark at the low frequency end of the dial, loosen the set screw in pulley "D" and turn it until the pointer is in the specified position. Be sure that the condenser gang does not move during this adjustment. Then tighten the two screws in pulley "D" securely completing the operation.

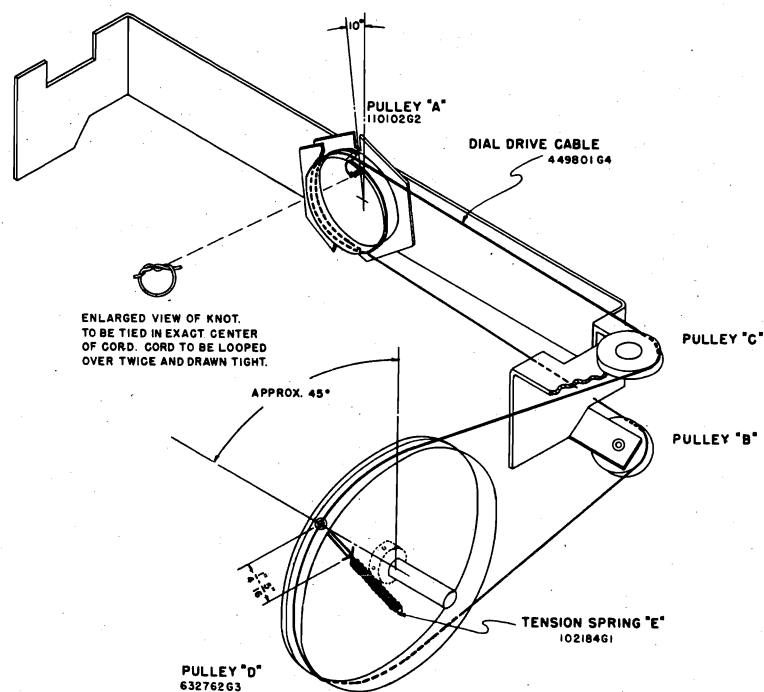

FIGURE 1

CONDENSER GANG DRIVE ADJUSTMENTS

Whenever any of the mechanical parts in the condenser gang drive assembly require replacement due to rough handling or for any other reason, it is extremely important that clearances and adjustments shown on Figures 2 and 3 are affected; otherwise the tuning mechanism will be sluggish or it may slip during operation.

In reassembling the mechanism after any part was replaced, follow the procedure outlined below:

1. Assemble the Tuning Shaft, Drive Collar, Compression Spring, Spring Retainer and Flywheel in the manner shown on Figure 3. The Tuning Shaft must extend $\frac{3}{4}$ " from the front of the assembly and that the spacing between the rear of the Drive Collar and the front of the Flywheel must be $3\frac{5}{64}$ " as specified on Figure 2. Any excess length in the Tuning Shaft may extend beyond the rear of the Flywheel.

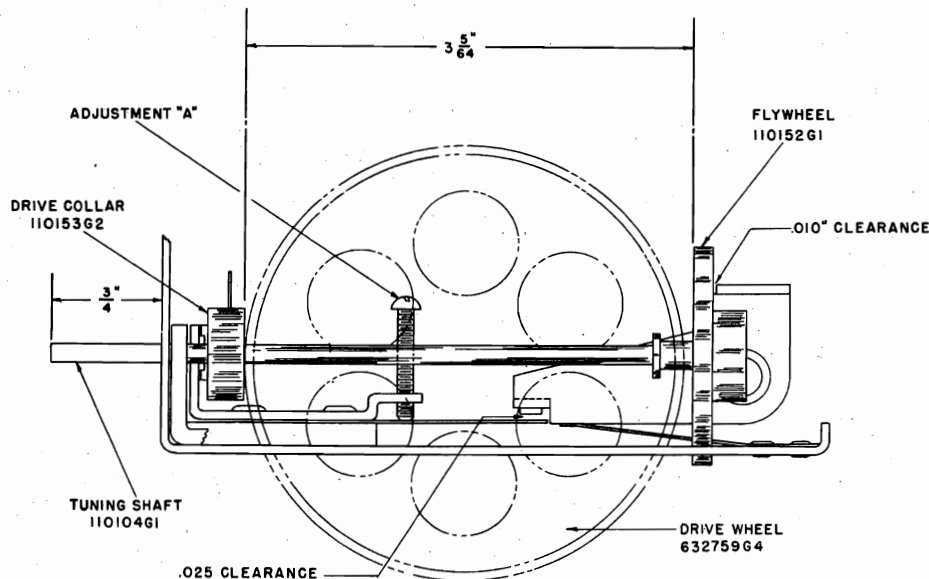

FIGURE 2

2. The distance between the rubber-tired Drive Wheel and the smaller diameter section of the Spring Retainer must be $\frac{1}{32}$ " to $\frac{1}{16}$ ". This adjustment is effected by loosening the two No. 6 Allen set screws in the Drive Wheel hub and sliding the wheel on its shaft until the required clearance is obtained. When the adjustment is completed, tighten the two screws in the hub of the Drive Wheel. See Figure 3.

3. While pressing down on the Treadle Bar at the location shown on Figure 3, adjust the Thrust Bracket until the clearance between the rear of the Flywheel and the projection on the Thrust Bracket is $.010$ " as shown on the diagram. To make this adjustment, loosen the two No. 6 Allen set screws (use No. 6 Allen Wrench—Magnavox Part No. 800044G2) in the hub of Thrust Bracket and rotate the bracket until the specified clearance is obtained when the push buttons are NOT actuated. Tighten the two screws securely when the adjustment is completed. Press each push button and check that the Drive Collar is pushed away from the rubber-tired Drive Wheel.

4. Next, adjust the clearance in the muting switch contacts by turning the Phillips-head screw designated Adjustment "A" on Figure 2, until the specified clearance of $.025$ " is obtained (when the push but-

tons are NOT actuated.)

5. While pressing any one of the push buttons in as far as possible, turn the screw designated Adjustment "B" (Figure 3) until a minimum clearance of $.015$ " is obtained between the front surface of the Drive Collar and the switch spring directly in front of it. This setting should also cause a minimum clearance of $.010$ " between the switch contacts actuated

by pressure of the front surface of the Drive Collar, when the Tuning Shaft is pulled out. The function of this switch is to open the muting circuit when setting up the push buttons. As its contacts are wired in series with the large muting switch (contacts are shorted by pressing any push button), pulling out on the Tuning Shaft causes the small switch contacts to open the muting circuit so that a station can be heard while the push button is held in and tightened. On rare occasions it may be necessary to adjust the

relation between the push button bars and the Treadle Bar. Such adjustment might be required if when pushing any of the push buttons, sufficient motion is not transmitted to the Treadle Bar to cause a disengagement between the Drive Collar and the Drive wheel.

This can usually be accomplished by loosening the two screws designated "C" and "D" on Figure 3, and moving plate "B" in the direction required to correct this condition.

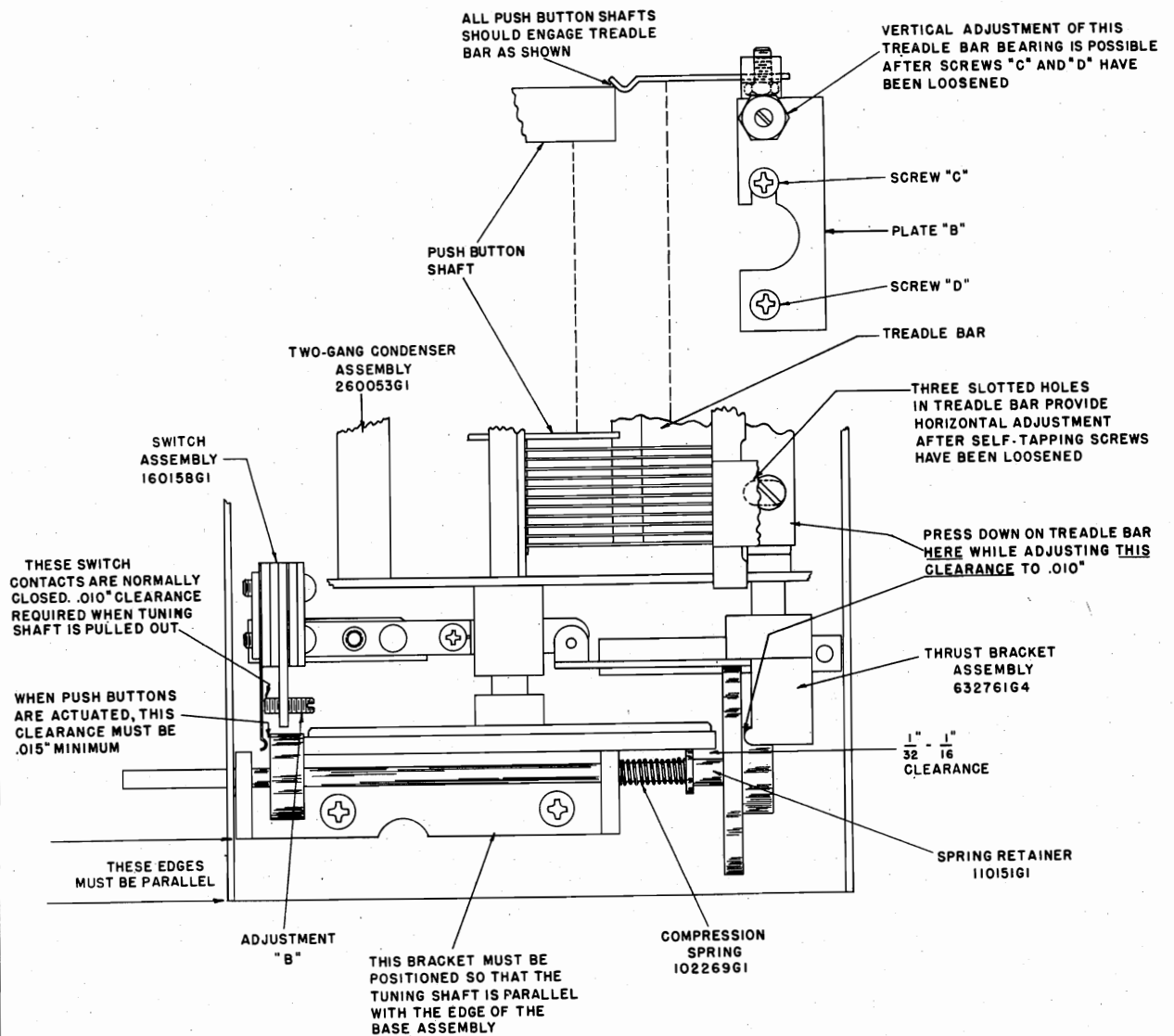

FIGURE 3

CHASSIS
CR-193

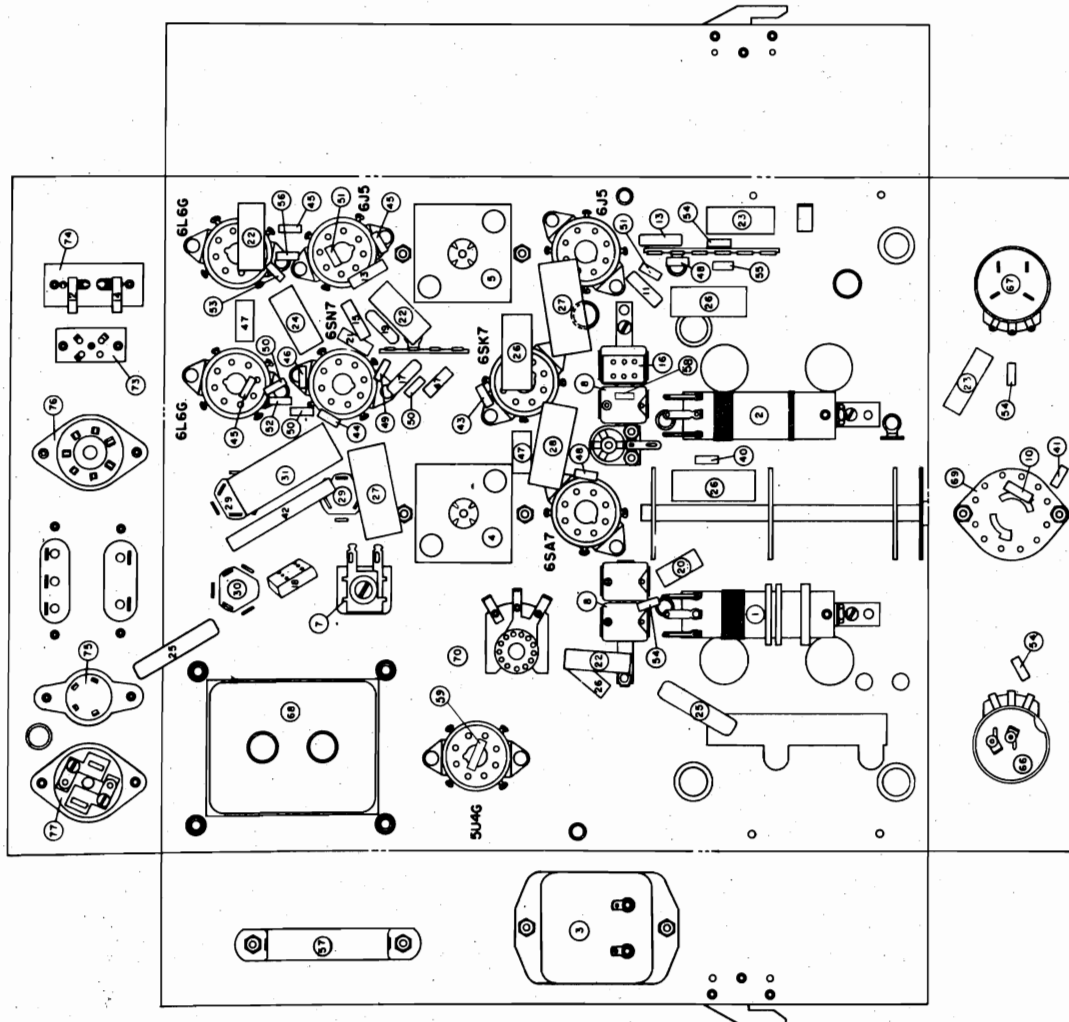
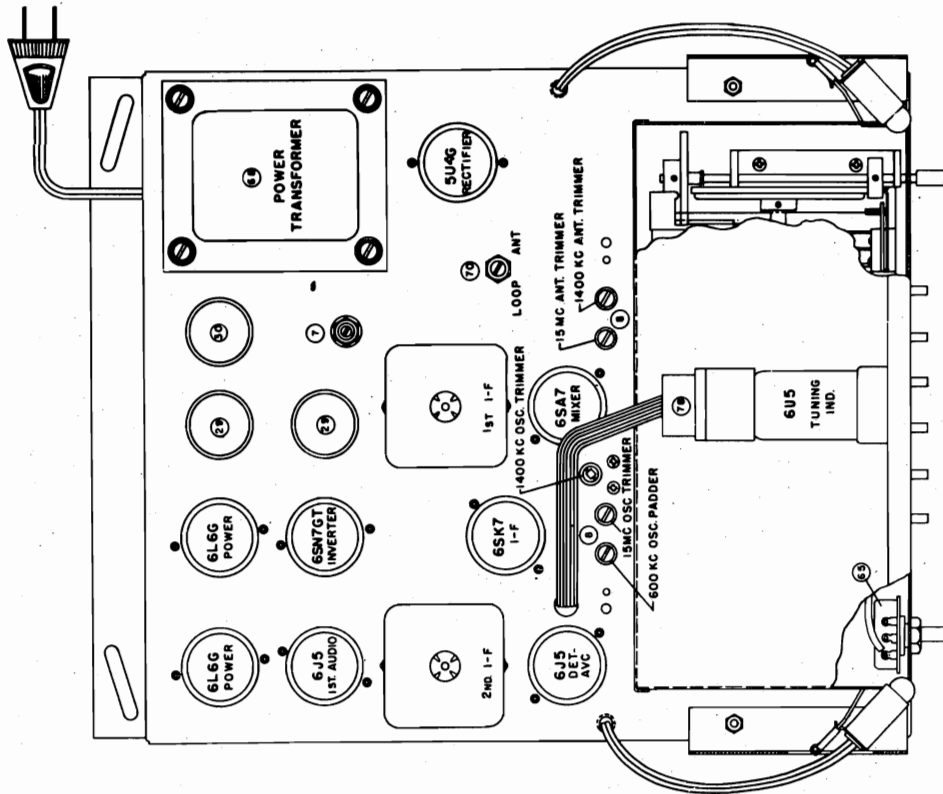
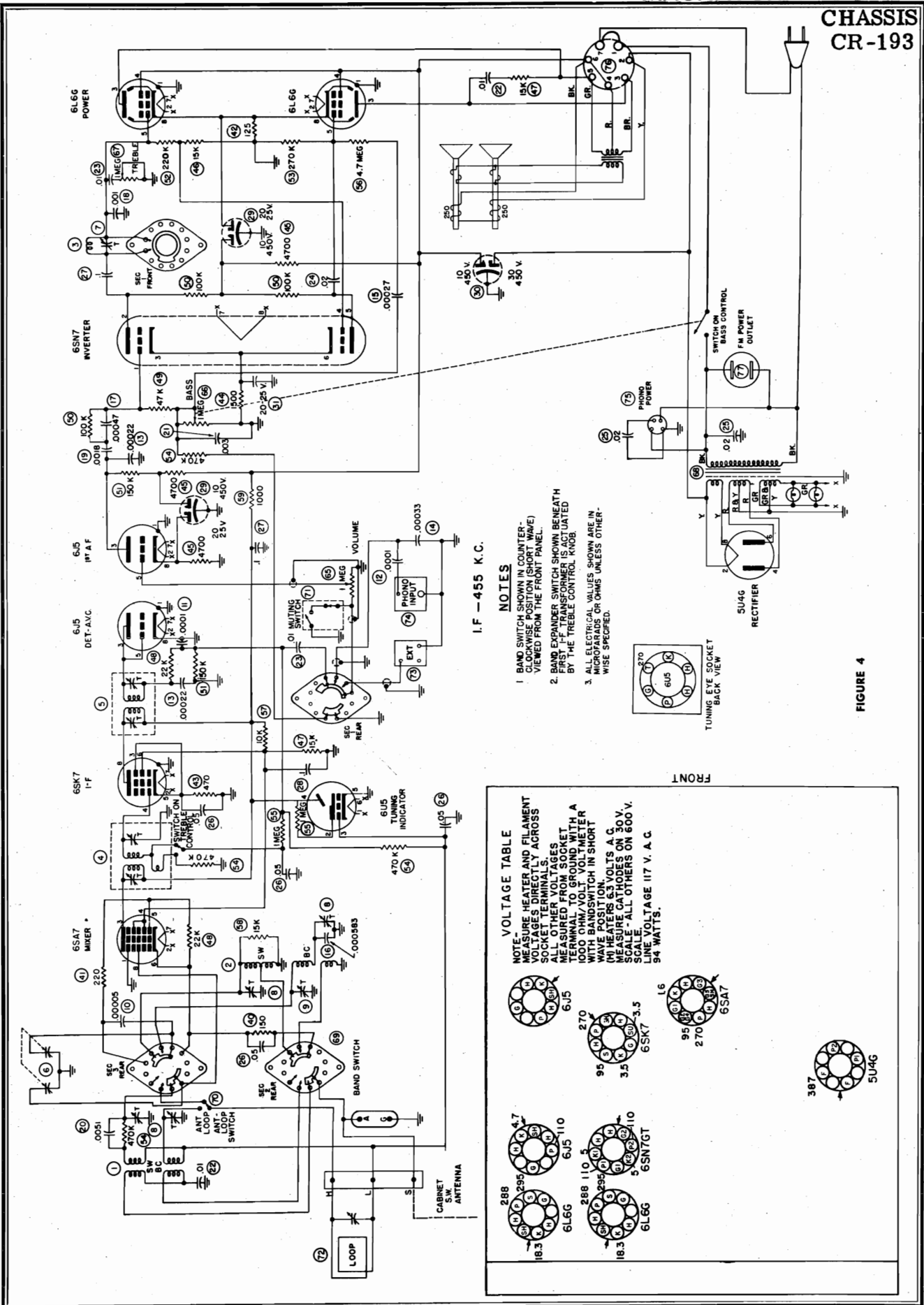

FIGURE 5



I.F. - 455 K.C.

NOTES

1. BAND SWITCH SHOWN IN COUNTER-POSITION. SEE POSITION (LEFT WAVE) VIEWED FROM THE FRONT PANEL.
2. BAND EXPANDER SWITCH SHOWN BENEATH POSITION. TRANSDUCER IS ACTUATED BY THE TREBLE CONTROL. NIBB.
3. ALL ELECTRICAL VALUES SHOWN ARE IN MICROPARADS OR OHMS UNLESS OTHERWISE SPECIFIED.

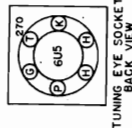

VOLTAGE TABLE
NOTE - HEATER AND FILAMENT VOLTAGES DIRECTLY ACROSS SOCKET TERMINALS.
ALL OTHER VOLTAGES MEASURED FROM SOCKET TERMINALS.
(M) MEASUREMENT WITH 1000 OHM VOLT METER WITH BANDSWITCH IN SHORT WAVE POSITION.
(H) HEATERS 6.3 VOLTS A.C.
MEASURE CATHODES ON 30V. SCALE - ALL OTHERS ON 600 V. LINE VOLTAGE 117 V. A.C. 94 WATTS.

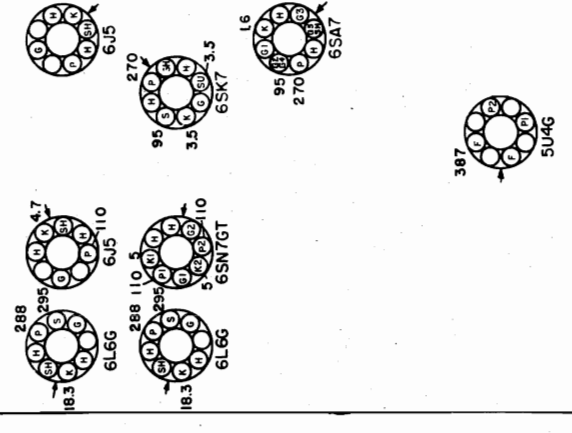

FIGURE 4

CHASSIS CR-193

PARTS LIST

REFERENCE NO.	DESCRIPTION	MAGNAVOX PART NO.	REFERENCE NO.	DESCRIPTION	MAGNAVOX PART NO.
1	Coil assembly, r-f, two band.	360238G1	41	Resistor, composition, 220 ohm 1/2 W.	230084G9
2	Coil assembly, oscillator, two band.	360239G1	42	Resistor, wire wound 125 ohm 10 W.	240021G11
3	Coil assembly, 10 kc filter.	360240G1	43	Resistor, composition, 470 ohm 1/2 W.	230084G1
4	Transformer, first i-f.	360266G1	44	Resistor, composition, 1500 ohm 1/2 W.	230084G14
5	Transformer, second i-f.	360267G1	45	Resistor, composition, 4700 ohm 1/2 W.	230084G17
6	Capacitor, variable, two-gang tuning.	260053G1	46	Resistor, composition, 15,000 ohm ±5% 1/2 W.	230084G187
7	Capacitor, variable, 10 kc trimmer.	250008G1	47	Resistor, composition, 15,000 ohm 1 W.	230085G20
8	Capacitor, variable, 2 gang trimmer.	260021G1	48	Resistor, composition, 22,000 ohm 1/2 W.	230084G21
9	Capacitor, variable, oscillator padder.	260042G2	49	Resistor, composition, 47,000 ohm 1/2 W.	230084G23
10	Capacitor, ceramic, 50 mmf.	250088G24	50	Resistor, composition, 100,000 ohm 1/2 W.	230084G25
11	Capacitor, molded mica, 100 mmf. ±20%.	250159G98	51	Resistor, composition, 150,000 ohm 1/2 W.	230084G26
12	Capacitor, molded mica, 100 mmf. ±10%.	250159G82	52	Resistor, composition, 220,000 ohm ±5% 1/2 W.	230084G215
13	Capacitor, molded mica, 220 mmf.	250159G100	53	Resistor, composition, 270,000 ohm 1/2 W.	230084G91
14	Capacitor, molded mica, 330 mmf.	250159G88	54	Resistor, composition, 470,000 ohm 1/2 W.	230084G29
15	Capacitor, molded mica, 270 mmf.	250159G87	55	Resistor, composition, 1 megohm 1/2 W.	230084G31
16	Capacitor, silvered mica, 583 mmf. ±1%.	250085G33	56	Resistor, composition, 4.7 megohm 1/2 W.	230084G35
17	Capacitor, molded mica, 470 mmf.	250159G102	57	Resistor, wire wound, 10,000 ohm.	240035G2
18	Capacitor, molded mica, 1000 mmf.	250160G82	58	Resistor, composition, 15,000 ohm 1/2 W.	230084G20
19	Capacitor, molded mica, 1800 mmf.	250160G67	59	Resistor, composition, 1000 ohm 2 W.	230064G62
20	Capacitor, molded mica, 5100 mmf. ±2%.	250161G6	65	Control, volume, 1 megohm.	220044G15
21	Capacitor, paper, .003 mfd. 400 V.	250152G43	66	Control, bass, 1 megohm, with power switch.	220045G2
22	Capacitor, paper, .01 mfd. 600 V.	250152G38	67	Control, treble, 1 megohm, with band expander switch.	220071G2
23	Capacitor, paper, .01 mfd. 200 V.	250152G18	68	Transformer, power, 117 V. 50/60 cycle.	300032G1
24	Capacitor, paper, .02 mfd. 400 V.	250152G26	69	Switch, rotary, band selector.	160156G1
25	Capacitor, molded paper, .02 mfd. 600 V.	250129G3	70	Switch, rotary, loop to outdoor antenna.	160157G1
26	Capacitor, paper, .05 mfd. 200 V.	250152G15	71	Switch assembly, muting.	160158G1
27	Capacitor, paper, .1 mfd. 400 V.	250152G22	72	Antenna, loop assembly.	*
28	Capacitor, paper, .1 mfd. 200 V.	250152G13	73	Socket, external input.	180060G1
29	Capacitor, electrolytic, 10 mfd. 450 V., 20 mfd. 25V.	270023G6	74	Socket, phonograph input.	189741G1
30	Capacitor, electrolytic, 10-30 mfd. 450 V.	270023G2	75	Socket, phonograph motor.	180501G5
31	Capacitor, electrolytic, 20 mfd. 25V.	270027G2	76	Socket, speaker.	180393G3
40	Resistor, composition, 150 ohm 1/2 W.	230084G8	77	Socket, FM power.	180422G1
			78	Socket & Cable assembly, tuning indicator.	180423G1
				Dial glass assembly.	150283G1

*The part number of the loop antenna assembly changes with different cabinets. It is therefore important that you specify the Style Number of the instrument when ordering a replacement loop antenna assembly.

Model 9030 Radio-Phonograph

GENERAL FEATURES

The Model 9030 is a combination designed for the reception of radio broadcast programs and reproduction of phonograph records, television or other external sound. The combination includes: (1) radio-phono chassis, (2) record changer, and (3) high fidelity loudspeaker.

TECHNICAL DATAPower Input

100 watts at 117 volts, 50-60 cycles. (Phono motor 60 cycles, 25 watts additional.)

Tube Complement

Seven including one rectifier: (1) 6BE6 osc. converter, (1) 6BA6 I.F. amplifier, (1) 6SQ7 detector 1st audio, (1) 6SN7 phase splitter, (2) 6V6 power amplifier, (1) 5Y3GT rectifier.

Tuning Range

AM - 540 - 1600 kc

Speaker

10 inch high fidelity PM type.

Controls

Five - station selector, function switch, on-off bass control, volume control, treble control.

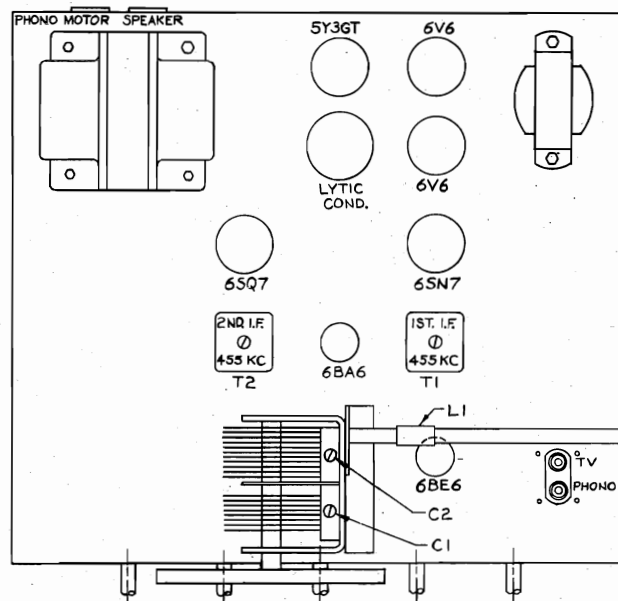
INSTALLATION

The Model 9030 Radio-Phonograph comes complete with all equipment installed and ready for operation after taking the following precautions:

1. Remove any packing material which may be used to hold the tubes in place.
2. Remove any tape or rubber bands which may be holding the pickup arm and accessories in place.
3. Insert the a.c. line plug into convenient electrical outlet.

MODEL 9030
Station Selector

OPERATION OF CONTROLS

The large center knob adjusts the receiver to the desired station. The dial pointer follows the rotation of the knob and indicates the frequency to which the receiver is tuned. Assigned frequencies of AM broadcast stations are on the radio page of your newspaper.

Volume Control

The knob directly to the left of the large station selector knob adjusts the volume of sound. Turn clockwise to increase volume and counter-clockwise to decrease volume. The control is designed to give smooth and gradual control of sound volume.

Function Switch

The knob directly to the right of the large station selector knob adjusts for the various functions desired. As indicated on the front escutcheon panel the positions are AM, TV and Phono. Turn to desired position.

Treble Control

The second knob to the left of the station selector controls the amount of high audio tones to be reproduced. Turn clockwise to increase high tones or counter-clockwise to decrease high tones. Set for individual preference.

Off-On Bass Control

This knob is the second knob to the right of the station selector. This control regulates the amount of low frequency or "Bass" response to be reproduced. Turn clockwise to increase Bass response and counter-clockwise to decrease. Set for individual preference.

TUNING THE RECEIVER

To receive broadcast station programs proceed as follows:

1. Turn the knob marked "Off-On Bass" clockwise about half way. The dial will illuminate indicating that the receiver is connected to the power source. Allow about thirty seconds as warm-up time for tubes.
2. Turn the function switch to AM position.
3. Turn the large station selector knob to a dial number of a local station.
4. Turn the volume control clockwise slowly to the desired level. Re-adjust the station selector knob until reception is clearest.
5. Adjust the "Bass" and "Treble" controls until the reproduction is most pleasing.

For phonograph or TV sound operation turn the function knob to the desired position and use Volume, Bass & Treble controls as described.

FUSE REPLACEMENT

A fuse is provided for the protection of the receiver against excessive power line voltages or failure of any component which would cause heavy current drain and fire hazard. **CAUTION:** Always replace the defective fuse with one of the same rating. If the fuse continues to blow after replacement, remove the receiver chassis for examination and service by qualified personnel. The fuse is accessible at the rear panel of the chassis.

A license and rating label located on the cabinet wall gives the tube socket locations. Consult this chart when testing or replacing tubes.

I.F. Alignment - 455 kc

1. Connect suitable output meter with 8 ohm shunt load across speaker terminals located on rear of chassis.
2. Connect signal generator "hot side" through a .01 mfd. paper condenser to pin 7 on the 6BE6 socket. Connect generator ground to receiver chassis. Bass, Treble and Volume in maximum position.
3. Set signal generator to 455 kc and receiver dial to 1600 kc. Adjust T2 Top and Bottom Cores for maximum output. Adjust T1 Top and Bottom Cores for maximum output. Always keep generator output at low level to assure sharp tuning of the cores. Repeat procedure until no increase in output is noted.

VOLTAGE CHART

Tube	Pin 1	Pin 2	Pin 3	Pin 4	Pin 5	Pin 6	Pin 7	Pin 8
6BE6	-15	0	A.C. 6.3	0	140	140	0	--
6BA6	.3	0	A.C. 6.3	0	130	140	1.6	--
6SQ7	0	-1	0	-5	-5	70	0	A.C. 6.3
6SN7	0	80	3	22	120	30	0	A.C. 6.3
6V6	0	0	230	240	6	30	A.C. 6.3	13
6V6	0	0	230	240	1.7	120	A.C. 6.3	13
5Y3GT	270	--	A.C. 280	--	A.C. 280	--	270	--

All voltages taken with Voltohmyst or equivalent VTVM between indicated pin and chassis frame. Unless indicated, voltages are d.c. and positive in respect to chassis.

MODEL 9030

Line voltage - 117V a.c.

Selector switch in AM position with no signal input.

R.F. Alignment

1. Connect signal generator "hot side" loosely to the loop antenna coil. (Clipping to the sleeving about 1/4" from coil winding gives adequate coupling.) Output meter connections remain the same as for I.F. alignment. Bass, Treble and Volume controls in maximum positions.
2. Set signal generator and receiver dial to 1600 kc. Adjust C1 trimmer on tuning gang for maximum output.
3. Set signal generator and receiver dial to 600 kc. Remove tape from Ferrite Rod coil L1 and slide to a position giving maximum output. Secure coil with tape after adjustment.
4. Set signal generator and receiver dial to 1400 kc. Adjust C2 trimmer on tuning gang for maximum output. Repeat steps 3 & 4 until uniform sensitivity is obtained across the entire tuning range.

PART NO.	DESCRIPTION
ALA-10032A	Antenna Ferrite Rod
CC-15500	50MMF 500V. Ceramic Condenser
CM-15680	68MMF 500V. Ceramic Condenser
CC-15101	100MMF 500V. Ceramic Condenser
CCX-10005	2 X 100MMF 500V. Condenser Ceramic
CL-10075	Electrolytic Condenser 40-20-40-450V
CM-15391	Mica Cap. 390MMF 500V
CM-15430	Mica Cap. 430MMF 500V
CMX-10002	Herlic .005MFD 500V Condenser
CVB-10028	Cond. Variable 2 Gang AM
DB-10000	Lamp-6-8V .150 Amp.
DD-10015	Idler Pulley Shaft
DD-10016	Dial Shaft Collar
DDA-10017	Shaft-Dial Drive
DI-10012	Dial Pointer
DM-10002	Dial Cord Tension Spring
DP-10015	Dial Idler Pulley
DSB-10119	Dial Glass With Calibration
FA-10000	Fuse-3 Amp. 3 AG
KA-10131	Knob-Brown-Red Arrow
KA-10132	Knob-#3000-Brown
RX-10030	Wire Wound Resistor-2500 Ohm 10 Watt
TOB-10059	Output Transformer
TP-10021	Power Transformer
TRC-10026	AM-Oscillator Coil
TSA-10058	IF-AM Coil
VCA-11110	Pot. Volume .5 Meg.
VCA-11111	Pot. Treble .5 Meg.
VCA-11112	Pot. Bass Off & On .5 Meg.
VSA-10021A	Switch Selector
6BE6	Tube
6BA6	Tube
6SQ7	Tube
6V6	Tube
5Y3	Tube

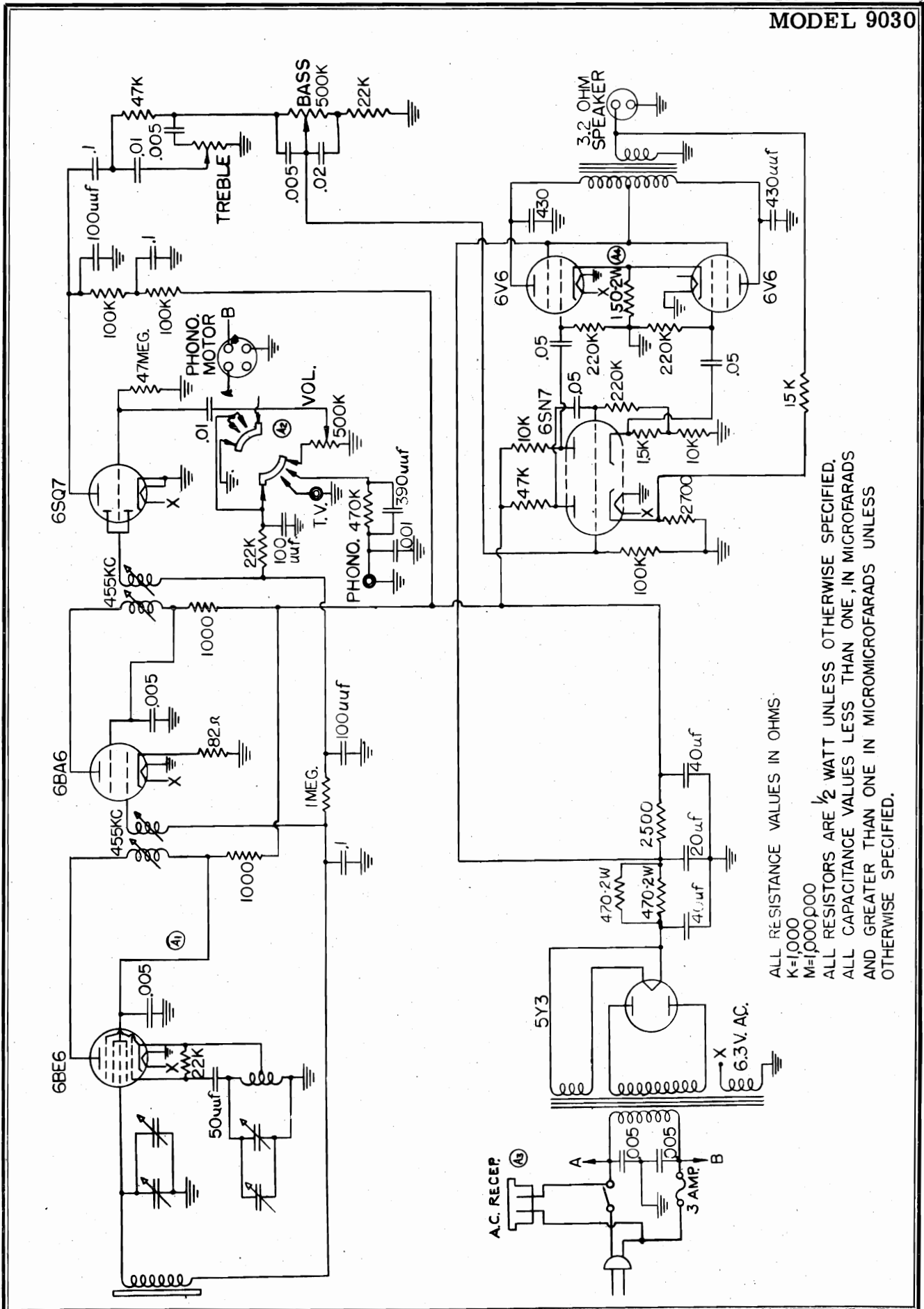

ALL RESISTANCE VALUES IN OHMS.
K=1,000
M=1,000,000
ALL RESISTORS ARE 1/2 WATT UNLESS OTHERWISE SPECIFIED.
ALL CAPACITANCE VALUES LESS THAN ONE, IN MICROFARADS
AND GREATER THAN ONE IN MICROMICROFARADS UNLESS
OTHERWISE SPECIFIED.

SETTING OF CLOCK

This clock-radio is equipped with a self-starting clock. As soon as the power plug is inserted into the wall outlet, the sweep second hand will begin to operate.

To set the time hands, rotate the time set knob located at the rear of cabinet. Once the clock is set, it needs no further attention unless you remove the plug or there is a power interruption.

INSTRUCTIONS FOR USE OF CLOCK WITH RADIO OR EXTERNAL APPLIANCE

By carefully following the instructions illustrated below, the clock may be used to perform any of the following functions:

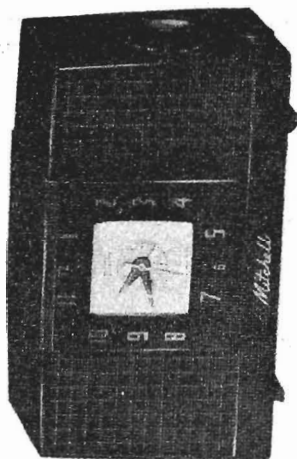

CONNECTING THE SET

POWER SUPPLY. This receiver is designed to operate on an alternating current supply (AC) ranging from 110 to 120 volts, 60 Cycles only. Do Not Operate on Direct Current.

Before connecting the set be sure that your house is wired for the voltage and current for which the set is designed. If in doubt, call your local power company for the necessary information. Connecting the set to a supply outlet furnishing the wrong type of current will result in improper operation or damage.

ANTENNA. This receiver has a built-in "loop" aerial. Its excellent design is such as to increase pick-up from stations having wide variations in signal strength. The efficiency and selectivity of the loop provide outstanding reception without the use of an external aerial.

TUBES. Four tubes (including rectifier) are used. Type numbers and locations are shown in the tube location diagram on the cabinet back.

GROUND. No ground connection should be used when operating this receiver. The receiver gets its ground connection through the power line and any external connection to the chassis may cause a short circuit and consequent damage.

CAUTION. Do not place receiver on hot objects such as stoves, radiators, etc. Heat will damage the cabinet and the internal components of the receiver.

RADIO OPERATION

USE AUTO-OFF-ON SWITCH KNOB At 9 o'clock position on clock face. Turn this knob to the right (clockwise), so that the indicator points to "ON", to turn on the radio. To turn off the radio, turn this knob so that the indicator points to "OFF".

VOLUME CONTROL KNOB (Bottom Knob on Side of Cabinet). This knob controls the volume of the signal received. To reduce the volume, rotate this knob to the left (counter-clockwise). When this knob is rotated to the right it will increase the volume.

STATION SELECTOR KNOB (Large Knob on Side of Cabinet). Rotate this knob over a narrow range of the dial where the desired station is located, until the station is received with a maximum volume and clarity. Then readjust the volume control to the proper level. NEVER use the station selector knob to adjust the volume as this will result in the signal being received with distorted tone quality.

The dial scale is calibrated in Kilocycles with the last zero of the actual frequency omitted. For instance, the numeral 55 on the scale indicates 550 Kilocycles and 160 indicates 1600 Kilocycles.

ILLUSTRATION 1

TO AWAKEN TO MUSIC

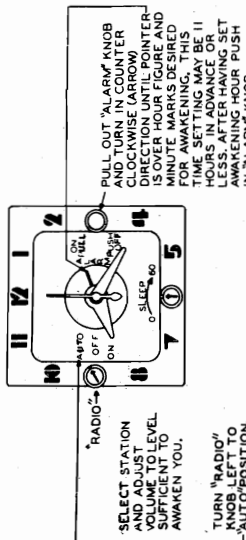

ILLUSTRATION 2

TO AWAKEN TO BUZZER ALARM

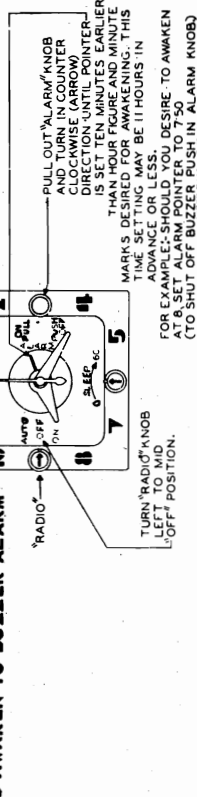

ILLUSTRATION 3

TO AWAKEN TO MUSIC AND BUZZER ALARM

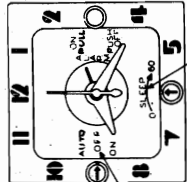
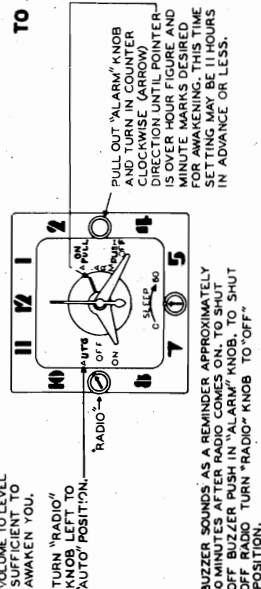
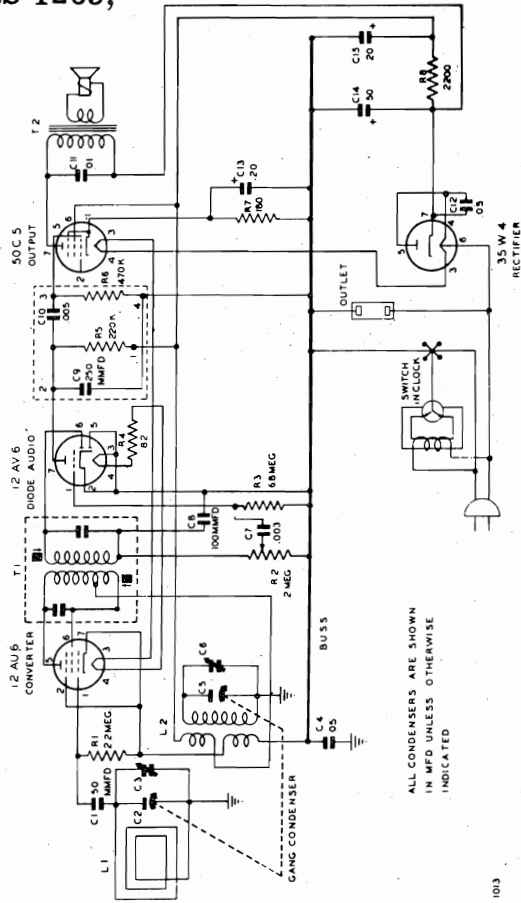

ILLUSTRATION 4

TO TURN RADIO OFF AUTOMATICALLY WHEN RETIRING

MODELS 1263,
1264



REF. NO.	PART NO.	DESCRIPTION
C1	N-6385	Capacitor - Ceramic 50 MMFD. 500 Volts 10%
C2, C5	N-8675	Gang Tuning Condenser
C4	N-1345	Capacitor - Paper .05 MFD. 200 Volts
C7	N-2063	Capacitor - Paper .003 MFD. 600 Volts
C8	N-6015	Capacitor - Ceramic 100 MMFD. 500 Volts
* C9	N-6488	Capacitor - Ceramic 250 MMFD. 500 Volts
* C10	N-4894	Capacitor - Paper .005 MFD. 600 Volts
C11	N-1344	Capacitor - Paper .01 MFD. 400 Volts
C12	N-1346	Capacitor - Paper .05 MFD. 400 Volts
C13)	N-8677	Capacitor - Electrolytic (50 MFD. 150 Volts)
C14)		(20 MFD. 150 Volts)
C15)		(20 MFD. 150 Volts)
R1	N-4277	Resistor - 2.2 Megohm - 1/2 Watt - 20%
R2	N-8674	Vc ume Control 2.0 Megohm
R3	N-4028	Resistor - 6.8 Megohm - 1/2 Watt - 20%
R4	N-4023	Resistor - 82 Ohms - 2.0 Watts - 10%
* R5	N-4026	Resistor - 220,000 Ohms-1/2 Watt - 20%
* R6	N-4027	Resistor - 470,000 Ohms-1/2 Watt - 20%
R7	N-4067	Resistor - 180 Ohms - 1/2 Watt - 10%
R8	N-4896	Resistor - 2,200 Ohms - 1/2 Watt - 10%
T1	N-7694	Coil - 1ST, I. F.
L1	N-8759	Coil - Loop Antenna
L2	N-8681	Coil - Oscillator
N-7824		Speaker - 4" PM with Transformer

* The resistors (R5 and R6) and condensers (C9 and C10) are replaced by N-8215 Couplate.

TO TURN RADIO OFF AUTOMATICALLY WHEN RETIRING AND AWAKEN TO MUSIC.
Set controls as in Illustration 1 and set "Sleep" knob as in Illustration 4.

TO TURN RADIO OFF AUTOMATICALLY WHEN RETIRING AND AWAKEN TO BUZZER ALARM.
Set controls as in Illustration 2 and set "Sleep" knob as in Illustration 4.

TO TURN RADIO OFF AUTOMATICALLY WHEN RETIRING, AWAKEN TO MUSIC AND BUZZER ALARM.
Set controls as in Illustration 3 and set "Sleep" knob as in Illustration 4.

TO AUTOMATICALLY TURN ON RADIO AND EXTERNAL ELECTRICAL APPLIANCE.
Insert plug of appliance into the electrical outlet provided at rear of receiver and set clock controls as in Illustration 1.

This feature may be used with any electrical appliance which operates on a 110-120 volt, 60 cycle power supply and which DOES NOT EXCEED THE WATTAGE RATING FOR THE OUTLET SHOWN ON THE CABINET BACK.

Current is available at this outlet whenever the radio is turned on.

TO TURN RADIO AND APPLIANCE OFF AUTOMATICALLY.
The controls may be set to turn off the radio and appliance at any time up to 60 minutes after the original starting time.

To use this feature, simply plug in the appliance, turn the AUTO-OFF-ON SWITCH KNOB to the "Off" position rotate the "Sleep" knob in a clockwise direction for the length of time required.

Precise time setting with this "Sleep" control will require practice.

ALIGNMENT

Step No.	Position of Gang	Signal Generator Frequency	Generator Connection	Dummy Antenna	Adjustment	Type of Adjustment
1.	Open	455 KC.	Rear Gang Terminal	.1 Mfd.	I. F. Slugs	Adjust for Maximum Output
2.	Open	1620 KC.	Dummy Antenna	2 Turns of Hookup Wire 6" in Dia. (Place Approx. a Foot from & parallel to loop.)	Front Gang Trimmer	Adjust for Maximum Output
3.	1400 KC	1400 KC.	Dummy Antenna		Rear Gang Trimmer	Adjust for Maximum Output
4.	600 KC	600 KC.				Check Gang Alignment

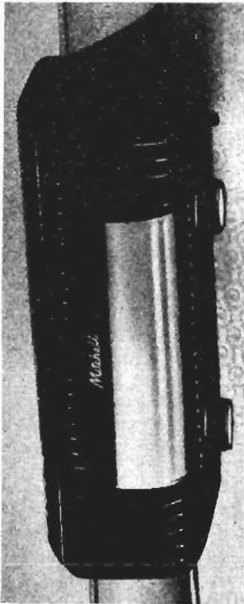

Model No. 1261 Mahogany
Model No. 1262 Ivory

This Bed Lamp-Radio incorporates the latest developments and refinements devised by radio engineers. In order to realize the advantages to the fullest, you must thoroughly understand its operation and use. **PLEASE READ INSTRUCTIONS CAREFULLY BEFORE ATTEMPTING TO USE RECEIVER.**

CONNECTING THE SET

MOUNTING OF RECEIVER. Hardware for mounting this Bed Lamp-Radio is included in an envelope packed with this receiver. Instructions printed on this envelope should be followed for best results.

POWER SUPPLY. This receiver is designed to operate on any alternating current supply (AC) ranging from 110 to 120 volts, 50 to 60 cycles: or on any direct current supply (DC) ranging from 110 to 120 volts.

SPECIAL INSTRUCTIONS FOR DC OPERATION. When operating from a DC (direct current) power supply, it may be necessary to reverse the power cord plug in the wall socket before the receiver will function.

ANTENNA. This receiver has a built-in "loop" aerial. Its excellent design is such as to increase pick-up from stations having wide variations in signal strength. The efficiency and selectivity of the loop provide outstanding reception without the use of an external aerial.

GROUND. No ground connection should be used when operating this receiver. The receiver gets its ground connection through the power line and any external connection to the chassis may cause a short circuit and consequent damage.

CONTROLS AND OPERATION

RIGHT HAND KNOB. (Volume Control and "On-Off" Switch). Turn knob to the extreme right, wait for tubes to become heated, then adjust volume as desired.

LEFT HAND KNOB. (Station Selector). Rotate knob until desired station is received with maximum volume; then re-adjust volume to desired level. Never use the station selector to adjust volume as this practice results in distorted tone quality and deficient bass response.

LAMP SWITCH. (Small knob near base of receiver). Turn knob to right to turn on lamp. Turning knob again to right will turn off lamp. Lamp operates independently of radio.

TUNING RANGE

This receiver is designed to operate over the standard broadcast band which extends from 540 to 1600 Kilocycles (KC). **DIAL CALIBRATION.** The scale is calibrated from 55 to 160 (Standard Broadcast). This band covers all Standard Broadcast frequencies of the United States, Canada, Mexico, Cuba and many Central and South American Countries. Add a zero to figures on the scale to obtain kilocycles.

TUBE AND LAMP DATA

TUBES. Five tubes (including rectifier) are used. Type numbers and locations are shown in the tube location diagram on the cabinet. If tubes are removed for test purposes, make certain each tube is replaced in its proper socket. Failure to replace tubes in their proper sockets may result in damage to the tube, or to the receiver, or both.

LAMP. This receiver uses a show case lamp of 120 volts, 25 watts with medium screw base. The lamp is accessible for replacement after removing shade. (Never use a lamp larger than 25 watts).

SHADE REMOVAL. Place thumbs at outside top edges of shade and pull down slowly until shade snaps out of upper slot.

SHADE REPLACEMENT. Insert shade into bottom slot and with fingers of both hands spaced along top edge of shade, bow toward top slot and snap into place.

CARE MUST BE TAKEN NOT TO BOW SHADE MORE THAN NECESSARY.

SERVICE DATA

Lack of sensitivity and poor tone quality may be due to any one or a combination of causes such as weak or defective tubes or speaker, open or grounded bias resistor, bypass condenser, etc. Never attempt to realign set until all other possible sources of trouble have been first thoroughly investigated and definitely proved not to be the cause.

NOTE: IT IS ABSOLUTELY NECESSARY THAT AN ACCURATELY CALIBRATED TEST OSCILLATOR WITH SOME TYPE OF OUTPUT MEASURING DEVICE BE USED WHEN ALIGNING THE RECEIVER AND THAT THE PROCEDURE BE CAREFULLY FOLLOWED, OTHERWISE THE RECEIVER WILL BE INSENSITIVE AND THE DIAL CALIBRATION WILL BE INCORRECT. THE TRIMMERS WILL BE REFERRED TO BY THEIR FUNCTION AS INDICATED ON THE PARTS DIAGRAM.

ALIGNMENT PROCEDURE

STEP NO.	POSITION OF GANG	SIGNAL GENERATOR FREQUENCY	GENERATOR CONNECTION	DUMMY ANTENNA	ADJUSTMENT	TYPE OF ADJUSTMENT
1.	Open	455 KC.	Rear Gang Terminal	.1 Mfd.	I.F. Slugs	Adjust for Maximum Output
2.	Open	1620 KC.	Dummy Antenna	2 Turns of Hookup Wire 2" in Dia. (Place Approx. a Foot from & parallel to loop.)	Front Gang Trimmer	Adjust for Maximum Output
3.	1400 KC.	1400 KC.			Rear Gang Trimmer	Adjust for Maximum Output
4.	600 KC.	600 KC.				Check Gang Alignment

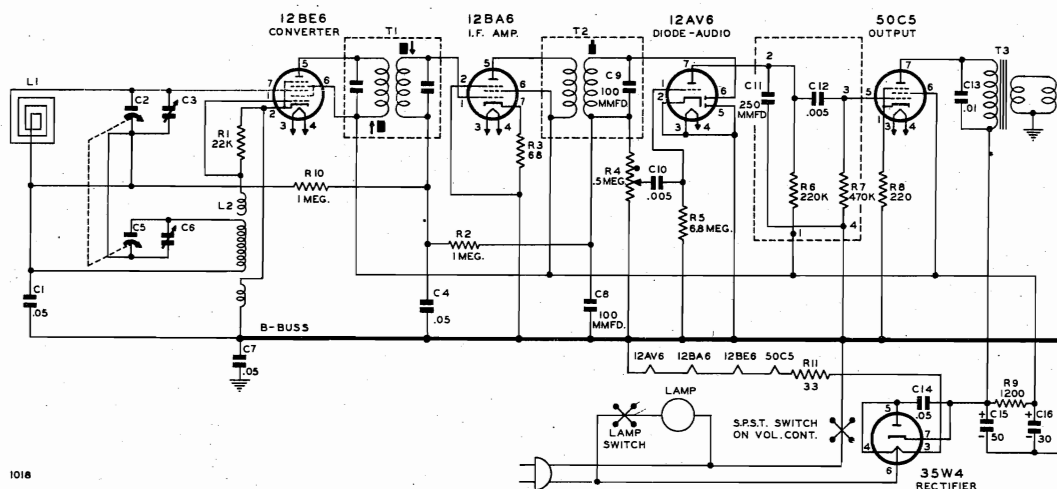

REF. NO.	PART NO.	DESCRIPTION	REF. NO.	PART NO.	DESCRIPTION
C1,C4,C7	N-1345	Condenser, Paper .05 MFD. 200 V.	R4	N-7890	Volume Control with switch 0.5 Megohm
C2,C5	N-8801	Condenser, Gang Tuning	R5	N-4028	Resistor 6.8 Megohms 1/2 Watt 20%
C3,C6	-	Trimmers on Gang Condenser	*R6	N-4026	Resistor 220,000 Ohms 1/2 Watt 20%
C8	N-6015	Condenser, Ceramic 100 MMFD. 500 V. 20%	*R7	N-4027	Resistor 470,000 Ohms 1/2 Watt 20%
C9	Part of	N-8796 2nd I.F. Coil	R8	N-4024	Resistor 220 Ohms 1/2 Watt 10%
C10,*C12	N-4894	Condenser, Paper .005 MFD. 600 V.	R9	N-4900	Resistor 1200 Ohms 1.0 Watt 10%
*C11	N-6488	Condenser, Ceramic 250 MMFD. 500 V.	R11	N-4068	Resistor 33 Ohms 1.0 Watt 20%
C13	N-1344	Condenser, Paper .01 MFD. 400 V.	L1	N-8247	Speaker, 3 1/2" P.M.
C14	N-1346	Condenser, Paper .05 MFD. 400 V.	L2	N-8795	Loop Coil
C15)	N-8873	Electrolytic (50 MFD. 150 V.)	L3	N-8797	Oscillator Coil
C16)		(30 MFD. 150 V.)	T1	N-7981	1st I.F. Transformer
R1	N-4025	Resistor 22,000 Ohms 1/2 Watt 20%	T2	N-8796	2nd I.F. Transformer
R2,R10	N-1262	Resistor 1.0 Megohm 1/2 Watt 20%	T3	N-7899	Output Transformer
R3	N-6485	Resistor 68 Ohms 1/2 Watt 10%			

* Some sets were produced with an Audio Couplate, part number N-8215, to replace resistors (illus. No. R6 and R7) and Condensers (illus. No. C11 and C12).

CONTROLS AND OPERATION

BOTTOM KNOB. (Manual Volume Control and "On-Off" Switch). Turn this knob to the extreme right. Wait about a minute for the tubes to become heated. When signal comes in adjust volume as desired.

TOP KNOB. (Station Selector) Move the knob over a narrow range of the dial at a point where the desired station is located, until the station is received with maximum volume; then readjust the volume control to the proper level. Never use the station selector to adjust volume as this practice results in distorted tone quality and deficient bass response. The Volume Control only is to be used for this purpose. For maximum clarity the indicator should be adjusted to the center of the area covered by the station being tuned.

TUNING RANGE

This receiver is designed to operate over the standard broadcast band which extends from 540 to 1600 Kilocycles (KC).

DIAL CALIBRATION. The scale is calibrated from 55 to 160 (Standard Broadcast). This band covers all Standard Broadcast frequencies of the United States, Canada, Mexico, Cuba and many Central and South American Countries. Add a zero to figures on the scale to obtain kilocycles.

ALIGNMENT PROCEDURE

STEP NO.	POSITION OF GANG	SIGNAL GENERATOR FREQUENCY	GENERATOR CONNECTION	DUMMY ANTENNA	ADJUSTMENT	TYPE OF ADJUSTMENT
1.	Open	455 KC.	Rear Gang Terminal	1 Mfd.	I.F. Slugs	Adjust for Maximum Output
2.	Open	1620 KC.	Dummy Antenna	2 Turns of Hookup Wire 6" in Dia. (Place approx. a foot from & parallel to loop.)	Front Gang Trimmer	Adjust for Maximum Output
3.	1400 KC.	1400 KC.			Rear Gang Trimmer	Adjust for Maximum Output
4.	600 KC.	600 KC.				Check Gang Alignment

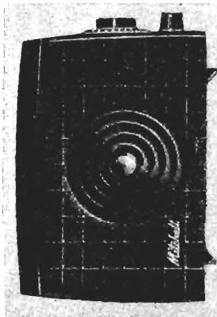

MODEL NO. 1258 RED
MODEL NO. 1259 WHITE
MODEL NO. 1266 GREEN

CONNECTING THE SET

Before connecting the set, be sure that your home is wired for the voltage and current for which the set is designed. If in doubt, call your local power company for the necessary information. Connecting the set to a supply outlet furnishing the wrong type of current will result in improper operation or damage.

POWER SUPPLY. This receiver is designed to operate on any alternating current supply (AC) ranging from 110 to 120 volts, 50 to 60 cycles; or on any direct current supply (DC) ranging from 110 to 120 volts.

SPECIAL INSTRUCTIONS FOR DC OPERATION. When operating from a DC (direct current) power supply, it may be necessary to reverse the power cord plug in the wall socket before the receiver will function, due to the polarity condition of a direct current supply. If the receiver fails to perform after being turned on one minute, simply reverse the power plug.

TUBES. Four tubes (including rectifier) are used. Type numbers and locations are shown in the tube location diagram on the cabinet back.

ANTENNA. This receiver has a built-in "loop" aerial. Its excellent design is such as to increase pick-up from stations having wide variations in signal strength. The efficiency and selectivity of the loop provide outstanding reception without the use of an external aerial. The "loop" aerial used on this receiver is somewhat directional so reception from weak stations can be improved by turning the set in the proper direction.

GROUND. No ground connection should be used when operating this receiver. The receiver gets its ground connection through the power line and any external connection to the chassis may cause a short circuit and consequent damage.

CAUTION: Do not place receiver on hot objects such as stoves, radiators, etc. Heat will damage the internal components of the receiver.

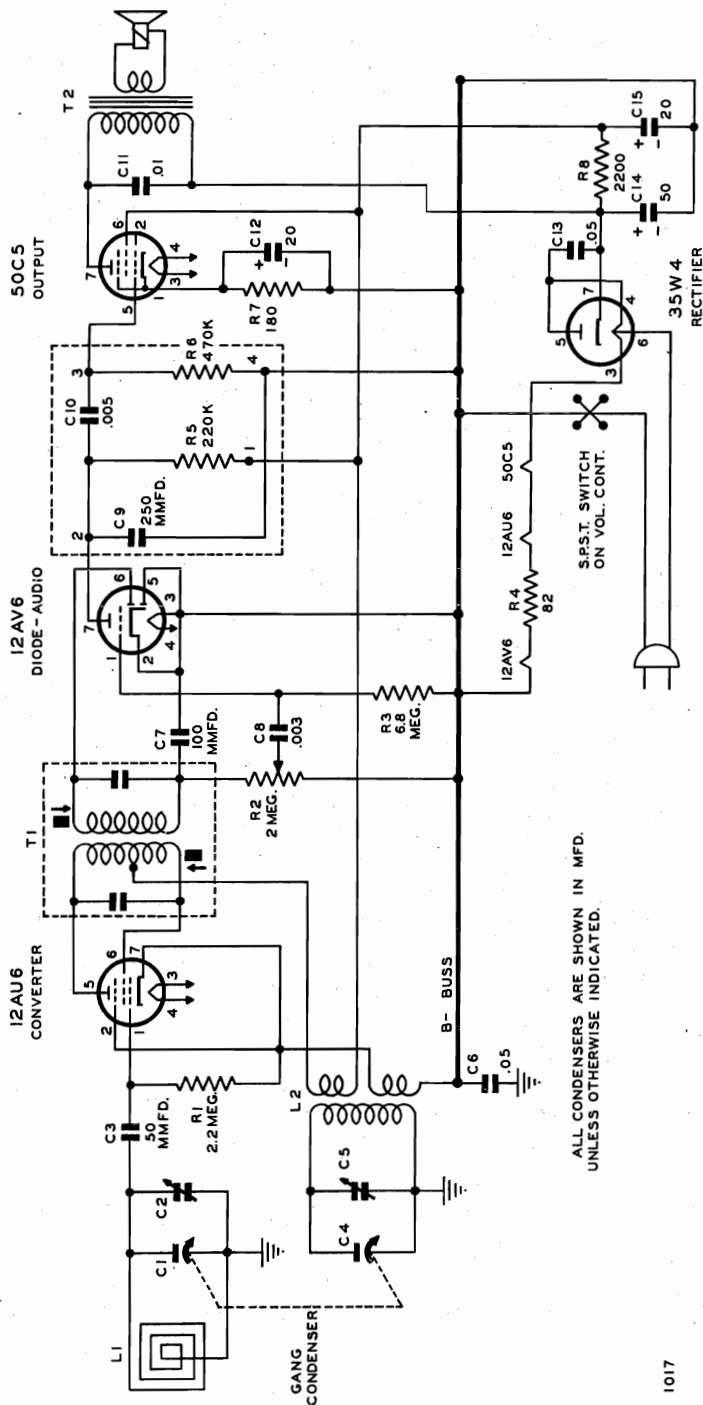

1017

PARTS LIST

C1	N-6385	Capacitor - Ceramic 50 MMFD. 500 Volts 10%	R1	N-4277	Resistor - 2.2 Megohm - 1/2 Watt - 20%
C2,C5	N-8675	Gang Tuning Condenser	R2	N-7142	Volume Control 2.0 Megohm
C4	N-1345	Capacitor - Paper .05 MFD. 200 Volts	R3	N-4028	Resistor - 6.8 Megohm - 1/2 Watt - 20%
C7	N-2063	Capacitor - Paper .003 MFD. 600 Volts	R4	N-4023	Resistor - 82 82 Ohms - 2.0 Watts - 10%
C8	N-6015	Capacitor - Ceramic 100 MMFD. 500 Volts	*R5	N-4026	Resistor - 220,000 Ohms - 1/2 Watt - 20%
*C9	N-6488	Capacitor - Ceramic 250 MMFD. 500 Volts	*R6	N-4027	Resistor - 470,000 Ohms - 1/2 Watt - 20%
*C10	N-4894	Capacitor - Paper .005 MFD. 600 Volts	R7	N-4067	Resistor - 180 Ohms - 1/2 Watt - 10%
C11	N-1344	Capacitor - Paper .01 MFD. 400 Volts	R8	N-4896	Resistor - 2,200 Ohms - 1/2 Watt - 10%
C12	N-1346	Capacitor - Paper .05 MFD. 400 Volts	T1	N-7694	Coil - 1st. I.F.
C13)	N-8677	Capacitor - Electrolytic (20 MFD. 15 Volts)	L1	N-8832	Coil - Loop Antenna
C14)		(50 MFD. 150 Volts)	L2	N-8681	Coil - Oscillator
C15)		(20 MFD. 150 Volts)	N-7824	N-7824	Speaker - 4" PM with Transformer

* The resistors (R5 and R6) and condensers (C9 and C10) are replaced by N-8215 Couplate.

MODELS 05BR-1525B, C, -1526B, C,
05BR-1531B, C, 05BR-1532B, C

GENERAL DESCRIPTION

The above mentioned models are a 5 tube, AC/DC superheterodyne receiver, designed to operate on 115 volts. The sets contain a built-in loop antenna and will operate in the standard broadcast band of 540 to 1600 kilocycles.

The only difference between the B and C series letter at the end of each model number is the rectifier tube being used. The B series sets use a 35Z5 rectifier tube while the C series sets use a 25Z6.

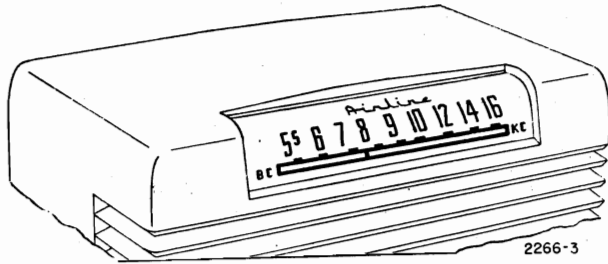

Cabinet View

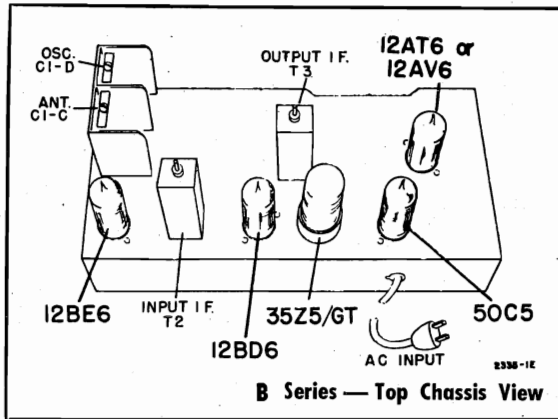

B Series — Top Chassis View

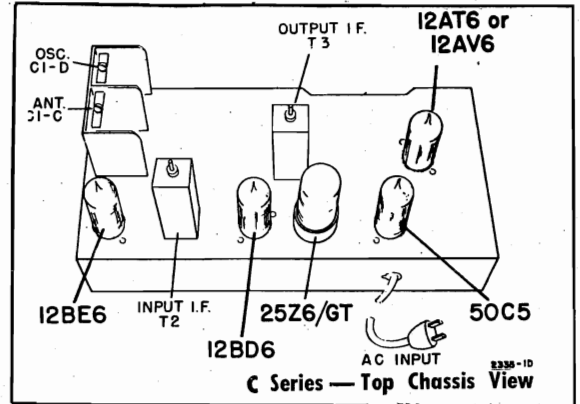

C Series — Top Chassis View

SERVICE DATA

- Power Supply..... 115 volts DC or 50-60 cycles AC, 24 watts.
- Frequency Range..... 540 to 1600 kc.
- Intermediate Freq..... 455 kc.
- Selectivity..... At 1000 kc, 60 kc at 1000 x signal
- Sensitivity..... 150 u.v. per meter.
- Power Output..... 0.8 watts undistorted, 1.0 watts maximum.
- Loud Speaker..... 4" PM., v.c. impedance, 3.2 ohms.
- Tube Complement..... 12BE6, converter, 12BD6, IF Amplifier, 12AT6 or 12AV6, detector, AVC, audio, 50C5, Output amplifier 35Z5 or 25Z6, Rectifier

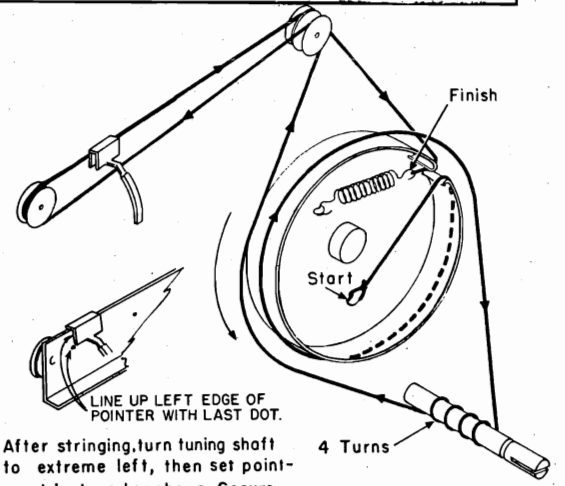

After stringing, turn tuning shaft to extreme left, then set pointer at last marker shown. Secure pointer to string with glue.

2266-2

ALIGNMENT PROCEDURE

Dial Stringing Diagram

- Loop must be connected and volume set to maximum.

SIGNAL GENERATOR				TUNER SETTING	ADJUST FOR MAXIMUM OUTPUT
Frequency	Coupling Capacitor	Connection to Radio	Ground Connection		
455 kc.	.1 mf	12BE6, Pin 7	HEAVY BUSS LEAD ACROSS CENTER OF CHASSIS	Capacitor fully open (plates out of mesh)	Top and bottom Cores in output and input I.F. cans
1620 kc.	.1 mf	12BE6, Pin 7		Capacitor fully open (plates out of mesh)	Oscillator trimmer C1-D on gang
535 kc.	.1 mf.	12BE6, Pin 7		Capacitor fully closed	Check for adequate range
1400 kc.	_____	Lay generator lead near back of cabinet		Tune in 1400 kc. signal	Antenna trimmer C-1C on gang

463-1

MODELS 05BR-1525B, C -1526B, C, 05BR-1531B, C, 05BR-1532B, C

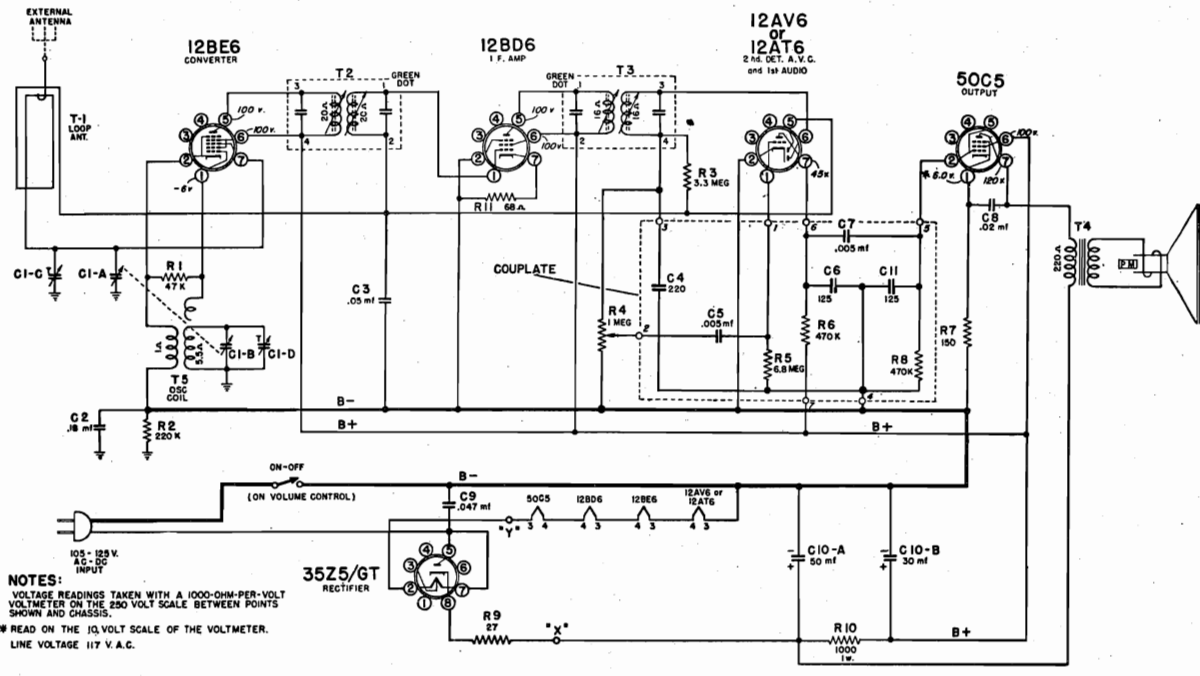

NOTES:
 VOLTAGE READINGS TAKEN WITH A 1000-OHM-PER-VOLT
 VOLTMETER ON THE 250 VOLT SCALE BETWEEN POINTS
 SHOWN AND CHASSIS.
 * READ ON THE 10 VOLT SCALE OF THE VOLTMETER.
 LINE VOLTAGE 117 V. A. C.

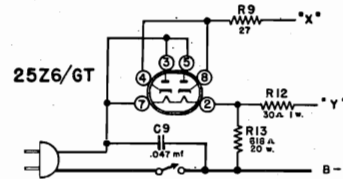

NOTICE:
 THIS MODEL USES ONE OF THE TWO
 RECTIFIER CIRCUITS SHOWN.

SCHEMATIC DIAGRAM

Ref. No.	Part No.	Description	Selling Price	Ref. No.	Part No.	Description	Selling Price
CAPACITORS				DIAL PARTS			
C1A, B	8A-17377	2-gang condenser	1.44	3A-17590	Tuning shaft	.12	
C1C, D		Trimmers on gang		40A-17591	Bushing	.02	
C2	8D-11111	.18 mfd x 400 volts	.22	29E-17592	Spring washer	.02	
C3	8D-10770	.05 mfd x 200 volts	.14	43D-17609	Tinnerman clip	.02	
C4-5-6-7-11, and R5-6-8	201-19303	Couplate	.54	29C-10630	"C" washer	.02	
C8	8D-17607	.02 mfd x 400 volts	.18	2G-17382	Dial pointer	.06	
C9	8J-16081	.047 mfd x 400 volts	.18	6D-17389	Dial scale	.58	
C10A, B	8C-17391	Electrolytic condenser	.74	3M-18614	String guide	.06	
RESISTORS				MISCELLANEOUS			
R1	9B1-82	47K ohms, 1/2 watt, 10%	.14	5C-17534-36	Cabinet (walnut)	1.98	
R2	9B1-27	220K ohms, 1/2 watt, 20%	.14	5C-17534-77	Cabinet (green)	2.96	
R3	9B1-34	3.3 megohms, 1/2 watt, 20%	.14	5C-17534-22	Cabinet (red)	2.94	
R4	10A-19616	1 megohm, volume control and switch	.76	5C-17534-9	Cabinet (ivory)	2.26	
R5-6-8		See Couplate		5B-10011-8	Knob (ivory), for green, red or ivory cabinets	.12	
R7	9B1-52	150 ohms, 1/2 watt, 10%	.14	5B-10011-37	Knob (walnut)	.12	
R9	9B1-43	27 ohms, 1/2 watt, 10%	.14	18A-17579	Speaker, 4" P.M.	1.98	
R10	9B2-62	1000 ohms, 1 watt, 10%	.20	15B-10440	8-prong, octal socket	.10	
R11	9B1-48	68 ohms, 1/2 watt, 20%	.14	15C-16007	7-prong, miniature socket	.10	
R12	9C-19769	30 ohms, 1 watt, clarostat	.10	2M-17589	Tube shield base	.04	
R13	9M-19602	618 ohms, 20 watts, clarostat	.66	2H-18841	Tube shield	.10	
TRANSFORMERS AND COILS				2M-17580			
T1	13E-18755	Loop antenna	.76	14M-10088-4	A.C. line cord and plug	.60	
or	13E-17587	Loop antenna	.52	23A-10344	Line cord lock	.02	
T2	13B-17397	Input I. F. transformer	.88	42A-10097	Chassis mounting bolt	.02	
T3	13B-17399	Output I. F. transformer	.82	29A-2164	Chassis mounting washer	.02	
T4	12C-19302	Output transformer	.60	134-103	Chassis rubber washer	.02	
or	12C-17595	Output transformer	.60		I. F. mounting clip	.02	
T5	13D-17583	Oscillator coil	.42				

IMPORTANT—All prices in this literature are subject to change without notice and are subject to an additional charge to cover any applicable sales tax, use, occupation, or other tax affecting our purchase or sale of merchandise.

MODELS 15BR-1525D, 15BR-1526D,
15BR-1531D, 15BR-1532D

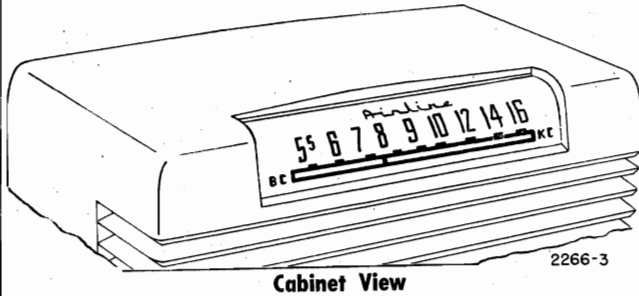

Cabinet View

2266-3

SERVICE DATA

Power Supply 115 volts, DC or 50-60 cycle AC,
24 watts.
Frequency Range 540 to 1600 Kc.
Intermediate Freq. 455 Kc.
Selectivity At 1000 Kc., 60 Kc. at 1000 x
signal
Sensitivity 150 u. v. per meter.
Power Output 0.8 watts undistorted, 1.0 watt
max.
Loud Speaker 4" PM., v.c. impedance, 3.2 ohms.
Tube Complement
12BE6, Converter 50C5, Audio output
12BA6, IF Amplifier 25Z6, Rectifier
12AV6 or 12AT6,
Detector, AVC, Audio

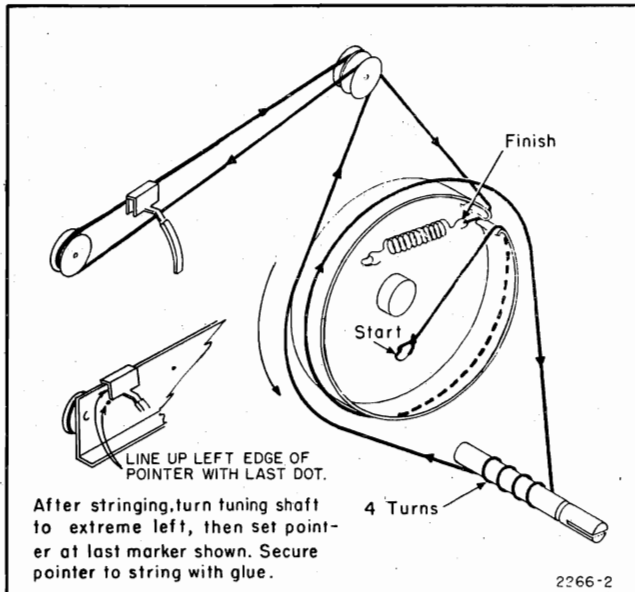

Dial Stringing Diagram

2266-2

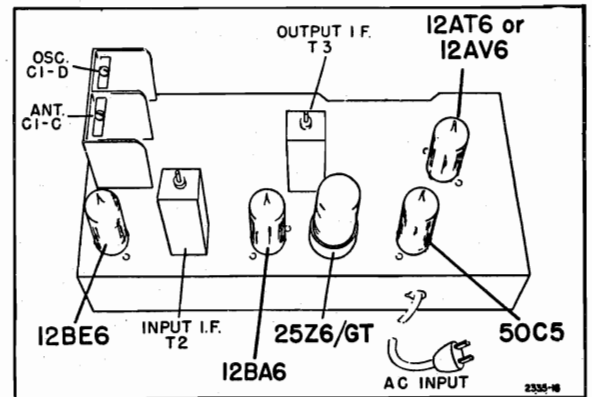

ALIGNMENT PROCEDURE

- Loop must be connected and volume set to maximum.

SIGNAL GENERATOR				TUNER SETTING	ADJUST FOR MAXIMUM OUTPUT
Frequency	Coupling Capacitor	Connection to Radio	Ground Connection		
455 kc.	.1 mf	12BE6, Pin 7	HEAVY BUSS LEAD ACROSS CENTER OF CHASSIS	Capacitor fully open (plates out of mesh)	Top and bottom Cores in output and input I.F. cans
1620 kc.	.1 mf	12BE6, Pin 7		Capacitor fully open (plates out of mesh)	Oscillator trimmer C1-D on gang
535 kc.	.1 mf.	12BE6, Pin 7		Capacitor fully closed	Check for adequate range
1400 kc.	_____	Lay generator lead near back of cabinet		Tune in 1400 kc. signal	Antenna trimmer C-1C on gang



GENERAL DESCRIPTION

This is a four tube (plus rectifier) AC operated Radio or Record player. The record playing mechanism is designed to play any of the 33, 45, or 78 RPM records. Ten or twelve inch records may be intermixed provided they are of the same type.

INSTALLATION

PREPARING FOR OPERATION

Shipping Bolts: Before placing in operation, the changer must be floated freely on the mounting springs. During shipping, the mechanism is secured by means of two machine screws on either side of the base plate. These two screws are to be loosened sufficiently to allow the changer to float freely on its springs.

Location: The phonograph should be placed on a level surface convenient to an electric outlet. Do

not place the phonograph near a radiator, or other heater, since certain elements may be damaged.

Power Supply: This phonograph is designed for operation from 105-125 volt, 60-cycle alternating current (ac) supply only. If you are not sure of the power voltage and frequency at your home, your power company will furnish the information.

ELECTRICAL SPECIFICATIONS

- Power Supply 105 to 125 volts A.C.
60 cycle. 50 watts with record player operating.
- Frequency Range 535 to 1620 KC
- Intermediate Frequency 455 KC
- Selectivity 40 KC broad at 1000 times signal, 1000 KC
- Sensitivity (.05 watt output with Hazeltine test loop) 350 Microvolt per meter average.
- Power Output 1.1 watts max. .7 watts 10% distortion.
- Loud Speaker 5" PM dynamic 1.47 oz. Alnico 5 magnet, voice coil impedance 3.2 ohms at 400 cycles
- Tube Complement 1 - 12SA7 Mixer
1 - 12SK7 I.F. Amplifier
1 - 12SQ7 Det. & A.F.
1 - 50L6 Power Amp.
1 - 35Z5 Rectifier
1 - No. 47 Dial Lamp

SPECIAL INSTRUCTIONS

Remove two wood screws holding back board. This will expose the antenna. Remove antenna plug.

Remove two wood screws holding back of chassis. Remove two nuts holding front panel. Chassis may now be removed.

REMOVAL OF RADIO CHASSIS

Remove two screws holding record changer. Lift record changer and move back, tilting at the same time. Remove changer power cord and pick up lead.

ALIGNMENT PROCEDURE

The following equipment is required for aligning: A signal generator which will provide an accurately calibrated signal at the indicated test frequencies; an output indicating meter; a non-metallic screwdriver.

Radiation Loop: 2-turn loop, 6 inches in diameter.

Conditions for Alignment:

Tone - Treble

Volume - Maximum

Selector Switch - "Radio" position

Test loop coupled loosely to receiver by spacing - receiver loop in same position as it will be with chassis in cabinet.

SIGNAL GENERATOR COUPLING	SIGNAL GENERATOR FREQUENCY	RADIO DIAL SETTING	OUTPUT METER	REMARKS	ADJUST FOR MAXIMUM OUTPUT
LOOP	455 KC	Low End of Band	Across Voice Coil	Short out osc. tuning gang section C-2; compress C-3	C-8, C-7, C-6, C-5
LOOP	1620 KC	High End of Band	"	Remove short across C-2	C-4
LOOP	1400 KC	Point of Maximum Output	"	Set pointer to 140 on dial	C-3
LOOP	600 KC	Point of Maximum Output	"	Knife C-1 plates for maximum output	
LOOP	1400 KC	1400	"	Recheck Alignment	C-3 if necessary

HOW TO REPAIR ORDER PARTS

Repair Parts may be ordered from your nearest Wards Retail Store, Catalog Order Office, or Mail Order House. To have your order filled promptly and correctly, please furnish the following information:

1. MODEL NUMBER which appears on nameplate.
2. PART NUMBER AND NAME OF PART (see Repair Parts List).

PARTS LIST

SCHEMATIC LOCATION	PART NO.	DESCRIPTION	LIST PRICE	SCHEMATIC LOCATION	PART NO.	DESCRIPTION	LIST PRICE
RESISTORS							
R1	517	22,000 OHM ½ Watt	\$.14	R5, C12	813	.01 MF 5 Meg OHM Common Terminal Connection	\$.54
R2	615	2.2 Meg OHM ½ Watt	.14	R10, C15	814	.01 MF 100,000 OHM Common Terminal Connection	.54
R3		See Capristors					
R4	520	47 OHM ½ Watt	.14	TRANSFORMERS			
R5		See Capristors		T1	1201	Output Transformer	2.26
R6	401	500,000 OHM Vol. Control with Switch	1.12	T3, T4	1402	I.F. Transformers	2.00
R7	516	1 Meg OHM ½ Watt	.14	MISCELLANEOUS			
R8, R11	502	510,000 OHM ½ Watt	.14	S1	401	On-Off Switch on Volume Control	1.12
R9	408	500,000 OHM Tone Control	.90	S2	407	Motor Switch on Changer Assembly	
R10		See Capristors		S3	1892	Radio-Phono Slide Switch	.36
R12	505	150 OHM ½ Watt	.14	PL1	307A	Loop Antenna Plug	.30
R13	607	1000 OHM 1 Watt	.18	PL2	307	Changer A.C. Plug	.30
R14	602	270 OHM 1 Watt	.18	PL3	305	Pickup Plug	.12
R15	534	30 Ohm 1/2 W.	.14	RE1	106A	Loop Antenna Receptacle	.30
CAPACITORS							
C1, C2	1004A	Tuning Gang and Trimmer Assembly	4.96	RE2	106	Changer A.C. Receptacle	.30
C3, C4				RE3	104	Pickup Receptacle	.22
C5, C6			Trimmer Condensors in I.F. Cans.		X1	2534	Pickup Cartridge EV-334
C7, C8					62-349	.0023 Needle	1.47
C9, C22	804	.1 MFD. 200 V.	.28	V2503BZ		Tone Arm less Cartridge Strengtheners and Bracket Assembly	1.60
C10, C11		See Capristors		V-2917			.64
C12		See Capristors		LS1 - T1	2607	5" Speaker and Output Transformer	6.16
C13	817	250 MMF. Ceramic	.28		2411	Knob	.22
C14	825	.01 MF. Ceramic	.40	T2	1512	Loop Antenna	2.25
C15		See Capristors			1736A	Dial Pointer	.22
C17	824	.005 MF. Ceramic	.40		2307	Dial Bezel	.32
C18, C19	1003	40-40-20 MFD/150 Volts	2.34		2146	Front Panel	2.30
C20, C16			20 MFD/25 Volts			1722C	Dial
C21	803A	.05 400 V. Tubular	.28				
CAPRISTORS							
R3, C10	811	100 MMF. 50,000 OHM 100 MMF Dual Shunt Connection	.72				

IMPORTANT - All prices in this literature are subject to change without notice and are subject to an additional charge to cover any applicable sales tax, use, occupation, or other tax affecting our purchase or sale of merchandise.



ELECTRICAL SPECIFICATIONS

POWER SUPPLY: 105-125 Volts AC or DC and #33 Battery

FREQUENCY RANGE: 540 to 1640 KC

INTERMEDIATE FREQUENCY: 455 KC

SENSITIVITY (For .05 Watt Output)
175 Microvolts per Meter

POWER OUTPUT: .190 Watt 10% Distortion

TUBE COMPLEMENT:

- 1—IR5 Converter
- 1—IT4 I.F. Amplifier
- 1—IU5 Det. Avc. 1st AF.
- 1—3V4 or 3Q4 Power Amplifier

LOUD SPEAKER: 4" PM Dynamic 3.2 VoiceCoil Impedance

TUBE AND TRIMMER CONDENSER LAYOUT

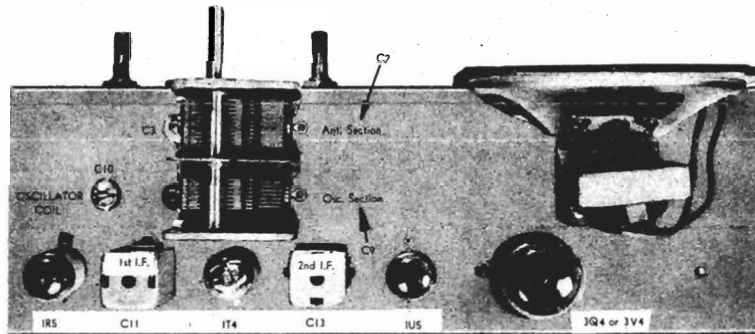

ALIGNMENT PROCEDURE

Volume Control—Maximum All Adjustments.

Signal Generator which will provide an accurately calibrated signal at the test frequencies as listed.

Output Indicating Meter; Non-Metallic Screwdriver.

The equipment in column at right is required for aligning:

Dummy Antenna —.1 mf.

Frequency Setting	SIGNAL GENERATOR		Ground Connection	Variable Condenser Setting	ADJUST TRIMMERS TO MAXIMUM See Trimmer Illustration
	Coupling Capacitor	Connection to Radio			
455 KC	.1	CONTROL GRID OF IR5	TO B-BUS BAR	CLOSED	1st AND 2nd I.F. C11-C12-C13-C14
540 KC	.1	CONTROL GRID OF IR5	TO B-BUS BAR	CLOSED	OSCILLATOR COIL SCREW
1640 KC	.1	CONTROL GRID OF IR5	TO B-BUS BAR	WIDE OPEN	OSCILLATOR TRIMMER-C10
1400 KC	.1	CONTROL GRID OF IR5	TO B-BUS BAR	TO 1400 KC SIGNAL	ANTENNA TRIMMER-C3

499-A

REPEAT PROCEDURE

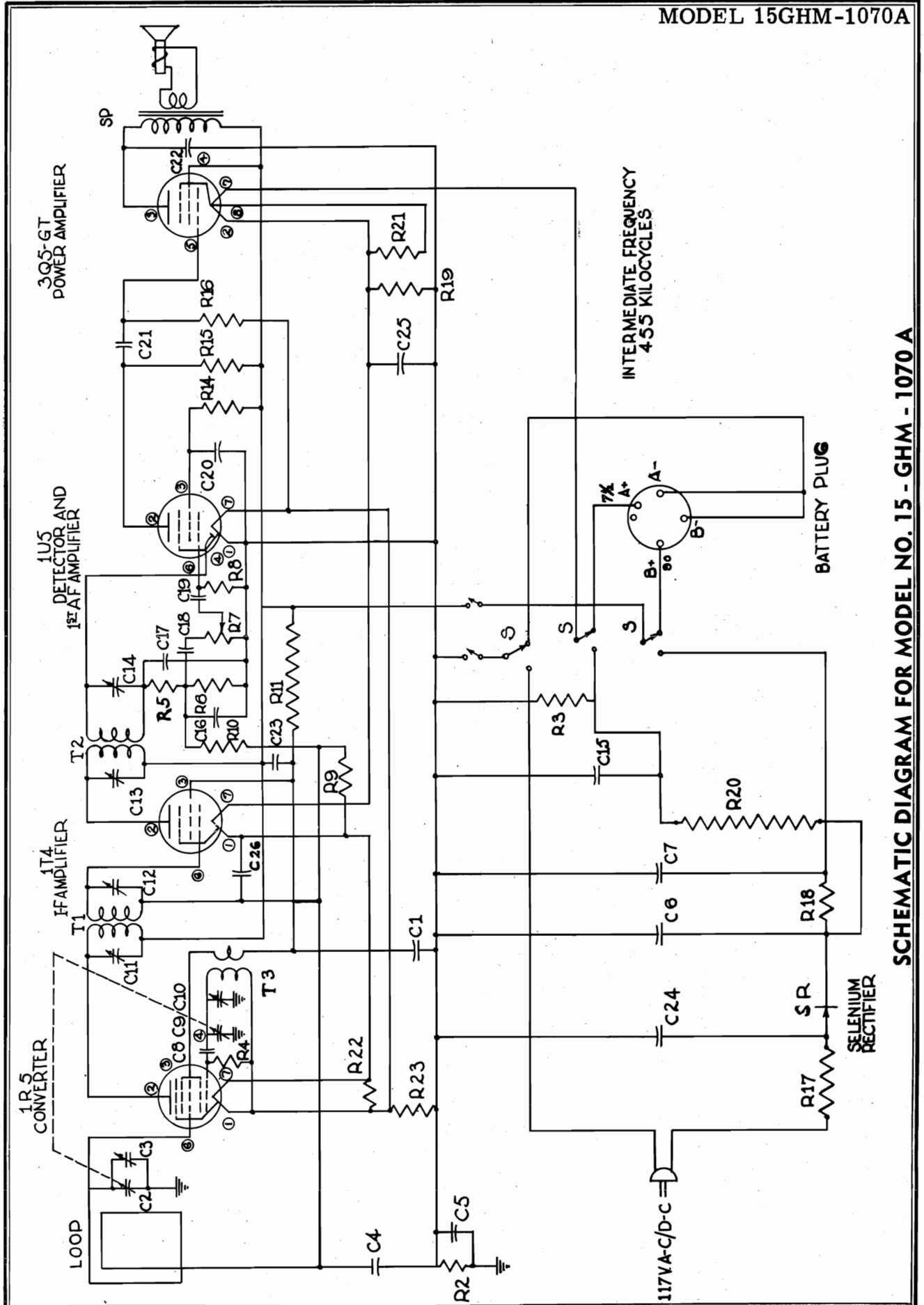

SCHEMATIC DIAGRAM FOR MODEL NO. 15 - GHM - 1070 A

MODEL 15GHM-1070A

PARTS LIST

WHEN ORDERING PART, STATE MODEL NO. OF RADIO AND PART NO.

Ref. No.	Part No.	Description	Price	Ref. No.	Part No.	Description	Price
CONDENSER				RESISTORS			
C1-20-23 26	AC1	.05-150 V.	.20	R8-9	AR7	5.6 " — 1/2 Watt	.20
C2-C3 C9-C10	AM1	2 Gang Var. Condenser	1.60	R10	AR8	2.2 " — 1/2 "	.20
C4	AC2	.1-150 V.	.25	R11	AR9	15 K — 1/2 "	.20
C5	AC3	.2-200 V.	.35	R12-R13		1 K — 1/2 "	.20
C6-C7 C15	AC4	50 MFD-150 V. (C6-C7) 200 MFD-25 V. (C15) 3 Section Filter Condenser	1.60	R14	AR11	2.5 Meg. — 1/2 "	.20
C8	AC5	50 MMF-150 V.	.20	R16	AR12	1 Meg. — 1/2 "	.20
C11-C12	-----	1st I.F. Trimmers Part of T-1		R17	AR13	25 OHM — 1 "	.25
C13-C14	-----	2nd I.F. Trimmers Part of T-2		R18	AR14	3000 " — 1 "	.25
C16-C17	AC6	100 MMF-150 V.	.20	R19	AR15	470 " — 1/2 "	.20
C18-C19	AC7	.005-150 V.	.20	R20	AR16	2500 " — 10 "	.60
C21	AC8	.01-150 V.	.20	R21-R23	AR17	360 " — 1/2 "	.20
C22	AC9	.006-150 V.	.20	R22	AR18	510 " — 1/2 "	.20
C24	AC10	.05-400 V.	.25	MISCELLANEOUS			
C25	AC11	100 MFD-25 V.	.60	SP	AM2	4" Speaker with Output Trans.	4.20
R2-R15	AR1	470 K — 1/2 Watt	.20	SR	AM3	Selenium Rectifier, 100 Mil.	1.80
R3	AR2	1800 OHM — 1/2 "	.20	T1-T2	AM4	I.F. Transformer	.90
R4	AR3	100 K — 1/2 "	.20	-----	AM5	I.F. Trans. Mounting Clip	.10
R5	AR4	47 K — 1/2 "	.20	T3	AM6	Oscillator Coil	.60
R6	AR5	560 K — 1/2 "	.20	S	AM7	Switch, "Electric-Battery"	1.00
R7	AR6	2 Meg. Vol. Control With Switch	.80	-----	AM8	Socket, Tube, Miniature	.20
				-----	AM9	Socket, Tube, Octal	.25
				-----	AM10	Dial, Tuning	1.20
				-----	AM11	Knob, "AC-DC-Battery" or "Volume"	.25
				-----	-----	Specify Push on Knob or Set Screw Knob	
				-----	AM12	Loop Antenna	1.00
				-----	AM13	Grill Cloth, Plastic	.80
				-----	AM14	Cabinet-Leatherette Covered	9.50
				-----	AM15	Line Cord with Plug	.50
				-----	AM16	Battery Plug with Leads	.50

HOW TO ORDER REPAIR PARTS

Repair Parts may be ordered from your nearest Wards Retail Store, Catalog Order Office, or Mail Order House. To have your order filled promptly and correctly, please furnish the following information:

1. **Model Number** which appears on nameplate.
2. **Part Number and Name of Part** (see Repair Parts List).

IMPORTANT—All prices in this literature are subject to change without notice and are subject to an additional charge to cover any applicable sales tax, use, occupation, or other tax affecting our purchase or sale of merchandise.

MODELS 15GSL-1564A, 15GSL-1565A,
15GSL-1566A, 15GSL-1567A

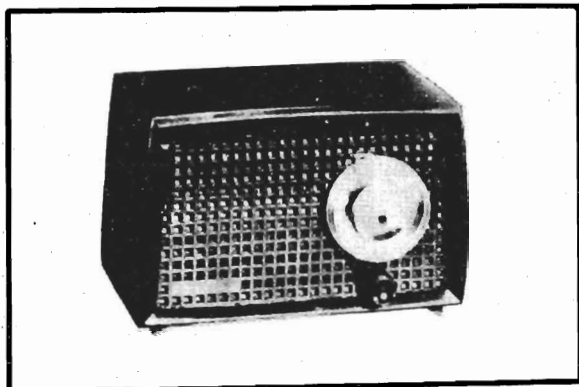

ELECTRICAL SPECIFICATIONS

POWER SUPPLY - - 115 Volts, either DC or
50 to 60 cycles AC

FREQUENCY RANGE - 540 to 1600 kc

INTERMEDIATE FREQ. - 455 kc

SELECTIVITY - At 1000 kc, 100 kc at
1000 X signal.

SENSITIVITY - 3000 microvolts average
for .05 watts output.

POWER OUTPUT -

Undistorted - 0.9 Watt
Maximum - 1.8 Watts

LOUD SPEAKER - 4 Inch Round P.M.

VOICE COIL IMPEDANCE - 3.2 Ohms at
400 cycles.

REAR OF CHASSIS

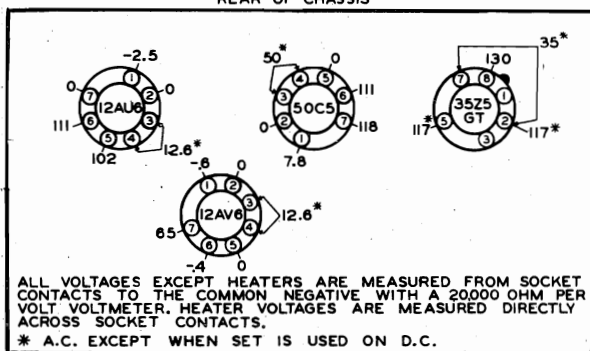

VOLTAGE TABLE
(BOTTOM VIEW OF CHASSIS)

TUBE COMPLEMENT

- 12AU6 - Converter
- 12AV6 - Diode - 1st. Audio
- 50C5 - Power Output
- 35Z5GT - Rectifier

GROUND - No ground connection should be used when operating this receiver. The receiver gets its ground connection through the power line and any external connection to the chassis may cause a short circuit and consequent damage.

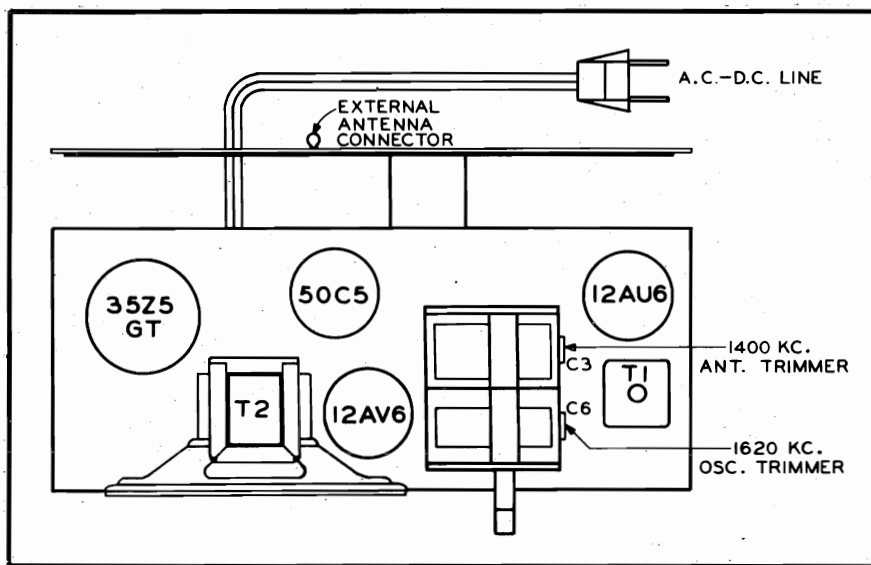

TOP VIEW OF CHASSIS

501A

MODELS 15GSL-1564A, 15GSL-1565A,
15GSL-1566A, 15GSL-1567A

ALIGNMENT PROCEDURE

The signal source must be an accurately calibrated signal generator capable of supplying 455 Kc and up to 1620 Kc signals modulated 30% with a 400-cycle audio signal. Volume control at maximum for all adjustments.

Align for maximum output. Reduce input as needed to keep output near 0.4 volts.

Loop antenna should be connected to receiver and in its proper position when making the adjustments.

SIGNAL GENERATOR				TUNER SETTING	ADJUST FOR MAXIMUM OUTPUT
FREQUENCY	COUPLING CAPACITOR	CONNECTION TO RADIO	GROUND CONNECTION		
455 Kc	.05 Mfd.	Rear stator plates of tuning condenser.	Buss Lead	Any point near center where no interfering signal is received.	Slugs at top and bottom of I.F. Coil T-1
1620 Kc	.05 Mfd.	Rear stator plates of tuning condenser.	Buss Lead	Exactly 1620 Kc.	Oscillator trimmer of Gang. (C6)
1400 Kc	--	Lay Generator lead near back of cabinet	Buss Lead	Exactly 1400 Kc.	Antenna trimmer of Gang. (C3)

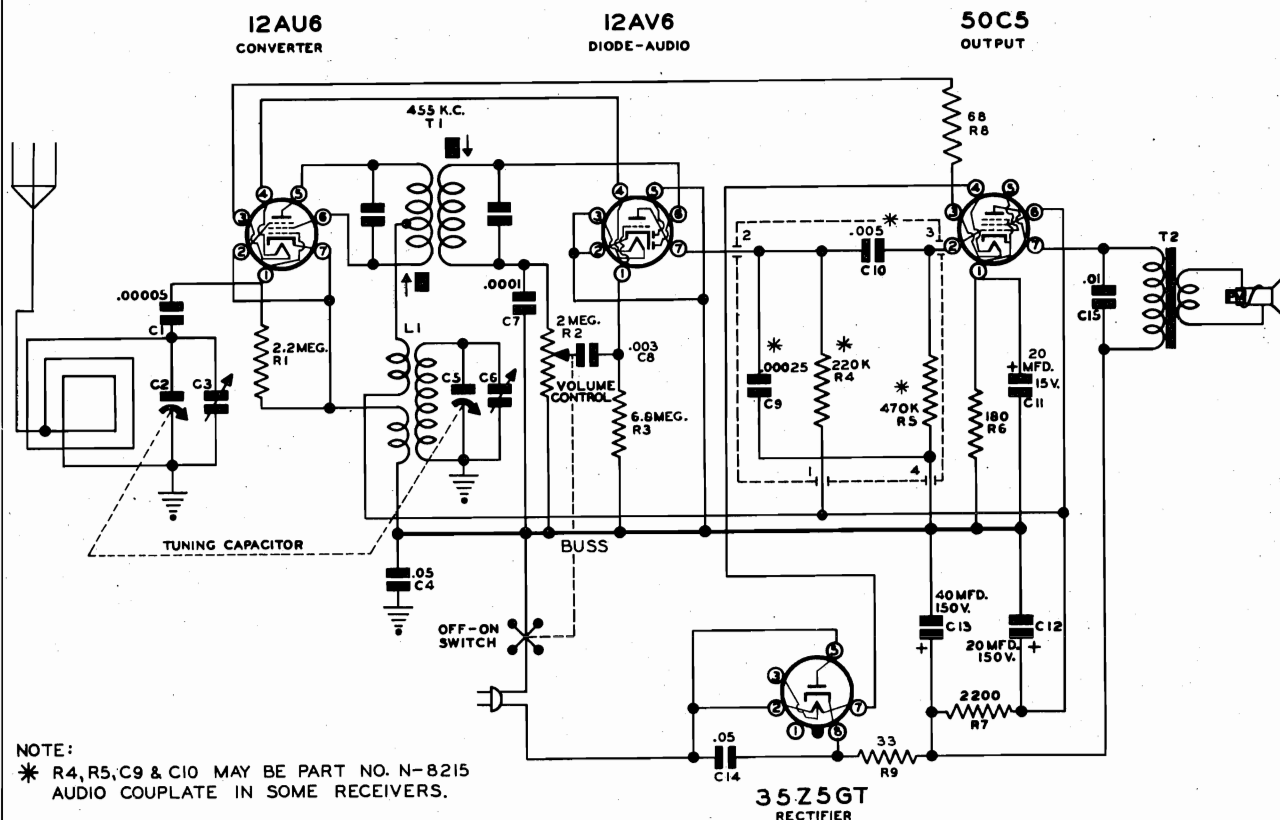

MODELS 15GSL-1564A, 15GSL-1565A,
15GSL-1566A, 15GSL-1567A

HOW TO ORDER PARTS - Should it be necessary to write us or to order any repair parts, it is important that the complete model number which appears on the cabinet back of this

receiver be specified. Repair parts should be ordered from your nearest Wards Retail Store, Catalog Order Office or Mail Order House.

PARTS LIST

REF. NO.	PART NO.	DESCRIPTION	SELLING PRICE
CONDENSERS			
C1	N-6385	Ceramic 50 MMFD. 500 Volts 10%	\$.16
C2, C5	N-7141	Gang Tuning Condenser	1.70
	N-8551	Gang Tuning Condenser B receivers.	
C3, C6		Trimmers on Gang	
C4	N-1345	Paper .05 MFD. 200 Volts16
C7	N-6015	Ceramic 100 MMFD. 500 Volts 20%16
C8	N-2063	Paper .003 MFD. 600 Volts16
* C9	N-6488	Ceramic 250 MMFD. 500 Volts 20%16
* C10	N-4894	Paper .005 MFD. 600 Volts16
C11)		(20 MFD. 15 Volts)	
C12)	N-8442	Electrolytic (20 MFD. 150 Volts)	1.20
C13)		(40 MFD. 150 Volts)	
C14	N-1346	Paper .05 MFD. 400 Volts16
C15	N-1344	Paper .01 MFD. 400 Volts16
RESISTORS			
R1	N-4277	2.2 Megohm, 1/2 Watt, 20%14
R2	N-7142	2 Megohm, Volume Control & Switch94
R3	N-4028	6.8 Megohm, 1/2 Watt, 20%14
* R4	N-4026	220,000 Ohm, 1/2 Watt, 20%14
* R5	N-4027	470,000 Ohm, 1/2 Watt, 20%14
R6	N-4067	180 Ohms, 1/2 Watt, 10%14
R7	N-4896	2,200 Ohms, 1/2 Watt, 10%14
R8	N-6014	68 Ohms, 2 Watts, 10%20
R9	N-4022	33 Ohms, 1/2 Watt, 20%14
TRANSFORMERS & COILS			
T1	N-7694	I. F. Transformer	1.40
T2	Part of N-7824	Output Transformer (Part of Speaker & Output Trans- former Assembly)	
L1	N-7725	Oscillator Coil62
	N-8552	Oscillator Coil B receivers.	
	N-8429	Loop Antenna & Cabinet Back Assembly	.90
MISCELLANEOUS ELECTRICAL PARTS			
	N-7824	Speaker, 4" P.M. with Transformer	4.30
	N-7334	Tube Socket, 7 Pin Miniature10
	N-7515	Tube Socket, Octal10
	N-1090	Line Cord and Plug40
	N-8215	Audio Couplate34
* The resistors (R4 and R5) and condensers (C9 and C10) are replaced by the above part in some receivers.			
MISCELLANEOUS PARTS			
	#342	Cabinet, Plastic - White (Model No. 15GSL-1564 A ₇ B)	3.90
	#343	Cabinet, Plastic - Walnut (Model No. 15GSL-1565 A ₇ B)	3.00
	#344	Cabinet, Plastic - Red (Model No. 15GSL-1566 A ₇ B)	3.90
	#345	Cabinet, Plastic - Light Green (Model No. 15GSL-1567 A ₇ B)	3.90
	#346	Cabinet, Plastic - Dark Green (Model No. 15GSL-1567 A ₇ B)	3.90
	#347	Cabinet, Plastic - Gray (Model No. 15GSL-1567 A ₇ B)	3.90
	N-8431	Knob, Volume Control - White10
	N-8432	Knob, Volume Control - Walnut10
	N-8433	Knob, Volume Control - Red10
	N-8434	Knob, Volume Control - Light Green10
	N-8446	Knob, Volume Control - Dark Green10
	N-8447	Knob, Volume Control - Gray10
	N-8430	Tuning Knob36
	N-8448	Dial Scale - White on Blue-Green Background12
	N-8435	Dial Scale - Maroon on Gold Background12
	N-8436	Dial Scale - Black on White Background12
	N-8437	Dial Scale - Maroon on Chartreuse Background12
	N-8438	Dial Scale - White on Light Green Background12
	N-8449	Dial Scale - White on Red Background12

IMPORTANT: All prices in this literature are subject to change without notice and are subject to an additional charge to cover any applicable sales tax, use, occupation, or other tax affecting our purchase or sale of merchandise.

MODELS 15WG-1545A,
15WG-1546A

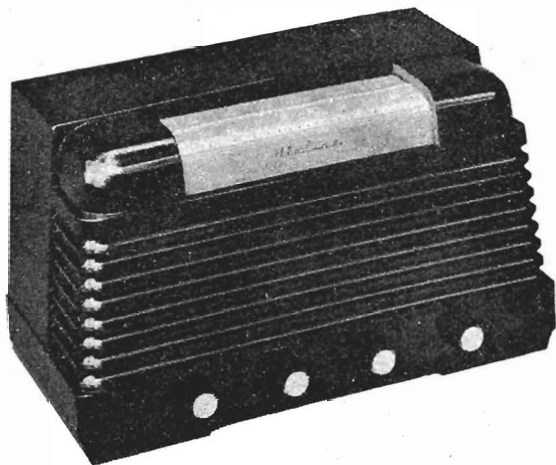

GENERAL DESCRIPTION

This is a two band, seven tube (plus rectifier tube) AM and FM receiver. Controls are provided at the front of the cabinet for tuning, volume, tone and band or phono selection. A phono input socket is provided at the rear of the receiver to which a record player may be connected. The I-F stages use high gain miniature type tubes. Air Wave Aerials are provided for the FM and Broadcast bands. Features include, a grounded grid R-F amplifier stage on the FM band, compensator circuits to prevent oscillator drift, automatic volume control, beam power output stage, PM dynamic loud speaker and an electrostatic shield in the power transformer to reduce power line noise.

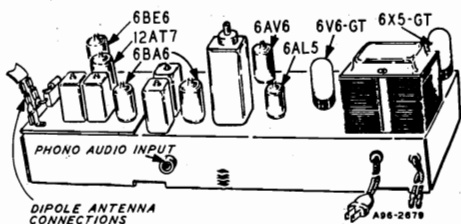

ELECTRICAL SPECIFICATIONS

- Power Supply..... 105-125 volts AC 50-60 cycles, 40 watts.
- Frequency Ranges..... Broadcast 540-1600 KC
Frequency Modulation 88-108 MC
- Intermediate Frequency... AM—455 KC
FM—10.7 MC
- Selectivity..... AM—45 KC broad at 1000 times signal, measured at 1000 KC
I.F. FM—200 KC broad at 2 times down
I.F. FM—950 KC broad at 200 times down
- AM Sensitivity.....(For .5 watt output with external antenna) 25 microvolts average
- FM Sensitivity.....(For .5 watt output) 25 microvolts average
- Power Output..... 1.9 watts maximum
0.8 watts 10% distortion
- Loud Speaker..... 5" PM Dynamic
- Voice Coil Impedance..... 3.2 ohms 400 cycles
- Tube and Dial Lamp Complement**
 - 1 12AT7 R-F Amplifier & Mixer
 - 1 6BE6 AM Converter & FM Osc.
 - 1 6BA6 1st I-F Amplifier
 - 1 6BA6 2nd I-F Amplifier
 - 1 6AL5 FM Discriminator
 - 1 6AV6 Audio Amplifier, AM 2nd Detector and AVC
 - 1 6V6GT Audio Output
 - 1 6X5GT Rectifier
 - 2 No. 47 Dial Lamps

**DRIVE CORD REPLACEMENT
DIAL POINTER CORD**

Use a new 10X80 drive cord assembly or a new length of cord 52 inches long for the installation. Install the cord as shown in the illustration, winding three turns counter-clockwise around the drive shaft with the turns progressing toward the chassis. After completing the installation rotate the drive shaft a few turns to take up the slack in the cord.

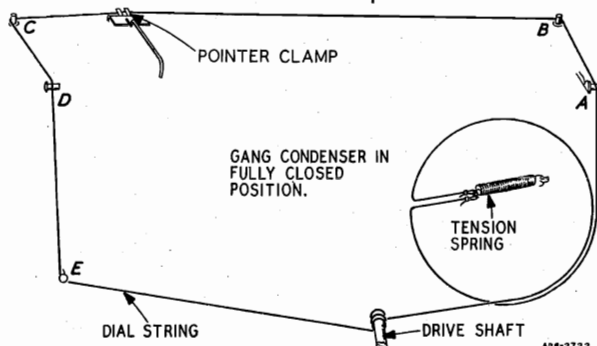
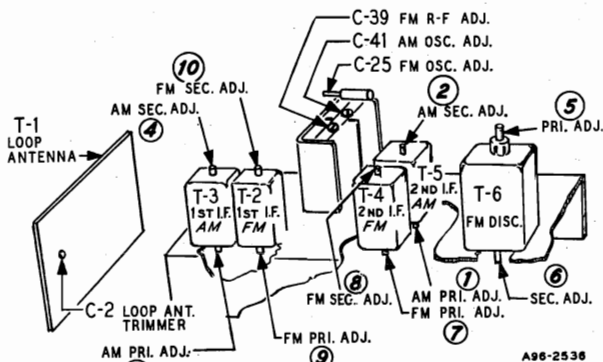

500A

A96-2536

A96-2722

ALIGNMENT PROCEDURES
AM STAGES

The following is required for aligning:
An All Wave Signal Generator Which Will Provide an Accurately Calibrated Signal at the Test Frequencies as Listed.
Output Indicating Meter, Non-Metallic Screwdriver, Dummy Antennas — .1 mf, and 50 mmf.

Volume Control Maximum all Adjustments.
Connect Radio Chassis to Ground Post of Signal Generator with a Short Heavy Lead.
Allow Chassis and Signal Generator to "Heat Up" for Several Minutes.

SIGNAL GENERATOR						
FREQUENCY SETTING	CONNECT GENERATOR OUTPUT TO	THROUGH DUMMY ANTENNA	CONNECT GROUND TO	GANG CONDENSER SETTING	ADJUST	ADJUST FOR
455 KC	Control Grid 1st 6BA6 Pin No. 1	.1 mf	Chassis Base	Rotor Fully Open	2nd I.F. Pri. (1) and Sec. (2)	Maximum Output
455 KC	Control Grid 6BE6 Pin No. 7 1st Det.	.1 mf	Chassis Base	Rotor Fully Open	1st I.F. Pri. (3) and Sec. (4)	Maximum Output
455 KC	Control Grid 6BE6 Pin No. 7	.1 mf	Chassis Base	Rotor Fully Open	2nd I-F Pri. (1) and Sec. (2)	Maximum Output
1620 KC	Control Grid 6BE6 Pin No. 7	.1 mf	Chassis Base	Rotor Fully Open	Oscillator C-41	Maximum Output
1400 KC	External Antenna Terminal	50 mmf	Chassis Base	Turn Rotor to Max. Output. Set Pointer to 1400 KC See Note A	Antenna C-2	Maximum Output

NOTE A—If the pointer is not at 1400 KC on the dial, reset pointer to the 1400 KC mark on the dial scale.

FM STAGES

The following is required for aligning:
An accurately calibrated signal generator providing unmodulated signals at the test frequencies listed below.
Non-metallic screwdriver.
Dummy Antennas and I-F Loading Resistor—2500 mmf, 300 ohms

Zero center scale DC vacuum tube voltmeter having a range of approximately 3 volts.
(If a zero center scale meter is not available, a standard scale vacuum tube voltmeter may be used by reversing the meter connections for negative readings).
Allow chassis and signal generator to "Heat Up" for several minutes.

SIGNAL GENERATOR							
	FREQUENCY SETTING	CONNECT GENERATOR OUTPUT TO	THROUGH DUMMY ANTENNA	BAND SWITCH SETTING	GANG CONDENSER SETTING	ADJUST	ADJUST FOR
Discriminator	10.7 MC	6BA6 2nd I-F Pin 1 and Chassis	2500 mmf	FM	Rotor Fully Open	Disc. Pri. (5) Note A	Maximum Deflection
	10.7 MC	6BA6 2nd I-F Pin 1 and Chassis	2500 mmf	FM	Rotor Fully Open	Disc. Sec. (6) Note B	
I-F	10.7 MC Note C	6BA6 1st I-F Pin 1 and Chassis	2500 mmf	FM	Rotor Fully Open	2nd I-F Pri. (7) Sec. (8) Note D	Maximum Deflection
Discriminator	10.7 MC	6BA6 1st I-F Pin 1 and Chassis	2500 mmf	FM	Rotor Fully Open	Disc. Pri. (5) Note D	Maximum Deflection
I-F	10.7 MC	Junction C-32A & B (Dual 100 mmf cond.) And chassis	2500 mmf	FM	Rotor Fully Open	1st I-F Pri. (9) & Sec. (10) 2nd I-F Pri. (7) & Sec. (8) Disc. Pri. (5) In Order Shown Note D	Maximum Deflection
	10.7 MC	Same as above	2500 mmf	FM	Rotor Fully Open	Disc. Sec. (6) Note B	

RECHECK I-F ADJUSTMENTS IN ORDER GIVEN

Oscillator	108.5	Disconnect built-in dipole antenna and connect generator to dipole terminals with resistor in series.	300 ohms	FM	Rotor Fully Open	Osc. C-25	Deflection Maximum
Antenna	104.5	Same as above	300 ohms	FM	Tune rotor for max. AVC voltage	Ant. C-39	Maximum Deflection

RECHECK ANTENNA & OSC. ADJUSTMENTS IN ORDER GIVEN

FM ALIGNMENT NOTES

NOTE A—The zero center scale DC vacuum tube voltmeter is to be connected between chassis ground and the AVC line. A signal of .1 volt must be fed into the receiver for this adjustment.
Note output voltage on the zero center DC vacuum tube voltmeter.
NOTE B—Disconnect zero center DC vacuum tube voltmeter from AVC and connect it at the audio takeoff point at the

27 K ohm resistor (R-10) and its junction with the terminal strip. Adjust for zero voltage indication.
NOTE C—AM I-F coils must be aligned before attempting to align the FM I-F coils.
NOTE D—Connect zero center DC vacuum tube voltmeter as in Note A. Adjust input to give same output on the zero center DC vacuum tube voltmeter as in Note A.

MODELS 15WG-1545A,
15WG-1546A

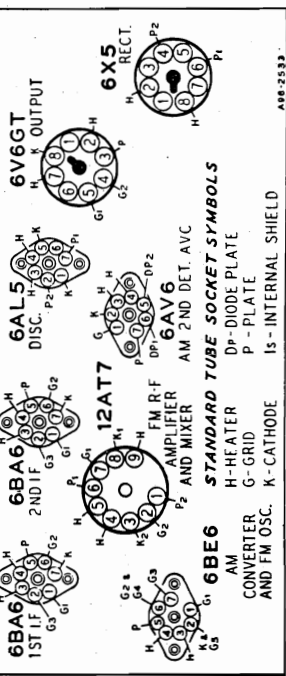
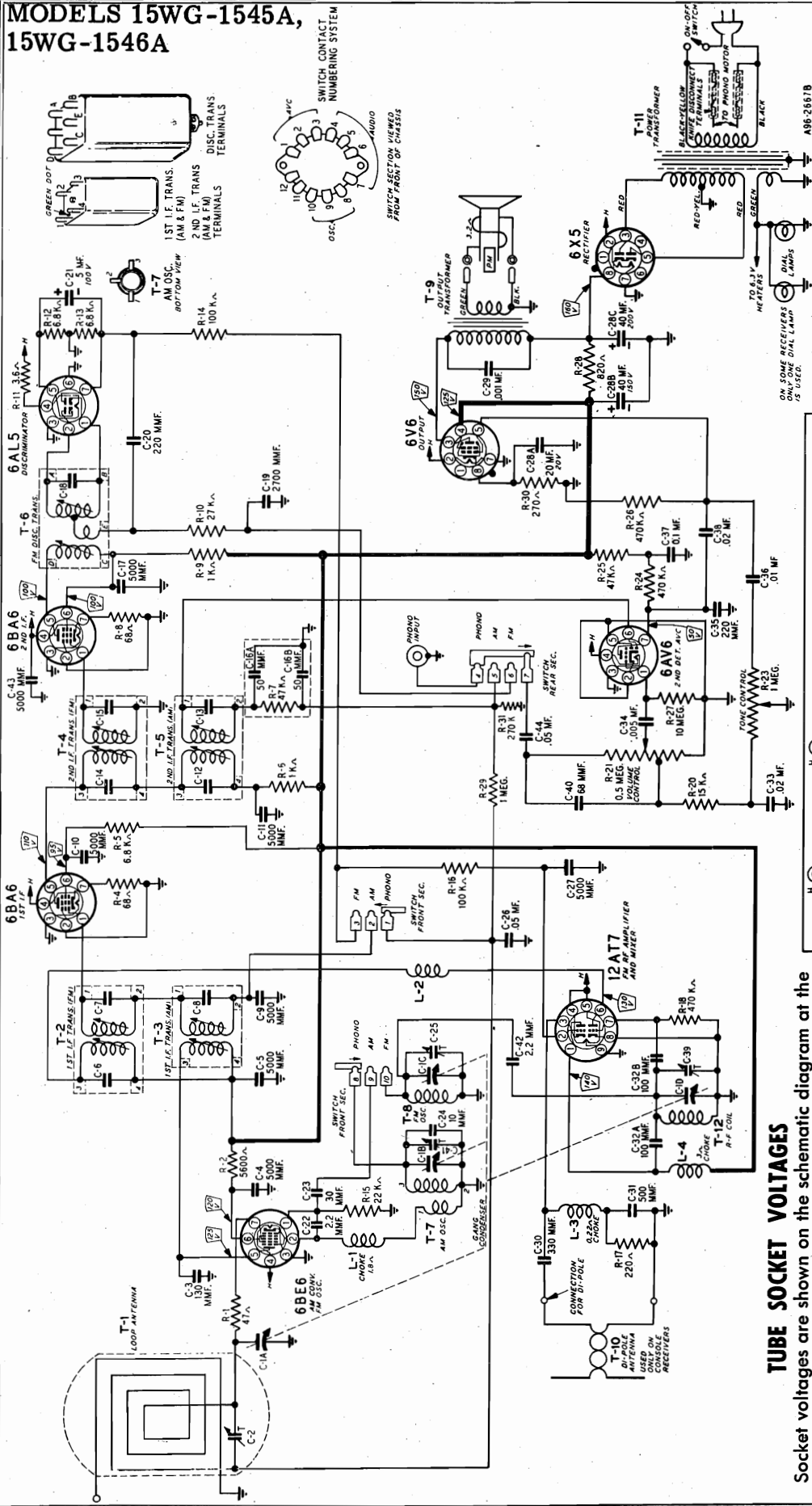

TUBE SOCKET VOLTAGES

Socket voltages are shown on the schematic diagram at the tube socket terminals. All voltages are between the socket terminal and chassis ground. Plate, screen and cathode voltages were taken with a 1000 ohm-per-volt meter with a 300 volt scale used for plate and screen voltages. Audio grid voltages were read with a vacuum tube volt-meter. Conditions of measurement are:

- Line voltage117 Volts AC
- Signal InputNone
- A variation of $\pm 10\%$ is usually permissible.

Phono Motor Connections Not
Used in Mantel Receivers.

ON SOME RECEIVERS
ONLY ONE DIAL LIGHT
IS USED.

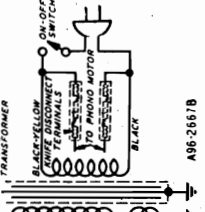
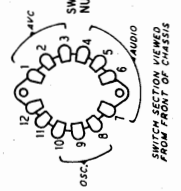
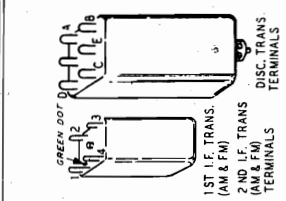

MODELS 15WG-1545A,
15WG-1546A

PARTS INFORMATION

HOW TO ORDER REPAIR PARTS

Repair Parts may be ordered from your nearest Wards Retail Store, Catalog Order Office, or Mail Order House. To have your order filled promptly and correctly, please furnish the following information:

1. MODEL NUMBER which appears on model label on the rear of the chassis.
2. PART NUMBER AND NAME OF PART.

PARTS LIST

Use only genuine factory tested parts to insure service jobs you can depend on and to obtain original set performance
Prices subject to change without notice.

Ref. No.	Part No.	Description	Qty. Used in Set	Selling Price
CAPACITORS				
C-1	14A209	Gang Condenser Assembly	1	3.50
C-2	17A256	2-24 mmf Trimmer	1	.16
C-3	47X559	130 mmf Ceramic	1	.16
C-4				
C-5				
C-9				
C-10	47X507	5000 mmf Ceramic	8	.18
C-11				
C-17				
C-27				
C-43				
C-6		Part of T-2 (1st I-F Trans. FM)		
C-7				
C-8		Part of T-3 (1st I-F Trans. AM)		
C-12		Part of T-5 (2nd I-F Trans. AM)		
C-13				
C-14		Part of T-4 (2nd I-F Trans. FM)		
C-15				
C-16A	47X112	50-50 mmf Dual Mica	1	.12
C-16B				
C-18		Part of T-6 (Discriminator Trans.)		
C-19	47X492	2700 mmf Molded Mica	1	.34
C-20	47X468	220 mmf Ceramic	1	.18
C-21	45X361	5 mf 100 V Dry Electrolytic	1	.60
C-22	47X557	2.2 mmf Ceramic	2	.06
C-42				
C-23	47X558	30 mmf Ceramic	1	.16
C-24	47X523	10 mmf Ceramic	1	.16
C-25	17A255	1-8 mmf Trimmer	1	.30
C-26	866503	.05 mf 200 V Tubular	2	.16
C-44				
C-28A		20 mf 20 V		
C-28B	45X360	40 mf 150 V Dry Electrolytic	1	1.56
C-28C		40 mf 200 V		
C-29	H66102	.001 mf 800 V Tubular	1	.10
C-30	47X470	330 mmf Molded Mica	1	.18
C-31	47X508	500 mmf Ceramic	1	.16
C-32A	76X4	100 mmf Dual Ceramic	1	.24
C-32B				
C-33	866203	.02 mf 200 V Tubular	1	.12
C-34	D66502	.005 mf 400 V Tubular	1	.12
C-35		Part of 76X5 (See Miscellaneous)		
C-38				
C-36	866103	.01 mf 200 V Tubular	1	.12
C-37	D66104	.1 mf 400 V Tubular	1	.18
C-39		Part of C-1 (Gang Condenser)		
C-41				
C-40	47X471	68 mmf Ceramic	1	.18
RESISTORS				
R-1	885470	47 0.5 Carbon	1	.06
R-2	885562	5600 0.5 Carbon	1	.06
R-4	884680	68 0.5 Carbon	2	.08
R-8				
R-5				
R-12	884682	6800 0.5 Carbon	3	.08
R-13				
R-6	885102	1000 0.5 Carbon	2	.06
R-9				
R-7	885473	47 K 0.5 Carbon	2	.06
R-25				
R-10	885273	27 K 0.5 Carbon	1	.06
R-11	43X233	3.6 0.5 Wirewound	1	.14
R-14	885104	100 K 0.5 Carbon	2	.06
R-16				
R-15	885223	22 K 0.5 Carbon	1	.06

Ref. No.	Part No.	Description	Qty. Used in Set	Selling Price
R-17	884221	220 0.5 Carbon	1	.08
R-18	885474	470 K 0.5 Carbon	1	.06
R-20	885153	15 K 0.5 Carbon	1	.06
R-21	36X381	.5 meg. Volume Control & Switch	1	.64
R-23	40X343	1.0 meg. Tone Control	1	.52
R-24		Part of 76X5 (See Miscellaneous)		
R-26				
R-27	885106	10 meg. 0.5 Carbon	1	.06
R-28	DB4821	820 0.5 Carbon	1	.16
R-29	885105	1 meg. 0.5 Carbon	1	.06
R-30	884271	270 0.5 Carbon	1	.08
R-31	884274	270 K 0.5 Carbon	1	.08
TRANSFORMERS AND COILS				
L-1	35A5	Insulated Choke	1	.16
L-2	9A2103	Parasitic Choke Assembly	1	.16
L-3	35A9	Insulated Choke	1	.16
L-4	35A8	Insulated Choke	1	.16
T-1	9A2229	"B" Range Loop Antenna	1	1.46
T-2	9A2060	1st I-F Trans. (FM)	1	.94
T-3	9A2062	1st I-F Trans. (AM)	1	.90
T-4	9A2061	2nd I-F Trans. (FM)	1	.94
T-5	9A2063	2nd I-F Trans. (AM)	1	.94
T-6	9A2161	Discriminator Transformer	1	1.66
T-7	9A2065	Oscillator Coil (AM)	1	.58
T-8	9A2067	Oscillator Coil (FM)	1	.10
T-9	51X155	Output Transformer	1	1.40
T-11	53X322	Power Transformer	1	5.52
T-12	9A2066	Antenna Coil (FM)	1	.12
MISCELLANEOUS				
	12A507	5" P.M. Speaker	1	3.10
	3A435	Tube Socket—Octal (8 prong) Molded	2	.10
	3A426	Tube Socket	4	.12
	3A427	Tube Socket	1	.16
	3A443	Tube Socket (12AT7)	1	.24
	3A305	Phono Socket—Single Pin Tip	1	.06
	2A395	Band Change Switch	1	.78
	13X546	Line Cord and Plug Assembly	1	.54
	10A760	Knob (Ivory)	4	.16
	10A761	Knob (Brown)	4	.16
	76X5	Resistor Capacitor Comb.	1	.40
	55X318	Cabinet, Brown (1545)	1	5.64
	55X418	Cabinet, Ivory (1546)	1	7.14
DIAL AND DRIVE ASSEMBLY				
	58X754	Dial Glass	1	1.72
	15X269	Pointer	1	.12
	7A103	Pilot Light Socket Assembly	1	.24
	7A103	No. 47 Pilot Light Bulb	2	.16
	7A237	Pilot Light Socket Assembly	1	.24
	26X510	Drive Shaft	1	.22
	28X113	Drive Cord Tension Spring	1	.02
	10X80	Drive Cord Assembly	1	.12
	19X192	"C" Washer (Mtg. drive Shaft)	2	.02
	6X66	Rubber Grommet (Mtg. gang cond.)	3	.04

MODELS 15WG-2761A, 15WG-2765B, 15WG-2765C, 25WG-2765D



GENERAL DESCRIPTION

This is a two band, nine tube (plus rectifier tube) AM and FM receiver with an automatic record changer. The I-F stages use high gain miniature type tubes. Built-in Air Wave Aerials are provided for the FM and Broadcast bands. Features include, compensator circuits to prevent oscillator drift, automatic volume control, push-pull pentode power output stage, PM dynamic loud speaker and an electrostatic shield in the power transformer to reduce power line noise.

The receiver and record changer are housed in a console combination cabinet with controls provided for tuning, volume, tone and band or phono selection.

DRIVE CORD REPLACEMENT

Use a new 10X54 drive cord assembly or a new length of cord 48 inches long for the installation, winding three turns clockwise around the drive shaft with the turns progressing away from the chassis. After completing the installation, rotate the drive shaft a few turns to take up the slack in the cord.

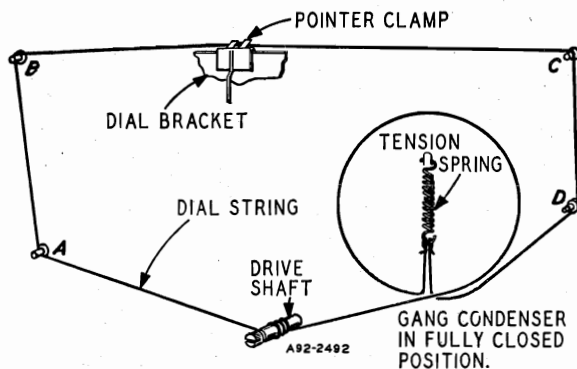

494C

ELECTRICAL SPECIFICATIONS

- Power Supply 105-125 volts AC 60 cycles, 80 watts, 100 watts with record changer
- Frequency Ranges . . . Broadcast 540-1600 KC
Frequency Modulation 88-108 MC
- Intermediate Frequency . . AM-455 KC
FM-10.7 MC
- Selectivity AM-43 KC broad at 1000 times signal, measured at 1000 KC
I.F. FM-200 KC broad at 2 times down
I.F. FM-760 KC broad at 200 times down
- AM Sensitivity (For .5 watt output with external antenna)
10 microvolts average
- FM Sensitivity (For .5 watt output)
30 microvolts average
- Power Output 8.5 watts maximum
6.0 watts 10% distortion
- Loud Speaker 12" PM Dynamic
- Voice Coil Impedance . 3.2 ohms 400 cycles

Tube and Dial Lamp Complement

- 1 6BA6 AM-FM R-F Amplifier
- 1 12AT7 FM & AM Osc. & Mixer
- 1 6BA6 FM-AM 1st I-F Amplifier
- 1 6BA6 FM 2nd I-F Amplifier
- 1 6AL5 FM Detector
- 1 6AV6 Audio Amplifier, AM 2nd Detector and AVC
- 2 6K6-GT Audio Output
- 1 5Y3-GT Rectifier
- 1 6AV6 Phase Inverter
- 2 No. 47 Dial Lamps

MODELS 15WG-2761A,
15WG-2765B, 15WG-
2765C, 25WG-2765D

ALIGNMENT PROCEDURE AM STAGES

The following is required for aligning:
An All Wave Signal Generator Which Will Provide an Accurately
Calibrated Signal at the Test Frequencies as Listed.
Output Indicating Meter, Non-Metallic Screwdriver, Dummy Antennas
—.1 mf, 200 mmf.

Volume Control—Maximum all Adjustments
Connect Radio Chassis to Ground Post of Signal Generator with a
Short Heavy Lead.
Allow Chassis and Signal Generator to "Heat Up" for Several
Minutes.

SIGNAL GENERATOR		CONNECT GENERATOR OUTPUT TO	THROUGH DUMMY ANTENNA	BAND SWITCH SETTING	GANG CONDENSER SETTING	ADJUST	ADJUST FOR
I-F	455 kc	12AT7 Pin 7 and Chassis	.1 mf	Broadcast	Rotor Fully Open	2nd I-F Pri. & Sec. ① & ② 1st I-F Pri. & Sec. ③ & ④	Maximum Output
Broadcast	1620 kc	External ant. term.	200 mmf	Broadcast	Rotor Fully Open	Broadcast Oscillator C-33	
	1400 kc	External ant. term.	200 mmf	Broadcast	Turn Rotor to Max. Output Set pointer to	Broadcast Interstage C-29	
	1400 kc	External ant. term.	200 mmf	Broadcast	1400 kc See Note A	Loop Antenna C-48	

Note A—If the pointer is not at 1400 KC on dial, reset pointer at the 1400 KC mark on the dial scale.

FM STAGES

The following equipment is required for aligning:
An accurately calibrated signal generator providing unmodulated
signals at the test frequencies listed below.
Non-metallic screwdriver.
Dummy Antennas and I-F Loading Resistor—.01 mf, 300 ohms
and 1000 ohms.

Zero center scale DC vacuum tube voltmeter having a range of
approximately 3 volts.
(If a zero center scale meter is not available, a standard scale
vacuum tube voltmeter may be used by reversing the meter connec-
tions for negative readings.)
Allow chassis and signal generator to warm up for several minutes.

SIGNAL GENERATOR		CONNECT GENERATOR OUTPUT TO	THROUGH DUMMY ANTENNA	BAND SWITCH SETTING	GANG CONDENSER SETTING	ADJUST	ADJUST FOR
Discrim- inator	10.7 MC Note B	6BA6 2nd I-F Pin 1 and Chassis	.01 mf	FM	Rotor Fully Open	Disc. Pri. ⑤ Note A	Maximum Deflection
	10.7 MC Note B	6BA6 2nd I-F Pin 1 and Chassis	.01 mf	FM	Rotor Fully Open	Disc. Sec. ⑥ Note C	Zero Center
I-F	10.7 MC Note F	6BA6 1st I-F Pin 1 and Chassis	.01 mf	FM	Rotor Fully Open	2nd I-F Pri. Note A and D ⑦ 2nd I-F Sec. Note A and E ⑧	Maximum Deflection
Discrim- inator	10.7 MC Note F	6BA6 1st I-F Pin 1 and Chassis	.01 mf	FM	Rotor Fully Open	Disc. Pri. ⑤ Note A	Maximum Deflection
	10.7 MC Note F	6BA6 1st I-F Pin 1 and Chassis	.01 mf	FM	Rotor Fully Open	Disc. Sec. ⑥ Note C	Zero Center
	10.7 MC Note F	FM-RF Gang Condenser terminal	.01 mf	FM	Rotor Fully Open	1st I-F Pri. ⑨ 1st I-F Sec. ⑩ Notes A, D & E	Maximum Deflection

Recheck I-F Adjustments in order given

R-F & Osc.	108.4 Note H	Disconnect dipole and connect generator to di- pole terminals with re- sistor in series	300 ohms	FM	Rotor Fully Open	Oscillator C-35 Note G	Maximum Deflection
	104.5	Disconnect dipole and connect generator to di- pole terminals with re- sistor in series	300 ohms	FM	Tune Rotor for Max. AVC voltage	FM Interstage C-32	Maximum Deflection
	104.5	Disconnect dipole and connect generator to di- pole terminals with re- sistor in series	300 ohms	FM	Tune Rotor for Max. AVC voltage	Ant. C-47	Maximum Deflection

Recheck R-F and Osc. Adjustments in order given

NOTE A—Test Equipment connections are as given in the table. The
zero center scale DC vacuum tube voltmeter is to be con-
nected between chassis ground and the AVC line at the
junction of resistor R-22 and condenser C-18 for all ad-
justments except the discriminator secondary adjustment, for
which See Note C.

NOTE B—A signal of .1 volt must be fed into the receiver for this
adjustment.

NOTE C—Disconnect zero center DC vacuum tube voltmeter from
AVC and connect to junction of R-18 and C-62. Adjust
for zero voltage indication.

NOTE D—Before adjusting Pri. core connect 1000 ohm load resistor
across the 2nd I.F. secondary terminals. Input may have
to be increased to .1 volt if receiver is badly mis-aligned.

NOTE E—Disconnect 1000 ohm load resistor from secondary ter-
minals and connect across the 2nd I.F. primary terminals.
Input may have to be increased to .1 volt if receiver is
badly mis-aligned.

NOTE F—Input can be reduced to 10,000 microvolts.

NOTE G—Oscillator frequency above signal frequency.

NOTE H—Remove the 1000 ohm load resistor before attempting to
check the R-F and oscillator adjustments.

MODELS 15WG-2761A,
15WG-2765B, 15WG-
2765C, 25WG-2765D

PARTS INFORMATION

HOW TO ORDER REPAIR PARTS

Repair Parts may be ordered from your nearest Wards Retail Store, Catalog Order Office, or Mail Order House. To have your order filled promptly and correctly, please furnish the following information:

1. MODEL NUMBER which appears on the model label on the rear of the chassis.
2. PART NUMBER AND NAME OF PART.

PARTS LIST

Use only genuine factory tested parts to insure service jobs you can depend on and to obtain original set performance. Prices subject to change without notice.

Ref. No.	Part No.	Description	Qty. Used in Set	Selling Price								
CAPACITORS												
C-1	14A207	Gang Condenser	1	\$ 5.26								
C-2 } C-3 } C-7 } C-9 } C-13 } C-16 } C-17 } C-18 } C-19 } C-27 } C-42 }	47X507	5000 mmf Ceramic.....	11	.18								
C-4					47X497	100 mmf Ceramic.....	1	.14				
C-5					47X499	47 mmf Ceramic.....	1	.18				
C-8					47X498	47 mmf Ceramic.....	1	.16				
C-10 } C-65 }					Part of T-1 1st I-F (FM)							
C-11 } C-28 }					47X550	100 mmf Ceramic.....	2	.16				
C-15					Part of T-3 2nd I-F (FM)							
C-21					Part of T-5 Discriminator							
C-22 } C-24 } C-31 } C-51 }					47X501	68 mmf Ceramic.....	4	.12				
C-23									45X361	5 mf 100 V Dry Electrolytic	1	.60
C-25 } C-26 } C-45 }									47X496	500 mmf Ceramic.....	3	.16
C-29 } C-32 } C-33 } C-47 }	Part of Gang Condenser											
C-30	47X552	15 mmf Ceramic.....	1	.14								
C-34 } C-46 }	47X516	20 mmf Ceramic.....	2	.16								
C-35					26A489	1-8 mmf Trimmer.....	1	.30				
C-36 } C-64 }	47X549	5 mmf Ceramic.....	2	.22								
C-37 } C-65 }					F66403	.04 mf 600 V Tubular.....	2	.16				
C-38 } C-39 }	Part of T-2 1st I-F (AM)											
C-40	B66503	.05 mf 200 V Tubular.....	1	.16								
C-41 } C-43 }	Part of T-4 2nd I-F (AM)											
C-44A } C-44B }	47X112	50-50 mmf Dual Mica....	1	.12								

Ref. No.	Part No.	Description	Qty. Used in Set	Selling Price				
CAPACITORS—Cont.								
C-48	Part of T-7 (Loop Antenna)							
C-50A } C-50B } C-50C }	45X374	40 mf 450 V Dry Electrolytic	1	2.22				
C-52		F66103	.01 mf 600 V Tubular.....	1	.10			
C-53		47X468	220 mmf Ceramic.....	1	.18			
C-54 } C-59 }	F66203	.02 mf 600 V Tubular.....	2	.16				
C-55 } C-60 }					F66102	.001 mf 600 V Tubular.....	2	.12
C-56	B66203	.02 mf 200 V Tubular.....	1	.12				
C-57	F66602	.006 mf 600 V Tubular.....	1	.12				
C-58	B66502	.005 mf 200 V Tubular.....	1	.12				
C-61	47X471	68 mmf Ceramic.....	1	.18				
C-62	47X492	2700 mmf Molded Mica..	1	.34				
C-63	46X328	.01 mf 120 V Tubular.....	1	.12				
RESISTORS								
		Ohms Watts						
R-1 } R-10 } R-22 }	B85105	1 meg. 0.5 Carbon.....	3	.06				
R-2 } R-12 } R-15 }					B83680	68 0.5 Carbon.....	3	.10
R-3 } R-11 }								
R-4 } R-6 } R-8 } R-13 }	B84102	1000 0.5 Carbon.....	4	.08				
R-5					B85104	100K 0.5 Carbon.....	1	.06
R-7					B84103	10K 0.5 Carbon.....	1	.08
R-9					B85225	2.2 meg. 0.5 Carbon.....	1	.06
R-14	B85473	47K 0.5 Carbon.....	1	.06				
R-16	C84393	39K 1.0 Carbon.....	1	.10				
R-17	B85222	2200 0.5 Carbon.....	1	.06				
R-18	B84273	27K 0.5 Carbon.....	1	.08				
R-19	43X233	3.6 0.5 Wirewound..	1	.14				
R-20 } R-21 }	B83682	6800 0.5 Carbon.....	2	.10				
R-23					43X242	1400 5.0 Wirewound...	1	.40
R-25	36X372	0.5 meg. Volume Control	1	.74				
R-26	B85153	15K 0.5 Carbon.....	1	.06				
R-27	40X285	3 meg. Tone Control..	1	.48				

MODELS 15WG-2761A, 15WG-2765B, 15WG-2765C, 25WG-2765D

RESISTORS—Cont.

R-28 } R-33 }	B85106	10 meg.	0.5	Carbon.....	2	.06
R-29 } R-34 }	B85274	270K	0.5	Carbon.....	2	.06
R-30	D83561	560	2.0	Carbon.....	1	.20
R-31 } R-35 } R-38 }	B85474	470K	0.5	Carbon.....	3	.06
R-32	B84822	8200	0.5	Carbon.....	1	.08
R-36	B84682	6800	0.5	Carbon.....	1	.08
R-37	B84562	5600	0.5	Carbon.....	1	.08
R-39	B84221	220	0.5	Carbon.....	1	.08

TRANSFORMERS AND COILS

L-2	9A2025	Interstage Coil (AM)	1	1.32
L-3	9A2024	Interstage Coil (FM)	1	.06
L-4	9A2022	Oscillator Coil (AM)	1	.10
L-5	35A5	Insulated Choke	1	.16
L-6	9A1881	Filament Choke	1	.48
L-7	9A2023	Oscillator Coil (FM)	1	.10
L-8	35A7	Mixer Choke (FM)	1	.20
L-9	9A2027	Antenna Coil (FM)	1	.64
T-1	9A2043	1st I-F Trans. (FM)	1	1.30
T-2	9A2029	1st I-F Trans. (AM)	1	1.20
T-3	9A2030	2nd I-F Trans. (FM)	1	1.12
T-4	9A2042	2nd I-F Trans. (AM)	1	.88
T-5	9A2064	Discriminator Coil	1	1.76
T-6	9A2004	Dipole Antenna	1	.58
T-7	9A2041	"B" Range Loop Antenna	1	1.56
T-8	53X286	Power Transformer	1	8.70
T-9	51X142	Output Transformer	1	1.88

DIAL AND DRIVE ASSEMBLY

58X723	Dial Glass	1	.50
25X1634	Dial Bracket	1	1.06
41X88	Dial Light Reflector	2	.10
15X251	Pointer	1	.10
10X54	Drive Cord Assembly	1	.12
28X113	Drive Cord Spring	1	.02
7A103	No. 47 Pilot Light	2	.16
7A199	Pilot Light Socket Assembly	1	.28
19X192	"C" Washer (mtg. Drive Shaft)	2	.02
26X512	Drive Shaft	1	.30
6X67	Rubber Grommet	4	.02

MISCELLANEOUS

12A502	Speaker 12" P.M.	1	9.22
3A305	Phono Socket—Single Pin Tip	1	.06
3A435	Tube Socket—Octal (8 prong)	3	.10
3A436	Tube Socket—Noval (miniature)	1	.48
32X388	Tube Shield—Noval	1	.40
32X390	Tube Shield (miniature)	1	.06
3A439	Tube Socket (miniature)	6	.10
2A391	Band Change Switch	1	1.80
13X546	Line Cord & Plug Assembly	1	.54
10A713	Knobs (Mah.)	4	.10
4X1049	Escutcheon	1	2.76
10A765	Knobs (Blond.)	4	.16

TYPE V-28A180 RECORD CHANGER PARTS

MODEL 15WG-2761A 15WG-2765C

See Note	Motor Assembly, 60 cycles, 105-125 Volts AC	1	
V-2503B	Pickup Arm	1	1.20
W-R-A1SM-1	Crystal Cartridge & Needles	1	
W-R-13017	Needle, Microgroove (Red)	1	1.66
W-R-13016	Needle, Regular	1	1.66

NOTE — Specify part number stamped on motor assembly.

TYPE V-28A172 RECORD CHANGER PARTS

MODEL 15WG-2765B

See Note	Motor Assembly, 60 cycles, 105-125 Volts AC	1	
V-3429B	Pickup Arm	1	1.62
W-R-AIM	Crystal Cartridge & Needle	1	9.36
W-R-13017	Needle, Microgroove (Red)	1	1.66
W-R-13016	Needle, Regular	1	1.66

NOTE — Specify part number stamped on motor assembly.

TYPE V-28A170 RECORD CHANGER PARTS

MODEL 25WG-2765D

See Note	Motor Assembly, 60 cycles, 105-125 Volts AC	1	
V-2503B	Pickup Arm	1	1.20
P-77	Crystal Cartridge & Needles (Use 60H17)	1	8.50
85-16	Needle, Regular (Use 61H2)	1	.98
85-18	Needle, Microgroove, Red (Use 61H13)	1	1.50

NOTE — Specify part number stamped on motor assembly.

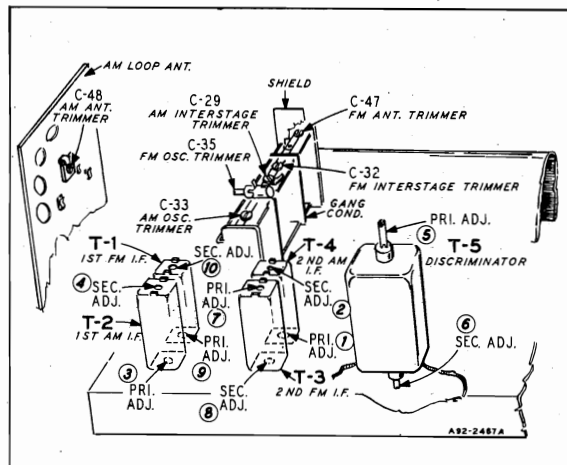

MODELS 25GSL-1560A,
25GSL-1561A

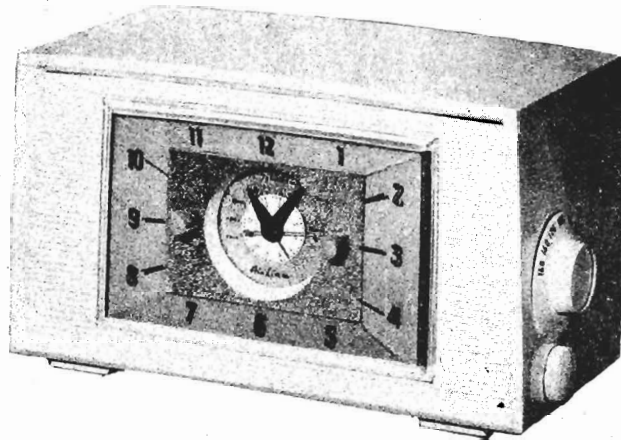

GENERAL DESCRIPTION

ELECTRICAL SPECIFICATIONS

RADIO

Four tubes including tube rectifier.
Built-In loop antenna.
Permanent Magnet Dynamic Speaker.

POWER SUPPLY - 110 to 120 volts 60 cpls.
(Alternating Current)

FREQUENCY RANGE - 540 to 1600 KC

AUTOMATIC CLOCK

Self Starting.
Turns on radio automatically.
Turns on radio, and buzzer alarm sounds
10 minutes later.

INTERMEDIATE FREQ. - 455 KC

POWER OUTPUT - Undistorted - 0.9 Watt
- Minimum - 1.8 Watts

TUBE COMPLEMENT

12AU6	Converter
12AV6	Diode - 1st Audio
50C5	Power Output
35W4	Rectifier

SENSITIVITY - 3000 microvolts average
for .05 watts output

SELECTIVITY - At 1000 KC, 100 KC at
1000 X signal

LOUD SPEAKER - 4 Inch Round P. M.

VOICE COIL IMPEDANCE - 3.2 Ohms at
400 cycles

512A

MODELS 25GSL-1560A,
25GSL-1561A

ALIGNMENT PROCEDURE

The signal source must be an accurately calibrated signal generator capable of supplying 455 Kc an up to 1620 Kc signals modulated 30% with a 400-cycle audio signal.

Volume control at maximum for all adjustments.

Align for maximum output. Reduce input as needed to keep output near 0.4 volts.

Loop antenna should be connected to receiver and in its proper position when making the adjustments.

S I G N A L G E N E R A T O R				TUNER SETTING	ADJUST FOR MAXIMUM OUTPUT
FREQUENCY	COUPLING CAPACITOR	CONNECTION TO RADIO	GROUND CONNECTION		
455 Kc	.05 Mfd.	Rear stator plates of tuning conden- ser.	B Minus Buss Lead	Any point near center where no interfering signal is received.	Slugs at top and bottom of I.F. Coil T-1
1620 Kc	.05 Mfd.	Rear stator plates of tuning conden- ser.	B Minus Buss Lead	Exactly 1620 Kc.	Oscillator trimmer of Gang. (C6)
1400 Kc	--	Lay Generator lead near back of cab- inet	B Minus Buss Lead	Exactly 1400 Kc.	Antenna trimmer of Gang. (C3)

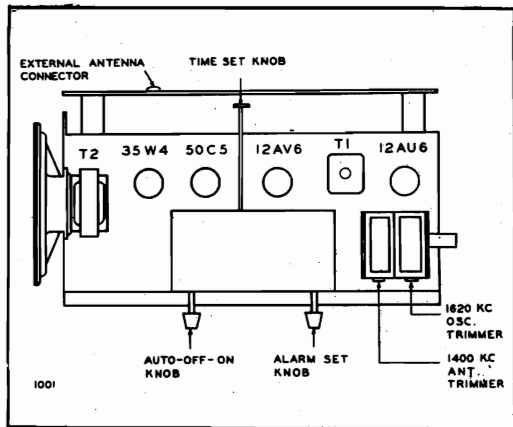

TOP VIEW OF CHASSIS

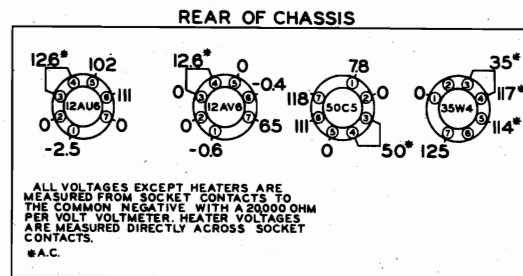

ALL VOLTAGES EXCEPT HEATERS ARE MEASURED FROM SOCKET CONTACTS TO THE COMMON NEGATIVE WITH A 20000 OHM PER VOLT VOLTMETER. HEATER VOLTAGES ARE MEASURED DIRECTLY ACROSS SOCKET CONTACTS.
*A.C.

VOLTAGE TABLE
(BOTTOM VIEW OF CHASSIS)

BOTTOM VIEW OF CHASSIS

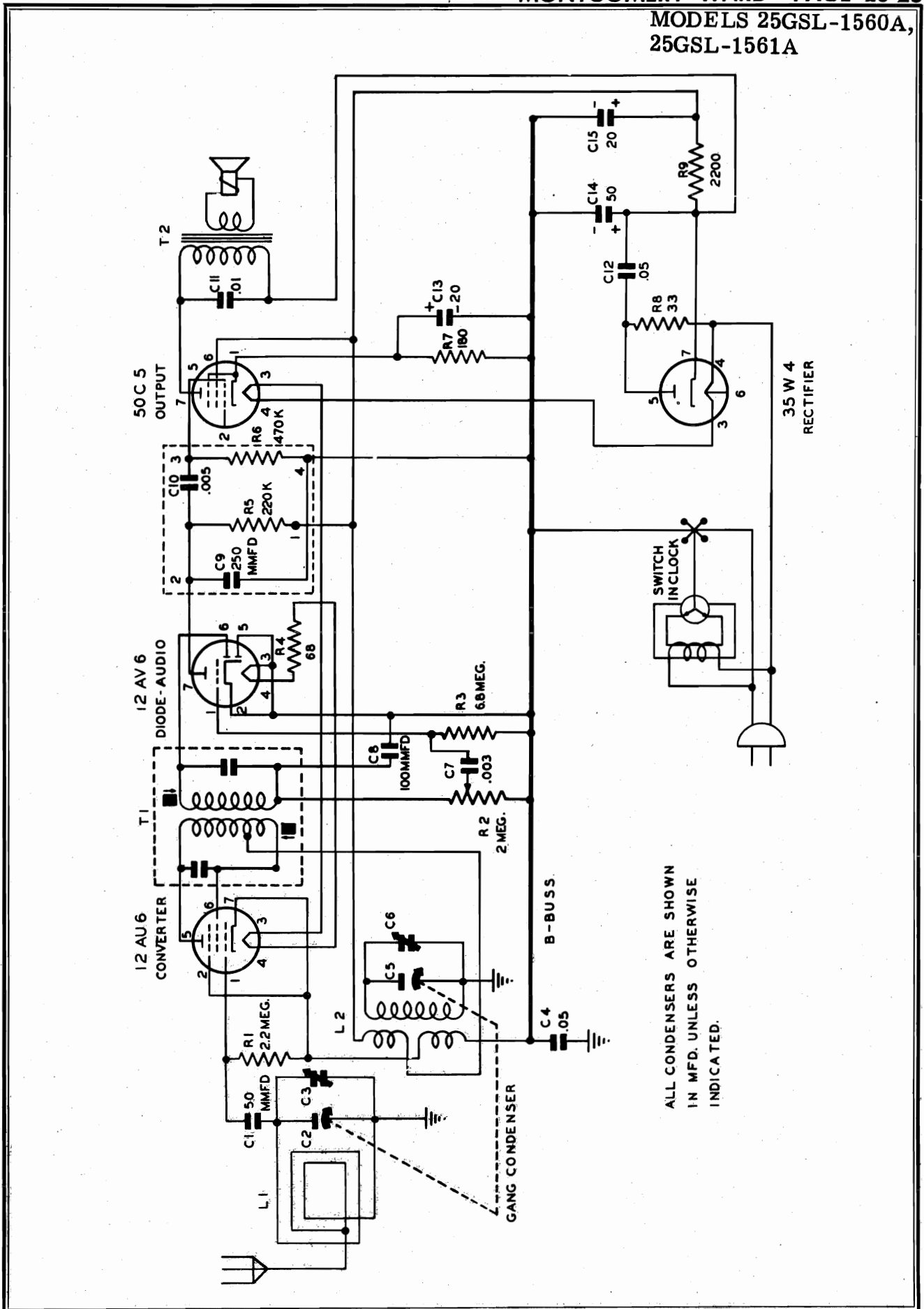

MODELS 25GSL-1560A,
25GSL-1561A

REF. NO.	PART NO.	DESCRIPTION	SELLING PRICE
CONDENSERS			
C1	N-6385	50 MMFD. 500 Volts 10%	\$.16
C2, C5 C3, C6	N-8675	Gang Tuning Condenser Trimmers on Gang Condenser	1.62
C4	N-1345	Paper .05 MFD. 200 Volts16
C7	N-2063	Paper .003 MFD. 600 Volts14
C8	N-6015	Ceramic 100 MMFD. 500 Volts14
*C9	N-6488	Ceramic 250 MMFD. 500 Volts16
*C10	N-4894	Paper .005 MFD. 600 Volts16
C11	N-1344	Paper .01 MFD. 400 Volts16
C12	N-1346	Paper .05 MFD. 400 Volts18
C13) C14) C15)	N-8677	Electrolytic (20 MFD. 15 Volts) (50 MFD. 150 Volts) (20 MFD. 150 Volts)	1.46
RESISTORS			
R1	N-4277	2.2 Megohm, 1/2 Watt, 20%14
R2	N-8674	2.0 Megohm, Volume Control64
R3	N-4028	6.8 Megohm, 1/2 Watt, 20%14
R4	N-6014	68 Ohm, 2 Watts, 10%18
*R5	N-4026	220K Ohms, 1/2 Watt, 20%14
*R6	N-4027	470K Ohms, 1/2 Watt, 20%14
R7	N-4067	180 Ohms, 1/2 Watt, 10%14
R8	N-4022	33 Ohms, 1/2 Watt, 20%14
R9	N-4896	2,200 Ohms, 1/2 Watt, 10%14
TRANSFORMERS & COILS			
T1	N-7694	Transformer, 1st, I.F. Output Transformer (Part of Speaker & Output Transformer Assembly).	1.32
L1	N-8657	Loop Antenna & Cabinet Assembly	1.24
L2	N-8681	Oscillator Coil76
MISCELLANEOUS ELECTRICAL PARTS			
	N-7824	Speaker 4" PM with Transformer	3.68
	N-7334	Tube Socket, 7 Pin Miniature14
	N-1090	Line Cord and plug58
	N-8663	Clock, Electric.	8.68
	N-8215	Audio Couplate42
* The resistors (R5 and R6) and condensers (C9 and C10) are replaced by the Audio Couplate in some receivers.			
MISCELLANEOUS PARTS			
	#360	Cabinet, Plastic - White	3.32
	#367	Cabinet, Plastic - Yellow	3.32
	N-8665	Knob, Tuning - White30
	N-8711	Knob, Tuning - Yellow30
	N-8712	Knob, Volume - White14
	N-8713	Knob, Volume - Yellow14
	N-8664	Knobs, Clock - Gray14
	N-8662	Escutcheon, Clock	1.56

IMPORTANT: All prices in this literature are subject to change without notice, and are subject to an additional charge to cover any applicable sales tax, use, occupation, or other tax affecting our purchase or sale of merchandise.

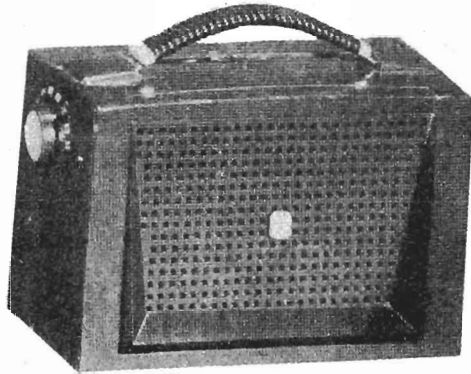

ELECTRICAL SPECIFICATIONS

POWER SUPPLY: VOLTAGE - 110-120 Volt Direct Current or 110-120 Volt 50-60 Cycle Alternating Current. 12 Watts

OR

BATTERIES - One 4-1/2 Volt "A" Battery (Cat. No. 62-26). One 90 Volt "B" Battery (Cat. No. 62-46).

FREQUENCY RANGE: 540 to 1600 KC

INTERMEDIATE FREQ: 455 KC

POWER OUTPUT -
Undistorted - 180 MW
Maximum - 300 MW

LOUD SPEAKER - 4 Inch Round P. M.

VOICE COIL IMPEDANCE - 3.2 Ohms at 400 Cycles.

GENERAL DESCRIPTION

4 Tubes Plus Selenium Rectifier. Operates Either On Electric Current or Self-Contained Batteries. Built-in Iron Core Rod Type Antenna. Permanent Magnet Dynamic Speaker. Automatic Volume Control.

BATTERY INFORMATION

BATTERY TYPE	A - BATT. 4-1/2V	B - BATT. 90 V
MONTGOMERY WARD	62-26	62-46
Eveready	736	490
Burgess	F3	N-60
Ray-O-Vac	P93A	4390
General Dry Battery	38 OR 3F3	132

TUBE COMPLEMENT

- 1R5 - Converter
- 1U4 - I. F. Amplifier
- 1U5 - Diode-Audio Amplifier
- 3V4 - Power Output
- Rectifier - Selenium Type

ALIGNMENT PROCEDURE

For alignment procedure read tabulations from left to right and make the adjustments marked (1) first. (2) next. (3) third.

Before starting alignment:

- (A) Remove the chassis and loop antenna from the cabinet at the same time by removing the battery connectors from the batteries, pulling off knobs and removing the two screws on the chassis tabs which fasten the chassis to the cabinet.
- (B) Use an accurately calibrated test oscillator with some type of output measuring device.

MODEL
25GSL-1072A

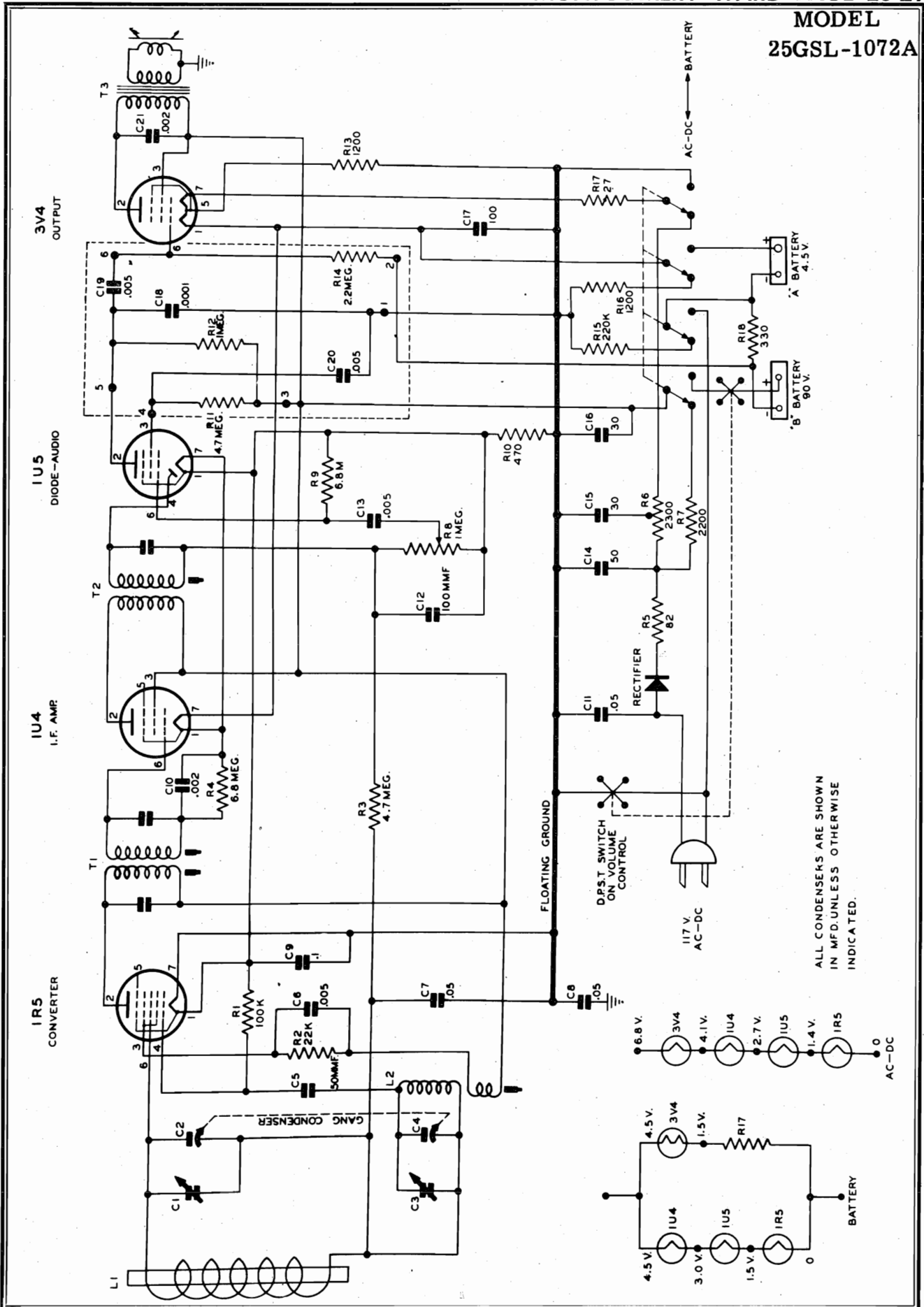

PARTS LIST

REF. NO.	PART NO.	DESCRIPTION	SELLING PRICE
CONDENSERS			
C1,C3 C2,C4	N-8321	Trimmers on Gang Condenser Gang Tuning Condenser	\$ 1.60
C5 C6,C13	N-6375 N-4894	Ceramic 50 MMFD. 500 Volts 20% Paper .005 MFD. 600 Volts16 .16
C7,C8 C9	N-1345 N-1351	Paper .05 MFD. 200 Volts Paper .1 MFD. 200 Volts16 .20
C10,C21 C11	N-6377 N-1346	Paper .002 MFD. 600 Volts Paper .05 MFD. 400 Volts16 .16
C12	N-6015	Ceramic 100 MMFD. 500 Volts 20%16
C14) C15) C16) C17)	N-6841	Electrolytic (50 MFD. 150 Volts) (30 MFD. 150 Volts) (30 MFD. 150 Volts) (100 MFD. 25 Volts)	2.02
C18,C19,C20		Part of N-8330 Pentode Couplate (See Miscellaneous Electrical Parts)	
RESISTORS			
R1 R2	N-2973 N-6012	100K Ohms, 1/2 Watt, 10% 22K Ohms, 1/2 Watt, 10%14 .14
R3 R4,R9 R5	N-4061 N-4028 N-4023	4.7 Megohms, 1/2 Watt, 20% 6.8 Megohms, 1/2 Watt, 20% 82 Ohms, 2.0 Watts, 10%14 .14 .20
R6	N-8333	Candohm 2,300 Ohms, 5.6 Watts, 5% (Center Tapped)68
R7 R8	N-4896 N-8332	2,200 Ohms, 1/2 Watt, 10% 1.0 Megohm, Volume Control & Switch14 1.16
R10 R11,R12,R14	N-4066	470 Ohms, 1/2 Watt, 10% Part of N-8330 Pentode Couplate (See Miscellaneous Electrical Parts)	.14
R13,R16 R15	N-6793 N-4026	1,200 Ohms, 1/2 Watt, 10% 220K Ohms, 1/2 Watt, 20%14 .14
R17 R18	N-6792 N-4420	27 Ohms, 1/2 Watt, 10% 330 Ohms, 1/2 Watt, 10%14 .14
TRANSFORMERS & COILS			
T1 T2 T3	N-7981 N-8326 N-8329	Transformer, 1st. I. F. Transformer, 2nd. I. F. Transformer, Output.	1.20 1.12 1.44
L1 L2	N-8328 N-8327	Coil, Ferrite Loopstick. Coil, Oscillator	1.88 .76
MISCELLANEOUS ELECTRICAL PARTS			
	N-6681 N-8331	Speaker, 4" PM Rectifier, Selenium	2.90 1.48
	N-5951 N-8418	Switch, Power Changeover Line Cord and Plug88 1.12
C18,C19) C20,R11) R12,R14)	N-8330	Pentode Couplate68
MISCELLANEOUS PARTS			
	354-A N-8410	Cabinet Assembly (Less Handle) Handle	5.18 .84
	354-B N-8338 N-8467	Cabinet Back (Includes Hinge and retaining clips) Hinge, Cabinet Back Spring Clip, Cabinet Back Retaining.	1.78 .16 .10
	N-8335 N-8346	Knob, Tuning Knob, Volume28 .28
	N-8649	Grille Cloth and Baffle80

IMPORTANT: All prices in this literature are subject to change without notice and are subject to an additional charge to cover any applicable sales tax, use, occupation, or other tax affecting our purchase or sale of merchandise.



GENERAL DESCRIPTION

RADIO

- Six tubes including tube rectifier.
- Built-In loop antenna.
- Permanent Magnet Dynamic Speaker.
- Variable Tone Control.

PHONO

Motor Speeds of 33, 45 and 78 RPM.

Automatically plays either ten 12", twelve 10" or fourteen 7" records at either 33-1/3, 45 or 78 RPM.

Automatically shuts off after last record has played.

Automatically intermixes ten 10" and 12" records of same speed.

Spindle adapters for 45 RPM record.

VM950 Changer —

ELECTRICAL SPECIFICATIONS

POWER SUPPLY — 110 to 120 volts 60 cycles (Alternating Current)

FREQUENCY RANGE — 540 to 1600 KC

INTERMEDIATE FREQUENCY — 455 KC

POWER OUTPUT — Undistorted .8 Watt
Maximum 1.4 Watts

SENSITIVITY — 18 microvolts average for .05 watts output

SELECTIVITY — 1000 KC, 44 KC at 1000 X signal

LOUD SPEAKER — 8 Inch Round P.M.

VOICE COIL IMPEDANCE — 3.2 Ohms at 400 cycles

TUBE COMPLIMENT

12BA6	R. F. Amplifier
12BA6	I. F. Amplifier
12BE6	Converter
12AV6	Diode — 1st Audio
35C5	Power Output
35W4	Rectifier

520A

ALIGNMENT PROCEDURE

The signal source must be an accurately calibrated signal generator capable of supplying 455 Kc and up to 1620 Kc output near 0.4 volts. signals modulated 30% with a 400-cycle audio signal.

Volume control at maximum for all adjustments. Loop antenna should be connected to receiver and in its proper position when making the adjustments.

SIGNAL GENERATOR				TUNER SETTING	ADJUSTMENT
Frequency	Coupling Capacitor	Connection To Radio	Ground Connection		
455 Kc.	.05 MFD.	Pin 7 of 12BE6 Converter	B Minus Buss Lead	Any Point Near Center Where No Interfering Signal Is Received	Slugs at Top and Bottom of 2nd I. F. (T2) and then both Slugs of 1st I. F. (T1) for Maximum Output.
455 Kc.	---	Lay Generator Lead Near Loop	B Minus Buss Lead	Set At Maximum Capacity	I. F. Trap Slug (L3) for MINIMUM Output.
1620 Kc.	.05 MFD.	Antenna Stator Plates of Tuning Condenser	B Minus Buss Lead	1620 Kc.	Oscillator Trimmer of Gang (C3) for Maximum Output.
1400 Kc.	---	Lay Generator Lead Near Loop	B Minus Buss Lead	1400 Kc.	Antenna Trimmer of Gang (C1) For Maximum Output.

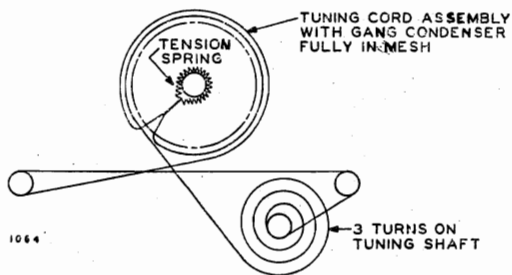

DIAL STRINGING

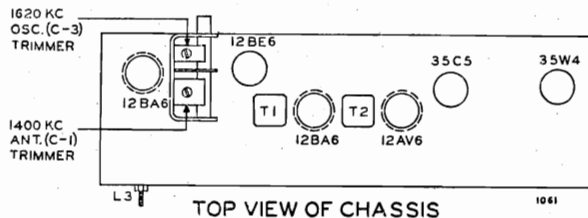

REAR OF CHASSIS

ALL VOLTAGES EXCEPT HEATERS ARE MEASURED FROM SOCKET CONTACTS TO THE COMMON NEGATIVE WITH A 20,000 OHM PER VOLT VOLTMETER. HEATER VOLTAGES ARE MEASURED DIRECTLY ACROSS SOCKET CONTACTS

* AC

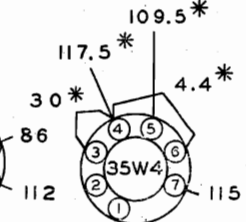
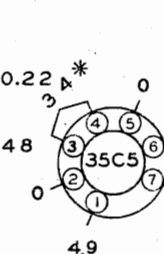
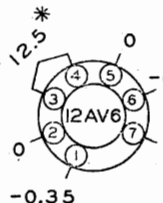
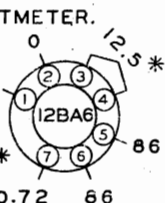
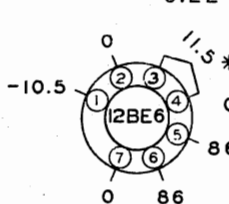
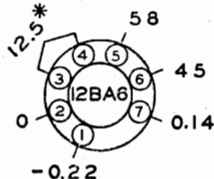

VOLTAGE TABLE
(BOTTOM VIEW OF CHASSIS)

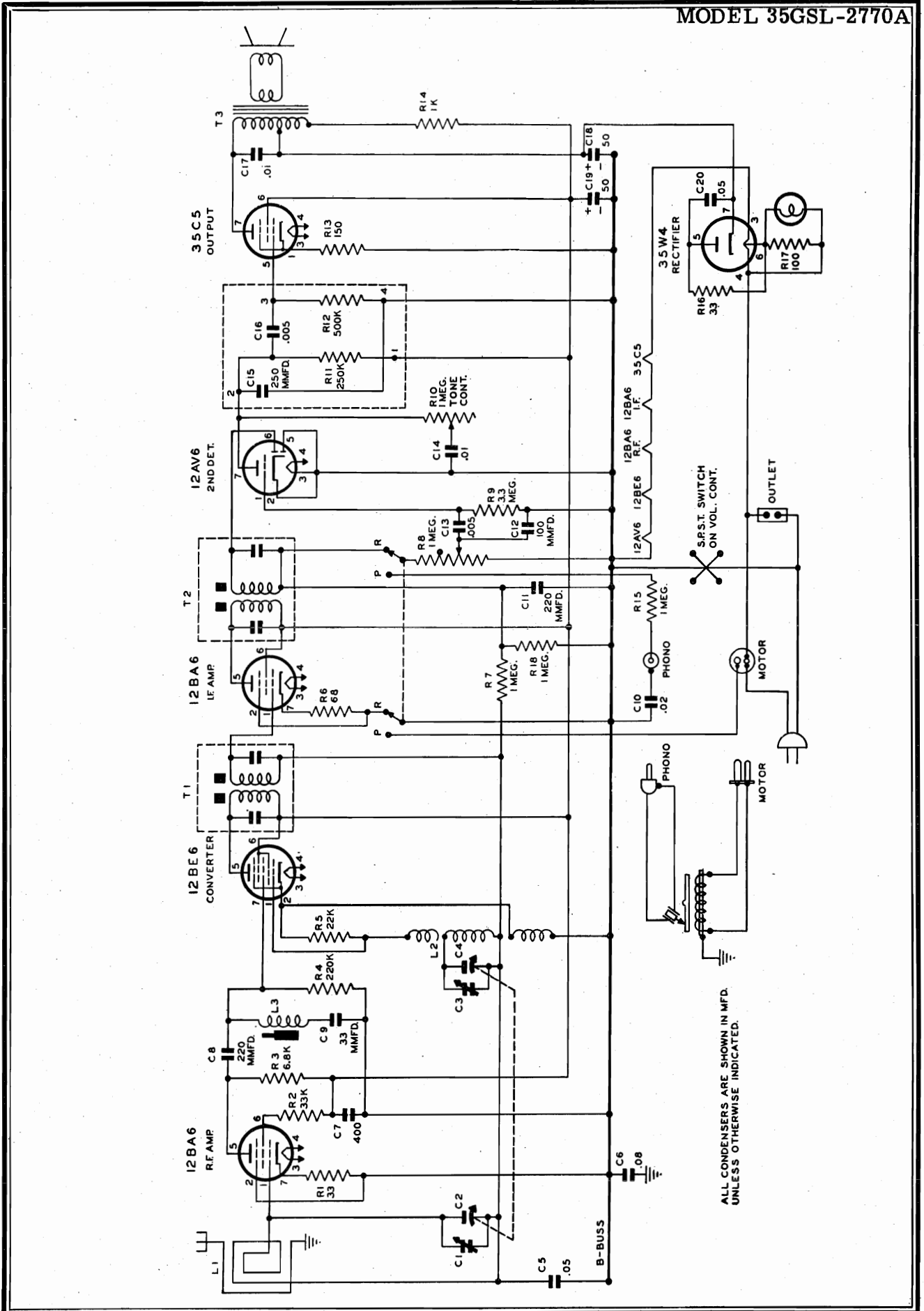

ALL CONDENSERS ARE SHOWN IN MFD.
 UNLESS OTHERWISE INDICATED.

MODEL 35GSL-2770A

REF. NO.	PART NO.	DESCRIPTION	PRICE EACH
CONDENSERS			
C1, C3		Trimmers on Gang Condenser	
C2, C4	N-9658	Assembly, Variable Gang Condenser & Pulley	\$2.38
C5		Paper .05 MFD. 200 Volts	
C6	N-8092	Paper .08 MFD. 200 Volts	.19
C7, C17, C14		Paper .01 MFD. 400 Volts	
C8, C11	N-9655	Ceramic 220 MMFD. 500 Volts 20%	.14
C9	N-9577	Ceramic 33 MMFD. 600 Volts 10%	.14
C10		Paper .02 MFD. 400 Volts	
C12		Ceramic 100 MMFD. 500 Volts 10%	
C13, *C16		Paper .005 MFD. 600 Volts	
*C15		Ceramic 250 MMFD. 500 Volts	
C18}	N-9641	Electrolytic { 50 MFD. 150 Volts	1.80
C19}		50 MFD. 150 Volts	
C20		Paper .05 MFD. 400 Volts	
RESISTORS			
R1		33 Ohms ½ Watt 10%	
R2		33K Ohms ½ Watt 10%	
R3		6800 Ohms ½ Watt 10%	
R4, *R11		220K Ohms ½ Watt 20%	
R5		22K Ohms ½ Watt 20%	
R6		68 Ohms ½ Watt 10%	
R8	N-9639	Volume Control & Switch 1.0 Megohm	.97
R7, R15, R18		1 Megohm ½ Watt 20%	
R9		3.3 Megohms ½ Watt 20%	
R10	N-9642	Variable Tone Control 1.0 Megohm	.65
*R12		470K Ohms ½ Watt 20%	
R13		150 Ohms ½ Watt 10%	
R14		1000 Ohms 1.0 Watt 10%	
R16		33 Ohms ½ Watt 20%	
R17		100 Ohms ½ Watt 20%	
TRANSFORMERS & COILS			
T1, T2	N-9657	1st & 2nd I. F. Transformers	1.28
T3	N-9664	Output Transformer	1.73
L1	N-9652	Loop Antenna Coil	1.40
L2	N-8709	Oscillator Coil	.70
L3	N-9650	I. F. Trap Coil	.70
MISCELLANEOUS PARTS			
	N-8215	Audio Couplate (R11, R12, C15, C16)	.42
	N-9651	8" P.M. Speaker	**7.26
	N-7334	Tube Socket, 7 Pin Miniature W/ Center Shield	.14
	N-7336	Tubes Socket, 7 Pin Miniature W/O Center Shield	.14
	N-1147	Dial Lamp	.16
		Cartridge Shure P76V — 60H24 W/Needles	
		Needle (For 78 RPM Records) 61H29 Sapphire	
		Needle (For 33-45 RPM Records) 61H30 Sapphire	
	N-1090	Line Cord & Plug	.46
	N-7925	Fiber 45 RPM Record Adapter	.14
	N-9648	Dial Scale	.32
	N-9629	Dial Pointer	.24
	N-9732	Knob, Volume, Tuning, Tone & Switch	.14

* Replacement Parts for Couplate N-8215

** Excise Tax Included

NOTE: Use Universal Parts Where No Part Numbers or Prices Are Shown.

IMPORTANT: All prices in this literature are subject to change without notice, and are subject to an additional charge to cover any applicable sales tax, use, occupation, or other tax affecting our purchase or sale of merchandise.

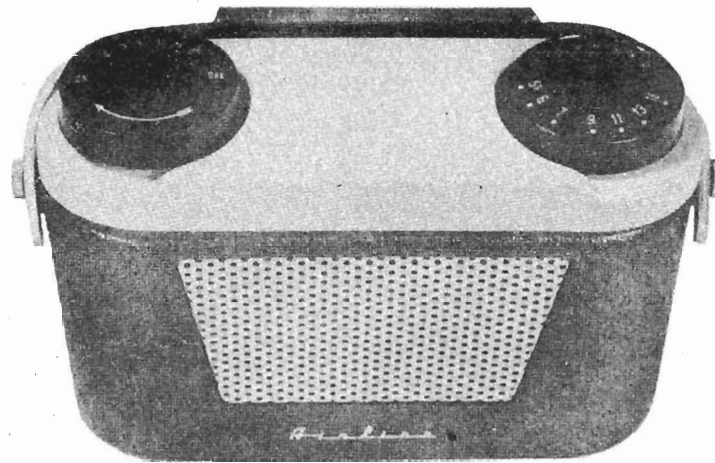

GENERAL

This radio is a personal receiver for broadcast reception, operated from batteries only. It has a tuning Range from 540 to 1640 KC and is equipped with the latest type Ferrite antenna.

TUBE COMPLIMENTS: IR5—Converter
 IT4 or 1L4 I.F. Amplifier
 IU5 Det.—AVC
 1st A.F.
 3V4 Power Amp.

POWER SUPPLY: Batteries as listed on pg.

POWER OUTPUT: 70 Milliwatt undistorted

SPEAKER: 3 1/2" P.M.—V.C.
 impedance 3.2 ohm

SENSITIVITY: 320 Microvolts per meter
 for .05 watt output

BATTERY REQUIREMENTS

The following batteries are required:

QUANTITY	TYPE	MANUFACTURER
2	1 1/2 Volt "A"	Airline #62-23 Eveready size "D", Burgess # 2, Ray-O-Vac size "D" or equivalent.
1	6 7/2 Volt "B"	Airline #62-43 Eveready #467, Burgess type XXD, Ray-O-Vac type #4367 or equivalent.

ALIGNMENT PROCEDURE

Volume Control—Maximum All Adjustments.

Signal Generator which will provide an accurately calibrated signal at the test frequencies as listed.

Output Indicating Meter; Non-Metallic Screwdriver.

Dummy Antenna —.1 mf.

The equipment in column at right is required for aligning:

Frequency Setting	SIGNAL GENERATOR		Ground Connection	Variable Condenser Setting	ADJUST TRIMMERS TO MAXIMUM See Trimmer Illustration
	Coupling Capacitor	Connection to Radio			
455 KC	.1	CONTROL GRID OF IR5	TO CHASSIS	CLOSED	1st AND 2nd I.F. A1 - A2 - A3 - A4
540 KC	.1	CONTROL GRID OF IR5	TO CHASSIS	CLOSED	OSCILLATOR COIL SCREW
1640 KC	.1	CONTROL GRID OF IR5	TO CHASSIS	WIDE OPEN	OSCILLATOR TRIMMER A5
1400 KC	.1	CONTROL GRID OF IR5	TO CHASSIS	TO 1400 KC SIGNAL	ANTENNA TRIMMER A6

MODEL 15GHM-1067A

BATTERY INSTALLATION

"A" Batteries:

Set radio on a table or solid object. Unscrew the thumb screws which hold the handle in place. Lift out Radio chassis carefully. Remove "A" batteries from the battery container and replace. Replace radio chassis with top cover carefully back in the cabinet. Replace thumb screws through handle slots.

"B" Batteries:

Follow same procedure as above except detach "B" battery terminal clip and snap on fresh battery. Re-assemble as instructed in previous paragraph.

SCHMATIC DIAGRAM FOR MODEL 15-GHM-1067A

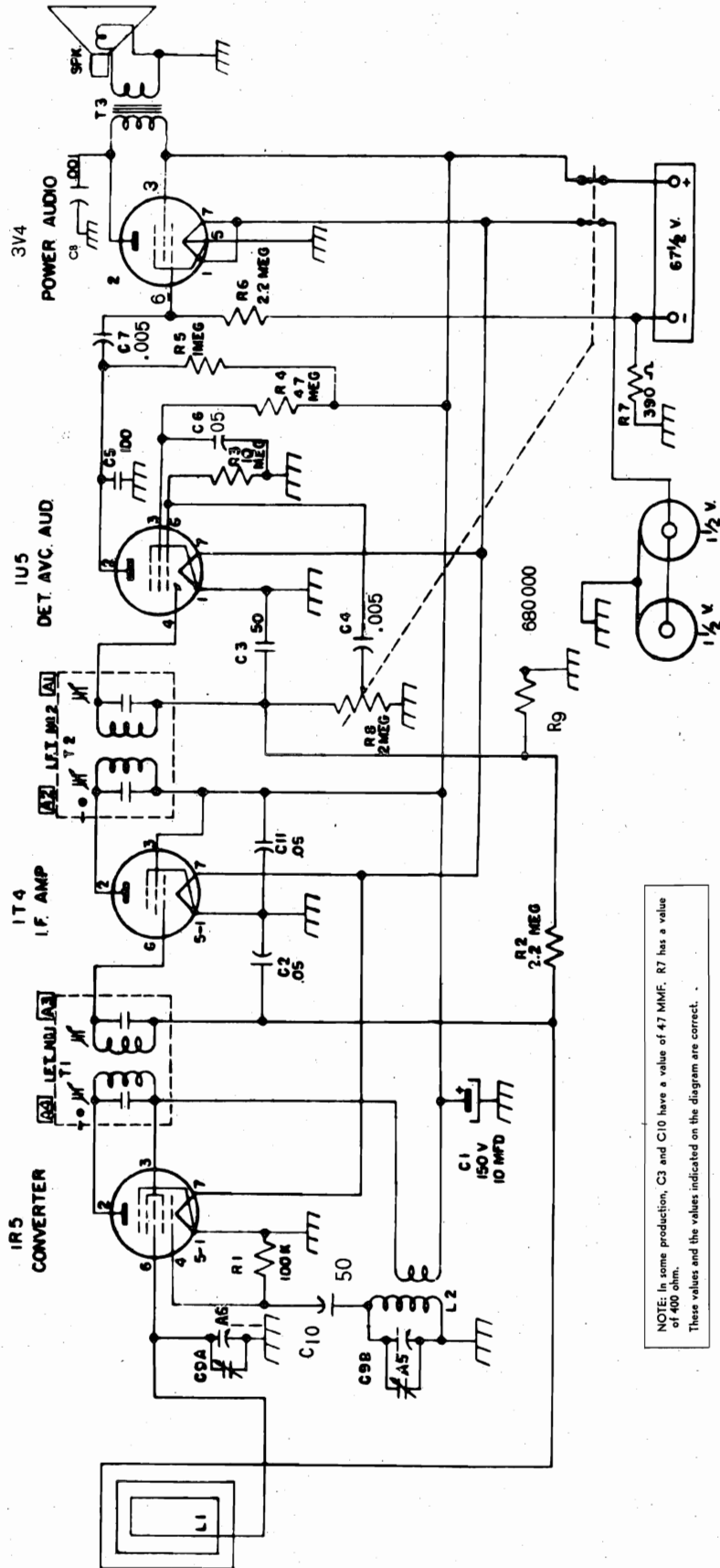

NOTE: In some production, C3 and C10 have a value of 47 MMF. R7 has a value of 400 ohm. These values and the values indicated on the diagram are correct.

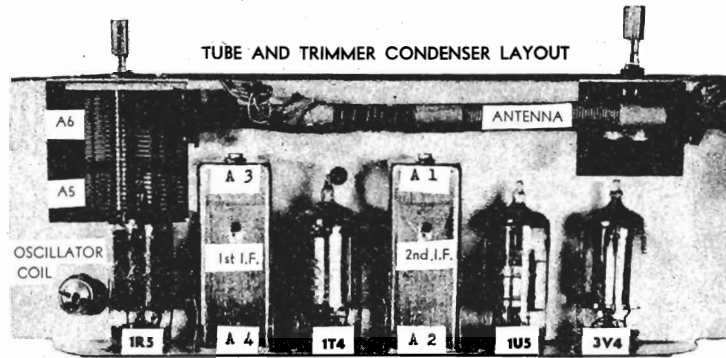

HOW TO ORDER REPAIR PARTS

Repair Parts may be ordered from your nearest Wards Retail Store, Catalog Order Office, or Mail Order House. To have your order filled promptly and correctly, please furnish the following information:

2. Part Number and Name of Part (see Repair Parts List).
You pay charges from shipping point. Shipping charges are based on size and total weight of order. Use any one of the following shipping methods:

1. Model Number which appears on nameplate.*

PARTS LIST

REF. NO.	PART NO.	DESCRIPTION	PRICE
<u>CONDENSERS</u>			
C1	1067-99	10 MFD—100 Volt	.64
C6-C2-C11	1067-100	.05—150 Volt	.26
C3-C10	1067-101	50 MMF—150 Volt	.26
C5	1067-103	100 MMF—150 Volt	.26
C7-C4	1067-105	.005—150 Volt	.26
C8	1067-106	.001—150 Volt	.26
C9-A	1067-107	Variable Condenser	1.60
C9-B			
<u>RESISTORS</u>			
R1	1067-108	100K—1/4 Watt	.20
R2-R6	1067-109	2.2 Meg.—1/4 Watt	.20
R3	1067-110	10 Meg.—1/4 Watt	.20
R4	1067-111	4.7 Meg.—1/4 Watt	.20
R5	1067-112	1 Meg.—1/4 Watt	.20
R7	1067-113	390 Ohms—1/4 Watt	.20
R8	1067-114	Volume Control and Switch 2 Meg.	1.00
R9	1067-114-A	680 K—1/4 Watt	.20
<u>MISCELLANEOUS</u>			
L1	1067-115	Antenna Assembly	1.24
L2	1067-116	Oscillator Coil Assembly	.60
SPR	1067-117	Speaker 3 1/4" P.M. with Output Transformer T3	3.80
T1 T2	1067-118	I.F. Transformer	1.40
	1067-119	Cabinet	6.50
	1067-120	Handle	1.00
	1067-121	"A" Battery Container	.76
	1067-123	"B" Battery Clips & Terminal Strip	.30
	1067-124	Dial "Tuning"	.76
	1067-125	Dial "Volume"	.76
	1067-126	Handle Thumb Screw	.26
	1067-127	Socket, Tube	.10

IMPORTANT—All prices in this literature are subject to change without notice and are subject to an additional charge to cover any applicable sales tax, use, occupation, or other tax affecting our purchase or sale of merchandise.

**Model 25GSE-1555A,
25GSE-1556A**

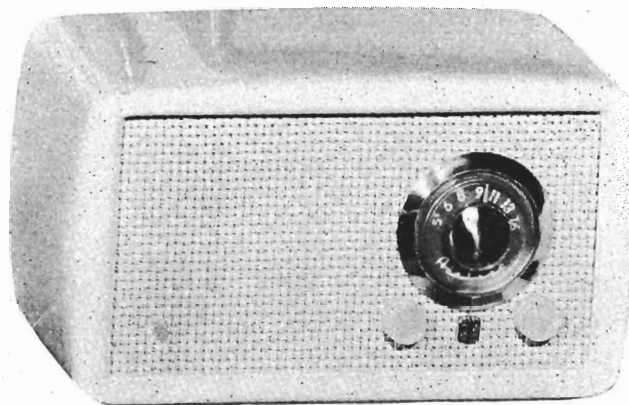

ALIGNMENT PROCEDURE

For alignment procedure read tabulations from left to right, and make the adjustment marked (1) first, (2) next, (3) third.

Before starting alignment:

- (A) Check tuning dial adjustment by tuning gang condenser until plates are completely in mesh, at which point the dial needle must be exactly even with the last line at the low frequency end of the dial calibration. If dial needle does not point exactly to last line move to correct position.
- (B) Use an accurately calibrated test oscillator with some type of output measuring device.
- (C) When the chassis is removed from the cabinet the loop must be mounted on the loop mounting brackets, and the two wires connected to the loop.
- (D) When aligning the 1660 KC OSCILLATOR TRIMMER or the 1400 KC ANTENNA TRIMMER, couple test oscillator to receiver loop by: (1) make loop consisting of five to ten turns of NO. 20 or NO. 30 size wire, wound on a 2" to 3" form; (2) connect this loop across output of test oscillator; (3) place test oscillator loop near radio loop. BE SURE THAT NEITHER LOOP MOVES WHILE ALIGNING.

The 1400 KC ANTENNA TRIMMER should only be adjusted after all other adjustments are made.

ELECTRICAL SPECIFICATIONS

POWER SUPPLY.....	VOLTAGE: 110-120 Volt Direct Current or 110-120 Volt 50-60 cycle Alternating Current. 35 Watts.
TUNING RANGE.....	540 to 1660 KC
INTERMEDIATE FREQ.....	455 K.C.
I.F. STAGES.....	One
LOUD SPEAKER.....	5" P.M.
VOICE COIL IMPEDANCE.....	3.2 OHM
POWER OUTPUT.....	Undistorted .09 Watts Maximum 1.5 Watts

TUBE COMPLEMENT

1	12BE6	MODULATOR:OSCILLATOR
1	12BA6	I.F. AMPLIFIER
1	12AV6	DETECTOR, AVC, 1ST AUDIO
1	50C5	POWER OUTPUT
1	35W4	RECTIFIER

Model 25GSE-1555A,
25GSE-1556A

Steps	Set receiver dial to:	TEST OSCILLATOR			Refer to parts layout diagram for location of trimmers mentioned below:
		Adjust test oscillator frequency to:	Use dummy antenna in series with output of test oscillator consisting of:	Attach output of test oscillator to:	
1	Any point where no interfering signal is received.	455 K. C.	.02 MFD. condenser	High side to rear stator plates of tuning condenser. Low side to common negative.	Adjust each of the second I.F. transformer trimmers for maximum output—then adjust each of the first I.F. trimmers for maximum output.
2	Exactly 1660 K. C.	Exactly 1660 K. C.	See paragraph (D) above.	See paragraph (D) above.	Adjust 1660 K. C. oscillator trimmer for maximum output.
3	Approx. 1400 K. C.	Approx. 1400 K. C.	See paragraph (D) above.	See paragraph (D) above.	Adjust 1400 K. C. antenna trimmer for maximum output.

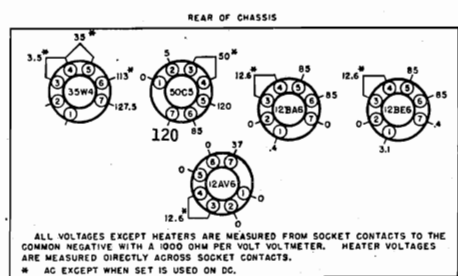
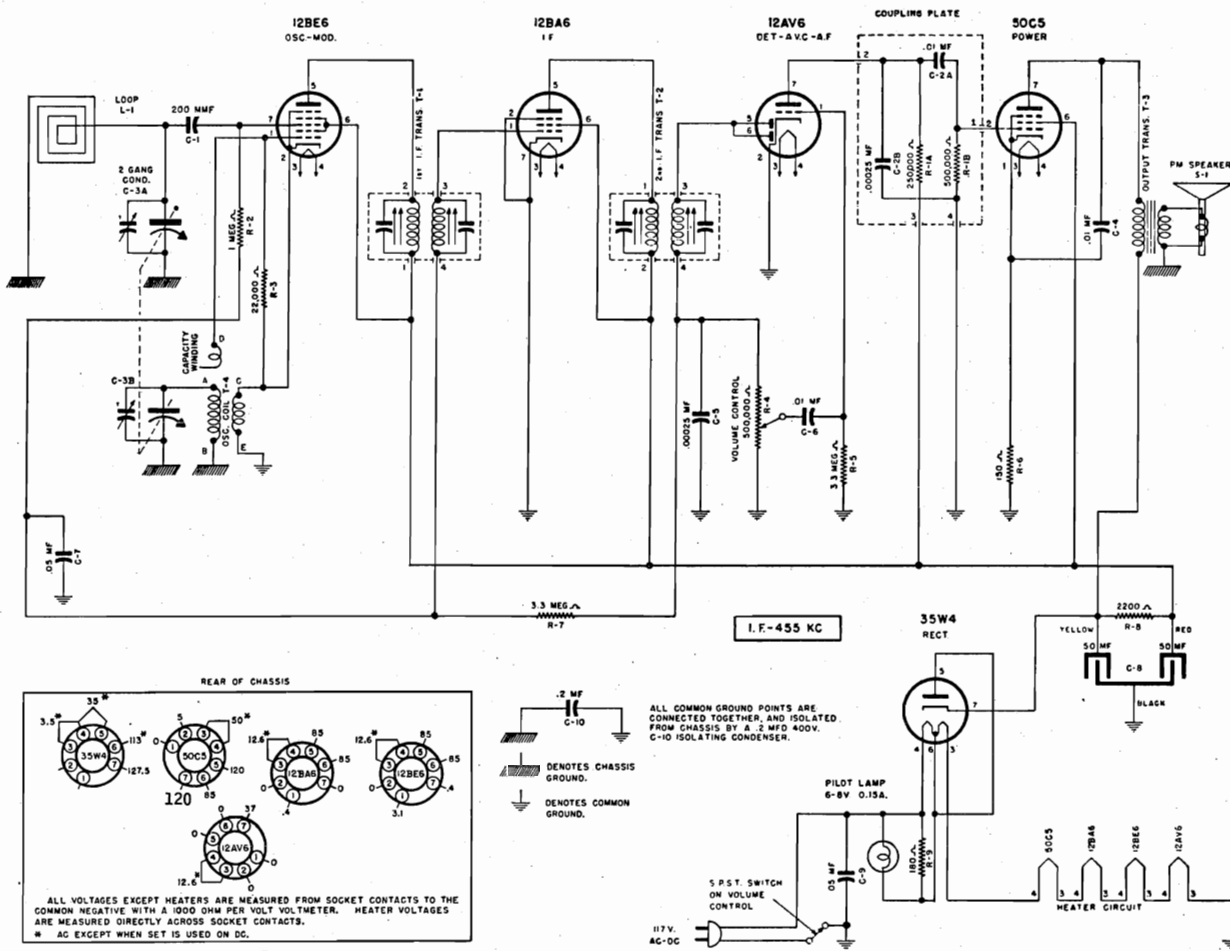

ALL VOLTAGES EXCEPT HEATERS ARE MEASURED FROM SOCKET CONTACTS TO THE COMMON NEGATIVE WITH A 1000 OHM PER VOLT VOLTMETER. HEATER VOLTAGES ARE MEASURED DIRECTLY ACROSS SOCKET CONTACTS.
* AC EXCEPT WHEN SET IS USED ON DC.

VOLTAGE TABLE
(BOTTOM VIEW OF CHASSIS)

PART NO. 25GSE1935

Model 25GSE-1555A,
25GSE-1556A

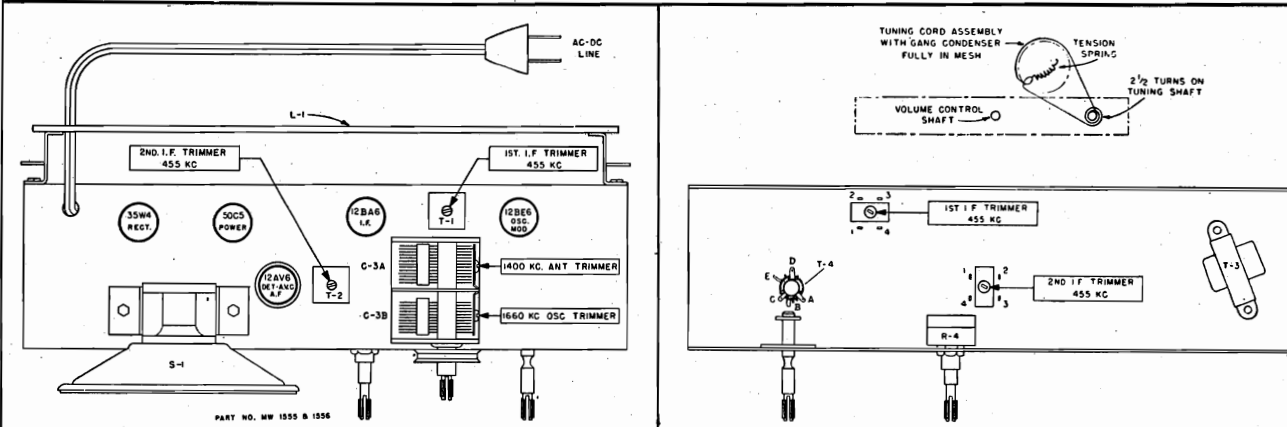

HOW TO ORDER PARTS—Should it be necessary to write us or to order any repair parts, it is important that the complete model number which appears on the label attached to the back of the radio chassis be specified. Repair parts should be ordered from your nearest Wards Retail Store, Catalog Order Office or Mail Order House.

PARTS LIST

Ref. No.	Part No.	DESCRIPTION	Selling Price
CAPACITORS			
C-1	MW23E18	Fixed Ceramic, 200 MMF 500 V.....	\$0.18
C-2A } C-2B }	Part of MW23E2041-2 Couplate (See Misc. Parts)		
C-3A } C-3B }	MW24E58	Capacitor, 2 gang Condenser.....	2.70
C-4	MW23E411	Tubular, .01 MFD 400 V.....	.20
C-5	MW23E2027	Fixed Ceramic, .00025 MF 500 V....	.30
C-6	MW23E211	Tubular, .01 MFD 200 V.....	.20
C-7	MW23E216	Tubular, .05 MFD 200 V.....	.22
C-8	MW25E24	Electrolytic, 50-50 MFD 150 V.....	2.10
C-9	MW23E416	Tubular, .05 MFD 400 V.....	.24
C-10	MW23E2021	Tubular, .2 MFD 400 V.....	.80
RESISTORS			
R-1A } R-1B }	Part of MW23E2041-2 Couplate (See Misc. Parts)		
R-2	MW27E105	Carbon, 1 Megohm 1/3 W.....	.06
R-3	MW27E223	Carbon, 22,000 Ohm 1/3 W.....	.06
R-4	MW28E82	Control, Volume, 500,000 Ohm.....	1.06
R-5 } R-7 }	MW27E335	Carbon, 3.3 Megohm 1/3 W.....	.06
R-6	MW27E151	Carbon, 150 Ohm 1/3 W.....	.06
R-8	MW27E222-5	Carbon, 2200 Ohm 2 W.....	.22
R-9	MW27E181-2	Carbon, 180 Ohm 1/2 W.....	.06
COILS AND TRANSFORMERS			
T-1 } T-2 }	MW20E732	1st & 2nd I.F. Transformer.....	1.56
T-3	MW22E49-2	Transformer, Output	1.50
T-4	MW20E733	Coil, Oscillator	1.34
L-1	MW7E308	Cabinet Back & Loop.....	1.22

Ref. No.	Part No.	DESCRIPTION	Selling Price
MISCELLANEOUS			
	MW1E50	Speaker, 5" P.M.....	5.42
	MW23E2041-2	Ceramic Coupling Plate.....	.62
	MW41E14	Line Cord and Plug Assembly.....	.54
	MW17E1-31	Tube Socket, Miniature for 35W4, 50B5 or 12AT6.....	.16
	MW17E1-22	Tube Socket, Miniature for 12BA6 or 12BE614
	MW7E306-2	Cabinet, Green	8.92
	MW7E306-3	Cabinet, White	8.92
	MW10E42	Trimount Stud02
	MW20E736	Baffle Assembly for Green Cabinet	3.92
	MW20E736-2	Baffle Assembly for White Cabinet	4.14
	MW35E32	Dial Pointer50
	MW37E76	Knob for Green Cabinet.....	.24
	MW37E76-2	Knob for White Cabinet.....	.24
	MW48E25	Dial Bezel for Green Cabinet.....	1.76
	MW48E25-2	Dial Bezel for White Cabinet.....	1.76
	MW20E348-9	Dial Drive Shaft & Bracket Assembly34
	MW20E253-39	Dial Drive Cord.....	.12
	MW65E2	Dial Cord Tension Spring.....	.06

PRICES SUBJECT TO CHANGE WITHOUT NOTICE.

MODELS 52M1U, 52M2U,
52M3U, Ch. HS-300

GENERAL INFORMATION

TYPE - Three-power (AC/DC, Battery) portable radio receiver. Four miniature type tubes and a selenium rectifier are used in a superheterodyne circuit.

RECEIVER MODELS	Model	Color
	52M1U	Green
	52M2U	Maroon
	52M3U	Gray

TUNING RANGE - 535 to 1620 Kc **IF** - 455 Kc

POWER SUPPLY -

Operates from 117V AC/DC (15 watts)
or from the following batteries:

2-1-1/2 volt flashlight cells

- Use: Eveready 950
- or Burgess 2
- or Ray-O-Vac 2LP
- or any equivalent size "D" flashlight cell.

1-67-1/2 volt "B" battery

- Use: Eveready 467
- or Burgess XX45
- or Ray-O-Vac 4367
- or equivalent.

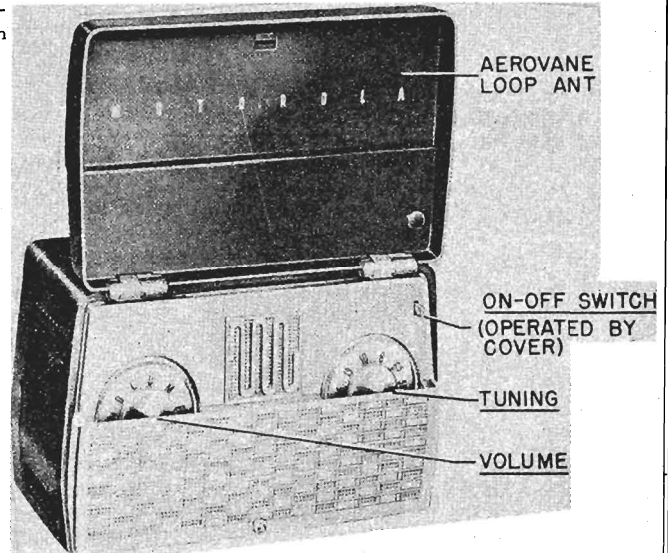

TUBE COMPLEMENT - Type	Function
1R5	Converter
1U4	IF Amplifier
1U5	Det, AVC & 1st AF Amp
3S4	Power Amplifier
Rectifier	Selenium type -for AC/DC operation

OPERATING INSTRUCTIONS

TO OPEN FRONT COVER. The front cover is opened by pushing up on the cover release button, located in the center of the front cover. The receiver is automatically turned on when the front cover is opened and raised to a vertical position.

TO OPEN BACK COVER. The back cover is opened by grasping it at the top and gently pulling cover open. When closing the cover, be careful not to pinch the power line cord or other leads between the cover and the cabinet.

HOUSE CURRENT OPERATION. The power cord is located inside the cabinet and can be reached by opening the back cover. Pass the line cord through the slot on the side of the receiver before closing the cover. Plug the power cord into any 117 volt AC or DC power outlet. Reverse the line cord plug in power outlet if the receiver does not operate from DC power. When operating from AC power, reception may sometimes be improved by reversing the power plug in power outlet. It is not necessary that batteries be installed if the receiver is to be operated only from house power lines.

BATTERY OPERATION. Open the back cover and install batteries by following the instructions found on label located on back cover or as shown in Figure 2. Plug the power line cord into the receptacle on the receiver chassis, as shown on label, or the receiver will not play from batteries. If the receiver is to be operated for a long period of time from AC or DC house power lines, or is to be placed in storage, remove the batteries and store them in a cool place.

IMPORTANT: Never leave low or run-down batteries in your receiver because they will leak or swell and damage your receiver.

TUNING CONTROL. Stations are tuned in with the right-hand knob. Tune carefully until you are exactly on a station; tuning to either side of it will result in poor tone quality and excessive noise. Do not regulate volume by detuning the station; always tune exactly on the station, then adjust volume control to desired loudness.

VOLUME CONTROL. The left-hand knob controls volume. Rotation to the right will increase volume; rotation to the left will decrease it.

TO TURN OFF. Closing the front cover will automatically turn off the receiver.

ANTENNA. A super-sensitive "Aerovane" loop antenna is built into the front cover of this receiver. Because of the slightly directional characteristics of the loop antenna, reception from some stations may be improved by rotating the receiver. In extremely noisy locations, rotate the receiver until minimum noise and maximum signal pick-up is obtained.

BATTERY REPLACEMENT. If low volume or fuzzy tone is noticed when operating from batteries, replace the flashlight cells. Normally, the 67-1/2 volt "B" battery will last for 3 or 4 changes of the flashlight cells.

NOTE: The condition of the batteries will not affect operation of receiver from 117 volts AC or DC. Complete battery replacement instructions will be found inside the receiver back cover.

68P620328

MODELS 52M1U, 52M2U,
52M3U, Ch. HS-300

SERVICE NOTES

The chassis of this receiver is isolated from the AC power line circuit by a capacitor-choke assembly to eliminate the shock hazard when handling the receiver. However, as an additional precaution when aligning or servicing the receiver from AC, an isolation transformer should be inserted between the power line and the chassis.

The tubes are exposed when the rear cover is opened. It is not necessary to remove the chassis to replace tubes.

TO REMOVE THE CHASSIS FROM THE CABINET:

1. Open the rear cover and remove the batteries.
2. Remove the two hex head screws that mount the chassis to the cabinet.
3. Slide the chassis from the cabinet.
4. Disconnect the two loop antenna leads from the hinges.

ALIGNMENT

NOTE: The receiver may be operated either from batteries or from the commercial power lines during alignment. If AC power is used, it is recommended that an isolation transformer be placed between the power line and the receiver. If an isolation transformer is not available, connect the low side of the signal generator to B- through a .1 mf capacitor.

1. Connect a low range output meter across the speaker voice coil.
2. Connect the low side of the signal generator to B-.
3. Set the signal generator for 400 cycle, 30% modulation.
4. Turn the receiver volume control to maximum.
5. Use a small fibre screwdriver for aligning the IF and diode transformers.
6. Adjust the signal generator output to produce .40 volts (.05 watts) across the voice coil. As stages are aligned, to avoid overloading the receiver, reduce the generator output to maintain the .40 volt level.
7. See Figure 1 for adjusting locations and the following chart for procedure.

ALIGNMENT CHART

STEP	DUMMY ANTENNA	GENERATOR CONNECTION	GENERATOR FREQUENCY	GANG SETTING	ADJUST	REMARKS
IF ALIGNMENT						
1.	.1 mf	Grid of conv (pin 6, 1R5)	455 Kc	Fully open	1, 2 & 3 (IF cores)	Adjust for maximum.
RF ALIGNMENT						
2.	.1 mf	Grid of conv (pin 6, 1R5)	1620 Kc	Fully open	4 (Osc)	Adjust for maximum.
3.	-	-	-	-	-	Install chassis in cabinet, leaving output meter connected to speaker.
4.	-	Radiation loop*	1400 Kc	Tune for max	5 (Ant)	Adjust for maximum. Trimmer is reached through hole under plug button on side of cabinet.

*Connect generator output across 5" diameter, 5 turn loop and couple inductively to receiver loop. Keep loops at least 12" apart.

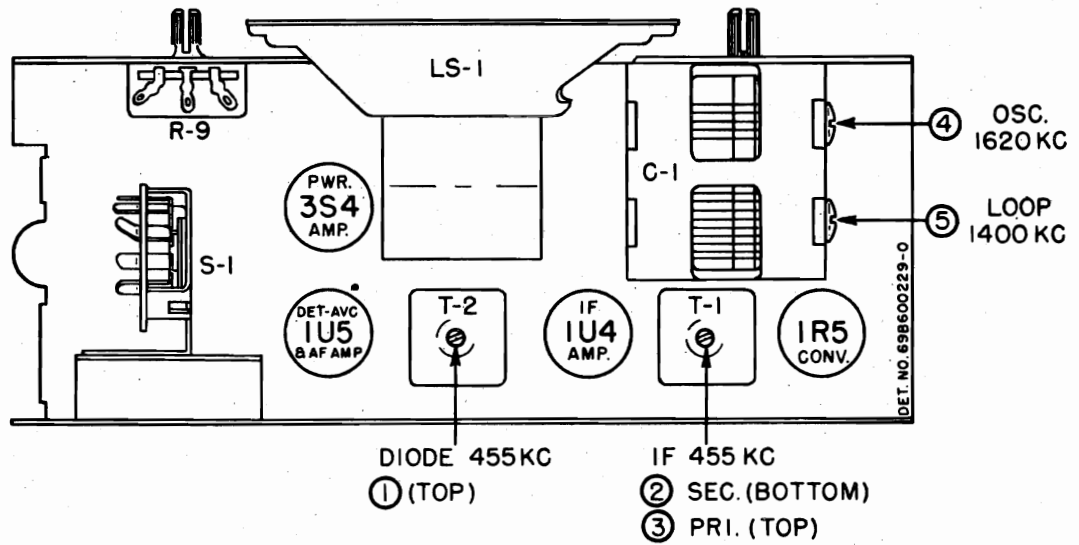

FIGURE 1. TUBE AND TRIMMER LOCATIONS

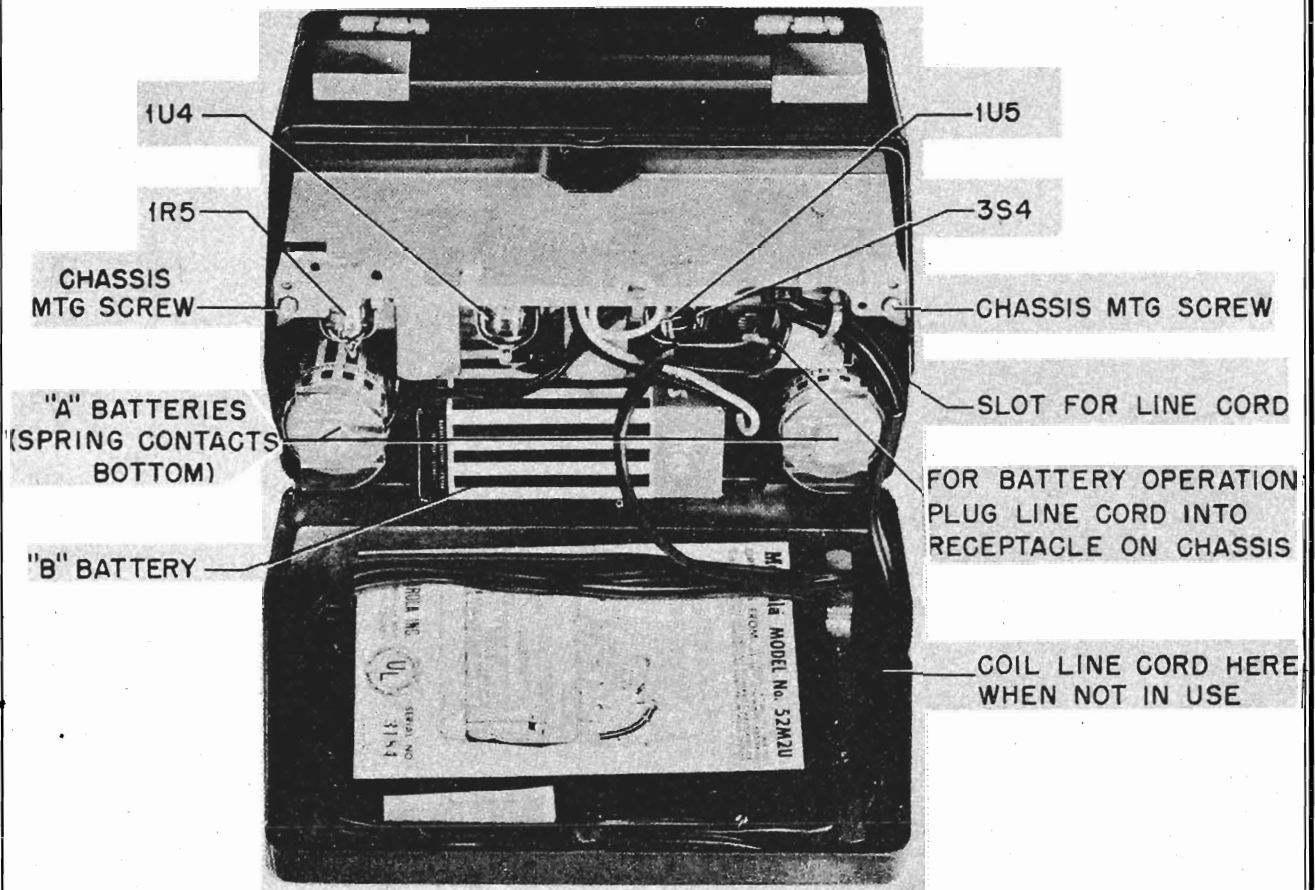

FIGURE 2. REAR VIEW OF RECEIVER

MODELS 52M1U, 52M2U,
52M3U, Ch. HS-300

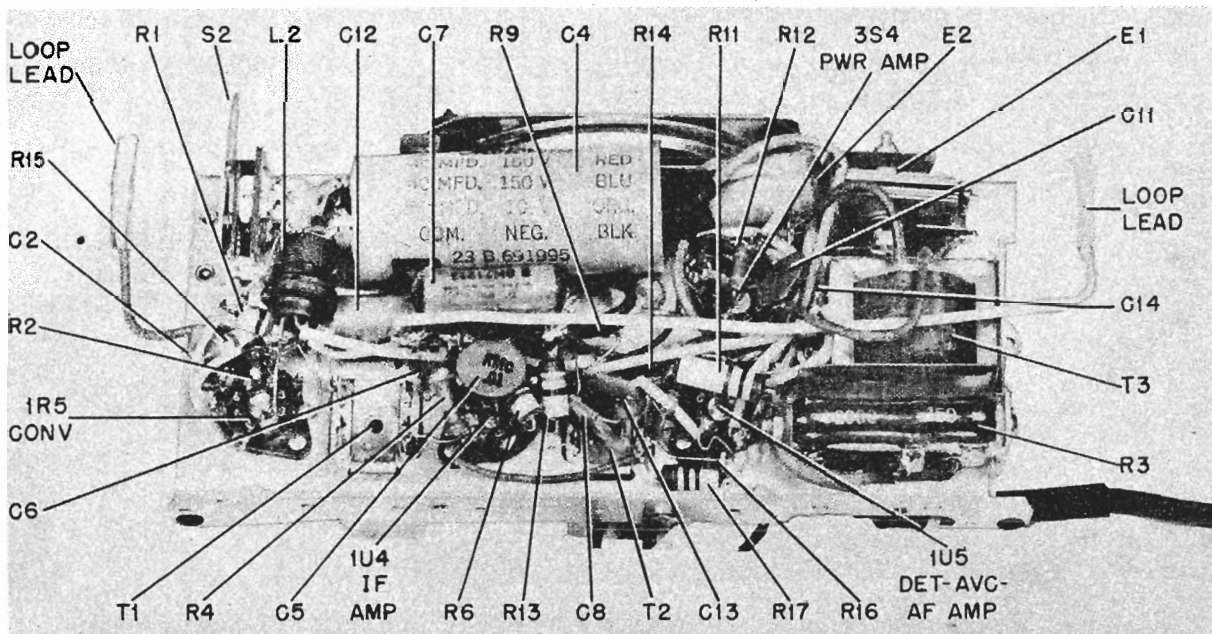
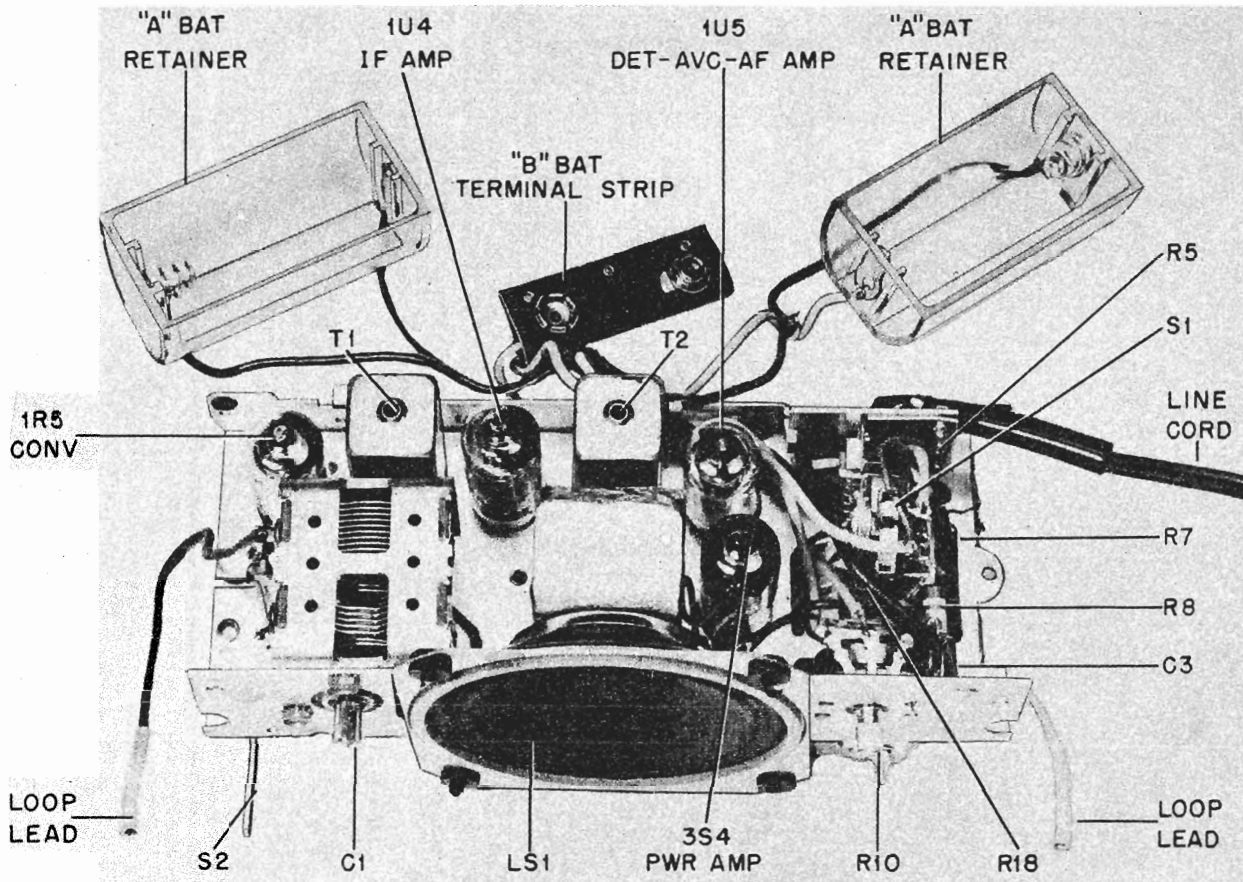
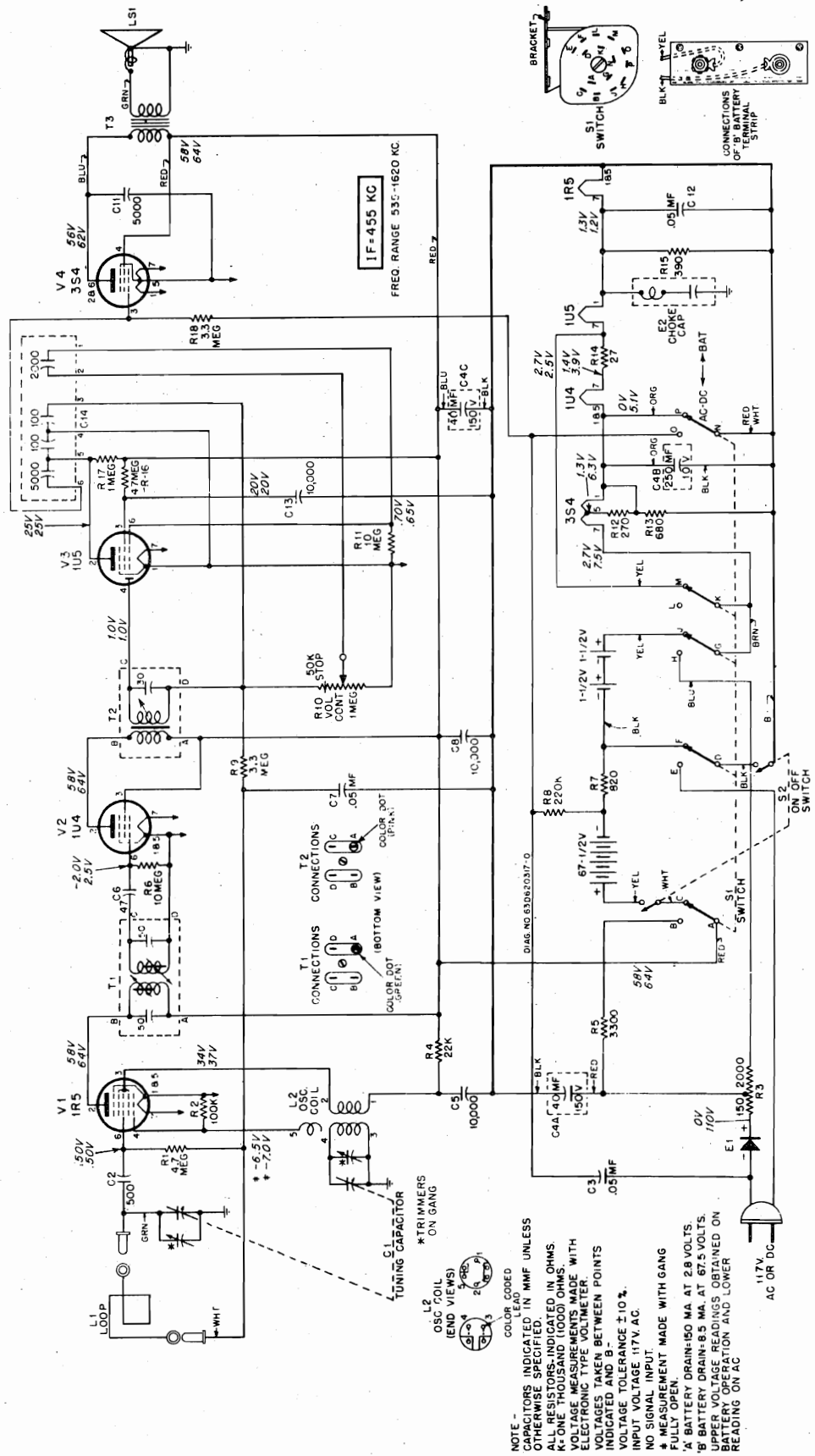

FIGURE 3. PARTS LOCATIONS



NOTE -
 CAPACITORS INDICATED IN MMF UNLESS OTHERWISE SPECIFIED.
 ALL RESISTORS INDICATED IN OHMS UNLESS OTHERWISE SPECIFIED.
 VOLTAGE MEASUREMENTS MADE WITH ELECTRONIC TYPE VOLTMETER.
 VOLTAGES TAKEN BETWEEN POINTS INDICATED AND B -
 VOLTAGE TOLERANCE ±10%.
 INPUT VOLTAGE 117V. AC.
 NO SIGNAL INPUT.
 * MEASUREMENT MADE WITH GANG FULLY OPEN.
 'A' BATTERY DRAIN-150 MA AT 28 VOLTS.
 'B' BATTERY DRAIN-8.5 MA AT 67.5 VOLTS.
 UPPER VOLTAGE READINGS OBTAINED ON READING OPERATION AND LOWER READINGS ON AC

FIGURE 4. SCHEMATIC DIAGRAM OF CHASSIS USING MULTIPLE CERAMIC CAPACITOR PLATE

MODELS 52M1U, 52M2U
52M3U, Ch. HS-300

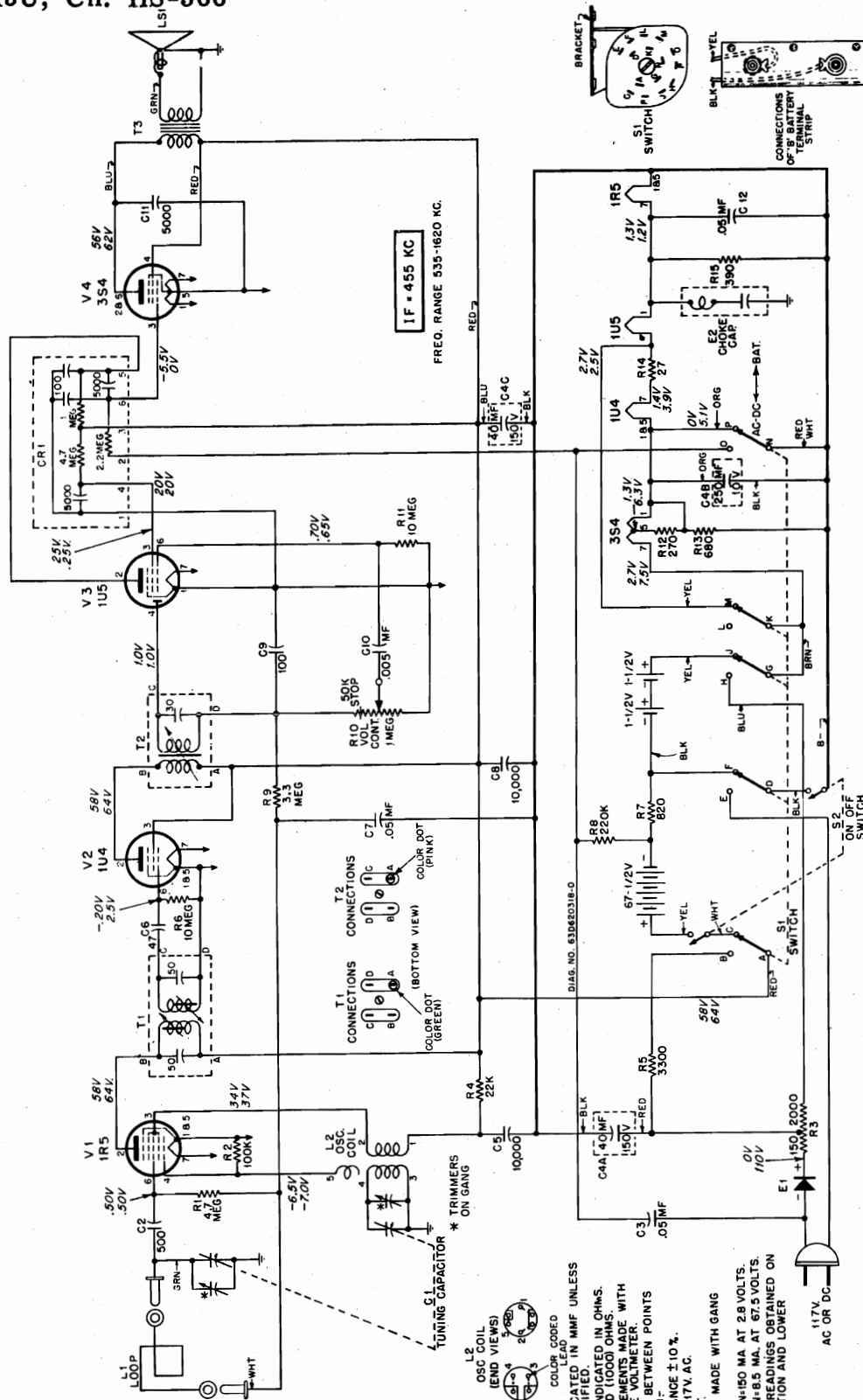

NOTE:-
CAPACITORS INDICATED IN MMF UNLESS OTHERWISE SPECIFIED.
ALL RESISTORS INDICATED IN OHMS.
K= ONE THOUSAND (1000) OHMS.
VOLTAGE MEASUREMENTS MADE WITH ELECTRONIC TYPE VOLTMETER.
VOLTAGES TAKEN BETWEEN POINTS UNLESS OTHERWISE SPECIFIED.
VOLTAGE TOLERANCE ±10%.
INPUT VOLTAGE 117V AC.
NO SIGNAL INPUT.
MEASUREMENT MADE WITH GANG FULLY OPEN.
'A' BATTERY DRAIN-150 MA AT 2.8 VOLTS.
'B' BATTERY DRAIN-8.5 MA AT 67.5 VOLTS.
UPPER VOLTAGE READINGS OBTAINED ON BATTERY OPERATION AND LOWER READING ON AC.

FIGURE 5. SCHEMATIC DIAGRAM OF CHASSIS USING MULTIPLE CERAMIC CAPACITOR-RESISTOR PLATE

PARTS LIST

NOTE: When ordering parts, specify model and chassis numbers of set in addition to part number and description of part.

Ref. No.	Part Number	Description	List Price	Ref. No.	Part Number	Description	List Price
CHASSIS PARTS - ELECTRICAL				Speaker			
Capacitors				LS-1	50K600141		
C-1	19K692007	Variable, 2-gang.....	2.50		or 50K600142		
C-2	21K481377	Ceramic: 500 mmf 500V.....	.20		or 50B610112	Speaker: 3-1/2" PM; 3.2 ohm VC.....	3.75* exch 2.80
C-3	8K471635	Paper: .05 mf 400V.....	.20	Resistors			
C-4	23B691995	Electrolytic: 40-40 mf 150V/250 mf 10V.....	1.75	Note: All resistors are insulated, carbon type unless otherwise specified.			
C-5	21K482726	Ceramic, disc type: 10,000 mmf 450V.....	.30	R-1	6R2122	4.7 meg 20% 1/2W.....doz	1.20
C-6	21K77373	Ceramic: 47 mmf 500V.....	.20	R-2	6R6031	100,000 10% 1/2W.....doz	1.20
C-7	8K71213	Paper: .05 mf 100V.....	.20	R-3	17K692009	Wire wound: 2150 5% 10W; tapped.....	1.05
C-8	21K482726	Ceramic, disc type: 10,000 mmf 450V.....	.30	R-4	6R6397	22,000 10% 1/2W.....doz	1.20
C-9	21B77286	Ceramic: 100 mmf 100V.....	.20	R-5	6R5581	3300 10% 1/2W.....doz	1.20
C-10	8K24966	Paper: .005 mf 100V.....	.20	R-6	6R2109	10 meg 20% 1/2W.....doz	1.20
C-11	21R115312	Ceramic, disc type: 5000 mmf 450V.....	.25	R-7	6R6269	820 10% 1/2W.....doz	1.20
C-12	8K71213	Paper: .05 mf 100V.....	.20	R-8	6R6015	220,000 20% 1/2W.....doz	1.20
C-13	21K482726	Ceramic, disc type: 10,000 mmf 450V.....	.30	R-9	6R2118	3.3 meg 20% 1/2W.....doz	1.20
C-14	21K691992	Ceramic, multiple: 2000 mmf, 100 mmf, 100 mmf, 5000 mmf.	.65	R-10	18A691993	Volume control: 1 meg.....	.80
Capacitor-Resistor				R-11	6R2109	10 meg 20% 1/2W.....doz	1.20
CR-1	21B601036	Capacitor-Resistor: 5000 mmf, 5000 mmf, 100 mmf, 100 mmf, 4.7 meg, 2.2 meg, 1 meg....	.65	R-12	6R6432	270 10% 1/2W.....doz	1.20
Choke Capacitor				R-13	6R6040	680 10% 1/2W.....doz	1.20
E-2	24K691986	Choke & .05 mf 200V paper capacitor.....	.40	R-14	6R5683	27 10% 1/2W.....doz	1.20
Rectifier				R-15	6R5554	390 10% 1/2W.....doz	1.20
E-1	48B791092	Selenium Rectifier: half-wave.....	1.40	R-16	6R2122	4.7 meg 20% 1/2W.....doz	1.20
Coils				R-17	6R6004	1 meg 20% 1/2W.....doz	1.20
L-1	1X610665	Antenna Loop & Front Cover Assembly: complete; green plastic (52M1U).....	5.25*	R-18	6R2118	3.3 meg 20% 1/2W.....doz	1.20
	1X610666	Antenna Loop, Panel & Hinge Assembly: less front cover; green plastic (52M1U).....	2.90*	Switches			
	24K601803	Antenna Loop & Panel Assembly: less hinges; green plastic (52M1U).....	1.40*	S-1	40B471927	Rotary Switch, 5 PDT (AC/DC-Battery selector).....	1.15
	1X610682	Antenna Loop & Front Cover Assembly: complete; maroon plastic (52M2U).....	5.25*	S-2	40K601702	Slide Switch (on-off).....	.50
	1X610683	Antenna Loop, Panel & Hinge Assembly: less front cover; maroon plastic (52M2U).....	2.90*	Transformers			
	24B601802	Antenna Loop & Panel Assembly: less hinges; maroon plastic (52M2U).....	1.40*	T-1	24K600824	IF Transformer, 455 Kc: complete with capacitors...	1.05
	1X611241	Antenna Loop & Front Cover Assembly: complete; gray plastic (52M3U).....	5.25*	T-2	24K600825	Diode Transformer, 455 Kc: complete with capacitor....	1.05
	1X611253	Antenna Loop, Panel & Hinge Assembly: less front cover; gray plastic (52M3U).....	2.90*	T-3	25K692006	Output Transformer.....	.95
	24K620032	Antenna Loop & Panel Assembly: less hinges; gray plastic (52M3U).....	1.40*	Part Number Description List Price			
L-2	24K610513	Oscillator coil (yellow code)	.85	CHASSIS PARTS - MECHANICAL			
				43A692011	Bushing, insulator: fibre (chassis mtg screw insulators)....doz		.40
				43A692012	Bushing, line cord strain relief (use with 43K692013).....		.05
				42K75826	Clip, electrolytic mtg.....doz		.40
				42A485548	Clip, IF transformer mtg.....doz		.20
				30K601777	Cord, line: with plug; 6 ft long..		.90
				29R3020	Lug, soldering: battery contact (in "A" battery retainer)....doz		.20
				9A470980	Receptacle, loop (on loop leads)doz		.25
				15B481896	Retainer, "A" battery: plastic....		.15
				43K692013	Retainer, strain relief bushing (on line cord bushing).....		.05
				26B692001	Shield, back (on rear of chassis).		.15

MODELS 52M1U, 52M2U,
52M3U, Ch. HS-300

Part Number	Description	List Price	Part Number	Description	List Price
26A692005	Shield heat (around R-3).....doz	.30	5S7770	Rivet: .088 x 5/32; stl; nkl pl (hinge insulator mtg).....per/c	.50
26B691996	Shield, switch (over AC/DC-Battery switch).....	.20	5S7786	Rivet: .088 x 3/16; stl; blk nkl (front hinge mtg).....per/c	.50
9A690129	Socket, tube: miniature; 7-prong..	.15	3S8144	Screw, self-tapping: #2 x 3/16; Phillips flat head; ant cop (mounts loop to front cover).....per/c	1.00
41K680029	Spring, battery contact (in "A" battery retainer).....doz	.20	3S400356	Screw, sheet metal: #4 x 1/4 hex head (chassis mtg).....per/c	.50
31K470880	Strip, "B" battery terminal: with leads.....	.40	3S2995	Screw, machine: 5-40 x 5/16 pl hex head (handle mtg).....per/c	.50
31K37504	Strip, terminal: 1 insulated lug, #1 mtg.....	.05	41A470909	Spring, door latch (inside front cover).....doz	.55
31K470746	Strip, terminal: 3 insulated lugs, #2 mtg.....	.05	41K692167	Spring, handle (inside plastic handle).....	.10
4K470939	Washer, fibre (R-3 mtg).....per/c	.50	2S7981	Speednut: for 1/8" stud (grille mtg).....doz	.15
MODEL 52M1U CABINET PARTS			41K601712	Spring, rear cover latch.....doz	.35
35B611249	Baffle, speaker: cardboard.....	.05	46A601807	Stud, front hinge mtg & loop connectors.....	.05
38B601741	Button, cover release (on front cover).....	.15	46A601726	Stud, latch retainer (front cover latch on grille).....	.10
38K692050	Button, plug: green finish (loop trimmer adj hole cover).....	.10	46K690079	Stud, trimount: blk nkl (on loop panel -for operating on-off switch).....	.25
1X610664	Cabinet: complete; less handle, grille and antenna loop and front cover assembly; green.....	7.55*	MODEL 52M2U CABINET PARTS - Same as Model 52M1U except:		
55A692058	Cover, handle mtg (over ends of handle).....	.40	38K600106	Button, plug: maroon finish (loop trimmer adj hole cover).....	.10
55A27113	Foot, cabinet bottom: felt.....doz	.60	1X610681	Cabinet: complete, less handle, grille and antenna loop and front cover assembly; maroon.....	7.55*
1X610667	Front Cover Assembly: complete; less loop; green plastic.....	1.90	1X610684	Front Cover Assembly: complete, less loop; maroon plastic.....	1.90
1X610668	Grille Assembly: complete with latch retainer stud, upper & lower speaker grilles.....	2.20	55K600107	Handle, carrying: maroon plastic; less spring.....	.20
13A610656	Grille, speaker (upper).....	.10	5S2828	Rivet: .088 x 3/16; stl; statuary bronze (front cover hinge mtg).....per/c	.50
13B610657	Grille, speaker (lower).....	.20	46K680035	Stud, trimount: statuary bronze (on loop panel -for operating on-off switch).....doz	.25
55K692166	Handle, carrying: green plastic; less spring.....	.20	MODEL 52M3U CABINET PARTS - Same as Model 52M1U except:		
55C601756	Hinge, front cover: complete; left-hand.....	1.30	38K611116	Button, plug: gray finish (loop trimmer adj hole cover).....	.10
55K601757	Hinge, front cover: complete; right-hand.....	1.30	1X611139	Cabinet: complete, less handle, grille and loop antenna and front cover assembly; gray.....	7.55*
55K30198	Hinge, rear cover.....doz	.25	1X611254	Front Cover Assembly: complete less loop; gray plastic.....	1.90
14A601753	Insulator, cap: plastic (on grille assembly lugs).....	.05	55K692166	Handle, carrying: green plastic; less spring.....	.20
14A601752	Insulator, hinge.....	.05			
36C601724	Knob, control (tuning).....	.55			
36K601725	Knob, control (volume).....	.55			
1X601765	Latch and Plate Assembly (inside front cover).....	.30			
4S8406	Lockwasher, int: #2 (loop)..per/c	.50			
4S7695	Lockwasher, int: #5 (handle mtg).....per/c	.50			
29R5399	Lug, soldering (under front hinge, for loop connection).....per/c	.50			
64C610735	Plate, background (behind control knobs).....	.55			
64A692191	Plate, handle mtg (under handle mtg covers).....doz	.35			
5S8487	Rivet: .088 x 3/32; stl; blk nkl (rear cover hinges & latch spring mtg).....per/c	.50			

PRICES SUBJECT TO CHANGE WITHOUT NOTICE
*Plus Federal Excise Tax At Current Rate

MODELS 72XM21,
72XM22, Ch. HS-303

GENERAL INFORMATION

TYPE - FM-AM table model receiver

TUNING RANGE - AM 535 to 1620 Kc IF - 455 Kc
FM 88 to 108 Mc IF - 10.7 McTUBE COMPLEMENT - 12BA6 - FM-AM RF Amplifier
12BA7 - FM-AM Converter
12BA6 - FM-AM IF Amplifier
12BA6 - FM IF Amplifier
19T8 - FM Ratio Detector, AM
Detector & 1st Audio Amp
50C5 - Power Amplifier
Rectifier - Selenium type

POWER SUPPLY - 117V AC or DC, 40 watts

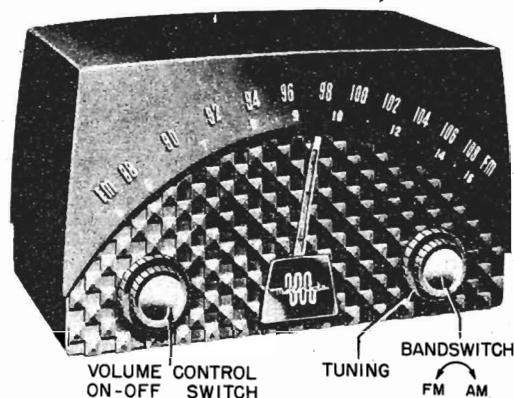

INSTALLATION & OPERATING INSTRUCTIONS

ANTENNA & GROUND

No outside antenna or ground is required for standard broadcast (AM) reception. A loop antenna for broadcast reception is located at the rear of the cabinet.

An FM antenna, built into the power cord, eliminates the need for an external FM antenna when the receiver is used in normal FM service areas such as are found in and for a few miles around metropolitan areas. In 'fringe' or weak signal areas, improved FM reception can be obtained by using an FM antenna mounted as high as possible. The FM antenna should be connected through a 300 ohm twin transmission line to the two screws on the rear of the set. Refer to the instructions on the antenna panel for proper transmission line connections. Orient the antenna so that maximum volume of FM station or stations is obtained.

NOTE: When the built-in FM antenna is used, connect the green lead from the chassis to the RIGHT-HAND terminal on the loop. Since the FM antenna is incorporated in the power line cord, stretch the line cord to its full length to obtain strong FM reception.

CAUTION: Do not connect antenna or chassis to water pipe, radiator, or other ground.

CONTROLS

POWER SWITCH & VOLUME CONTROL. The power switch and volume control are combined and are operated by the left-hand knob.

BANDSWITCH. The small (inner) right-hand knob selects FM or AM reception. Rotate the knob clockwise for AM or counterclockwise for FM.

TUNING. Tuning of both FM and AM is accomplished with the large (outer) right-hand knob. The standard broadcast dial (AM) is read in kilocycles by adding two zeros to the figures. The frequency modulation (FM) dial scale is read in megacycles (88 to 108).

Tuning of FM stations should be done very carefully, for best sound reproduction, not necessarily for strongest volume received.

SERVICE NOTES

OPERATING NOTES:

The chassis of this receiver is connected directly to the power line. When operating the chassis (from AC line) outside of its cabinet, use an isolation transformer between the power line and the receiver to reduce the possibility of electrical shock. If an isolation transformer is not available, check the AC voltage between the chassis and the bench ground. If there is any indication of voltage, reverse the line plug before handling the set.

When operating the receiver from an AC power line, reception can sometimes be improved by reversing the plug in the power outlet. If the receiver does not operate from a DC power line, after being turned on for a few minutes, reverse the plug in the power outlet.

TO CALIBRATE DIAL:

1. Turn the tuning knob counterclockwise until the end of its travel is reached.
2. Through the hole in the bottom of the cabinet, loosen the Allen head setscrew in the pointer sleeve.
3. Move the pointer until it coincides with the center of the "5" on the AM broadcast scale.
4. Tighten the setscrew.

NOTE: If the pointer is accidentally moved

by hand, it will be released from a detent in the pointer collar assembly, and no damage to the tuning mechanism will result. To reset the pointer, merely move it back and forth until it again engages in the detent.

TO REMOVE CHASSIS FROM CABINET:

1. Remove the pointer, as described above.
2. Pull off the control knobs.
3. From the rear of the cabinet, remove the two screws holding the chassis to the cabinet.
4. Remove the two split plugs at the top of the loop, which hold the loop to the cabinet.
5. Slide the chassis from the cabinet.

TO REMOVE POINTER:

1. Remove the two screws holding the medallion, from beneath the cabinet.
2. Turn the tuning knob until the pointer reaches the low frequency end of its range.
3. Through the hole in the bottom of the cabinet, insert an Allen head wrench into the setscrew in the pointer sleeve and hold the wrench. This keeps the sleeve from turning and breaking the dial string.
4. Remove the nut and washers from the front of the pointer.
5. Pull off the pointer.

MODELS 72XM21,
72XM22, Ch. HS-303

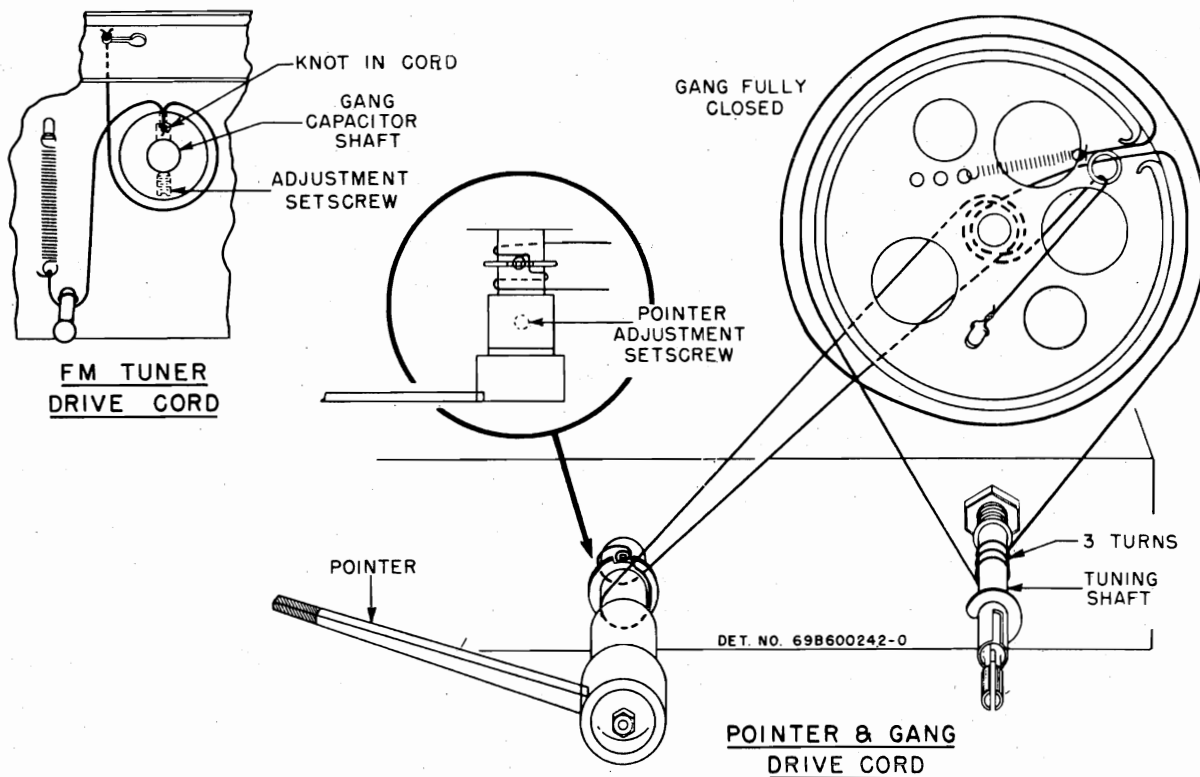

FIGURE 1. STRING DRIVE DETAIL

ALIGNMENT

GENERAL INFORMATION

1. Maximum performance can be obtained only if extreme care is exercised during alignment.
2. If AC power is used, it is recommended that an isolation transformer be placed between the power line and the receiver during alignment to avoid hum and electrical shocks. If an isolation transformer is not available, connect the low side of the signal generator to the receiver chassis through a .1 mf capacitor.
3. Use a small fibre screwdriver for aligning the IF transformers.
4. Refer to Figure 2 for the location of all alignment trimmers and cores.
5. As the stages are brought into alignment, reduce the signal generator output to a low value to avoid overloading the receiver.

ORDER OF ALIGNMENT AND EQUIPMENT REQUIRED

1. Broadcast Band IF & RF Alignment
 - a. 455 to 1620 Kc AM signal generator
 - b. Low range output meter
- 2 (A) FM Band IF & RF Alignment (Preferred Method)
 - a. 10.7 to 108 Mc FM signal generator
 - b. Oscilloscope
- (B) FM Band IF & RF Alignment (Alternate Method)
 - a. 10.7 to 108 Mc signal generator (unmod.)
 - b. Low range DC electronic voltmeter.

BROADCAST BAND - IF & RF ALIGNMENT

1. Connect the AM signal generator as in chart below, with 400 cycle, 30% modulation.
2. Connect the output meter across the speaker voice coil. Throughout alignment reduce the generator output to a level which produces less than .40 volts across the voice coil, to avoid overloading the receiver.
3. Set the bandswitch to the AM position.
4. Turn the receiver volume control to maximum.
5. Proceed as shown in the following chart.

MODELS 72XM21,
72XM22, Ch. HS-303

STEP	DUMMY ANTENNA	GENERATOR CONNECTION	GENERATOR FREQUENCY	GANG SETTING	ADJUST	REMARKS
IF ALIGNMENT						
1.	.1 mf	Grid of conv. V-2 (pin 7, 12BA7)	455 Kc	Fully opened	1, 2, 3 & 4 (IF cores)	Adjust for maximum.
RF ALIGNMENT						
2.	.1 mf	Grid of conv. V-2 (pin 7, 12BA7)	1620 Kc	Fully opened	5 (BC osc)	Adjust for maximum.*
3.		Across radiation loop**	1400 Kc	Tune in signal	8 (BC ant)	Adjust for maximum.

4. If, after the receiver has been aligned as above, it is found to be badly off calibration, it will be necessary to adjust oscillator core (7) as follows: connect the generator to the grid of the converter tube and, with the gang fully closed, adjust core (7) at 535 Kc. It is advisable to repeat the oscillator adjustments at 1620 Kc and 535 Kc several times until the tuning range is correct. Core (7) has been pre-set at the factory and normally should require no retuning.

* If difficulty is encountered in tuning trimmer (5), adjust trimmer (6) to 1/2 turn from tight.

**Connect generator output across 5" diameter, 5 turn loop and couple inductively to receiver loop. Keep loops at least 12" apart.

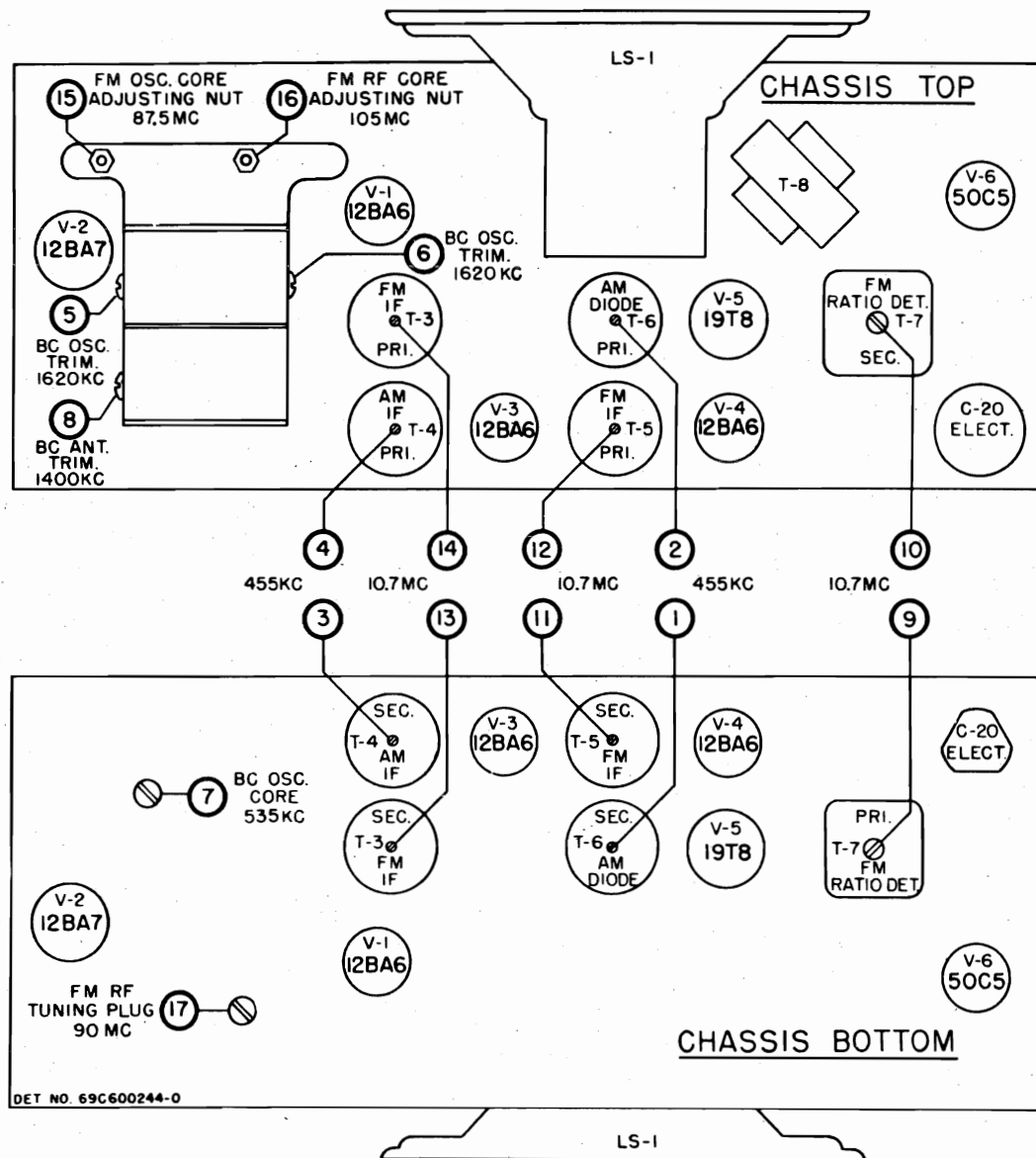

FIGURE 2. TUBE & TRIMMER LOCATIONS

MODELS 72XM21,
72XM22, Ch. HS-303 FM BAND - IF & RF ALIGNMENT (PREFERRED METHOD)

1. The following FM alignment procedure, using an FM signal generator and an oscilloscope, is to be preferred because the actual response pattern may be observed on the scope and adjusted for best symmetry and maximum amplitude.

2. Connect the vertical input terminals of the oscilloscope between the chassis and the junction of resistor R-24 (33K) and capacitor C-29 (1000 mmf)

3. Connect the FM signal generator sync voltage output terminals, through a phase shifting network, to the horizontal input terminals of the scope, as in Figure 3. (Other values of resistance and capa-

citance may be required, depending upon the scope). The phasing control should be adjusted to give only one trace on the scope. NOTE: If the FM generator has a built-in phase control, the phase shifting network is not necessary.

4. Set the bandswitch to the FM position.

5. Throughout alignment, reduce the generator output to keep the signal just above the noise level, to avoid overloading the receiver.

6. Proceed as shown in the following chart.

STEP	DUMMY ANTENNA	GENERATOR CONNECTION	GENERATOR FREQUENCY	TUNER SETTING	ADJUST	REMARKS
IF ALIGNMENT						
1.	1000 mmf	Grid of 2nd IF Amp V-4 (pin 1, 12BA6)	10.7 Mc ± 100 Kc dev.	Fully opened	9 (ratio det pri)	Adjust for maximum amplitude of pattern.*
2.	1000 mmf	Grid of 2nd IF Amp V-4 (pin 1, 12BA6)	10.7 Mc ± 100 Kc dev.	Fully opened	10 (ratio det sec)	Adjust for symmetrical curve, as shown in Figure 4.
3.	-	-	-	-	-	Repeat steps 1 & 2 for maximum amplitude and best symmetry.
4.	1000 mmf	Grid of 1st IF Amp V-3 (pin 1, 12BA6)	10.7 Mc ± 100 Kc dev	Fully opened	11 & 12 (2nd IF sec & pri)	Adjust for maximum amplitude of pattern.*
5.	1000 mmf	Grid of conv. V-2 (pin 7, 12BA7)	10.7 Mc ± 100 Kc dev	Fully opened	13 & 14 (1st IF sec & pri)	Adjust for maximum amplitude of pattern.*
6.	1000 mmf	Grid of conv. V-2 (pin 7, 12BA7)	10.7 Mc ± 100 Kc dev	Fully opened	11, 12, 13 & 14	Readjust for maximum amplitude and best symmetry.
RF ALIGNMENT						
7.	270 ohms	FM terminals on loop	87.5 Mc ± 22½ Kc dev	Fully closed	15 (osc adj nut)	Adjust for maximum amplitude of pattern.*
8.	-	-	-	Fully closed	16 (RF adj nut)	Turn counterclockwise until core is at bottom of pipe, then turn four turns clockwise.
9.	270 ohms	FM terminals on loop	90 Mc ± 22½ Kc dev	Tune in signal	17 (RF tuning plug)	Adjust for maximum amplitude of pattern.*
10.	270 ohms	FM terminals on loop	105 Mc ± 22½ Kc dev	Tune in signal	16 (RF adj nut)	Adjust for maximum amplitude of pattern.*
11.	-	-	-	-	-	Repeat steps 9 & 10 until no further adjustment is necessary.

*An output meter across the speaker voice coil will also indicate maximum amplitude. It should not be used in place of the scope, however, since it will not show symmetry of the curve.

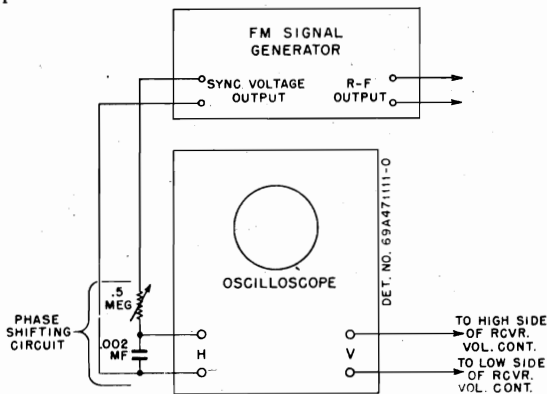

FIGURE 3.

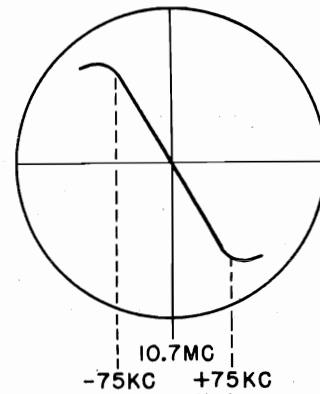

FIGURE 4.

FM SIGNAL GENERATOR & OSCILLOSCOPE HOOK-UP

RATIO DETECTOR WAVEFORM

FM BAND - IF & RF ALIGNMENT (ALTERNATE METHOD)

1. The following procedure for FM alignment, with an unmodulated carrier generator and a DC electronic voltmeter, is not as desirable as the preceding method; but it may be used if no FM generator is available.
2. Connect the signal generator as in chart below, with no modulation.
3. Set the bandswitch to the FM position.
4. Except in step 2 below, connect the electronic voltmeter across resistor R-23 (15K) in the ratio detector stage.

5. Throughout alignment reduce the signal generator output to a value which produces no more than a 5 volt rise above no signal voltage, to avoid overloading the receiver.
6. In step 2 below, connect two 100K ohm resistors in series across R-23. Connect the electronic voltmeter between the volume control side of resistor R-24 (33K) and the junction of the two 100K resistors, with the low side of the meter at the 100K resistors.
7. Proceed as shown in the following chart.

STEP	DUMMY ANTENNA	GENERATOR CONNECTION	GENERATOR FREQUENCY	TUNER SETTING	ADJUST	REMARKS
IF ALIGNMENT						
1.	1000 mmf	Grid of conv. V-2 (pin 7, 12BA7)	10.7 Mc	Fully opened	9, 11, 12, 13 & 14 (IF cores)	Adjust for maximum.
2.	1000 mmf	Grid of conv. V-2 (pin 7, 12BA7)	10.7 Mc	Fully opened	10 (ratio det sec)	Adjust for zero. (Connect meter as in step 6 above).
RF ALIGNMENT						
3.	270 ohms	FM terminals on loop	87.5 Mc	Fully closed	15 (osc adj nut)	Adjust for maximum.
4.	-	-	-	Fully closed	16 (RF adj nut)	Turn counterclockwise until core is at bottom of pipe, then turn four turns clockwise.
5.	270 ohms	FM terminals on loop	90 Mc	Tune in signal	17 (RF tuning plug)	Adjust for maximum.
6.	270 ohms	FM terminals on loop	105 Mc	Tune in signal	16 (RF adj nut)	Adjust for maximum.
7.	-	-	-	-	-	Repeat steps 5 & 6 until no further adjustment is necessary.

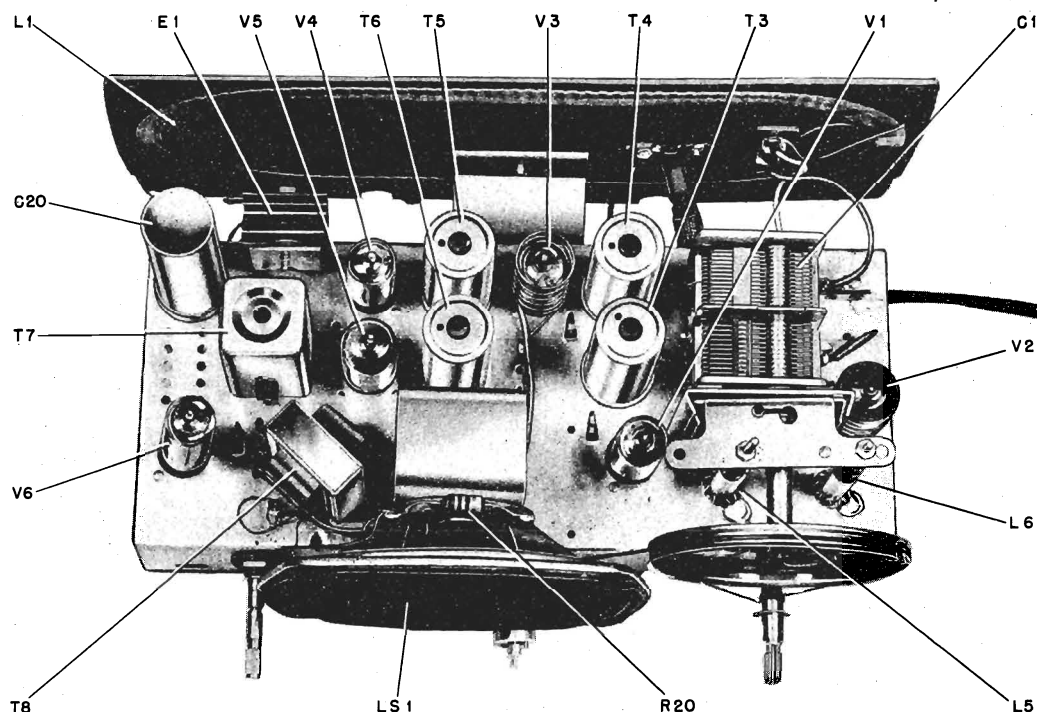

MODELS 72XM21,
72XM22, Ch. HS-303

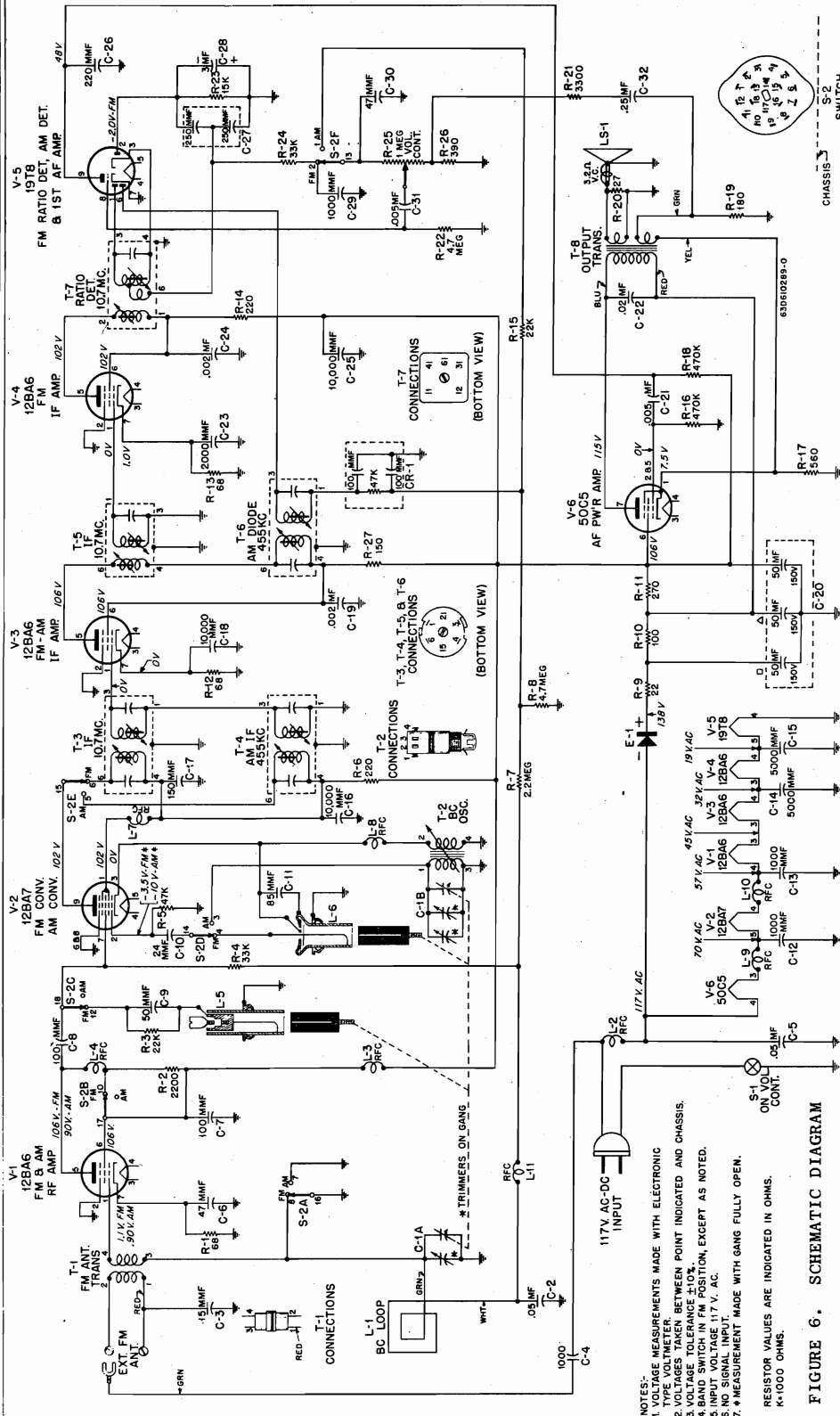

Part Number	Description	List Price
SUPPLEMENT NO. 1		
(Supplement to HS-303 Service Manual, Part No. 68P620310)		
GENERAL INFORMATION		
<p>Model 72XM22 is the same as 72XM21 except for the number of set in addition to part number and description of cabinet color and knobs which are listed below. The re- part. The following parts are revisions of or additions to maining chassis parts and cabinet parts are the same as the original items listed in the HS-303 Service Manual.</p>		
PARTS LIST SUPPLEMENT		
NOTE: When ordering parts, specify model and chassis		
36K621700	Knob, control: dark gray (tuning)	.20
36K621698	Knob, control: dark gray (on-off-volume)	.60
16K621701	Cabinet, table model: plastic; metallic -brown	11.80*
36K621699	Knob, control: dark gray (band-switch)	.35
CABINET PARTS		
PRICES SUBJECT TO CHANGE WITHOUT NOTICE		
*Plus Federal Excise Tax At Current Rate		

FIGURE 6. SCHEMATIC DIAGRAM

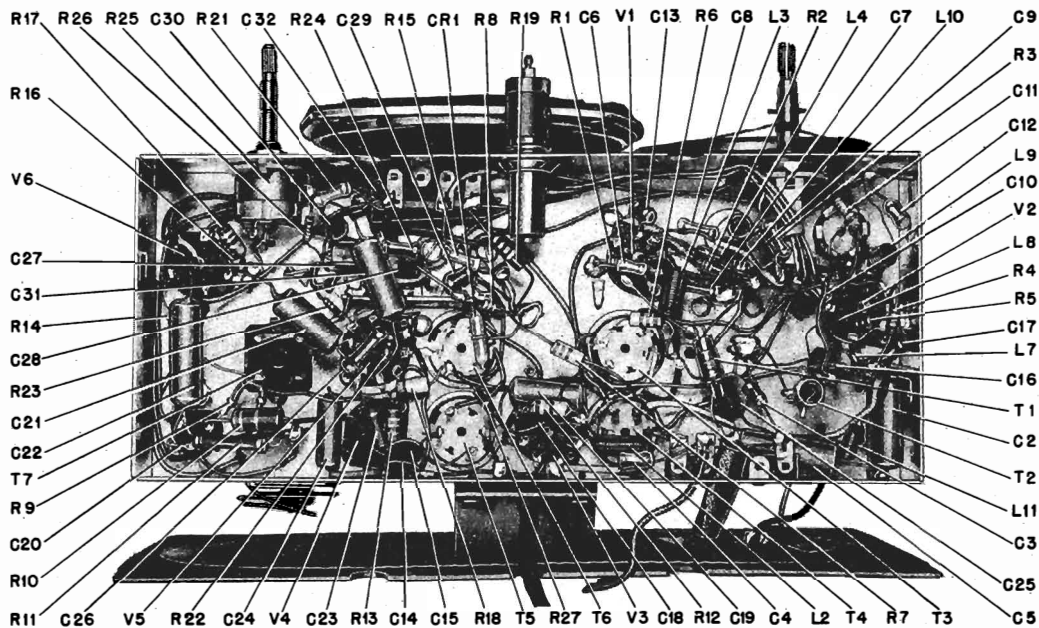

FIGURE 5. PARTS LOCATIONS

PARTS LIST

NOTE: When ordering parts, specify model number of set in addition to part number and description of part.

Ref. No.	Part Number	Description	List Price	Ref. No.	Part Number	Description	List Price
CHASSIS HS-303 PARTS - ELECTRICAL							
Capacitors							
C-1A,B	19B691877	Variable: 2-gang.....	3.00	Speaker			
C-2	8R9821	Paper: .05 mf 200V.....	.20	LS-1	50C692180		
C-3	21K470323	Ceramic: 15 mmf 500V.....	.25	or	50K610050	Speaker: 5-1/4" PM; 3.2 ohm VC.....	4.20*
C-4	21K478410	Ceramic: 1000 mmf 500V.....	.25	exch 3.15			
C-5	8K470606	Paper: .05 mf 400V.....	.25				
C-6	21K77373	Ceramic: 47 mmf 500V.....	.20	Resistors			
C-7	21B77286	Ceramic: 100 mmf 500V.....	.20	Note: All resistors are insulated carbon type unless otherwise specified.			
C-8	21B77286	Ceramic: 100 mmf 500V.....	.20	R-1	6R2039	68 10% 1/2W.....doz	1.20
C-9	21R2743	Mica: 50 mmf 5% 300V.....	.25	R-2	6R6069	2200 10% 1/2W.....doz	1.20
C-10	21R114992	Ceramic: 24 mmf 500V.....	.25	R-3	6R6028	22,000 20% 1/2W.....doz	1.20
C-11	21A690688	Ceramic: 85 mmf 500V.....	.30	R-4	6R6012	33,000 20% 1/2W.....doz	1.20
C-12	21K478410	Ceramic: 1000 mmf 500V.....	.25	R-5	6R6056	47,000 20% 1/2W.....doz	1.20
C-13	21K478410	Ceramic: 1000 mmf 500V.....	.25	R-6	6R3933	220 20% 1/2W.....doz	1.20
C-14	21A470789	Ceramic, disc type: 5000 mmf 450V.....	.30	R-7	6R3927	2.2 meg 20% 1/2W.....doz	1.20
C-15	21A470789	Ceramic, disc type: 5000 mmf 450V.....	.30	R-8	6R2122	4.7 meg 20% 1/2W.....doz	1.20
C-16	21K482726	Ceramic, disc type: 10,000 mmf 450V.....	.30	R-9	17A690578	Wire wound: 22 10% 1.5W.....	.20
C-17	21K691948	Ceramic: 150 mmf 500V.....	.20	R-10	6R3963	100 10% 2W.....	.25
C-18	21K482726	Ceramic, disc type: 10,000 mmf 450V.....	.30	R-11	6R476116	270 10% 2W.....	.20
C-19	8K9824	Paper: .002 mf 400V.....	.20	R-12	6R2039	68 10% 1/2W.....doz	1.20
C-20	23B690539	Electrolytic: 50-50-50 mf/150V.....	1.65	R-13	6R2039	68 10% 1/2W.....doz	1.20
C-21	8R9813	Paper: .005 mf 600V.....	.20	R-14	6R3933	220 20% 1/2W.....doz	1.20
C-22	8R9802	Paper: .02 mf 400V.....	.20	R-15	6R6028	22,000 20% 1/2W.....doz	1.20
C-23	21K790912	Ceramic: 2000 mmf 500V.....	.20	R-16	6R6032	470,000 20% 1/2W.....doz	1.20
C-24	8K9824	Paper: .002 mf 400V.....	.20	R-17	6R6291	560 10% 1/2W.....doz	1.20
C-25	21K482726	Ceramic, disc type: 10,000 mmf 450V.....	.30	R-18	6R6032	470,000 20% 1/2W.....doz	1.20
C-26	21K77375	Ceramic: 220 mmf 500V.....	.20	R-19	6R5660	180 10% 1/2W.....doz	1.20
C-27	21B484337	Ceramic, dual: 250 mmf, 250 mmf.....	.30	R-20	6R5683	27 10% 1/2W.....doz	1.20
C-28	23K690543	Electrolytic: 3 mf 50V.....	.65	R-21	6R6036	3300 20% 1/2W.....doz	1.20
C-29	21K478410	Ceramic: 1000 mmf 500V.....	.25	R-22	6R2122	4.7 meg 20% 1/2W.....doz	1.20
				R-23	6R6477	15,000 10% 1/2W.....doz	1.20
				R-24	6R6012	33,000 20% 1/2W.....doz	1.20
				R-25	18A690549	Volume control: 1 meg; with on-off switch.....	1.00
				R-26	6R5554	390 10% 1/2W.....doz	1.20
				R-27	6R6373	150 10% 1/2W.....doz	1.20

MODELS 72XM21,
72XM22, Ch. HS-303

Part Number	Description	List Price	Part Number	Description	List Price
C-30	21K77373 Ceramic: 47 mmf 500V.....	.20	14A482844	Insulator, line cord: fibre; with- out lugs.....doz	.25
C-31	8R9813 Paper: .005 mf 600V.....	.20	14K692187	Insulator, line cord: fibre; with lugs.....doz	.05
C-32	8R9810 Paper: .25 mf 100V.....	.25	2S7051	Nut, hex palnut: 3/8-32 x 9/16; cad pl (vol control & bandswitch mtg).....doz	.15
Capacitor-Resistor			1X692216	Pulley Assembly, pointer drive: 3-1/2" dia.....doz	.30
CR-1	21A473040 Capacitor-Resistor: 100-100 mmf & 47,000 ohms.....	.40	49A690562	Pulley, core drive: brass.....	.15
Rectifier			3S7103	Setscrew: 8-32 x 1/8 Allen head; cad pl (core drive pulley mtg)...	.10
E-1	48B482807 Rectifier, selenium: half- wave; 150 ma.....	1.90	3S9705	Setscrew: 8-32 x 1/4 Allen head; cad pl (pointer adj sleeve mtg)...	.10
Coils			1X692225	Shaft & Pulley Assembly, pointer: complete, but less pointer.....	1.10
L-1	24C692186 Antenna Loop & Panel Assembly: complete.....	1.25	47K690573	Shaft, tuning (fits over bandswitch shaft).....	.25
L-2	24A692148 RF choke.....	.20	26A610579	Shield, tube (for V-2)(also order 27A610586).....	.10
L-3	24A692148 RF choke.....	.20	9K484167	Socket, tube: miniature; 7-prong (for V-3,4 & 6).....	.20
L-4	24A484025 RF choke.....	.20	9K610589	Socket, tube: miniature; 7-prong (for V-1).....	.15
L-5	24C690584 Inductor & Capacitor Assem- bly: FM RF; less tuning core	1.35	9B692196	Socket, tube: noval; 9-prong (for V-5).....	.15
L-6	24K600519 Inductor & Capacitor Assem- bly: FM osc; less tuning core.....	1.50	9K692197	Socket, tube: noval; 9-prong (for V-2).....	.15
L-7	24A691847 RF choke.....	.05	41A690598	Spring, coil: 7 turns; cosmoline dipped (FM RF core mtg).....doz	.15
L-8	24A791081 RF choke.....	.20	41K691840	Spring, coil: 8 turns; copper plated (FM osc core mtg).....doz	.20
L-9	24A692148 RF choke.....	.20	41A14244	Spring, tension (core & pointer drive cord).....doz	.55
L-10	24K780128 RF choke.....	.20	4A73639	Washer, "C" (holds tuning shaft).....doz	.20
L-11	24A791081 RF choke.....	.20	4A70873	Washer, fibre (pointer drive cord spacer on gang shaft).....doz	.15
Switches			4K690571	Washer, shoulder: fibre (vol con- trol & bandswitch mtg).....doz	.20
S-1	- On-Off Switch (on vol control)	-	4K482859	Washer, shoulder: fibre (loop mtg brkt).....doz	.15
S-2	40B690538 Bandswitch, AM-FM.....	1.15	MODEL 72XM21 CABINET PARTS		
Transformers			16K611099	Cabinet, table model: plastic; gray.....	6.55
T-1	24A690544 FM Antenna Input Transformer	.50	36K611097	Knob, control: gray plastic (tun- ing knob).....	.20
T-2	24K691878 BC oscillator coil.....	.50	36K611098	Knob, control: gray plastic (AM- FM selector).....	.35
T-3	24B690540 1st FM IF Transformer (orange dot): 10.7 mc; complete with capacitors and cores, less shield.....	1.60	36K611113	Knob, control: gray plastic (vol- ume control).....	.60
T-4	24B692193 AM IF Transformer (blue dot): 455 Kc; complete with capaci- tors and cores; less shield	1.15	4S7650	Lockwasher, internal: #6 (pointer mtg).....per/c	.50
T-5	24B690541 2nd FM IF transformer (yel- low dot): 10.7 mc; complete with capacitors and cores; less shield.....	1.60	2S7005	Nut, hex: 6-32 x 1/4 stl (pointer mtg).....per/c	.50
T-6	24B692193 AM Diode transformer (blue dot): 455 Kc; complete with capacitors and cores; less shield.....	1.15	13B692039	Medallion: brass plated.....	.90
T-7	24B690542 Ratio Detector Transformer: 10.7 mc; complete with capa- citors, cores, and shield..	2.00	38A25507	Plug, split (mounts loop to cabi- net).....doz	.15
T-8	25B690536 Audio Output Transformer....	1.25	52B692173	Pointer, dial.....	.35
CHASSIS HS-303 PARTS MECHANICAL			3S2999	Screw, machine: 6-32 x 5/8 slotted locking hex head (medallion mtg).....doz	.15
27A610586	Base, tube shield (for V-2)(also order 26A610579).....	.10	3S7316	Screw, machine: 8-32 x 3/8 slotted locking hex head (chassis mtg)doz	.15
42K690561	Clip, anti-backlash: single (on core mtg bracket).....	.05	4S1720	Washer, flat: 3/8 x .156 x .030 stl; (medallion mtg).....per/c	.50
42A690560	Clip, anti-backlash: double (on tuner mtg bracket).....	.05	4S1765	Washer, flat: 1/2 x .147 x .015 stl (pointer mtg).....per/c	.50
30K21859	Cord, line: with plug; 9 ft long..	1.00	4B600149	Washer, spring (pointer mtg).doz	
46K692165	Core, iron and screw (FM RF tuning core).....	.40			
46B692164	Core, iron and screw: green dot (FM osc tuning core).....	.40			
5A19658	Eyelet, speaker mtg.....doz	.20			
37A12691	Grommet, rubber (spkr cushion).doz	.35			
14A690548	Insulator, bakelite (vol control & bandswitch mtg).....	.05			

PRICES SUBJECT TO CHANGE WITHOUT NOTICE

*Plus Federal Excise Tax At Current Rate

GENERAL INFORMATION

TYPE - AC table model superheterodyne with appliance outlet and self-contained electric clock for controlling automatically the operation of the radio and the outlet.

RECEIVER MODELS	Model	Color
	52C6	Walnut
	52C7	Ivory
	52C8	Green

TUNING RANGE - 535 to 1620 Kc IF - 455 Kc

TUBE COMPLEMENT	Type	Function
	12BE6	Converter
	12BD6	IF Amplifier
	12AT6	Det, AVC & AF Amp
	50C5	Power Amplifier
	35W4	Rectifier

POWER SUPPLY - Operates from 117 volts, 60 cycle, alternating current only. Power consumption 37 watts.

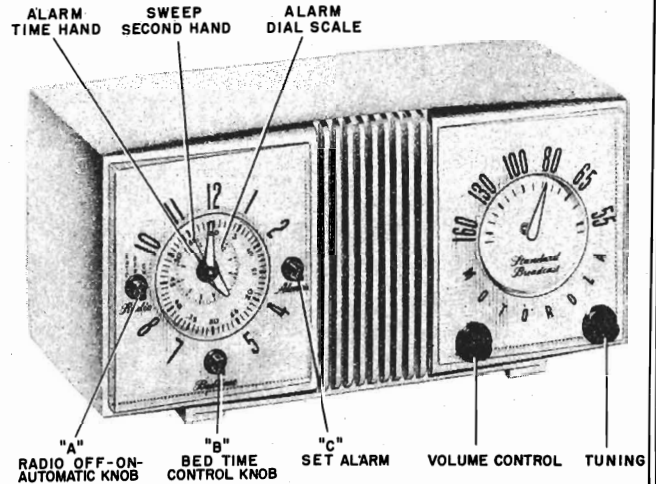

CLOCK - Telechron self-starting electric clock, with Motorola face and hands.

APPLIANCE OUTLET - For use with 117 volt AC appliances only, rated at 1100 watts or less.

OPERATING INSTRUCTIONS

The locations and functions of the clock and radio controls are shown in the photo above.

NORMAL RADIO OPERATION

Knob "A" on the clock turns the radio on or off. Select stations with the TUNING knob, and adjust volume with the VOLUME control.

A built-in loop antenna eliminates the need for an outside antenna in most locations. When receiving a weak station, rotate the receiver slightly for best signal strength. If additional pick-up is necessary, connect an external antenna to the radio by following the instructions printed on the rear panel. CAUTION: Never connect the radio chassis to a water pipe, radiator, or other ground.

CLOCK OPERATION

The clock will start as soon as the receiver is plugged into an electrical outlet. To set the hands to the correct time, rotate the TIME SET knob (on the rear of the radio)

in a clockwise direction only.

ALARM OPERATION

To set the alarm, pull out knob "C" and rotate it in a counterclockwise direction to the desired time on the alarm dial scale. The alarm will ring for one hour, or until knob "C" is pushed in. The alarm function is completely independent of the other controls on the clock.

APPLIANCE OUTLET

To control an electrical appliance automatically, plug it into the receptacle on the back of the radio. See Figure 1. It will then be turned on or off simultaneously with the radio. CAUTION: Note that the rating of the outlet is 1100 watts or less.

If radio reception is not desired when operating the appliance, rotate the radio volume control to the minimum volume position.

MODELS 52C6, 52C7, A,
52C8, Ch. HS-310

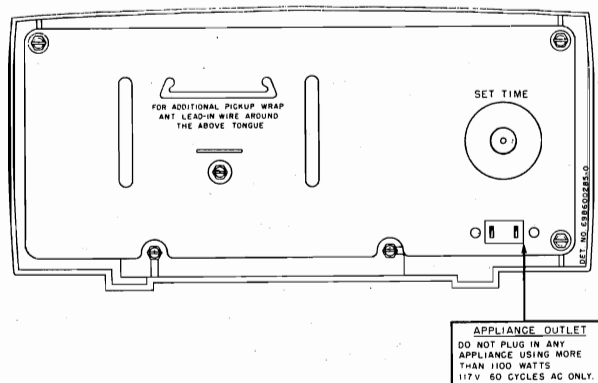

FIGURE 1. REAR VIEW

BEDTIME CONTROL

The BEDTIME control will turn the radio and appliance off after any pre-set interval of time up to one hour.

Turn knob "A" to the "OFF" position and rotate knob "B" to any period of time between 0 and 60 minutes. The radio and appliance will be turned off automatically after the proper time has elapsed, and they will remain off until turned on again manually.

AUTOMATIC RADIO OPERATION

The clock controls may be pre-set to turn the radio on automatically at any time up to twelve hours in advance.

If an appliance is plugged into the receptacle on the back of the receiver, it will be turned on automatically, along with the radio.

Pull out knob "C", rotate it counterclockwise to the desired time on the alarm dial scale, and push the knob back in. Rotate knob "A" first to the "OFF" and then to the "AUTO" position. At the pre-set time, the radio will come on and will continue to play until turned off manually. The alarm will ring also if the knob "C" is left pulled out. The radio will come on first and, after an interval of about ten minutes, the alarm will ring.

BEDTIME AND AUTOMATIC OPERATIONS COMBINED

By combining the operations in the two sections above, the radio may be turned off automatically and on again automatically.

When setting the BEDTIME control, rotate knob "A" to the "AUTO" position instead of "OFF". IMPORTANT: It is necessary to turn knob "A" first to the "OFF" position before proceeding to "AUTO", otherwise the radio may not shut off.

ALIGNMENT

NOTE: It is recommended that an isolation transformer be placed between the power line and the receiver to avoid hum and electrical shocks. If an isolation transformer is not available, connect the low side of the signal generator to B- through a .1 mf capacitor.

1. Connect a low range output meter across the speaker voice coil.
2. Connect the low side of the signal generator to B-.
3. Set the signal generator for 400 cycle, 30% modulation.

4. Turn the receiver volume control to maximum.
5. Use a small fibre screwdriver for aligning the IF and diode transformers.
6. As stages are brought into alignment, reduce the signal generator output to a level which produces less than .40 volts (.05 watt) across the voice coil to avoid overloading the receiver.
7. See Figure 2 for adjustment locations and the following chart for procedure.

ALIGNMENT CHART

STEP	DUMMY ANTENNA	GENERATOR CONNECTION	GENERATOR FREQUENCY	GANG SETTING	ADJUST	REMARKS
IF ALIGNMENT						
1.	.1 mf	Grid of conv. (pin 7, 12BE6)	455 Kc	Fully open	1, 2, 3 & 4 (IF cores)	Adjust for maximum.
RF ALIGNMENT						
2.	-	-	-	Fully closed	-	Set pointer to horizontal position.
3.	.1 mf	Grid of conv. (pin 7, 12BE6)	1620 Kc	Fully open	5 (Osc)	Adjust for maximum.
4.	-	Radiation loop*	1400 Kc	Tune for max	6 (Ant)	Adjust for maximum.

*Connect generator output across 5" diameter, 5 turn loop and couple inductively to receiver loop. Keep loops at least 12" apart.

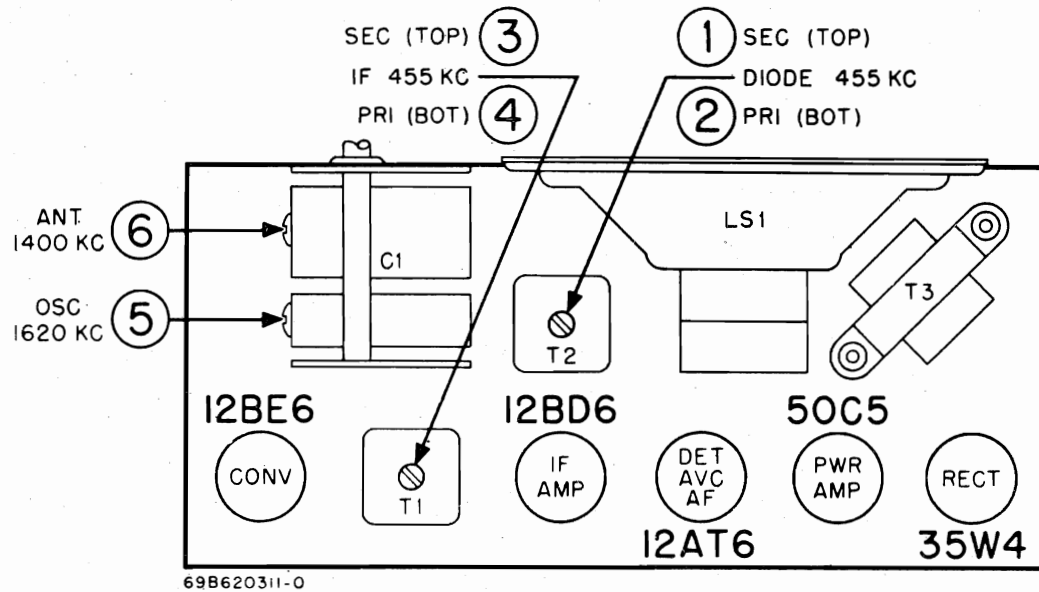

69B620311-0

FIGURE 2. TUBE AND TRIMMER LOCATION

SERVICE NOTES

TO REMOVE RADIO CHASSIS FROM CABINET

1. Pull off the two radio control knobs.
2. Remove the three hex head screws which hold the loop to the cabinet.
3. From the back of the cabinet, remove the two hex head screws at the rear edge of the radio chassis.
4. Slide the radio chassis and loop from the cabinet.
5. Disconnect the power leads to the radio chassis and to the appliance receptacle.

TO REMOVE CLOCK FROM CABINET

1. Remove the radio chassis as above.
2. Pull off the three clock control knobs.
3. From the back of the cabinet, remove the three hex head screws which hold the clock and its fibre insulator.
4. Carefully remove the clock, to prevent damage to its hands or face.

TO REPLACE CLOCK DIAL BACKGROUND

1. Remove the clock from the cabinet as above.
2. Carefully pull off the three hands.
3. Remove the alarm dial and dial background.

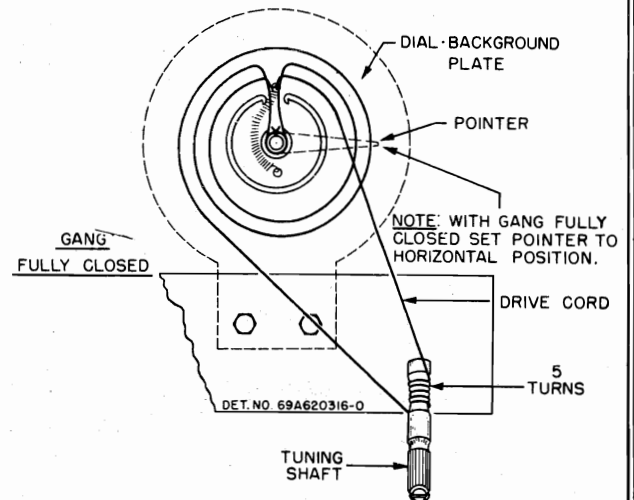

FIGURE 3. STRING DRIVE DETAIL

4. Install new background.
5. Turn the radio control shaft to "AUTO" position.
6. Slowly rotate the time set shaft clockwise until the switch contacts behind the radio control shaft close.
7. Reassemble the alarm dial and three hands. Set all the hands to indicate 12 o'clock. Set the figure "12" on the alarm dial to index with the small pointer on the hour hand.
8. Check the automatic operation to be sure the switch contacts close at the time indicated on the alarm dial.

MODELS 52C6, 52C7, A,
52C8, Ch. HS-310

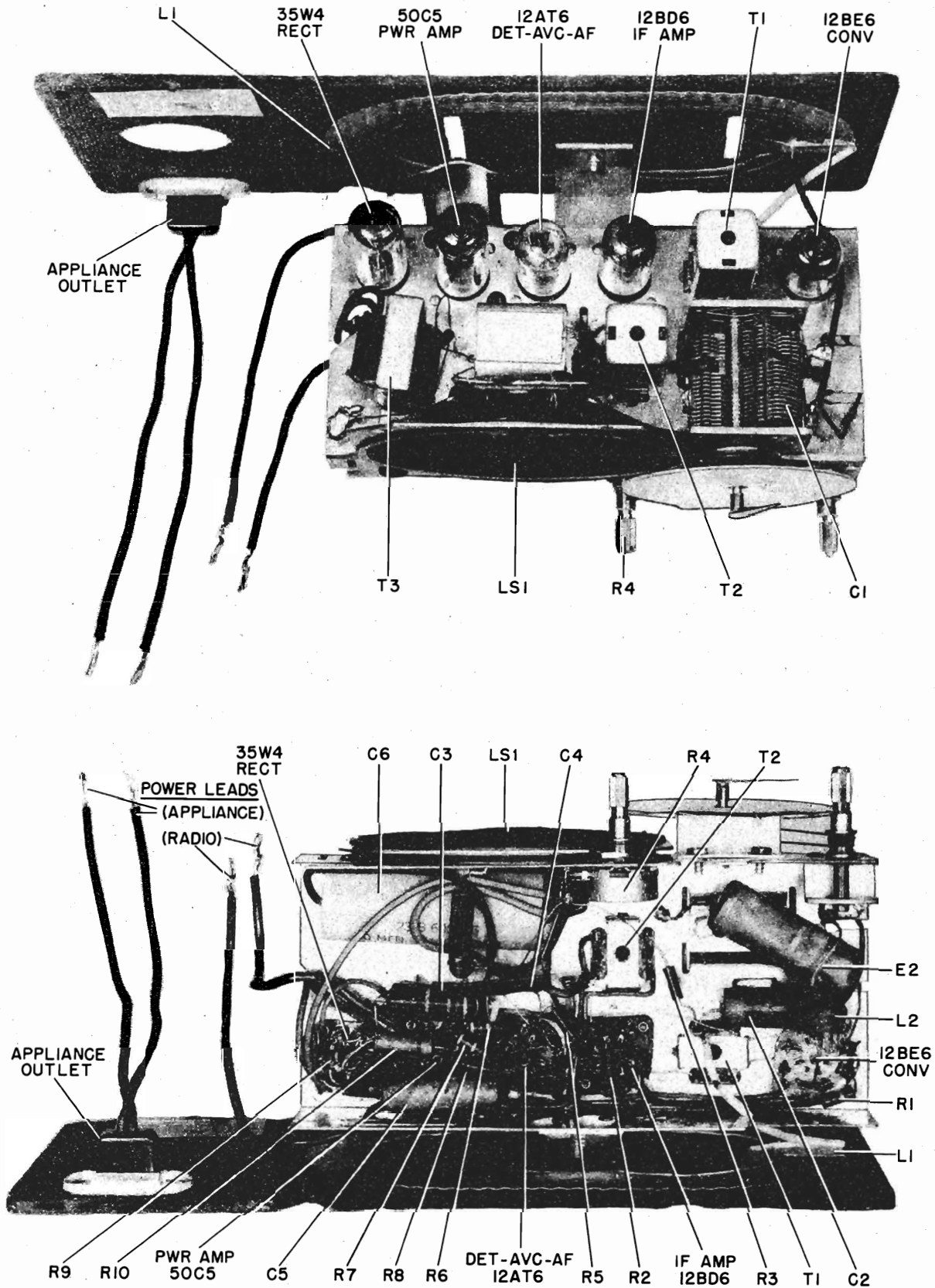

FIGURE 4. PARTS LOCATION

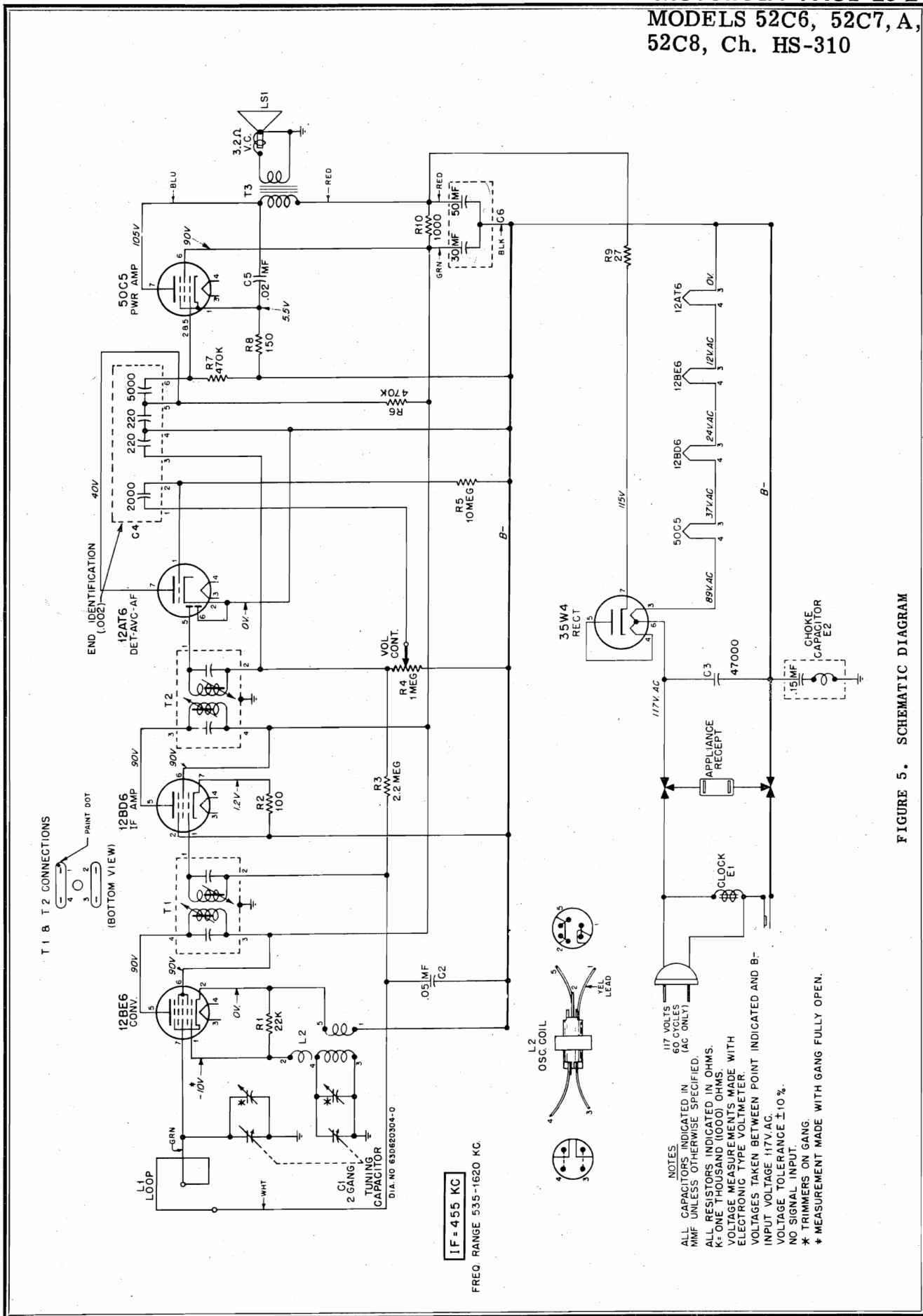

FIGURE 5. SCHEMATIC DIAGRAM

MODELS 52C6, 52C7, A,
52C8, Ch. HS-310

PARTS LIST

NOTE: When ordering parts, specify model and chassis numbers of set in addition to part number and description of part.

Ref. No.	Part Number	Description	List Price	Part Number	Description	List Price
CHASSIS PARTS - ELECTRICAL						
<u>Capacitors</u>						
C-1	19B610820	Variable: 2-gang; with pulley.....	2.85	5A484268	Grommet, speaker mtg: rubber...doz	.20
C-2	8R9821	Paper: .05 mf 200V.....	.20	14A478119	Insulator, loop brkt mtg:fibre.doz	.15
C-3	8R490232	Molded paper: 47,000 mmf 400V	.25	2S7051	Nut, hex palnut: 3/8-32 x 9/16 (vol- ume control mtg).....doz	.15
C-4	21B482847	Ceramic, multiple: 2000-220- 220-5000 mmf/400V.....	.65	35A601669	Pad, cushion: sponge rubber (spkr cushion).....	.10
C-5	8R9802	Paper: .02 mf 400V.....	.20	64B610782	Plate, radio dial background: silver color.....	.55
C-6	23B600855	Electrolytic: 50-30 mf/150V.	1.10	52A610809	Pointer, radio dial: light green..	.25
<u>Clock</u>						
E-1	59K610835	Electric Clock Assembly: Telechron; with hands; less line cord.....	11.95 exch 8.95	9A601018	Receptacle, appliance (on loop panel).....	.50
<u>Choke-Capacitor</u>						
E-2	8A690487	Choke and .15 mf paper capacitor.....	.30	1A610808	Shaft, tuning: with pulley.....	.15
<u>Coils</u>						
L-1	1X610854	Antenna Loop, Panel, and Receptacle Assembly: comp..	1.15	9K580218	Socket, tube: miniature; 7-prong; with dummy lug and center shield; wafer type.....	.15
L-2	24B680364	Oscillator coil.....	.90	41A73996	Spring, tension (electrolytic mtg)	.05
<u>Speaker</u>						
LS-1	50K610558 or 50K610557	Speaker: 4" PM; 3.2 ohm VC..	3.90* exch 2.95	41A73619	Spring, tension (gang drive cord)doz	.40
<u>Resistors</u>						
Note: All resistors are insulated carbon type unless otherwise specified.						
R-1	6R6028	22,000 20% 1/2W.....doz	1.20	4A70015	Washer, "C" (tuning shaft mtg)per/c	.50
R-2	6R6018	100 20% 1/2W.....doz	1.20	14A11493	Washer, shoulder: fibre (loop bracket mtg).....doz	.35
R-3	6R3927	2.2 meg 20% 1/2W.....doz	1.20	CABINET PARTS		
R-4	18A600018	Volume control: 1 meg.....	.80	1X610839	Cabinet, table model: walnut; less overlays and clock and radio scales (52C6).....	4.75*
R-5	6R2109	10 meg 20% 1/2W.....doz	1.20	1X610855	Cabinet, table model: ivory; less overlays and clock and radio scales (52C7).....	6.30*
R-6	6R6032	470,000 20% 1/2W.....doz	1.20	1X610856	Cabinet, table model: green; less overlays and clock and radio scales (52C8).....	6.30*
R-7	6R6032	470,000 20% 1/2W.....doz	1.20	28A600064	Connector, wire (connects clock & radio power leads).....	.05
R-8	6R3992	150 20% 1/2W.....doz	1.20	14B611368	Insulator, clock: fibre (over back of clock).....	.15
R-9	6R5683	27 10% 1/2W.....doz	1.20	36B610817	Knob, clock control: black.....	.20
R-10	6R3953	1000 20% 1W.....each	.20	36B610815	Knob, radio control: black.....	.20
<u>Transformers</u>						
T-1,2	24C485553	IF and diode transformer: 455 Kc; complete with capacitors, cores, and shield.....	.95	13K610803	Overlay, clock background: gold color.....	.10
T-3	25K680345	Output transformer.....	1.05	13A610804	Overlay, radio background: gold color.....	.10
<u>CLOCK PARTS</u>						
Note: The following Motorola parts are for use with Telechron clock movement, Part No. 59K610835.						
Part Number	Description	List Price	34K610826	Alarm dial: silver color.....	.40	
			42K601734	Clamp, line cord.....	.05	
			30K600980	Cord, line: with plug; 6 ft long..	.85	
			64K620049	Dial background: silver color....	.40	
			52K610836	Hand, hour: luminous.....	.40	
			52K610837	Hand, minute: luminous.....	.40	
			52K610829	Hand, second: black.....	.15	
			36K601002	Knob, time set.....	.20	
			59K610568	Motor, clock (rotor assembly only)	3.40	
CHASSIS PARTS - MECHANICAL						
7A478118	Bracket, loop mtg.....	.05				
7A77337	Bracket, tuning shaft.....	.05				
42B485548	Clip, IF trans mtg.....doz	.20				

PRICES SUBJECT TO CHANGE WITHOUT NOTICE
*Plus Federal Excise Tax At Current Rate

S U P P L E M E N T N O . 1

This manual contains a supplementary Replacement Parts List covering production revisions in the 52C6 series of receivers.

OUTPUT TRANSFORMER

An alternate output transformer, interchangeable with the original, has been added. Both transformers are listed below.

SPEAKER

Four alternate speakers have been added. All speakers are listed below.

DIAL BACKGROUND

In later production Model 52C7 receivers, the dial background color was changed from gold to silver. The color remains gold for Models 52C6 and 52C8.

PARTS LIST SUPPLEMENT

NOTE: When ordering parts, specify model number of set in addition to part number and description of part.

Part Number	Description	List Price	Part Number	Description	List Price	
25K680345 or 25B478121	Output Transformer.....	1.05	13K620201	Overlay, clock background: silver color (52C7) (replaces 13K610803 on late model 52C7).....	.20	
50K610558 or 50K610557 or 50C600017 or 50B610052 or 50C600857 or			13K620200			Overlay, radio background: silver color (52C7) (replaces 13A610804 on late model 52C7).....
50C610506			Speaker: 4" PM; 3.2 ohm VC.....	3.90*		
			exch	2.95		

PRICES SUBJECT TO CHANGE WITHOUT NOTICE
*Plus Federal Excise Tax At Current Rate

S U P P L E M E N T N O . 2

PARTS LIST SUPPLEMENT

NOTE: When ordering parts, specify model number of set in addition to part number and description of part.
The following parts are revisions of or additions to the original items listed in the HS-310 Service Manual.

GENERAL INFORMATION

Model 52C7A is the same as Model 52C7 except for styling. A complete listing of 52C7A cabinet parts is given below.

Refer to HS-310 Service Manual for service instructions, chassis replacement parts, and clock replacement parts.

Part Number	Description	List Price
CABINET PARTS		
1V621721	Cabinet, table model: ivory; with medallion; less overlays and clock & radio crystals.....	6.30*
61C621528	Crystal, plastic (clock face cover)	1.45
61K621529	Crystal, plastic (radio face cover)	.85
36K621520	Knob, clock control (black).....	.20
13K621670	Medallion (on spkr grille).....	.55
13K621669	Overlay, clock background: silver color.....	.80
13C621668	Overlay, radio background: silver color.....	.80
2S490840	Speednut: for 1/16" stud (medallion mtg).....doz	.15

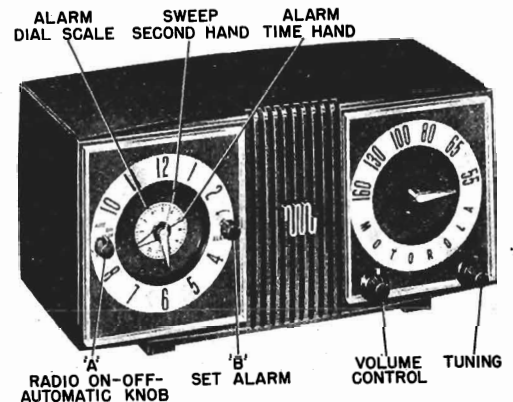

MODELS 52H11U, 52H12U,
52H13U, 52H14U, Ch. HS-313

GENERAL INFORMATION

TYPE - AC-DC table model superheterodyne receiver with loop antenna.

RECEIVER MODELS

Model	Color
52H11U	Walnut
52H12U	Ivory
52H13U	Green
52H14U	Gray

TUNING RANGE - 535 to 1620 Kc IF - 455 Kc

TUBE COMPLEMENT	Type	Function
	12BE6	Converter
	12BD6	IF Amplifier
	12AT6	Det, AVC & 1st AF Amp
	50C5	Power Amplifier
	35W4	Rectifier

POWER SUPPLY - 117 volts AC or DC, 35 watts

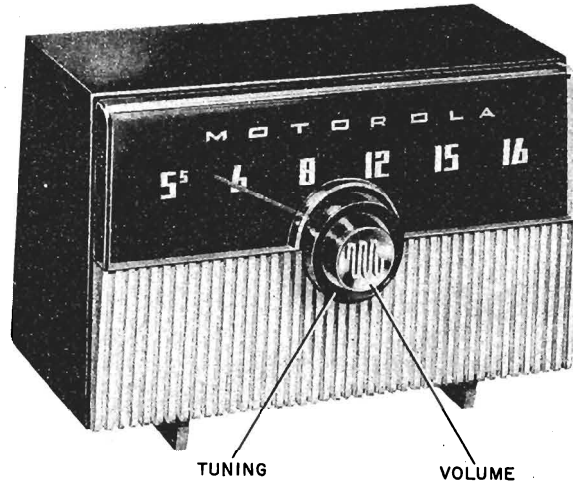

OPERATING INSTRUCTIONS

POWER SWITCH AND VOLUME CONTROL. Operated with the inner knob. NOTE: Reverse the line cord plug in the wall outlet if radio does not operate from DC. When operating from AC, reversing the line cord plug in the wall outlet may sometimes improve reception.

TUNING. Tune stations with the outer knob.

ANTENNA. A built-in loop antenna eliminates the need for an outside antenna in most locations. When receiving a weak station, rotate the receiver slightly for best signal strength. If additional pick-up is necessary, connect an external antenna to the radio by following the instructions printed on the rear panel. CAUTION: Never connect the radio chassis to a water pipe, radiator, or other ground.

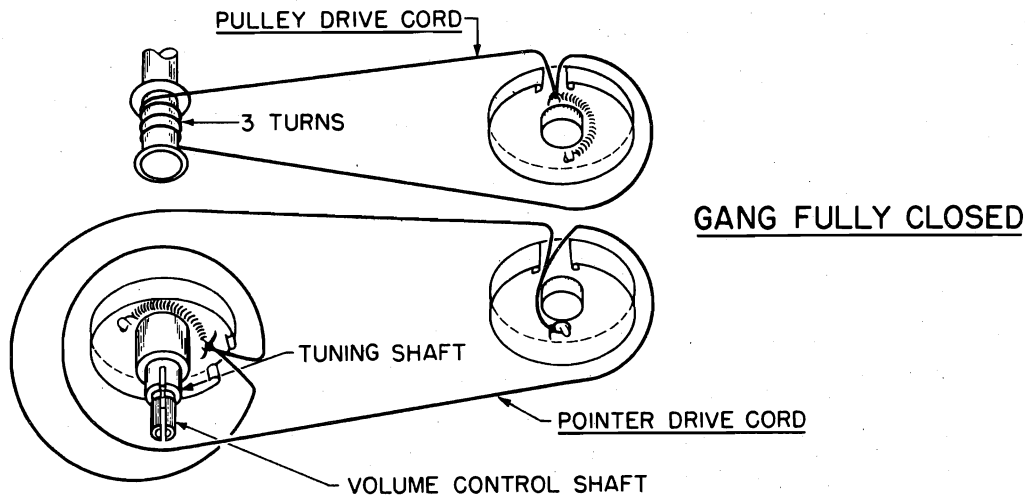

FIGURE 1. DIAL RESTRINGING DETAIL

SERVICE NOTES

The chassis of this receiver is isolated from the AC power line circuit by a capacitor to eliminate the shock hazard when handling the receiver. However, as an additional precaution when aligning or servicing the receiver from AC, an isolation transformer should be inserted between the power line and the chassis.

TO REMOVE CHASSIS FROM CABINET:

1. Pull off the two radio control knobs. A flat head screw holding the dial scale will be exposed.
2. Remove the flat head screw,

3. Remove the dial scale.
4. Pull off the pointer.
5. Remove the split plugs which hold the loop to the cabinet.
6. From the back of the cabinet, remove the two hex head screws at the rear edge of the radio chassis.
7. Slide the radio chassis and loop from the cabinet.

ALIGNMENT

NOTE: If AC power is used, it is recommended that an isolation transformer be placed between the power line and the receiver to avoid hum and electrical shocks. If an isolation transformer is not available, connect the low side of the signal generator to B- through a .1 mf capacitor.

1. Connect a low range output meter across the speaker voice coil.
2. Connect the low side of the signal generator to B-.
3. Set the signal generator for 400 cycle, 30% modulation.

4. Turn the receiver volume control to maximum.
5. Use a small fibre screwdriver for aligning the IF and diode transformers.
6. As stages are brought into alignment, reduce the signal generator output to a level which produces less than .40 volts (.05 watt) across the voice coil to avoid overloading the receiver.
7. See Figure 2 for adjustment locations and the following chart for procedure.

ALIGNMENT CHART

STEP	DUMMY ANTENNA	GENERATOR CONNECTION	GENERATOR FREQUENCY	GANG SETTING	ADJUST	REMARKS
IF ALIGNMENT						
1.	.1 mf	Grid of conv. (pin 7, 12BE6)	455 Kc	Fully open	1, 2, 3 & 4 (IF cores)	Adjust for maximum.
RF ALIGNMENT						
2.	.1 mf	Grid of conv. (pin 7, 12BE6)	1620 Kc	Fully open	5 (Osc)	Adjust for maximum.
3.	-	Radiation loop*	1400 Kc	Tune for max	6 (Ant)	Adjust for maximum.

*Connect generator output across 5" diameter, 5 turn loop and couple inductively to receiver loop. Keep loops at least 12" apart.

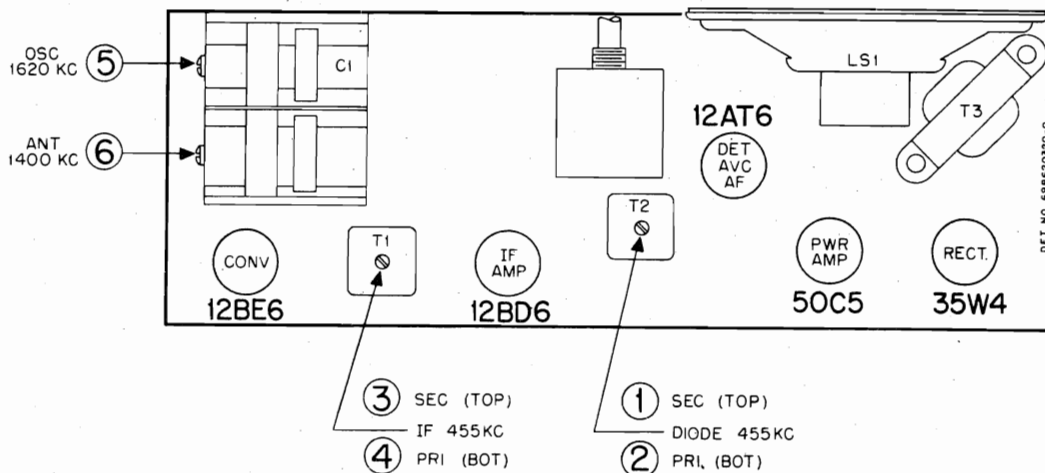

FIGURE 2. TUBE AND TRIMMER LOCATIONS

MODELS 52H11U, 52H12U,
52H13U, 52H14U, Ch. HS-313

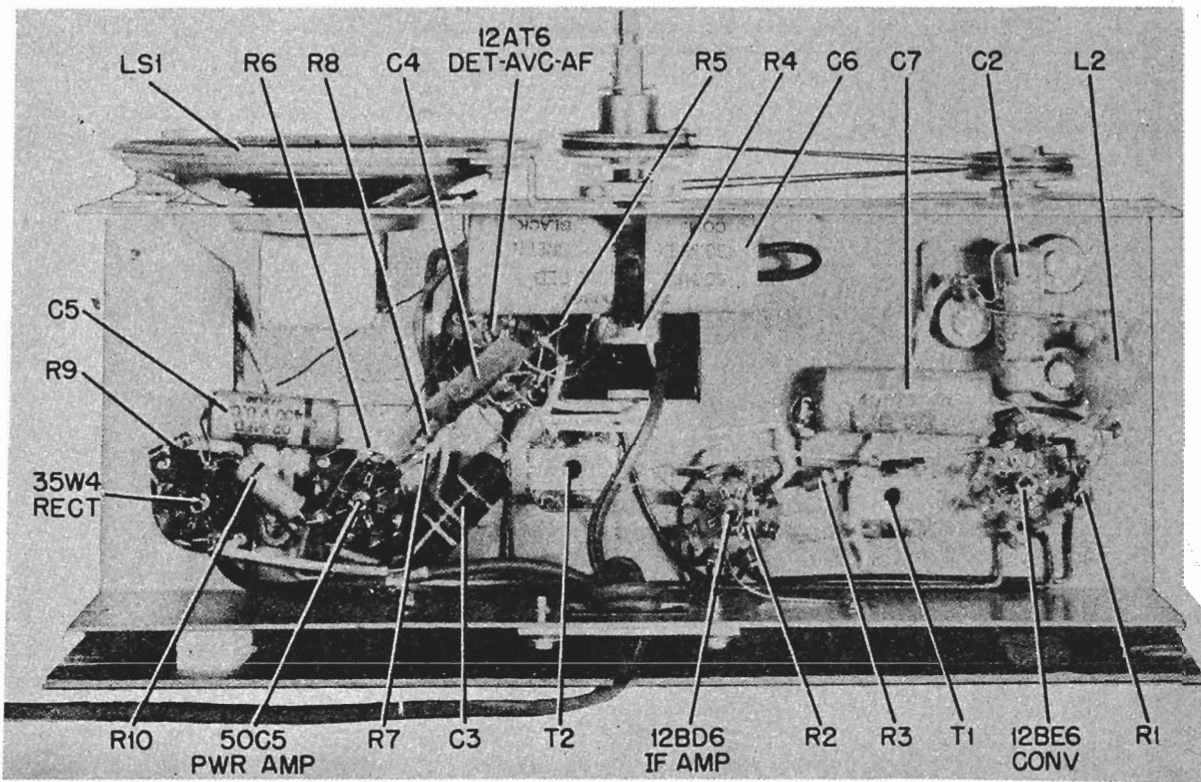
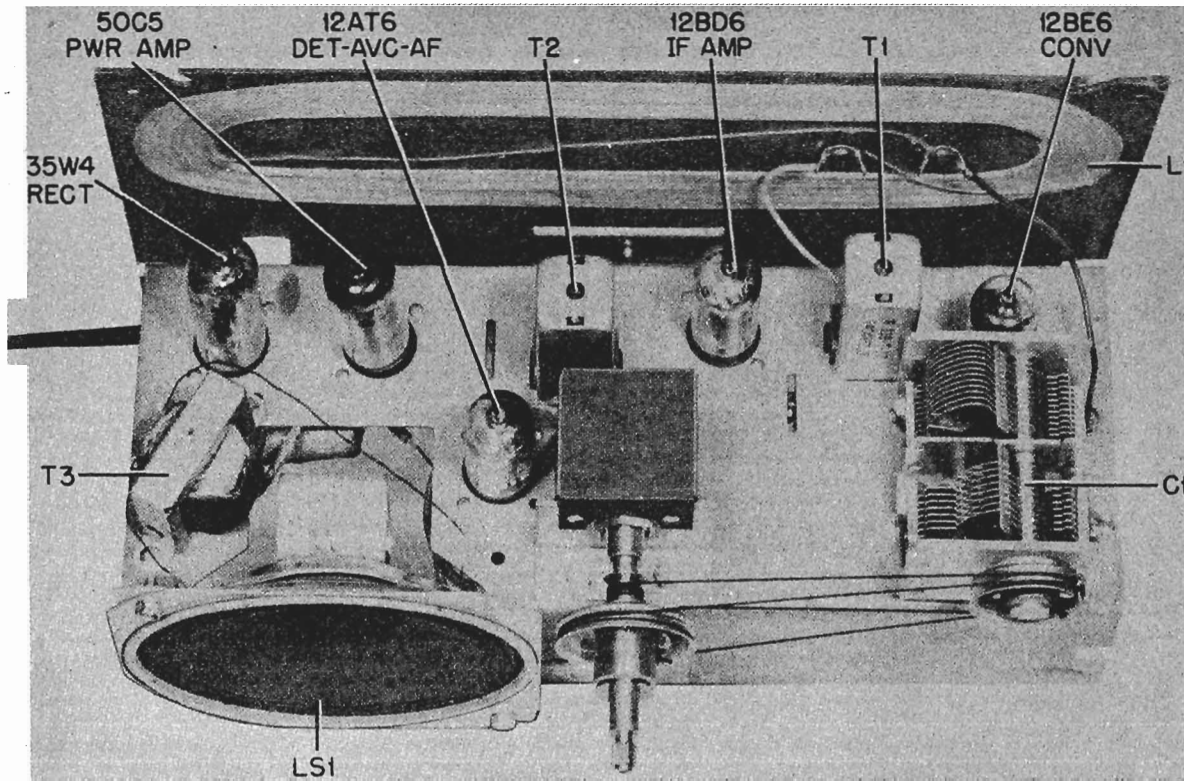

FIGURE 3. PARTS LOCATIONS

MODELS 52H11U, 52H12U,
52H13U, 52H14U, Ch. HS-313

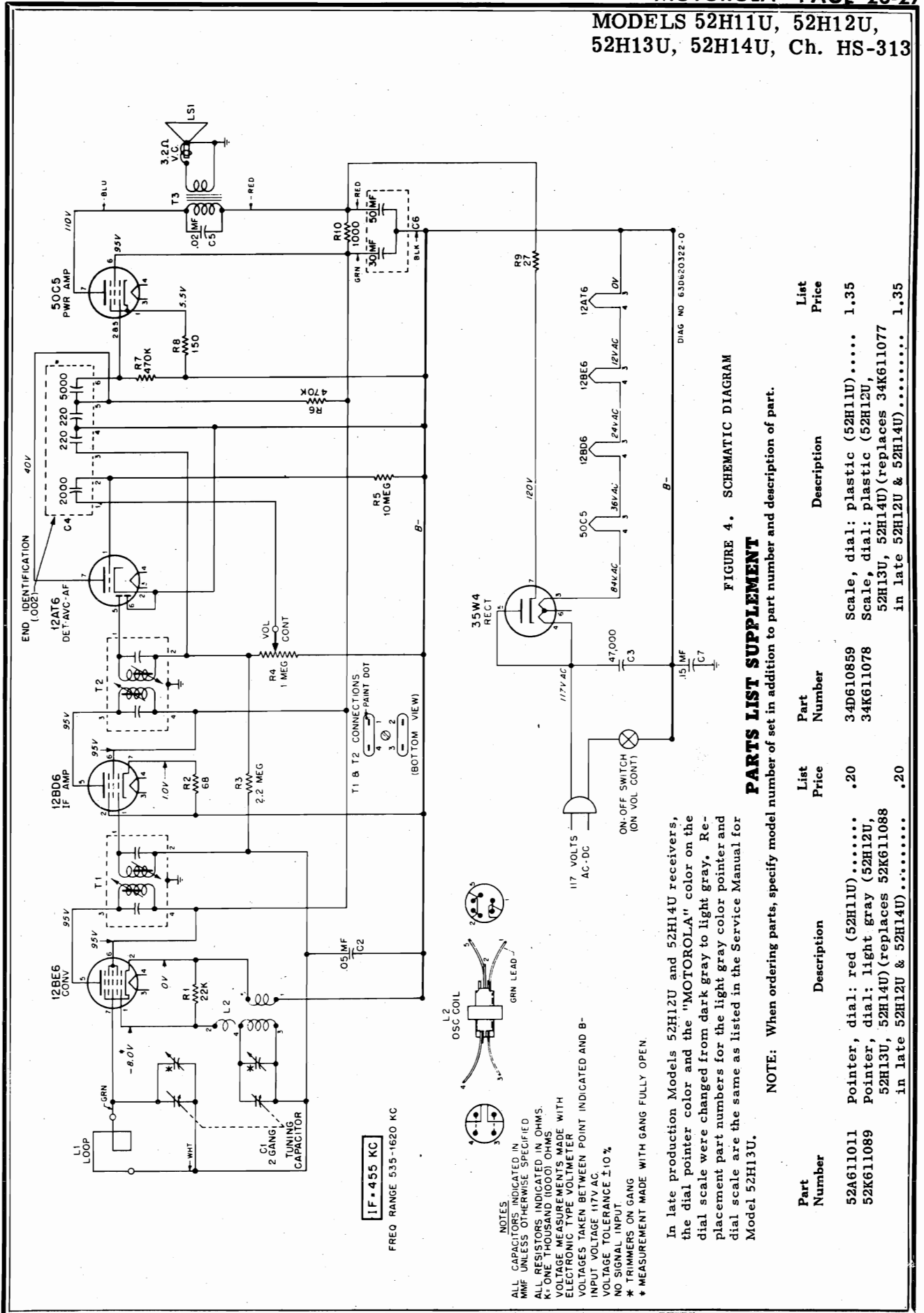

FIGURE 4. SCHEMATIC DIAGRAM

PARTS LIST SUPPLEMENT

NOTE: When ordering parts, specify model number of set in addition to part number and description of part.

Part Number	Description	List Price	Part Number	Description	List Price
52A611011	Pointer, dial: red (52H11U).....	.20	34D610859	Scale, dial: plastic (52H11U).....	1.35
52K611089	Pointer, dial: light gray (52H12U, 52H13U, 52H14U) (replaces 52K611088 in late 52H12U & 52H14U).....	.20	34K611078	Scale, dial: plastic (52H12U, 52H13U, 52H14U) (replaces 34K611077 in late 52H12U & 52H14U).....	1.35

In late production Models 52H12U and 52H14U receivers, the dial pointer color and the "MOTOROLA" color on the dial scale were changed from dark gray to light gray. Replacement part numbers for the light gray color pointer and dial scale are the same as listed in the Service Manual for Model 52H13U.

- NOTES
- ALL CAPACITORS INDICATED IN MMF UNLESS OTHERWISE SPECIFIED
 - ALL RESISTORS INDICATED IN OHMS. K= ONE THOUSAND (1000) OHMS
 - VOLTAGE MEASUREMENTS MADE WITH ELECTRONIC TYPE VOLTMETER
 - VOLTAGES TAKEN BETWEEN POINT INDICATED AND B-
 - INPUT VOLTAGE 117V AC
 - VOLTAGE TOLERANCE $\pm 10\%$
 - NO SIGNAL INPUT
 - * TRIMMERS ON GANG
 - * MEASUREMENT MADE WITH GANG FULLY OPEN.

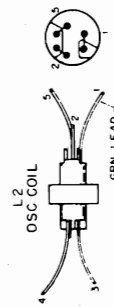

IF-455 KC
FREQ RANGE 535-1620 KC

MODELS 52H11U, 52H12U,
52H13U, 52H14U, Ch. HS-313

PARTS LIST

NOTE: When ordering parts specify model and chassis numbers of set in addition to part number and description of part.

Ref. No.	Part Number	Description	List Price	Part Number	Description	List Price
CHASSIS PARTS - ELECTRICAL						
<u>Capacitors</u>						
C-1	19B610878	Variable, 2-gang: with pulley.....	2.70	30A470651	Cord, line: with plug; 6 ft lg....	.75
C-2	8R9821	Paper: .05 mf 200V.....	.20	5S7805	Eyelet, snap-in (vol control in- sulator mtg).....doz	.15
C-3	8R490232	Molded paper: 47,000 mmf 400V	.25	5A19658	Eyelet, spacer (gang mtg).....doz	.20
C-4	21B482847	Ceramic, multiple: 2000, 220, 220, 5000 mmf.....	.65	5A70404	Grommet, gang mtg: rubber.....	.05
C-5	8R9802	Paper: .02 mf 400V.....	.20	14A482844	Insulator, line cord outlet: fibre.....doz	.25
C-6	23B600855	Electrolytic: 50-30 mf/150V.	1.10	14A611064	Insulator, volume control: fibre (over vol control).....	.10
C-7	8K72686	Paper: .15 mf 200V.....	.25	2S7051	Nut, hex:palnut: 3/8-32 x 9/16 (volume control mtg).....doz	.15
<u>Coils</u>						
L-1	24C610884	Antenna Loop and Panel Assembly.....	1.30*	1X611087	Pulley and Bushing Assembly, pointer drive.....	.20
L-2	24K600812	Oscillator coil.....	.85	47A611028	Shaft, tuning.....	.15
<u>Speaker</u>						
LS-1	50B611018	Speaker: 4" PM; 3.2 ohm VC..	3.90*	9K580218	Socket, tube: miniature; 7-prong; with dummy lug and center shield; wafer type.....	.15
	or 50C611450	exch	2.95	41A471681	Spring, tension (drive cord)....doz	.40
				4A73639	Washer, "C" (tuning shaft re- tainer).....doz	.20
				4A21491	Washer, flat (on tuning shaft)....doz	.15
				4K482859	Washer, insulated shoulder (loop brkt mtg).....doz	.15
<u>Resistors</u>						
Note: All resistors are insulated carbon type unless otherwise specified.						
R-1	6R6028	22,000 20% 1/2W.....doz	1.20	CABINET PARTS		
R-2	6R2039	68 10% 1/2W.....doz	1.20	64A611499	Baffle, speaker: cardboard.....	.05
R-3	6R3927	2.2 meg 20% 1/2W.....doz	1.20	16E610760	Cabinet, table model: plastic; walnut; less speaker grille and dial scale (52H11U).....	4.30*
R-4	18B611017	Volume control: 1 meg; in- cludes on-off switch.....	1.50	16K610761	Cabinet, table model: plastic; ivory; less speaker grille and dial scale (52H12U).....	5.95*
R-5	6R2109	10 meg 20% 1/2W.....doz	1.20	16K610762	Cabinet, table model: plastic; green; less speaker grille and dial scale (52H13U).....	5.95*
R-6	6R6032	470,000 20% 1/2W.....doz	1.20	16K610763	Cabinet, table model: plastic; gray; less speaker grille and dial scale (52H14U).....	5.95*
R-7	6R6032	470,000 20% 1/2W.....doz	1.20	13A610872	Grille, speaker: perforated metal.	.20
R-8	6R6373	150 10% 1/2W.....doz	1.20	36B610880	Knob, tuning: walnut (52H11U)....	.25
R-9	6R5683	27 10% 1/2W.....doz	1.20	36K610881	Knob, tuning: ivory (52H12U)....	.25
R-10	6R6327	1000 10% 1W.....doz	.20	36K610882	Knob, tuning: green (52H13U)....	.25
<u>Transformers</u>						
T-1,2	24C485553	IF and Diode Transformer: 455 Kc; complete with capa- citors, cores and shield... .95		36K610883	Knob, tuning: gray (52H14U)....	.25
T-3	25K485973	Output transformer.....	.80	36B611024	Knob, volume: walnut (52H11U)....	.25
<u>Part Number Description List Price</u>						
CHASSIS PARTS - MECHANICAL						
7K485971	Bracket, loop mtg.....	.05	36K611025	Knob, volume: ivory (52H12U)....	.25	
7A610861	Bracket, speaker mtg (top).....	.10	36K611026	Knob, volume: green (52H13U)....	.25	
7A610865	Bracket, speaker mtg (bottom)....	.10	36K611027	Knob, volume: gray (52H14U)....	.25	
7K610875	Bracket, tuning shaft mtg.....	.05	38A25507	Plug, split (loop panel mtg)....doz	.15	
7K610870	Bracket, volume control mtg.....	.05	52A611011	Pointer, dial: red (52H11U).....	.20	
42A610858	Clip, electrolytic mtg.....	.05	52K611088	Pointer, dial: dark gray (52H12U & 52H14U).....	.20	
42A485548	Clip, IF trans mtg.....doz	.20	52K611089	Pointer, dial: light gray (52H13U)	.20	
			34D610859	Scale, dial: plastic (52H11U)....	1.35	
			34K611077	Scale, dial: plastic (52H12U & 52H14U).....	1.35	
			34K611078	Scale, dial: plastic (52H13U)....	1.35	
			2S7092	Speednut (speaker grille mtg)..doz	.15	

PRICES SUBJECT TO CHANGE WITHOUT NOTICE
*Plus Federal Excise Tax At Current Rate

MODELS 62X11U, 62X12U,
62X13U, Ch. HS-314

GENERAL INFORMATION

TYPE - AC-DC operated table model superheterodyne receiver with loop antenna.

RECEIVER MODELS -	Model	Color
	62X11U	Walnut
	62X12U	Ivory
	62X13U	Green

TUNING RANGE - 535 to 1620 Kc IF - 455 Kc

TUBE COMPLEMENT -	Type	Function
	12BD6	RF Amplifier
	12BE6	Converter
	12BD6	IF Amplifier
	12AT6	Det, AVC & 1st AF Amp
	35C5	Power Amplifier
	35W4	Rectifier

POWER SUPPLY - 117 volts AC or DC, 35 watts

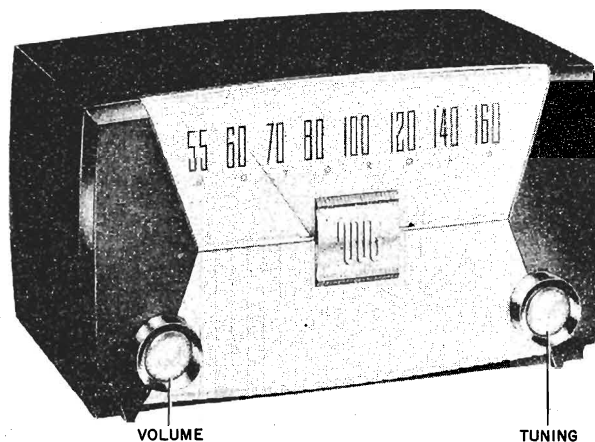

OPERATING INSTRUCTIONS

POWER SWITCH AND VOLUME CONTROL. Operated with left-hand knob. **NOTE:** Reverse the line cord plug in the electrical outlet if the radio does not operate from DC. When operating from AC, reversing the plug in the wall outlet may sometimes improve reception.

TUNING. Tune stations with right-hand knob.

ANTENNA. A built-in loop antenna eliminates the need for an outside antenna in most locations. When receiving a weak station, rotate the receiver slightly for best signal strength. If additional pick-up is necessary, connect an external antenna to the radio by following the instructions printed on the rear panel. **CAUTION:** Never connect the radio chassis to a water pipe, radiator, or other ground.

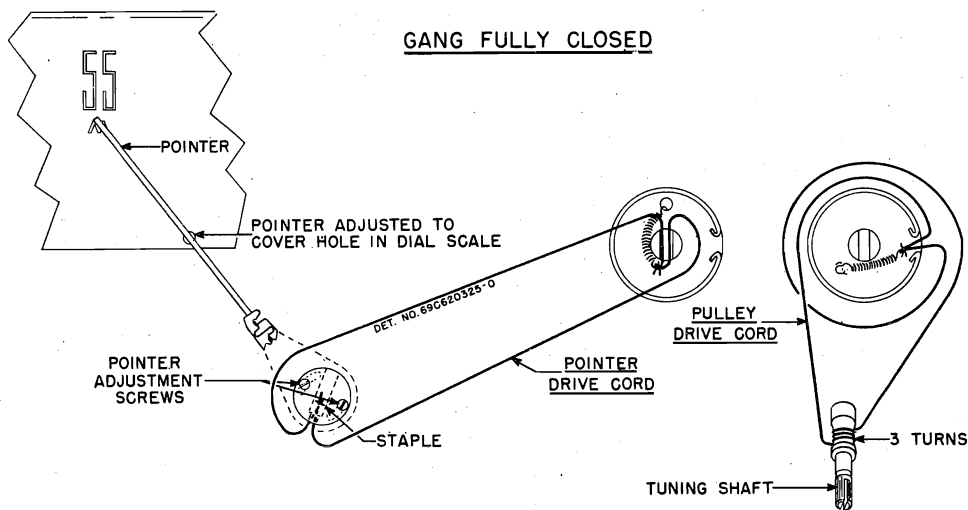

FIGURE 1. DIAL RESTRINGING DETAIL

MODELS 62X11U, 62X12U,
62X13U, Ch. HS-314

SERVICE NOTES

The chassis of this receiver is isolated from the AC power line circuit by a capacitor to eliminate the shock hazard when handling the receiver. However, as an additional precaution when aligning or servicing the receiver from AC, an isolation transformer should be inserted between the power line and the chassis.

- TO REMOVE THE CHASSIS FROM THE CABINET**
1. Pull off the two control knobs.
 2. Remove split plugs which hold the loop to the cabinet.
 3. From the back of the cabinet, remove the two hex head screws at the rear edge of the radio chassis.
 4. Slide the radio chassis and loop from the cabinet.

ALIGNMENT

NOTE: If AC power is used, it is recommended that an isolation transformer be placed between the power line and the receiver to avoid hum and electrical shocks. If an isolation transformer is not available, connect the low side of the signal generator to B- through a .1 mf capacitor.

1. Connect a low range output meter across the speaker voice coil.
2. Connect the low side of the signal generator to B-.
3. Set the signal generator for 400 cycle, 30% modulation.

4. Turn the receiver volume control to maximum.
5. Use a small fibre screwdriver for aligning the IF and diode transformers.
6. As stages are brought into alignment, reduce the signal generator output to a level which produces less than .40 volts (.05 watt) across the voice coil to avoid overloading the receiver.
7. See Figure 2 for adjustment locations and the following chart for procedure.

ALIGNMENT CHART

STEP	DUMMY ANTENNA	GENERATOR CONNECTION	GENERATOR FREQUENCY	GANG SETTING	ADJUST	REMARKS
IF ALIGNMENT						
1.	.1 mf	Rear stator of tuning capacitor	455 Kc	Fully open	1, 2, 3 & 4 (IF cores)	Adjust for maximum.
WAVETRAP						
2.	.1 mf	Rear stator of tuning capacitor	455 Kc	Fully open	5 (Wavetrap)	Adjust for minimum.
RF ALIGNMENT						
3.	.1mf	Rear stator of tuning capacitor	1620 Kc	Fully open	6 (Osc)	Adjust for maximum.
4.	-	Radiation loop*	1400 Kc	Tune for max	7 (Ant)	Adjust for maximum.

*Connect generator output to 5" diameter, 5 turn loop and couple inductively to receiver loop. Keep loops at least 12" apart.

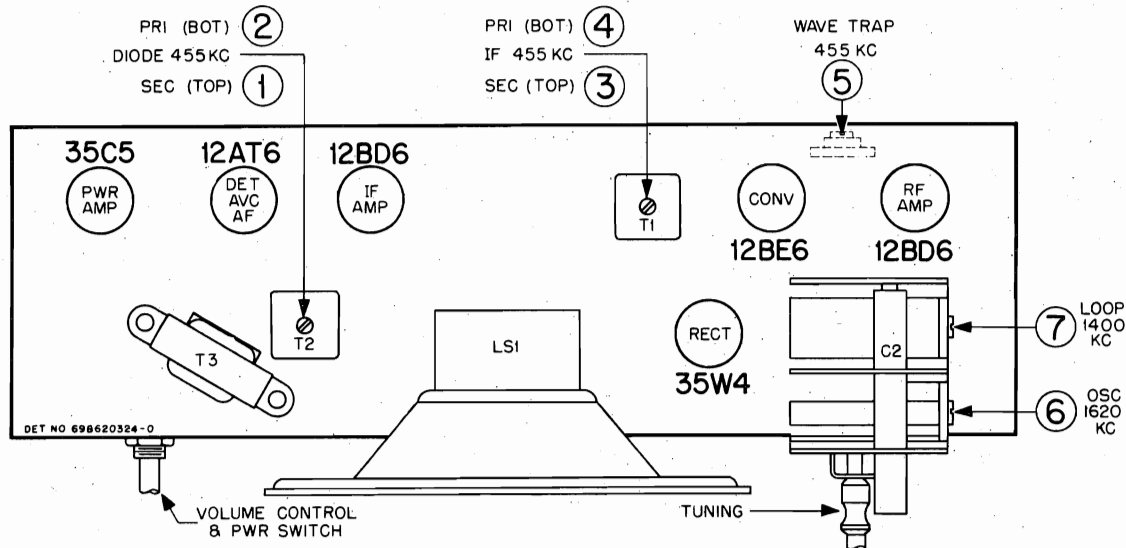

FIGURE 2. TUBE AND TRIMMER LOCATIONS

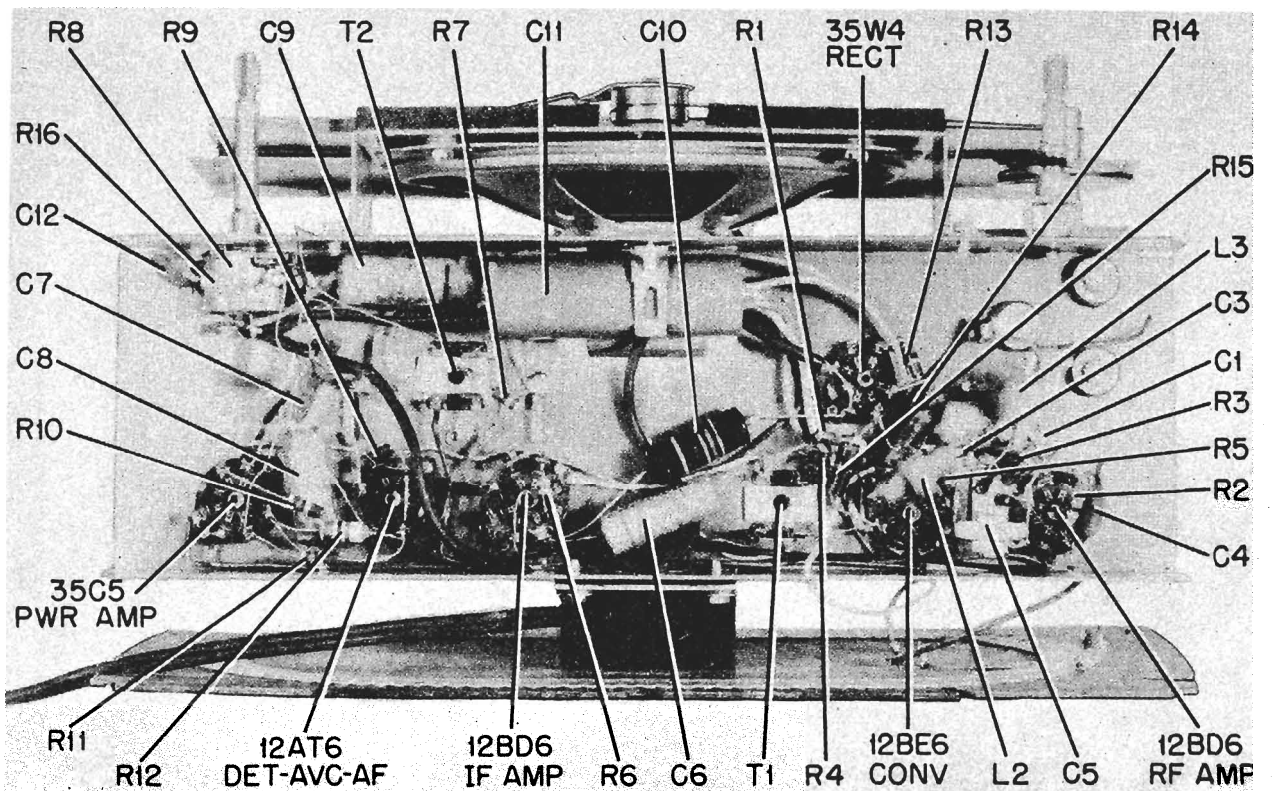
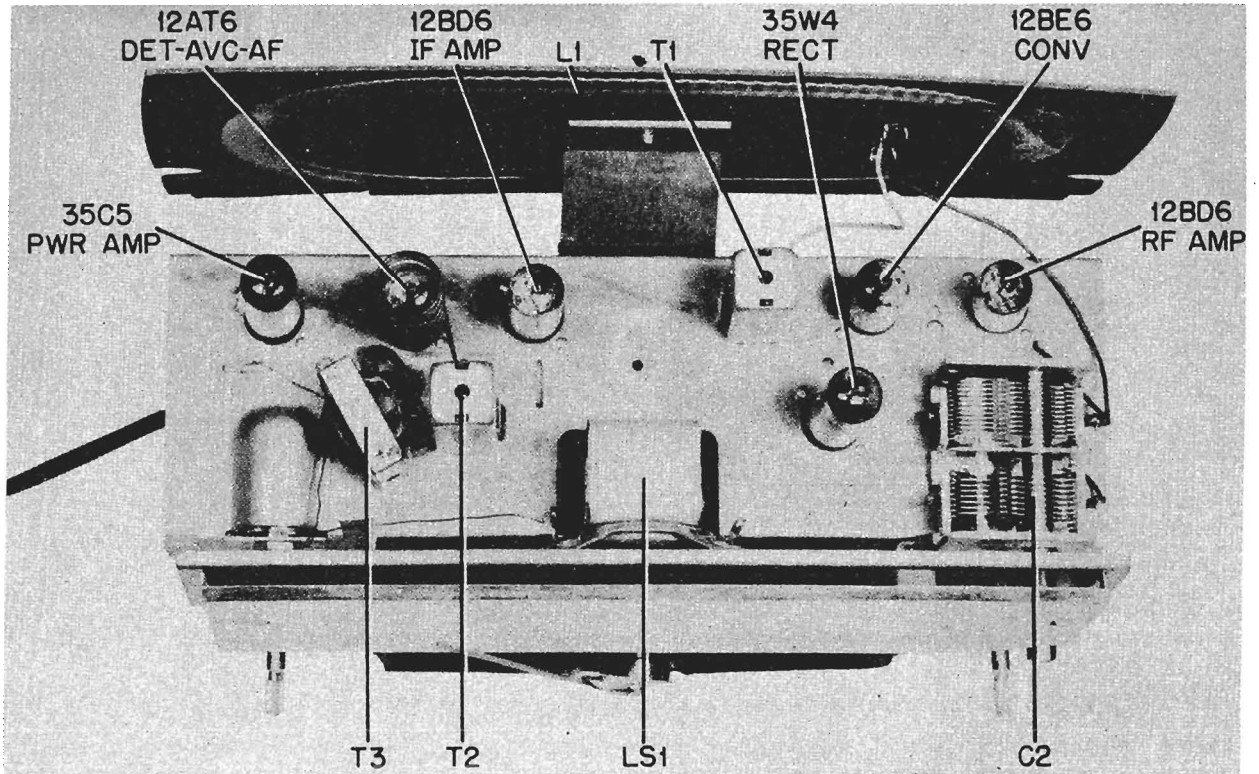
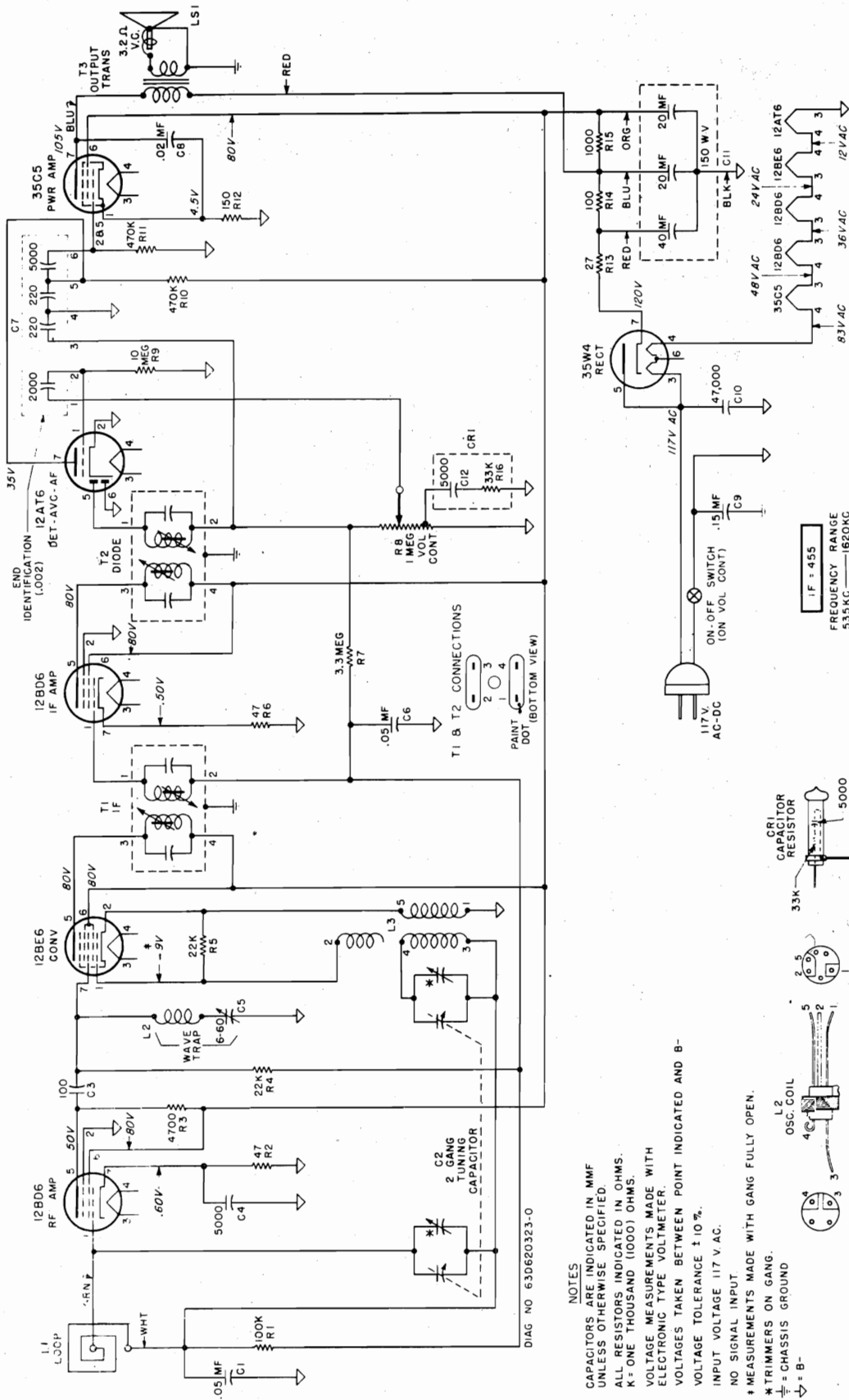

FIGURE 3. PARTS LOCATIONS

PAGE 23-32 MOTOROLA
MODELS 62X11U, 62X12U,
62X13U, Ch. HS-314



NOTES

- CAPACITORS ARE INDICATED IN MMF UNLESS OTHERWISE SPECIFIED.
- ALL RESISTORS INDICATED IN OHMS.
- K = ONE THOUSAND (1000) OHMS.
- VOLTAGE MEASUREMENTS MADE WITH ELECTRONIC TYPE VOLTMETER.
- VOLTAGES TAKEN BETWEEN POINT INDICATED AND B-
- INPUT VOLTAGE 117 V. AC.
- NO SIGNAL INPUT
- * MEASUREMENTS MADE WITH GANG FULLY OPEN.
- * TRIMMERS ON GANG.
- ⊕ = CHASSIS GROUND
- ↘ = B-

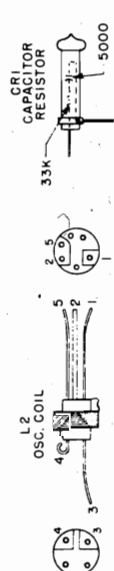

FIGURE 4. SCHEMATIC DIAGRAM

PARTS LIST

NOTE: When ordering parts, specify model and chassis number of set in addition to part number and description of part.

Ref. No.	Part Number	Description	List Price	Part Number	Description	List Price
CHASSIS PARTS - ELECTRICAL				CHASSIS PARTS - MECHANICAL		
<u>Capacitors</u>				45A610890	Arm, pointer support.....	.05
C-1	8R9821	Paper: .05 mf 200V.....	.20	7K600579	Bracket, loop mtg.....	.10
C-2	19B611094	Variable, 2-gang; with pulley	2.80	7A600476	Bracket, tuning shaft.....	.10
C-3	21R6641	Mica: 100 mmf 500V.....	.20	42A610858	Clip, electrolytic mtg.....	.05
C-4	21R115312	Ceramic, disc: 5000 mmf 500V	.25	42B485548	Clip, IF trans mtg.....	.20
C-5	20A26941	Mica, variable: 6 mmf-60 mmf; includes bracket.....	.30	30A470651	Cord, line: with plug; 6 ft lg....	.75
C-6	8R9821	Paper: .05 mf 200V.....	.20	5A19658	Eyelet, spacer (gang mtg).....	.20
C-7	21B482847	Ceramic, multiple: 2000 mmf, 220 mmf, 220 mmf, 5000 mmf.	.65	5A70404	Grommet, gang mtg: rubber.....	.05
C-8	8R9802	Paper: .02 mf 400V.....	.20	14A482844	Insulator, line cord outlet: fibre.....	.25
C-9	8R9843	Paper: .15 mf 200V.....	.20	2S7051	Nut, hex palnut: 3/8-32 x 9/16 (volume control mtg).....	.15
C-10	8R490232	Molded paper: 47,000 mmf 400V	.25	35K611043	Pad, cushion: sponge rubber: 2-5/8" lg x 1/4" wide x 1/4" thick (on spkr mtg plate).....	.05
C-11	23K484234	Electrolytic: 40-20-20 mf/150V	1.40	35K611045	Pad, cushion: sponge rubber; 7-1/4" lg x 1/4" wide x 3/8" thick (on spkr mtg plate).....	.10
C-12	21R115312	Ceramic, disc: 5000 mmf 500V (in some sets).....	.25	1X611179	Plate, speaker mtg: with pointer bearing; less cushion pads.....	.90
<u>Capacitor-Resistor</u>				1X620123	Pointer, dial: with tubing.....	.15
CR-1	21B484227	Capacitor-Resistor: 2 lead; 33,000 ohms, 5000 mmf (in some sets).....	.35	49A611183	Pulley, pointer mtg.....	.25
<u>Coils</u>				34C611032	Scale, dial.....	1.15
L-1	24C611037	Antenna Loop and Panel Assembly.....	1.20*	3S114795	Screw, machine: 3-48 x 5/16" slotted binder head (pointer arm mtg).....	.25
L-2	24A77336	Wavetrap.....	.40	1K611042	Shaft, tuning: with pulley.....	.15
L-3	24K600813	Oscillator coil.....	.80	26A481521	Shield, spring (for 12AT6 tube)	.50
<u>Speaker</u>				41A471681	Spring, tension (pointer drive cord).....	.40
LS-1	50C611019	Speaker: 4" x 6" PM; 3.2 ohm VC.....	4.45* exch 3.35	41A14244	Spring, tension (gang drive cord).....	.55
<u>Resistors</u>				9K580218	Socket, tube: miniature; 7-prong; with dummy lug and center shield; wafer type.....	.15
<u>Note: All resistors are insulated carbon type unless otherwise specified.</u>				4K501364	Washer, "C" (tuning shaft and pointer pulley mtg).....	.15
R-1	6R6075	100,000 20% 1/2W.....	doz 1.20	4K482859	Washer, insulated shoulder (loop brkt mtg).....	.15
R-2	6R5550	47 10% 1/2W.....	doz 1.20	CABINET PARTS		
R-3	6R6039	4700 20% 1/2W.....	doz 1.20	16E610796	Cabinet, table model: plastic; walnut; less speaker grille and dial crystal (62X11U).....	6.80*
R-4	6R6028	22,000 20% 1/2W.....	doz 1.20	16K610797	Cabinet, table model: plastic; ivory; less speaker grille and dial crystal (62X12U).....	8.35*
R-5	6R6028	22,000 20% 1/2W.....	doz 1.20	16K610798	Cabinet, table model: plastic; green; less speaker grille and dial crystal (62X13U).....	8.35*
R-6	6R5550	47 10% 1/2W.....	doz 1.20	61D610814	Crystal, dial.....	1.50
R-7	6R2118	3.3 meg 20% 1/2W.....	doz 1.20	13A611181	Grille, speaker.....	.30
R-8	18K611039	Volume control: 1 meg; in- cludes on-off switch.....	1.50	36B611132	Knob, control: walnut (62X11U)....	.10
R-9	6R2109	10 meg 20% 1/2W.....	doz 1.20	36K611133	Knob, control: ivory (62X12U)....	.15
R-10	6R6032	470,000 20% 1/2W.....	doz 1.20	36K611134	Knob, control: green (62X13U)....	.15
R-11	6R6032	470,000 20% 1/2W.....	doz 1.20	38A25507	Plug, split (loop panel mtg)....	.15
R-12	6R3992	150 20% 1/2W.....	doz 1.20	3S3394	Screw, thread cutting: 8-18 x 1/4 plain hex head; cad pl (dial crystal mtg).....	.15
R-13	6R5683	27 10% 1/2W.....	doz 1.20	2S476112	Speednut (spkr grille mtg)...per/c	.50
R-14	6R488025	100 20% 1W.....	each .20			
R-15	6R3953	1000 20% 1W.....	each .20			
R-16	6R6012	33,000 20% 1/2W (in some sets).....	doz 1.20			
<u>Transformers</u>						
T-1,2	24C485553	IF and Diode Transformer: 455 Kc; complete with capacitors, cores, and shield.....	.95			
T-3	25B482858	Output Transformer.....	.95			

PRICES SUBJECT TO CHANGE WITHOUT NOTICE
*Plus Federal Excise Tax At Current Rate

MODELS 62X11U, 62X12U,
62X13U, Ch. HS-314

S U P P L E M E N T N O . 1

This supplement contains dial restringing information for late Model 62X11U series receivers. Refer to the drawing below for instructions. Note that the pointer drive cord is pre-cut and knotted before it is looped around the gang drive shaft. The cord should be nylon, without a fibre glass core, to allow it to stretch during the stringing process.

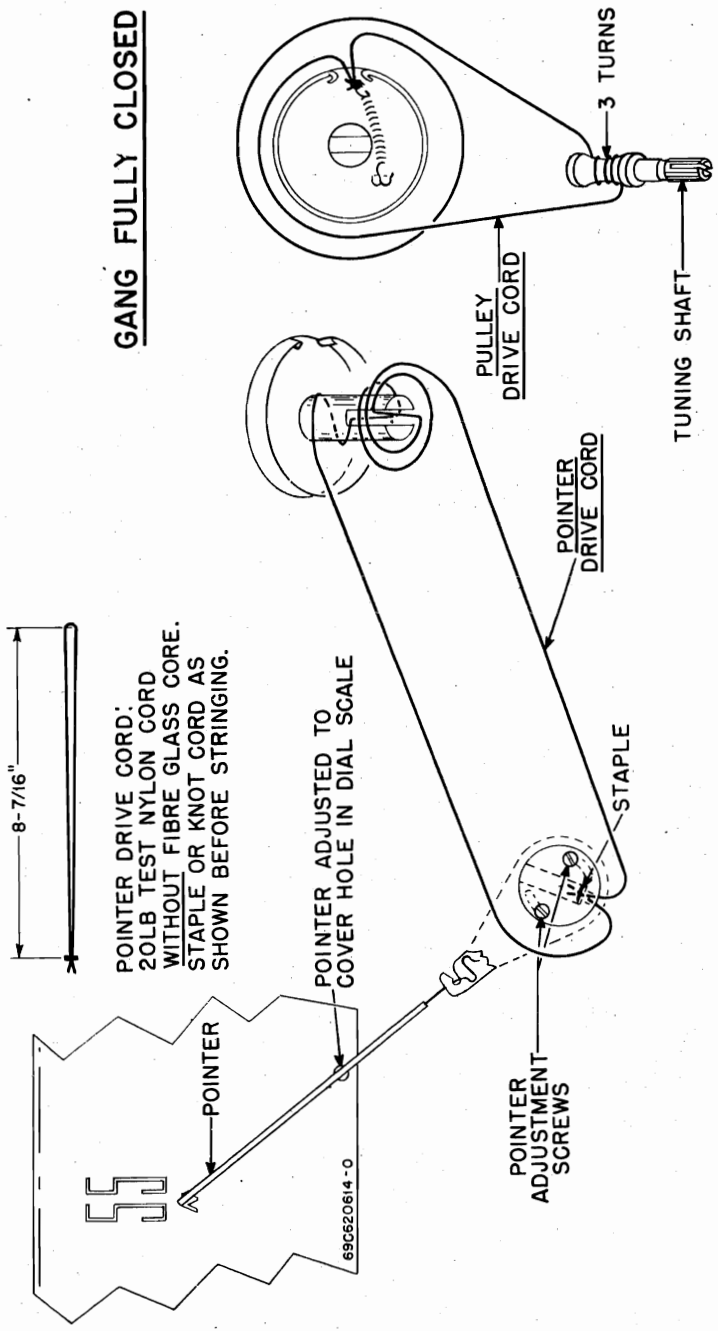

MODELS 52R11, 52R12,
52R13, 52R14, 52R15,
52R16, Ch. HS-289

GENERAL INFORMATION

TYPE - AC-DC table model superheterodyne receiver with "printed" circuit and Ferrite Magnetic Iron Core Antenna.

RECEIVER MODELS -	Model	Color
	52R11	Walnut
	52R12	Ivory
	52R13	Maroon
	52R14	Gray
	52R15	Green
	52R16	Red

TUBE COMPLEMENT -	Type	Function
	12BE6	Converter
	12BD6	IF Amplifier
	12AT6	Det, AVC & AF Amp
	50C5	Power Amplifier
	35W4	Rectifier

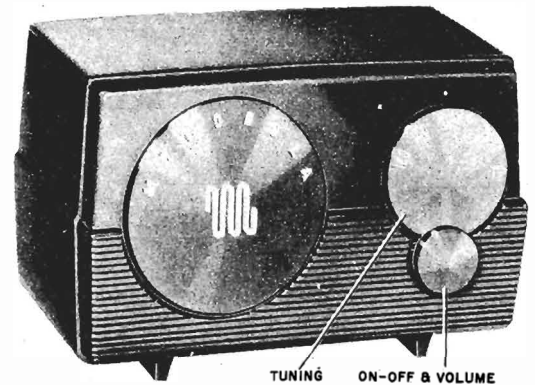

TUNING RANGE - 535 to 1620 Kc IF - 455 Kc

POWER SUPPLY - 117 volts AC or DC; 35 watts

INSTALLATION & OPERATING INSTRUCTIONS

POWER SWITCH & VOLUME CONTROL. Operated with the small lower knob. NOTE: Reverse the line cord plug in the wall outlet if radio does not operate from DC. When operating from AC, reversing the line cord plug in the wall outlet may sometimes improve reception.

TUNING. Stations are tuned in with the large upper knob.

ANTENNA. A built-in Ferrite Magnetic Iron Core Antenna eliminates the need for an outside antenna. When receiving a weak station, rotate the receiver slightly for best signal strength.

CAUTION: Never connect the radio chassis to a water pipe, radiator, or other ground.

SERVICE NOTES

TO REMOVE CHASSIS FROM CABINET:

1. Remove the four screws which hold the back cover, and remove the cover and line cord.
2. Pull off the two control knobs from the front of the receiver.
3. Remove the Phillips head screw under the tuning knob, on the front of the receiver.
4. From the back, remove the screw which holds the line cord plug.
5. Disconnect the leads from the speaker.
6. From the back, remove the three screws which mount the chassis. CAUTION: Do not lose the insulating washers on the screws -they prevent damage to the printed circuit

by the heads of the screws. See Figure 1.

7. Slide the chassis from the cabinet.

CIRCUIT DESCRIPTION

1. The circuit of this chassis is conventional - there are no built-in resistors or capacitors. Leads are printed on both sides of the chassis base, thereby replacing the usual connecting wires and making wiring more uniform.
2. The metal printing extends through all the holes on the chassis, connecting circuits on the front with those on the rear.
3. Reference to the schematic diagram and to Figures 3 and 4 will permit the circuit to be traced easily. Figures 3 and 4 show the front and rear of the chassis, wired and unwired.

**MODELS 52R11, 52R12,
52R13, 52R14, 52R15,
52R16, Ch. HS-289**

SAFETY PRECAUTIONS

1. The chassis of this receiver is connected directly to the power line. However, the power cord circuit is broken by an interlock when the cabinet back is removed for replacing tubes. When aligning or servicing the chassis from AC, an isolation transformer should be inserted between the power line and the chassis.
2. Do not service the chassis on a metal plate, because of the possibility of a short circuit.
3. Use caution when handling the chassis with power applied, because all high voltage leads are exposed.
4. The outer edges of the chassis and the large printed areas in the center are at ground potential.

COMPONENT REPLACEMENT

1. To prevent tube breakage, remove them before replacing components. **CAUTION: Remove the tubes only by pulling them straight out. Wiggling a tube may bend a socket clip, causing poor contact with the tube pin.**
2. **WHEN REMOVING DEFECTIVE COMPONENTS USE ONLY A SMALL SOLDERING IRON (60 WATTS OR LESS) TO AVOID DAMAGE TO THE WIRING. DO NOT USE A SOLDERING GUN. WARNING: THE LEADS ARE VERY THIN, AND EXCESSIVE HEAT WILL BURN THEM OR LOOSEN THEM FROM THE BASE MATERIAL.**
3. Printed connections or leads, if damaged, may be replaced with a jumper of regular hookup wire.
4. It is recommended that IF transformers, the volume control, or the electrolytic capacitor be removed by immersing all the lugs simultaneously into a small soldering pot. The component may then be lifted off the chassis easily. If a soldering pot is not available, heat each lug individually with a small soldering iron, and shake off as much molten solder as possible. Then, by alternately heat-

- ing and loosening each lug, the entire component will be freed. The disadvantage of using a soldering iron instead of a soldering pot is that the printed connections may be pulled loose from the chassis.
5. An individual tube clip may be removed by squeezing it with a pliers and then unsoldering it. The new clip snaps into the hole.
6. Resistors or capacitors may be removed by unsoldering one end at a time.

CAUTION: Clean all the solder from the holes before installing a new component. Do not let the solder run onto an adjacent lead, as a short circuit will be created.

7. Be careful, when removing or replacing the volume control mounting nut or gang mounting screws, that the printing around the holes is not damaged.
 8. When the chassis is fastened into place in the cabinet, be sure the insulating washers are on the mounting screws, otherwise the heads of the screws may damage the printing.
- ANTENNA**

1. A Ferrite Magnetic Iron Core Antenna replaces the conventional "pancake" loop in this receiver. This newer loop is more compact and efficient than the previous type. Its inductance has been pre-set at the factory and requires no adjustment in the field.
2. Under certain circumstances, in early models, AC hum was induced into the loop antenna. This condition was corrected in later models by repositioning the loop. Figure 3 shows the revised location.
3. The service man may convert early models, if necessary, by replacing the loop mounting insulator with the later type, shown in Replacement Parts List. The loop coil itself remains the same.

ALIGNMENT

NOTE: If AC power is used, insert an isolation transformer between the power line and the receiver to avoid hum and electrical shocks. If an isolation transformer is not available, connect the low side of the signal generator to ground (the outer edges of the chassis) through a .1 mf capacitor.

1. Connect a low range output meter across the speaker voice coil.
2. Connect the low side of the signal generator to ground.
3. Set the signal generator for 400 cycle, 30% modulation.

4. Turn the receiver volume control to maximum.
5. Use a small fibre screwdriver for aligning the IF and diode transformers (a "K-Tran" alignment tool is recommended).
6. As stages are brought into alignment, reduce the signal generator output to a level which produces less than .40 volts (.05 watt) across the voice coil to avoid overloading the receiver.
7. See Figure 2 for adjustment locations and the following chart for procedure.

ALIGNMENT CHART

STEP	DUMMY ANTENNA	GENERATOR CONNECTION	GENERATOR FREQUENCY	GANG SETTING	ADJUST	REMARKS
IF ALIGNMENT						
1.	.1 mf	Grid of conv. (pin 7, 12BE6)	455 Kc	Fully open	1, 2, 3 & 4 (IF cores)	Adjust for maximum.
RF ALIGNMENT						
2.	.1 mf	Grid of conv. (pin 7, 12BE6)	1620 Kc	Fully open	5 (Osc)	Adjust for maximum.
3.	-	Radiation loop*	1400 Kc	Tune for max	6 (Ant)	Adjust for maximum.

*Connect generator output across 5" diameter, 5 turn loop and couple inductively to receiver loop. Keep loops at least 12" apart.

MODELS 52R11, 52R12,
52R13, 52R14, 52R15,
52R16, Ch. HS-289

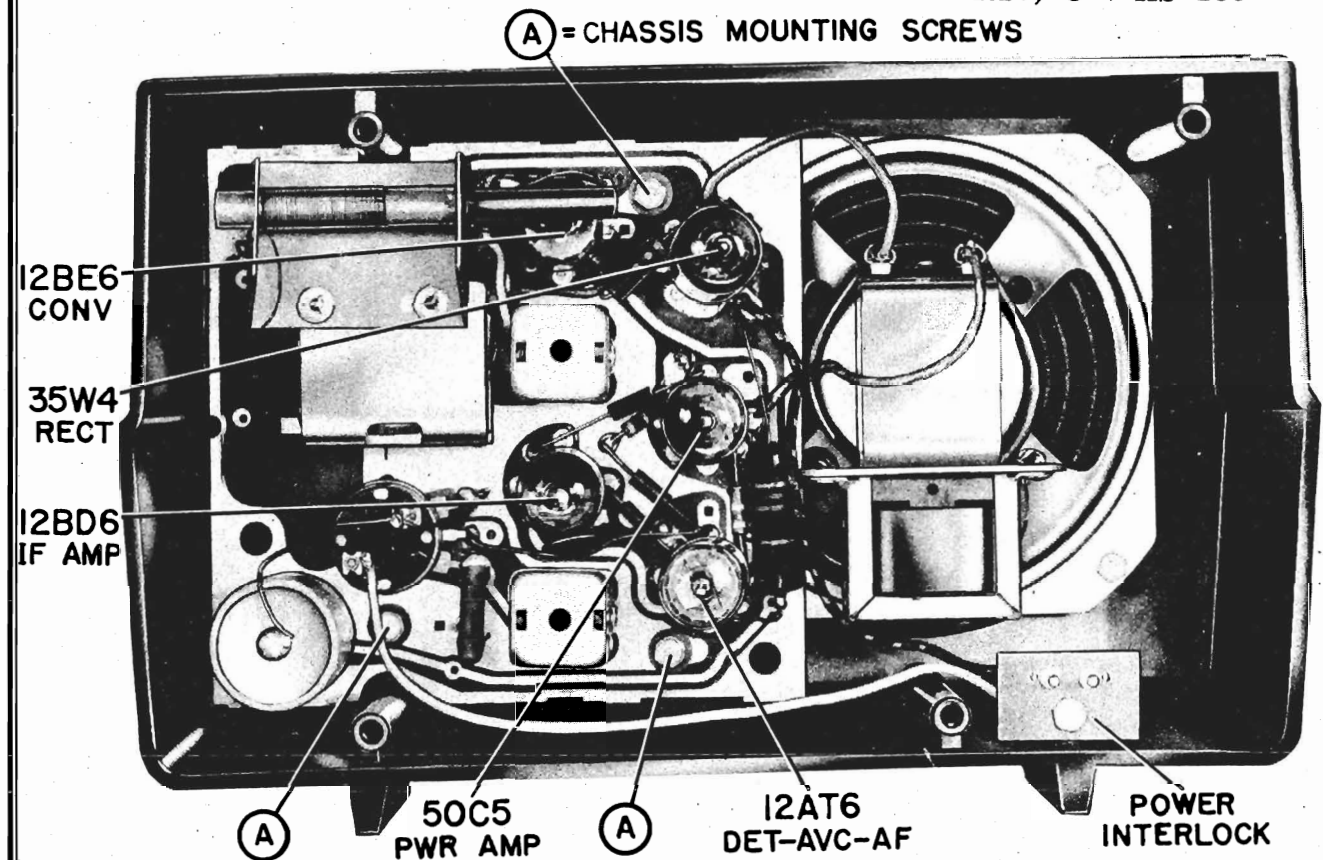
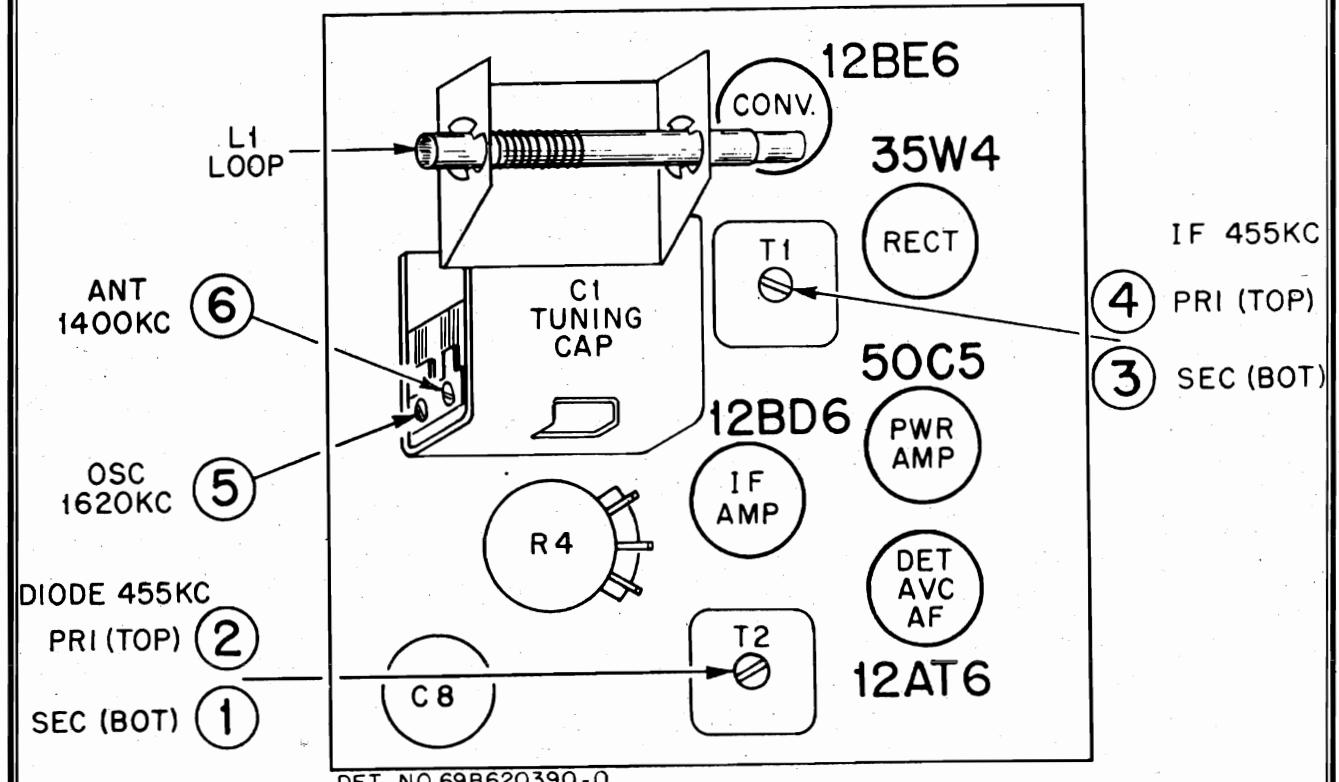

FIGURE 1. REAR VIEW OF RECEIVER (LATE MODEL)



DET. NO.69B620390-0

FIGURE 2. TUBE AND TRIMMER LOCATIONS (LATE MODEL)

MODELS 52R11, 52R12,
52R13, 52R14, 52R15,
52R16, Ch. HS-289

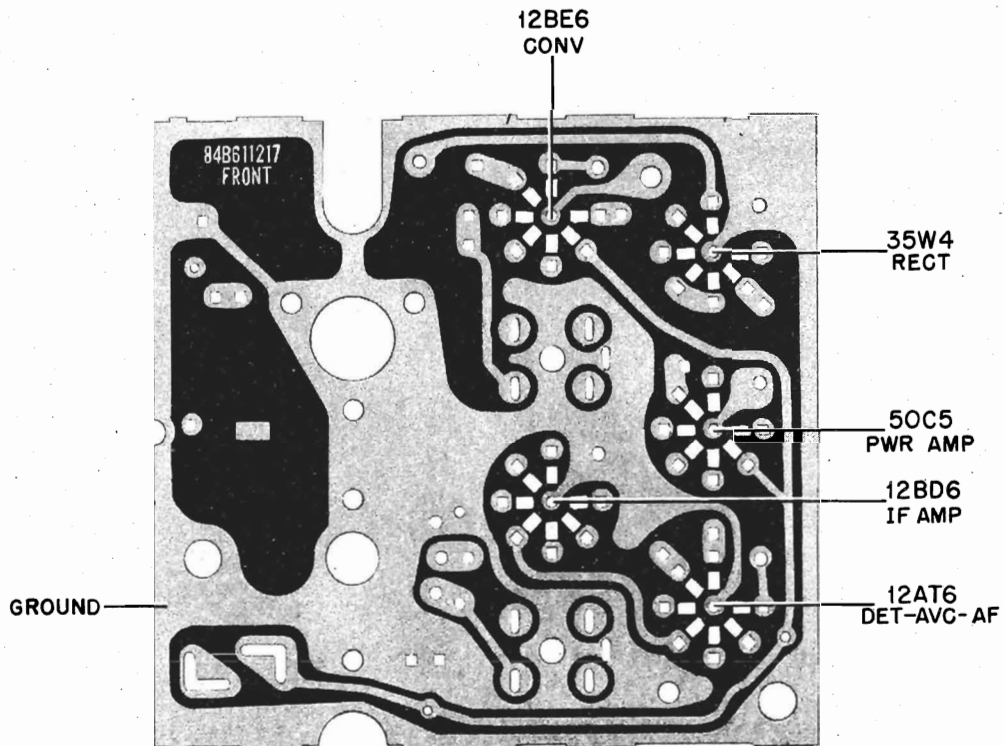
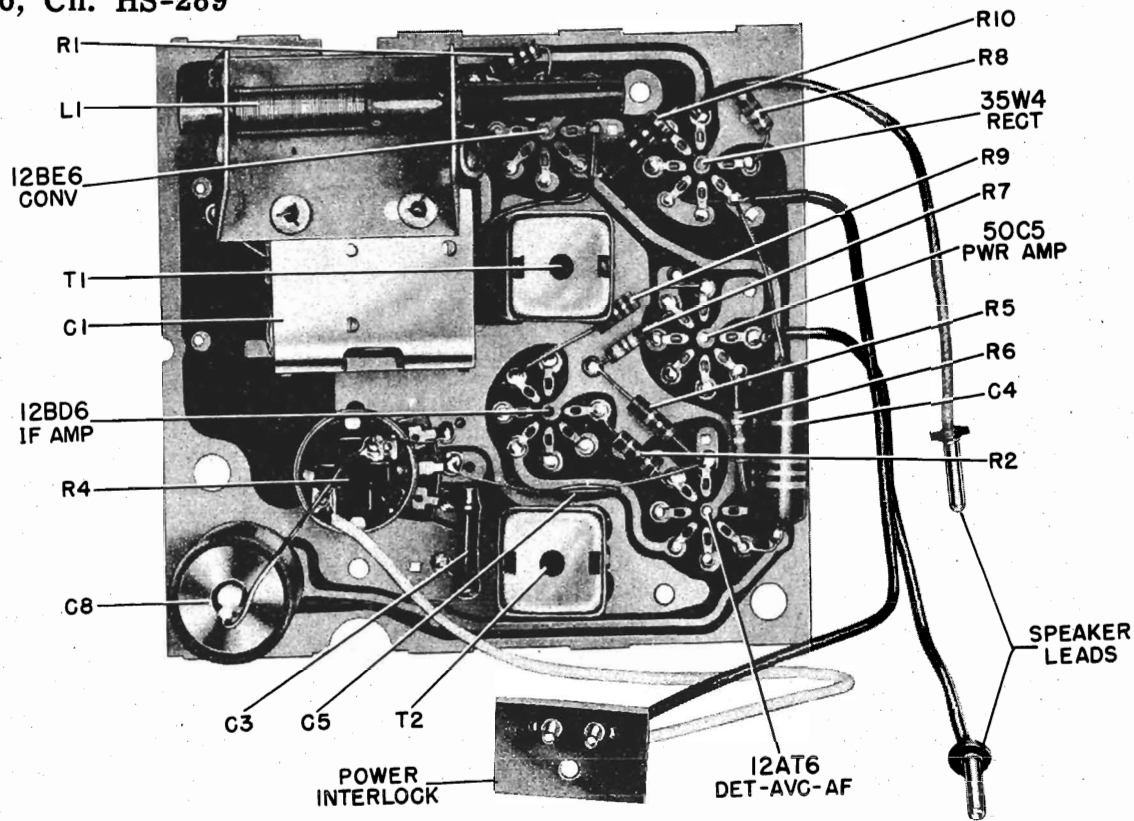

FIGURE 3. FRONT VIEW OF CHASSIS - WIRED AND BLANK (LATE MODEL)

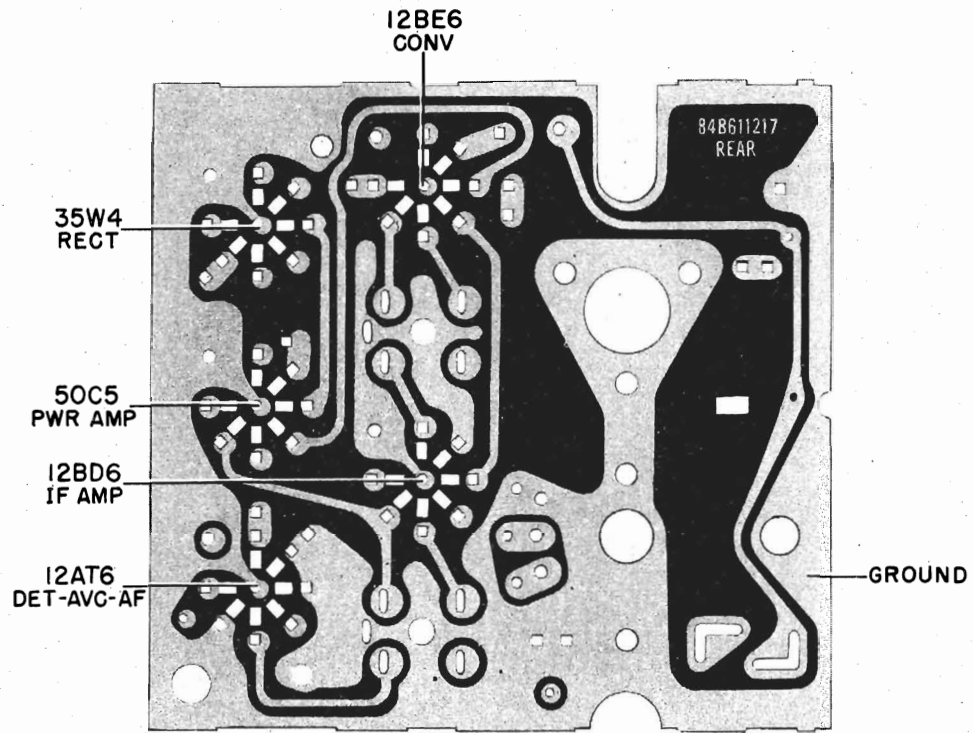
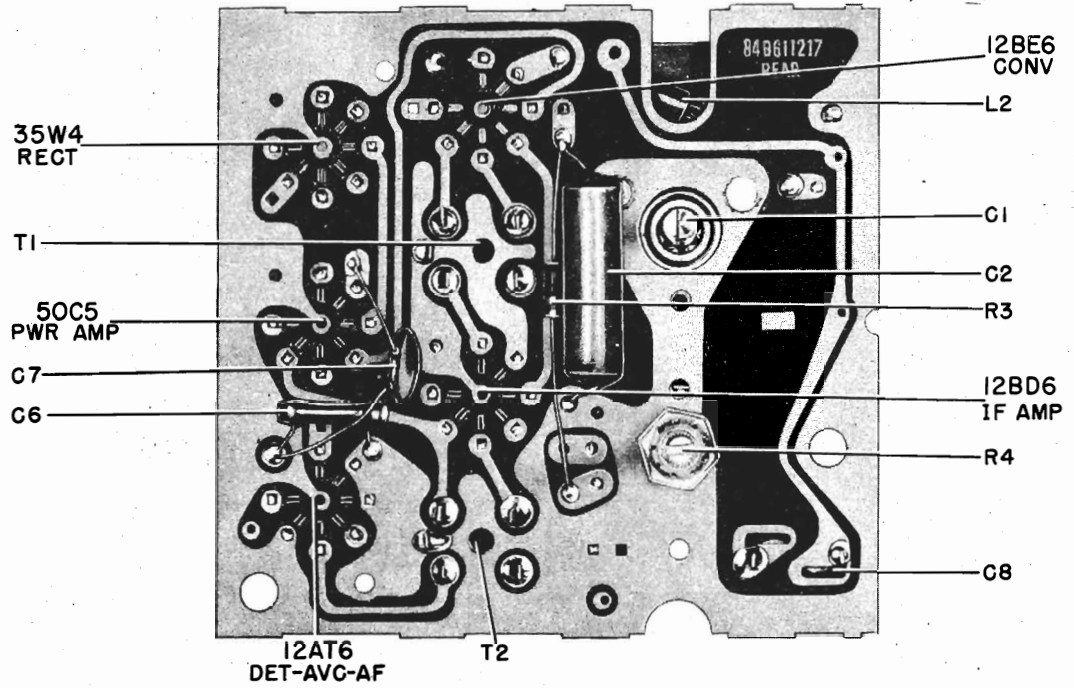

FIGURE 4. REAR VIEW OF CHASSIS - WIRED AND BLANK (LATE MODEL)

MODELS 52R11, 52R12,
52R13, 52R14, 52R15, 52R16, Ch. HS-289

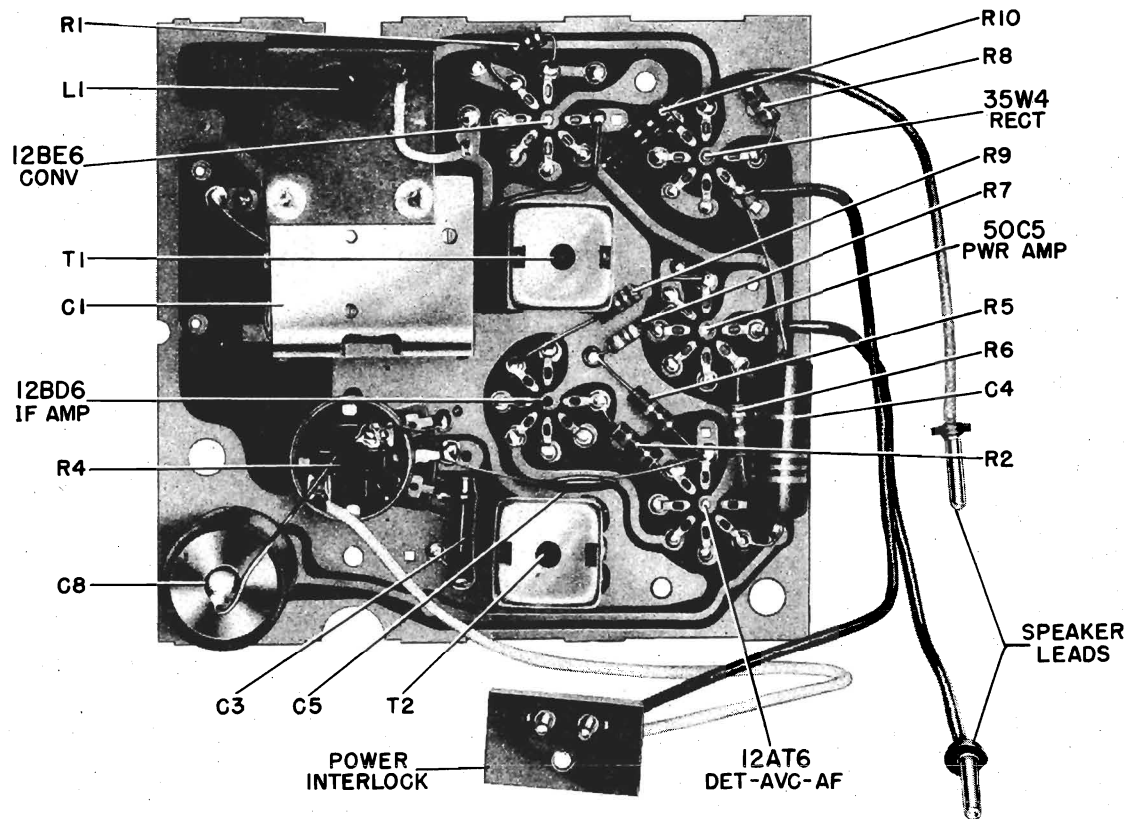

FIGURE 5. FRONT VIEW OF CHASSIS (EARLY MODEL)

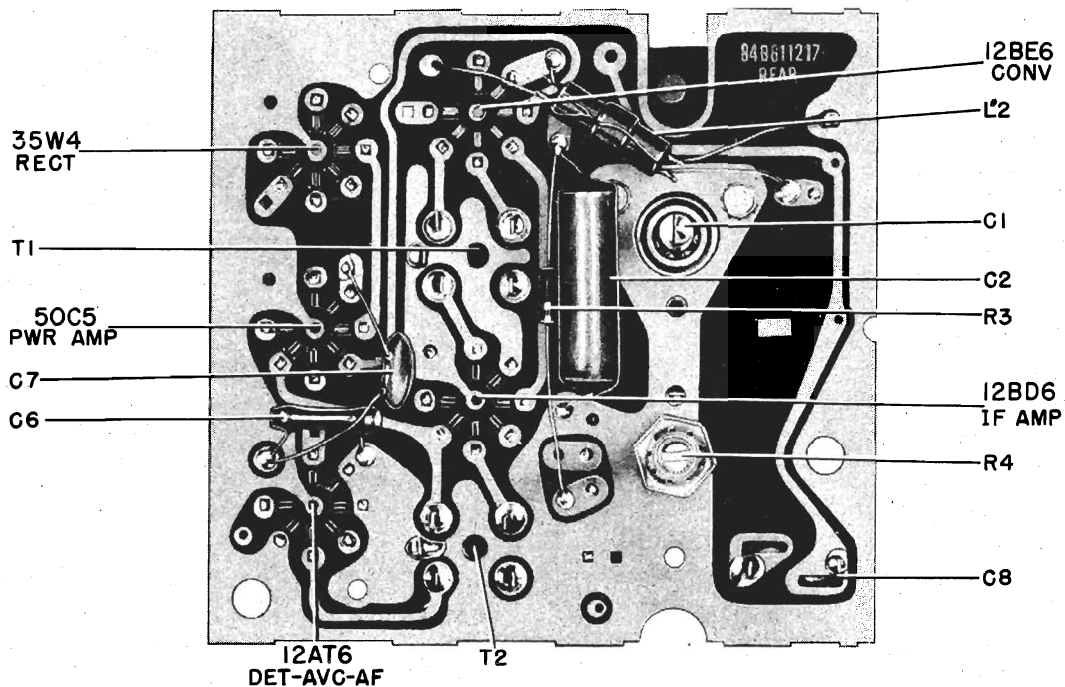
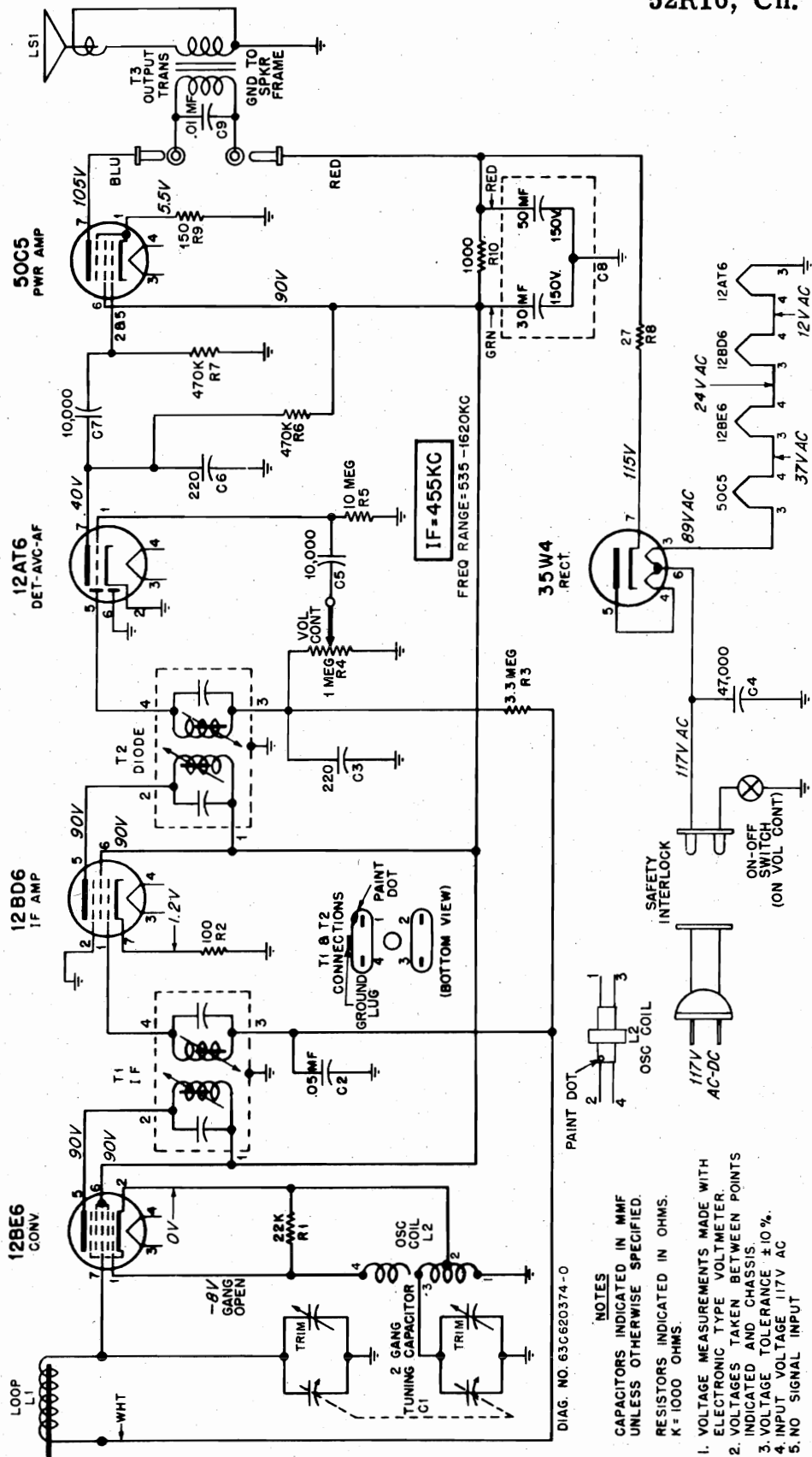

FIGURE 6. REAR VIEW OF CHASSIS (EARLY MODEL)



DIAG. NO. 63C620374-C

NOTES

- 1. VOLTAGE MEASUREMENTS MADE WITH ELECTRONIC TYPE VOLTMETER
- 2. VOLTAGES TAKEN BETWEEN POINTS INDICATED AND CHASSIS.
- 3. VOLTAGE TOLERANCE ±10%.
- 4. INPUT VOLTAGE 117V AC
- 5. NO SIGNAL INPUT

FIGURE 7. SCHEMATIC DIAGRAM

MODELS 52R11, 52R12,
52R13, 52R14, 52R15,
52R16, Ch. HS-289

PARTS LIST

NOTE: When ordering parts, specify model and chassis numbers of set in addition to part number and description of part.

Ref. No.	Part Number	Description	List Price	Part Number	Description	List Price
CHASSIS PARTS - ELECTRICAL						
<u>Capacitors</u>						
C-1	19B610626	Variable: 2-gang.....	2.75	28A610679	Nut, hex: Palnut; 3/8-32 x 9/16 (volume control mtg).....doz	.15
C-2	8R9821	Paper: .05 mf 200V.....	.20	46B480108	Plug, line cord (interlock).....	.15
C-3	21R115905	Ceramic: 220 mmf 500V.....	.25	29A620057	Stud, trimount (ant insulator mtg).....doz	.15
C-4	8R490232	Molded paper: 47,000 mmf 400V	.30		Terminal, pin (on spkr leads)..doz	.20
C-5	21R482726	Ceramic disc: 10,000 mmf 450V	.30			
C-6	21R115905	Ceramic: 220 mmf 500V.....	.25			
C-7	21R482726	Ceramic disc: 10,000 mmf 450V	.30			
C-8	23B610627	Electrolytic: 50-30 mf/150V.	1.35			
C-9	8R9801	Paper: .01 mf 100V.....	.20			
<u>Coils</u>						
L-1	24A610646	Antenna Loop: with core.....	.50*	16C611255	Cabinet, table model: walnut (52R11).....	3.60*
L-2	24A620875	Oscillator coil.....	.90	16K611256	Cabinet, table model: ivory (52R12).....	4.80*
<u>Speaker</u>						
LS-1	50K620141	Speaker: 4" PM; 3.2 ohm VC; includes T-3 and C-9.....	4.95*	16K611258	Cabinet, table model: maroon (52R13).....	4.80*
or	50K620142			16K611259	Cabinet, table model: gray (52R14).....	4.80*
		exch	3.70	16K611260	Cabinet, table model: green (52R15).....	4.80*
				16K611261	Cabinet, table model: red (52R16).	4.80*
<u>Resistors</u>						
Note: All resistors are insulated carbon type unless otherwise specified.						
R-1	6R6028	22,000 20% 1/2W.....doz	1.20	30K610638	Cord, line: with plug & receptacle	.95
R-2	6R6018	100 20% 1/2W.....doz	1.20	1X610655	Cover, cabinet back: with line cord	1.40
R-3	6R2118	3.3 meg 20% 1/2W.....doz	1.20	15K620103	Cover, speaker: walnut (52R11)....	.70
R-4	18A610857	Volume control: 1 meg; with switch.....	1.00	15K620104	Cover, speaker: ivory (52R12)....	.70
R-5	6R2109	10 meg 20% 1/2W.....doz	1.20	15K620105	Cover, speaker: maroon (52R13)....	.70
R-6	6R6032	470,000 20% 1/2W.....doz	1.20	15K620106	Cover, speaker: gray (52R14).....	.70
R-7	6R6032	470,000 20% 1/2W.....doz	1.20	15K620107	Cover, speaker: green (52R15).....	.70
R-8	6R5683	27 10% 1/2W.....doz	1.20	15K620108	Cover, speaker: red (52R16).....	.70
R-9	6R3992	150 20% 1/2W.....doz	1.20	36K611308	Knob, tuning: black (52R11, 52R13, 52R14, 52R15, 52R16).....	.40
R-10	6R3953	1000 20% 1W.....	.20	36K620090	Knob, tuning: ivory (52R12).....	.40
				36K620156	Knob, volume control: black (52R11, 52R13, 52R14, 52R15, 52R16).....	.10
				36K610642	Knob, volume control: ivory (52R12)	.10
				3S115138	Screw, machine: 6-32 x 1-9/16 Phillips flat head; cad pl (chassis mtg - through front of cabinet).....doz	.20
<u>Transformers</u>						
T-1,2	24K610639	IF and Diode Transformer: 455 Kc; complete.....	1.35	3S115237	Screw, thread cutting: 6-20 x 5/16 pl hex head; cad pl (spkr mtg)doz	.40
T-3	25K610631	Output Transformer.....	1.05	3S488009	Screw, thread cutting: 6-20 x 3/8 pl hex head; cad pl (power plug mtg).....doz	.15
<u>Part Number Description List Price</u>						
CHASSIS PARTS - MECHANICAL						
42A610632	Clip, tube pin.....per/c	.50		3S115240	Screw, thread cutting: 6-20 x 1/2 pl hex head; cad pl (chassis mtg & back cover mtg).....	.05
1X620210	Insulator, antenna loop: fibre; with lug (replaces 51A610757 insulator shown in Fig. 5).....	.20	2S400014	Speednut (spkr cover mtg).....	.05	
			4K611121	Washer, flat: paper (chassis mtg screws).....per/c	.50	

PRICES SUBJECT TO CHANGE WITHOUT NOTICE
*Plus Federal Excise Tax At Current Rate

S U P P L E M E N T N O . 1

GENERAL INFORMATION

Chassis HS-289A is the same as HS-289 except for the locations of electrical components (see Figures 1 and 2). For information on Operating Instructions, Service Notes and Alignment refer to HS-289 Service Data.

A dual 250 mmfd ceramic capacitor replaces capacitors C-3 and C-6 used in chassis HS-289. All other chassis parts and cabinet parts remain the same as listed in the HS-289 Service Data.

PARTS LIST SUPPLEMENT

NOTE: When ordering parts, specify model and chassis number of set in addition to part number and description of part. The following parts are revisions of or additions to the original items listed in the HS-289 Service Data.

Ref. No.	Part Number	Description	List Price
C-3,6	21B484337	Ceramic: dual 250 mmfd/450V (Replaces C-3, C-6 21R115905)30

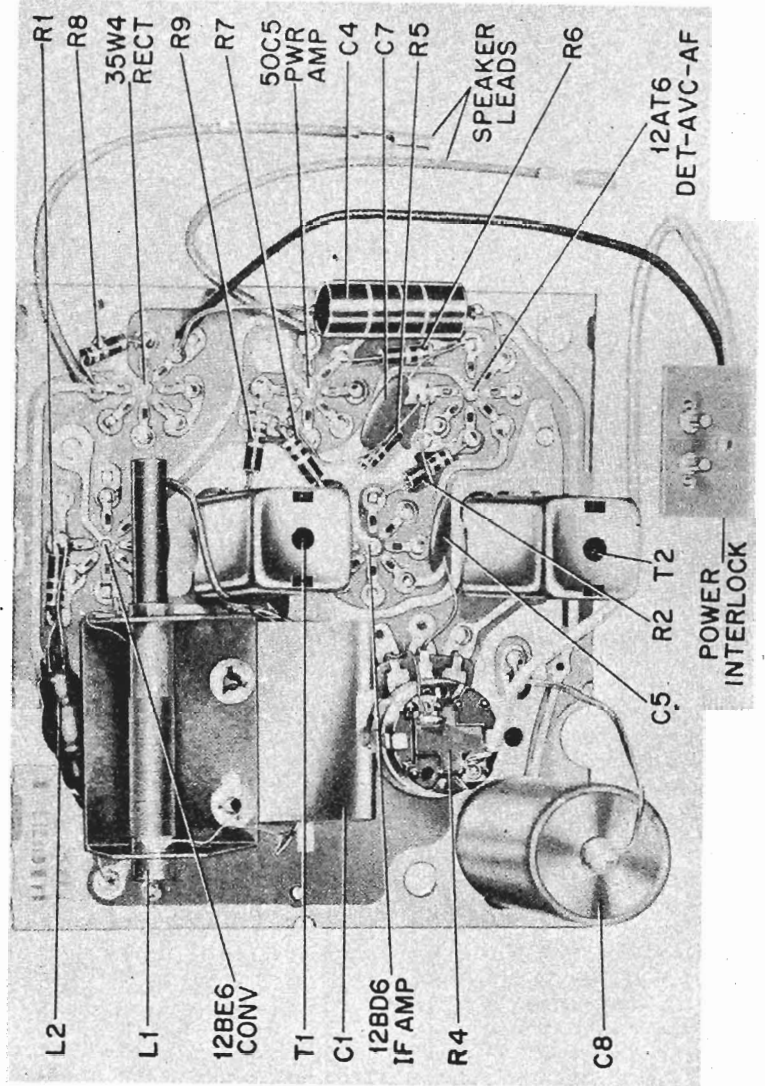

FIGURE 1.

MODELS 52B1U, 52B2U,
52B3U, 52B4U, Ch. HS-305

GENERAL INFORMATION

TYPE - Three-power (AC/DC, Battery) portable radio receiver. Four miniature-type tubes and a selenium rectifier are used in a superheterodyne circuit.

TUNING RANGE - 535 to 1620 Kc **IF** - 455 Kc

POWER SUPPLY - Operates from 117V AC/DC. (15 watts) or from the following batteries:

Two 1-1/2V size "D" flashlight cells

Use: Eveready 950
or Burgess 2
or equivalent.

One 67-1/2V "B" battery

Use: Eveready 457
or Burgess K45
or equivalent.

TUBE COMPLEMENT - Type	Function
1R5	Converter
1U4	IF Amplifier
1U5	Det, AVC & 1st AF Amp
3S4	Power Amplifier
Rectifier	Selenium type -for AC/DC operation

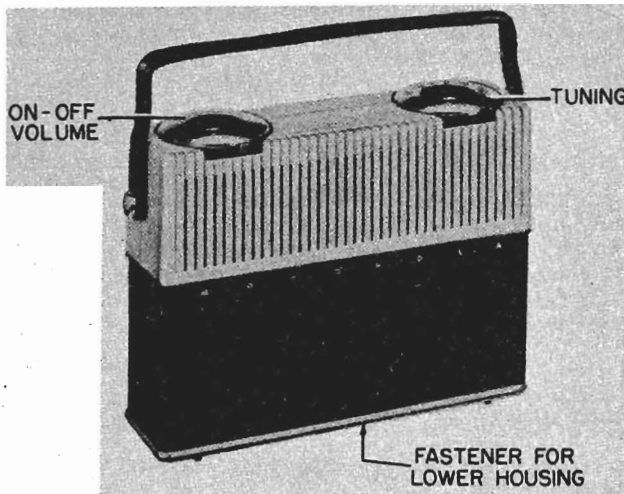

FIGURE 1. 52B1U RECEIVER

OPERATING INSTRUCTIONS

TO REMOVE LOWER HOUSING. Insert a large coin into the fastener on the bottom of the receiver (see Figure 1 for location), and rotate it counterclockwise until the housing is released. Then pull off the housing.

TO REPLACE LOWER HOUSING. Make certain, when the lower housing is assembled to the upper portion of the set, that the fastener is on the side of the housing which faces the speaker. Rotate the fastener clockwise until the housing is locked into place.

HOUSE CURRENT OPERATION. The power cord is located inside the cabinet and can be reached by removing the lower housing. Uncoil the line cord from its retainer and pass it through the slot in the end of the housing. Plug the cord into any 117 volt AC or DC power outlet. Reverse the plug in the outlet if the receiver does not operate from DC power. When operating from AC, reception may sometimes be improved by reversing the power plug in the outlet. It is not necessary that batteries be installed if the receiver is to be operated only from house power lines.

BATTERY OPERATION. Remove the lower housing and install batteries by following the instructions on the label located inside the housing, or refer to Figure 2. Plug the power line cord into the receptacle on the chassis, or the receiver will not play from batteries. If the radio is to be operated for a long period of time from house power lines,

or is to be placed in storage, remove the batteries and keep them in a cool place. **IMPORTANT:** Never leave low or run-down batteries in the receiver, as they will leak or swell and damage it.

CONTROLS. The volume control and power switch are combined and are operated with the **VOLUME** knob (see Figure 1). Select stations with the **TUNING** knob. The markings around the **TUNING** knob can be read in kilocycles by adding one zero to the figures.

ANTENNA. A Ferrite Magnetic Iron Core Antenna is built into this receiver. Because of the slightly directional characteristics of the built-in antenna, reception from some stations may be improved by rotating the receiver. In extremely noisy locations, rotate the set until minimum noise and maximum signal pickup are obtained.

BATTERY REPLACEMENT. If low volume or fuzzy tone is noticed when operating from batteries, replace the flashlight cells. Normally, the 67-1/2 volt "B" battery will last for 3 or 4 changes of the flashlight cells. Complete battery replacement instructions will be found inside the lower housing of the receiver, or refer to Figure 2. **NOTE:** The condition of the batteries will not affect operation of the receiver from the house power lines.

SERVICE NOTES

The chassis of this receiver is isolated from the AC power line circuit by a capacitor-choke assembly to eliminate the shock hazard when handling the receiver. However, as an additional precaution when aligning or servicing the receiver from AC, an isolation transformer should be inserted between the power line and the chassis.

The tubes are exposed when the lower housing is removed. It is not necessary to remove the chassis to replace tubes.

TO REMOVE THE CHASSIS FROM THE CABINET:

1. Remove the lower housing (see Operating Instructions).
2. Pull off the knobs.
3. Remove the two hex head screws under the knobs.
4. Pull outward on the two studs which hold the handle and lift off the top housing.

ALIGNMENT

NOTE: The receiver may be operated either from batteries or from the commercial power lines during alignment. If AC power is used, it is recommended that an isolation transformer be placed between the power line and the receiver. If an isolation transformer is not available, connect the low side of the signal generator to B- through a .1 mf capacitor.

1. Connect a low range output meter across the speaker voice coil.
2. Connect the low side of the signal generator to B-.
3. Set the signal generator for 400 cycle, 30% modulation.

4. Turn the receiver volume control to maximum.
5. Use a small fibre screwdriver for aligning the IF and diode transformers.
6. Adjust the signal generator output to produce .40 volts (.05 watts) across the voice coil. As stages are aligned, reduce the generator output to maintain the .40 volt level, to avoid overloading the receiver.
7. See Figure 3 for adjusting locations and the following chart for procedure.

ALIGNMENT CHART

STEP	DUMMY ANTENNA	GENERATOR CONNECTION	GENERATOR FREQUENCY	GANG SETTING	ADJUST	REMARKS
IF ALIGNMENT						
1.	.1 mf	Grid of conv (pin 6, 1R5)	455 Kc	Fully open	1, 2 & 3 (IF cores)	Adjust for maximum.
RF ALIGNMENT						
2.	.1 mf	Grid of conv (pin 6, 1R5)	1620 Kc	Fully open	4 (Osc)	Adjust for maximum.
3.	-	-	-	-	-	Install batteries in chassis, leaving output meter connected to speaker.
4.	-	Radiation loop*	1400 Kc	Tune for max.	5 (Ant)	Adjust for maximum.

*Connect generator output across 5" diameter, 5 turn loop and couple inductively to receiver loop. Keep loops at least 12" apart.

MODELS 52B1U, 52B2U,
52B3U, 52B4U, Ch. HS-305

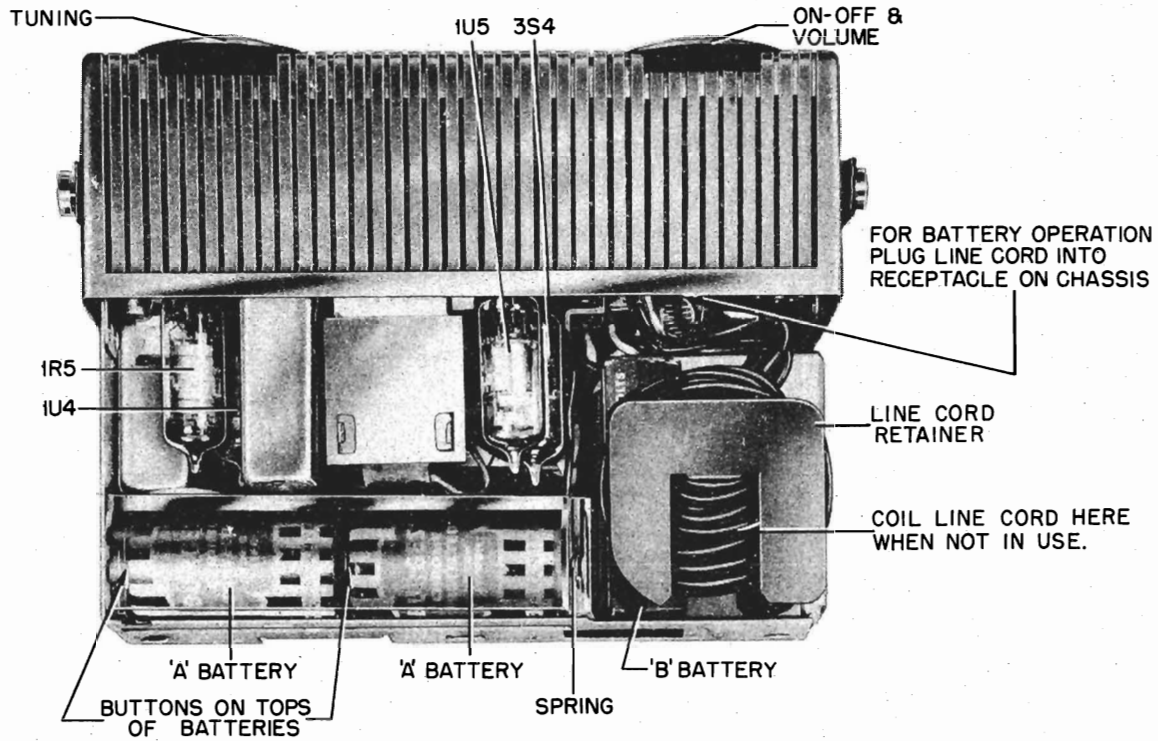
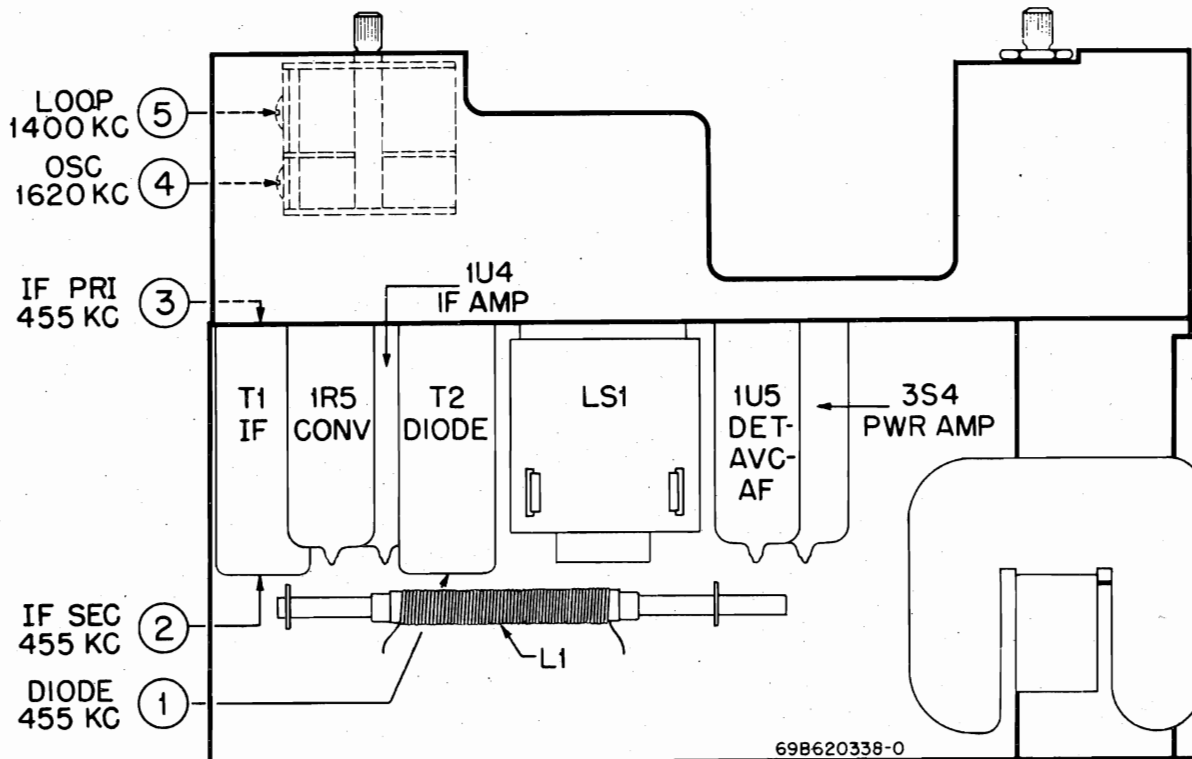

FIGURE 2. REAR VIEW OF RECEIVER



69B620338-0

FIGURE 3. TUBE AND TRIMMER LOCATIONS

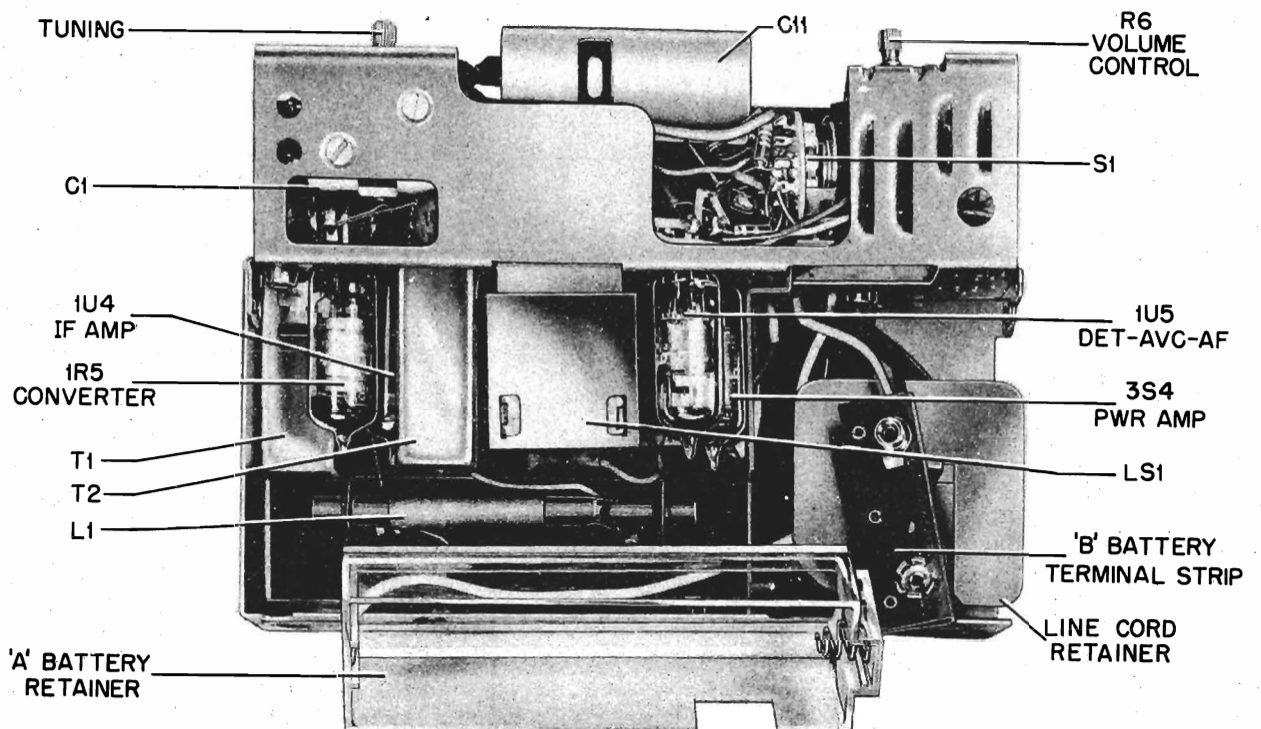
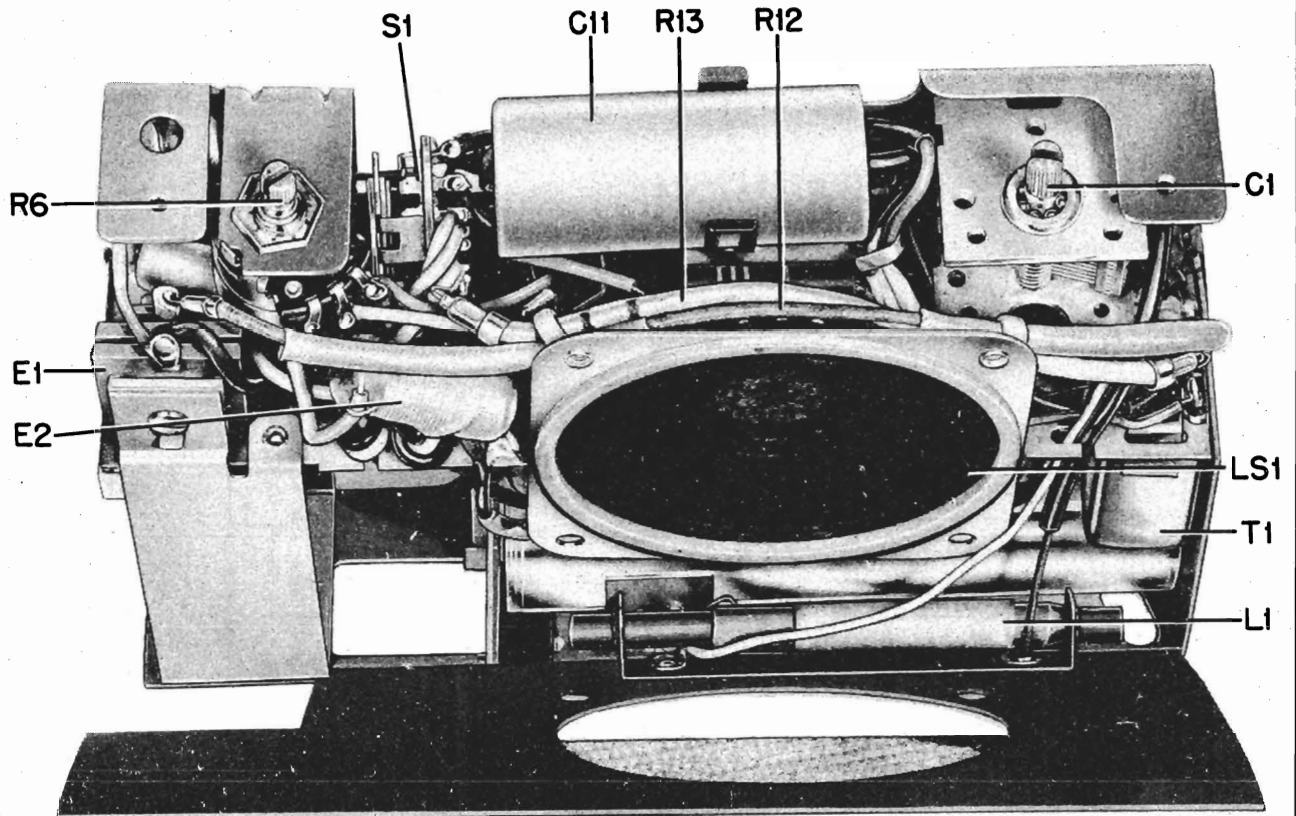

FIGURE 4. PARTS LOCATIONS

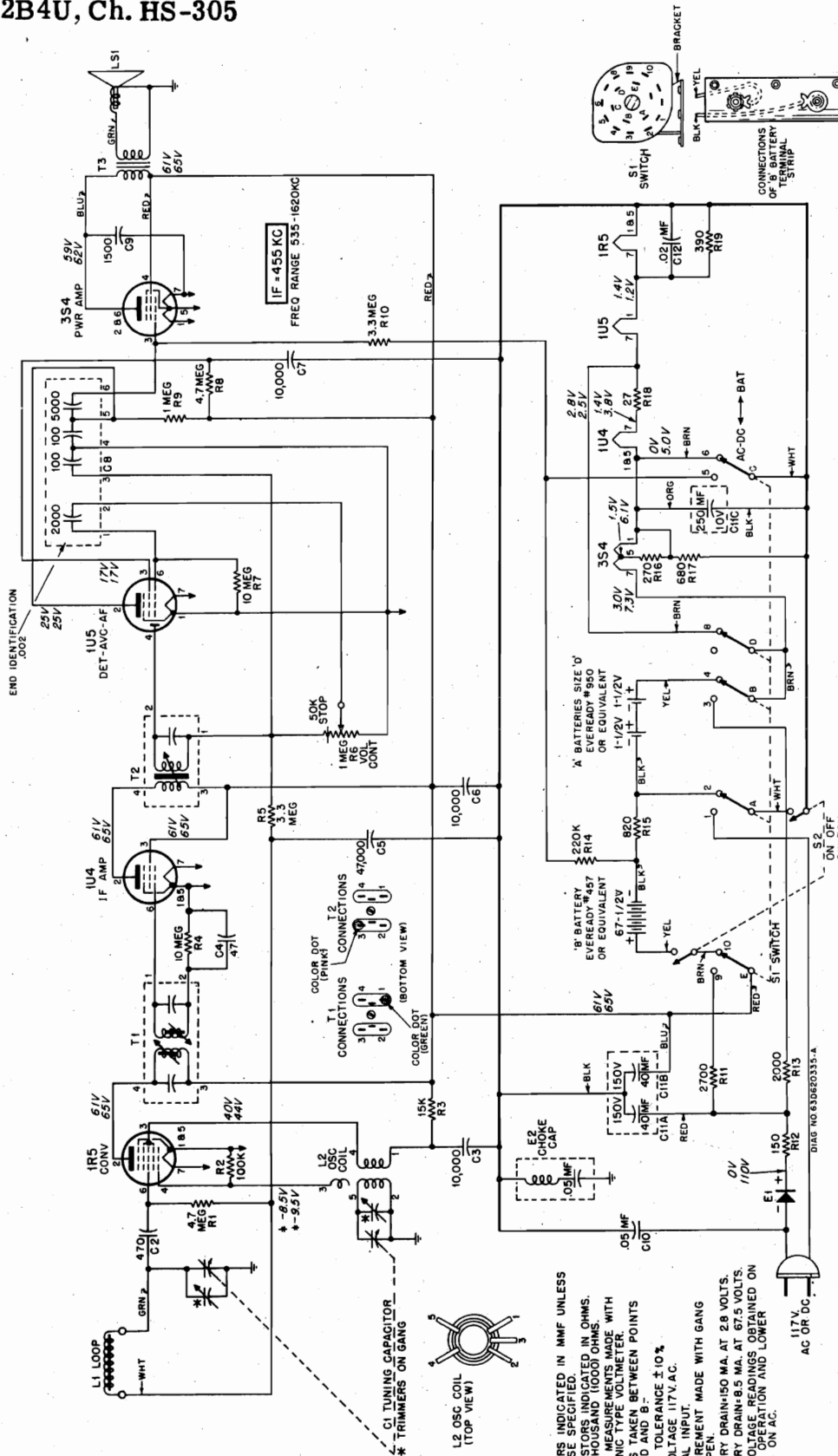

FIGURE 5. SCHEMATIC DIAGRAM

NOTE:-
 CAPACITORS INDICATED IN MMF UNLESS OTHERWISE SPECIFIED.
 ALL RESISTORS INDICATED IN OHMS.
 VOLTAGE MEASUREMENTS MADE WITH ELECTRONIC TYPE VOLTMETER.
 VOLTAGES TAKEN FROM BETWEEN POINTS INDICATED AND B-.
 VOLTAGE TOLERANCE $\pm 10\%$.
 INPUT VOLTAGE 117V. A.C.
 NO SIGNAL INPUT.
 * MEASUREMENT MADE WITH GANG FULLY OPEN.
 X BATTERY DRAIN-150 MA. AT 2.8 VOLTS.
 B BATTERY DRAIN-8.5 MA. AT 67.5 VOLTS.
 UPPER VOLTAGE READINGS OBTAINED ON READING ON AC.

PARTS LIST

NOTE: When ordering parts, specify model and chassis number of set in addition to part number and description of part.

Ref. No.	Part Number	Description	List Price	Ref. No.	Part Number	Description	List Price
CHASSIS PARTS - ELECTRICAL				Transformers			
Capacitors				T-1	24K611438	IF transformer (green dot): 455 Kc; complete.....	1.35
C-1	19B611415	Variable: 2-gang.....	2.60	T-2	24K611439	Diode transformer (pink dot): 455 Kc; complete.....	1.35
C-2	21R115856	Ceramic: 470 mmf 500V.....	.20	T-3	25B611377	Output transformer.....	1.05
C-3	21R115611	Ceramic, disc: 10,000 mmf 450V	.25	Part Number Description List Price			
C-4	21R115593	Ceramic, disc: 47 mmf 500V..	.15	CHASSIS PARTS - MECHANICAL			
C-5	8R490232	Molded, paper: 47,000 mmf 400V	.25	1X611568	Baffle, speaker: fibre; includes loop mtg insulator and grille cloth.....	.95	
C-6	21R115611	Ceramic, disc: 10,000 mmf 450V	.25	43A692012	Bushing, strain relief: line cord (use with 43K692013).....	.05	
C-7	21R115611	Ceramic, disc: 10,000 mmf 450V	.25	42A620012	Clip, baffle retaining (mts baffle to spkr).....	.20	
C-8	21K691992	Ceramic, multiple: 2000, 100, 100, 5000 mmf.....	.65	42K620055	Clip, electrolytic mtg.....	.10	
C-9	21A701029	Ceramic, disc: 1500 mmf 500V	.25	42B485548	Clip, IF trans mtg.....	.20	
C-10	8K471635	Paper: .05 mf 400V.....	.25	13A620221	Cloth, grille (on spkr baffle)....	.25	
C-11	23K611436	Electrolytic: 40-40 mf/150V, 250 mf/10V.....	3.10	30K611437	Cord, line: with plug; 6 ft long..	.85	
C-12	8R9817	Paper: .02 mf 100V.....	.25	14A611424	Insulator, rectifier: fibre (under selenium rectifier).....	.40	
Rectifier				29R3020	Lug, soldering (battery contact -in "A" battery retainer).....	.20	
E-1	48B791092	Rectifier, selenium: half- wave; 65 ma.....	1.40	2S7051	Nut, hex: Palnut; 3/8-32 x 9/16 (volume control mtg).....	.15	
Choke & Capacitor				15B611416	Retainer, "A" battery: plastic....	.20	
E-2	24K611433	Choke & .05 mf paper capaci- tor.....	.40	43K692013	Retainer, strain relief: line cord (use with 43A692012).....	.05	
Coils				41K680029	Spring, battery contact (in "A" battery retainer).....	.20	
L-1	24B611428	Antenna Loop: with core.....	.70*	9K600976	Socket, tube: miniature; 7-prong..	.15	
L-2	24B611429	Oscillator coil.....	.90	31K611298	Strip, "B" battery terminal: with leads.....	.25	
Speaker				CABINET PARTS			
	1X611472	Speaker & Output Transformer Assembly.....	4.95* exch 3.70	46A620235	Button, plug (in top housing)..	.20	
LS-1	50C611578	Speaker: 3-1/2" PM; 3.2 ohm VC; less output trans.....	3.75* exch 2.80	13A611521	Cloth, grille (on chassis insulator)	.25	
or	50C620143			3K620214	Fastener, locking (locks lower housing).....	.35	
Resistors				55C611432	Handle.....	1.10	
Note: All resistors are insulated, carbon type unless otherwise specified.				1X620236	Housing, lower: plastic; with locking fastener.....	5.80*	
R-1	6R2122	4.7 meg 20% 1/2W.....	1.20	15D61I323	Housing, top: less handle and studs	3.80*	
R-2	6R6031	100,000 10% 1/2W.....	1.20	1B611479	Insulator, chassis: fibre; with grille cloth (inside top housing)	1.00	
R-3	6R6477	15,000 10% 1/2W.....	1.20	36C611430	Knob, control (volume).....	.45	
R-4	6R2109	10 meg 20% 1/2W.....	1.20	36K611431	Knob, control (tuning).....	.45	
R-5	6R2118	3.3 meg 20% 1/2W.....	1.20	41A611538	Spring, compression (on handle mtg stud).....	.15	
R-6	18A692018	Volume control: 1 meg; with switch.....	1.20	46A611497	Stud, handle mtg: less spring....	.15	
R-7	6R2109	10 meg 20% 1/2W.....	1.20	4K601456	Washer, "C" (on handle mtg stud).....	.15	
R-8	6R2122	4.7 meg 20% 1/2W.....	1.20	4A21577	Washer, "C" (locking fastener mtg).....	.50	
R-9	6R6004	1 meg 20% 1/2W.....	1.20	4A620230	Washer, fibre (locking fastener mtg).....	.15	
R-10	6R2118	3.3 meg 20% 1/2W.....	1.20	4S1706	Washer, flat: 3/8 x .203 x .033; steel (locking fastener mtg)per/c	.50	
R-11	6R5577	2700 10% 1/2W.....	1.20	4K620224	Washer, shoulder: fibre (chassis mtg to top housing).....	.15	
R-12	17A620037	Wire wound, flexible: 150 ohms 4W.....	.35				
R-13	17K620038	Wire wound, flexible: 2000 ohms 10W.....	.50				
R-14	6R6015	220,000 20% 1/2W.....	1.20				
R-15	6R6269	820 10% 1/2W.....	1.20				
R-16	6R6432	270 10% 1/2W.....	1.20				
R-17	6R6040	680 10% 1/2W.....	1.20				
R-18	6R5683	27 10% 1/2W.....	1.20				
R-19	6R5554	390 10% 1/2W.....	1.20				
Switch							
S-1	40B611426	Rotary switch, 5PDT (AC/DC, battery selector).....	1.15				

PRICES SUBJECT TO CHANGE WITHOUT NOTICE

*Plus Federal Excise Tax At Current Rate

GENERAL INFORMATION

Cabinet colors are:

Model	Color
52B2U	Green
52B3U	Brown
52B4U	Tan

This supplement contains a complete cabinet Replacement Parts List for receiver models 52B2U, 52B3U, and 52B4U. Except for the lower housing locking nut, the chassis parts and 52B1U cabinet parts are the same as listed in 52B1U

On later model HS-305 chassis, the welded "tee" nut, which held the lower housing locking fastener, was replaced with a removable nylon nut and its retainer. The nut and retainer are listed below.

PARTS LIST SUPPLEMENT

NOTE: When ordering parts, specify model and chassis number of set in addition to part number and description of part. The following parts are revisions of or additions to the original items listed in the HS-305 Service Manual.

Part Number	Description	List Price	Part Number	Description	List Price
CHASSIS PARTS SUPPLEMENT					
2A620252	Nut, square: 10-32 x 7/16; nylon (lower housing locking)	.05	15K621226	Housing, top: satin brass finish; less handle and studs	3.80*
2K620251	Retainer, nut (for lower housing locking nut)	.05	1B611479	Insulator, chassis: fibre; with grille cloth (inside top housing)	.45
MODEL 52B2U, 52B3U, 52B4U CABINET PARTS					
46K621231	Button, plug: satin brass finish (in top housing)	.15	36K621220	Knob, volume control: green (52B2U)	.45
13A611521	Cloth, grille (on chassis insulator)	.25	36K621222	Knob, volume control: brown (52B3U)	.45
3A621293	Fastener, locking: bright brass finish (locks lower housing)	.15	36K621224	Knob, volume control: tan (52B4U)	.45
55K621229	Handle: green (52B2U)	1.10	36K621221	Knob, tuning control: green (52B2U)	.45
55K621228	Handle: brown (52B3U)	1.10	36K621223	Knob, tuning control: brown (52B3U)	.45
55K621227	Handle: tan (52B4U)	1.10	36K621225	Knob, tuning control: tan (52B4U)	.45
1V621252	Housing, lower: plastic; green; with locking fastener (52B2U)	6.95*	41A611538	Spring, compression (on handle mtg stud)	.15
1V621253	Housing, lower: plastic; brown; with locking fastener (52B3U)	6.95*	46A621295	Stud, handle mtg: less spring; bright brass finish	.15
1V621254	Housing, lower: plastic; tan; with locking fastener (52B4U)	6.95*	4K601456	Washer, "C" (on handle mtg stud)	.15
			4A21577	Washer, "C" (locking fastener mtg)	.15
			4A620230	Washer, fibre (locking fastener mtg)	.15
			4S1706	Washer, flat: 3/8 x .203 x .033; steel (locking fastener)	.50
			4K620224	Washer, shoulder: fibre (chassis mtg to top housing)	.15

PRICES SUBJECT TO CHANGE WITHOUT NOTICE
*Plus Federal Excise Tax At Current Rate

GENERAL INFORMATION

TYPE - AC-DC table model superheterodyne receiver with loop antenna.

TUNING RANGE - 535 to 1620 Kc IF - 455 Kc

TUBE COMPLEMENT - 12BE6 - Converter
12BA6 - IF Amplifier
12AT6 - Detector, AVC & 1st AF Amp
50C5 - Power Amplifier
35W4 - Rectifier

POWER SUPPLY - 117 volts AC or DC, 35 watts

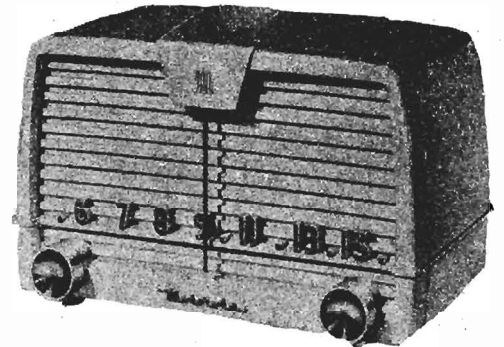

INSTALLATION & OPERATING INSTRUCTIONS

POWER SWITCH AND VOLUME CONTROL. Operated with the left-hand knob. **NOTE:** Reverse the line cord plug in the wall outlet if radio does not operate from DC. When operating from AC, reversing the line cord plug in the wall outlet may sometimes improve reception and reduce hum.

TUNING. Tune stations with right-hand knob.

ANTENNA. A loop antenna is built into this receiver, eliminating the need for an external antenna. Reception from some stations may be improved by

rotating the whole receiver; this is due to the slight directional characteristic of the loop antenna. In extremely noisy locations, rotate the entire receiver till minimum noise and maximum signal pickup are obtained. For additional pickup, an external antenna may be connected by winding lead-in wire in slots on radio back panel.

GROUND. Never connect antenna or chassis to water pipe, radiator or other ground, as one side of the power line is connected directly to chassis.

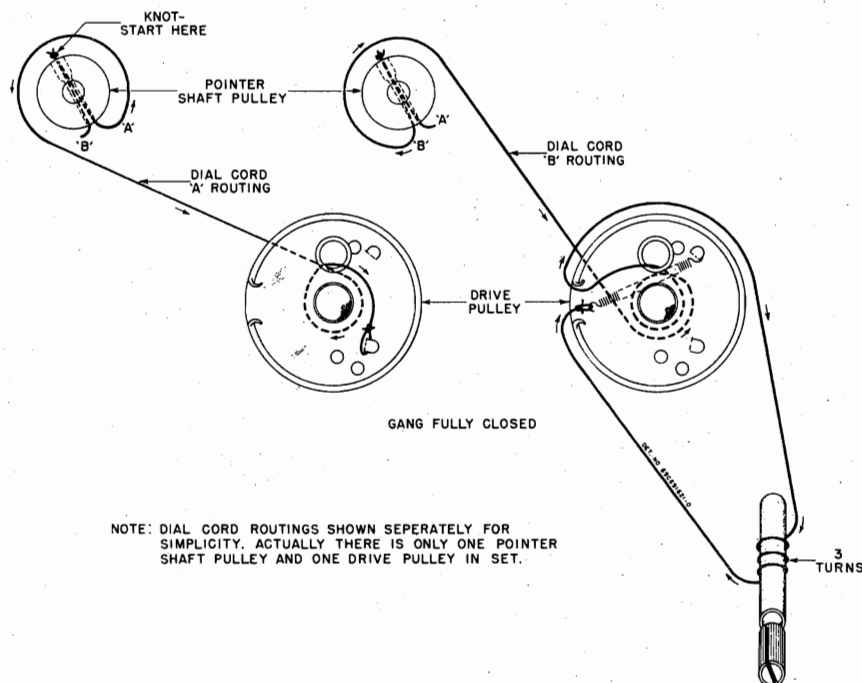

FIGURE 1. DIAL RESTRAINING DETAIL

MODELS 59H11,
59H12I, Ch. HS-206

SERVICE NOTE

The chassis of this receiver is connected directly to the power line. When operating chassis (from AC line) outside of its cabinet, use an isolation transformer between power line and receiver to reduce possibility of electrical shock. If iso-

lation transformer is not available, check the AC voltage between chassis and bench ground; if there is any indication of voltage, reverse the line plug before handling set.

TO REMOVE CHASSIS FROM CABINET

1. Set pointer to extreme low frequency end to expose pointer setscrew. Loosen pointer setscrew with a slab head wrench.
2. Remove the knobs; they pull off.
3. Remove the two split plugs that hold top of loop panel to cabinet.
4. Remove the two screws that hold the chassis to the cabinet. These screws are accessible through slots in the loop panel.

ALIGNMENT

If AC power is used, use an isolation transformer between power line and receiver. If isolation transformer is not available, connect low side of signal generator to chassis through .1 mf capacitor.

voice coil and set volume control at maximum. For greatest accuracy, keep output of receiver at approximately .05 watt (.05 watt = .40 volt on output meter) throughout alignment by reducing signal generator output as stages are brought into alignment. Use a small fibre screwdriver for aligning IF & diode transformers.

Connect low range output meter across speaker

STEP	DUMMY ANTENNA	GENERATOR CONNECTION	GENERATOR FREQUENCY	GANG SET TO	ADJUST	REMARKS
IF ALIGNMENT 1.	.1 mf	Rear stator of tuning capacitor	455 Kc	Gang opened	1, 2, 3 & 4	Adjust for maximum.
RF ALIGNMENT 2.	-	Radiation loop*	1620 Kc	Gang fully opened	5	Adjust for maximum.
3.	-	Radiation loop*	1400 Kc	Tune for maximum	6	Adjust for maximum.

* Connect generator output to 5" diameter, 3 turn loop and couple to receiver loop. Keep loops at least 12" apart.

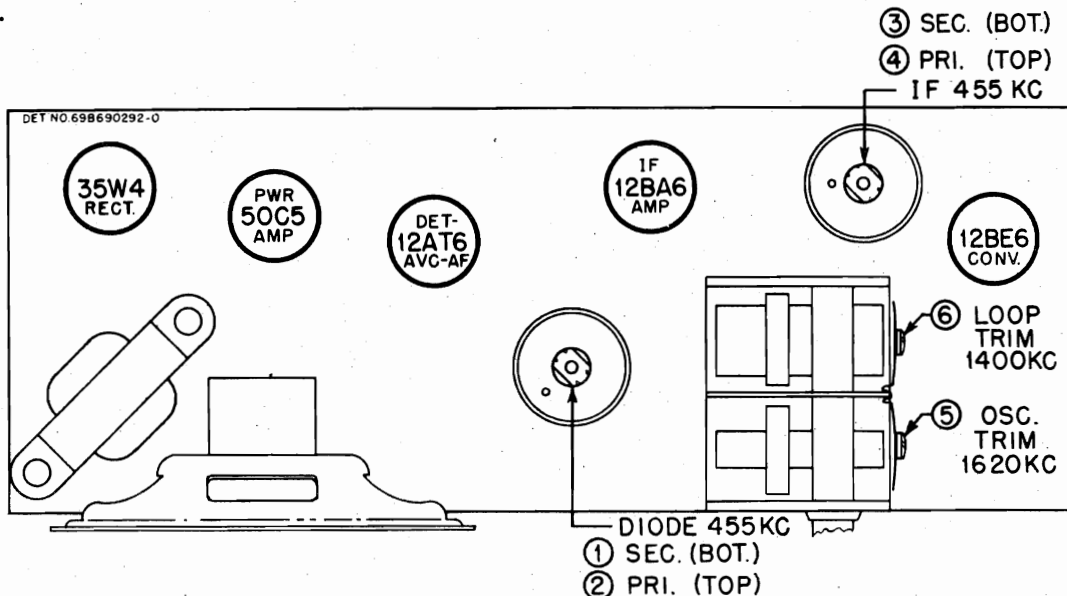
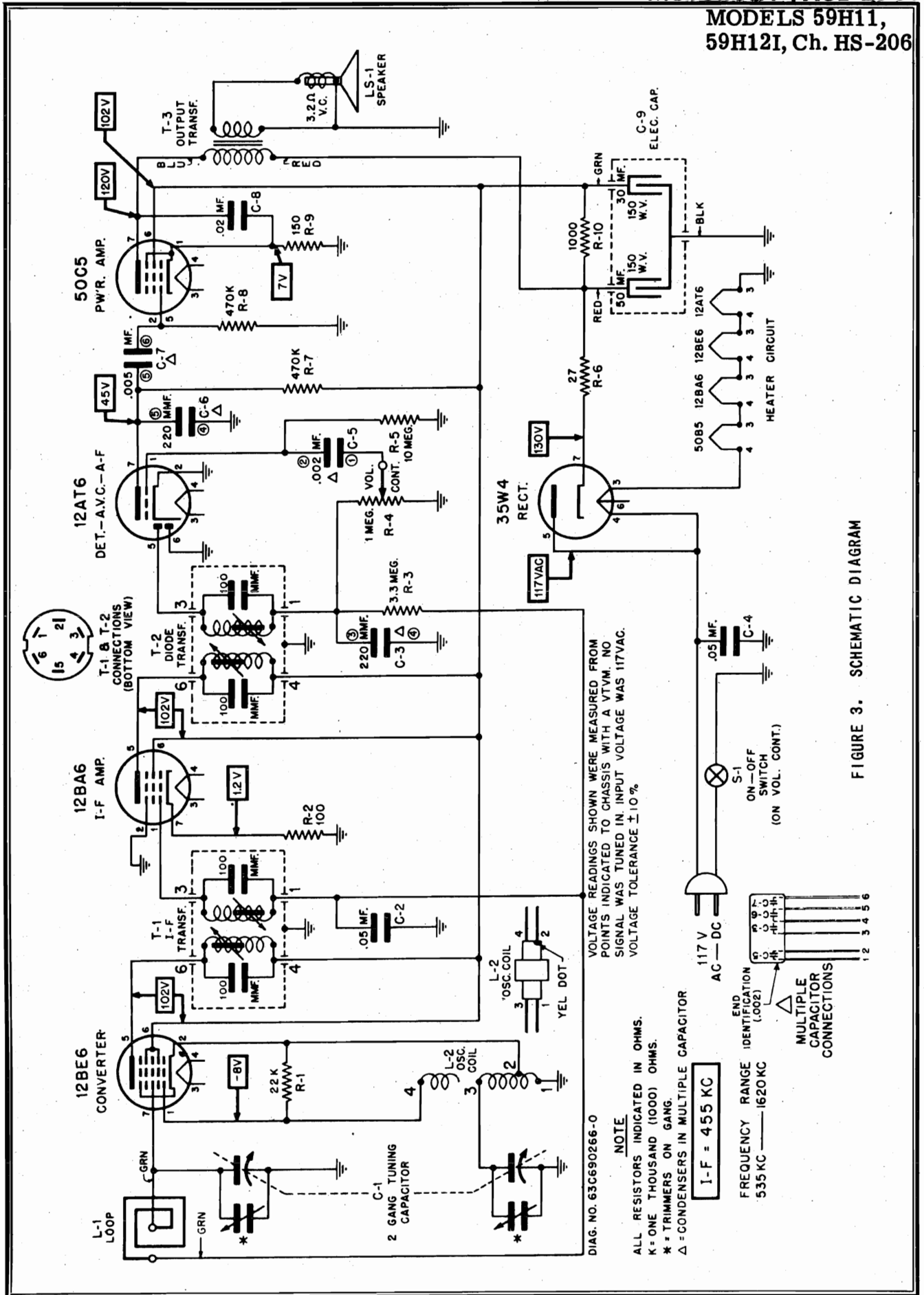

FIGURE 2. TUBE & TRIMMER LOCATION



VOLTAGE READINGS SHOWN WERE MEASURED FROM POINTS INDICATED TO CHASSIS WITH A VTVM. NO SIGNAL WAS TUNED IN INPUT VOLTAGE WAS 117VAC. VOLTAGE TOLERANCE ± 10%.

DIAG. NO. 63C690266-0

NOTE

ALL RESISTORS INDICATED IN OHMS.
 K = ONE THOUSAND (1000) OHMS.
 * = TRIMMERS ON GANG.
 Δ = CONDENSERS IN MULTIPLE CAPACITOR

I-F = 455 KC

FREQUENCY RANGE IDENTIFICATION (.002)
 535 KC — 1620 KC

AC — DC

ON-OFF SWITCH (ON VOL. CONT.)

MULTIPLE CAPACITOR CONNECTIONS

FIGURE 3. SCHEMATIC DIAGRAM

MODELS 59H11,
59H12I, Ch. HS-206

PARTS LIST

REF. NO.	PART NO.	DESCRIPTION	LIST PRICE	PART NO.	DESCRIPTION	LIST PRICE
CHASSIS PARTS - ELECTRICAL						
CAPACITORS						
C-1	1X690702	Variable, 2-gang: includes pulley	2.65	2S7051	Palnut, hex: 3/8-32 x 9/16; cad pl (volume control mtg)doz	.15
C-2	8R9821	Paper: .05 mf 200V20	5S7771	Rivet: .088 x 3/16; stl; pol nkl (tube socket mtg & chassis mtg)50
C-3, 5, 6, 7	21B482847	Ceramic, multiple: 220 mf; .002 mf; 220 mf; .005 mf.....	.65	5S7707	Rivet: .122 x 5/32; stl; pol nkl (transformer mtg)....per/c	.50
C-4	8R9816	Paper: .05 mf 400V20	5S7701	Rivet: .122 x 3/16; stl; pol nkl (tuning shaft mtg)...per/c	.50
C-8	8R9802	Paper: .02 mf 400V20	5S7703	Rivet: .122 x 7/32; stl pol nkl (pointer brkt mtg)...per/c	.50
C-9	23K482857	Electrolytic: 50-30 mf/150V ...	1.00	5S7703	Screw, machine: 6-32 x 1/2; plain; locking type; hex head; cad pl (gang mtg)....doz	.15
COILS						
L-1	24C691086	Antenna loop: includes back panel	1.00	3S2294	Screw, machine: 8-32 x 1/4; type 1; plain hex head; cad pl (loop mtg)15
L-2	24K482855	BC oscillator60	3S7477	Screw, sheet metal: #6 x 3/8; PKZ plain hex head; cad pl (loop brkt mtg)50
SPEAKER						
LS-1	50C478138	Speaker, PM: 4"; 3.2 ohm VC....	2.60	3S3398	Screw, sheet metal: #8 x 1/4; PKZ plain hex head; cad pl (speaker mtg)50
		exch	1.95	3S7454	Screw, sheet metal: #8 x 1/4; PKZ plain hex head; cad pl (tuning shaft and pointer shaft mtg)....per/c	.50
RESISTORS						
Note: All resistors are insulated carbon type unless otherwise specified.						
R-1	6R6028	22,000 20% 1/2W	1.00	47A691075	Shaft, pointer: aluminum20
R-2	6R6018	100 20% 1/2W	1.00	47K691081	Shaft, tuning: cad pl15
R-3	6R2118	3.3 meg 20% 1/2W	1.00	26K485936	Shield, coil20
R-4	18A70032	Volume Control: 1 meg; includes ON-OFF switch	1.00	26A481521	Shield, spring (tube shield)doz	.50
R-5	6R2109	10 meg 20% 1/2W	1.00	41A14111	Spring, tension coil40
R-6	6R5683	27 10% 1/2W	1.00	9A472534	Socket, tube: miniature15
R-7	6R6032	470,000 20% 1/2W	1.00	22S7906	Staple, flathead (on tuning cord)50
R-8	6R6032	470,000 20% 1/2W	1.00	4A70015	Washer, 'C' (tuning shaft and pointer shaft mtg)....per/c	.50
R-9	6R3992	150 20% 1/2W	1.00	4S7633	Washer, flat: 9/16 x 11/64 x .033; stl; cad pl (loop mtg)15
R-10	6R3953	1000 20% 1W15	4K482859	Washer, insulated shoulder (loop brkt mtg)15
		doz	1.45			
SWITCH						
S-1	-	SPST Switch: part of volume control R-4	-	14A11493	Washer, insulating: fibre (pointer brkt mtg)35
TRANSFORMERS						
T-1	24B482863	IF, 455 Kc: complete	1.70			
T-2	24B482865	Diode, 455 Kc: complete	1.70			
T-3	25K485973	Output Transformer65			
CHASSIS PARTS - MECHANICAL						
	37A27142	Band, rubber: special (electrolytic mtg).....per/c	.50	16E691141	Cabinet, table model: plastic; mahogany (59H11)	-
	7K485971	Bracket, loop mtg05	16K691142	Cabinet, table model: plastic; ivory (59H12I)	-
	1X691092	Bracket, pointer mtg (mounts pointer to chassis)35	36K691121	Knob, control: mahogany (59H11)	.35
	7A77337	Bracket, tuning shaft mtg (cad pl)	.05	36K691122	Knob, control: ivory (59H12I) .	.35
	11M8944	Cord, dial: 18" black10	38A25507	Plug, split (loop & back to cabinet mtg)15
	30A470651	Cord, line & plug: 6 ft long...	.75	52A691073	Pointer & bushing: does not include setscrew35
	46K680318	Core, iron: threaded (for T-1 & T-2)10	3S7374	Screw, machine: 8-32 x 5/16; plain hex head; cad pl (chassis mtg)50
	5A19658	Eyelet, spacer (gang mtg)....doz	.20	3S7100	Setscrew: 8-32 x 5/16; slab head; cad pl (pointer and bushing mtg)35
	5A70404	Grommet, rubber (gang mtg)....doz	.60			
	14A482844	Insulator, cord outlet25			
CABINET PARTS						

PRICES SUBJECT TO CHANGE WITHOUT NOTICE

**MODELS 52L1, 52L2,
52L3, Ch. HS-327**
GENERAL INFORMATION

TYPE - Three-power (AC/DC, Battery) portable radio receiver. Four miniature type tubes and a selenium rectifier are used in a superheterodyne circuit.

RECEIVER MODELS	Model	Color
	52L1	Green
	52L2	Maroon
	52L3	Gray

TUNING RANGE - 535 to 1620 Kc **IF** - 455 Kc

POWER SUPPLY - Operates from 117V AC/DC (15 watts) or from the following batteries:

2 - 1-1/2V "A" batteries (Eveready #964 or equivalent)

1 - 67-1/2V "B" battery (Eveready #477 or equivalent)

TUBE COMPLEMENT	Type	Function
	1R5	Converter
	1U4	IF Amplifier
	1U5	Det, AVC & 1st AF Amp
	3S4	Power Amplifier
	Rectifier	Selenium type -for AC/DC operation

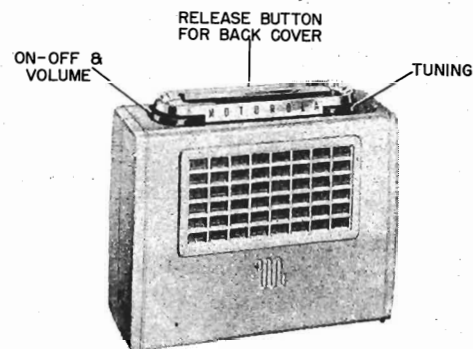

FIGURE 1. FRONT VIEW OF RECEIVER

OPERATING INSTRUCTIONS

TO OPEN BACK COVER. Press the release button on the top of the cabinet and, with the fingers, pull the back cover open. When closing the cover, be careful not to pinch the power line cord or other leads between the cover and the cabinet.

HOUSE CURRENT OPERATION. The power cord is located inside the cabinet and can be reached by opening the back cover. Pass the cord through the slot on the side of the receiver before closing the cover. Plug the cord into any 117 volt AC or DC power outlet. Reverse the plug in the outlet if the receiver does not operate from DC power. When operating from AC, reception may sometimes be improved by reversing the power plug in the outlet. It is not necessary that batteries be installed if the receiver is to be operated only from house power lines.

BATTERY OPERATION. Open the back cover and install the batteries by following the instructions on the label located inside the cover, or refer to Figure 2. Plug the power line cord into the receptacle on the chassis, or the receiver will not operate from batteries. If the radio is to be operated for a long period of time from house power lines, or is to be placed in storage, remove the batteries and keep

them in a cool place. **IMPORTANT:** Never leave low or run-down batteries in the receiver, as they will swell or leak and damage the set.

CONTROLS. The volume control and power switch are combined and are operated with the VOLUME knob (see Figure 1). Select stations with the TUNING knob. The markings on the dial scale can be read in kilocycles by adding two zeros to the figures.

ANTENNA. A Ferrite Magnetic Iron Core Antenna is built into this receiver. Because of the slightly directional characteristics of the built-in antenna, reception from some stations may be improved by rotating the receiver. In extremely noisy locations, rotate the set until minimum noise and maximum signal pickup are obtained.

BATTERY REPLACEMENT. Replace the batteries when low volume or fuzzy tone is noticed. Complete battery replacement instructions will be found inside the back cover, or refer to Figure 2. **NOTE:** The condition of the batteries will not affect operation of the receiver from the house power lines.

SERVICE NOTES

The chassis of this receiver is isolated from the AC power line circuit by a capacitor to eliminate the shock hazard when handling the receiver. However, as an additional precaution when aligning or servicing the receiver from AC, an isolation transformer should be inserted between the power line and the chassis.

The tubes are exposed when the rear cover is opened. It is not necessary to remove the chassis to replace tubes.

TO REMOVE THE CHASSIS FROM THE CABINET

Refer to Figure 2 for the locations of the items mentioned below.

1. Open the back cover and remove the batteries.
2. Remove the two wire clips which hold the plastic retainer blocks at each end of the "A" battery compartment.

3. Remove the screw holding the cover stop cord to the chassis.

4. Remove the chassis mounting screws, at the four corners of the chassis.

5. Slide the chassis, with knobs and escutcheon, from the cabinet.

6. Remove one of the handle clips. (Squeeze the sides of the clip until it is released from the escutcheon.)

7. Remove the two screws located under the handle, and lift off the escutcheon.

8. Pull off the knobs.

REAR COVER HINGE INSTALLATION

The proper method for installing a new hinge is shown in Figure 3. Note that the under side of the cabinet should rest on an iron block during the heating process to prevent the formation of a heat bubble on the bottom of the cabinet.

MODELS 52L1, 52L2,
52L3, Ch. HS-327

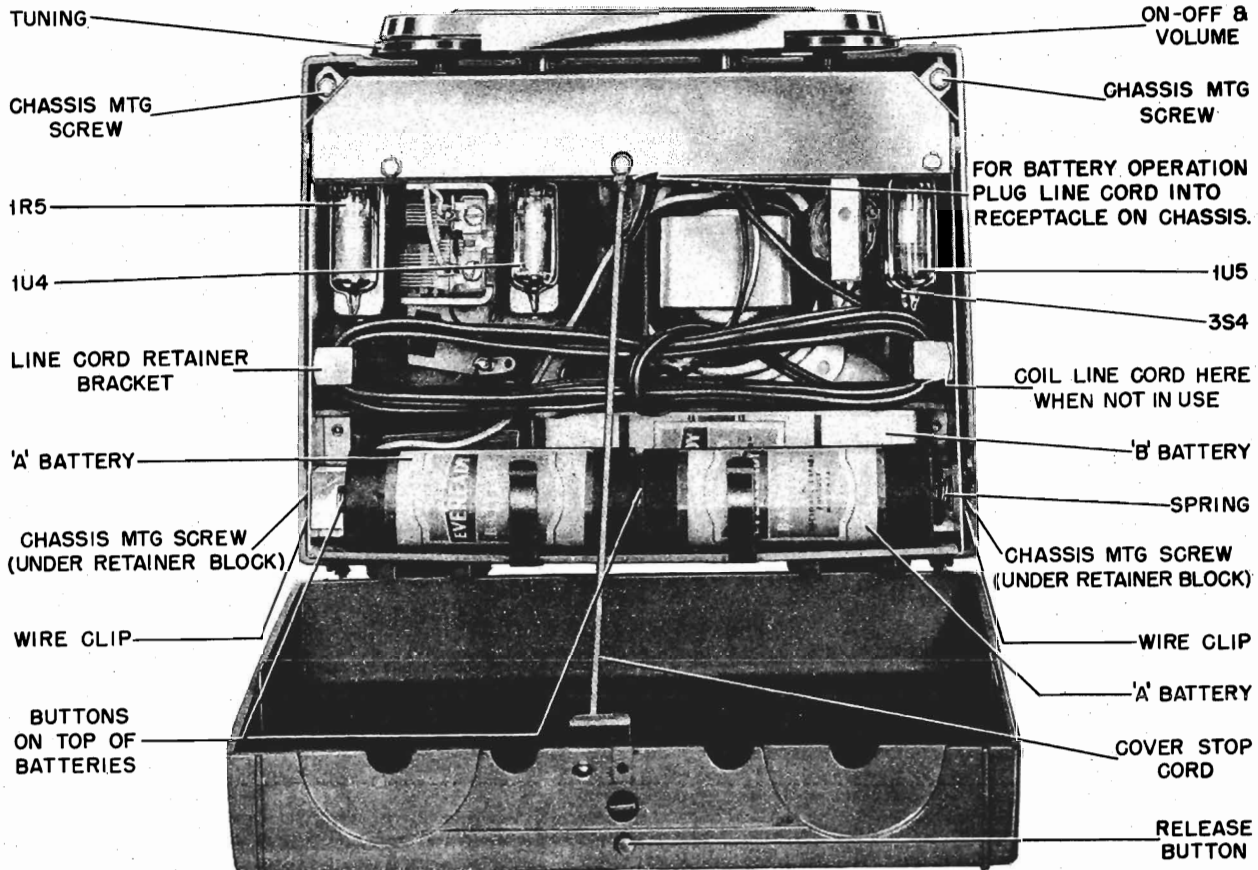

FIGURE 2. REAR VIEW OF RECEIVER

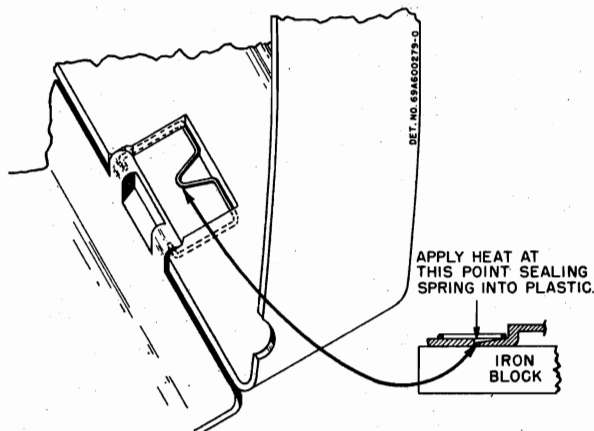

FIGURE 3. REAR COVER HINGE INSTALLATION

ALIGNMENT

NOTE: The receiver may be operated either from batteries or from the commercial power lines during alignment. If AC power is used, it is recommended that an isolation transformer be placed between the power line and the receiver. If an isolation transformer is not available, connect the low side of the signal generator to B- through a .1 mf capacitor.

PROCEDURE:-

1. Connect a low range output meter across the speaker voice coil.
2. Connect the low side of the signal generator to B-.

3. Set the signal generator for 400 cycle, 30% modulation.
4. Turn the receiver volume control to maximum.
5. Use a small fibre screwdriver for aligning the IF and diode transformers.
6. Adjust the signal generator output to produce .40 volts (.05 watts) across the voice coil. As stages are aligned, reduce the generator output to maintain the .40 volt level, to avoid overloading the receiver.
7. See Figure 4 for adjusting locations and the following chart for procedure.

ALIGNMENT CHART

STEP	DUMMY ANTENNA	GENERATOR CONNECTION	GENERATOR FREQUENCY	GANG SETTING	ADJUST	REMARKS
IF ALIGNMENT						
1.	.1 mf	Ant section of gang (green loop lead)	455 Kc	Fully open	1, 2 & 3 (IF cores)	Adjust for maximum.
RF ALIGNMENT						
2.	-	-	-	-	-	Attach chassis bottom cover.
3.	-	-	-	-	-	Install batteries in chassis.
4.	.1 mf	Ant section of gang (green loop lead)	1620 Kc	Fully open	4 (Osc trim)	Adjust for maximum.
5.	-	Radiation loop*	1400 Kc	Tune for maximum	6 (Ant trim)	Adjust for maximum.
6. **	-	Radiation loop*	600 Kc	Tune for maximum	5 (Osc core)	Simultaneously tune gang and adjust core for maximum signal.
7. **	-	Radiation loop*	1620 Kc	Fully open	4 (Osc trim)	Readjust for maximum, if necessary.
8. **	-	Radiation loop*	1400 Kc	Tune for maximum	6 (Ant trim)	Readjust for maximum, if necessary.

*Connect generator output across 5" diameter, 5-turn loop and couple inductively to receiver loop. Keep loops at least 12" apart.

**Steps 6, 7, & 8 need not be performed unless receiver is off calibration or mistracks badly at low frequencies.

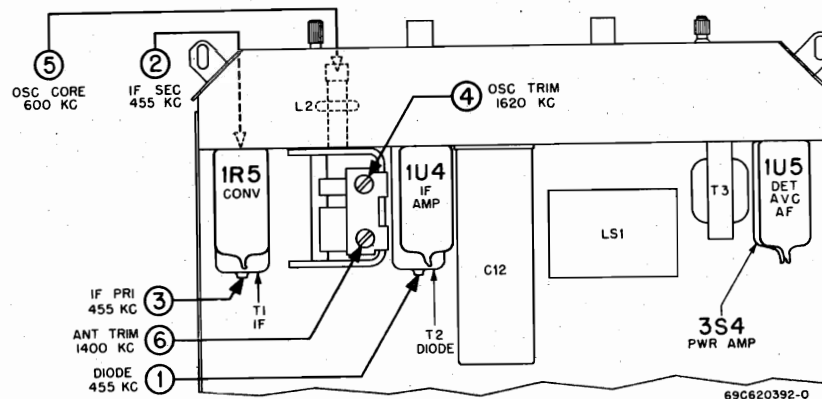

FIGURE 4. TUBE & TRIMMER LOCATIONS

PAGE 23-58 MOTOROLA

**MODELS 52L1, 52L2,
52L3, Ch. HS-327**

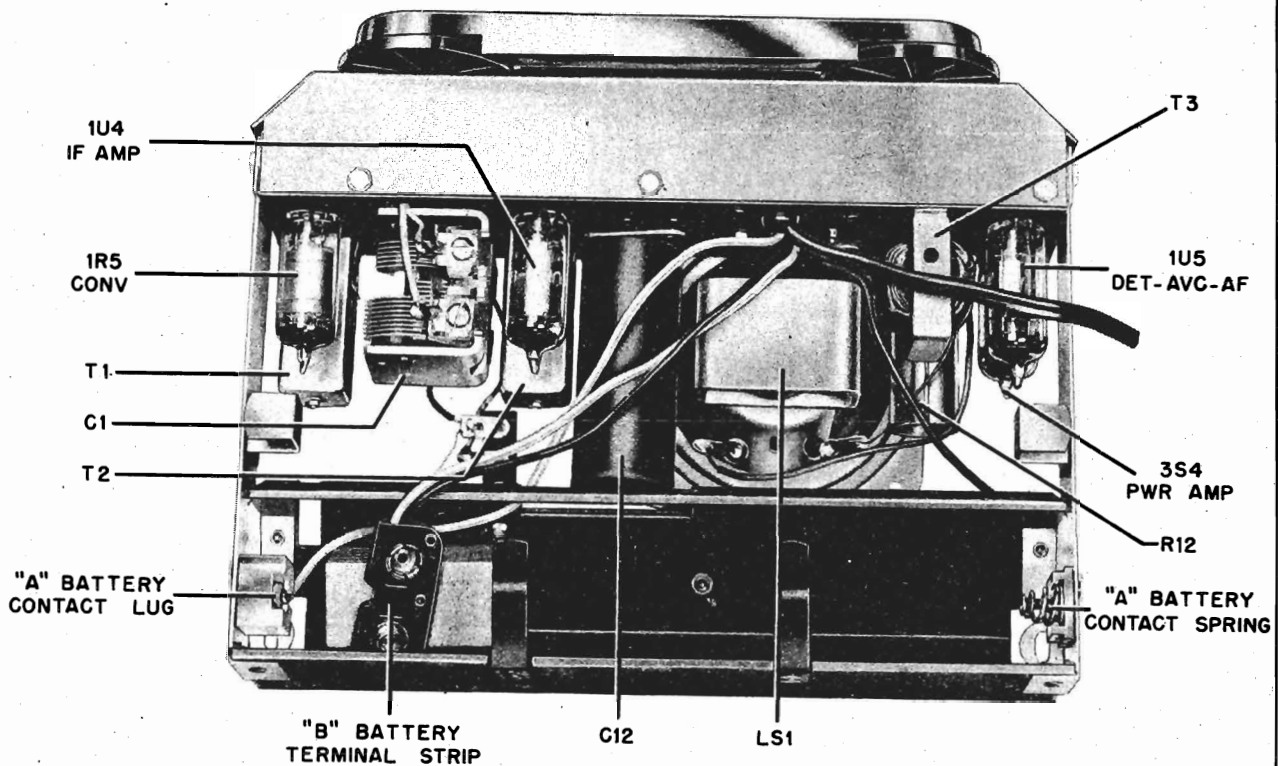
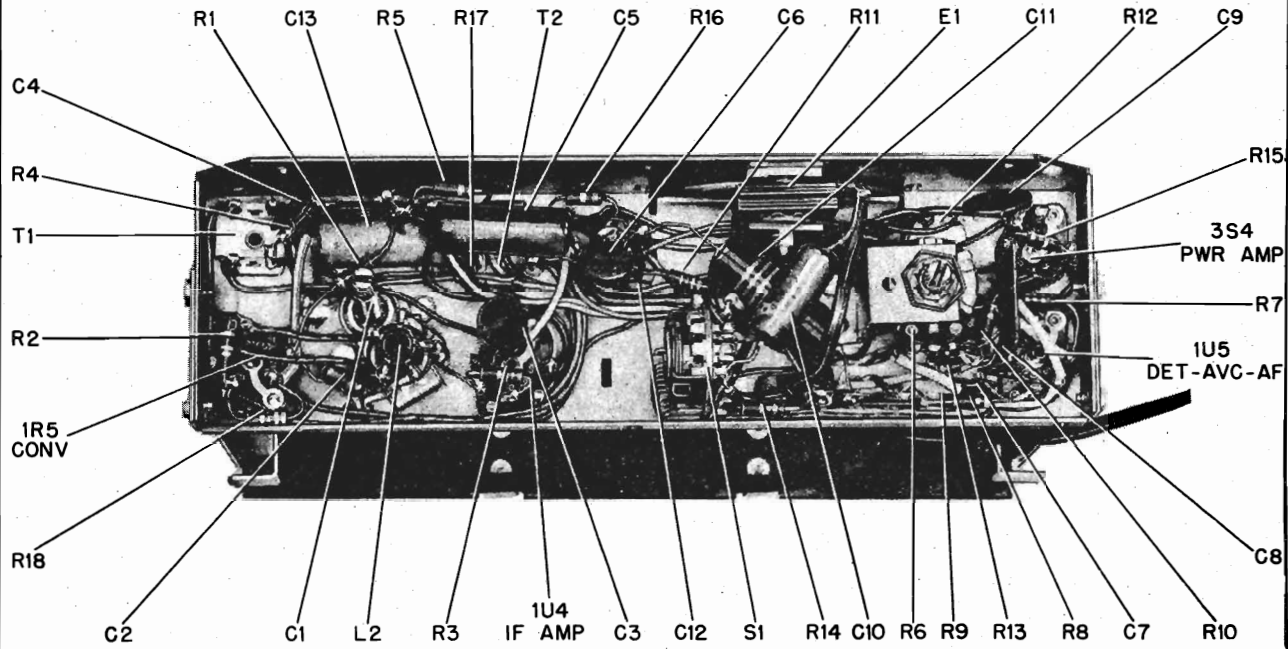

FIGURE 5. PARTS LOCATIONS

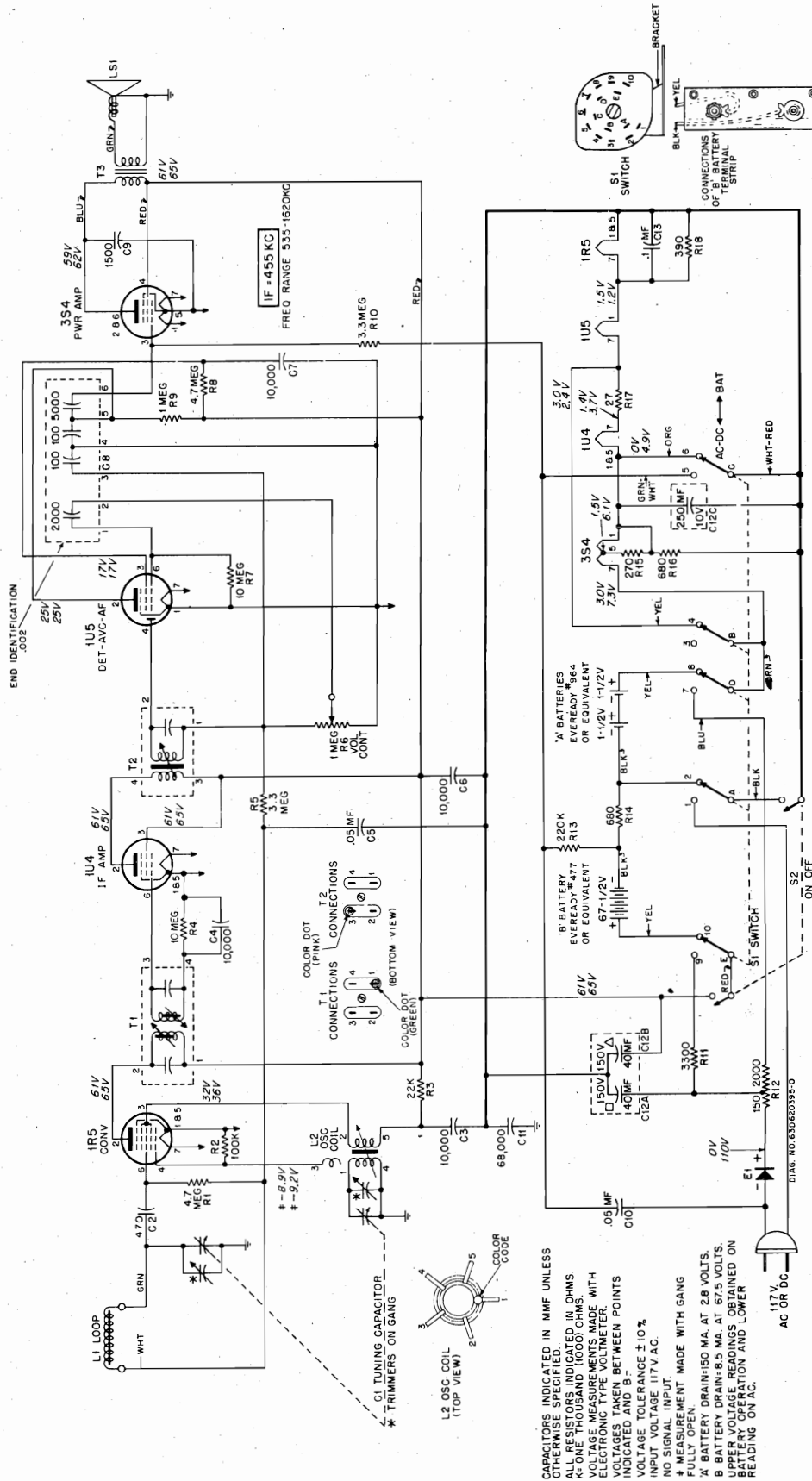

FIGURE 6. SCHEMATIC DIAGRAM

CAPACITORS INDICATED IN MMF UNLESS OTHERWISE SPECIFIED. IN OHMS. K=ONE THOUSAND (1000) OHMS. M=ONE MEG (1,000,000) OHMS. VOLTAGE MEASUREMENTS MADE WITH ELECTRONIC TYPE VOLTMETER. VOLTAGES TAKEN BETWEEN POINTS INDICATED AND B- VOLTAGE TOLERANCE ±10% INPUT VOLTAGE 117V. A.C. NO SIGNAL INPUT. TUNING RANGE FULLY OPEN. 'A' BATTERY DRAIN=50 MA. AT 2.8 VOLTS. 'B' BATTERY DRAIN=8.5 MA. AT 67.5 VOLTS. UPPER VOLTAGE READINGS OBTAINED ON BATTERY OPERATION AND LOWER READING ON A.C.

MODELS 52L1, 52L2,
52L3, Ch. HS-327

PARTS LIST

Ref. No.	Part Number	Description	List Price	Part Number	Description	List Price
CHASSIS PARTS - ELECTRICAL						
Capacitors						
C-1	19B611239	Variable: 2-gang.....	2.65	42B485548	Clip, IF trans mtg.....	.20
C-2	21R115856	Ceramic: 470 mmf 500V.....	.20	42A620155	Clip, spring (holds "A" battery)..	.05
C-3	21R482726	Ceramic, disc: 10,000 mmf 450V	.30	30K611285	Cord, line: with plug; 6 ft long..	.75
C-4	21R482726	Ceramic, disc: 10,000 mmf 450V	.30	9A12705	Insulator, electrolytic mtg....	.30
C-5	8R9861	Paper: .05 mf 400V.....	.30	29R3020	Lug, soldering ("A" battery con- tact).....	.20
C-6	21R482726	Ceramic, disc: 10,000 mmf 450V	.30	2S7051	Nut, hex: Palnut; 3/8-32 x 9/16 (volume control mtg).....	.15
C-7	21R482726	Ceramic, disc: 10,000 mmf 450V	.30	1V620172	Retainer, battery: fibre; complete with brackets; less antenna loop.	1.60
C-8	21K691992	Ceramic, multiple: 2000, 100, 100, 5000 mmf.....	.65	43K692013	Retainer, line cord strain relief bushing (use with 43A692012 bush- ing).....	.05
C-9	21A701029	Ceramic, disc: 1500 mmf 500V	.25	42A620149	Retainer, lug: plastic ("A" bat- tery contact lug mtg).....	.25
C-10	8K471635	Paper: .05 mf 400V.....	.25	42A620150	Retainer, spring: plastic ("A" battery contact spring mtg).....	.25
C-11	8R490234	Molded paper: 68,000 mmf 400V	.30	26A611262	Shield, resistor (over R-12).....	.10
C-12	23B611270	Electrolytic: 40-40 mf/150V, 250 mf/10V.....	2.70	9A690129	Socket, tube: miniature; 7-prong..	.15
C-13	8R9814	Paper: .1 mf 100V.....	.25	2S118403	Speednut: for 3/8" stud (insulating bushing mtg).....	.30
Rectifier						
E-1	48B791092	Rectifier, selenium: half- wave; 65 ma.....	1.40	41K680029	Spring, "A" battery contact....	.20
Coils						
L-1	24B611234	Antenna Loop: with core....	1.00*	31A620153	Strip, "B" battery terminal: with leads.....	.30
L-2	24B611273	Oscillator coil.....	.95			
Speaker						
LS-1	50B611272	Speaker: 3 1/2" PM; 3.2 ohm VC, exch	3.75*	CABINET PARTS		
or	50B620039		2.80	64B611269	Baffle, speaker: fibre.....	.10
Resistors						
Note: All resistors are insulated, carbon type unless otherwise specified.						
R-1	6R2122	4.7 meg 20% 1/2W.....	1.20	1V620730	Cabinet Assembly: green; complete with grille and back cover (52L1)	5.80*
R-2	6R6031	100,000 10% 1/2W.....	1.20	1V620750	Cabinet Assembly: maroon; complete with grille and back cover (52L2)	5.80*
R-3	6R6397	22,000 10% 1/2W.....	1.20	1V620751	Cabinet Assembly: gray; complete with grille and back cover (52L3)	5.80*
R-4	6R2109	10 meg 20% 1/2W.....	1.20	16E611142	Cabinet, front section: green; less grille (52L1).....	1.75
R-5	6R2118	3.3 meg 20% 1/2W.....	1.20	16K611144	Cabinet, front section: maroon; less grille (52L2).....	1.75
R-6	18K611379	Volume control: 1 meg; with switch.....	1.20	16K611146	Cabinet, front section: gray; less grille (52L3).....	1.75
R-7	6R2109	10 meg 20% 1/2W.....	1.20	42A611333	Clip, handle (handle mtg).....	.15
R-8	6R2122	4.7 meg 20% 1/2W.....	1.20	1V611583	Cover Assembly, cabinet back: green; complete with latch spring and stop cord (52L1).....	2.75
R-9	6R6004	1 meg 20% 1/2W.....	1.20	1V611588	Cover Assembly, cabinet back: maroon; complete with latch spring and stop cord (52L2).....	2.75
R-10	6R2118	3.3 meg 20% 1/2W.....	1.20	1V611593	Cover Assembly, cabinet back: gray; complete with latch spring and stop cord (52L3).....	2.75
R-11	6R5581	3300 10% 1/2W.....	1.20	13C611335	Escutcheon, knob (on top of cabinet)	1.15
R-12	17K611149	Wire wound: tapped; 2150 5% 10W.....	1.10	13B611267	Grille, speaker: light green (52L1)	.50
or	17B620181		1.20	13K620046	Grille, speaker: red (52L2).....	.50
R-13	6R6407	220,000 10% 1/2W.....	1.20	13K620047	Grille, speaker: dark green (52L3)	.50
R-14	6R6040	680 10% 1/2W.....	1.20	55B611236	Handle, carrying: green; less clips (52L1 & 52L3).....	.55
R-15	6R6432	270 10% 1/2W.....	1.20	55K611237	Handle, carrying: maroon; less clips (52L2).....	.55
R-16	6R6040	680 10% 1/2W.....	1.20	36K611228	Knob, control: green (52L1 & 52L3)	.20
R-17	6R5683	27 10% 1/2W.....	1.20	36K611229	Knob, control: maroon (52L2).....	.20
R-18	6R5554	390 10% 1/2W.....	1.20	1V611584	Latch spring, back cover: with re- lease button.....	.45
Switch						
S-1	40B611284	Rotary switch, 5PDT (AC/DC, battery selector).....	1.10	3S488092	Screw, machine: 8-32 x 9/16 plain binder head; nickel plated (knob escutcheon mtg).....	.15
Transformers						
T-1	24K600824	IF Transformer: 455 Kc; complete.....	1.35	3S488009	Screw, thread cutting: 6-20 x 3/8 plain hex head; cad pl (chassis mtg).....	.15
T-2	24K620020	Diode Transformer: 455 Kc; complete.....	1.35	2S7089	Speednut: for 3/16" stud (spkr baffle mtg).....	.20
T-3	25B611271	Output Transformer.....	1.50	41A691939	Spring, hinge (back cover hinge).....	.30
CHASSIS PARTS - MECHANICAL						
7A611194	Bracket, volume control mtg.....	.10	NOTE: When ordering parts, specify model number of set in addition to part number and description of part.			
43A611210	Bushing, insulating: threaded (on chassis bottom cover).....	.30				
43A692012	Bushing, line cord strain relief (use with 43K692013 retainer)....	.05				
42K620265	Clamp, antenna loop: plastic (loop mtg).....	.10				
42A620184	Clip, battery contact retainer mtg: spring wire.....per/c	.50				

PRICES SUBJECT TO CHANGE WITHOUT NOTICE

*Plus Federal Excise Tax At Current Rate

MODELS 52CW1, 52CW2,
52CW3, 52CW4, Ch.
HS-329

GENERAL INFORMATION

TYPE - Wall mounted, "Pin-Up" model superheterodyne radio, combined with an electric clock which may be set to automatically turn the radio on.

RECEIVER MODELS - Model	Color
52CW1	Yellow
52CW2	White
52CW3	Green
52CW4	Red

TUNING RANGE - 535 to 1620 Kc IF - 455 Kc

TUBE COMPLEMENT - Type	Function
12BE6	Converter
12BD6	IF Amplifier
12AT6	Det, AVC & AF Amp
50C5	Power Amplifier
35W4	Rectifier

POWER SUPPLY - Operates from 117 volts, 60 cycle, alternating current only.
Power consumption 35 watts.

CLOCK - Sessions self-starting electric clock, with Motorola, face and hands.

MOUNTING

Mount the "Pin-Up" clock radio in a suitable location on the wall with two #10 x 1-1/4" round head wood screws or two 1" long picture hangers (furnished with each new "Pin-Up" clock radio). Use the screws for fastening the clock radio to a wooden wall or into a stud in a plastered wall, and the picture hangers for attaching the set to a plastered or plasterboard wall. The spacing between the two screws or hangers should be 6-7/8", as shown in Figure 2.

OPERATING INSTRUCTIONS

The locations and functions of the clock and radio controls are shown in Figure 1.

NORMAL RADIO OPERATION

Knob "B" on the clock turns the radio on or off. Select stations with the TUNING knob, and adjust volume with the VOLUME control.

A built-in ferrite magnetic iron core antenna eliminates the need for an outside antenna. CAUTION: Never connect the radio chassis to a water pipe, radiator, or other ground.

CLOCK OPERATION

The clock will start as soon as the receiver is plugged into an electrical outlet. To set the hands to the correct time, pull out knob "A" and rotate it in a clockwise direction only.

AUTOMATIC RADIO OPERATION

The clock controls may be pre-set to turn the radio on

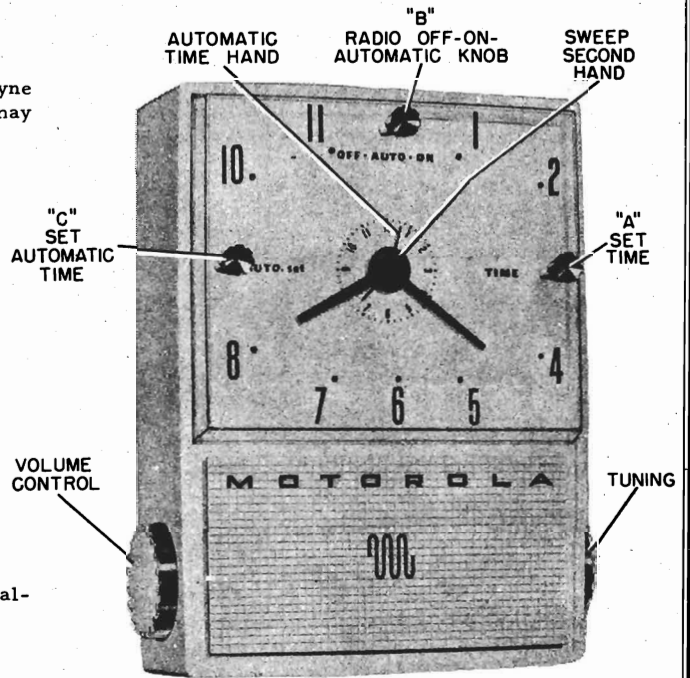

FIGURE 1. FRONT VIEW OF RECEIVER

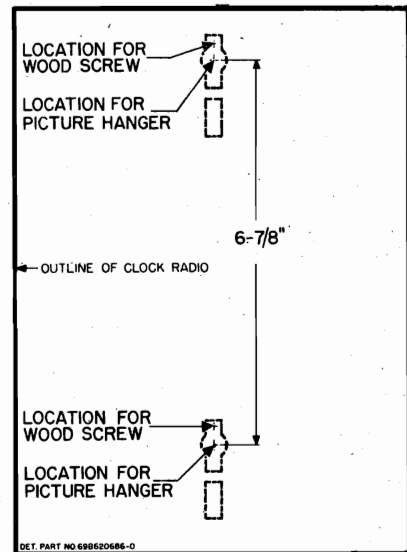

FIGURE 2. MOUNTING LOCATIONS

automatically at any time up to ten hours in advance.

Rotate knob "C" clockwise to the desired time on the automatic time dial scale. Rotate knob "B" to the "AUTO" position. At the pre-set time the radio will begin to play.

If the radio has been turned on automatically and is left unattended, with knob "B" in the "AUTO" position, it will shut off after approximately two hours. To permit continuous operation, rotate knob "B" to the "ON" position.

MODELS 52CW1, 52CW2,
52CW3, 52CW4, Ch. HS-329

SERVICE NOTES

The chassis of this receiver is isolated from the AC power line circuit by a capacitor, to eliminate the shock hazard when handling the receiver. However, as an additional precaution when aligning or servicing the receiver, an isolation transformer should be inserted between the power line and the chassis.

TO REMOVE CHASSIS FOR SERVICE

1. Pull off the two radio control knobs.
2. Remove the four screws from the back cover of the cabinet.
3. Pull off the back cover. See Figure 3.
4. Disconnect the speaker leads.
5. Disconnect the three leads to the clock.

TO REMOVE CLOCK FROM CABINET

1. Remove the radio chassis as above.
2. Pull off the three clock control knobs.
3. Remove the clock dial scale.

4. Remove the three speed nuts which fasten the clock to the cabinet.

5. Remove the clock carefully, to prevent damage to its hands or face.

TO REPLACE CLOCK DIAL BACKGROUND

1. Remove the clock from the cabinet as above.
2. Carefully pull off the four hands.
3. Remove the clock dial background.
4. Install new background.
5. Turn the radio control shaft ("B") to "AUTO" position.
6. Slowly rotate the automatic time set shaft ("C") clockwise until a "click" is heard, indicating that the switch contacts have closed. Do not overshoot this point.
7. Reassemble all four hands in the 12 o'clock position.
8. Check the operation of the clock to be sure the radio turns on at the time indicated on the automatic time dial scale.

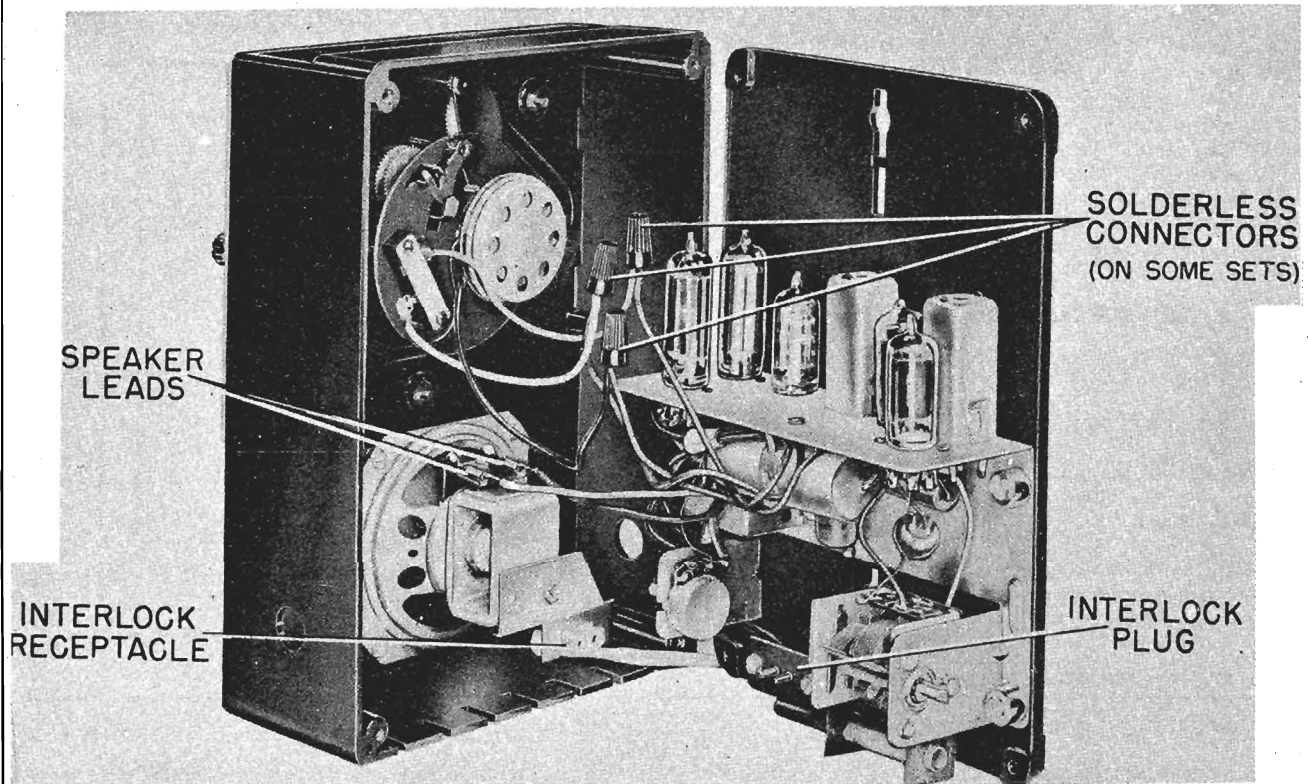

FIGURE 3. BACK COVER REMOVAL

ALIGNMENT

NOTE: It is recommended that an isolation transformer be placed between the power line and the receiver to avoid hum and electrical shocks. If an isolation transformer is not available, connect the low side of the signal generator to B- through a .1 mf capacitor.

1. Connect a low range output meter across the speaker voice coil.
2. Connect the low side of the signal generator to B-.
3. Set the signal generator for 400 cycle, 30% modulation.

4. Turn the receiver volume control to maximum.
5. Use a small fibre screwdriver for aligning the IF and diode transformers.
6. As stages are brought into alignment, reduce the signal generator output to a level which produces less than .40 volts (.05 watt) across the voice coil to avoid overloading the receiver.
7. See Figure 4 for adjustment locations and the following chart for procedure.

ALIGNMENT CHART

STEP	DUMMY ANTENNA	GENERATOR CONNECTION	GENERATOR FREQUENCY	GANG SETTING	ADJUST	REMARKS
IF ALIGNMENT						
1.	.1 mf	Grid of conv. (pin 7, 12BE6)	455 Kc	Fully open	1, 2, 3 & 4 (IF cores)	Adjust for maximum.
RF ALIGNMENT						
2.	.1 mf	Grid of conv. (pin 7, 12BE6)	1620 Kc	Fully open	5 (Osc)	Adjust for maximum.
3.	-	Radiation loop*	1400 Kc	Tune for max	6 (Ant)	Adjust for maximum.

*Connect generator output across 5" diameter, 5 turn loop and couple inductively to receiver loop. Keep generator loop perpendicular to axis of aad at least 12 inches from receiver iron core loop.

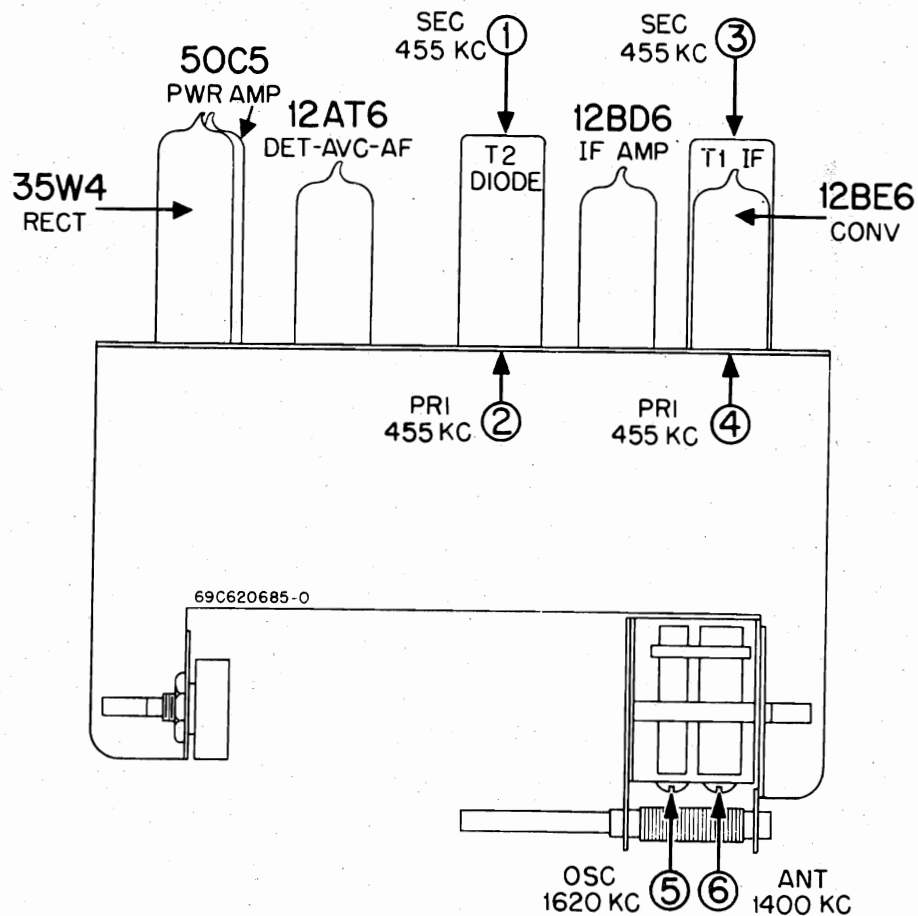

FIGURE 4. TUBE AND ALIGNMENT LOCATIONS

MODELS 52CW1, 52CW2,
52CW3, 52CW4, Ch. HS-329

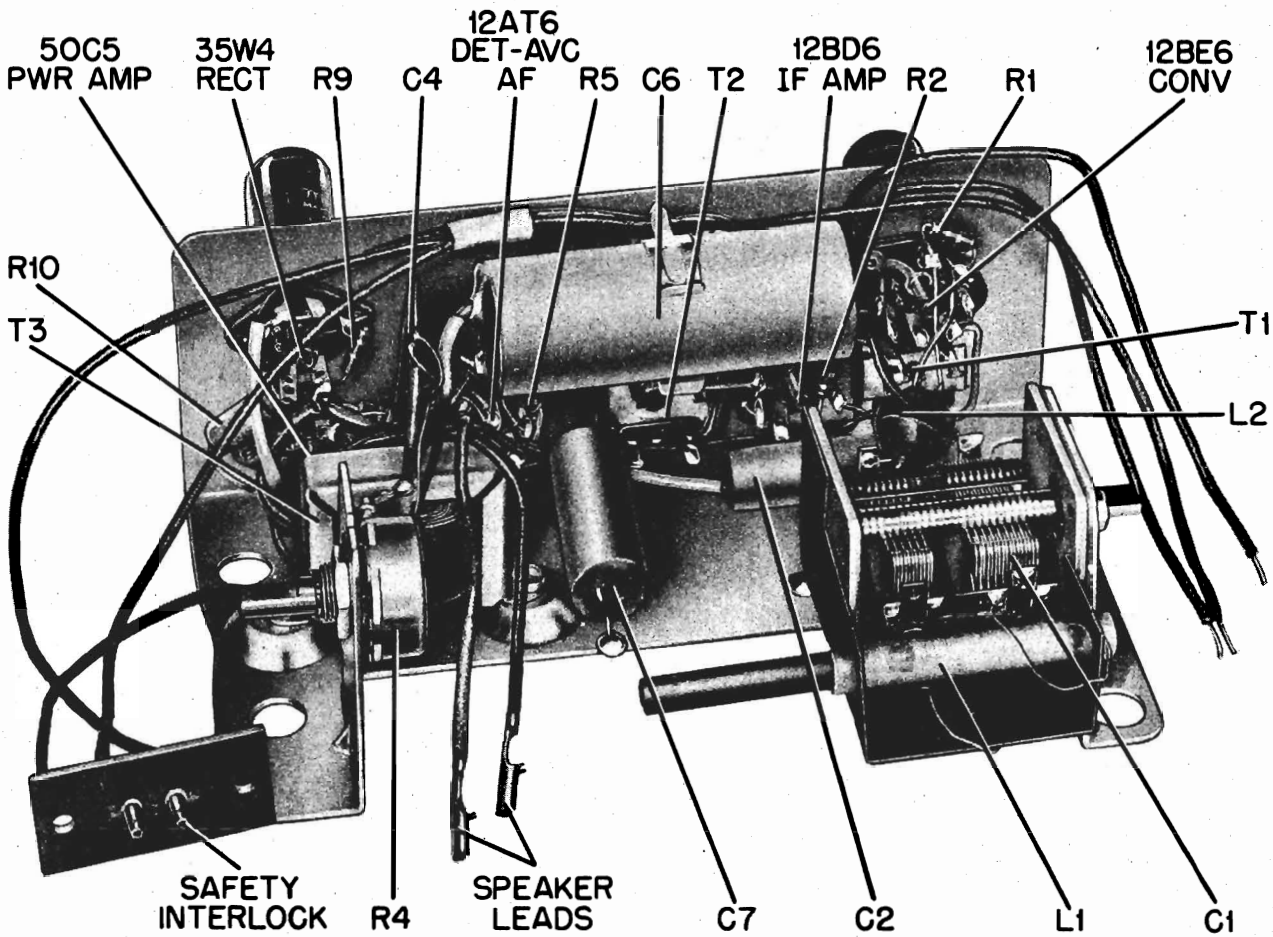
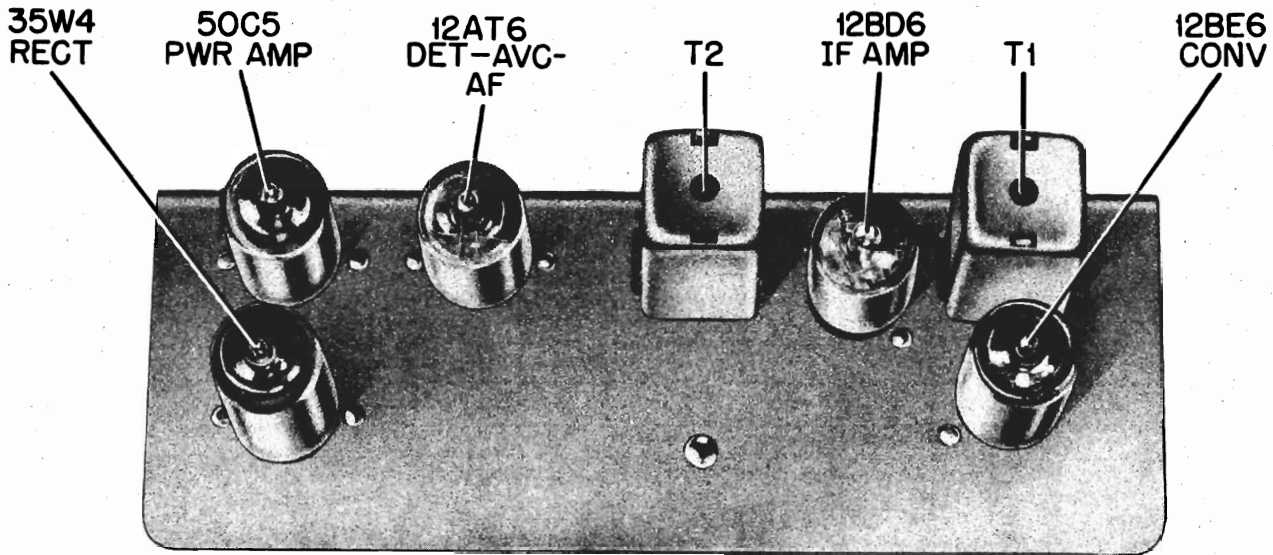

FIGURE 5. PARTS LOCATIONS

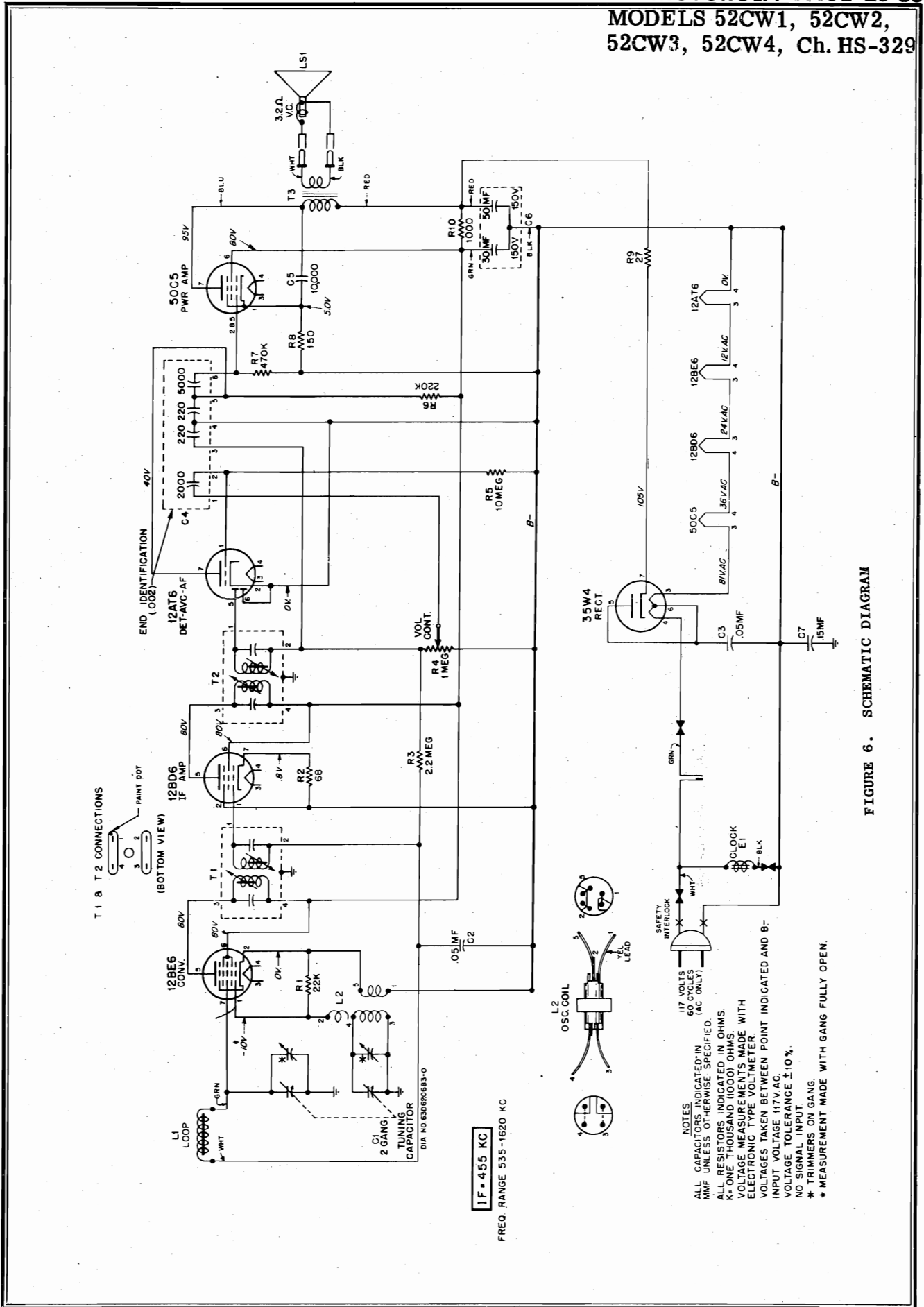

FIGURE 6. SCHEMATIC DIAGRAM

**MODELS 52CW1, 52CW2,
52CW3, 52CW4, Ch. HS-329**

PARTS LIST

NOTE: When ordering parts, specify model number of set in addition to part number and description of part.

Ref. No.	Part Number	Description	List Price	Part Number	Description	List Price
CHASSIS PARTS - ELECTRICAL				CABINET PARTS		
<u>Capacitors</u>				7B620705	Bracket, line cord interlock receptacle mtg. (on spkr).....	.10
C-1	19B620710	Variable: 2-gang.....	2.65	1V621298	Cabinet, wall clock: yellow; with speaker cover, less clock dial scale (52CW1).....	3.55
C-2	8R9821	Paper: .05 mf 200V.....	.25	1V621312	Cabinet, wall clock: white; with speaker cover, less clock dial scale (52CW2).....	3.55
C-3	8R9816	Paper: .05 mf 400V.....	.25	1V621313	Cabinet, wall clock: green; with speaker cover, less clock dial scale (52CW3).....	3.55
C-4	21B482847	Ceramic, multiple: 2000-220-220-5000 mmf/400V.....	.65	1V621314	Cabinet, wall clock: red; with speaker cover, less clock dial scale (52CW4).....	3.55
C-5	21R482726	Ceramic, disc: 10,000 mmf 450V	.30			
C-6	23B600855	Electrolytic: 50-30 mf/150V.	1.60			
C-7	8K72686	Paper: .15 mf 200V.....	.25			
<u>Clock</u>						
E-1	72D620276	Electric Clock Assembly: Sessions; complete, with hands & dial background plate.....	10.25 exch 7.70	28A600064	Connector, wire (clock and radio power leads solderless connector)	.05
<u>Coils</u>				30B620711	Cord, line: with interlock receptacle; less plug; 6 ft long.....	.85
L-1	24K620703	Antenna loop: with core.....	.85	15K620285	Cover, cabinet back: yellow (52CW1)	1.90
L-2	24B680364	Oscillator coil.....	.90	15K620286	Cover, cabinet back: white (52CW2)	1.90
<u>Speaker</u>				15K620287	Cover, cabinet back: green (52CW3)	1.90
LS-1	50B620713	Speaker: 3½" PM; 3.2 ohm VC.	3.75 * exch 2.80	15K620288	Cover, cabinet back: red (52CW4)..	1.90
or	50B620714			15K620289	Cover, speaker: yellow (52CW1)....	1.45
				15K620290	Cover, speaker: white (52CW2).....	1.45
				15K620291	Cover, speaker: green (52CW3)....	1.45
				15K620292	Cover, speaker: red (52CW4).....	1.45
				43A620298	Ferrule, chassis mtg (mounts chassis to back cover).....doz	.15
				42A620709	Hanger, picture: 1" long; with nail (mounts radio to wall).....	.05
<u>Resistors</u>				36B620717	Knob, clock control: black.....	.20
<u>Note:</u> All resistors are insulated carbon type unless otherwise specified.				36C620718	Knob, tuning.....	.50
				36K620297	Knob, volume control.....	.50
				28A620712	Plug, line cord: removable type...	.30
				15K790011	Rivet, shoulder (interlock receptacle mtg).....doz	.35
R-1	6R6028	22,000 20% 1/2W.....doz	1.20	34C620284	Scale, clock dial: plastic.....	1.70
R-2	6R2039	68 10% 1/2W.....doz	1.20	3S488012	Screw, thread-cutting: 6-20 x 1/4 plain hex head; cad pl (spkr mtg).....doz	.15
R-3	6R3927	2.2 meg 20% 1/2W.....doz	1.20	3S115237	Screw, thread-cutting: 6-20 x 5/16 plain hex head; cad pl (line cord interlock plug mtg).....doz	.40
R-4	18A620719	Volume control: 1 meg.....	.80	3S488009	Screw, thread-cutting: 6-20 x 3/8 plain hex head; cad pl (chassis mtg).....doz	.20
R-5	6R2109	10 meg 20% 1/2W.....doz	1.20	3S119885	Screw, thread-cutting: 6-20 x 5/8 Phillips head; cad pl (back cover mtg).....doz	.25
R-6	6R6015	220,000 20% 1/2W.....doz	1.20	3S118636	Screw, wood: #10 x 1-1/4 round head; cad pl (mounts radio to wall).....doz	.25
R-7	6R6032	470,000 20% 1/2W.....doz	1.20	2S476112	Speednut: for .156" stud (clock mtg).....doz	.15
R-8	6R6373	150 10% 1/2W.....doz	1.20	2S400014	Speednut: for 3/8" stud (spkr cover mtg).....	.05
R-9	6R5683	27 10% 1/2W.....doz	1.20			
R-10	6R6327	1000 10% 1W.....	.20			
<u>Transformers</u>						
T-1,2	24C485553	IF and Diode Transformer: 455 Kc; complete.....	1.45			
T-3	25C620715	Output Transformer.....	1.50			
<u>Part Number</u>						
<u>Description</u>						
<u>List Price</u>						
CHASSIS PARTS - MECHANICAL				CLOCK PARTS		
42A75825	Clip, electrolytic mtg.....	.05		<u>Note:</u> The following Motorola parts are for use with Sessions clock movement, Motorola Part No. 72D620276.		
42B485548	Clip, IF trans mtg.....doz	.20		72K620280	Hand, automatic time set: red.....	
5S7805	Eyelet, snap-in (ant insulator mtg).....doz	.15		72K620279	Hand, hour: black.....	
1V620976	Insulator, antenna loop: fibre; with lead.....	.10		72K620278	Hand, minute: black.....	
2S7051	Nut, hex: Palnut; 3/8-32 x 9/16 (volume control mtg).....doz	.15		72K620277	Hand, second: chrome finish.....	
29A620057	Pin, terminal (on spkr leads)..doz	.25		59K621297	Motor, clock (electrical assembly only).....	
28K712319	Plug, line interlock.....	.15		64C620270	Plate, dial background: white.....	
9A690129	Socket, tube: miniature; 7-prong..	.15				

PRICES SUBJECT TO CHANGE WITHOUT NOTICE

*Plus Federal Excise Tax At Current Rate

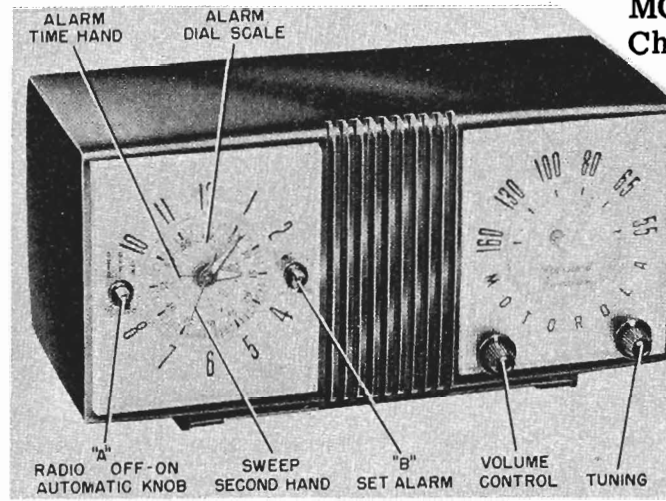

GENERAL INFORMATION

TYPE - AC table model superheterodyne with self-contained electric clock for controlling automatically the operation of the radio.

COLOR - Walnut

TUNING RANGE - 535 to 1620 Kc **IF** - 455 Kc

TUBE COMPLEMENT - Type	Function
12BE6	Converter
12BD6	IF Amplifier
12AT6	Det, AVC & AF Amp
50C5	Power Amplifier
35W4	Rectifier

POWER SUPPLY - Operates from 117 volts, 60 cycle, alternating current only. Power consumption 37 watts.

CLOCK - Telechron self-starting electric clock with Motorola face and hands.

OPERATING INSTRUCTIONS

The locations and functions of the clock and radio controls are shown in the photo above.

NORMAL RADIO OPERATION

Knob "A" on the clock turns the radio on or off. Select stations with the TUNING knob, and adjust volume with the VOLUME control.

A built-in loop antenna eliminates the need for an outside antenna in most locations. When receiving a weak station, rotate the receiver slightly for best signal strength. If additional pick-up is necessary, connect an external antenna to the radio by following the instructions printed on the rear panel. **CAUTION:** Never connect the radio chassis to a water pipe, radiator, or other ground.

CLOCK OPERATION

The clock will start as soon as the receiver is plugged into an electrical outlet. To set the hands to the correct time, rotate the TIME SET knob (on the rear of the radio) in a clockwise direction only.

ALARM OPERATION

To set the alarm, pull out knob "B" and rotate it in a counterclockwise direction to the desired time on the alarm dial scale. The alarm will ring for one hour, or until knob "B" is pushed in. The alarm function is completely independent of the other controls on the clock.

AUTOMATIC RADIO OPERATION

The clock controls may be pre-set to turn the radio on automatically at any time up to twelve hours in advance.

Pull out knob "B"; rotate it counterclockwise to the desired time on the alarm dial scale, and push the knob back in. Rotate knob "A" first to the "OFF" position and then to the "AUTO" position. At the pre-set time, the radio will come on and will continue to play until turned off manually. The alarm will ring also if the knob "B" is left pulled out. The radio will come on first and, after an interval of about ten minutes, the alarm will ring.

MODELS 52C1, 52C1A,
Ch. HS-309

ALIGNMENT

NOTE: It is recommended that an isolation transformer be placed between the power line and the receiver to avoid hum and electrical shocks. If an isolation transformer is not available, connect the low side of the signal generator to chassis through a .1 mf capacitor.

1. Connect a low range output meter across the speaker voice coil.
2. Connect the low side of the signal generator to chassis.
3. Set the signal generator for 400 cycle, 30% modulation.

4. Turn the receiver volume control to maximum.

5. Use a small fibre screwdriver for aligning the IF and diode transformers.

6. As stages are brought into alignment, reduce the signal generator output to a level which produces less than .40 volts (.05 watts) across the voice coil to avoid overloading the receiver.

7. See Figure 1 for adjustment locations and the following chart for procedure.

ALIGNMENT CHART

STEP	DUMMY ANTENNA	GENERATOR CONNECTION	GENERATOR FREQUENCY	GANG SETTING	ADJUST	REMARKS
IF ALIGNMENT						
1.	.1 mf	Grid of conv. (pin 7, 12BE6)	455 Kc	Fully open	1, 2, 3 & 4 (IF cores)	Adjust for maximum.
RF ALIGNMENT						
2.	-	-	-	Fully closed	-	Set pointer to horizontal position.
3.	.1 mf	Grid of conv. (pin 7, 12BE6)	1620 Kc	Fully open	5 (osc)	Adjust for maximum.
4.	-	Radiation loop*	1400 Kc	Tune for max	6 (Ant)	Adjust for maximum.

*Connect generator output across 5" diameter, 5 turn loop and couple inductively to receiver loop. Keep loops at least 12" apart.

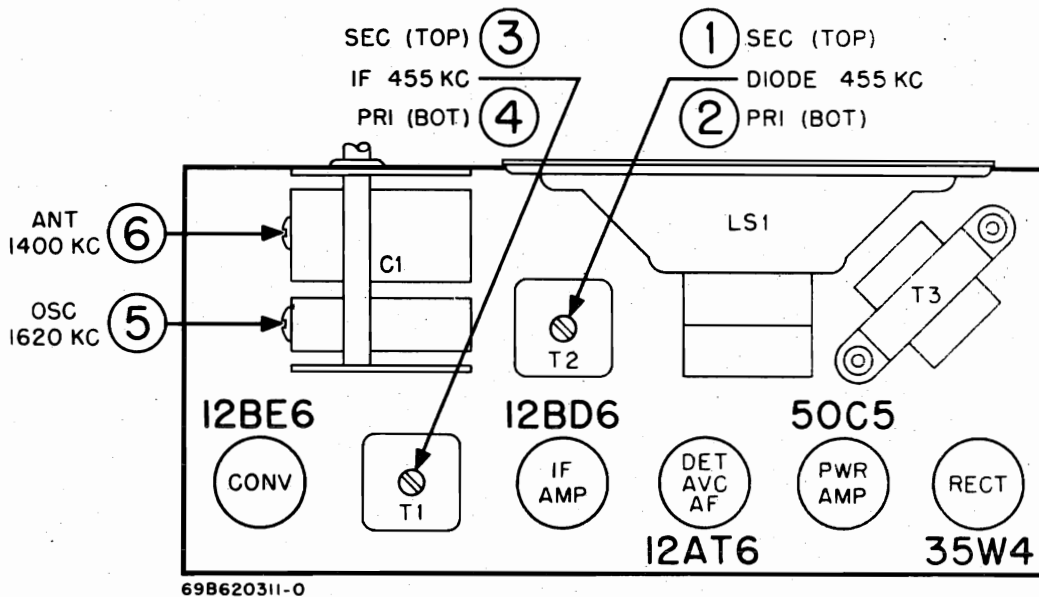

FIGURE 1. TUBE AND TRIMMER LOCATION

SERVICE NOTES

The chassis of this receiver is connected directly to the power line. When operating the chassis outside of its cabinet, use an isolation transformer between the power line and the receiver to reduce the possibility of an electrical shock.

TO REMOVE RADIO CHASSIS FROM CABINET

1. Pull off the two radio control knobs.
2. Remove the three hex head screws which hold the loop to the cabinet.
3. From the back of the cabinet, remove the two hex head screws at the rear edge of the radio chassis.
4. Slide the radio chassis and loop from the cabinet.
5. Disconnect the power leads to the radio chassis.

TO REMOVE CLOCK FROM CABINET

1. Remove the radio chassis as above.
2. Pull off the two clock control knobs.
3. From the back of the cabinet, remove the three hex head screws which hold the clock and its fibre insulator.
4. Carefully remove the clock, to prevent damage to its hands or face.

TO REPLACE CLOCK DIAL BACKGROUND

1. Remove the clock from the cabinet as above.
2. Carefully pull off the three hands.
3. Remove the alarm dial and dial background.

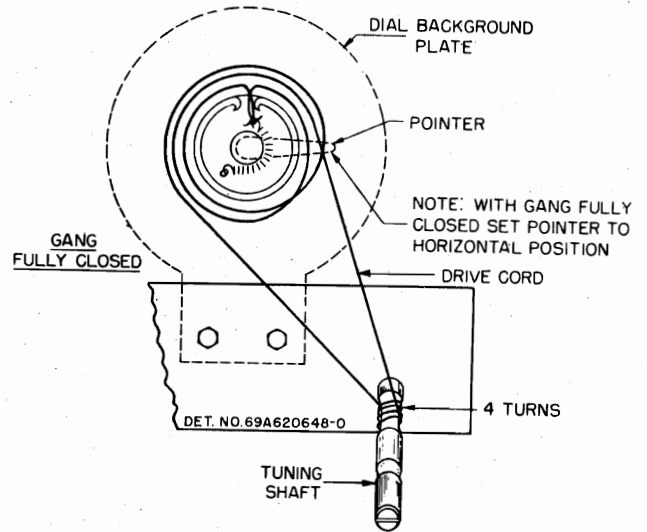

FIGURE 2. STRING DRIVE DETAIL

4. Install new background.
5. Turn the radio control shaft to "AUTO" position.
6. Slowly rotate the time set shaft clockwise until the switch contacts behind the radio control shaft close.
7. Reassemble the alarm dial and three hands. Set all the hands to indicate 12 o'clock. Set the figure "12" on the alarm dial to index with the small pointer on the hour hand.
8. Check the automatic operation to be sure the switch contacts close at the time indicated on the alarm dial.

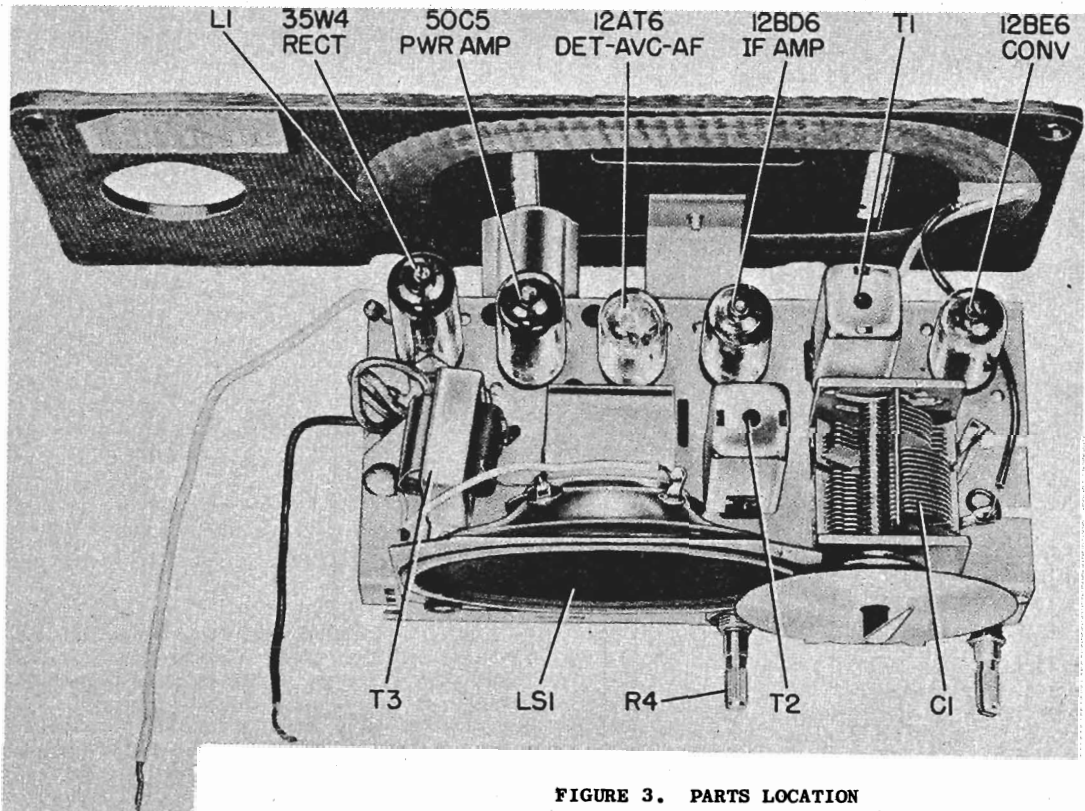
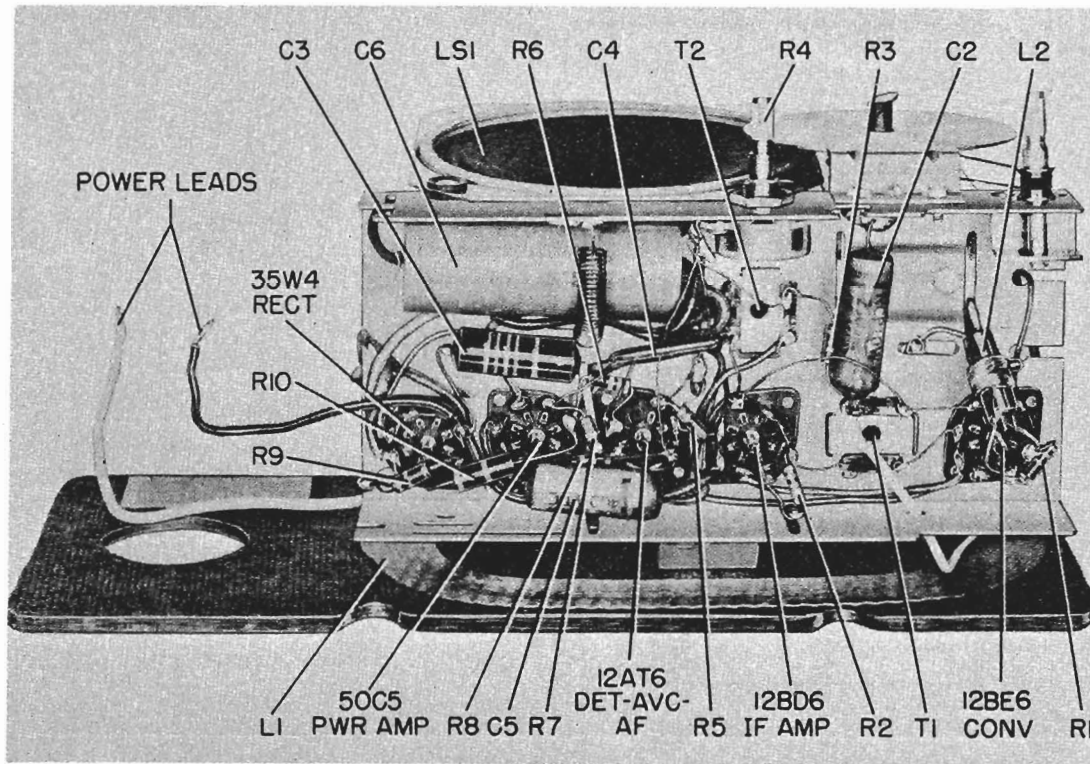

FIGURE 3. PARTS LOCATION

MODELS 52C1, 52C1A,
Ch. HS-309



PARTS LIST

NOTE: When ordering parts, specify model number of set in addition to part number and description of part.

Ref. No.	Part Number	Description	List Price	Resistors				
CHASSIS PARTS - ELECTRICAL				Note: All resistors are insulated carbon type unless otherwise specified.				
Capacitors				R-1	6R6028	22,000	20%	1/2W.....doz 1.20
C-1	19B610820	Variable: 2-gang; with pulley	2.85	R-2	6R6018	100	20%	1/2W.....doz 1.20
C-2	8R9821	Paper: .05 mf 200V.....	.20	R-3	6R3927	2.2 meg	20%	1/2W.....doz 1.20
C-3	8R490232	Molded paper: 47,000 mmf 400V	.30	R-4	18A600018	Volume control: 1 meg.....		.80
C-4	21B482847	Ceramic, multiple: 2000-220-220-5000 mmf/400V.....	.65	R-5	6R2109	10 meg	20%	1/2W.....doz 1.20
C-5	8R9802	Paper: .02 mf 400V.....	.20	R-6	6R6032	470,000	20%	1/2W.....doz 1.20
C-6	23B600855	Electrolytic: 50-30 mf/150V.	1.10	R-7	6R6032	470,000	20%	1/2W.....doz 1.20
Clock				R-8	6R3992	150	20%	1/2W.....doz 1.20
E-1	59D610825	Electric Clock Assembly: Telechron; with hands; less line cord.....	10.25	R-9	6R5683	27	10%	1/2W.....doz 1.20
				R-10	6R3953	1000	20%	1W.....doz .20
				Transformers				
				T-1,2	24C485553	IF and diode transformer: 455 Kc; complete.....		.95
				T-3	25B478121	Output transformer.....		1.05
Coils				CHASSIS PARTS - MECHANICAL				
L-1	24K610788	Antenna Loop & Panel Assembly	1.10*	7A478118	Bracket, loop mtg.....			.05
L-2	24A478129	Oscillator coil.....	.90	7A77337	Bracket, tuning shaft.....			.05
Speaker				42B485548	Clip, IF trans mtg.....doz			.20
LS-1	50K610558 or			5A484268	Grommet, speaker mtg: rubber...doz			.20
	50C600017 or			14A478119	Insulator, loop brkt mtg: fiber.....doz			.15
	50C600857 or			2S7051	Nut, hex palnut: 3/8-32 x 9/16 (volume control mtg).....doz			.15
	50C610506 or			35A601669	Pad, cushion: sponge rubber (spkr cushion).....			.10
	50B610052 or							
	50K610557	Speaker: 4" PM; 3.2 ohm VC..	3.90*					
		exch	2.95					

MODELS 52C1, 52C1A,
Ch. HS-309

Part Number	Description	List Price
CLOCK PARTS		
64B610782	Plate, radio dial background: silver color.....	.55
52A610809	Pointer, radio dial: light green..	.25
1A610808	Shaft, tuning: with pulley.....	.15
9B472534	Socket, tube: miniature; 7-prong..	.15
41A73996	Spring, tension (electrolytic mtg)	.05
41A73619	Spring, tension (gang drive cord).....doz	.40
4A70015	Washer, "C" (tuning shaft mtg).....per/c	.50
14A11493	Washer, shoulder: fibre (loop bracket mtg).....doz	.35
CABINET PARTS		
1X610824	Cabinet, table model: walnut; less overlays and clock and radio scales.....	4.75*
28A600064	Connector, wire (connects clock & radio power leads).....	.05
14B611368	Insulator, clock: fibre (over back of clock).....	.15
36B610817	Knob, clock control: black.....	.20
36B610815	Knob, radio control: black.....	.20
13A610802	Overlay, clock background: gold color.....	.15
13A610804	Overlay, radio background: gold color.....	.20
34K610822	Scale, clock dial: plastic.....	1.45
34C610791	Scale, radio dial: plastic.....	1.50

Note: The following Motorola parts are for use with Telechron clock movement Part No. 59D610825.

34K610826	Alarm Dial: silver color.....	.40
42A470832	Clamp, line cord.....	.10
30K478137	Cord, line: with plug; 6 ft long..	.55
64K620049	Dial background: silver color.....	.40
52K610827	Hand, hour: green.....	.15
52K610828	Hand, minute: green.....	.15
52K610829	Hand, second: black.....	.15
36K601002	Knob, time set.....	.25
59K610568	Motor, clock (rotor assembly only)	3.40

PRICES SUBJECT TO CHANGE WITHOUT NOTICE

*Plus Federal Excise Tax At Current Rate

S U P P L E M E N T N O . 1

GENERAL INFORMATION

Model 52C1A is the same as Model 52C1 except for styling. A complete listing of 52C1A cabinet parts is given below.

Refer to HS-309 Service Manual for service instructions, chassis replacement parts, and clock replacement parts.

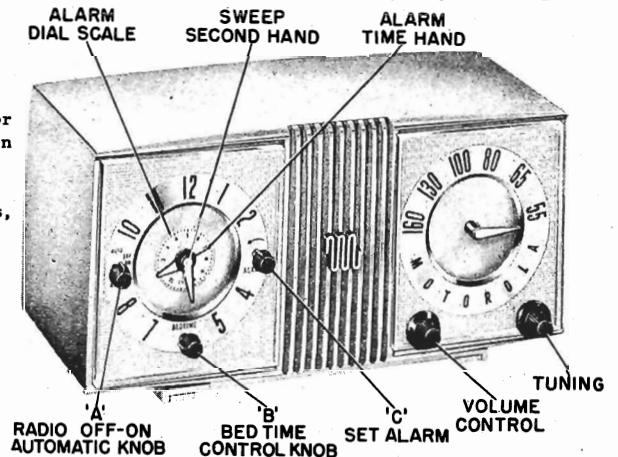

PARTS LIST SUPPLEMENT

NOTE: When ordering parts, specify model and chassis number of set in addition to part number and description of part. The following parts are revisions of or additions to the original items listed in the HS-309 Service Manual.

Part Number	Description	List Price
CABINET PARTS		
1V622095	Cabinet, table model: walnut; with medallion; less overlays.....	5.85*
61K621891	Crystal, plastic (clock face cover)	.85
61K621529	Crystal, plastic (radio face cover)	.85
64K621523	Dial background.....	.45
59K621787	Electric Clock Assembly: Telechron; with hands; less line cord.....	10.25 exch 7.70
36K621520	Knob, clock control (black).....	.20
13A792195	Medallion, on speaker grille.....	.55
13K621892	Overlay, clock background: with numbers.....	.95
13C621527	Overlay, radio background: with numbers.....	.95
43A600095	Sleeve, paper (on pointer shaft).....per/c	.50
2S490840	Speednut, medallion mtg.....doz	.15

PRICES SUBJECT TO CHANGE WITHOUT NOTICE

*Plus Federal Excise Tax At Current Rate

GENERAL INFORMATION

TYPE - AC table model, superheterodyne with appliance outlet and self-contained electric clock for automatically controlling the operation of the radio and the outlet.

RECEIVER MODELS - Model	Color
53C6	Walnut
53C7	Ivory
53C8	Green
53C9	Tan

TUNING RANGE - 535 to 1620 Kc IF - 455 Kc

TUBE COMPLEMENT - Type	Function
12BE6	Converter
12BA6	IF Amplifier
12AT6	Det, AVC & AF Amp
50C5	Power Amplifier
35W4	Rectifier

POWER SUPPLY - Operates from 117 volts, 60 cycle, alternating current only. Power consumption 37 watts.

OPERATING INSTRUCTIONS

The locations and functions of the clock and radio controls are shown in the photo above.

NORMAL RADIO OPERATION

The **OPERATION SELECTOR** knob on the clock turns the radio on or off. Select stations with the **TUNING** knob, and adjust volume with the **VOLUME** control.

A built-in loop antenna eliminates the need for an outside antenna in most locations. When receiving a weak station, rotate the receiver slightly for best signal strength. If additional pick-up is necessary, connect an external antenna to the radio by winding the antenna lead-in around the tongue on the rear panel. (This couples external antenna capacitively to loop.) **CAUTION:** Never connect the radio chassis to a water pipe, radiator, or other ground.

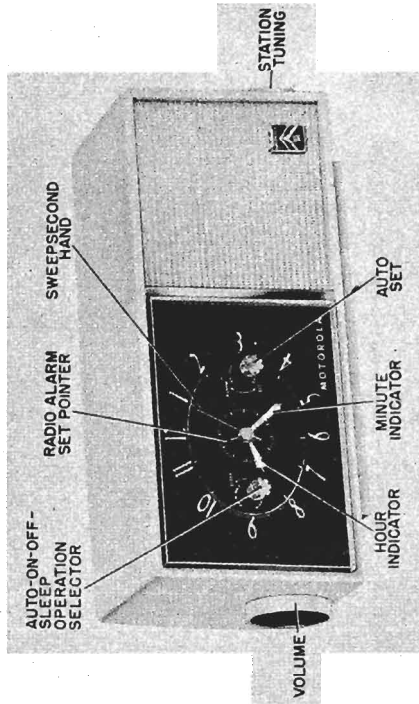

APPLIANCE OUTLET - For use with 117 volt AC appliances only, rated at 1100 watts or less.

CLOCK - Telechron self-starting electric clock, with Motorola face and hands.

CLOCK OPERATION

The clock will start as soon as the receiver is plugged into an electrical outlet. To set the hands to the correct time, rotate the **TIME SET** knob (on the rear of the radio) in a clockwise direction only.

ALARM OPERATION

To set the alarm, pull out **AUTO SET** knob and rotate it in a counterclockwise direction to the desired time on the alarm dial scale. The alarm will ring for one hour, or until **AUTO SET** knob is pushed in. The alarm function is completely independent of the other controls on the clock.

SLEEP CONTROL

The **SLEEP** control will turn the radio and appliance off after any pre-set interval of time up to one hour.

MODELS 53C6, 53C7,
53C8, 53C9, Ch. HS-338

TO SET SLEEP CONTROL

Turn OPERATION SELECTOR knob counterclockwise. The farther the control is turned, the longer the radio will play, up to a maximum of 60 minutes.

AUTOMATIC RADIO OPERATION

The clock controls may be pre-set to turn the radio on automatically at any time up to twelve hours in advance.

If an appliance is plugged into the receptacle on the rear of the receiver, it will be turned on automatically along with the radio.

TO SET RECEIVER FOR AUTOMATIC OPERATION:

1. Turn OPERATION SELECTOR knob to ON. Allow a short period of time for tube warm-up.
2. Set the radio dial to the station you would like to hear at any pre-determined time, up to twelve hours in advance, and adjust volume to desired loudness.
3. Pull out and turn AUTO SET knob until RADIO ALARM SET POINTER indicates time radio is to be turned on automatically.
4. Turn OPERATION SELECTOR to OFF and then pull OPERATION SELECTOR out for AUTO. Leave in AUTO position.
5. The radio is now set to turn on automatically at the time indicated by RADIO ALARM SET POINTER. The radio will turn on at the pre-set time and will continue to play until

OPERATION SELECTOR is pushed in and located in the OFF position.

SLEEP CONTROL AND AUTOMATIC OPERATIONS
COMBINED

By combining the sleep control and automatic radio operation, it is possible to turn the radio off automatically and to turn it on again automatically.

TO USE THIS FEATURE, SET CONTROLS AS FOLLOWS:

1. Pull out and turn AUTO SET knob until RADIO ALARM SET POINTER indicates time radio is to be turned on automatically; push knob back in (if you wish alarm to ring, leave AUTO SET knob pulled out).
2. Turn OPERATION SELECTOR to OFF and then pull OPERATION SELECTOR out for AUTO.
3. Turn OPERATION SELECTOR counterclockwise for SLEEP CONTROL.
4. Tune in desired station and adjust volume.

APPLIANCE OUTLET

To control an electrical appliance automatically, plug it into the receptacle on the back of the radio. It will then be turned on or off simultaneously with the radio.

CAUTION: Note that the rating of the outlet is 1100 watts or less.

If radio reception is not desired when operating the appliance, rotate the radio volume control to the minimum volume position.

SERVICE NOTES

TO REMOVE RADIO CHASSIS FROM CABINET

1. Pull off the two radio control knobs.
2. Remove the four hex head screws which hold the loop to the cabinet, disconnect leads, and remove loop.
3. From the back of the cabinet, remove the two hex head screws at the rear edge of the radio chassis.
4. Disconnect clock plug from radio chassis.
5. Slide the radio chassis from the cabinet.
6. To service chassis when clock is disconnected, connect jumper wire between pins 3 & 4 of clock receptacle on chassis to complete power circuit.

necessary to re-synchronize them with the alarm dial, as outlined below:

1. Pull out the OPERATIONSELECTOR knob to the "AUTO" position.
2. Slowly rotate the time set knob clockwise (as viewed from rear) until the clock switch contacts close. This is indicated by an audible click, or an ohmmeter connected to pins 3 & 4 of the clock plug, can be used as a visual indicator.
3. Set all the hands to indicate 12 o'clock.
4. Check the automatic operation to be sure the switch contacts close at the time indicated on the alarm dial.

TO REMOVE CLOCK FROM CABINET

1. Remove radio chassis from cabinet as described above.
2. Remove clock control knobs. They pull off.
3. Carefully pry off the plastic crystal.
4. Lift off the clock background overlay.
5. From the inside of cabinet, remove two nuts that mount clock.
6. Carefully remove clock from cabinet.

CLOCK REPAIR INFORMATION

Telechron timers can be repaired at Authorized Telechron Service Stations or at the Product Service Department, Ashland, Mass. Consult your Motorola Distributor for the name of the nearest Telechron Service Station, or refer to the classified section of the telephone directory in large cities.

The timer should be removed from the radio cabinet and packed carefully in order that no further damage results during shipment.

An acknowledgement with a quotation and a request for payment will be sent to the dealer before the repair is made. The timer will be returned to the dealer on receipt of payment. If the timer is within warranty, repairs will be made on a no-charge basis.

TO SYNCHRONIZE HANDS AND ALARM

If the hands have been moved accidentally, it will be

ALIGNMENT

MODELS 53C6, 53C7,
53C8, 53C9, Ch. HS-338

NOTE: Use an isolation transformer placed between the power line and the receiver to avoid hum and electrical shocks. If an isolation transformer is not available, connect the low side of the signal generator to B- through a .1 mf capacitor.

1. Connect a low range output meter across speaker voice coil.
2. Connect the low side of the signal generator through a .1 mf capacitor to B-
3. Set the signal generator for 400 cycle, 30% modulation.
4. Turn the receiver volume control to maximum.
5. Use a small fibre screwdriver for aligning the IF and diode transformers.
6. As stages are brought into alignment, reduce the signal generator output to a level which produces less than .40 volts (.05 watt) across the voice coil to avoid overloading the receiver.
7. See Figure 1 for adjustment locations and the following chart for procedure.

ALIGNMENT CHART

STEP	DUMMY ANTENNA	GENERATOR CONNECTION	GENERATOR FREQUENCY	GANG SETTING	ADJUST (SEE FIG. 1)	REMARKS
IF ALIGNMENT						
1.	.1 mf	Grid of conv. (pin 7, 12BE6)	455 Kc	Fully open	1, 2, 3 & 4 (IF cores)	Adjust for maximum.
RF ALIGNMENT						
2.	.1 mf	Grid of conv. (pin 7, 12BE6)	1620 Kc	Fully open	5 (Osc)	Adjust for maximum.
3.	-	Radiation loop*	1400 Kc	Tune for max	6 (Ant)	Adjust for maximum.

*Connect generator output across 5" diameter, 5 turn loop and couple inductively to receiver loop. Keep loops at least 12" apart.

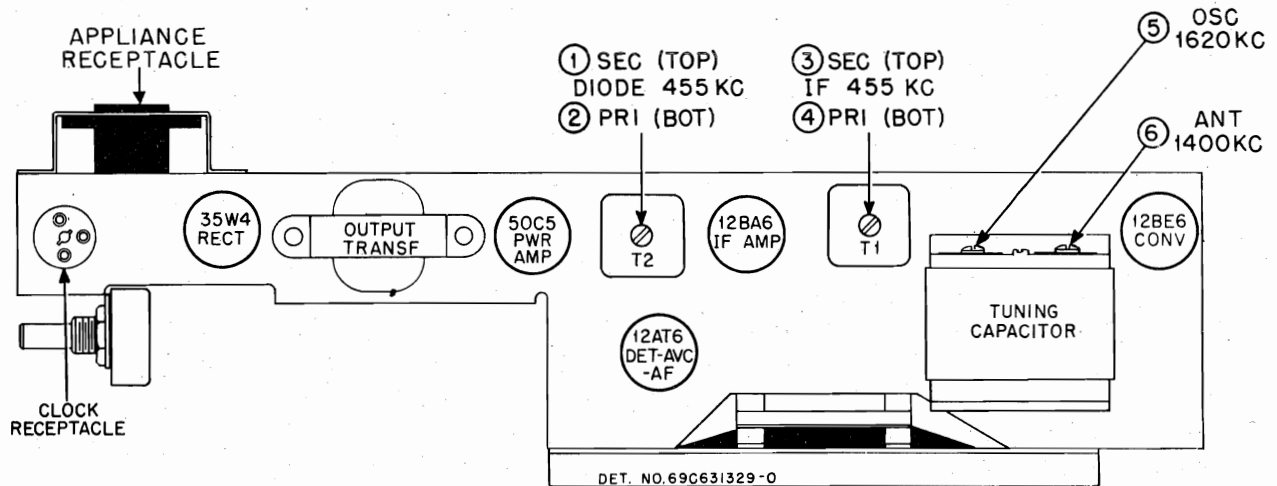

FIGURE 1. TUBE & TRIMMER LOCATIONS

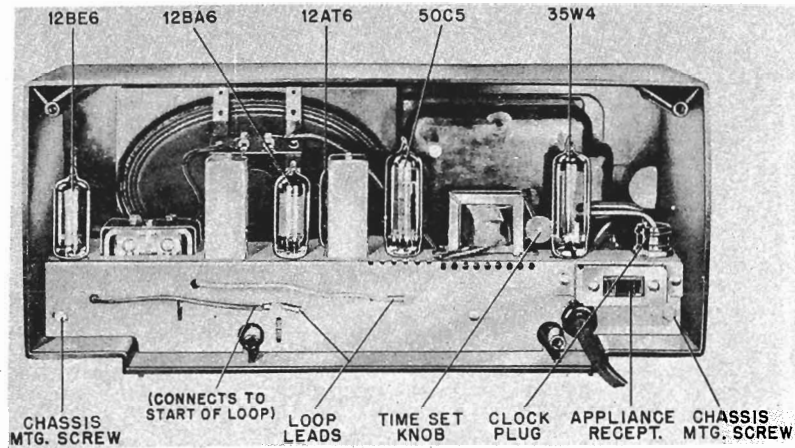

FIGURE 2. REAR VIEW OF SET

MODELS 53C6, 53C7,
53C8, 53C9, Ch. HS-338

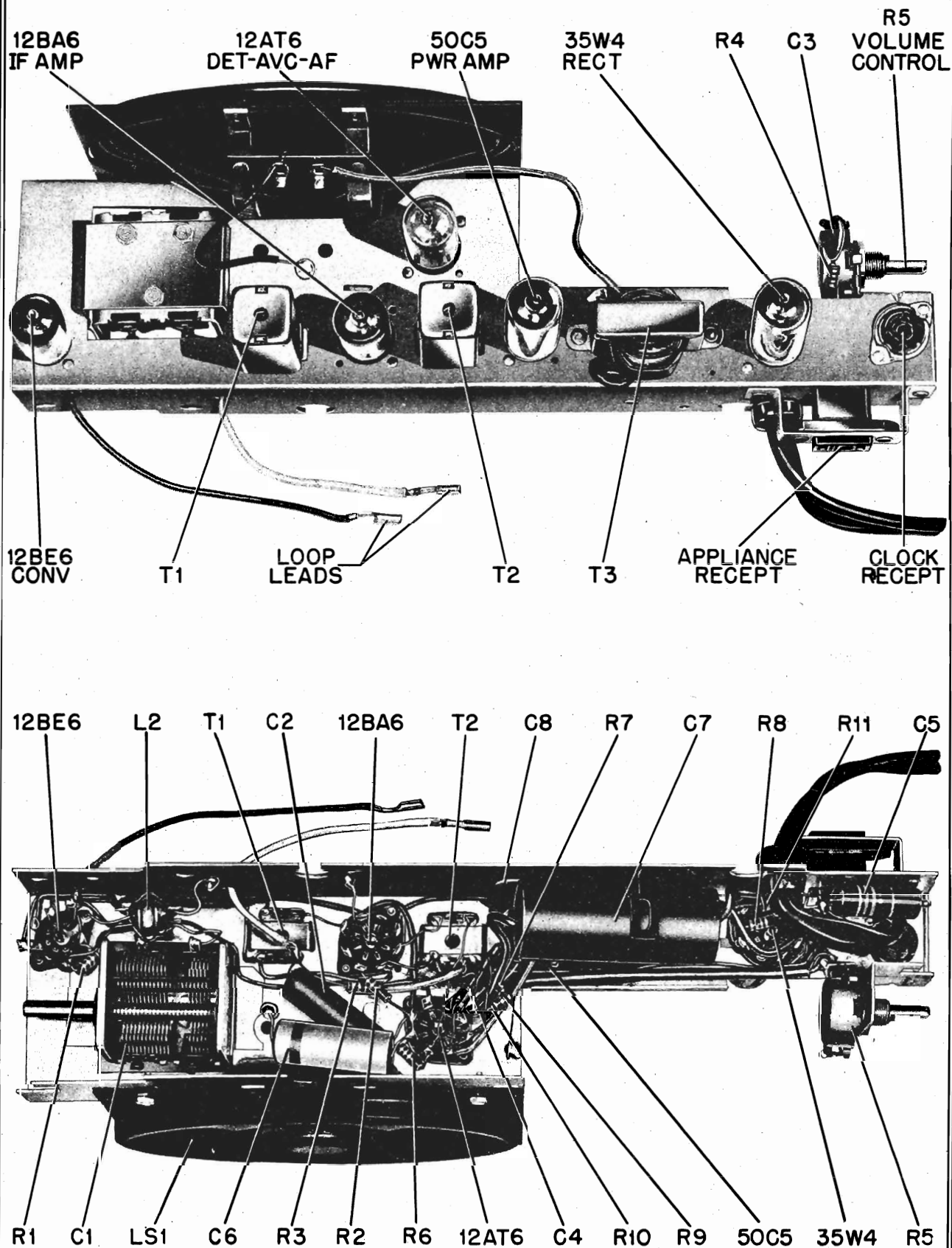

FIGURE 3. PARTS LOCATIONS

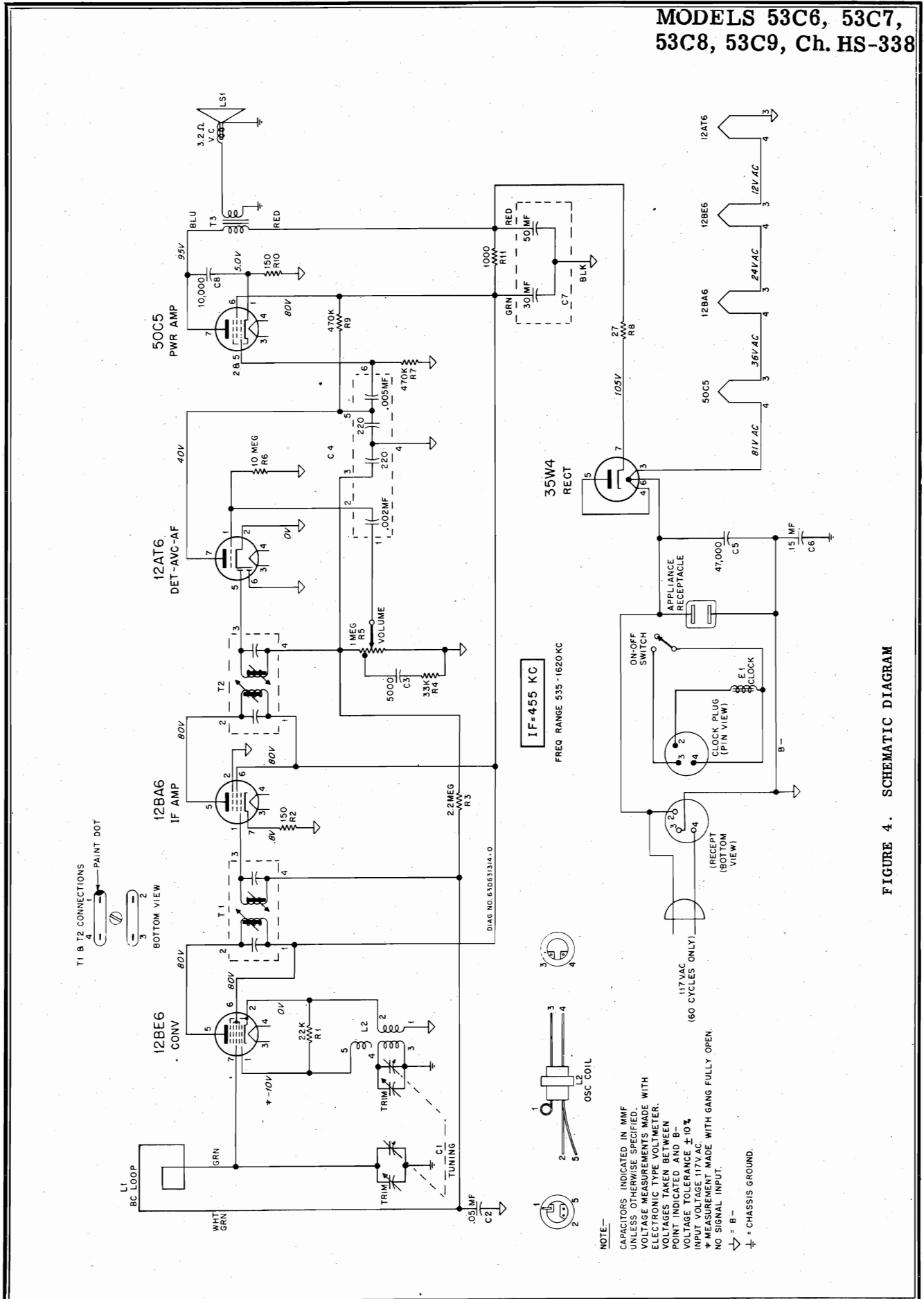

FIGURE 4. SCHEMATIC DIAGRAM

MODELS 53C6, 53C7,
53C8, 53C9, Ch.
HS-338

PARTS LIST

NOTE: When ordering parts, specify model number of set in addition to part number and description of part.

Ref. No.	Part Number	Description	List Price	Part Number	Description	List Price
CHASSIS PARTS - ELECTRICAL				CHASSIS PARTS - MECHANICAL		
<u>Capacitors</u>						
C-1	19B630712	Variable: 2-gang.....	2.45	43K610736	Bushing, line cord strain relief (use with 43K610737 retainer)....	.20
C-2	8R9821	Paper: .05 mf 200V.....	.25	42B485548	Clip, IF transformer mtg.....doz	.35
C-3	21R115312	Ceramic; disc: 5000 mmf 450V	.25	42A75825	Clip, electrolytic mtg.....	.05
C-4	21B482847	Ceramic, multiple: 2000, 220, 220, 5000 mmf/400V.....	.65	30K620856	Cord, line: with plug	1.00
C-5	8K490232	Molded paper: 47,000 mmf 400V	.30	2S7051	Nut, hex: Palnut; 3/8-32 x 9/16 (vol control mtg).....doz	.15
C-6	8R9843	Paper: .15 mf 200V.....	.20	9A721182	Receptacle, appliance.....	.30
C-7	23K722536	Electrolytic: 50-30 mf/150V.	2.90	9A630708	Receptacle, clock.....	.15
C-8	21R482726	Ceramic, disc: 10,000 mmf 450V.....	.30	43K610737	Retainer, line cord strain relief bushing (use with 43K610736 bushing).....	.20
<u>Clock</u>				9R119871	Socket, tube: miniature; 7-prong; with grounding strap; and center shield; wafer type.....	.15
E-1	59D630670	Electric Clock Assembly: Telechron; with hands; less leads.....	-	9R119819	Socket, tube: miniature; 7-prong; with dummy lug; and center shield; wafer type.....	.15
NOTE: SEE SERVICE NOTES FOR CLOCK REPAIR INFORMATION.						
<u>Coils</u>						
L-1	24C630833	Antenna Loop, Panel and Receptacle Assembly: complete.....	1.40	CABINET PARTS		
L-2	24K630800	Oscillator coil.....	1.00	16E630328	Cabinet, table model: plastic; walnut; less grille, pointer, clock overlay and crystal (53C6).	4.50
<u>Speaker</u>				16K630329	Cabinet, table model: plastic; ivory; less grille, pointer, clock overlay and crystal (53C7).	5.85
LS-1	50C630713	Speaker: 4" x 6" PM; 3.2 ohm VC.....	4.00*	16K630330	Cabinet, table model: plastic; green; less grille, pointer, clock overlay and crystal (53C8).	5.85
			exch 3.00	16K630331	Cabinet, table model: plastic; tan; less grille, pointer, clock overlay and crystal (53C9).....	5.85
<u>Resistors</u>				16C630838	Crystal, plastic (clock face cover).....	1.15
Note: All resistors are insulated carbon type unless otherwise specified.						
R-1	6R6028	22,000 20% 1/2W.....doz	1.20	13C630835	Grille, speaker: perforated metal; less medallion.....	1.35
R-2	6R3992	150 20% 1/2W.....doz	1.20	36K630829	Knob, clock control: black.....	.20
R-3	6R3927	2.2 meg 20% 1/2W.....doz	1.20	36C630827	Knob, tuning.....	1.00
R-4	6R6012	33,000 20% 1/2W.....doz	1.20	36K630828	Knob, volume.....	1.00
R-5	18A630704	Volume control: 1 meg.....	.85	13K630096	Medallion (on speaker grille)....	.10
R-6	6R2109	10 meg 20% 1/2W.....doz	1.20	2S7074	Nut, speednut (dial pointer mtg)..... per/c	.50
R-7	6R6032	470,000 20% 1/2W.....doz	1.20	13C630834	Overlay, clock background: with numbers.....	1.00
R-8	6R5683	27 10% 1/2W.....doz	1.20	28K630826	Plug, connector (connects clock to radio chassis).....	.10
R-9	6R6032	470,000 20% 1/2W.....doz	1.20	52A630830	Pointer, radio dial: red05
R-10	6R3992	150 20% 1/2W.....doz	1.20	13C630837	Trim, ornamental: on front of cabinet.....	.30
R-11	6R3953	1000 20% 1W.....	.20			
<u>Transformers</u>						
T-1,2	24C485553	IF and diode transformer: 455Kc; complete.....	1.45			
T-3	25K630836	Output transformer.....	1.55			

PRICES SUBJECT TO CHANGE WITHOUT NOTICE
*Plus Federal Excise Tax At Current Rate

MODELS 62C1, 62C1A, 62C2, 62C2A, 62C3, 62C3A, Ch. HS-299

GENERAL INFORMATION

TYPE - AC table model superheterodyne with appliance outlet and self-contained electric clock for controlling automatically the operation of the radio and the outlet.

RECEIVER MODELS	Model	Color
	62C1	Walnut
	62C2	Ivory
	62C3	Green

TUNING RANGE - 535 to 1620 Kc IF - 455 Kc

TUBE COMPLEMENT -	Type	Function
	12BD6	RF Amplifier
	12BE6	Converter
	12BD6	IF Amplifier
	12AT6	Det, AVC & AF Amp
	35C5	Power Amplifier
	35W4	Rectifier

POWER SUPPLY - Operates from 117 volts, 60 cycle, alternating current only. Power consumption 30 watts.

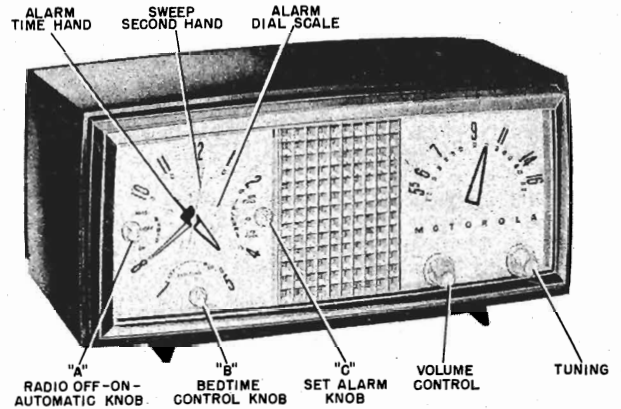

FIGURE 1. FRONT VIEW OF RECEIVER

APPLIANCE OUTLET - For use with 117 volt AC appliances only, rated at 1100 watts or less.

CLOCK - Telechron self-starting electric clock, with Motorola face and hands.

OPERATING INSTRUCTIONS

The locations and functions of the clock and radio controls are shown in Figure 1.

NORMAL RADIO OPERATION

Knob "A" on the clock turns the radio on or off. Select stations with the TUNING knob, and adjust volume with the VOLUME control.

A built-in ferrite magnetic iron core antenna eliminates the need for an outside antenna. When receiving a weak station, rotate the receiver slightly for best signal strength. CAUTION: Never connect the radio chassis to a water pipe, radiator, or other ground.

CLOCK OPERATION

The clock will start as soon as the receiver is plugged into an electrical outlet. To set the hands to the correct time, rotate the TIME SET knob (on the rear of the radio) in a clockwise direction only.

ALARM OPERATION

To set the alarm, pull out knob "C" and rotate it in a counterclockwise direction to the desired time on the alarm dial scale. The alarm will ring for one hour, or until knob "C" is pushed in. The alarm function is completely independent of the other controls on the clock.

APPLIANCE OUTLET

To control an electrical appliance automatically, plug it into the receptacle on the back of the radio. It will then be turned on or off simultaneously with the radio.

CAUTION: Note that the rating of the outlet is 1100 watts or less.

If radio reception is not desired when operating the appliance, rotate the radio volume control to the minimum volume position.

AUTOMATIC RADIO OPERATION

The clock controls may be pre-set to turn the radio on automatically at any time up to twelve hours in advance.

If an appliance is plugged into the receptacle on the back of the receiver, it will be turned on automatically, along with the radio.

Pull out knob "C", rotate it counterclockwise to the desired time on the alarm dial scale, and push the knob back in. Rotate knob "A" first to the "OFF" position and then to the "AUTO" position. At the pre-set time, the radio will come on and will continue to play until turned off manually. The alarm will ring also if the knob "C" is left pulled out. The radio will come on first and, after an interval of about ten minutes, the alarm will ring.

BEDTIME CONTROL

The BEDTIME control will turn the radio and appliance off after any pre-set interval of time up to one hour.

Turn knob "A" to the "OFF" position and rotate knob "B" to any period of time between 0 and 60 minutes. The radio and appliance will be turned off automatically after the proper time has elapsed, and they will remain off until turned on again manually.

AUTOMATIC AND BEDTIME OPERATIONS COMBINED

By combining the operations in the two sections above, the radio may be turned off automatically and on again automatically.

When setting the BEDTIME control, rotate knob "A" to the "AUTO" position instead of "OFF". IMPORTANT: It is necessary to turn knob "A" first to the "OFF" position before proceeding to "AUTO", otherwise the radio may not shut off.

CHASSIS HS-299

ALIGNMENT

NOTE: It is recommended that an isolation transformer be placed between the power line and the receiver to avoid hum and electrical shocks. If an isolation transformer is not available, connect the low side of the signal generator to B- through a .1 mf capacitor.

1. Connect a low range output meter across the speaker voice coil.
2. Connect the low side of the signal generator to B-.
3. Set the signal generator for 400 cycle, 30% modulation.

4. Turn the receiver volume control to maximum.
5. Use a small fibre screwdriver for aligning the IF and diode transformers.
6. As stages are brought into alignment, reduce the signal generator output to a level which produces less than .40 volts (.05 watt) across the voice coil to avoid overloading the receiver.
7. See Figure 2 for adjustment locations and the following chart for procedure.

ALIGNMENT CHART

STEP	DUMMY ANTENNA	GENERATOR CONNECTION	GENERATOR FREQUENCY	GANG SETTING	ADJUST	REMARKS
IF ALIGNMENT						
1.	.1 mf	Grid of conv (RF section of gang)	455 Kc	Fully open	1, 2, 3 & 4 (IF cores)	Adjust for maximum.
RF ALIGNMENT						
2.	.1 mf	Grid of conv. (RF section of gang)	1620 Kc	Fully open	5 (Osc trim)	Adjust for maximum.
3.	-	Radiation loop*	1400 Kc	Tune for max	6 (RF trim)	Adjust for maximum.
4.	-	Radiation loop*	1400 Kc	Tune for max	7 (Ant trim)	Adjust for maximum.

*Connect generator output across 5-inch diameter, 5 turn loop and couple inductively to receiver loop. Keep generator loop perpendicular to axis of and at least 12 inches from receiver iron core loop.

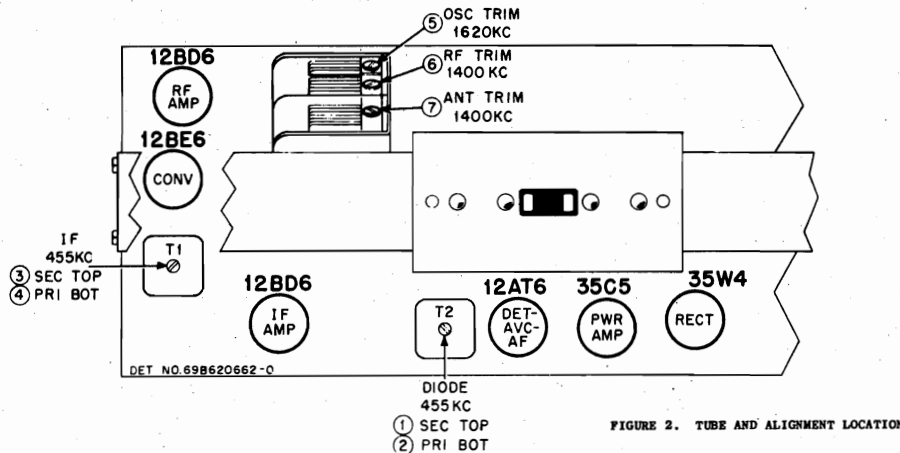

FIGURE 2. TUBE AND ALIGNMENT LOCATION

SERVICE NOTES

The chassis of this receiver is isolated from the AC power line circuit by a capacitor to eliminate the shock hazard when handling the receiver. However, as an additional precaution when aligning or servicing the receiver, an isolation transformer should be inserted between the power line and the chassis.

TO REMOVE CHASSIS FOR SERVICE

1. Remove the two screws from the bottom of the cabinet.
2. Remove the two screws from the back of the cabinet.
3. Pull the chassis and front cover from the cabinet.
4. Pull off radio and clock control knobs.

5. Insert a screwdriver into the loops on the ends of the front cover retainer springs, and pry the springs from their slots in the chassis.
6. Pull off the front cover.

TO REPLACE CLOCK DIAL BACKGROUND

1. Remove the clock from the chassis.
2. Carefully pull off the three hands.
3. Remove the alarm dial and dial background.
4. Install new background.
5. Turn the radio control shaft to "AUTO" position.

6. Slowly rotate the time set shaft clockwise until the switch contacts behind the radio control shaft close.

7. Reassemble the alarm dial and three hands. Set all the hands to indicate 12 o'clock. Set the figure "12" on the alarm dial to index with the small pointer on the hour hand.

8. Check the automatic operation to be sure the switch contacts close at the time indicated on the alarm dial.

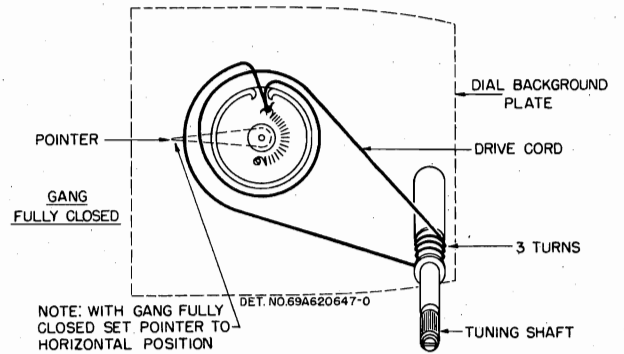

FIGURE 3. STRING DRIVE DETAIL

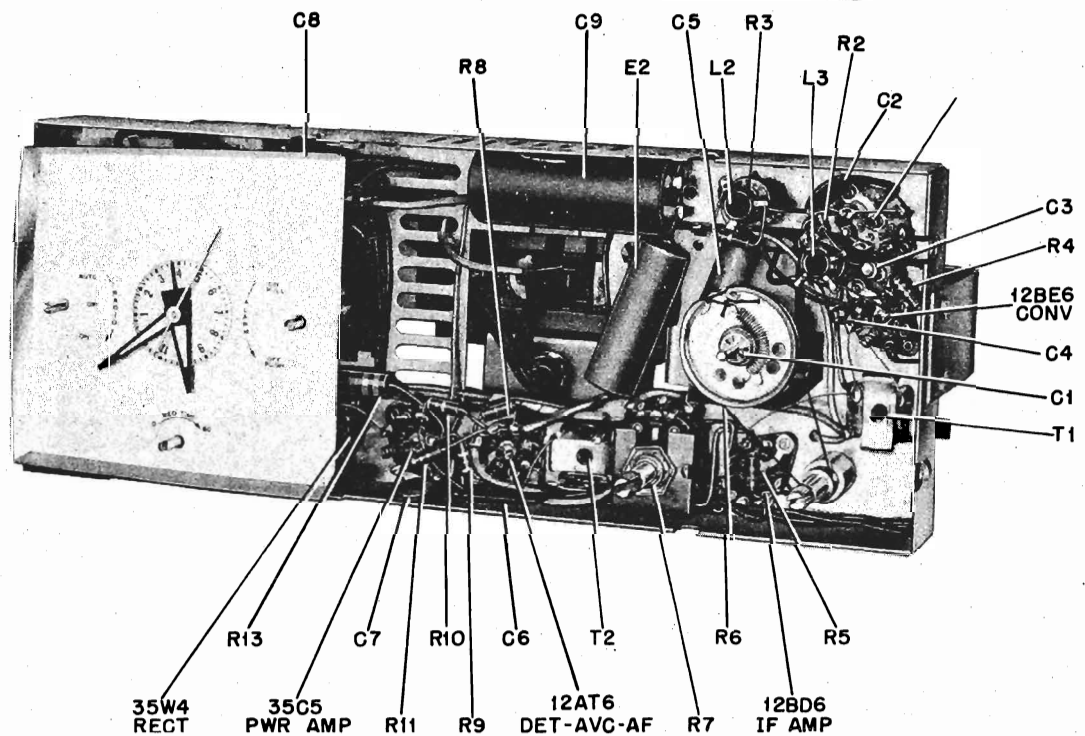
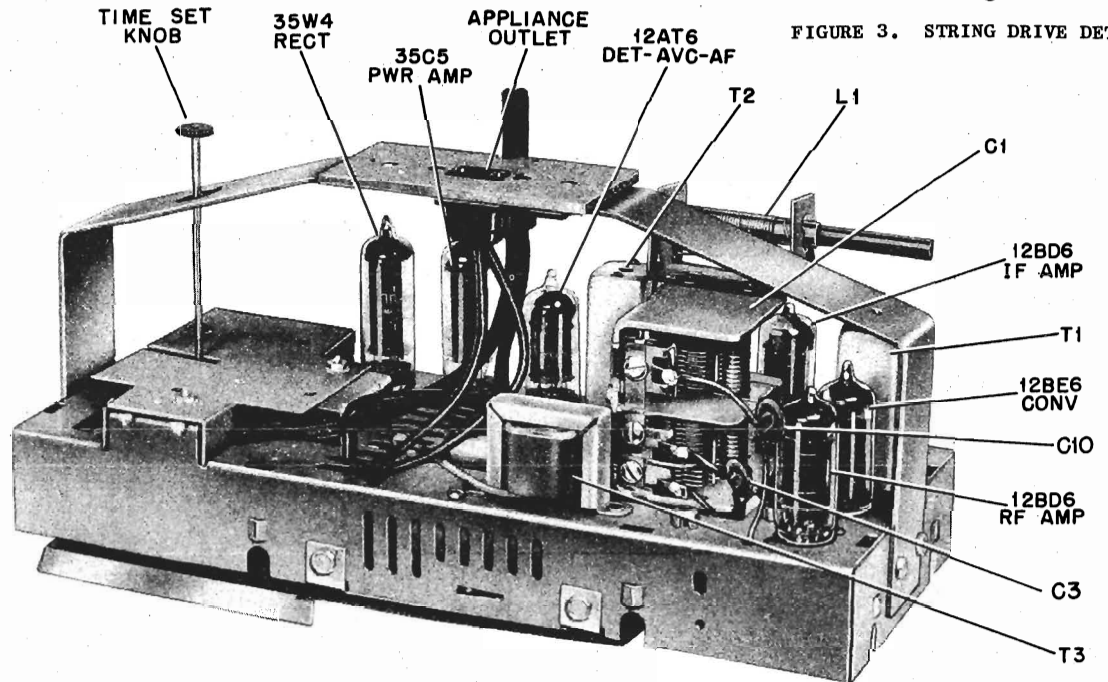
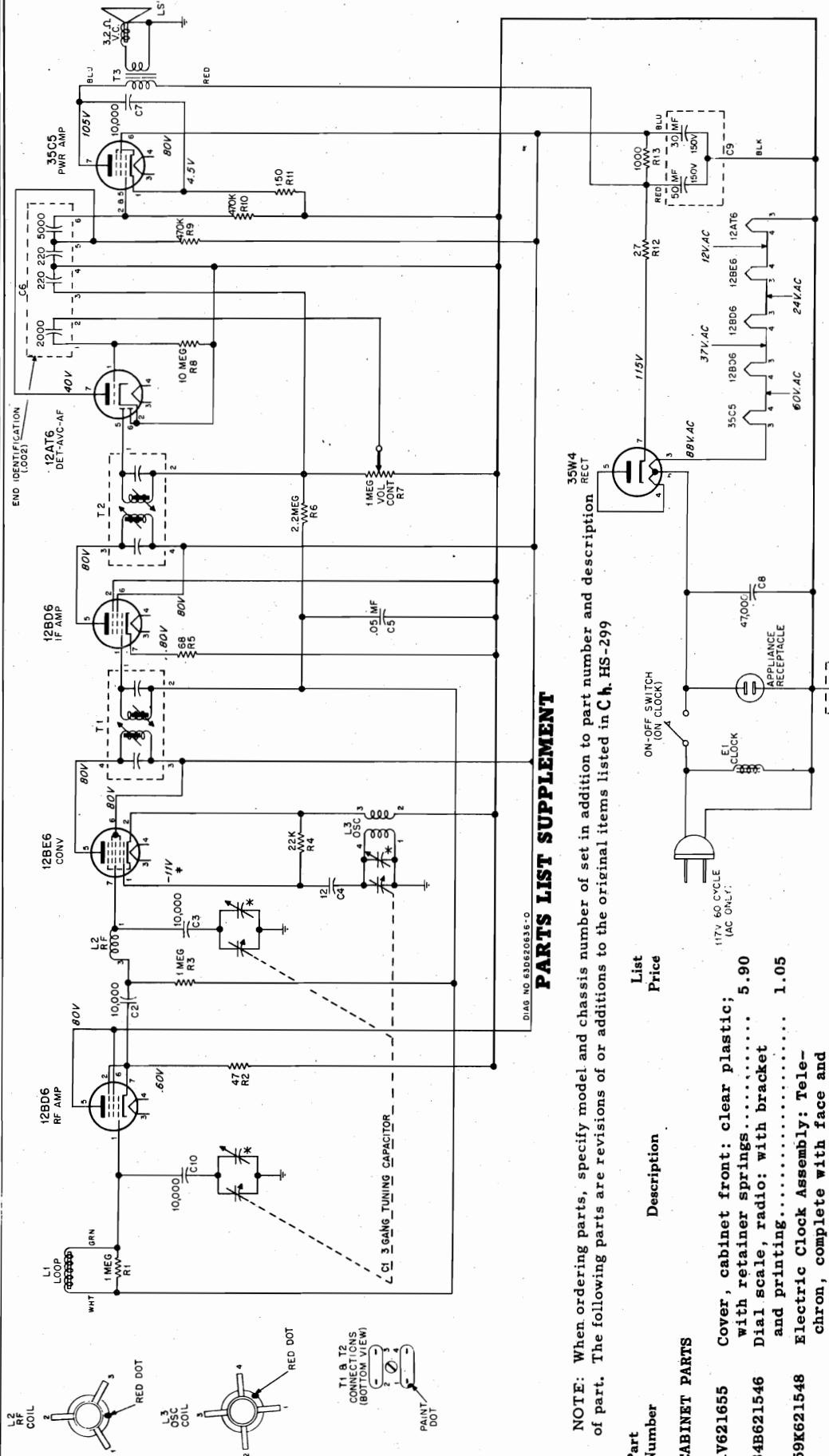

FIGURE 4. PARTS LOCATION

CHASSIS HS-299



PARTS LIST SUPPLEMENT

NOTE: When ordering parts, specify model and chassis number of set in addition to part number and description of part. The following parts are revisions or additions to the original items listed in Ch. HS-299

Part Number	Description	List Price
1V621655	Cover, cabinet front: clear plastic; with retainer springs.....	5.90
34B621546	Dial scale, radio: with bracket and printing.....	1.05
59K621548	Electric Clock Assembly: Telechron, complete with face and hands.....	12.95
36K621543	Knob, clock control: black.....	9.70
36K621539	Knob, radio control: black.....	.10
		.10

GENERAL INFORMATION

Models 62C1A, 62C2A, and 62C3A are the same as 62C1, 62C2, and 62C3, respectively, with the exception of the plastic front cover, the dial scale background, the knobs, and the electric clock, which are listed below. The re-

maining chassis parts and cabinet parts are the same as listed in Ch. HS-299

Refer to Chassis HS-299 for service instructions and alignment.

FIGURE 5. SCHEMATIC DIAGRAM

- NOTES
1. CAPACITOR INDICATED IN MMF UNLESS OTHERWISE SPECIFIED.
 2. ALL RESISTORS INDICATED IN OHMS.
 3. K=ONE THOUSAND (1000) OHMS.
 4. VOLTAGE MEASUREMENTS MADE WITH ELECTRONIC TYPE VOLTMETER.
 5. VOLTAGES TAKEN BETWEEN POINT INDICATED AND B-7.
 6. VOLTAGE TOLERANCE +10%.
 7. INPUT VOLTAGE 117V AC.
 8. NO SIGNAL INPUT.
 9. * MEASUREMENT MADE WITH GANG FULLY OPEN.
 10. * TRIMMERS ON GANG.

PARTS LIST

NOTE: When ordering parts, specify model number of set in addition to part number and description of part.

Ref. No.	Part Number	Description	List Price	CHASSIS PARTS- MECHANICAL	
CHASSIS PARTS-ELECTRICAL				7A610711 Bracket, speaker mtg..... .05	
Capacitors				43K610736 Bushing, line cord strain relief (use with 43K610737 retainer).... .20	
C-1	19B610699	Variable: 3-gang; with pulley.....	3.80	42B485548 Clip, IF trans mtg.....doz .20	
C-2	21R482726	Ceramic, disc: 10,000 mmf 450V.....	.30	30K600980 Cord, line: with plug; 6 ft lg.... 1.05	
C-3	21R482726	Ceramic, disc: 10,000 mmf 450V.....	.30	5S7805 Eyelet, snap-in (loop insulator mtg).....doz .15	
C-4	21R119131	Ceramic: 12 mmf 500V.....	.30	5A484268 Grommet, speaker mtg: rubber...doz .20	
C-5	8R9821	Paper: .05 mf 200V.....	.20	1X620223 Insulator, antenna loop: fibre; with lugs (loop mtg)..... .15	
C-6	21B482847	Ceramic, multiple: 2000, 220, 220, 5000 mmf.....	.65	35A610759 Insulator, appliance receptacle mtg: fibre.....doz .25	
C-7	21R482726	Ceramic, disc: 10,000 mmf 450V.....	.30	14B610848 Insulator, clock: fibre (behind clock)..... .15	
C-8	8R490232	Molded paper: 47,000 mmf 400V	.30	2S7051 Nut, hex: Palnut; 3/8-32 x 9/16 (volume control mtg).....doz .15	
C-9	23B600855	Electrolytic: 30-50 mf/150V	1.60	51B611046 Plate, dial background (radio dial): silver color..... .75	
C-10	21R482726	Ceramic, disc: 10,000 mmf 450V	.30	52A610731 Pointer, radio dial: luminous..... .60	
Clock				9A601018 Receptacle, appliance..... .80	
E-1	59D610689	Electric Clock Assembly: Telechron; complete with face and hands.....	12.95	43K610737 Retainer, line cord strain relief bushing (use with 43K610736 bushing)..... .20	
				64A611059 Screen, speaker..... .60	
				1V620998 Shaft, tuning: with pulley..... .35	
				9A690129 Socket, tube: 7-prong; miniature.. .15	
				41A14244 Spring, tension (gang drive cord).....doz .55	
Choke-Capacitor				4K692188 Washer, "C" (tuning shaft mtg).doz .20	
E-2	8K620968	Choke and .10 mf paper capacitor.....	.65	CABINET PARTS	
Coils				16E610742 Cabinet, table model: plastic; walnut (62C1)..... 5.75*	
L-1	24K610726	Antenna loop: with core.....	.90*	16K610743 Cabinet, table model: plastic; ivory (62C2)..... 6.75*	
L-2	24B610698	RF coil.....	.70	16K610744 Cabinet, table model: plastic; green (62C3)..... 6.75*	
L-3	24A610695	Oscillator coil.....	.80	1X611053 Cover, cabinet front: clear plastic; painted and lettered; complete with retainer springs... 6.35	
Speaker				36K610818 Knob, clock control: gray..... .10	
LS-1	50K610739	Speaker: 4" PM; 3.2 ohm VC; less screen & mtg brackets.....	3.90*	36K610816 Knob, radio control: gray..... .10	
				41A610758 Spring, retainer (cabinet front mtg).....doz .30	
Resistors				CLOCK PARTS	
Note: All resistors are insulated carbon type unless otherwise specified.				Note: The following Motorola parts are for use with the basic Telechron clock movement.	
R-1	6R6046	1 meg 10% 1/2W.....doz	1.20	34K610691 Alarm dial: silver color..... .50	
R-2	6R5550	47 10% 1/2W.....doz	1.20	52K610692 Hand, hour: luminous..... .50	
R-3	6R6004	1 meg 20% 1/2W.....doz	1.20	52K610693 Hand, minute: luminous..... .50	
R-4	6R6028	22,000 20% 1/2W.....doz	1.20	52K610694 Hand, second: gold color..... .15	
R-5	6R6007	68 20% 1/2W.....doz	1.20	36K601002 Knob, time set..... .25	
R-6	6R3927	2.2 meg 20% 1/2W.....doz	1.20	59K610568 Motor, clock (rotor assembly only) 3.40	
R-7	18A610819	Volume control: 1 meg.....	.80	34K610690 Plate, dial background: silver color..... 1.50	
R-8	6R2109	10 meg 20% 1/2W.....doz	1.20		
R-9	6R6032	470,000 20% 1/2W.....doz	1.20		
R-10	6R6032	470,000 20% 1/2W.....doz	1.20		
R-11	6R6373	150 10% 1/2W.....doz	1.20		
R-12	6R5683	27 10% 1/2W.....doz	1.20		
R-13	6R476004	1000 20% 2W.....	.25		
Transformers				PRICES SUBJECT TO CHANGE WITHOUT NOTICE	
T-1,2	24C485553	IF and Diode Transformer: 455 Kc: complete.....	1.45	*Plus Federal Excise Tax At Current Rate	
T-3	25K610738	Output transformer.....	1.50		

Frequency Range:

BATTERIES: 1 - 1 1/2v Eveready #950, or Burgess 2R or Ray-O-Vac 2LP or equivalent.
 1 - 67 1/2v Eveready #467, or Burgess XX45 or equivalent.

Model 489 is a 4 tube battery operated portable superheterodyne radio receiver with a built-in loop antenna. This antenna is contained in the cover of the receiver and to avoid impairment of reception it is advisable not to rest the cover against any metallic surface. Since all loop antennas are directional, reception may be improved by orienting the position of the set for best reception of the desired station.

An automatic OFF-ON switch turns the receiver ON when the cover is opened and OFF when the cover is closed. Since the useful life of the batteries is limited it is important to CLOSE the cover when the set is not in use. Battery power is consumed as long as the cover is open, although no sound is audible.

CAUTION: WHEN OPENING OR CLOSING THE COVER OR THE BOTTOM OF THE RECEIVER MOVE THE SMALL BUTTON OF THE CATCH IN THE DIRECTION OF THE ARROW. DO NOT SLAM THE COVER AS THIS MAY DAMAGE THE CATCH MECHANISM.

Controls:

There are two receiver controls. The left knob serves as a volume control but does not turn the receiver ON or OFF. The right knob is the TUNING control.

To exchange the batteries, keep the receiver cover closed. Turn the receiver face down and move the button which is on the short side, in the direction of the arrow. Opening the bottom of the receiver will permit access to the batteries. **WHEN BATTERIES HAVE RUN DOWN ALWAYS REMOVE THEM FROM THE RECEIVER AS WORN OUT BATTERIES HAVE A TENDENCY TO SWELL AND SOMETIMES LEAK, CAUSING DAMAGE TO THE RECEIVER.**

SERVICE AND ALIGNMENT INSTRUCTIONS

Equipment required: Modulated A-M, R-F signal generator, vacuum tube voltmeter or output meter, insulated screw driver, radiation loop (1 turn of about 6" or 8" or #12 or #14 wire connected across output of signal generator and placed parallel to receiver loop about 8" or 10" away), one .1/400v condenser.

With the receiver bottom open, connect output meter or vacuum tube voltmeter and signal generator as directed in the alignment procedure chart and keeping the output of the generator as low as possible, proceed exactly in the sequence shown in the chart.

Before aligning close the variable condenser fully counterclockwise (plates fully closed) and check pointer position.

ALIGNMENT PROCEDURE CHART

STEP	CONNECT HIGH SIDE OF SIGNAL GENERATOR TO-	SET SIGNAL GENERATOR TO-	SET POINTER TO-	ADJUST THE FOLLOWING FOR MAXIMUM OUTPUT. (KEEP SIGNAL FROM SIGNAL GENERATOR AS LOW AS POSSIBLE.)
1	R. F. SECTION OF VARIABLE CONDENSER IN SERIES WITH A .1MFD. 400VOLT CONDENSER.	455 KC.	EXTREME RIGHT HAND POSITION (CONDENSER PLATES FULLY OPEN)	C6, C5, C4, C3 AND REPEAT IN SAME ORDER (1st. AND 2nd. I.F. TRANSFORMERS.)
2	USE RADIATED SIGNAL	1600 KC.	1600 KC. (160 ON DIAL)	C2 (OSCILLATOR TRIMMER)
3	(CONNECT BOTH SIDES OF SIGNAL GENERATOR TO RADIATION LOOP)	1400 KC.	MAXIMUM SIGNAL (APPROX. 140 ON DIAL)	C1 (ANTENNA TRIMMER)
4		600 KC.	MAXIMUM SIGNAL (APPROX. 60 ON DIAL)	ADJUST L1 (ROCK VARIABLE FOR MAXIMUM SIGNAL.)
5	REPEAT STEPS 2,3 & 4 AT LEAST TWICE TO INSURE MAXIMUM SENSITIVITY & PROPER DIAL TRACKING.			

MODEL 489

CIRCUIT DIAGRAM

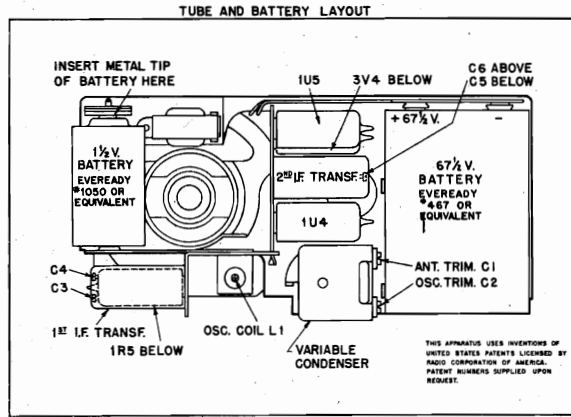
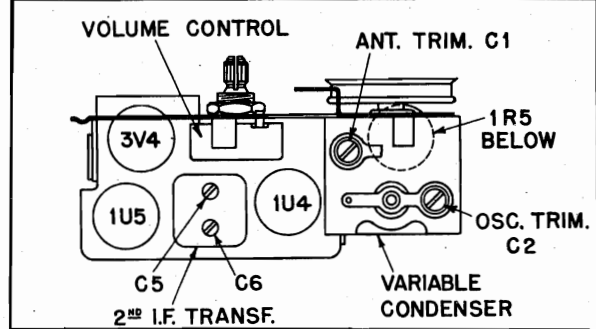
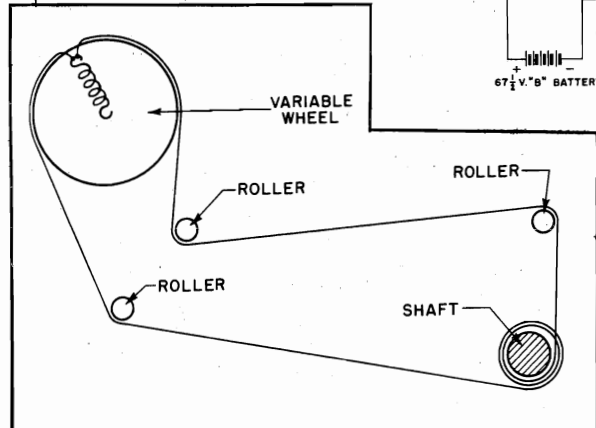
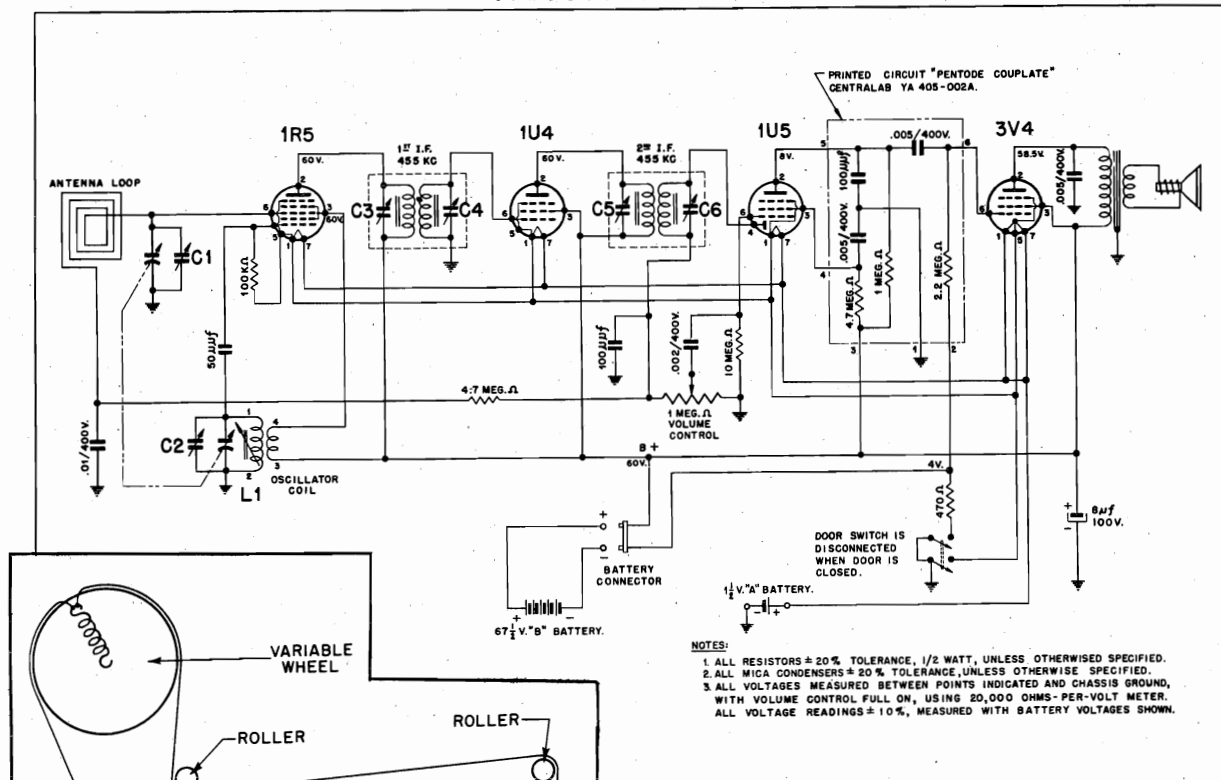

PARTS LIST

Part No.	Description	Part No.	Description
CL-2531	Coil—Oscillator Coil	MS-1403	I.F. Mounting Clip
CO-1323	Condenser—8 MFD 100 W.V. Electrolytic Condenser	PC-2489	Pentode Couplate Network
CV-1291-1	Condenser—Variable Condenser (2 Section)	PO-1310	Pointer
ES-1288	Escutcheon	PP-1317	"B" Battery Snap Connector Assembly
KN-1309	Knob	PT-1313	1 Meg. Volume Control
LP-1316	Loop	SH-1284	Drive Shaft Assembly
MP-1290	Moulded Cover	SK-1283	Speaker—3½" P.M. Speaker (.68 oz. Alnico)
MP-1292	Moulded Case	SP-1286	Spring—Pointer Drive Spring
MP-1302	Plastic Handle	SW-1280	Switch—Door Switch
MP-1306	Loop Cover, Moulded	TR-1279	Transformer—Output Transformer
		TR-1314	Transformer—I.F. Transformer

Frequency Range Broadcast 540 k-c to 1610 k-c — Shortwave 4.75 m-c to 16.1 m-c

Power Requirement 105-125 Volts d-c or 50 to 60 cycles a-c

Power Consumption 30 watts

Model 9-435 is a 5 tube (four tubes plus rectifier) a-c or d-c operated 2 band superheterodyne receiver employing a built in loop antenna which will provide satisfactory reception under normal operating conditions. This type of antenna is directional and noise or interference from other stations can be minimized by rotating the receiver. If the receiver is used in locations where signal strength is very low, as in steel buildings, or in locations remote from broadcast stations, an outside antenna may be connected to a lead protruding through the back of the cabinet. For satisfactory reception on short wave, an outside antenna is essential. A ground connection is unnecessary.

On d-c operation, if no signal is heard after about one minute warm up period, reverse the line plug. If a slight hum is heard on a-c operation a similar reversal of the plug may reduce the hum.

CONTROLS

The receiver has three control knobs marked according to their function, reading from left to right as follows:

1. OFF-ON-VOLUME
2. BC-SW
3. TUNING

TUNING

To place this receiver in operation insert the line plug into a suitable electric outlet of 105-125 volts d-c or 50-60 cycles a-c. For operation on 220 volts d-c or 50-60 cycles a-c an adapter cord our part number LC530 must be inserted between the line plug and the electric outlet.

Then turn the OFF-ON knob clockwise until a click is heard. Allow about one half minute warm-up period for the tubes before the set is ready to function.

BROADCAST

For broadcast reception turn BC-SW knob counter-clockwise to the BC position. The Tuning knob should now be turned until the dial pointer is at the frequency of the desired station. Dial numbers are converted to kilocycles by adding one zero. For example, 70 on the dial is 700 kilocycles. With the volume control set to low volume level turn the Tuning knob until the desired station is received loudest. Now adjust volume control to the desired level and tone control to the desired tone. **DO NOT USE TUNING KNOB TO ADJUST VOLUME BY TUNING OF STATION AS THIS WILL RESULT IN POOR TONE QUALITY.**

NOTE: In case of dial light failure, replace the lamp (Mazda #47) as soon as possible to prevent damage to the 35Z5 tube.

SHORT WAVE

For short wave reception turn BC-SW knob clockwise to SW position and tune to the desired frequency in the same manner as described for broadcast reception. Use the lower part of the dial scale calibrated in megacycles and meters. The tuning on the short wave band should be very slow as the dial setting is very sensitive and stations may be "passed by" very easily.

MODELS 9-435W,
9-435V

ALIGNMENT INSTRUCTIONS

Equipment required: Modulated r-f signal generator, output meter, insulated screw driver, two .1mfd. 400 V. Condensers, one 400 ohms resistor.

To align the receiver it is necessary to remove the chassis from the cabinet, check that the pointer is horizontal and coincides with the two horizontal reference lines on the dial. In this position the condenser should be completely closed. Turn volume control to maximum and connect the output meter across the voice coil.

Then connect the low side of the signal generator to the receiver chassis through a .1 mfd. condenser and keeping the output as low as possible proceed in the sequence as shown on the alignment chart.

To insure alignment a radiated signal will be required during part of the alignment procedure. To radiate a signal connect a loop of about 6" to 8" diameter, (one turn of #14 or #12 wire) across the output of the signal generator and place this loop parallel to the loop of the receiver to be aligned, at a distance of about 8" or 10".

ALIGNMENT PROCEDURE CHART

STEP	SET BAND SWITCH ON	CONNECT HIGH SIDE OF SIGNAL GENERATOR TO—	SET SIGNAL GENERATOR TO—	TURN RECEIVER DIAL TO—	ADJUST THE FOLLOWING FOR MAXIMUM OUTPUT. (KEEP SIGNAL FROM SIGNAL GENERATOR AS LOW AS POSSIBLE).
1	B. C.	R.F. SECTION OF VARIABLE CONDENSER OR PIN 4 OF THE 12SK7 TUBE IN SERIES WITH A .1MFD. 400 VOLT CONDENSER.	455 KC.	FULL CLOCKWISE POSITION (CONDENSER PLATES FULLY OPEN).	L4 AND L3 (2 ND I.F. TRANSFORMER)
2	B. C.	R.F. SECTION OF VARIABLE CONDENSER OR PIN 8 OF THE 12SA7 TUBE IN SERIES WITH A .1MFD. 400 VOLT CONDENSER.	455 KC.	FULL CLOCKWISE POSITION (CONDENSER PLATES FULLY OPEN).	L2 AND L1 (1 ST I.F. TRANSFORMER)
3	B. C.	REPEAT STEPS 1 AND 2			
4	B. C.	USE RADIATED SIGNAL (CONNECT BOTH SIDES OF SIGNAL GENERATOR TO RADIATION LOOP).	1600 KC. (160 ON DIAL)	1600 KC. (160 ON DIAL)	C3 (OSCILLATOR TRIMMER)
5	B. C.		1400 KC.	MAXIMUM SIGNAL (APPROX. 140 ON DIAL)	C1 (ANTENNA TRIMMER)
6	B. C.		600 KC.	MAXIMUM SIGNAL (APPROX. 60 ON DIAL)	C5 (PADDER) ROCK VARIABLE FOR MAXIMUM SIGNAL
7	B. C.	REPEAT STEPS 4, 5, AND 6			
8	S. W.	ANTENNA WIRE ON LOOP IN SERIES WITH A 400 OHM RESISTOR.	15 MC.	15 MC. (APPROX. 15 ON DIAL)	C4 (OSCILLATOR TRIMMER) SECOND PEAK FROM TIGHT POSITION C2 (ANTENNA TRIMMER)
9	S. W.		5.5 MC.	RESONANCE (APPROX. 5.5 ON DIAL)	CHECK THAT POINTER (AT RESONANCE) COINCIDES WITH 5.5 MC. CALIBRATION POINT ON DIAL. IF NOT REPEAT STEP 8.

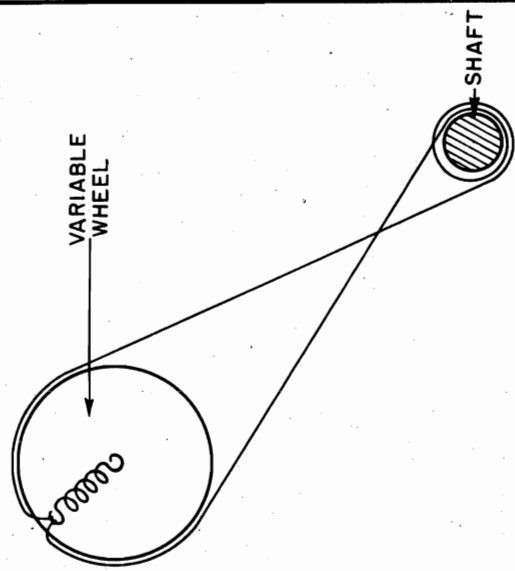

TUBE LAYOUT

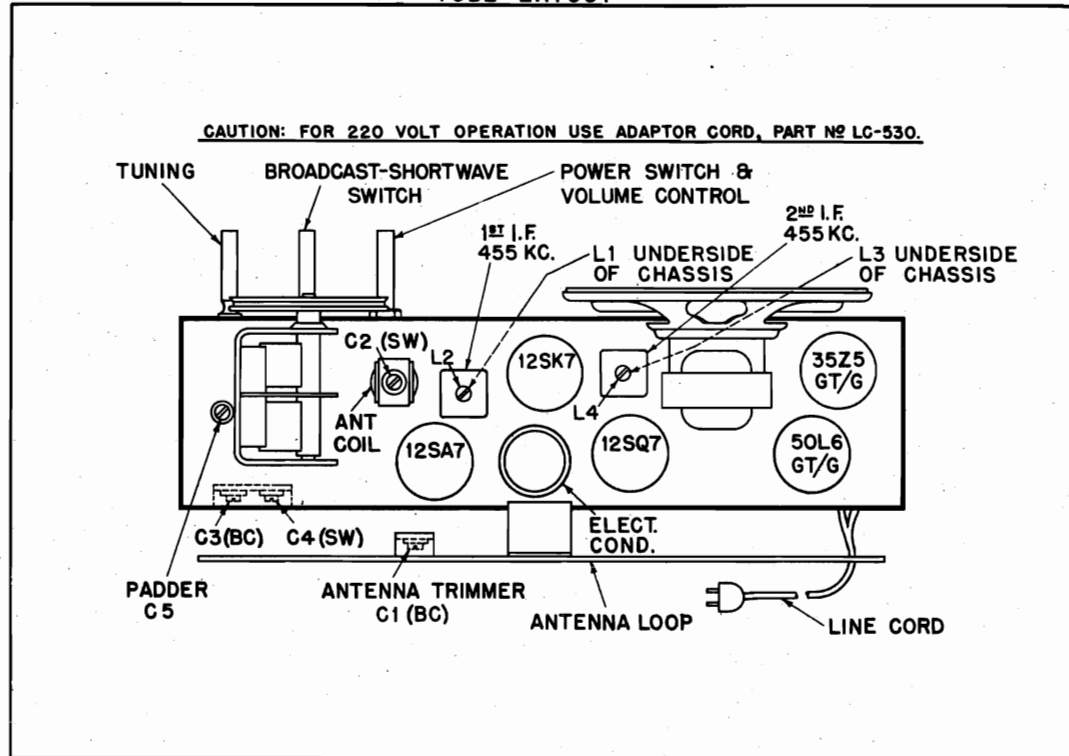

Part No.	Description
BU-187	Bulb—#47 Mazda pilot light bulb
CA-327W	Cabinet—walnut bakelite cabinet
CA-327V	Cabinet—ivory bakelite cabinet
CL-933	Coil—broadcast and shortwave oscillator coil
CL-940	Coil—shortwave antenna coil
CO-1715	Condenser — 40/40/150 W.V. electrolytic condenser
CT-389	Condenser — 3-35 mmfd. dual trimmer condenser
CT-440	Condenser — 350-780 mmfd. padder condenser
CT-939	Condenser—3-35 mmfd. trimmer condenser
CV-772	Condenser—2 section ganged variable condenser
DL-934	Dial—dial scale
KN-1077	Knob—walnut knob marked "Off-On-Volume"
KN-1078	Knob—walnut knob marked "Tuning"
KN-1085	Knob—walnut knob marked "BC-SW"
KN-1103	Knob—ivory knob marked "Off-On-Volume"
KN-1104	Knob—ivory knob marked "Tuning"
KN-1105	Knob—ivory knob marked "BC-SW"
LP-937	Loop—loop antenna
PO-259W	Pointer—moulded pointer (walnut)
PO-259V	Pointer—molded pointer (ivory)
PT-102	Control—1/2 megohm volume control with off-on switch
RCM20A101M	Condenser—100 mmfd. ±20% mica condenser
RCM20A221M	Condenser—220 mmfd. ±20% mica condenser
RCM20A331M	Condenser—330 mmfd. ±20% mica condenser

Part No.	Description
RCM20A470M	Condenser—47 mmfd. ±20% mica condenser
RCM30B402J	Condenser—4000 mmfd. ±5% mica condenser
RCP10W4104L	Condenser—.1/400 W.V. tubular paper condenser*
RCP10W4203A	Condenser—.02/400 W.V. tubular paper condenser
RCP10W4503A	Condenser—.05/400 W.V. tubular paper condenser
RCP10W6103A	Condenser—.01/600 W.V. tubular paper condenser
RCP10W6502A	Condenser—.005/600 W.V. tubular paper condenser
REB-105M	Resistor—1 megohm ±20% 1/2 watt resistor
REB-106M	Resistor—10 megohms ±20% 1/2 watt resistor
REB-151K	Resistor—150 ohms ±10% 1/2 watt resistor
REB-223M	Resistor—22,000 ohms ±20% 1/2 watt resistor
REB-224M	Resistor—220,000 ohms ±20% 1/2 watt resistor
REB-225M	Resistor—2.2 megohms ±20% 1/2 watt resistor
RE-473M	Resistor—47,000 ohms ±20% 1/2 watt resistor
REB-474M	Resistor—470,000 ohms ±20% 1/2 watt resistor
REC-221K	Resistor—220 ohms ±10% 1 watt resistor
RED-102M	Resistor—1000 ohms ±20% 2 watt resistor
SK-838-1	Speaker—5" p.m. speaker
SP-191	Spring—drive shaft retaining spring
SP-295	Spring—dial drive spring
ST-255-1	Back—cardboard back
SW-839	Switch—4 P.D.T. band switch
TR-1644	Transformer—455 k-c I.F. transformer

*When ordering be sure to specify with r-f choke

MODELS 9-435W,
9-435V

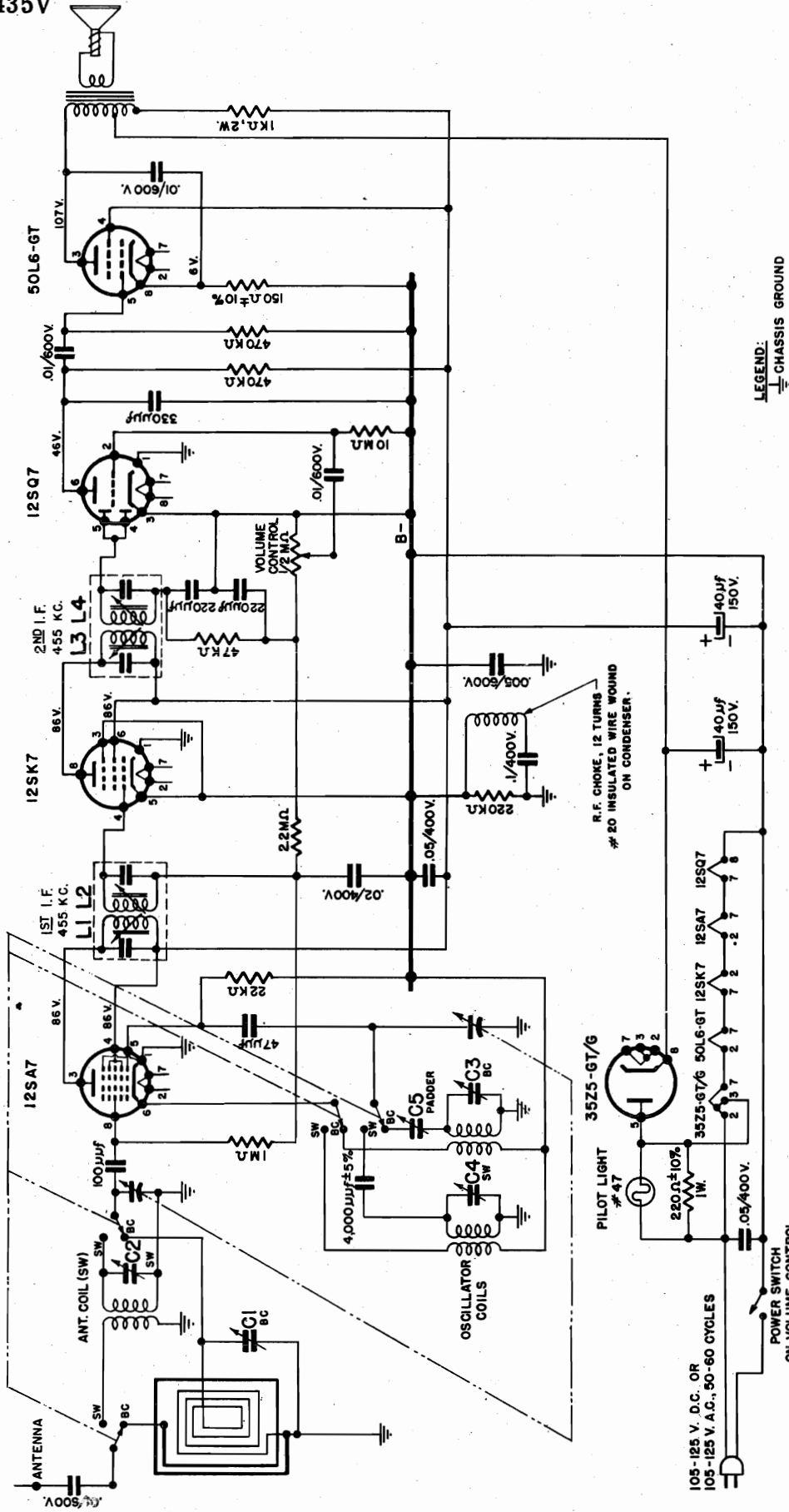

- LEGEND:
 CHASSIS GROUND
- NOTES:
 1. ALL RESISTORS ±20% TOLERANCE, 1/2 WATT, UNLESS OTHERWISE SPECIFIED.
 2. ALL MICA CONDENSERS ±20% TOLERANCE, UNLESS OTHERWISE SPECIFIED.
 3. ALL VOLTAGES MEASURED BETWEEN POINTS INDICATED AND B-, WITH VOLUME CONTROL FULL ON, AND WITH BAND SWITCH SET IN "BC" POSITION, USING 20,000 OHMS-PER-VOLT METER. ALL READINGS ±10%, MEASURED WITH INPUT VOLTAGE OF 117 V., 60 CYCLES A.C.

CIRCUIT DIAGRAM

430Ω
 FOR 230 V. D.C. OR 230 V. 50-60 CYCLES A.C. OPERATION,
 USE LINE ADAPTER CORD, PART LC-550.

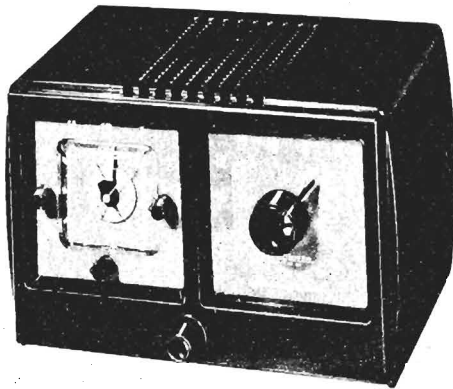

Figure 1. Automatic Clock-Controlled Radio.

DESCRIPTION

Model 621 Automatic Clock-Controlled Radio is a six tube superheterodyne receiver contained in brown or ivory plastic cabinet. A PM (Permanent Magnet) speaker is used with the radio and the tubes are standard miniature tubes. The clock is a Telechron movement and is equipped with alarm.

SPECIFICATIONS:

Overall Dimensions:

Height — 6 inches
Width — 5 inches
Length — 10 inches
Weight — 6 pounds

Electrical Rating:

Line Voltage — 110-120 AC 60 cycle only
Power Consumption — 28 watts

Tuning Frequency Range:

540 to 1620 KC

Intermediate Frequency:

455 KC

Electrical Power Output (Maximum):

1.7 watts

Loudspeaker:

Type — permanent magnet
Outside Cone Diameter — 4 inches
Voice Coil Impedance — 3.2 ohms @ 400 C.P.S.*
Magnet Rating — .68 Oz Alnico V.

*NOTE: Production runs were made using an 83009 speaker of 6 ohms impedance at 400 C.P.S. In those cases, T1 was 2500 to 6 ohm output, Part No. 89433.

TUBE COMPLEMENT:

NO.	TUBE	FUNCTION
V-1	6BJ6	R-F Amplifier
V-2	12BE6	Frequency Converter
V-3	6BJ6	I-F Amplifier
V-4	12AV6	2nd Detector — 1st Audio
V-5	50C5	Power Amplifier
V-6	35W4	Rectifier

SPECIAL SERVICE INFORMATION:

Resistances measured are D-C. Allow a 10% tolerance between values given and readings made.

1st I-F Coil:

Primary — 17.5 ohms
Secondary — 17.5 ohms

2nd I-F Coil:

Primary — 12.2 ohms
Secondary — 11.5 ohms

Oscillator Coil:

Primary — 1 ohm
Secondary — 5.5 ohms

I-F Trap:

Primary — 31.5 ohms

Ferro Loop:

Resistance — 1 ohm

SOCKET VOLTAGES:

The voltages shown on Schematic Diagram, figure 4, were measured under the following conditions:

1. D.C. Voltages with a vacuum tube voltmeter from socket contacts to B minus.
2. Filament voltages measured with a 1,000 ohms per volt A.C. meter across the filament of each tube.
3. Volume and Tone Controls maximum.
4. 117 volts A.C. line.
5. Voltages are subject to a 10% variation.

For voltages, see figure 4.

OSCILLATOR CATHODE VOLTAGES:

Measured with an A-C vacuum tube voltmeter (input impedance above 10 megohms) at 117 volts — A-C line.

1500 KC — 1.0 VAC
1000 KC — 1.0 VAC
750 KC — 1.1 VAC
540 KC — 1.1 VAC

MODEL 621

OPERATING INSTRUCTIONS**GENERAL:**

This clock-radio operates on 110-120 volt, 60-cycle alternating current only.

The clock movement is self-starting and will begin operating when the cord is plugged into the proper outlet. The correct time is set by means of the Time Set Control at the right rear of the chassis. Turn the Time Set Control in a Clockwise Direction Only as Viewed From the Rear.

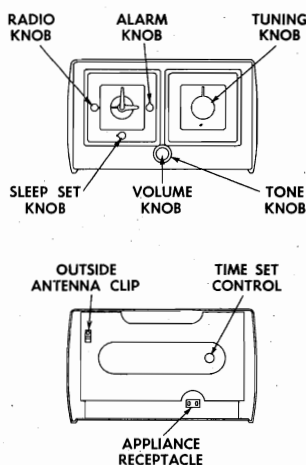

Figure 2. Controls and Connections.

AWAKE TO MUSIC AND BUZZER ALARM:

1. Adjust the radio for normal operation.
2. Pull out Alarm Knob and set the small, rotating alarm dial for the desired awakening time. Turn Alarm Knob in counterclockwise direction only.
3. Turn the Radio Knob to the "AUTO" position.*

*NOTE: Music will turn on exactly as set. Buzzer Alarm will sound ten minutes later as a reminder.

4. Push Alarm Knob in if buzzer alarm is not desired.

TO OPERATE THE RADIO ONLY:

1. Turn the Radio Knob to the "ON" position.
2. Turn the Volume Knob to about middle position.
3. Select desired station with the Tuning Knob.
4. Adjust the Volume and Tone Knobs as desired.

TO AWAKEN TO BUZZER ALARM ONLY:

1. Pull out Alarm Knob and set the small, rotating alarm dial for desired awakening time. Turn Alarm Knob in counterclockwise direction only.
2. Turn Radio Knob to "OFF" position.
3. Allow Alarm Knob to remain in the out position.

FOR SLUMBER MUSIC UP TO 60 MINUTES DURATION:

1. Adjust the radio for normal operation.
2. Turn the Sleep Set Knob fully clockwise. Radio will operate 60 minutes, then shut off automatically. For playing time less than 60 minutes, set knob accordingly.
3. Turn Radio Knob to "AUTO" position.

CLOCK REPLACEMENT**GENERAL:**

When the clock becomes defective, do not attempt to repair it; replace it.

Tools required to replace clock are: soldering iron and ¼-inch spin-tite wrench.

CLOCK REPLACEMENT PROCEDURE:

1. Remove all control knobs. (Do not lose metal clip inside Volume Knob.)
 2. Remove three screws from bottom of cabinet.
 3. Remove chassis.
 4. Remove back and slide to one side being careful not to break loop leads.
 5. Remove three screws from face and remove dial face, backing card, and dial-face gasket. (Be sure to replace spacer between backing card and chassis behind the lower right hand screw during reassembly.)
 6. Remove 12AV6, 50C5, and 35W4 tubes from chassis. (See tube location diagram on back of radio.)
 7. Remove two screws, located on the left side (viewing the radio from the front) of clock bracket, which hold cover in place. Remove cover.
 8. Unsolder wires at clock, leading to chassis.*
- *NOTE: A-C leads to clock switch must be replaced so that the leads are fastened to the same points as before disassembly.
9. Remove three nuts located on back of clock cover and remove clock.
 10. Reassemble clock-radio following above procedure in the inverse order.

ALIGNMENT PROCEDURE

Alignment procedure consists of the step outlined in the Alignment Chart. See Figure 3 for location of trimmers. Make certain each step is done with a minimum input signal. Connect output meter to speaker voice coil.

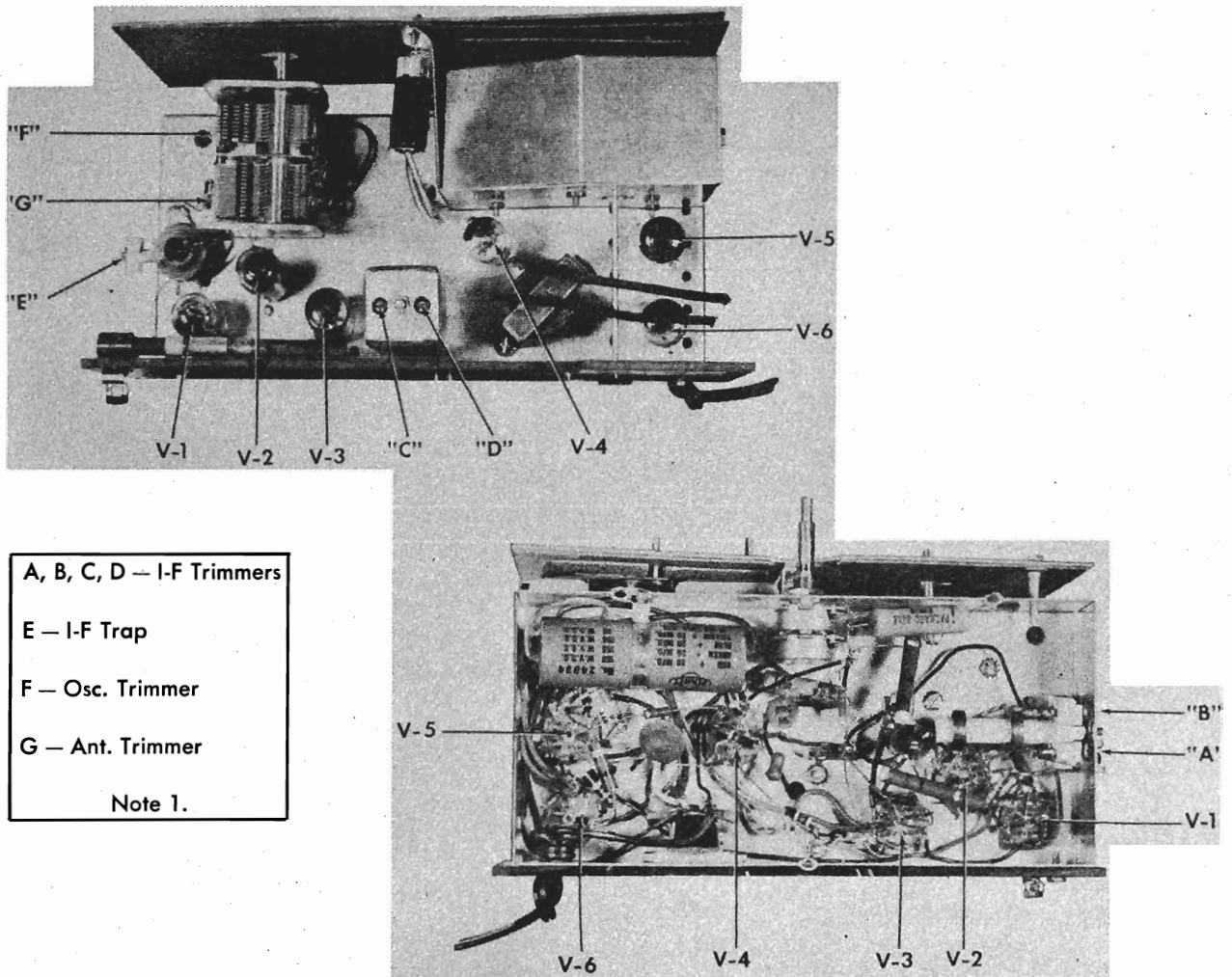

- A, B, C, D — I-F Trimmers
 - E — I-F Trap
 - F — Osc. Trimmer
 - G — Ant. Trimmer
- Note 1.

Figure 3. Chassis.

STEP	CONNECT TEST OSC. TO	TEST OSC. SETTING	POINTER SETTING	ADJUST FOR MAX. OUTPUT
1	Mixer Grid & Ground	455 KC	540 KC	Trimmers A,B,C & D
2	Mixer Grid & Ground	455 KC	540 KC	Trimmer E for minimum output
3	Mixer Grid & Ground	1620 KC	1620 KC	Trimmer F
4	Test Loop	1500 KC	1500 KC	Trimmer G
5	REPEAT STEPS 3 & 4			

Note 2.

REPLACEABLE PARTS

To be assured of genuine Packard-Bell replacement parts, order by the Packard-Bell part number from any of the following Packard-Bell Service Divisions.

LOS ANGELES	1101 So. Hope Street
SEATTLE	2310 Fourth Ave.
SAN DIEGO	3069 El Cajon Blvd.
SAN FRANCISCO	1157 Post Street
RIVERSIDE	247 La Cadena Drive
SALT LAKE CITY	624 So. State Street
SOUTH GATE	8640 State Street

REF. SYMBOL	DESCRIPTION	P.B. PART NO.	REF. SYMBOL	DESCRIPTION	P.B. PART NO.
CAPACITORS			RESISTORS		
C1A			R1	Carbon, 120 ohms, 1/2 watt, 10%	73014
& B	Variable, 2 gang	23528	R2	Carbon, 4700 ohms, 1/2 watt, 10%	73033
C2	Tubular, .1 Mfd. 200 volt	23019	R3	Carbon, 1 megohm, 1/2 watt, 10%	73161
C3	Ceramic, 220 Mmf. G.P.	23915	R4	Carbon, 22,000 ohms, 1/2 watt, 10%	73041
C4	Ceramic, 220 Mmf. G. P.	23915	R5	Carbon, 2.2 megohms, 1/2 watt, 20%	73165
C5	Tubular, .05 Mfd. 200 volt	23017	R6	Carbon, 220 ohms, 1/2 watt, 10%	73017
C6	Ceramic, 220 Mmf. G.P.	23915	R8	Carbon, 4.7 megohms, 1/2 watt, 20%	73169
C7	Ceramic, 5000 Mmf. G.P.	23931	R9	Carbon, 470,000 ohms, 1/2 watt, 20%	73157
C8	Ceramic, 470 Mmf. G.P.	23916	R10	Carbon, 150 ohms, 1/2 watt, 10%	73015
C9	Ceramic, 10,000 Mmf. G.P.	23939	R11	Carbon, 180 ohms, 1 watt, 10%	73216
C10	Ceramic, 5000 Mmf. G.P.	23931	R12	Carbon, 1000 ohms, 1 watt, 10%	73225
C11A	Electrolytic, 20 Mfd. 25 volt	24034	TRANSFORMER		
C11B	Electrolytic, 30 Mfd. 150 volt	24034	T1	Output, 2,500 to 3.2 ohms	89417
C11C	Electrolytic, 20 Mfd. 150 volt	24034	*See note.		
C11D	Electrolytic, 20 Mfd. 150 volt	24034	MISCELLANEOUS PARTS		
C12	Tubular, .005 Mfd. 600 volt	23004	Cabinet (specify color)		521-621
C13	Tubular, .05 Mfd. 200 volt	23017	Ferro-Loop Antenna		29343A
CONTROLS			A.C. Cord, 6 ft.		32011
R7A			Dial, Stationized		38128
& B	Volume and Tone (Dual) 500,000 ohms.	25026	Clock Assembly		58038
COILS			Clock Knobs (specify color)		58038-1
L-1	I-F Trop	29005	Tuning Knob (specify color)		52079
L-2	Oscillator	29220	Volume Knob (specify color)		52074
L-3	1st I-F, 455 KC	29045	Tone Knob (specify color)		52073
L-4	2nd I-F, 455 KC	29046	Dial Lamp No. T-47		54002
L-5	Loop	29343A	A-C Socket		79096
			Dial Lite Socket		79082
			Tube Socket, 7 pin miniature		79067
			Speaker, 4-inch P.M.		83008
			*See note.		
			*NOTE: Production runs were made using an 83009 speaker of 6 ohms impedance at 400 C.P.S. In those cases, T1 was 2500 to 6 ohm output, Part No. 89433.		

MODELS 52-540, 52-540-1, 52-541, 52-541-1, 52-542-1



MODEL 52-540



MODEL 52-541

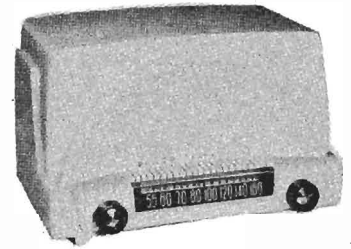

MODEL 52-542-1

SPECIFICATIONS

CABINET

Model 52-540	Phenolic, mottled mahogany
Model 52-540-1	Phenolic, ivory
Model 52-541	Phenolic, mottled mahogany
Model 52-541-1	Phenolic, ivory
Model 52-542-1	Phenolic, ivory

CIRCUIT	5-tube superheterodyne
FREQUENCY RANGE	540—1630 kc.
AUDIO OUTPUT	1.2 watts
OPERATING VOLTAGE	105—125 volts, a.c. or d.c.
POWER CONSUMPTION	30 watts
AERIAL	High-impedance loop; connector for external aerial
INTERMEDIATE FREQUENCY	455 kc.
PHILCO TUBES (5)	7A8, 12BA6, 12AV6, 50L6GT, 35Z5GT

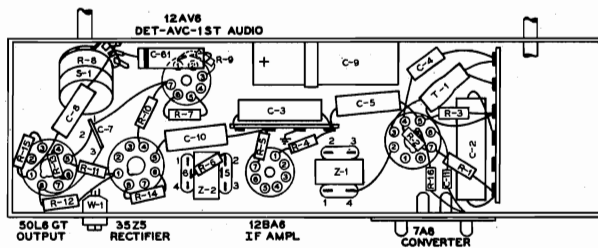

TP1-1136

Figure 1. Symbolized Chassis, Showing Parts Placement

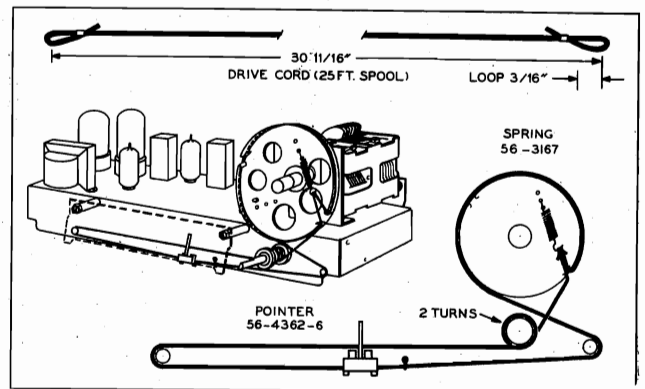

TP-7865F-1

Figure 2. Drive-Cord Installation Details, Models 52-540 and 52-540-1

MODEL 52-541, CODE 123

Changes to parts list:

Backplate	76-7556
Springs, diffusion panel (2)	56-3587-1

The position of the pilot-lamp socket and mounting clip was changed from under the speaker to about center of the front side of the sub-base.

MODELS 52-540, 52-540-1, 52-541, 52-541-1, 52-542-1

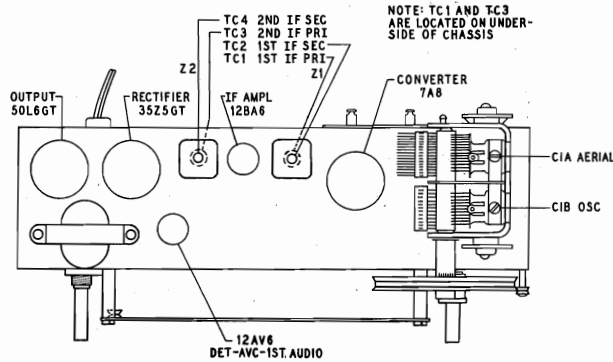

TP1-1130

Figure 3. Top View, Showing Trimmer Locations

ALIGNMENT PROCEDURE

CONTROLS: Turn on radio and set volume control to maximum.

DIAL POINTER: Turn tuning condenser to full-mesh position. Set dial pointer to index mark, located to left of "55."

OUTPUT METER: Connect across voice-coil terminals.

SIGNAL GENERATOR: Connect as indicated in chart. Use modulated output.

OUTPUT LEVEL: During alignment, attenuate signal-generator output to maintain output-meter indication below 1.25 volts.

STEP	SIGNAL GENERATOR		RADIO		ADJUST
	CONNECTION TO RADIO	DIAL SETTING	DIAL SETTING	SPECIAL INSTRUCTIONS	
1	Ground lead to B—; output lead through .1-uf. condenser to pin 6 of 7A8 converter.	455 kc.	540 kc. (gang fully meshed)	Adjust tuning cores, in order given, for maximum output.	TC4—2nd i-f sec. TC3—2nd i-f pri. TC2—1st i-f sec. TC1—1st i-f pri.
2	Radiating loop; see note below.	1600 kc.	1600 kc.	Adjust trimmer for maximum output.	C1B—osc.
3	Same as step 2.	1500 kc.	1500 kc.	Adjust trimmer for maximum output.	C1A—aerial

RADIATING LOOP: Make up a 6—8 turn, 6-inch-diameter loop from insulated wire; connect to signal-generator leads and place near radio loop antenna.

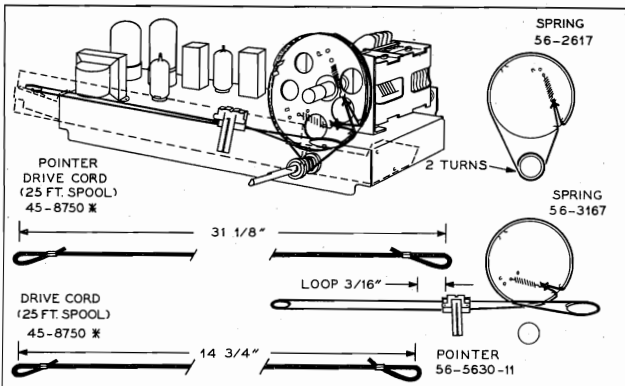

TP-7865E-1

Figure 5. Drive-Cord Installation Details, Model 52-542-1

Figure 4. Drive-Cord Installation Details, Models 52-541 and 52-541-1

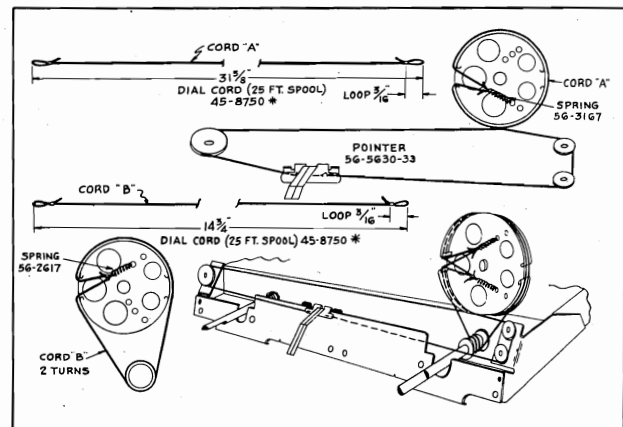

TP1-1131

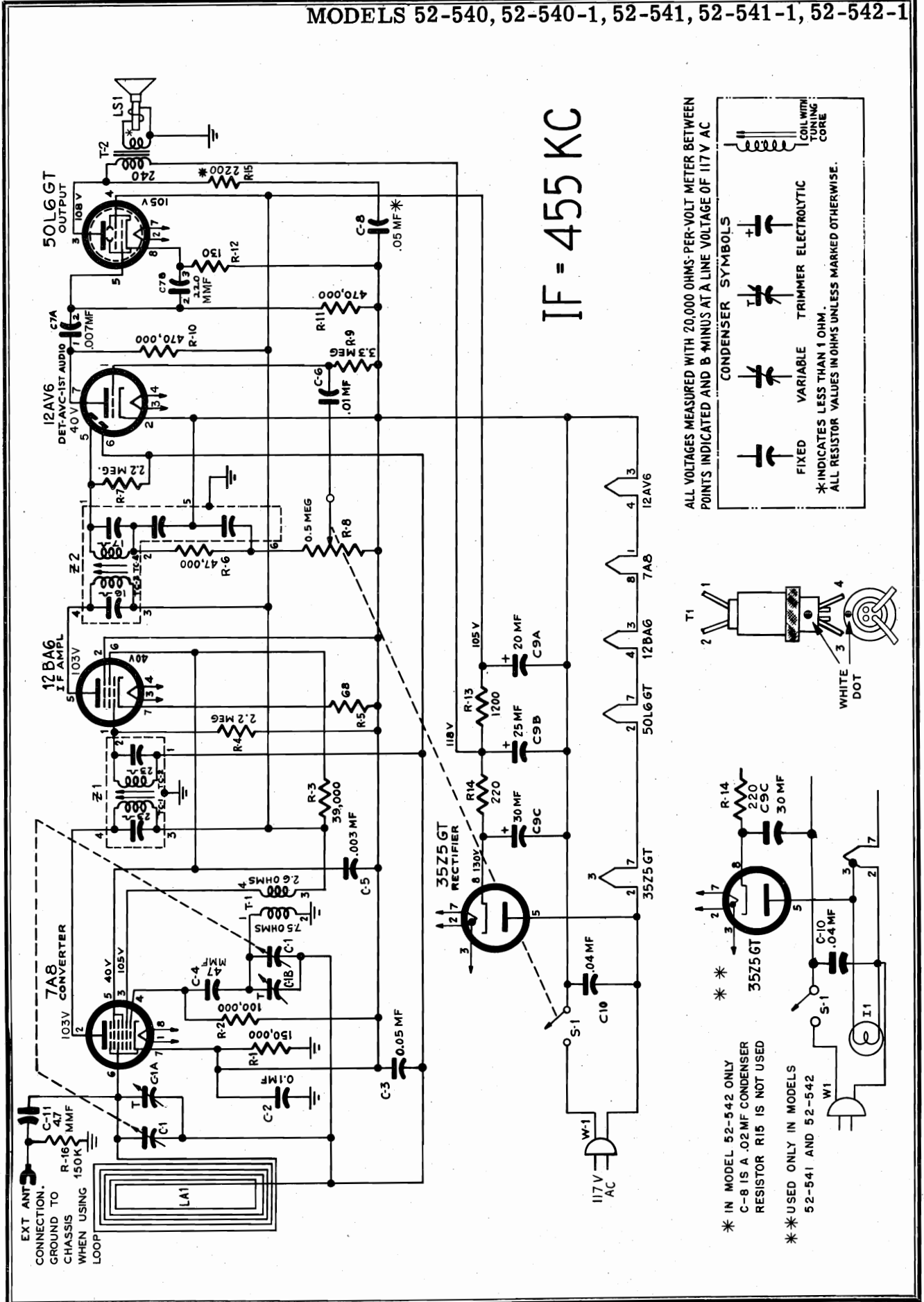

IF = 455 KC

ALL VOLTAGES MEASURED WITH 20,000 OHMS-PER-VOLT METER BETWEEN POINTS INDICATED AND B-MINUS AT A LINE VOLTAGE OF 117V AC

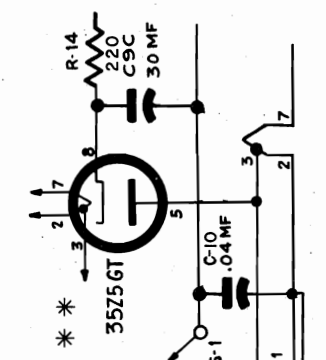
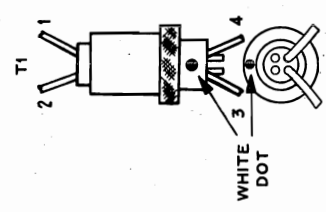
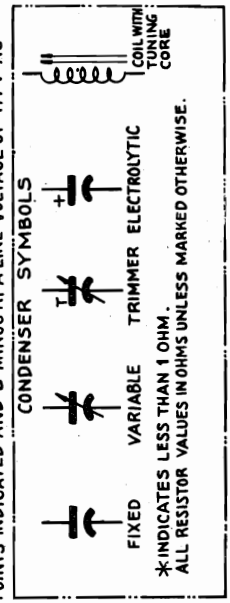

* IN MODEL 52-542 ONLY
C-8 IS A .02 MF CONDENSER
RESISTOR R15 IS NOT USED

* USED ONLY IN MODELS
52-541 AND 52-542

PARTS LIST

NOTE: Part numbers identified by an asterisk (*) are general replacement items. These numbers may not be identical with those on factory parts. Also, the electrical values of some replacement items may differ from the values indicated in the schematic diagram and parts list. The values substituted in any case are so chosen that the operation will be either unchanged or improved. When ordering replacements, use only the "Service Part No."

Reference Symbol	Description	Service Part No.	MISCELLANEOUS	
			Description	Service Part No.
C1	Condenser, tuning gang		MODELS 52-540 AND 52-540-1	
	Model 52-540	31-2751-6	Cabinet, mottled mahogany	10750
	Models 52-541 and 52-542	31-2751	Cabinet, ivory	10750-1
C2	Condenser, i-f bypass, .1 μ f.	61-0113*	Back	54-7777
C3	Condenser, a-v-c by-pass, .05 μ f.	61-0122*	Fastener, back mounting (4)	W2235-2FA9
C4	Condenser, d-c blocking, 47 μ f.	60-00475417*	Baffle, speaker	54-7761
C5	Condenser, screen by-pass, .003 μ f.	61-0109*	Dial-backplate assembly	76-4658
C6	Condenser, d-c blocking, .01 μ f.	61-0120*	Knob (2)	54-4527-11
C7	Condenser, dual ceramic	30-1239-4	Mount, rubber (3)	27-4771-1
C7A	Condenser, d-c blocking, .007 μ f.	Part of C7	Pointer	56-4362-6
C7B	Condenser, grid by-pass, 220 μ f.	Part of C7	Pulley-and-shaft assembly	76-3671-3
C8	Condenser, tone compensation		MODELS 52-541 AND 52-541-1	
	Models 52-540 and 52-541: .05 μ f.	61-0122*	Cabinet, mahogany	10747
	Model 52-542: .02 μ f.	61-0108*	Knob (2)	54-4674
C9	Condenser, electrolytic, 3-section	30-2573	Cabinet, ivory	10747-1
C9A	Condenser, filter, 20 μ f., 150v	Part of C9	Knob (2)	54-4674-1
C9B	Condenser, filter, 25 μ f., 150v	Part of C9	Back	54-7767
C9C	Condenser filter, 30 μ f., 150v	Part of C9	Fastener, back mounting (4)	W2235FA9
C10	Condenser, line by-pass, .04 μ f.	45-3500-2*	Baffle, speaker	54-7761
C11	Condenser, external-aerial coupling, 4.7 μ f.	30-1230	Backplate, bracket and pulley assembly	76-6235
II	Pilot lamp (Models 52-541 and 52-542-1 only)	34-2068	Dial-backplate assembly	76-4570
LA1	Loop aerial		Fastener, pilot-lamp shield mounting (2)	W2235-1FA9
	Models 52-540 and 52-540-I	32-4052-33	Speed clip, grille mounting (4)	1W56920FE7
	Models 52-541 and 52-541-I	32-4052-31	Jewel	54-4304
	Model 52-542-I	32-4052-38	Mount, rubber (3)	27-4771-1
LS1	Speaker, p-m		Pointer <i>54-5630-11 Code 123, 56-4774-2, F.C.P.</i>	
	Models 52-540, 52-540-I, 52-541 and 52-541-I	36-1627-5	Spring, pointer drive	56-3167
	Model 52-542-I	36-1625-3	Pulley-and-shaft assembly	76-3671-2
R1	Resistor, leakage, 150,000 ohms	66-4158340*	Scale strap, dial mounting	
R2	Resistor, grid return, 100,000 ohms	66-4108340*	LH	56-7373
R3	Resistor, screen dropping, 39,000 ohms	66-3398340*	RH	56-7373-1
R4	Resistor, grid return, 2.2 megohms	66-5228340*	Socket assembly, pilot lamp	27-6233-6
R5	Resistor, cathode bias, 68 ohms	66-0688340*	MODEL 52-542-I	
R6	Resistor, i-f filter, 47,000 ohms	66-3478340*	Cabinet, ivory	10769-8
R7	Resistor, diode load, 2.2 megohms	66-5228340*	Back	5479-11
R8	Volume control, 500,000 ohms		Fastener, back mounting (4)	W2235FA9
	Models 52-540 and 52-540-I	33-5538-7	Clips, baffle mounting	1W56920FE7
	Models 52-541 and 52-541-I	33-5566-4	Baffle, speaker	54-7761
	Model 52-542-I	33-5566-4	Dial scale	54-5104
R9	Resistor, grid return, 3.3 megohms	66-5338340*	Screw, scale mounting (2)	1W14504FA1
R10	Resistor, plate load, 470,000 ohms	66-4478340*	Dial-backplate assembly	54-4929
R11	Resistor, grid return, 470,000 ohms	66-4478340*	Knob (2)	54-4718-33
R12	Resistor, cathode bias, 130 ohms	66-1133260*	Backplate, bracket-and-pulley assembly	76-7048
R13	Resistor, filter, 1200 ohms	66-2128340*	Fastener, pilot-lamp shield mounting (2)	W2235-1FA9
R14	Resistor, filter, 220 ohms, 1 watt	66-1224340*	Grille, plastic	54-4919-1
R15	Resistor, tone compensation, 2200 ohms (Models 52-540, 52-540-I, 52-541 and 52-541-I only)	66-2228340	Mount, rubber (3)	27-4771-1
R16	Resistor, aerial isolating, 150,000 ohms	66-4158340	Pointer	56-5630-33
S1	Switch, off-on	Part of R8	Spring, pointer drive	56-3167
T1	Transformer, oscillator	32-4263	Pulley-and-shaft assembly	76-3671-2
T2	Transformer, output	32-8384	Socket assembly, pilot lamp	27-6233-6
W1	Line cord	L-2183*	PARTS COMMON TO ALL MODELS	
Z1	Transformer, st i-f	32-4160-6A	Bushing, pulley and shaft	27-9437
Z2	Transformer, 2nd i-f	32-4240-A	Clamp, electrolytic mounting	56-1466
			Drive cord, 25-foot spool	45-8750*
			Fastener, hairpin, pulley and shaft	57-1468FA3
			Socket, Loktal (1)	27-6269
			Socket, miniature (2)	27-6265
			Socket, octal (2)	27-6174
			Spring, gang drive	56-2617

MODELS 52-544,
52-544-I, 52-544-W



MODEL 52-544-I

SPECIFICATIONS

CABINET

Model 52-544	Molded phenolic, mahogany	OPERATING VOLTAGE	117 volts, a-c.
Model 52-544-I	Molded phenolic, ivory	POWER CONSUMPTION	30 watts
Model 52-544-W	Molded phenolic, white	AERIAL	High-impedance loop; connector for external aerial
FREQUENCY RANGE	540—1600 kc.	INTERMEDIATE FREQUENCY	455 kc.
AUDIO OUTPUT	1 watt	PHILCO TUBES (5)	7A8, 12BA6, 12AV6, 50L6GT, 35Z5

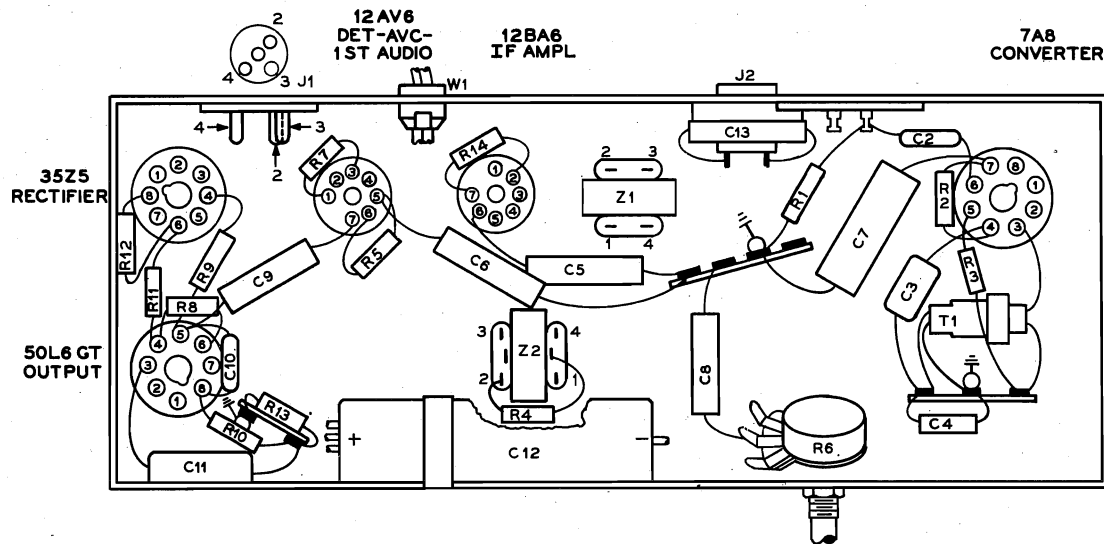

Figure 1. Base View, Showing Symbolized Chassis

TP1-1139

MODELS 52-544,
52-544-I, 52-544-W

ALIGNMENT PROCEDURE

RADIO CONTROLS — Set volume control to maximum. Set tuning control as indicated in chart.

OUTPUT METER — Connect across voice-coil terminals.

SIGNAL GENERATOR — Connect generator and set frequency as indicated in chart. Use modulated output.

OUTPUT LEVEL — During alignment, adjust signal-generator output to hold output-meter reading below 1.25 volts.

STEP	SIGNAL GENERATOR		RADIO		ADJUST
	CONNECTION TO RADIO	DIAL SETTING	DIAL SETTING	SPECIAL INSTRUCTIONS	
1	Connect ground lead to B—; output lead through .1- μ f. condenser to grid (pin 6) of 7A8.	455 kc.	Tuning condenser fully meshed.	Adjust tuning cores, in order given, for maximum output.	TC4—2nd i-f sec. TC3—2nd i-f pri. TC2—1st i-f sec. TC1—1st i-f pri.
2	Radiating loop (see note below).	1600 kc.	1600 kc.	Adjust trimmer for maximum output.	C1B—Osc.
3	Same as step 2.	1500 kc.	1500 kc.	Adjust trimmer for maximum output.	C1A—Aerial

RADIATING LOOP: Make up a 6–8 turn, 6-inch-diameter loop, from insulated wire; connect to signal-generator leads and place near radio loop aerial.

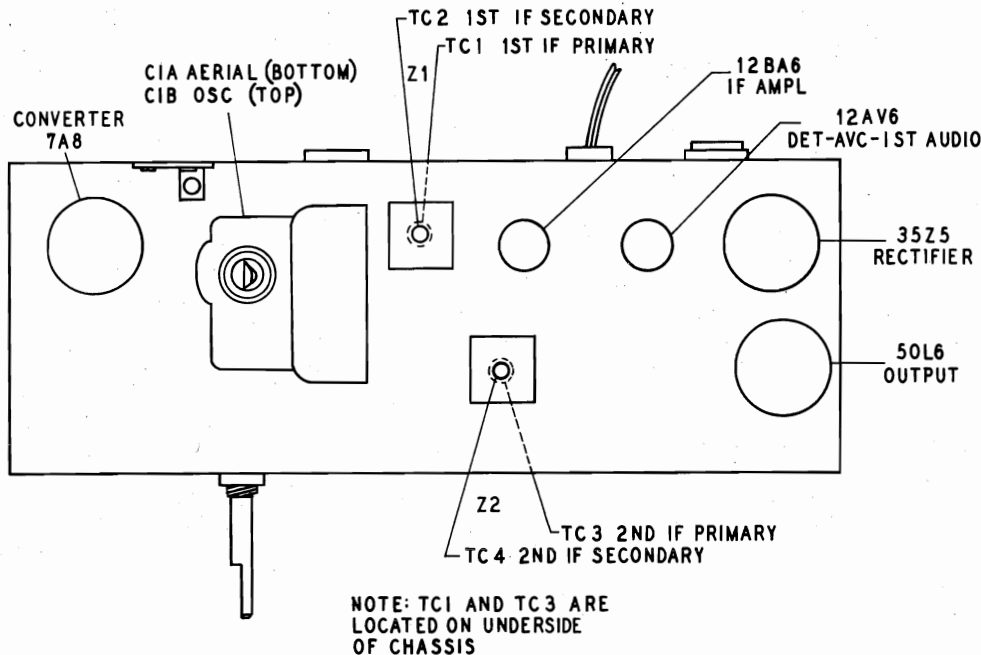

Figure 2. Top View, Showing Trimmer Locations

TP1-1140

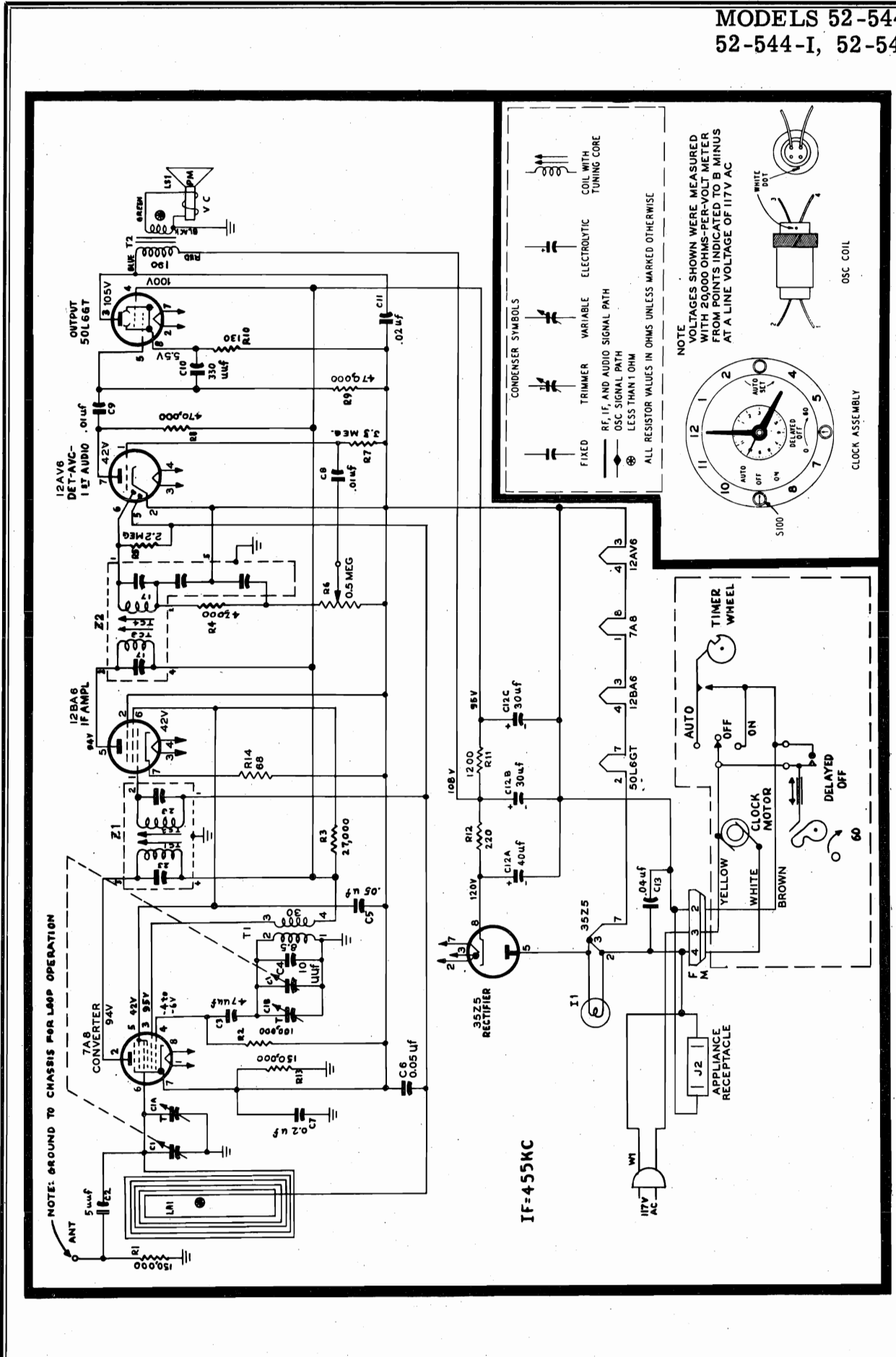

Figure 3. Philco Radio-Clock Models 52-544, 52-544-I and 52-544-W, Schematic Diagram

TP1-1141

MODELS 52-544,
52-544-I, 52-544-W

PARTS LIST

NOTE: Part numbers marked with an asterisk (*) are general replacement items. These numbers may not be identical with those on factory parts; also, the electrical values of some replacement items may differ from the values indicated in the schematic diagram and parts list. The values substituted in any case are so chosen that the operation of the radio will be either unchanged or improved. When ordering replacements, use only the "Service Part No."

Reference Symbol	Description	Service Part No.	MISCELLANEOUS	
C1	Condenser, tuning gang, 2-section	31-2751-5	Description	Service Part No.
C1A	Condenser, trimmer, aerial	Part of C1	Cabinet	
C1B	Condenser, trimmer, oscillator	Part of C1	MODEL 52-544	10745
C2	Condenser, aerial coupling, 5 μ f.	30-1230	MODEL 51-544-I	10745-1
C3	Condenser, d-c blocking, 47 μ f.	60-00475417*	MODEL 52-544-W	10745-4
C4	Condenser, temperature compensating, 7.5 μ f.	30-1224-65	Back	54-8391
C5	Condenser, screen by-pass, .05 μ f.	61-0122*	Fastener (4), back mounting	W2235FA9
C6	Condenser, a-v-c by-pass, .05 μ f.	61-0122*	Baffle-and-cloth assembly	
C7	Condenser, by-pass, .2 μ f.	45-3500-3*	Model 52-544	40-7730
C8	Condenser, d-c blocking, .01 μ f.	45-3505-58	Model 52-544-I	40-7730-1
C9	Condenser, d-c blocking, .01 μ f.	45-3505-58	Model 52-544-W	40-7730-2
C10	Condenser, parasitic suppressor, 330 μ f.	60-10335417*	Jewel (used on mahogany and ivory cabinets)	54-4304
C11	Condenser, tone compensation, .02 μ f.	61-0108*	Jewel (used on white cabinet only)	54-4304-1
C12	Condenser, electrolytic, 3-section	30-2575-27	Knobs	
C12A	Condenser, filter, 30 μ f., 150v	Part of C12	MODEL 52-544	
C12B	Condenser, filter, 25 μ f., 150v	Part of C12	VOLUME	27-4820
C12C	Condenser, filter, 20 μ f., 150v	Part of C12	AUTO-OFF-ON	
C13	Condenser, line filter, .04 μ f.	45-3500-2*	DELAYED OFF	54-4736
I1	Pilot lamp	34-2068	AUTO SET	54-4736-2
J1	Socket, clock motor and switch	27-6273	TIME SET	54-4736-4
J2	Receptacle, appliance, a-c	76-3931	MODEL 52-544-I	
LA1	Loop aerial	32-4052-32	VOLUME	54-4118
LS1	Speaker, p-m	36-1627-8	AUTO-OFF-ON	
R1	Resistor, isolating, 150,000 ohms	66-4158340*	DELAYED OFF	54-4736-1
R2	Resistor, grid return, 100,000 ohms	66-4108340*	AUTO SET	54-4736-3
R3	Resistor, screen dropping, 27,000 ohms	66-3278340*	TIME SET	54-4736-4
R4	Resistor i-f filter 47,000 ohms	66-3478340*	MODEL 52-544-W	
R5	Resistor, diode load, 2.2 megohms	66-5228340*	VOLUME	27-4817-7
R6	Volume control, 500,000 ohms	33-5565-6	AUTO-OFF-ON	
R7	Resistor, grid return, 3.3 megohms	66-5338340*	DELAYED OFF	54-4736-5
R8	Resistor, plate load, 470,000 ohms	66-4478340*	AUTO SET	54-4736-6
R9	Resistor, grid return, 470,000 ohms	66-4478340*	TIME SET	54-4736-7
R10	Resistor, cathode bias, 130 ohms	66-1138340*	Clamp, electrolytic mounting	56-1466
R11	Resistor, filter, 1200 ohms	66-2128340*	Clip, pilot-lamp mounting	56-3545-6FA3
R12	Resistor, filter, 220 ohms, 1 watt	66-1224340*	Clock-and-cable assembly	
R13	Resistor, leakage, 150,000 ohms	66-4158340*	MODEL 52-544, 60-cycle	76-6723
R14	Resistor, cathode bias, 68 ohms	66-0688340	MODEL 52-544-I, 60-cycle	76-6724
S1	Switch, AUTO-OFF-ON	Part of clock assembly	MODEL 52-544-W, 60-cycle	76-6725
T1	Transformer, oscillator	32-4263	Clock cover	56-6710
T2	Transformer, output	Part of LS1	Dial scale, mahogany and ivory	54-5055-2
W1	Line cord	L-2183*	Dial scale, white	54-5055-4
Z1	Transformer, 1st i-f	32-4160-6A	Lead assembly, aerial	76-1472
Z2	Transformer, 2nd i-f	32-4240A	Mount, rubber, gang mounting (3)	27-4771-1
			Shield, pilot lamp	56-9074-3
			Socket, clock	27-6273-7
			Socket, Loktal (1)	27-6269
			Socket, octal (2)	27-6174
			Socket, miniature (1)	27-6265
			Socket assembly, pilot lamp	27-6233-6

MODELS 52-543,
52-545, 52-547, 52-550



MODELS 52-543* AND 52-545

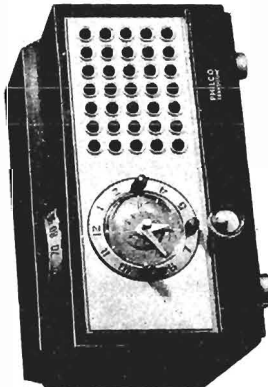

MODEL 52-547

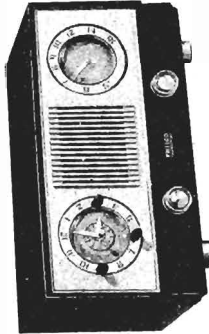

MODEL 52-550

SPECIFICATIONS

FREQUENCY RANGE540—1600 kc. AERIAL High-impedance loop; connector for external aerial

AUDIO OUTPUT 1 watt INTERMEDIATE FREQUENCY455 kc.

OPERATING VOLTAGE117 volts, a.c. PHILCO TUBES (5)7A8, 12BA6, 12AV6, 35L6GT, 35Z5

POWER CONSUMPTION30 watts

*The clock of Model 52-543 has TIME SET control only.

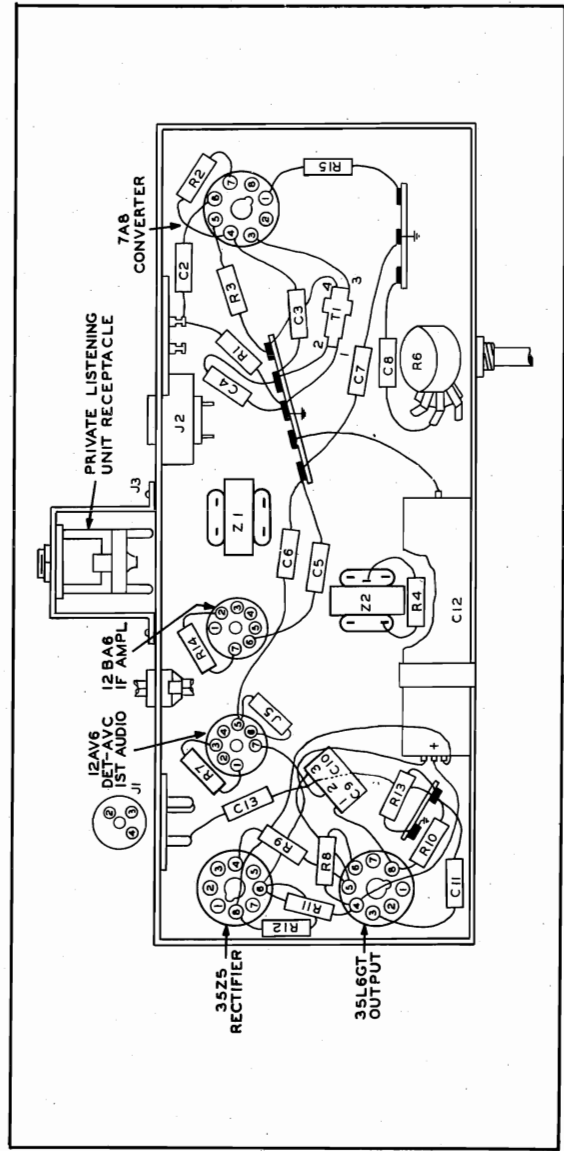

TP2-1326

Figure 1. Model 52-550, Base View, Showing Symbolized Chassis

MODELS 52-543, -545, -547, -550

PRELIMINARY INFORMATION

Models 52-543, 52-545, 52-547, and 52-550 are electrically similar to Model 52-544, but they are housed in different style cabinets, and incorporate certain circuit refinements over Model 52-544.

The following diagrams and the Service Information and Parts List given on page 12 of this Service Manual are for Models 52-543, 52-545, 52-547, and 52-550 only. For Alignment Procedure and the basic Schematic Diagram and Parts List for all models, refer to 52-544.

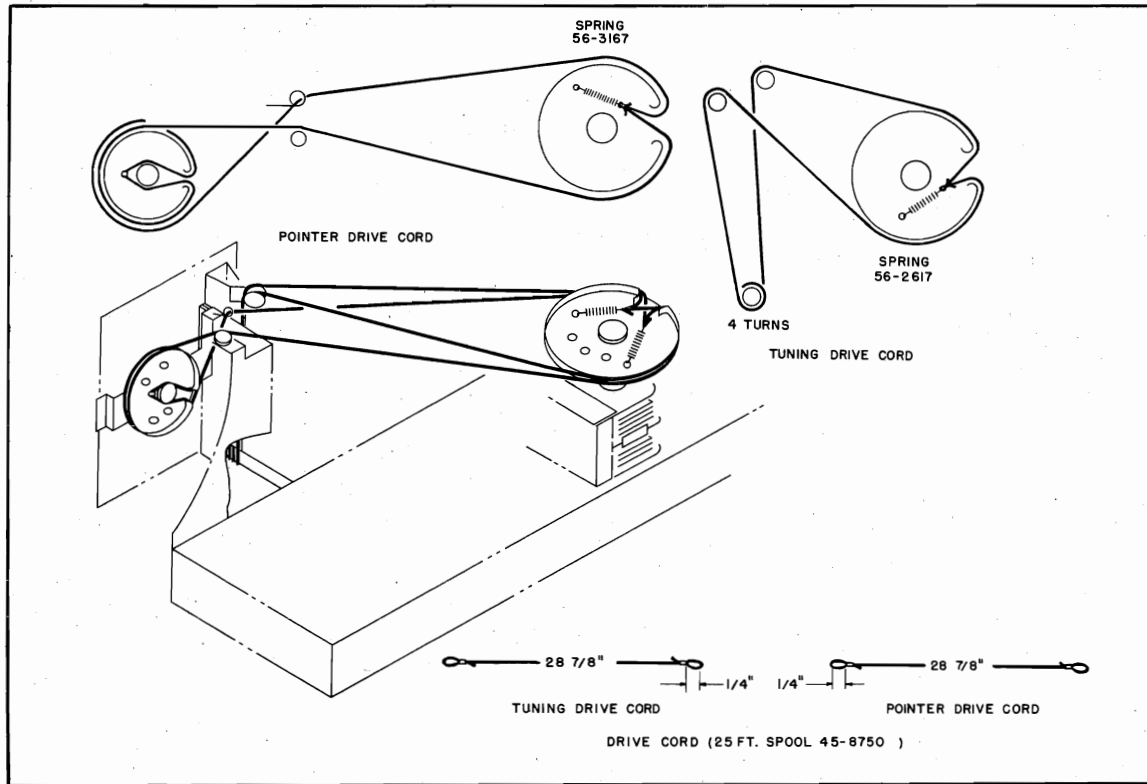

Figure 2. Model 52-550, Drive-Cord Installation Details

TP2-1325

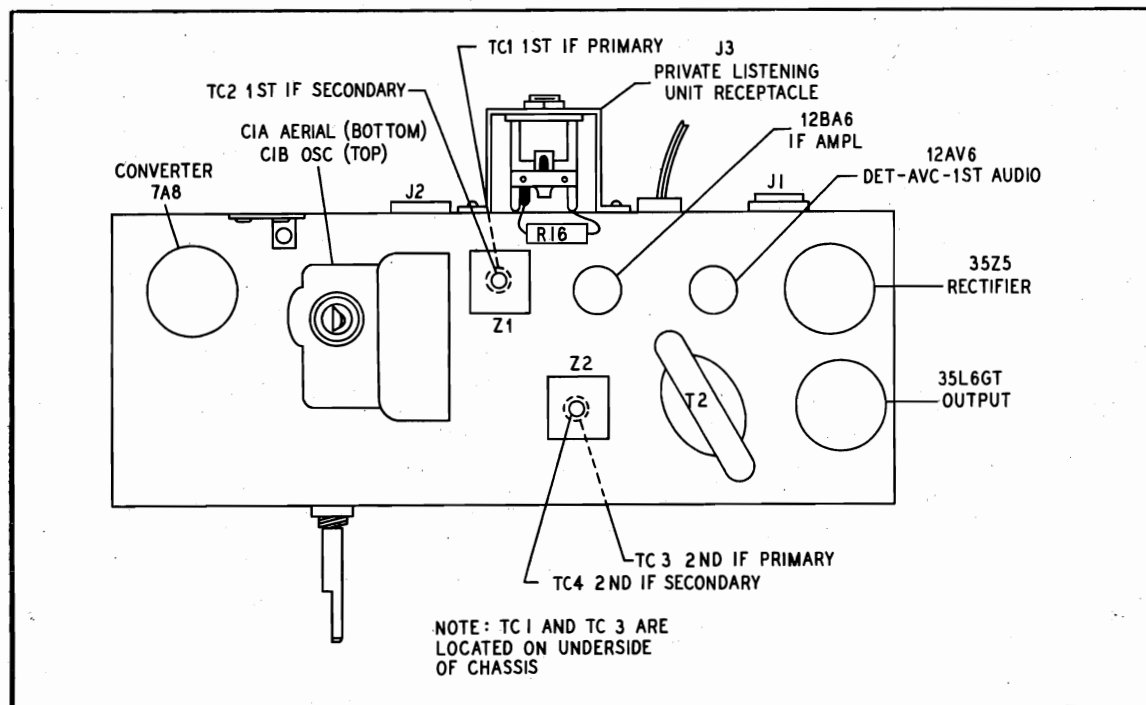

Figure 3. Model 52-550, Top View, Showing Trimmer Locations

TP2-1327

MODELS 52-543,
52-545, 5-2547, 52-550

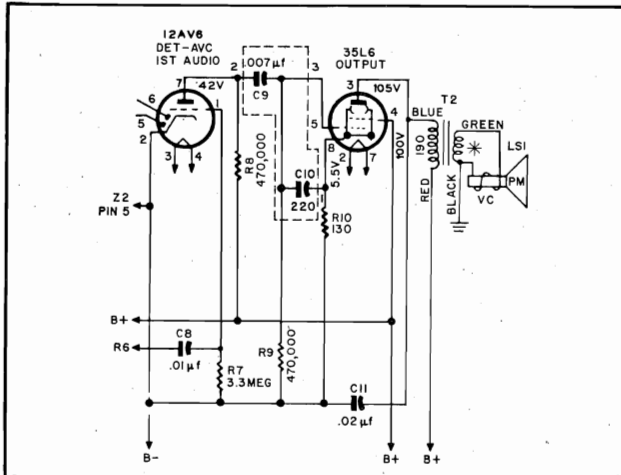

Figure 4. Models 52-543, 52-545, and 52-547, Output Circuit TP2-1335

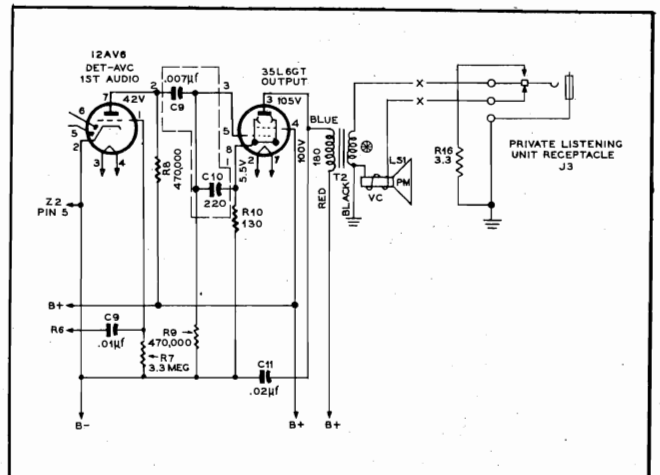

Figure 5. Model 52-550, Output Circuit TP2-1336

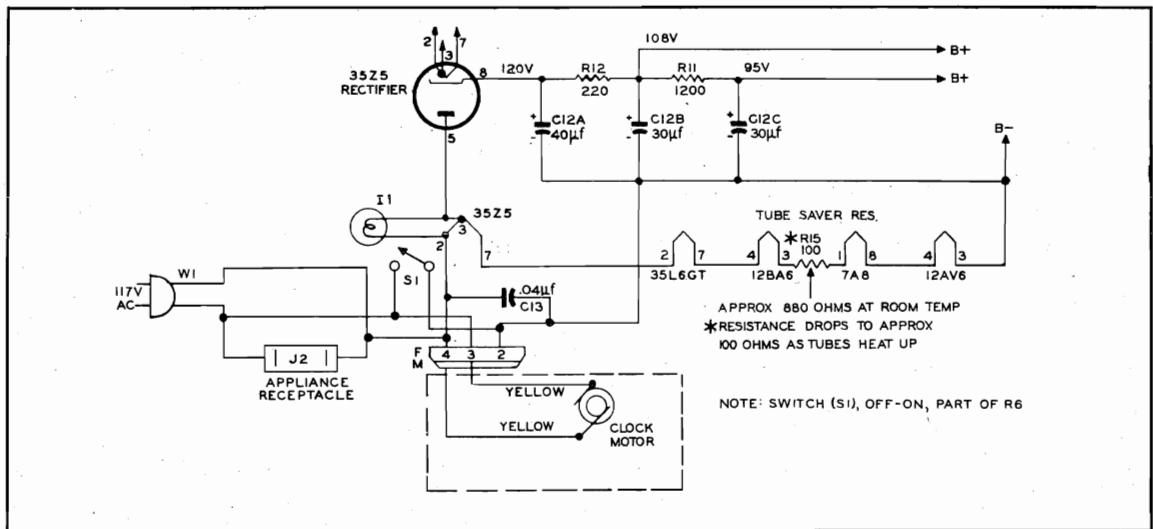

Figure 6. Model 52-543, Power and Clock Circuits TP2-1337

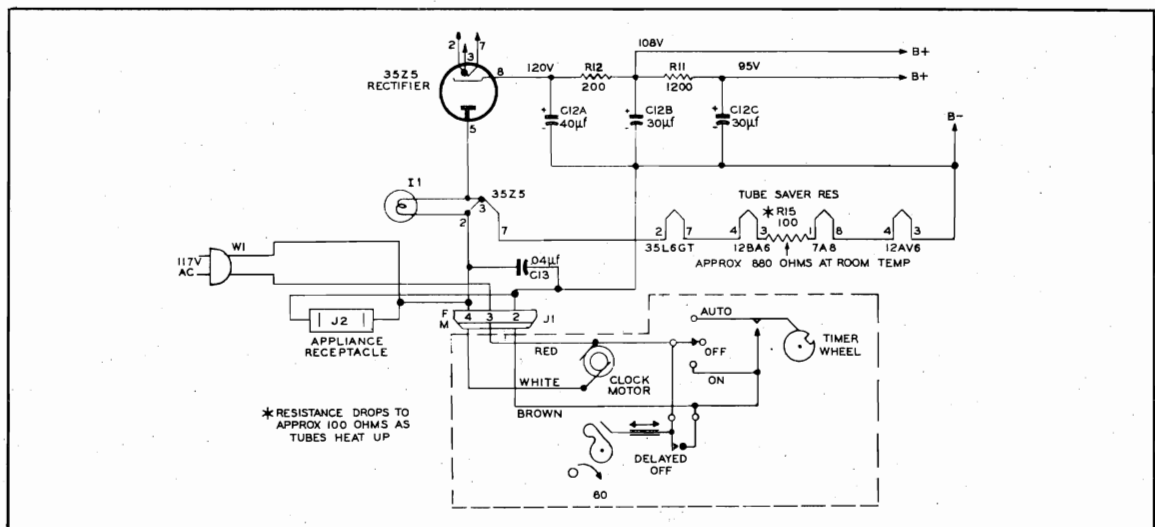

Figure 7. Models 52-545, 52-547, and 52-550, Power and Clock Circuits TP2-1338

MODELS 52-543,
52-545, 52-547, 52-550

SERVICE INFORMATION

MODELS 52-543, 52-545, 52-547, AND 52-550

Dual condenser, C9 and C10, Part No. 30-1239-4, used for audio coupling (.007 μ f.) and grid by-pass (220 μ f.) respectively. Output tube changed from 50L6GT to a 35L6GT.

Isolating condenser, C7, Part No. 61-0113; from 7A8 converter-tube cathode to ground, was changed from a .2 μ f. condenser to a .1 μ f. condenser.

MODELS 52-543, 52-545, AND 52-547

Pilot light and bracket are mounted on rear of clock cover.

MODEL 52-543

Clock is nonautomatic; has TIME SET control only.

Appliance receptacle on rear of chassis is connected directly to a-c line. Appliance capacity is 1100 watts. OFF-ON switch is part of VOLUME control, R6.

MODEL 52-547

Loop assembly, LA1, is Part No. 32-4052-64.

MODEL 52-550

Included with this model is Philco Private Listening unit receptacle, J3, Part No. 42-1975-2. A shunt resistor, R16, has been provided from J3 to ground. This shunt resistor reduces volume to level required for Private Listening. R16 is a 3.3-ohm resistor, Part No. 66-9334540.

Loop assembly, LA1, is Part No. 32-4052-64. Speaker, p.m., LS1, is Part No. 36-1627-11.

PARTS LIST

FOR MODELS 52-543, 52-545, 52-547, AND 52-550

For all parts not listed in this Service Manual, refer to *Page 8*.

MISCELLANEOUS

Description	Service Part No.	Description	Service Part No.
Cabinet		TIME SET	54-4736-11
Models 52-543M and 52-545M	10745-9	VOLUME	54-4773
Model 52-5451	10745-10	Models 52-550M and 550L	
Model 52-547L	10908-1	AUTO SET	54-4736-10
Model 52-547M	10908	AUTO-OFF-ON	54-4736-9
Model 52-550L	10907-1	DELAYED OFF	54-4736-9
Model 52-550M	10907	TUNING	54-4718-6
Back, cabinet		TIME SET	54-4736-11
Models 52-543M, 52-545M, and 52-5451	54-8391	VOLUME	54-4718-6
Models 52-547L and 52-547M	54-8634	Bracket-and-pulley assembly	
Models 52-550L and 52-550M	54-8637	Models 52-550M and 52-550L	76-7580
Baffle-and-cloth assembly		Clock cover-and-clip assembly	
Models 52-543M and 52-545M	40-7730	Models 52-543M, 52-545M and 52-5451	76-7547
Model 52-5451	40-7730-1	Models 52-547M and 52-547L	76-7638
Knobs		Models 52-550M and 52-550L	76-7625
Model 52-543M		Clock and plug assembly	
DIAL SCALE	54-5055-5	Model 52-543M	76-7559
TIME SET	56-9656	Models 52-545M, 52-5451, 52-547M, and 52-547L	76-7544
VOLUME-OFF-ON	27-4815-9	Models 52-550M and 52-550L	76-7596
Models 52-545M and 52-5451		Dial-and-backplate assembly	
AUTO SET	54-4736-10	Models 52-550M and 52-550L	76-7579
AUTO-OFF-ON	54-4736-9	Socket, clock	
DELAYED OFF	54-4736-9	Models 52-543M, 52-545M, 52-5451, 52-547M, and 52-547L	27-6273
DIAL SCALE	54-5055-5	Models 52-550M and 52-550L	27-6273
TIME SET	54-4736-11	Plug, clock	54-4878-2
VOLUME	27-4815-9	Tuning shaft	56-9659
Models 52-547M and 52-547L		Shaft assembly, pointer	76-7581
AUTO SET	54-4736-10		
AUTO-OFF-ON	54-4736-9		
DELAYED OFF	54-4736-9		
DIAL SCALE	54-5055-5		

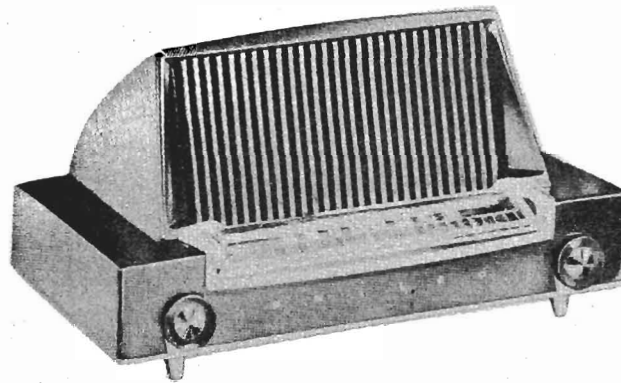

TPI-1843

MODEL 52-548

SPECIFICATIONS

CABINET	Molded plastic, maroon	INTERMEDIATE FREQUENCY	455 kc.
CIRCUIT	Four-tube superheterodyne plus rectifier	AERIAL	Magnecor high-impedance loop; provision for connecting external aerial
FREQUENCY RANGE	540—1620 kc.	PHILCO TUBES	7A8 converter, 7B7 i-f amplifier, 7C6 2nd det., avc., 1st audio, 50C5 output, 35W4 rectifier
AUDIO OUTPUT	1 watt		
OPERATING VOLTAGE	105—120 volts, a.c. or d.c.		
POWER CONSUMPTION	30 watts		

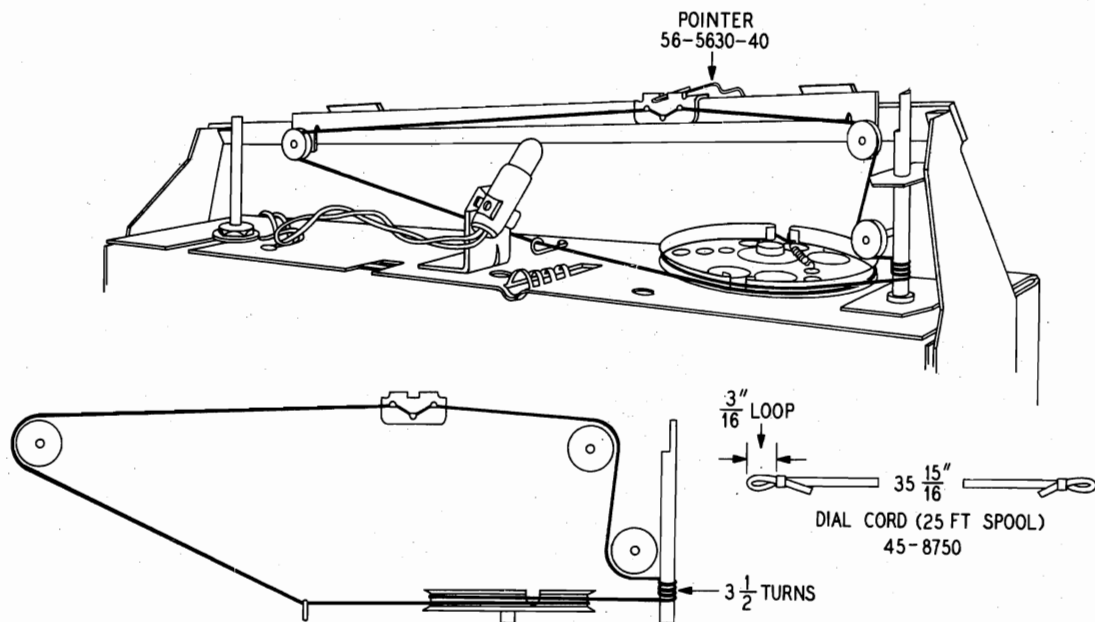

Figure 1. Drive-Cord Installation Details

TPI-1839

ALIGNMENT PROCEDURE

DIAL POINTER—Turn tuning condenser to full-mesh position. Set dial pointer to index mark, located to the left of "55".

CONTROLS—Set volume control to maximum, and tuning control as indicated in chart.

OUTPUT METER—Connect across voice-coil terminals.

SIGNAL GENERATOR—Ground lead to B—, output lead as indicated in chart.

OUTPUT LEVEL—During alignment, attenuate signal-generator output to hold output-meter indication below 1.25 volts.

STEP	SIGNAL GENERATOR		RADIO		ADJUST TRIMMER
	CONNECTION TO RADIO	DIAL SETTING	DIAL SETTING	SPECIAL INSTRUCTIONS	
1	Through a .01- μ f. condenser to pin 6 of 7A8 converter tube.	455 kc.	Gang fully open.	Adjust, in order given, for maximum output. TC1 and TC4 are located at top of transformers.	TC4—2nd i-f sec. TC3—2nd i-f pri. TC2—1st i-f sec. TC1—1st i-f pri.
2	Radiating loop (see note below).	1600 kc.	1600 kc.	Adjust for maximum.	C1B—osc. trimmer
3	Same as step 2.	1500 kc.	1500 kc.	Adjust for maximum.	C1A—ant. trimmer

RADIATING LOOP: Make up a 6—8-turn, 8-inch-diameter loop from insulated wire, connect to signal generator output leads, and place near radio loop.

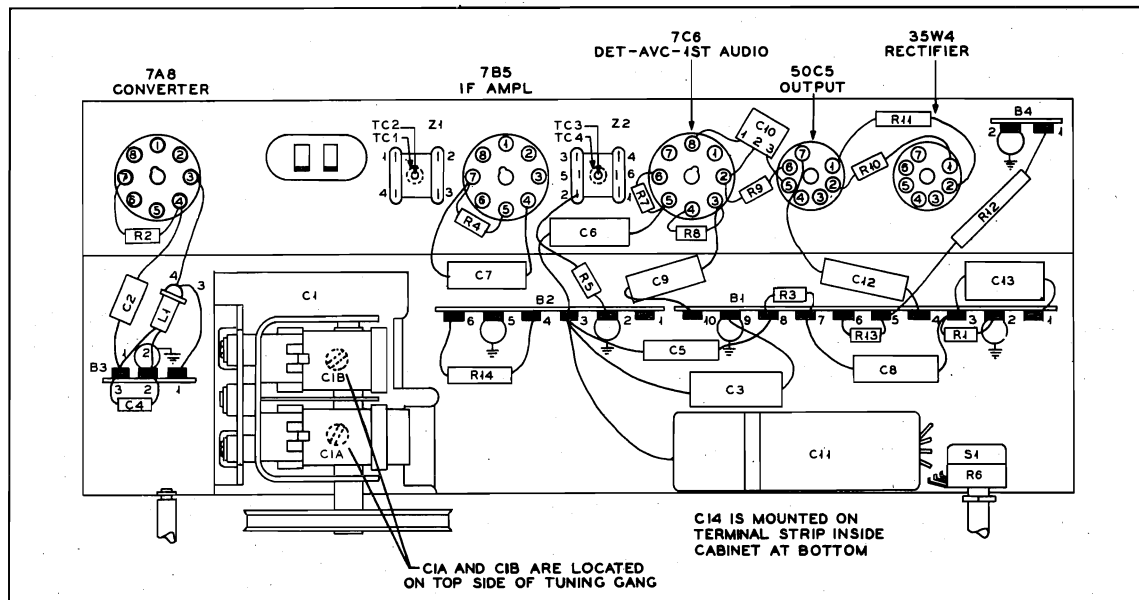

Figure 2. Base View, Showing Parts Placement and Alignment Points

TPI-1840

PARTS LIST

NOTE: Part numbers identified by an asterisk (*) are general replacement items. These numbers may not be identical with those on factory parts; also, the electrical values of some replacement items may differ from the values indicated in the schematic diagram and parts list. The values substituted in any case are so chosen that the operation of the radio will be either unchanged or improved. When ordering replacements, use only the "Service Part No."

Reference Symbol	Description	Service Part No.	Reference Symbol	Description	Service Part No.
C1	Condenser, tuning gang	31-2751-10	R7	Resistor, diode load, 2.2 megohms	66-5228340*
C1A	Condenser, trimmer, aerial	Part of C1	R8	Resistor, grid return, 10 megohms	66-6108340*
C1B	Condenser, trimmer, oscillator	Part of C1	R9	Resistor, plate load, 470,000 ohms	66-4478340*
C2	Condenser, osc. grid, d-c blocking, 47 μ f.	60-00475417*	R10	Resistor, grid return, 470,000 ohms	66-4478340*
C3	Condenser, leakage, .1 μ f.	45-3505-47	R11	Resistor, cathode bias, 150 ohms	66-1154340*
C4	Condenser, temperature compensating, 7.5 μ f.	30-1224-65*	R12	Resistor, filter, 220 ohms, 2 watts	66-1225340*
C5	Condenser, screen by-pass, .1 μ f.	61-0113*	R13	Resistor, filter, 1200 ohms	66-2128340*
C6	Condenser, a-v-c by-pass, .1 μ f.	61-0113*	R14	Resistor, surge limiting, 880 ohms cold, 100 ohms hot	33-1343-3
C7	Condenser, cathode by-pass, .05 μ f.	61-0122*	S1	Switch, off-on	Part of R6
C8	Condenser, B+ by-pass, .1 μ f.	45-3505-47*	T1	Transformer, output	32-8384*
C9	Condenser, audio coupling, .01 μ f.	45-3505-58*	W1	Line cord	L2183
C10	Condenser, dual ceramic	30-1239-4	Z1	Transformer, 1st i-f	32-4160A
C10A	Condenser, audio coupling, .007 μ f.	Part of C10	Z2	Transformer, 2nd i-f	32-4240A
C10B	Condenser, grid by-pass, 220 μ f.	Part of C10			
C11	Condenser, electrolytic, 4-section	30-2575-32*			
C11A	Condenser, cathode by-pass, 25 μ f.	Part of C11			
C11B	Condenser, filter, 40 μ f.	Part of C11			
C11C	Condenser, filter, 40 μ f.	Part of C11			
C11D	Condenser, filter, 40 μ f.	Part of C11			
C12	Condenser, tone compensation, .01 μ f.	45-3505-58*			
C13	Condenser, line by-pass, .04 μ f.	30-1226-17*			
C14	Condenser, aerial, fixed trimmer, 10 μ f.	30-1224-26*			
I1	Pilot lamp, type 47	34-2068			
L1	Coil, oscillator	32-4263			
LA1	Loop antenna (Magnecor)	32-4455-6			
LS1	Speaker, 5 1/4" round	36-1639-9			
R1	Resistor, leakage, 150,000 ohms	66-4158340*			
R2	Resistor, grid return, 100,000 ohms	66-4108340*			
R3	Resistor, dropping, 27,000 ohms	66-3278340*			
R4	Resistor, cathode bias, 180 ohms	66-1188340*			
R5	Resistor, i-f filter, 47,000 ohms	66-3478340*			
R6	Resistor, volume control, .5 megohm (with switch)	33-5566-36			

MISCELLANEOUS

Description	Service Part No.
Cabinet	10887
Fastener (5 required)	W2235-1FA9
Knob (2 required)	54-4774-9
Knob escutcheon (2 required)	54-4927
Dial backplate assembly	76-7056
Drive cord, 25-foot spool	45-8750
Dial scale	54-5128
Lamp assembly, pilot	27-6233-18
Pointer	56-5630-40
Shaft, tuning	56-9272
Spring	56-2617
Spring, hairpin	57-1468FA3
Mount, rubber (3 required)	27-4596
Socket, Locktal (3 required)	27-6207
Socket, miniature (2 required)	27-6265

SUPPLEMENT TO MODEL 52-548

Additions to parts list:

Cabinet, ivory	10887-3
Escutcheon, knob (2)	54-4927
Knob (2)	54-4774-10
Scale	54-5128



MODEL 52-640

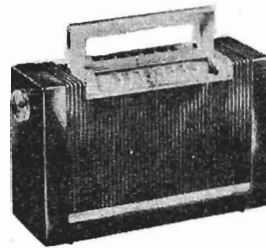

MODEL 52-641

SPECIFICATIONS

- CABINET Plastic, portable
- CIRCUIT Four-tube superheterodyne (plus selenium rectifier)
- FREQUENCY RANGE 540—1620 kc.
- AUDIO OUTPUT
 - A-c or d-c operation 150 milliwatts
 - Battery operation
 - Model 52-640 150 milliwatts
 - Model 52-641 75 milliwatts
- OPERATING VOLTAGES
 - Model 52-640 117 volts, a.c. or d.c.; 1.5-volt "A" and 90-volt "B" battery
 - Model 52-641 117 volts, a.c. or d.c.; 1.5-volt "A" and 67.5-volt "B" battery
- POWER CONSUMPTION
 - A-c or d-c operation 11 watts
 - Battery operation
 - Model 52-640 13 ma. from 90-volt "B" battery; 250 ma. from 1.5-volt "A" battery
 - Model 52-641 9.5 ma. from 67.5-volt "B" battery; 250 ma. from 1.5-volt "A" battery
- AERIAL
 - Model 52-640 High-impedance loop; provision for connecting external aerial
 - Model 52-641 Magnecor high-impedance loop; provision for connecting external aerial
- INTERMEDIATE FREQUENCY 455 kc.
- PHILCO TUBES (4) 1R5 converter, 1U4 i-f ampl., 1U5 det.-a.v.c.-1st audio, 3V4 output
- BATTERY TYPE
 - Model 52-640 P-364
 - Model 52-641 P-67 "B" battery; Type D "A" battery

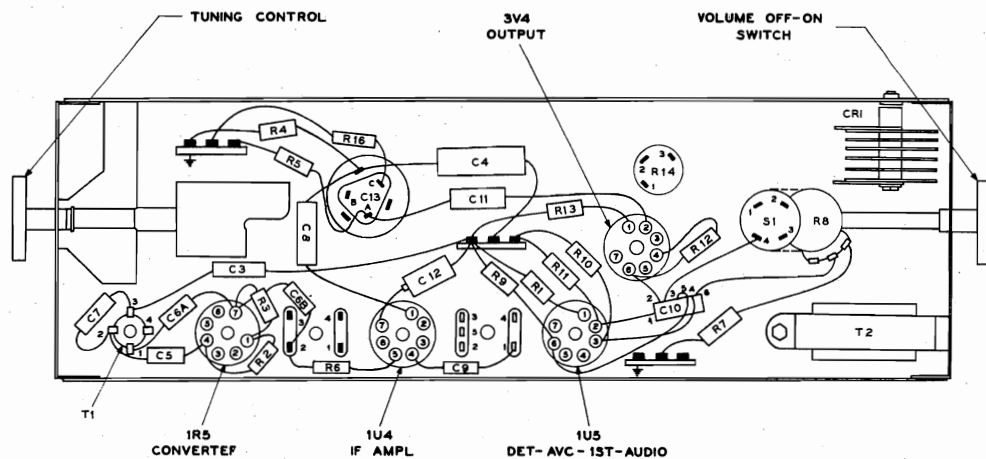

Figure 1. Bottom View, Showing Symbolized Chassis

TP1-1167

ALIGNMENT PROCEDURE

DIAL POINTER—With tuning-condenser plates fully meshed, set pointer to coincide with first index hole above pointer.

OUTPUT METER—Connect across speaker voice coil terminals.

SIGNAL GENERATOR—Connect signal generator as indicated in chart. Use modulated output.

RADIO CONTROLS—Set volume control to maximum. Set tuning control and signal-generator frequency as indicated in chart.

OUTPUT LEVEL—During alignment, signal-generator output must be attenuated to maintain output-meter reading below .5 volt.

NOTE: While the radio is being aligned, the batteries (if used) should be in the same position with respect to the chassis and loop as they are in the cabinet.

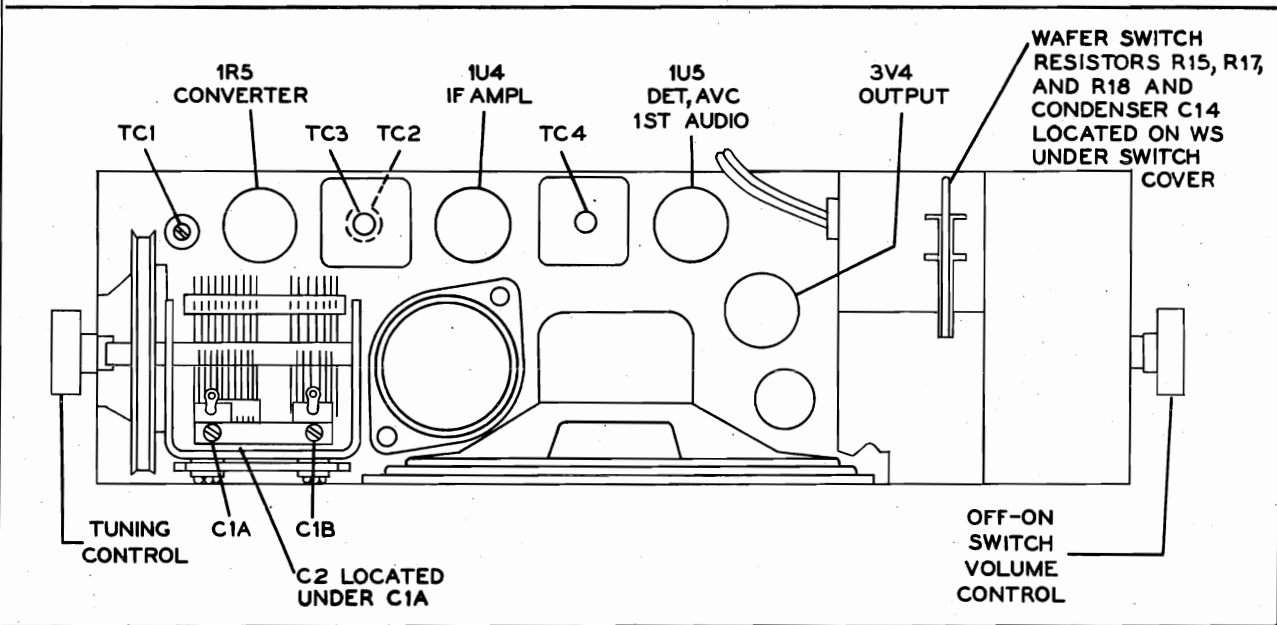

Figure 2. Top View, Showing Trimmer Locations

TP0-392

ALIGNMENT CHART

STEP	SIGNAL GENERATOR		RADIO		ADJUST
	CONNECTION TO RADIO	DIAL SETTING	DIAL SETTING	SPECIAL INSTRUCTIONS	
1	Through .1- μ f. condenser to antenna section of tuning condenser.	455 kc.	Tuning gang fully meshed	Adjust, in order given, for maximum output.	TC4—2nd i-f sec. TC3—1st i-f sec. TC2—1st i-f pri.
2	Radiating loop. See note below.	1620 kc.	1620 kc.	Adjust for maximum output.	C1B—osc. trimmer
3	Same as step 2.	1500 kc.	1500 kc.	Adjust for maximum output.	C1A—aerial trimmer
4	Same as step 2.	535 kc.	Tuning gang fully meshed	Adjust for maximum output; then repeat steps 2 and 3 until no further increase in output is obtained. This step SHOULD NOT be necessary unless the oscillator transformer has been replaced.	TC1—osc. core

RADIATING LOOP: Make up a six-to-eight turn, 6-inch-diameter loop, using insulated wire; connect to signal-generator leads, and place near radio loop aerial.

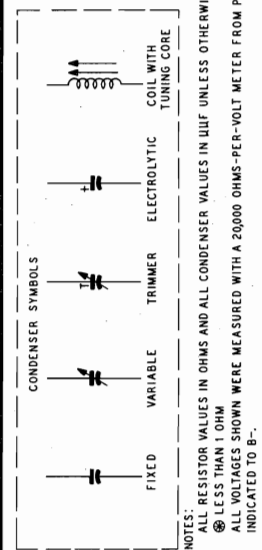
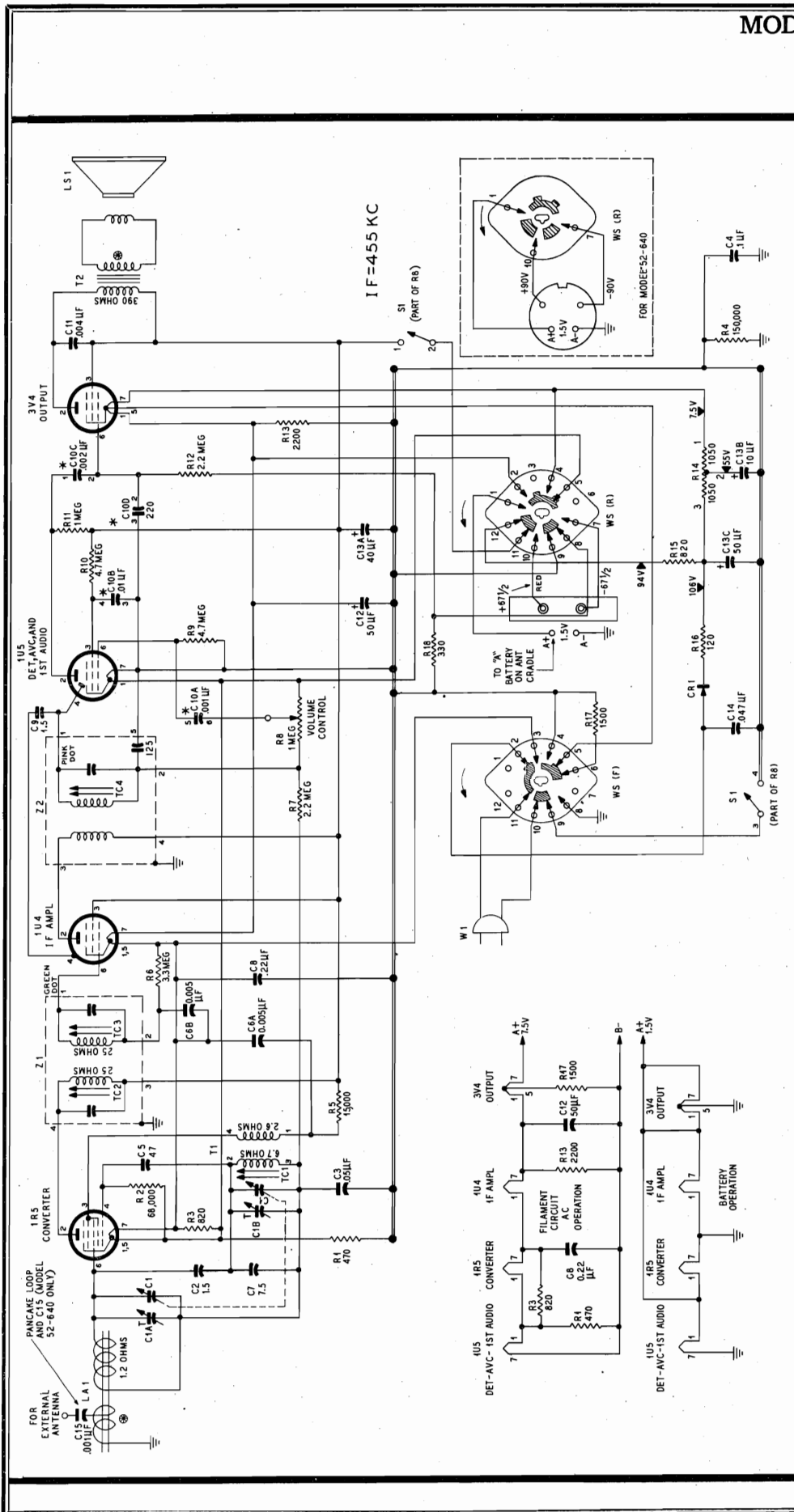

TUBE SOCKET VOLTAGES

	1R5	1U4	1U5	3V4
B SUPPLY	90V	80	80	80
OSC. PLATE	80	80	80	80
SCREEN PLATE	80	80	80	80
IF AMPL. PLATE	80	80	80	80
IF AMPL. SCREEN	80	80	80	80
IF AMPL. PIN 2	80	80	80	80
IF AMPL. PIN 3	80	80	80	80
IF AMPL. PIN 4	80	80	80	80
IF AMPL. PIN 5	80	80	80	80
IF AMPL. PIN 6	80	80	80	80
IF AMPL. PIN 7	80	80	80	80
IF AMPL. PIN 8	80	80	80	80
IF AMPL. PIN 9	80	80	80	80
IF AMPL. PIN 10	80	80	80	80
IF AMPL. PIN 11	80	80	80	80
IF AMPL. PIN 12	80	80	80	80
IF AMPL. PIN 13	80	80	80	80
IF AMPL. PIN 14	80	80	80	80
IF AMPL. PIN 15	80	80	80	80
IF AMPL. PIN 16	80	80	80	80
IF AMPL. PIN 17	80	80	80	80
IF AMPL. PIN 18	80	80	80	80
IF AMPL. PIN 19	80	80	80	80
IF AMPL. PIN 20	80	80	80	80
IF AMPL. PIN 21	80	80	80	80
IF AMPL. PIN 22	80	80	80	80
IF AMPL. PIN 23	80	80	80	80
IF AMPL. PIN 24	80	80	80	80
IF AMPL. PIN 25	80	80	80	80
IF AMPL. PIN 26	80	80	80	80
IF AMPL. PIN 27	80	80	80	80
IF AMPL. PIN 28	80	80	80	80
IF AMPL. PIN 29	80	80	80	80
IF AMPL. PIN 30	80	80	80	80
IF AMPL. PIN 31	80	80	80	80
IF AMPL. PIN 32	80	80	80	80
IF AMPL. PIN 33	80	80	80	80
IF AMPL. PIN 34	80	80	80	80
IF AMPL. PIN 35	80	80	80	80
IF AMPL. PIN 36	80	80	80	80
IF AMPL. PIN 37	80	80	80	80
IF AMPL. PIN 38	80	80	80	80
IF AMPL. PIN 39	80	80	80	80
IF AMPL. PIN 40	80	80	80	80
IF AMPL. PIN 41	80	80	80	80
IF AMPL. PIN 42	80	80	80	80
IF AMPL. PIN 43	80	80	80	80
IF AMPL. PIN 44	80	80	80	80
IF AMPL. PIN 45	80	80	80	80
IF AMPL. PIN 46	80	80	80	80
IF AMPL. PIN 47	80	80	80	80
IF AMPL. PIN 48	80	80	80	80
IF AMPL. PIN 49	80	80	80	80
IF AMPL. PIN 50	80	80	80	80
IF AMPL. PIN 51	80	80	80	80
IF AMPL. PIN 52	80	80	80	80
IF AMPL. PIN 53	80	80	80	80
IF AMPL. PIN 54	80	80	80	80
IF AMPL. PIN 55	80	80	80	80
IF AMPL. PIN 56	80	80	80	80
IF AMPL. PIN 57	80	80	80	80
IF AMPL. PIN 58	80	80	80	80
IF AMPL. PIN 59	80	80	80	80
IF AMPL. PIN 60	80	80	80	80
IF AMPL. PIN 61	80	80	80	80
IF AMPL. PIN 62	80	80	80	80
IF AMPL. PIN 63	80	80	80	80
IF AMPL. PIN 64	80	80	80	80
IF AMPL. PIN 65	80	80	80	80
IF AMPL. PIN 66	80	80	80	80
IF AMPL. PIN 67	80	80	80	80
IF AMPL. PIN 68	80	80	80	80
IF AMPL. PIN 69	80	80	80	80
IF AMPL. PIN 70	80	80	80	80
IF AMPL. PIN 71	80	80	80	80
IF AMPL. PIN 72	80	80	80	80
IF AMPL. PIN 73	80	80	80	80
IF AMPL. PIN 74	80	80	80	80
IF AMPL. PIN 75	80	80	80	80
IF AMPL. PIN 76	80	80	80	80
IF AMPL. PIN 77	80	80	80	80
IF AMPL. PIN 78	80	80	80	80
IF AMPL. PIN 79	80	80	80	80
IF AMPL. PIN 80	80	80	80	80
IF AMPL. PIN 81	80	80	80	80
IF AMPL. PIN 82	80	80	80	80
IF AMPL. PIN 83	80	80	80	80
IF AMPL. PIN 84	80	80	80	80
IF AMPL. PIN 85	80	80	80	80
IF AMPL. PIN 86	80	80	80	80
IF AMPL. PIN 87	80	80	80	80
IF AMPL. PIN 88	80	80	80	80
IF AMPL. PIN 89	80	80	80	80
IF AMPL. PIN 90	80	80	80	80
IF AMPL. PIN 91	80	80	80	80
IF AMPL. PIN 92	80	80	80	80
IF AMPL. PIN 93	80	80	80	80
IF AMPL. PIN 94	80	80	80	80
IF AMPL. PIN 95	80	80	80	80
IF AMPL. PIN 96	80	80	80	80
IF AMPL. PIN 97	80	80	80	80
IF AMPL. PIN 98	80	80	80	80
IF AMPL. PIN 99	80	80	80	80
IF AMPL. PIN 100	80	80	80	80

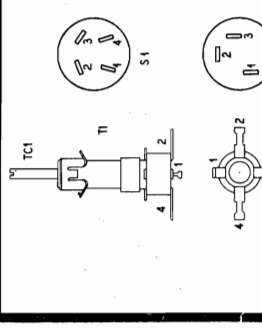
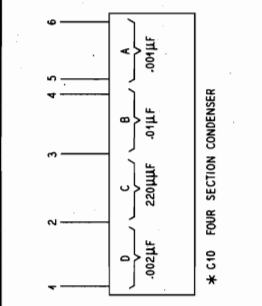

Figure 3. Philco Radio Models 52-640 and 52-641, Schematic Diagram TP1-1164

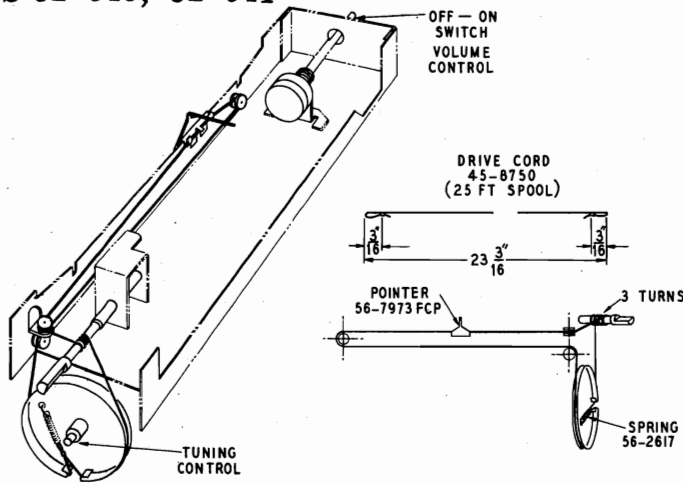

Figure 4. Drive-Cord-Installation Details

PARTS LIST

NOTE: Part numbers identified by an asterisk (*) are general replacement items. These numbers may not be identical with those on factory parts; also, the electrical values of some replacement items may differ from the values indicated in the schematic diagram and parts list. The values substituted in any case are so chosen that the operation of the radio will be either unchanged or improved. When ordering replacements, use only the "Service Part No."

Reference Symbol	Description	Service Part No.
C1	Condenser, tuning gang, 2-section Model 52-640 Model 52-641	31-2735-3 31-2735-2
C1A	Condenser, trimmer, antenna	Part of C1
C1B	Condenser, trimmer, oscillator	Part of C1
C2	Condenser, neutralizing, 1.5 µf.	30-1221-3
C3	Condenser, a-v-c by-pass, .05 µf.	61-0122*
C4	Condenser, i-f by-pass, .1 µf.	61-0113*
C5	Condenser, d-c blocking, 47 µµf.	62-051009001*
C6	Condenser, dual ceramic	30-1239
C6A	Condenser, osc. B+ by-pass, .004 µf.	Part of C6
C6B	Condenser, grid by-pass, .004 µf.	Part of C6
C7	Condenser, temperature compensation, 7.5 µµf.	30-1224-83
C8	Condenser, filament by-pass, .25 µf.	30-4656-1
C9	Condenser, neutralizing, 1.5 µµf.	30-1221-3
C10	Condenser, ceramic, 4-section	30-1327
C10A	Condenser, d-c blocking, .001 µf.	Part of C10
C10B	Condenser, screen by-pass, .01 µf.	Part of C10
C10C	Condenser, d-c blocking, .002 µf.	Part of C10
C10D	Condenser, grid by-pass, 220 µµf.	Part of C10
C11	Condenser, tone compensation, .004 µf.	61-0179*
C12	Condenser, electrolytic, filament by-pass, 50 µf., 25v	30-2417-12
C13	Condenser, electrolytic, 3-section	30-2568-39
C13A	Condenser, filter, 40 µf., 150v	Part of C13
C13B	Condenser, filter, 10 µf., 150v	Part of C13
C13C	Condenser, filter, 50 µf., 150v	Part of C13
C14	Condenser, line by-pass, .047 µf.	45-3505-45*
C15	Condenser, antenna coupling, .001 µf.	45-3500-5
CR1	Selenium rectifier, 75 ma. at 117 volts	34-8003-1*
LA1	Loop aerial Model 52-640 (flat loop)	32-4052-52
	Model 52-641 (Magnechor)	32-4455
LS1	Speaker, 4-inch p.m.	36-1627-21
R1	Resistor, current limiting, 470 ohms	66-1478340*
R2	Resistor, grid return, 68,000 ohms	66-3688340*
R3	Resistor, bias, 880 ohms	66-1888340*
R4	Resistor, leakage, 150,000 ohms	66-4158340*
R5	Resistor, oscillator dropping, 15,000 ohms	66-3158340*
R6	Resistor, grid return, 3.3 megohms	66-5338340*
R7	Resistor, a-v-c filter, 2.2 megohms	66-5228340*
R8	Resistor, VOLUME control (with "off-on" switch), 1 megohm	33-5566-21
R9	Resistor, grid return, 4.7 megohms	66-5478340*

Reference Symbol	Description	Service Part No.
R10	Resistor, screen dropping, 4.7 megohms	66-5478340*
R11	Resistor, plate load, 1 megohm	66-5108340*
R12	Resistor, grid return, 2.2 megohms	66-5228340*
R13	Resistor, bias, 2200 ohms	66-2228340*
R14	Resistor, filament dropping and filter, 2100 ohms (center-tapped)	33-3445
R15	Resistor, filter, 820 ohms	66-1828340*
R16	Resistor, current limiting, 120 ohms	33-1334-14
R17	Resistor, bias, 1500 ohms	66-2158340*
R18	Resistor, bias, 330 ohms	66-1338340*
S1	Switch, off-on	Part of R8
T1	Transformer, oscillator	32-4453-1
T2	Transformer, output	32-8434
W1	Line cord	L2183
WS	Wafer switch, voltage change-over	42-1925
Z1	Transformer, 1st i-f	32-4160-4A
Z2	Transformer, 2nd i-f	32-4454-1A

MISCELLANEOUS

Description	Service Part No.
Cabinet, Model 52-640, maroon	10816-3
Back, maroon	54-4810
Clip (2), back	56-3807-3
Handle-and-bracket assembly	76-6967
Handle	54-4811-2
Knob assembly (2)	76-6206
Pointer	56-7973-1
Cabinet, Model 52-641, maroon	10799-1
Back, maroon	54-4767-1
Cabinet, Model 52-641, red	10799-2
Back, red	54-4767-2
Cabinet, Model 52-641, Nile	10799-4
Back, Nile	54-4767-4
Cabinet, Model 52-641, sand	10799-5
Back, sand	54-4767-5
Clip (2), back	56-9162
Fastener (2)	W2235-7FA9
Handle-and-bracket assembly	76-6061
Handle	56-7940FCP
Hinge, l.h.	56-7915
Hinge, r.h.	56-7915-1
Knob (2)	54-4773
Pointer	56-7973FCP
Scale, dial	54-5087
Baffle-and-cloth assembly	40-7884
Insulator, electrolytic-condenser mounting	27-9508
Cable-and-connector assembly, battery	41-3988
Drive cord (25-ft. spool)	45-8750*
Mount, rubber, tuning gang	27-4099-3
Retaining ring	1W60978FA3
Spring, drive cord	56-2617
Socket (2), tube, 1R5 and 1U4	27-6203
Socket (2), tube, 1U5 and 3V4	27-6203-12
Tube shield, 1U5	56-3978-1FA3
Tuning shaft	56-7906FA42

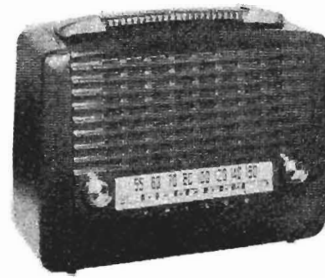

MODEL 52-643

SPECIFICATIONS

CABINET	Molded plastic, brown
CIRCUIT	Five-tube superheterodyne (plus selenium rectifier)
FREQUENCY RANGE	540—1620 kc.
AUDIO OUTPUT	160 milliwatts
OPERATING VOLTAGES	117 volts, a.c. or d.c.; or 9-volt "A" battery and 90-volt "B" battery
POWER CONSUMPTION	
A-c or d-c operation	15 watts
Battery operation	55 ma. at 9 volts, and 13 ma. at 90 volts
AERIAL	Magnecor high-impedance loop; provision for connecting external aerial
INTERMEDIATE FREQUENCY	265 kc.
PHILCO TUBES (5)	1T4 r-f ampl., 1R5 converter, 1U4 i-f ampl., 1U5 det.-a.v.c.—1st audio, 3V4 output
BATTERY TYPE	Philco P-363

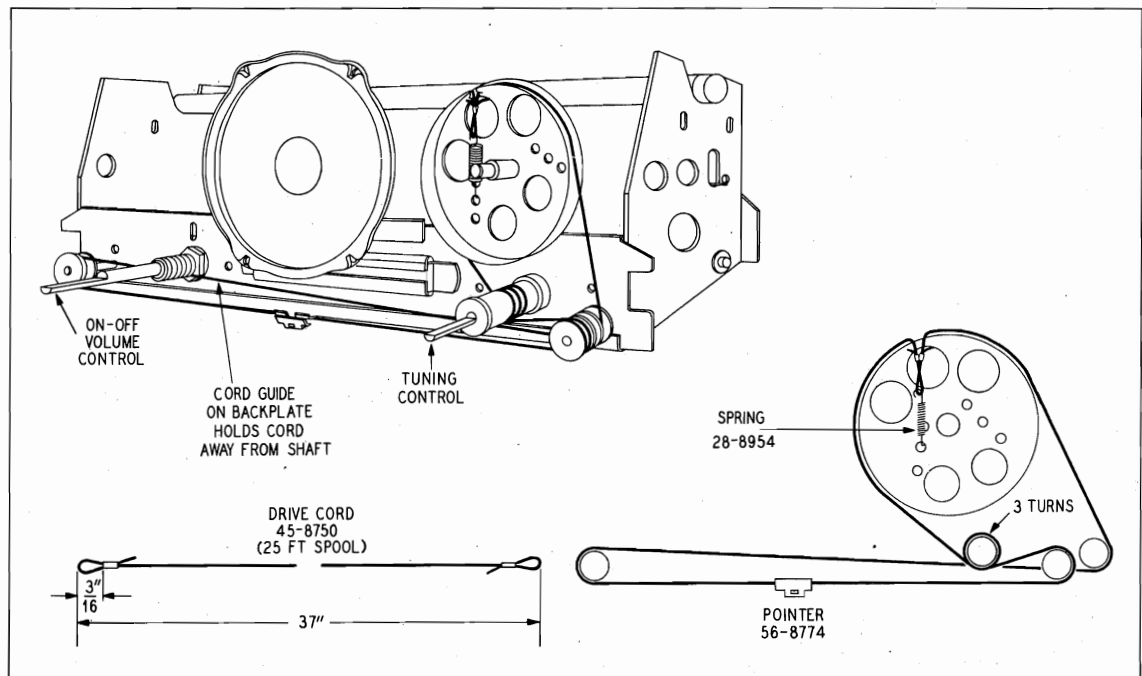

TPI-1711

Figure 1. Drive-Cord-Installation Details

ALIGNMENT PROCEDURE

POINTER—Set pointer to coincide with first index mark from left side of dial backplate (looking at backplate).

RADIO CONTROLS—Set volume control to maximum.

OUTPUT METER—Connect across voice-coil terminals.

SIGNAL GENERATOR—Use modulated output.

OUTPUT LEVEL—During alignment, adjust signal-generator output to maintain output-meter indication below .5 volt.

SPECIAL NOTE—The orientation of the loop with respect to the chassis and battery is critical for correct tracking. During

alignment, with the cabinet back (containing the loop) lying flat on the bench, the chassis should be laid on its back in approximately its normal relation to the loop, with a 1/4" thick wooden board separating the loop and chassis. The battery should also be placed as close as possible to its normal position with respect to the chassis and loop.

CRITICAL LEAD DRESS—To secure proper padding capacity, the green lead from pin 6 of the 1R5 tube to Z1 must be dressed over wiring panel, away from chassis, and the green lead from Z1 to the tuning condenser must be dressed away from chassis.

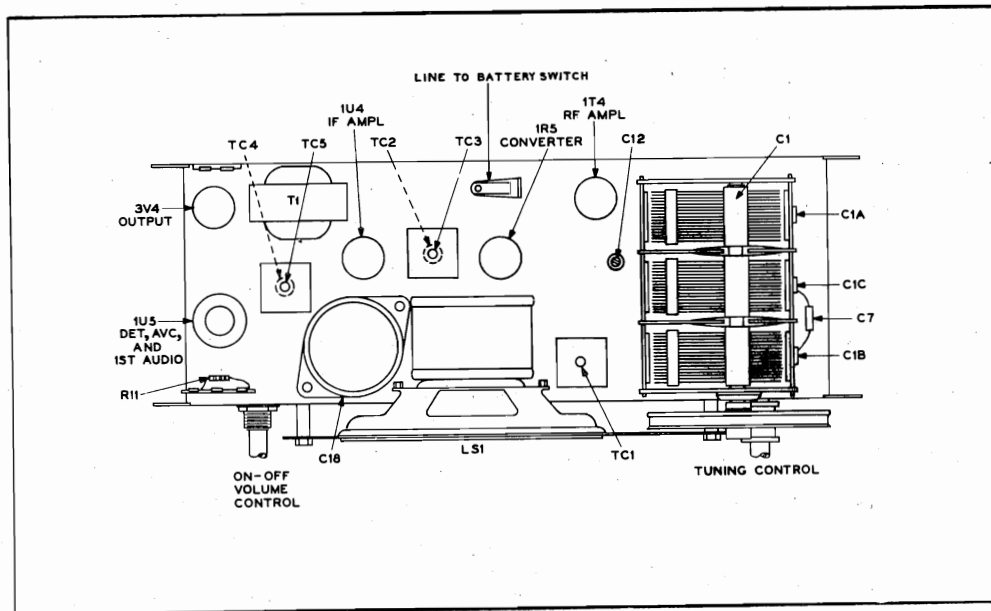

Figure 2. Top View, Showing Trimmer Locations

TP1-1712

ALIGNMENT CHART

STEP	SIGNAL GENERATOR		RADIO		ADJUST
	CONNECTION TO RADIO	DIAL SETTING	DIAL SETTING	SPECIAL INSTRUCTIONS	
1	Through a .1- μ f. condenser to pin 6 of the 1R5 converter.	265 kc.	1620 kc. (gang fully open)	Adjust, in order given, for maximum output.	TC5—2nd i-f sec. TC4—2nd i-f pri. TC2—1st i-f pri. TC3—1st i-f sec.
2	Radiating loop. See note below.	1620 kc.	1620 kc. (gang fully open)	Adjust for maximum output. If low-frequency dial tracking is far off, make adjustments in steps 3 and 4 before making this adjustment.	C1C—osc. shunt
3	Same as step 2.	580 kc.	580 kc.	Adjust for maximum output while rocking tuning control.	C13—osc. series
4	Same as step 2.	580 kc.	580 kc.	Adjust for maximum output. This adjustment should not be made unless dial tracking is off, or sensitivity is low at low-frequency end (580 kc.).	TC1—r-r sec.
5	Same as step 2.	1500 kc.	1500 kc. (index mark at right)	Adjust, in order given, for maximum output.	C1B—r-f trimmer C1A—aerial trimmer
6	Repeat steps 3 and 5 until no further improvement is obtained.				

RADIATING LOOP: Make up a six-to-eight-turn, 6-inch-diameter loop using insulated wire; connect to signal-generator leads and place near radio loop.

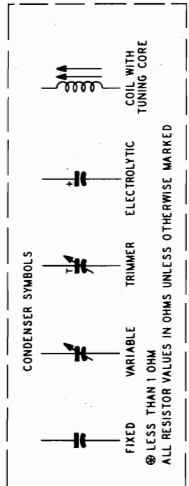
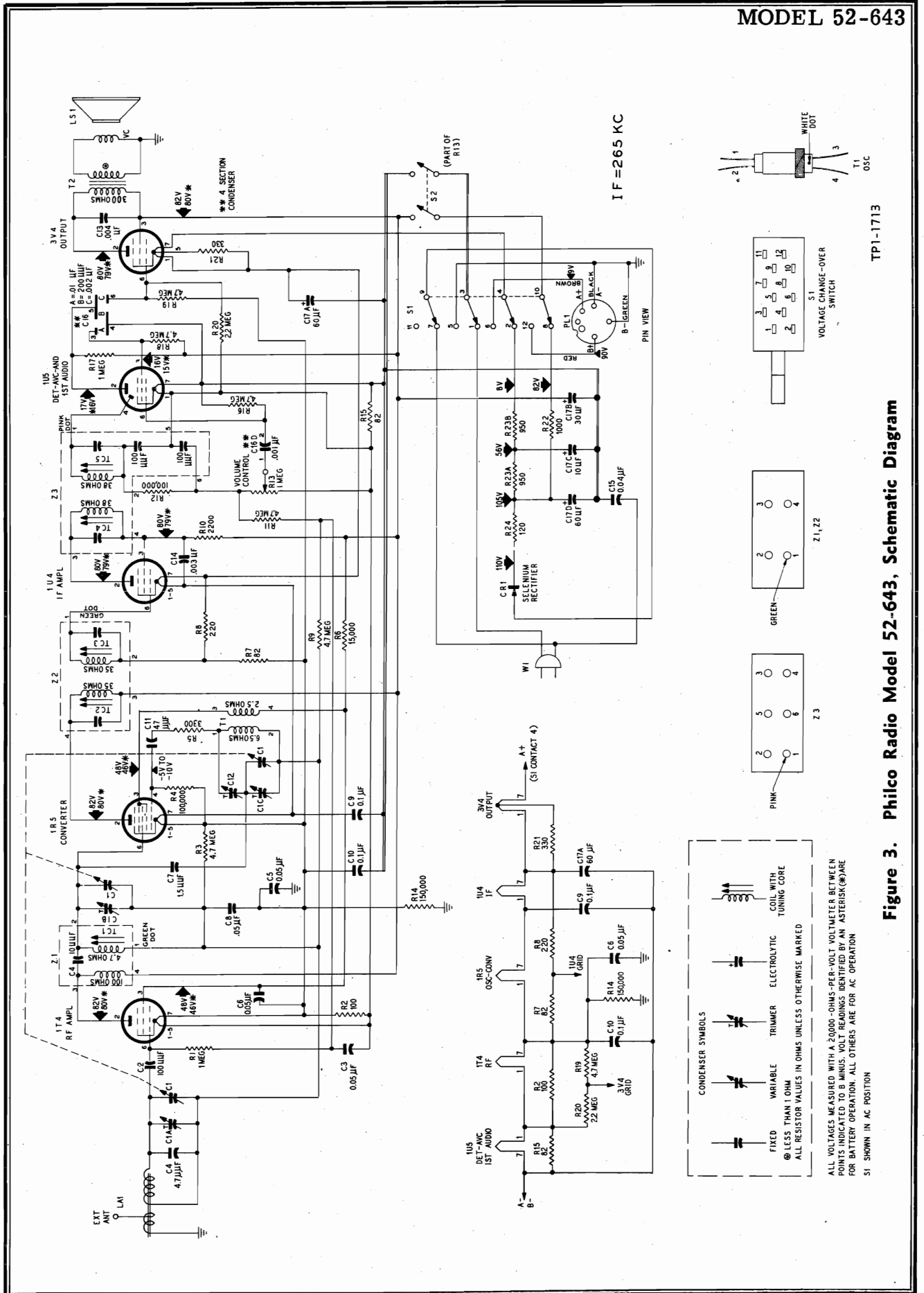

TP1-1713

Figure 3. Philco Radio Model 52-643, Schematic Diagram

PARTS LIST

NOTE: Part numbers identified by an asterisk (*) are general replacement items. These numbers may not be identical with those on factory parts; also, the electrical values of some replacement items may differ from the values indicated in the schematic diagram and parts list. The values substituted in any case are so chosen that the operation of the radio will be either unchanged or improved. When ordering replacements, use only the "Service Part No."

Reference Symbol	Description	Service Part No.
C1	Condenser, tuning gang, 3-section	31-2747-2
C1A	Condenser, antenna trimmer	Part of C1
C1B	Condenser, r-f trimmer	Part of C1
C1C	Condenser, osc. trimmer	Part of C1
C2	Condenser, d-c blocking, 100 μ f.	62-110009001*
C3	Condenser, bias filter, .05 μ f.	61-0122*
C4	Condenser, fixed trimmer, 4.7 μ f.	30-1230
C5	Condenser, filament by-pass, .05 μ f.	61-0122*
C6	Condenser, screen by-pass, .05 μ f.	61-0122*
C7	Condenser, neutralization, 1.5 μ f.	30-1221-3
C8	Condenser, α -v-c filter, .05 μ f.	61-0122*
C9	Condenser, filament by-pass, .1 μ f.	61-0113*
C10	Condenser, filament by-pass, .1 μ f.	61-0113*
C11	Condenser, d-c blocking, 47 μ f.	60-00475417*
C12	Condenser, osc. series padder, 600 to 800 μ f.	31-6473-16
C13	Condenser, tone compensation, .004 μ f.	61-0179*
C14	Condenser, screen neutralizing, .003 μ f.	61-0109*
C15	Condenser, line by-pass, .04 μ f.	45-3500-2*
C16	Condenser, ceramic, 4-section	30-1237
C16A	Condenser, screen by-pass, .01 μ f.	Part of C16
C16B	Condenser, by-pass, 200 μ f.	Part of C16
C16C	Condenser, d-c blocking, .002 μ f.	Part of C16
C16D	Condenser, d-c blocking, .001 μ f.	Part of C16
C17	Condenser, electrolytic, 4-section	30-2568-26
C17A	Condenser, filament by-pass, 60 μ f.	Part of C17
C17B	Condenser, filter, 30 μ f.	Part of C17
C17C	Condenser, filter, 10 μ f.	Part of C17
C17D	Condenser, filter, 60 μ f.	Part of C17
CR1	Selenium rectifier	34-8003*
LA1	Coil, antenna	32-4455-4
LS1	Speaker, 5-inch	36-1625
PL1	Plug and cable, battery	41-3712-5
R1	Resistor, grid return, 1 megohm	66-5108340*
R2	Resistor, current limiting, 100 ohms	66-1108340*
R3	Resistor, grid return, 4.7 megohms	66-5478340*
R4	Resistor, grid return, 100,000 ohms	66-4108340*
R5	Resistor, oscillator coupling, 3300 ohms	66-2338340*
R6	Resistor, dropping, 15,000 ohms	66-3158340*
R7	Resistor, grid return, 82 ohms	66-0828340*

Reference Symbol	Description	Service Part No.
R8	Resistor, grid return, 220 ohms	66-1228340*
R9	Resistor, α -v-c filter, 4.7 megohms	66-5478340*
R10	Resistor, neutralization, 2200 ohms	66-2228340*
R11	Resistor, α -v-c filter, 4.7 megohms	66-5478340*
R12	Resistor, i-f filter, 100,000 ohms	66-4108340*
R13	Resistor, VOLUME control, 1 megohm	33-5566-11
R14	Resistor, leakage, 150,000 ohms	66-4158340*
R15	Resistor, current limiting, 82 ohms	66-0828340*
R16	Resistor, grid return, 4.7 megohms	66-5478340*
R17	Resistor, plate load, 1 megohm	66-5108340
R18	Resistor, screen dropping, 4.7 megohms	66-5478340*
R19	Resistor, grid return, 4.7 megohms	66-5478340*
R20	Resistor, grid return, 2.2 megohms	66-5228340*
R21	Resistor, current limiting, 330 ohms	66-1338340*
R22	Resistor, filter, 1000 ohms	66-2108340*
R23	Resistor, wire wound, 2-section	33-3431-7
R23A	Resistor, filament dropping, 950 ohms	Part of R23
R23B	Resistor, filament dropping, 950 ohms	Part of R23
R24	Resistor, wire wound, current limiting, 120 ohms	33-1334-14
S1	Switch, change-over	42-1899
S2	Switch, on-off	Part of R13
T1	Transformer, oscillator	32-4263-2
T2	Transformer, output	32-8528
W1	Line cord	L2183
Z1	Transformer, r-f	32-4399A
Z2	Transformer, 1st i-f	32-4160-2A
Z3	Transformer, 2nd i-f	32-4240-6A

MISCELLANEOUS

Description	Service Part No.
Cabinet complete	10883
Back	54-4903
Clip (2), back	56-3807-3
Handle assembly	76-6970
Scale	54-5127
Dial backplate assembly	76-7042
Backplate	56-9190FCP
Drive cord, 25-ft. spool	45-8750*
Pointer	56-8774
Spring, drive cord	28-8954
Shaft-and-pulley assembly	76-3671-4
Bushing	27-9437
Clip (1)	56-7057FA3
Knob (2)	54-4773-1
Mount (3), rubber	27-4596
Spring, retaining	57-1468FA3
Shield, 1U5 tube	56-5629FA3
Socket (4)	27-6203
Socket (1), 1U5 tube	27-6203-22

Handle end cover, plastic	54-4909
Handle mounting bracket, metal	56-9583

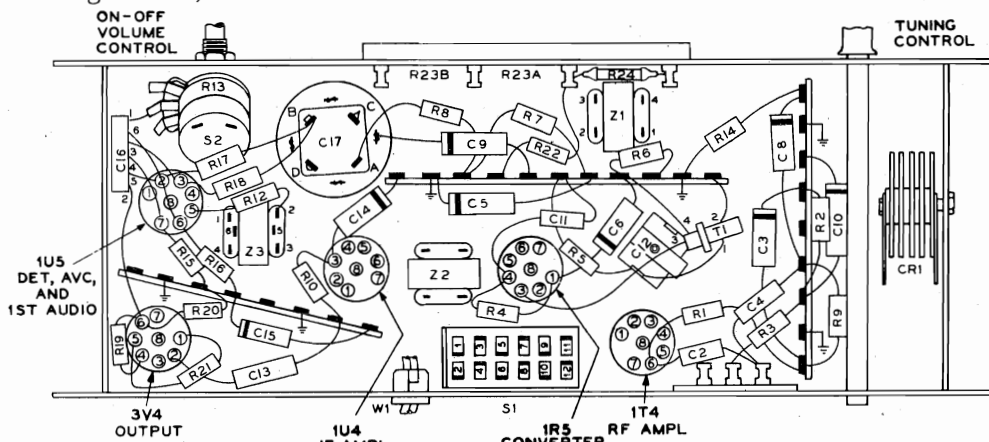
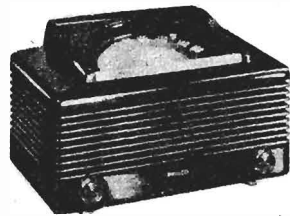
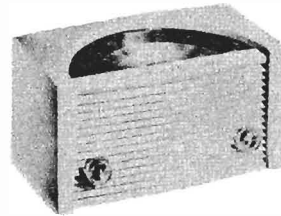

Figure 4. Bottom View, Showing Symbolized Chassis

TP1-1710



MODEL 52-940



MODEL 52-941

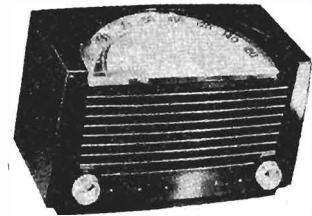

MODEL 52-942

SPECIFICATIONS

CABINET	
Model 52-940	Molded plastic, mahogany or gray, wide-angle dial
Model 52-941	Molded plastic, ivory, wide-angle dial
Model 52-942	Molded plastic, maroon, wide-angle dial
CIRCUIT	Five-tube superheterodyne (plus rectifier)
FREQUENCY RANGE	540—1620 kc.
AUDIO OUTPUT	1 watt
OPERATING VOLTAGE	105—120 volts, a.c. or d.c.
POWER CONSUMPTION	30 watts
AERIAL	High-impedance loop; provision for connecting external aerial
INTERMEDIATE FREQUENCY	455 kc.
PHILCO TUBES (6)	7B7 r-f ampl., 7A8 converter, 7B7 i-f ampl., 14B6 det.-a.v.c.-1st audio, 35L6GT output, 35Z5GT rectifier

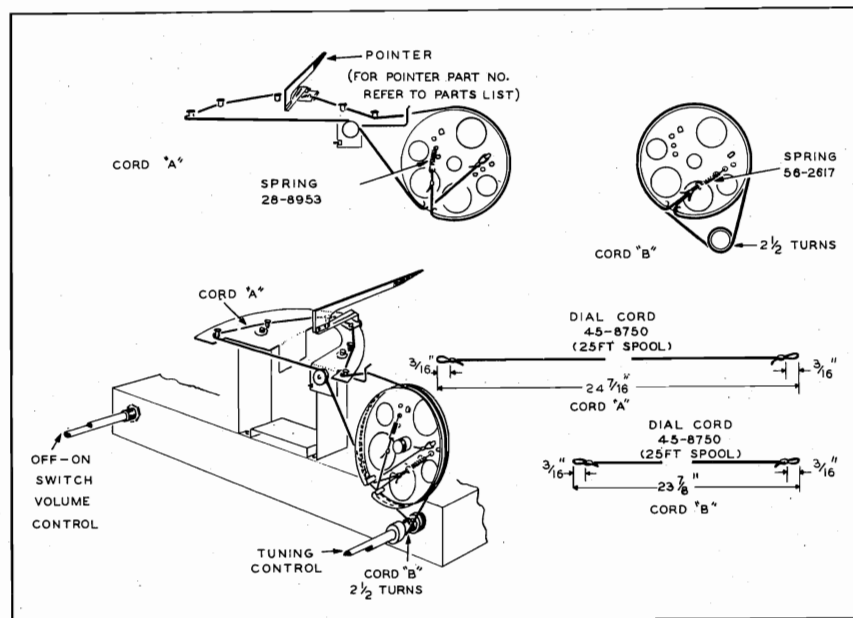

TP9-636A

Figure 1. Dial-Cord Installation Details

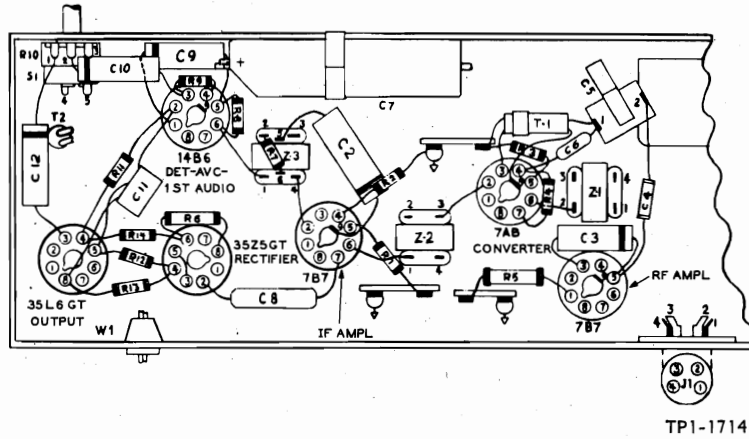

Figure 2. Bottom View, Showing Symbolized Chassis

ALIGNMENT PROCEDURE

DIAL POINTER: Turn tuning condenser to full-mesh position. Adjust pointer so that center of pointer carriage coincides with the first scribe line from the left.

OUTPUT METER: Connect across speaker voice coil.

SIGNAL GENERATOR: Connect as indicated in chart. Use modulated output.

OUTPUT LEVEL: During alignment, attenuate signal-generator output to maintain an output-meter indication of 1.25 volts.

VOLUME CONTROL: Set to maximum.

CRITICAL DRESS: The green lead from the osc. section of C1 to C5 must be dressed away from the chassis, with all excess under the chassis.

ALIGNMENT CHART

STEP	SIGNAL GENERATOR		RADIO		ADJUST
	CONNECTION TO RADIO	DIAL SETTING	DIAL SETTING	SPECIAL INSTRUCTIONS	
1	Through a .1- μ f. condenser to stator of r-f section of gang. Ground lead to B-.	455 kc.	Gang fully meshed	Adjust, in order given, for maximum output.	TC5—2nd i-f sec. TC4—2nd i-f pri. TC3—1st i-f sec. TC2—1st i-f pri.
2	Radiating loop. (See note below.)			Preset 1/2 turn from right.	C5—osc. series
3	Same as step 2.	1620 kc.	1620 kc.	Adjust for maximum.	C1B—osc. shunt
4	Same as step 2.	1500 kc.	1500 kc.	Adjust for maximum.	C1C—r-f C1A—aerial
5	Same as step 2.	580 kc.	580 kc.	Adjust for maximum while rocking tuning control.	C5—osc. series TC1—r-f core
6	Repeat steps 3 and 4.				

RADIATING LOOP: Make up a 6—8 turn, 6-inch-diameter loop from insulated wire; connect to signal-generator leads and place near radio loop aerial. The loop aerial must be connected to the radio.

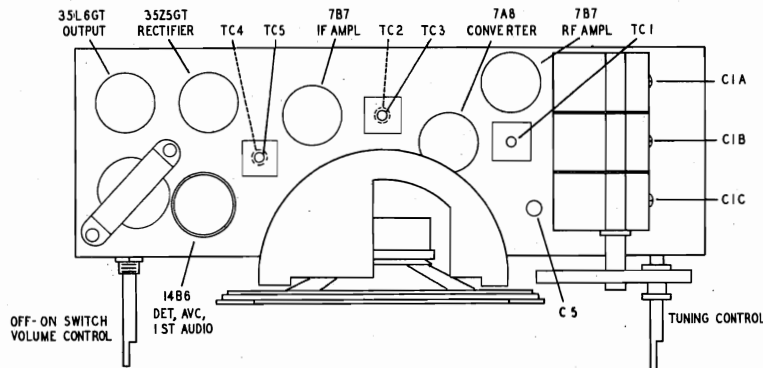
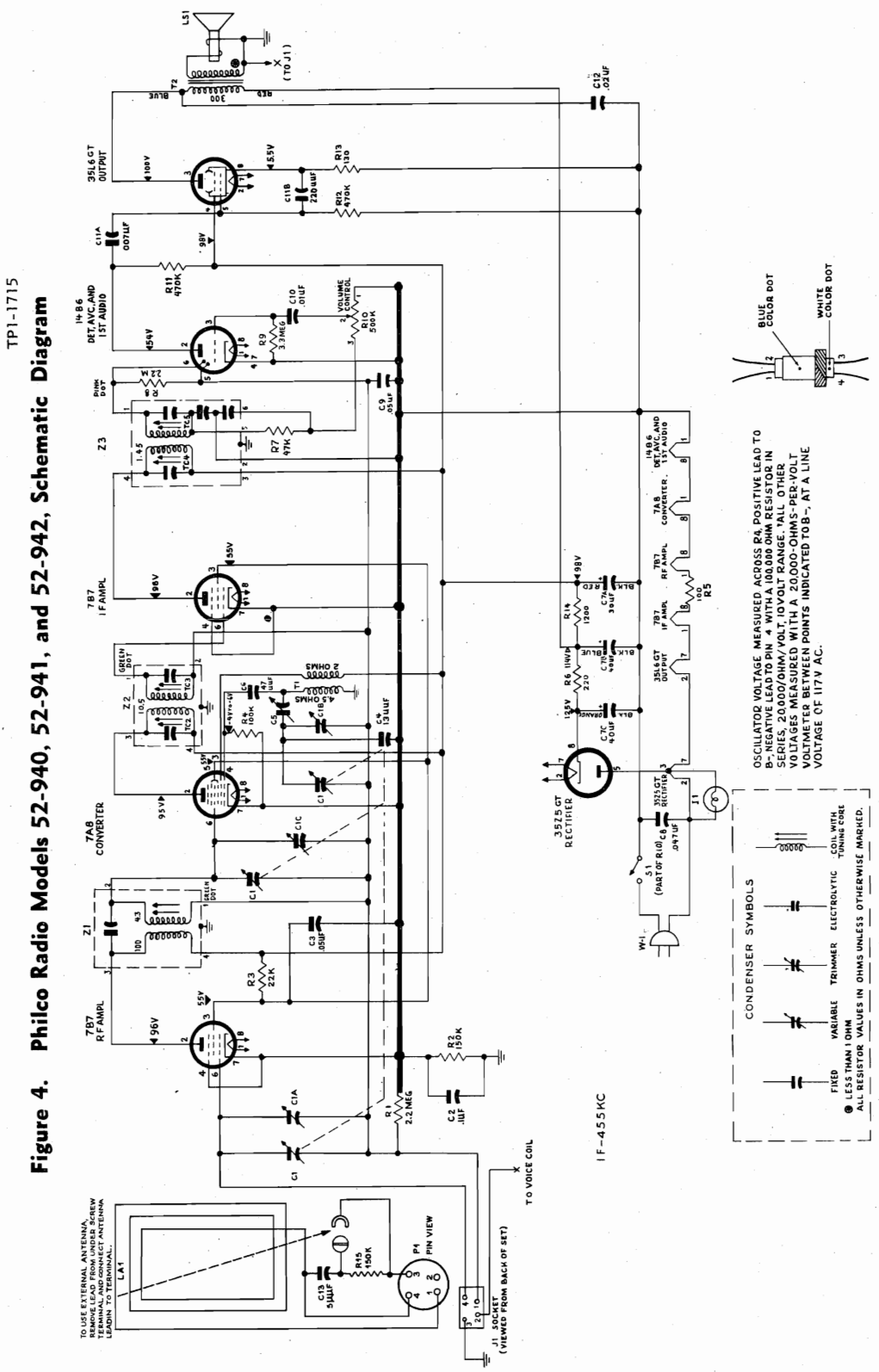

Figure 3. Top View, Showing Trimmer Locations

TP9-636B

Figure 4. Philco Radio Models 52-940, 52-941, and 52-942, Schematic Diagram



SUPPLEMENT TO MODEL 52-940

Additions to parts list (for ivory model):

- Bezel, metal 56-7427-1
- Knob (2) 54-4718-7
- Scale, dial 54-5070-3

PARTS LIST

NOTE: Part numbers marked with an asterisk (*) are general replacement items. These numbers may not be identical with those on factory parts; also, the electrical values of some replacement items may differ from the values indicated in the schematic diagram and parts list. The values substituted in any case are so chosen that the operation of the radio will be either unchanged or improved. When ordering replacements, use only the "Service Part No."

Reference Symbol	Description	Service Part No.	MISCELLANEOUS Description	Service Part No.
C1	Condenser, tuning, 3-section	31-2748-1	Cabinet, Model 52-940, mahogany	10770-4
C1A	Condenser, trimmer, aerial	Part of C1	Cabinet, Model 52-940, gray	10770-3
C1B	Condenser, trimmer, osc.	Part of C1	Back	54-7917
C1C	Condenser, trimmer, r-f	Part of C1	Fastener (4), back	W-2235FA9
C2	Condenser, by-pass, .1 μ f.	61-0113*	Backplate, ornamental, mahogany cabinet	56-7426FCP
C3	Condenser, by-pass, .05 μ f.	61-0122*	Backplate, ornamental, gray cabinet	56-7426-1FCP
C4	Condenser, fixed trimmer, temperature comp., 13 μ f.	30-1224-68	Fastener, backplate mtg.	W-2235-1FA9
C5	Condenser, padder, osc. series	31-6473-17	Baffle	54-7938-3
C6	Condenser, d-c blocking, 47 μ f.	60-00475417	Fastener (4), baffle mtg.	W-2235-2FA9
C7	Condenser, electrolytic, 3-section	30-2575-27	Bezel, metal	56-7427
C7A	Condenser, filter, 30 μ f., 150v	Part of C7	Speed nut (2), bezel mtg.	1W60196FE7
C7B	Condenser, filter, 40 μ f., 150v	Part of C7	Dial scale, mahogany cabinet	54-5070-3
C7C	Condenser, filter, 40 μ f., 150v	Part of C7	Dial scale, gray cabinet	54-5070-4
C8	Condenser, line by-pass .047 μ f.	45-3505-45	Clip, scale mtg.	36-7886FE7
C9	Condenser, α -v-c filter, .05 μ f.	61-0122*	Knob (2), mahogany cabinet	54-4718-4
C10	Condenser, d-c blocking, .01 μ f.	61-0120*	Knob (2), gray cabinet	54-4718-7
C11	Condenser, dual ceramic	30-1239-4	Pointer	76-5341-1
C11A	Condenser, d-c blocking, .007 μ f.	Part of C11	Cabinet, Model 52-941	10771
C11B	Condenser, by-pass, 220 μ f.	Part of C11	Back	54-7921
C12	Condenser, tone compensation, .02 μ f.	61-0108*	Fastener (4), back	W-2235FA9
C13	Condenser, antenna coupling, 5 μ f.	30-1230	Backplate, ornamental	56-7434-1
I1	Pilot lamp, 6-8v	34-2068	Fastener, backplate mtg.	W-2235-2FA9
J1	Jack, aerial input	27-6214-1	Baffle, cardboard	54-7922
LA1	Loop aerial, Model 52-940	32-4052-57	Fastener (4), baffle mtg.	W-2235-2FA9
LA1	Loop aerial, Model 52-941	32-4052-58	Dial scale	54-5071
LA1	Loop aerial, Model 52-942	32-4052-59	Clip, dial mtg.	56-7808FE7
LS1	Speaker, p-m, 4 in. x 6 in. oval	36-1633-1	Knob (2)	54-4718-5
P1	Loop-aerial plug	27-4788	Pointer	76-5341-4
R1	Resistor, α -v-c load, 2.2 megohms	66-5228340*	Cabinet, Model 52-942	10772
R2	Resistor, leakage, 150,000 ohms	66-4158340*	Back	54-7920
R3	Resistor, dropping, 22,000 ohms	66-3228340*	Fastener (4), back	W-2235FA9
R4	Resistor, grid return, 100,000 ohms	66-4108340*	Backplate, ornamental	56-7435
R5	Resistor, filament dropping, 100 ohms	33-1343-3	Fastener, backplate mtg.	W-2235-1FA9
R6	Resistor, filter, 220 ohms, 1 watt	66-1224340*	Baffle, cardboard	54-7919-2
R7	Resistor, i-f filter, 47,000 ohms	66-3478340*	Fastener (4), baffle mtg.	W-2235-2FA9
R8	Resistor, diode load, 2.2 megohms	66-5228340*	Bezel, metal	56-7536
R9	Resistor, grid return, 3.3 megohms	66-5338340*	Speed nut, bezel mtg.	1W60196FE7
R10	Resistor, VOLUME control (with on-off switch), 500,000 ohms	33-5566-13	Dial scale	54-5072-1
R11	Resistor, plate load, 470,000 ohms	66-4478340*	Clip (2), dial mtg.	56-7572FE11
R12	Resistor, grid return, 470,000 ohms	66-4478340*	Knob (2)	54-4718-3
R13	Resistor, cathode bias, 130 ohms	66-1138340*	Pointer	76-5341-3
R14	Resistor, filter, 1200 ohms	66-2128340*	Backplate, pulley-and-clip assembly	76-5233
R15	Resistor, leakage, 150,000 ohms	66-4158340*	Clamp, electrolytic mtg.	56-1466FA5
S1	Switch, off-on	Part of R10	Dial cord, 25-foot spool	45-8750*
T1	Transformer, oscillator	32-4263-2	Spring, gang drive	56-2617
T2	Transformer, output	32-8310-3	Spring, pointer drive	28-8953
W1	Line cord	L-2183*	Drive shaft	76-3671-6
Z1	Transformer, r-f	32-4399-2A	Bushing, drive shaft	27-9437
Z2	Transformer, 1st i-f	32-4160A	Spring (2), hairpin, drive shaft	57-1468FA3
Z3	Transformer, 2nd i-f	32-4240-3A	Panel, wiring, external aerial	38-9837
			Panel, wiring, 4-lug	38-9161-1
			Plug, aerial, 4-pin	6214-1
			Rubber mount (4), gang mtg.	27-4771-1
			Shield, tube, 14B6	56-1566
			Socket (4), Loktal	27-6269
			Socket (2), octal	27-6174
			Socket assembly, pilot lamp	27-6233-6



MODEL 52-944

SPECIFICATIONS

- CABINETPlastic table model
- CIRCUIT Six-tube superheterodyne plus selenium rectifier
- FREQUENCY RANGES
 - Broadcast540-1620 kc.
 - FM88—108 mc.
- AUDIO OUTPUT1 watt
- OPERATING VOLTAGE105—125 volts, a.c./d.c.
- POWER CONSUMPTION45 watts
- AERIALBuilt-in pancake loop for AM, line cord for FM;
provision for connecting external aerial
- INTERMEDIATE FREQUENCY
 - AM455 kc.
 - FM9.1 mc.
- PHILCO TUBES (6)12AU6 r-f ampl., 12AT7 converter, 12BA6 1st i-f ampl., 12AU6 2nd i-f ampl., 19V8 det.—a.v.c.—1st audio, 35C5 output

TP1-1703

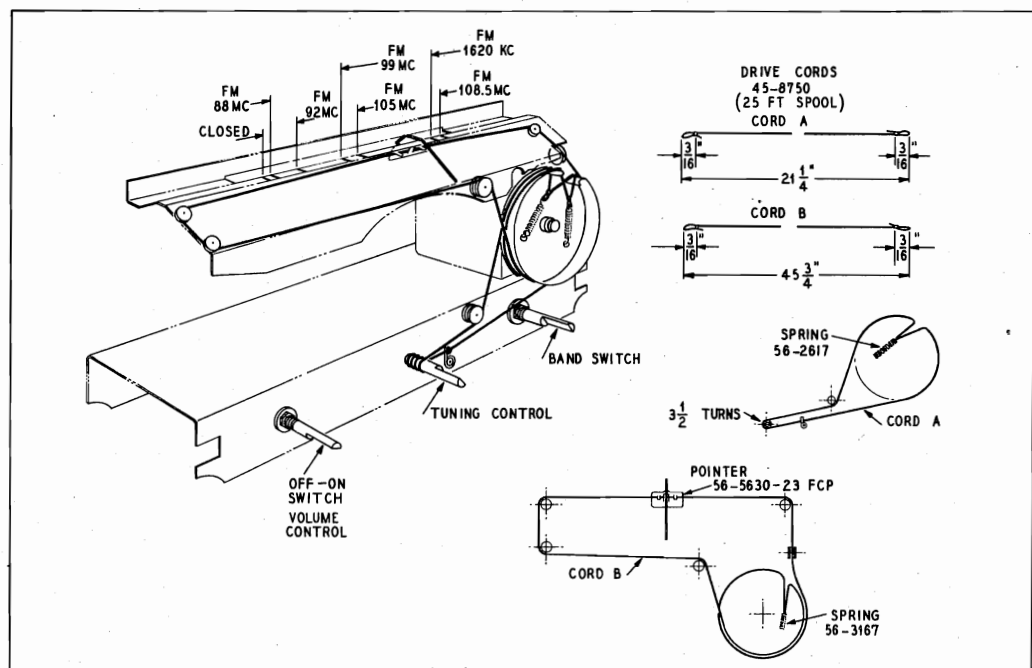

TP0-373

Figure 1. Dial-Cord Installation Details

PR-1955

AM ALIGNMENT PROCEDURE

Make alignment with loop aerial connected to radio. The AM alignment should be completed before the FM alignment is made.

DIAL POINTER—With tuning-condenser plates fully meshed, adjust pointer to coincide with index mark at low-frequency end of dial backplate.

RADIO CONTROLS—Set volume control to maximum, set band switch for broadcast reception, and set tuning control as indicated in chart.

OUTPUT METER—Connect across voice-coil terminals.

SIGNAL GENERATOR—Use AM r-f signal generator, with modulated output. Connect generator and set frequency as indicated in chart.

OUTPUT LEVEL—During alignment, signal-generator output must be attenuated to hold output-meter reading below 1.25 volts.

AM ALIGNMENT CHART

STEP	SIGNAL GENERATOR		RADIO		ADJUST
	CONNECTION TO RADIO	DIAL SETTING	DIAL SETTING	SPECIAL INSTRUCTIONS	
1	Ground lead to chassis. Output lead through a .1- μ f. condenser to junction of LA1 and L8.	455 kc.	Gang fully open	Adjust for maximum output.	TC10—2nd AM i-f sec. TC9—2nd AM i-f pri. TC4—1st AM i-f sec. TC3—1st AM i-f pri.
2	Radiating loop. See note below.	1620 kc.	1620 kc. (2nd index mark from right)	Adjust for maximum output.	C1C—osc. trimmer
3	Same as step 2.	1500 kc.	1500 kc.	Adjust for maximum output.	C1A—aerial trimmer

RADIATING LOOP: Make up a six-to-eight turn, 6-inch-diameter loop from insulated wire; connect to generator terminals, and place near radio loop aerial. Radio loop aerial must be connected.

FM ALIGNMENT PROCEDURE

Make AM alignment first

RADIO CONTROLS—Set volume control to maximum, set band switch for FM reception, and set tuning control as indicated in chart.

OSCILLOSCOPE—Connect ground lead to chassis. Connect vertical input to FM TEST jack, J2; connect horizontal input to horizontal sweep output of sweep generator. (Oscilloscope is used for steps 1 and 2.)

SWEEP GENERATOR—Use r-f sweep signal generator. Connect ground lead to chassis. Connect output lead and set frequency and sweep width as indicated in chart.

OUTPUT METER—Connect across voice-coil terminals.

NOTE: Before starting FM alignment, allow radio and signal generator to warm up for 15 minutes.

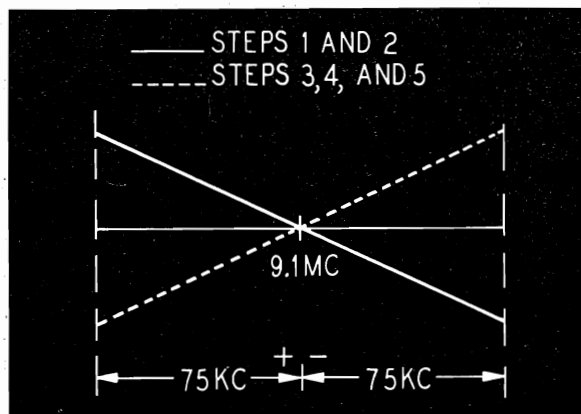

Figure 2. Characteristic Curve of FM Detector

TPI-2111

FM ALIGNMENT CHART

STEP	SIGNAL GENERATOR		RADIO		ADJUST
	CONNECTION TO RADIO	DIAL SETTING	DIAL SETTING	SPECIAL INSTRUCTIONS	
1	Connect FM signal generator through a .01- μ f. condenser to control grid (pin 1) of 12AU6 2nd i-f amplifier.	9.1 mc. (75-kc. deviation).	88 mc. (gang meshed).	Balance and adjust detector for maximum indication on scope as shown in figure 5.	TC8—detector sec. TC7—detector pri.

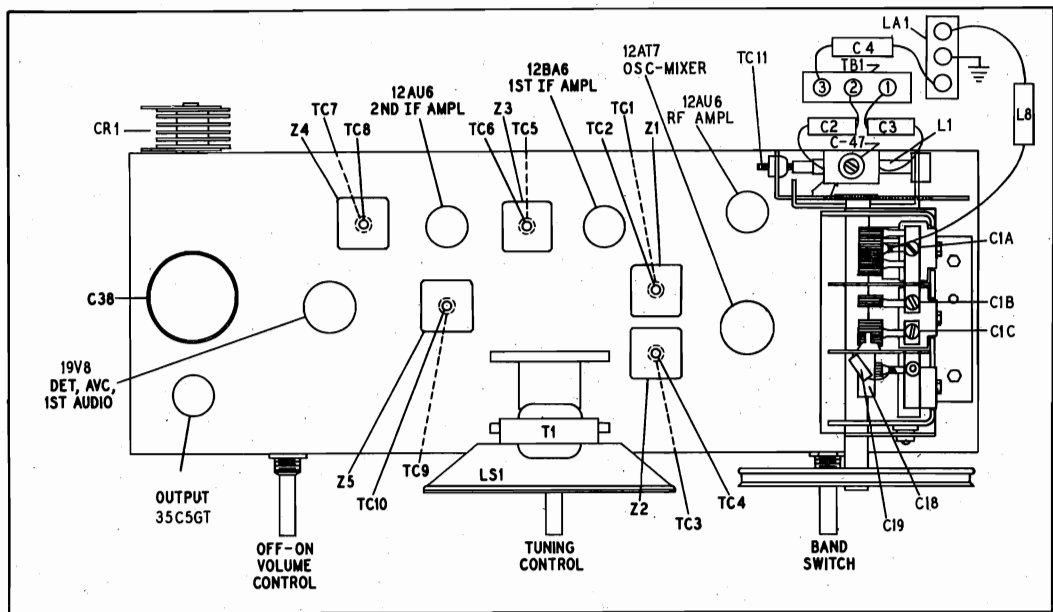

Figure 3. Top View, Showing Trimmer Locations

TP1-1762

FM ALIGNMENT CHART (Cont.)

STEP	SIGNAL GENERATOR		RADIO		ADJUST
	CONNECTION TO RADIO	DIAL SETTING	DIAL SETTING	SPECIAL INSTRUCTIONS	
2	Connect FM signal generator through a .01- μ f. condenser to FM tuning gang stator lug, junction of C1 and pin 4 of L2.	Same as step 1.	Same as step 1.	Adjust for maximum indication on scope as shown in figure 5.	TC6—FM 2nd i-f sec. TC5—FM 2nd i-f pri. TC2—FM 1st i-f sec. TC1—FM 1st i-f pri.
3	Connect FM signal generator to lug 2 of TB1, and ground side of generator to lug 3 of TB1. See note 1 below.	108.5 mc.	108.5 mc. (1st index mark from right).	Adjust for maximum indication on output meter.	C18—FM osc.
4	Same as step 3.	88 mc.	88 mc. (1st index mark from left).	Adjust for maximum indication on output meter. See note 2 below.	L5—FM osc.
5	Same as step 3.	105 mc.	105 mc. (3rd index mark from right).	Adjust for maximum indication on output meter while rocking tuning condenser.	C1B—FM r-f
6	Same as step 3.	105 mc.	105 mc.	Adjust for maximum indication on output meter.	C47—FM aerial.
7	Same as step 3.	92 mc.	92 mc. (3rd index mark from left).	Adjust for maximum indication on output meter. See note 3 below.	L2—FM r-f coil.
If L1 is replaced, adjust antenna inductance as follows:					
8	Same as step 3.	92 mc.	92 mc.	Adjust for maximum indication on output meter.	TC11—FM aerial.

NOTE 1: For proper and accurate results, the signal-generator output impedance must be 300 ohms to match the input impedance of TB1. If the signal-generator output impedance is less than 300 ohms, a resistor of the proper value may be used in series with the output lead to make the impedance correct. For example, if the output impedance is 150 ohms, place a 150-ohm resistor in series with the output lead.

NOTE 2: If oscillator frequency does not tune as low as 88 mc., compress the turns on the oscillator coil. If oscillator frequency tunes too low, spread the turns slightly. After coil is adjusted, repeat step 3.

NOTE 3: Check resonance of coil L2 by inserting end of a tuning wand, such as Philco Part No. 56-6100, in the coil. If output increases when iron end is placed in coil, compress turns slightly. If output increases when brass end is placed in coil, spread the turns. If output decreases when either end is placed in coil, no adjustment is necessary. After the coil is adjusted, readjust trimmer C1B and repeat steps 3 through 8 until no further adjustment is necessary.

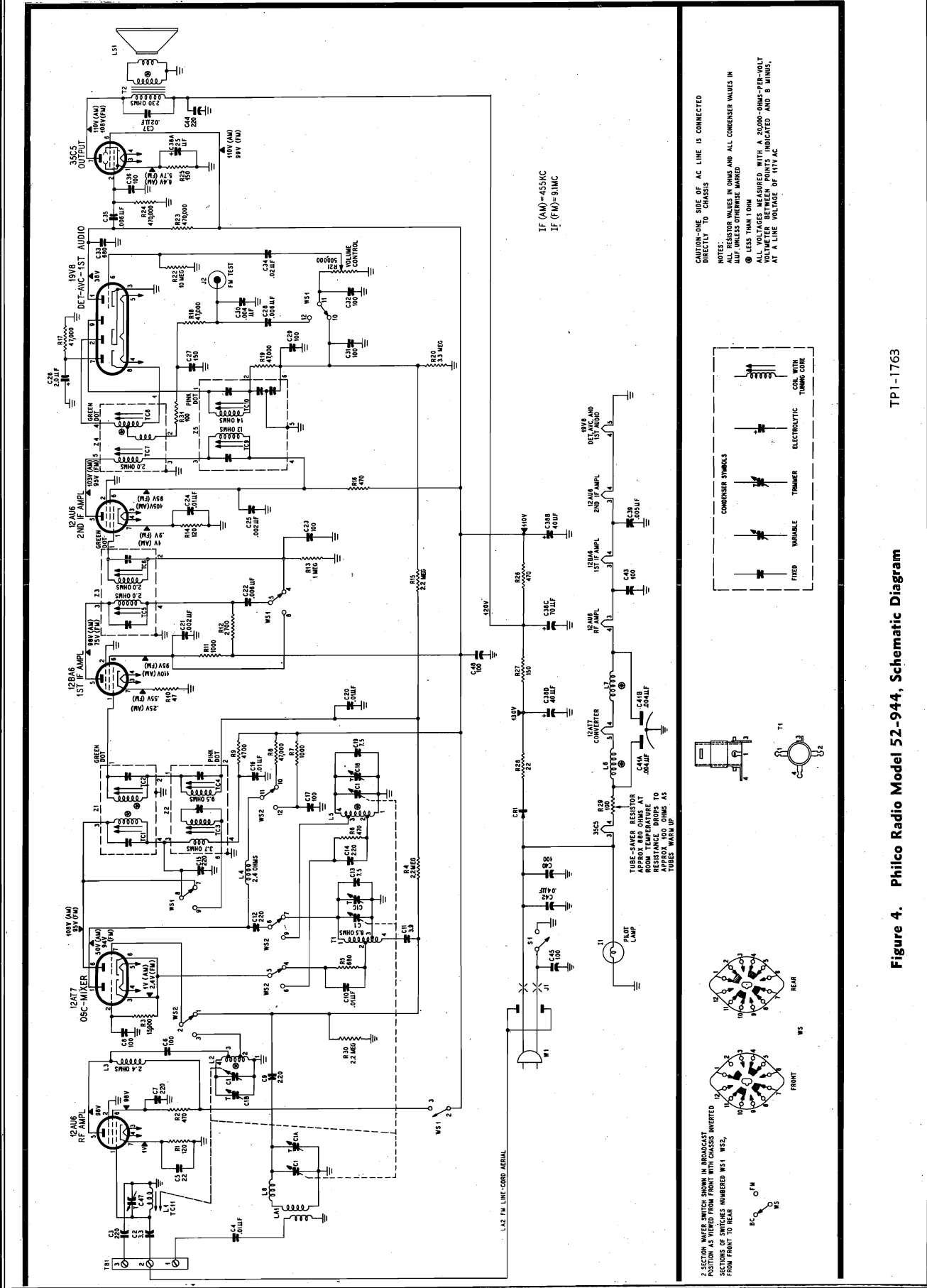

TP1-1763

Figure 4. Philco Radio Model 52-944, Schematic Diagram

PARTS LIST

NOTE: Part numbers identified by an asterisk (*) are general replacement items. These numbers may not be identical with those on factory parts; also, the electrical values of some replacement items may differ from the values indicated in the schematic diagram and parts list. The values substituted in any case are so chosen that the operation of the radio will be either unchanged or improved. When ordering replacements, use only the "Service Part No."

Reference Symbol	Description	Service Part No.	Reference Symbol	Description	Service Part No.
C1	Condenser, tuning gang, 5-section	31-2762	C47	Condenser, FM aerial trimmer	45-3034
C1A	Condenser, trimmer, BC aerial	Part of C1	CR1	Selenium rectifier, 100 ma., 117v	34-8003-1
C1B	Condenser, trimmer, FM r-f	Part of C1	I1	Pilot lamp, frosted, 117v, 7 watts	34-2605
C1C	Condenser, trimmer, BC oscillator	Part of C1	J1	Jack, male, a-c	27-4785-13
C2	Condenser, aerial isolating, 3.3 μ f.	30-1224-49	J2	Socket, FM test	27-6180
C3	Condenser, aerial isolating, 220 μ f.	62-122001001*	L1	Coil, FM aerial, complete with grommet	45-9613
C4	Condenser, aerial isolating, .01 μ f.	45-3505-41	L2	Coil, FM r-f	32-4415-2
C5	Condenser, cathode by-pass, 22 μ f.	62-022009001	L3	Choke, r-f, 3.3 μ h.	32-4422-10
C6	Condenser, d-c blocking, 100 μ f.	62-110001001	L4	Choke, r-f, 3.3 μ h.	32-4422-10
C7	Condenser, screen by-pass, 220 μ f.	62-122001011*	L5	Coil, FM oscillator	32-4414-1
C8	Condenser, oscillator grid, 100 μ f.	62-110001021*	L6	Choke, filament, 2.2 μ h.	32-4422-8
C9	Condenser, d-c blocking, 220 μ f.	62-122001001	L7	Choke, filament, 2.2 μ h.	32-4422-8
C10	Condenser, d-c blocking, .01 μ f.	30-1226-10	L8	Choke, r-f, 4.1 μ h.	32-4061-3
C11	Condenser, neutralizing, 3.9 μ f.	30-1221-14	LA1	AM loop and support assembly	76-7030
C12	Condenser, d-c blocking, 220 μ f.	62-122001001	LA2	Line-cord aerial, FM	Part of W1
C13	Condenser, fixed trimmer, temperature compensating, 7.5 μ f.	30-1224-8	LS1	Speaker, 4" p-m, including output transformer	36-1614-6
C14	Condenser, d-c blocking, 220 μ f.	62-122001001*	R1	Resistor, cathode bias, 120 ohms	66-1128340*
C15	Condenser, r-f by-pass, 220 μ f.	62-122001001*	R2	Resistor, screen decoupling, 470 ohms	66-1478340*
C16	Condenser, plate decoupling, .01 μ f.	30-4572	R3	Resistor, grid return, 15,000 ohms	66-3158340*
C17	Condenser, r-f by-pass, 100 μ f.	62-110001001*	R4	Resistor, grid return, 2.2 megohms	66-5228340*
C18	Condenser, trimmer, FM oscillator	31-6511	R5	Resistor, parasitic suppressor, 680 ohms	66-1688340*
C19	Condenser, fixed trimmer, temperature compensating, 7.5 μ f.	30-1224-8	R6	Resistor, parasitic suppressor, 470 ohms	66-1478340*
C20	Condenser, a-v-c decoupling, .01 μ f.	61-0120	R7	Resistor, plate dropping, FM, 1000 ohms	66-2108340*
C21	Condenser, screen by-pass, .002 μ f.	61-0062*	R8	Resistor, plate dropping, AM, 47,000 ohms	66-3478340*
C22	Condenser, neutralizing, .006 μ f.	45-3500-7*	R9	Resistor, plate dropping, 4700 ohms	66-2478340*
C23	Condenser, i-f by-pass, 100 μ f.	62-110001021*	R10	Resistor, cathode bias, 47 ohms	66-0478340*
C24	Condenser, cathode by-pass, .01 μ f.	61-0120	R11	Resistor, screen decoupling, 1000 ohms	66-2108340*
C25	Condenser, screen by-pass, .002 μ f.	61-0062*	R12	Resistor, plate decoupling, 2700 ohms	66-2278340*
C26	Condenser, electrolytic, diode-load filter, 2 μ f., 50v	30-2417-7	R13	Resistor, grid return, 1 megohm	66-5108340*
C27	Condenser, i-f by-pass, 150 μ f.	60-10155407	R14	Resistor, cathode bias, 120 ohms	66-1128340*
C28	Condenser, d-c blocking, .006 μ f.	45-3500-7*	R15	Resistor, a-v-c filter, 2.2 megohms	66-5228340*
C29	Condenser, i-f by-pass, 100 μ f.	62-110001021*	R16	Resistor, decoupling, 470 ohms	66-1478340*
C30	Condenser, de-emphasis, .004 μ f.	61-0179*	R17	Resistor, FM diode load, 47,000 ohms	66-3478340*
C31	Condenser, i-f by-pass, 100 μ f.	62-110001001*	R18	Resistor, de-emphasis, 47,000 ohms	66-3478340*
C32	Condenser, i-f by-pass, 100 μ f.	62-110001001*	R19	Resistor, i-f filter, 47,000 ohms	66-3478340*
C33	Condenser, plate by-pass, 680 μ f.	62-168001001	R20	Resistor, a-v-c load, 3.3 megohms	66-5338340*
C34	Condenser, d-c blocking, .02 μ f.	61-0108*	R21	Volume control (with off-on switch), 500,000 ohms	33-5566-20
C35	Condenser, d-c blocking, .006 μ f.	61-0105*	R22	Resistor, grid return, 10 megohms	66-4478340*
C36	Condenser, grid by-pass, 100 μ f.	62-110001001*	R23	Resistor, plate load, 470,000 ohms	66-4478340*
C37	Condenser, tone compensation, .02 μ f.	61-0108*	R24	Resistor, grid return, 470,000 ohms	66-4478340*
C38	Condenser, electrolytic, 4-section	30-2570-46	R25	Resistor, cathode bias, 150 ohms	66-1158340*
C38A	Condenser, cathode by-pass, 25 μ f., 25v.	Part of C38	R26	Resistor, filter, 470 ohms, 1 watt	66-1474340*
C38B	Condenser, filter, 40 μ f., 150v	Part of C38	R27	Resistor, filter, 150 ohms, 2 watts	66-1155340*
C38C	Condenser, filter, 70 μ f., 150v	Part of C38	R28	Resistor, current limiting, 22 ohms, 2 watts	66-0225360
C38D	Condenser, filter, 40 μ f., 150v	Part of C38	R29	Resistor, current limiting, 100 ohms	33-1343-3
C39	Condenser, filament by-pass, .005 μ f.	30-1238-1	R30	Resistor, grid return, 2.2 megohms	66-5228340*
C40	Condenser, line by-pass, 100 μ f.	62-110001021*	R31	Resistor, loading, 100 ohms	66-1108340*
C41	Condenser, ceramic, 2-section	30-1239	S1	Switch, off-on	Part of R21
C41A	Condenser, filament by-pass, .004 μ f.	Part of C41	T1	Transformer, AM oscillator	32-4458-4
C41B	Condenser, filament by-pass, .004 μ f.	Part of C41	T2	Transformer, output	Part of LS1
C42	Condenser, line by-pass, .04 μ f.	45-3500	W1	Line cord	L2183
C43	Condenser, filament by-pass, 100 μ f.	62-110001021*	W2	Cable, FM aerial, 72-ohm twin lead	41-3987
C44	Condenser, plate decoupling, 220 μ f.	66-122001001	WS	Switch, band, 2-wafer	42-1924-1
C45	Condenser, line by-pass, 100 μ f.	62-110001021*			
C46	Condenser, r-f by-pass, 100 μ f.	62-110001001			

PARTS LIST (Cont.)

Reference Symbol	Description	Service Part No.	MISCELLANEOUS (Cont.) Description	Service Part No.
Z1	Transformer, FM, 1st i-f	32-4518A	Dial backplate assembly	76-7040
Z2	Transformer, AM, 1st i-f	32-4516A	Drive cord, 25-foot spool	45-8750*
Z3	Transformer, FM, 2nd i-f	32-4518-1A	Pointer	56-5630-23FCP
Z4	Transformer, FM, 3rd i-f	32-4310-4A	Shaft, drive	56-7931FA11
Z5	Transformer, AM, 2nd i-f	32-4517A	Spring, gang drive	56-2617
			Spring, pointer drive	56-3167

MISCELLANEOUS

Description	Service Part No.	Description	Service Part No.
Cabinet	10796	Rubber mounts, gang (5)	27-4771-1
Back, flange, and socket assembly	76-5764	Rubber mounts, speaker (2)	54-4651-1
Fastener, back mtg. (4)	W-2235-FA9	Socket, 12BA6 (i-f ampl.)	27-6265
Baffle and cloth assembly	40-7923	Socket, 12AU6 (i-f ampl.)	27-6265
Fastener, baffle mtg. (2)	W-2235-2FA9	Socket, 12AU6 (r-f ampl.)	27-6275-1
Dial scale	54-5089-2	Socket, 12AT7	27-6203-6
Clip, scale mtg. (3)	56-7808FE11	Socket, 19V8	27-6203-5
Knob, FM-AM	54-4774-5	Socket, 35C5	27-6203-12
Knob, tuning	54-4774	Spacer, "T", speaker mtg. (2)	1W29155FA3
Knob, volume-off-on	54-4774-4	Washer, speaker mtg. (2)	1W52265FA9

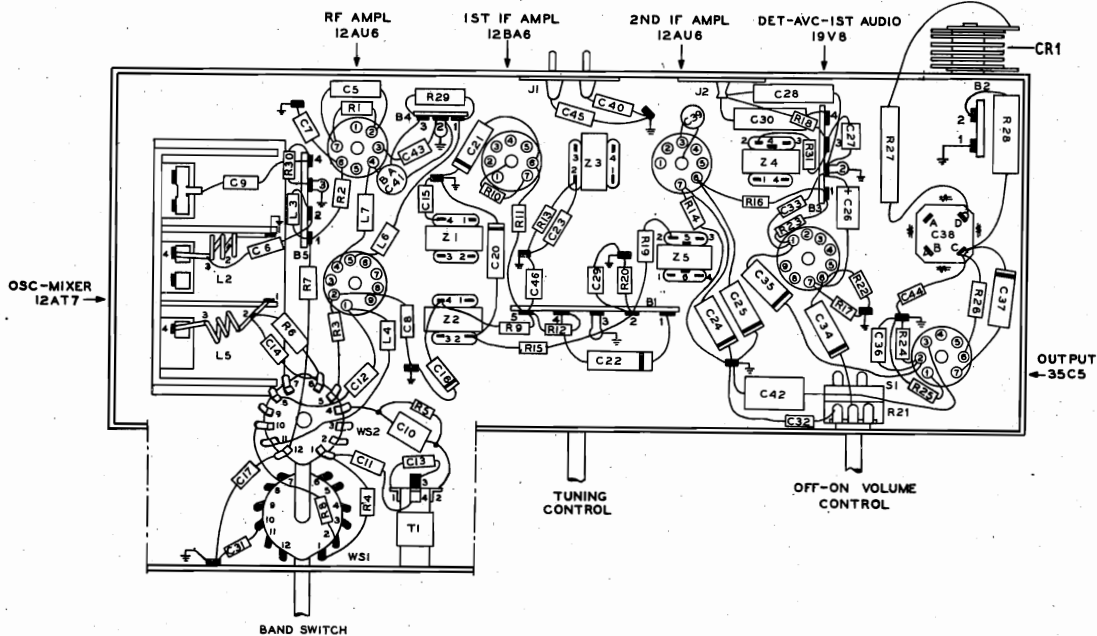

Figure 5. Symbolized Chassis, Showing Parts Placement

TP1-1761



MODEL 52-1340

TP1-1836

SPECIFICATIONS

CABINET	Molded plastic, mottled mahogany
CIRCUIT	Five-tube superheterodyne
FREQUENCY RANGE	540-1620 kc.
AUDIO OUTPUT	3 watts
OPERATING VOLTAGE	105—120 volts, 60 cycles, a.c.
POWER CONSUMPTION	
Radio Position	35 watts
Phonograph Position	60 watts
INTERMEDIATE FREQUENCY	455 kc.
AERIAL	Built-in high-impedance loop; provision for external aerial
PHILCO TUBES (5)	7A8 converter, 7B7 i-f amplifier, 7C6 2nd det. —a.v.c.—1st audio, 35L6GT output, 50Y7GT rectifier
PHONOGRAPH	Philco Model M-22 All-Speed Automatic Record Changer

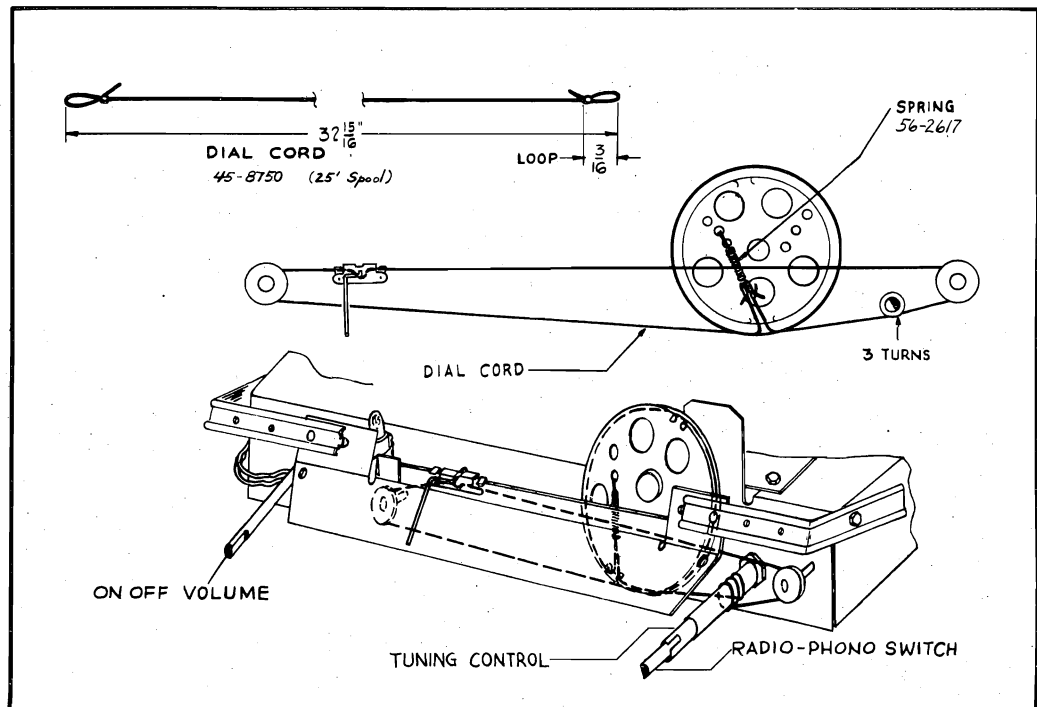

TP1-1835

Figure 1. Drive-Cord Installation Details

PR-1956

ALIGNMENT PROCEDURE

DIAL POINTER—Turn tuning condenser to full-mesh position. Set dial pointer to index mark, located to left of "55".

CONTROLS—Set volume control to maximum, radio-phono switch to RADIO position, and tuning control as indicated in chart.

OUTPUT METER—Connect across voice-coil terminals.

SIGNAL GENERATOR—Ground lead to B-, and output lead as indicated in chart.

OUTPUT LEVEL—During alignment, attenuate signal-generator output to hold output-meter indication below 1.25 volts.

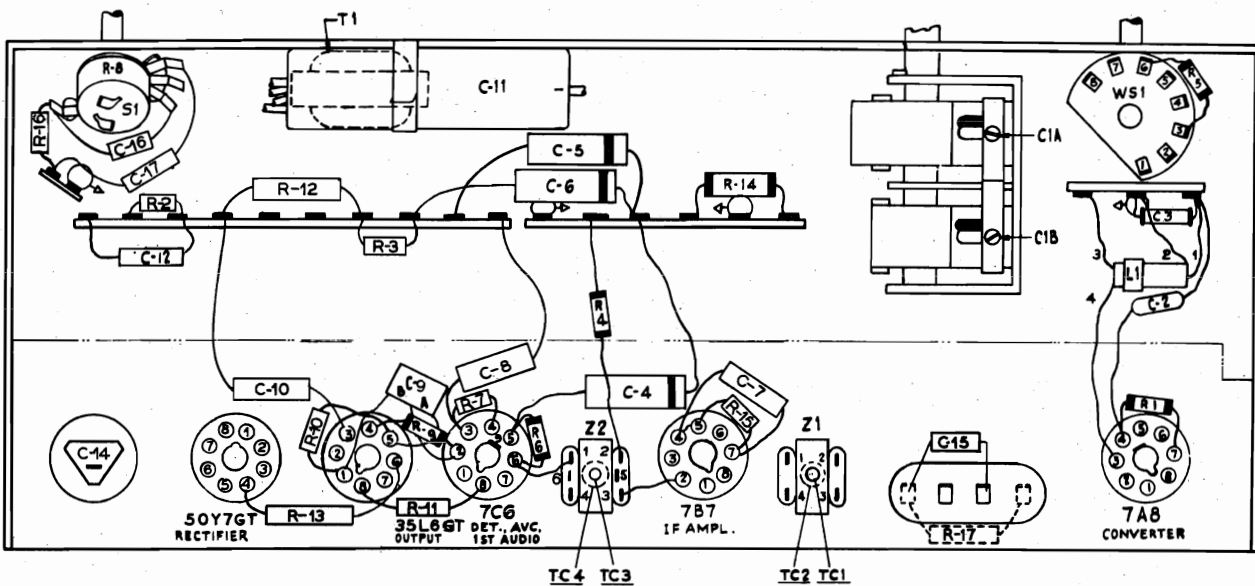

TP1-1837

Figure 2. Base View, Showing Parts Placement and Alignment Points

ALIGNMENT CHART

STEP	SIGNAL GENERATOR		RADIO		ADJUST TRIMMER
	CONNECTION TO RADIO	DIAL SETTING	DIAL SETTING	SPECIAL INSTRUCTIONS	
1	Through a .01- μ f. condenser to pin 6 of 7A8 converter tube.	455 kc.	Gang fully open.	Adjust, in order given, for maximum output. TC2 and TC4 are located at top of transformers.	TC4—2nd i-f sec TC3—2nd i-f pri. TC2—1st i-f sec. TC1—1st i-f pri.
2	Radiating loop (see note below).	1600 kc.	1600 kc.	Adjust for maximum.	C1B—osc. trimmer
3	Same as step 2.	1500 kc.	1500 kc.	Adjust for maximum.	C1A—ant. trimmer

RADIATING LOOP: Make up a 6 to 8 turn, 8-inch-diameter loop from insulated wire, connect to signal generator output leads, and place near radio loop.

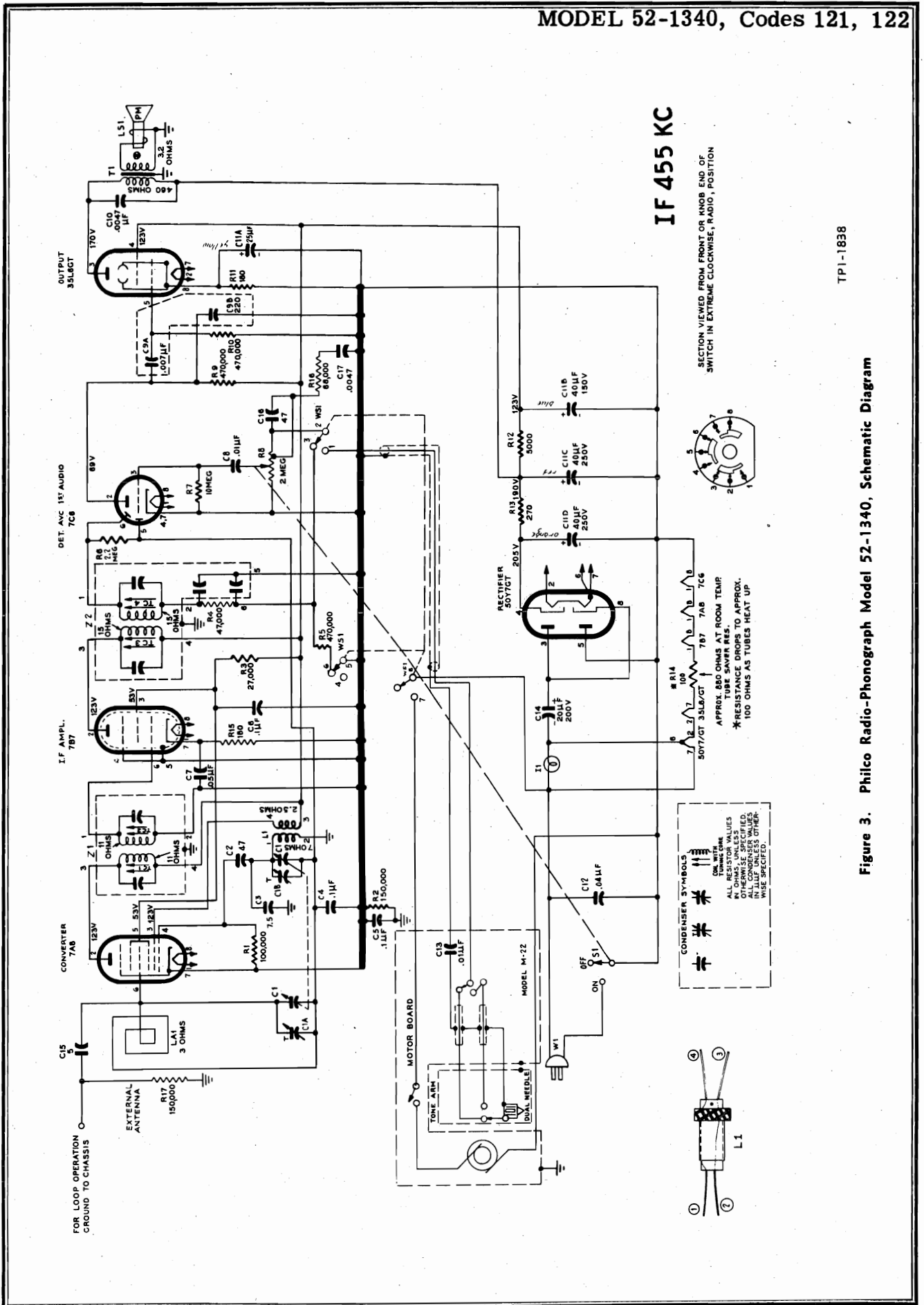

TPI-1838

Figure 3. Philco Radio-Phonograph Model 52-1340, Schematic Diagram

PARTS LIST

NOTE: Part numbers marked with an asterisk (*) are general replacement items. These numbers may not be identical with those on factory assemblies; also, the electrical values of some replacement items may differ from the values indicated in the schematic diagram and parts list. The values substituted in any case are so chosen that the operation of the receiver will be either unchanged or improved. When ordering replacements, use only the "Service Part No."

Reference Symbol	Description	Service Part No.
C1	Condenser, tuning gang	31-2751-9
C1A	Condenser, trimmer, aerial	Part of C1
C1B	Condenser, trimmer, osc.	Part of C1
C2	Condenser, osc. grid, d-c blocking, 47 μ f.	60-00515307*
C3	Condenser, temperature compensating, 7.5 μ f.	30-1224-65
C4	Condenser, a-v-c by-pass, .1 μ f.	61-0113*
C5	Condenser, by-pass, .1 μ f.	61-0113*
C6	Condenser, screen by-pass, .1 μ f.	61-0113*
C7	Condenser, cathode by-pass, .05 μ f.	61-0112
C8	Condenser, coupling, .01 μ f.	61-0120*
C9	Condenser, dual ceramic	30-1239-4
C9A	Condenser, d-c blocking, .007 μ f.	Part of C9
C9B	Condenser, r-f by-pass, 220 μ f.	Part of C9
C10	Condenser, tone compensation, .0047 μ f.	45-3505-56
C11	Condenser, electrolytic, 4-section	30-2575-32*
C11A	Condenser, cathode by-pass, 25 μ f.	Part of C11
C11B	Condenser, filter, 40 μ f.	Part of C11
C11C	Condenser, filter, 40 μ f.	Part of C11
C11D	Condenser, filter, 40 μ f.	Part of C11
C12	Condenser, line by-pass, .04 μ f.	30-1226-17
C13	Condenser, phono isolation, .01 μ f.	61-0120*
C14	Condenser, voltage doubling, 20 μ f. 200v.	30-2568-22
C15	Condenser, aerial blocking, 5 μ f.	30-1230
C16	Condenser, high-frequency compensation, 47 μ f.	60-00515307
C17	Condenser, bass compensation, .0047 μ f.	45-3505-56
I1	Pilot lamp, type 47	34-2064
L1	Coil, oscillator	32-4263
LA1	Loop antenna (Code 121)	76-2127-13
LA1	Loop antenna (Code 122)	76-2127-14
LS1	Speaker, 5/8" round	36-1639-1
R1	Resistor, grid return, 100,000 ohms	66-4108340*
R2	Resistor, leakage, 150,000 ohms	66-4158340*
R3	Resistor, dropping, 27,000 ohms	66-3278340*
R4	Resistor, i-f filter, 47,000 ohms	66-3478340*
R5	Resistor, diode return, 470,000 ohms	66-4478340*
R6	Resistor, diode load, 2.2 megohms	66-5228340*
R7	Resistor, grid return, 10 megohms	66-6108340*
R8	Volume control, 2 megohms (with switch) ..	33-5564-11
R9	Resistor, plate load, 470,000 ohms	66-4478340*

Reference Symbol	Description	Service Part No.
R10	Resistor, grid return, 470,000 ohms	66-4478340*
R11	Resistor, cathode bias, 180 ohms	66-1184340
R12	Resistor, filter, 5000 ohms	33-1335-95
R13	Resistor, filter, 270 ohms, 2 watts	33-1335-91
R14	Resistor, surge limiting, 880 ohms cold, 100 ohms hot	33-1343-3
R15	Resistor, cathode bias, 180 ohms	66-1188340
R16	Resistor, bass compensation, 68,000 ohms ..	66-3688340
R17	Resistor, aerial loading, 150,000 ohms	66-4158340
S1	Switch, off-on	Part of R8
T1	Transformer, output	32-8384*
W1	Line cord	L2183
WS1	Wafer switch, radio-phonograph	42-1949
Z1	Transformer, 1st i-f	32-4160A
Z2	Transformer, 2nd i-f	32-4240A

MISCELLANEOUS

Description	Service Part No.
Backplate assembly	76-6232
Cabinet, complete, Code 121	10840-2
Cabinet, complete, Code 122	10840-6
Hinge (2)	56-6603
Lid	54-4838
Lid support	56-6604
Changer Mounting Hardware	
Sleeve, rubber (3)	54-7798
Speed nut (3)	W-2554
Spring, heavy, top (3)	56-7059FA9
Spring, light, bottom (3)	56-7059-1FJ47
Dial scale	54-5107
Knob, off-on-volume	54-4843
Knob, radio-phonograph	54-4842
Knob, tuning	54-4841
Pilot-lamp socket assembly	76-1179-7
Fastener, pilot-lamp shield (2)	W2235-1FA9
Pointer	56-5630-31
Spring, pointer drive	56-2617
Socket, Loktal (3)	27-6207
Socket, octal (2)	27-6174
Tuning shaft	56-8370

SPECIFICATIONS

CABINET Molded phenolic
CIRCUIT Five-tube Superheterodyne (plus rectifier)
FREQUENCY RANGES
 Standard Broadcast 540—1620 kc.
 Special Services 1700—3400 kc.
AUDIO OUTPUT 1 watt
OPERATING VOLTAGE 117 volts, a.c.

POWER CONSUMPTION 30 watts
AERIAL High-impedance loop;
 connector for external aerial
INTERMEDIATE FREQUENCY 455 kc.
PHILCO TUBES 12BE6 converter, 12BA6 i-f amplifier,
 12AV6 det.—a.v.c.—1st audio,
 35C5 output, 35W4 rectifier



MODEL 53-700

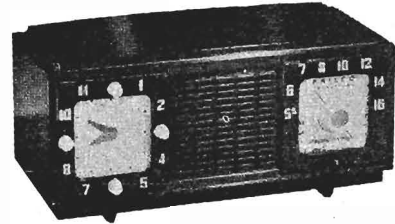

MODEL 53-701

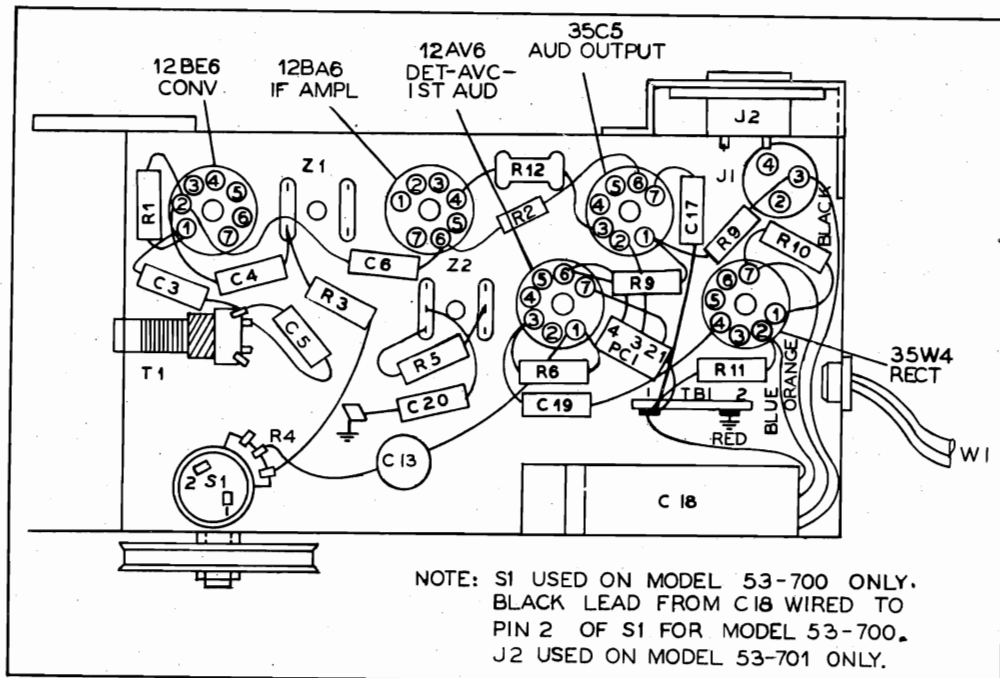

Figure 1. Base View, Showing Symbolized Chassis

TP2-1487

PR-2177

ALIGNMENT PROCEDURE

RADIO CONTROLS—Set volume control to maximum. Set tuning control and band switch as indicated in chart.

OUTPUT METER—Connect across voice-coil terminals.

SIGNAL GENERATOR—Connect generator and set frequency as indicated in chart. Use modulated output.

OUTPUT LEVEL—During alignment, adjust signal-generator output to hold output-meter reading below 1.25 volts.

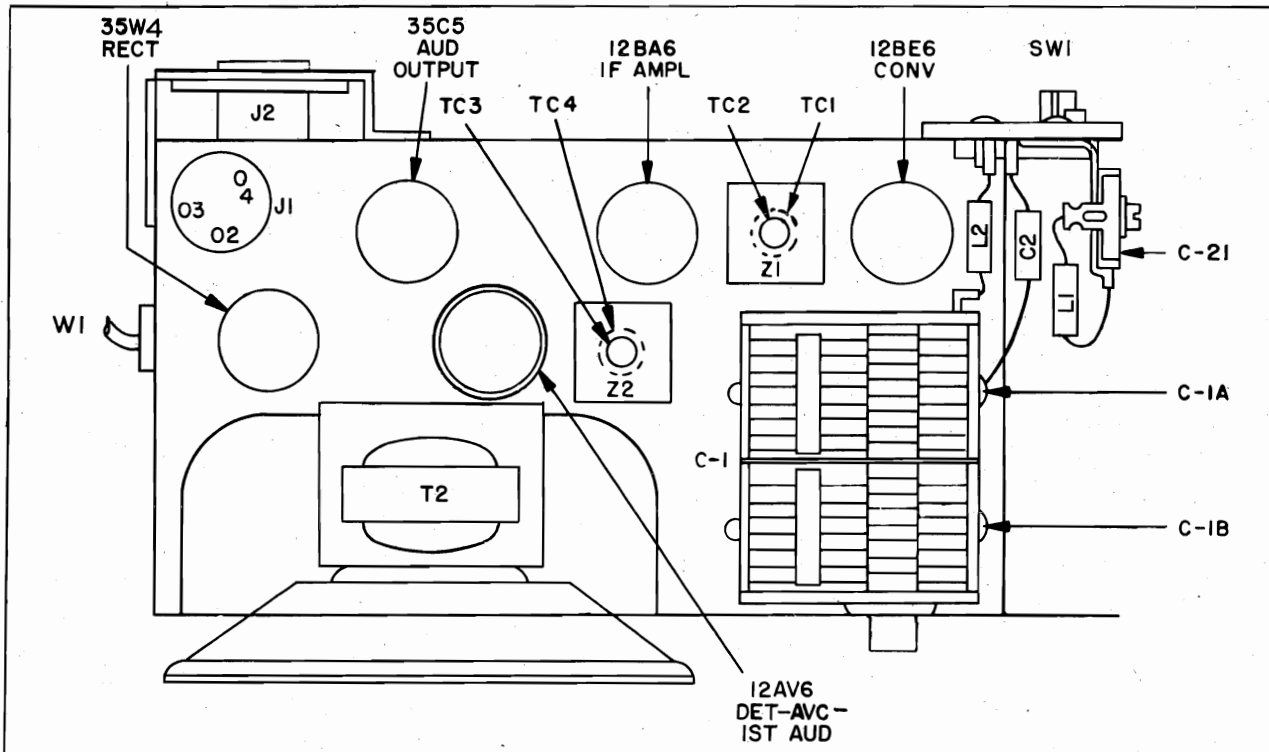

Figure 2. Top View, Showing Trimmer Locations

TP2-1488

ALIGNMENT CHART

STEP	SIGNAL GENERATOR		RADIO			ADJUST
	CONNECTION TO RADIO	DIAL SETTING	DIAL SETTING	BAND SWITCH SETTING	SPECIAL INSTRUCTIONS	
1	Ground lead to B-; output lead through a .1- μ f. condenser to grid (pin 7) of 12BE6.	455 kc.	Tuning gang fully open	Broadcast	Adjust tuning cores, in order given, for maximum output. (TC1 and TC3 are located at top of transformers.)	TC4—2nd i-f sec. TC3—2nd i-f pri. TC2—1st i-f sec. TC1—1st i-f pri.
2	Radiating loop (See note below).	1620 kc.	$^{\circ}$ 1620 kc.	Broadcast	Adjust trimmer for maximum output.	C1-B—osc.
3	Same as step 2.	1500 kc.	1500 kc.	Broadcast	Adjust trimmer for maximum output.	C1-A—aerial (broadcast)
4	Same as step 2.	3200 kc.	3200 kc.	Special Services	Adjust trimmer for maximum output.	C21—aerial (special services)

NOTE: Make up a 6–8 turn, 6-inch-diameter loop from insulated wire; connect to signal-generator leads, and place near radio loop.

$^{\circ}$ For proper adjustment of the oscillator trimmer, fully open the tuning gang and insert a .006-inch, non-metallic shim between the heel of the rotor and the top of the stator plates. Close the tuning gang sufficiently to hold the shim in place, and then remove the shim without disturbing the gang setting.

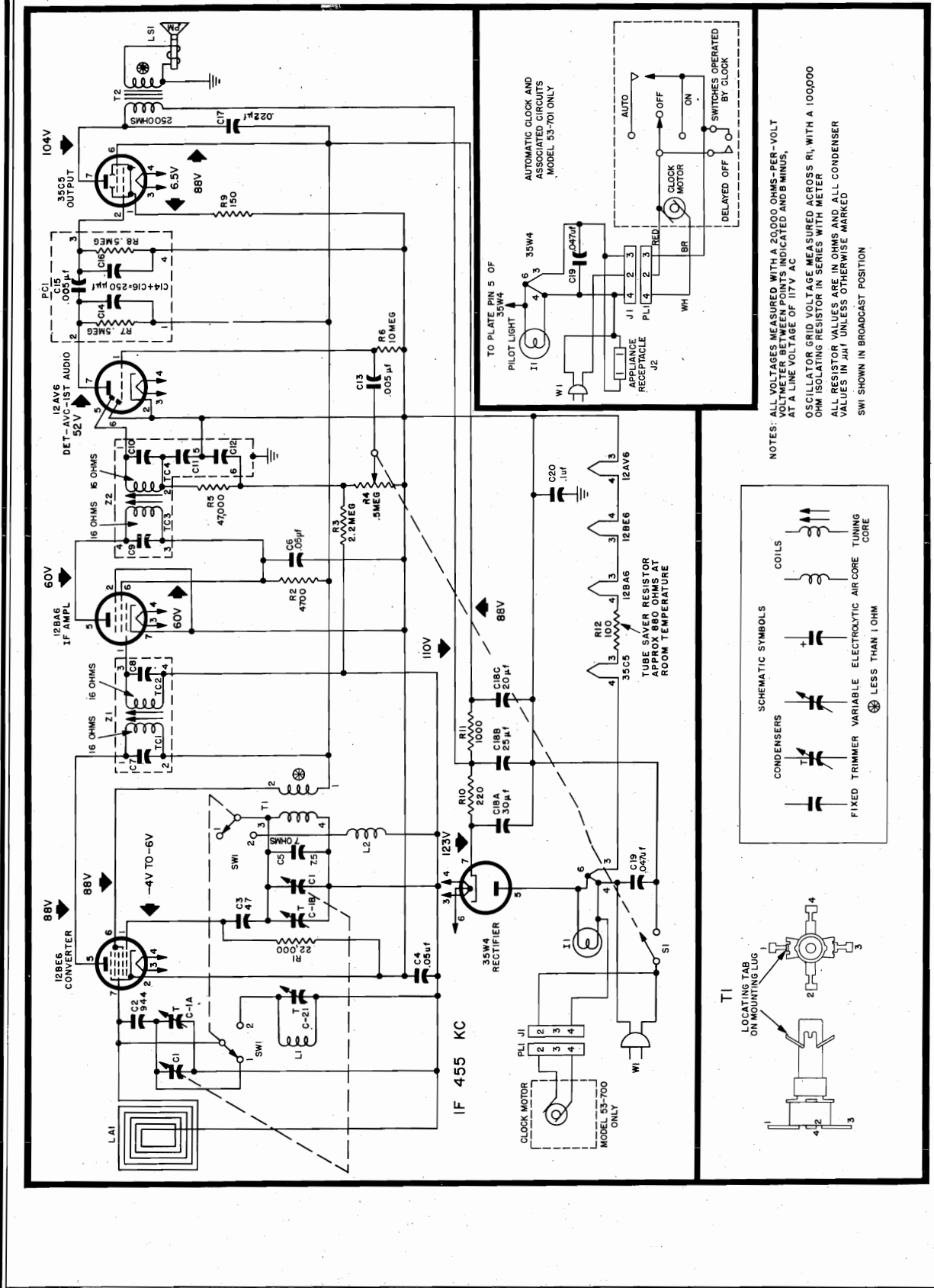

Figure 3. Philco Radio-Clock Models 53-700 and 53-701, Schematic Diagram

MODELS 53-700, 53-701

NOTE: Part numbers identified by an asterisk (*) are general replacement items. These numbers may not be identical with those on factory parts. Also, the electrical values of some replacement items may differ from the values indicated in the schematic diagram and parts list. The values substituted in any case are so chosen that the operation will be either unchanged or improved. When ordering replacements, use only the "Service Part No."

Reference Symbol	Description	Service Part No.
C1	Condenser, tuning gang	31-2751-13
C1A	Condenser, R-F trimmer	Part of C1
C1B	Condenser, oscillator trimmer	Part of C1
C2	Condenser, antenna series tracker, 944 μ f.	30-1220-65
C3	Condenser, oscillator grid, 47 μ f.	30-1230-4
C4	Condenser, a-v-c by-pass, .05 μ f.	45-3505-28*
C5	Condenser, drift compensation, 7.5 μ f.	30-1224-83
C6	Condenser, screen by-pass, .05 μ f.	45-3505-28*
C7	Condenser, i-f tuning	Part of Z1
C8	Condenser, i-f tuning	Part of Z1
C9	Condenser, i-f tuning	Part of Z2
C10	Condenser, i-f tuning	Part of Z2
C11	Condenser, detector filtering	Part of Z2
C12	Condenser, detector filtering	Part of Z2
C13	Condenser, audio coupling, .005 μ f.	30-1238-1
C14	Condenser, plate by-pass	Part of PC1
C15	Condenser, audio coupling, .005 μ f.	Part of PC1
C16	Condenser, compensating	Part of PC1
C17	Condenser, tone compensation, .022 μ f.	45-3505-43*
C18	Condenser, electrolytic, 3-section	
	Model 700	30-2575-34
	Model 701	30-2575-36
C18A	Condenser, filter, 30 μ f., 150v	Part of C18
C18B	Condenser, filter, 25 μ f., 150v	Part of C18
C18C	Condenser, filter, 20 μ f., 150v	Part of C18
C19	Condenser, line by-pass, .05 μ f.	45-3505-62*
C20	Condenser, B minus to chassis, .1 μ f.	45-3505-47*
C21	Condenser, trimmer, special services	31-6473-29
I1	Lamp, pilot	34-2068
J1	Jack, clock	27-6273
J2	Jack, appliance receptacle, a-c	76-3931
L1	Coil, aerial, special services	32-4561-3
L2	Coil, oscillator shunt	32-4562-2
LA1	Loop, part of cabinet back	76-7757
LS1	Speaker, p-m	36-1627-8
PL1	Plug, clock assembly	27-6273
R1	Resistor, oscillator grid, 22,000 ohms	66-3228340*
R2	Resistor, i-f screen dropping, 4700 ohms	66-2748340*
R3	Resistor, a-v-c filter, 2.2 megohms	66-5228340*
R4	Resistor, volume control, .5 megohm	
	Model 700	33-5566-41
	Model 701	33-5565
R5	Resistor, diode load, 47,000 ohms	66-3478340*

Reference Symbol	Description	Service Part No.
R6	Resistor, grid return, 10 megohms	66-6108340
R7	Resistor, plate load, 500,000 ohms	Part of PC1
R8	Resistor, grid return, 500,000 ohms	Part of PC1
R9	Resistor, cathode bias, 150 ohms	66-1158340*
R10	Resistor, B plus filter, 220 ohms	66-1224340*
R11	Resistor, B plus filter, 1000 ohms	66-2108340*
R12	Resistor, tube saver, 100 ohms	33-1343-3
S1	Switch, off-on	Part of R4
SW1	Switch, broadcast-special services	42-1796-2
T1	Transformer, oscillator	32-4453-6
T2	Transformer, output	32-8384*
W1	Line cord	L-2183*
Z1	Transformer, 1st i-f	32-4161A
Z2	Transformer, 2nd i-f	32-4240A

MISCELLANEOUS

Description	Service Part No.
Cabinet	
Model 53-700	10924
Model 53-700-I	10924-3
Model 53-701	10924-1
Model 53-701-I	10924-2
Knobs	
Model 53-700	
Clock	54-4983-1
Station selector	54-4978
Off-on	27-4815-10
Model 53-700-I	
Clock	54-4983
Station selector	54-4978
Off-on	27-4815-10
Model 53-701	
Clock (4)	54-4983-1
Station selector	54-4978
Off-on	27-4815-10
Model 53-701-I	
Clock (4)	54-4983
Station selector	54-4978
Off-on	27-4815-10
Clock	
Models 53-700 and 53-700-I	41-2041
Models 53-701 and 53-701-I	41-2041-1
Back-and-loop assembly	
Model 700	76-7757-1
Model 701	76-7757
Shield, tube	56-5629FA3
Clip, pilot lamp	W2563FA3
Socket, miniature (5)	27-6265
Socket assembly, pilot lamp	27-6233-6
Window, radio dial	54-4977

SPECIFICATIONS

CABINET Molded plastic
CIRCUIT Four-tube superheterodyne (plus rectifier)
FREQUENCY RANGES
 Standard broadcast 540-1620 kc.
 Special service 1700-3400 kc.
AUDIO OUTPUT 1 watt
OPERATING VOLTAGE 105-120 volts, a.c. or d.c.
POWER CONSUMPTION 30 watts
INTERMEDIATE FREQUENCY 455 kc.
AERIAL Magnecor high-impedance loop; provision for connecting external aerial
PHILCO TUBES 7A8 converter, 7B7 i-f amplifier, 7C6 2nd det.,
 avc., 1st audio, 50C5 output, 35W4 rectifier

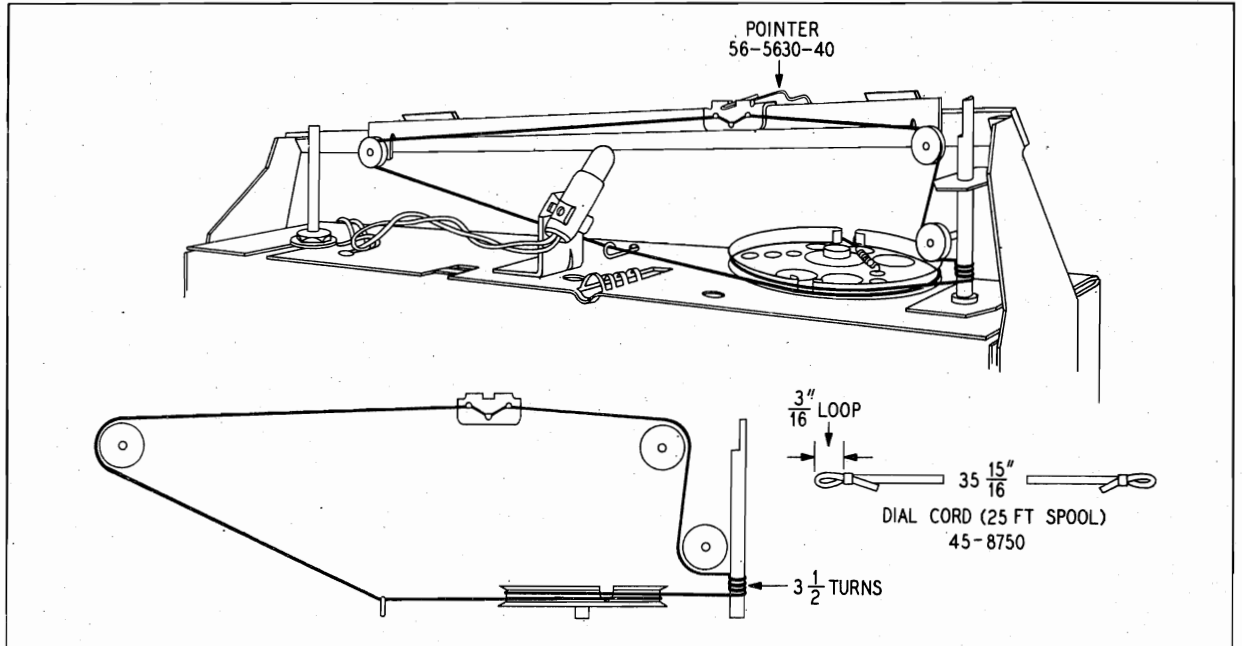
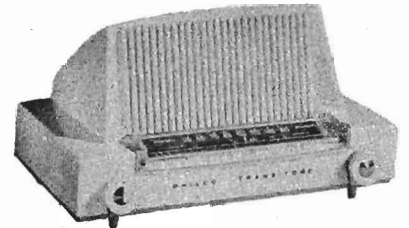

TP1-1839

Figure 1. Drive-Cord Installation Details

PR-2175

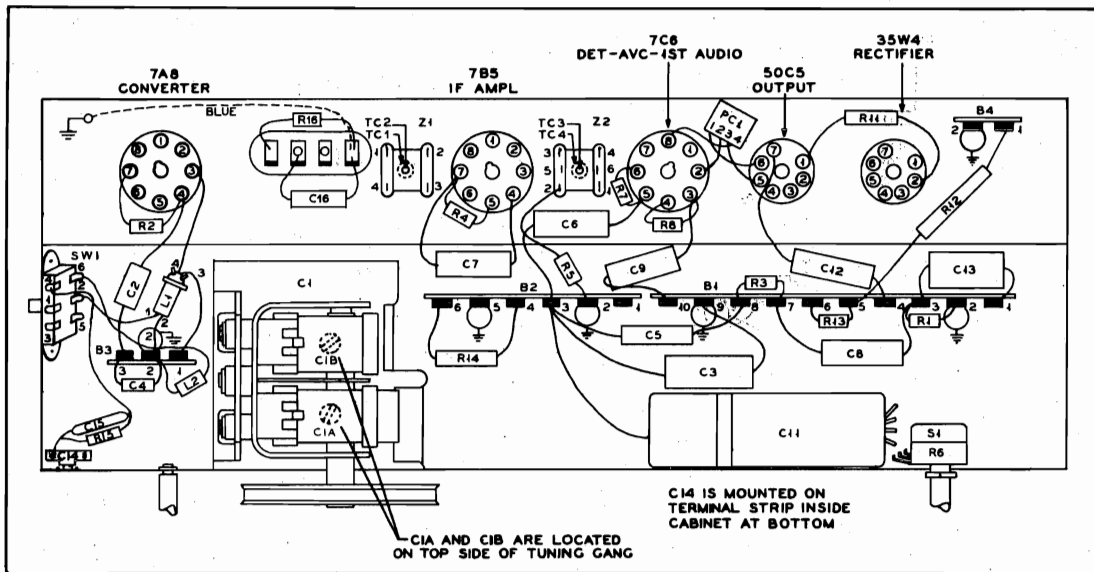

Figure 2. Base View, Showing Parts Placement and Alignment Points

TP2-946

ALIGNMENT PROCEDURE

DIAL POINTER—Turn tuning condenser to full-mesh position. Set dial pointer to index mark, located to the left of "55".

RADIO CONTROLS—Set volume control to maximum; set broadcast-special services switch, and tuning controls as indicated in chart.

OUTPUT METER—Connect across voice-coil terminals.

SIGNAL GENERATOR—Connect signal-generator ground lead to B-, and output lead as indicated in chart. Set frequency as indicated in chart. Use modulated output.

OUTPUT LEVEL—During alignment, attenuate signal-generator output to hold output-meter indication below 1.25 volts.

STEP	SIGNAL GENERATOR		RADIO		ADJUST TRIMMER
	CONNECTION TO RADIO	DIAL SETTING	DIAL SETTING	SPECIAL INSTRUCTIONS	
1	Through a .01- μ f. condenser to grid (pin 6) of 7A8 converter tube.	455 kc.	Gang fully open.	Set broadcast-special services switch to broadcast position. Adjust, in order given, for maximum output. TC1 and TC4 are located at top of transformers.	TC4—2nd i-f sec. TC3—2nd i-f pri. TC2—1st i-f sec. TC1—1st i-f pri.
2	Radiating loop (see note below).	1630 kc.	*1630 kc.	Adjust for maximum.	C1B—osc.
3	Same as step 2.	1500 kc.	1500 kc.	Adjust for maximum.	C1A—aerial.
4	Same as step 2.	3200 kc.	3200 kc.	Set broadcast-special services switch to special service position. Adjust for maximum.	C14—special services
5	Repeat steps 3 and 4.				

RADIATING LOOP: Make up a 6–8 turn, 8-inch-diameter loop from insulated wire, connect to signal-generator leads, and place near radio loop.

***NOTE:** For proper adjustment of the oscillator trimmer, fully open the tuning gang and insert a .006-inch, non-metallic shim between the heel of the rotor and the top of the stator plates. Close the tuning gang sufficiently to hold the shim in place, and then remove the shim without disturbing the gang setting.



MODEL 53-656



MODEL 53-658

SPECIFICATIONS

CABINET		POWER CONSUMPTION	
53-656	Molded plastic	A-c or d-c operation	15 watts
53-658	Covered, wooden	Battery operation	55 ma. at 9 volts, and 15 ma. at 90 volts
CIRCUIT Five-tube superheterodyne (plus selenium rectifier)		AERIAL Magnecor high-impedance loop; provision for connecting external aerial	
FREQUENCY RANGES		INTERMEDIATE FREQUENCY 265 kc.	
Standard broadcast	550—1600 kc.	PHILCO TUBES 1T4 r-f amplifier, 1R5 converter, 1U4 i-f amplifier, 1U5 det.—a.v.c.—1st audio 3V4 output	
Special services	1700—3400 kc.	BATTERY TYPE Philco P-274	
AUDIO OUTPUT 160 milliwatts			
OPERATING VOLTAGES 117 volts, a.c. or d.c.; or 9-volt "A" battery and 90-volt "B" battery			

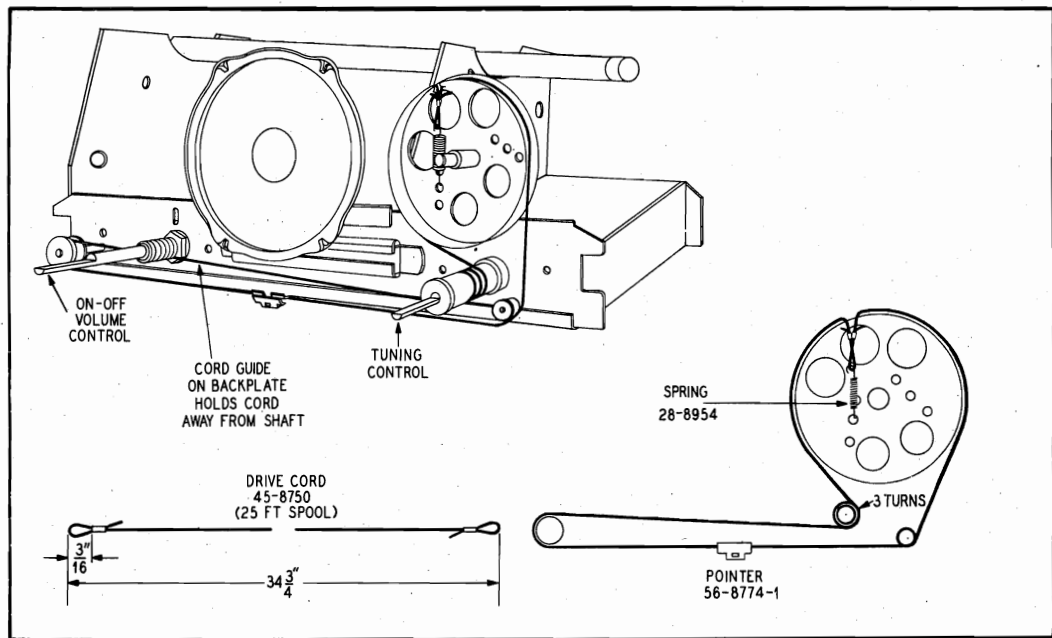

TP2-1392

Figure 1. Drive-Cord Installation Details

PR-2176

ALIGNMENT PROCEDURE

POINTER—Set pointer to coincide with first index mark from left side of dial backplate (looking at front of dial backplate).

RADIO CONTROLS—Set volume control to maximum; set broadcast-special services switch, SW1, as indicated in chart.

OUTPUT METER—Connect across voice-coil terminals.

SIGNAL GENERATOR—Use modulated output.

OUTPUT LEVEL—During alignment, adjust signal-

generator output to maintain output-meter indication below .5 volt.

CRITICAL LEAD DRESS—To secure proper padding capacity, the green lead from pin 6 of the 1R5 tube to Z1 must be dressed over the wiring panel, away from the chassis. The white lead which connects the low end of the aerial (LA1) to the broadcast-special services switch (SW1), must be dressed taut between the low-end tie lug and the retaining spring.

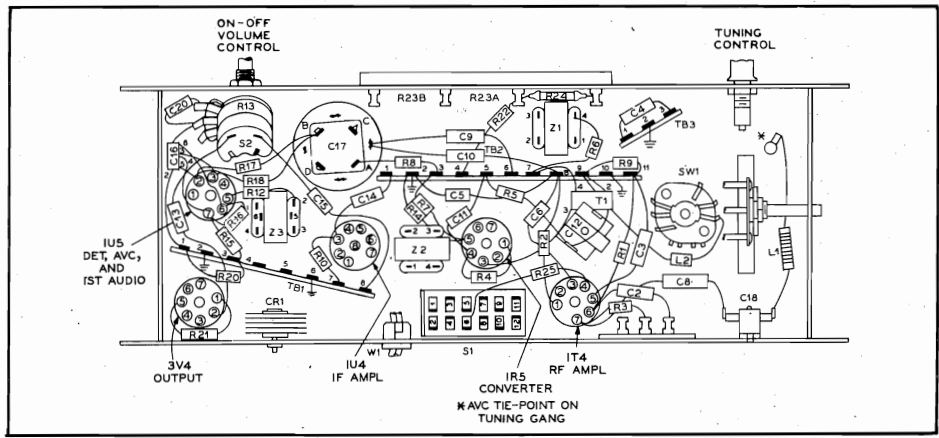

Figure 2. Top View, Showing Trimmer Locations

STEP	SIGNAL GENERATOR		RADIO		ADJUST TRIMMER
	CONNECTION TO RADIO	DIAL SETTING	DIAL SETTING	SPECIAL INSTRUCTIONS	
1	Through a .1- μ f. condenser to pin 6 of 1R5 converter.	265 kc.	1630 kc. (gang fully open)	Set broadcast-special services switch to broadcast position. Adjust, in order given, for maximum output.	TC5—2nd i-f sec. TC4—2nd i-f pri. TC2—1st i-f pri. TC3—1st i-f sec.
2	Radiating loop. See note below.	1630 kc.	*1630 kc. (gang fully open)	Adjust for maximum output. If low-frequency dial tracking is far off, make adjustments in steps 3 and 4 before making this adjustment.	C1B—osc. shunt
3	Same as step 2.	580 kc.	580 kc.	Adjust for maximum output while rocking tuning control.	C12—osc. series
4	Same as step 2.	580 kc.	580 kc.	Adjust for maximum output. This adjustment should not be made unless dial tracking is off, or sensitivity is low at low-frequency end (580 kc.).	TC1—r-f sec.
5	Same as step 2.	1500 kc.	1500 kc. (index mark at right)	Adjust, in order given, for maximum output.	C1A—r-f C19A—BC aerial
6	Repeat steps 3 and 5 until no further improvement is obtained.				
7	Same as step 2.	3000 kc.	3000 kc.	Set broadcast-special services switch to special services position. Adjust, in order given, for maximum output.	C19C—SS aerial C18—r-f
8	Same as step 2.	1900 kc.	1900 kc.	Adjust, in order given, for maximum output.	C19B—SS aerial series tracker
9	Repeat steps 7 and 8, and then repeat step 5.				

NOTE: Make up a six-to-eight-turn, 6-inch diameter loop using insulated wire; connect to signal-generator leads and place near radio loop.

*For proper adjustment of the oscillator trimmer, fully open the tuning gang and insert a .006-inch, non-metallic shim between the heel of the rotor and the top of the stator plates. Close the tuning gang sufficiently to hold the shim in place, and then remove the shim without disturbing the gang setting.

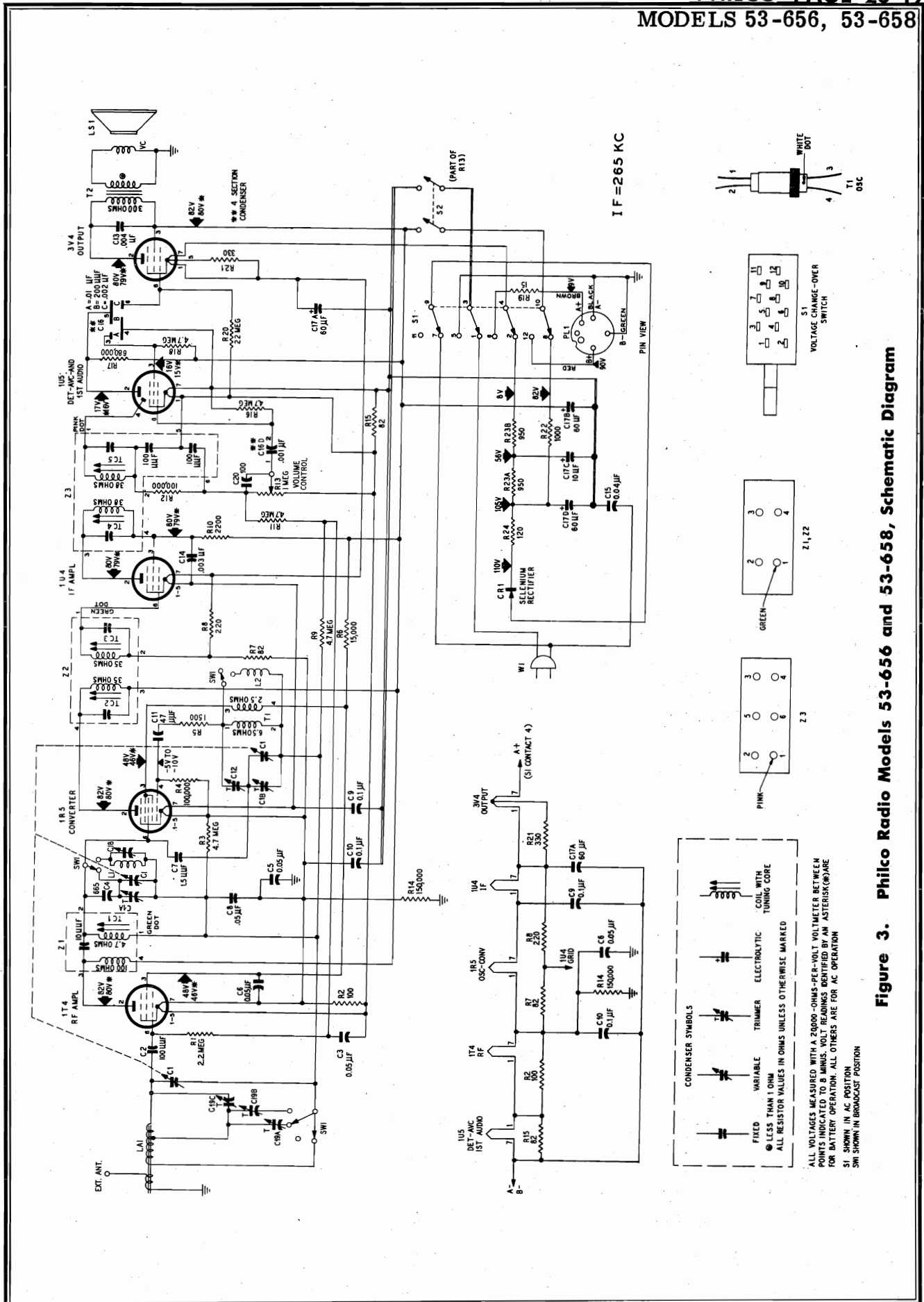
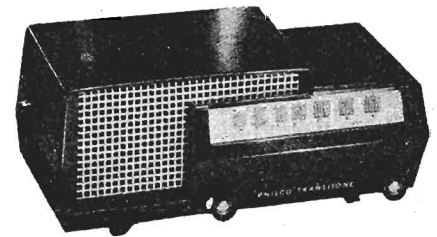

Figure 3. Philco Radio Models 53-656 and 53-658, Schematic Diagram

SPECIFICATIONS

CABINET MODEL 53-563 Molded plastic, ebony or Swedish red
CIRCUIT Four-tube superheterodyne (plus rectifier)
FREQUENCY RANGE
 Standard Broadcast 540 kc. to 1620 kc.
 Special Services 1700 kc. to 3400 kc.
AUDIO OUTPUT 1 watt
OPERATING VOLTAGE 105 to 120 volts, a.c. or d.c.
POWER CONSUMPTION 30 watts
AERIAL High-impedance loop
INTERMEDIATE FREQUENCY 455 kc.
PHILCO TUBES 12BE6 converter, 12BA6 i-f amplifier, 12AV6 det.—
 a.v.c.-1st audio, 35C5 output, 35W4 rectifier



MODEL 53-563

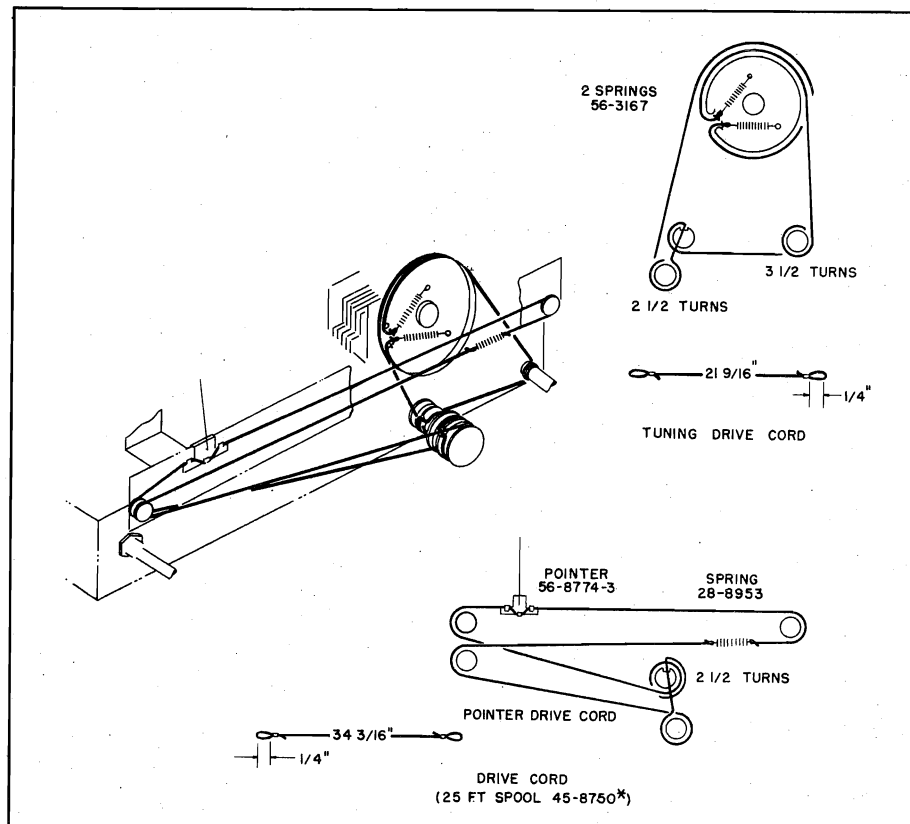

TP2-1371

Figure 1. Dial-Cord Installation Details

PR-2174

ALIGNMENT PROCEDURE

RADIO CONTROLS—Set volume control to maximum. Set tuning control and band switch, SW1, as indicated in chart.

OUTPUT METER—Connect across voice-coil terminals.

SIGNAL GENERATOR—Connect generator and set frequency as indicated in chart. Use modulated output.

OUTPUT LEVEL—During alignment, adjust signal-generator output to hold output-meter reading below 1.25 volts.

STEP	SIGNAL GENERATOR		RADIO			ADJUST
	CONNECTION TO RADIO	DIAL SETTING	DIAL SETTING	BAND SWITCH SETTING	SPECIAL INSTRUCTIONS	
1	Ground lead to B-; output lead through a .1- μ f. condenser to grid (pin 7) of 12BE6.	455 kc.	Tuning gang fully open	Broadcast	Adjust tuning cores, in order given, for maximum output. TC1 and TC3 are located at top of transformers.	TC4—2nd i-f sec. TC3—2nd i-f pri. TC2—1st i-f sec. TC1—1st i-f pri.
2	Radiating loop (See note below).	1620 kc.	*1620 kc.	Broadcast	Adjust trimmer for maximum output.	C1-B—osc.
3	Same as step 2.	1500 kc.	1500 kc.	Broadcast	Adjust trimmer for maximum output.	C1-A—aerial (broadcast)
4	Same as step 2.	3200 kc.	3200 kc.	Special Services	Adjust trimmer for maximum output.	C21—aerial (special services).

NOTE: Make up a 6—8 turn, 6-inch-diameter loop from insulated wire, connect to signal-generator leads, and place near radio loop. The 1620-kc. index mark is located on the pointer rail, to the extreme right side as viewed from the front.

*For proper adjustment of the oscillator trimmer, fully open the tuning gang and insert a .006-inch non-metallic shim between the heel of the rotor and the top of the stator plates. Close the tuning gang sufficiently to hold the shim in place, and then remove the shim without disturbing the gang setting.

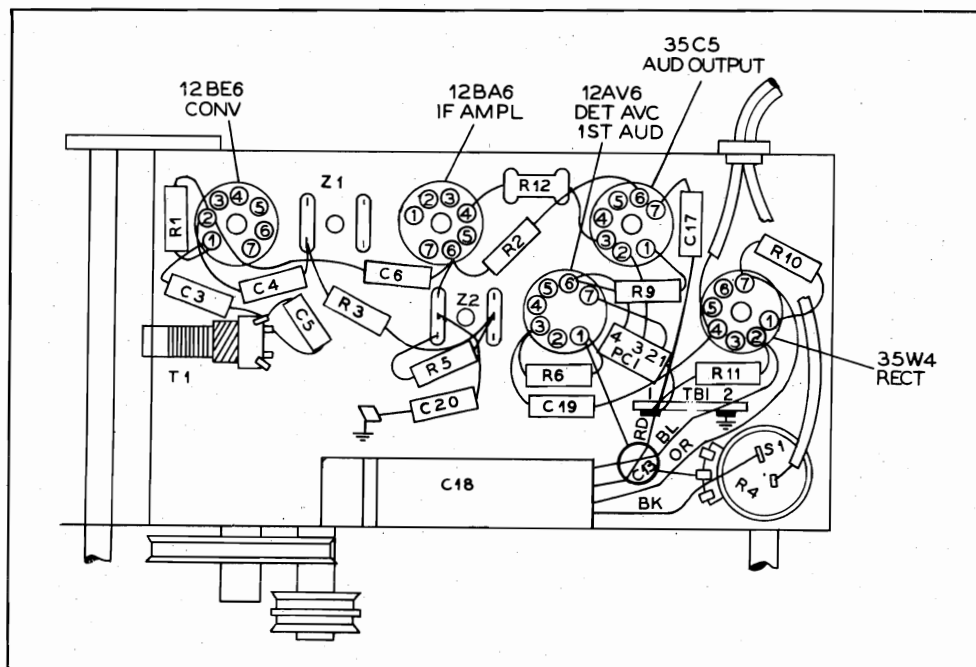

TP2-1372

Figure 2. Base View, Showing Symbolized Chassis

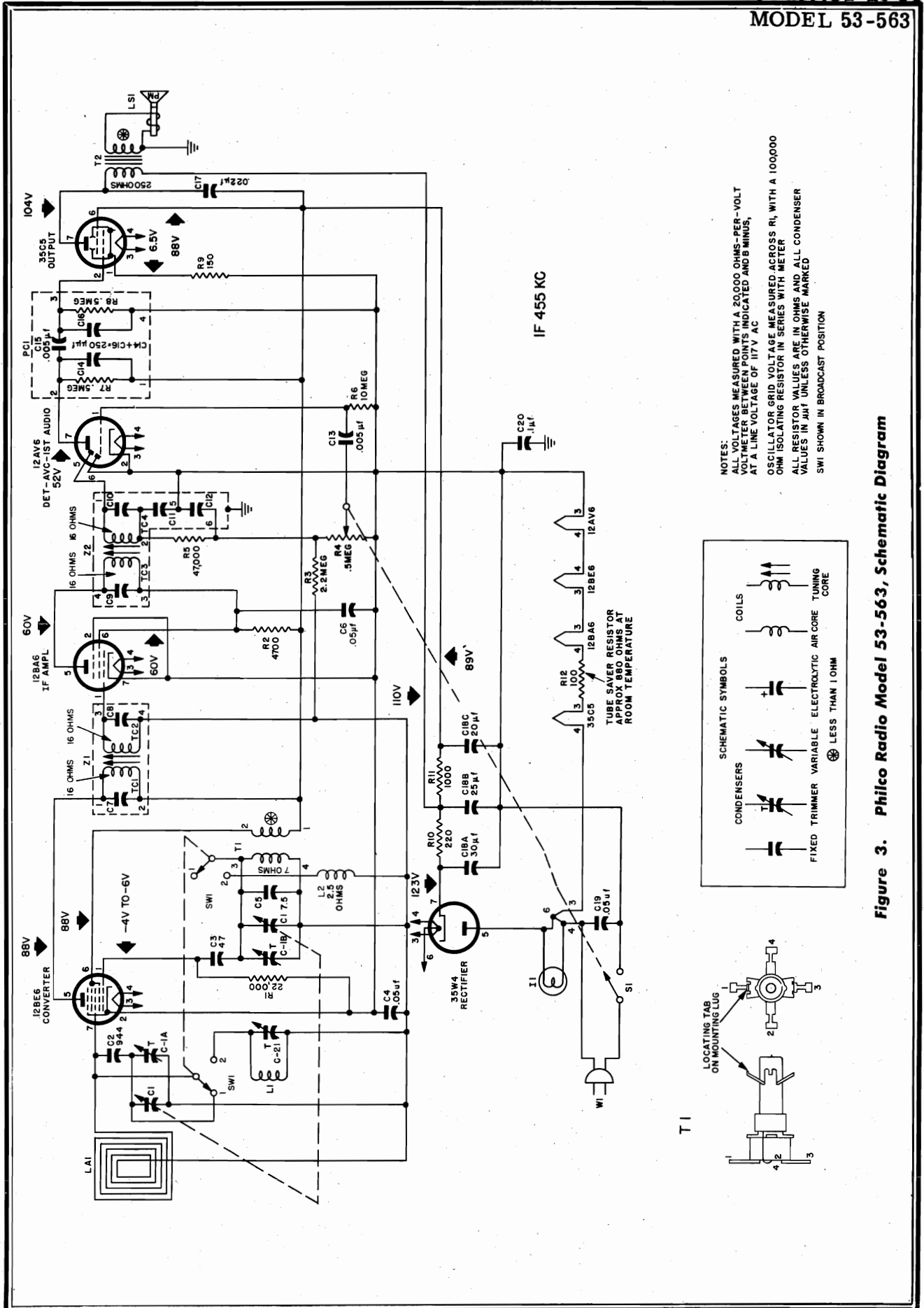
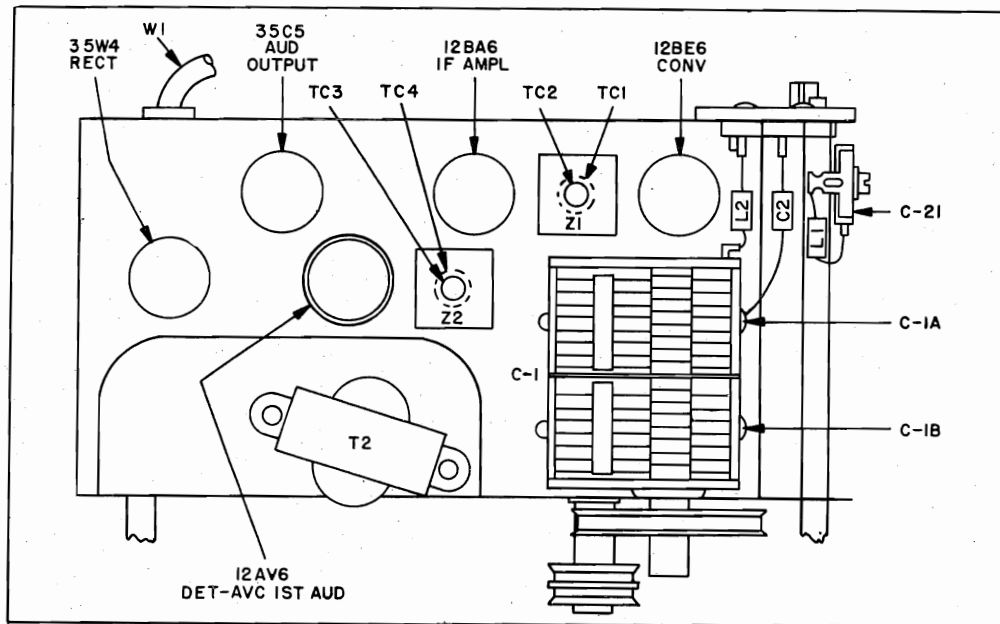

Figure 3. Philco Radio Model 53-563, Schematic Diagram



TP2-1374

Figure 4. Top View, Showing Trimmer Locations

PARTS LIST

NOTE: Part numbers identified by an asterisk (*) are general replacement items. These numbers may not be identical with those on factory parts. Also, the electrical values of some replacement items may differ from the values indicated in the schematic diagram and parts list. The values substituted in any case are so chosen that the operation will be either unchanged or improved. When ordering replacements, use only the "Service Part No."

Reference Symbol	Description	Service Part No.
C1	Condenser, tuning gang	31-2751-14
C1A	Condenser, aerial trimmer	Part of C1
C1B	Condenser, oscillator trimmer	Part of C1
C2	Condenser, antenna series tracker, 944 $\mu\text{f.}$	30-1220-65
C3	Condenser, oscillator grid, 47 $\mu\text{f.}$	30-1230-4
C4	Condenser, a-v-c by-pass, .05 $\mu\text{f.}$	45-3505-28*
C5	Condenser, drift compensation, 7.5 $\mu\text{f.}$	30-1224-83
C6	Condenser, screen by-pass, .05 $\mu\text{f.}$	45-3505-28*
C7	Condenser, i-f tuning	Part of Z1
C8	Condenser, i-f tuning	Part of Z1
C9	Condenser, i-f tuning	Part of Z2
C10	Condenser, i-f tuning	Part of Z2
C11	Condenser, detector filtering	Part of Z2
C12	Condenser, detector filtering	Part of Z2
C13	Condenser, audio coupling, .005 $\mu\text{f.}$	30-1238-1
C14	Condenser, plate by-pass	Part of PC1
C15	Condenser, audio coupling, .005 $\mu\text{f.}$	Part of PC1
C16	Condenser, compensating	Part of PC1
C17	Condenser, tone compensation, .022 $\mu\text{f.}$	45-3505-43*
C18	Condenser, electrolytic, 3-section	30-2573
C18A	Condenser, filter, 30 $\mu\text{f.}$, 150v	Part of C18
C18B	Condenser, filter, 25 $\mu\text{f.}$, 150v	Part of C18
C18C	Condenser, filter, 20 $\mu\text{f.}$, 150v	Part of C18
C19	Condenser, line by-pass, .05 $\mu\text{f.}$	45-3505-62*
C20	Condenser, B minus to chassis, .1 $\mu\text{f.}$	45-3505-47*
C21	Condenser, trimmer, special services	31-6473-29
I1	Lamp, pilot	34-2068
L1	Coil, aerial, special services	32-4561-3
L2	Coil, oscillator shunt	32-4562-2
LA1	Loop, part of cabinet back	76-7764
LS1	Speaker, p-m	36-1627-5
R1	Resistor, oscillator grid, 22,000 ohms	66-3228340*
R2	Resistor, i-f screen dropping, 4700 ohms	66-2748340*
R3	Resistor, a-v-c filter, 2.2 megohms	66-5228340*
R4	Resistor, volume control, .5 megohm	33-5566-41
R5	Resistor, diode load, 47,000 ohms	66-3478340*

Reference Symbol	Description	Service Part No.
R6	Resistor, grid return, 10 megohms	66-6108340*
R7	Resistor, plate load, 500,000 ohms	Part of PC1
R8	Resistor, grid return, 500,000 ohms	Part of PC1
R9	Resistor, cathode bias, 150 ohms	66-1158340*
R10	Resistor, B plus filter, 220 ohms	66-1224340*
R11	Resistor, B plus filter, 1000 ohms	66-2108340*
R12	Resistor, tube saver, 100 ohms	33-1343-3
S1	Switch, off-on	Part of R4
SW1	Switch, broadcast-special services	42-1796-2
T1	Transformer, oscillator	32-4453-6
T2	Transformer, output	32-8384*
W1	Line cord	L-2183*
Z1	Transformer, 1st i-f	32-4161A
Z2	Transformer, 2nd i-f	32-4240A

MISCELLANEOUS

Description	Service Part No.
Cabinet, ebony	10918-1
Cabinet, Swedish red	10918-3
Back and-loop assembly	76-7764
Grille (plastic)	54-4966
Dial backplate (plastic)	54-4968
Drive cord, 25-foot spool	45-8750
Knob, red	54-4527-38
Knob, ebony	54-4527-37
Pointer, dial	56-8774-3
Painter rail, bracket-and-pulley assembly	76-7767
Shaft, tuning	56-9807
Socket assembly, pilot lamp	27-6233-6*
Socket, 7-pin miniature	27-6265*
Spring, retaining	28-8610*
Spring	56-3167
Spring	28-8953

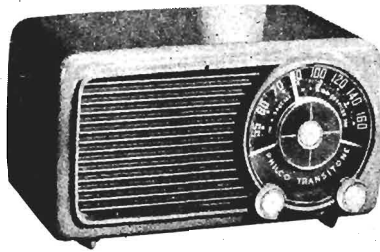

MODEL 53-561

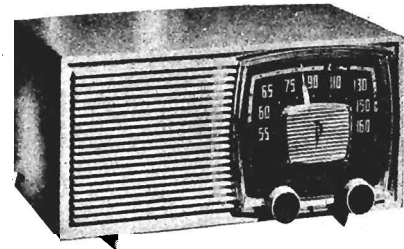

MODEL 53-564

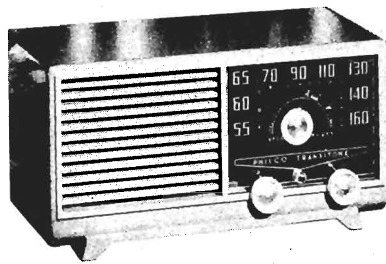

MODEL 53-562

SPECIFICATIONS

OPERATING VOLTAGE	105 to 120 volts, a.c. or d.c.
POWER CONSUMPTION	30 watts
AERIAL	High-impedance loop
INTERMEDIATE FREQUENCY	455 kc.
PHILCO TUBES	12BE6 converter, 12BA6 i-f amplifier, 12AV6 det.-a.v.c.-1st audio, 35C5 output, 35W4 rectifier
CABINET	Molded plastic
CIRCUIT	Four-tube superheterodyne (plus rectifier)
FREQUENCY RANGE	
Standard Broadcast	540 kc. to 1620 kc.
Special Services	1700 kc. to 3400 kc.
AUDIO OUTPUT	1 watt

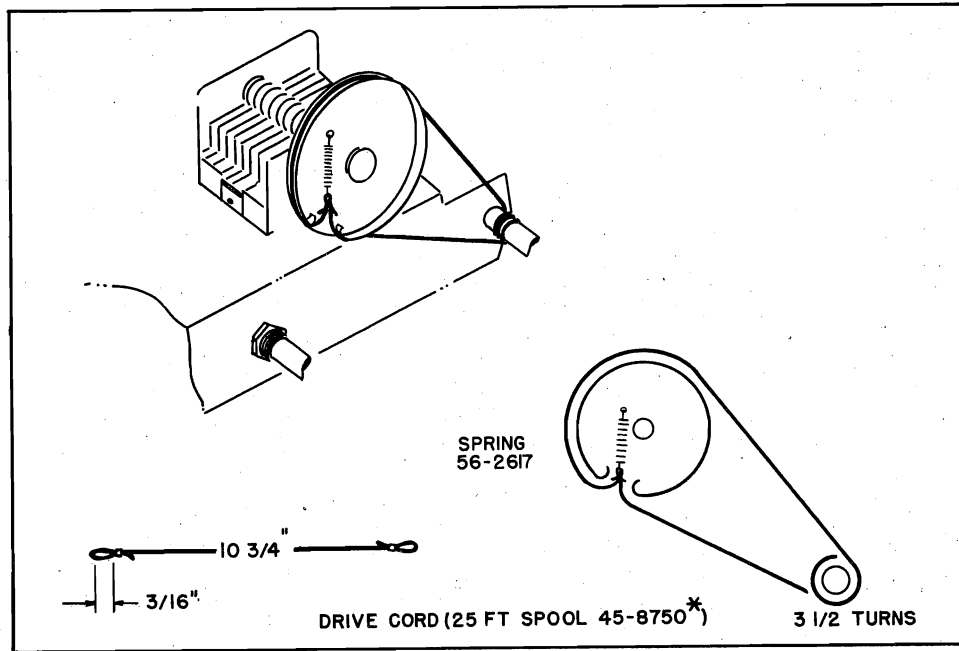

TP2-1405

Figure 1. Dial-Cord Installation Details

ALIGNMENT PROCEDURE

RADIO CONTROLS—Set volume control to maximum. Set tuning control and band switch, SW1, as indicated in chart.

OUTPUT METER—Connect across voice-coil terminals.

SIGNAL GENERATOR—Connect generator and set fre-

quency as indicated in chart. Use modulated output.

OUTPUT LEVEL—During alignment, adjust signal-generator output to hold output-meter reading below 1.25 volts.

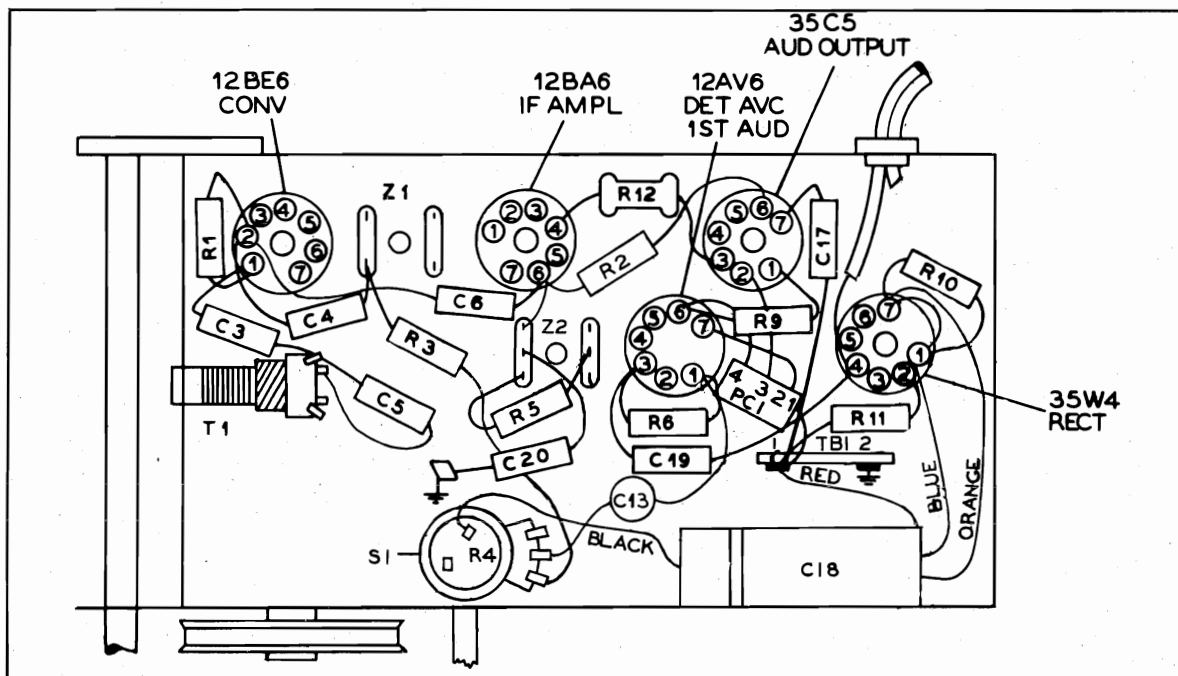

Figure 2. Base View, Showing Symbolized Chassis

TP2-1406

STEP	SIGNAL GENERATOR		RADIO			ADJUST
	CONNECTION TO RADIO	DIAL SETTING	DIAL SETTING	BAND SWITCH SETTING	SPECIAL INSTRUCTIONS	
1	Ground lead to B-; output lead through a .1- μ f. condenser to grid (pin 7) of 12BE6.	455 kc.	Tuning gang fully open.	Broadcast	Adjust tuning cores, in order given, for maximum output. (TC1 and TC3 are located at top of transformers).	TC4—2nd i-f sec. TC3—2nd i-f pri. TC2—1st i-f sec. TC1—1st i-f pri.
2	Radiating loop (see NOTE below).	1620 kc.	\approx 1620 kc.	Broadcast	Adjust trimmer for maximum output.	C1-B osc.
3	Same as step 2.	1500 kc.	1500 kc.	Broadcast	Adjust trimmer for maximum output.	C1-A aerial (broadcast).
4	Same as step 2.	3200 kc.	3200 kc.	Special services	Adjust trimmer for maximum output.	C-21—aerial (special services).

NOTE: Make up a 6-8 turn, 6-inch-diameter loop from insulated wire; connect to signal-generator leads and place near radio loop.

*For proper adjustment of the oscillator trimmer, fully open the tuning gang and insert a .006-inch non-metallic shim between the heel of the rotor and the top of the stator plates. Close the tuning gang sufficiently to hold the shim in place, and then remove the shim without disturbing the gang setting.

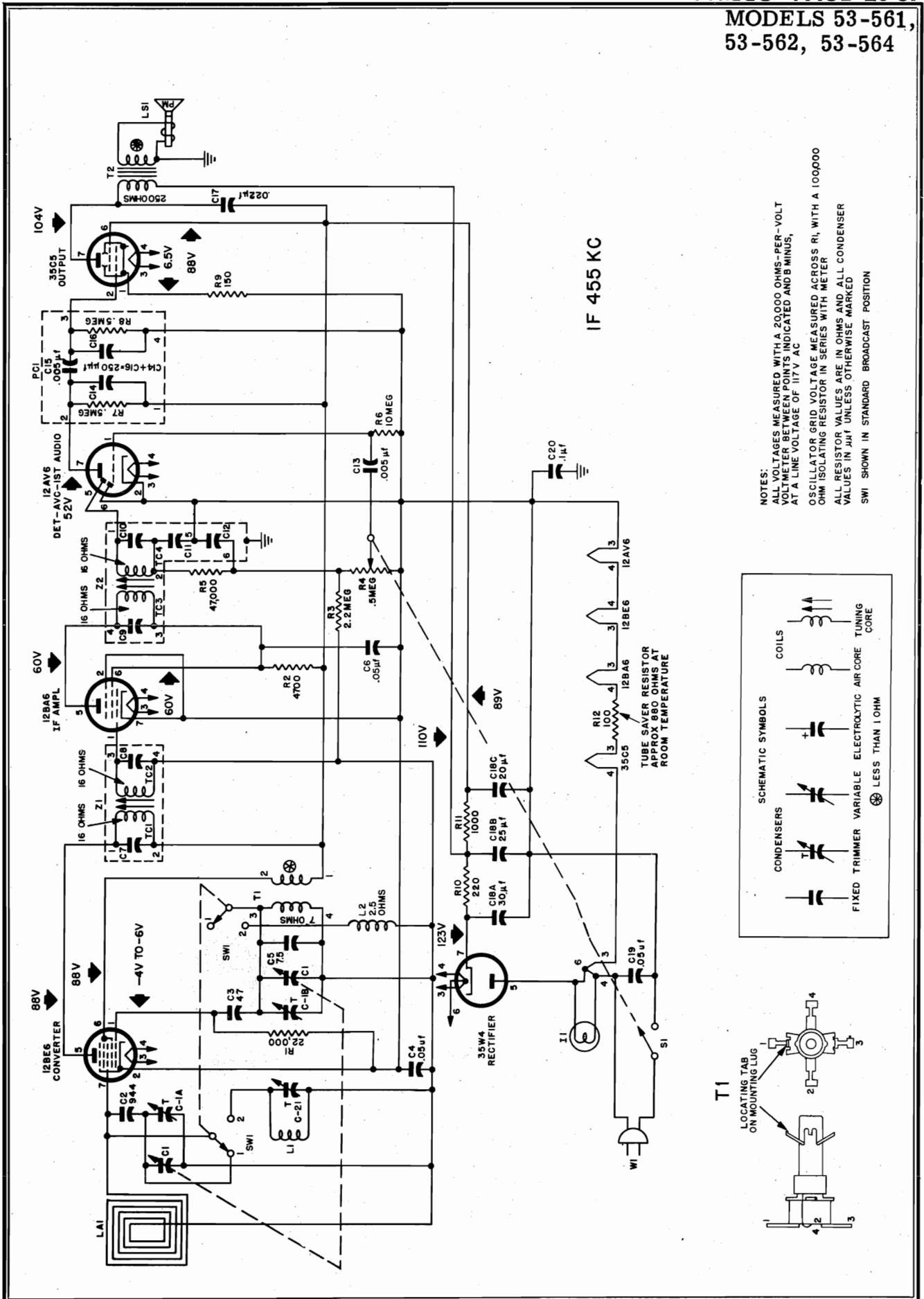

NOTES:
ALL VOLTAGES MEASURED WITH A 20,000 OHMS-PER-VOLT
VOLT-METER BETWEEN POINTS INDICATED AND B MINUS,
AT A LINE VOLTAGE OF 117 V AC
OSCILLATOR GRID VOLTAGE MEASURED ACROSS R1, WITH A 100,000
OHM ISOLATING RESISTOR IN SERIES WITH METER
ALL RESISTOR VALUES ARE IN OHMS AND ALL CONDENSER
VALUES IN μ F UNLESS OTHERWISE MARKED
SWI SHOWN IN STANDARD BROADCAST POSITION

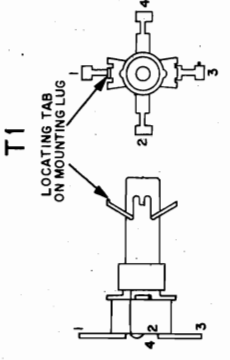
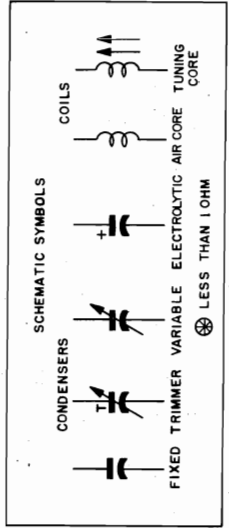

MODELS 53-561,
53-562, 53-564

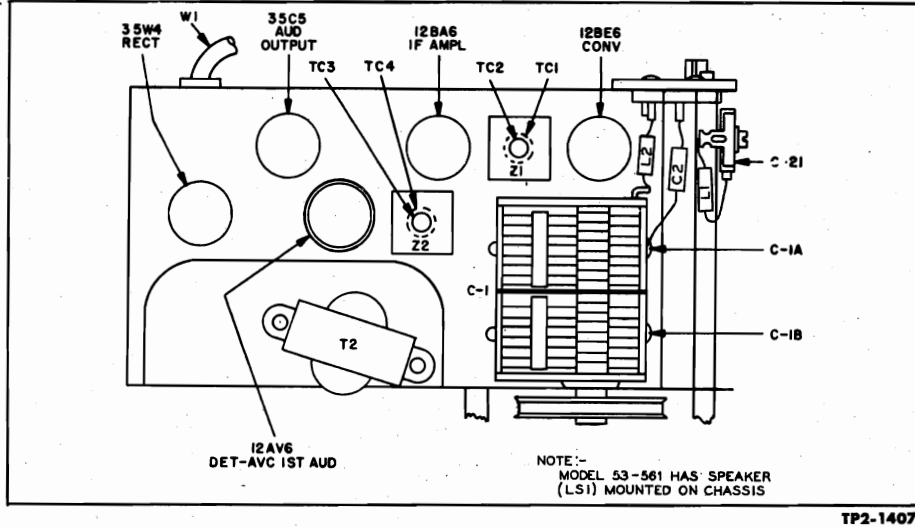

Figure 4. Top View, Showing Trimmer Locations

PARTS LIST

NOTE: Part numbers identified by an asterisk (*) are general replacement items. These numbers may not be identical with those on factory parts. Also, the electrical values of some replacement items may differ from the values indicated in the schematic diagram and parts list. The values substituted in any case are so chosen that the operation will be either unchanged or improved. When ordering replacements, use only the "Service Part No."

Reference Symbol	Description	Service Part No.
C1	Condenser, tuning gang	31-2751-14
C1A	Condenser, aerial trimmer	Part of C1
C1B	Condenser, osc. trimmer	Part of C1
C2	Condenser, aerial series tracker, 944 $\mu\text{f.}$	45-3505-47
C3	Condenser, oscillator grid, 47 $\mu\text{f.}$	30-1230-4
C4	Condenser, a-v-c by-pass, .05 $\mu\text{f.}$	45-3505-28*
C5	Condenser, drift compensation, 7.5 $\mu\text{f.}$	30-1224-83
C6	Condenser, screen by-pass, .05 $\mu\text{f.}$	45-3505-28*
C7	Condenser, i-f tuning	Part of Z1
C8	Condenser, i-f tuning	Part of Z1
C9	Condenser, i-f tuning	Part of Z2
C10	Condenser, i-f tuning	Part of Z2
C11	Condenser, detector filtering	Part of Z2
C12	Condenser, detector filtering	Part of Z2
C13	Condenser, audio coupling, .005 $\mu\text{f.}$	30-1238-1
C14	Condenser, plate by-pass	Part of PC1
C15	Condenser, audio coupling, .005 $\mu\text{f.}$	Part of PC1
C16	Condenser, compensating	Part of PC1
C17	Condenser, tone compensation, .022 $\mu\text{f.}$	45-3505-43*
C18	Condenser, electrolytic, 3-section	30-2575-34
C18A	Condenser, filter, 30 $\mu\text{f.}$, 150v	Part of C18
C18B	Condenser, filter, 25 $\mu\text{f.}$, 150v	Part of C18
C18C	Condenser, filter, 20 $\mu\text{f.}$, 150v	Part of C18
C19	Condenser, line by-pass, .05 $\mu\text{f.}$	45-3505-62*
C20	Condenser, B- to chassis, .1 $\mu\text{f.}$	45-3505-47*
C21	Condenser, trimmer, special service	31-6473-29
I1	Lamp, pilot	34-2068
LA1	Loop, aerial	76-7718
L1	Coil, antenna, special services	32-4561-3
L2	Coil, oscillator shunt	32-4562-2
LS1	Speaker, p-m	36-1627-8
PC1	Printed circuit	30-6001
R1	Resistor, oscillator grid, 22000 ohms	66-3228340*
R2	Resistor, i-f screen dropping, 4700 ohms	66-2748340*
R3	Resistor, a-v-c filter, 2.2 megohms	66-5228340*
R4	Resistor, volume control	33-5566-41
R5	Resistor, diode load, 47,000 ohms	66-3478340*
R6	Resistor, grid return, 10 megohms	66-6108340*
R7	Resistor, plate load, 500,000 ohms	Part of PC1
R8	Resistor, grid return, 500,000 ohms	Part of PC1
R9	Resistor, cathode bias, 150 ohms	66-1158340*
R10	Resistor, B plus filter, 220 ohms	66-1224340*
R11	Resistor, B plus filter, 1000 ohms	66-2108340*
R12	Resistor, tube saver, 100 ohms	33-1343-3
S1	Switch, off-on	Part of R4
SW1	Switch, broadcast-special services	42-1796-2
T1	Transformer, oscillator	32-4453-6
T2	Transformer, output	32-8384*

Reference Symbol	Description	Service Part No.
W1	Line cord	L-2183*
Z1	Transformer, 1st i-f	32-4161A
Z2	Transformer, 2nd i-f	32-4240A

MISCELLANEOUS

Description	Service Part No.
Cabinet	
Model 53-561	
Ivory	10925-1
Colonial green	10925-5
Maroon	10925-3
Light beige	10925-7
Model 53-562	
Maroon	10926-3
Forest green	10926-5
Tangerine	10926-7
Ivory	10926
Model 53-564	
Maroon	10927-1
Back-and-Loop Assembly	
Model 53-561	76-7718
Model 53-562	76-7759
Model 53-564	76-7769
Knob (2)	
Model 53-561	
Ivory cabinet	54-4980-1
Maroon cabinet	
Light beige cabinet	
Colonial green cabinet	
Model 53-562	
Maroon cabinet	54-4773-3
Ivory cabinet	
Forest green cabinet	
Tangerine cabinet	
Model 53-564	
Maroon cabinet	54-4982
Drive Cord, 25-foot spool	45-8750
Pointer, Dial	
Model 53-561	54-4981
Model 53-562	56-9834
Model 53-564	54-4979
Shaft, tuning	56-9807FA11
Socket assembly, pilot lamp	27-6233-6
Socket, 7-pin miniature	27-6265
Socket	27-6265
Spring, retaining	28-8610
Spring	56-2617

SPECIFICATIONS

CABINET MODEL 53-560 Molded plastic
 CIRCUIT Four-tube superheterodyne (plus rectifier)
 FREQUENCY RANGE Standard broadcast, 540 kc.-1620 kc.
 AUDIO OUTPUT 1 watt
 OPERATING VOLTAGE 105-120 volts, a.c. or d.c.
 POWER CONSUMPTION 30 watts
 AERIAL High-impedance loop
 INTERMEDIATE FREQUENCY 455 kc.
 PHILCO TUBES 12BE6 converter, 12BA6 i-f amplifier, 12AV6 det.-
 a.v.c.-1st audio, 35C5 output, 35W4 rectifier

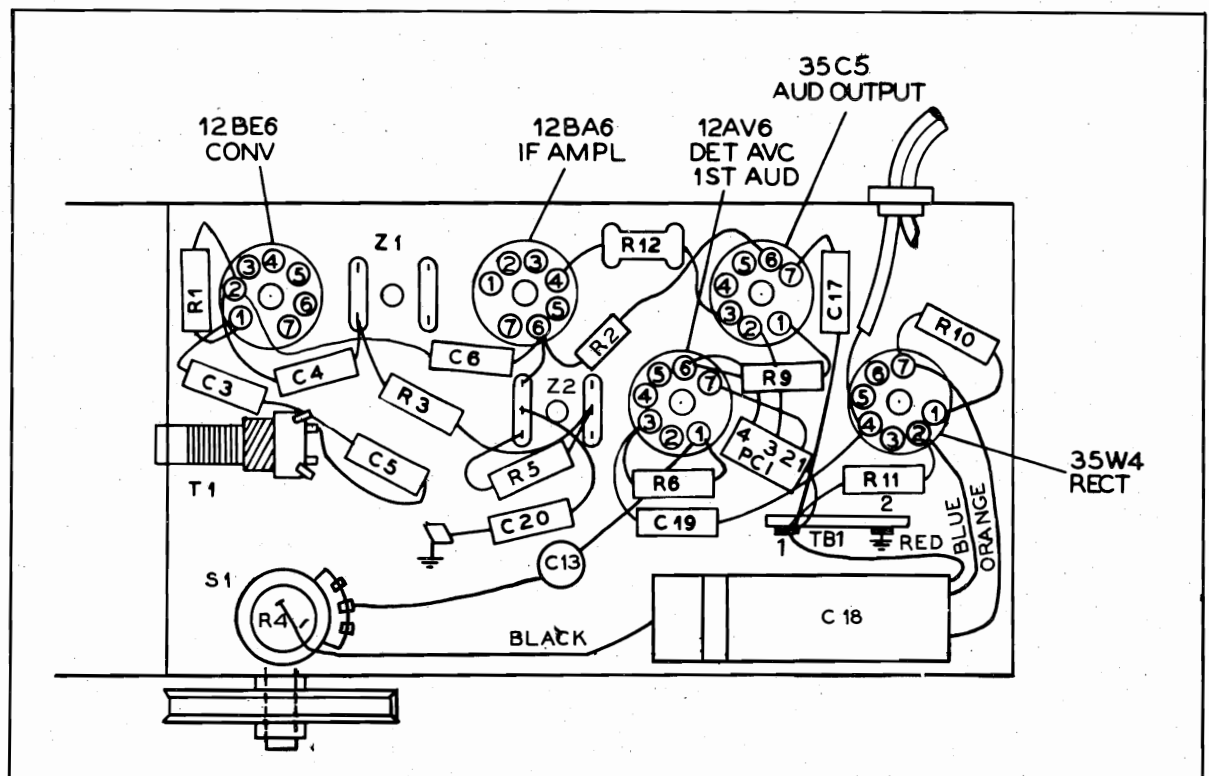

TP2-1397

Figure 1. Base View, Showing Symbolized Chassis

PR-2172

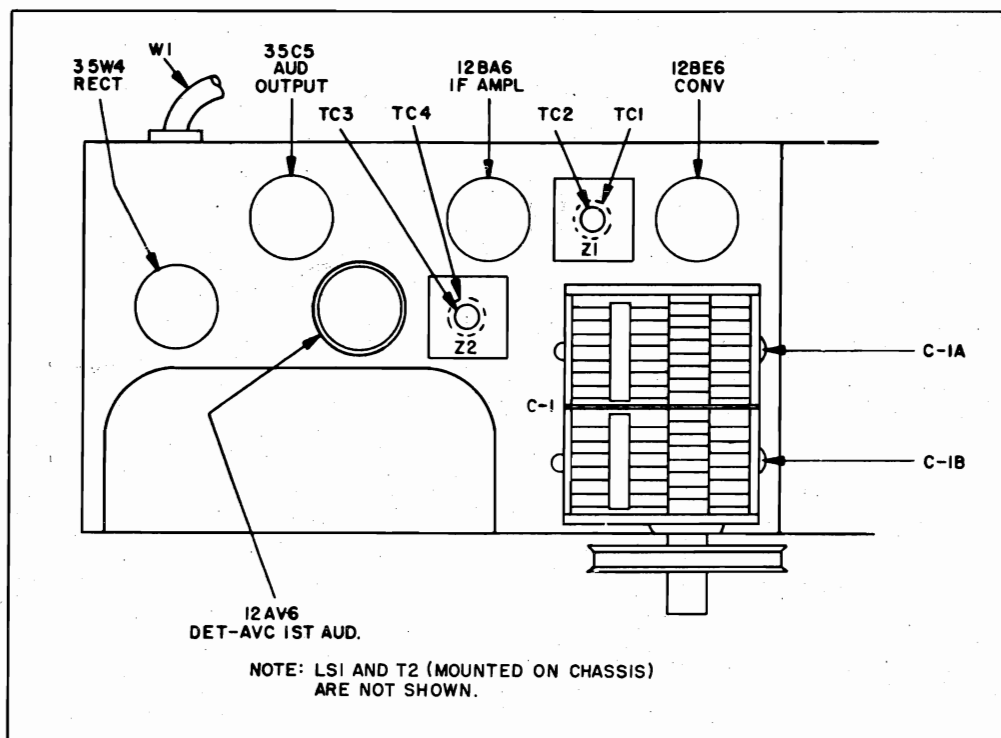

TP2-1396

Figure 2. Top View, Showing Trimmer Locations

ALIGNMENT PROCEDURE

RADIO CONTROLS—Set volume control to maximum. Set tuning control as indicated in chart.

OUTPUT METER—Connect across voice-coil terminals.

SIGNAL GENERATOR—Connect signal generator

and set frequency as indicated in chart. Use modulated output.

OUTPUT LEVEL—During alignment, attenuate signal-generator output to hold output-meter reading below 1.25 volts.

STEP	SIGNAL GENERATOR		RADIO		ADJUST
	CONNECTION TO RADIO	DIAL SETTING	DIAL SETTING	SPECIAL INSTRUCTIONS	
1	Ground lead to B-; output lead through a .1- μ f. condenser to grid (pin 7) of I2BE6.	455 kc.	Tuning gang fully open.	Adjust tuning cores, in order given, for maximum output. (TC1 and TC3 are located at top of transformer.)	TC4—2nd i-f sec. TC3—2nd i-f pri. TC2—1st i-f sec. TC1—1st i-f pri.
2	Radiating loop (see note below).	1620 kc.	*1620 kc.	Adjust trimmer for maximum output.	C1B—osc.
3	Same as step 2.	1500 kc.	1500 kc.	Adjust trimmer for maximum output.	C1A—aerial

RADIATING LOOP: Make up a 6–8 turn, 6-inch-diameter loop from insulated wire, connect to signal-generator leads, and place near radio loop.

***NOTE:** For proper adjustment of the oscillator trimmer, fully open the tuning gang and insert a .006-inch, non-metallic shim between the heel of the rotor and the top of the stator plates. Close the tuning gang sufficiently to hold the shim in place, and then remove the shim without disturbing the gang setting.

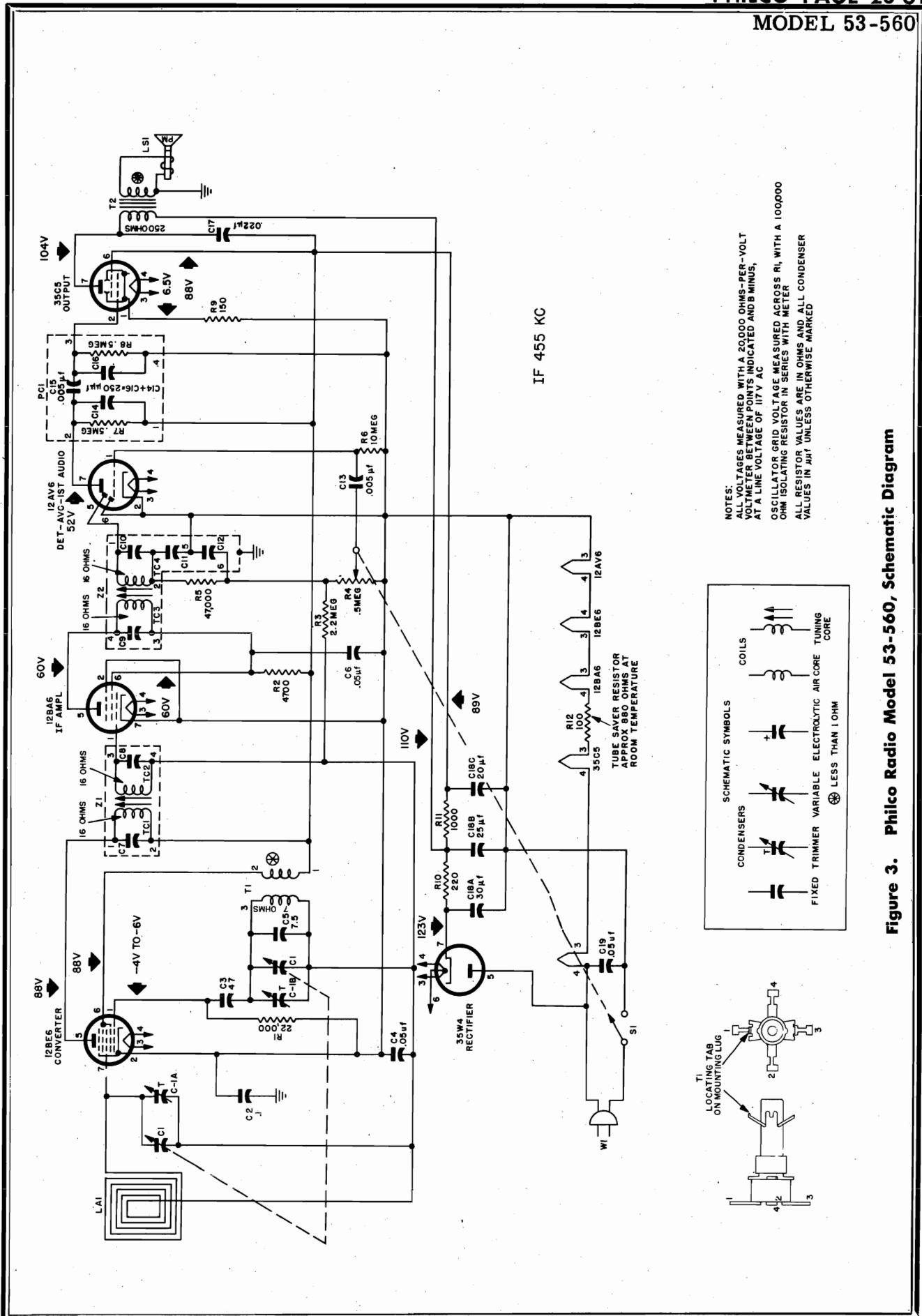
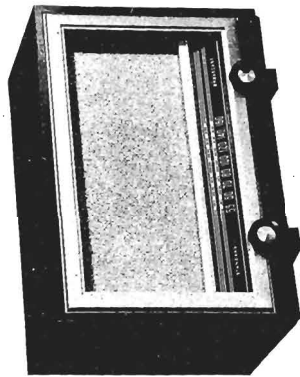

Figure 3. Philco Radio Model 53-560, Schematic Diagram

NOTE: Part numbers identified by an asterisk (*) are general replacement items. These numbers may not be identical with those on factory parts. Also, the electrical values of some replacement items may differ from the values indicated in the schematic diagram and parts list. The values substituted in any case are so chosen that the operation will be either unchanged or improved. When ordering replacements, use only the "Service Part No."

Reference Symbol	Description	Service Part No.	Reference Symbol	Description	Service Part No.
C1	Condenser, tuning gang	31-2751-13	R4	Resistor, volume control, .5 megohms (with off-on switch)	33-5566-41
C1A	Condenser, aerial trimmer	Part of C1	R5	Resistor, diode load, 47,000 ohms, ½ w	66-3478340*
C1B	Condenser, osc. trimmer	Part of C1	R6	Resistor, grid return, 10 megohms, ½ w	66-6108340*
C2	Condenser, leakage, 1 µf.	45-3505-47	R7	Resistor, plate load, 500,000 ohms	Part of PCI
C3	Condenser, oscillator grid, 47 µµf.	30-1230-4	R8	Resistor, grid return, 500,000 ohms	Part of PCI
C4	Condenser, a-v-c by-pass, .05 µf.	45-3505-28*	R9	Resistor, cathode bias, 150 ohms, ½ w	66-1158340*
C5	Condenser, drift compensation, 7.5 µµf.	30-1224-83	R10	Resistor, B plus filter, 220 ohms, 1 w	66-1224340*
C6	Condenser, screen by-pass, .05 µf.	45-3505-28*	R11	Resistor, B plus filter, 1000 ohms, ½ w	66-2108340*
C7	Condenser, i-f tuning	Part of Z1	R12	Resistor, tube saver, 100 ohms	33-1343-3
C8	Condenser, i-f tuning	Part of Z1	S1	Switch, off-on	Part of R4
C9	Condenser, i-f tuning	Part of Z2	T1	Transformer, oscillator	32-4453-6
C10	Condenser, i-f tuning	Part of Z2	T2	Transformer, output	32-8384*
C11	Condenser, detector filtering	Part of Z2	W1	Line cord	L-2183*
C12	Condenser, detector filtering	Part of Z2	Z1	Transformer, 1st i-f	32-4161A
C13	Condenser, audio coupling, .005 µf.	30-1238-1	Z2	Transformer, 2nd i-f	32-4240A
C14	Condenser, plate by-pass	Part of PCI	MISCELLANEOUS		
C15	Condenser, audio coupling, .005 µf.	Part of PCI	Description		Service Part No.
C16	Condenser, plate by-pass	Part of PCI	Cabinet, ebony		10921
C17	Condenser, tone compensation, .022 µf.	45-3505-43*	Cabinet, ivory		10921-2
C18	Condenser, electrolytic, 3-section	30-2573	Cabinet, mahogany		10921-1
C18A	Condenser, filter, 30 µf., 150v	Part of C18	Cabinet back-and-loop assembly		76-7705
C18B	Condenser, filter, 25 µf., 150v	Part of C18	Drive cord, 25-foot spool		45-8750
C18C	Condenser, filter, 20 µf., 150v	Part of C18	Knob, tuning		54-4969
C19	Condenser, line by-pass, .047 µf.	45-3505-62*	Ebony		27-4815-8
LS1	Speaker, p-m	36-1627-8	Ivory		27-4815-10
PCI	Printed circuit	30-6001	Mahogany		54-4118
R1	Resistor, oscillator grid, 22,000 ohms, ½ w	66-3228340*	Socket, 7-pin miniature (5 required)		27-6265*
R2	Resistor, i-f screen droppping, 4,700 ohms, ½ w	66-2748340*			
R3	Resistor, a-v-c filter, 2.2 megohms, ½ w	66-5228340*			



MODEL 52-549

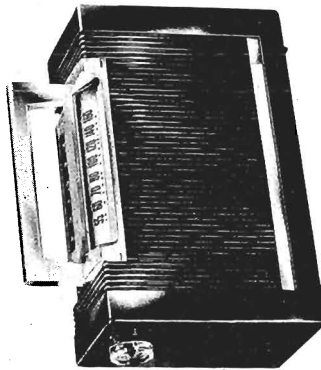

MODEL 52-642

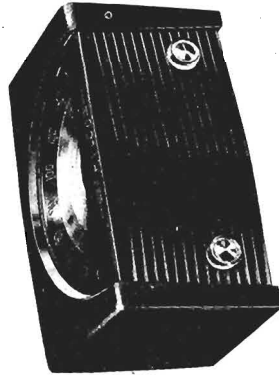

MODEL 52-939

SPECIFICATIONS

MODEL 52-549

CABINET Wood
 CIRCUIT 4-tube superheterodyne
 (plus rectifier)
 FREQUENCY RANGE 540-1630 kc.
 AUDIO OUTPUT 1.2 watts
 OPERATING VOLTAGE 105-125 volts, a.c. or d.c.

POWER CONSUMPTION 30 watts
 AERIAL High-impedance loop;
 connector for external aerial
 INTERMEDIATE FREQUENCY 455 kc.
 PHILCO TUBES (4 plus rectifier) 7A8,
 12BA6, 12AV6, 35L6CT, 35Z5GT

MODEL 52-642

CABINET Plastic, portable
 CIRCUIT 4-tube superheterodyne
 (plus selenium rectifier)
 FREQUENCY RANGE 540-1620 kc.
 AUDIO OUTPUT 150 milliwatts
 A-c or d-c operation 75 milliwatts
 Battery operation 117 volts, a.c. or d.c.;
 OPERATING VOLTAGES 1.5-volt "A" and 67.5-volt "B" battery

POWER CONSUMPTION 11 watts
 A-c or d-c operation 9.5 ma. from 67.5-volt "B" battery
 Battery operation 250 ma. from 1.5-volt "A" battery
 AERIAL Magnecor high-impedance loop;
 provision for connecting external aerial
 INTERMEDIATE FREQUENCY 455 kc.
 PHILCO TUBES (4) 1R5, 1U4, 1U5, and 3V4
 BATTERY TYPE P-67 "B" battery
 TYPE D "A" battery

MODEL 52-939

CABINET Molded plastic
 CIRCUIT 5-tube superheterodyne
 (plus rectifier)
 FREQUENCY RANGE 540-1620 kc.
 AUDIO OUTPUT 1 watt
 OPERATING VOLTAGE 105-120 volts, a.c. or d.c.

POWER CONSUMPTION 30 watts
 AERIAL High-impedance loop;
 provision for connecting external aerial
 INTERMEDIATE FREQUENCY 455 kc.
 PHILCO TUBES (5 plus rectifier) 7B7(2),
 7AB, 14B6, 35L6CT, 35Z5GT

MODELS 52-549,
52-642, 52-939

ALIGNMENT PROCEDURE

The alignment procedures for the receivers covered by this manual are given in the service manuals listed below.

Model 52-549.....	same as.....	Model 52-541,	Pgs. 1-4
Model 52-642.....	same as.....	Model 52-640,	Pgs. 17-20
Model 52-939.....	same as.....	Model 52-940,	Pgs. 25-28

SCHEMATIC DIAGRAMS

The schematic diagrams for the models in this manual are given in the service manuals listed above. Models 52-549 and 52-642 differ from the basic circuit only as described below.

MODEL 52-549 CIRCUIT

The circuit for this set differs from that of Model 52-541 only in the audio section. See figure 1 and Pg 1-4. These changes are as follows, and are in

addition to component part number changes given in the parts list in this service manual.

A condenser, C12, 220 $\mu\text{f.}$, Part No. 62-122001011, is connected between the high side and the center arm of the volume control, R8. Condenser C12 is used for high-frequency compensation.

The tone-compensation condenser, C8, was changed from .05 $\mu\text{f.}$ to .03 $\mu\text{f.}$, Part No. 30-4517.

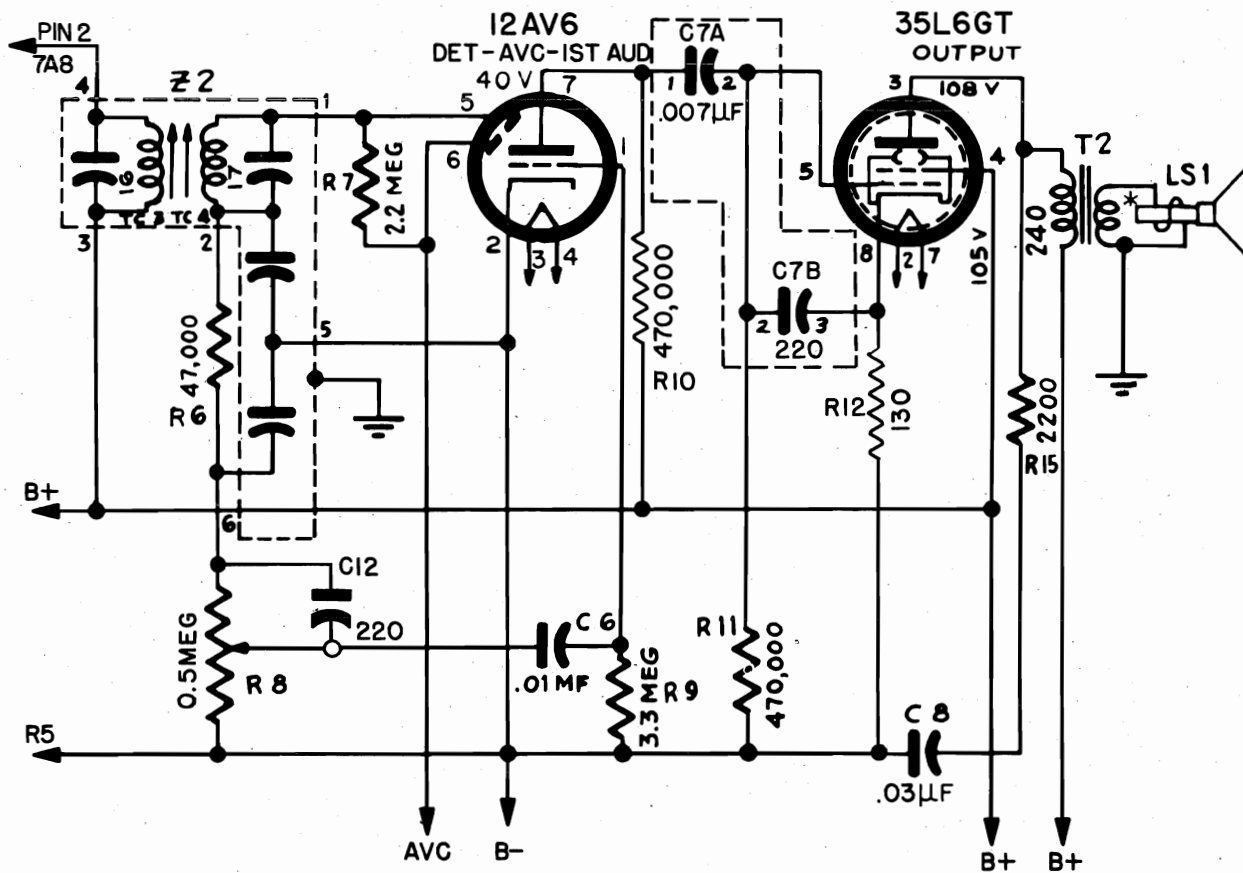

Figure 1. Model 52-549, Second Detector and Audio Amplifier Circuits

TP2-1817

MODELS 52-549,
52-642, 52-939

MODEL 52-642 CIRCUIT

The circuit for this set differs from that of Model 52-640 in that it includes a Private Listening Unit receptacle. See figure 2 and Pg17-20. The Private

Listening Unit receptacle, J3, Part No. 42-1975-2, is wired into the circuit as shown in figure 2. A shunt resistor, R19, Part No. 66-0108340, reduces volume to the correct level for Private Listening. R19, a 10-ohm resistor, is wired from J3 to chassis ground.

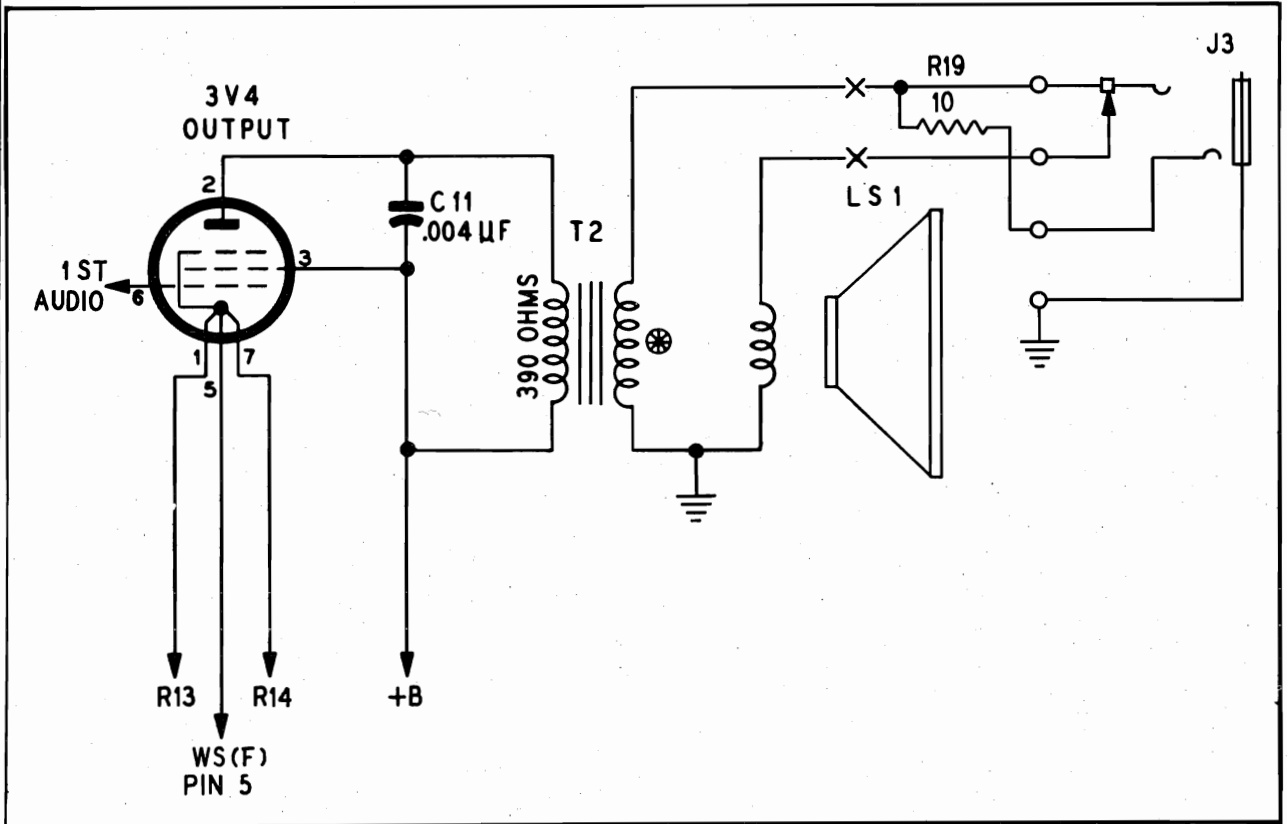

Figure 2. Model 52-642, Output Circuit Showing the Connections for a Private Listening Unit

TP2-2030

Reference Symbol	Description	Service Part No.
IL	Pilot-lamp assembly	76-1179-7
LA1	Loop aerial	32-4052-65
LS1	Speaker, 6-inch, p.m.	36-1641-1
T2	Transformer, output	32-8384-2

**MISCELLANEOUS
MODEL 52-549**

Description	Service Part No.
Cabinet, mahogany	10910
Knob (2)	54-4774-9
Scale	54-5141
Cabinet, light (blond)	10910-1
Knob (2)	54-4774-10
Scale	54-5141-1
Cabinet, ebony	10910-2
Knob (2)	54-4774-18
Scale	54-5141
Back, cabinet (all models)	54-8640
Pointer (all models)	56-8774-2

**MISCELLANEOUS (Cont.)
MODEL 52-642**

Description	Service Part No.
Cabinet	
Teal green	10799-13
Maroon	10799-14
Swedish red	10799-15
Caribbean blue	10799-16
Nile green	10799-17
Arabian sand	10799-18
Ebony	10799-19
Knob (2) (all models)	54-4773
Pointer (all models)	56-7973-1
Scale (all models)	54-5087

MODEL 52-939

Cabinet, ebony	76-7541
Back	318-3289
Knob (2)	54-4718-36
Pointer assembly	76-5341-4
Scale	54-5071-2

SPECIFICATIONS

CABINETMolded plastic
 CIRCUITFive-tube superheterodyne (plus rectifier)
 FREQUENCY RANGE
 Broadcast540 kc. to 1620 kc.
 Special Services1700 kc. to 3400 kc.
 AUDIO OUTPUT1 watt
 OPERATING VOLTAGE105—120 volts, a.c.
 POWER CONSUMPTION30 watts
 ANTENNABuilt-in, high-impedance loop
 INTERMEDIATE FREQUENCY455 kc.
 PHILCO TUBES6BJ6 r-f ampl.; 12BE6 converter;
 6BJ6 i-f ampl.; 6AQ5 detector, a.v.c., 1st
 audio; 35C5 output; 35W4 rectifier

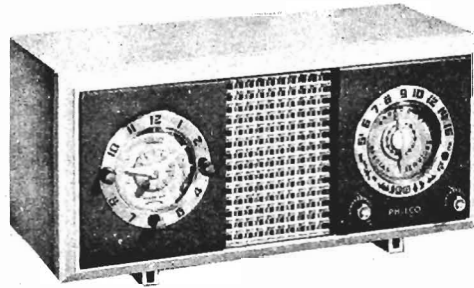

MODEL 53-804

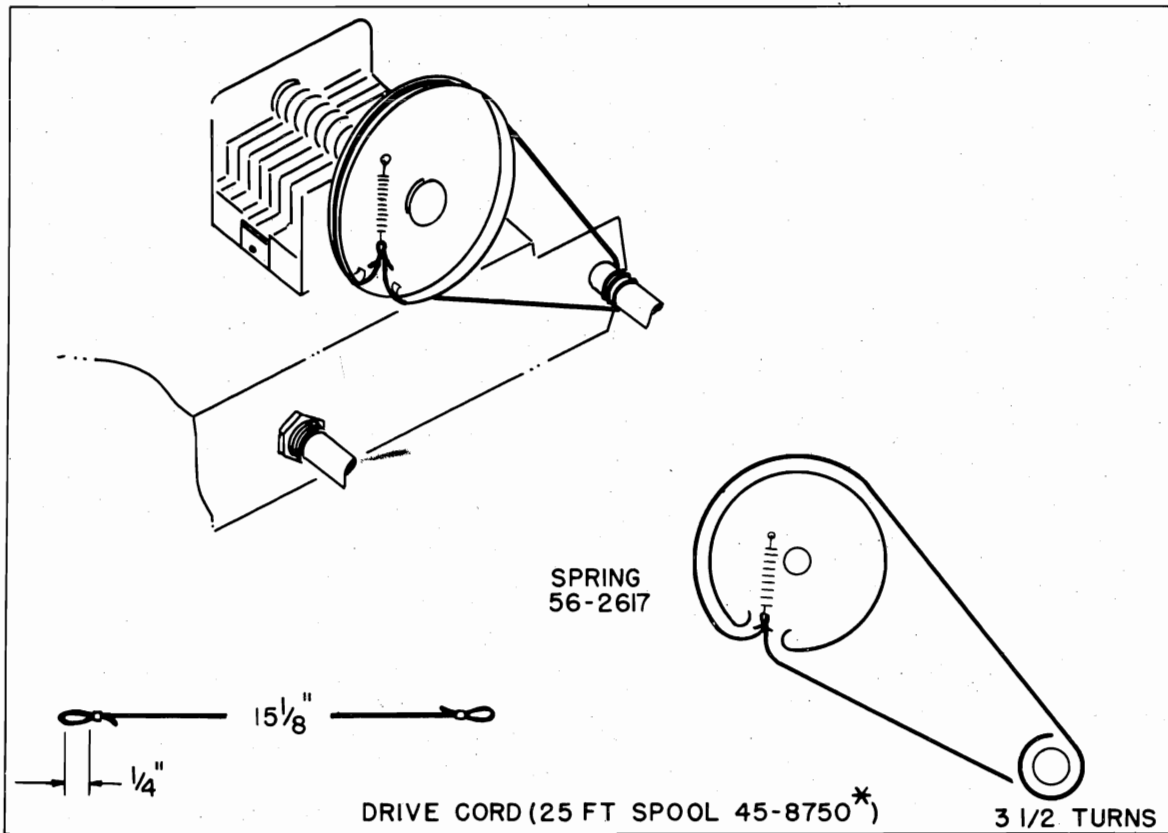

Figure 1. Drive-Cord Installation Details

TP2-1405A

ALIGNMENT PROCEDURE

GENERAL

RADIO CONTROLS—Set volume control for maximum output and tuning control as given in the alignment chart. Set band switch to broadcast position for first 5 steps, and to special services position for steps 6 and 7.

OUTPUT INDICATOR—Connect output indicator (either on oscilloscope or a 1000-ohms-per-volt, a-c voltmeter) across voice-coil terminals.

SIGNAL GENERATOR—Use an AM r-f generator, connected as indicated in the alignment chart.

OUTPUT LEVEL—During alignment, attenuate signal-generator output to maintain output indication below 1 volt.

DIAL POINTER—Before the alignment is started, the dial pointer should be set to coincide with the dial scale mark to the left of "55" when the tuning gang is fully meshed.

ALIGNMENT CHART

STEP	SIGNAL GENERATOR		RADIO		ADJUST
	CONNECTION TO RADIO	DIAL SETTING	DIAL SETTING	SPECIAL INSTRUCTIONS	
1	Ground lead to B—. Output lead through a .01- μ f. condenser to pin 7 (mixer grid) of 12BE6, converter.	455 kc.	Tuning gang fully open.	Adjust, in order given in next column, for maximum output.	TC5—2nd i-f sec. TC4—2nd i-f pri. TC3—1st i-f sec. TC2—1st i-f pri.
2	Radiating loop. See Note 1 below.	1620 kc.	1620 kc. See Note 2 below.	Adjust for maximum output.	C1C—osc. trimmer
3	Same as step 2.	1520 kc.	Tune radio to generator signal.	Adjust for maximum output. (High-frequency adjustment)	C1B—mixer-grid trimmer C1A—r-f trimmer
4	Same as step 2.	580 kc.	Same as step 3.	Adjust for maximum output. (Low-frequency adjustment)	TC1—r-f transformer
5	Repeat steps 3 and 4 until no further improvement is obtained.				
6	Same as step 2.	3200 kc.	Same as step 3.	Adjust for maximum output.	C5—special-services mixer-grid trimmer C2—special-services r-f trimmer
7	Same as step 2.	1800 kc.	Same as step 3.	Adjust for maximum output.	C3—special-services r-f padder

NOTE 1: Make up a 6-8 turn, 6-inch-diameter loop from insulated wire; connect to signal-generator leads and place near radio loop antenna. The loop antenna must be connected to the radio.

NOTE 2: To set the tuning gang to 1620 kc., place a piece of 6-mil flat shim stock beneath the heel of the rotor, and turn the rotor until it holds the shim firmly in place. Then remove the shim.

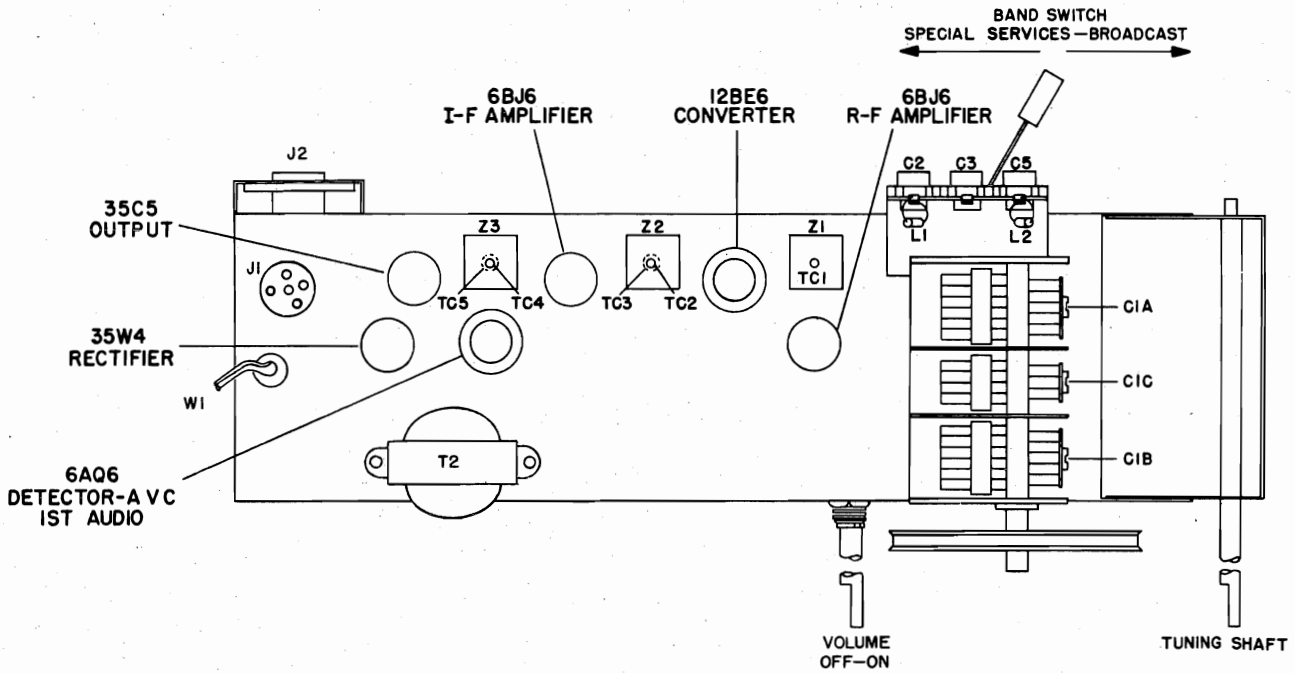

Figure 2. Top View, Showing Tuning Adjustments

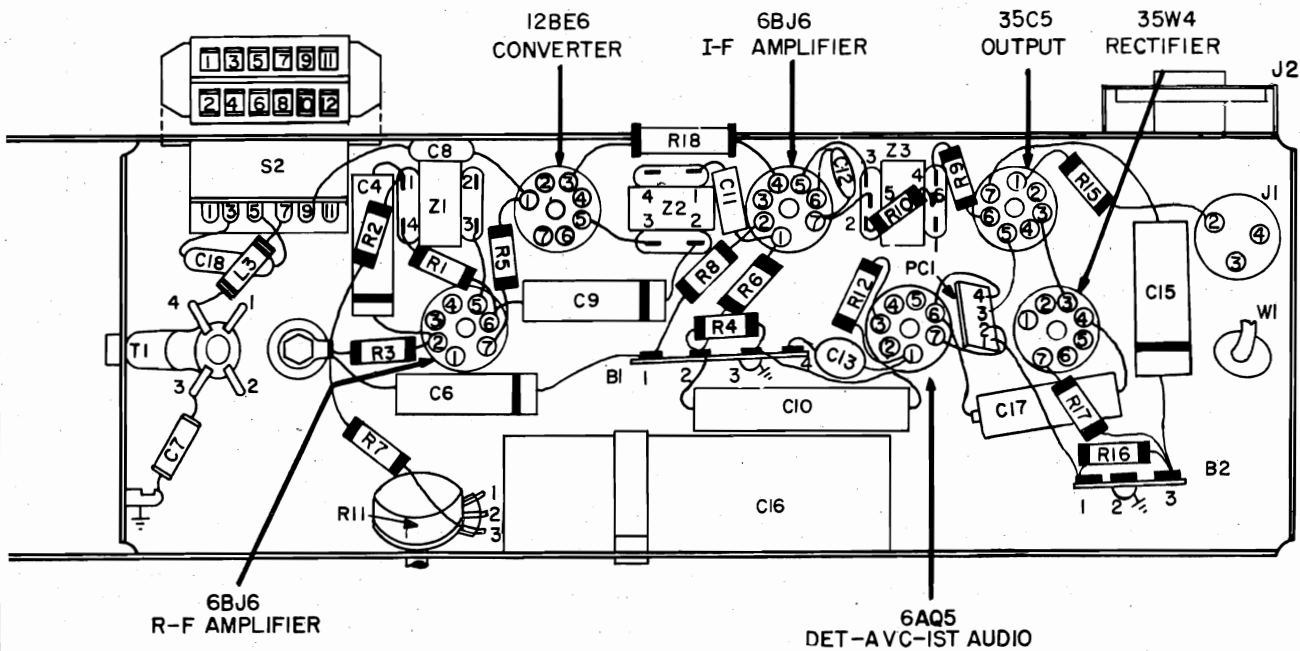
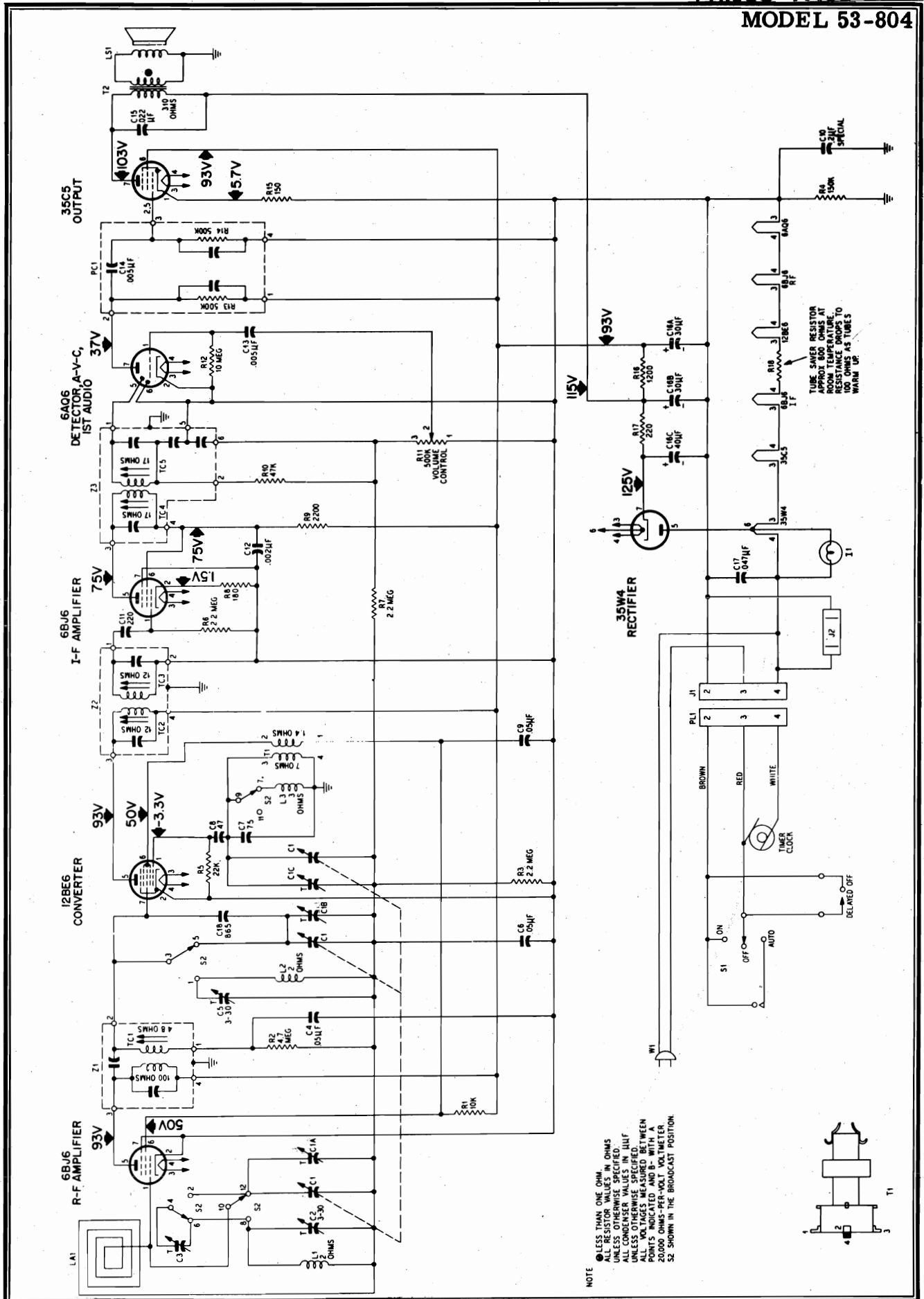
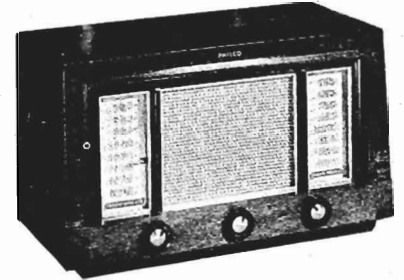

Figure 3. Base View, Showing Parts Placement



SPECIFICATIONS

CABINET.....	Wood table model
CIRCUIT.....	Six-tube superheterodyne plus selenium rectifier
FREQUENCY RANGES	
Broadcast.....	540—1620 kc.
FM.....	88—108 mc.
AUDIO OUTPUT.....	.1 watt
OPERATING VOLTAGE.....	105—125 volts, a.c./d.c.
POWER CONSUMPTION.....	45 watts
ANTENNA.....	Built-in pancake loop for AM; line cord for FM
INTERMEDIATE FREQUENCY	
AM.....	455 kc.
FM.....	9.1 mc.
PHILCO TUBES (6).....	12BA6 r-f ampl., 12AT7 converter, 12BA6 1st i-f ampl., 12AU6 2nd i-f ampl., 19V8 def.-a.v.c.-1st audio, 35C5 output



MODEL 53-958

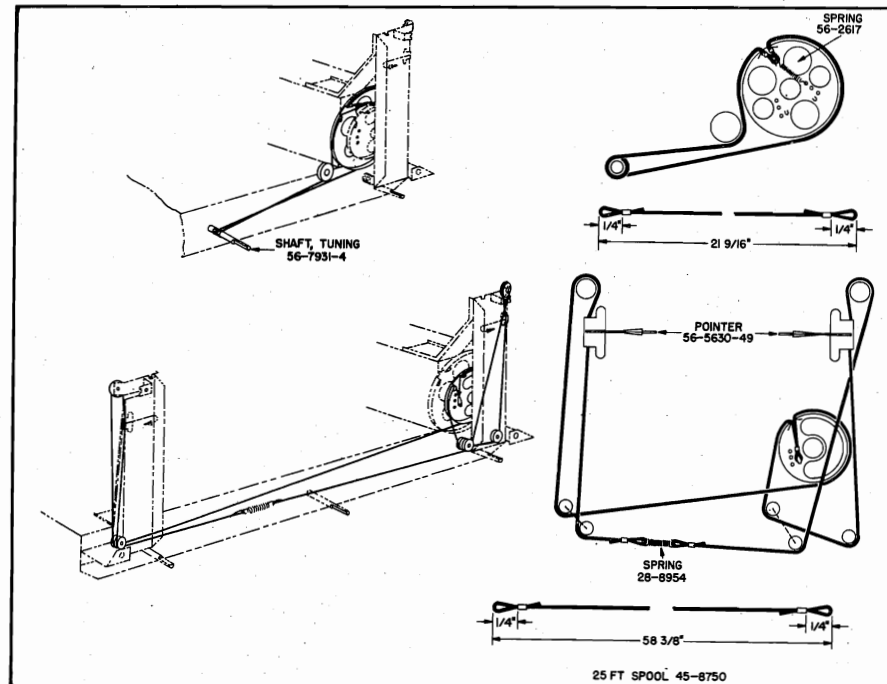

TP2-2284

Figure 1. Drive-Cord Installation Details

MODEL 53-958

AM ALIGNMENT PROCEDURE

GENERAL—Before starting the alignment, allow the radio and the signal generator to warm up for fifteen minutes. Make the alignment with the loop antenna connected to the radio. The AM alignment should be made before the FM alignment is made.

RADIO CONTROLS—Set the volume control to maximum. Set the band switch for broadcast reception. Set the tuning control as indicated in the AM alignment chart.

OUTPUT INDICATOR—Connect the output indicator (an oscilloscope or a 1,000-ohms-per-volt voltmeter) across the voice-coil terminals.

SIGNAL GENERATOR—Use an AM r-f signal generator with modulated output. Connect the generator to the radio, and

set the frequency as indicated in the AM alignment chart.

OUTPUT LEVEL—During the alignment, the signal generator output should be attenuated to hold the output indication below 1 volt.

DIAL POINTER—Before the alignment is started, the dial pointer should be set to coincide with the index mark on the dial pointer rail assembly when the tuning gang is completely closed. See figure 3. (The pointer rail is the metal assembly upon which the pointer rides.)

CAUTION—One side of the a-c line is connected directly to the chassis. Therefore, an isolation transformer should be used when working with this chassis, to prevent injury to personnel or damage to test equipment.

AM ALIGNMENT CHART

STEP	SIGNAL GENERATOR		RADIO		
	CONNECTION TO RADIO	DIAL SETTING	DIAL SETTING	SPECIAL INSTRUCTIONS	ADJUST
1	Ground lead to chassis. Output lead through a .1- μ f. condenser to pin 7 (grid) of 12AT7.	455 kc. (modulated)	Set tuning gang so that dial pointer coincides with the 1630-kc. mark. See figure 3.	Adjust for maximum output, in order given in next column.	TC10—2nd AM i-f sec. TC9—2nd AM i-f pri. TC4—1st AM i-f sec. TC3—1st AM i-f pri.
2	Radiating loop. See note below.	1630 kc. (modulated)	Same as step 1.	Adjust for maximum output.	C1C—osc. trimmer
3	Same as step 2.	1520 kc. (modulated)	Set tuning gang so that dial pointer coincides with 1520-kc. mark. See figure 3.	Adjust for maximum output, in order given in next column.	C1B—r-f trimmer C1A—antenna trimmer (high-frequency adjustment)
4	Same as step 2.	580 kc. (modulated)	Set tuning gang so that dial pointer coincides with 580-kc. mark. See figure 3.	Adjust for maximum output. Rock tuning gang while making this adjustment.	TC12—r-f transformer (low-frequency adjustment)
5	Repeat steps 3 and 4 until no further improvement is obtained.				

NOTE: Make up a six-to-eight turn, 6-inch-diameter loop from insulated wire; connect to generator terminals, and place near radio loop antenna. The radio loop antenna must be connected to the radio.

FM ALIGNMENT PROCEDURE

(Using FM Test Equipment)

GENERAL—Before starting the alignment procedure, allow the radio and the test equipment to warm up for fifteen minutes. The AM alignment should be made before the FM alignment is made.

RADIO CONTROLS—Set the volume control to maximum. Set the band switch for FM reception. Set the tuning controls as indicated in the FM alignment chart.

OUTPUT INDICATOR—The first two steps must be performed with the use of an oscilloscope. Connect the ground leads to the radio chassis. Connect the vertical input to the FM test jack, J2, and the horizontal input to the horizontal sweep output of the sweep signal generator. The remaining steps should be performed with the output indicator connected across the voice-coil terminals (either an oscilloscope or a 1000-ohms-per-volt voltmeter).

SWEEP GENERATOR—Use an FM sweep signal generator. Connect the generator to the radio as indicated in the FM alignment chart. Set the frequency and sweep width as indicated in the chart.

DIAL POINTER—Before the alignment is started, the dial pointer should be set to coincide with the index mark on the dial pointer rail assembly when the tuning gang is fully closed. See figure 3.

CAUTION—One side of the a-c line is connected directly to the chassis. Therefore, an isolation transformer should be used when working with the chassis, to prevent injury to personnel or damage to test equipment.

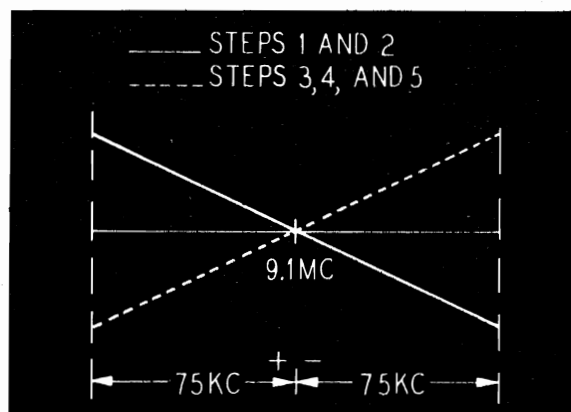

TPI-2111

Figure 2. Characteristic Curve of FM Detector

FM ALIGNMENT CHART

STEP	SIGNAL GENERATOR		RADIO		
	CONNECTION TO RADIO	DIAL SETTING	DIAL SETTING	SPECIAL INSTRUCTIONS	ADJUST
1	Connect ground lead to chassis. Connect output lead through a .01- μ f. condenser to control grid (pin 1) of 12AU6 2nd i-f amplifier (test point A). See figure 5.	9.1 mc. (75-kc. deviation)	88 mc. (gang fully meshed).	Adjust TC8 for balance and TC7 for maximum indication (maximum slope) on scope as shown in figure 2.	TC8—detector sec. TC7—detector pri.
2	Connect ground lead to chassis. Connect output lead through a .01- μ f. condenser to FM tuning gang stator lug, junction of C1 and pin 4 of L2 (test point B). See figure 5.	Same as step 1.	Same as step 1.	Adjust in order given in next column, for maximum indication (maximum slope) on scope as shown in figure 2.	TC6—FM 2nd i-f sec. TC5—FM 2nd i-f pri. TC2—FM 1st i-f sec. TC1—FM 1st i-f pri.
3	Connect output lead to lug 2 of TB1, and ground side of generator to lug 1 of TB1 (test point C). See figure 4. See note 1 below.	108.5 mc.	Set tuning gang so that dial pointer coincides with 108.5-mc. mark. See figure 3.	Adjust for maximum indication on output indicator.	C18—FM osc. trimmer
4	Same as step 3.	92 mc.	Set tuning gang so that dial pointer coincides with 92-mc. mark. See figure 3.	Adjust for maximum indication on output indicator. See note 2 below.	L5—FM osc. coil
5	Same as step 3.	105 mc.	Set tuning gang so that dial pointer coincides with 105-mc. mark. See figure 3.	Adjust for maximum indication on output indicator. Rock tuning gang while making this adjustment.	C1D—FM mixer grid (high-frequency adjustment)
6	Same as step 3.	Same as step 5.	Same as step 5.	Adjust for maximum indication on output indicator.	C4—FM r-f grid (high-frequency adjustment)
7	Same as step 3.	92 mc.	Same as step 4.	Adjust for maximum indication on output indicator. See note 3 below.	L2—FM mixer grid (low-frequency adjustment)
8	Same as step 3.	Same as step 7.	Same as step 4.	Adjust for maximum indication on output indicator.	TC11—FM r-f grid (low-frequency adjustment)

NOTE 1: For accurate results, the signal-generator output impedance must be 300 ohms to match the input impedance of TB1. If the signal-generator output impedance is less than 300 ohms, a resistor of the proper value should be used in series with the output lead to make the impedance correct. For example, if the output impedance is 150 ohms, place a 150-ohm resistor in series with the output lead.

NOTE 2: With the conditions given in step 4 (step 6 of alternate procedure), if the oscillator is not tuned for maximum output, it may be necessary to compress or spread the coil turns to give maximum output. (Do not disturb the setting of the tuning gang while making any necessary adjustment.) After the coil is adjusted, repeat steps 3 and 4 (steps 5 and 6 of alternate procedure) until no further improvement is obtained. Then proceed to the next step.

NOTE 3: With the conditions given in step 7 (step 8 of alternate procedure), if the mixer-grid circuit is not tuned for maximum output, it may be necessary to compress or spread the coil turns to give maximum output. (Do not disturb the setting of the tuning gang while making any necessary adjustment.) After the coil is adjusted, repeat steps 5 through 7 (steps 7 and 8 of alternate procedure) until no further improvement is obtained. Then proceed to the next step.

MODEL 53-958

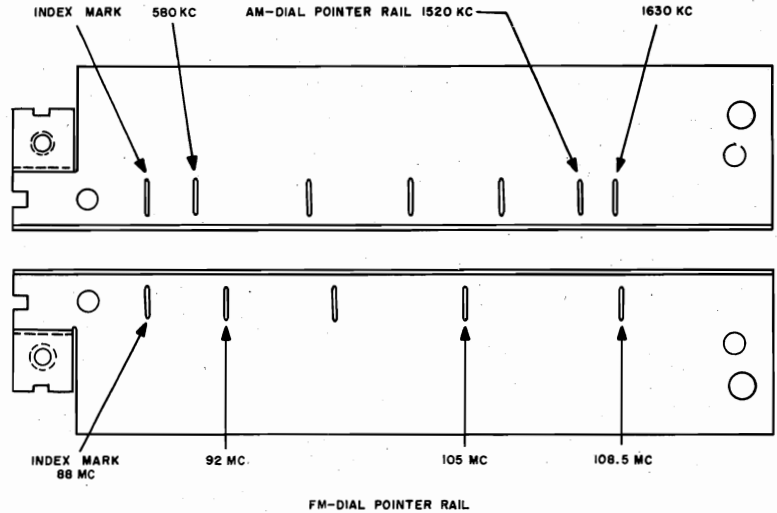

Figure 3. AM and FM Pointer Rails, Showing Alignment Marks

TP2-2602

ALTERNATE FM ALIGNMENT PROCEDURE

This alternate procedure is designed to be used where only AM test equipment is available.

GENERAL—Before starting the alignment procedure, allow the radio and signal generator to warm up for fifteen minutes. The AM alignment should be made before the FM alignment is made.

RADIO CONTROLS—Set the volume control to maximum. Set the band switch for FM reception. Set the tuning control as indicated in the chart.

OUTPUT INDICATOR—Use a 20,000-ohms-per-volt voltmeter.*

SIGNAL GENERATOR—Use an AM r-f signal generator. Connect the generator to the radio, and set the frequency as indicated in the chart.

DIAL POINTER—Before the alignment is started, the dial pointer should be set to coincide with the index mark on the dial pointer rail assembly when the tuning gang is fully closed. See figure 3.

CAUTION—Refer to the CAUTION given in the regular FM alignment procedure.

* In order to perform this alignment it is necessary to place two 100,000-ohm resistors in series between the junction of R17 and C27 (pin 7 of 19V8) and ground. The output meter must be placed between the junction of these two resistors and the FM test jack, J2, for the first step of the alignment, and between the junction of these two resistors and ground for the remaining steps of the alignment with the negative meter lead at the junction of the two resistors. For the first step of the alignment, the meter needle should be set off zero to the first major scale mark by adjusting the meter zero adjust knob. After the first step has been completed, the needle can be set back to the zero mark. The purpose of this adjustment is to enable the serviceman to see a negative indication on the meter.

The output indication for all steps except the first one should be between 5 and 10 volts.

The two series resistors should be as nearly equal in value as possible (at least within 5% of each other).

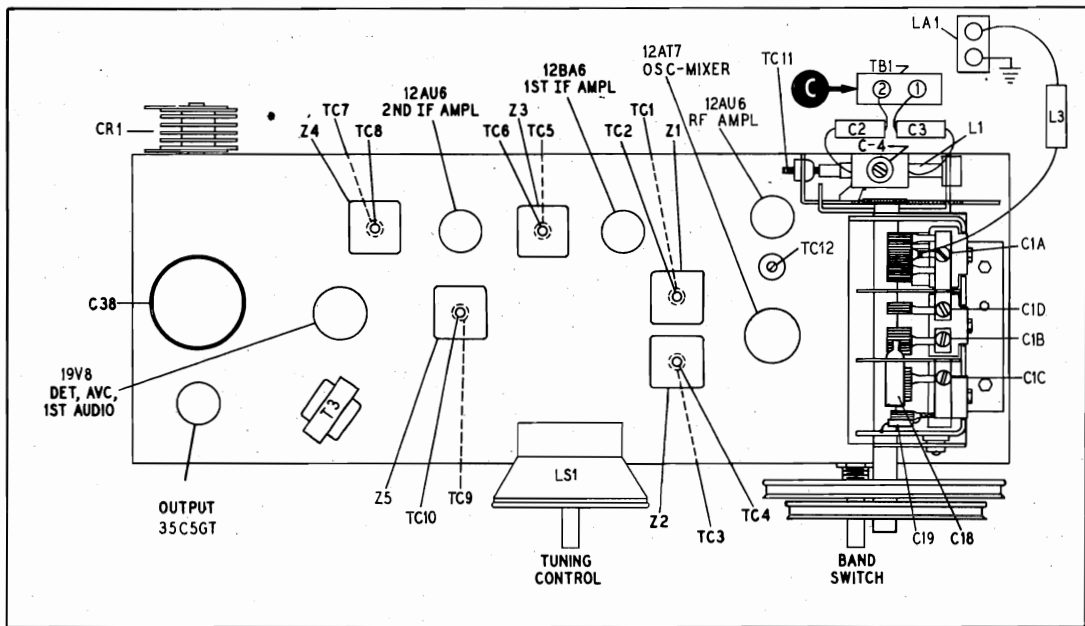

Figure 4. Top View, Showing Trimmer Locations

TP2-2286

ALTERNATE FM ALIGNMENT CHART

STEP	SIGNAL GENERATOR		RADIO		
	CONNECTION TO RADIO	DIAL SETTING	DIAL SETTING	SPECIAL INSTRUCTIONS	ADJUST
1	Connect ground lead to chassis. Connect output lead through a .01- μ f. condenser to pin 1 (grid) of 12AU6 2nd i-f amplifier (test point A). See figure 5.	9.1 mc. (modulated)	88 mc. (gang fully meshed)	Adjust for balance (zero indication on meter).	TC8—FM det. sec.
2	Same as step 1.	Same as step 1.	Same as step 1.	Adjust for maximum output.	TC7—FM det. pri.
3	Connect ground lead to chassis. Connect output lead through a .01- μ f. condenser to pin 1 (grid) of 12BA6 1st i-f amplifier (test point D). See figure 5.	Same as step 1.	Same as step 1.	Adjust in order given in next column, for maximum output.	TC6—2nd FM i-f sec. TC5—2nd FM i-f pri.
4	Connect ground lead to chassis. Connect output lead through a .01- μ f. condenser to junction of C1 and pin 4 of L2 (test point B). See figure 5.	Same as step 1.	Same as step 1.	Adjust in order given in next column for maximum output.	TC2—1st FM i-f sec. TC1—1st FM i-f pri.
5	Connect ground lead to pin 1 of TB1. Connect output lead to pin 2 of TB1 (test point C). See figure 4. See note 1 of regular FM alignment procedure.	108.5 mc.	Set tuning gang so that dial pointer coincides with 108.5-mc. mark. See figure 3.	Adjust for maximum output.	C18—osc. trimmer
6	Same as step 5.	92 mc.	Set tuning gang so that dial pointer coincides with 92-mc. mark. See figure 3.	Adjust for maximum output. See note 2 of regular FM alignment procedure.	L5—FM osc. coil
7	Same as step 5.	105 mc.	Set tuning gang so that dial pointer coincides with 105-mc. mark. See figure 3.	Adjust in order given in next column, for maximum output.	C1D—FM mixer grid C4—FM r-f grid (high-frequency adjustments)
8	Same as step 5.	92 mc.	Same as step 6.	Adjust for maximum output. See note 3 of regular FM alignment procedure.	L2—FM mixer grid (low-frequency adjustment)
9	Same as step 5.	Same as step 6.	Same as step 6.	Adjust for maximum output.	TC11—FM r-f grid (low-frequency adjustment)

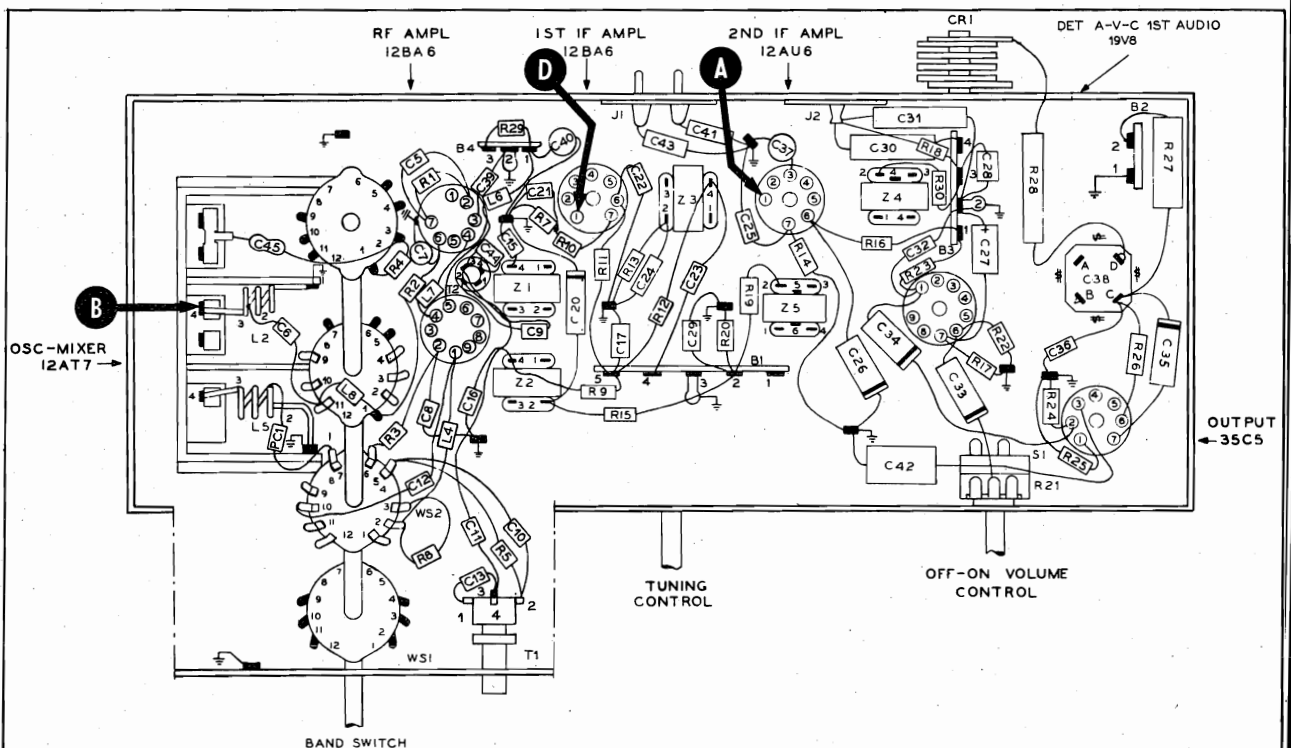
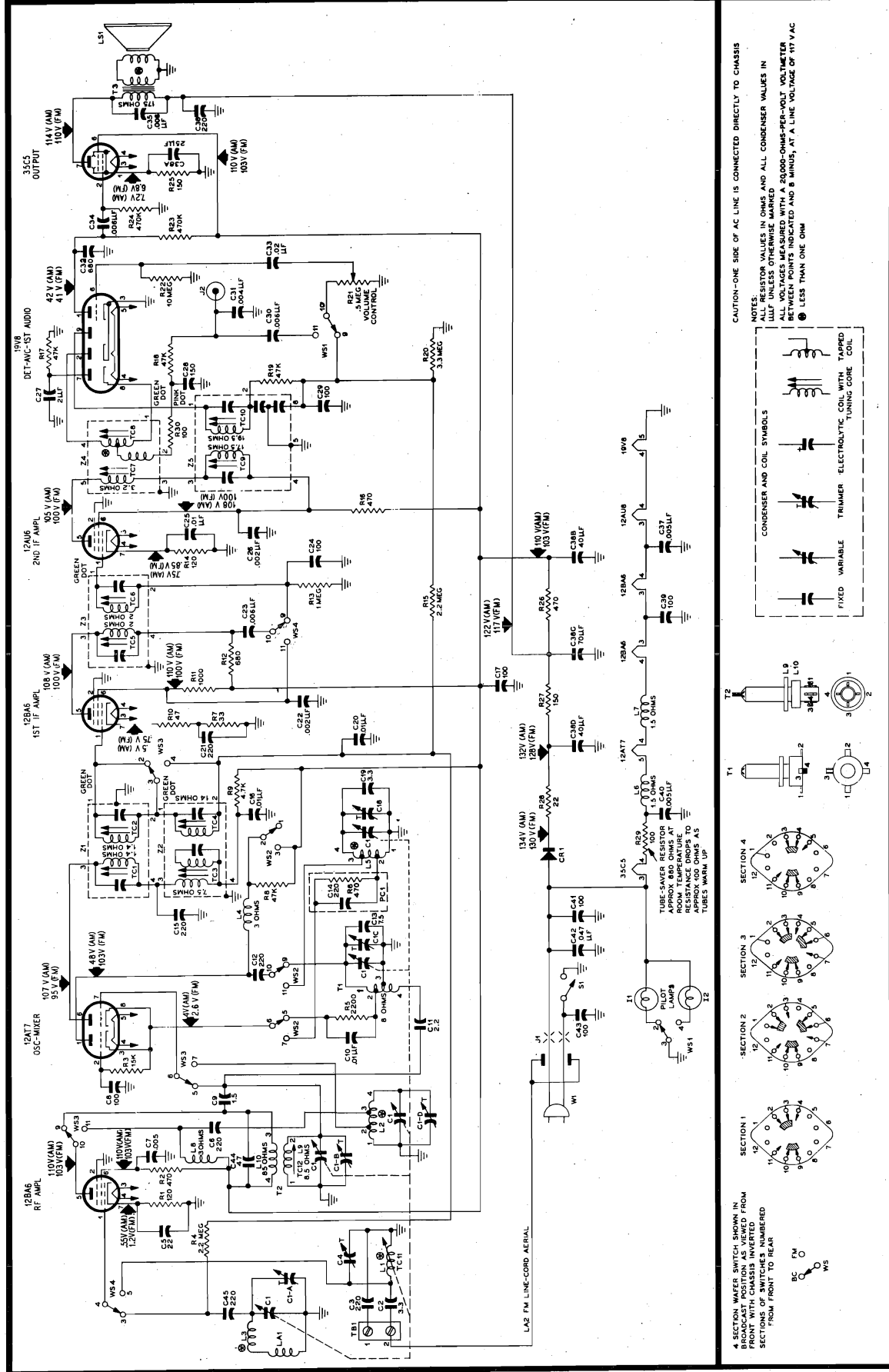

Figure 5. Base View, Showing Parts Placement

TP2-2285



CAUTION—ONE SIDE OF AC LINE IS CONNECTED DIRECTLY TO CHASSIS

NOTES:
 ALL RESISTOR VALUES IN OHMS AND ALL CONDENSER VALUES IN μLF UNLESS OTHERWISE MARKED
 ALL VOLTAGES MEASURED WITH A 20,000-OHMS-PER-VOLT VOLTMETER BETWEEN POINTS INDICATED AND 8 MINUS, AT A LINE VOLTAGE OF 117 V AC
 Ⓢ LESS THAN ONE OHM

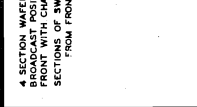
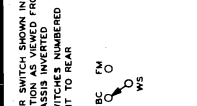
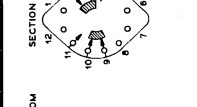
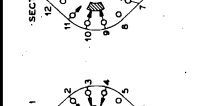
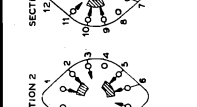
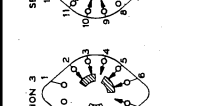
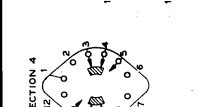
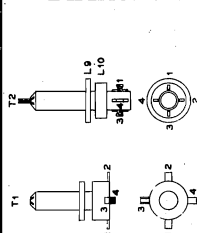
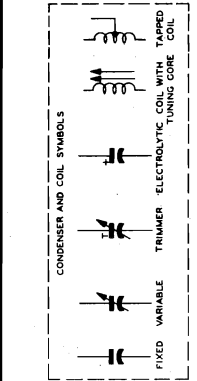

4 SECTION WAFER SWITCH SHOWN IN BROADCAST POSITION AS VIEWED FROM FRONT TO REAR

SECTIONS OF SWITCHES NUMBERED FROM FRONT TO REAR

BC FM

Figure 6. Philco Radio Model 53-958, Schematic Diagram

TP2-2287

PARTS LIST

NOTE: Part numbers identified by an asterisk (*) are general replacement items. These numbers may not be identical with those on factory parts; also, the electrical values of some replacement items may differ from the values indicated in the schematic diagram and parts list. The values substituted in any case are so chosen that the operation of the radio will be either unchanged or improved. When ordering replacements, use only the "Service Part No."

Reference Symbol	Description	Service Part No.	Reference Symbol	Description	Service Part No.
C1	Condenser, tuning gang, 5-section	31-2762-2		100 $\mu\text{f.}$	62-110001021*
C1A	Condenser, trimmer, BC antenna	Part of C1	C25	Condenser, cathode by-pass, .01 $\mu\text{f.}$	30-4650-58*
C1B	Condenser, trimmer, BC r-f	Part of C1	C26	Condenser, screen by-pass, .002 $\mu\text{f.}$	30-4650-54*
C1C	Condenser, trimmer, BC oscillator	Part of C1	C27	Condenser, diode load filter, 2 $\mu\text{f.}$, 50v	30-2417-7
C1D	Condenser, trimmer, FM r-f	Part of C1	C28	Condenser, i-f by-pass, 150 $\mu\text{f.}$	62-115001001*
C2	Condenser, antenna isolating, 3.3 $\mu\text{f.}$	30-1224-49	C29	Condenser, i-f by-pass, 100 $\mu\text{f.}$	62-110001021*
C3	Condenser, antenna isolating, 220 $\mu\text{f.}$	62-122001001*	C30	Condenser, d-c blocking, .006 $\mu\text{f.}$	30-4650-57*
C4	Condenser, FM antenna trimmer	45-3034	C31	Condenser, de-emphasis, .004 $\mu\text{f.}$	30-4650-56*
C5	Condenser, cathode by-pass, 22 $\mu\text{f.}$	62-022009001	C32	Condenser, plate by-pass, 680 $\mu\text{f.}$	62-168001001*
C6	Condenser, d-c blocking, 220 $\mu\text{f.}$	62-122001001*	C33	Condenser, audio coupling, .02 $\mu\text{f.}$	30-4650-60*
C7	Condenser, screen by-pass, .005 $\mu\text{f.}$	30-1238-1*	C34	Condenser, d-c blocking, .006 $\mu\text{f.}$	30-4650-57*
C8	Condenser, oscillator grid, 100 $\mu\text{f.}$	62-110001021*	C35	Condenser, tone compensation, .006 $\mu\text{f.}$	30-4650-57*
C9	Condenser, neutralizing, 1.5 $\mu\text{f.}$	30-1221-7	C36	Condenser, plate decoupling, 220 $\mu\text{f.}$	62-122001001*
C10	Condenser, cathode by-pass, .01 $\mu\text{f.}$	30-4650-58*	C37	Condenser, filament by-pass, .005 $\mu\text{f.}$	30-1238-1*
C11	Condenser, neutralizing, 2.2 $\mu\text{f.}$	30-1221-4	C38	Condenser, electrolytic, 4-section	30-2570-46
C12	Condenser, d-c blocking, 220 $\mu\text{f.}$	30-1224-65	C38A	Condenser, cathode by-pass, 25 $\mu\text{f.}$, 25v	Part of C38
C13	Condenser, fixed trimmer, 7.5 $\mu\text{f.}$	30-1224-65	C38B	Condenser, filter, 40 $\mu\text{f.}$, 150v	Part of C38
C14	Condenser, cathode by-pass, 220 $\mu\text{f.}$	Part of PC1	C38C	Condenser, filter, 70 $\mu\text{f.}$, 150v	Part of C38
C15	Condenser, r-f by-pass, 220 $\mu\text{f.}$	62-122001001*	C38D	Condenser, filter, 40 $\mu\text{f.}$, 150v	Part of C38
C16	Condenser, plate decoupling, .01 $\mu\text{f.}$	30-4650-58*	C39	Condenser, filament by-pass, 100 $\mu\text{f.}$	62-110001021*
C17	Condenser, r-f by-pass, 100 $\mu\text{f.}$	62-110009001*	C40	Condenser, filament by-pass, .005 $\mu\text{f.}$	30-1238-1*
C18	Condenser, trimmer, FM oscillator	31-6511-10	C41	Condenser, line by-pass, 100 $\mu\text{f.}$	62-110001021*
C19	Condenser, fixed trimmer, 3.3 $\mu\text{f.}$	30-1224-30	C42	Condenser, line by-pass, .047 $\mu\text{f.}$	30-4650-45*
C20	Condenser, a-v-c decoupling, .01 $\mu\text{f.}$	30-4650-58*	C43	Condenser, line by-pass, 100 $\mu\text{f.}$	62-110001021*
C21	Condenser, cathode by-pass, 220 $\mu\text{f.}$	62-122001001*	C44	Condenser, r-f by-pass, 47 $\mu\text{f.}$	60-00475420
C22	Condenser, screen by-pass, .002 $\mu\text{f.}$	30-4650-54*	C45	Condenser, d-c blocking, 220 $\mu\text{f.}$	62-122001001
C23	Condenser, neutralizing, .006 $\mu\text{f.}$	30-4650-57*	CR1	Selenium rectifier, 100 ma., 117v	34-8003-1
C24	Condenser, i-f by-pass,		II	Pilot lamp, BC	34-2605

MODEL 53-958

Reference Symbol	Description	Service Part No.	Reference Symbol	Description	Service Part No.
I2	Pilot lamp, FM	34-2605	R21	Volume control (with off-on switch) 500,000 ohms	33-5566-44
J1	Connéctor, male, a-c	27-6240-5	R22	Resistor, grid return, 10 megohms	66-4478340*
J2	Connector, female, FM test	27-6180	R23	Resistor, plate load, 470,000 ohms	66-6108340*
L1	Coil, FM antenna tuning	32-4532A	R24	Resistor, grid return, 470,000 ohms	66-4478340*
L2	Coil, FM r-f	32-4415-2	R25	Resistor, cathode bias, 150 ohms	66-1158340*
L3	Choke, r-f	32-4061-3	R26	Resistor, filter, 470 ohms, 1 watt	66-1474340*
L4	Choke, r-f, 3.3 μ h.	32-4422-10	R27	Resistor, filter, 150 ohms, 2 watts	66-1155360*
L5	Coil, FM oscillator	32-4414-6	R28	Resistor, current limiting, 22 ohms, 2 watts	66-0225360*
L6	Choke, filament, 2.2 μ h.	32-4422-8	R29	Resistor, current limiting	33-1343-3
L7	Choke, filament, 2.2 μ h.	32-4422-8	R30	Resistor, loading, 100 ohms	66-1108340
L8	Choke, r-f, 3.3 μ h.	32-4422-10	S1	Switch, off-on	Part of R21
L9	Secondary, r-f transformer	Part of T2	T1	Transformer, AM oscillator	32-4569-1
L10	Primary, r-f transformer	Part of T2	T2	Transformer, AM r-f	32-4572
LA1	AM loop and support assembly	76-7836-1	T3	Transformer, output	32-8596
LA2	Line-cord aerial, FM	Part of Back Assembly	W1	Line cord	Part of Back Assembly
LS1	Speaker	36-1641-14	WS	Switch, band, 4-wafer	42-1991
PC1	Printed circuit, parasitic suppressor	30-6002	Z1	Transformer, FM 1st i-f	32-4518A
R1	Resistor, cathode bias, 120 ohms	66-1128340*	Z2	Transformer, AM 1st i-f	32-4516A
R2	Resistor, screen decoupling, 470 ohms	66-1478340*	Z3	Transformer, FM 2nd i-f	32-4518-1A
R3	Resistor, grid return, 15,000 ohms	66-3158340*	Z4	Transformer, FM detector	32-4310-4A
R4	Resistor, grid return, 2.2 megohms	66-5228340*	Z5	Transformer, AM 2nd i-f	32-4517A
R5	Resistor, parasitic suppressor, 2200 ohms	66-2228340*			
R6	Resistor, parasitic suppressor, 470 ohms	Part of PC1	MISCELLANEOUS		
R7	Resistor, cathode bias, 33 ohms	66-0338340*	Description	Service Part No.	
R8	Resistor, plate dropping, 47,000 ohms	66-3478340*	Cabinet	10950	
R9	Resistor, plate dropping, 4700 ohms	66-2478340*	Cabinet back assembly	76-7991	
R10	Resistor, cathode bias, 47 ohms	66-0478340*	Clip, pilot lamp	56-3545FA3	
R11	Resistor, screen decoupling, 1000 ohms	66-2108340*	Dial backplate, R.H.	56-9932	
R12	Resistor, plate decoupling, 680 ohms	66-1688340*	Dial backplate, L.H.	56-9932-1	
R13	Resistor, grid return, 1 megohm	66-5108340*	Dial scale, R.H.	54-5159	
R14	Resistor, cathode bias, 120 ohms	66-1128340*	Dial scale, L.H.	54-5159-1	
R15	Resistor, a-v-c filter, 2.2 megohms	66-5228340*	Drive cord, 25-foot spool	45-8750*	
R16	Resistor, decoupling, 470 ohms	66-1478340*	Knob, FM-AM	54-4774-28	
R17	Resistor, FM diode load, 47,000 ohms	66-3478340*	Knob, tuning	54-4774-26	
R18	Resistor, de-emphasis, 47,000 ohms	66-3478340*	Knob, volume-off-on	54-4774-27	
R19	Resistor, i-f filter, 47,000 ohms	66-3478340*	Pointer (2)	56-5630-49	
R20	Resistor, a-v-c load, 3.3 megohms	66-5338340*	Shaft, tuning	56-7931-4	
			Spring, gang drive	56-2617	
			Spring, pointer drive	28-8954	
			Socket, 12BA6 i-f ampl.	27-6265	
			Socket, 12AU6 i-f ampl.	27-6265	
			Socket, 12BA6 r-f ampl.	27-6275-1	
			Socket, 12AT7	27-6203-6	
			Socket, 19V8	27-6203-6	
			Socket, 35C5	27-6203-12	
			Shield, tube (2)	56-5629-3	
			Shield, tube base (1)	56-3978-1FA3	
			Shield, tube base (2)	56-5628-1FA3	
			Socket assembly, pilot lamps (2)	27-6233-21	
			Spring, hairpin	28-8610	

SPECIFICATIONS

MODEL 53-702.....Molded plastic
 MODELS 53-706, 53-707.....Wood
 CIRCUIT.....Five-tube Superheterodyne (plus rectifier)
 FREQUENCY RANGES
 Standard Broadcast.....540—1620 kc.
 Special Services.....1700—3400 kc.
 AUDIO OUTPUT.....1 watt

OPERATING VOLTAGE.....117 volts, a.c.
 POWER CONSUMPTION.....30 watts
 AERIAL.....High-impedance loop
 INTERMEDIATE FREQUENCY.....455 kc.
 PHILCO TUBES.....12BE6 converter, 12BA6 i-f amplifier,
 12AV6 det.—a.v.c.—1st audio,
 35C5 output, 35W4 rectifier

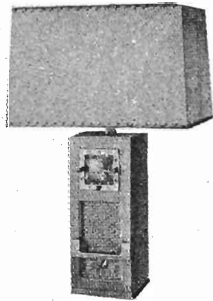

MODEL 53-706

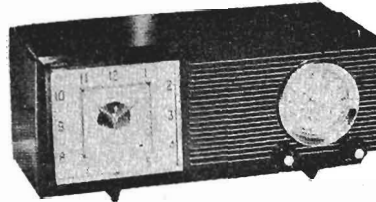

MODEL 53-702

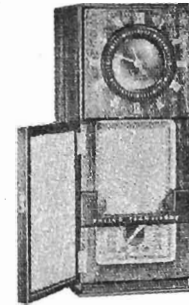

MODEL 53-707

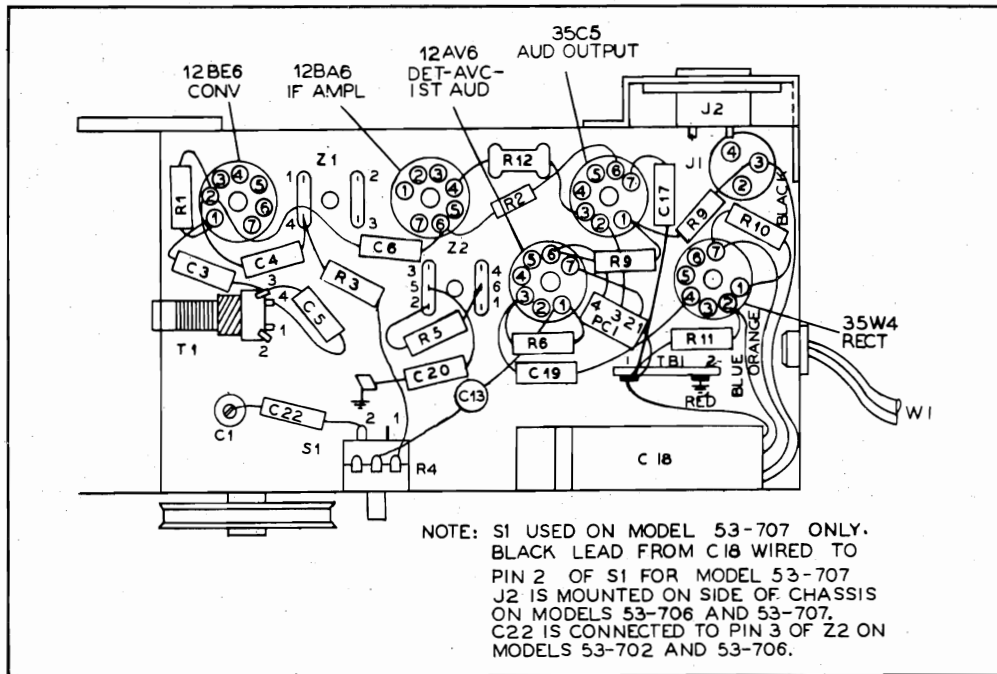

Figure 1. Base View, Showing Parts Placement

TP2-2277

PR-2418

MODELS 53-702,
53-706, 53-707

ALIGNMENT PROCEDURE

RADIO CONTROLS—Set volume control to maximum. Set tuning control and band switch as indicated in chart.

OUTPUT METER—Connect across voice-coil terminals.

SIGNAL GENERATOR—Connect generator and set frequency as indicated in chart. Use modulated output.

OUTPUT LEVEL—During alignment, adjust signal-generator output to hold output-meter reading below 1.25 volts.

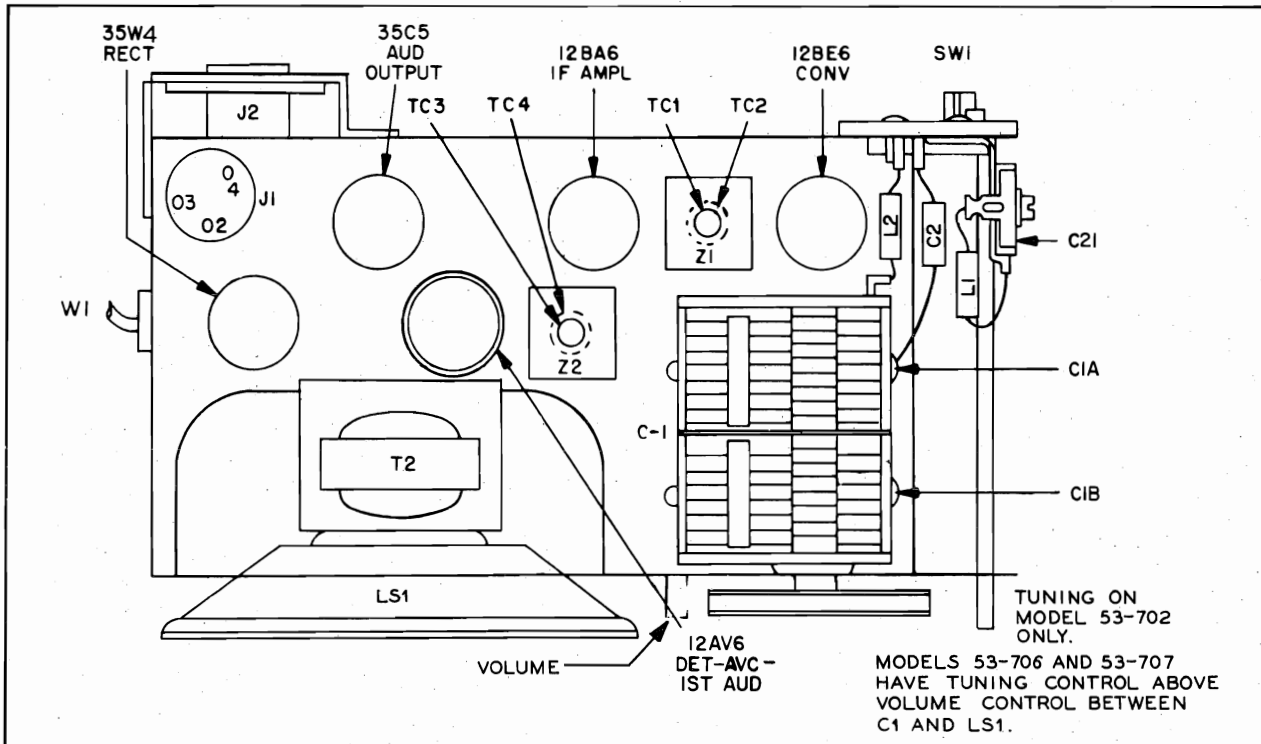

Figure 2. Top View, Showing Trimmer Locations

TP2-2278

ALIGNMENT CHART

STEP	SIGNAL GENERATOR		RADIO			ADJUST
	CONNECTION TO RADIO	DIAL SETTING	DIAL SETTING	BAND SWITCH SETTING	SPECIAL INSTRUCTIONS	
1	Ground lead to B-; output lead through a .1- μ f. condenser to grid (pin 7) of 12BE6.	455 kc.	Tuning gang fully open	Broadcast	Adjust tuning cores, in order given, for maximum output. (TC1 and TC3 are located at top of transformers.)	TC4—2nd i-f sec. TC3—2nd i-f pri. TC2—1st i-f sec. TC1—1st i-f pri.
2	Radiating loop (See note below).	1620 kc.	\approx 1620 kc.	Broadcast	Adjust trimmer for maximum output.	C1-B—osc.
3	Same as step 2.	1500 kc.	1500 kc.	Broadcast	Adjust trimmer for maximum output.	C1-A—aerial (broadcast)
4	Same as step 2.	3200 kc.	3200 kc.	Special Services	Adjust trimmer for maximum output.	C21—aerial (special services)

NOTE: Make up a 6–8 turn, 6-inch-diameter loop from insulated wire; connect to signal-generator leads, and place near radio loop.

*For proper adjustment of the oscillator trimmer, fully open the tuning gang and insert a .006-inch, non-metallic shim between the heel of the rotor and the top of the stator plates. Close the tuning gang sufficiently to hold the shim in place, and then remove the shim without disturbing the gang setting.

MODELS 53-702,
53-706, 53-707

PARTS LIST

NOTE: Part numbers identified by an asterisk (*) are general replacement items. These numbers may not be identical with those on factory parts. Also, the electrical values of some replacement items may differ from the values indicated in the schematic diagram and parts list. The values substituted in any case are so chosen that the operation will be either unchanged or improved. When ordering replacements, use only the "Service Part No."

Reference Symbol	Description	Service Part No.
CI	Condenser, tuning gang	31-2751-14
C1A	Condenser, r-f trimmer	Part of C1
C1B	Condenser, oscillator trimmer	Part of C1
C2	Condenser, aerial series tracker, 944 μ f.	30-1220-65
C3	Condenser, oscillator grid, 47 μ f.	30-1230-4
C4	Condenser, a-v-c by-pass, .05 μ f.	30-4650-45*
C5	Condenser, drift compensation, 7.5 μ f.	30-1224-83
C6	Condenser, screen by-pass, .05 μ f.	30-4650-45*
C7	Condenser, i-f tuning	Part of Z1
C8	Condenser, i-f tuning	Part of Z1
C9	Condenser, i-f tuning	Part of Z2
C10	Condenser, i-f tuning	Part of Z2
C11	Condenser, detector filtering	Part of Z2
C12	Condenser, detector filtering	Part of Z2
C13	Condenser, audio coupling, .005 μ f.	30-1238-1*
C14	Condenser, plate by-pass	Part of PC1
C15	Condenser, audio coupling, .005 μ f.	Part of PC1
C16	Condenser, compensating	Part of PC1
C17	Condenser, tone compensation, .022 μ f.	30-4650-43*
C18	Condenser, electrolytic, 3-section	30-2573
C18A	Condenser, filter, 30 μ f., 150v.	Part of C18
C18B	Condenser, filter, 25 μ f., 150v.	Part of C18
C18C	Condenser, filter, 20 μ f., 150v.	Part of C18
C19	Condenser, line by-pass, .047 μ f.	30-4650-45*
C20	Condenser, B minus to chassis, .1 μ f.	30-4650-47*
C21	Condenser, trimmer, special services.	31-6473-29
C22	Condenser, a-v-c decoupling, 220 μ f.	62-122001001*
I1	Lamp, pilot	34-2068
J1	Jack, clock	27-6273
J2	Jack, appliance receptacle, a-c	76-3931
L1	Coil, aerial, special services	32-4561-3
L2	Coil, oscillator shunt	32-4562-2
LA1	Loop, antenna	Part of back-and-loop ass'y
LS1	Speaker, p-m	36-1627-8
PC1	Coupling network	30-6001
PL1	Plug, clock assembly	54-4878-2
R1	Resistor, oscillator grid, 22,00 ohms	66-3228340*
R2	Resistor, i-f screen dropping, 4700 ohms	66-2478340*
R3	Resistor, a-v-c filter, 2.2 megohms	66-5228340*
R4	Resistor, volume control, .5 megohm Model 702	33-5565
	Model 706	33-5565-50
	Model 707	33-5566-49
R5	Resistor, diode load, 47,000 ohms	66-3478340*
R6	Resistor, grid return, 10 megohms	66-6108340*
R7	Resistor, plate load, 500,000 ohms	Part of PC1
R8	Resistor, grid return, 500,000 ohms	Part of PC1
R9	Resistor, cathode bias, 150 ohms	66-1158340*
R10	Resistor, B plus filter, 220 ohms, 1 watt.	66-1224340*
R11	Resistor, B plus filter, 1000 ohms.	66-2108340*
R12	Resistor, tube saver, 100 ohms	33-1343-3
S1	Switch, off-on	Part of R4
SW1	Switch, broadcast-special services	42-1796-2
T1	Transformer, oscillator	32-4453-6
T2	Transformer, output	32-8384*
W1	Line cord	L-2183*
Z1	Transformer, 1st i-f	32-4161A
Z2	Transformer, 2nd i-f	32-4240A

Reference Symbol	Description	Service Part No.
MISCELLANEOUS		
PARTS COMMON TO ALL MODELS		
Description	Service Part No.	
Shield, tube	56-5629FA3	
Shield, tube base	56-3978FA3	
Socket, tube (5)	27-6265	
Socket assembly, pilot lamp	27-6233-6	
Spring, drive cord	56-2617	
Spring, retaining	28-8610	
Drive cord, 25-ft. spool	45-8750*	
MODEL 53-702		
Cabinet		
Maroon	10940	
Biege	10940-2	
Knobs		
Maroon		
Clock (3)	54-4983	
Tuning and volume	54-4986	
Biege		
Clock (3)	54-4983	
Tuning and volume	54-4986-1	
Clock	41-1042-1	
Back-and-loop assembly		
Maroon	76-7807	
Biege	76-7807-1	
Backplate and clip assembly, pilot lamp	76-7808	
Scale		
Radio	54-4985	
Clock	54-4984	
Pointer	56-9846	
Clock cover	54-4989	
Shaft, tuning	56-9807	
MODEL 53-706		
Cabinet		
Mahogany	10952	
Blond	10952-1	
Knobs		
Mahogany		
Clock (3)	54-4983-3	
Tuning and volume	54-4557-6	
Blond		
Clock (3)	54-4983-3	
Tuning and volume	54-4557-7	
Clock	41-2043	
Back-and-loop assembly	76-8004	
Lamp attachment	40-8916	
Scale, radio	54-5160	
Pointer		
Mahogany	56-10043	
Blond	56-10043-1	
Clock cover	54-4989	
Shaft, tuning	56-10012	
MODEL 53-707		
Cabinet	10955	
Knobs		
Clock (3)	54-4983-3	
Tuning and volume	54-4557-6	
Clock	41-2042-2	
Back-and-loop assembly	76-8004	
Scale, radio	54-5160	
Pointer	56-10043	
Shaft, tuning	56-10012	
Door, cabinet	45-6735	
Hook, door	56-10049	
Hinge, door (2)	56-10048	

SPECIFICATIONS

CABINET.....	Plastic table model
CIRCUIT.....	Six-tube superheterodyne plus selenium rectifier
FREQUENCY RANGES	
Broadcast.....	540—1620 kc.
FM.....	88—108 mc.
AUDIO OUTPUT.....	1 watt
OPERATING VOLTAGE.....	105—125 volts, a.c./d.c.
POWER CONSUMPTION.....	45 watts
AERIAL.....	Built-in. pancake loop for AM, line cord for FM; provision for connecting external aerial
INTERMEDIATE FREQUENCY	
AM.....	455 kc.
FM.....	9.1 mc.
PHILCO TUBES (6).....	12AU6 r-f ampl., 12AT7 converter, 12BA6 1st i-f ampl., 12AU6 2nd i-f ampl., 19Y8 def.-a.v.c.-1st audio, 35C5GT output

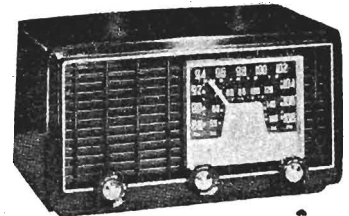

MODEL 53-956

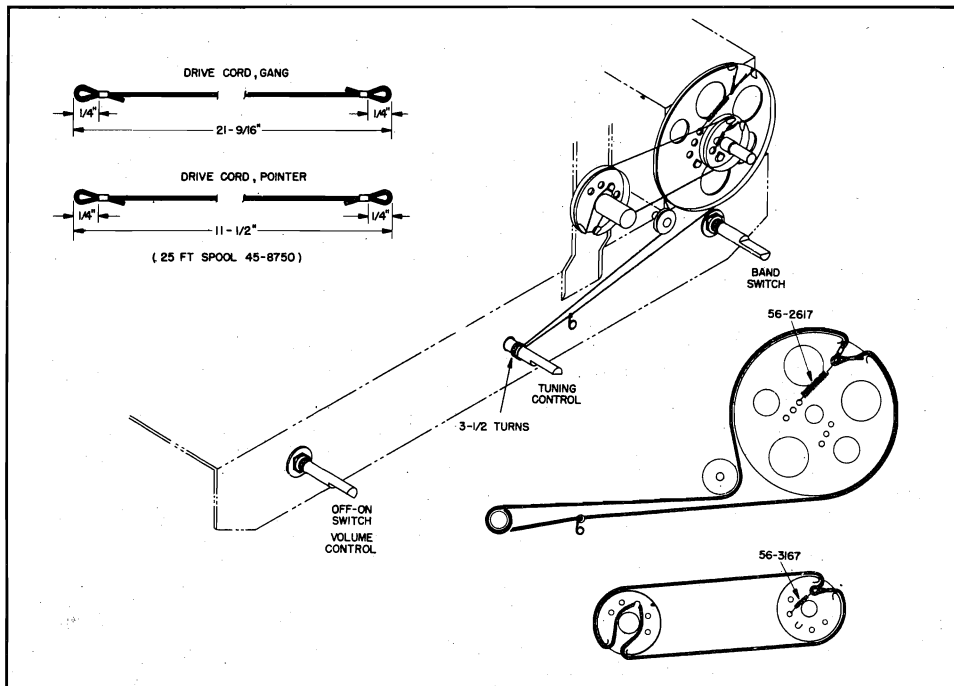

TP2-226Q

Figure 1. Drive-Cord Installation Details

PR-2420

MODEL 53-956

AM ALIGNMENT PROCEDURE

Make alignment with loop aerial connected to radio. The AM alignment should be completed before the FM alignment is made.

DIAL POINTER—With tuning-condenser plates fully meshed, adjust pointer to coincide with index mark at low-frequency end of dial backplate.

RADIO CONTROLS—Set volume control to maximum, set band switch for broadcast reception, and set tuning control as indicated in chart.

OUTPUT METER—Connect across voice-coil terminals.

SIGNAL GENERATOR—Use AM r-f signal generator, with modulated output. Connect generator and set frequency as indicated in chart.

OUTPUT LEVEL—During alignment, signal-generator output must be attenuated to hold output-meter reading below 1.25 volts.

AM ALIGNMENT CHART

STEP	SIGNAL GENERATOR		RADIO		ADJUST
	CONNECTION TO RADIO	DIAL SETTING	DIAL SETTING	SPECIAL INSTRUCTIONS	
1	Ground lead to chassis. Output lead through a .1- μ f. condenser to junction of LA1 and L8.	455 kc.	Gang fully open.	Adjust for maximum output, in order given.	TC10—2nd AM i-f sec. TC9—2nd AM i-f pri. TC4—1st AM i-f sec. TC3—1st AM i-f pri.
2	Radiating loop (see note below).	1620 kc.	1620 kc. (2nd index mark from right).	Adjust for maximum output.	C1C—osc. trimmer.
3	Same as step 2.	1500 kc.	1500 kc.	Adjust for maximum output.	C1A—aerial trimmer.

RADIATING LOOP: Make up a six-to-eight turn, 6-inch-diameter loop from insulated wire; connect to generator terminals, and place near radio loop aerial. Radio loop aerial must be connected.

FM ALIGNMENT PROCEDURE

Make AM alignment first

RADIO CONTROLS—Set volume control to maximum, set band switch for FM reception, and set tuning control as indicated in chart.

OSCILLOSCOPE—Connect ground lead to chassis. Connect vertical input to FM TEST jack, J2; connect horizontal input to horizontal sweep output of sweep generator. (Oscilloscope is used for steps 1 and 2.)

SWEEP GENERATOR—Use FM r-f sweep signal generator. Connect output lead as given in chart. Set frequency and sweep width as indicated in chart.

OUTPUT METER—Connect across voice-coil terminals.

NOTE: Before starting FM alignment, allow radio and signal generator to warm up for 15 minutes.

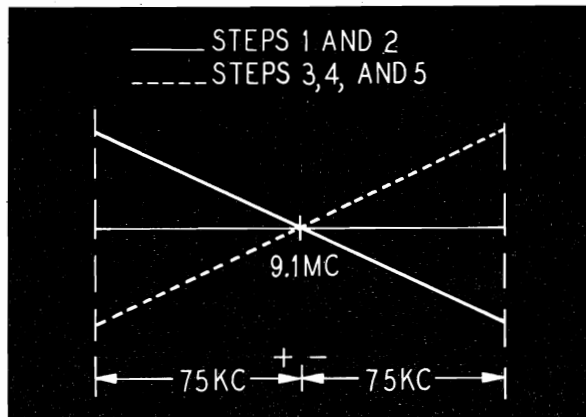

TPI-2111

Figure 2. Characteristic Curve of FM Detector

FM ALIGNMENT CHART

STEP	SIGNAL GENERATOR		RADIO		ADJUST
	CONNECTION TO RADIO	DIAL SETTING	DIAL SETTING	SPECIAL INSTRUCTIONS	
1	Ground lead to chassis. Output lead through a .01- μ f. condenser to control grid (pin 1) of 12AU6 2nd i-f amplifier.	9.1 mc. (75-kc. deviation).	88mc. (gang meshed).	Balance and adjust detector for maximum indication on scope, as shown in figure 2.	TC8—detector sec. TC7—detector pri.

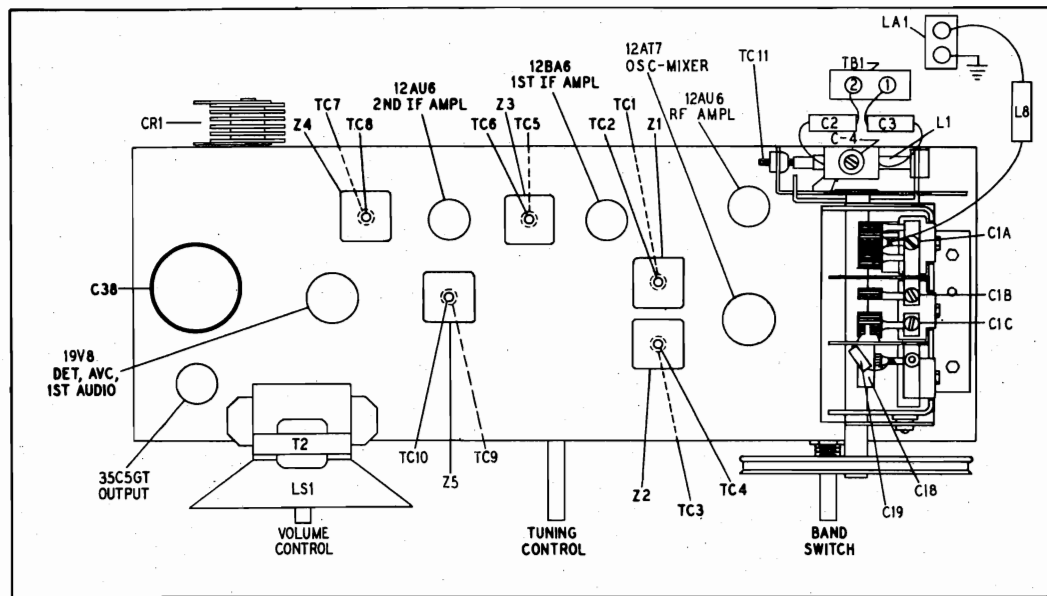

TP2-2261

Figure 3. Top View, Showing Trimmer Locations

FM ALIGNMENT CHART (Cont.)

STEP	SIGNAL GENERATOR		RADIO		ADJUST
	CONNECTION TO RADIO	DIAL SETTING	DIAL SETTING	SPECIAL INSTRUCTIONS	
2	Ground lead to chassis. Output lead through a .01- μ f. condenser to FM tuning gang stator lug, junction of C1 and pin 4 of L2.	Same as step 1.	Same as step 1.	Adjust for maximum indication on scope, as shown in figure 2.	TC6—FM 2nd i-f sec. TC5—FM 2nd i-f pri. TC2—FM 1st i-f sec. TC1—FM 1st i-f pri.
3	Ground lead to lug 3 of TB1. Output lead to lug 2 of TB1. See note 1 below.	108.5 mc.	108.5 mc. (1st index mark from right).	Adjust for maximum indication on output meter.	C18—FM osc.
4	Same as step 3.	88 mc.	88 mc. (1st index mark from left).	Adjust for maximum indication on output meter. See note 2 below.	L5—FM osc.
5	Same as step 3.	105 mc.	105 mc. (3rd index mark from right).	Adjust for maximum indication on output meter while rocking tuning condenser.	C1B—FM r-f.
6	Same as step 3.	105 mc.	105 mc.	Adjust for maximum indication on output meter.	C4—FM aerial.
7	Same as step 3.	92 mc.	92 mc. (3rd index mark from left).	Adjust for maximum indication on output meter. See note 3 below.	L2—FM r-f coil.
If FM aerial coil, L1, is replaced, it should be adjusted as directed in step 8, below.					
8	Same as step 3.	92 mc.	92 mc.	Adjust for maximum indication on output meter.	TC11—FM aerial.

NOTE 1: For accurate results, the signal-generator output impedance must be 300 ohms, to match the input impedance of TB1. If the generator impedance is less than 300 ohms, a resistor of the proper value may be used in series with the output lead to make the impedance correct. For example, if the output impedance is 150 ohms, place a 150-ohm resistor in series with the output lead.

NOTE 2: If oscillator does not tune as low as 88 mc., compress the turns on the oscillator coil. If oscillator tunes too low, spread the turns slightly. After coil is adjusted, repeat step 3.

NOTE 3: Check resonance of coil L2 by inserting end of a tuning wand, such as Philco Part No. 56-6100, in the coil. If output increases when iron end is placed in coil, compress turns slightly. If output increases when brass end is placed in coil, spread the turns. If output decreases when either end is placed in coil, no adjustment is necessary. After the coil is adjusted, readjust trimmer C1B and repeat steps 3 through 8 until no further improvement is obtained.

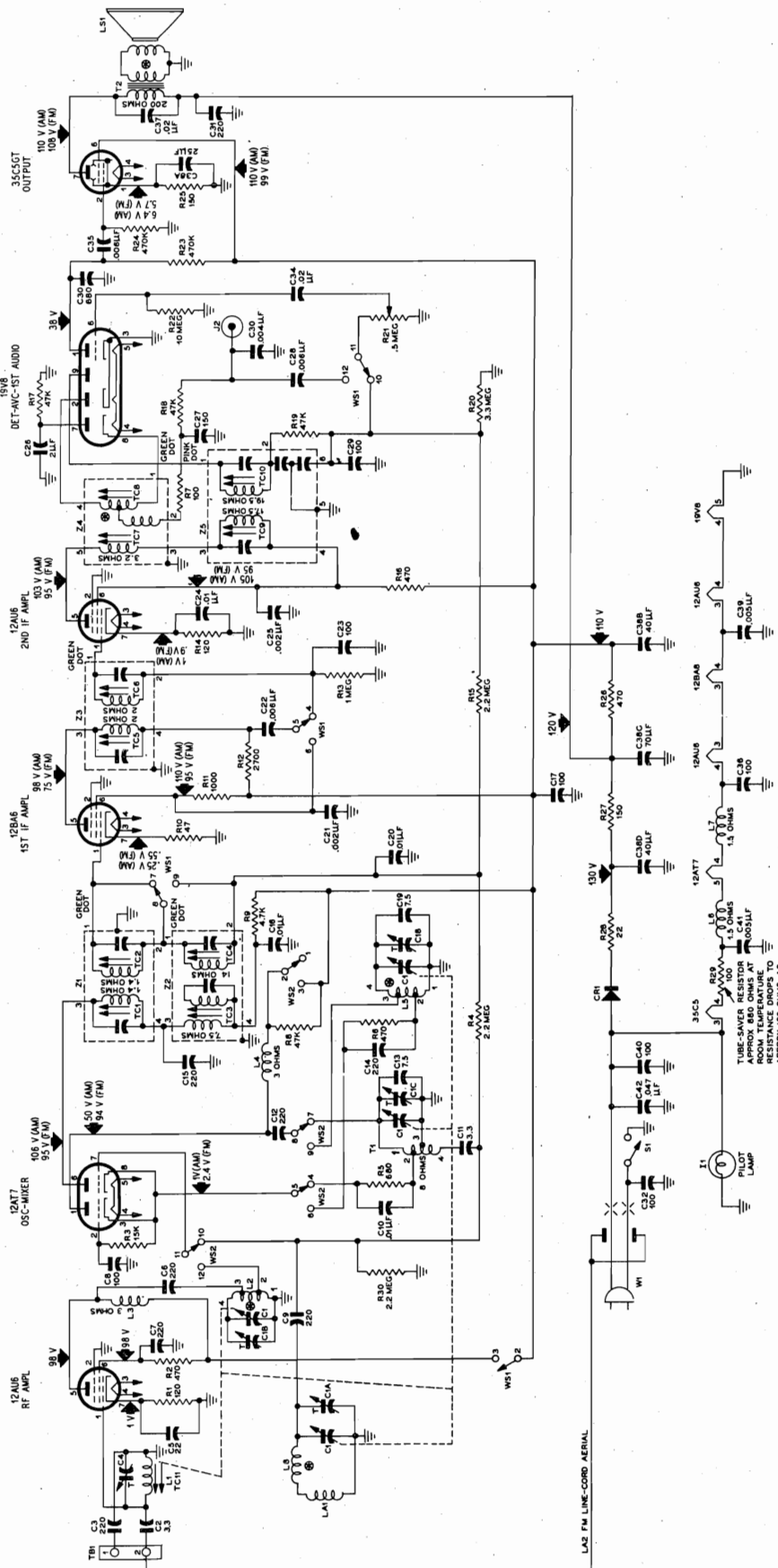

CAUTION-ONE SIDE OF AC LINE IS CONNECTED DIRECTLY TO CHASSIS

NOTES:
 ALL RESISTOR VALUES IN OHMS AND ALL CONDENSER VALUES IN MICROFARADS UNLESS OTHERWISE SPECIFIED
 ALL VOLTAGE VALUES ARE IN VOLTS UNLESS OTHERWISE SPECIFIED
 BETWEEN POINTS INDICATED AND B MINUS, AT A LINE VOLTAGE OF 117 V AC
 ● LESS THAN ONE OHM

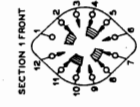
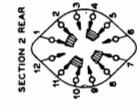
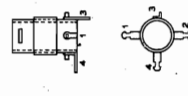
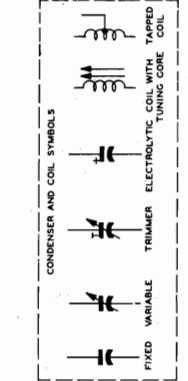

2. SECTION WATER SWITCH SHOWN IN BROADCAST POSITION AS VIEWED FROM FRONT WITH CHASSIS INVERTED WS1, FROM FRONT TO REAR

BC FM WS

PARTS LIST

NOTE: Part numbers identified by an asterisk (*) are general replacement items. These numbers may not be identical with those on factory parts; also, the electrical values of some replacement items may differ from the values indicated in the schematic diagram and parts list. The values substituted in any case are so chosen that the operation of the radio will be either unchanged or improved. When ordering replacements, use only the "Service Part No."

Reference Symbol	Description	Service Part No.	Reference Symbol	Description	Service Part No.
C1	Condenser, tuning gang, 5-section	31-2762-1	C38D	Condenser, filter, 40 μ f., 150v	Part of C38
C1A	Condenser, trimmer, BC aerial	Part of C1	C39	Condenser, filament by-pass, .005 μ f.	30-1238-1*
C1B	Condenser, trimmer, FM r-f	Part of C1	C40	Condenser, line by-pass, 100 μ f.	62-110001021*
C1C	Condenser, trimmer, BC oscillator	Part of C1	C41	Condenser, filament by-pass, .005 μ f.	30-1238-1*
C2	Condenser, aerial isolating, 3.3 μ f.	30-1221	C42	Condenser, line by-pass, .047 μ f.	30-4650-45*
C3	Condenser, aerial isolating, 220 μ f.	62-122001001*	CR1	Selenium rectifier, 100 ma., 117v.	34-8003-1
C4	Condenser, FM aerial trimmer	45-3034	I1	Pilot lamp, frosted, 117v, 7 watts	34-2605
C5	Condenser, cathode by-pass, 22 μ f.	62-022009001	J1	Jack, male, a-c	27-6240-5
C6	Condenser, d-c blocking, 220 μ f.	30-6002	J2	Socket, FM test	27-6180
C7	Condenser, screen by-pass, 220 μ f.	62-122001001*	L1	Coil, FM aerial, complete with grommet	32-4532A
C8	Condenser, oscillator grid, 100 μ f.	62-110001021*	L2	Coil, FM r-f	32-4415-2
C9	Condenser, d-c blocking, 220 μ f.	62-122001001*	L3	Choke, r-f, 3.3 μ h.	32-4422-10
C10	Condenser, cathode by-pass, .01 μ f.	30-4650-58*	L4	Choke, r-f, 3.3 μ h.	32-4422-10
C11	Condenser, neutralizing, 3.3 μ f.	30-1224-49	L5	Coil, FM oscillator	32-4414-5
C12	Condenser, d-c blocking 220 μ f.	62-122001001*	L6	Choke, filament, 2.2 μ h.	32-4422-8
C13	Condenser, fixed trimmer, 7.5 μ f.	30-1224-65	L7	Choke, filament, 2.2 μ h.	32-4422-8
C14	Condenser, cathode by-pass, 220 μ f.	62-122001001*	L8	Choke, r-f, 4.1 μ h.	32-4061-3
C15	Condenser, r-f by-pass, 220 μ f.	62-122001001*	LA1	AM loop and support assembly	76-7836
C16	Condenser, plate decoupling, .01 μ f.	30-4650-58*	LA2	Line-cord aerial, FM	Part of W1
C17	Condenser, r-f by-pass, 100 μ f.	62-110009001*	LS1	Speaker, 4" p-m, including output transformer	36-1625-14
C18	Condenser, trimmer, FM oscillator	31-6511-10	R1	Resistor, cathode bias, 120 ohms.	66-1128340*
C19	Condenser, fixed trimmer, 7.5 μ f.	30-1224-8	R2	Resistor, screen decoupling, 470 ohms	66-1478340*
C20	Condenser, a-v-c decoupling, .01 μ f.	30-4650-58*	R3	Resistor, grid return, 15,000 ohms	66-3158340*
C21	Condenser, screen by-pass, .002 μ f.	30-4650-54*	R4	Resistor, grid return, 2.2 megohms	66-5228340*
C22	Condenser, neutralizing, .006 μ f.	30-4650-57*	R5	Resistor, parasitic suppressor, 680 ohms	66-1688340*
C23	Condenser, i-f by-pass, 100 μ f.	62-110001021*	R6	Resistor, parasitic suppressor, 470 ohms	66-1478340*
C24	Condenser, cathode by-pass, .01 μ f.	30-4650-58*	R7	Resistor, loading, 100 ohms	66-1108340*
C25	Condenser, screen by-pass, .002 μ f.	30-4650-54*	R8	Resistor, plate dropping, AM, 47,000 ohms	66-3478340*
C26	Condenser, electrolytic, diode-load filter, 2 μ f., 50v	30-2417-7	R9	Resistor, plate dropping, 4700 ohms.	66-2478340*
C27	Condenser, i-f by-pass, 150 μ f.	62-115001011*	R10	Resistor, cathode bias, 47 ohms	66-0478340*
C28	Condenser, d-c blocking, .006 μ f.	30-4650-57*	R11	Resistor, screen decoupling, 1000 ohms	66-2108340*
C29	Condenser, i-f by-pass, 100 μ f.	62-110001021*	R12	Resistor, plate decoupling, 2700 ohms	66-2278340*
C30	Condenser, de-emphasis, .004 μ f.	30-4650-56*	R13	Resistor, grid return, 1 megohm	66-5108340*
C31	Condenser, plate decoupling, 220 μ f.	62-122001001*	R14	Resistor, cathode bias, 120 ohms	66-1128340*
C32	Condenser, line by-pass, 100 μ f.	62-110001021*	R15	Resistor, a-v-c filter, 2.2 megohms	66-5228340*
C33	Condenser, plate by-pass, 680 μ f.	62-168001001*	R16	Resistor, decoupling, 470 ohms	66-1478340*
C34	Condenser, d-c blocking, .02 μ f.	30-4650-60*	R17	Resistor, FM diode load, 47,000 ohms	66-3478340*
C35	Condenser, d-c blocking, .006 μ f.	30-4650-57*	R18	Resistor, de-emphasis, 47,000 ohms.	66-3478340*
C36	Condenser, filament by-pass, 100 μ f.	62-110001021*	R19	Resistor, i-f filter, 47,000 ohms	66-3478340*
C37	Condenser, tone compensation, .02 μ f.	30-4650-60*	R20	Resistor, a-v-c load, 3.3 megohms	66-5338340*
C38	Condenser, electrolytic, 4-section	30-4650-46	R21	Volume control (with off-on switch) 500,000 ohms	33-5566-20
C38A	Condenser, cathode by-pass, 25 μ f., 25v	Part of C38	R22	Resistor, grid return, 10 megohms	66-6108340*
C38B	Condenser, filter, 40 μ f., 150v	Part of C38	R23	Resistor, plate load, 470,000 ohms	66-4478340*
C38C	Condenser, filter, 70 μ f., 150v	Part of C38	R24	Resistor, grid return, 470,000 ohms	66-4478340*

Reference Symbol	Description	Service Part No.
R25	Resistor, cathode bias, 150 ohms	66-1158340°
R26	Resistor, filter, 470 ohms, 1 watt	66-1474340°
R27	Resistor, filter, 150 ohms, 2 watts	66-1155360°
R28	Resistor, current limiting, 22 ohms, 2 watts	66-0225360°
R29	Resistor, current limiting, 100 ohms	33-1343-3
R30	Resistor, grid return, 2.2 megohms	66-5228340°
S1	Switch, off-on	Part of R21
T1	Transformer, AM oscillator	32-4569-1
T2	Transformer, output	Part of LS1
W1	Line cord	41-3865-3
W2	Cable, FM aerial, 72-ohm twin lead	41-3987
WS	Switch, band, 2-wafer	42-1924-1
Z1	Transformer, FM, 1st i-f	32-4518A
Z2	Transformer, AM, 1st i-f	32-4516A
Z3	Transformer, FM, 2nd i-f	32-4518-1A
Z4	Transformer, FM, detector	32-4310-4A
Z5	Transformer, AM, 2nd i-f	32-4517A

MISCELLANEOUS

Description	Service Part No.
Cabinet	10941
Back, flange, and socket assembly	76-7829

MISCELLANEOUS (Cont.)

Description	Service Part No.
Fastener, back mtg. (4)	W-2235-FA9
Dial scale	54-4987
Knob, FM-AM	54-4774-28
Knob, tuning	54-4774-26
Knob, volume-off-on	54-4774-27
Clip, pilot lamp	56-3545-FA3
Drive cord, 25-foot spool	45-8750°
Pointer	56-9906
Shaft, drive	56-7931FA11
Spring, gang drive	56-2617
Spring, pointer drive	56-3167
Rubber mount, speaker (2)	54-4651-1
Socket, 12BA6 (i-f ampl.)	27-6265
Socket, 12AU6 (i-f ampl.)	27-6265
Socket, 12AU6 (r-f ampl.)	27-6275-1
Socket, 12AT7	27-6203-6
Socket, 19V8	27-6203-6
Socket, 35C5	27-6203-12
Shield, tube (2)	56-5629-3
Shield, tube base (1)	56-3978-1FA3
Shield, tube base (2)	56-5628-1FA3
Socket, assembly, pilot lamp	27-6233-21
Spring, hairpin	28-8610

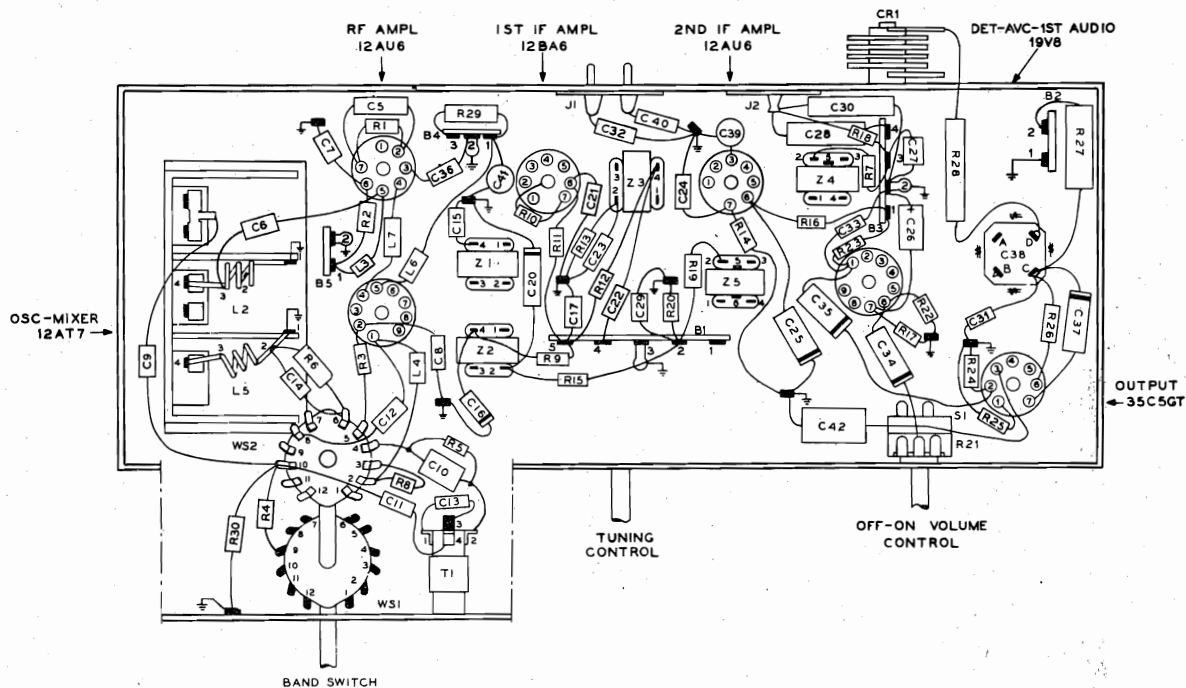

TP2-2263

Figure 5. Base View, Showing Parts Placement

Circuit Superheterodyne
 Frequency ranges
 Standard Broadcasts: .540 to 1.70 megacycles (555 to 176.5 meters)
 Short Wave 1: 1.7 to 5.3 megacycles (176.5 to 56.5 meters)
 Short Wave 2: 7.5 to 22.0 megacycles (40.0 to 13.62 meters)
 Band Spread:
 49-Meter Band: 5.2 to 7.6 megacycles (57.7 to 39.4 meters)
 31-Meter Band: 9.4 to 9.9 megacycles (31.9 to 30.3 meters)
 25-Meter Band: 11.4 to 12.0 megacycles (26.3 to 25 meters)
 19-Meter Band: 14.8 to 15.6 megacycles (20.3 to 19.2 meters)
 16-Meter Band: 17.3 to 18.2 megacycles (17.3 to 16.5 meters)
 13-Meter Band: 20.8 to 21.9 megacycles (14.4 to 13.7 meters)

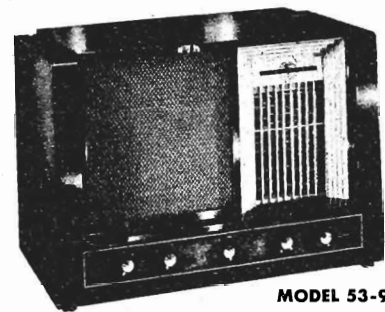

MODEL 53-960
 Number of tubes (excluding rectifier) 7
 Number of rectifier tubes 1
 Tone control Continuously variable
 Aerial Loop aerial for Standard Broadcast; whip aerial for Short Wave; provision for external aerial
 Operating voltage 115 volts, 60 cycles, a.c.
 Speaker 10-inch PM
 Undistorted power output 7 watts
 Total power consumption 110 watts

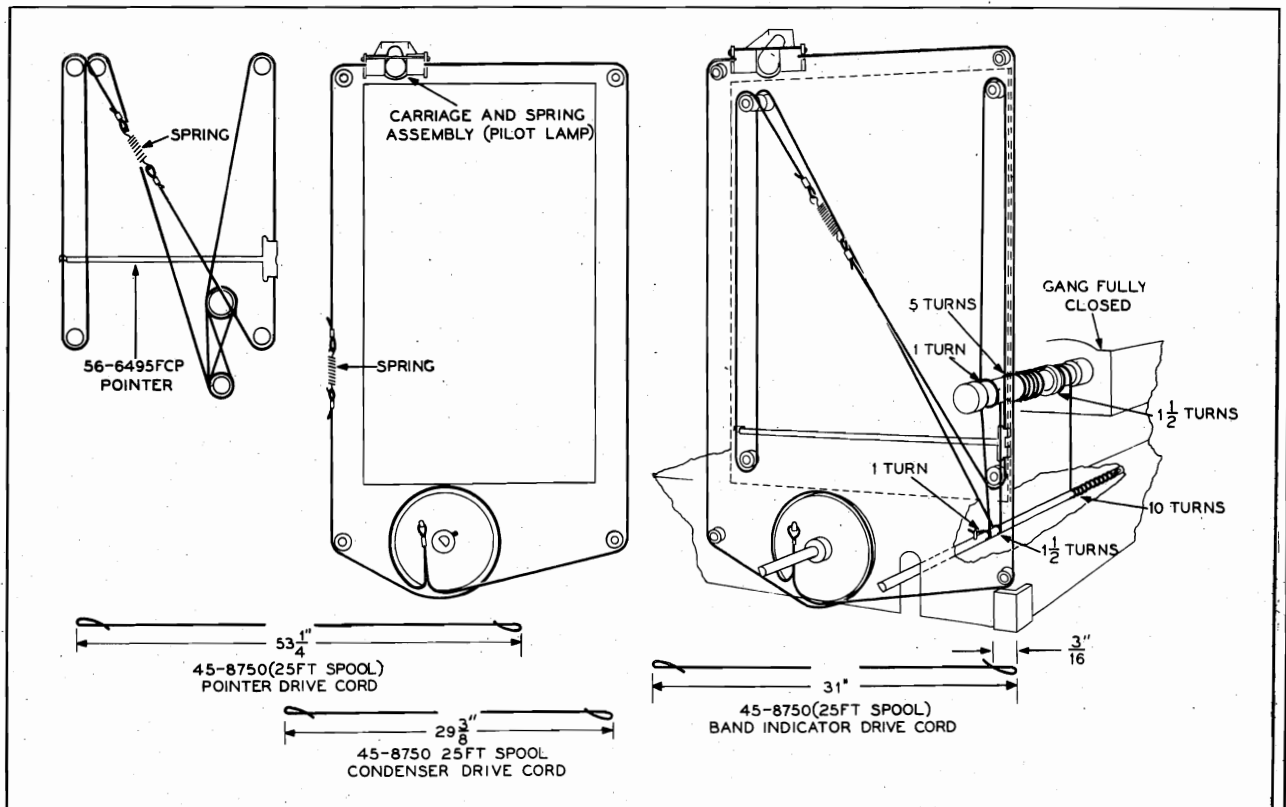

Figure 1. Drive-Cord Installation Details

PR-2385

MODEL 53-960

ALIGNMENT PROCEDURE

DIAL POINTER: With the tuning-condenser plates fully meshed, adjust the dial pointer to coincide with the index mark (the second mark below "55") at the low-frequency end of the dial.

BAND-SPREAD TUNING CORES: With the tuning control at the extreme low-frequency setting, set oscillator core TC1C flush with the rear end of the oscillator coil form. Aerial core TC1A and r-f core TC1B should now extend approximately 1/16 inch beyond their coil forms.

SIGNAL GENERATOR: Connect the ground lead to the chassis, and the output lead as indicated in the

chart. Set the signal-generator frequency as indicated in the chart, and use modulated output.

RADIO CONTROLS: Set the volume control to maximum, and the tone control fully clockwise. Set the band switch and tuning control as indicated in the chart.

OUTPUT METER: Connect between the voice-coil lug on the speaker and the chassis.

OUTPUT LEVEL: During alignment, the signal-generator output must be attenuated to maintain an output-meter reading below 1.5 volts.

STEP	SIGNAL GENERATOR		RADIO			ADJUST
	CONNECTION TO RADIO	DIAL SETTING	BAND SWITCH	DIAL SETTING	SPECIAL INSTRUCTIONS	
1	Through a .1- μ f. condenser to stator of r-f (center) section of Cl.	455 kc.	BC	Tuning gang fully open.	Adjust, in order given, for maximum output; then repeat.	C28—2nd i-f sec. C27—2nd i-f pri. C30—1st i-f sec. C29—1st i-f pri.
2	Through a 25- μ f. condenser to aerial terminal of TBl.	580 kc.	BC	580 kc.	Adjust for maximum output while rocking tuning control.	C14A—BC osc. (series)
3	Same as step 2.	1500 kc.	BC	1500 kc.	Adjust, in order given, for maximum output.	C13—BC osc. (shunt) C41—BC r-f C52—BC aerial
4	Through a 25- μ f. condenser to aerial terminal of TBl.	5.0 mc.	SW1	5.0 mc.	Adjust for maximum output.	C14B—SW1 osc.
5	Same as step 4.	7.5 mc.	BS1	7.5 mc.	Adjust, in order given, for maximum output.	C14C—BS1 osc. C7D—BS1 r-f C2D—BS1 aerial
6					Preset approximately $\frac{1}{2}$ turn from tight position.	C7I—SW2 osc. C7E—SW2 r-f C2E—SW2 aerial
7	Same as step 4.	9.0 mc.	SW2	9.0 mc.	Adjust, in order given, for maximum output.	TC13—SW2 osc. TC9—SW2 r-f TC5—SW2 aerial
8	Same as step 4.	21.0 mc.	SW2	21.0 mc.	Adjust, in order given, for maximum output. Repeat steps 7 and 8 until maximum output is obtained.	C7I—SW2 osc. C7E—SW2 r-f C2E—SW2 aerial
9	Same as step 4.	15.2 mc.	BS4	15.2 mc.	Adjust, in order given, for maximum output.	C7F—BS4 osc. C7C—BS4 r-f C2C—BS4 aerial
10	Same as step 4.	9.7 mc.	BS2	9.7 mc.	Adjust for maximum output.	C7H—BS2 osc.
11	Same as step 4.	11.7 mc.	BS3	11.7 mc.	Adjust for maximum output.	C7G—BS3 osc.
12	Same as step 4.	17.8 mc.	BS5	17.8 mc.	Adjust, in order given, for maximum output.	C24B—BS5 osc. C7B—BS5 r-f C2B—BS5 aerial
13	Same as step 4.	21.5 mc.	BS6	21.5 mc.	Adjust, in order given, for maximum output.	C24A—BS6 osc. C7A—BS6 r-f C2A—BS6 aerial

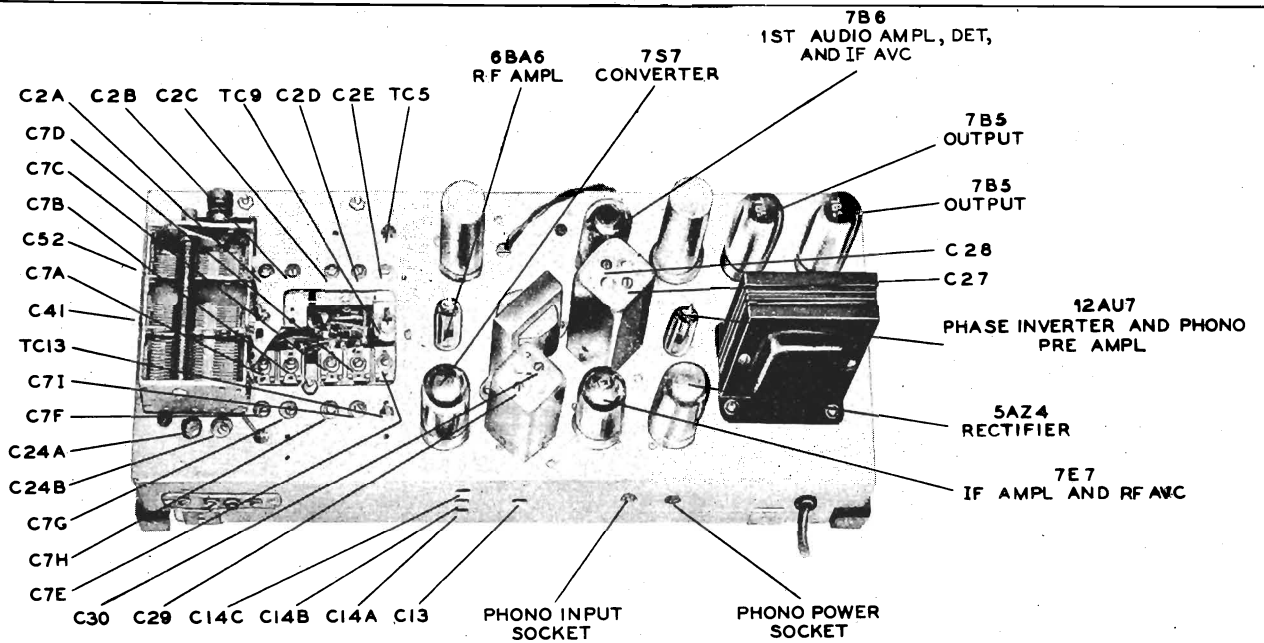

Figure 2. Top View, Showing Trimmer Locations

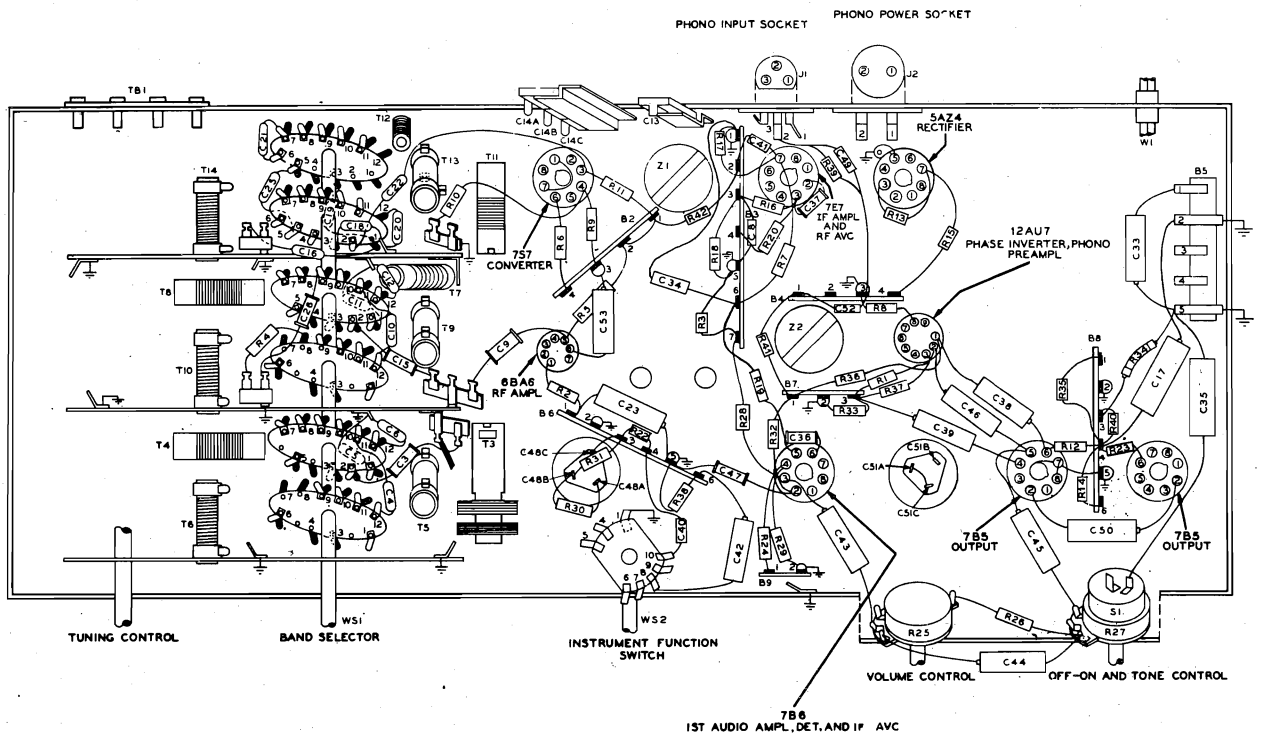
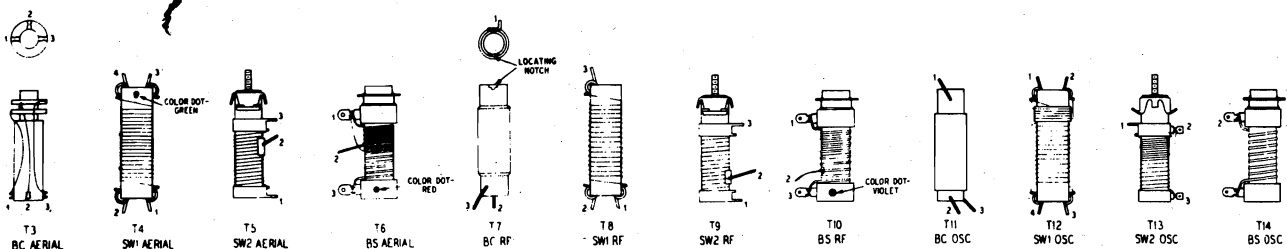
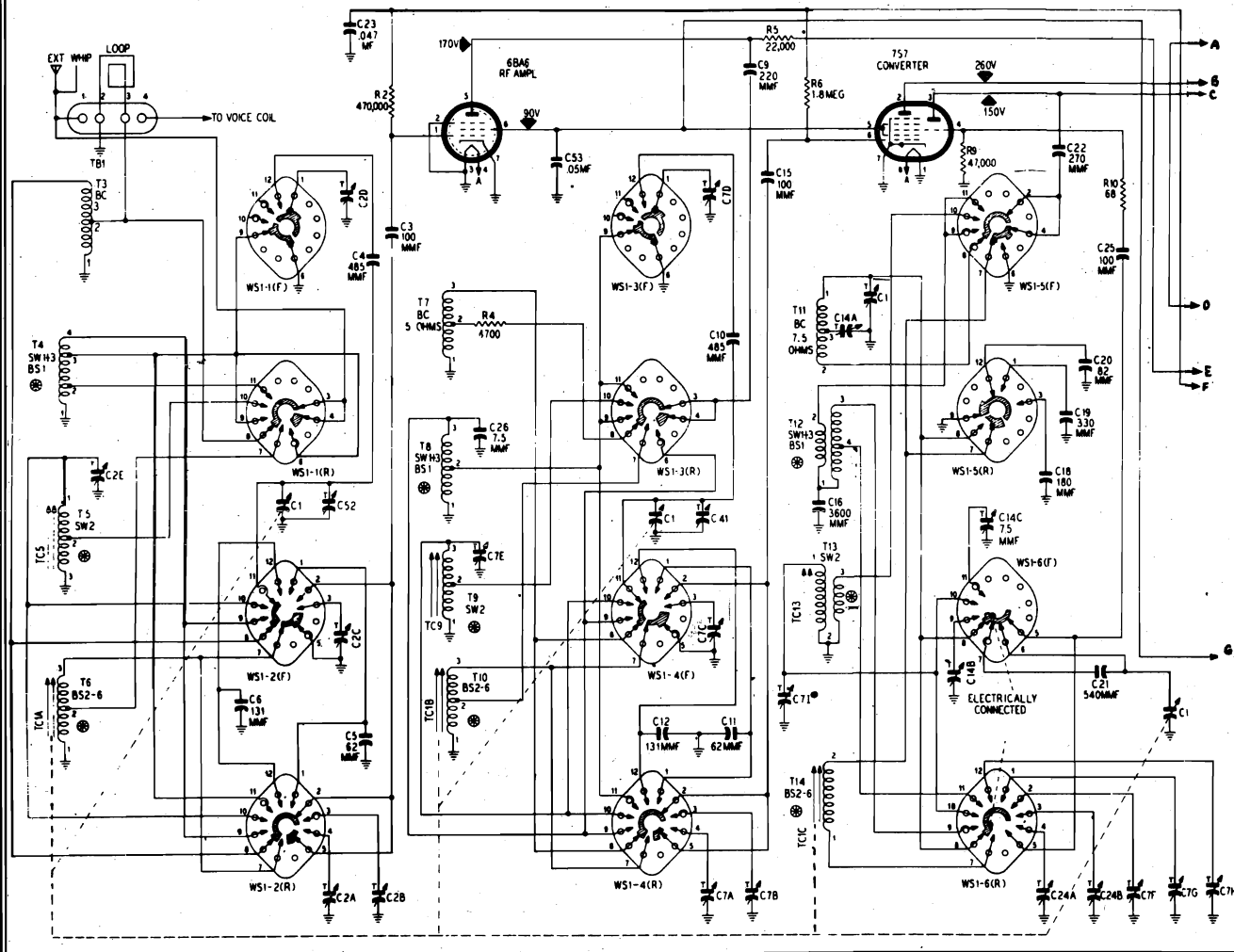
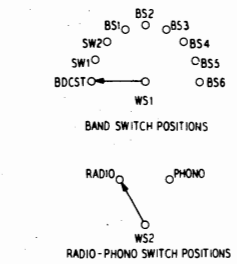
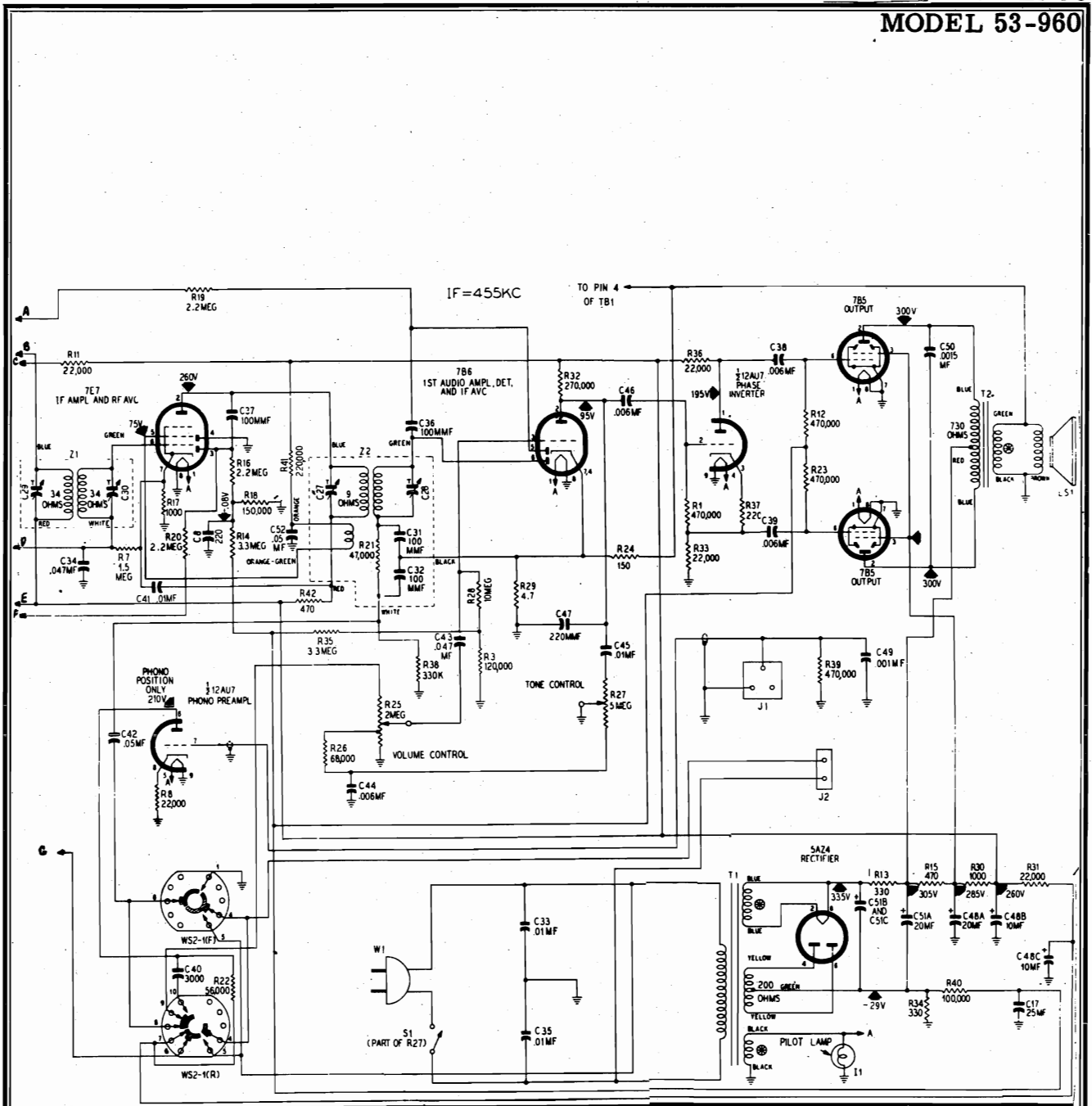
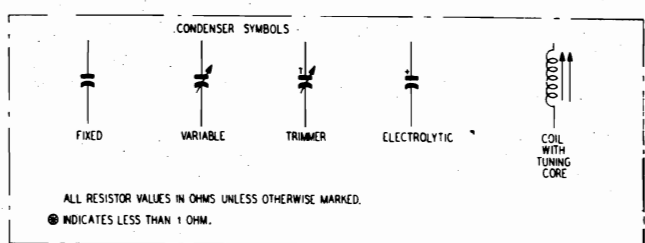

Figure 3. Bottom View, Showing Symbolized Chassis





WS1 SHOWN IN BC POSITION.
 WS2 SHOWN IN RADIO POSITION.
 WAFER SWITCH SECTIONS SYMBOLIZED WS1-1, WS1-2, ETC. FROM FRONT OF CHASSIS TOWARD REAR.
 (F) INDICATES FRONT CONTACTS LOOKING FROM KNOB END,
 (R) INDICATES REAR CONTACTS LOOKING THROUGH FROM KNOB END.
 ALL VOLTAGES SHOWN WERE MEASURED WITH 20,000 OHMS-PER-VOLT METER FROM POINTS INDICATED TO CHASSIS, AT A LINE VOLTAGE OF 117 V. AC.



MODEL 53-960

NOTE: Part numbers identified by an asterisk (*) are general replacement items. These numbers may not be identical with those on factory parts; also, the electrical values of some replacement items may differ from the values indicated in the schematic diagram and

PARTS LIST

parts list. The values substituted in any case are so chosen that the operation of the radio will be either unchanged or improved.

When ordering replacements, use only the "Service Part No."

Reference Symbol	Description	Service Part No.
C1	Condenser, tuning gang, 3-section	31-2741-2
C2	Condenser, trimmer, 5-section	31-6507-5
C2A	Condenser, aerial trimmer, 21.5 mc.	Part of C2
C2B	Condenser, aerial trimmer, 17.8 mc.	Part of C2
C2C	Condenser, aerial trimmer, 15.2 mc.	Part of C2
C2D	Condenser, aerial trimmer, 7.5 mc.	Part of C2
C2E	Condenser, aerial trimmer, SW2	Part of C2
C3	Condenser, d-c blocking, 100 μ f.	62-110009001*
C4	Condenser, tracking, BS1, 485 μ f.	30-1220-23
C5	Condenser, shunt, BS3, 62 μ f.	30-1220-62
C6	Condenser, shunt, BS2, 131 μ f.	30-1220-38
C7	Condenser, trimmer, 9-section	31-6507-4
C7A	Condenser, r-f trimmer, 21.5 mc.	Part of C7
C7B	Condenser, r-f trimmer, 17.8 mc.	Part of C7
C7C	Condenser, r-f trimmer, 15.2 mc.	Part of C7
C7D	Condenser, r-f trimmer, 7.5 mc.	Part of C7
C7E	Condenser, r-f trimmer, SW2	Part of C7
C7F	Condenser, oscillator trimmer, 15.2 mc.	Part of C7
C7G	Condenser, oscillator trimmer, 11.7 mc.	Part of C7
C7H	Condenser, oscillator trimmer, 9.7 mc.	Part of C7
C7I	Condenser, oscillator trimmer, SW2	Part of C7
C8	Condenser, bias filter, 220 μ f.	62-122001001
C9	Condenser, d-c blocking, 220 μ f.	62-122001001*
C10	Condenser, tracking, BS1, 485 μ f.	30-1220-23
C11	Condenser, shunt, BS3, 62 μ f.	30-1220-62
C12	Condenser, shunt, BS2, 131 μ f.	30-1220-38
C13	Condenser, oscillator trimmer, BC	31-6308
C14	Condenser, trimmer, 3-section	31-6477-4
C14A	Condenser, oscillator padder, BC	Part of C14
C14B	Condenser, oscillator trimmer, SW1	Part of C14
C14C	Condenser, oscillator trimmer, 7.5 mc.	Part of C14
C15	Condenser, d-c blocking, 100 μ f.	62-110009001*
C16	Condenser, fixed tracker, SW1, 3600 μ f.	60-20365314
C17	Condenser, bias filter, 25 μ f.	30-4588
C18	Condenser, oscillator divider, BS1, 180 μ f.	30-1220-30*
C19	Condenser, oscillator divider, BS2, 330 μ f.	60-10335317
C20	Condenser, oscillator divider, BS3, 82 μ f.	60-00825237
C21	Condenser, tracking, BS1, 540 μ f.	30-1220-61
C22	Condenser, d-c blocking, 270 μ f.	60-10275417
C23	Condenser, a-v-c filter, .047 μ f.	45-3505-28
C24	Condenser, trimmer, 2-section	31-6476-19
C24A	Condenser, oscillator trimmer, 21.5 mc.	Part of C24
C24B	Condenser, oscillator trimmer, 17.8 mc.	Part of C24
C25	Condenser, d-c blocking, 100 μ f.	60-10105417
C26	Condenser, shunt, SW1, 3.3 μ f.	30-1221
C27	Condenser, primary trimmer, 2nd i-f	Part of Z2
C28	Condenser, secondary trimmer, 2nd i-f	Part of Z2
C29	Condenser, primary trimmer, 1st i-f	Part of Z1
C30	Condenser, secondary trimmer, 1st i-f	Part of Z1
C31	Condenser, i-f filter, 100 μ f. (part of Z2)	Part of Z2
C32	Condenser, i-f filter, 100 μ f. (part of Z2)	Part of Z2
C33	Condenser, line filter, .01 μ f.	45-3505-92*
C34	Condenser, a-v-c filter, .047 μ f.	45-3505-28*
C35	Condenser, line filter, .01 μ f.	45-3505-92*
C36	Condenser, diode coupling, 100 μ f.	62-110009001*
C37	Condenser, diode coupling, 100 μ f.	62-110009001*
C38	Condenser, d-c blocking, .006 μ f.	30-4591
C39	Condenser, d-c blocking, .006 μ f.	30-4591
C40	Condenser, coupling, .003 μ f.	30-4639
C41	Condenser, d-c blocking, .01 μ f.	30-1238-6
C42	Condenser, d-c blocking, .05 μ f.	30-4519
C43	Condenser, d-c blocking, .047 μ f.	45-3505-28*
C44	Condenser, bass compensation, .006 μ f.	30-4591
C45	Condenser, tone compensation, high-cut, .01 μ f.	30-4572
C46	Condenser, d-c blocking, .006 μ f.	30-4591
C47	Condenser, plate by-pass, 220 μ f.	62-122001001
C48	Condenser, electrolytic, 3-section	30-2570-15
C48A	Condenser, filter, 20 μ f., 450v	Part of C48
C48B	Condenser, filter, 10 μ f., 450v	Part of C48
C48C	Condenser, filter, 10 μ f., 450v	Part of C48
C49	Condenser, grid return, .001 μ f.	30-4620
C50	Condenser, plate by-pass, .0015 μ f.	30-4616
C51	Condenser, electrolytic, 3-section	30-2570-15
C51A	Condenser, filter, 10 μ f., 450v	Part of C51
C51B	Condenser, filter, 20 μ f., 450v	Part of C51
C51C	Condenser, filter, 10 μ f., 450v	Part of C51
C52	Condenser, screen by-pass, .05 μ f.	30-4638
C53	Condenser, screen by-pass, .05 μ f.	30-4638
I1	Pilot lamp, 6.3v	34-2064
J1	Socket, phono input	27-6126
J2	Socket, phono power	27-6200
LS1	Speaker, p-m, 10-inch	36-1610-17
R1	Resistor, grid return, 470,000 ohms	66-4478340*
R2	Resistor, grid return, 470,000 ohms	66-4478340*
R3	Resistor, voltage divider, 120,000 ohms	66-4128340
R4	Resistor, loading, 4700 ohms	66-2478340*
R5	Resistor, plate load, 22,000 ohms, 2 watts	66-3225340*
R6	Resistor, a-v-c divider, 1.8 megohms	66-5188340*
R7	Resistor, a-v-c filter, 1.5 megohms	66-5158340*
R8	Resistor, cathode bias, 22,000 ohms	66-3228340*
R9	Resistor, grid return, 47,000 ohms	66-3478340*
R10	Resistor, parasitic suppressor, 68 ohms	66-0688350*

Reference Symbol	Description	Service Part No.
R11	Resistor, plate load, 22,000 ohms, 1 watt	66-3224340*
R12	Resistor, grid return, 470,000 ohms	66-4478340*
R13	Resistor, filter, 330 ohms, 3 watts	33-1334-8
R14	Resistor, a-v-c delay, 3.3 megohms	66-5338340*
R15	Resistor, filter, 470 ohms, 1 watt	66-1474540*
R16	Resistor, a-v-c load, 2.2 megohms	66-5228340*
R17	Resistor, cathode bias, 1000 ohms	66-2108340*
R18	Resistor, bias divider, 150,000 ohms	66-4158340*
R19	Resistor, a-v-c filter, 2.2 megohms	66-5228340*
R20	Resistor, a-v-c filter, 2.2 megohms	66-5228340*
R21	Resistor, i-f filter, 47,000 ohms (part of Z2)	66-3478340*
R22	Resistor, phono peramplifier plate, 56,000 ohms	66-3565340*
R23	Resistor, grid return, 470,000 ohms	66-4478340*
R24	Resistor, inverse feedback, 150 ohms	66-1158350*
R25	Resistor, volume control, 2 megohms	33-5535-34
R26	Resistor, bass compensation, 68,000 ohms	66-3688540*
R27	Resistor, tone control, 5 megohms	33-5566-38
R28	Resistor, grid return, 10 megohms	66-6108340*
R29	Resistor, cathode degeneration, 4.7 ohms	66-9478340*
R30	Resistor, filter, 1000 ohms, 1 watt	66-2104540*
R31	Resistor, filter, 22,000 ohms, 2 watts	66-3224540*
R32	Resistor, plate load, 270,000 ohms	66-4228340*
R33	Resistor, cathode load, 22,000 ohms	66-3228340*
R34	Resistor, bias voltage divider, 330 ohms, 3 watts	33-1334-8
R35	Resistor, load, 3.3 megohms	66-5338340
R36	Resistor, plate load, 22,000 ohms	66-3228340*
R37	Resistor, cathode bias, 2200 ohms	66-2228340*
R38	Resistor, diode load, 330,000 ohms	66-4338340*
R39	Resistor, grid return, 470,000 ohms	66-4478340*
R40	Resistor, bias, 100,000 ohms	66-4108340*
R41	Resistor, screen dropping, 220,000 ohms	66-4228340
R42	Resistor, plate filter, 470 ohms	66-1478340
S1	Switch, off-on	Part of R27
T1	Transformer, power	32-8584
T2	Transformer, output	32-8585
T3	Transformer, BC aerial	32-4033-15
T4	Transformer, SW1 and BS1 aerial	32-4364
T5	Transformer, SW2 aerial	32-4208
T6	Transformer, BS2, BS3, BS4, BS5, and BS6 aerial	32-3670
T7	Transformer, BC r-f	32-4369
T8	Transformer, SW1 and BS1 r-f	32-4364-1
T9	Transformer, SW2 r-f	32-4208-7
T10	Transformer, BS2, BS3, BS4, BS5, and BS6 r-f	32-3671
T11	Transformer, BC oscillator	32-4370-2
T12	Transformer, SW1 and BS1 oscillator	32-4207-2
T13	Transformer, SW2 oscillator	32-4208-2
T14	Transformer, BS2, BS3, BS4, BS5, and BS6 oscillator	32-4212-2
TB1	Terminal board, aerial connection	38-9870
TC1	Tuning core assembly, 3-section	76-5958
TC1A	Tuning core, band spread, aerial	Part of TC1
TC1B	Tuning core, band spread, r-f	Part of TC1
TC1C	Tuning core, band spread, osc.	Part of TC1
TC2	Tuning core, SW2 aerial	Part of T5
TC3	Tuning core, SW2 r-f	Part of T9
TC4	Tuning core, SW2 osc.	Part of T13
W1	Line cord	41-3821
WS1	Wafer switch, band-change	42-1883-2
WS2	Wafer switch, radio-phon	42-1971
Z1	Transformer, 1st i-f	32-3976
Z2	Transformer, 2nd i-f	32-4346-1

MISCELLANEOUS

Description	Service Part No.
Cabinet	10898
Back assembly	76-7502-1
Baffle assembly (part of cabinet)	40-8774
Cable, speaker	41-3714-2
Cord, drive (25-ft. spool)	45-8750
Dial-plate assembly	76-7333
Dial-scale assembly	76-4437
Painter	56-6495FCP
Spring, indicator (2)	56-3066FA38
Spring, indicator (part of 76-5616)	56-2155
Drive-shaft-and-bearing assembly	Part of WS1
Drum assembly (band indicator)	76-1246-2FA33
Knob, phono-radio	54-4774-11
Knob, band-selector	54-4774-12
Knob, tone, on-off	54-4774-13
Knob, tuning	54-4774
Knob, volume	54-4774-14
Loop, BC aerial	76-7493
Pilot-lamp assembly	76-1236-1
Pilot-lamp-carriage-and-spring assembly	76-5616
Shield, tube	56-2731
Socket, Loktal (6)	27-6207
Socket, 9-pin miniature	27-6203-18
Socket, 7-pin miniature	27-6275
Whip aerial	76-7503
Lead assembly, aerial	76-7504

MODELS 53-950,
53-952, 53-954

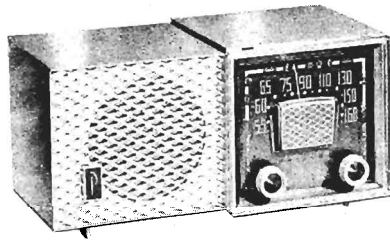

MODEL 53-950

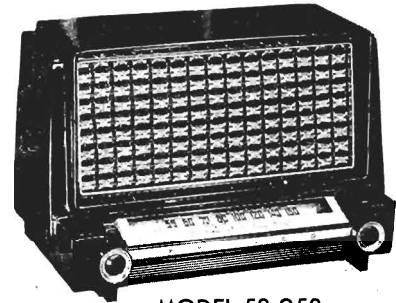

MODEL 53-952

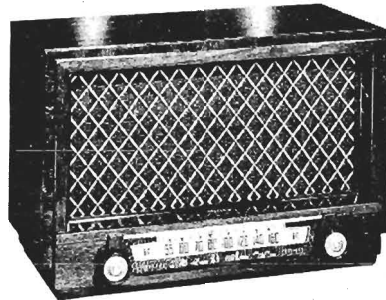

MODEL 53-954

SPECIFICATIONS

Cabinet	
Model 53-950	Phenolic, brown or ivory
Model 53-952	Phenolic, brown
Model 53-954	Wood, mahogany or blond
Circuit	Five-tube superheterodyne (plus rectifier)
Frequency Range	
Broadcast	540—1620 kc.
Special Services	1700—3400 kc.
Audio Output	1 watt
Operating Voltage	105—120 volts, a.c. or d.c.
Power Consumption	30 watts
Antenna	Built-in, high-impedance loop
Intermediate Frequency	455 kc.
Philco Tubes	6BJ6 r-f ampl.; 12BE6 converter; 6BJ6 i-f ampl.; 6AQ6 det., a.v.c., 1st audio; 35C5 output; 35W4 rectifier

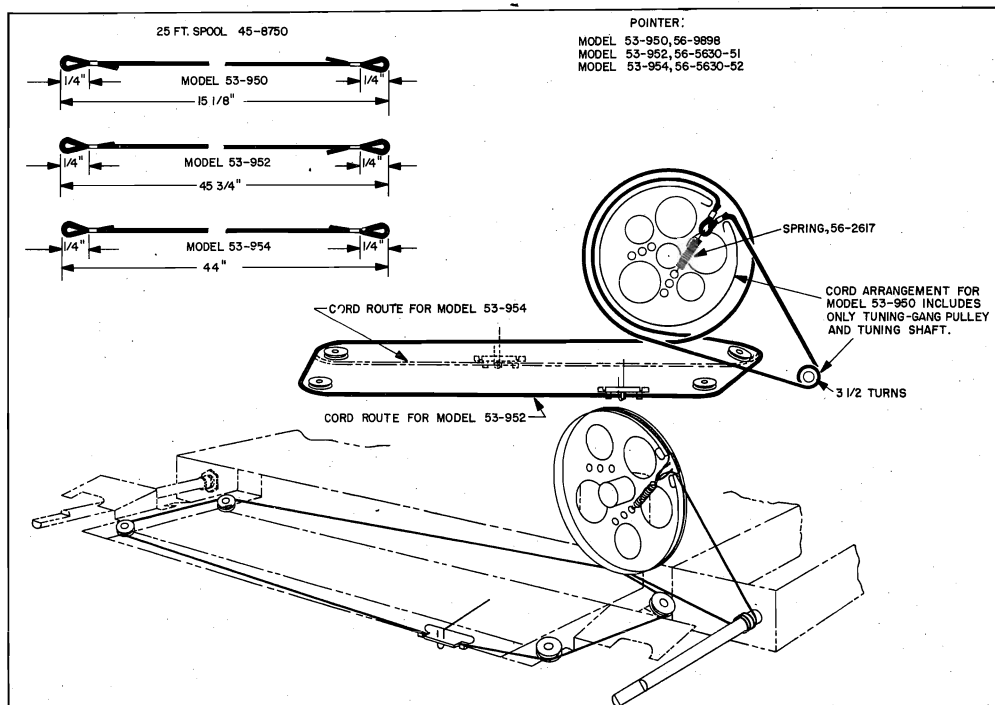

Figure 1. Drive-Cord Installation Details

TP2-2656

PR-2419

ALIGNMENT PROCEDURE

GENERAL

RADIO CONTROLS—Set volume control for maximum output and tuning control as given in the alignment chart. Set band switch to broadcast position for first 5 steps, and to special services position for steps 6 and 7.

OUTPUT INDICATOR—Connect output indicator (either on oscilloscope or a 1000-ohms-per-volt, a-c voltmeter) across voice-coil terminals.

SIGNAL GENERATOR—Use an AM r-f generator, connected as indicated in the alignment chart.

OUTPUT LEVEL—During alignment, attenuate signal-generator output to maintain output indication below 1 volt.

DIAL POINTER—Before the alignment is started, the dial pointer should be set to coincide with the dial scale mark to the left of "55" when the tuning gang is fully meshed.

ALIGNMENT CHART

STEP	SIGNAL GENERATOR		RADIO		ADJUST
	CONNECTION TO RADIO	DIAL SETTING	DIAL SETTING	SPECIAL INSTRUCTIONS	
1	Ground lead to B—. Output lead through a .01- μ f. condenser to pin 7 (mixer grid) of 12BE6, converter.	455 kc.	Tuning gang fully open.	Adjust, in order given in next column, for maximum output.	TC5—2nd i-f sec. TC4—2nd i-f pri. TC3—1st i-f sec. TC2—1st i-f pri.
2	Radiating loop. See Note 1 below.	1620 kc.	1620 kc. See Note 2 below.	Adjust for maximum output.	CLC—osc. trimmer
3	Same as step 2.	1520 kc.	Tune radio to generator signal.	Adjust for maximum output. (High-frequency adjustment)	CLB—mixer-grid trimmer CIA—r-f trimmer
4	Same as step 2.	580 kc.	Same as step 3.	Adjust for maximum output. (Low-frequency adjustment)	TC1—r-f transformer
5	Repeat steps 3 and 4 until no further improvement is obtained.				
6	Same as step 2.	3200 kc.	Same as step 3.	Adjust for maximum output.	C5—special-services mixer-grid trimmer C2—special-services r-f trimmer
7	Same as step 2.	1800 kc.	Same as step 3.	Adjust for maximum output.	C3—special-services r-f padder

NOTE 1: Make up a 6-8 turn, 6-inch-diameter loop from insulated wire; connect to signal-generator leads and place near radio loop antenna. The loop antenna must be connected to the radio.

NOTE 2: To set the tuning gang to 1620 kc., place a piece of 6-mil flat shim stock beneath the heel of the rotor, and turn the rotor until it holds the shim firmly in place. Then remove the shim.

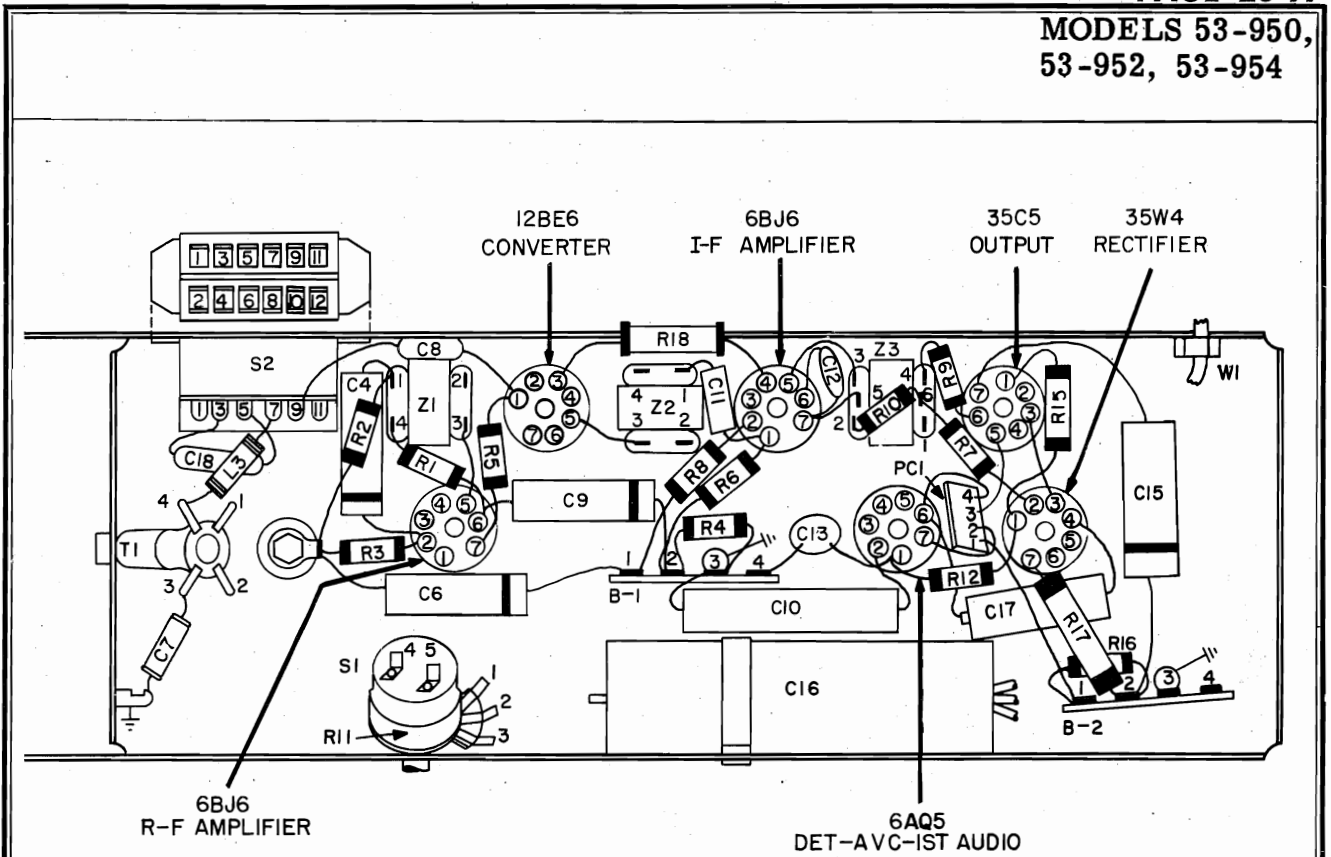

Figure 2. Top View, Showing Tuning Adjustments

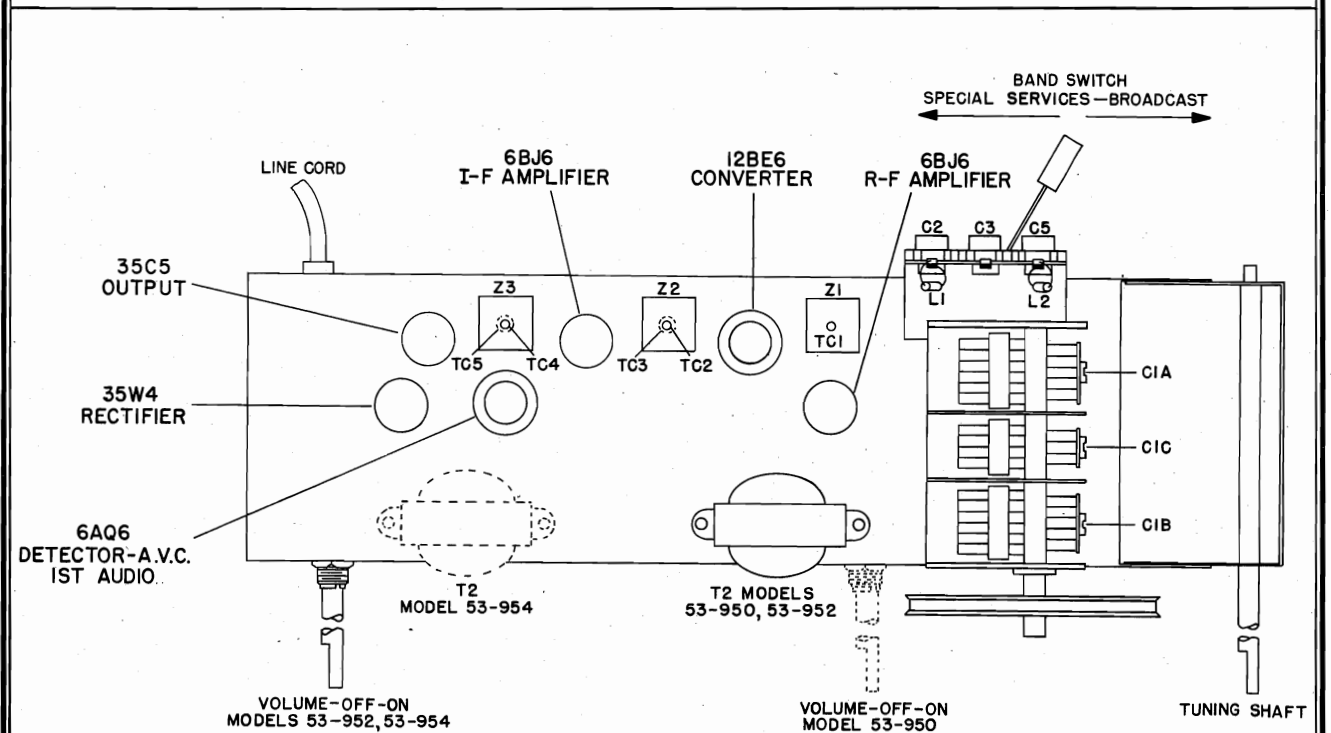

Figure 3. Base View, Model 53-950, Showing Parts Placement

MODELS 53-950,
53-952, 53-954

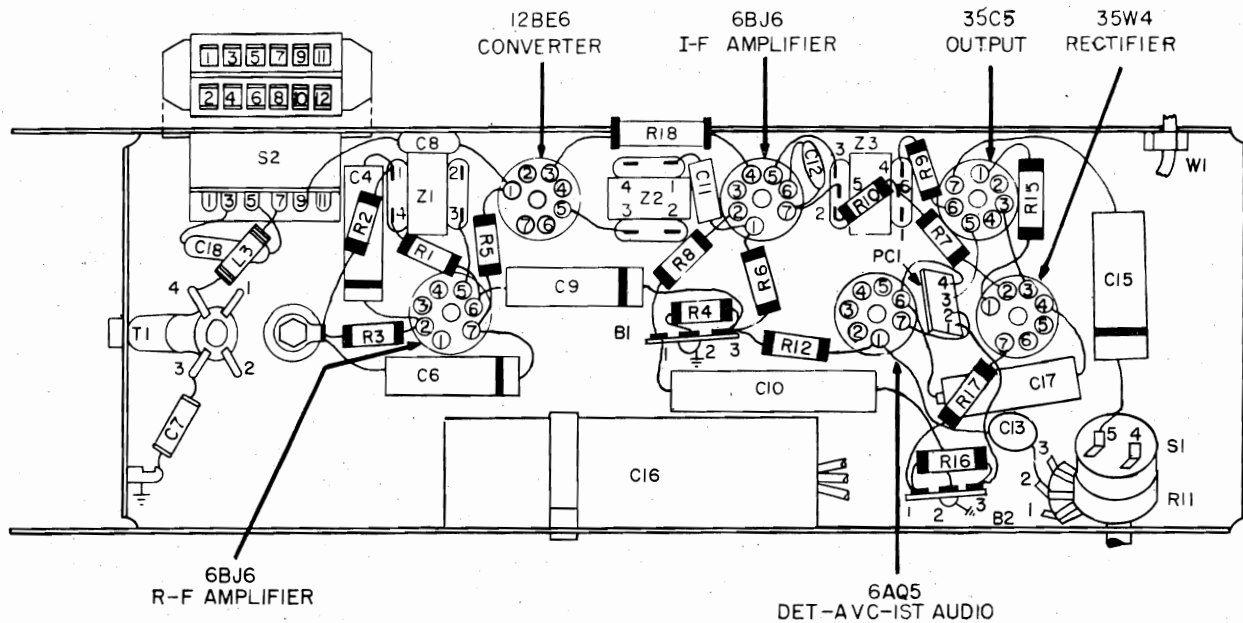

Figure 4. Base View, Models 53-952 and 53-954, Showing Parts Placement

TP2-265

PARTS LIST

NOTE: Part numbers identified by an asterisk (*) are general replacement items. These numbers may not be identical with those on factory parts. Also, the electrical values of some replacement items may differ from the values indicated in the schematic diagram and parts list. The values substituted in any case are so chosen that the operation will be either unchanged or improved. When ordering replacements, use only the "Service Part No."

Reference Symbol	Description	Service Part No.	Reference Symbol	Description	Service Part No.
C1	Condenser, tuning gang, 3 section Model 53-95031-2771 Models 53-952, 53-95431-2771-1		C13	Condenser, audio coupling, .005 μ f.30-1238-1*	
C1A	Condenser, trimmer, antennaPart of C1		C14	Condenser, d-c blocking, .005 μ f.Part of PC1	
C1B	Condenser, trimmer, r-fPart of C1		C15	Condenser, tone compensation, .022 μ f.30-4650-43*	
C1C	Condenser, trimmer, oscillatorPart of C1		C16	Condenser, electrolytic filter30-2575-27	
C2	Condenser, trimmer, special services r-fPart of CA1		C16A	Condenser, filter, 30 μ f., 150vPart of C16	
C3	Condenser, padder, special services r-fPart of CA1		C16B	Condenser, filter, 30 μ f., 150vPart of C16	
C4	Condenser, r-f by-pass, .05 μ f.30-4650-45*		C16C	Condenser, filter, 40 μ f., 150vPart of C16	
C5	Condenser, trimmer, special services mixer-gridPart of CA1		C17	Condenser, line by-pass, .047 μ f.30-4650-45*	
C6	Condenser, a-v-c by-pass, .05 μ f.30-4650-45*		C18	Condenser, fixed padder, 865 μ f.30-1220-68	
C7	Condenser, fixed trimmer, 7.5 μ f.30-1224-65		CA1	Condenser assembly, trimmer31-6477-17	
C8	Condenser, d-c blocking, 47 μ f.60-00475420		II	Lamp, pilot34-2068	
C9	Condenser, screen by-pass, .05 μ f.30-4650-45*		L1	Coil, special services r-f32-4561-4	
C10	Condenser, special, B- to chassis, .2 μ f.30-4644		L2	Coil, special services mixer-grid32-4561-4	
C11	Condenser, i-f coupling, 220 μ f.62-122001001*		L3	Coil, oscillator shunt32-4562-1	
C12	Condenser, screen by-pass, .002 μ f.30-1238-8*		PC1	Printed circuit30-6001	
			R1	Resistor, screen dropping, 10,000 ohms66-3108340*	
			R2	Resistor, a-v-c load, 4.7 megohms66-5478340*	
			R3	Resistor, a-v-c load, 2.2 megohms66-5228340*	
			R4	Resistor, B- to chassis, 150,000 ohms66-4158340*	

PARTS LIST (Continued)

Reference Symbol	Description	Service Part No.	Description	Service Part No.
R5	Resistor, grid leak, 22,000 ohms	66-3228340*	Socket, tube (2)	27-6203-14
R6	Resistor, grid leak, 2.2 megohms	66-5228340*	Socket, tube (4)	27-6265
R7	Resistor, a-v-c load, 2.2 megohms	66-5228340*	Speed nut (4)	1W56920FE7
R8	Resistor, cathode bias, 180 ohms	66-1188340*	MODEL 53-950	
R9	Resistor, screen dropping, 2200 ohms	66-2228340*	Cabinet, mahogany	10938
R10	Resistor, i-f filter, 47,000 ohms	66-3478340*	Cabinet, ivory	10938-2
R11	Volume control, 500,000 ohms Models 53-950, 53-954	33-5566-43	Cabinet back and loop assembly	76-7881
	Model 53-952	33-5566-46	Scale, mahogany	54-5152
R12	Resistor, grid leak, 10 megohms	66-6108340*	Scale, ivory	54-5152-1
R13	Resistor, plate load, 500,000 ohms	Part of PC1	Knob (2)	54-4718-39
R14	Resistor, grid leak, 500,000 ohms	Part of PC1	Knob, band switch	54-4998
R15	Resistor, cathode bias, 150 ohms, 1 watt	66-1154340*	Pointer	56-9898
R16	Resistor, B+ filter, 1200 ohms	66-2128340*	Shaft, tuning	56-9807-1
R17	Resistor, B+ filter, 220 ohms, 1 watt	66-1224340*	Spring, retaining	28-8610
R18	Resistor, tube saver, 100 ohms	33-1343-3	Speaker	45-9731
S1	Switch, off-on	Part of R11	MODEL 53-952	
S2	Switch, broadcast-special services Model 53-950	42-1893-3	Cabinet	10963
	Model 53-952	42-1893-5	Cabinet back and loop assembly	76-8068
	Model 53-954	42-1893-4	Knob (2)	54-6025
T1	Transformer, oscillator	32-4453-2	Knob, band switch	54-4998
T2	Transformer, output	32-8310-3	Panel, diffusing	54-8819
W1	Line cord	L-2183*	Clip, panel diffusing	56-3587-1
Z1	Transformer, r-f	32-4399-7A	Pointer	56-5630-51
Z2	Transformer, 1st i-f	32-4160A	Pointer rail assembly	76-8067
Z3	Transformer, 2nd i-f	32-4240A	Scale, dial	54-5163
MISCELLANEOUS			Shaft, tuning	56-9807-2
PARTS COMMON TO ALL MODELS			Spring, retaining	28-8610
Description		Service Part No.	Speaker	45-9736
Drive cord, 25-ft. spool		45-8750*	MODEL 53-954	
Spring, drive cord		56-2617	Cabinet, mahogany	10959
Rubber mount, gang mtg. (3)		27-4596	Cabinet, blond	10959-1
Shield, tube (2)		56-5629FA3	Back assembly, mahogany cabinet	76-8063
Socket assembly, pilot lamp		27-6233-6	Back assembly, blond cabinet	76-8063-10
			Loop assembly, antenna	76-2127-13
			Metal grille	56-10034
			Knob (2), mahogany	54-6019
			Knob (2), blond	54-6019-1
			Knob, band switch	54-4998
			Panel, diffusing	54-8817
			Clip, diffusing panel	56-3587-1
			Pointer	56-5630-52
			Pointer rail assembly	76-7981
			Shaft, tuning	56-9807-1
			Spring, retaining	28-8610
			Speaker	36-1626-5

MODELS 53-950,
53-952, 53-954

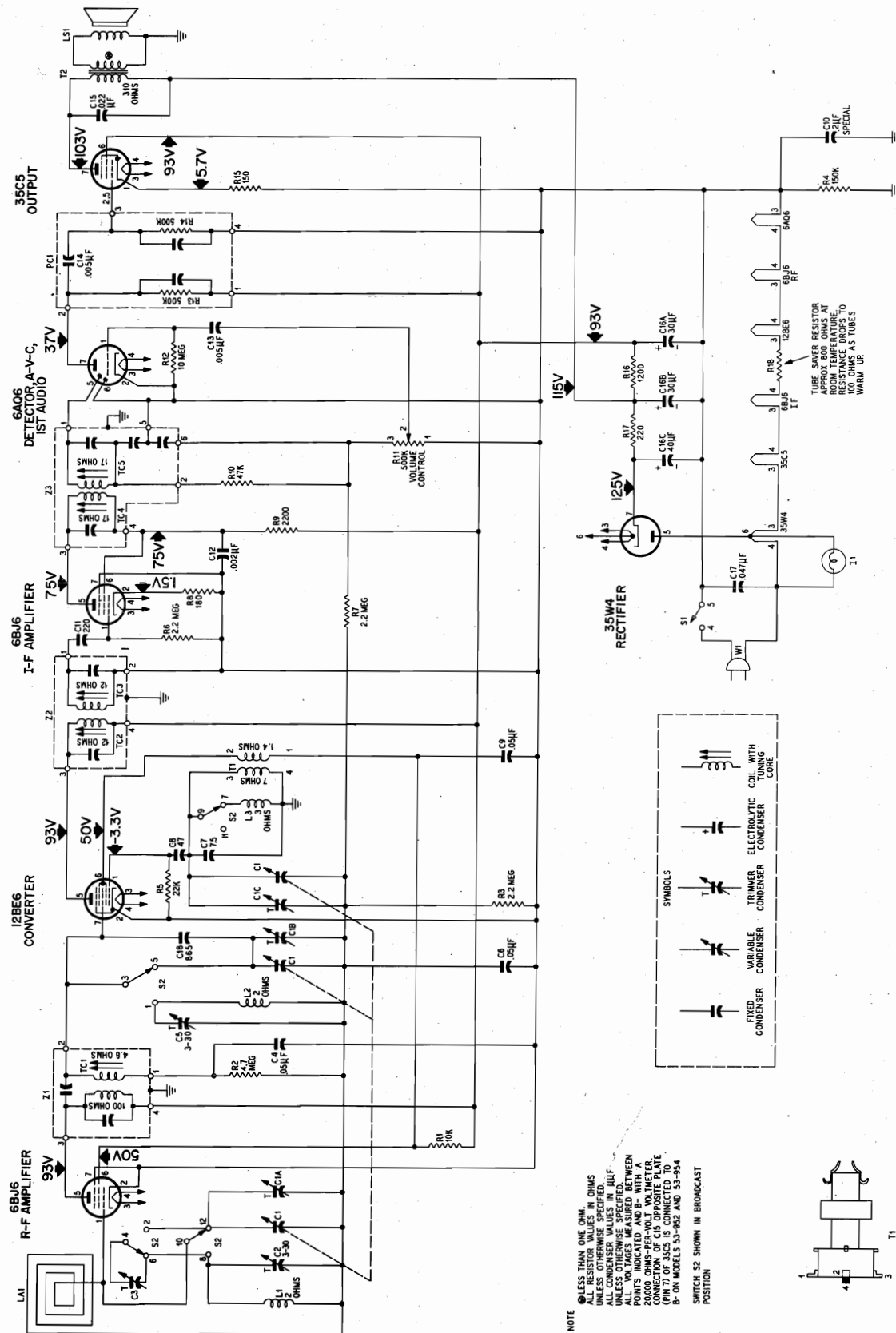
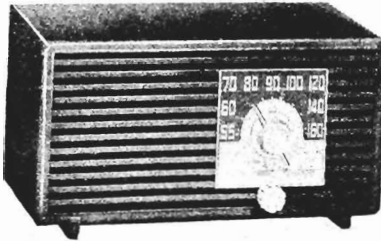

Figure 5. Philco Radio Models 53-950, 53-952, and 53-954, Schematic Diagram



TP2-3229

MODEL 53-559

SPECIFICATIONS

CABINET	Molded plastic
CIRCUIT	Four-tube superheterodyne (plus rectifier)
FREQUENCY RANGE	
Standard Broadcast	540—1620 kc.
Special Services	1700—3400 kc.
AUDIO OUTPUT	1 watt
OPERATING VOLTAGE	105—120 volts, a.c. or d.c.
POWER CONSUMPTION	30 watts
ANTENNA	High-impedance loop
INTERMEDIATE FREQUENCY	455 kc.
PHILCO TUBES	12BE6, converter; 12BA6, i-f amplifier; 12AV6, detector-a.v.c.-1st audio; 35C5, output; 35W4, rectifier

NOTE: The antenna is mounted on the cabinet back. When removing the cabinet back, use care to avoid breaking the antenna leads.

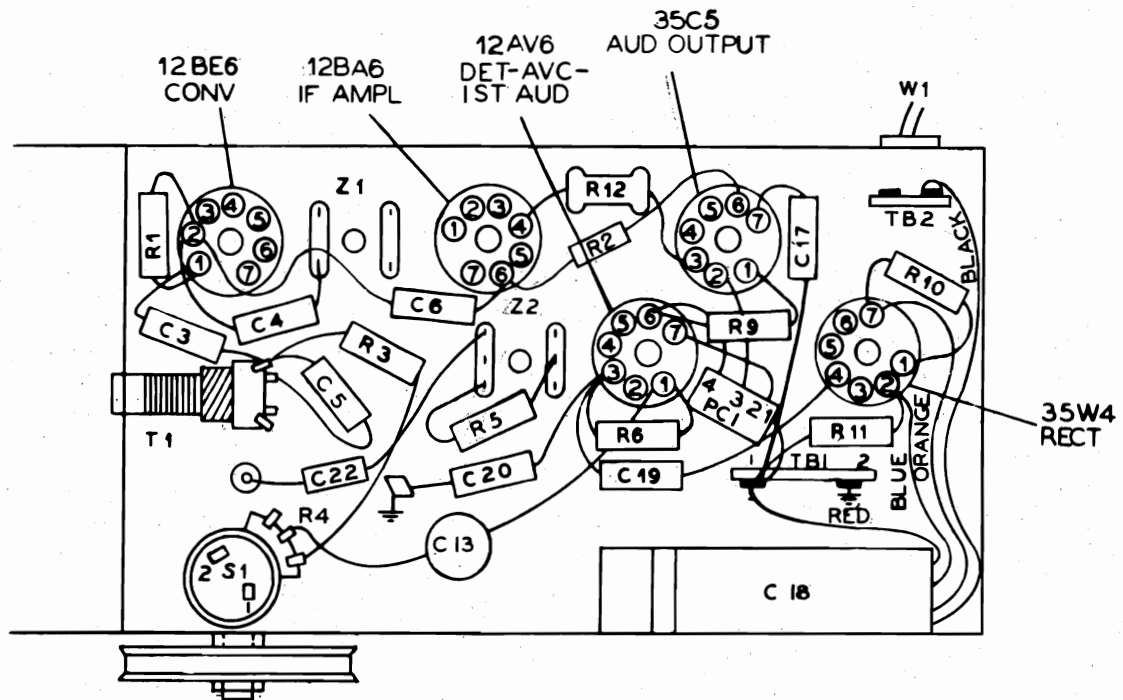

Figure 1. Base View, Showing Parts Placement

TP2-3228

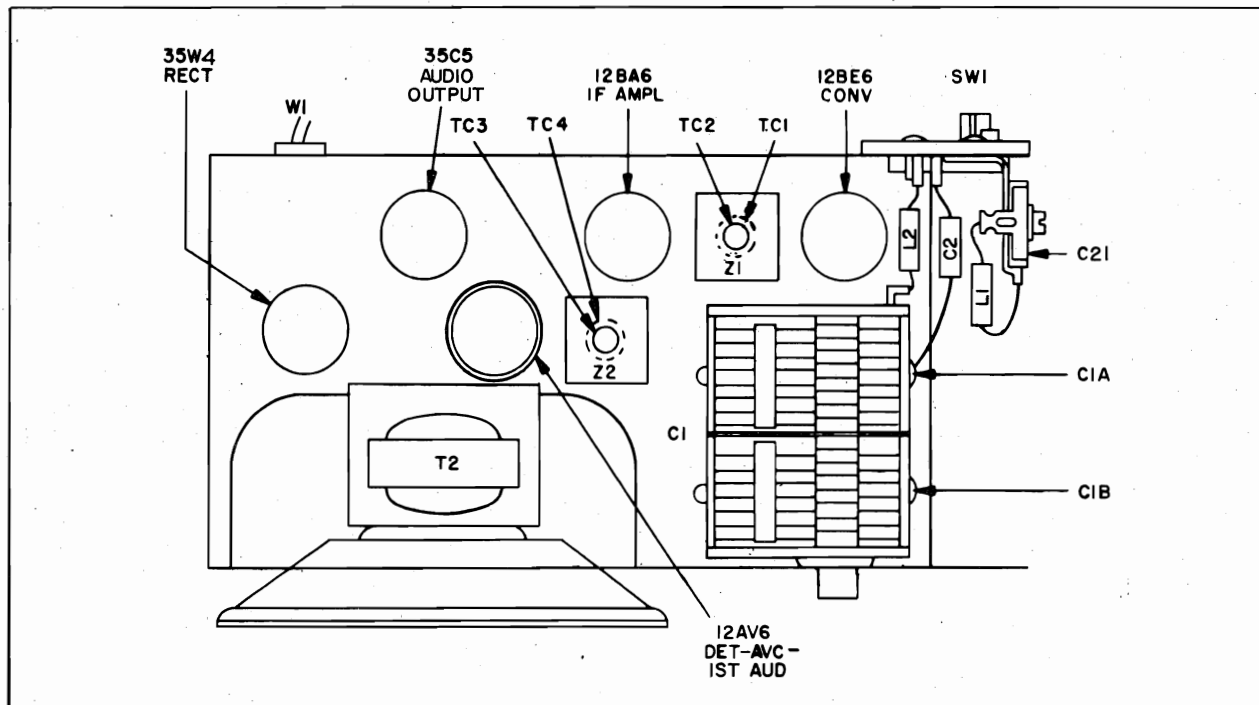

Figure 2. Top View, Showing Tuning Adjustments

TP2-3227

ALIGNMENT PROCEDURE

RADIO CONTROLS—Set volume control to maximum. Set tuning control and band switch as indicated in chart.

SIGNAL GENERATOR—Connect generator and set frequency as indicated in chart. Use modulated output.

OUTPUT METER—Connect across voice-coil terminals.

OUTPUT LEVEL—During alignment, adjust signal-generator output to hold output-meter reading below 1.25 volts.

ALIGNMENT CHART

STEP	SIGNAL GENERATOR		RADIO			ADJUST
	CONNECTION TO RADIO	DIAL SETTING	DIAL SETTING	BAND-SWITCH SETTING	SPECIAL INSTRUCTIONS	
1	Ground-lead to B-; output lead through a .1- μ f. condenser to grid (pin 7) of 12BE6.	455 kc.	Tuning gang fully open	Broadcast	Adjust tuning cores, in order given, for maximum output. (TC1 and TC3 are located at top of transformers.)	TC4—2nd i-f sec. TC3—2nd i-f pri. TC2—1st i-f sec. TC1—1st i-f pri.
2	Radiating loop (see note below).	1620 kc.	1620 kc.*	Broadcast	Adjust trimmer for maximum output.	C1B—osc.
3	Same as step 2.	1500 kc.	1500 kc.†	Broadcast	Adjust trimmer for maximum output.	C1A—antenna (broadcast)
4	Same as step 2.	3200 kc.	3200 kc.†	Special services	Adjust trimmer for maximum output.	C21—antenna (special services)

NOTE: Make up a 6–8 turn, 6-inch-diameter loop from insulated wire; connect to signal-generator leads, and place about 1 foot from radio loop. The position of the radio loop, with respect to the chassis, should be approximately the same as when both are mounted in the cabinet.

* To set the tuning gang to 1620 kc., fully open the tuning gang and insert a .006-inch nonmetallic shim between the heel of the rotor and the top of the stator plates. Close the tuning gang sufficiently to hold the shim in place, and then remove the shim without disturbing the gang setting.

† To set the radio to this frequency, place chassis in cabinet, attach knob, and tune until pointer indicates the correct frequency. Then remove knob and take chassis from cabinet without disturbing the setting of the gang.

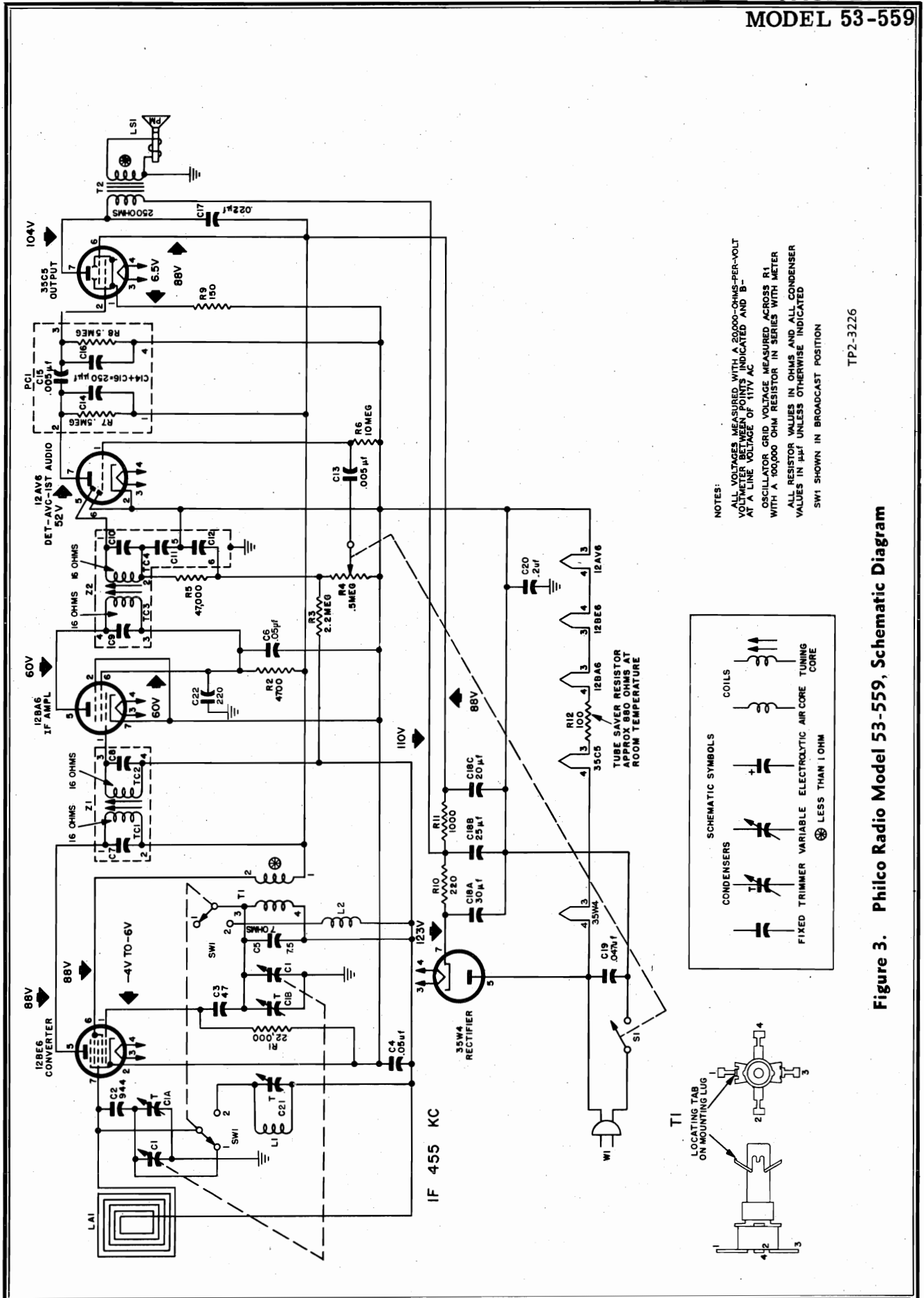

TP2-3226

Figure 3. Philco Radio Model 53-559, Schematic Diagram

PARTS LIST

NOTE: Part numbers identified by an asterisk (*) are general replacement items. These numbers may not be identical with those on factory parts. Also, the electrical values of some replacement items may differ from the values indicated in the schematic diagram and parts list. The values substituted in any case are so chosen that the operation will be either unchanged or improved. When ordering replacements, use only the "Service Part No."

Reference Symbol	Description	Service Part No.
C1	Condenser, tuning gang	31-2751-13
C1A	Condenser, r-f trimmer	Part of C1
C1B	Condenser, oscillator trimmer	Part of C1
C2	Condenser, antenna series tracker, 944 $\mu\mu\text{f}$.	30-1220-65
C3	Condenser, oscillator grid, 47 $\mu\mu\text{f}$.	30-1230-4
C4	Condenser, α -v-c by-pass, .05 μf .	30-4650-45*
C5	Condenser, drift compensation, 7.5 $\mu\mu\text{f}$.	30-1224-83
C6	Condenser, screen by-pass, .05 μf .	30-4650-45*
C7	Condenser, i-f tuning	Part of Z1
C8	Condenser, i-f tuning	Part of Z1
C9	Condenser, i-f tuning	Part of Z2
C10	Condenser, i-f tuning	Part of Z2
C11	Condenser, detector filtering	Part of Z2
C12	Condenser, detector filtering	Part of Z2
C13	Condenser, audio coupling, .005 μf .	30-1238-1
C14	Condenser, plate by-pass	Part of PC1
C15	Condenser, audio coupling, .005 μf .	Part of PC1
C16	Condenser, compensating	Part of PC1
C17	Condenser, tone compensation, .022 μf .	30-4650-43
C18	Condenser, electrolytic, 3-section	30-2573
C18A	Condenser, filter, 30 μf ., 150v	Part of C18
C18B	Condenser, filter, 25 μf ., 150v	Part of C18
C18C	Condenser, filter, 20 μf ., 150v	Part of C18
C19	Condenser, line by-pass, .047 μf .	30-4650-45*
C20	Condenser, B- to chassis, .2 μf .	30-4650-49*
C21	Condenser, trimmer, special services	31-6473-29
C22	Condenser, r-f by-pass, 220 $\mu\mu\text{f}$.	60-10225417
L1	Coil, antenna, special services	32-4561-3
L2	Coil, oscillator shunt	32-4562-2
LA1	Loop	Part of cabinet back
LS1	Speaker, p-m	36-1627-8
PC1	Printed circuit	30-6001
R1	Resistor, oscillator grid, 22,000 ohms	66-3228340*
R2	Resistor, i-f screen dropping, 4700 ohms	66-2478340*
R3	Resistor, α -v-c filter, 2.2 megohms	66-5228340*
R4	Resistor, volume control, .5 megohm	33-5566-41
R5	Resistor, diode load, 47,000 ohms	66-3478340*
R6	Resistor, grid return, 10 megohms	66-6108340*
R7	Resistor, plate load, 500,000 ohms	Part of PC1
R8	Resistor, grid return, 500,000 ohms	Part of PC1
R9	Resistor, cathode bias, 150 ohms	66-1158340*
R10	Resistor, B plus filter, 220 ohms	66-1224340*
R11	Resistor, B plus filter, 1000 ohms	66-2108340*
R12	Resistor, tube saver, 100 ohms	33-1343-3
S1	Switch, off-on	Part of R4
SW1	Switch, broadcast-special services	42-1796-2
T1	Transformer, oscillator	32-4453-6
T2	Transformer, output	32-8384-2*
W1	Line cord	L-2183*
Z1	Transformer, 1st i-f	32-4161A
Z2	Transformer, 2nd i-f	32-4240A

MISCELLANEOUS

Description	Service Part No.
Back-and-loop ass'y.	76-7705-1
Cabinet	
Driftwood	10921-5
Mahogany	10921-6
Dial scale	28-9292
Drive cord (25-ft. spool)	45-8750*
Fastener, back	W2235FA9
Knob, tuning	54-4978-2
Knob, volume	54-4118
Shield, tube	56-5629FA3
Socket, tube (4)	27-6265*
Socket, tube (12AV6)	27-6203-14*

SPECIFICATIONS

CABINET	Plastic portable
CIRCUIT	Four-tube superheterodyne (plus selenium rectifier)
AUDIO OUTPUT	
A-C or d-c operation	150 milliwatts
Battery operation	90 milliwatts (75 milliwatts: battery-saver operation)
OPERATING VOLTAGE	
	117 volts, a.c. or d.c.
	1.5-volt "A" battery and 75-volt "B" battery
POWER CONSUMPTION	
A-C or d-c operation	11 watts
Battery operation	10 ma. from 75-volt "B" Battery (9 ma.: battery-saver operation)
	260 ma. from 1.5-volt "A" battery
ANTENNA	Magnecor high-impedance loop with provision for external antenna
INTERMEDIATE FREQUENCY	455 kc.
PHILCO TUBES	1R5 converter, 1U4 i-f amplifier, 1U5 detector-a.v.c. 1st audio, 3V4 output
BATTERY TYPE	P144 "B" battery P77 "A" battery

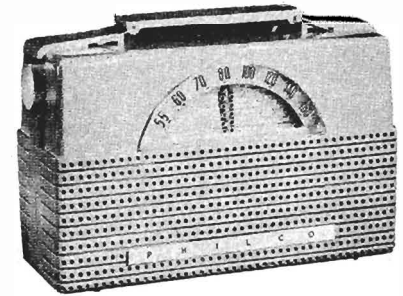

MODEL 53-652

TP2-3223

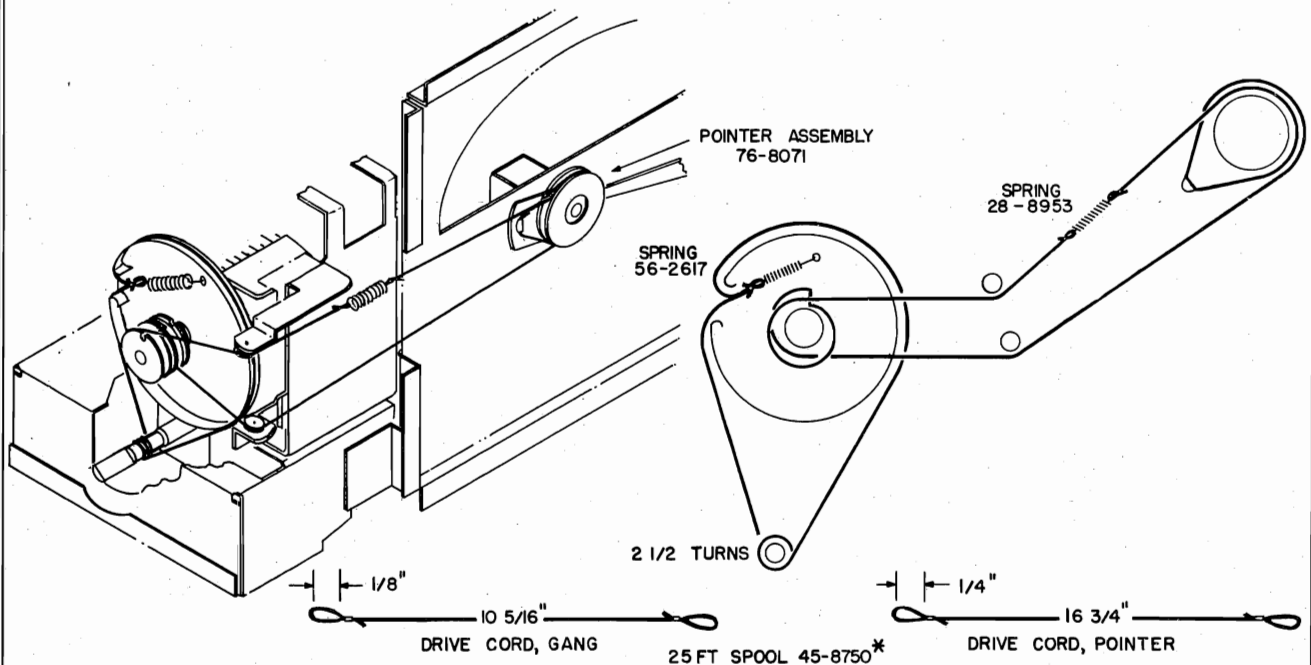

Figure 1. Dial-Cord Stringing Arrangement

TP2-3225

PR-2436

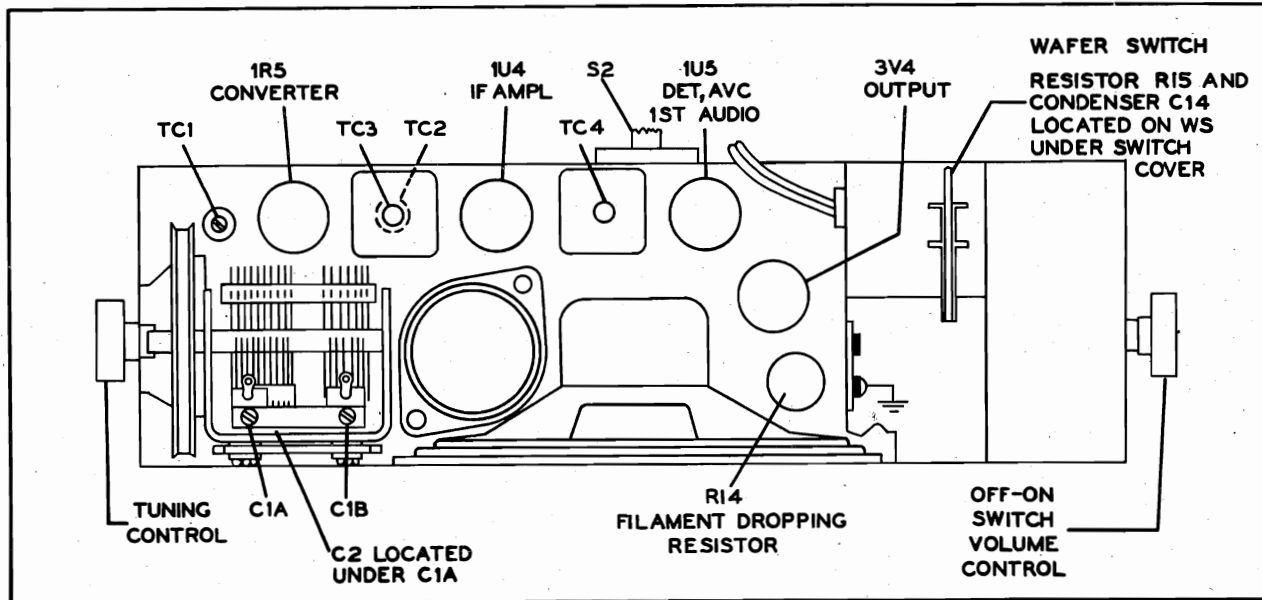

Figure 2. Top View, Showing Tuning Adjustments

TP2-3168

ALIGNMENT PROCEDURE

GENERAL—Allow the set and the test equipment to warm up for fifteen minutes before starting the alignment procedure.

DIAL POINTER—Before proceeding with the alignment, the dial pointer should be set to coincide with the index mark to the extreme left of the dial backplate when the tuning-condenser plates are fully meshed. See figure 4.

OUTPUT INDICATOR—Connect the output indicator (a 1000-ohm-per-volt, a-c voltmeter, or an oscilloscope) across the voice-coil terminals.

SIGNAL GENERATOR—Use an AM r-f signal gen-

erator. Connect the ground lead to B-, and connect the output lead as indicated in the alignment chart.

OUTPUT LEVEL—Attenuate the signal-generator output throughout the alignment so as to maintain the output level below .5 volt.

RADIO CONTROLS—Set the volume control to maximum. Set the tuning control as indicated in the alignment chart. During alignment of the radio, the batteries should be in the same position with respect to the chassis and the loop antenna as they normally are in the cabinet. It is recommended that a-c power be used when aligning the radio.

ALIGNMENT CHART

STEP	SIGNAL GENERATOR		RADIO		ADJUST
	CONNECTION TO RADIO	DIAL SETTING	DIAL SETTING	SPECIAL INSTRUCTIONS	
1	Connect signal generator through a .1- μ f. condenser to pin 6 (converter grid) of 1R5.	455 kc.	Tuning gang fully open.	Adjust for maximum output in order given.	TC4—2nd i-f sec. TC3—1st i-f sec. TC2—1st i-f pri.
2	Use radiating loop. (See NOTE 1 below.)	1620 kc.	1620 kc. (See NOTE 2 below.)	Adjust for maximum output.	C1B—osc. trimmer
3	Same as step 2.	1400 kc.	1400 kc. (See NOTE 2 below.)	Adjust for maximum output.	C1A—antenna trimmer
4	Same as step 2.	600 kc.	600 kc. (See NOTE 2 below.)	Adjust for maximum output. Rock tuning gang while making this adjustment.	TC1—osc. core
5	Repeat steps 2, 3, and 4 until no further improvement is obtained.				

NOTE 1. Use a 6-to-8-turn, 6-inch-diameter loop made up of insulated wire. Connect to generator terminals, and place about one foot from radio loop.

NOTE 2. The tuning condenser can be set to the proper frequency by turning it until the dial pointer coincides with the respective marks on the dial backplate. See figure 2.

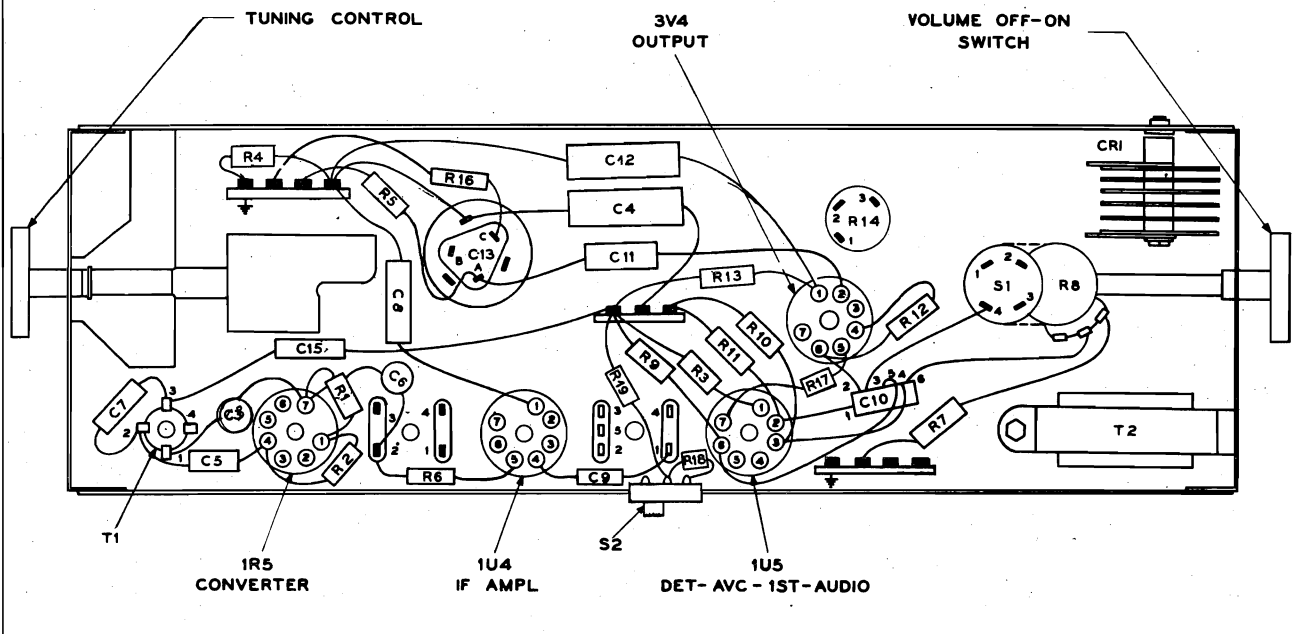

Figure 3. Base View, Showing Parts Placement

TP2-3167

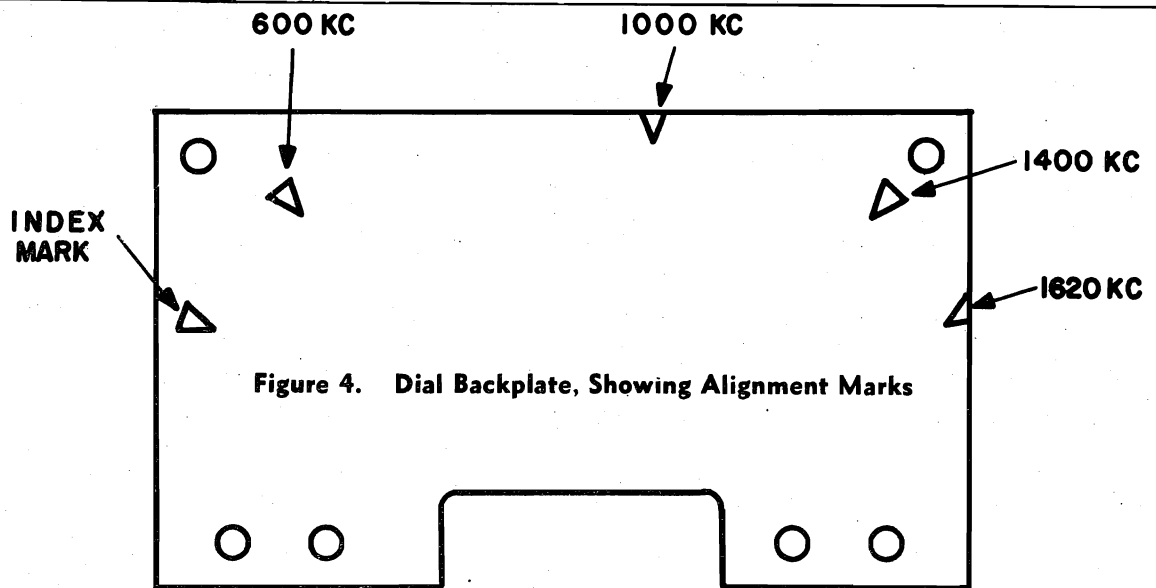
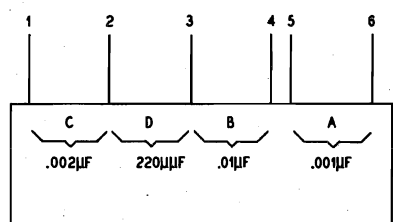
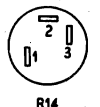
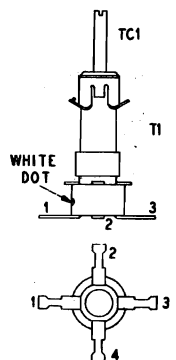

Figure 4. Dial Backplate, Showing Alignment Marks



* C10 FOUR SECTION CONDENSER

TUBE SOCKET VOLTAGES

B SUPPLY	1R5		1U4		1U5		3V4	
	RF PLATE PIN 2	OSC PLATE PIN 3	PLATE PIN 2	SCREEN PIN 3	PLATE PIN 2	SCREEN PIN 3	PLATE PIN 2	SCREEN PIN 3
PWR LINE (AC OR DC)	90	55	90	90	18	16	86	90
BATTERY	70	41	70	70	17	16	67	70

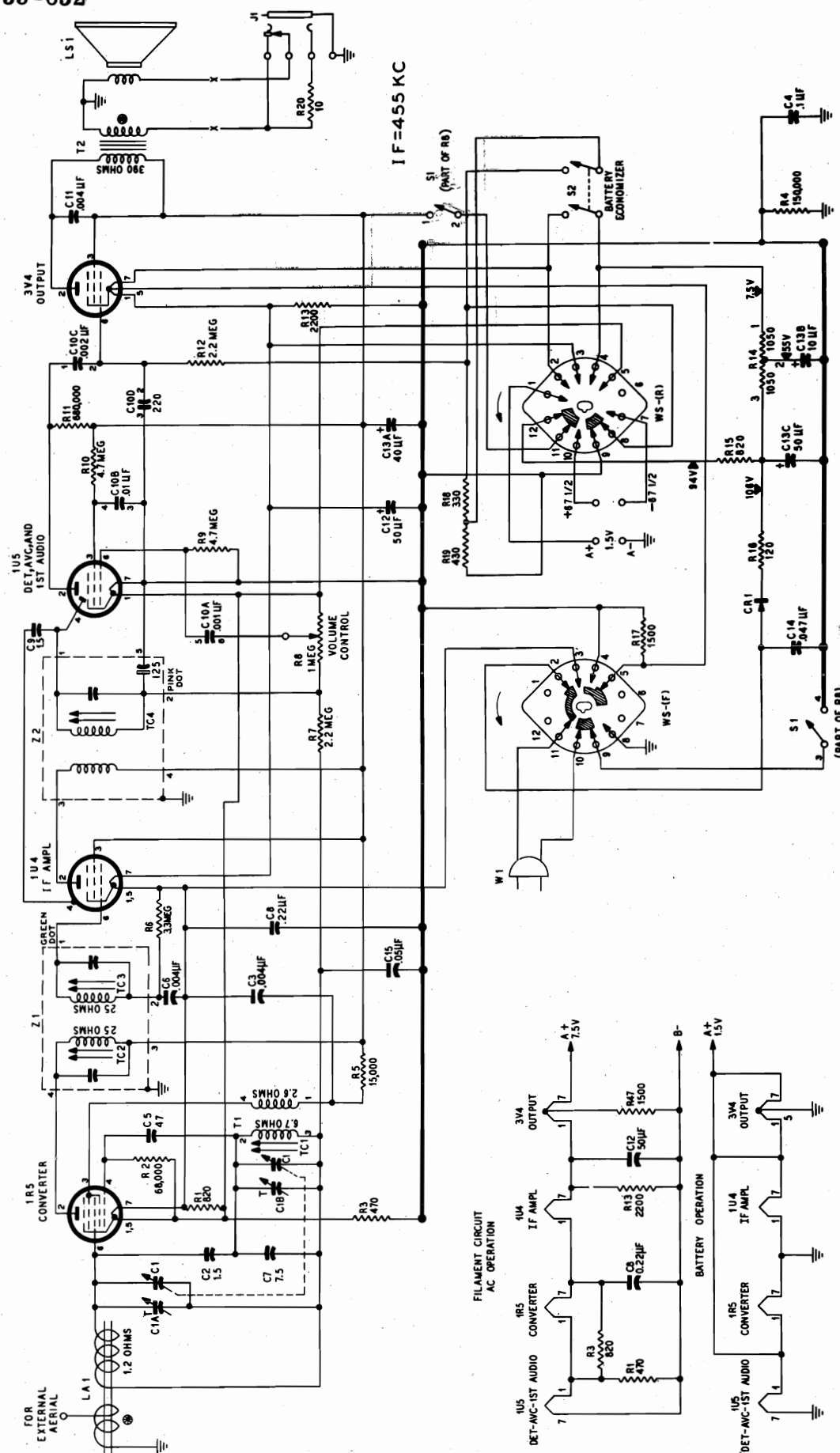
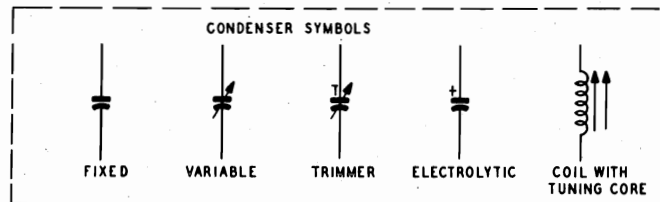

Figure 5. Philco Portable Radio Model 53-652, Schematic Diagram



NOTES:
 ALL RESISTOR VALUES IN OHMS AND ALL CONDENSER VALUES IN μF UNLESS OTHERWISE MARKED.
 ⊕ LESS THAN 1 OHM
 ALL VOLTAGES SHOWN WERE MEASURED WITH A 20,000 OHMS-PER-VOLT METER FROM POINTS INDICATED TO B-.

PARTS LIST

NOTE: Part numbers identified by an asterisk (*) are general replacement items. These numbers may not be identical with those on factory parts. Also, the electrical values of some replacement items may differ from the values indicated in the schematic diagram and parts list. The values substituted in any case are so chosen that the operation will either be unchanged or improved. When ordering replacements, use only the "Service Part No."

Reference Symbol	Description	Service Part No.
C1	Condenser, tuning gang	31-2735-4
C1A	Condenser, trimmer, antenna	Part of C1
C1B	Condenser, trimmer, oscillator	Part of C1
C2	Condenser, i-f neutralizing, 1.5 μf .	30-1221-7
C3	Condenser, screen by-pass, .004 μf .	30-1239*
C4	Condenser, B- to chassis, .1 μf .	30-4650-47*
C5	Condenser, d-c blocking, 47 μf .	60-00475420*
C6	Condenser, grid by-pass, .004 μf .	30-1239*
C7	Condenser, temperature compensating, 7.5 μf .	30-1224-83
C8	Condenser, filament by-pass, .25 μf .	30-4656-1
C9	Condenser, neutralizing, 1.5 μf .	30-1221-7
C10	Condenser, audio circuit	30-1237
C10A	Condenser, audio coupling, .001 μf .	Part of C10
C10B	Condenser, screen by-pass, .01 μf .	Part of C10
C10C	Condenser, d-c blocking, .002 μf .	Part of C10
C10D	Condenser, grid by-pass, 220 μf .	Part of C10
C11	Condenser, tone compensation, .004 μf .	30-4650-56*
C12	Condenser, electrolytic, filament by-pass, 50 μf .	30-2417-12
C13	Condenser, electrolytic, filter	30-2568-39
C13A	Condenser, filter, 40 μf .	Part of C13
C13B	Condenser, filter, 10 μf .	Part of C13
C13C	Condenser, filter, 50 μf .	Part of C13
C14	Condenser, line by-pass, .047 μf .	30-4650-45*
C15	Condenser, a-v-c by-pass, .05 μf .	30-4650-45*
CR1	Rectifier, selenium	34-8003
J1	Private listening unit	42-1975-2
LA1	Coil, antenna	32-4455-9
LS1	Loudspeaker	36-1637
R1	Resistor, filament dropping, 820 ohms	66-1828340*
R2	Resistor, grid leak, 68,000 ohms	66-3688340*
R3	Resistor, cathode bias, 470 ohms	66-1478340*
R4	Resistor, B- to chassis, 150,000 ohms	66-4158340*
R5	Resistor, screen dropping, 15,000 ohms	66-3158340*
R6	Resistor, grid leak, 3.3 megohms	66-5338340*
R7	Resistor, a-v-c load, 2.2 megohms	66-5228340*
R8	Volume control, 1 megohm	33-5566-21
R9	Resistor, grid leak, 4.7 megohms	66-5478340*
R10	Resistor, screen dropping, 4.7 megohms	66-5478340*
R11	Resistor, plate load, 680,000 ohms	66-4688340*
R12	Resistor, grid leak, 2.2 megohms	66-5228340*
R13	Resistor, filament dropping, 2200 ohms	66-2228340*
R14	Resistor, limiting, 2100 ohms	33-3445
R15	Resistor, B+ filter, 820 ohms	66-1828340*
R16	Resistor, limiting, 120 ohms	33-1334-14

Reference Symbol	Description	Service Part No.
R17	Resistor, filament dropping, 1500 ohms	66-2158340*
R18	Resistor, battery economizer, 330 ohms	66-1338340*
R19	Resistor, battery economizer, 560 ohms	66-1568340*
R20	Resistor, private listening unit, 10 ohms	66-0108340*
S1	Switch, on-off	Part of R8
S2	Switch, battery economizer	42-1796-3
T1	Transformer, oscillator	32-4453-1
T2	Transformer, output	32-8434
W1	Line cord	L 2183*
WS1	Switch, wafar, battery to line	42-1925-1
Z1	Transformer, 1st i-f	32-4160-4A
Z2	Transformer, 2nd i-f	32-4454-1A

MISCELLANEOUS

Description	Service Part No.
Cabinet, light beige	10954
Back, cabinet, light beige	54-6010
Handle, cabinet, light beige	54-6012
Cabinet, spruce green	10954-2
Back, cabinet, spruce green	54-6010-1
Handle, cabinet, spruce green	54-6012-1
Cable, battery	41-3988-1
Clip, cabinet back (2)	56-9162
Dial scale	56-9986
Backplate assembly, dial	76-8177
Window, dial	54-6011
Drive cord, 25-ft. spool	45-8750*
Spring, gang drive	56-2617*
Spring, pointer drive	28-8953
Fastener, speaker baffle (2)	W2235-7FA9
Hinge, cabinet (2)	56-5457
Insulator, tuning-condenser mtg.	27-9508
Knobs, (2) light beige or spruce green	54-6016
Pointer assembly	76-8071
Ring, handle mtg. (2)	56-9987
Rubber mount, tuning-condenser mtg. (3)	27-4099-3
Shaft, tuning	56-7906FA42
Shield, tube base	56-3978-1FA3
Socket, tube (2)	27-6203
Socket, tube (2)	27-6203-12
Spring, hairpin, shaft mtg.	28-8610
Spring, retaining	57-1868FA11

SPECIFICATIONS

CABINET	Wood console, mahogany
CIRCUIT	Five-tube superheterodyne (plus rectifier)
FREQUENCY RANGE	
Broadcast	540 kc. to 1620 kc.
Special Services	1700 kc. to 3400 kc.
AUDIO OUTPUT	4.5 watts
OPERATING VOLTAGE	105—120 volts, a.c.
POWER CONSUMPTION	80 watts
ANTENNA	Built-in, low-impedance loop
INTERMEDIATE FREQUENCY	455 kc.
PHILCO TUBES	6BJ6 r-f ampl; 6BE6 converter, osc., phono preampl; 6BJ6 i-f ampl; 6AV6 detector, a.v.c., 1st audio; 6AQ5 output; 6X4 rectifier



MODEL 53-1754

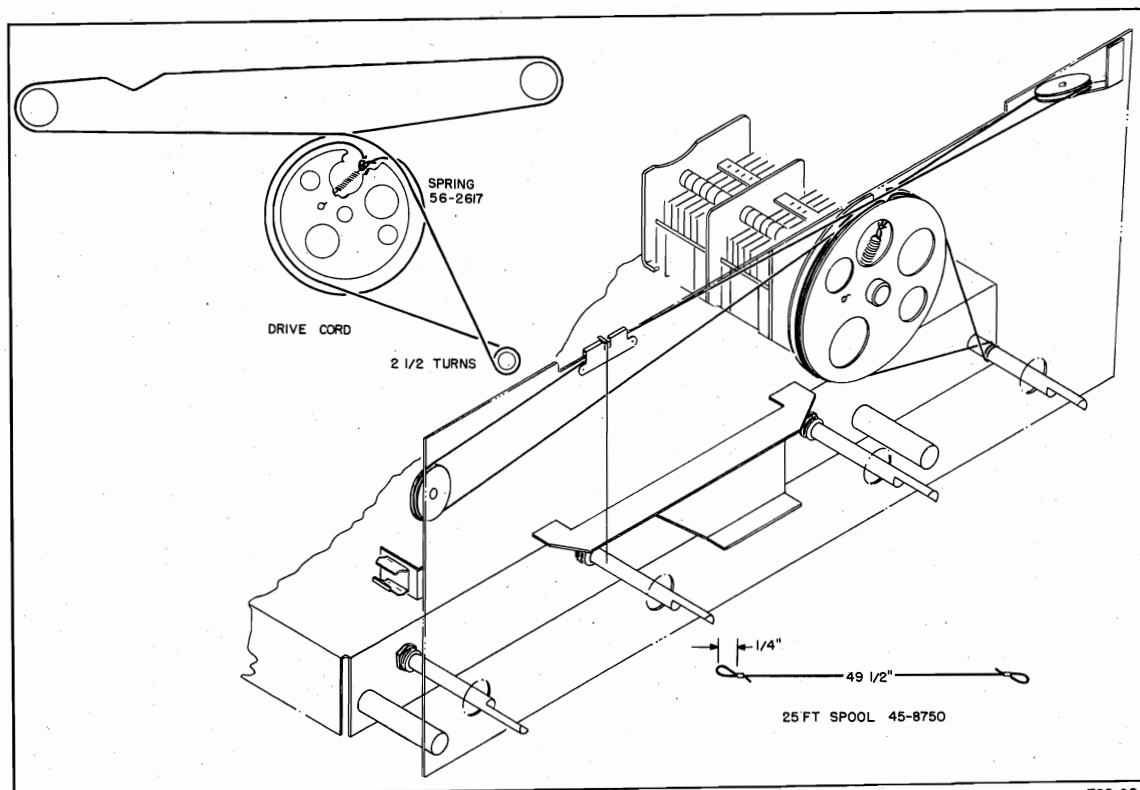

Figure 1. Drive-Cord Installation Details

TP2-3243

ALIGNMENT PROCEDURE

GENERAL

RADIO CONTROLS—Set volume control for maximum output, and set tuning control as indicated in the alignment chart. Set band switch to broadcast position for first 5 steps, then to special services position for steps 6 and 7.

OUTPUT INDICATOR—Connect output indicator (either an oscilloscope or a 1000-ohms-per-volt, a-c voltmeter) across voice-coil terminals.

SIGNAL GENERATOR—Use an AM r-f generator, connected as indicated in the alignment chart.

OUTPUT LEVEL—During alignment, attenuate signal-generator output to maintain output indication below 1 volt.

DIAL POINTER—Before the alignment is started, the dial pointer should be set to coincide with the dial scale mark to the left of "55" when the tuning gang is fully meshed.

ALIGNMENT CHART

STEP	SIGNAL GENERATOR		RADIO		ADJUST
	CONNECTION TO RADIO	DIAL SETTING	DIAL SETTING	SPECIAL INSTRUCTIONS	
1	Ground lead to chassis. Output lead through a .01- μ f. condenser to pin 7 (mixer grid) of 6BE6, converter.	455 kc.	Tuning gang fully open.	Adjust, in order given in next column, for maximum output.	TC6—2nd i-f sec. TC3—1st i-f pri. TC5—2nd i-f pri. TC4—1st i-f sec.
2	Radiating loop. See Note 1 below.	1620 kc.	1620 kc. See Note 2 below.	Adjust for maximum output.	C1C—osc. trimmer
3	Same as step 2.	1520 kc.	Tune radio to generator signal.	Adjust for maximum output. (High-frequency adjustment)	C1B—mixer-grid trimmer C1A—r-f trimmer
4	Same as step 2.	580 kc.	Same as step 3.	Adjust for maximum output. (Low-frequency adjustment)	TC2—r-f transformer
5	Repeat steps 3 and 4 until no further improvement is obtained.				
6	Same as step 2.	3200 kc.	Same as step 3.	Adjust for maximum output.	C10—special services mixer-grid trimmer C4—special services r-f trimmer
7	Same as step 2.	1800 kc.	Same as step 3.	Adjust for maximum output.	C2—special services r-f padder

NOTE 1: Make up a 6-8 turn, 6-inch-diameter loop from insulated wire; connect to signal-generator leads and place about 1 foot from radio loop antenna. The position of the radio loop with respect to the chassis should be approximately the same as when both are mounted in the cabinet.

NOTE 2: To set the tuning gang to 1620 kc., place a piece of 6-mil flat shim stock beneath the heel of the rotor, and turn the rotor until it holds the shim firmly in place. Then remove the shim.

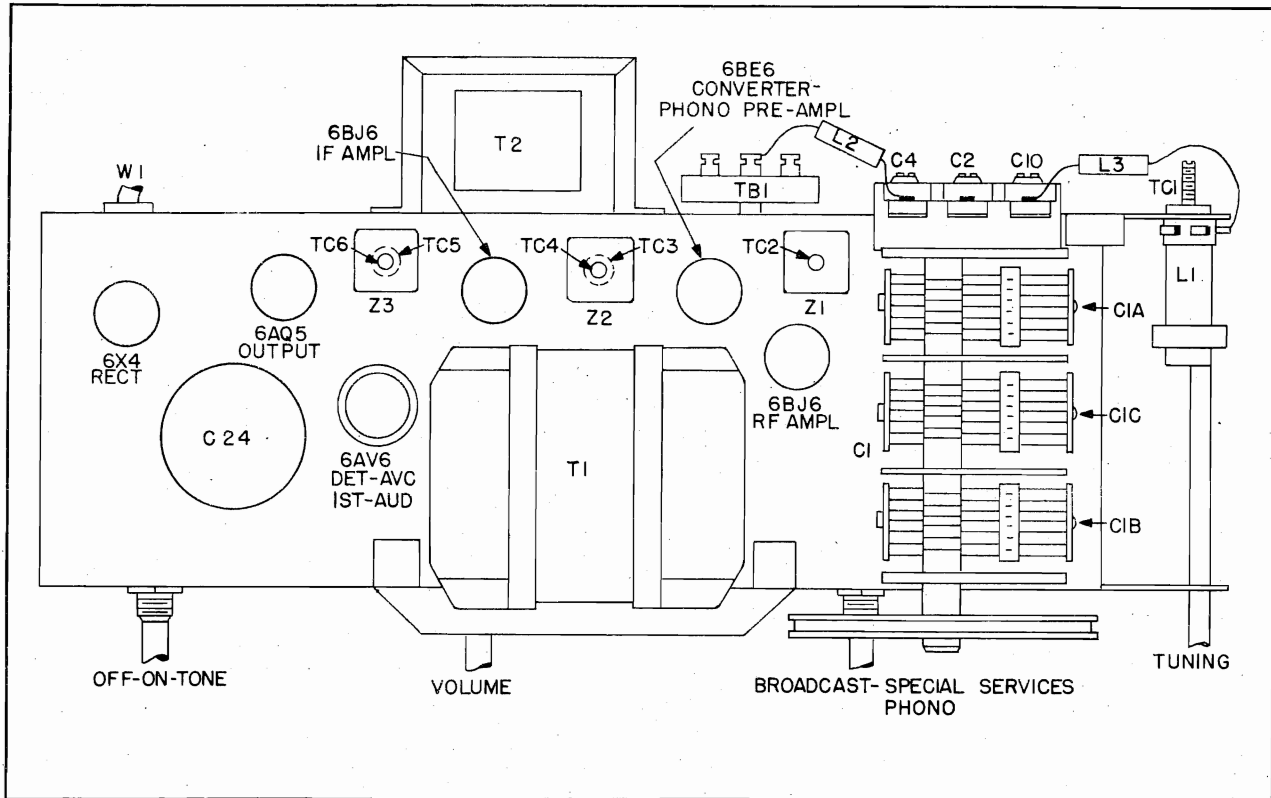

Figure 2. Top View, Showing Tuning Adjustments

TP2-3245

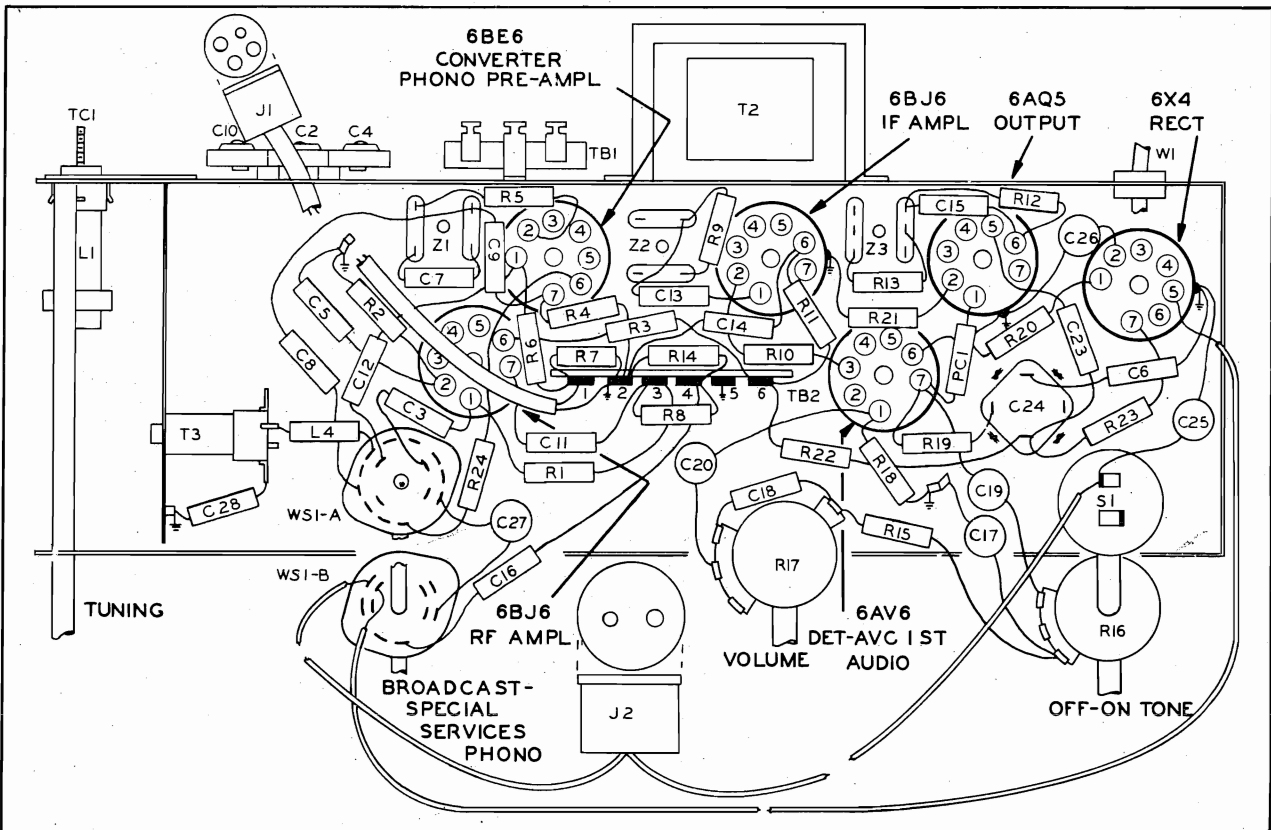

Figure 3. Base View, Showing Parts Placement

TP2-3244

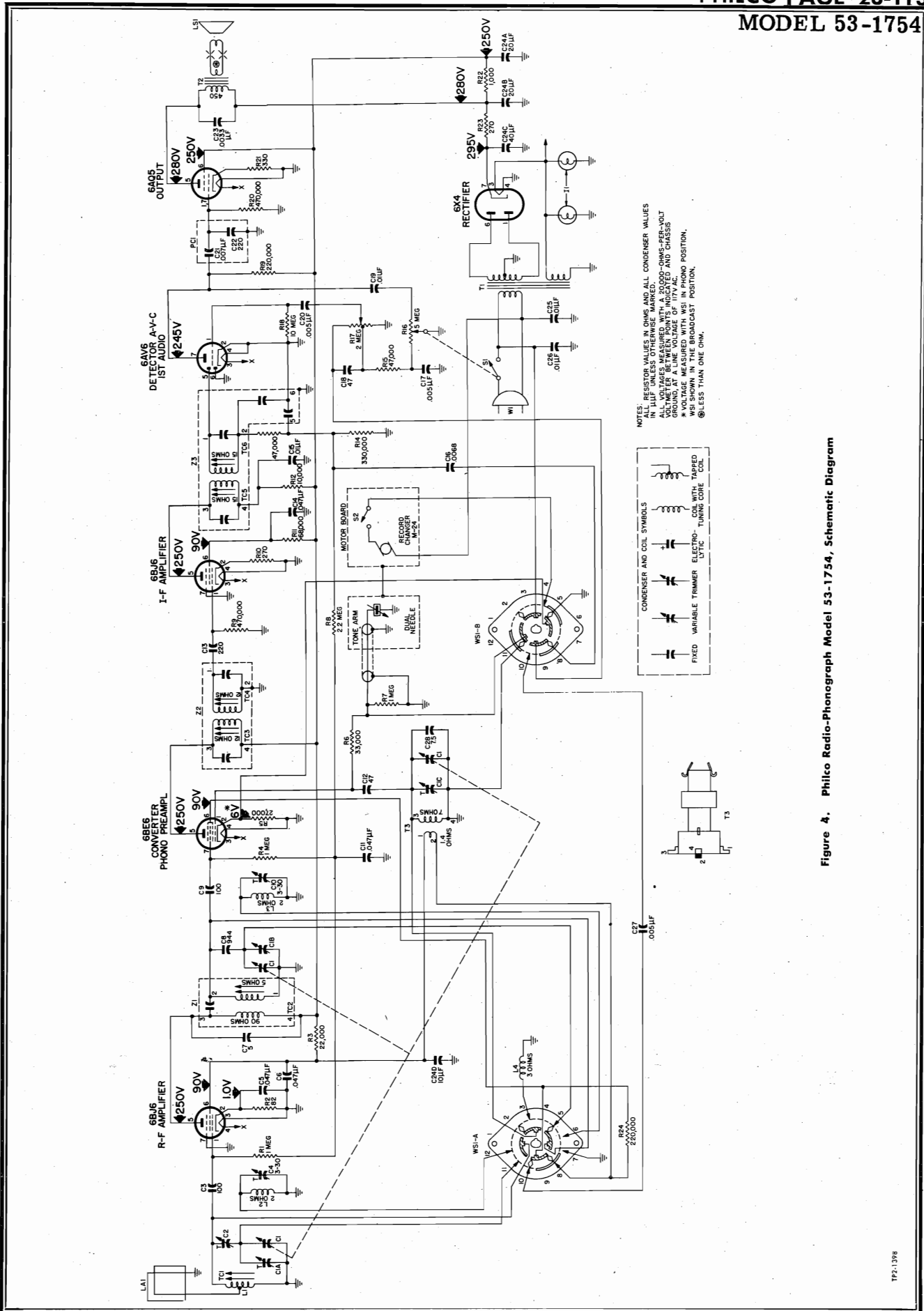
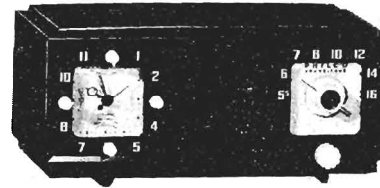

Figure 4. Philco Radio-Phonograph Model 53-1754, Schematic Diagram



TP2-3233

MODEL 53-701X
SPECIFICATIONS

CABINETMolded phenolic
 CIRCUITFour-tube superheterodyne (plus rectifier)
 FREQUENCY RANGE540—1620 kc.
 AUDIO OUTPUT1 watt
 OPERATING VOLTAGE117 volts, a.c.
 POWER CONSUMPTION30 watts
 ANTENNAHigh-impedance loop

INTERMEDIATE FREQUENCY455 kc.
 PHILCO TUBES12BE6, converter; 12BA6, i-f amplifier;
 12AV6, det.—a.v.c.—1st audio; 35C5,
 output; 35W4, rectifier

NOTE: The antenna is mounted on the cabinet back. When removing the cabinet back, use care to avoid breaking the antenna leads.

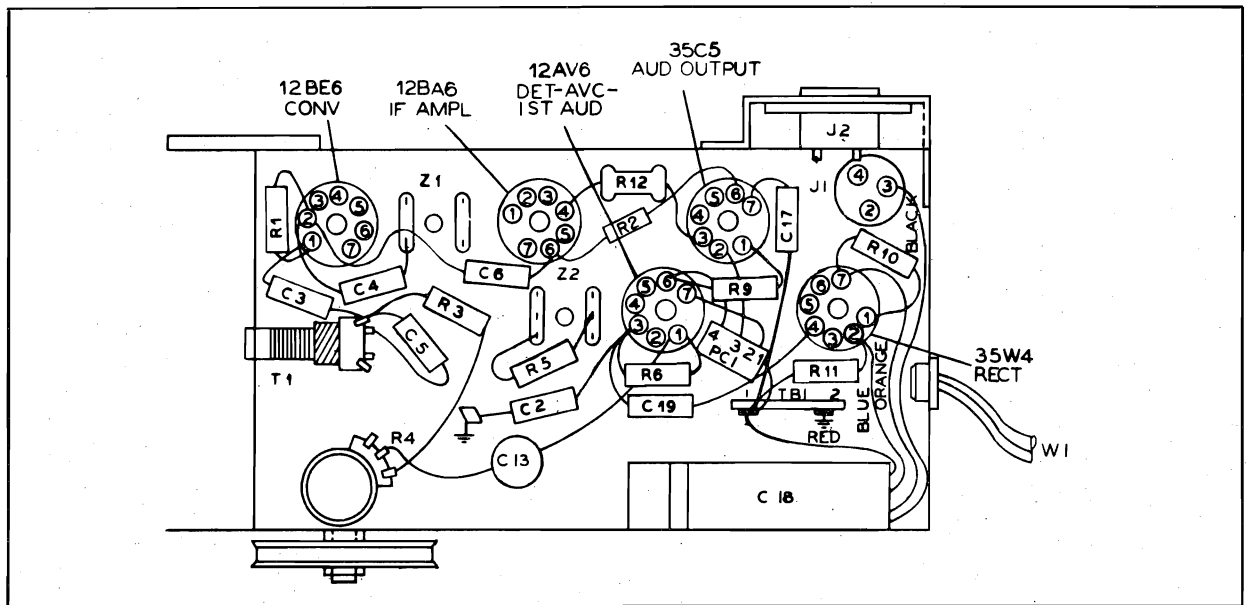

Figure 1. Base View, Showing Parts Placement

P2-3231

PR-2482

ALIGNMENT PROCEDURE

RADIO CONTROLS—Set volume control to maximum. Set tuning control as indicated in chart.

OUTPUT METER—Connect across voice-coil terminals.

SIGNAL GENERATOR—Connect generator and set frequency as indicated in chart. Use modulated output.

OUTPUT LEVEL—During alignment, adjust signal-generator output to hold output-meter reading below 1.25 volts.

ALIGNMENT CHART

STEP	SIGNAL GENERATOR		RADIO		ADJUST
	CONNECTION TO RADIO	DIAL SETTING	DIAL SETTING	SPECIAL INSTRUCTIONS	
1	Ground lead to B-; output lead through a .1- μ f. condenser to grid (pin 7) of 12BE6.	455 kc.	Tuning gang fully open.	Adjust tuning cores, in order given, for maximum output. (TC1 and TC3 are located at top of transformers.)	TC4—2nd i-f sec. TC3—2nd i-f pri. TC2—1st i-f sec. TC1—1st i-f pri.
2	Radiating loop (see note below).	1620 kc.	1620 kc.*	Adjust trimmer for maximum output.	C1B—osc.
3	Same as step 2.	1500 kc.	1500 kc.†	Adjust trimmer for maximum output.	C1A—antenna

NOTE: Make a 6–8 turn, 6-inch-diameter loop from insulated wire; connect to signal-generator leads, and place about 1 foot from radio loop. The position of the radio loop with respect to the chassis should be approximately the same as when both are mounted in the cabinet.

* To set the tuning gang to 1620 kc., fully open the gang and insert a .006-inch, nonmetallic shim between the heel of the rotor and the top of the stator plates. Close the gang sufficiently to hold the shim in place, and then remove the shim without disturbing the gang setting.

† To set the radio to 1500 kc., place chassis in cabinet, attach knob to indicate previous setting of 1620 kc., and tune until pointer indicates 1500 kc. Then remove knob and take chassis from cabinet without disturbing gang setting.

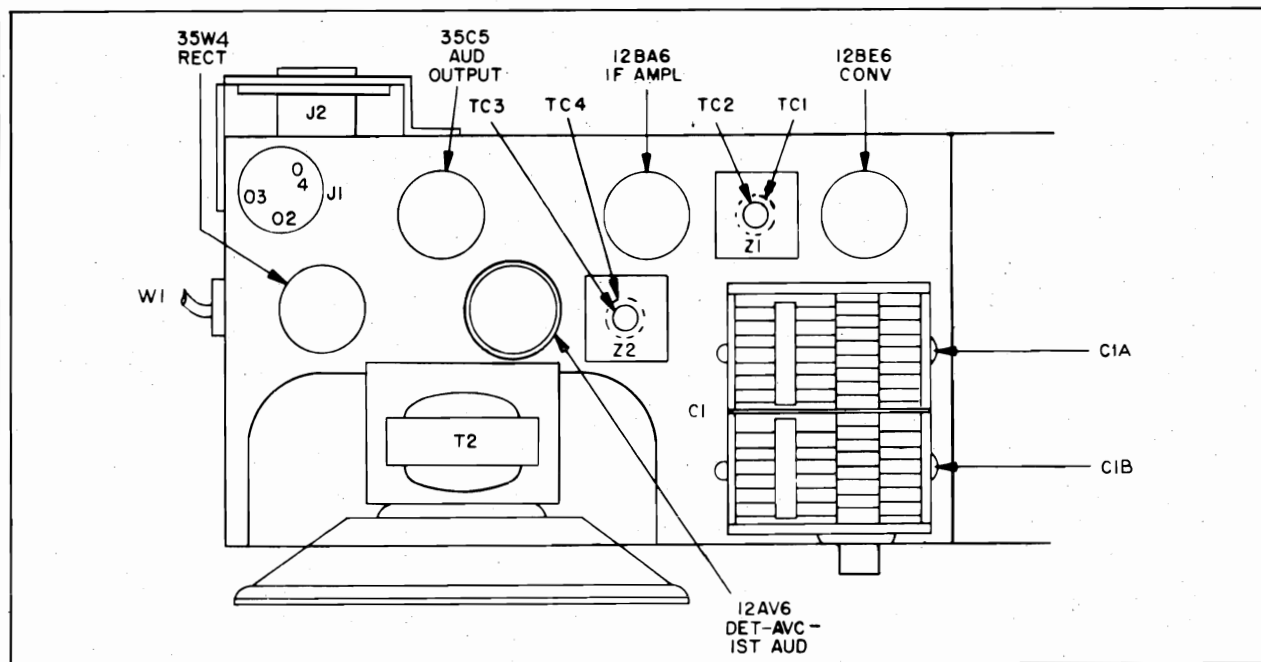

TP2-3232

Figure 2. Top View, Showing Tuning Adjustments

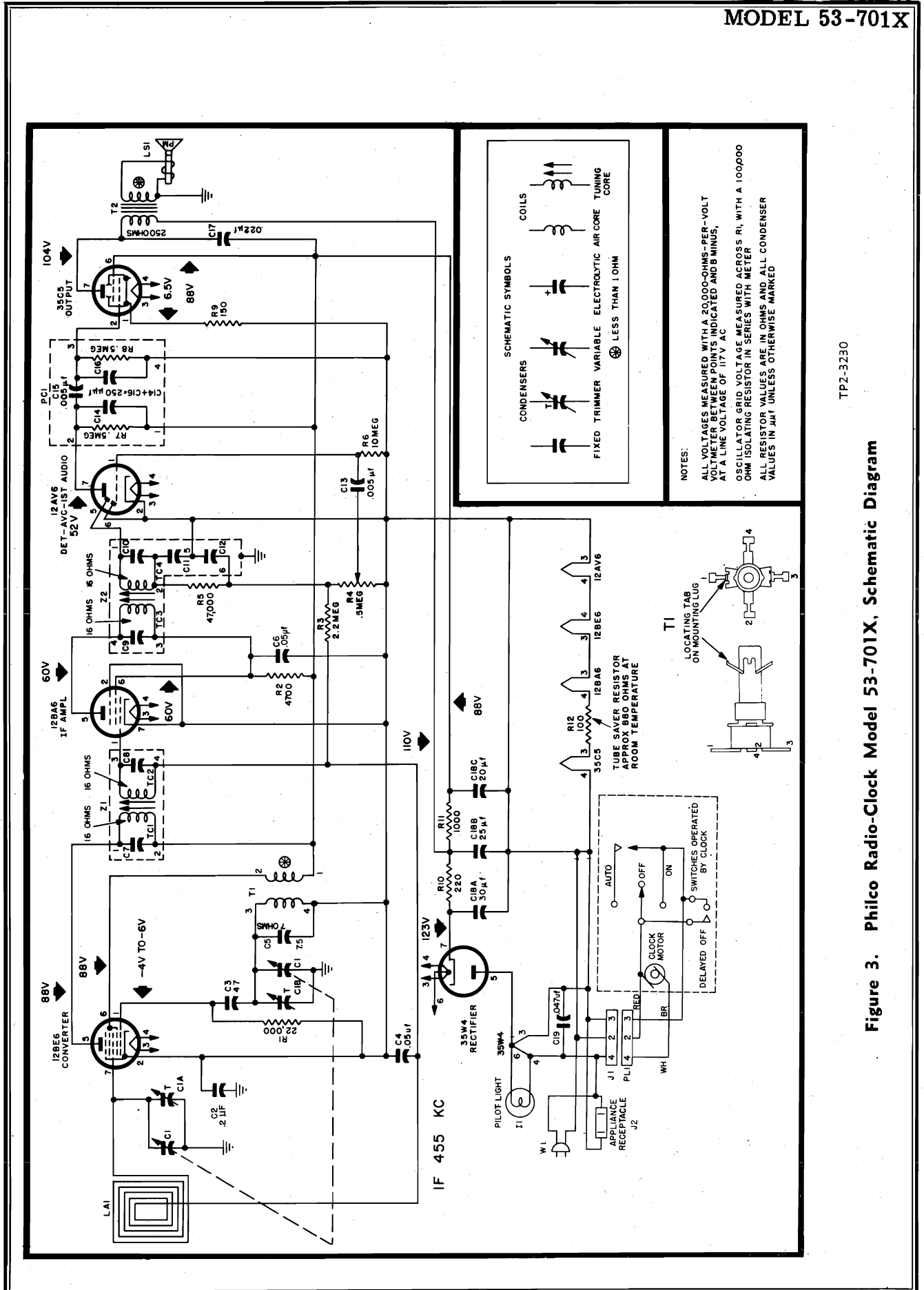

TP2-3230

Figure 3. Philco Radio-Clock Model 53-701X, Schematic Diagram

PARTS LIST

NOTE: Part numbers identified by an asterisk (*) are general replacement items. These numbers may not be identical with those on factory parts. Also, the electrical values of some replacement items may differ from the values indicated in the schematic diagram and parts list. The values substituted in any case are so chosen that the operation will be either unchanged or improved. When ordering replacements, use only the "Service Part No."

Reference Symbol	Description	Service Part No.
C1	Condenser, tuning gang	31-2751-13
C1A	Condenser, r-f trimmer	Part of C1
C1B	Condenser, oscillator trimmer	Part of C1
C2	Condenser, B- to chassis, .2 μ f.	30-4650-49
C3	Condenser, oscillator grid, 47 μ f.	30-1230-4
C4	Condenser, α -v-c by-pass, .05 μ f.	30-4650-45*
C5	Condenser, drift compensation, 7.5 μ f.	30-1224-83
C6	Condenser, screen by-pass, .05 μ f.	30-4650-45*
C7	Condenser, i-f tuning	Part of Z1
C8	Condenser, i-f tuning	Part of Z1
C9	Condenser, i-f tuning	Part of Z2
C10	Condenser, i-f tuning	Part of Z2
C11	Condenser, detector filtering	Part of Z2
C12	Condenser, detector filtering	Part of Z2
C13	Condenser, audio coupling, .005 μ f.	30-1238-1
C14	Condenser, plate by-pass	Part of PC1
C15	Condenser, audio coupling, .005 μ f.	Part of PC1
C16	Condenser, compensating	Part of PC1
C17	Condenser, tone compensation, .022 μ f.	30-4650-43*
C18	Condenser, electrolytic, 3-section	30-2573
C18A	Condenser, filter, 30 μ f., 150v	Part of C18
C18B	Condenser, filter, 25 μ f., 150v	Part of C18
C18C	Condenser, filter, 20 μ f., 150v	Part of C18
C19	Condenser, line by-pass, .047 μ f.	30-4650-45*
I1	Lamp, pilot	34-2068
J1	Jack, clock	27-6273
J2	Jack, appliance receptacle, α -c	76-3931
LA1	Loop	Part of cabinet back
LS1	Speaker, p-m	36-1627-8
PC1	Printed circuit	30-6001
PL1	Plug, clock assembly	27-6273
R1	Resistor, oscillator grid, 22,000 ohms	66-3228340*
R2	Resistor, i-f screen dropping, 4700 ohms	66-2478340*
R3	Resistor, α -v-c filter, 2.2 megohms	66-5228340*
R4	Resistor, volume control, .5 megohm	33-5566-41
R5	Resistor, diode load, 47,000 ohms	66-3478340*
R6	Resistor, grid return, 10 megohms	66-6108340
R7	Resistor, plate load, 500,000 ohms	Part of PC1
R8	Resistor, grid return, 500,000 ohms	Part of PC1
R9	Resistor, cathode bias, 150 ohms	66-1158340*
R10	Resistor, B plus filter, 220 ohms, 1 watt	66-1224340*
R11	Resistor, B plus filter, 1000 ohms	66-2108340*
R12	Resistor, tube saver, 100 ohms	33-1343-3
T1	Transformer, oscillator	33-4453-6
T2	Transformer, output	32-8384*
W1	Line cord	L2183*
Z1	Transformer, 1st i-f	32-4161A
Z2	Transformer, 2nd i-f	32-4240A

Description	Service Part No.
Cabinet	10924-6
Knobs	
Clock (4 required)	54-4983
Station selector	54-4978
Off-on	54-4118
Clock	41-2041-1
Back-and-loop assembly	76-7757-3
Shield, tube	56-5629FA3
Clip, pilot lamp	W2563FA3
Socket, miniature (5 required)	27-6265*
Socket assembly, pilot lamp	27-6233-6
Window, radio dial	54-4977-2

MISCELLANEOUS

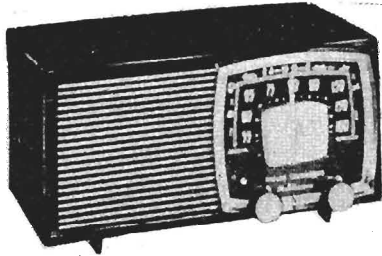

TP2-3248

MODEL 53-565

SPECIFICATIONS

CABINET	Molded plastic
CIRCUIT	Four-tube superheterodyne (plus rectifier)
FREQUENCY RANGE	
Standard Broadcast	540 kc. to 1620 kc.
Special Services	1700 kc. to 3400 kc.
AUDIO OUTPUT	1 watt
OPERATING VOLTAGE	105 to 120 volts, a.c. or d.c.
POWER CONSUMPTION	30 watts
ANTENNA	High-impedance loop
INTERMEDIATE FREQUENCY	455 kc.
PHILCO TUBES	12BE6, converter; 12BA6, i-f amplifier; 12AV6, det.—a.v.c.—1st audio; 35C5, output; 35W4, rectifier

Note: The antenna is mounted on the cabinet back. When removing the cabinet back, use care to avoid breaking the antenna leads.

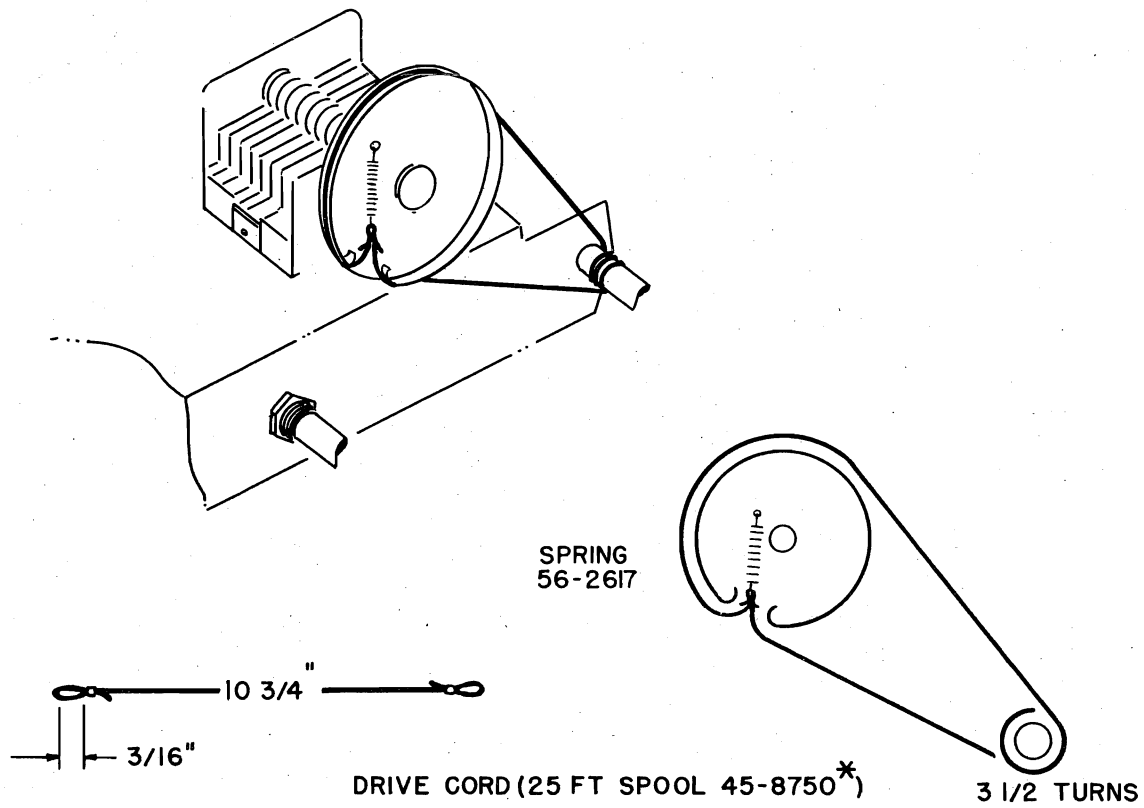

TP2-1405

Figure 1. Dial-Cord Installation Details

PR-2480

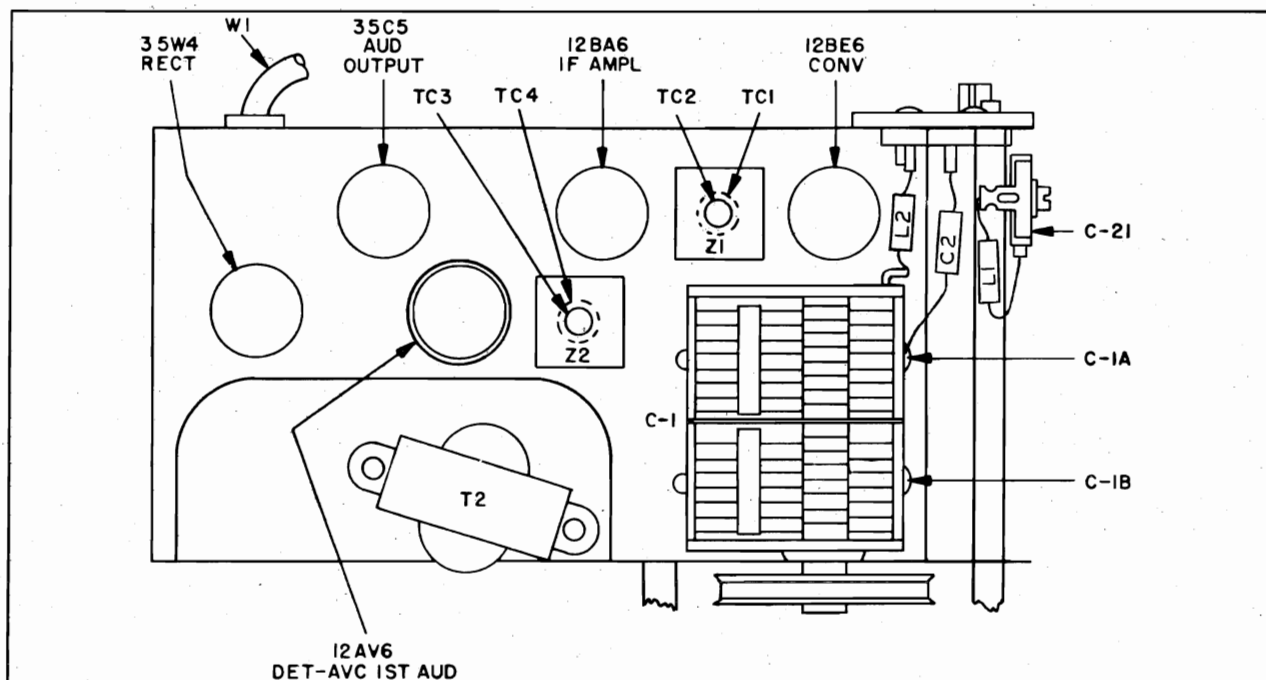

TP2-1407

Figure 2. Top View, Showing Tuning Adjustments

ALIGNMENT PROCEDURE

RADIO CONTROLS—Set volume control to maximum. Set tuning control and band switch, SW1, as indicated in chart.

OUTPUT METER—Connect across voice-coil terminals.

SIGNAL GENERATOR—Connect generator and set frequency as indicated in chart. Use modulated output.

OUTPUT LEVEL—During alignment, adjust signal-generator output to hold output-meter reading below 1.25 volts.

ALIGNMENT CHART

STEP	SIGNAL GENERATOR		RADIO			ADJUST
	CONNECTION TO RADIO	DIAL SETTING	DIAL SETTING	BAND-SWITCH SETTING	SPECIAL INSTRUCTIONS	
1	Ground lead to B—; output lead through a .1- μ f. condenser to grid (pin 7) of 12BE6.	455 kc.	Tuning gang fully open.	Broadcast	Adjust tuning cores, in order given, for maximum output. (TC1 and TC3 are located at top of transformers.)	TC4—2nd i-f sec. TC3—2nd i-f pri. TC2—1st i-f sec. TC1—1st i-f pri.
2	Use radiating loop (see NOTE below).	1620 kc.	*1620 kc.	Broadcast	Adjust trimmer for maximum output.	C1B—osc.
3	Same as step 2.	1500 kc.	†1500 kc.	Broadcast	Adjust trimmer for maximum output.	C1A—antenna (broadcast)
4	Same as step 2.	3200 kc.	†3200 kc.	Special services	Adjust trimmer for maximum output.	C21—antenna (special services)

NOTE: Make up a 6–8 turn, 6-inch-diameter loop from insulated wire; connect to signal-generator leads and place about 1 foot from radio loop. The position of the radio loop with respect to the chassis should be approximately the same as when both are mounted in the cabinet.

* To set the tuning gang to 1620 kc., fully open the gang and insert a .006-inch nonmetallic shim between the heel of the rotor and the top of the stator plates. Close the gang sufficiently to hold the shim in place, and then remove the shim without disturbing the gang setting.

† To set the tuning gang to this frequency, put the chassis into the cabinet, tune the dial until it indicates the proper frequency on the dial scale, and then remove the chassis from the cabinet without disturbing the gang setting.

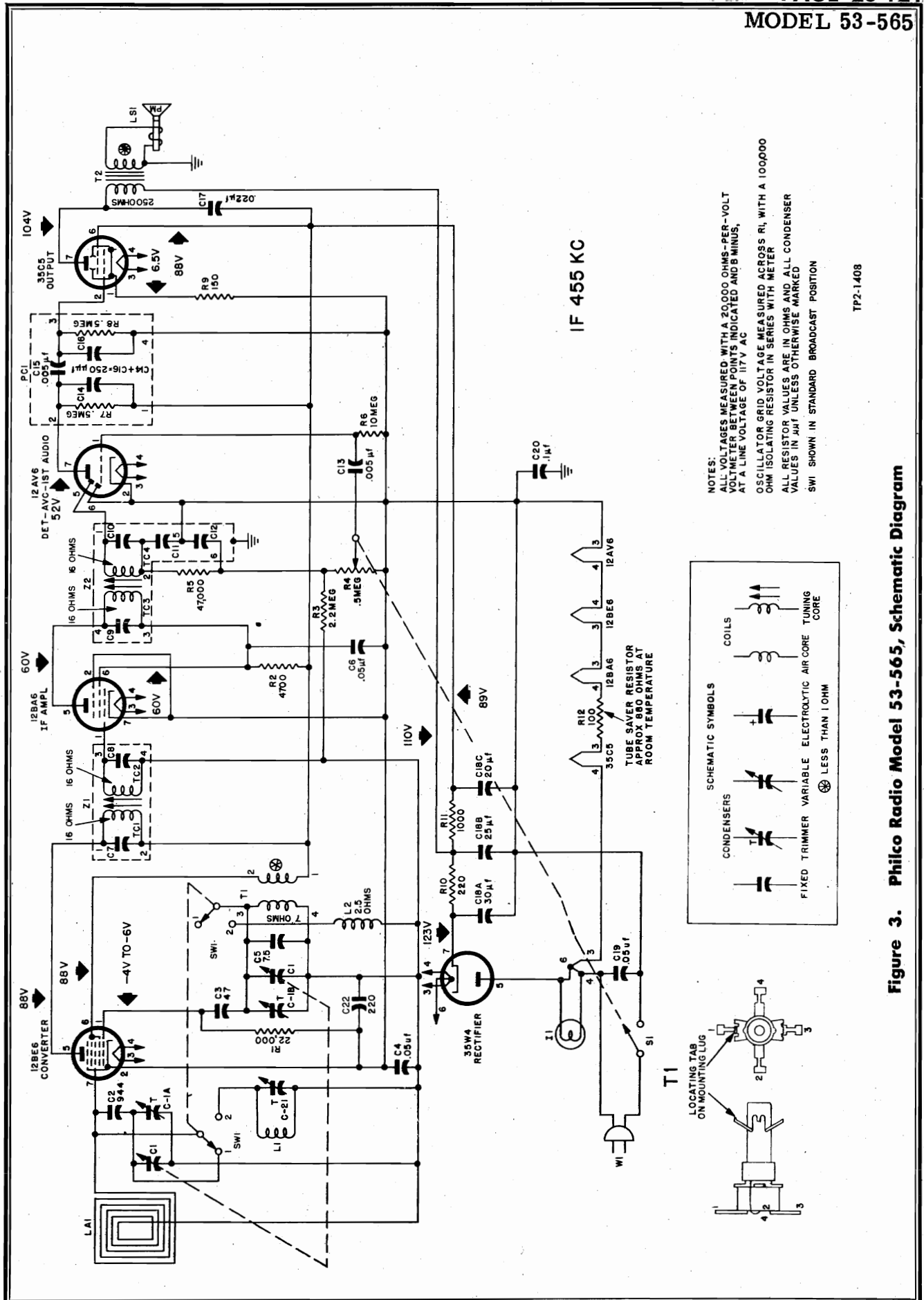

TP2-1408

Figure 3. Philco Radio Model 53-565, Schematic Diagram

MODEL 565

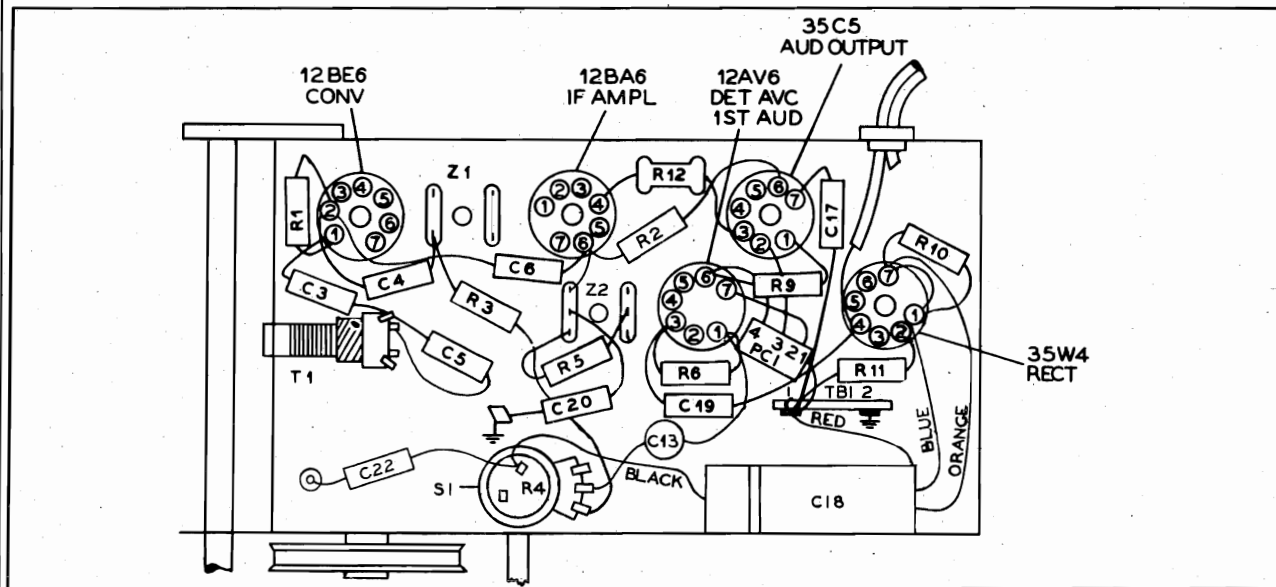

Figure 4. Base View, Showing Parts Placement

TP2-1406

PARTS LIST

NOTE: Part numbers identified by an asterisk (*) are general replacement items. These numbers may not be identical with those on factory parts. Also, the electrical values of some replacement items may differ from the values indicated in the schematic diagram and parts list. The values substituted in any case are so chosen that the operation will be unchanged. When ordering replacements, use only the "Service Part No."

Reference Symbol	Description	Service Part No.	Reference Symbol	Description	Service Part No.
C1	Condenser, tuning gang	31-2751-14	R3	Resistor, a-v-c filter, 2.2 megohms	66-5228340*
C1A	Condenser, antenna trimmer	Part of C1	R4	Resistor, volume control	33-5566-41
C1B	Condenser, osc. trimmer	Part of C1	R5	Resistor, diode load, 47,000 ohms	66-3478340*
C2	Condenser, antenna series tracker, 944 $\mu\text{f.}$	30-1220-65	R6	Resistor, grid return, 10 megohms	66-6108340*
C3	Condenser, oscillator grid, 47 $\mu\text{f.}$	30-1230-4	R7	Resistor, plate load, 500,000 ohms	Part of PC1
C4	Condenser, a-v-c by-pass, .05 $\mu\text{f.}$	30-4650-45*	R8	Resistor, grid return, 500,000 ohms	Part of PC1
C5	Condenser, drift compensation, 7.5 $\mu\text{f.}$	30-1224-83	R9	Resistor, cathode bias, 150 ohms	66-1158340*
C6	Condenser, screen by-pass, .05 $\mu\text{f.}$	30-4650-45*	R10	Resistor, B plus filter, 220 ohms	66-1224340*
C7	Condenser, i-f tuning	Part of Z1	R11	Resistor, B plus filter, 1000 ohms	66-2108340*
C8	Condenser, i-f tuning	Part of Z1	R12	Resistor, tube saver, 100 ohms	33-1343-3
C9	Condenser, i-f tuning	Part of Z2	S1	Switch, off-on	Part of R4
C10	Condenser, i-f tuning	Part of Z2	SW1	Switch, broadcast-special services	42-1796-2
C11	Condenser, detector filtering	Part of Z2	T1	Transformer, oscillator	32-4453-6
C12	Condenser, detector filtering	Part of Z2	T2	Transformer, output	32-8384-4
C13	Condenser, audio coupling, .005 $\mu\text{f.}$	30-1238-1	W1	Line cord	L-2183*
C14	Condenser, plate by-pass	Part of PC1	Z1	Transformer, 1st i-f	32-4161A
C15	Condenser, audio coupling, .005 $\mu\text{f.}$	Part of PC1	Z2	Transformer, 2nd i-f	32-4240A
C16	Condenser, compensating	Part of PC1			
C17	Condenser, tone compensation, .022 $\mu\text{f.}$	30-4650-43*			
C18	Condenser, electrolytic, 3-section	30-2575-34			
C18A	Condenser, filter, 30 $\mu\text{f.}$, 150v.	Part of C18			
C18B	Condenser, filter, 25 $\mu\text{f.}$, 150v.	Part of C18			
C18C	Condenser, filter, 20 $\mu\text{f.}$, 150v.	Part of C18			
C19	Condenser, line by-pass, .05 $\mu\text{f.}$	30-4650-45*			
C20	Condenser, B- to chassis, .1 $\mu\text{f.}$	30-4650-47*			
C21	Condenser, trimmer, special services	31-6473-29			
I1	Lamp, pilot	34-2068			
LA1	Loop, antenna	Part of cabinet back			
L1	Coil, antenna, special services	32-4561-3			
L2	Coil, oscillator shunt	32-4562-2			
LS1	Speaker, p-m	36-1625-3			
PC1	Printed circuit	30-6001			
R1	Resistor, oscillator grid, 22,000 ohms	66-3228340*			
R2	Resistor, i-f screen dropping, 4700 ohms	66-2478340*			

MISCELLANEOUS

Description	Service Part No.
Cabinet	
Spruce	10927-4
Ebony	10927
Back-and-loop assembly	76-7769
Knob (2)	54-4982-1
Drive cord, 25-foot spool	45-8750*
Pointer, dial	54-4979
Shaft, tuning	56-9807FA11
Socket assembly, pilot lamp	27-6233-6
Socket, 7-pin miniature	27-6265*
Socket (12AV6)	27-6203-14*
Spring, retaining	28-8610
Spring, dial cord	56-2617

SPECIFICATIONS

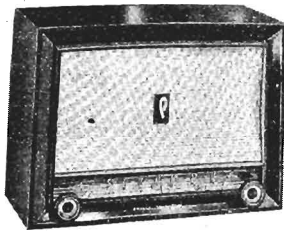

MODEL 53-568

CABINET	Molded plastic
CIRCUIT	Four-tube superheterodyne (plus rectifier)
FREQUENCY RANGE	
Standard Broadcast	540 kc. to 1620 kc.
Special Services	1700 kc. to 3400 kc.
AUDIO OUTPUT	1 watt
OPERATING VOLTAGE	105 to 120 volts, a.c. or d.c.
POWER CONSUMPTION	30 watts
ANTENNA	High-impedance loop
INTERMEDIATE FREQUENCY	455 kc.
PHILCO TUBES	12BE6, converter; 12BA6, i-f amplifier; 12AV6, det.-a.v.c.-1st audio; 35C5, output; 35W4, rectifier

NOTE: The antenna is mounted on the cabinet back. When removing the cabinet back, use care to avoid breaking the antenna leads.

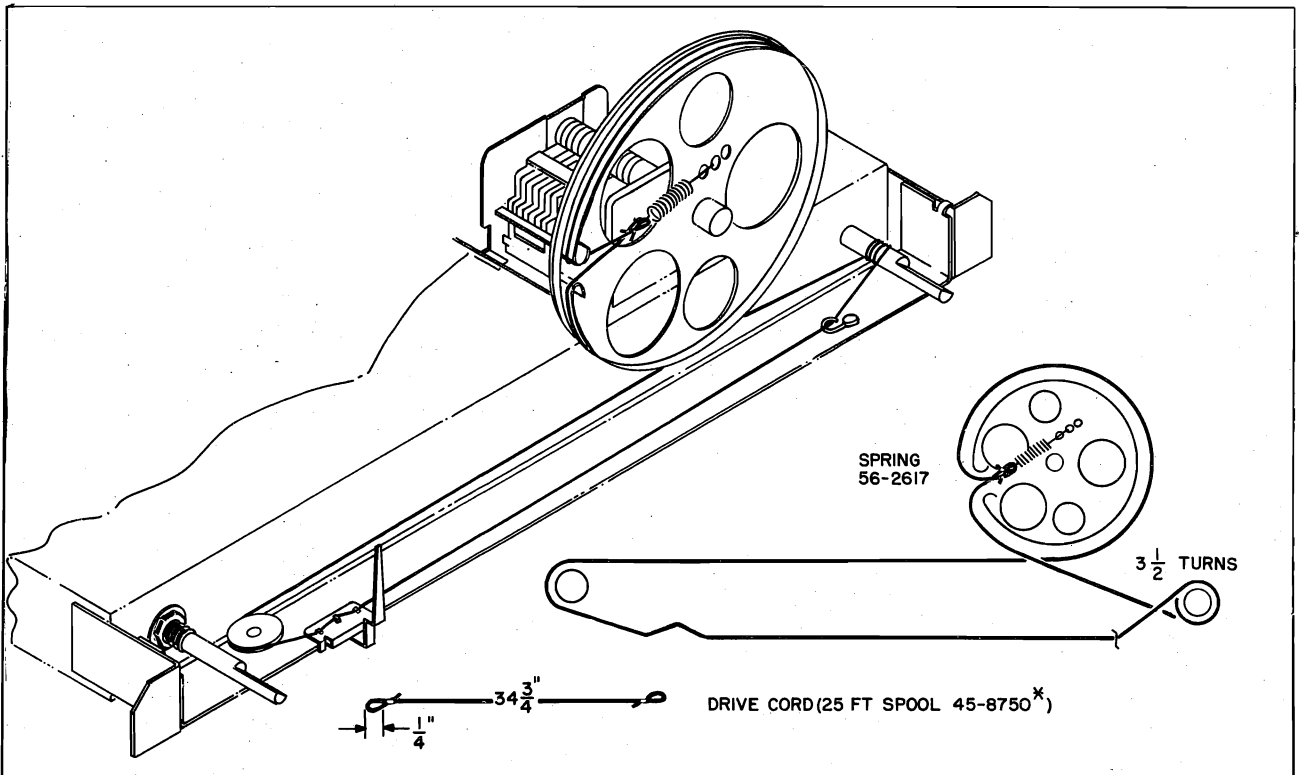

Figure 1. Dial-Cord Installation Details

TP2-3193

PR-2481

ALIGNMENT PROCEDURE

RADIO CONTROLS—Set volume control to maximum. Set tuning control and band switch, SW1, as indicated in chart.

OUTPUT METER—Connect across voice-coil terminals.

SIGNAL GENERATOR—Connect generator and set frequency as indicated in chart. Use modulated output.

OUTPUT LEVEL—During alignment, attenuate signal-generator output to hold output-meter reading below 1.25 volts.

ALIGNMENT CHART

STEP	SIGNAL GENERATOR		RADIO			ADJUST
	CONNECTION TO RADIO	DIAL SETTING	DIAL SETTING	BAND-SWITCH SETTING	SPECIAL INSTRUCTIONS	
1	Ground-lead to B-; output lead through a .1- μ f. condenser to grid (pin 7) of 12BE6.	455 kc.	Tuning gang fully open.	Broadcast	Adjust tuning cores, in order given, for maximum output. (TC1 and TC3 are located at top of transformers.)	TC4—2nd i-f sec. TC3—2nd i-f pri. TC2—1st i-f sec. TC1—1st i-f pri.
2	Radiating loop (see NOTE below).	1620 kc.	1620 kc.*	Broadcast	Adjust trimmer for maximum output.	C1B—osc.
3	Same as step 2.	1500 kc.	1500 kc.†	Broadcast	Adjust trimmer for maximum output.	C1A—antenna (broadcast)
4	Same as step 2.	3200 kc.	3200 kc.†	Special services	Adjust trimmer for maximum output.	C21—antenna (special services)

NOTE: Make up a 6—8 turn, 6-inch diameter loop from insulated wire; connect to signal-generator leads, and place 1 foot from radio loop. The position of the radio loop (LA1) with respect to the chassis, should be approximately the same as when both are mounted in the cabinet.

* To set the tuning gang to 1620 kc., fully open the tuning gang and insert a .006-inch nonmetallic shim between the heel of the rotor and the top of the stator plates. Close the tuning gang sufficiently to hold the shim in place, and then remove the shim without disturbing the gang setting. Then proceed with the remainder of step 2.

† † Place radio chassis in cabinet and set pointer to proper frequency; then remove chassis and proceed with adjustment of designated trimmer.

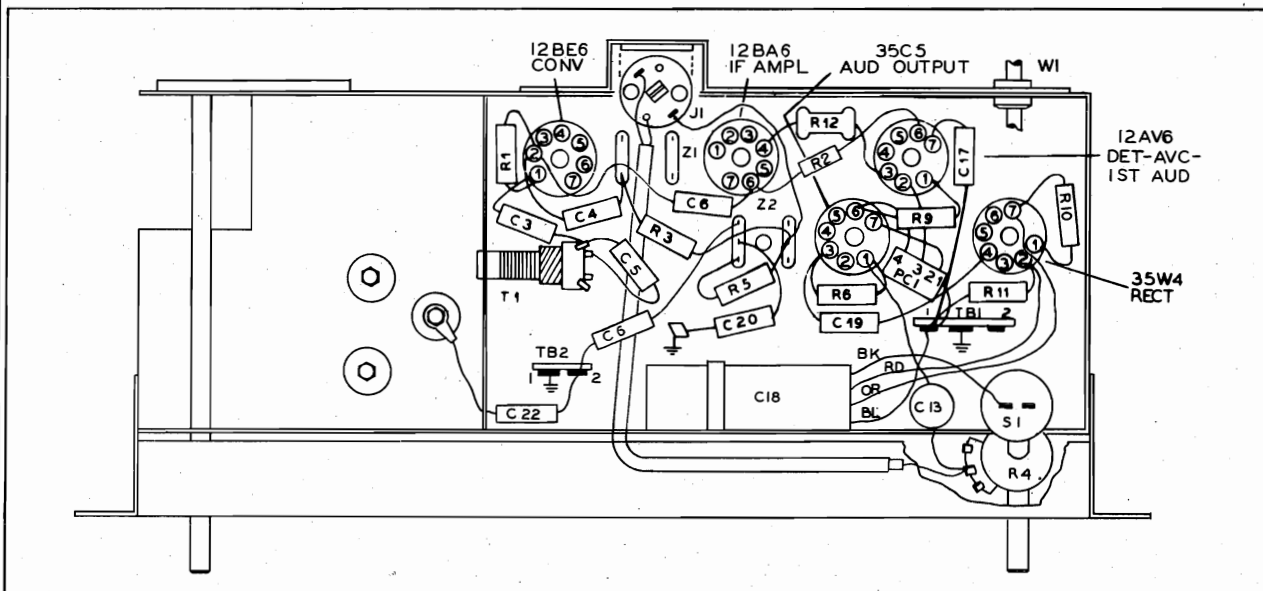

Figure 2. Base View. Showing Placement of Parts

TP2-3195

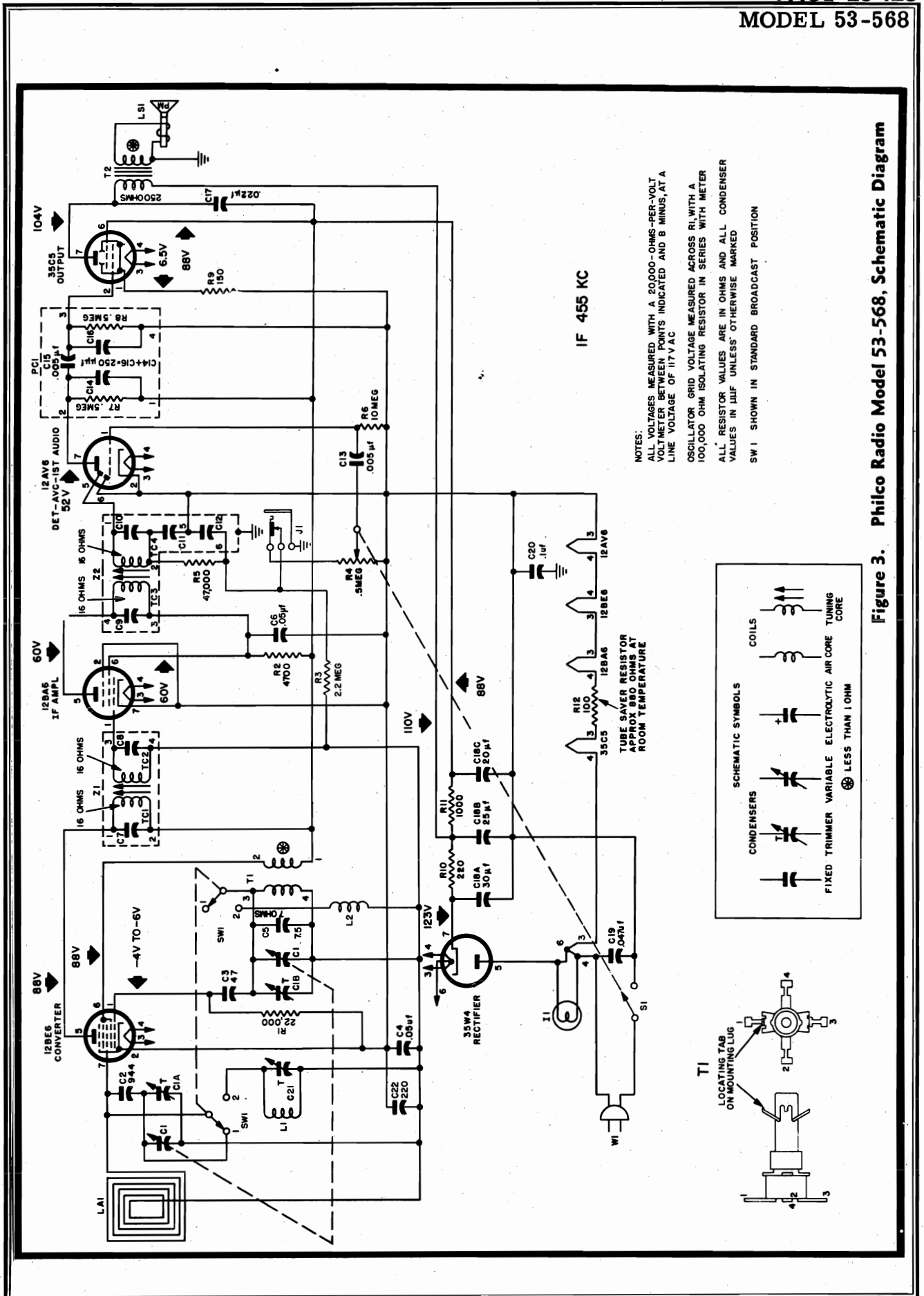
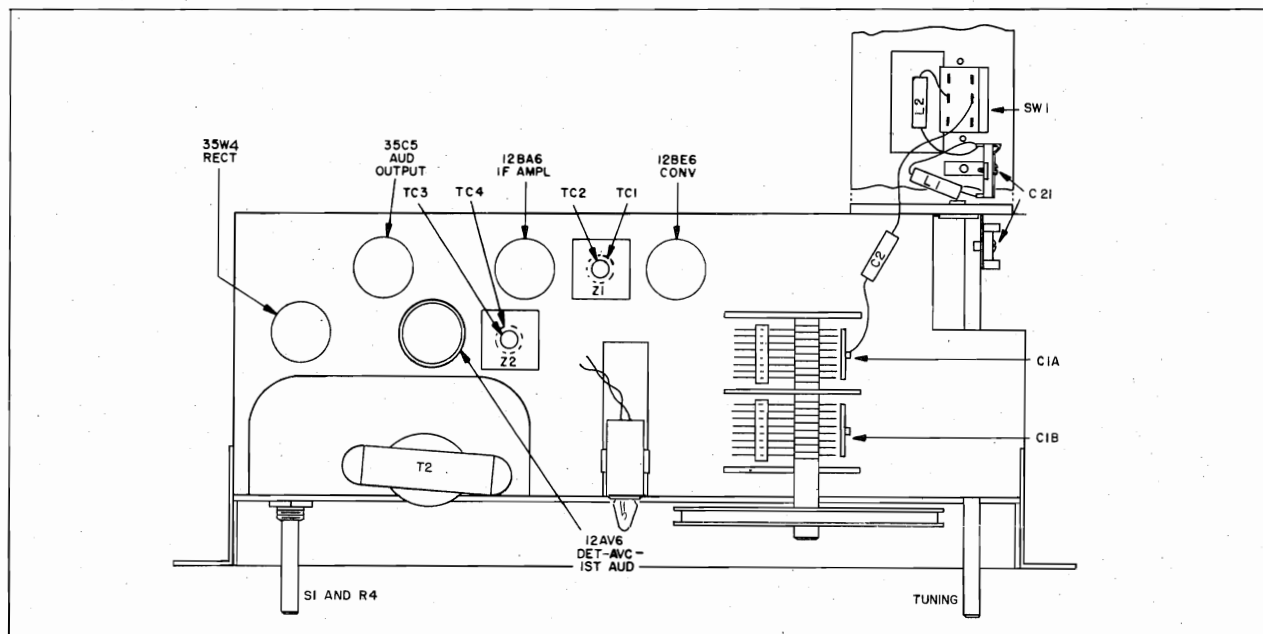

Figure 3. Philco Radio Model 53-568, Schematic Diagram



TP2-3196

Figure 4. Top View, Showing Trimmer Locations.

PARTS LIST

NOTE: Part numbers identified by an asterisk (*) are general replacement items. These numbers may not be identical with those on factory parts. Also, the electrical values of some replacement items may differ from the values indicated in the schematic diagram and parts list. The values substituted in any case are so chosen that the operation will be either unchanged or improved. When ordering replacements, use only the "Service Part No."

Reference Symbol	Description	Service Part No.
C1	Condenser, tuning gang	31-2751-15
C1A	Condenser, antenna trimmer	Part of C1
C1B	Condenser, osc. trimmer	Part of C1
C2	Condenser, aerial series tracker, 944 μ f.	30-1220-65
C3	Condenser, oscillator grid, 47 μ f.	30-1230-4
C4	Condenser, a-v-c by-pass, .05 μ f.	30-4650-45
C5	Condenser, drift compensation, 7.5 μ f.	30-1224-83
C6	Condenser, screen by-pass, .05 μ f.	30-4650-45
C7	Condenser, i-f tuning	Part of Z1
C8	Condenser, i-f tuning	Part of Z1
C9	Condenser, i-f tuning	Part of Z2
C10	Condenser, i-f tuning	Part of Z2
C11	Condenser, detector filtering	Part of Z2
C12	Condenser, detector filtering	Part of Z2
C13	Condenser, audio coupling, .005 μ f.	30-1238-1
C14	Condenser, plate by-pass	Part of PC1
C15	Condenser, audio coupling, .005 μ f.	Part of PC1
C16	Condenser, compensating	Part of PC1
C17	Condenser, tone compensation, .022 μ f.	30-4650
C18	Condenser, electrolytic, 3-section	30-2753
C18A	Condenser, filter, 30 μ f., 150v	Part of C18
C18B	Condenser, filter, 25 μ f., 150v	Part of C18
C18C	Condenser, filter, 20 μ f., 150v	Part of C18
C19	Condenser, line by-pass, .05 μ f.	30-4650-45
C20	Condenser, B- to chassis, .1 μ f.	30-4650-47*
C21	Condenser, trimmer, special services	31-6473-29
C22	Condenser, r-f by-pass	60-10225417
I1	Lamp, pilot	34-2068
J1	Bracket and socket assembly, phono	76-8330
L1	Coil, antenna, special services	32-4561-3
L2	Coil, oscillator shunt	32-4562-2
LA1	Loop, antenna	76-7718
LS1	Speaker, p-m	36-1641-1
PC1	Printed circuit	30-6001
R1	Resistor, oscillator grid, 22,000 ohms	66-3228340*
R2	Resistor, i-f screen dropping, 4700 ohms	66-2478340*
R3	Resistor, a-v-c filter, 2.2 megohms	66-5228340*
R4	Resistor, volume control, .5 megohm	33-5566-41
R5	Resistor, diode load, 47,000 ohms	66-3478340*

Reference Symbol	Description	Service Part No.
R6	Resistor, grid return, 10 megohms	66-6108340*
R7	Resistor, plate load, 500,000 ohms	Part of PC1
R8	Resistor, grid return, 500,000 ohms	Part of PC1
R9	Resistor, cathode bias, 150 ohms	66-1158340*
R10	Resistor, B plus filter, 220 ohms	66-1224340*
R11	Resistor, B plus filter, 1000 ohms	66-2108340*
R12	Resistor, tube saver, 100 ohms	33-1343-3
S1	Switch, off-on	Part of R4
SW1	Switch, broadcast-special services	42-1796-2
T1	Transformer, oscillator	32-4453-6
T2	Transformer, output	32-8384-2*
W1	Line cord	L-2183*
Z1	Transformer, 1st i-f	32-4161A
Z2	Transformer, 2nd i-f	32-4240A

MISCELLANEOUS

Description	Service Part No.
Cabinet, gray	10969
Cabinet back-and-loop assembly	76-7705
Cabinet back	54-6038
Dial scale	54-5173
Backplate, dial	28-9110
Clip, scale mounting (4 required)	1W60211FE7
Knob (2 required)	54-6034
Drive cord (25-foot spool)	45-8750
Pointer, dial	56-5630-55FCP
Rail assembly, pointer	76-8202
Shaft, tuning	56-9807
Socket assembly, pilot lamp	27-6233-6
Bracket and clip, pilot lamp	76-8272
Socket, 7-pin miniature (4 required)	27-6265
Socket (12AV6)	27-6203-14
Shield, tube	56-5629FA3
Spring	56-2617
Spring, retaining	28-8610

SERVICE HINTS

REMOVING THE CHASSIS FROM THE CABINET

To remove the chassis from the cabinet, first remove the station selector knob, volume control knob, and, at the bottom-center of the dial scale, remove the dial scale retaining screw. A flat object (knife blade) placed under the bottom edge will assist in prying the scale out of the cabinet. Pull to remove the pointer from the tuning gang shaft. Remove the screws from the cabinet back, and pull the back away from the back of the cabinet (use care to prevent breaking the leads from the loop aerial) far enough to reach in and remove the pilot lamp and socket from the retaining clip. Unsolder the output transformer leads from the speaker. Then remove the chassis mounting screws from beneath the cabinet, and remove the chassis.

REMOVING THE SUBBASE

After removing the chassis from the cabinet, remove the subbase, using the following procedure.

1. Remove the output transformer and dial light connections by pulling the jacks from the pins on the subbase.
2. Unsolder the volume control and a-c switch leads, and unsolder and remove the loop aerial.
3. Spring the Special Services switch bracket off the tuning shaft.
4. At the rear of the panel, bend the hold down tabs out flush with the subbase, and remove.

PARTS REPLACEMENT

Whenever possible, replace all components and leads from the top side of the chassis. In cases where this is not possible, the components must be unsoldered when removed from the bottom. Use only a light-weight low-wattage iron of approximately 22.5 to 25 watts, and always use a low-melting-point solder. Extreme caution must be used to prevent solder from dropping or splashing, and to avoid lifting of the printed wiring foil. Use only the tip of the soldering iron at the solder point whenever heat is being applied. Hold the subbase in one hand while applying heat to the solder point and throw the solder off, with a downward thrust, as soon as it starts to melt. When the solder is removed, the part to be repaired or replaced can be lifted from its location. Insert the new part and secure it with just a drop of solder at each point.

REPLACING TUBE SOCKETS AND I-F TRANSFORMERS

To replace tube sockets and i-f transformers, follow the procedure given above for removing solder. Then use a sharp knife to sever the remaining thin bond of solder at the connections. With the solder removed, the part can be backed out of the slots. Before inserting the repaired or new part, clean all connections at the unsoldered lugs. Use caution when reinserting parts through the subbase slots, so that the foil is not lifted. When soldering is complete apply an electrical varnish to all repaired areas.

ALIGNMENT PROCEDURE

RADIO CONTROLS—Set volume control to maximum. Set tuning control and band switch, SW1, as indicated in chart.

OUTPUT METER—Connect across voice-coil terminals.

SIGNAL GENERATOR—Connect generator and set frequency as indicated in chart. Use modulated output.

OUTPUT LEVEL—During alignment, adjust signal-generator output to hold output-meter reading below 1.25 volts.

STEP	SIGNAL GENERATOR		RADIO			ADJUST
	CONNECTION TO RADIO	DIAL SETTING	DIAL SETTING	BAND SWITCH SETTING	SPECIAL INSTRUCTIONS	
1	Ground lead to B-; output lead through a .1- μ f. condenser to grid (pin 7) of 12BE6.	455 kc.	Tuning gang fully open	Broadcast	Adjust tuning cores, in order given, for maximum output. TC1 and TC3 are located at top of transformers.	TC4—2nd i-f sec. TC3—2nd i-f pri. TC2—1st i-f sec. TC1—1st i-f pri.
2	Radiating loop (See note below).	1620 kc.	*1620 kc.	Broadcast	Adjust trimmer for maximum output.	C1-B—osc.
3	Same as step 2.	1500 kc.	1500 kc.	Broadcast	Adjust trimmer for maximum output.	C1-A—aerial (broadcast)
4	Same as step 2.	3200 kc.	3200 kc.	Special Services	Adjust trimmer for maximum output.	C21—aerial (special services).

NOTE: Make up a 6—8 turn, 6-inch-diameter loop from insulated wire, connect to signal-generator leads, and place near radio loop. The 1620-kc. index mark is located on the pointer rail, to the extreme right side as viewed from the front.

* For proper adjustment of the oscillator trimmer, fully open the tuning gang and insert a .006-inch non-metallic shim between the heel of the rotor and the top of the stator plates. Close the tuning gang sufficiently to hold the shim in place, and then remove the shim without disturbing the gang setting.

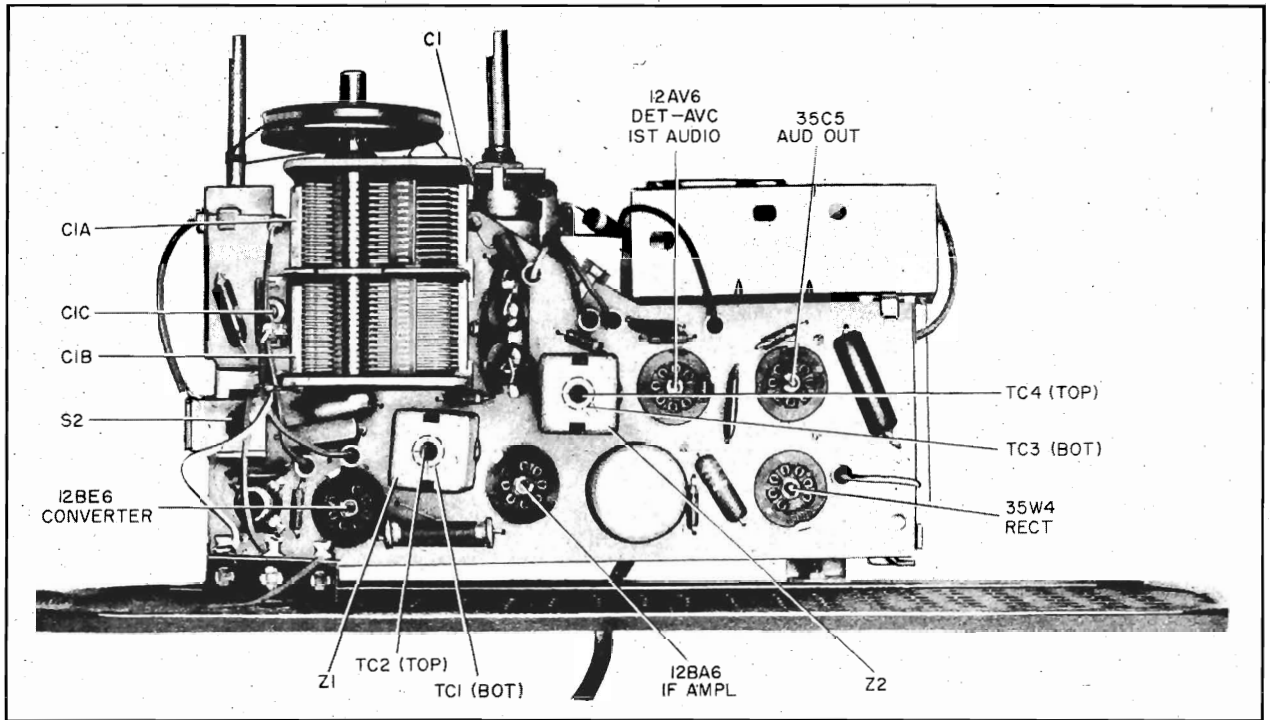

TP3-679

Figure 2. Top View, Showing Trimmer Locations

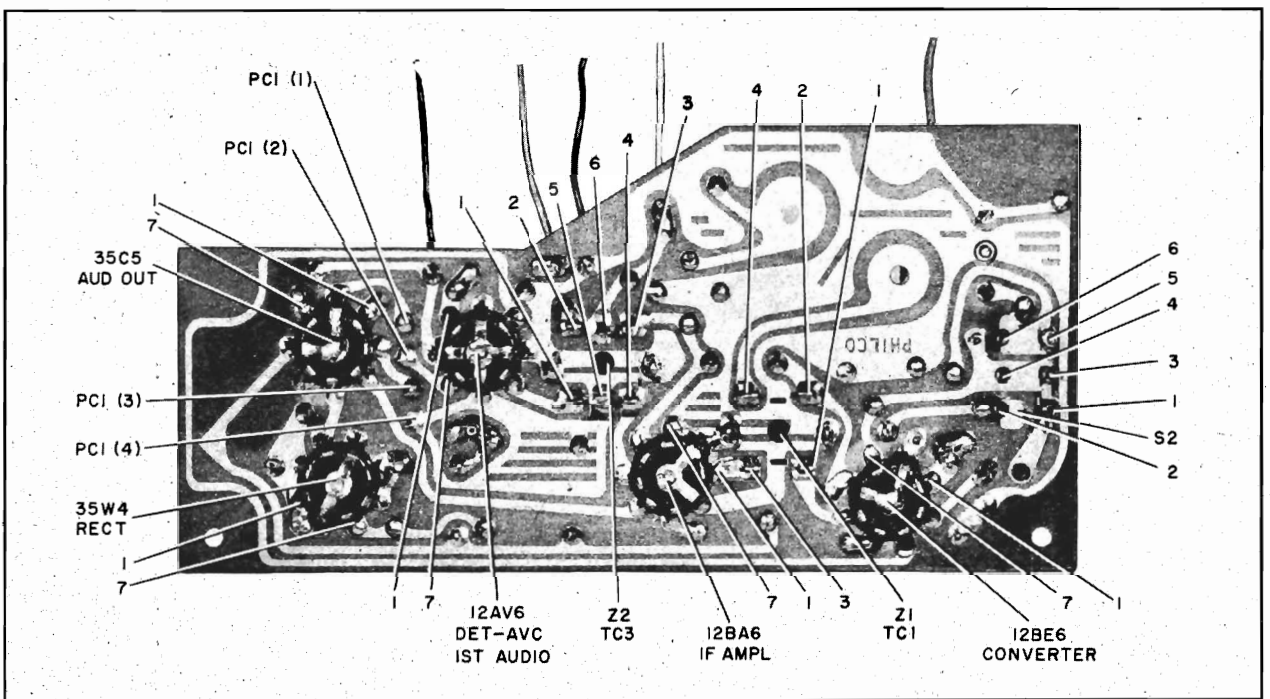

TP3-678

Figure 3. Base View, Showing Printed Wiring Circuit

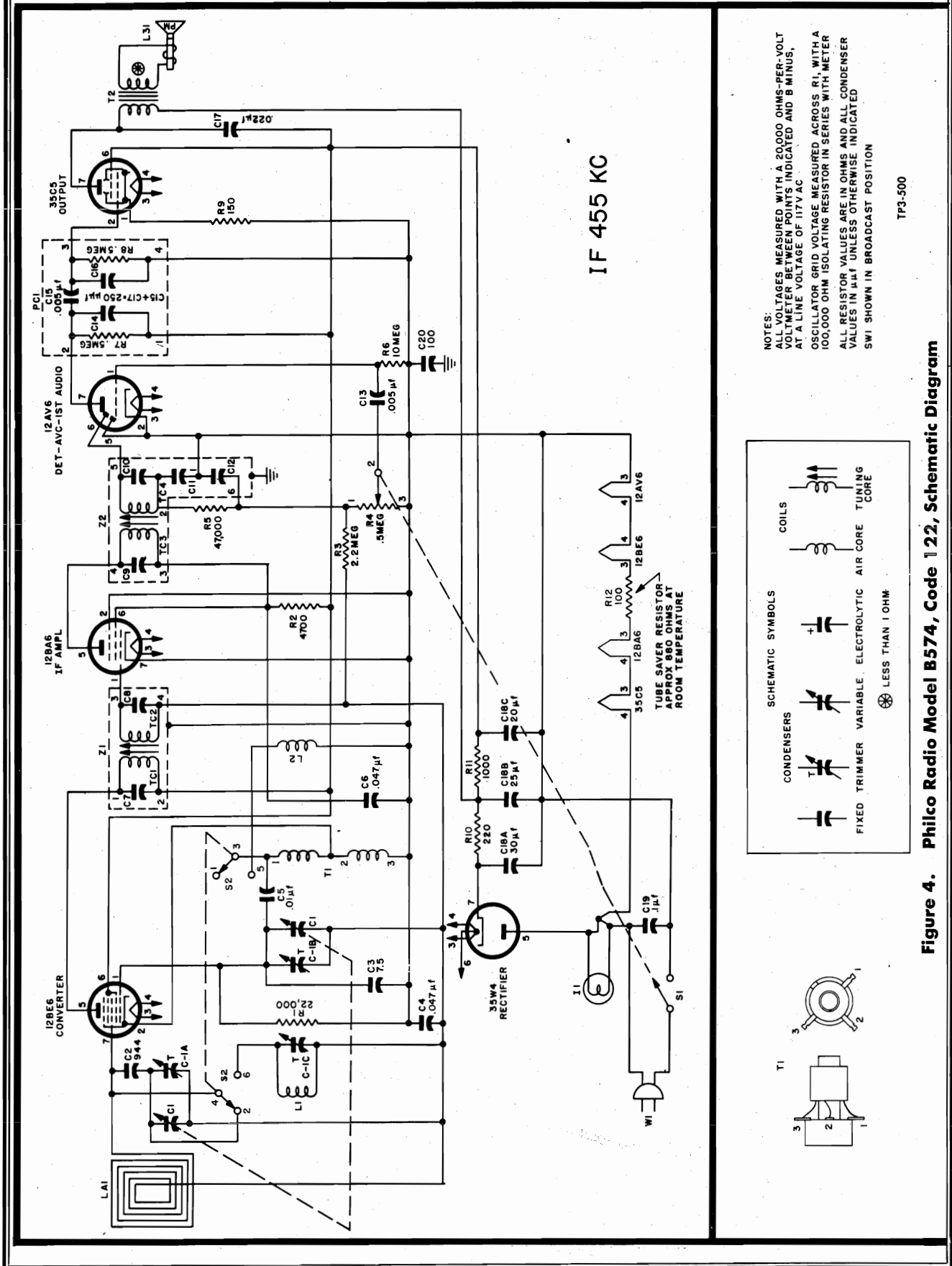

NOTES:
 ALL VOLTAGES MEASURED WITH A 20,000 OHMS-PER-VOLT VOLTMETER BETWEEN POINTS INDICATED AND B MINUS, AT A LINE VOLTAGE OF 117V AC.
 OSCILLATOR GRID VOLTAGE MEASURED ACROSS R1, WITH A 100,000 OHM ISOLATING RESISTOR IN SERIES WITH METER.
 ALL RESISTOR VALUES ARE IN OHMS AND ALL CONDENSER VALUES IN μF UNLESS OTHERWISE INDICATED.
 SW1 SHOWN IN BROADCAST POSITION.

TP3-500

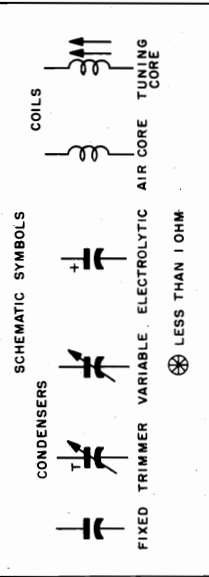
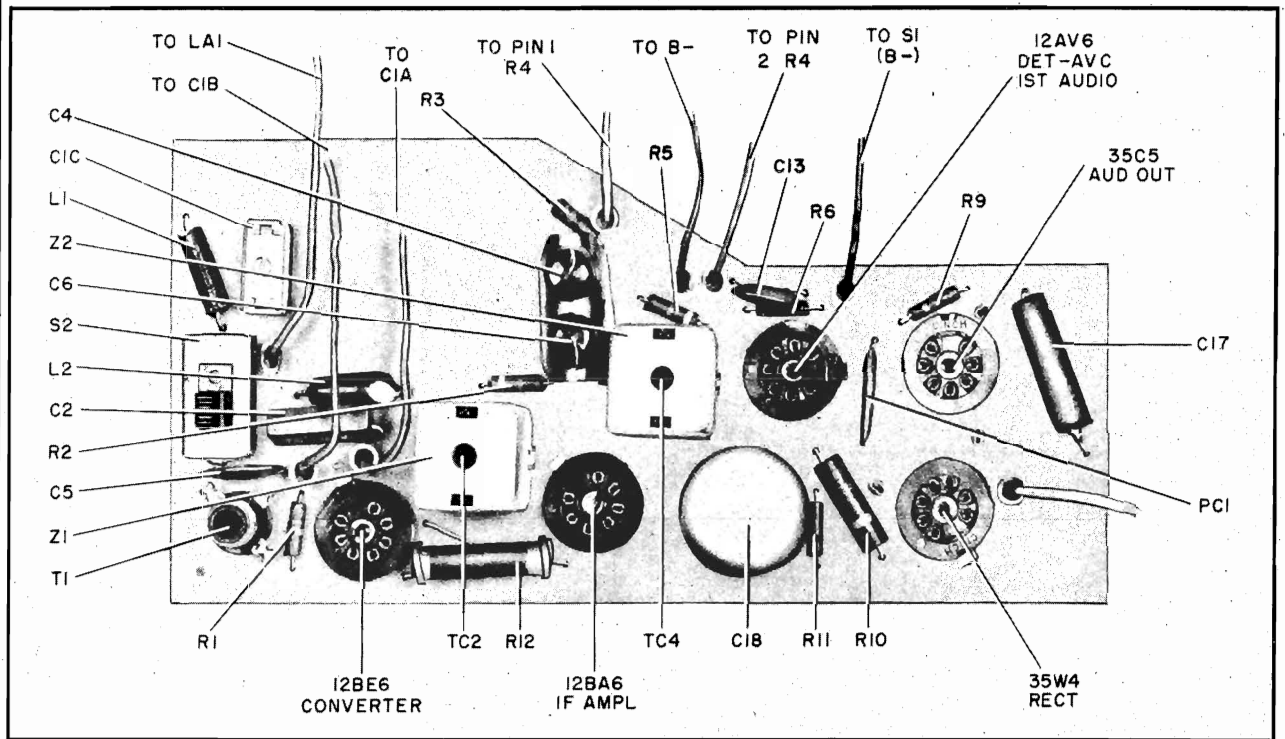
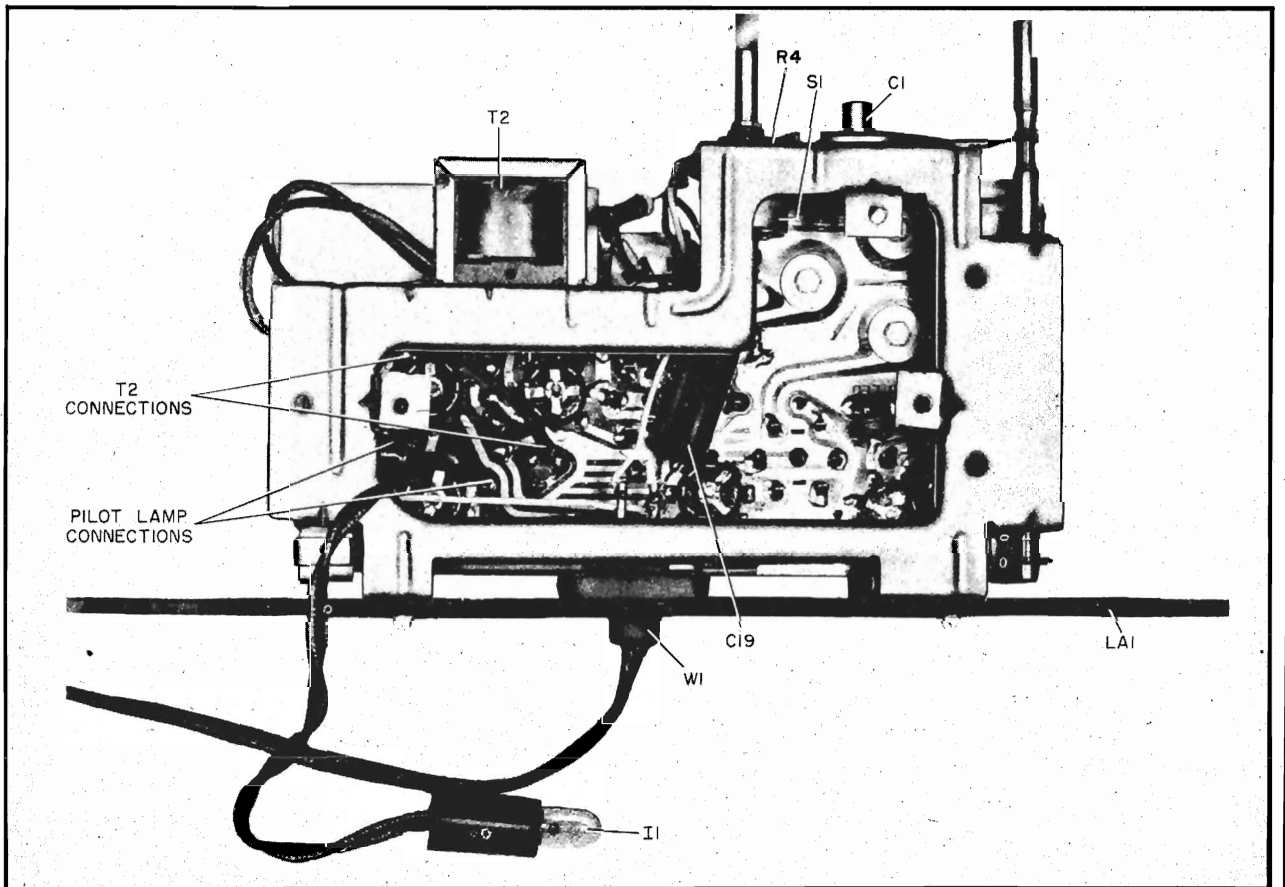

Figure 4. Philco Radio Model B574, Code 122, Schematic Diagram



TP3-681

Figure 5. Top View, Showing Parts Placement



TP3-680

Figure 6. Bottom View, Showing Parts Placement

PARTS LIST

NOTE: Part numbers identified by an asterisk (*) are general replacement items. These numbers may not be identical with those on factory parts. Also, the electrical values of some replacement items may differ from the values indicated in the schematic diagram and parts list. The values substituted in any case are so chosen that the operation will be unchanged. When ordering replacements, use only the "Service Part No."

Reference Symbol	Description	Service Part No.	Reference Symbol	Description	Service Part No.
C1	Condenser, tuning gang	31-2751-16	R5	Resistor, diode load, 47,00 ohms	66-3478340*
C1A	Condenser, aerial trimmer	Part of C1	R6	Resistor, grid return, 10 megohms	66-6108340*
C1B	Condenser, oscillator trimmer	Part of C1	R7	Resistor, plate load, 500,000 ohms	Part of PC1
C1C	Condenser, trimmer, Special Services	31-6502-4	R8	Resistor, grid return, 500,000 ohms	Part of PC1
C2	Condenser, antenna series tracker, 944 μ f.	30-1220-65	R9	Resistor, cathode bias, 150 ohms	66-1158340*
C3	Condenser, drift compensation, 7.5 μ f.	30-1224-83	R10	Resistor, B plus filter, 220 ohms	66-1224340*
C4	Condenser, a-v-c by-pass, .047 μ f.	30-4650-45	R11	Resistor, B plus filter, 1000 ohms	66-2108340*
C5	Condenser, oscillator grid, .01 μ f.	30-1238-2	R12	Resistor, tube saver, 100 ohms	33-1343-3
C6	Condenser, screen by-pass, .05 μ f.	30-4650-45	S1	Switch, off-on	Part of R4
C7	Condenser, i-f tuning	Part of Z1	S2	Switch, Broadcast-Special Services	42-1796-4
C8	Condenser, i-f tuning	Part of Z1	T1	Transformer, oscillator	32-4582
C9	Condenser, i-f tuning	Part of Z2	T2	Transformer, output	32-8384-5
C10	Condenser, i-f tuning	Part of Z2	W1	Line cord	L-2183*
C11	Condenser, detector filtering	Part of Z2	Z1	Transformer, 1st i-f	32-4583
C12	Condenser, detector filtering	Part of Z2	Z2	Transformer, 2nd i-f	32-4584
C13	Condenser, audio coupling, .005 μ f.	30-1238-1	MISCELLANEOUS		
C14	Condenser, plate by-pass	Part of PC1	Description		
C15	Condenser, audio coupling, .005 μ f.	Part of PC1	Service Part No.		
C16	Condenser, compensating	Part of PC1	Cabinet, spruce	10926-19	
C17	Condenser, tone compensation, .022 μ f.	30-4650-43	Cabinet, tangerine	10926-23	
C18	Condenser, electrolytic, 3-section	30-2583-1	Back-and-loop assembly	76-8362	
C18A	Condenser, filter, 30 μ f., 150v	Part of C18	Connector, interlock, male	27-6240-6	
C18B	Condenser, filter, 25 μ f., 150v	Part of C18	Dial backplate, spruce	54-4972-2	
C18C	Condenser, filter, 20 μ f., 150v	Part of C18	Dial backplate, tangerine	54-4972	
C19	Condenser, line by-pass, .05 μ f.	30-4650-47	Dial scale	54-5147-3	
C20	Condenser, B minus to chassis, 100 μ f.	62-110009001	Drive cord, 25-foot spool	45-8750	
I1	Lamp, pilot	34-2068	Knob	54-4773-3	
L1	Coil, aerial, Special Services	32-4561-3	Pointer	28-9502	
L2	Coil, oscillator shunt	32-4562-2	Shaft, tuning	28-9312	
LA1	Loop, part of cabinet back	76-8362	Bracket, switch operating	28-9313	
LS1	Speaker, p-m	36-1627-21	Socket assembly, pilot lamp	41-4176-2	
R1	Resistor, oscillator grid, 22,000 ohms	66-3228340*	Shield, pilot lamp	54-8806	
R2	Resistor, i-f screen dropping, 4700 ohms	66-2748340*	Socket, 7-pin miniature	27-6296-5	
R3	Resistor, a-v-c filter, 2.2 megohms	66-5228340*	Socket, 7-pin miniature, 12AV6	27-6296-4	
R4	Resistor, volume control, .5 megohm	33-5566-41	Shield, tube	56-5629-12	
			Printed wiring panel (less components)	54-6058	

SPECIFICATIONS

CABINET.....	Wood console, mahogany
CIRCUIT.....	Five-tube superheterodyne (plus rectifier)
FREQUENCY RANGE	
Broadcast.....	540 kc. to 1620 kc.
Special Services.....	1700 kc. to 3400 kc.
AUDIO OUTPUT.....	4.5 watts
OPERATING VOLTAGE.....	105—120 volts, a.c.
POWER CONSUMPTION.....	.80 watts
ANTENNA.....	Built-in, low-impedance loop
INTERMEDIATE FREQUENCY.....	455 kc.
PHILCO TUBES.....	6BJ6 r-f ampl; 6BE6 converter, osc., phono preampl; 6BJ6 i-f ampl; 6AV6 detector, a.v.c., 1st audio; 6AQ5 output; 6X4 rectifier



MODEL B1754

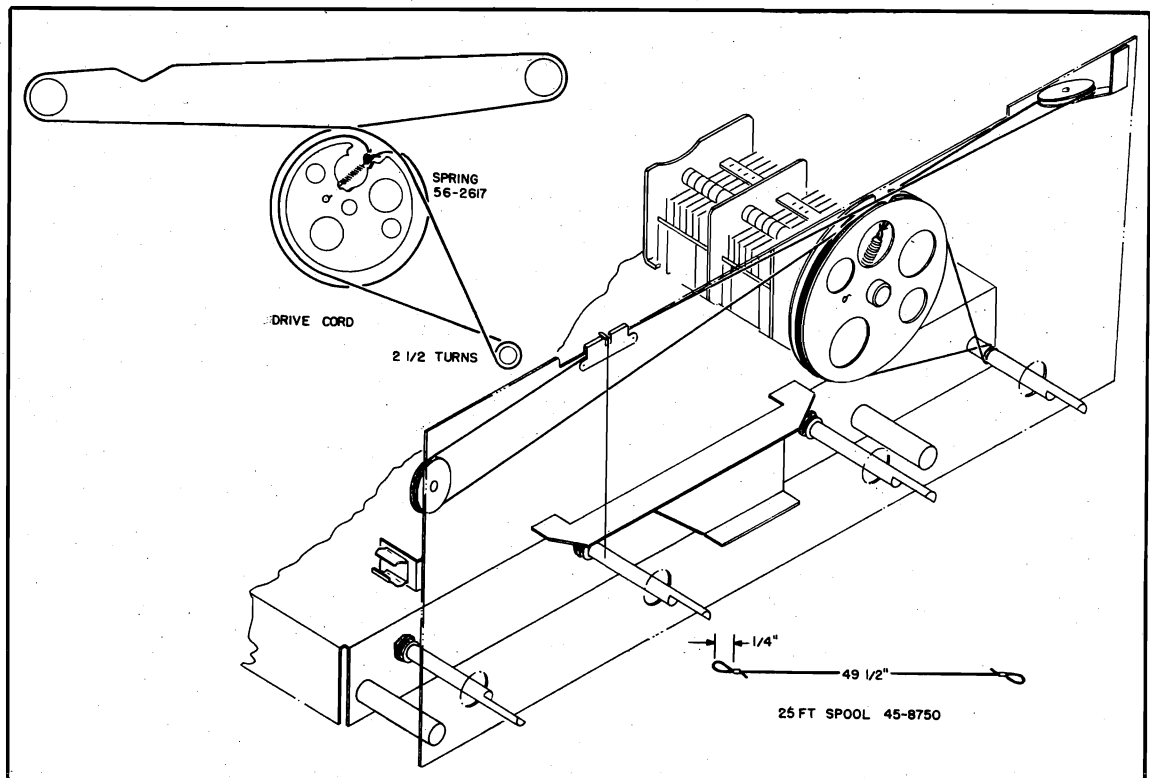

Figure 1. Drive-Cord Installation Details

TP2-3243

PR-2554

ALIGNMENT PROCEDURE

GENERAL

RADIO CONTROLS—Set volume control for maximum output, and set tuning control as indicated in the alignment chart. Set band switch to broadcast position for first 5 steps, then to special services position for steps 6 and 7.

OUTPUT INDICATOR—Connect output indicator (either an oscilloscope or a 1000-ohms-per-volt, a-c voltmeter) across voice-coil terminals.

SIGNAL GENERATOR—Use an AM r-f generator, connected as indicated in the alignment chart.

OUTPUT LEVEL—During alignment, attenuate signal-generator output to maintain output indication below 1 volt.

DIAL POINTER—Before the alignment is started, the dial pointer should be set to coincide with the dial scale mark to the left of "55" when the tuning gang is fully meshed.

ALIGNMENT CHART

STEP	SIGNAL GENERATOR		RADIO		ADJUST
	CONNECTION TO RADIO	DIAL SETTING	DIAL SETTING	SPECIAL INSTRUCTIONS	
1	Ground lead to chassis. Output lead through a .01- μ f. condenser to pin 7 (mixer grid) of 6BE6, converter.	455 kc.	Tuning gang fully open.	Adjust, in order given in next column, for maximum output.	TC6—2nd i-f sec. TC3—1st i-f pri. TC5—2nd i-f pri. TC4—1st i-f sec.
2	Radiating loop. See Note 1 below.	1620 kc.	1620 kc. See Note 2 below.	Adjust for maximum output.	CLC—osc. trimmer
3	Same as step 2.	1520 kc.	Tune radio to generator signal.	Adjust for maximum output. (High-frequency adjustment).	CLB—mixer-grid trimmer C1A—r-f trimmer
4	Same as step 2.	580 kc.	Same as step 3.	Adjust for maximum output. (Low-frequency adjustment).	TC2—r-f transformer TC1—ant. transformer
5	Repeat steps 3 and 4 until no further improvement is obtained.				
6	Same as step 2.	3200 kc.	Same as step 3.	Adjust for maximum output.	C10—special services mixer-grid trimmer C4—special services r-f trimmer
7	Same as step 2.	1800 kc.	Same as step 3.	Adjust for maximum output.	C2—special services r-f padder

NOTE 1: Make up a 6-8 turn, 6-inch-diameter loop from insulated wire; connect to signal-generator leads and place about 1 foot from radio loop antenna. The position of the radio loop with respect to the chassis should be approximately the same as when both are mounted in the cabinet.

NOTE 2: To set the tuning gang to 1620 kc., place a piece of 6-mil flat shim stock beneath the heel of the rotor, and turn the rotor until it holds the shim firmly in place. Then remove the shim.

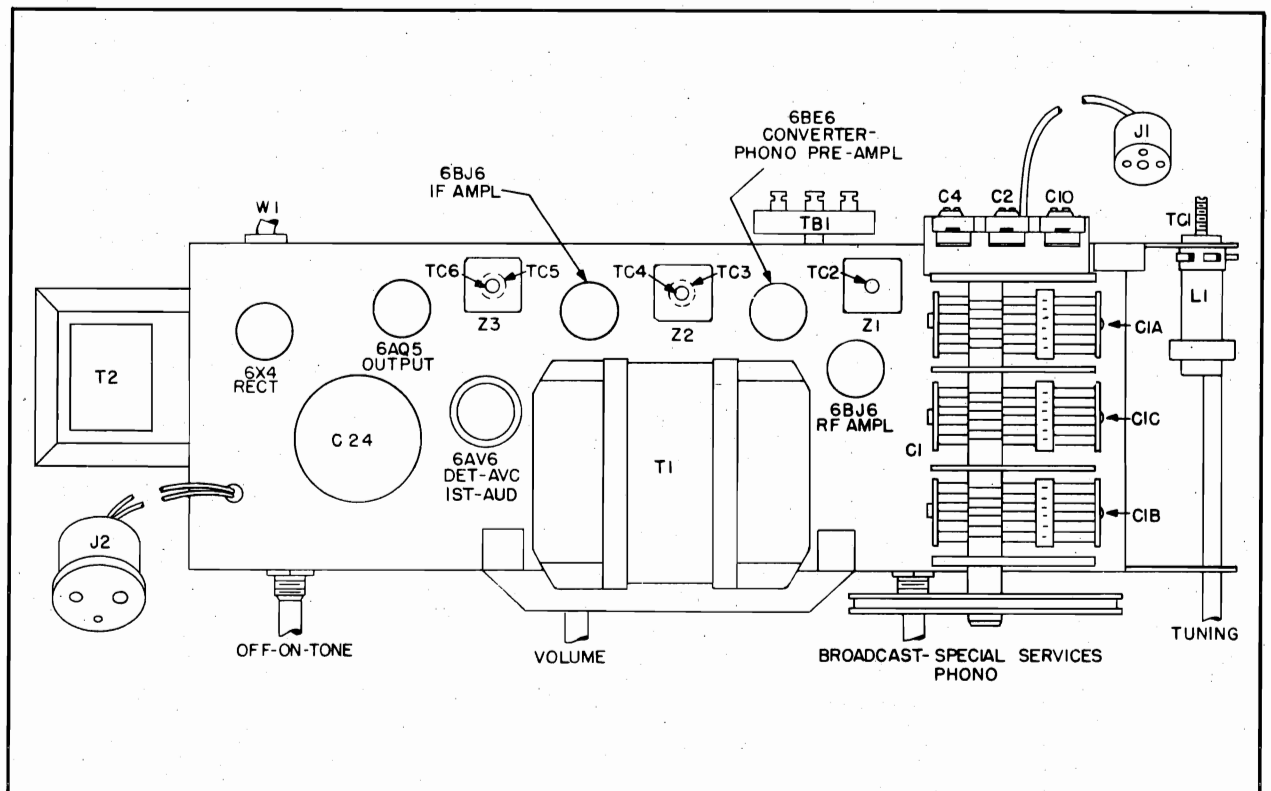

TP3-837

Figure 2. Top View, Showing Tuning Adjustments

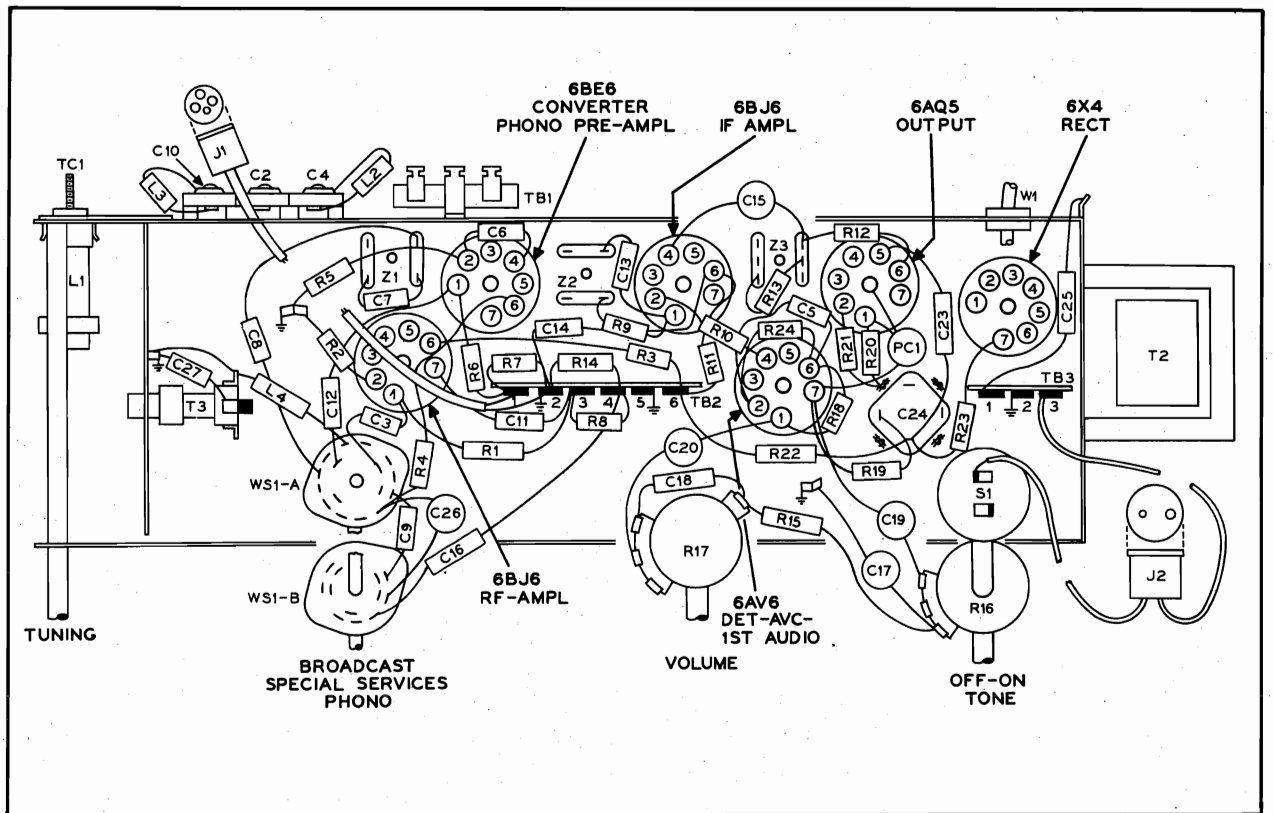

TP3-838

Figure 3. Base View, Showing Parts Placement

MODEL B1754

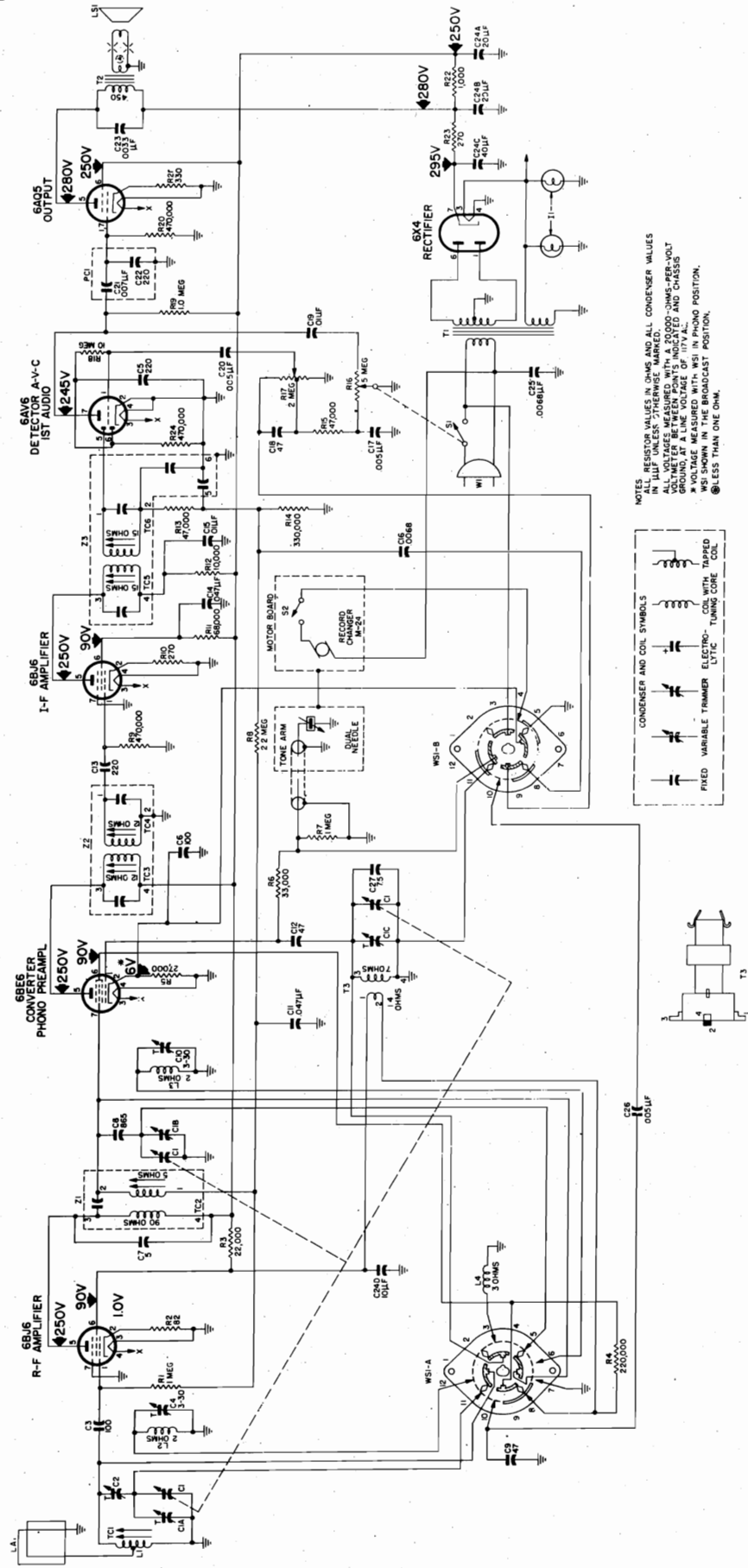

NOTES
 ALL RESISTOR VALUES IN OHMS AND ALL CONDENSER VALUES IN μ F UNLESS OTHERWISE MARKED.
 VOLTAGE RATINGS ARE SHOWN ON OHMS PER VOLT VOLTMETER BETWEEN POINTS INDICATED AND CHASSIS GROUND, AT A LINE VOLTAGE OF 117 V.A.
 WSI SHOWN IN THE BROADCAST POSITION.
 * LESS THAN ONE OHM.

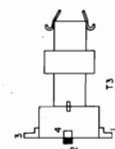

Figure 4. Philco Radio-Phonograph Model B1754, Schematic Diagram

PARTS LIST

NOTE: Part numbers identified by an asterisk (*) are general replacement items. These numbers may not be identical with those on factory parts. Also, the electrical values of some replacement items may differ from the values indicated in the schematic diagram and parts list. The values substituted in any case are so chosen that the operation will be unchanged. When ordering replacements, use only the "Service Part No."

Reference Symbol	Description	Service Part No.	Reference Symbol	Description	Service Part No.
C1	Condenser, tuning gang, 3-section	31-2771-3	R10	Resistor, cathode bias, 270 ohms	66-1275340*
C1A	Condenser, trimmer, antenna	Part of C1	R11	Resistor, screen dropping, 68,000 ohms	66-3688340*
C1B	Condenser, trimmer, r-f	Part of C1	R12	Resistor, plate dropping, 10,000 ohms	66-3108340*
C1C	Condenser, trimmer, oscillator	Part of C1	R13	Resistor, i-f filter, 47,000 ohms	66-3478340*
C2	Condenser, padder, special services r-f	Part of CA1	R14	Resistor, diode load, 330,000 ohms	66-4338340*
C3	Condenser, d-c blocking, 100 $\mu\mu\text{f}$.	62-110001001*	R15	Resistor, tone compensation (bass boost)	66-3478340*
C4	Condenser, trimmer, special services r-f	Part of CA1	R16	Resistor, tone control, 5 megohms	33-5566-48
C5	Condenser, r-f by-pass, 220 $\mu\mu\text{f}$.	62-122001001*	R17	Resistor, volume control, 2 megohms	33-5535-36
C6	Condenser, r-f by-pass, 100 $\mu\mu\text{f}$.	62-110001001*	R18	Resistor, grid leak, 10 megohms	66-6108340*
C7	Condenser, r-f by-pass, 5 $\mu\mu\text{f}$.	60-90505020	R19	Resistor, plate load, 1 megohm	66-5108340*
C8	Condenser, fixed padder, 865 $\mu\mu\text{f}$.	30-1220-72	R20	Resistor, grid leak, 470,000 ohms	66-4478340*
C9	Condenser, harmonic suppression, 47 $\mu\mu\text{f}$.	60-00475417	R21	Resistor, cathode bias, 330 ohms, 1 watt	66-1334340*
C10	Condenser, trimmer, special services mixer-grid	Part of CA1	R22	Resistor, B+ filter, 1000 ohms	66-2105340*
C11	Condenser, a-v-c by-pass, .047 μf .	30-4650-45*	R23	Resistor, B+ filter, 270 ohms	66-1275340*
C12	Condenser, oscillator coupling, 47 $\mu\mu\text{f}$.	60-00475417	R24	Resistor, diode load, 470,000 ohms	66-4478340*
C13	Condenser, i-f coupling, 220 $\mu\mu\text{f}$.	62-122001001*	S1	Switch, off-on	Part of R16
C14	Condenser, screen by-pass, .047 μf .	30-4650-45*	S2	Switch, off-on, phono motor	Part of M-24 Record Changer
C15	Condenser, plate by-pass, .01 μf .	30-1238-2*	T1	Transformer, power	32-8610
C16	Condenser, audio coupling, .0068 μf .	30-4650-57	T2	Transformer, output	32-8242-13
C17	Condenser, tone compensation (bass boost), .005 μf .	30-1238-1*	T3	Transformer, oscillator	32-4453-2
C18	Condenser, tone compensation, 47 $\mu\mu\text{f}$.	60-00475417	W1	Line cord	L-2183*
C19	Condenser, tone compensation (high cut) .01 μf .	30-1238-2*	WS1	Switch, band	42-1997
C20	Condenser, audio coupling, .005 μf .	30-1238-1*	Z1	Transformer, r-f	32-4399-7A
C21	Condenser, d-c blocking, .007 μf .	Part of PC1	Z2	Transformer, 1st i-f	32-4160A
C22	Condenser, r-f by-pass, 220 $\mu\mu\text{f}$.	Part of PC1	Z3	Transformer, 2nd i-f	32-4240A
C23	Condenser, tone compensation, .0033 μf .	30-4650-89*	MISCELLANEOUS		
C24	Condenser, electrolytic filter	30-2584-32	Description		Service Part No.
C24A	Condenser, filter, 20 μf .	Part of C24	Cabinet, mahogany		10985
C24B	Condenser, filter, 20 μf .	Part of C24	Back		54-8932
C24C	Condenser, filter, 40 μf .	Part of C24	Hinge, right hand (2)		56-9922
C24D	Condenser, filter, 10 μf .	Part of C24	Hinge, left hand (2)		56-9922-1
C25	Condenser, line by-pass, .0068 μf .	30-4650-57	Cabinet, blonde oak		10985-1
C26	Condenser, audio coupling (phono), .005 μf .	30-1238-1	Back		54-8932-1
C27	Condenser, fixed trimmer, 7.5 $\mu\mu\text{f}$.	30-1224-65	Hinge, right hand (2)		56-9922-2
CA1	Condenser assembly, trimmer	31-6477-17	Hinge, left hand (2)		56-9922-3
I1	Lamp assembly, pilot (2)	27-6233-4	Dome (4)		45-6190
J1	Connector, phono input	76-8262-1	Door pull (2)		56-7062-1
J2	Connector, phono a-c	76-8366	Bullet catch (2)		45-6002
L1	Coil, antenna	32-4413-2	Strike plate (2)		45-6003
L2	Coil, special services r-f	32-4561-5	Changer frame ass'y.		76-6600-2
L3	Coil, special services mixer grid	32-4561-5	Rail ass'y., r.h. (changer drawer)		76-6597
L4	Coil, oscillator shunt	32-4562-1	Rail ass'y., l.h. (changer drawer)		76-6258
LA1	Loop antenna	32-4394-13	Spring, changer mtg. (3)		56-7059FA9
LS1	Speaker (10")	36-1610-6	Spring, changer mtg. (3)		56-7059-1FCP
PC1	Printed circuit	30-1239-4	Sleeve, changer mtg. (3)		54-7798
R1	Resistor, r-f a-v-c, 1 megohm	66-5108340*	Pull knob, changer drawer		56-8496
R2	Resistor, cathode bias, 82 ohms	66-0828340*	Frame ass'y.		45-9790
R3	Resistor, screen dropping, 22,000 ohms	66-3225340*	Dial backplate ass'y.		76-8321
R4	Resistor, plate load, preampl., 220,000 ohms	66-4228340	Dial scale		54-5184
R5	Resistor, cathode bias, 27,000 ohms	66-3278340*	Clip, scale		56-4756FE11
R6	Resistor, oscillator grid leak, 33,000 ohms	66-3338340*	Knob (3)		54-4718-20
R7	Resistor, load (phono), 1 megohm	66-5108340*	Knob		54-4718-21
R8	Resistor, a-v-c load, 2.2 megohms	66-5228340*	Spring, shaft retaining		28-8610
R9	Resistor, grid leak, 470,000 ohms	66-4478340*	Pointer		56-5630-57
			Socket (5)		27-6275
			Socket (6AV6)		27-6203-14
			Rubber mount, gang mounting		27-4596
			Tube shield		56-5629FA3

MODEL B652

SPECIFICATIONS

CABINET	Plastic portable
CIRCUIT	Four-tube superheterodyne (plus selenium rectifier)
AUDIO OUTPUT	
A-C or d-c operation	160 milliwatts
Battery operation	85 milliwatts
OPERATING VOLTAGE	
	117 volts, a.c. or d.c.
	1.5-volt "A" battery and 75-volt "B" battery
POWER CONSUMPTION	
A-C or d-c operation	11 watts
Battery operation	10 ma. from 75-volt "B" battery (7 ma.: battery-saver operation)
	260 ma. from 1.5-volt "A" battery
ANTENNA	
	Magnecor high-impedance loop with provision for external antenna
INTERMEDIATE FREQUENCY	
	455 kc.
PHILCO TUBES	
	1R5 converter, 1U4 i-f amplifier, 1U5 detector-a.v.c. 1st audio, 3V4 output
BATTERY TYPE	
	P144 "B" battery
	P77 "A" battery

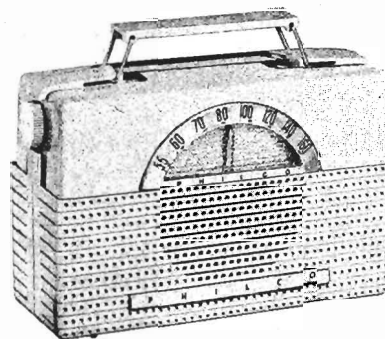

MODEL B652

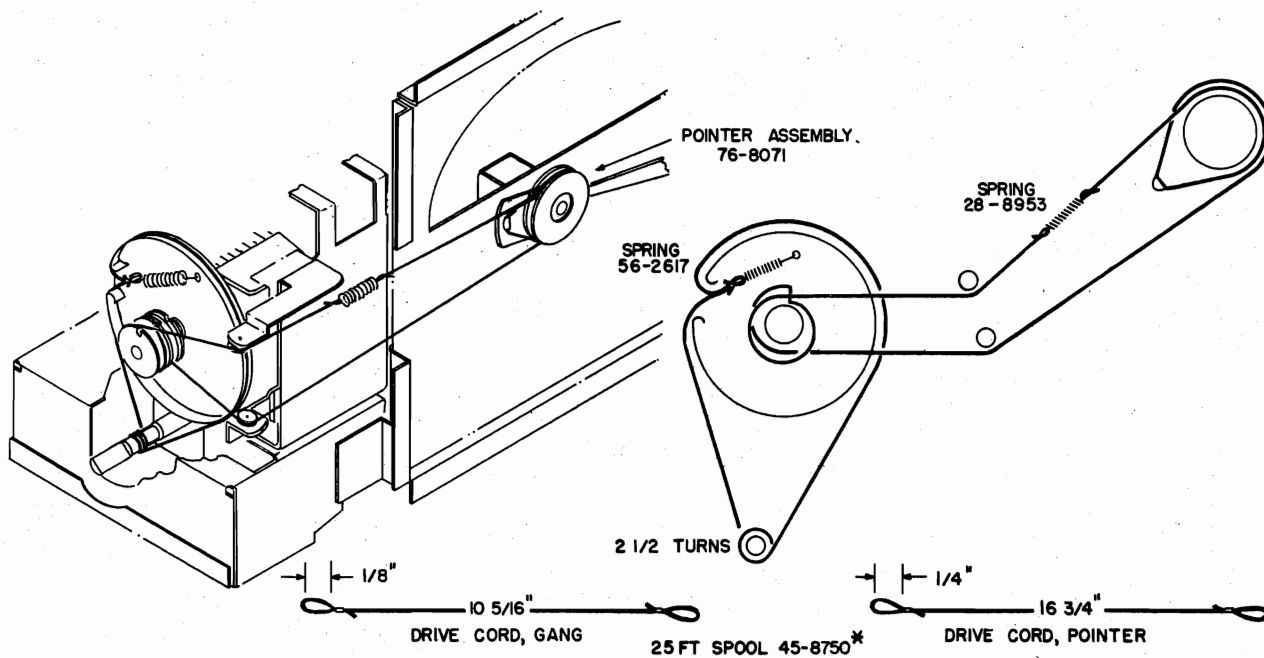

Figure 1. Dial-Cord Stringing Arrangement

PR-2538

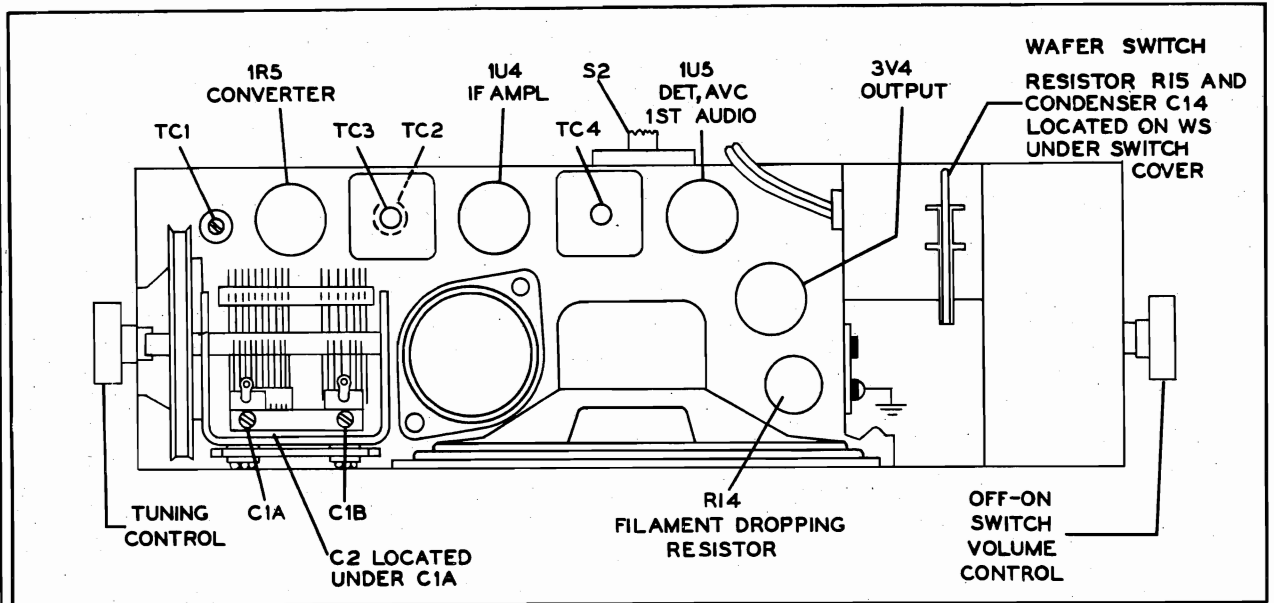

Figure 2. Top View, Showing Tuning Adjustments

TP2-3168

ALIGNMENT PROCEDURE

GENERAL—Allow the set and the test equipment to warm up for fifteen minutes before starting the alignment procedure.

DIAL POINTER—Before proceeding with the alignment, the dial pointer should be set to coincide with the index mark to the extreme left of the dial backplate when the tuning-condenser plates are fully meshed. See figure 4.

OUTPUT INDICATOR—Connect the output indicator (a 1000-ohm-per-volt, a-c voltmeter, or an oscilloscope) across the voice-coil terminals.

SIGNAL GENERATOR—Use an AM r-f signal gen-

erator. Connect the ground lead to B—, and connect the output lead as indicated in the alignment chart.

OUTPUT LEVEL—Attenuate the signal-generator output throughout the alignment so as to maintain the output level below .5 volt.

RADIO CONTROLS—Set the volume control to maximum. Set the tuning control as indicated in the alignment chart. During alignment of the radio, the batteries should be in the same position with respect to the chassis and the loop antenna as they normally are in the cabinet. It is recommended that a-c power be used when aligning the radio.

ALIGNMENT CHART

STEP	SIGNAL GENERATOR		RADIO		ADJUST
	CONNECTION TO RADIO	DIAL SETTING	DIAL SETTING	SPECIAL INSTRUCTIONS	
1	Connect signal generator through a .1- μ f. condenser to pin 6 (converter grid) of 1R5.	455 kc.	Tuning gang fully open.	Adjust for maximum output in order given.	TC4—2nd if sec. TC2—1st if pri. TC3—1st if sec.
2	Use radiating loop. (See NOTE 1 below.)	1620 kc.	1620 kc. (See NOTE 2 below.)	Adjust for maximum output.	C1B—osc. trimmer
3	Same as step 2.	1400 kc.	1400 kc. (See NOTE 2 below.)	Adjust for maximum output.	C1A—antenna trimmer
4	Same as step 2.	600 kc.	600 kc. (See NOTE 2 below.)	Adjust for maximum output. Rock tuning gang while making this adjustment.	TC1—osc. core
5	Repeat steps 2, 3, and 4 until no further improvement is obtained.				

NOTE 1. Use a 6-to-8-turn, 6-inch-diameter loop made up of insulated wire. Connect to generator terminals, and place about one foot from radio loop.

NOTE 2. The tuning condenser can be set to the proper frequency by turning it until the dial pointer coincides with the respective marks on the dial backplate. See figure 2.

MODEL B652

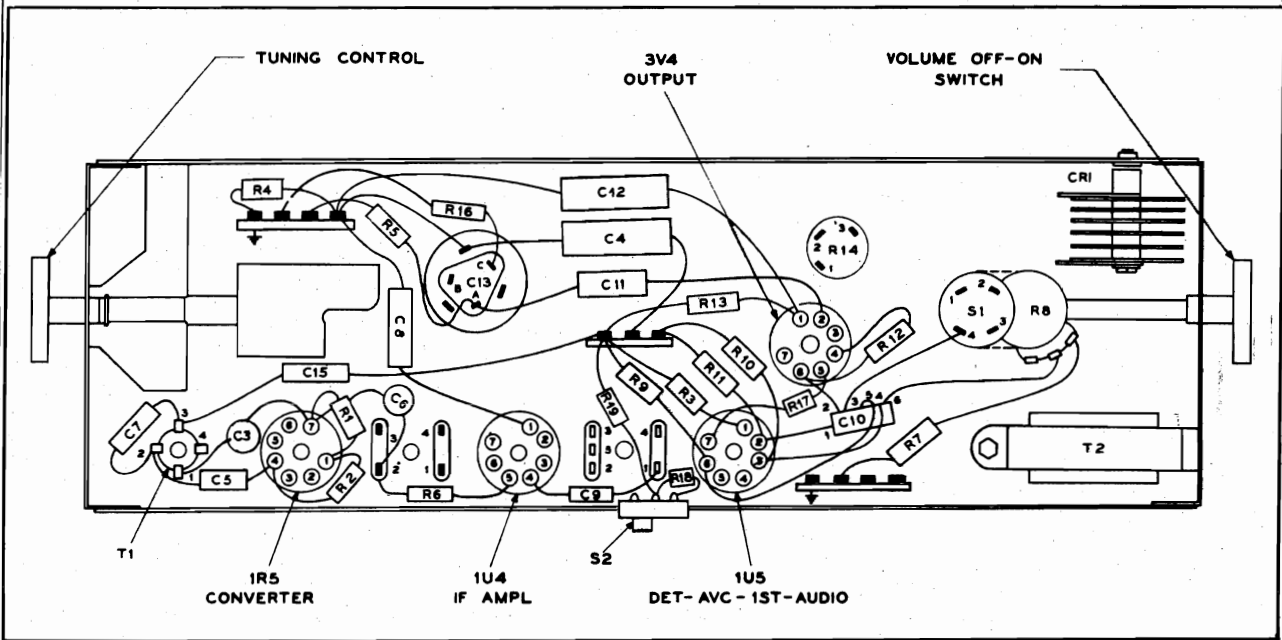

Figure 3. Base View, Showing Parts Placement

TP2-3167

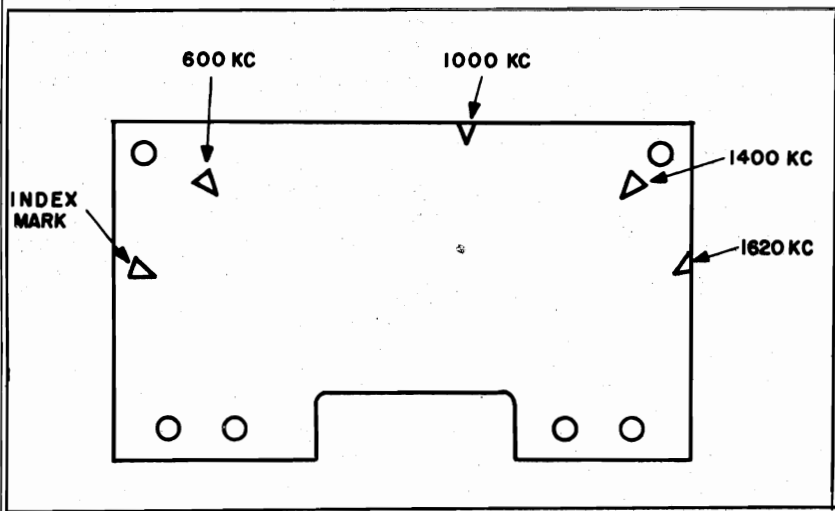
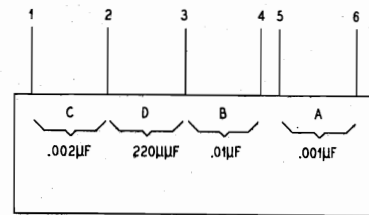
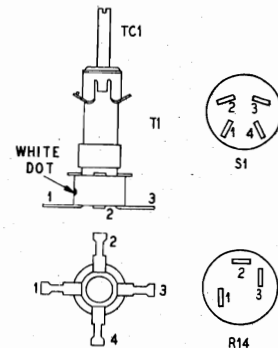

Figure 4. Dial Backplate, Showing Alignment Marks



* C10 FOUR SECTION CONDENSER

TUBE SOCKET VOLTAGES

B SUPPLY	1R5		1U4		1U5		3V4	
	RF PLATE PIN 2	OSC PLATE PIN 3	PLATE PIN 2	SCREEN PIN 3	PLATE PIN 2	SCREEN PIN 3	PLATE PIN 2	SCREEN PIN 3
PWR LINE (AC OR DC)	90	55	90	90	16	15	86	90
BATTERY	70	41	70	70	17	16	67	70

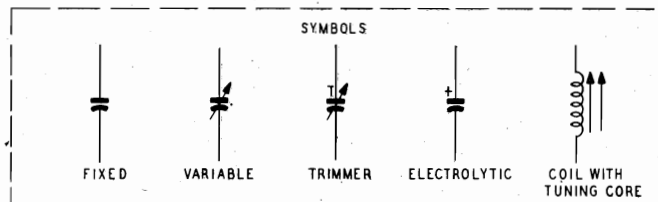

NOTES:
 ALL RESISTOR VALUES IN OHMS AND ALL CONDENSER VALUES IN µF UNLESS OTHERWISE MARKED.
 ⊕ LESS THAN 1 OHM
 ALL VOLTAGES SHOWN WERE MEASURED WITH A 20,000 OHMS-PER-VOLT METER FROM POINTS INDICATED TO B-

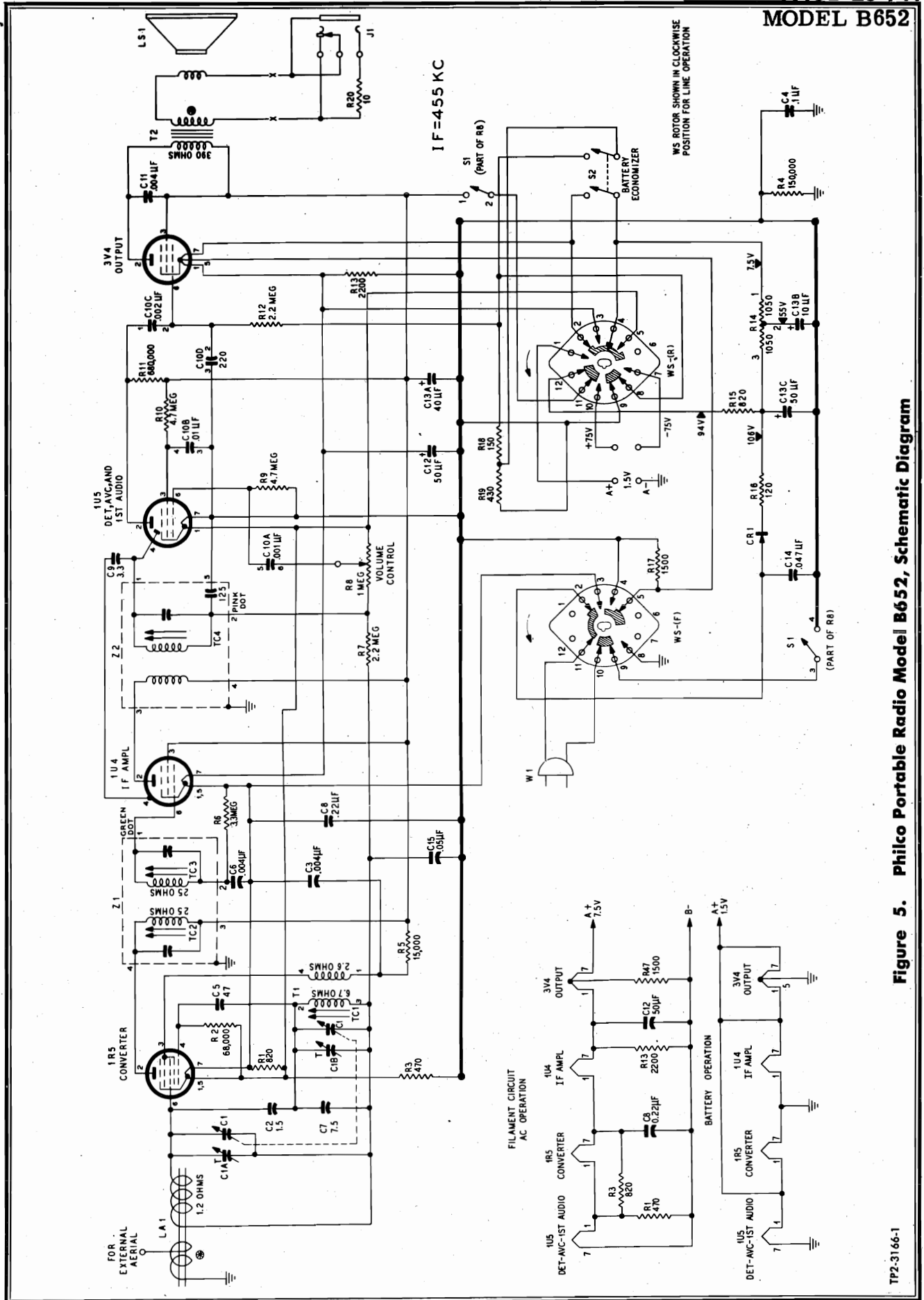

Figure 5. Philco Portable Radio Model B652, Schematic Diagram

MODEL B652

PARTS LIST

NOTE: Part numbers identified by an asterisk (*) are general replacement items. These numbers may not be identical with those on factory parts. Also, the electrical values of some replacement items may differ from the values indicated in the schematic diagram and parts list. The values substituted in any case are so chosen that the operation will be unchanged. When ordering replacements, use only the "Service Part No."

Reference Symbol	Description	Service Part No.
C1	Condenser, tuning gang	31-2735-4
C1A	Condenser, trimmer, antenna	Part of C1
C1B	Condenser, trimmer, oscillator	Part of C1
C2	Condenser, i-f neutralizing, 1.5 μ f.	30-1221-7
C3	Condenser, screen by-pass, .004 μ f.	30-1239*
C4	Condenser, B- to chassis, .1 μ f.	30-4650-47*
C5	Condenser, d-c blocking, 47 μ f.	60-00475420*
C6	Condenser, grid by-pass .004 μ f.	30-1239*
C7	Condenser, temperature compensating, 7.5 μ f.	30-1224-83
C8	Condenser, filament by-pass, .25 μ f.	30-4656-1
C9	Condenser, neutralizing 3.3 μ f.	30-1221
C10	Condenser, audio circuit	30-1237
C10A	Condenser, audio coupling .001 μ f.	Part of C10
C10B	Condenser, screen by-pass, .01 μ f.	Part of C10
C10C	Condenser, d-c blocking, .002 μ f.	Part of C10
C10D	Condenser, grid by-pass, 220 μ f.	Part of C10
C11	Condenser, tone compensation, .004 μ f.	30-4650-56*
C12	Condenser, electrolytic, filament by-pass, 50 μ f.	30-2417-12
C13	Condenser, electrolytic, filter	30-2568-39
C13A	Condenser, filter, 40 μ f.	Part of C13
C13B	Condenser, filter, 10 μ f.	Part of C13
C13C	Condenser, filter, 50 μ f.	Part of C13
C14	Condenser, line by-pass, .047 μ f.	30-4650-45*
C15	Condenser, a-v-c by-pass, .05 μ f.	30-4650-45*
CR1	Rectifier, selenium	34-8003
J1	Private listening unit	42-1975-2
LA1	Coil, antenna	32-4455-9
LS1	Loudspeaker	36-1637
R1	Resistor, filament dropping, 820 ohms	66-1828340*
R2	Resistor, grid leak, 68,000 ohms	66-3688340*
R3	Resistor, cathode bias, 470 ohms	66-1478340*
R4	Resistor, B- to chassis, 150,000 ohms	66-4158340*
R5	Resistor, screen dropping, 15,000 ohms	66-3158340*
R6	Resistor, grid leak, 3.3 megohms	66-5338340*
R7	Resistor, a-v-c load, 2.2 megohms	66-5228340*
R8	Volume control, 1 megohm	33-5566-21
R9	Resistor, grid leak, 4.7 megohms	66-5478340*
R10	Resistor, screen dropping, 4.7 megohms	66-5478340*
R11	Resistor, plate load, 680,000 ohms	66-4688340*
R12	Resistor, grid leak, 2.2 megohms	66-5228340*
R13	Resistor, filament dropping, 2200 ohms	66-2228340*
R14	Resistor, limiting, 2100 ohms	33-3445
R15	Resistor, B+ filter, 820 ohms	66-1828340*
R16	Resistor, limiting, 120 ohms	33-1334-14
R17	Resistor, filament dropping, 1500 ohms	66-2158340*
R18	Resistor, battery economizer, 150 ohms	66-1158340*
R19	Resistor, battery economizer, 430 ohms	66-1438340*
R20	Resistor, private listening unit, 10 ohms	66-0108340*

Reference Symbol	Description	Service Part No.
S1	Switch, on-off	Part of R8
S2	Switch, battery economizer	42-1796-3
T1	Transformer, oscillator	32-4453-1
T2	Transformer, output	32-8434
W1	Line cord	L2183*
WS1	Switch, wafer, battery to line	42-1925-1
Z1	Transformer, 1st i-f	32-4160-4A
Z2	Transformer, 2nd i-f	32-4454-1A

MISCELLANEOUS

Description	Service Part No.
Cabinet, pine green	10954-10
Back, pine green	54-6010-5
Handle, pine green	54-6012-5
Jack, cover	54-4967-11
Knob (2)	54-6016-2
Cabinet, cherry	10954-12
Back, cherry	54-6010-6
Handle, cherry	54-6012-6
Jack, cover	54-4967-10
Knob (2)	54-6016-1
Cabinet, spruce green	10954-16
Back, spruce green	54-6010-8
Handle, spruce green	54-6012-8
Jack, cover	54-4967-8
Knob (2)	54-6016-3
Cabinet, pearl grey	10954-18
Back, pearl grey	54-6010-9
Handle, pearl grey	54-6012-9
Jack, cover	54-4967-12
Knob (2)	54-6016-9
Cable, battery	41-3988-1
Clip, cabinet back (2)	56-9162
Dial scale	56-9986
Backplate assembly, dial	76-8177
Window, dial	54-6011
Drive cord, 25-ft. spool	45-8750*
Spring, gang drive	56-2617*
Spring, pointer drive	28-8953
Fastener, speaker baffle (2)	W2235-7FA9
Hinge, cabinet (2)	56-5457
Insulator, tuning-condenser mtg.	27-9508
Pointer assembly	76-8071
Ring, handle mtg. (2)	56-9987
Rubber mount, tuning-condenser mtg. (3)	27-4099-3
Shaft, tuning	56-7906FA42
Shield, tube base	56-3978-1FA3
Socket, tube (2)	27-6203
Socket, tube (2)	27-6203-12
Spring, hairpin, shaft mtg.	28-8610
Spring, retaining	57-1868FA11

SPECIFICATIONS

CABINET.....	Molded plastic
CIRCUIT.....	Four-tube superheterodyne plus rectifier
FREQUENCY RANGES.....	
Broadcast.....	540—1620 kc.
Special Services.....	1700—3400 kc.
AUDIO OUTPUT.....	3 watts
OPERATING VOLTAGE.....	105—120 volts, 60 cycles, a.c.
POWER CONSUMPTION.....	
Radio.....	35 watts
Phonograph.....	60 watts
INTERMEDIATE FREQUENCY.....	455 kc.
ANTENNA.....	Built-in high-impedance loop; provision for external antenna
PHILCO TUBES.....	7A8 converter; 7B7 i-f amplifier; 7C6 detector-a.v.c.-1st audio; 35L6GT output; 50Y7GT rectifier
PHONOGRAPH.....	Philco Model M-24 All-Speed Automatic Record Changer

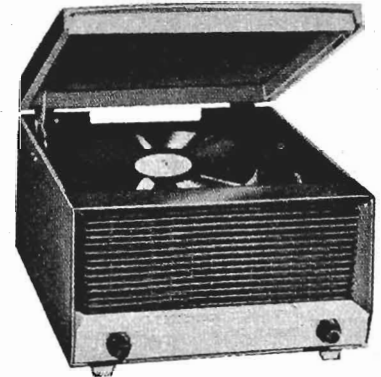

MODEL B1350

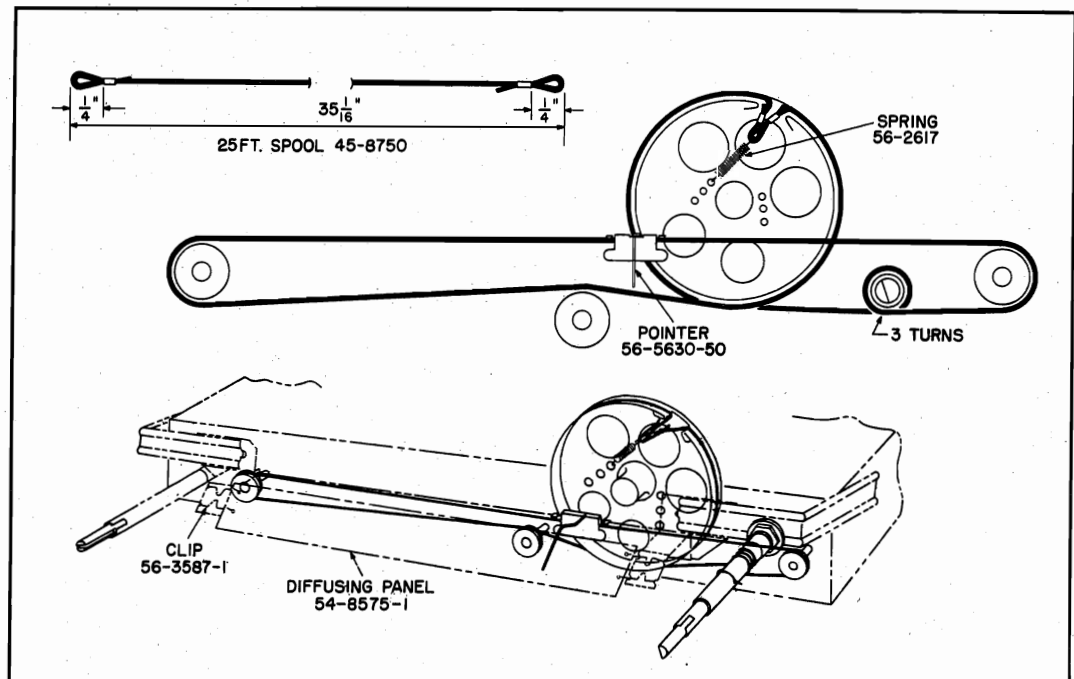

TP2-2587

Figure 1. Drive-Cord Installation Details

PR-2555

MODEL B1350

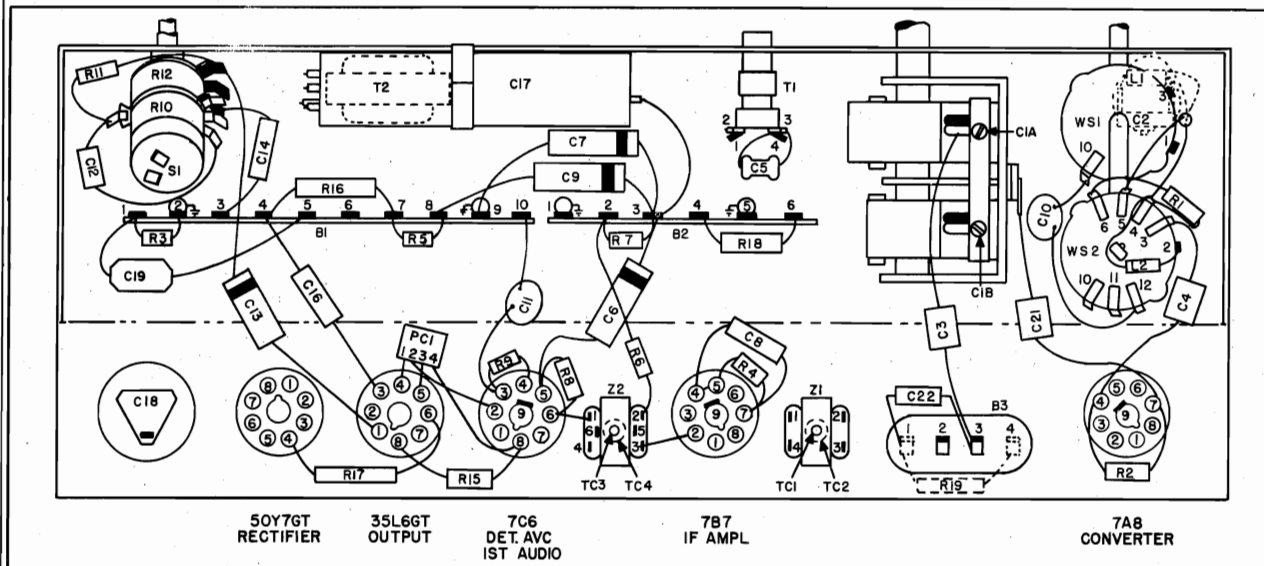

TP2-2588

Figure 2. Base View, Showing Parts Placement and Alignment Points

ALIGNMENT PROCEDURE

GENERAL—In order to perform the alignment procedure it is necessary to remove the front of the cabinet from the back portion of the cabinet holding the record changer. This front part of the cabinet can be removed by loosening the front screws located on the bottom of the cabinet, and the screws located directly under the front of the changer lid.

DIAL POINTER—With the tuning-condenser plates fully meshed, set the dial pointer to coincide with the index mark located to the left of "55" on the dial scale.

CONTROLS—Set the volume control to maximum and the tone control to the treble position. Set the radio-phono switch to the broadcast position for the

first three steps of the procedure, and to the special services position for the last step. Set the tuning control as indicated in the chart.

OUTPUT INDICATOR—Connect the output indicator (a 1000-ohms-per-volt voltmeter or an oscilloscope) across the voice-coil terminals.

SIGNAL GENERATOR—Use an amplitude-modulated r-f generator. Connect the ground lead to B-, and the output lead as indicated in the chart.

OUTPUT LEVEL—During the alignment, attenuate the signal-generator output to maintain the output indication below 1 volt.

ALIGNMENT CHART

STEP	SIGNAL GENERATOR		RADIO		ADJUST TRIMMER
	CONNECTION TO RADIO	DIAL SETTING	DIAL SETTING	SPECIAL INSTRUCTIONS	
1	Output lead through a .01- μ f. condenser to grid (pin 6) of 7A8 converter tube.	455 kc. (modulated)	Gang fully open.	Adjust, in order given in next column, for maximum output. TC2 and TC4 are located at top of transformers.	TC4—2nd i-f sec. TC3—2nd i-f pri. TC2—1st i-f sec. TC1—1st i-f pri.
2	Radiating loop (see note 1 below).	1620 kc.	1620 kc. (see note 2 below).	Adjust for maximum output.	C1B—oscillator trimmer
3	Same as step 2.	1500 kc.	1500 kc.	Adjust for maximum output.	C1A—antenna trimmer (broadcast)
4	Same as step 2.	3200 kc.	3200 kc.	Adjust for maximum output.	C2 — antenna trimmer (special services)

NOTE 1: Make up a 6-8 turn, 6-inch-diameter loop from insulated wire; connect to signal-generator leads, and place near radio loop.

NOTE 2: The tuning gang can be set to 1620 kc. by placing a piece of 6-mil flat shim stock between the heel of the rotor and the top of the stator plates, and moving the rotor until it holds the shim in place. Remove the shim before proceeding with the alignment.

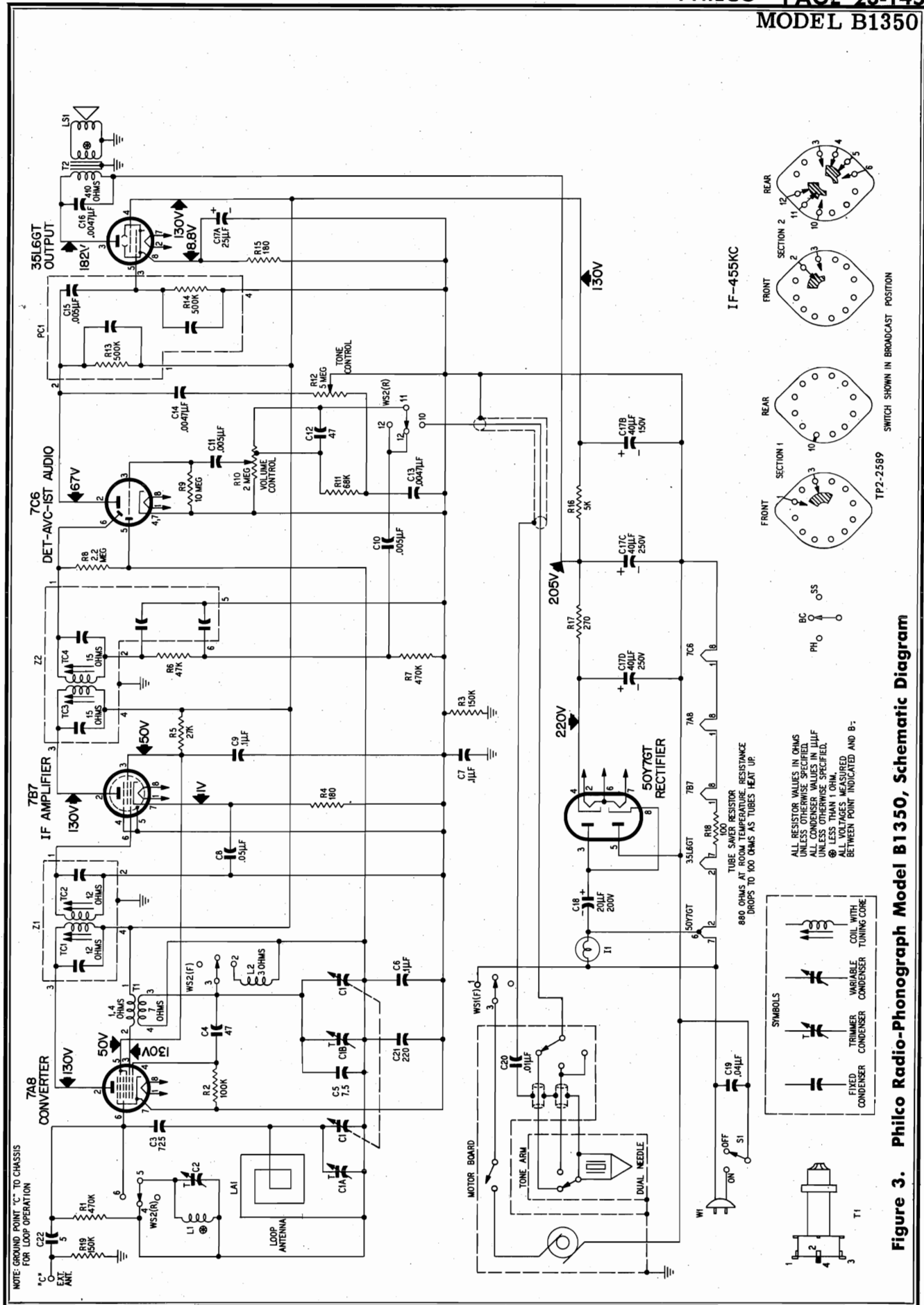

Figure 3. Philco Radio-Phonograph Model B1350, Schematic Diagram

MODEL B1350

PARTS LIST

NOTE: Part numbers identified by an asterisk (*) are general replacement items. These numbers may not be identical with those on factory parts. Also, the electrical values of some replacement items may differ from the values indicated in the schematic diagram and parts list. The values substituted in any case are so chosen that the operation will be unchanged. When ordering replacements, use only the "Service Part No."

Reference Symbol	Description	Service Part No.	Reference Symbol	Description	Service Part No.
C1	Condenser, tuning gang	31-2751-9	R15	Resistor, cathode bias, 180 ohms, 1 watt	66-1184340*
C1A	Condenser, trimmer, antenna	Part of C1	R16	Resistor, filter, 5000 ohms, 7 watts	33-1335-95
C1B	Condenser, trimmer, oscillator	Part of C1	R17	Resistor, filter, 270 ohms, 7 watts	33-1335-91
C2	Condenser, trimmer, special services antenna	31-6473-31	R18	Resistor, tube saver, 100 ohms	33-1343-3
C3	Condenser, series tracker, 725 μ f.	30-1220-69	R19	Resistor, aerial loading, 150,000 ohms	66-4158340*
C4	Condenser, d-c blocking, 47 μ f.	60-00475420	S1	Switch, off-on	Part of R10
C5	Condenser, fixed trimmer, 7.5 μ f.	30-1224-65	T1	Transformer, oscillator	32-4453-2
C6	Condenser, a-v-c by-pass, .1 μ f.	30-4650-47*	T2	Transformer, output	32-8242-9
C7	Condenser, by-pass, .1 μ f.	30-4650-47*	W1	Line cord	L-2183*
C8	Condenser, cathode by-pass, .05 μ f.	30-4650-45*	WS	Wafer switch, 2-section	42-1989
C9	Condenser, screen by-pass, .1 μ f.	30-4650-47*	Z1	Transformer, 1st i-f	32-4160A
C10	Condenser, d-c blocking, .005 μ f.	30-1238-1*	Z2	Transformer, 2nd i-f	32-4240A
C11	Condenser, d-c blocking, .005 μ f.	30-1238-1*			
C12	Condenser, high-frequency compensation, 47 μ f.	60-00475420			
C13	Condenser, bass compensation, .0047 μ f.	30-4650-56*			
C14	Condenser, tone, .0047 μ f.	30-4650-56*			
C15	Condenser, d-c blocking, .005 μ f.	Part of PC1			
C16	Condenser, tone compensation, .0047 μ f.	30-4650-56			
C17	Condenser, electrolytic, 4-section	30-2575-32			
C17A	Condenser, cathode by-pass, 25 μ f., 50v.	Part of C17			
C17B	Condenser, filter, 40 μ f., 150v.	Part of C17			
C17C	Condenser, filter, 40 μ f., 250v.	Part of C17			
C17D	Condenser, filter, 40 μ f., 250v.	Part of C17			
C18	Condenser, voltage doubling, 20 μ f., 200v.	30-2568-22			
C19	Condenser, line by-pass, .04 μ f.	30-1226-17*			
C20	Condenser, phono isolation, .01 μ f.	30-4650-58*			
C21	Condenser, a-v-c decoupling, 220 μ f.	62-122001001*			
C22	Condenser, aerial blocking, 5 μ f.	30-1221-5			
II	Lamp, pilot	34-2064*			
L1	Coil, antenna, special services	32-4561-5			
L2	Coil, oscillator shunt	32-4562-1			
LA1	Loop assembly, antenna	76-2127-16			
LS1	Speaker	36-1639-1			
PC1	Printed circuit, d-c blocking	30-6001			
R1	Resistor, grid return, 470,000 ohms	66-4478340*			
R2	Resistor, grid leak, 100,000 ohms	66-4108340*			
R3	Resistor, B- to chassis, 150,000 ohms	66-4158340*			
R4	Resistor, cathode bias, 180 ohms	66-1188340*			
R5	Resistor, screen dropping, 27,000 ohms	66-3278340*			
R6	Resistor, i-f filter, 47,000 ohms	66-3478340*			
R7	Resistor, diode return, 470,000 ohms	66-4478340*			
R8	Resistor, diode load, 2.2 megohms	66-5228340*			
R9	Resistor, grid leak, 10 megohms	66-6108340*			
R10	Volume control, 2 megohms (with off-on switch and tone control)	33-5563-55			
R11	Resistor, bass compensation, 68,000 ohms	66-3688340*			
R12	Tone control, 5 megohms	Part of R10			
R13	Resistor, plate load, 500,000 ohms	Part of PC1			
R14	Resistor, grid leak, 500,000 ohms	Part of PC1			

MISCELLANEOUS

Description	Service Part No.
Cabinet	10949
Bottom cover	54-8255-1
Hinge (2)	56-6603
Lid	54-4990
Lid support	56-6604
Binder post	56-6296
Changer Mounting Hardware	
Sleeve, rubber (3)	54-7798
Speed nut (3)	W-2554
Spring, mounting, top (3)	56-7059FA9
Spring, mounting, bottom (3)	56-7059-1FCP
Dial scale	54-5156
Drive cord, 25 ft. spool	45-8750*
Foot, rubber (4)	54-4579
Gasket, speaker	54-8089
Knob, off-on-volume	54-4842-8
Knob, radio-phono-Special Services	54-4842-9
Knob, tuning	54-4841
Knob, tone	54-4841-10
Lead assembly, antenna	76-1472
Mounting foot (4)	56-7778-1
Mount, rubber (3)	27-4596
Panel, diffusing	54-8575-1
Clip, diffusing panel (2)	56-3587-1
Pilot-lamp socket assembly	76-1179-7
Fastener, pilot-lamp shield (2)	W2235-1FA9
Pointer	56-5630-50
Rail assembly, pointer	76-7906
Spring, pointer drive	56-2617*
Socket, Loktal (3)	27-6207*
Socket, octal (2)	27-6174*
Spring, hairpin	56-6552
Tuning shaft	56-8370-1

SPECIFICATIONS

CABINET.....	Plastic table model
CIRCUIT.....	Six-tube superheterodyne plus selenium rectifier
FREQUENCY RANGES	
Broadcast.....	540—1620 kc.
FM.....	88—108 mc.
AUDIO OUTPUT.....	1 watt
OPERATING VOLTAGE.....	105—125 volts, a.c./d.c.
POWER CONSUMPTION.....	45 watts
AERIAL.....	Built-in pancake loop for AM, line cord for FM; provision for connecting external aerial
INTERMEDIATE FREQUENCY	
AM.....	455 kc.
FM.....	9.1 mc.
PHILCO TUBES (6).....	12AU6 r-f ampl., 12AT7 converter, 12BA6 1st i-f ampl., 12AU6 2nd i-f ampl., 19V8 det.-a.v.c.-1st audio, 35C5GT output

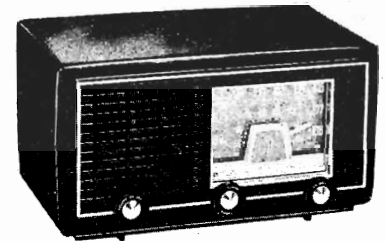

MODEL B956

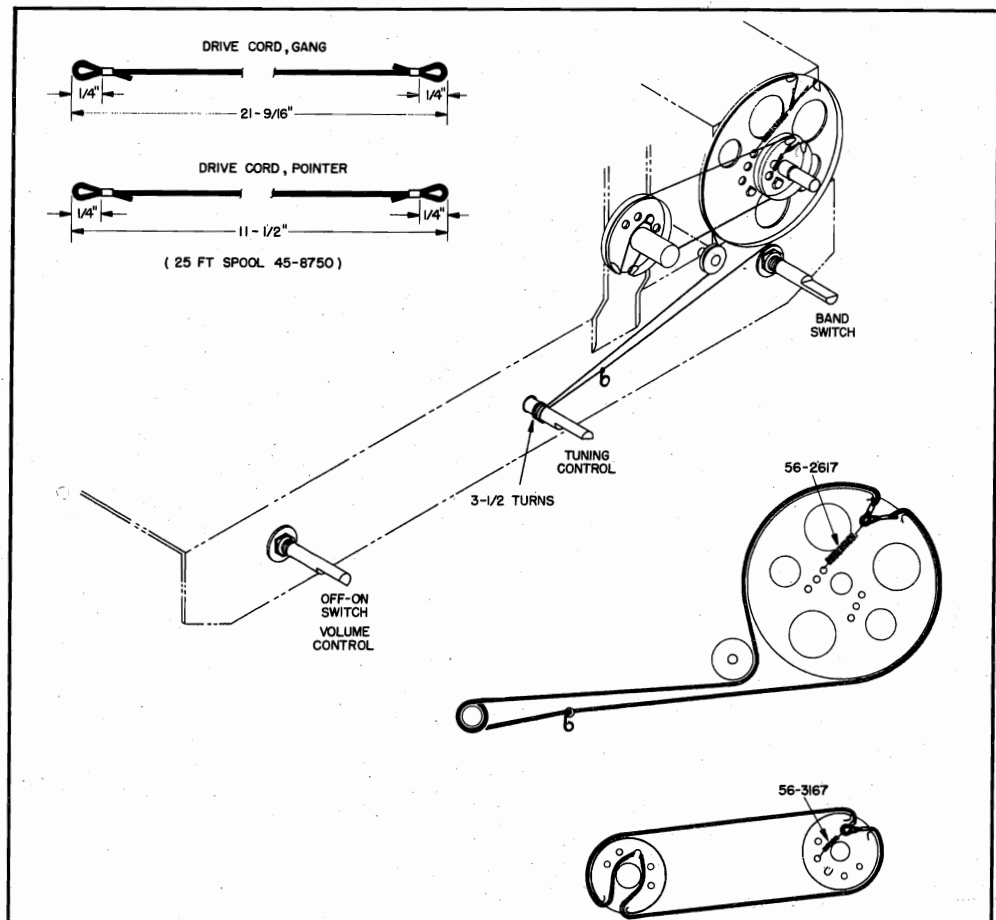

Figure 1. Drive-Cord Installation Details

TP2-2260

PR-2551

MODEL B956

AM ALIGNMENT PROCEDURE

Make alignment with loop aerial connected to radio. The AM alignment should be completed before the FM alignment is made.

DIAL POINTER—With tuning-condenser plates fully meshed, adjust pointer to coincide with index mark at low-frequency end of dial backplate.

RADIO CONTROLS—Set volume control to maximum, set band switch for broadcast reception, and set tuning control as indicated in chart.

OUTPUT METER—Connect across voice-coil terminals.

SIGNAL GENERATOR—Use AM r-f signal generator, with modulated output. Connect generator and set frequency as indicated in chart.

OUTPUT LEVEL—During alignment, signal-generator output must be attenuated to hold output-meter reading below 1.25 volts.

AM ALIGNMENT CHART

STEP	SIGNAL GENERATOR		RADIO		ADJUST
	CONNECTION TO RADIO	DIAL SETTING	DIAL SETTING	SPECIAL INSTRUCTIONS	
1	Ground lead to chassis. Output lead through a .1- μ f. condenser to junction of LA1 and L8.	455 kc.	Gang fully open.	Adjust for maximum output, in order given.	TC10—2nd AM i-f sec. TC9—2nd AM i-f pri. TC4—1st AM i-f sec. TC3—1st AM i-f pri.
2	Radiating loop (see note below).	1620 kc.	1620 kc. (2nd index mark from right).	Adjust for maximum output.	C1C—osc. trimmer.
3	Same as step 2.	1500 kc.	1500 kc.	Adjust for maximum output.	C1A—aerial trimmer.

RADIATING LOOP: Make up a six-to-eight turn, 6-inch-diameter loop from insulated wire; connect to generator terminals, and place near radio loop aerial. Radio loop aerial must be connected.

FM ALIGNMENT PROCEDURE

Make AM alignment first

RADIO CONTROLS—Set volume control to maximum, set band switch for FM reception, and set tuning control as indicated in chart.

OSCILLOSCOPE—Connect ground lead to chassis. Connect vertical input to FM TEST jack, J2; connect horizontal input to horizontal sweep output of sweep generator. (Oscilloscope is used for steps 1 and 2.)

SWEEP GENERATOR—Use FM r-f sweep signal generator. Connect output lead as given in chart. Set frequency and sweep width as indicated in chart.

OUTPUT METER—Connect across voice-coil terminals.

NOTE: Before starting FM alignment, allow radio and signal generator to warm up for 15 minutes.

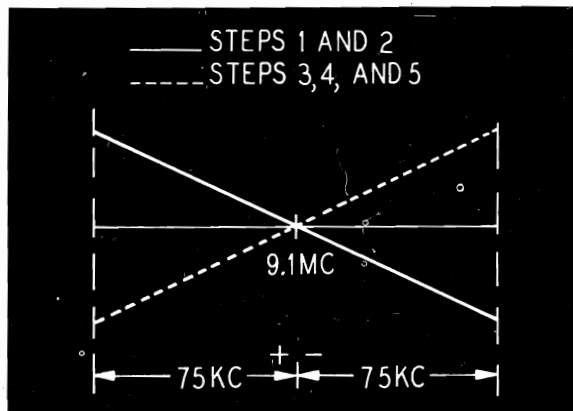

TP1-2111

Figure 2. Characteristic Curve of FM Detector

FM ALIGNMENT CHART

STEP	SIGNAL GENERATOR		RADIO		ADJUST
	CONNECTION TO RADIO	DIAL SETTING	DIAL SETTING	SPECIAL INSTRUCTIONS	
1	Ground lead to chassis. Output lead through a .01- μ f. condenser to control grid (pin 1) of 12AU6 2nd i-f amplifier.	9.1 mc. (75-kc. deviation).	88 mc. (gang meshed).	Balance and adjust detector for maximum indication on scope, as shown in figure 2.	TC8—detector sec. TC7—detector pri.

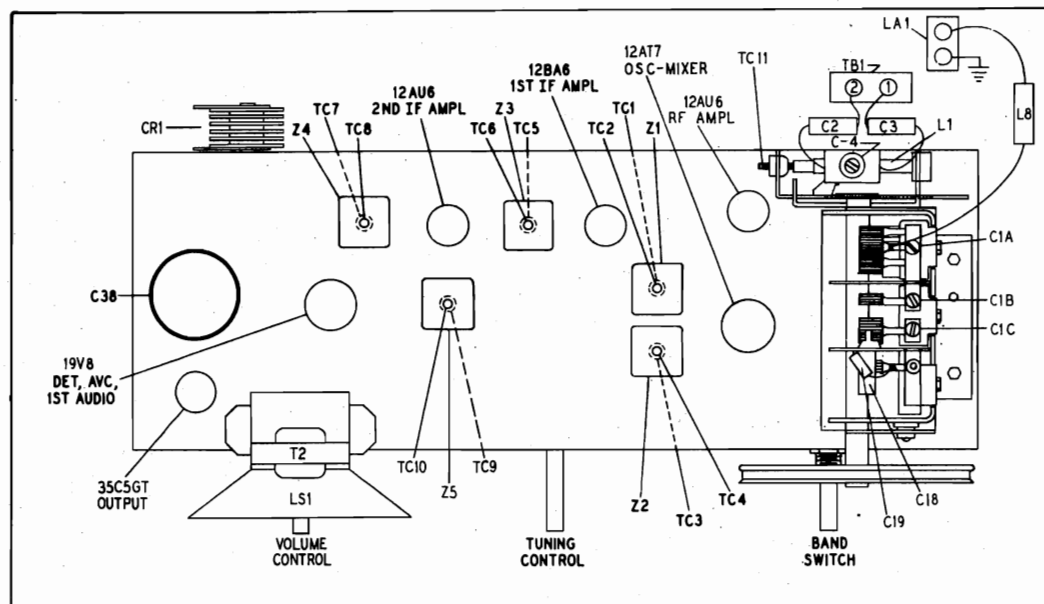

TP2-2261

Figure 3. Top View, Showing Trimmer Locations

FM ALIGNMENT CHART (Continued)

STEP	SIGNAL GENERATOR		RADIO		ADJUST
	CONNECTION TO RADIO	DIAL SETTING	DIAL SETTING	SPECIAL INSTRUCTIONS	
2	Ground lead to chassis. Output lead through a .01- μ f. condenser to FM tuning gang stator lug, junction of C1 and pin 4 of L2.	Same as step 1.	Same as step 1.	Adjust for maximum indication on scope, as shown in figure 2.	TC6—FM 2nd i-f sec. TC5—FM 2nd i-f pri. TC2—FM 1st i-f sec. TC1—FM 1st i-f pri.
3	Ground lead to lug 3 of TB1. Output lead to lug 2 of TB1. See note 1 below.	108.5 mc.	108.5 mc. (1st index mark from right).	Adjust for maximum indication on output meter.	C18—FM osc.
4	Same as step 3.	88 mc.	88 mc. (1st index mark from left).	Adjust for maximum indication on output meter. See note 2 below.	L5—FM osc.
5	Same as step 3.	105 mc.	105 mc. (3rd index mark from right).	Adjust for maximum indication on output meter while rocking tuning condenser.	C1B—FM r-f.
6	Same as step 3.	105 mc.	105 mc.	Adjust for maximum indication on output meter.	C4—FM aerial.
7	Same as step 3.	92 mc.	92 mc. (3rd index mark from left).	Adjust for maximum indication on output meter. See note 3 below.	L2—FM r-f coil.
If FM aerial coil, L1, is replaced, it should be adjusted as directed in step 8, below.					
8	Same as step 3.	92 mc.	92 mc.	Adjust for maximum indication on output meter.	TC11—FM aerial

NOTE 1: For accurate results, the signal-generator output impedance must be 300 ohms, to match the input impedance of TB1. If the generator impedance is less than 300 ohms, a resistor of the proper value may be used in series with the output lead to make the impedance correct. For example, if the output impedance is 150 ohms, place a 150-ohm resistor in series with the output lead.

NOTE 2: If oscillator does not tune as low as 88 mc., compress the turns on the oscillator coil. If oscillator tunes too low, spread the turns slightly. After coil is adjusted, repeat step 3.

NOTE 3: Check resonance of coil L2 by inserting end of a tuning wand, such as Philco Part No. 56-6100, in the coil. If output increases when iron end is placed in coil, compress turns slightly. If output increases when brass end is placed in coil, spread the turns. If output decreases when either end is placed in coil, no adjustment is necessary. After the coil is adjusted, readjust trimmer C1B and repeat steps 3 through 8 until no further improvement is obtained.

MODEL B956

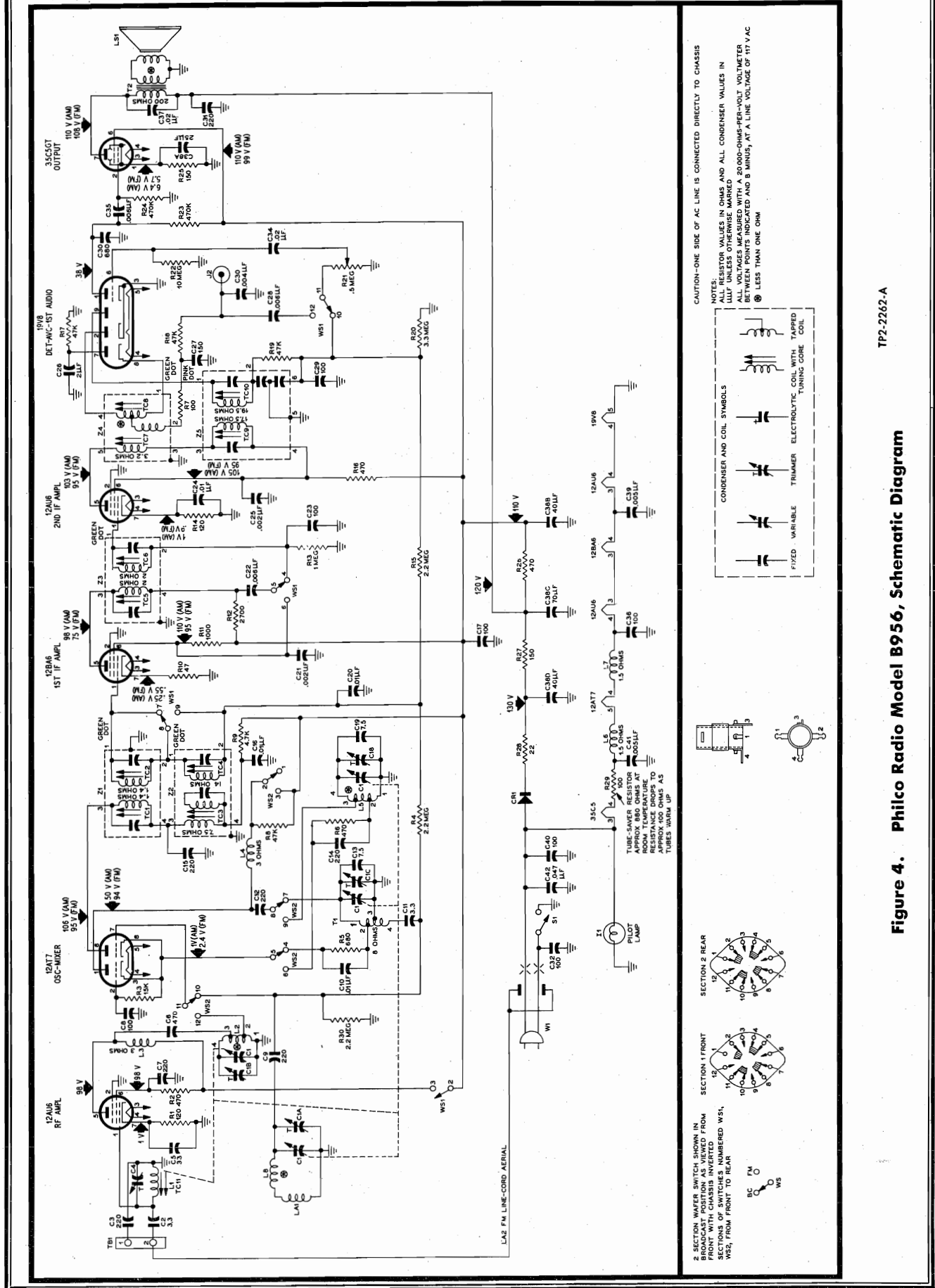

CAUTION—ONE SIDE OF AC LINE IS CONNECTED DIRECTLY TO CHASSIS

NOTES:

ALL RESISTOR VALUES IN OHMS AND ALL CONDENSER VALUES IN MICROFARADS UNLESS OTHERWISE INDICATED.

ALL VOLTAGES MEASURED WITH A 2000-OHMS-PER-VOLT VOLTMETER BETWEEN POINTS INDICATED AND B MINUS, AT A LINE VOLTAGE OF 117 V AC

⊕ LESS THAN ONE OHM

TP2-2262-A

Figure 4. Philco Radio Model B956, Schematic Diagram

PARTS LIST

NOTE: Part numbers identified by an asterisk (*) are general replacement items. These numbers may not be identical with those on factory parts. Also, the electrical values of some replacement items may differ from the values indicated in the schematic diagram and parts list. The values substituted in any case are so chosen that the operation will be unchanged. When ordering replacements, use only the "Service Part No."

Reference Symbol	Description	Service Part No.	Reference Symbol	Description	Service Part No.
C1	Condenser, tuning gang, 5-section	31-2762-1	C38D	Condenser, filter, 40 μ f., 150v	Part of C38
C1A	Condenser, trimmer, BC aerial	Part of C1	C39	Condenser, filament by-pass, .005 μ f.	30-1238-1*
C1B	Condenser, trimmer, FM r-f	Part of C1	C40	Condenser, line by-pass, 100 μ f.	62-110001021*
C1C	Condenser, trimmer, BC oscillator	Part of C1	C41	Condenser, filament by-pass, .005 μ f.	30-1238-1*
C2	Condenser, aerial isolating, 3.3 μ f.	30-1221	C42	Condenser, line by-pass, .047 μ f.	30-4650-45*
C3	Condenser, aerial isolating, 220 μ f.	62-122001001*	CR1	Selenium rectifier, 100 ma., 117v	34-8003-1
C4	Condenser, FM aerial trimmer	45-3034	I1	Pilot lamp, frosted, 117v, 7 watts	34-2605
C5	Condenser, cathode by-pass, 33 μ f.	62-033009001	J1	Jack, male, a-c	27-6240-5
C6	Condenser, d-c blocking, 470 μ f.	62-147001021*	J2	Socket, FM test	27-6180
C7	Condenser, screen by-pass, 220 μ f.	62-122001001*	L1	Coil, FM aerial, complete with grommet	32-4532A
C8	Condenser, oscillator grid, 100 μ f.	62-110001021*	L2	Coil, FM r-f	32-4415-2
C9	Condenser, d-c blocking, 220 μ f.	62-122001001*	L3	Choke, r-f, 3.3 μ h.	32-4422-10
C10	Condenser, cathode by-pass, .01 μ f.	30-4650-58*	L4	Choke, r-f, 3.3 μ h.	32-4422-10
C11	Condenser, neutralizing, 3.3 μ f.	30-1224-49	L5	Coil, FM oscillator	32-4414-5
C12	Condenser, d-c blocking 220 μ f.	62-122001001*	L6	Choke, filament, 2.2 μ h.	32-4422-8
C13	Condenser, fixed trimmer, 7.5 μ f.	30-1224-65	L7	Choke, filament, 2.2 μ h.	32-4422-8
C14	Condenser, cathode by-pass, 220 μ f.	62-122001001*	L8	Choke, r-f, 4.1 μ h.	32-4061-3
C15	Condenser, r-f by-pass, 220 μ f.	62-122001001*	LA1	AM loop and support assembly	76-7836
C16	Condenser, plate decoupling, .01 μ f.	30-4650-58*	LA2	Line-cord aerial, FM	Part of W1
C17	Condenser, r-f by-pass, 100 μ f.	62-110009001*	LS1	Speaker, 4" p-m, including output transformer	36-1625-14
C18	Condenser, trimmer, FM oscillator	31-6511-10	R1	Resistor, cathode bias, 120 ohms	66-1128340*
C19	Condenser, fixed trimmer, 7.5 μ f.	30-1224-8	R2	Resistor, screen decoupling, 470 ohms	66-1478340*
C20	Condenser, a-v-c decoupling, .01 μ f.	30-4650-58*	R3	Resistor, grid return, 15,000 ohms	66-3158340*
C21	Condenser, screen by-pass, .002 μ f.	30-4650-54*	R4	Resistor, grid return, 2.2 megohms	66-5228340*
C22	Condenser, neutralizing, .006 μ f.	30-4650-57*	R5	Resistor, parasitic suppressor, 680 ohms	66-1688340*
C23	Condenser, i-f by-pass, 100 μ f.	62-110001021*	R6	Resistor, parasitic suppressor, 470 ohms	66-1478340*
C24	Condenser, cathode by-pass, .01 μ f.	30-4650-58*	R7	Resistor, loading, 100 ohms	66-1108340*
C25	Condenser, screen by-pass, .002 μ f.	30-4650-54*	R8	Resistor, plate dropping, AM, 47,000 ohms	66-3478340*
C26	Condenser, electrolytic, diode-load filter, 2 μ f., 50v	30-2417-7	R9	Resistor, plate dropping, 4700 ohms	66-2478340*
C27	Condenser, i-f by-pass, 150 μ f.	62-115001011*	R10	Resistor, cathode bias, 47 ohms	66-0478340*
C28	Condenser, d-c blocking, .006 μ f.	30-4650-57*	R11	Resistor, screen decoupling, 1000 ohms	66-2108340*
C29	Condenser, i-f by-pass, 100 μ f.	62-110001021*	R12	Resistor, plate decoupling, 2700 ohms	66-2278340*
C30	Condenser, de-emphasis, .004 μ f.	30-4650-56*	R13	Resistor, grid return, 1 megohm	66-5108340*
C31	Condenser, plate decoupling, 220 μ f.	62-122001001*	R14	Resistor, cathode bias, 120 ohms	66-1128340*
C32	Condenser, line by-pass, 100 μ f.	62-110001021*	R15	Resistor, a-v-c filter, 2.2 megohms	66-5228340*
C33	Condenser, plate by-pass, 680 μ f.	62-168001001*	R16	Resistor, decoupling, 470 ohms	66-1478340*
C34	Condenser, d-c blocking, .02 μ f.	30-4650-60*	R17	Resistor, FM diode load, 47,000 ohms	66-3478340*
C35	Condenser, d-c blocking, .006 μ f.	30-4650-57*	R18	Resistor, de-emphasis, 47,000 ohms	66-3478340*
C36	Condenser, filament by-pass, 100 μ f.	62-110001021*	R19	Resistor, i-f filter, 47,000 ohms	66-3478340*
C37	Condenser, tone compensation, .02 μ f.	30-4650-60*	R20	Resistor, a-v-c load, 3.3 megohms	66-5338340*
C38	Condenser, electrolytic, 4-section	30-4650-46	R21	Volume control (with off-on switch) 500,000 ohms	33-5566-20
C38A	Condenser, cathode by-pass, 25 μ f., 25v	Part of C38	R22	Resistor, grid return, 10 megohms	66-6108340*
C38B	Condenser, filter, 40 μ f., 150v	Part of C38	R23	Resistor, plate load, 470,000 ohms	66-4478340*
C38C	Condenser, filter, 70 μ f., 150v	Part of C38	R24	Resistor, grid return, 470,000 ohms	66-4478340*

MODEL B956

PARTS LIST (Cont.)

Reference Symbol	Description	Service Part No.
R25	Resistor, cathode bias, 150 ohms	66-1158340°
R26	Resistor, filter, 470 ohms, 1 watt	66-1474340°
R27	Resistor, filter, 150 ohms, 2 watts	66-1155360°
R28	Resistor, current limiting, 22 ohms, 2 watts	66-0225360°
R29	Resistor, current limiting, 100 ohms	33-1343-3
R30	Resistor, grid return, 2.2 megohms	66-5228340°
S1	Switch, off-on	Part of R21
T1	Transformer, AM oscillator	32-4569-1
T2	Transformer, output	Part of LS1
W1	Line cord	41-3865-3
W2	Cable, FM aerial, 72-ohm twin lead	41-3987
WS	Switch, band, 2-wafer	42-1924-1
Z1	Transformer, FM, 1st i-f	32-4518A
Z2	Transformer, AM, 1st i-f	32-4516A
Z3	Transformer, FM, 2nd i-f	32-4518-1A
Z4	Transformer, FM, detector	32-4310-4A
Z5	Transformer, AM, 2nd i-f	32-4517A

MISCELLANEOUS

Description	Service Part No.
Cabinet	10941
Back, flange, and socket assembly	76-7829

MISCELLANEOUS (Cont.)

Description	Service Part No.
Fastener, back mtg. (4)	W-2235-FA9
Dial scale	54-4987
Knob, FM-AM	54-4774-28
Knob, tuning	54-4774-26
Knob, volume-off-on	54-4774-27
Clip, pilot lamp	56-3545-FA3
Drive cord, 25-foot spool	45-8750°
Pointer	56-9906
Shaft, drive	56-7931FA11
Spring, gang drive	56-2617
Spring, pointer drive	56-3167
Rubber mount, speaker (2)	54-4651-1
Socket, 12BA6 (i-f ampl.)	27-6265
Socket, 12AU6 (i-f ampl.)	27-6265
Socket, 12AU6 (r-f ampl.)	27-6275-1
Socket, 12AT7	27-6203-6
Socket, 19V8	27-6203-6
Socket, 35C5	27-6203-12
Shield, tube (2)	56-5629-3
Shield, tube base (1)	56-3978-1FA3
Shield, tube base (2)	56-5628-1FA3
Socket, assembly, pilot lamp	27-6233-21
Spring, hairpin	28-8610

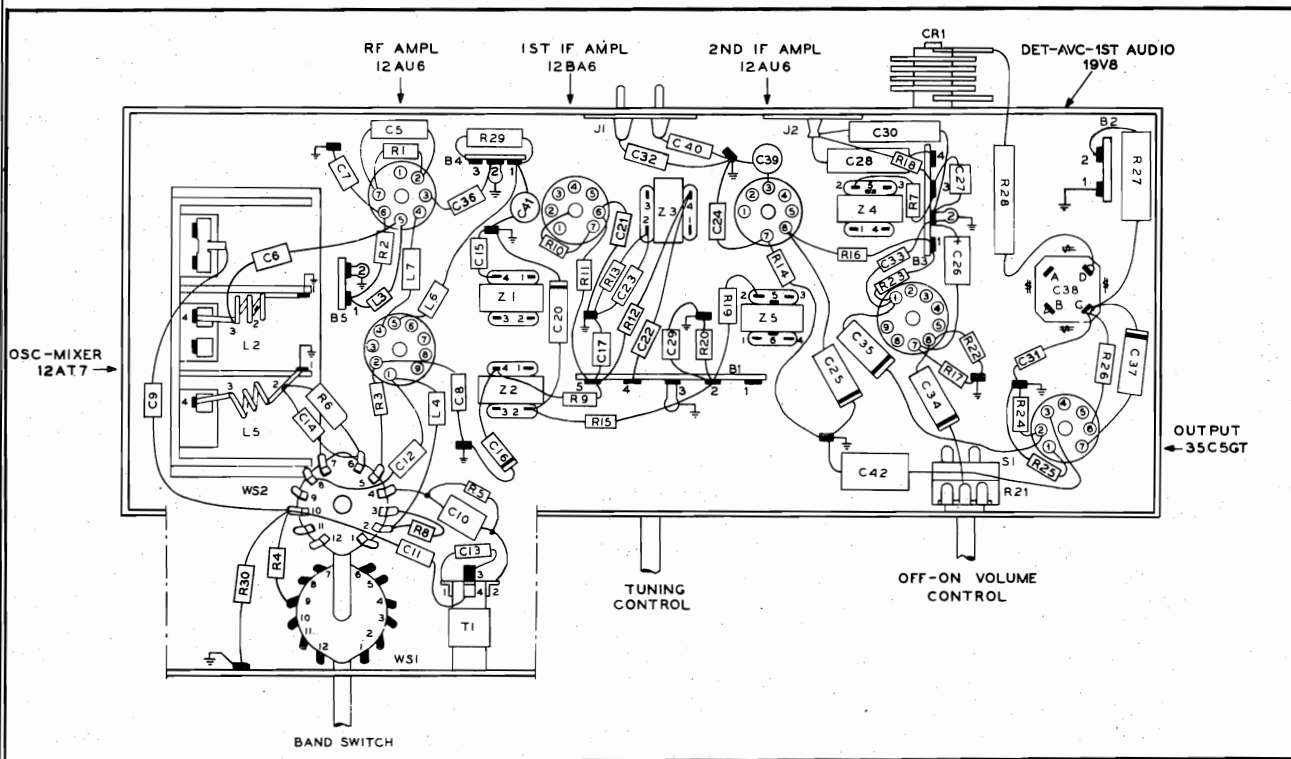

TP2-2263

Figure 5. Base View, Showing Parts Placement

ALIGNMENT PROCEDURE

RADIO CONTROLS—Set volume control to maximum. Set tuning control and band switch as indicated in chart.

OUTPUT METER—Connect across voice-coil terminals.

SIGNAL GENERATOR—Connect generator and set frequency as indicated in chart. Use modulated output.

OUTPUT LEVEL—During alignment, adjust signal-generator output to hold output-meter reading below 1.25 volts.

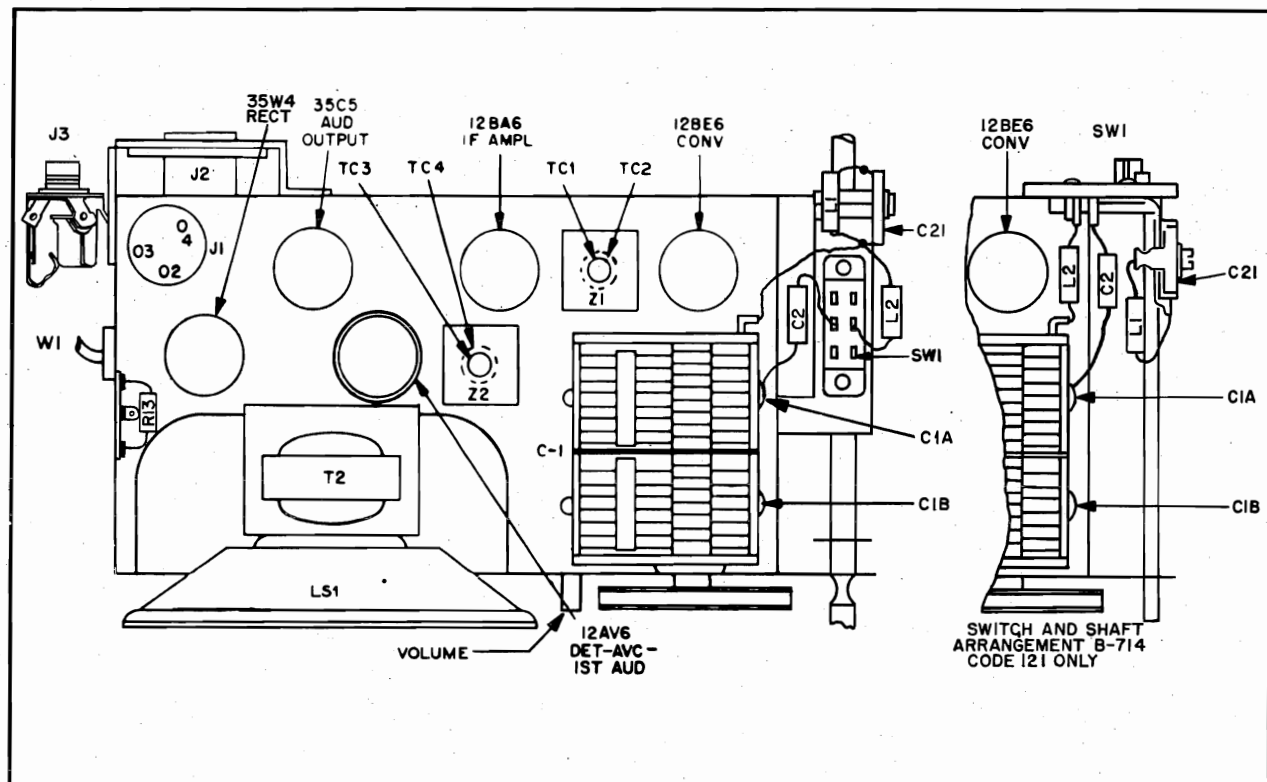

Figure 2. Top View, Showing Trimmer Locations

TP3-940

ALIGNMENT CHART

STEP	SIGNAL GENERATOR		RADIO			ADJUST
	CONNECTION TO RADIO	DIAL SETTING	DIAL SETTING	BAND SWITCH SETTING	SPECIAL INSTRUCTIONS	
1	Ground lead to B-; output lead through a .1- μ f. condenser to grid (pin 7) of 12BE6.	455 kc.	Tuning gang fully open	Broadcast	Adjust tuning cores, in order given, for maximum output. (TC1 and TC3 are located at top of transformers.)	TC4—2nd i-f sec. TC3—2nd i-f pri. TC2—1st i-f sec. TC1—1st i-f pri.
2	Radiating loop (See note below).	1620 kc.	*1620 kc.	Broadcast	Adjust trimmer for maximum output.	C1-B—osc.
3	Same as step 2.	1500 kc.	1500 kc.	Broadcast	Adjust trimmer for maximum output.	C1-A—aerial (broadcast)
4	Same as step 2.	3200 kc.	3200 kc.	Special Services	Adjust trimmer for maximum output.	C21—aerial (special services)

NOTE: Make up a 6-8 turn, 6-inch-diameter loop from insulated wire; connect to signal-generator leads, and place near radio loop.

* For proper adjustment of the oscillator trimmer, fully open the tuning gang and insert a .006-inch, non-metallic shim between the heel of the rotor and the top of the stator plates. Close the tuning gang sufficiently to hold the shim in place, and then remove the shim without disturbing the gang setting.

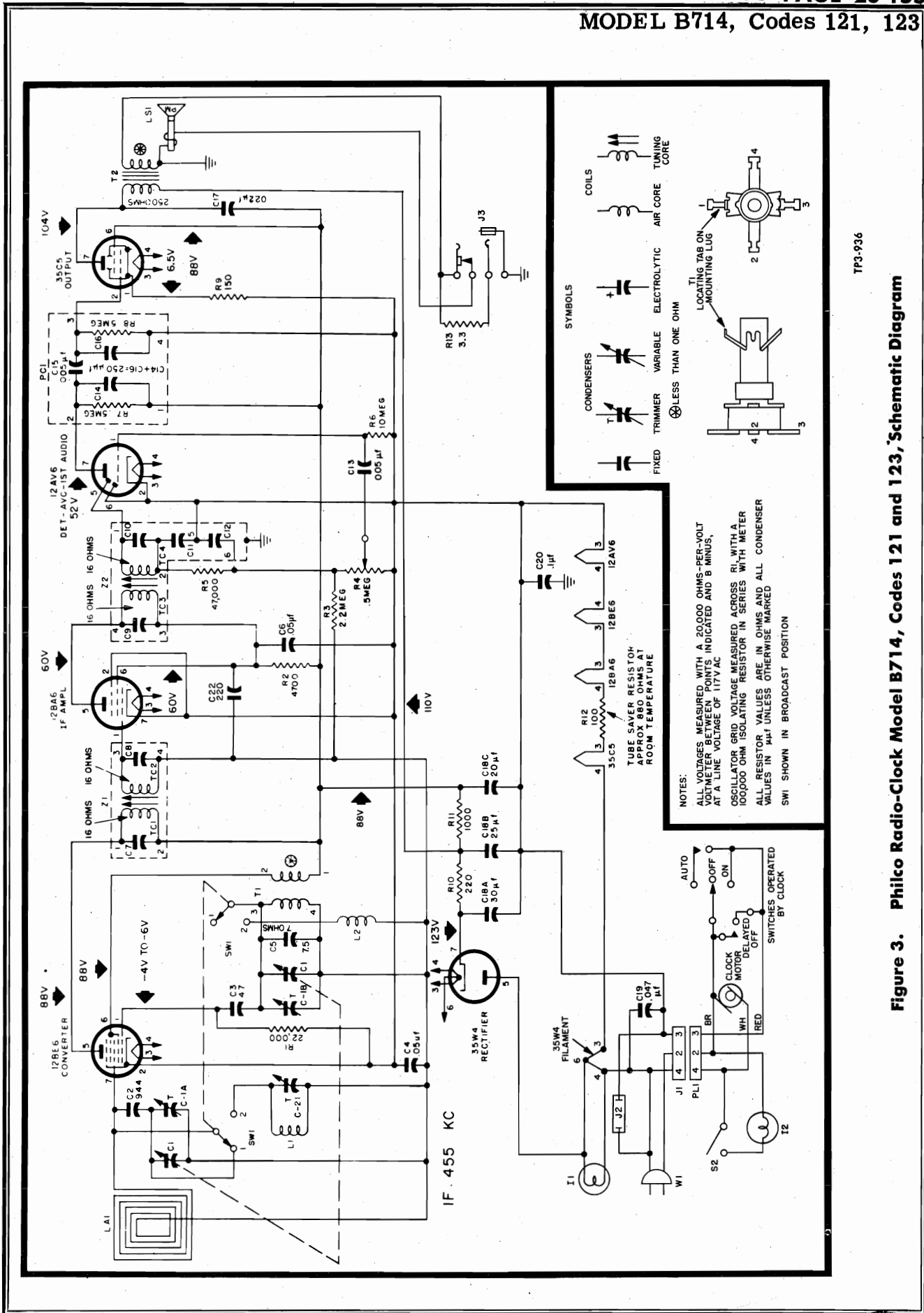

TF3-936

Figure 3. Philco Radio-Clock Model B714, Codes 121 and 123, Schematic Diagram

MODEL B714, Codes 121, 123

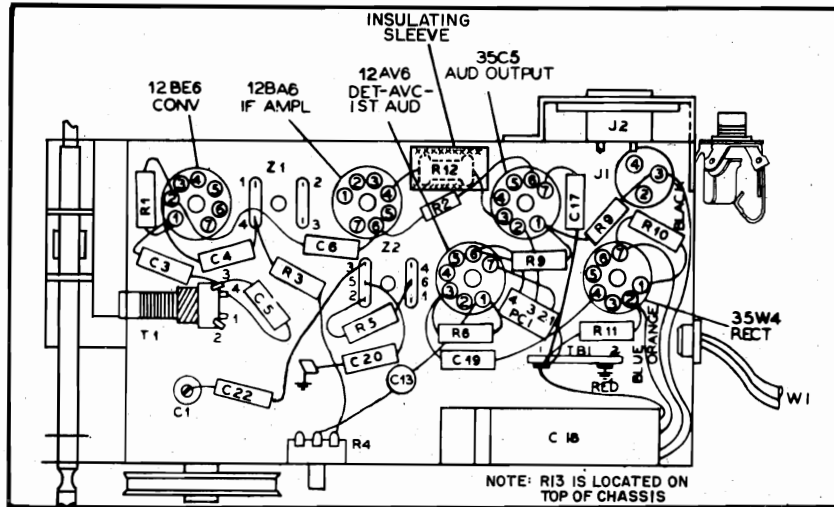

Figure 4. Base View, Showing Parts Placement

PARTS LIST

NOTE: Part numbers identified by an asterisk (*) are general replacement items. These numbers may not be identical with those on factory parts. Also, the electrical values of some replacement items may differ from the values indicated in the schematic diagram and parts list. The values substituted in any case are so chosen that the operation will be unchanged. When ordering replacements, use only the "Service Part No."

Reference Symbol	Description	Service Part No.	Reference Symbol	Description	Service Part No.
C1	Condenser, tuning gang	31-2751-14	R6	Resistor, grid return, 10 megohms	66-6108340*
C1A	Condenser, r-f trimmer	Part of C1	R7	Resistor, plate load, 500,000 ohms	Part of PC1
C1B	Condenser, oscillator trimmer	Part of C1	R8	Resistor, grid return, 500,000 ohms	Part of PC1
C2	Condenser, aerial series tracker, 944 μ f.	30-1220-65	R9	Resistor, cathode bias, 150 ohms	66-1158340*
C3	Condenser, oscillator grid, 47 μ f.	30-1230-4	R10	Resistor, B plus filter, 220 ohms, 1 watt	66-1224340*
C4	Condenser, a-v-c by-pass, .05 μ f.	30-4650-45*	R11	Resistor, B plus filter, 1000 ohms	66-2108340*
C5	Condenser, drift compensation, 7.5 μ f.	30-1224-83	R12	Resistor, tube saver, 100 ohms	33-1343-3
C6	Condenser, screen by-pass, .05 μ f.	30-4650-45*	R13	Resistor, private listening unit, 3.3 ohms	66-9333540
C7	Condenser, i-f tuning	Part of Z1	S2	Switch, night light	42-2023
C8	Condenser, i-f tuning	Part of Z1	SW1	Switch, broadcast-special services	42-1796-2
C9	Condenser, i-f tuning	Part of Z2	T1	Transformer, oscillator	32-4453-6
C10	Condenser, i-f tuning	Part of Z2	T2	Transformer, output	32-8384*
C11	Condenser, detector filtering	Part of Z2	W1	Line cord	L-2183*
C12	Condenser, detector filtering	Part of Z2	Z1	Transformer, 1st i-f	32-4161A
C13	Condenser, audio coupling, .005 μ f.	30-1238-1*	Z2	Transformer, 2nd i-f	32-4240A
C14	Condenser, plate by-pass	Part of PC1			
C15	Condenser, audio coupling, .005 μ f.	Part of PC1			
C16	Condenser, compensating	Part of PC1			
C17	Condenser, tone compensation, .022 μ f.	30-4650-43*			
C18	Condenser, electrolytic, 3-section	30-2573			
C18A	Condenser, filter, 30 μ f., 150v	Part of C18			
C18B	Condenser, filter, 25 μ f., 150v	Part of C18			
C18C	Condenser, filter, 20 μ f., 150v	Part of C18			
C19	Condenser, line by-pass, .047 μ f.	30-4650-45*			
C20	Condenser, B minus to chassis, .1 μ f.	30-4650-47*			
C21	Condenser, trimmer, special services	31-6473-29			
C22	Condenser, a-v-c decoupling, 220 μ f.	62-122001001*			
I1	Lamp, pilot	34-2068			
I2	Lamp, night light	34-2477			
J1	Jack, clock	27-6273			
J2	Jack, appliance receptacle, a-c	76-3931			
J3	Private listening unit	42-1975-2			
L1	Coil, aerial, special services	32-4561-3			
L2	Coil, oscillator shunt	32-4562-2			
LA1	Loop, antenna	Part of back-and-loop ass'y.			
LS1	Speaker, p-m	36-1627-8			
PC1	Coupling network	30-6001			
PL1	Plug, clock assembly	54-4878-2			
R1	Resistor, oscillator grid, 22,000 ohms	66-3228340*			
R2	Resistor, i-f screen dropping, 4700 ohms	66-2478340*			
R3	Resistor, a-v-c filter 2.2 megohms	66-5228340*			
R4	Resistor, volume control, .5 megohm	33-5565			
R5	Resistor, diode load, 47,000 ohms	66-3478340*			

MISCELLANEOUS

Description	Service Part No.
Cabinet	
White	10940-6
Knobs	
Clock (3)	54-4983-5
Tuning and volume	54-4986-3
Clock	41-2042-2
Back-and-loop assembly	76-7807
Backplate and clip assembly, pilot lamp	76-8720
Scale	
Radio	54-4985
Clock	54-4984
Pointer	56-9846
Clock cover	54-4989
Shaft, tuning	56-9807
Shield, tube	56-5629FA3
Shield, tube base	56-3978FA3
Socket, tube (4)	27-6265
Socket, tube, 12BE6	27-6203-14
Socket assembly, pilot lamp	27-6233-6
Socket assembly, night light	27-6233-110
Spring, drive cord	56-2617
Spring, retaining	28-8610
Drive cord, 25-ft. spool	45-8750*

SPECIFICATIONS

CABINET	Molded plastic
CIRCUIT	Four-tube superheterodyne (plus rectifier)
FREQUENCY RANGE	
Standard Broadcast	540 kc. to 1620 kc.
Special Services	1700 kc. to 3400 kc.
AUDIO OUTPUT1 watt
OPERATING VOLTAGE	105 to 120 volts, a.c. or d.c.
POWER CONSUMPTION	30 watts
AERIAL	High-impedance loop
INTERMEDIATE FREQUENCY	455 kc.
PHILCO TUBES	12BE6 converter, 12BA6 i-f amplifier, 12AV6 det.-a.v.c.-1st audio, 35C5 output, 35W4 rectifier

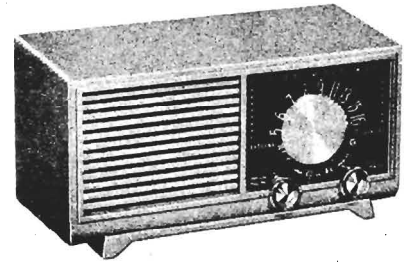

MODEL B574, CODE 121

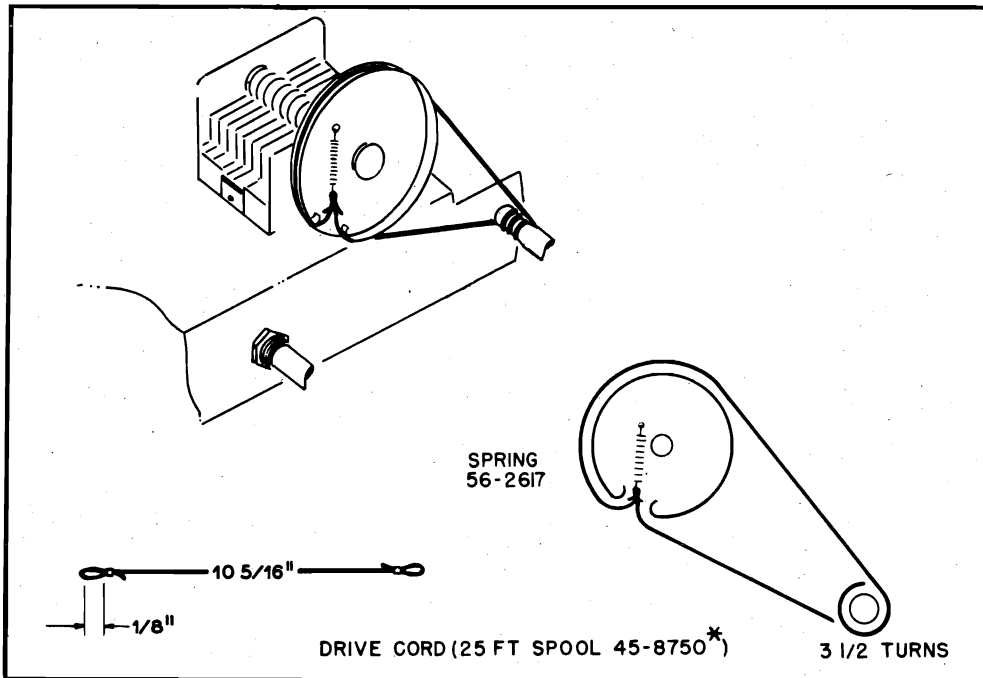

Figure 1. Dial-Cord Installation Details

ALIGNMENT PROCEDURE

RADIO CONTROLS—Set volume control to maximum. Set tuning control and band switch, SW1, as indicated in chart.

OUTPUT METER—Connect across voice-coil terminals.

SIGNAL GENERATOR—Connect generator and set frequency as indicated in chart. Use modulated output.

OUTPUT LEVEL—During alignment, adjust signal-generator output to hold output-meter reading below 1.25 volts.

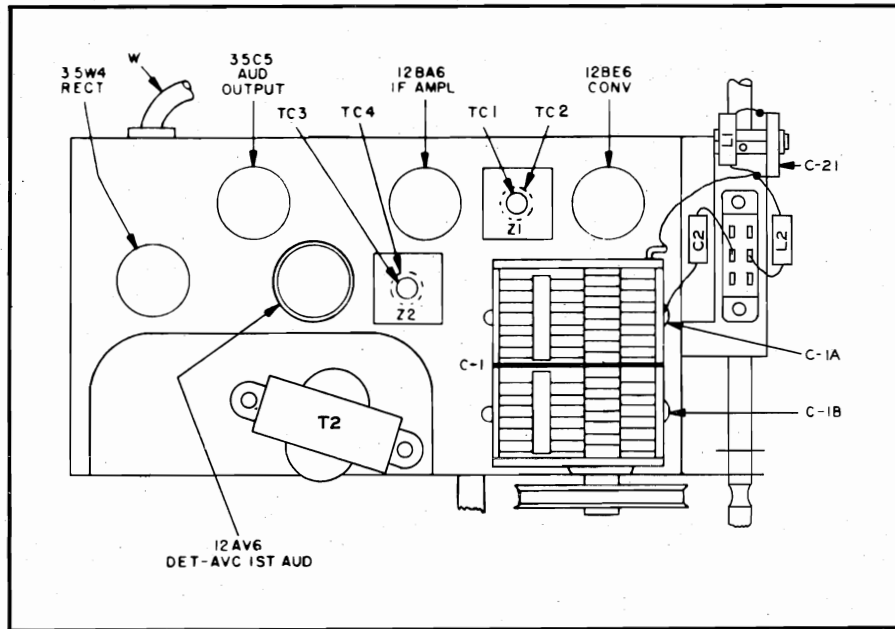

Figure 2. Top View, Showing Trimmer Locations

ALIGNMENT CHART

STEP	SIGNAL GENERATOR		RADIO			ADJUST
	CONNECTION TO RADIO	DIAL SETTING	DIAL SETTING	BAND SWITCH SETTING	SPECIAL INSTRUCTIONS	
1	Ground lead to B-; output lead through a .1- μ f. condenser to grid (pin 7) of 12BE6.	455 kc.	Tuning gang fully open.	Broadcast	Adjust tuning cores, in order given, for maximum output. (TC1 and TC3 are located at top of transformers.)	TC4—2nd i-f sec. TC3—2nd i-f pri. TC2—1st i-f sec. TC1—1st i-f pri.
2	Radiating loop (see NOTE below).	1620 kc.	*1620 kc.	Broadcast	Adjust trimmer for maximum output.	C1-B osc.
3	Same as step 2.	1500 kc.	1500 kc.	Broadcast	Adjust trimmer for maximum output.	C1-A aerial (broadcast).
4	Same as step 2.	3200 kc.	3200 kc.	Special services	Adjust trimmer for maximum output.	C-21—aerial (special services).

NOTE: Make up a 6-8 turn, 6-inch-diameter loop from insulated wire; connect to signal-generator leads and place near radio loop.

* For proper adjustment of the oscillator trimmer, fully open the tuning gang and insert a .006-inch nonmetallic shim between the heel of the rotor and the top of the stator plates. Close the tuning gang sufficiently to hold the shim in place, and then remove the shim without disturbing the gang setting.

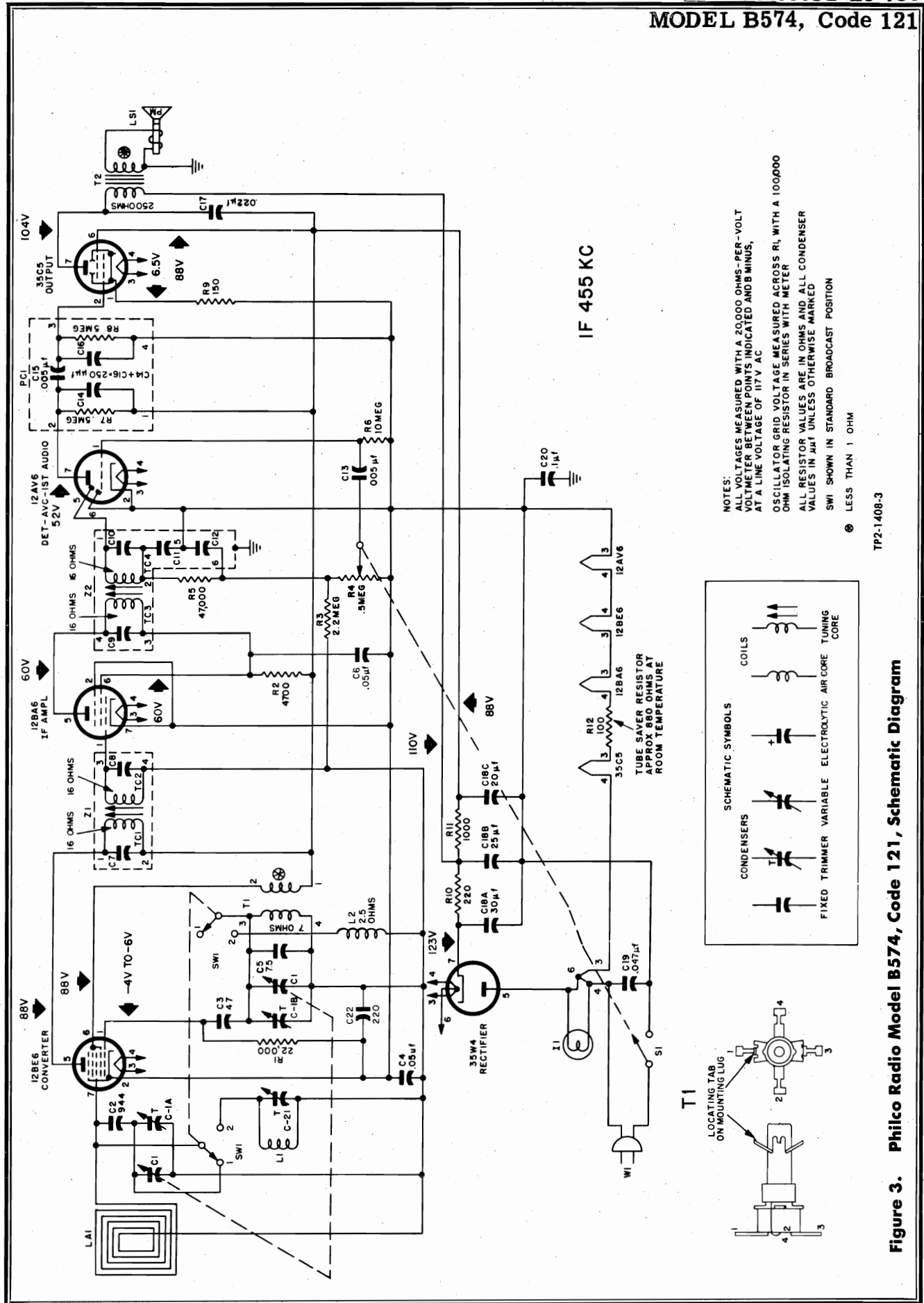

Figure 3. Philco Radio Model B574, Code 121, Schematic Diagram

TP2-1408-3

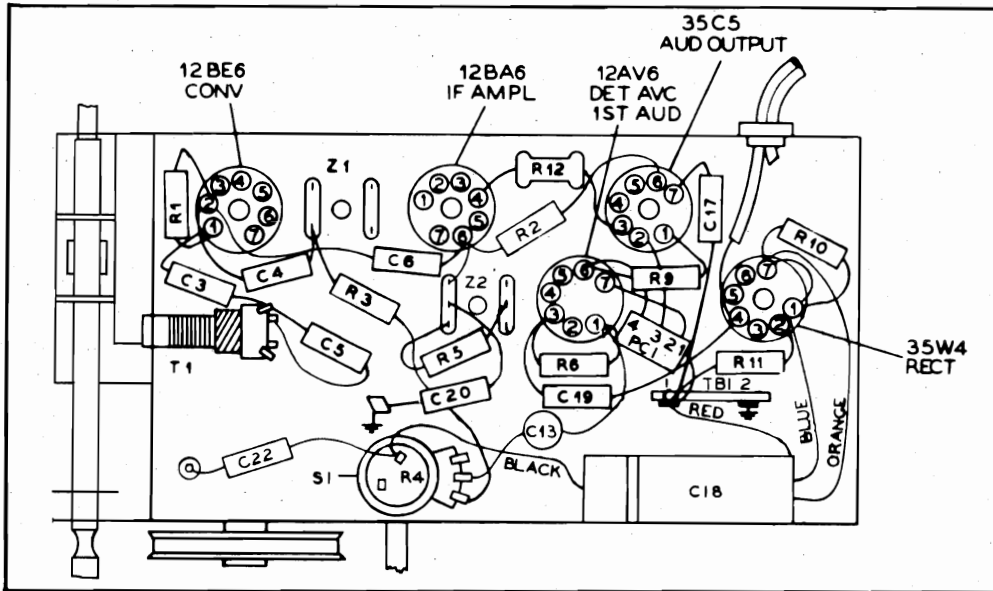

Figure 4. Base View, Showing Symbolized Chassis

TP3-829-1

PARTS LIST

NOTE: Part numbers identified by an asterisk (*) are general replacement items. These numbers may not be identical with those on factory parts. Also, the electrical values of some replacement items may differ from the values indicated in the schematic diagram and parts list. The values substituted in any case are so chosen that the operation will be unchanged. When ordering replacements, use only the "Service Part No."

Reference Symbol	Description	Service Part No.
C1	Condenser, tuning gang	31-2751-14
C1A	Condenser, aerial trimmer	Part of C1
C1B	Condenser, osc. trimmer	Part of C1
C2	Condenser, aerial series tracker, 944 μ f.	30-1220-65
C3	Condenser, oscillator grid, 47. μ f.	30-1230-4
C4	Condenser, a-v-c by-pass, .05 μ f.	45-3505-28*
C5	Condenser, drift compensation, 7.5 μ f.	30-1224-83
C6	Condenser, screen by-pass, .05 μ f.	45-3505-28*
C7	Condenser, i-f tuning	Part of Z1
C8	Condenser, i-f tuning	Part of Z1
C9	Condenser, i-f tuning	Part of Z2
C10	Condenser, i-f tuning	Part of Z2
C11	Condenser, detector filtering	Part of Z2
C12	Condenser, detector filtering	Part of Z2
C13	Condenser, audio coupling, .005 μ f.	30-1238-1
C14	Condenser, plate by-pass	Part of PC1
C15	Condenser, audio coupling, .005 μ f.	Part of PC1
C16	Condenser, compensating	Part of PC1
C17	Condenser, tone compensation, .022 μ f.	45-3505-43*
C18	Condenser, electrolytic, 3-section	30-2575-34
C18A	Condenser, filter, 30 μ f., 150v	Part of C18
C18B	Condenser, filter, 25 μ f., 150v	Part of C18
C18C	Condenser, filter, 20 μ f., 150v	Part of C18
C19	Condenser, line by-pass, .047 μ f.	30-4650-45
C20	Condenser, B- to chassis, .1 μ f.	45-3505-47*
C21	Condenser, trimmer, special service	31-6473-32
I1	Lamp, pilot	34-2068
LA1	Loop, aerial	Part of back-and-loop ass'y.
L1	Coil, antenna, special services	32-4561-3
L2	Coil, oscillator shunt	32-4562-2
LS1	Speaker, p-m	36-1627-8
PC1	Printed circuit	30-6001
R1	Resistor, oscillator grid, 22,000 ohms	66-3228340*
R2	Resistor, i-f screen dropping, 4700 ohm.	66-2478340*

Reference Symbol	Description	Service Part No.
R3	Resistor, a-v-c filter, 2.2 megohms	66-5228340*
R4	Resistor, volume control	33-5566-41
R5	Resistor, diode load, 47,000 ohms	66-3478340*
R6	Resistor, grid return, 10 megohms	66-6108340*
R7	Resistor, plate load, 500,000 ohms	Part of PC1
R8	Resistor, grid return, 500,000 ohms	Part of PC1
R9	Resistor, cathode bias, 150 ohms	66-1158340*
R10	Resistor, B plus filter, 220 ohms	66-1224340*
R11	Resistor, B plus filter, 1000 ohms	66-2108340*
R12	Resistor, tube saver, 100 ohms	33-1343-3
S1	Switch, off-on	Part of R4
SW1	Switch, broadcast-special services	42-1796-2
T1	Transformer, oscillator	32-4453-6
T2	Transformer, output	32-8384-4
W1	Line cord	L-2183*
Z1	Transformer, 1st i-f	32-4161A
Z2	Transformer, 2nd i-f	32-4240A

MISCELLANEOUS

Description	Service Part No.
Cabinet, spruce	10926-29
Back-and-loop ass'y.	76-8362-1
Knob (2)	54-4773-3
Drive cord, 25-foot spool	45-8750
Pointer, dial	28-9502FCP
Shaft, tuning	28-9475FA11
Socket ass'y., pilot lamp	27-6233-30
Socket, 7-pin miniature, 12AV6	27-6233-14
Socket, 7-pin miniature, 12BE6, 12BA6	27-6265
Socket, 7-pin miniature, 35C5, 35W4	27-6265-2
Spring, retaining (3)	1W60980FE7
Spring, drive cord	56-2617
Bracket, switch operating	28-9473FA3
Bracket, switch mounting	28-9474FA3
Switch bracket and padder ass'y.	76-8477

SPECIFICATIONS

CABINET Molded plastic
 CIRCUIT Four-tube superheterodyne (plus rectifier)
 FREQUENCY RANGE
 Standard Broadcast 540 kc. to 1620 kc.
 AUDIO OUTPUT 1 watt
 OPERATING VOLTAGE 105 to 120 volts, a.c. or d.c.
 POWER CONSUMPTION 30 watts
 AERIAL High-impedance loop
 INTERMEDIATE FREQUENCY 455 kc.
 PHILCO TUBES 12BE6 converter, 12BA6 i-f amplifier,
 12AV6 det.-a.v.c.-1st audio, 35C5 output, 35W4 rectifier

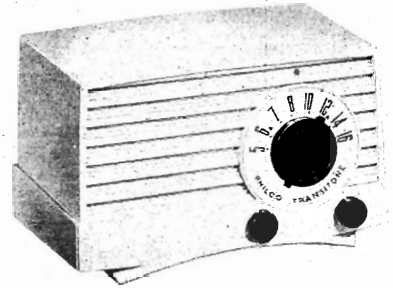

MODEL B570

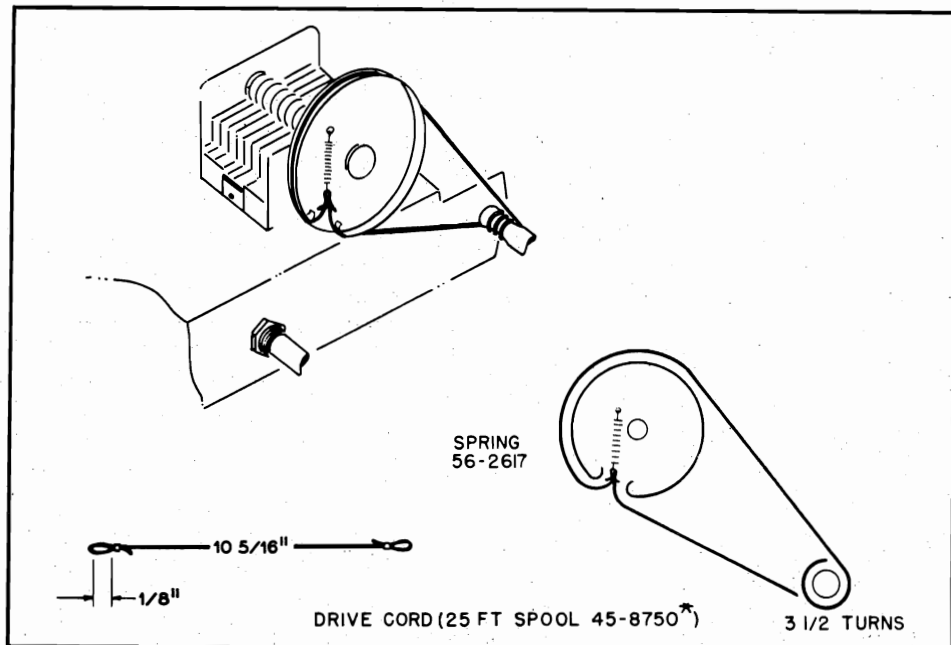

TP3-831

Figure 1. Dial-Cord Installation Details

PR-2542

ALIGNMENT PROCEDURE

RADIO CONTROLS—Set volume control to maximum. Set tuning control and band switch, SW1, as indicated in chart.

OUTPUT METER—Connect across voice-coil terminals.

SIGNAL GENERATOR—Connect generator and set frequency as indicated in chart. Use modulated output.

OUTPUT LEVEL—During alignment, adjust signal-generator output to hold output-meter reading below 1.25 volts.

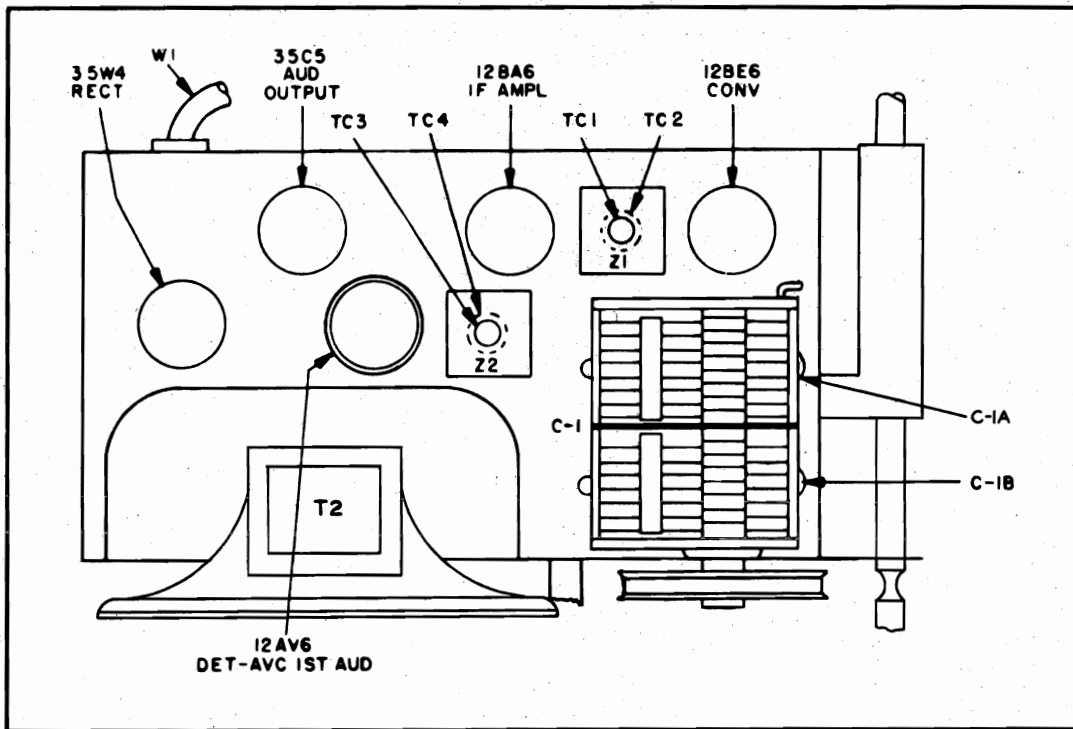

TP3-829-A

Figure 2. Top View, Showing Trimmer Locations

ALIGNMENT CHART

STEP	SIGNAL GENERATOR		RADIO			ADJUST
	CONNECTION TO RADIO	DIAL SETTING	DIAL SETTING	BAND SWITCH SETTING	SPECIAL INSTRUCTIONS	
1	Ground lead to B-; output lead through a .1- μ f. condenser to grid (pin 7) of 12BE6.	455 kc.	Tuning gang fully open.	Broadcast	Adjust tuning cores, in order given, for maximum output. (TC1 and TC3 are located at top of transformers).	TC4—2nd i-f sec. TC3—2nd i-f pri. TC2—1st i-f sec. TC1—1st i-f pri.
2	Radiating loop (see NOTE below).	1620 kc.	*1620 kc.	Broadcast	Adjust trimmer for maximum output.	C1-B osc.
3	Same as step 2.	1500 kc.	1500 kc.	Broadcast	Adjust trimmer for maximum output.	C1-A aerial (broadcast).

NOTE: Make up a 6-8 turn, 6-inch-diameter loop from insulated wire; connect to signal-generator leads and place near radio loop.

* For proper adjustment of the oscillator trimmer, fully open the tuning gang and insert a .006-inch nonmetallic shim between the heel of the rotor and the top of the stator plates. Close the tuning gang sufficiently to hold the shim in place, and then remove the shim without disturbing the gang setting.

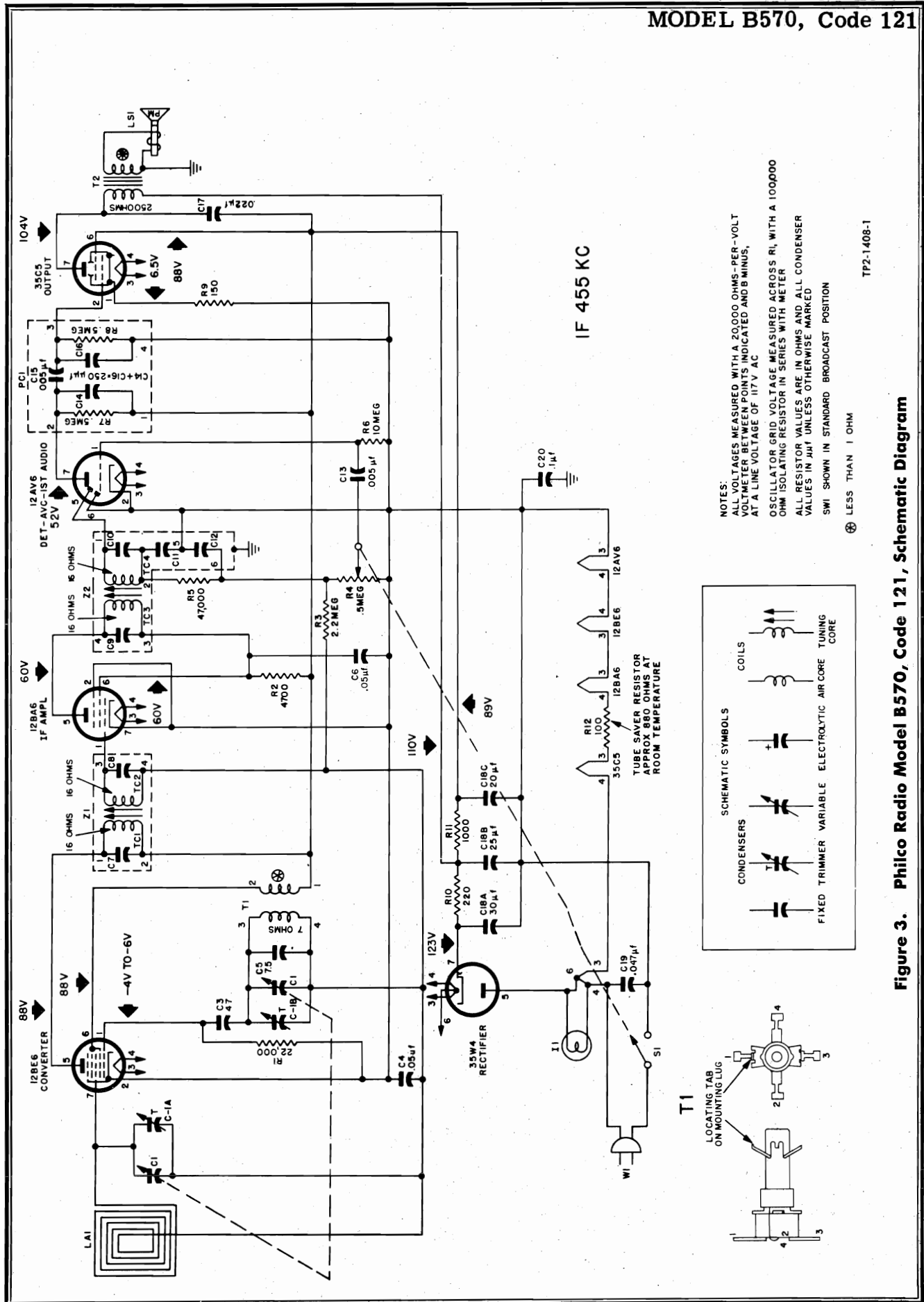

NOTES:
 ALL VOLTAGES MEASURED WITH A 20,000 OHMS-PER-VOLT
 VOLTMETER BETWEEN POINTS INDICATED AND B MINUS,
 AT A LINE VOLTAGE OF 117 V AC
 OSCILLATOR GRID VOLTAGE MEASURED ACROSS R1 WITH A 100,000
 OHM ISOLATING RESISTOR IN SERIES WITH METER
 ALL RESISTOR VALUES ARE IN OHMS AND ALL CONDENSER
 VALUES IN μ F UNLESS OTHERWISE MARKED
 SWI SHOWN IN STANDARD BROADCAST POSITION

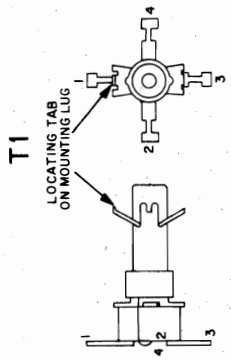
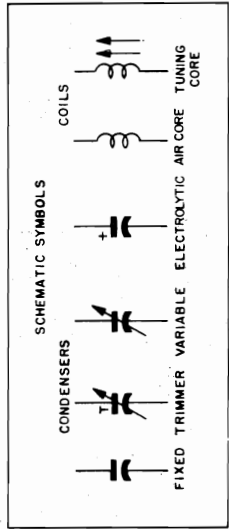

⊕ LESS THAN 1 OHM
 TP2-1408-1

Figure 3. Philco Radio Model B570, Code 121, Schematic Diagram

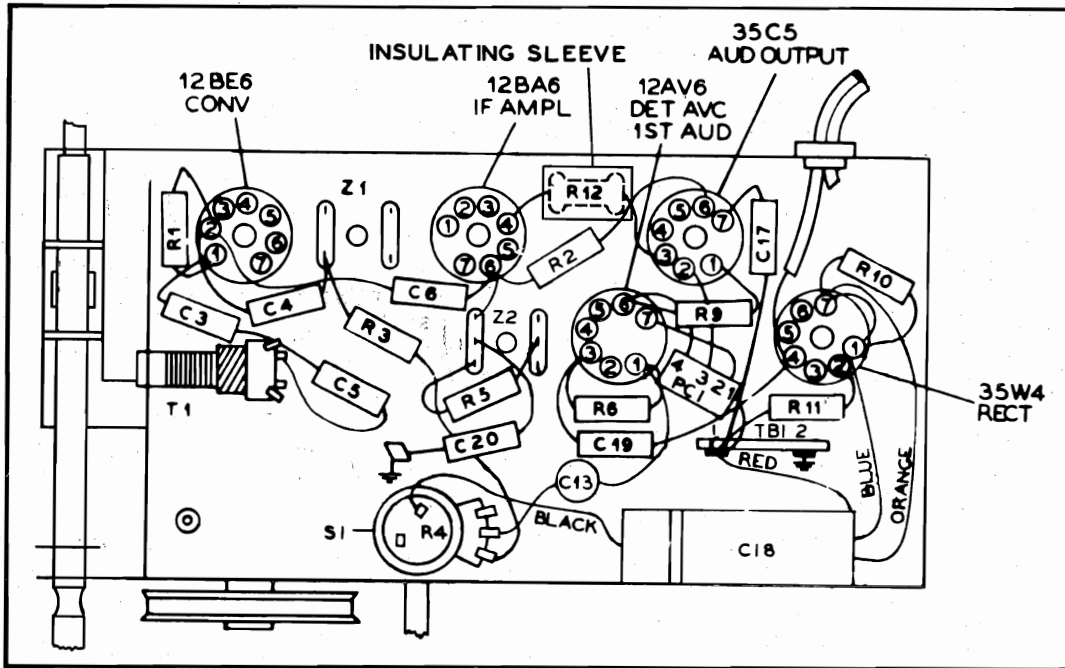

Figure 4. Base View, Showing Symbolized Chassis

TP3-835

PARTS LIST

NOTE: Part numbers identified by an asterisk (*) are general replacement items. These numbers may not be identical with those on factory parts. Also, the electrical values of some replacement items may differ from the values indicated in the schematic diagram and parts list. The values substituted in any case are so chosen that the operation will be unchanged. When ordering replacements, use only the "Service Part No."

Reference Symbol	Description	Service Part No.
C1	Condenser, tuning gang	31-2751-14
C1A	Condenser, aerial trimmer	Part of C1
C1B	Condenser, osc. trimmer	Part of C1
C3	Condenser, oscillator grid, 47 μ f.	30-1230-4
C4	Condenser, a-v-c by-pass, .05 μ f.	45-3505-28*
C5	Condenser, drift compensation 7.5 μ f.	30-1224-83
C6	Condenser, screen by-pass, .05 μ f.	45-3505-28*
C7	Condenser, i-f tuning	Part of Z1
C8	Condenser, i-f tuning	Part of Z1
C9	Condenser, i-f tuning	Part of Z2
C10	Condenser, i-f tuning	Part of Z2
C11	Condenser, detector filtering	Part of Z2
C12	Condenser, detector filtering	Part of Z2
C13	Condenser, audio coupling, .005 μ f.	30-1238-1
C14	Condenser, plate by-pass	Part of PC1
C15	Condenser, audio coupling, .005 μ f.	Part of PC1
C16	Condenser, compensating	Part of PC1
C17	Condenser, tone compensation, .022 μ f.	45-3505-43*
C18	Condenser, electrolytic, 3-section	30-2575-34
C18A	Condenser, filter, 30 μ f., 150v	Part of C18
C18B	Condenser, filter, 25 μ f., 150v	Part of C18
C18C	Condenser, filter, 20 μ f., 150v	Part of C18
C19	Condenser, line by-pass, .05 μ f.	30-4650-45
C20	Condenser, B- to chassis, .1 μ f.	45-3505-47*
II	Lamp, pilot	34-2068
LA1	Loop, aerial	Part of back-and-loop ass'y.
LS1	Speaker, p-m	36-1627-8
PC1	Printed circuit	30-6001
R1	Resistor, oscillator grid, 22000 ohms	66-3228340*
R2	Resistor, i-f screen dropping, 4700 ohms	66-2478340*
R3	Resistor, a-v-c filter, 2.2 megohms	66-5228340*
R4	Resistor, volume control	33-5566-41
R5	Resistor, diode load, 47,000 ohms	66-3478340*
R6	Resistor, grid return, 10 megohms	66-6108340*
R7	Resistor, plate load, 500,000 ohms	Part of PC1

Reference Symbol	Description	Service Part No.
R8	Resistor, grid return, 500,000 ohms	Part of PC1
R9	Resistor, cathode bias, 150 ohms	66-1158340*
R10	Resistor, B plus filter, 220 ohms	66-1224340*
R11	Resistor, B plus filter, 1000 ohms	66-2108340*
R12	Resistor, tube saver, 100 ohms	33-1343-3
S1	Switch, off-on	Part of R4
T1	Transformer, oscillator	32-4453-6
T2	Transformer, output	32-8384*
W1	Line cord	L-2183*
Z1	Transformer, 1st i-f	32-4161A
Z2	Transformer, 2nd i-f	32-4240A

MISCELLANEOUS

Description	Service Part No.
Cabinet	
Cardinal	10990
Sand	10990-1
Back-and-loop ass'y.	76-8515-1
Knob (2)	54-6062
Drive cord, 25-foot spool	45-8750
Pointer, dial	
Cardinal cabinet	54-6061
Sand cabinet	54-6061
Shaft, tuning	28-9475FA11
Socket ass'y., pilot lamp	27-6233-80
Socket, 7-pin miniature, 12AV6	27-6303-14
Socket, 7-pin miniature, 12BE6, 12BA6	27-6265
Socket, 7-pin miniature, 35C5, 35W4	27-6265-2
Spring, retaining (3)	1W60980FE7
Spring, drive cord	56-2617
Bracket, switch operating	28-9473FA3
Bracket, switch mounting	28-9474FA3
Switch bracket and padder ass'y.	76-8477

SPECIFICATIONS

CABINET Molded phenolic
 CIRCUIT Four-tube superheterodyne (plus rectifier)
 FREQUENCY RANGE 540—1620 kc.
 AUDIO OUTPUT 1 watt
 OPERATING VOLTAGE 117 volts, a.c.
 POWER CONSUMPTION 30 watts
 ANTENNA High-impedance loop
 INTERMEDIATE FREQUENCY 455 kc.
 PHILCO TUBES...12BE6, converter; 12BA6, i-f amplifier;
 12AV6, det.—a.v.c.—1st audio; 35C5,
 output; 35W4, rectifier



MODEL B710

NOTE: The antenna is mounted on the cabinet back. When removing the cabinet back, use care to avoid breaking the antenna leads.

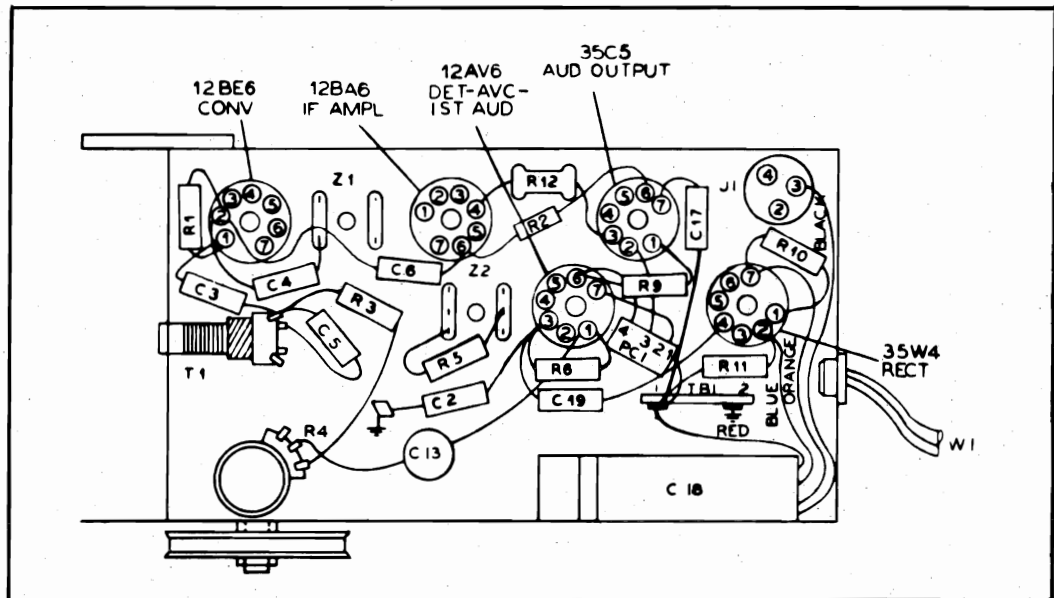

Figure 1. Base View, Showing Parts Placement

MODEL B710

ALIGNMENT PROCEDURE

RADIO CONTROLS—Set volume control to maximum. Set tuning control as indicated in chart.

SIGNAL GENERATOR—Connect generator and set frequency as indicated in chart. Use modulated output.

OUTPUT METER—Connect across voice-coil terminals.

OUTPUT LEVEL—During alignment, adjust signal-generator output to hold output-meter reading below 1.25 volts.

ALIGNMENT CHART

STEP	SIGNAL GENERATOR		RADIO		ADJUST
	CONNECTION TO RADIO	DIAL SETTING	DIAL SETTING	SPECIAL INSTRUCTIONS	
1	Ground lead to B-; output lead through a .1- μ f. condenser to grid (pin 7) of 12BE6.	455 kc.	Tuning gang fully open.	Adjust tuning cores, in order given, for maximum output. (TC1 and TC3 are located at top of transformers.)	TC4—2nd i-f sec. TC3—2nd i-f pri. TC2—1st i-f sec. TC1—1st i-f pri.
2	Radiating loop (see note below).	1620 kc.	1620 kc.*	Adjust trimmer for maximum output.	C1B—osc.
3	Same as step 2.	1500 kc.	1500 kc.†	Adjust trimmer for maximum output.	C1A—antenna

NOTE: make a 6–8 turn, 6-inch-diameter loop from insulated wire; connect to signal-generator leads, and place about 1 foot from radio loop. The position of the radio loop with respect to the chassis should be approximately the same as when both are mounted in the cabinet.

* To set the tuning gang to 1620 kc., fully open the gang and insert a .006-inch, nonmetallic shim between the heel of the rotor and the top of the stator plates. Close the gang sufficiently to hold the shim in place, and then remove the shim without disturbing the gang setting.

† To set the radio to 1500 kc., place chassis in cabinet, attach knob to indicate previous setting of 1620 kc., and tune until pointer indicates 1500 kc. Then remove knob and take chassis from cabinet without disturbing gang setting.

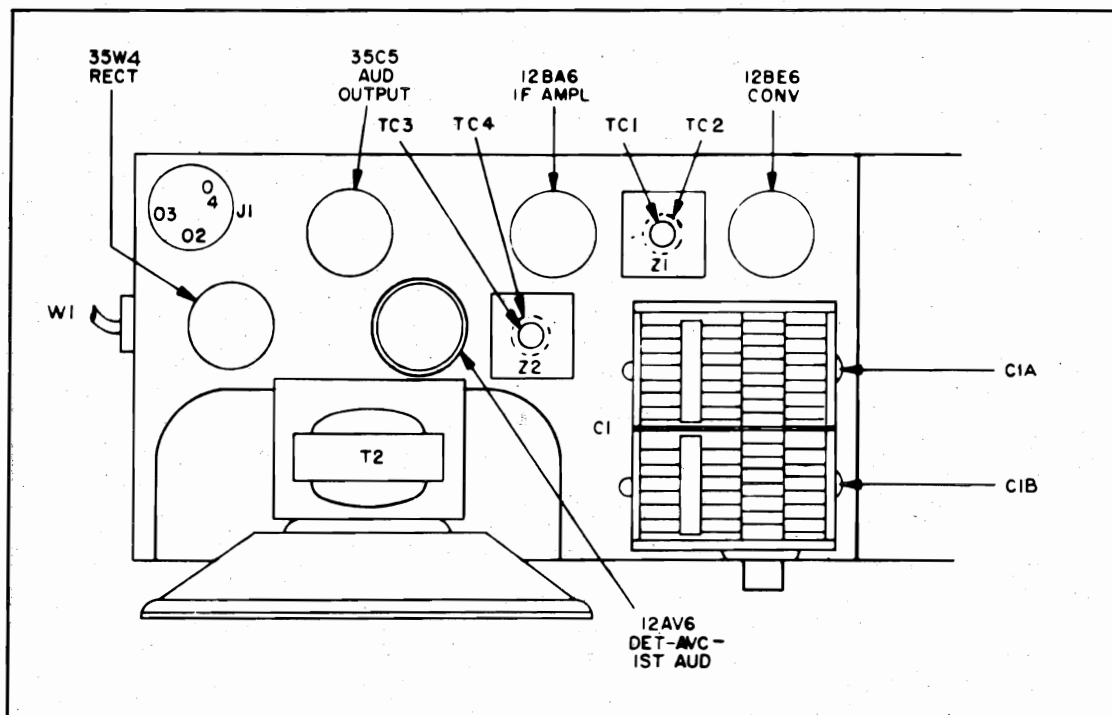
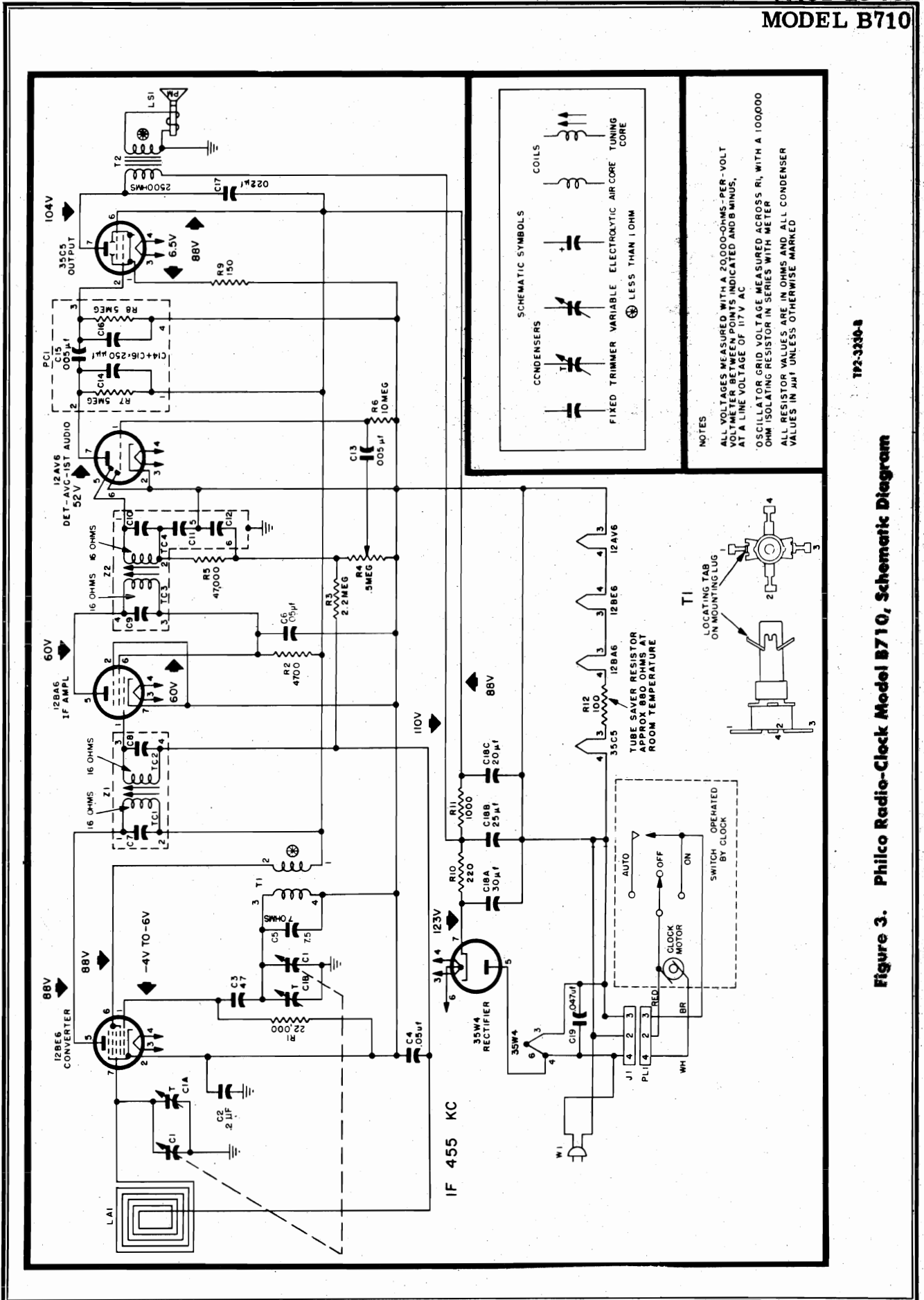

Figure 2. Top View, Showing Tuning Adjustments

TP3-830



1P2-3230-3

Figure 3. Philco Radio-Clock Model B710, Schematic Diagram

MODEL B710

PARTS LIST

NOTE: Part numbers identified by an asterisk (*) are general replacement items. These numbers may not be identical with those on factory parts. Also, the electrical values of some replacement items may differ from the values indicated in the schematic diagram and parts list. The values substituted in any case are so chosen that the operation will be unchanged. When ordering replacements, use only the "Service Part No."

Reference Symbol	Description	Service Part No.	Reference Symbol	Description	Service Part No.
C1	Condenser, tuning gang	31-2751-13	R3	Resistor, a-v-c filter, 2.2 megohms	66-5228340*
C1A	Condenser, r-f trimmer	Part of C1	R4	Resistor, volume control, .5 megohm	33-5565
C1B	Condenser, oscillator trimmer	Part of C1	R5	Resistor, diode load, 47,000 ohms	66-3478340*
C2	Condenser, B- to chassis, .2 μ f.	30-4650-49	R6	Resistor, grid return, 10 megohms	66-6108340
C3	Condenser, oscillator grid, 47 μ f.	30-1230-4	R7	Resistor, plate load, 500,000 ohms	Part of PC1
C4	Condenser, a-v-c by-pass, .05 μ f.	30-4650-45*	R8	Resistor, grid return, 500,000 ohms	Part of PC1
C5	Condenser, drift compensation, 7.5 μ f.	30-1224-83	R9	Resistor, cathode bias, 150 ohms	66-1158340*
C6	Condenser, screen by-pass, .05 μ f.	30-4650-45*	R10	Resistor, B plus filter, 220 ohms, 1 watt	66-1224340*
C7	Condenser, i-f tuning	Part of Z1	R11	Resistor, B plus filter, 1000 ohms	66-2108340*
C8	Condenser, i-f tuning	Part of Z1	R12	Resistor, tube saver, 100 ohms	33-1343-3
C9	Condenser, i-f tuning	Part of Z2	T1	Transformer, oscillator	33-4453-6
C10	Condenser, i-f tuning	Part of Z2	T2	Transformer, output	Part of LS1
C11	Condenser, detector filtering	Part of Z2	W1	Line cord	L2183*
C12	Condenser, detector filtering	Part of Z2	Z1	Transformer, 1st i-f	32-4161A
C13	Condenser, audio coupling, .005 μ f.	30-1238-1	Z2	Transformer, 2nd i-f	32-4240A
C14	Condenser, plate by-pass	Part of PC1			
C15	Condenser, audio coupling, .005 μ f.	Part of PC1			
C16	Condenser, compensating	Part of PC1			
C17	Condenser, tone compensation, .022 μ f.	30-4650-43*			
C18	Condenser, electrolytic, 3-section	45-3037			
C18A	Condenser, filter, 30 μ f., 150v	Part of C18			
C18B	Condenser, filter, 25 μ f., 150v	Part of C18			
C18C	Condenser, filter, 20 μ f., 150v	Part of C18			
C19	Condenser, line by-pass, .05 μ f.	30-4650-45*			
J1	Jack clock	27-6273			
LA1	Loop	Part of cabinet back			
LS1	Speaker ass'y., p-m	36-1627-23			
PC1	Printed circuit	30-6001			
PL1	Plug, clock assembly	54-4878-2			
R1	Resistor, oscillator grid, 22,000 ohms.....	66-3228340*			
R2	Resistor, i-f screen dropping, 4700 ohms	66-2478340*			

MISCELLANEOUS	
Description	Service Part No.
Cabinet	10924-11
Knobs	
Clock (3 required)	54-4983-6
Station selector	54-4978-5
Off-on	54-4815-8
Clock	41-2041-4
Back-and-loop assembly	76-7757-3
Shield, tube	56-5629FA3
Socket, miniature (4 required)	27-6265*
Socket, miniature (12AV6)	27-6203-14
Window, radio dial	54-4977-5

SPECIFICATIONS

CABINET	Molded phenolic
CIRCUIT	Four-tube superheterodyne (plus rectifier)
FREQUENCY RANGE	540—1620 kc.
AUDIO OUTPUT	1 watt
OPERATING VOLTAGE	117 volts, a.c.
POWER CONSUMPTION	30 watts
ANTENNA	High-impedance loop
INTERMEDIATE FREQUENCY	455 kc.
PHILCO TUBES	12BE6, converter; 12BA6, i-f amplifier; 12AV6, det.—a.v.c.—1st audio; 35C5, output; 35W4, rectifier



MODEL B711

NOTE: The antenna is mounted on the cabinet back. When removing the cabinet back, use care to avoid breaking the antenna leads.

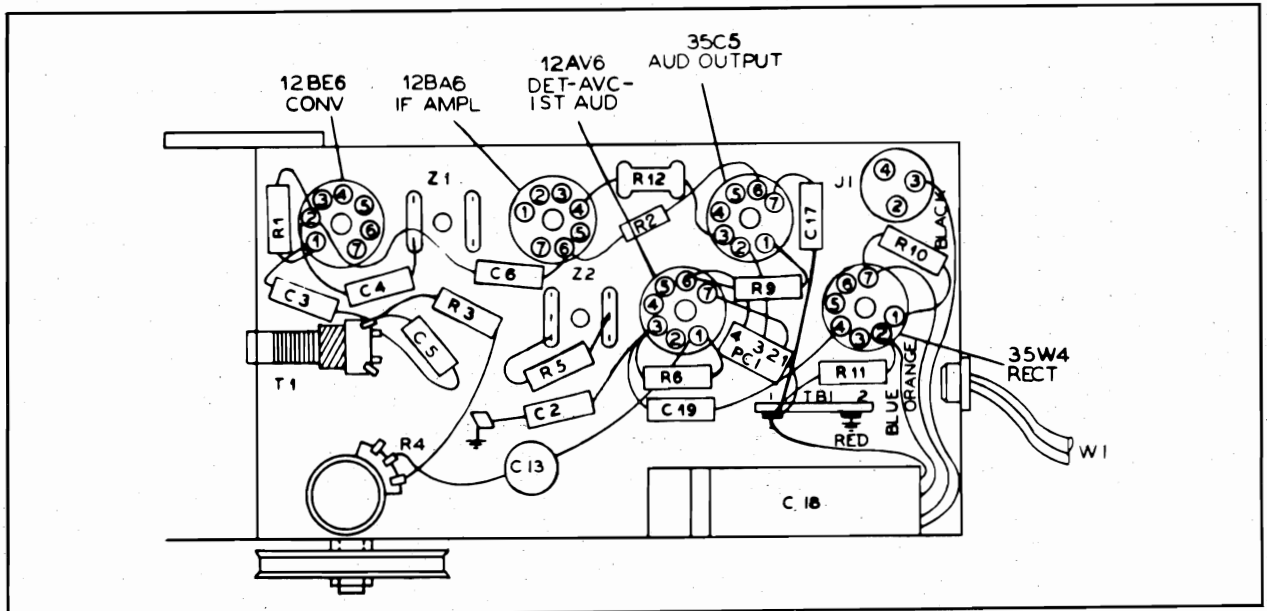

TP3-832-1

Figure 1. Base View, Showing Parts Placement

PR-2540

ALIGNMENT PROCEDURE

RADIO CONTROLS—Set volume control to maximum. Set tuning control as indicated in chart.

OUTPUT METER—Connect across voice-coil terminals.

SIGNAL GENERATOR—Connect generator and set

frequency as indicated in chart. Use modulated output.

OUTPUT LEVEL—During alignment, adjust signal-generator output to hold output-meter reading below 1.25 volts.

ALIGNMENT CHART

STEP	SIGNAL GENERATOR		RADIO		ADJUST
	CONNECTION TO RADIO	DIAL SETTING	DIAL SETTING	SPECIAL INSTRUCTIONS	
1	Ground lead to B-; output lead through a .1- μ f. condenser to grid (pin 7) of 12BE6.	455 kc.	Tuning gang fully open.	Adjust tuning cores, in order given, for maximum output. (TC1 and TC3 are located at top of transformers.)	TC4—2nd i-f sec. TC3—2nd i-f pri. TC2—1st i-f sec. TC1—1st i-f pri.
2	Radiating loop (see note below).	1620 kc.	1620 kc.*	Adjust trimmer for maximum output.	C1B—osc.
3	Same as step 2.	1500 kc.	1500 kc.†	Adjust trimmer for maximum output.	C1A—antenna

NOTE: Make a 6–8 turn, 6-inch-diameter loop from insulated wire; connect to signal-generator leads, and place about 1 foot from radio loop. The position of the radio loop with respect to the chassis should be approximately the same as when both are mounted in the cabinet.

* To set the tuning gang to 1620 kc., fully open the gang and insert a .006-inch, nonmetallic shim between the heel of the rotor and the top of the stator plates. Close the gang sufficiently to hold the shim in place, and then remove the shim without disturbing the gang setting.

† To set the radio to 1500 kc., place chassis in cabinet, attach knob to indicate previous setting of 1620 kc., and tune until pointer indicates 1500 kc. Then remove knob and take chassis from cabinet without disturbing gang setting.

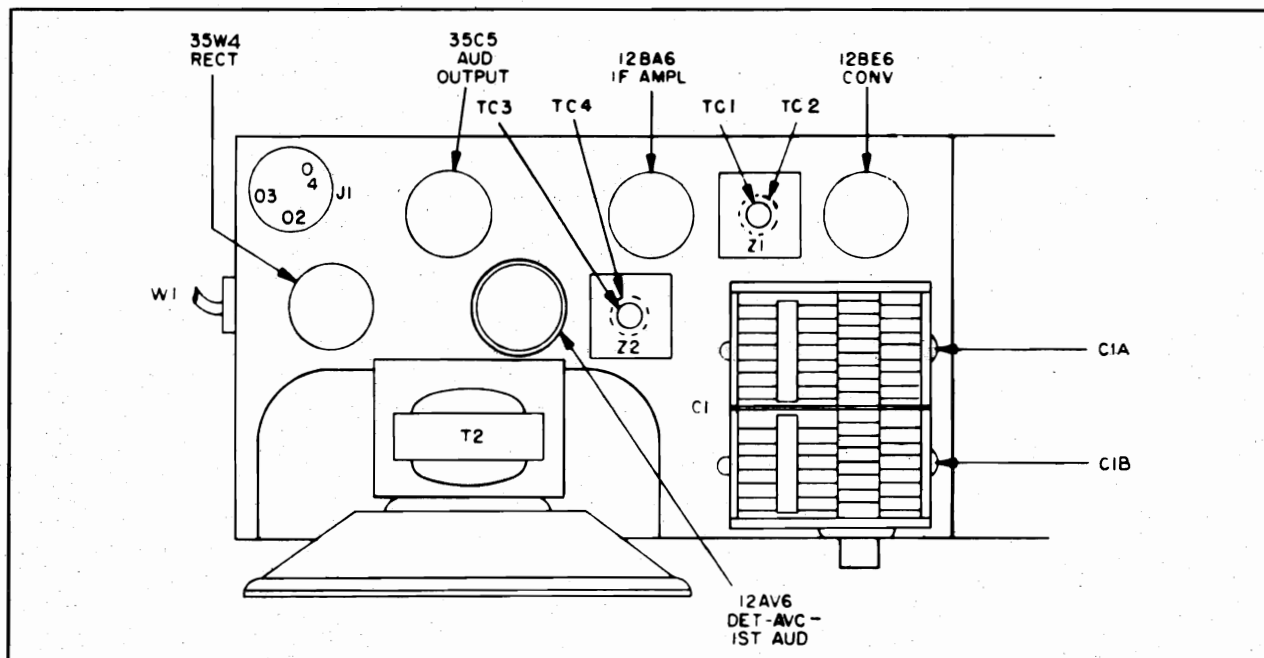

TP3-830-1

Figure 2. Top View, Showing Tuning Adjustments

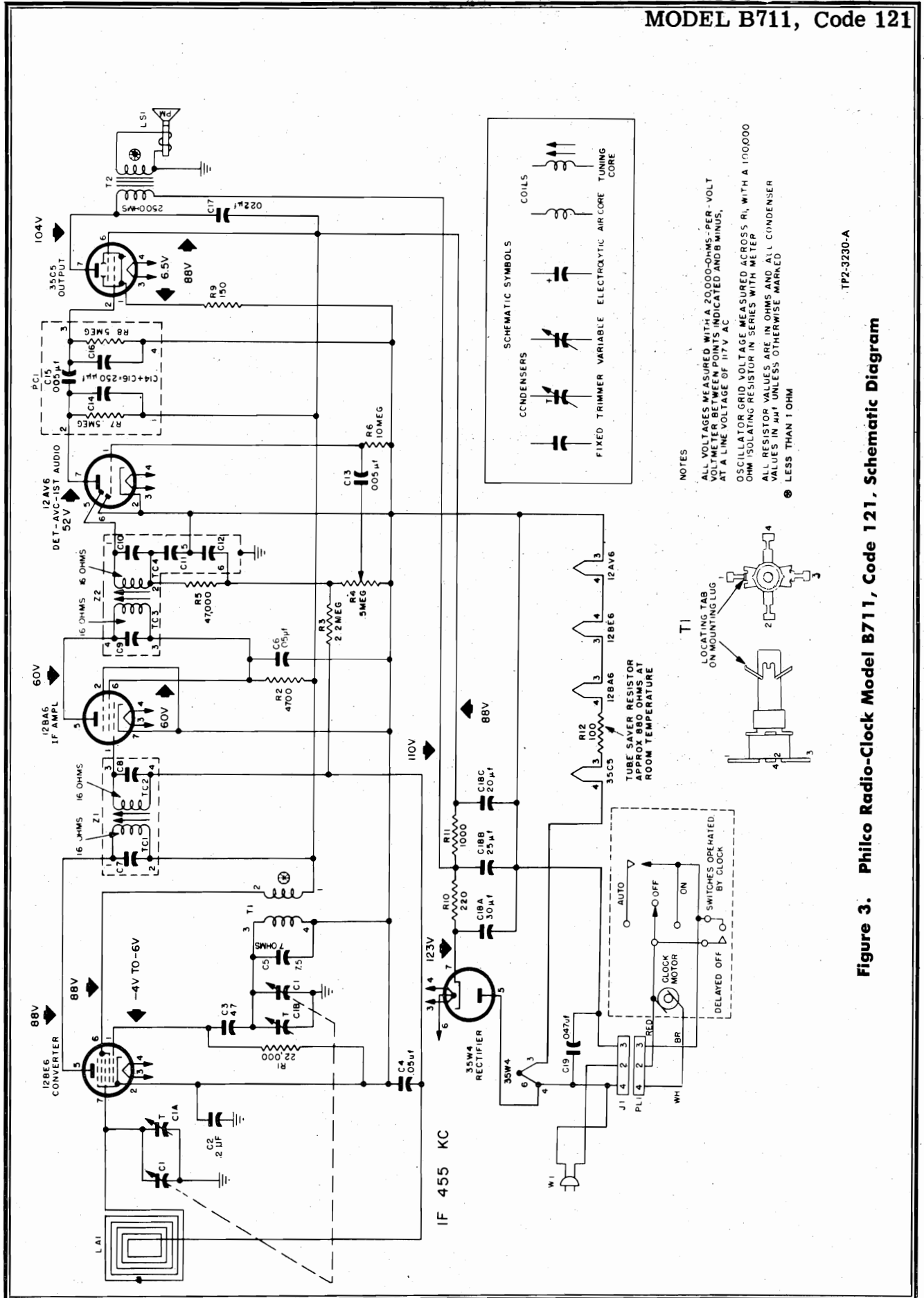

TP2-3230-A

Figure 3. Philco Radio-Clock Model B711, Code 121, Schematic Diagram

PARTS LIST

NOTE: Part numbers identified by an asterisk (*) are general replacement items. These numbers may not be identical with those on factory parts. Also, the electrical values of some replacement items may differ from the values indicated in the schematic diagram and parts list. The values substituted in any case are so chosen that the operation will be unchanged. When ordering replacements, use only the "Service Part No."

Reference Symbol	Description	Service Part No.	Reference Symbol	Description	Service Part No.
C1	Condenser, tuning gang	31-2751-13	R3	Resistor, a-v-c filter, 2.2 megohms	66-5228340*
C1A	Condenser, r-f trimmer	Part of C1	R4	Resistor, volume control, .5 megohm	33-5565
C1B	Condenser, oscillator trimmer	Part of C1	R5	Resistor, diode load, 47,000 ohms	66-3478340*
C2	Condenser, B- to chassis, .2 μ f.	30-4650-49	R6	Resistor, grid return, 10 megohms	66-6108340
C3	Condenser, oscillator grid, 47 μ f.	30-1230-4	R7	Resistor, plate load, 500,000 ohms	Part of PC1
C4	Condenser, a-v-c by-pass, .05 μ f.	30-4650-45*	R8	Resistor, grid return, 500,000 ohms	Part of PC1
C5	Condenser, drift compensation, 7.5 μ f.	30-1224-83	R9	Resistor, cathode bias, 150 ohms	66-1158340*
C6	Condenser, screen by-pass, .05 μ f.	30-4650-45*	R10	Resistor, B plus filter, 220 ohms, 1 watt	66-1224340*
C7	Condenser, i-f tuning	Part of Z1	R11	Resistor, B plus filter, 1000 ohms	66-2108340*
C8	Condenser, i-f tuning	Part of Z1	R12	Resistor, tube saver, 100 ohms	33-1343-3
C9	Condenser, i-f tuning	Part of Z2	T1	Transformer, oscillator	33-4453-6
C10	Condenser i-f tuning	Part of Z2	T2	Transformer, output	Part of LS1
C11	Condenser, detector filtering	Part of Z2	W1	Line cord	L2183*
C12	Condenser, detector filtering	Part of Z2	Z1	Transformer, 1st i-f	32-4161A
C13	Condenser, audio coupling, .005 μ f.	30-1238-1	Z2	Transformer, 2nd i-f	32-4240A
C14	Condenser, plate by-pass	Part of PC1	MISCELLANEOUS		
C15	Condenser, audio coupling, .005 μ f.	Part of PC1			
C16	Condenser, compensating	Part of PC1			
C17	Condenser, tone compensation, .022 μ f.	30-4650-43*			
C18	Condenser, electrolytic, 3-section	45-3037			
C18A	Condenser, filter, 30 μ f., 150v	Part of C18			
C18B	Condenser, filter, 25 μ f., 150v	Part of C18			
C18C	Condenser, filter, 20 μ f., 150v	Part of C18			
C19	Condenser, line by-pass, .047 μ f.	30-4650-45*			
J1	Jack, clock	27-6273			
LA1	Loop	Part of cabinet back			
LS1	Speaker ass'y., p-m	36-1627-23			
PC1	Printed circuit	30-6001			
PL1	Plug, clock assembly	54-4878-2			
R1	Resistor, oscillator grid, 22,000 ohms	66-3228340*			
R2	Resistor, i-f screen dropping, 4700 ohms	66-2478340*			
			MISCELLANEOUS		
			Description	Service Part No.	
			Cabinet	10924-12	
			Knobs		
			Clock (4 required)	54-4983-6	
			Station selector	54-4978-5	
			Off-on	54-4815-8	
			Clock	41-2041-6	
			Back-and-loop assembly	76-7757-3	
			Shield, tube	56-5629FA3	
			Socket, miniature (4 required)	27-6265*	
			Socket, miniature, 12BE6	27-6203-14	
			Window, radio dial	54-4977-5	

SPECIFICATIONS

CABINET.....	Plastic portable
CIRCUIT.....	Four-tube superheterodyne
AUDIO OUTPUT.....	75 milliwatts
OPERATING VOLTAGE.....	1.5-volt "A" battery and 75-volt "B" battery.
POWER CONSUMPTION.....	10 ma. from 75-volt "B" battery 260 ma. from 1.5-volt "A" battery
ANTENNA.....	Magnecor high-impedance
INTERMEDIATE FREQUENCY.....	455 kc.
PHILCO TUBES.....	1R5 converter, 1U4 i-f amplifier, 1U5 detector-a.v.c. 1st audio, 3V4 output
BATTERY TYPE.....	PI44 "B" battery P77 "A" battery



MODEL B650

ALIGNMENT PROCEDURE

GENERAL—Allow the set and the test equipment to warm up for fifteen minutes before starting the alignment procedure.

TUNING DIAL—Before proceeding with the alignment, set the index mark on the tuning dial to coincide with the index mark located on the chassis. See figure 1. The plates of the tuning condensers will be fully meshed.

OUTPUT INDICATOR—Connect the output indicator (a 1000-ohm-per-volt, a-c voltmeter, or an oscilloscope) across the voice-coil terminals.

SIGNAL GENERATOR—Use an AM r-f signal generator. Connect the ground lead to the chassis, and connect the output lead as indicated in the alignment chart.

OUTPUT LEVEL—Attenuate the signal-generator output throughout the alignment so as to maintain the output level below .3 volt.

RADIO CONTROLS—Set the volume control to maximum. Set the tuning control as indicated in the alignment chart. Set the Battery Saver Switch to the HI position.

MODEL B650

ALIGNMENT CHART

STEP	SIGNAL GENERATOR		RADIO		ADJUST
	CONNECTION TO RADIO	DIAL SETTING	DIAL SETTING	SPECIAL INSTRUCTIONS	
1	Connect signal generator through a .1- μ f. condenser to pin 6 (converter grid) of 1R5.	455 kc.	Tuning gang fully open.	Adjust for maximum output in order given.	TC3—2nd i-f sec. TC2—1st i-f sec. TC1—1st i-f pri.
2	Use radiating loop. (See NOTE 1 below.)	1620 kc.	1620 kc. (See NOTE 2 below.)	Adjust for maximum output.	C1B—osc. trimmer
3	Same as step 2.	1400 kc.	1400 kc. (See NOTE 2 below.)	Adjust for maximum output.	C1A—antenna trimmer
4	Same as step 2.	600 kc.	600 kc. (See NOTE 2 below.)	Adjust for maximum output. Rock tuning gang while making this adjustment.	L1—antenna adjusting winding
5	Repeat steps 2, 3, and 4 until no further improvement is obtained.				

NOTE 1: Use a 6-to-8-turn, 6-inch-diameter loop made up of insulated wire. Connect to generator terminals, and place about one foot from radio loop.

NOTE 2: The tuning condenser can be set to the proper frequency by turning the tuning dial until the frequency setting indicated in the chart coincides with the index mark on the chassis. See figure 1.

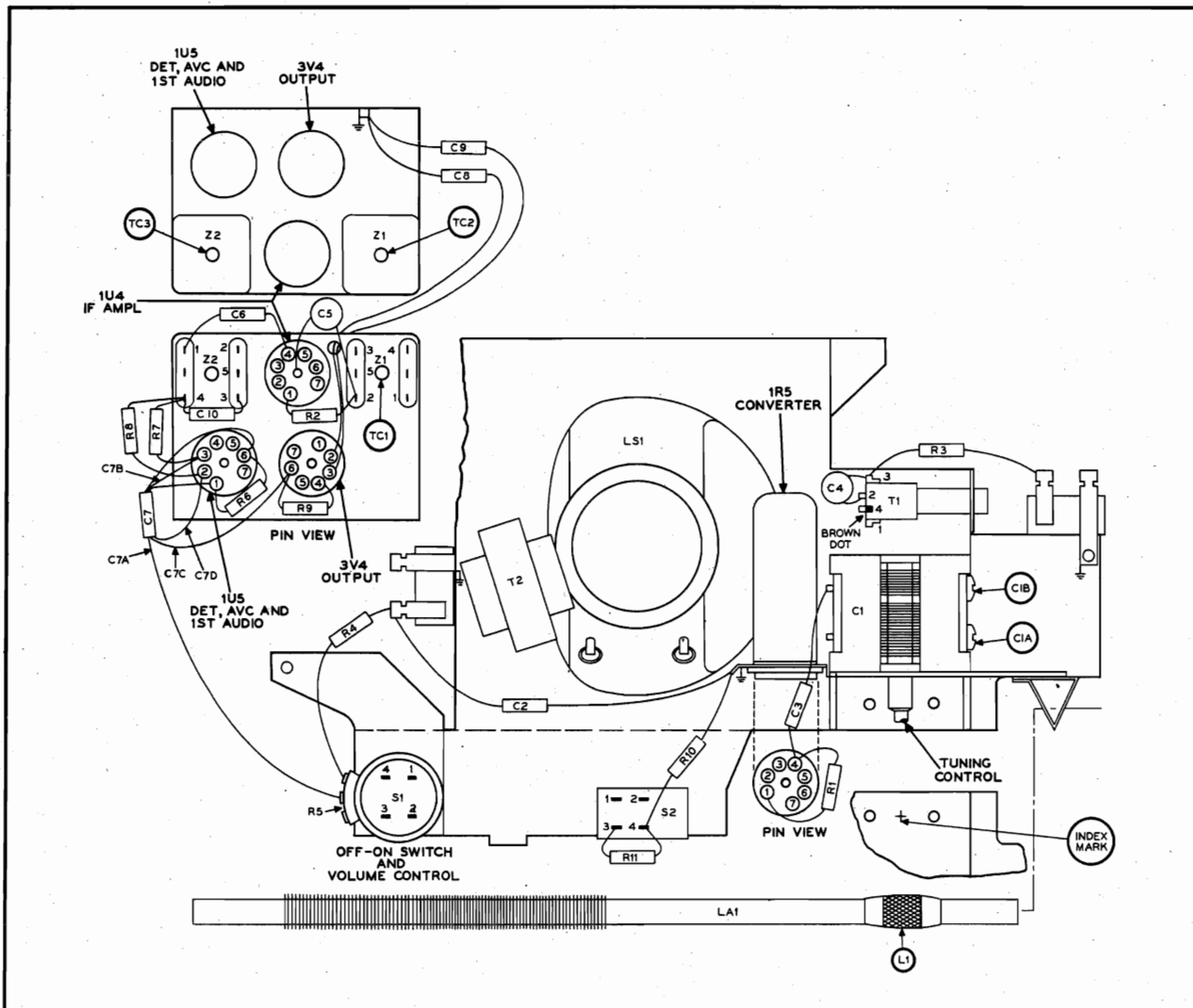
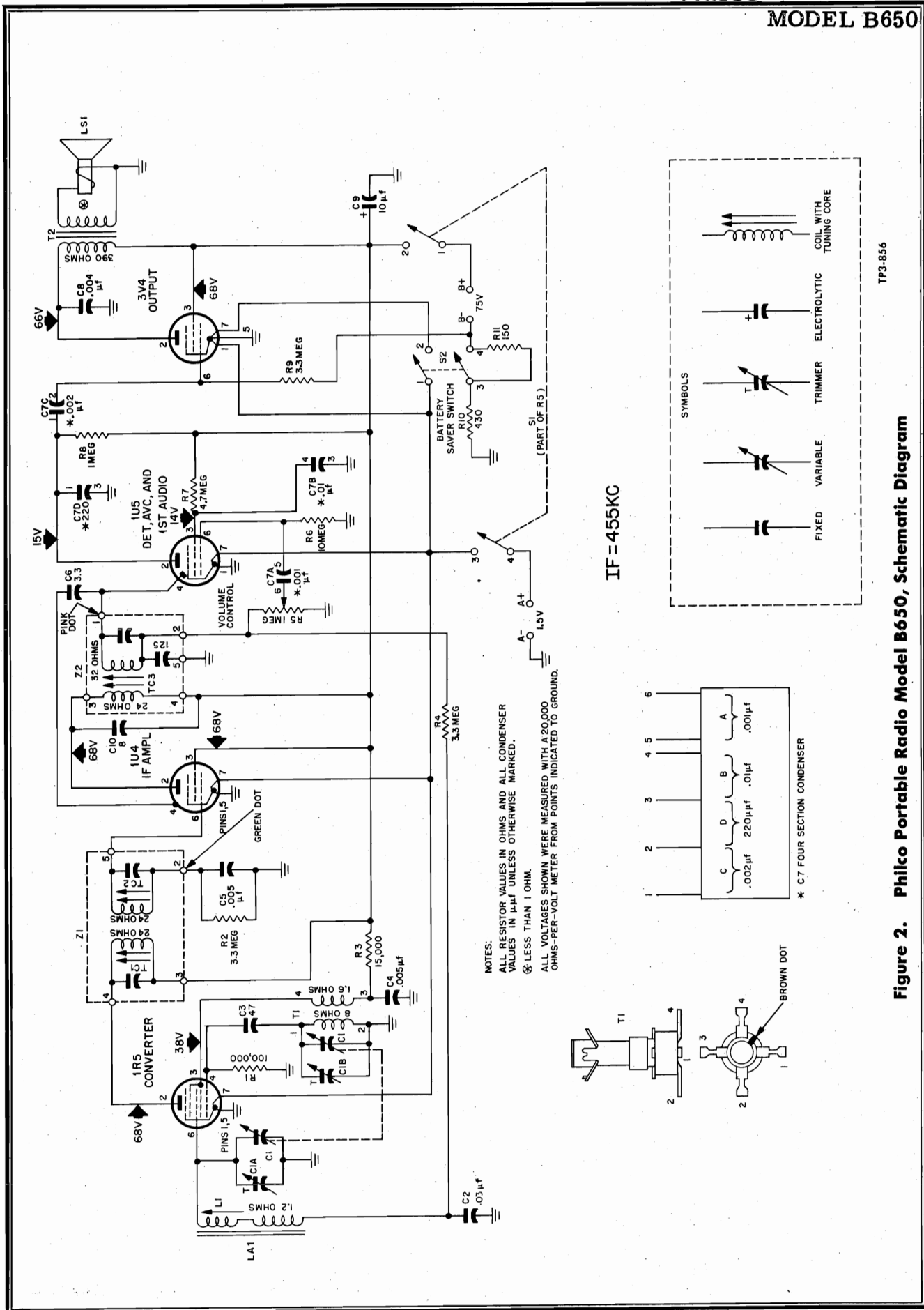

Figure 1. View Showing Tuning Adjustments and Parts Placement

TP3-836



TP3-856

Figure 2. Philco Portable Radio Model B650, Schematic Diagram

SPECIFICATIONS

CABINET		
B656	Molded plastic	
CIRCUIT	Five-tube superheterodyne (plus selenium rectifier)	
FREQUENCY RANGES		
Standard broadcast	550—1600 kc.	
Special services	1700—3400 kc.	
AUDIO OUTPUT	160 milliwatts	
OPERATING VOLTAGES	117 volts, a.c. or d.c.; or 9-volt	
	"A" battery and 90-volt "B" battery	
POWER CONSUMPTION		
A-c or d-c operation		15 watts
Battery operation	55 ma. at 9 volts, and 15 ma. at 90 volts	
AERIAL	Magnecor high-impedance loop; provision for connecting external aerial	
INTERMEDIATE FREQUENCY		265 kc.
PHILCO TUBES	1T4 r-f amplifier, 1R5 converter, 1U4 i-f amplifier, 1U5 det.—a.v.c.—1st audio 3V4 output	
BATTERY TYPE		Philco P-274

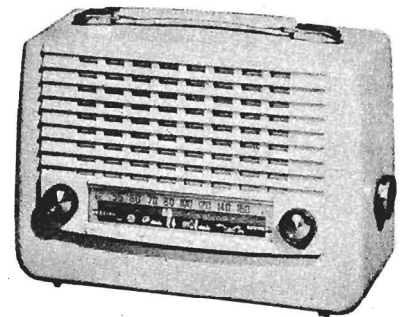

MODEL B656

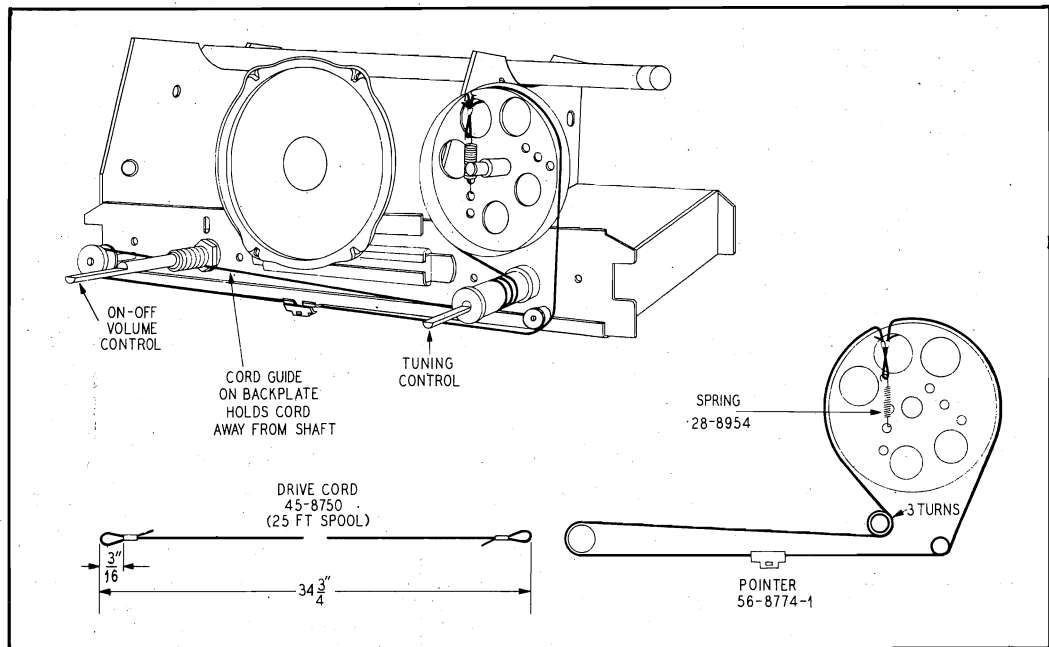

TP2-1392

Figure 1. Drive-Cord Installation Details

PR-2564

MODEL B656

ALIGNMENT PROCEDURE

POINTER—Set pointer to coincide with first index mark from left side of dial backplate (looking at front of dial backplate).

RADIO CONTROLS—Set volume control to maximum; set broadcast-special services switch, SW1, as indicated in chart.

OUTPUT METER—Connect across voice-coil terminals.

SIGNAL GENERATOR—Use modulated output.

OUTPUT LEVEL—During alignment, adjust signal-generator output to maintain output-meter indication below .5 volt.

CRITICAL LEAD DRESS—To secure proper padding capacity, the green lead from pin 6 of the 1R5 tube to Z1 must be dressed over the wiring panel, away from the chassis. The white lead which connects the low end of the aerial (LA1) to the broadcast-special services switch (SW1), must be dressed taut between the low-end tie lug and the retaining spring.

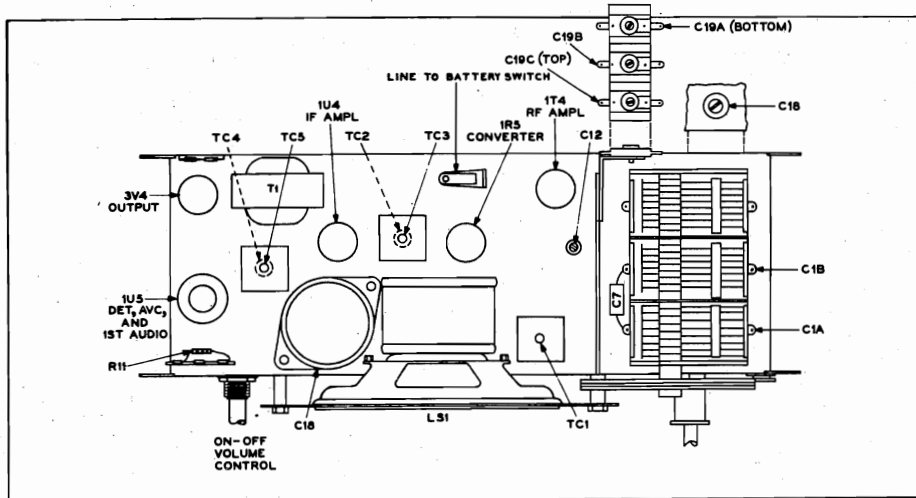

Figure 2. Top View, Showing Trimmer Locations

TP2-1394

STEP	SIGNAL GENERATOR		RADIO		ADJUST TRIMMER
	CONNECTION TO RADIO	DIAL SETTING	DIAL SETTING	SPECIAL INSTRUCTIONS	
1	Through a .1- μ f. condenser to pin 6 of 1R5 converter.	265 kc.	1630 kc. (gang fully open)	Set broadcast-special services switch to broadcast position. Adjust, in order given, for maximum output.	TC5—2nd i-f sec. TC4—2nd i-f pri. TC2—1st i-f pri. TC3—1st i-f sec.
2	Radiating loop. See note below.	1630 kc.	*1630 kc. (gang fully open)	Adjust for maximum output. If low-frequency dial tracking is far off, make adjustments in steps 3 and 4 before making this adjustment.	C1B—osc. shunt
3	Same as step 2.	580 kc.	580 kc.	Adjust for maximum output while rocking tuning control.	C12—osc. series
4	Same as step 2.	580 kc.	580 kc.	Adjust for maximum output. This adjustment should not be made unless dial tracking is off, or sensitivity is low at low-frequency end (580 kc.).	TC1—r-f sec.
5	Same as step 2.	1500 kc.	1500 kc. (index mark at right)	Adjust, in order given, for maximum output.	C1A—r-f C19A—BC aerial
6	Repeat steps 3 and 5 until no further improvement is obtained.				
7	Same as step 2.	3000 kc.	3000 kc.	Set broadcast-special services switch to special services position. Adjust, in order given, for maximum output.	C19C—SS aerial C18—r-f
8	Same as step 2.	1900 kc.	1900 kc.	Adjust, in order given, for maximum output.	C19B—SS aerial series tracker
9	Repeat steps 7 and 8, and then repeat step 5.				

NOTE: Make up a six-to-eight-turn, 6-inch diameter loop using insulated wire; connect to signal-generator leads and place near radio loop.

* For proper adjustment of the oscillator trimmer, fully open the tuning gang and insert a .006-inch, non-metallic shim between the heel of the rotor and the top of the stator plates. Close the tuning gang sufficiently to hold the shim in place, and then remove the shim without disturbing the gang setting.

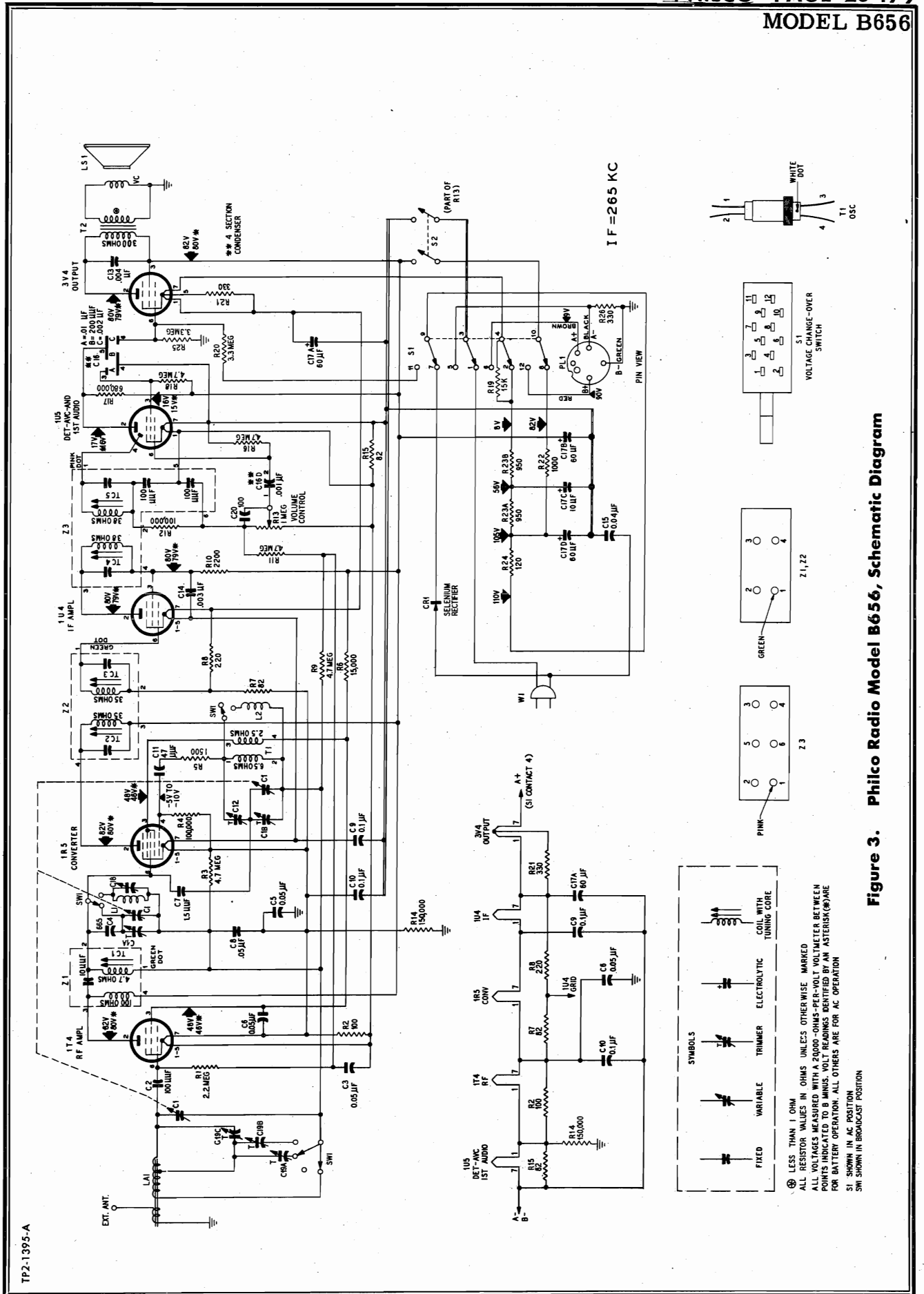

Figure 3. Philco Radio Model B656, Schematic Diagram

MODEL B656

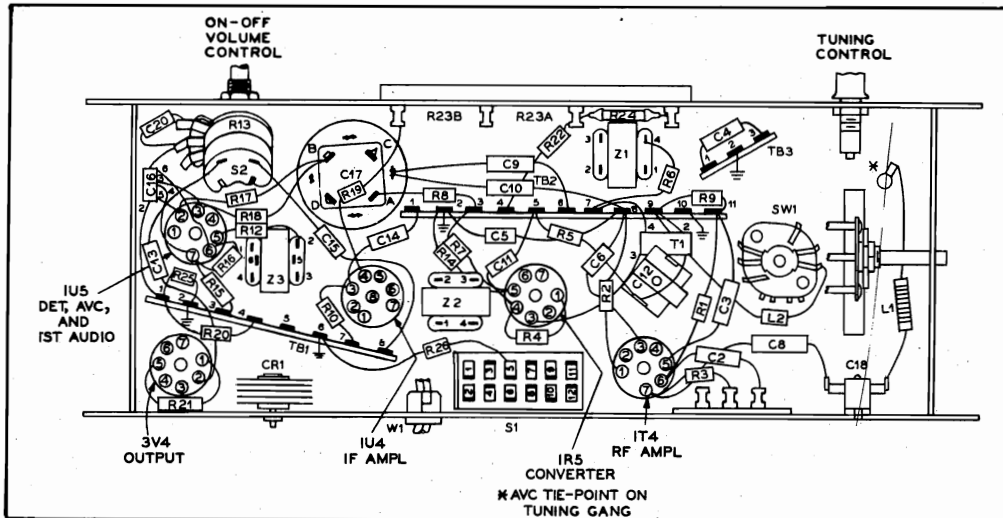

Figure 4. Bottom View, Showing Symbolized Chassis

TP2-1393-A

PARTS LIST

NOTE: Part numbers identified by an asterisk (*) are general replacement items. These numbers may not be identical with those on factory parts. Also, the electrical values of some replacement items may differ from the values indicated in the schematic diagram and parts list. The values substituted in any case are so chosen that the operation will be unchanged. When ordering replacements, use only the "Service Part No."

Reference Symbol	Description	Service Part No.	Reference Symbol	Description	Service Part No.
C1	Condenser, tuning gang, 3-section	31-2748-5	R18	Resistor, screen dropping, 4.7 megohms	66-5478340*
C1A	Condenser, r-f trimmer	Part of C1	R19	Resistor, filament, 15,000 ohms	66-3153546
C1B	Condenser, osc. trimmer	Part of C1	R20	Resistor, grid return, 3.3 megohms	66-5338340*
C2	Condenser, d-c blocking, 100 μ f.	62-110009001*	R21	Resistor, current limiting, 330 ohms	66-1338340*
C3	Condenser, bias filter, .05 μ f.	61-0122*	R22	Resistor, filter, 1000 ohms	66-2108340*
C4	Condenser, converter tracking, 665 μ f.	30-1220-66	R23	Resistor, wire-wound, 2-section	33-3431-7
C5	Condenser, filament by-pass, .05 μ f.	61-0122*	R23A	Resistor, filament dropping, 950 ohms	Part of R23
C6	Condenser, screen by-pass, .05 μ f.	61-0122*	R23B	Resistor, filament dropping, 950 ohms	Part of R23
C7	Condenser, neutralization, 1.5 μ f.	30-1221-3	R24	Resistor, wire-wound, current limiting, 120 ohms	33-1334-14
C8	Condenser, a-v-c filter, .05 μ f.	61-0122*	R25	Resistor, grid return, 3.3 megohms	66-5338340*
C9	Condenser, filament by-pass, .1 μ f.	61-0113*	R26	Resistor, bias resistor (battery operation), 330 ohms	66-1338340*
C10	Condenser, filament by-pass, .1 μ f.	61-0113*	S1	Switch, change-over	42-1899
C11	Condenser, d-c blocking, 47 μ f.	60-00475420	S2	Switch, on-off	Part of R13
C12	Condenser, osc. series padder, 700 to 900 μ f.	31-6473-28	SW1	Band switch	42-1986
C13	Condenser, tone compensation, .004 μ f.	61-0179	T1	Transformer, oscillator	32-4263-6
C14	Condenser, screen neutralizing, .003 μ f.	45-3505-61	T2	Transformer, output	32-8528
C15	Condenser, line by-pass, .04 μ f.	45-3500-2*	W1	Line cord	L2183
C16	Condenser, ceramic, 4-section	30-1237	Z1	Transformer, r-f	32-4399-6A
C16A	Condenser, screen by-pass, .01 μ f.	Part of C16	Z2	Transformer, 1st i-f	32-4160-2A
C16B	Condenser, by-pass, 200 μ f.	Part of C16	Z3	Transformer, 2nd i-f	32-4240-6A
C16C	Condenser, d-c blocking, .002 μ f.	Part of C16			
C16D	Condenser, d-c blocking, .001 μ f.	Part of C16			
C17	Condenser, electrolytic, 4-section	30-2568-58			
C17A	Condenser, filament by-pass, 60 μ f.	Part of C17			
C17B	Condenser, filter, 60 μ f.	Part of C17			
C17C	Condenser, filter, 10 μ f.	Part of C17			
C17D	Condenser, filter, 60 μ f.	Part of C17			
C18	Condenser, SS hi-frequency r-f trimmer	31-6476-27			
C19	Condenser, aerial trimmer, 3-section	31-6477-16			
C19A	Condenser, BC hi-frequency	Part of C19			
C19B	Condenser, SS low-frequency	Part of C19			
C19C	Condenser, SS hi-frequency	Part of C19			
C20	Condenser, compensating, high-frequency, 100 μ f.	62-110009001*			
CR1	Selenium rectifier	34-8003*			
L2	Coil, oscillator shunt	32-4562			
LA1	Coil, aerial	32-4565			
LS1	Speaker, 5-inch	36-1625			
PL1	Plug-and-cable assembly, battery	41-3712-5			
R1	Resistor, grid return, 2.2 megohms	66-5228340*			
R2	Resistor, current limiting, 100 ohms	66-1108340*			
R3	Resistor, grid return, 4.7 megohms	66-5478340*			
R4	Resistor, grid return, 100,000 ohms	66-4108340*			
R5	Resistor, oscillator coupling, 1500 ohms	66-2158340*			
R6	Resistor, dropping, 15,000 ohms	66-3158340*			
R7	Resistor, grid return, 82 ohms	66-0828340*			
R8	Resistor, grid return, 220 ohms	66-1228340*			
R9	Resistor, a-v-c filter, 4.7 megohms	66-5478340*			
R10	Resistor, neutralization, 2200 ohms	66-2228340*			
R11	Resistor, a-v-c filter, 4.7 megohms	66-5478340*			
R12	Resistor, i-f filter, 100,000 ohms	66-4108340*			
R13	Resistor, volume control, 1 megohm	45-5001-21			
R14	Resistor, leakage, 150,000 ohms	66-4158340*			
R15	Resistor, current limiting, 82 ohms	66-0828340*			
R16	Resistor, grid return, 4.7 megohms	66-5478340*			
R17	Resistor, plate load, 680,000 ohms	66-4688340*			

MISCELLANEOUS

Description	Service Part No.
Cabinet, light beige	10883-4
Back, light beige	54-4903
Clip, back (2)	56-3807-3
Handle assembly	76-7719-2
Scale, light beige	54-5148
Knob (2)	54-4773-1
Knob (1)	54-4816-4
Cabinet, pine green	10883-5
Back, pine green	54-4903-2
Clip, back (2)	56-3807-3
Handle assembly	76-7719-2
Scale, pine green	54-5148
Knob (2)	54-4773-5
Knob (1)	76-6206-1
Cabinet, charcoal gray	10883-6
Back, charcoal gray	54-4903-3
Clip, back (2)	56-3807-3
Handle assembly	76-7719-2
Scale, charcoal gray	54-5148-1
Knob (2)	54-4773-6
Knob (1)	54-4816-6
Dial-backplate assembly	76-7720
Drive cord, 25-ft. spool	45-8750*
Pointer	56-8774-1
Spring, drive cord	28-8954
Shaft-and-pulley assembly	76-7687
Mount, rubber (3)	27-4596
Spring, retaining	57-1868FA11
Shield, 1U5 tube	56-5629FA3
Socket (3)	27-6203
Socket, 1U5 tube (1)	27-6203-22
Socket, 3V4 tube (1)	27-6203-12

ALIGNMENT PROCEDURE

GENERAL

RADIO CONTROLS—Set volume control for maximum output and tuning control as given in the alignment chart. Set band switch to broadcast position for first 5 steps, and to special services position for steps 6 and 7.

OUTPUT INDICATOR—Connect output indicator (either on oscilloscope or a 1000-ohms-per-volt, a-c voltmeter) across voice-coil terminals.

SIGNAL GENERATOR—Use an AM r-f generator, connected as indicated in the alignment chart.

OUTPUT LEVEL—During alignment, attenuate signal-generator output to maintain output indication below 1 volt.

DIAL POINTER—Before the alignment is started, the dial pointer should be set to coincide with the dial scale mark to the left of "55" when the tuning gang is fully meshed.

ALIGNMENT CHART

STEP	SIGNAL GENERATOR		RADIO		ADJUST
	CONNECTION TO RADIO	DIAL SETTING	DIAL SETTING	SPECIAL INSTRUCTIONS	
1	Ground lead to B— Output lead through a .01- μ f. condenser to pin 7 (mixer grid) of 12BE6, converter.	455 kc.	Tuning gang fully open.	Adjust in order given in next column, for maximum output.	TC5—2nd i-f sec. TC4—2nd i-f pri. TC3—1st i-f sec. TC2—1st i-f pri.
2	Radiating loop. See note 1 below.	1620 kc.	1620 kc. See note 2 below.	Adjust for maximum output.	CI C—osc. trimmer
3	Same as step 2.	1520 kc.	Tune radio to generator signal.	Adjust for maximum output. (High-frequency adjustment)	CI B—mixer-grid trimmer CI A—r-f trimmer
4	Same as step 2.	580 kc.	Same as step 3.	Adjust for maximum output. (Low-frequency adjustment)	TC I—r-f transformer
5	Repeat steps 3 and 4 until no further improvement is obtained.				
6	Same as step 2.	3200 kc.	Same as step 3.	Adjust for maximum output.	C5—special-services mixer-grid trimmer C2—special-services r-f trimmer
7	Same as step 2.	1800 kc.	Same as step 3.	Adjust for maximum output.	C3—special-services r-f padder

NOTE 1: Make up a 6—8 turn, 6-inch-diameter loop from insulated wire; connect to signal-generator leads and place near radio loop antenna. The loop antenna must be connected to the radio.

NOTE 2: To set the tuning gang to 1620 kc., place a piece of 6-mil flat shim stock beneath the heel of the rotor, and turn the rotor until it holds the shim firmly in place. Then remove the shim.

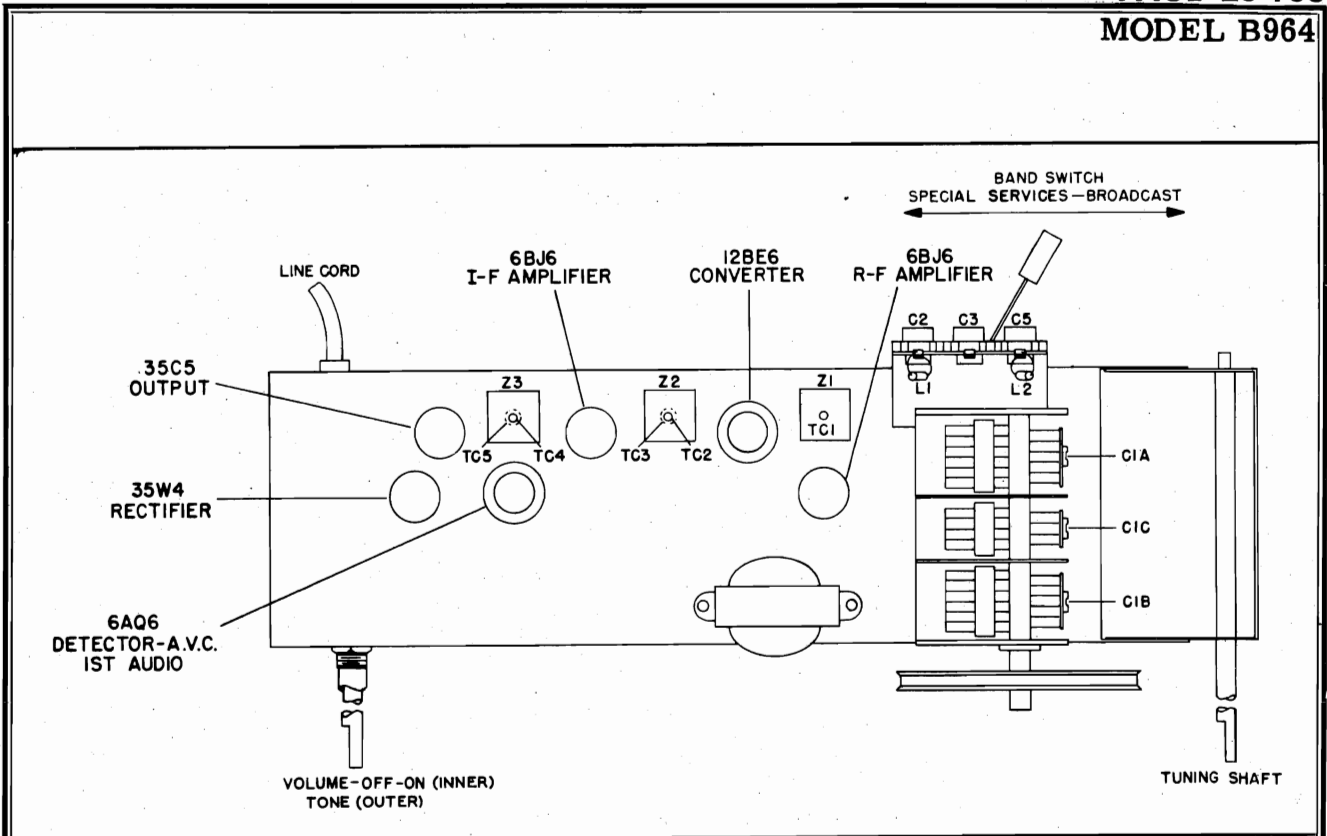

TP3-878

Figure 2. Top View, Showing Tuning Adjustments

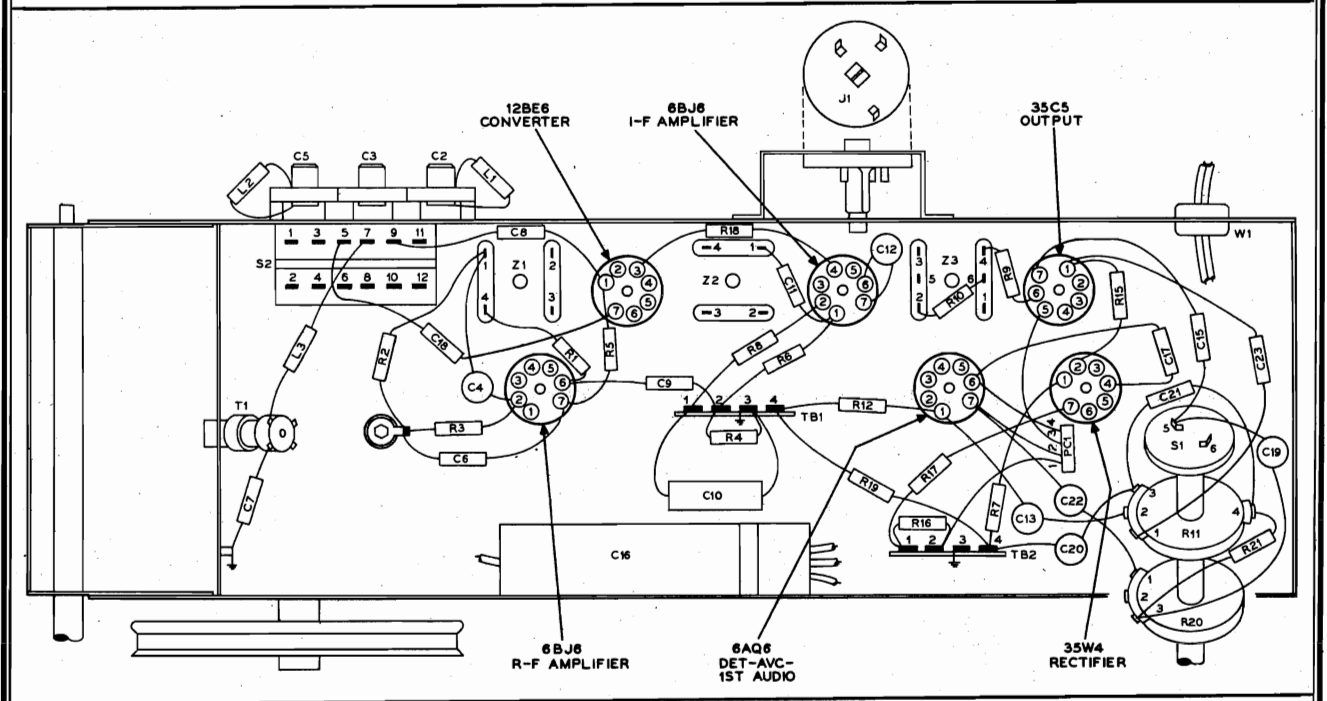

TP3-879

Figure 3. Base View, Showing Parts Placement

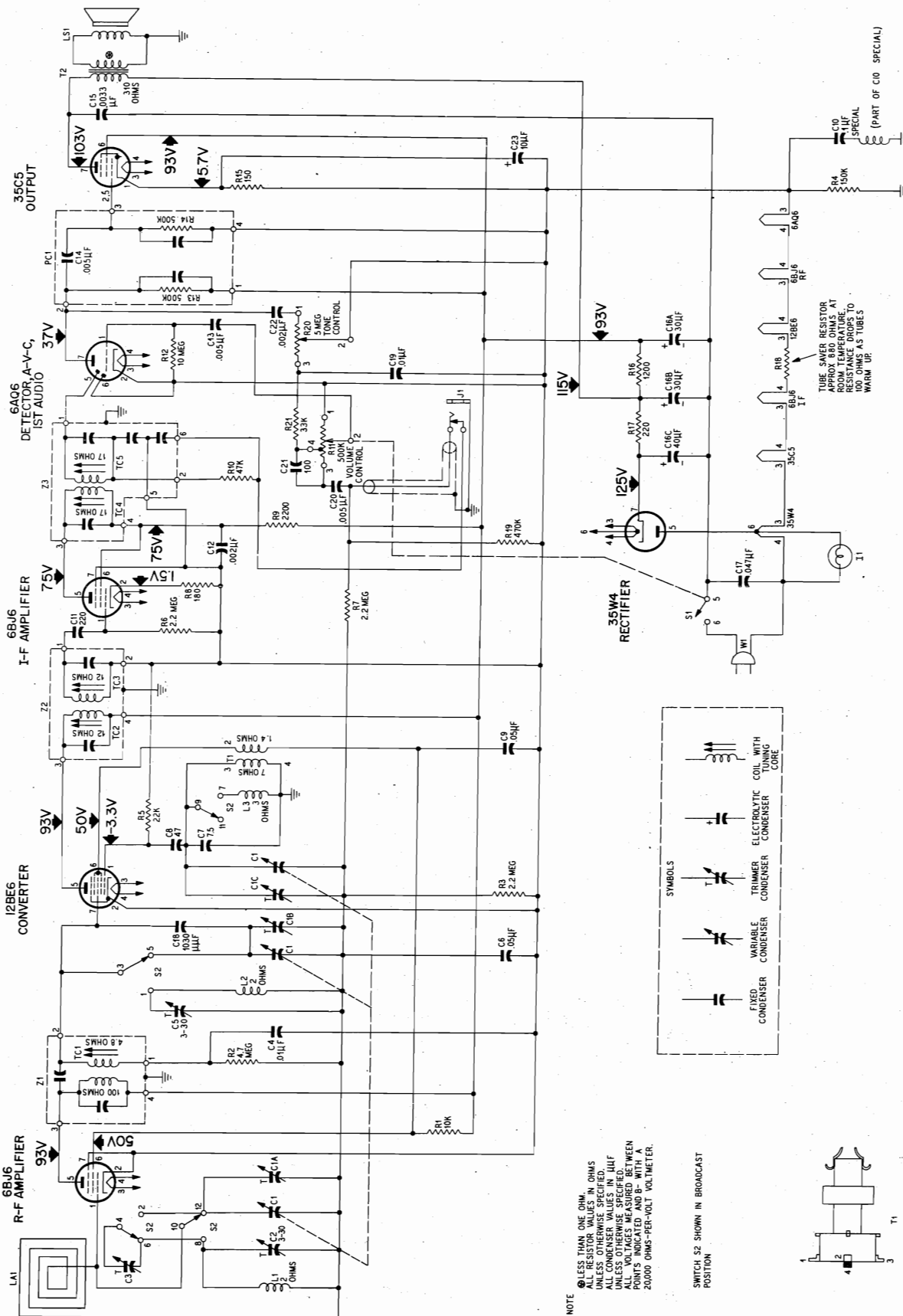

NOTE
 @ LESS THAN ONE OHM
 ALL RESISTOR VALUES IN OHMS
 UNLESS OTHERWISE SPECIFIED.
 ALL CAPACITOR VALUES IN μF
 UNLESS OTHERWISE SPECIFIED.
 ALL VOLTAGES MEASURED BETWEEN
 POINTS INDICATED AND B- WITH A
 20,000 OHMS-PER-VOLT VOLTMETER.

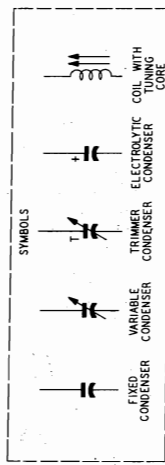

SWITCH S2 SHOWN IN BROADCAST POSITION

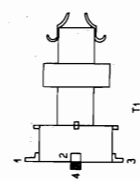

TUBE Saver RESISTOR APPROX 180 OHMS AT 100 OHMS AS TUBES WARM UP. RESISTANCE DROPS TO 100 OHMS AS TUBES WARM UP.

Figure 4. Philco Radio Model B964, Schematic Diagram

PARTS LIST

NOTE: Part numbers identified by an asterisk (*) are general replacement items. These numbers may not be identical with those on factory parts. Also, the electrical values of some replacement items may differ from the values indicated in the schematic diagram and parts list. The values substituted in any case are so chosen that the operation will be unchanged. When ordering replacements, use only the "Service Part No."

Reference Symbol	Description	Service Part No.	Reference Symbol	Description	Service Part No.
C1	Condenser, tuning gang, 3 section	31-2771-1	R13	Resistor, plate load, 500,000 ohms	Part of PC1
C1A	Condenser, trimmer, antenna	Part of C1	R14	Resistor, grid leak, 500,000 ohms	Part of PC1
C1B	Condenser, trimmer, r-f	Part of C1	R15	Resistor, cathode bias, 150 ohms, 1 watt	66-115434*
C1C	Condenser, trimmer, oscillator	Part of C1	R16	Resistor, B+ filter, 1200 ohms	66-2128340*
C2	Condenser, trimmer, special services r-f	Part of CA1	R17	Resistor, B+ filter, 220 ohms, 1 watt	66-1224340*
C3	Condenser, padder, special services r-f	Part of CA1	R18	Resistor, tube saver, 100 ohms	33-1343-3
C4	Condenser, r-f by-pass, .01 μ f.	30-1238-2*	R19	Resistor, diode load, 470,000 ohms	66-4478340
C5	Condenser, trimmer, special services mixer-grid	Part of CA1	R20	Resistor, tone control, 5 megohms	Part of R11
C6	Condenser, a-v-c by-pass .05 μ f.	30-4650-45*	R21	Resistor, tone compensation, 33,000 ohms	66-3338340
C7	Condenser, fixed trimmer, 7.5 μ f.	30-1224-65	S1	Switch, off-on	Part of R11
C8	Condenser, d-c blocking, 47 μ f.	60-00475420	S2	Switch, broadcast-special services	42-1893-5
C9	Condenser, screen by-pass, .05 μ f.	30-4650-45*	T1	Transformer, oscillator	32-4453-2
C10	Condenser, special, B- to chassis, .1 μ f.	30-4644-3	T2	Transformer, output	32-8310-9
C11	Condenser, i-f coupling, 220 μ f.	62-122001001*	W1	Line cord	L-2183*
C12	Condenser, screen by-pass, .002 μ f.	30-1238-8*	Z1	Transformer, r-f	32-4399-7A
C13	Condenser, audio coupling, .005 μ f.	30-1238-1*	Z2	Transformer, 1st i-f	32-4160A
C14	Condenser, d-c blocking, .005 μ f.	Part of PC1	Z3	Transformer, 2nd i-f	32-4240A
C15	Condenser, tone compensation, .0033 μ f.	30-4650-55			
C16	Condenser, electrolytic filter	45-3037-3			
C16A	Condenser, filter, 30 μ f., 150v	Part of C16			
C16B	Condenser, filter, 30 μ f., 150v	Part of C16			
C16C	Condenser, filter, 40 μ f., 150v	Part of C16			
C17	Condenser, line by-pass, .047 μ f.	30-4650-45*			
C18	Condenser, fixed padder, 1030 μ f.	30-1220-72			
C19	Condenser, bass comp., .01 μ f.	30-1238-2			
C20	Condenser, phono coupling, .005 μ f.	30-1238-1			
C21	Condenser, high comp., 100 μ f.	62-110009001			
C22	Condenser, tone comp., .002 μ f.	30-1238-8			
C23	Condenser, cathode by-pass, 10 μ f., 50v	45-3035-6			
CA1	Condenser assembly, trimmer	31-6477-17			
II	Lamp, pilot	34-2068			
L1	Coil, special services r-f	32-4561-5			
L2	Coil, special services mixer-grid	32-4561-5			
L3	Coil, oscillator shunt	32-4562-1			
PC1	Printed circuit	30-6001			
R1	Resistor, screen dropping, 10,000 ohms	66-3108340*			
R2	Resistor, a-v-c load, 4.7 megohms	66-5478340*			
R3	Resistor, a-v-c load, 2.2 megohms	66-5228340*			
R4	Resistor, B- to chassis, 150,000 ohms	66-4158340*			
R5	Resistor, grid leak, 22,000 ohms	66-3228340*			
R6	Resistor, grid leak, 2.2 megohms	66-5228340*			
R7	Resistor, a-v-c load, 2.2 megohms	66-5228340*			
R8	Resistor, cathode bias, 180 ohms	66-1188340*			
R9	Resistor, screen dropping, 2200 ohms	66-2228340*			
R10	Resistor, i-f filter, 47,000 ohms	66-3478340*			
R11	Volume control, 500,000 ohms	33-5563-64			
R12	Resistor, grid leak, 10 megohms	66-6108340*			

MISCELLANEOUS

PARTS COMMON TO ALL MODELS

Description	Service Part No.
Drive cord, 25-ft. spool	45-8750*
Spring, drive cord	56-2617
Rubber mount, gang mtg. (3)	27-4596
Shield, tube (2)	56-5629FA3
Socket assembly, pilot lamp	27-6233-6
Socket, tube (2)	27-6203-14
Socket, tube (4)	27-6265
Speed nut (4)	1W56920FE7
Cabinet	10963
Cabinet back and loop assembly	76-8068
Knob, band switch	54-4998
Knob, off-on-volume	54-4842-7
Knob, tone	76-6353-1
Knob, tuning	76-6354-1
Panel, diffusing	54-8819
Clip, panel diffusing	56-3587-1
Pointer	56-5630-51
Pointer rail assembly	76-8067
Scale, dial	54-5163
Shaft, tuning	56-9807-6
Spring, retaining	28-8610
Speaker	36-1641-12

MODEL B651

SPECIFICATIONS

MODEL B651

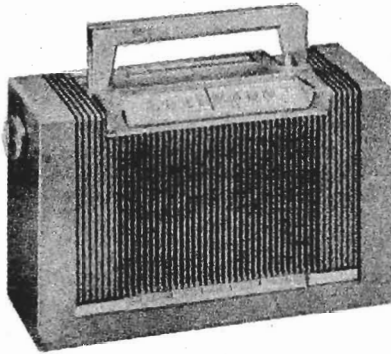

MODEL B651

CABINET	Molded plastic
CIRCUIT	Four-tube superheterodyne (plus selenium rectifier)
FREQUENCY RANGE	540 kc.—1620 kc.
AUDIO OUTPUT	
A.C. or d.c.	150 milliwatts
Battery	75 milliwatts
OPERATING VOLTAGE	
Line operation	117 volts, a.c. or d.c.
Battery operation	2 D cells and 67½-volt "B" battery
POWER CONSUMPTION	
A-C or d-c operation	15 watts
Battery operation	10 ma. from 67½-volt "B" battery; 260 ma. from 2 D cells
ANTENNA	Magnecor high-impedance loop with provision for external antenna
INTERMEDIATE FREQUENCY	455 kc.
PHILCO TUBES	1R5, converter; 1U4, i-f amplifier; 1U5, detector-a.v.c.-1st audio; 3V4, output
BATTERY TYPE	P67 "B" battery; 2 D cells

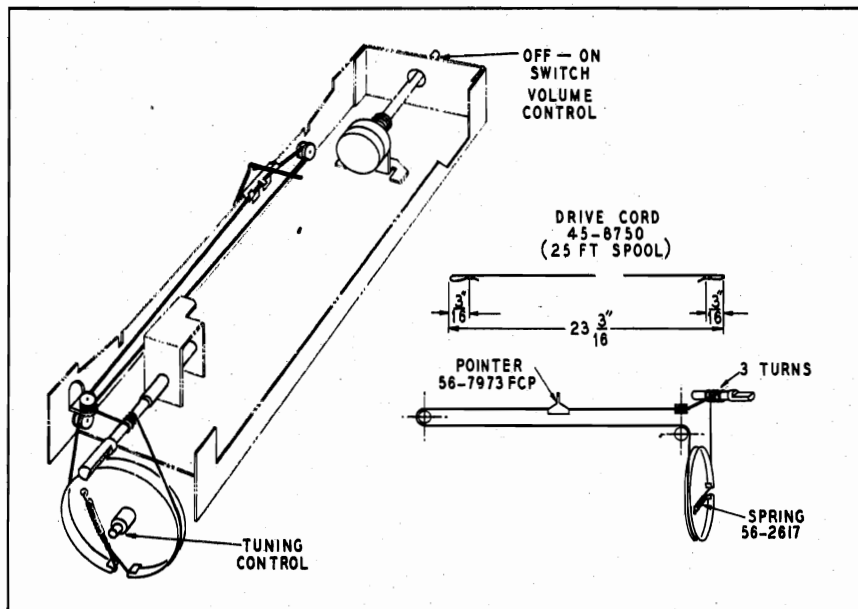
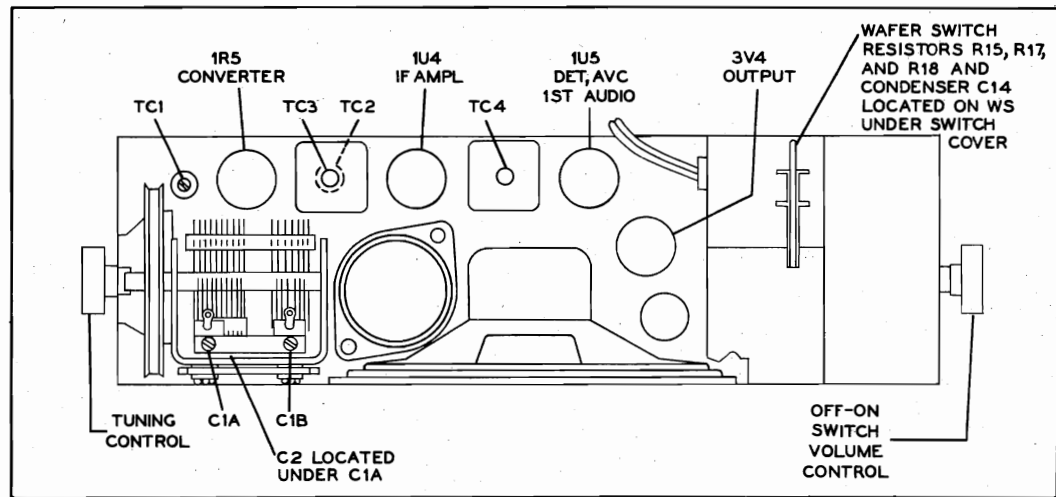

Figure 1. Drive-Cord Stringing Arrangement

TP0-390

PR-2537



TP0-392

Figure 2. Top View, Showing Tuning Adjustments

ALIGNMENT PROCEDURE

DIAL POINTER—With tuning-condenser plates fully meshed, set pointer to coincide with alignment index mark on bottom of chassis.

OUTPUT INDICATOR—Connect output indicator (oscilloscope or 1000-ohms-per-volt a-c voltmeter) across voice-coil terminals.

SIGNAL GENERATOR—Use AM r-f signal generator. Connect output leads as indicated in alignment chart.

RADIO CONTROLS—Set volume control to maximum. Set tuning control as indicated in chart.

OUTPUT LEVEL—During alignment, attenuate

signal-generator output to maintain output level below .5 volt.

NOTE: While the radio is being aligned, the batteries should be in the same position with respect to chassis and loop as they are when in the cabinet.

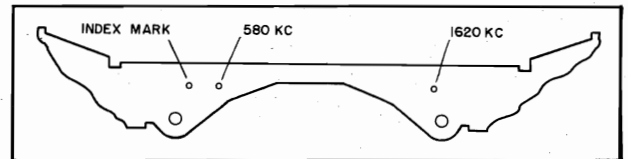

TP3-124

Figure 3. Front View of Pointer Rail, Showing Alignment Marks

ALIGNMENT CHART

STEP	SIGNAL GENERATOR		RADIO		ADJUST
	CONNECTION TO RADIO	DIAL SETTING	DIAL SETTING	SPECIAL INSTRUCTIONS	
1	Output lead through a .1- μ f. condenser to antenna section of tuning condenser or to pin 6 of converter (1R5). Ground lead to B-.	455 kc.	Tuning gang fully open.	Adjust, in order given for maximum output.	TC4—2nd i-f sec. TC2—1st i-f pri. TC3—1st i-f sec.
2	Radiating loop. See NOTE below.	1620 kc.	1620 kc.†	Adjust for maximum output.	C1B—osc. trimmer
3	Same as step 2.	Between 1400 and 1500 kc.	Tune radio to generator signal.	Adjust for maximum output.	C1A—antenna trimmer
4	Same as step 2.	580 kc.	580 kc.†	Adjust for maximum output. Rock tuning gang while making this adjustment.	TC1—osc. core
5	Repeat steps 2, 3, and 4 until no further improvement is obtained.				

NOTE: Use a 6–8 turn, 6-inch diameter loop made up of insulated wire. Connect to signal-generator leads, and place about 1 foot from radio loop antenna.

† The radio can be set to this frequency by tuning it until the dial pointer coincides with the proper alignment mark on the bottom of the chassis. See figure 3.

MODEL B651

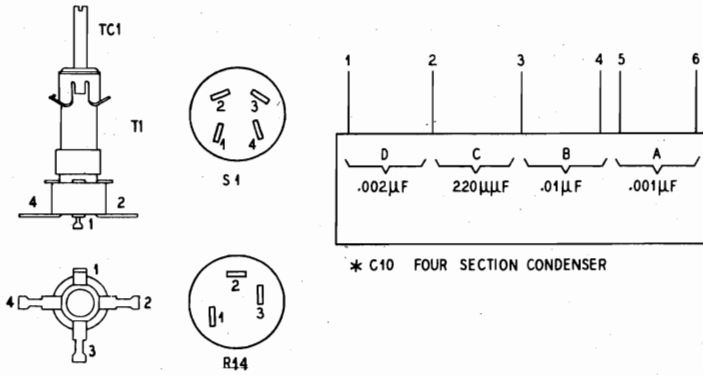

TUBE SOCKET VOLTAGES

B SUPPLY	1R5		1U4		1U5		3V4	
	R F PLATE PIN 2	OSC PLATE PIN 3	PLATE PIN 2	SCREEN PIN 3	PLATE PIN 2	SCREEN PIN 3	PLATE PIN 2	SCREEN PIN 3
PWR LINE (AC OR DC)	90	55	90	90	18	16	86	90
67½V BATTERY	65	38	65	65	17	16	62	65

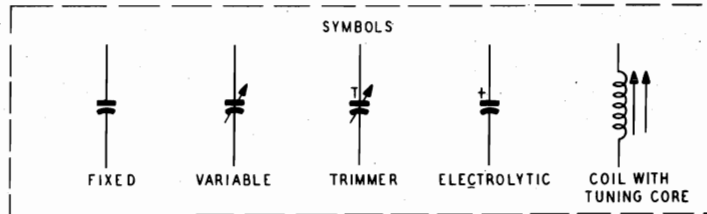

NOTES:
 ALL RESISTOR VALUES IN OHMS AND ALL CONDENSER VALUES IN µUF UNLESS OTHERWISE MARKED.
 ⊕ LESS THAN 1 OHM
 ALL VOLTAGES SHOWN WERE MEASURED WITH A 20,000-OHMS-PER-VOLT METER FROM POINTS INDICATED TO B-.

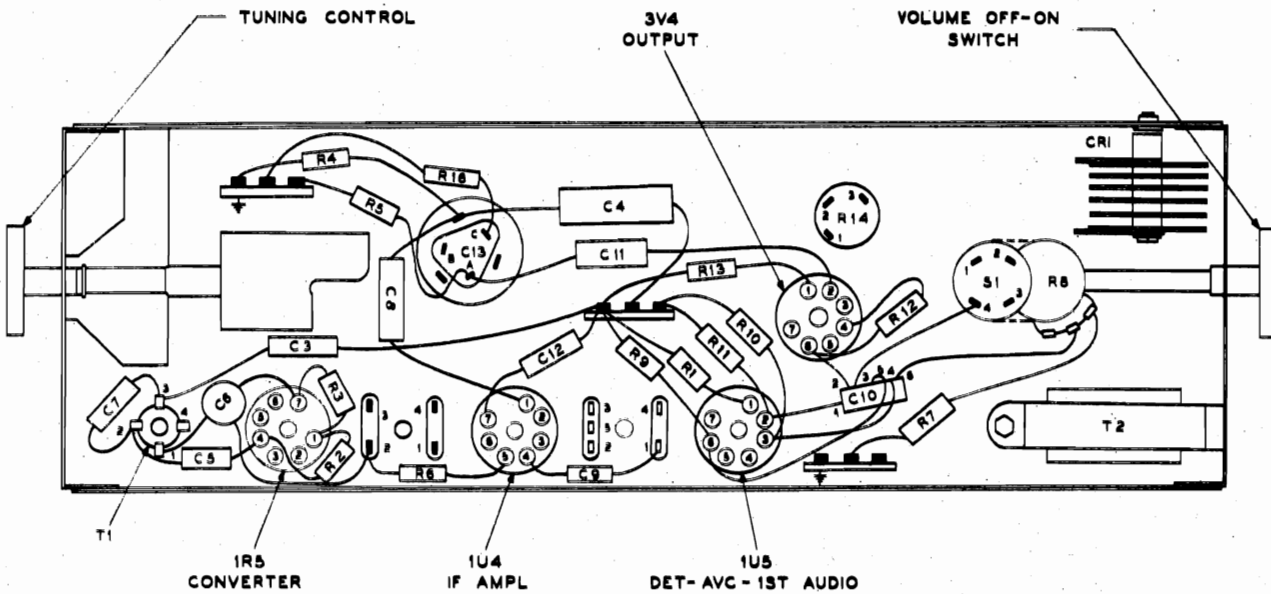

Figure 5. Base View, Showing Parts Placement

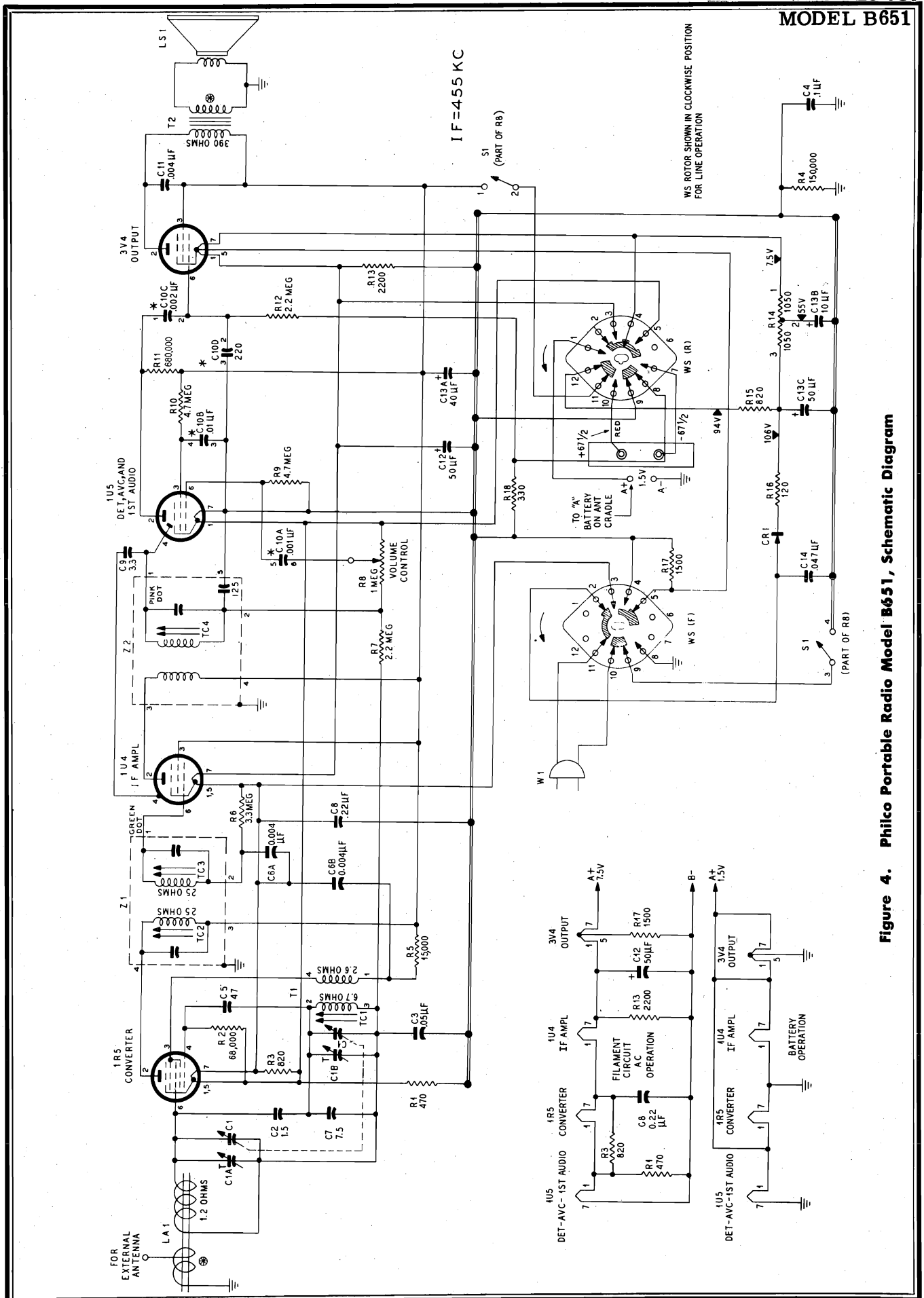

Figure 4. Philco Portable Radio Model B651, Schematic Diagram

MODEL B651

PARTS LIST

NOTE: Part numbers identified by an asterisk (*) are general replacement items. These numbers may not be identical with those on factory parts; also, the electrical values of some replacement items may differ from the values indicated in the schematic diagram and parts list. The values substituted in any case are so chosen that the operation of the radio will be unchanged. When ordering replacements, use only the "Service Part No."

Reference Symbol	Description	Service Part No.	Reference Symbol	Description	Service Part No.
C1	Condenser, tuning gang, 2-section	31-2735-2	R13	Resistor, bias, 2200 ohms	66-2228340*
C1A	Condenser, trimmer, antenna	Part of C1	R14	Resistor, filament dropping and filter, 2100 ohms (center-tapped)	33-3445
C1B	Condenser, trimmer, oscillator	Part of C1	R15	Resistor, filter, 820 ohms	66-1828340*
C2	Condenser, neutralizing, 1.5 μ f.	30-1221-3	R16	Resistor, current limiting, 120 ohms	33-1334-14
C3	Condenser, a-v-c by-pass, .05 μ f.	30-4650-45*	R17	Resistor, bias, 1500 ohms	66-2158340*
C4	Condenser, B- to ground, .1 μ f.	30-4650-47*	R18	Resistor, bias, 330 ohms	66-1338340*
C5	Condenser, d-c blocking, 47 μ f.	60-00475420	S1	Switch, off-on	Part of R8
C6	Condenser, dual ceramic	30-1239	T1	Transformer, oscillator	32-4453-1
C6A	Condenser, osc. B+ by-pass, .004 μ f.	Part of C6	T2	Transformer, output	32-8434
C6B	Condenser, grid by-pass, .004 μ f.	Part of C6	W1	Line cord	L2183
C7	Condenser, temperature compensation, 7.5 μ f.	30-1224-83	WS	Wafer switch, voltage change-over	42-1925
C8	Condenser, filament by-pass, .25 μ f.	30-4656-1	Z1	Transformer, 1st i-f	32-4160-4A
C9	Condenser, neutralizing, 3.3 μ f.	30-1221	Z2	Transformer, 2nd i-f	32-4454-1A
C10	Condenser, ceramic, 4-section	30-1237	MISCELLANEOUS		
C10A	Condenser, d-c blocking, .001 μ f.	Part of C10	Description		Service Part No.
C10B	Condenser, screen by-pass, .01 μ f.	Part of C10	Cabinet, sand	10799-28	
C10C	Condenser, d-c blocking, .002 μ f.	Part of C10	Back, cabinet, sand	54-4767-25	
C10D	Condenser, grid by-pass, 220 μ f.	Part of C10	Cabinet, driftwood	10799-26	
C11	Condenser, tone compensation, .004 μ f.	30-4650-56*	Back, cabinet, driftwood	54-4767-23	
C12	Condenser, electrolytic, filament by-pass, 50 μ f., 25v	30-2417-12	Cabinet, spruce green	10799-25	
C13	Condenser, electrolytic, 3-section	30-2568-39	Back, cabinet, spruce green	54-4767-22	
C13A	Condenser, filter, 40 μ f., 150v	Part of C13	Cable, battery	41-3988	
C13B	Condenser, filter, 10 μ f., 150v	Part of C13	Cover, sub-base	56-7912	
C13C	Condenser, filter, 50 μ f., 150v	Part of C13	Cover, switch	56-7911	
C14	Condenser, line by-pass, .047 μ f.	30-4650-45*	Dial scale	54-5087	
CR1	Selenium rectifier, 75 ma. at 117 volts	34-8003	Drive cord (25-ft. spool)	45-8750*	
LA1	Loop antenna	32-4455-10	Fastener, baffle mtg. (4 required)	W2235-7FA9	
LS1	Speaker, 4-inch, p-m	36-1637	Handle	54-4883	
R1	Resistor, current limiting, 470 ohms	66-1478340*	Hinge, R.H.	56-7915-1	
R2	Resistor, grid return, 68,000 ohms	66-3688340*	Hinge, L.H.	56-7915	
R3	Resistor, bias, 820 ohms	66-1828340*	Insulator, capacitor mtg.	27-9508	
R4	Resistor, leakage, 150,000 ohms	66-4158340*	Knob (2 required)	54-4773	
R5	Resistor, oscillator dropping, 15,000 ohms	66-3158340*	Nameplate	54-4884	
R6	Resistor, grid return, 3.3 megohms	66-5338340*	Pointer	56-7973-1	
R7	Resistor, a-v-c filter, 2.2 megohms	66-5228340*	Ring, shaft retaining	28-8610	
R8	Resistor, VOLUME control (with "off-on" switch), 1 megohm	33-5566-21	Rubber mount, tuning capacitor (3 required)	27-4099-3	
R9	Resistor, grid return, 4.7 megohms	66-5478340*	Screw, hinge (2 required)	W2537-15FA1	
R10	Resistor, screen dropping, 4.7 megohms	66-5478340*	Speed nuts, nameplate mtg. (2 required)	1W56912FE7	
R11	Resistor, plate load, 680,000 ohms	66-4688340*	Shaft, tuning	56-7906FA42	
R12	Resistor, grid return, 2.2 megohms	66-5228340*	Shield, tube (1U5)	56-3978-1FA3	
			Socket	27-6203	
			Socket	27-6203-12	
			Battery cradle and antenna ass'y.	76-5740-1	

Specifications

Tuning Range	540-1,600 kc
Intermediate Frequency	455 kc
Power Supply Rating	
Power Line Operation	
115 volts, d. c. or 50 to 60 cycles a. c.	15 watts or
Battery Operated	using RCA VS 057 Battery
(Average battery life — 100 hrs. intermittent service)	
Battery current	"A" 50 ma., "B" 13 ma.
Tube Complement	
(1) RCA 1T4	R.F. Amplifier
(2) RCA 1R5	Converter
(3) RCA 1T4	I.F.-Amplifier
(4) RCA 1U5	Det. — AVC — 1st A.F.
(5) RCA 3V4	Output

A selenium rectifier is used.

Weight (Approx.)
 Without battery... 5 lb. 10 oz. With battery... 9 lb. 6 oz.

Power Output
 Undistorted
 .150 watt || Maximum | .325 watt |

Loudspeaker
 4 in. P.M. || Voice coil impedance | 3.2 ohms at 400 cycles |

Cabinet Dimensions
 Height..... 8 5/8 in. Width..... 12 3/4 in. Depth..... 5 5/8 in.



To Remove Hinges

Remove back from cabinet as described at right. Spread the hinge apart to remove it from the cabinet back.

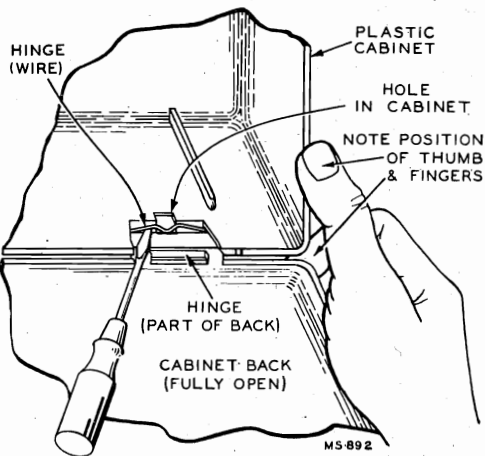

Removal of Cabinet Back

To Remove Chassis:

1. Pull out battery and disconnect battery plug.
2. Unsolder the two loop antenna leads.
3. Remove handle, remove the two large screws (under handle) in the top of the case.

To Remove Cabinet Back

With the back fully open, grip the cabinet as illustrated. Insert a screwdriver under one hinge and pry the center of the hinge out of the opening in the cabinet while maintaining pressure on the back with the fingers and on the cabinet with the thumb. Repeat this procedure with the other hinge. Pull the back straight to the rear using both hands.

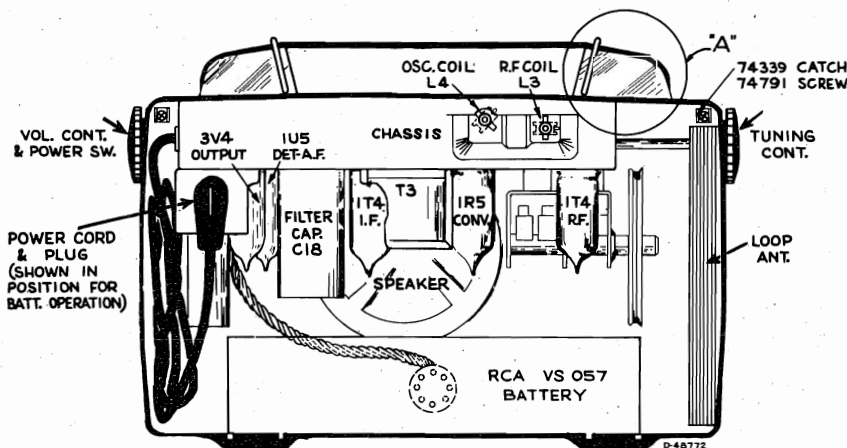
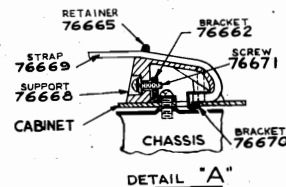

Rear View With Back Removed

MODEL PX600, Ch. RC-1110

Alignment Procedure

Output Meter Alignment—If this method is used, connect the meter across the voice coil and turn the receiver volume control to maximum.

Test Oscillator—For all alignment operations, connect the low side of the test oscillator to the receiver chassis and keep the oscillator output as low as possible to avoid AVC action.

Battery operation of the receiver is preferable during alignment; on AC operation an isolation transformer (117v./117v.) may be necessary for the receiver if the test oscillator is also AC operated.

Dial Pointer Position—With the tuning condenser fully meshed the center of the dial pointer should be in line with the score mark on the chassis.

Step	Connect High Side of Sig. Gen. to —	Sig. Gen. Output	Dial Pointer Setting	Adjust for Max. Output
1	Disconnect loop—remove chassis—remove bottom plate.			
2	Pin #6 of 1T4 I.F. Amplifier thru .005 mf.	455 kc	Quiet point near 1600 kc	2nd I.F. Trans. T2 Top & Bottom
3	Pin #6 of 1R5 Converter thru .005 mf.			1st I.F. Trans. T1 Top & Bottom
4	Replace bottom cover and install chassis in cabinet. Re-connect loop.			
5		1620 kc	min. cap.	1600 kc osc. trimmer C1-3T
6		1400 kc	1400 kc Signal	1400 kc r.f. & ant. trimmers*
7	Short wire placed near loop for radiated signal	Connect a 22,000 ohm resistor in parallel with r.f. tuning cond. C1-2		
8		600 kc	600 kc Signal	L4 osc. core* while rocking gang
9		Remove the 22,000 ohm resistor from r.f. tuning cond. C1-2.		
10		600 kc	600 kc Signal	L3 r.f. core
11	Repeat Steps 5, 6, 7, 8, 9 and 10.			

* The position of the battery affects loop inductance. The battery should be in place during steps 5 to 11.

Critical Lead Dress

1. Dress all filament leads next to chassis.
2. Keep the leads short on the end of the three components (R1, R2, C2), which connect to the grid terminal (#6) of the r.f. socket.
3. Dress tuning condenser leads direct and avoid excess lead length.
4. Dress loop leads away from tuning drum and battery.
5. Dress r.f. plate lead against chassis base.
6. Dress a.v.c. lead against chassis base.
7. Dress +B lead to output transformer against chassis base.
8. Dress 1st a.f. plate resistor (R15) up and away from other wiring.
9. Dress all leads away from the ballast resistor. (R19).
10. Dress 1st a.f. grid resistor (R12) close to chassis.
11. Dress capacitor C3 in air between end apron and r.f. coil with foil end to tuning condenser frame.

CAUTION.—

Do not remove any tubes from the chassis with the set operating and the plug connected to the power line. Damage to tubes may result.

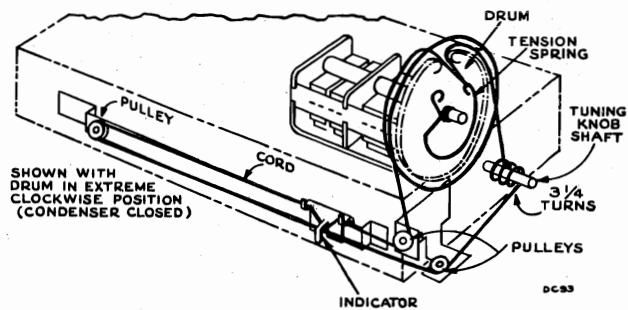

Dial-Indicator and Drive Mechanism

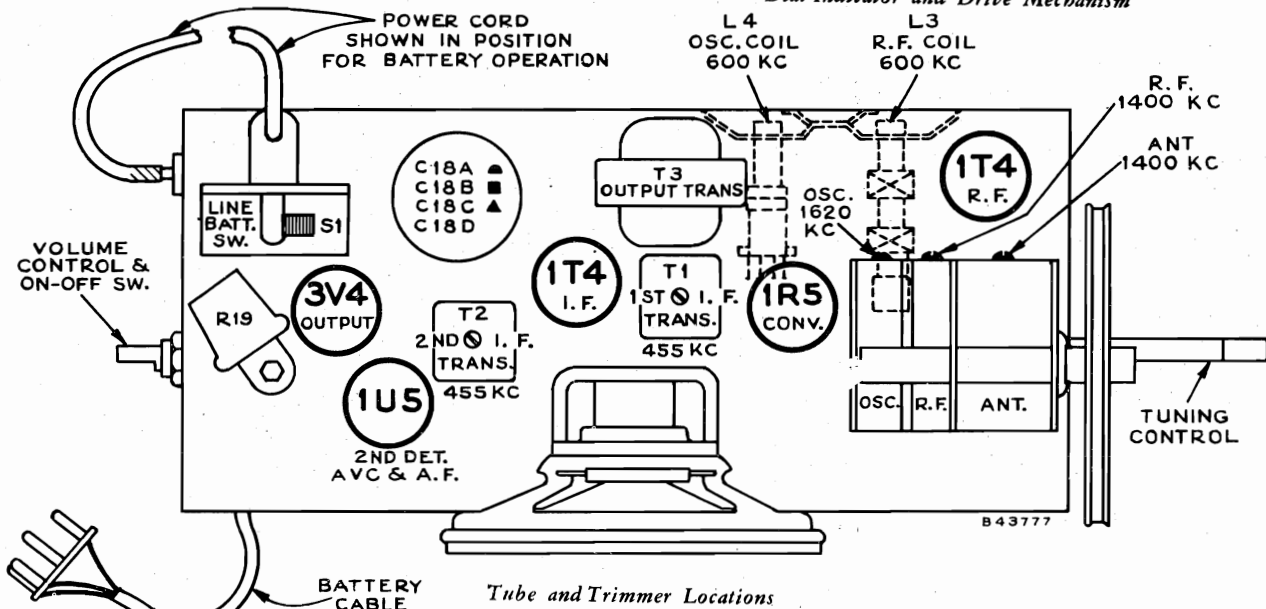

MODEL PX600, Ch. RC-1110

STOCK No.	DESCRIPTION	STOCK No.	DESCRIPTION
CHASSIS ASSEMBLIES RC 1110		503327	27,000 ohms, ±10%, ½ watt R14
		504368	68,000 ohms, ±20%, ½ watt R10
		504410	100,000 ohms, ±20%, ½ watt R5
		504422	220,000 ohms, ±20%, ½ watt R15
76660	Capacitor—Variable tuning capacitor complete with drive drum C1-1, C1-2, C1-3	504510	1 megohm, ±20%, ½ watt R16
73153	Capacitor—Ceramic, 4 mmf. C21	503518	1.8 megohm, ±10%, ½ watt R2
39622	Capacitor—Mica, 56 mmf. C7	504547	4.7 megohm, ±20%, ½ watt R13
71514	Capacitor—Ceramic, 82 mmf. C2, C12	503556	5.6 megohm, ±10%, ½ watt R7
76659	Capacitor—Electrolytic, comprising 1 section of 50 mfd., 150 volts, 1 section of 40 mfd., 150 volts, 1 section of 160 mfd., 25 volts and 1 section of 40 mfd., 25 volts C18A, C18B, C18C, C18D	503533	3.3 megohm, ±10%, ½ watt R8
73595	Capacitor—Tubular, paper, .0022 mfd., 600 volts . C17	503568	6.8 megohm, ±10%, ½ watt R1
73795	Capacitor—Tubular, paper, .0033 mfd., 600 volts . C8	504610	10 megohm, ±20%, ½ watt R12
73796	Capacitor—Tubular, paper, .0039 mfd., 600 volts . C19	76658	Shaft—Tuning knob shaft
73561	Capacitor—Tubular, paper, .01 mfd., 400 volts C13, C16	73117	Socket—Tube socket
73562	Capacitor—Tubular, paper, .022 mfd., 400 volts . C14	76368	Spring—Drive cord spring
73558	Capacitor—Tubular, paper, .047 mfd., 200 volts C4, C5	71039	Switch—"Line-Battery" switch S1
73553	Capacitor—Tubular, paper, .047 mfd., 400 volts C3, C6, C9, C10	71047	Transformer—Output transformer T3
75071	Capacitor—Tubular, moulded paper, .047 mfd., 400 volts C20	73129	Transformer—First I.F. transformer T1
73551	Capacitor—Tubular, paper, 0.1 mfd., 400 volts . C11	75487	Transformer—Second I.F. transformer T2
73935	Clip—Mounting clip for I.F. transformers	33726	Washer—"C" washer for tuning knob shaft
73114	Coil—Oscillator coil complete with adjustable core L4, L5	SPEAKER ASSEMBLIES 971495-2	
74992	Coil—R.F. coil complete with adjustable core . L2, L3	76402	Speaker—4" P.M. speaker complete with cone and voice coil (3.2 ohms)
71041	Connector—5 contact male connector for battery cable	MISCELLANEOUS	
74285	Control—Volume control and power switch . . . R9, S2	76664	Antenna—Antenna loop L1
†72953	Cord—Drive cord (approx. 47" overall length required)	76667	Back—Cabinet back complete with hinges
70022	Cord—Power cord and plug	76661	Board—Antenna loop lead terminal board complete with clip
74838	Grommet—Power cord strain relief (1 set)	76670	Bracket—Carrying handle strap bracket
72283	Grommet—Rubber grommet to mount tuning capacitor (3 required)	76662	Bracket—Mounting bracket for handle (2 required)
18469	Plate—Bakelite mounting plate for electrolytic capacitor	76666	Cabinet—Cabinet complete with escutcheon, dial, "RCA Victor" emblem, grille, baffle and loop—less back and hinges
76656	Pointer—Station selector pointer	74339	Catch—Cabinet back clip catch—fastens to cabinet front (2 required)
72602	Pulley—Drive cord pulley	74790	Hinge—Cabinet hinge (2 required)
74322	Rectifier—Selenium rectifier	76663	Knob—Control knob
74319	Resistor—Wire wound, 2650 ohms, 7 watts R19	76665	Retainer—Retainer for carrying handle strap (2 required)
73237	Resistor—Wire wound, 33 ohms, fuse type R21	74791	Screw—#4 x 5/16" cross recessed pan head thread cutting screw for catch #74339
	Resistors—Fixed, composition:	76671	Screw—#6 x ½" cross recessed round head thread cutting screw for carrying handle
504210	1000 ohms, ±20%, ½ watt R4	74734	Spring—Spring clip for knob
503215	1500 ohms, ±10%, ½ watt R17	76669	Strap—Carrying handle strap
503218	1800 ohms, ±10%, ½ watt R6, R18	76668	Support—Handle assembly support (polystyrene) (2 required)
503227	2700 ohms, ±10%, ½ watt R3		
513233	3300 ohms, ±10%, 1 watt R22		
504315	15,000 ohms, ±20%, ½ watt R20		

†Stock No. 72953 is a reel containing 250 feet of cord.

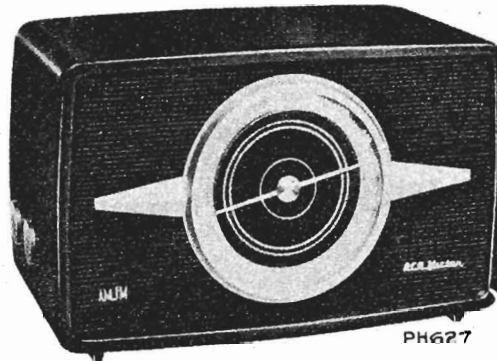

Model 1R81 "Livingston"

Specifications

Tuning Ranges

Standard Broadcast (AM)..... 540-1,600 kc.
 Frequency Modulation (FM) 88-108 mc.

Intermediate Frequency.....AM—455 kc., FM—10.7 mc.

Tube Complement

- (1) RCA 6AU6...Chassis RC-1102.....R. F. Amp.
 RCA 6CB6...Chassis RC-1102A, RC-1102B,
 & RC-1102CR. F. Amp.
- (2) RCA 6X8 Mixer and Oscillator
- (3) RCA 6BA6..... I. F. Amplifier
- (4) RCA 6AU6..... Driver
- (5) RCA 6AL5..... Ratio Detector
- (6) RCA 6AV6..... AM Det.—AVC—A. F. Amp.
- (7) RCA 6V6GT..... Output
- (8) RCA 5Y3GT..... Rectifier

Circuit Description

The receiver is provided with a tuned RF stage (V1 6AU6 or 6CB6) on both AM and FM bands.

The mixer section of the 6X8 tube (V2) operates as a pentode on AM reception and as a triode on FM reception. This provides best signal to noise ratio.

The range switch has five functions:

1. Selection of AM or FM tuning ranges.
2. Selection and distribution of AVC voltages. Full AVC is applied to V1, V2 and V3 in AM position. Delayed AVC is applied to V1 and V3 in FM position (V2 is not controlled).
3. Controls the application of B+ voltages to the plate and screen circuits of V1 and V2 (disconnected in phono position).
4. Controls audio input to volume control.
5. Switches mixer section of V2 (6X8) from pentode operation on AM to triode operation in FM position.

The driver V4 (6AU6) and ratio detector V5 (6AL5) circuits are similar to those used in other RCA Victor AM-FM receivers.

The audio voltage controlled by the volume control is amplified by V6 (6AV6) and V7 (6V6GT).

The rectifier (V8) is type 5Y3GT.

Power Supply Rating..... 115 volts, 60 cycles, 70 watts

Loudspeaker

Type.....8 in. P.M.
 Voice coil impedance at 400 cycles..... 3.2 ohms

Tuning Drive Ratio.....7¼:1 (3⅝ turns of knob)

Dial Lamps (2)..... Type No. 44, 6-8 volts, 0.25 amp.

Power Output

Maximum3.5 watts
 Undistorted2.5 watts

Cabinet Dimensions

Height..10 in. Width..16½ in. Depth..9 in.

Weight19½ lbs.

Antennas:

The receiver has a built-in Ferrite rod antenna for AM band and the FM antenna input is capacity coupled to power line.

Under average conditions the receiver does not require an external antenna. However, provision is made for the use of external antenna if desired—connect as indicated below:

AM antenna: Open the link (normally connects terminals #1 and #2). Connect a single wire antenna to terminal #1.

FM antenna: Remove the built-in antenna lead from #3 terminal. Connect the transmission line (300 ohm) from an external dipole antenna to terminals #2 and #3.

Ground: An external ground can be attached to terminal #2 if desired. Under some conditions an external ground is detrimental to FM reception.

NOTE: For satisfactory reception on FM when using the built-in FM antenna the power cord must be fully extended and must not be coiled or hanked up.

Transformer Substitution:

A few receivers were manufactured using a substitute I.F. transformer (T-3 2nd F.M.). The connections to this transformer differ from that shown in the schematic diagram as follows:

THE ORIGINAL TRANSFORMER IS STAMPED 971169-3.
 IN TRANSFORMERS STAMPED 971169-2, CONNECTIONS TO TERMINALS B AND D ARE INTERCHANGED.
 D IS CONNECTED TO CHASSIS.
 B IS CONNECTED TO NO. 3 TERMINAL OF T4.

MODEL 1R81, Ch. RC1102, A, B, C

ALIGNMENT PROCEDURE—LEAD DRESS

Alignment Procedure

Due to the use of separate I.F. transformers, there is little interaction between the 10.7 mc. and the 455 kc. adjustments.

There is a slight interaction of adjustments on the tuning condenser between AM and FM.

If a large amount of adjustment is required of any circuit, all others should be checked in the following order:

- FM I.F.
- AM I.F.
- AM Osc., ant. and r.f.
- FM Osc., ant. and r.f.

Alignment Indicators:

For measuring the developed d-c voltage across C29 during FM alignment an RCA VoltOhmyst or an equivalent meter should be used. An output meter connected across the voice coil is also needed to indicate minimum audio output during FM Ratio Detector alignment.

The RCA VoltOhmyst can also be used to indicate audio output voltage across the voice coil or developed voltage on the AVC bus.

Signal Generator:

For alignment operations connect the low side of the signal generator to the receiver chassis. The output of the signal generator should always be controlled to prevent over-loading or excessive AVC action.

Oscilloscope Alignment:

It is preferable to use a sweep generator and oscilloscope for aligning I.F. and R.F. circuits to obtain a visual observation of curve shape during alignment.

With FM sweep generator connected between FM ant. (#3) terminal and chassis and oscilloscope connected between the junction of R28-C30 and chassis the overall FM response may be observed. There should be a peak to peak separation of not less than 180 kc. with 50,000 mv. input.

CRITICAL LEAD DRESS

1. Dress diode lead from second I. F. away from filament lead going to 6AV6 1st audio tube socket.
2. Lead from lug terminal "B" of the 1st FM transformer to rear switch wafer terminal #10 should not be changed from the original, 3 inches long plus or minus 1/4" of #22 copper vinylite covered.
3. A.C. leads from power switch on volume control should be dressed as far as possible from the audio-leads and audio coupling condensers near or connecting to the volume control terminals.
4. Ground straps between the R.F. shelf and the main chassis should not be relocated.
5. The connection point of capacitor C10 is critical, therefore should not be altered. It must be connected to the function switch and not to the I.F. transformer.

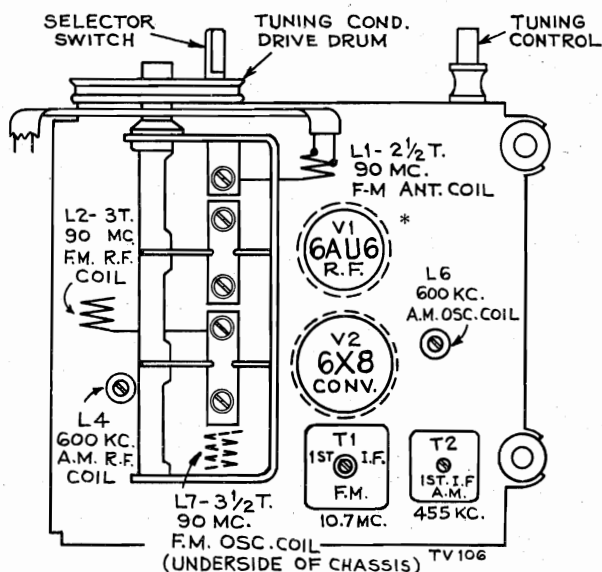

6AU6 is used as R.F. Amp. in RC-1102
6CB6 is used as R.F. Amp. in RC-1102A, RC-1102B, RC-1102C

FM Coil Locations

AM Alignment

RANGE SWITCH IN AM POSITION

Steps	Connect high side of sig. gen. to—	Sig. gen. output	Turn radio dial to—	Adjust for peak output
1	Pin 1 of V3 6BA6 in series with .01 mfd.	455 kc.	Quiet point at low freq. end.	T4 bottom core (pri.). T4 top core (sec.).
2	Pin 7 of V2 6X8 in series with .01 mfd.			T2 top core (sec.). T2 bottom core (pri.).
3	No. 1 terminal on ant. input strip	1620 kc.	High freq. end of dial (min. cap.)	C1-5T
4		1400 kc.	1400 kc. signal	C1-2T ant. C1-3T r.f.
5		Shunt a 10,000 ohm resistor across the r.f. section of the gang.		
6		600 kc.	600 kc. signal	L6 osc.* (Rock gang.)
7		Remove the 10,000 ohm resistor and peak L4 r.f.*		
8	Repeat 3, 4, 5, 6 and 7			

* The correct adjustment of the OSC. (L6) core is that peak obtained with core farthest away from the coil mounting clips. R.F. (L4) core should be set to the peak obtained (2 peaks are seldom obtainable) with core closest to the mounting clips.

FM Alignment

RANGE SWITCH IN FM POSITION — VOLUME CONTROL MAXIMUM

Steps	Connect high side of sig. gen. to—	Sig. gen. output	Turn radio dial to—	Adjust for peak output
1	Connect the d-c probe of a VoltOhmyst to the negative lead of the 2 mfd. capacitor C29 and the common lead to chassis.			
2	Pin 1 of V4 6AU6 in series with .01 mfd.	10.7 mc. modulated 30% 400 cycles AM	Quiet point at low freq. end.	T5 top core for max. d-c voltage across C29. T5 bottom core for min. audio output.*
3	Pin 1 of V3 6BA6 in series with .01 mfd.	Adjust to provide 3 to 4 volts indication on VoltOhmyst during alignment.		†† top core (sec.). T3 bottom core (pri.).
4	Pin 7 of V2 6X8 in series with .01 mfd.			†† top core (sec.). T1 bottom core (pri.).
5	#3 ant. term. in series with a 300 ohm resistor. (Remove ant. lead from #3 term.)	90 mc.	90 mc.	L7 osc.**
6		106 mc.	106 mc. signal	C1-1T ant. C1-4T r.f.
7		90 mc.	90 mc. signal	L1 ant.** L2 r.f.**
8	Repeat Steps 5, 6 and 7 until further adjustment does not improve calibration.			

* Two or more points may be found which lower the audio output. At the correct point the minimum audio output is approached rapidly and is much lower than at any incorrect point.

†† Alternate loading may be necessary to provide accurate observation of peaks.

Alternate loading involves the use of a 680 ohm resistor to load the plate winding while the grid winding of the SAME TRANSFORMER is being peaked. Then the grid winding is loaded with the resistor while the plate winding is peaked. Only one winding is loaded at any one time. Remove the 680 ohm resistor after T3 and T1 have been aligned.

Oscillator frequency is above signal frequency on both AM and FM.

Extreme care should be used to avoid running the I.F. cores all the way through the winding and out the other end. Double peaks or serious overcoupling will result. The correct adjustment may be determined by starting the core all the way out (threads extended). The first peak obtained when tuning should be the correct peak.

** Note: FM antenna, mixer and oscillator coils are adjustable by increasing or decreasing the spacing between turns. The location of the tap on the antenna coil is 1/4 turn ± 1/8 turn from the ground end.

TUBE AND TRIMMER LOCATIONS—VOLTAGE DATA

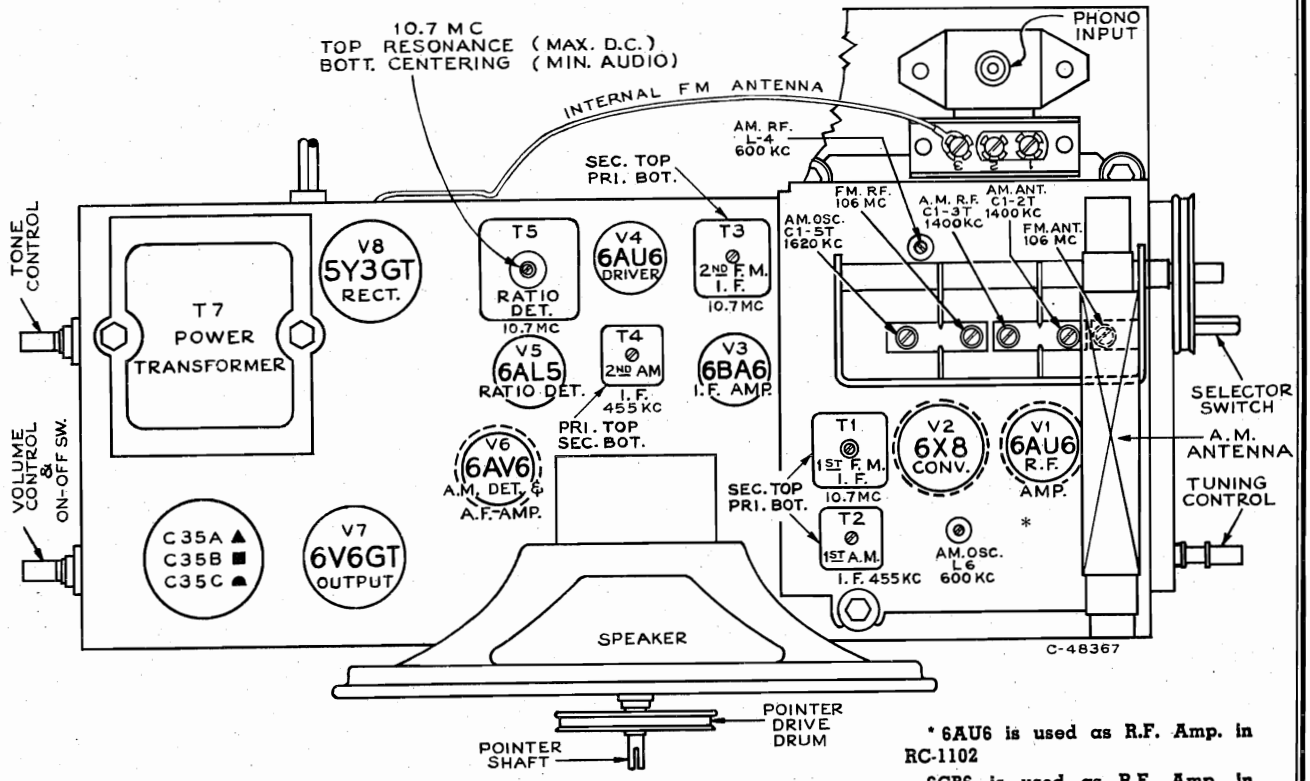

Tube and Trimmer Locations

VOLTAGE CHART

Tube	Type	Elements	Pin No.	"A"	"FM"	Phono.
1	RF amp. 6AU6 (RC-1102)	Plate	5	195	178	—
		Screen	6	100	80	—
		Cathode	7	0.2	0.3	—
	RF amp. 6CB6 (RC-1102A)	Plate	5	195	151	—
		Screen	6	84	64	—
		Cathode	2	0.4	0.45	—
2	Mixer 6X8	Plate	9	64	65	—
		Screen	8	64	65	—
	Osc. 6X8	Grid	7	-3.1	-2.2	—
3	IF amp. 6BA6	Plate	3	83	77	—
		Screen	2	-5.3	-1.1	—
		Grid	2	-5.3	-1.1	—
4	Driver 6AU6	Plate	5	199	202	220
		Screen	6	130	138	150
		Grid	7	1.2	1.2	1.6
		Cathode	7	1.2	1.2	1.6
5	Ratio Det. 6AL5	—	—	—	—	
6	AF amp. 6AV6	Plate	7	72	72	75
		Grid	1	-0.8	-0.7	-0.7
7	Output 6V6GT	Plate	3	244	248	248
		Screen	4	200	210	230
		Cathode	8	10	10.5	12
8	Rectifier 5Y3GT	Fil.	8	260	262	265

The heater voltage of the mixer/oscillator tube (6X8) is approx. .4 volt lower than other tubes in the same circuit. This is due to the filament choke coils L10 and L11.

Voltages and currents measured with tuning condenser closed and no signal input should hold within ±20% with rated line voltage.

RCA VoltOhmyst used for measuring all voltages.

CATHODE CURRENTS (MA)

Tube	Terminal	A.M.	F.M.	Phono	
1	6AU6 (RC-1102)	7	2.9	4.0	—
	6CB6 (RC-1102A)	2	5.1	5.9	—
2	6X8	6	4.6	4.6	—
3	6BA6	7	11.6	13.2	13.6
4	6AU6	7	10.4	10.2	11.2
5	6AL5	—	—	—	—
6	6AV6	2	0.3	0.3	0.36
7	6V6GT	8	34	33.4	37
8	5Y3GT	8	65	66	63

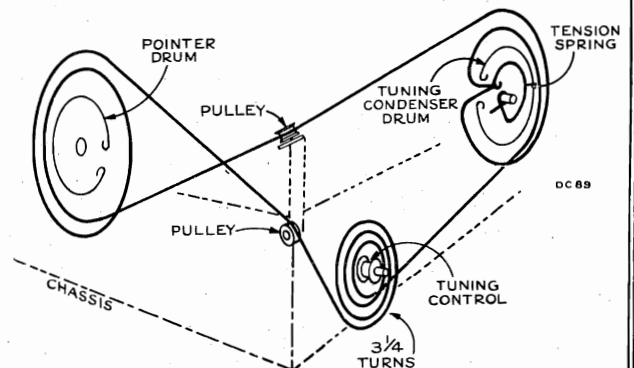

Dial Cord and Drive Assembly

MODEL 1R81, Ch. RC1102, A, B, C

Note: In PHONO operation the I.F. amplifier (6BA6) is "free floating" (not returned to ground) although plate and screen voltages are applied. However the grid cannot go positive due to its being tied to the R.F. amplifier grid thru R35 (1200 ohms) and R1 (2.2 meg.). This would cause the R.F. amplifier grid to conduct as a diode in the event of a positive voltage on it. It is desired to have the I.F. amplifier to draw current under all operating conditions to provide best voltage regulation.

* In Chassis No. RC-1102A the R.F. amplifier (6BA6) is "free floating" (not returned to ground) although plate and screen voltages are applied. However the grid cannot go positive due to its being tied to the R.F. amplifier grid thru R35 (1200 ohms) and R1 (2.2 meg.). This would cause the R.F. amplifier grid to conduct as a diode in the event of a positive voltage on it. It is desired to have the I.F. amplifier to draw current under all operating conditions to provide best voltage regulation.

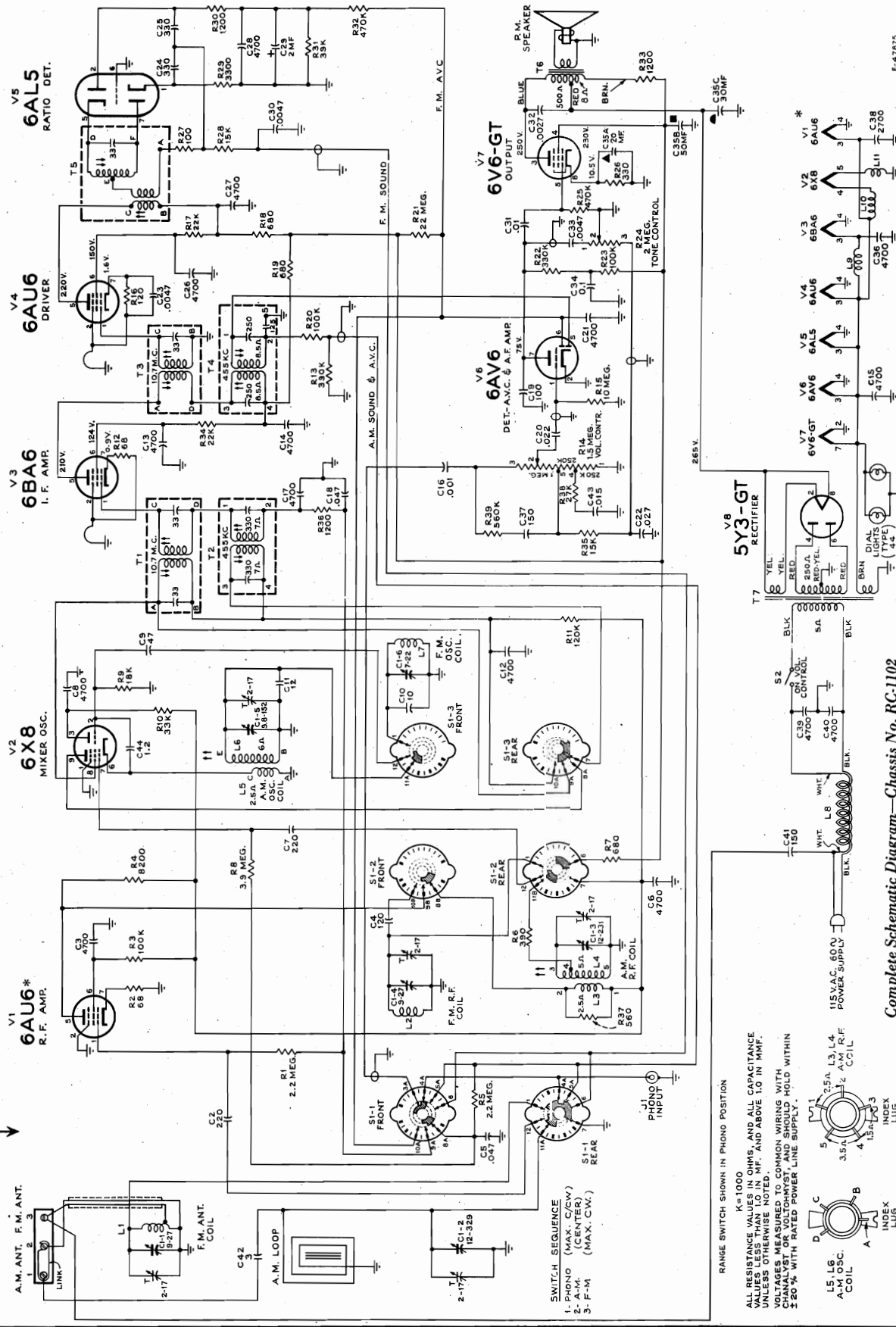

ALL RESISTANCE VALUES IN OHMS, AND ALL CAPACITANCE VALUES LESS THAN 10 IN. MF. AND ABOVE 1.0 IN MMF. VOLTAGES MEASURED TO COMMON WIRING WITH CHANNELYST OR VOLTOHMYST, AND SHOULD HOLD WITHIN ±20% WITH RATED POWER LINE SUPPLY.

RANGE SWITCH SHOWN IN PHONO POSITION

K=1000

L5, L6 AC 110.00C. COIL

L3, L4 2.5A. L3, L4 1/2 A.M. R.F. COIL

INDEX LUG

INDEX LUG

MODEL 1R81, Ch. RC1102, A, B, C

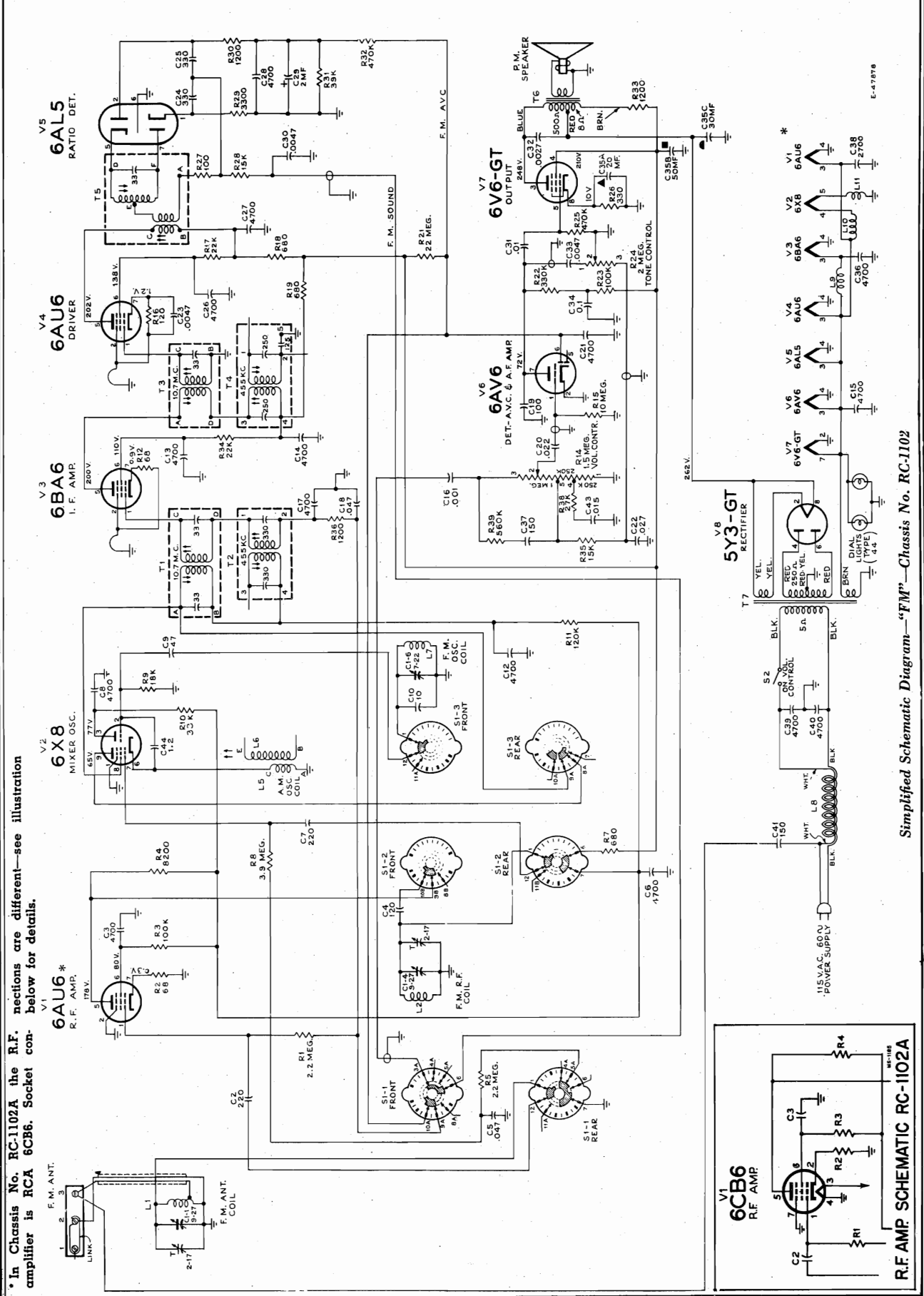

* In Chassis No. RC-1102A the R.F. sections are different—see illustration amplifier is RCA 6CB6. Socket con- below for details.

Simplified Schematic Diagram—"FM"—Chassis No. RC-1102

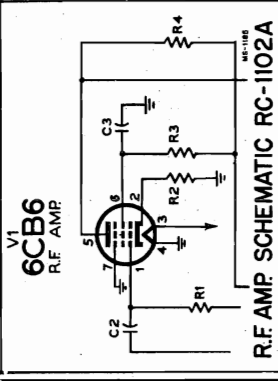

Note:
In PHONO operation the I.F. amplifier (6BA6) grid is "free floating" (not returned to ground) although plate and screen voltages are applied. However the grid cannot go positive due to its being tied to the R.F. amplifier grid thru R36 (1200 ohms) and R1 (2.2 meg.). This would cause the R.F. amplifier grid to conduct as a diode in the event of a positive voltage on it. It is desired to have the I.F. amplifier to draw current under all operating conditions to provide best voltage regulation.

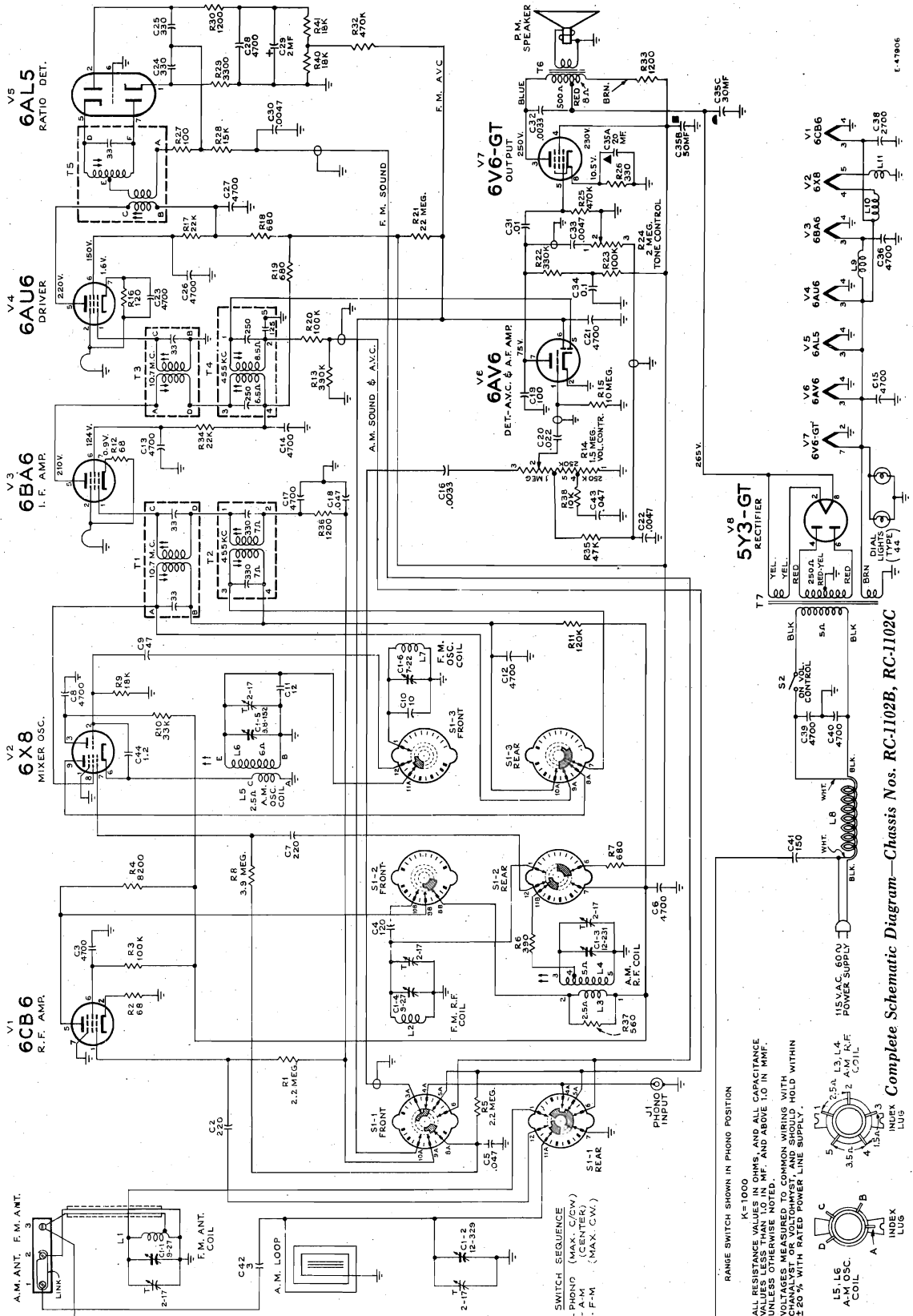

SWITCH SEQUENCE
1- PHONO (MAX. C/W)
2- F.M. (CENTER)
3- F.M. (MAX. C/W)

RANGE SWITCH SHOWN IN PHONO POSITION
K=1000
ALL RESISTANCE VALUES IN OHMS, AND ALL CAPACITANCE VALUES LESS THAN 100 PF. AND ABOVE 1.0 IN MMF. VOLTAGES MEASURED TO COMMON WIRING WITH CHANNELYST OR VOLTOHMYST, AND SHOULD HOLD WITHIN ± 20% WITH RATED POWER LINE SUPPLY.

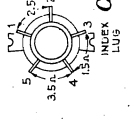

Complete Schematic Diagram—Chassis Nos. RC-1102B, RC-1102C

MODEL 1R81, Ch. RC1102, A, B, C

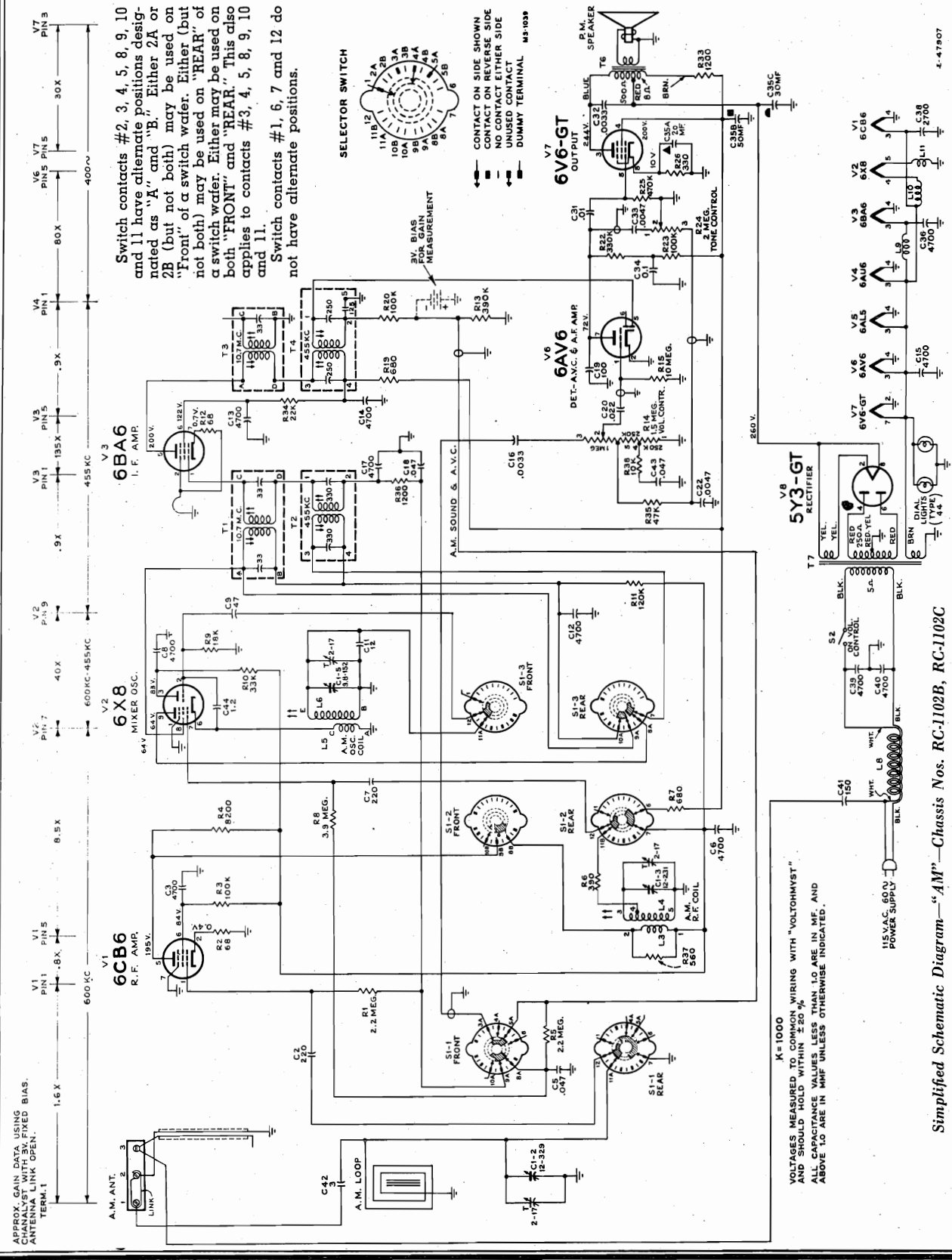

Simplified Schematic Diagram—"AM"—Chassis Nos. RC-1102B, RC-1102C

K = 1000
 VOLTAGES MEASURED TO COMMON WIRING WITH "VOLTOMHYST"
 AND SHOULD HOLD WITHIN ±20 %
 ALL CAPACITANCE VALUES LESS THAN 1.0 ARE IN MF. AND
 ABOVE 1.0 ARE IN MHF UNLESS OTHERWISE INDICATED.

Switch contacts #2, 3, 4, 5, 8, 9, 10 and 11 have alternate positions designated as "A" and "B." Either 2A or 2B (but not both) may be used on "Front" of a switch wafers. Either (but not both) may be used on "REAR" of a switch wafers. Either may be used on both "FRONT" and "REAR." This also applies to contacts #3, 4, 5, 8, 9, 10 and 11.
 Switch contacts #1, 6, 7 and 12 do not have alternate positions.

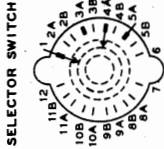

4-47907

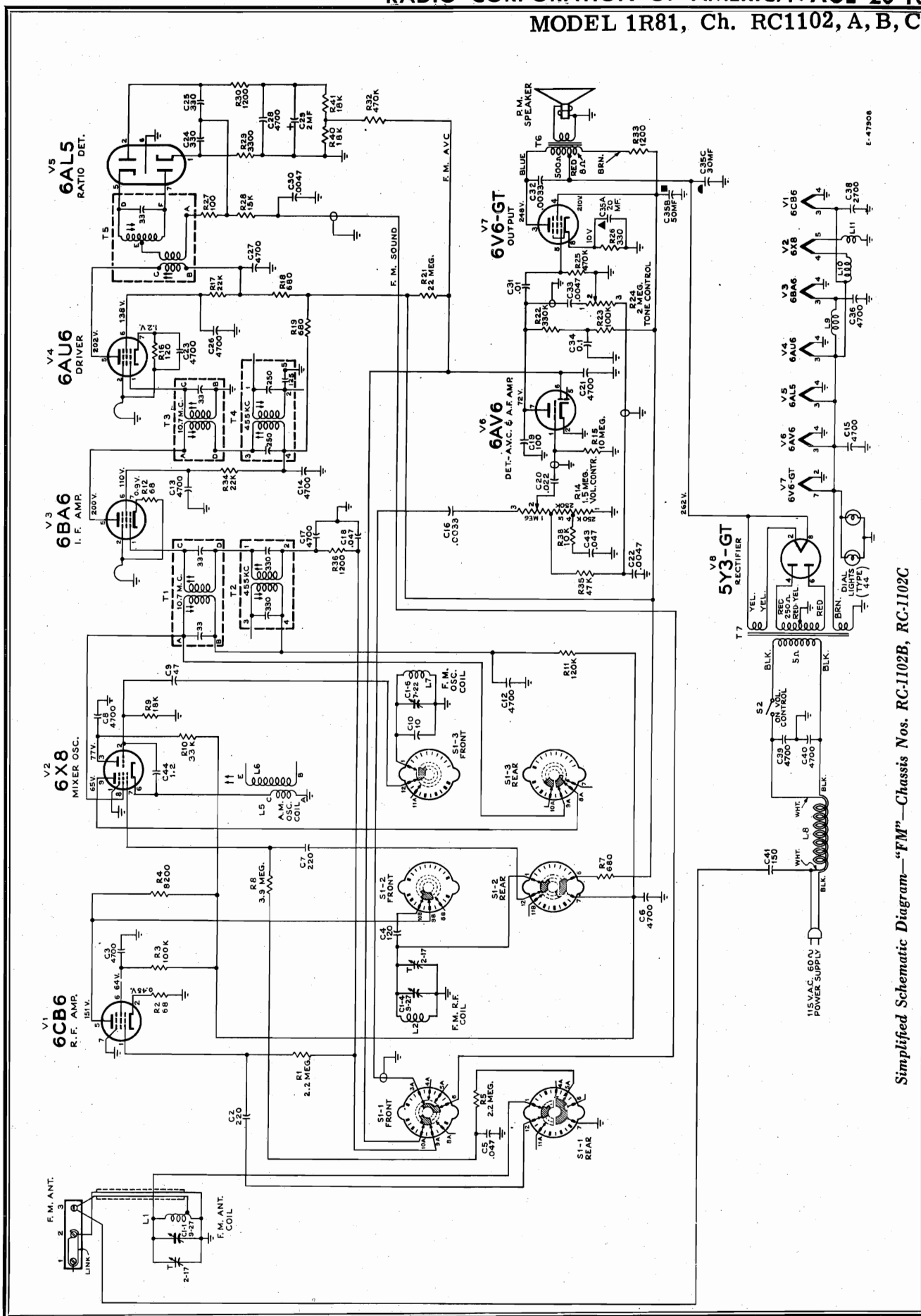

E-47908

Simplified Schematic Diagram—"FM"—Chassis Nos. RC-1102B, RC-1102C

MODEL 1R81, Ch. RC1102, A, B, C

Stock No.	DESCRIPTION	Stock No.	DESCRIPTION
CHASSIS ASSEMBLIES RC 1102, RC 1102A			
76343	Antenna—Ferrite rod antenna complete with coil less masonite support and grommets	503233	3,300 ohms, ±10%, 1/2 watt (R29)
12717	Board—Antenna terminal board	503282	8,200 ohms, ±10%, 1/2 watt (R4)
76325	Bracket—Drive cord pulley bracket with two (2) pulleys	503310	10,000 ohms, ±10%, 1/2 watt (R38 in RC-1102B, RC-1102C)
76333	Capacitor—Variable tuning capacitor (C1-1, C1-2, C1-3, C1-4, C1-5, C1-6)	503315	15,000 ohms, ±10%, 1/2 watt (R28) (R35 in RC-1102, RC-1102A)
76677	Capacitor—Ceramic, 1.2 mmf. (C44)	503318	18,000 ohms, ±10%, 1/2 watt (R9) (R40, R41, in RC-1102B, RC-1102C)
57090	Capacitor—Ceramic, 3 mmf. (C42)	503322	22,000 ohms, ±10%, 1/2 watt (R17, R34)
76350	Capacitor—Ceramic, 10 mmf. (C10)	503327	27,000 ohms, ±10%, 1/2 watt (R38 in RC-1102, RC-1102A)
76349	Capacitor—Ceramic, 12 mmf. (C11)	513333	33,000 ohms, ±10%, 1 watt (R10)
76348	Capacitor—Ceramic, 47 mmf. (C9)	503339	39,000 ohms, ±10%, 1/2 watt (R31 in RC-1102, RC-1102A)
75437	Capacitor—Ceramic, 100 mmf. (C19)	503347	47,000 ohms, ±10%, 1/2 watt (R35 in RC-1102B, RC-1102C)
76347	Capacitor—Ceramic, 120 mmf. (C4)	503410	100,000 ohms, ±10%, 1/2 watt (R3, R20, R23)
44202	Capacitor—Ceramic, 150 mmf. (C37 in RC-1102, RC-1102A)	503412	120,000 ohms, ±10%, 1/2 watt (R11)
39632	Capacitor—Mica, 150 mmf. (C41)	503433	330,000 ohms, ±10%, 1/2 watt (R22)
75611	Capacitor—Ceramic, 220 mmf. (C2, C7)	503439	390,000 ohms, ±10%, 1/2 watt (R13)
39640	Capacitor—Mica, 330 mmf. (C24, C25)	504447	470,000 ohms, ±20%, 1/2 watt (R25, R32)
39662	Capacitor—Mica, 2700 mmf. (C38)	503456	560,000 ohms, ±10%, 1/2 watt (R39 in RC-1102, RC-1102A)
73473	Capacitor—Ceramic, 4700 mmf. (C3, C6, C8, C13, C14, C15, C17, C21) (C23 in RC-1102B, RC-1102C) (C26, C27, C28, C36, C39, C40)	504522	2.2 megohm, ±20%, 1/2 watt (R1, R5)
39668	Capacitor—Mica, 4700 mmf. (C12)	503559	3.9 megohm, ±10%, 1/2 watt (R8)
73747	Capacitor—Electrolytic, 2 mfd., 50 volts (C29)	504610	10 megohm, ±20%, 1/2 watt (R15)
76330	Capacitor—Electrolytic comprising 1 section of 30 mfd., 350 volts, 1 section of 50 mfd., 300 volts and 1 section of 20 mfd., 25 volts (C35A, C35B, C35C)	504622	22 megohm, ±20%, 1/2 watt (R21)
75249	Capacitor—Tubular, paper, .001 mf., 600V (C16 in RC-1102, RC-1102A)	76339	Shaft—Tuning knob shaft
73818	Capacitor—Tubular, paper, .0027 mf., 1600V (C32 in RC-1102, RC-1102A)	73584	Shield—Tube shield for V1, V6
73795	Capacitor—Tubular, paper, .0033 mf., 600V (C16 in RC-1102B, RC-1102C)	76331	Shield—Tube shield for V2
73819	Capacitor—Tubular, paper, .0033 mf. 1600V (C32 in RC-1102B, RC-1102C)	35787	Socket—Phono input socket (J1)
73920	Capacitor—Tubular, paper, .0047 mf., 600V (C22 in RC-1102B, RC-1102C) (C23 in RC-1102, RC-1102A) (C30, C33)	73117	Socket—Tube socket, 7 pin, miniature
73561	Capacitor—Tubular, paper, .01 mfd., 400 volts (C31)	70827	Socket—Tube socket, octal, wafer
73797	Capacitor—Tubular, paper, .015 mf., 600V (C43 in RC-1102, RC-1102A)	76336	Socket—Tube socket, 9 pin, miniature, saddle mounted
73562	Capacitor—Tubular, paper, .022 mfd., 400 volts (C20)	35574	Socket—Dial lamp socket
73554	Capacitor—Tubular, paper, .027 mf., 400V (C22 in RC-1102, RC-1102A)	76332	Spring—Drive cord spring
73558	Capacitor—Tubular, paper, .047 mf., 200V (C5, C18) (C43 in RC-1102B, RC-1102C)	76342	Support—Antenna support (masonite) only
73784	Capacitor—Tubular, paper, 0.1 mfd., 200 volts (C34)	76334	Switch—Function switch (S1-1, S1-2, S1-3)
73935	Clip—Mounting clip for A.M.—I.F. transformers	76326	Transformer—Power transformer 117 volt 60 cycle (T7)
76337	Coil—Oscillator coil—A.M.—complete with adjustable core (L5, L6)	76327	Transformer—Output transformer (T6)
76338	Coil—RF coil—A.M.—complete with adjustable core (L3, L4)	73743	Transformer—Ratio detector transformer (T5)
76352	Coil—Oscillator coil—F.M. (L7)	76335	Transformer—First I.F. transformer—A.M. (T2)
76353	Coil—RF coil—F.M. (L2)	75559	Transformer—First I.F. transformer—F.M. (T1)
76354	Coil—Antenna coil—F.M. (L1)	76328	Transformer—Second I.F. transformer—A.M. (T4)
71942	Coil—Filament choke coil (L9)	76329	Transformer—Second I.F. transformer—F.M. (T3)
76351	Coil—Filament choke coil (L10, L11)	33726	Washer—"C" washer for tuning knob shaft or for station selector shaft and pulley
70342	Control—Volume control and power switch (R14, S2)	SPEAKER ASSEMBLIES	
75538	Control—Tone control (R24)	Stamped 92586-6W, 92586-7W or 92586-8W RMA 274	
70392	Cord—Power cord and plug	75023	Cap—Dust cap
172953	Cord—Drive cord (approx. 51" overall length required)	75024	Cone—Cone and voice coil assembly (3.2 ohms)
74839	Fastener—Push fastener for RF shelf mounting (4 req'd)	76392	Speaker—8" P.M. (92586-7W) speaker complete with cone and voice coil
74838	Grommet—Power cord strain relief (1 set)	74664	Speaker—3" P.M. speaker (92586-8W) complete with cone and voice coil
16058	Grommet—Rubber grommet for RF shelf (4 req'd)	MISCELLANEOUS	
76344	Grommet—Rubber grommet for mounting ferrite rod antenna to masonite support (2 req'd)	76359	Back—Cabinet back
76345	Insert—Hard rubber insert for antenna mounting grommets (2 req'd)	76355	Bezel—Decorative bezel—round—for front of cabinet
76340	Pan—Speaker pan assembly complete less station selector pointer shaft and pulley	Y2328	Cabinet—Plastic cabinet—maroon
76341	Pulley—Station selector pointer shaft and pulley	76678	Clip—Spring clip for cabinet back
76346	Resistor—Wire wound, 1200 ohms, 4 watts (R33)	76363	Decal—Control function decal—early type (below knobs)
503068	Resistors—Fixed, composition:	76767	Decal—Control function decal—late type (above knobs)
503110	68 ohms, ±10%, 1/2 watt (R2, R12)	76356	Dial—Polystyrene dial scale
503112	100 ohms, ±10%, 1/2 watt (R27)	74782	Emblem—"RCA Victor" emblem
513133	120 ohms, ±10%, 1/2 watt (R16)	76360	Knob—Function switch knob—type #1
503139	330 ohms, ±10%, 1 watt (R26)	73378	Knob—Function switch knob—type #2
503156	390 ohms, ±10%, 1/2 watt (R6)	75712	Knob—Function switch knob—type #3
503168	560 ohms, ±10%, 1/2 watt (R37)	76765	Knob—Function switch knob—type #4
503212	680 ohms, ±10%, 1/2 watt (R7, R18, R19)	76361	Knob—tuning control, tone control or volume control and power switch knob—type #1
	1,200 ohms, ±10%, 1/2 watt (R30, R36)	74711	Knob—tuning control, tone control or volume control and power switch knob—type #2
		75714	Knob—tuning control, tone control or volume control and power switch knob—type #3
		76766	Knob—tuning control, tone control or volume control and power switch knob—type #4
		11891	Lamp—Dial lamp—Mazda 44
		76425	Nameplate—"AM-FM" nameplate (tenite)
		72765	Nut—Speed nut to fasten bezel assembly (4 req'd)
		76362	Pointer—Station selector pointer
		76357	Reflector—Dial scale reflector
		76358	Screen—Grille screen
		74734	Spring—Retaining spring for knobs—types #1, #3, and #4
		14270	Spring—Retaining spring for knobs—type #2

†Stock No. 72953 is a reel containing 250 feet of cord.

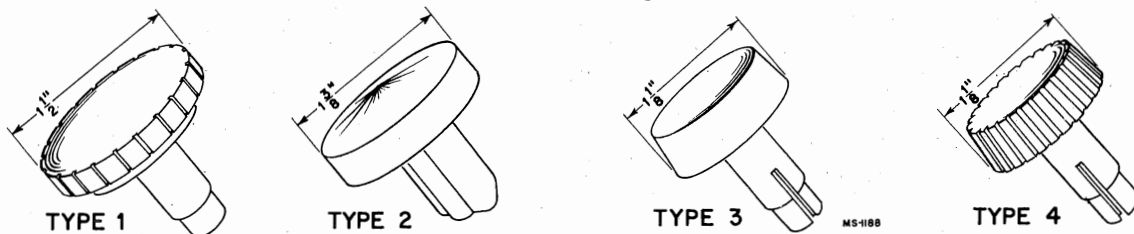

Differing Types of Knobs—Model 1R81

Change in Parts List:

CHASSIS ASSEMBLIES		Add:
Delete:		77232
76347	Capacitor—Ceramic, 120 mmf (C4)	77233
73784	Capacitor—Tubular, paper, 0.1 mf, 200 volts (C34)	
Add:		
76958	Capacitor—Ceramic, 120 mmf (C4)	
73551	Capacitor—Tubular, paper, 0.1 mf, 400 volts (C34)	

MISCELLANEOUS

- Knob—Function switch knob—type 5
 - Knob—Tuning control, tone control or volume control and power switch knob—type 5
- (Type 5 knob is illustrated)

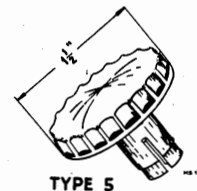

SPECIFICATIONS

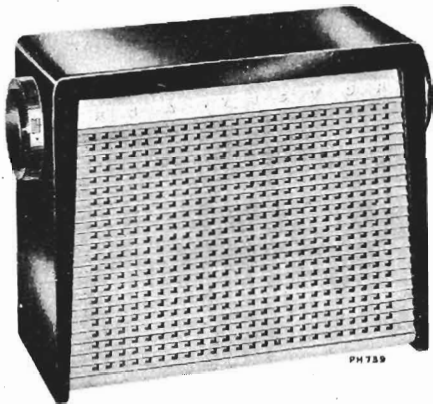

2R51
Black & Gray

2R52
Tan & Ivory

Tuning Range 540-1600 kc
 Intermediate Frequency 455 kc

Tube Complement:

- (1) RCA 12BE6 Converter
 - (2) RCA 6BJ6 I.F. Amplifier
 - (3) RCA 12AV6 Det.-AVC-A.F. Amp.
 - (4) RCA 6AK6 Output
- RCA Stock No. 77292 Rectifier

Dial Lamp (1) Type No. 51, 6-8 volts, 0.2 amp.

Power Supply Rating:

115 volts a.c., 60 cycles 18 watts

CAUTION:—DO NOT OPERATE ON D.C.

Loudspeaker:

Size and type 4 x 6 in. P.M.
 Voice Coil impedance 3.2 ohms at 400 cycles

Power Output:

Undistorted 0.30 watts
 Maximum 0.45 watts

Tuning Drive Ratio 1 to 1 (Direct Drive)

Weight 4 lbs.

Cabinet Dimensions:

Height... 5 $\frac{5}{8}$ " Width... 8 $\frac{3}{8}$ " Depth... 3 $\frac{5}{8}$ "

Top View

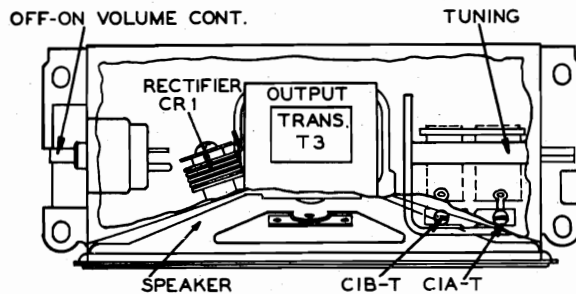

Tube and Trimmer Locations

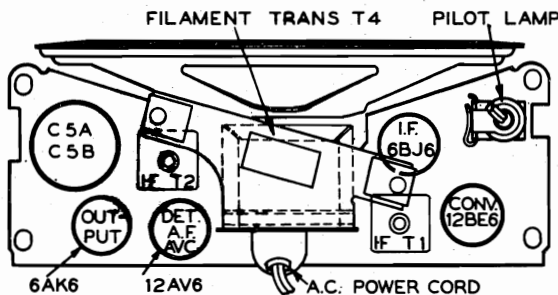

Bottom View

CRITICAL LEAD DRESS

1. Oscillator coil should be centered in space provided and have at least 1/4 inch between winding and chassis.
2. The filament wiring should be dressed down on chassis and away from audio leads and audio coupling condensers.
3. The I.F. plate and grid leads, including the 2nd I.F. diode lead should be as short as practical.

4. The output plate by pass condenser should be dressed against the side of the chassis and away from the 1st audio grid condenser and the diode filter resistor.
5. Output transformer primary leads should be dressed away from the selenium rectifier.
6. The loop antenna should be accurately centered in its position on the fishpaper cover. The ends must not project beyond the fishpaper.

ALIGNMENT PROCEDURE

Test-Oscillator—For all alignment operations, connect the low side of the test-oscillator to the receiver chassis, and keep the oscillator output as low as possible to avoid a-v-c action.

On a.c. operation an isolation transformer (115 v./115 v.) may be necessary for the receiver if the test oscillator is also a.c. operated.

Output Meter—Connect meter across speaker voice coil. Turn volume control to maximum.

Step	Connect the high side of test-oscillator to—	Tune test-osc. to—	Turn radio dial to—	Adjust the following for max. output
1	6BJ6 I-F grid through .01 mfd. capacitor	455 kc	Quiet-point 1600 kc end of dial	T2 (top and bottom) 2nd I-F. trans.
2	Stator of CIA through .01 mfd.			T1 (top and bottom) 1st I-F trans.
3	Short wire placed near loop to radiate signal	1620 kc	Min. cap.	osc. trimmer C1B-T
4		1400 kc	1400 kc signal	ant. trimmer CIA-T
5		Repeat steps 3 and 4		

MODELS 2-R-51, 2-R-52

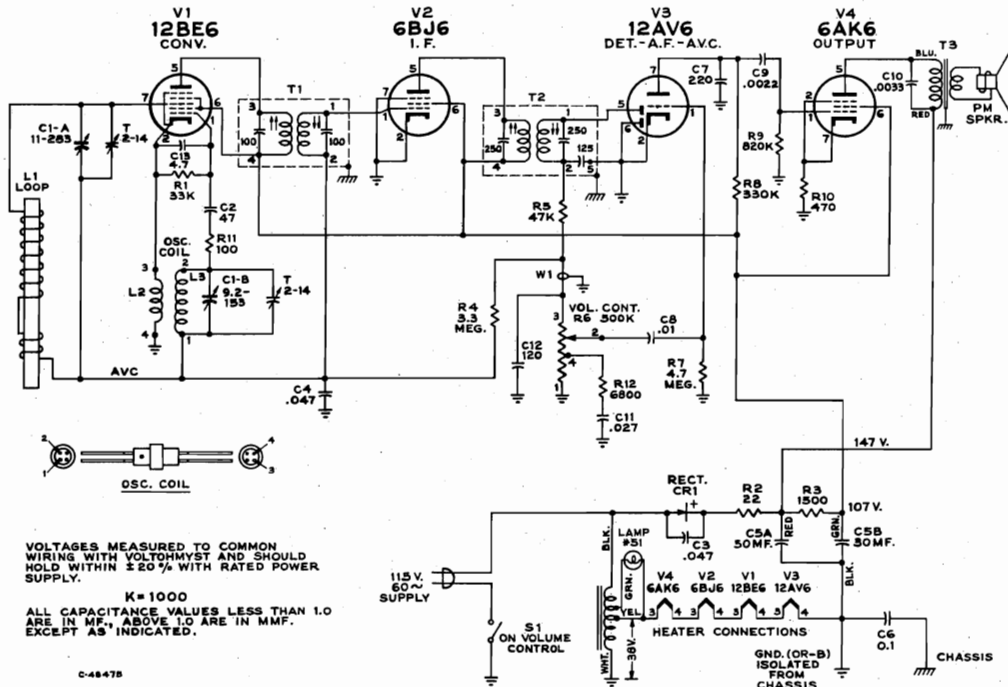

Schematic Diagram

STOCK NO.	DESCRIPTION	STOCK NO.	DESCRIPTION
	CHASSIS ASSEMBLIES		
	RC 1119-2R51 RC 1119A-2R52	503547	4.7 megohm, ±10%, 1/2 watt.....R7
77438	Antenna—Ferrite rod antenna complete with windings.....L1	76723	Socket—Lamp socket
77440	Capacitor—Variable tuning capacitor.....C1A, C1B	75780	Socket—Tube socket, 7 pin, miniature saddle-mounted
77471	Capacitor—Ceramic, 4.7 mmf.....C13	77441	Transformer—Filament transformer 117 volts AC.....T4
75609	Capacitor—Ceramic, 47 mmf.....C2	74445	Transformer—Output transformer.....T3
76347	Capacitor—Ceramic, 120 mmf.....C12	77416	Transformer—1st I.F. transformer complete with adjustable cores.....T1
75611	Capacitor—Ceramic, 220 mmf.....C7	77417	Transformer—2nd I.F. transformer complete with adjustable cores.....T2
77443	Capacitor—Electrolytic comprising 1 section of 50 mfd., 150 volts and 1 section of 30 mfd., 150 volts.....CSA, C5B	77420	Washer—Shoulder washer (nylon) for mounting variable tuning capacitor
77446	Capacitor—Tubular, paper, .0022 mfd., 400 volts.....C9		SPEAKER ASSEMBLIES
77447	Capacitor—Tubular, paper, .0033 mfd., 400 volts.....C10		922258-7
77424	Capacitor—Tubular, paper, .01 mfd., 200 volts.....C8	77451	Speaker—4" x 6" P.M. speaker complete with cone and voice coil (3.2 ohms)
77448	Capacitor—Tubular, paper, .027 mfd., 200 volts.....C11		MISCELLANEOUS
77422	Capacitor—Tubular, paper, .047 mfd., 400 volts.....C4	77457	Case—Polystyrene case—black & beige—complete with speaker baffle and screen assemblies less bottom cover for Model 2R51
75071	Capacitor—Tubular, moulded paper, .047 mfd., 400 volts.....C3	77465	Case—Polystyrene case—tan & ivory—complete with speaker baffle and screen assemblies less bottom cover for Model 2R52
77423	Capacitor—Tubular, paper, 0.1 mfd., 400 volts.....C6	77456	Clip—Spring clip to mount station selector pointer
73935	Clip—Mounting clip for I.F. transformer	77458	Cover—Bottom cover—beige—for Model 2R51
77450	Coil—Oscillator coil.....L2, L3	77466	Cover—Bottom cover—ivory—for Model 2R52
77442	Control—Volume control and power switch.....R6, S1	77453	Dial—Dial knob—black & gold—for Model 2R51
70392	Cord—Power cord and plug	77464	Dial—Dial knob—tan & gold—for Model 2R52
77439	Cover—Insulating cover for chassis	77452	Knob—Volume control and power switch knob—black & gold—for Model 2R51
74838	Grommet—Power cord strain relief (1 set)	77463	Knob—Volume control and power switch knob—tan & gold—for Model 2R52
77405	Insulator—Bakelite insulator for variable tuning capacitor	11765	Lamp—Pilot lamp—Mazda 51
77444	Nut—Speed nut for output transformer mounting screws	77455	Pointer—Station selector pointer
28452	Plate—Bakelite mounting plate for electrolytic	77454	Screw—#8-32 x 3/8" cross recessed truss head machine screw for fastening bottom cover
77292	Rectifier—Selenium rectifier.....CR1	76783	Shield—Pilot lamp shield
77571	Resistor—Wire wound, fuse type, 22 ohms, 0.4 amps.....R2	74734	Spring—Spring clip for volume control knob or dial knob
	Resistor—Fixed, composition:—		
503110	100 ohms, ±10%, 1/2 watt.....R11		
503147	470 ohms, ±10%, 1/2 watt.....R10		
523215	1500 ohms, ±10%, 2 watts.....R3		
503268	6800 ohms, ±10%, 1/2 watt.....R12		
503333	33,000 ohms, ±10%, 1/2 watt.....R1		
503347	47,000 ohms, ±10%, 1/2 watt.....R5		
503433	330,000 ohms, ±10%, 1/2 watt.....R8		
503482	820,000 ohms, ±10%, 1/2 watt.....R9		
503533	3.3 megohm, ±10%, 1/2 watt.....R4		

APPLY TO YOUR RCA DISTRIBUTOR FOR PRICES OF REPLACEMENT PARTS

MODELS 1X591, Ch.
RC1079K; 1X592, Ch.
RC1079L



1X591
Maroon

1X592
Ivory

Specifications

Tuning Range 540-1600 kc
Intermediate Frequency 455 kc
Tube Complement
 (1) RCA 12SA7 Converter
 (2) RCA 12SK7 I-F Amplifier
 (3) RCA 12SQ7 Det.—A.V.C.—A-F Amp.
 (4) RCA 50L6GT Output
 (5) RCA 35Z5GT Rectifier
Power Supply Rating
 115 volts a.c., 50 to 60 cycles or d.c. 30 watts

Power Output
 Undistorted85 watts
 Maximum 1.1 watts
Dial Lamps (2) Mazda type 1490, 3.2 volts, .16 amp.
Loudspeaker
 Size and Type 8 in. PM
 Voice Coil Impedance 3.2 ohms at 400 cycles
Cabinet Dimensions
 Height 9½" Width 12½" Depth 8½"
Weight 9 lbs.
Tuning Drive Ratio 9 to 1 (4½ turns of knob)

Alignment Procedure

Lead Dress

1. Dress all heater leads down to chassis and away from all audio grid and plate wiring.
2. Dress power cord against chassis base.
3. Dress capacitor C18 against back apron.
4. Dress capacitor C13 down to base alongside of shielded lead.
5. Dress output transformer leads down to chassis.
6. Dress capacitors C9 and C15 as direct as possible.
7. Dress dial lamp leads on top of chassis between 12SQ7 and 50L6GT tubes; below chassis, as short as possible to rectifier socket.
8. Dress excess loop leads away from tubes and clear of tuning condenser.

Test-Oscillator.—For all alignment operations, connect the low side of the test-oscillator to the receiver chassis, and keep the oscillator output as low as possible to avoid a-v-c action.

On AC operation an isolation transformer (115 v./115 v.) may be necessary for the receiver if the test oscillator is also AC operated.

Dial Calibration

With the tuning condenser fully meshed, the dial pointer should be set to the first score mark at the left-hand end of the dial back plate. The four score marks represent:
 Max cap. 600 kc 1400 kc min. cap.

Steps	Connect the high side of test-oscillator to—	Tune test-osc. to—	Turn radio dial to—	Adjust the following for max. output
1	12SK7 I-F grid through 0.1 mfd. capacitor	455 kc	Quiet-point 1600 kc end of dial	T2 (top and bottom) 2nd I-F trans.
2	Stator of C1 through 0.1 mfd.			*T1 (top and bottom) 1st I-F trans.
3	Short wire-placed near loop to radiate signal	1620 kc	Min. cap.	C4 (osc.)
4		1400 kc	1400 kc signal	†C2 (ant.)
5		600 kc	600 kc signal	L3 (osc.) Rock gang
6	Repeat steps 3, 4 and 5.			

* Do not readjust T2 when test oscillator is connected to C1.

† When adjusting C2 (ant. trimmer) it is necessary to have the speaker and loop in the same position and spacing as they will have when assembled in the cabinet.

POWER SUPPLY POLARITY.—For operation on d.c., the power plug must be inserted in the outlet for correct polarity. If the set does not function, reverse the plug. On a.c., reversal of the plug may reduce hum.

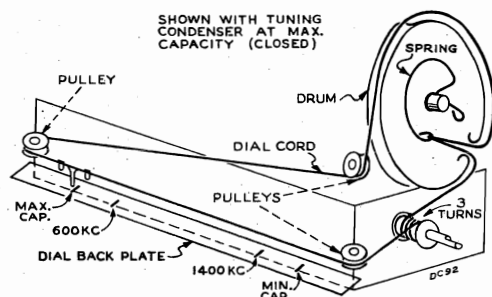

Dial Indicator and Drive Cord

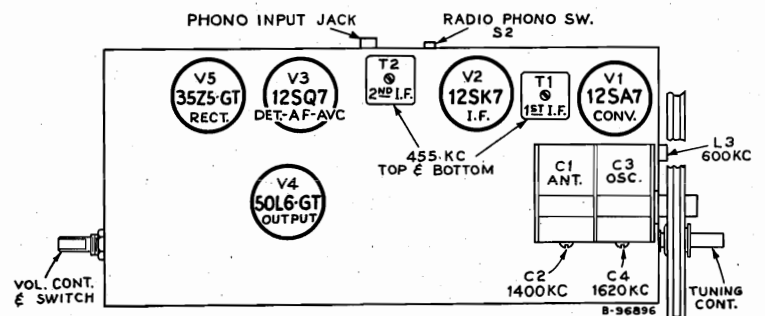

Tube and Trimmer Locations

8-3-51

PAGE 23-18 RADIO CORPORATION OF AMERICA
MODELS 1X591, Ch. RC1079K; 1X592, Ch. RC1079L

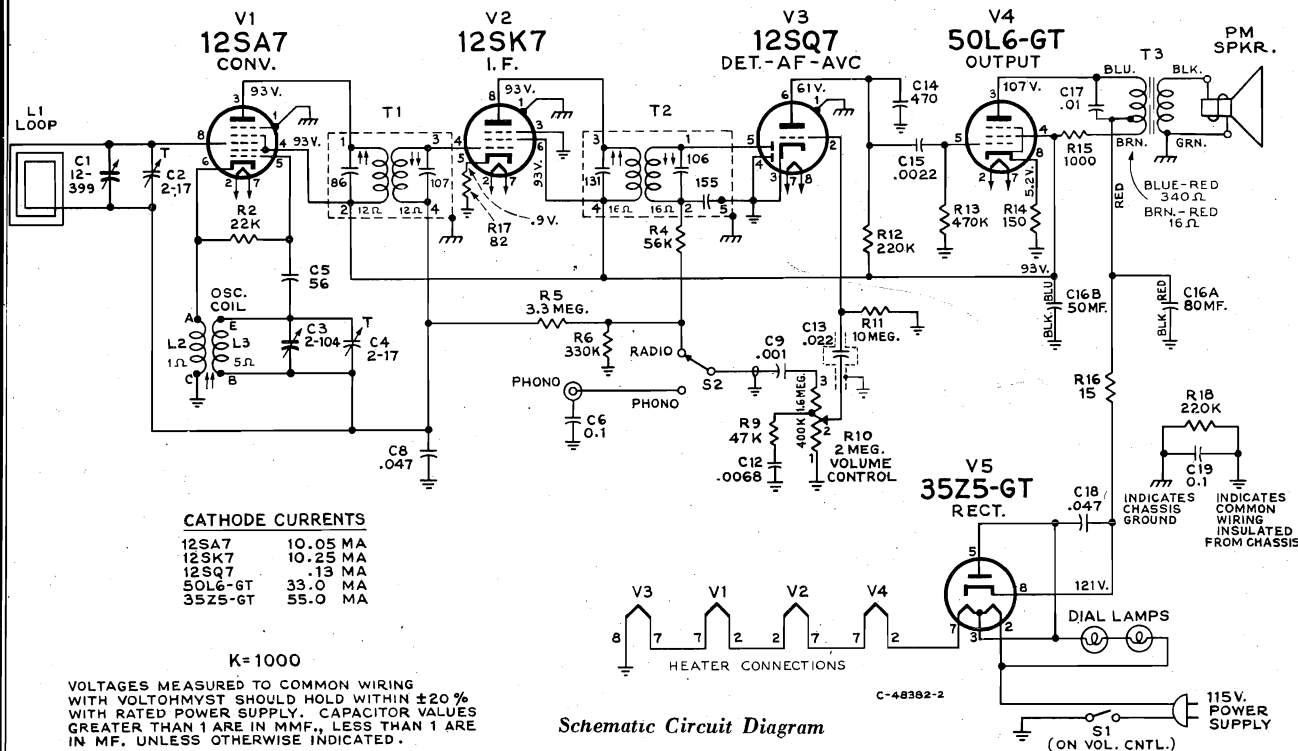

Stock No.	DESCRIPTION	Stock No.	DESCRIPTION
	CHASSIS ASSEMBLIES		
	RC 1079K—1X591	503422	220,000 ohms, ±10%, 1/2 watt (R12, R18)
	RC 1079L—1X592	503433	330,000 ohms, ±10%, 1/2 watt (R6)
76584	Antenna—Antenna loop and back cover (L1)	503447	470,000 ohms, ±10%, 1/2 watt (R13)
74653	Capacitor—Variable tuning capacitor (C1, C2, C3, C4)	503533	3.3 megohm, ±10%, 1/2 watt (R5)
71924	Capacitor—Ceramic, 56 mmf. (C5)	503610	10 megohm, ±10%, 1/2 watt (R11)
75198	Capacitor—Ceramic, 470 mmf. (C14)	74659	Shaft—Tuning knob shaft and pulley
74662	Capacitor—Electrolytic, comprising 1 section of 80 mfd., 150 volts, and 1 section of 50 mfd., 150 volts (C16A, C16B)	74697	Socket—Dial lamp socket
75843	Capacitor—Tubular, paper, .001 mfd., 1000 volts (C9)	31251	Socket—Tube socket, octal, wafer
73595	Capacitor—Tubular, paper, .0022 mfd., 600 volts (C15)	76368	Spring—Drive cord spring
73789	Capacitor—Tubular, paper, .0068 mfd., 400 volts (C12)	33634	Switch—Radio-phonograph switch (S2)
73561	Capacitor—Tubular, paper, .01 mfd., 400 volts (C17)	74654	Transformer—Output transformer (T3)
73562	Capacitor—Tubular, paper, .022 mfd., 400 volts (C13)	74918	Transformer—First I.F. transformer (T1)
73553	Capacitor—Tubular, paper, .047 mfd., 400 volts (C8, C18)	73037	Transformer—Second I.F. transformer (T2)
73551	Capacitor—Tubular, paper, 0.1 mfd., 400 volts (C6, C19)	33726	Washer—"C" washer for tuning knob shaft
73935	Clip—Mounting clip for I.F. transformer		SPEAKER ASSEMBLIES
74448	Coil—Oscillator coil complete with adjustable core (L2, L3)		92586-5W
35787	Connector—Phono input connector (socket)		RL 105 C13
75474	Connector—Single contact male connector for speaker cable		RMA 274
74133	Control—Volume control and power switch (R10, S1)	75023	Cap—Dust cap
†72953	Cord—Drive cord (approx. 43" overall length required)	75024	Cone—Cone and voice coil
70392	Cord—Power cord and plug	76392	Speaker—8" P.M. speaker complete with cone and voice coil
73693	Grommet—Power cord strain relief (1 set)		NOTE:—If stamping on speaker in instrument does not agree with above speaker numbers, order replacement parts by referring to model number of instrument, number stamped on speaker and full description of part required.
72283	Grommet—Rubber grommet for mounting variable tuning capacitor		MISCELLANEOUS
71116	Lamp—Dial lamp, Mazda #1490	Y2358	Cabinet—Plastic cabinet—maroon—for Model 1X591
76585	Pointer—Station selector pointer	Y2359	Cabinet—Plastic cabinet—ivory—for Model 1X592
72602	Pulley—Drive cord pulley	X3231	Cloth—Grille cloth only
	Resistors—Fixed, composition:	76586	Dial—Polystyrene dial scale
504015	15 ohms, ±20%, 1/2 watt (R16)	76588	Emblem—"RCA Victor" emblem
503082	82 ohms, ±10%, 1/2 watt (R17)	76587	Grille—Speaker grille and cloth assy.
503115	150 ohms, ±10%, 1/2 watt (R14)	74666	Knob—Control knob—maroon—for Model 1X591
513210	1000 ohms, ±10%, 1 watt (R15)	74667	Knob—Control knob—ivory—for Model 1X592
503322	22,000 ohms, ±10%, 1/2 watt (R2)	74734	Spring—Retaining spring for knob
503347	47,000 ohms, ±10%, 1/2 watt (R9)		
503356	56,000 ohms, ±10%, 1/2 watt (R4)		

† Stock No. 72953 is a reel containing 250 feet of cord.

Change in Resistor:

In late production of these receivers the fuse resistor R16 is changed from 15 ohms, 1/2 watt to 33 ohms, 1 watt. The Stock No. of the 33 ohm resistor is 514033.

Change in Parts List:

The Service Data for these models lists only one emblem. The listed emblem (Stock No. 76588) is correct for Model 1X591 only and is maroon color. The correct emblem for Model 1X592 is Stock No. 74782 and is gold finish.

Change in Control Knob:

Late production of these models use control knobs with a dimpled edge.

The stock Nos. of the dimpled knobs are as follows:

- 77234 Knob—Control knob—maroon—for Model 1X591
- 77235 Knob—Control knob—ivory—for Model 1X592

MODELS 1X51, 1X52, 1X53,
1X54, 1X55, 1X56, 1X57, Ch.
RC1104, A, B, -1, A-1, B-1,
C, D, E



1X51 SERIES:

- | | | |
|------------------|-----------------|-----------------|
| 1X51
(Maroon) | 1X52
(Ivory) | 1X53
(Green) |
| 1X54
(Tan) | 1X55
(Blue) | 1X56
(Red) |
| | 1X57
(White) | |

Specifications

Tuning Range540-1600 kc
Intermediate Frequency455 kc
Tube Complement

CHASSIS NO. RC 1104, RC 1104A, RC 1104B

- (1) RCA 12SA7Converter
- (2) RCA 12BA6I.F. Amplifier
- (3) RCA 12SQ7Det.—A.V.C.—A.F. Amp.
- (4) RCA 50L6GTOutput
- (5) RCA 35Z5GTRectifier

CHASSIS NO. RC 1104-1, RC 1104A-1, RC 1104B-1

Same as above except rectifier is RCA 35W4 instead of RCA 35Z5GT.

CHASSIS NO. RC 1104C, RC 1104D, RC 1104E

- (1) RCA 12BE6Converter
- (2) RCA 12BA6I.F. Amplifier
- (3) RCA 12AV6Det.—A.V.C.—A.F. Amp.
- (4) RCA 50C5Output
- (5) RCA 35W4Rectifier

Dial LampType 47, 6-8 volts, 0.15 amp.

Chassis Identification

Model No.	1X51	1X52 1X57	1X53, 1X54 1X55, 1X56
Chassis No.	RC 1104 RC 1104-1 RC 1104C	RC 1104A RC 1104A-1 RC 1104D	RC 1104B RC 1104B-1 RC 1104E

Power Supply Rating

115 volts, AC, 50 or 60 cycles, or DC30 watts

Loudspeaker

Size and Type4-inch PM
V.C. Impedance3.2 ohms at 400 cycles

Power Output

Undistorted1.1 watts
Maximum1.4 watts

Dimensions (Overall)

Height.....7⁵/₈" Width.....11⁹/₁₆" Depth.....6³/₄"

Weight6 lbs. net

Dial Centering

If the mounting of the tuning condenser has been disturbed, it may be necessary to adjust its position after replacing the chassis in the cabinet. This may be done in the following manner:

1. Replace tuning knob.
2. Install chassis and tighten the mounting screws.
3. Loosen the two screws which hold the tuning condenser mounting bracket to the chassis.
4. Adjust the position of the tuning condenser mounting bracket so that the tuning knob may be rotated without binding on the cabinet.
5. The two screws should then be tightened to maintain this position.

Power Supply Polarity

For operation on d-c, the power plug must be inserted in the outlet for correct polarity. If the set does not function, reverse the plug. On a-c, reversal of the plug may reduce hum.

Replacement of Dial Lamp

To replace the dial lamp the back cover must be removed. It is secured to the cabinet with four spring clips. Use care to avoid breaking the lead wires from the back cover to the chassis. The dial lamp socket is located at the upper left corner of the speaker and may be removed by pulling diagonally up and to the right.

If higher than normal line voltage causes repeated burning out of the dial light, it may be replaced with a type #44 lamp instead of the specified type #47. Type #44 will provide less illumination than type #47, but it will last longer.

MODELS 1X51 Series, Ch. RC1104, A, B, -1, A-1, B-1, C, D, E

Alignment Procedure

Critical Lead Dress

1. Dress all capacitors down against chassis. Connect outside foil of all capacitors as indicated in schematic diagram.
2. Locate C-10 in its mounting clip so that it butts against end of chassis.
3. Dress all circuit wiring against chassis.
4. Dress R-11 away from R-4.
5. Dress junction of R-2 and C-2 to prevent short circuits to chassis and dial back plate.

Test-Oscillator

For all alignment operations, connect the low side of the test-oscillator to the receiver chassis, and keep the oscillator output as low as possible to avoid a-v-c action.

On AC operation an isolation transformer (115 v./115 v.) may be necessary for the receiver if the test oscillator is also AC operated.

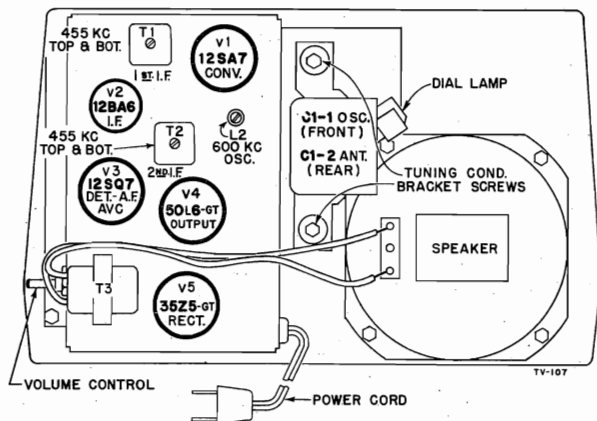

Steps	Connect the high side of test-oscillator to—	Tune test-osc. to—	Turn radio dial to—	Adjust the following for max. output
1	12BA6 I-F grid through .01 mfd. capacitor	455 kc	Quiet-point 1600 kc. end of dial	*T2 (top and bottom) 2nd I-F trans.
2	Stator of C1-2 through .01 mfd.			T1 (top and bottom) 1st I-F trans.
3		1620 kc	Extreme clockwise (plates fully open)	osc. trimmer
4	Short wire placed near loop to radiate signal	1400 kc	1400 kc signal	ant. trimmer
5		600 kc	600 kc signal	L2 (osc.) Rock gang
6	Repeat steps 3, 4 and 5.			

* Do not readjust T2 when test oscillator is connected to C1-2.

† When adjusting ant. trimmer it is necessary to have the loop in the same position and spacing as it will have when assembled in the cabinet. This spacing is approximately 5½" from dial back plate to loop.

Tube and Trimmer Locations

Chassis No. RC 1104, RC 1104A, RC 1104B

For Chassis No. RC 1104-1, RC 1104A-1 and RC-1104B-1 the rectifier tube is type 35W4 instead of 35Z5GT.

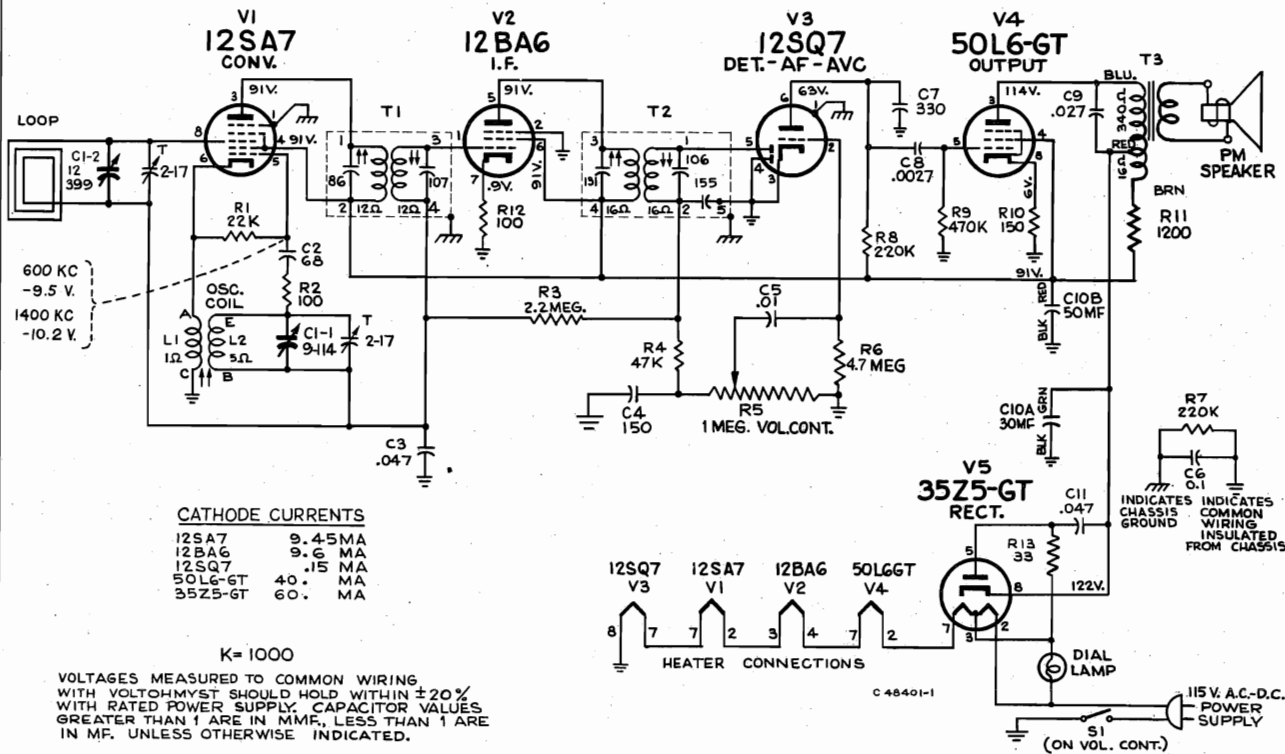

CHASSIS NO. RC 1104, RC 1104A, RC 1104B

Schematic Circuit Diagram

For Chassis No. RC 1104-1, RC 1104A-1 and RC-1104B-1 the rectifier tube is type 35W4 instead of 35Z5GT.

MODELS 1X51 Series, Ch. RC1104, A, B, -1, A-1, B-1, C, D, E

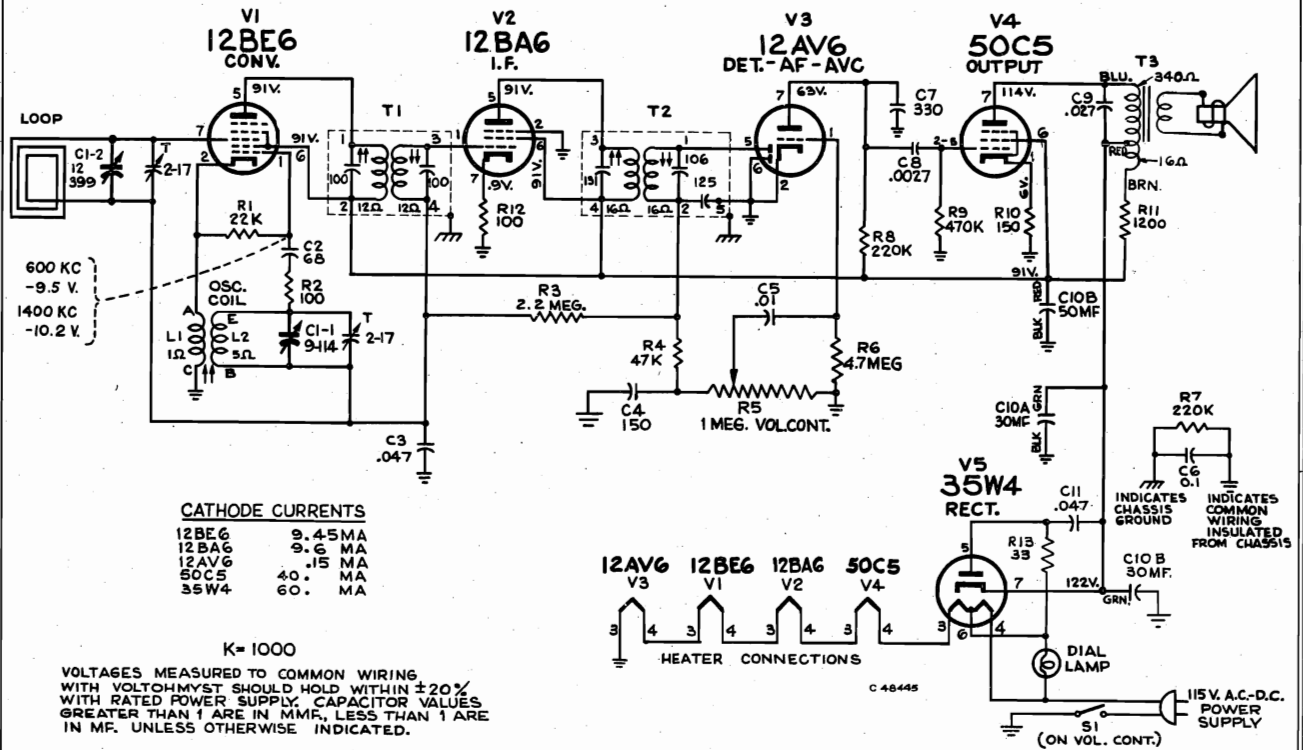

Schematic Circuit Diagram

CHASSIS NO. RC 1104C, RC 1104D, RC 1104E

Production Changes

In early production RC 1104, RC 1104A and RC 1104B:

- R3 was 3.3 megohm (now 2.2 meg.).
- R6 was 10 megohm (now 4.7 meg.).
- R13 was omitted (plate circuit of rectifier tube).

A few 1st I.F. transformers (T1) were used which had an incorrect primary capacitor. To permit the use of these transformers, two 5 mmf. ceramic capacitors were added across the primary (Term. #1 to Term. #2).

In early production RC 1104-1, RC 1104A-1, and RC 1104B-1:

- R13 was omitted (plate circuit of rectifier tube).

Change in Power Cord Location:

To facilitate wiring, the power cord in late production of these receivers has been changed to enter the chassis at the outer lower corner instead of the corner close to the speaker.

Change in Volume Control Knob:

The original volume control knob had a smooth outer edge. The knob used in late production has a dimpled edge. The Stock Nos. of the new knobs are listed below.

- 77140 Knob—Volume control knob—maroon—Model 1X51
- 77235 Knob—Volume control knob—ivory —Model 1X52
- 77237 Knob—Volume control knob—green —Model 1X53
- 77238 Knob—Volume control knob—tan —Model 1X54
- 77239 Knob—Volume control knob—blue —Model 1X55
- 77240 Knob—Volume control knob—red —Model 1X56
- 77236 Knob—Volume control knob—white —Model 1X57

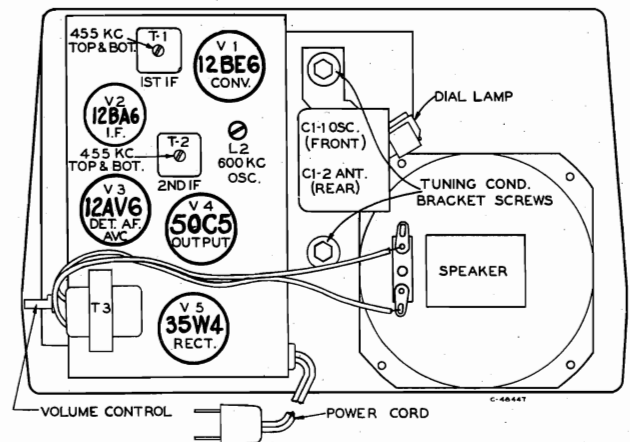

Tube and Trimmer Locations
Chassis No. RC 1104C, RC 1104D, RC 1104E

MODELS 1X51 Series, Ch. RC1104

A, B, -1, A-1, B-1, C, D, E

Stock No.	DESCRIPTION	Stock No.	DESCRIPTION
CHASSIS ASSEMBLIES			
	RC 1104, RC 1104-1, RC 1104C Model 1X51 RC 1104A, RC 1104A-1, RC 1104D Models 1X52, 1X57 RC 1104B, RC 1104B-1, RC 1104E Models 1X53, 1X54, 1X55, 1X56	74734	Spring—Spring clip for tuning control knob
76712	Antenna—Antenna loop and back cover for Models 1X51, 1X53, 1X54, 1X55 and 1X56	54414	Socket—Tube socket, octal, moulded, saddle-mounted for 12SA7 and 12SQ7 tubes
76730	Antenna—Antenna loop and back cover for Models 1X52 and 1X57	70827	Socket—Tube socket, octal, wafer for 35Z5GT and 50L6GT tubes
76715	Capacitor—Variable tuning capacitor (C1-1, C1-2)	76714	Transformer—Output transformer (T3)
39624	Capacitor—Mica, 68 mmf. (C2)	75486	Transformer—First I.F. transformer (T1)
39632	Capacitor—Mica, 150 mmf. (C4)	75487	Transformer—Second I.F. transformer (T2)
72571	Capacitor—Mica, 330 mmf. (C7)	SPEAKER ASSEMBLIES	
76718	Capacitor—Electrolytic comprising 1 section of 50 mfd., 150 volts and 1 section of 30 mfd., 150 volts (C10A, C10B)	971495-1	
73599	Capacitor—Tubular, paper, .0027 mfd., 600 volts (C8)	76391	Speaker—4" P.M. speaker complete with cone and voice coil
73561	Capacitor—Tubular, paper, .01 mfd., 400 volts (C5)	MISCELLANEOUS	
73554	Capacitor—Tubular, paper, .027 mfd., 400 volts (C9)	Y2379	Cabinet—BLUE plastic cabinet less "RCA Victor" emblem for Model 1X55
73553	Capacitor—Tubular, paper, .047 mfd., 400 volts (C3, C11)	Y2377	Cabinet—GREEN plastic cabinet less "RCA Victor" emblem for Model 1X53
73551	Capacitor—Tubular, paper, oil impregnated, 0.1 mfd., 400 volts (C6)	Y2375	Cabinet—IVORY plastic cabinet less "RCA Victor" emblem for Model 1X52
73935	Clip—Mounting clip for I.F. transformer	Y2373	Cabinet—MAROON plastic cabinet less "RCA Victor" emblem for Model 1X51
74448	Coil—Oscillator coil complete with adjustable core (L1, L2)	Y2380	Cabinet—RED plastic cabinet less "RCA Victor" emblem for Model 1X56
74285	Control—Volume control and power switch (R5, S1)	Y2378	Cabinet—TAN plastic cabinet less "RCA Victor" emblem for Model 1X54
70392	Cord—Power cord and plug	Y2376	Cabinet—WHITE plastic cabinet less "RCA Victor" emblem for Model 1X57
74838	Grommet—Power cord strain relief (1 set)	76798	Clip—Speed clip for dial back plate (lower) (2 req'd) for Models 1X51, 1X53, 1X54, 1X55, 1X56
72283	Grommet—Rubber grommet for mounting variable capacitor	76799	Clip—Speed clip for dial back plate (lower) (2 req'd) for Models 1X52, 1X57
76713	Knob—Tuning control knob	76797	Clip—Speed clip for dial back plate (upper) (2 req'd)
31480	Lamp—Dial lamp—Mazda #47	73494	Clip—Spring clip to fasten antenna and back assembly to cabinet (4 req'd)
	Resistors—Fixed, composition:—	76720	Dial—Polystyrene dial scale
514033	33 ohms, ±20%, 1 watt (R13)	74782	Emblem—"RCA Victor" emblem
504110	110 ohms, ±20%, ½ watt (R2, R12)	76760	Knob—Volume control knob—BLUE—for Model 1X55
503115	150 ohms, ±10%, ½ watt (R10)	76758	Knob—Volume control knob—GREEN—for Model 1X53
513212	1200 ohms, ±10%, 1 watt (R11)	74667	Knob—Volume control knob—IVORY—for Model 1X52
504322	22,000 ohms, ±20%, ½ watt (R1)	76719	Knob—Volume control knob—MAROON—for Model 1X51
504347	47,000 ohms, ±20%, ½ watt (R4)	76761	Knob—Volume control knob—RED—for Model 1X56
504422	220,000 ohms, ±20%, ½ watt (R7, R8)	76759	Knob—Volume control knob—TAN—for Model 1X54
504447	470,000 ohms, ±20%, ½ watt (R9)	74007	Knob—Volume control knob—WHITE—for Model 1X57
504522	2.2 megohm, ±20%, ½ watt (R3)	76721	Ring—Decorative ring for tuning knob (fastens to cabinet)
504547	4.7 megohm, ±20%, ½ watt (R6)	74734	Spring—Spring clip for volume control knob
76802	Shield—Dial lamp shield for Models 1X52, 1X53, 1X54, 1X55, 1X56 and 1X57		
73584	Shield—Tube shield for 12AV6 tube		
76723	Socket—Dial lamp socket complete with leads		
76716	Socket—Tube socket, 7 pin miniature, wafer with center shield for 12BE6, 12BA6 and 12AV6 tubes		
74822	Socket—Tube socket, 7 pin miniature, wafer less center shield for 50C5 and 35W4 tubes		

APPLY TO YOUR RCA DISTRIBUTOR FOR PRICES ON REPLACEMENT PARTS

MODELS 2B400, 2B401,
2B402, 2B403, 2B404,
2B405, Ch. RC1114



2 B 400 SERIES

2 B 400 <i>Grey</i>	2 B 401 <i>Black</i>	2 B 402 <i>Ivory</i>
2 B 403 <i>Green</i>	2 B 404 <i>Tan</i>	2 B 405 <i>Red</i>

Specifications

Tuning Range540-1600 kc
 Intermediate Frequency455 kc
 Tube Complement:
 1. RCA 1R5Converter
 2. RCA 1U4I.F. Amplifier
 3. RCA 1U5Det. A.F.Amp. A.V.C.
 4. RCA 3V4Output
 Loudspeaker
 Size and type2" x 3" P.M.
 Voice coil impedance11¼ ohms at 1000 cycles
 Weight (with batteries)approx. 3¾ lbs.

Batteries Required:
 Type of Battery

	Current Drain	
	Normal Pos.	Saver Pos.
"A"—1.5 volt (two) RCA VS 236	0.25 amp.	0.20 amp.
"B"—67.5 volts RCA VS 216	8.45 ma.	5.45 ma.

Battery life is approximately 100 hrs. intermittent service with battery-saver switch in "Normal" position. With switch in "Saver" position, battery life is increased approximately 30%.

Power Output:

Undistorted075 watt
Maximum	0.10 watt
Dimensions (over-all)	approx. 8¾" x 5½" x 2 ¹¹ / ₁₆ "

Case Back

To remove—insert small coin in the slot at top rear of case and pry open.

To replace—insert bottom edge into case and snap top edge in place.

Off-On Indicator

A window in the case (just below edge of volume control knob) indicates whether set is turned ON or OFF. "ON" appears in window when set is turned ON and disappears when set is turned OFF.

Battery-Life Saver Switch

Maximum power is obtained when the slider button is pushed toward left (outer edge of case). Extra battery life with slight effect on performance is obtained with the slider button pushed to the right (toward center of case).

Battery Life

The life of the "A" and "B" batteries is approximately equal. For best performance all batteries should be replaced at the same time.

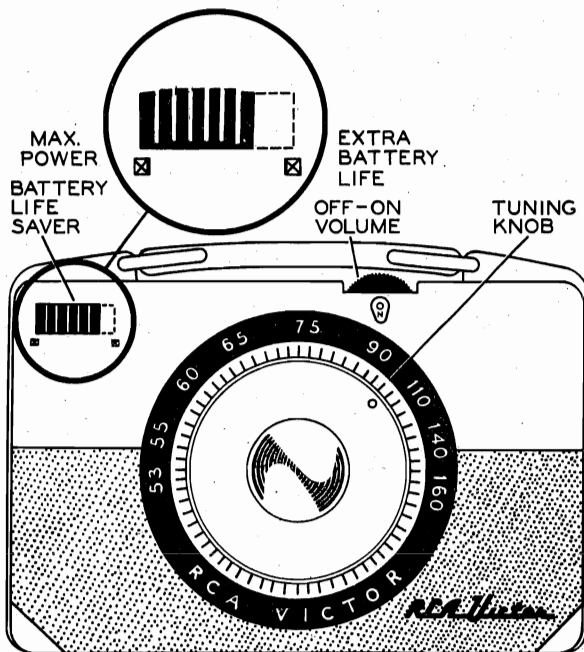

Controls

MODELS 2B400, 2B401, 2B402, 2B403, 2B404, 2B405, Ch. RC1114

Output Meter.—Connect meter to voice coil terminals. Turn volume control to maximum position.

Test-Oscillator.—For all alignment operations, connect the low side of the test-oscillator to the receiver chassis, and keep the oscillator output as low as possible to avoid a-v-c action.

Note:—The ant. coil is supplied pre-adjusted and cemented to rod. This makes further adjustment unnecessary. However when replacing ant. assembly make certain that the coil end of the rod is fully entered in its rubber mounting grommet but does not extend through the grommet more than is required to permit the opposite end to fit inside the case.

Replacement of Component Parts

I. To Remove Back Cover

- a. Depress top of case midway between the handle supports, until the top end of the back separates from the main case.
- b. Pull the back cover back and up, thereby unhooking the retaining lugs in the bottom of the main case.

II. To Replace Batteries

- a. Remove back cover.
- b. Remove both "A" and "B" batteries. The "B" battery snap fasteners can best be removed by inserting a screwdriver under the snap fastener strip and prying upward.
- c. The "A" batteries can easily be removed by pulling up on the spring wire clips.

Note: The "A" and "B" batteries have approximately equal life and therefore it is advisable to replace all batteries at one time.

III. To Remove Chassis

- a. Remove dial knob by grasping with finger tips at two sides and pulling.
- b. Remove back cover.
- c. Remove batteries.
- d. Remove "A+" contacts by squeezing against case and sliding out of slots in case.
- e. Remove the four screws "A."
- f. Grasp the assembly by the speaker and pull the bottom end down and outward to clear the volume control knob.

IV. To Replace Chassis

- a. Observe the position of the battery save button extension in relation to the "battery-save" switch. This extension must engage with the center of the battery save switch.
- b. Replace in reverse order to that given for chassis removal.

V. To Remove Handle

- a. Spread the square spring wire clips by pulling on one side of a clip.
- b. Allow the clip to return to its original shape but resting on the outside of the case.
- c. Pull the other side of the clip out of the case.

VI. To Replace Battery Save Switch Button

- a. Remove chassis.
- b. Spread the open end of the spring clip retainer no more than necessary to permit removal of clip.
- c. Slide the clip clear of the slider button.
- d. Turn slider button one-quarter turn and pull out of case.
- e. Replace button in reverse order—do not use excessive force in replacing spring clip.

Steps	Connect high side of test osc. to—	Tune test-osc. to—	Turn radio dial to—	Adjust the following for max. output—
1				Trimmers of 2nd I-F trans
2	High side of ant. coil (terminal lug on coil which is connected to Pin #6 of 1R5 tube)	455 kc	Quiet point near 1600 kc	Trimmers of 1st I-F trans.
3	Repeat steps 1 and 2			
4		1400 kc	14 Rock gang	C1-1T (osc.)
5	Short wire placed near ant. coil for radiated signal	600 kc	60 Rock gang	L2 (osc.)
6	Repeat steps 4 and 5			

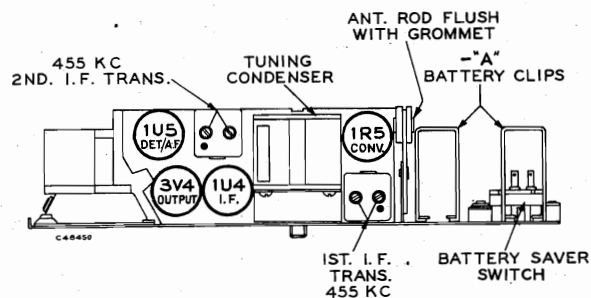
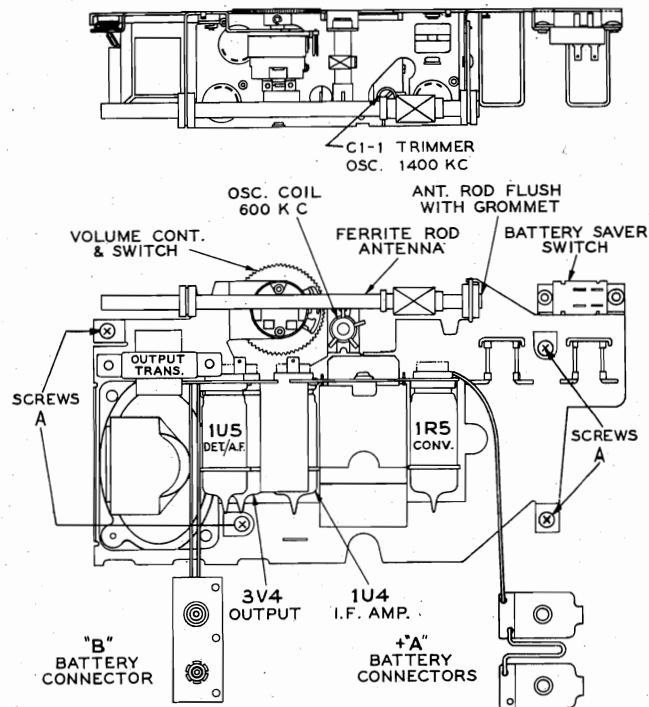

Tube and Trimmer Locations

MODELS 2B400, 2B401, 2B402,
2B403, 2B404, 2B405, Ch. RC1114

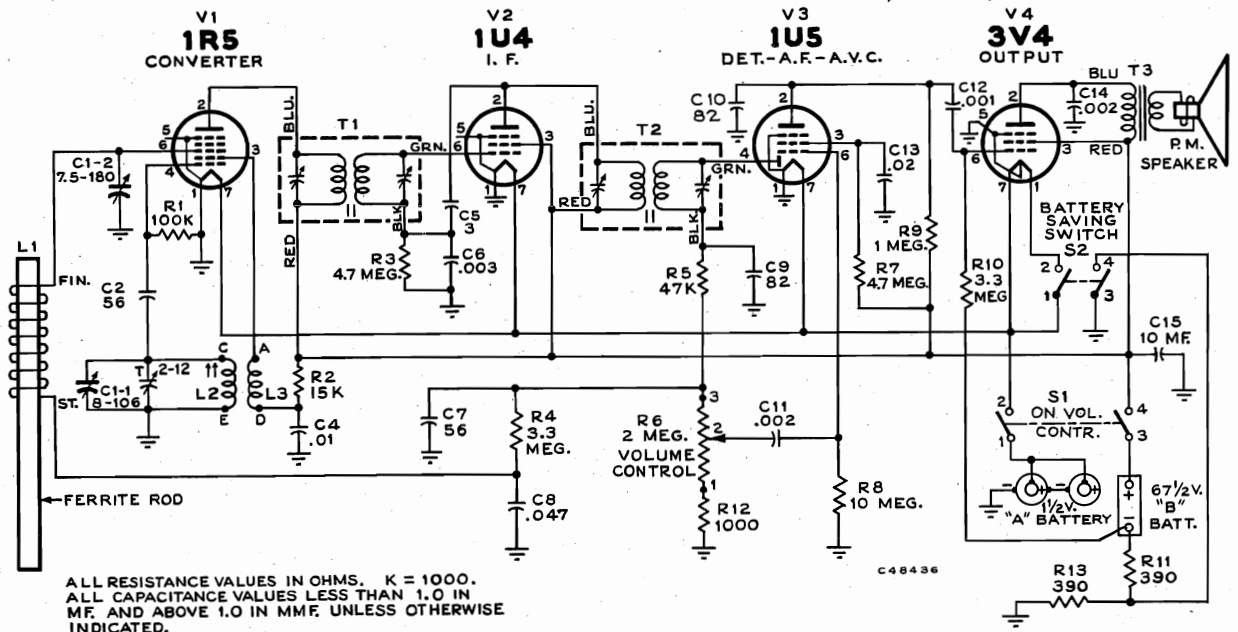

Schematic Diagram

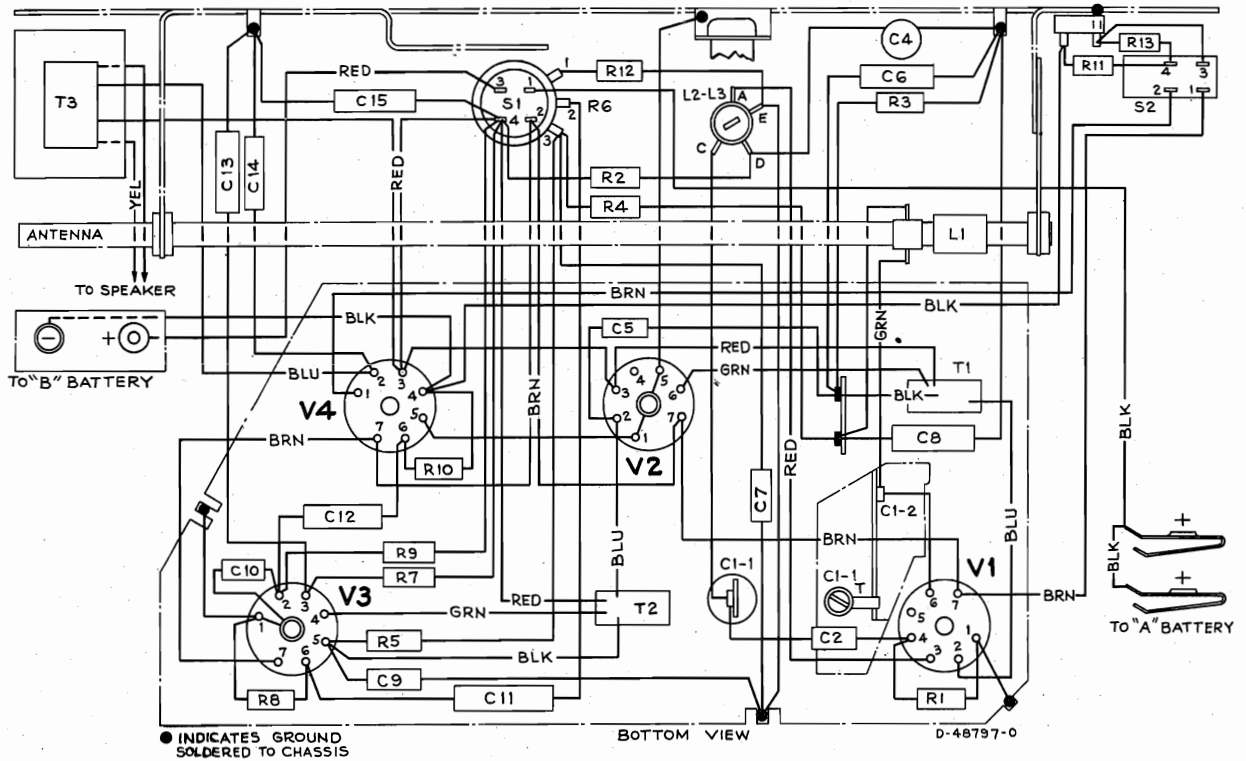

Connection Diagram

CRITICAL LEAD DRESS

1. Position Ferrite antenna rod as described above.
2. Dress all bus wires, pigtail leads and non-insulated components away from chassis base and away from each other.
3. Dress neutralizing capacitor C5 against front of chassis and with clearance under volume control knob. Utilize shielding effect of oscillator coil mounting bracket.
4. Dress all I-F transformer leads down to base.

MODELS 2B400, 2B401, 2B402, 2B403, 2B404, 2B405, Ch. RC1114

Incorrect Tube Location Label:

A few receivers were shipped with an incorrect tube location label in which the designation of 3V4 and 1U5 tubes were transposed. These may be readily identified by the label color. The incorrect label is BLUE, the correct label is YELLOW. The correct tube locations are illustrated below.

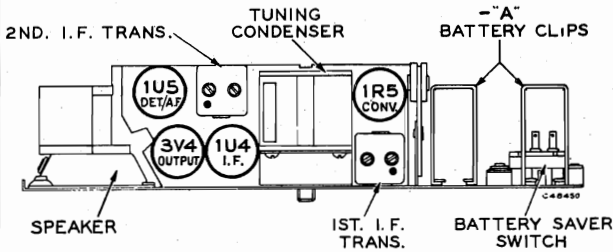

"A" Battery Lead:

A rubber band is used for the purpose of holding the "A" battery lead in a position where it will not be accidentally torn loose when replacing the battery. When servicing one of these receivers, make sure that this rubber band is around the i-f transformer shield can and holding the "A" battery lead against the chassis.

Correct Tonal Response:

For correct tonal response it is necessary that the holes in the case, where the metal grille is attached, be closed. This is done at the factory by covering the tabs, on the inside of the case, with tape. Absence of this tape will adversely affect the tonal response of these receivers.

Correction to Parts List:

The Stock No. of the GREY case assembly for Model 2B400 is incorrectly listed as 76860. The correct Stock No. is 76838.

STOCK No.	DESCRIPTION	STOCK No.	DESCRIPTION
	CHASSIS ASSEMBLIES RC. 1114	77163	Back—Case back—RED—for Model 2B405
76847	Antenna—Ferrite rod antenna (L1)	76859	Button—Battery saver switch slider button—GREY—for Model 2B400
76846	Capacitor—Variable tuning capacitor (C1-1, C1-2)	77164	Button—Battery saver switch slider button—BLACK—and spring clip for Model 2B401
57090	Capacitor—Ceramic, 3 mmf. (C5)	77165	Button—Battery saver switch slider button—IVORY—and spring clip for Model 2B402
75784	Capacitor—Ceramic, 56 mmf. (C2, C7)	77166	Button—Battery saver switch slider button—GREEN—and spring clip for Model 2B403
75785	Capacitor—Ceramic, 82 mmf. (C9, C10)	77167	Button—Battery saver switch slider button—TAN—and spring clip for Model 2B404
73960	Capacitor—Ceramic, 10,000 mmf. (C4)	77168	Button—Battery saver switch slider button—RED—and spring slip for Model 2B405
73964	Capacitor—Electrolytic, 10 mfd., 70 volts (C15)	76860	Case—Case assembly—GREY—less handle, links and back for Model 2B400
72792	Capacitor—Tubular, paper, .001 mfd., 200 volts (C12)	77154	Case—Case assembly—BLACK—less handle, links and back for Model 2B401
73750	Capacitor—Tubular, paper, .002 mfd., 200 volts (C11, C14)	77155	Case—Case assembly—IVORY—less handle, links and back for Model 2B402
73961	Capacitor—Tubular, paper, .003 mfd., 200 volts (C6)	77156	Case—Case assembly—GREEN—less handle, links and back for Model 2B403
71928	Capacitor—Tubular, paper, .02 mfd., 200 volts (C13)	77157	Case—Case assembly—TAN—less handle, links and back for Model 2B404
73558	Capacitor—Tubular, paper, .047 mfd., 200 volts (C8)	77158	Case—Case assembly—RED—less handle, links and back for Model 2B405
76852	Clip—"A" battery mounting clip (formed spring wire) (2 required)	76860	Clip—Retaining spring clip for battery saver switch slider button
75010	Clip—"C" clip and screw to mount output transformer	76842	Dial—Polystyrene dial scale—GREY—for Model 2B400
75774	Coil—Oscillator coil complete with adjustable core (L2, L3)	77169	Dial—Polystyrene dial scale—BLACK—for Model 2B401
76854	Contact—"A" battery contact (2 required)	77170	Dial—Polystyrene dial scale—IVORY—for Model 2B402
75773	Control—Volume control and power switch (R6, S1)	77171	Dial—Polystyrene dial scale—GREEN—for Model 2B403
73796	Grommet—Rubber grommet for antenna rod (2 required)	77172	Dial—Polystyrene dial scale—TAN—for Model 2B404
76853	Insulator—Bakelite insulator for ferrite rod antenna	77173	Dial—Polystyrene dial scale—RED—for Model 2B405
76851	Knob—Volume control and power switch knob—less set screw	75844	Emblem—"RCA Victor" emblem
76855	Lead—"B" battery lead complete with connector	73843	Grille—Metal grille—perforated—GREY—for Model 2B400
503139	Resistor—Fixed, composition:—	77179	Grille—Metal grille—perforated—GOLD—for Models 2B401 and 2B402
504210	390 ohms, ±10%, 1/2 watt (R11, R13)	77180	Grille—Metal grille—perforated—GREEN—for Model 2B403
503315	1000 ohms, ±20%, 1/2 watt (R12)	77181	Grille—Metal grille—perforated—TAN—for Model 2B404
503315	15,000 ohms, ±10%, 1/2 watt (R2)	77182	Grille—Metal grille—perforated—RED—for Model 2B405
504347	47,000 ohms, ±20%, 1/2 watt (R5)	73839	Handle—Carrying handle—BLACK—for Models 2B400 and 2B401
504410	470,000 ohms, ±20%, 1/2 watt (R1)	77183	Handle—Carrying handle—BEIGE—for Model 2B402
504510	1 megohm, ±20%, 1/2 watt (R9)	77184	Handle—Carrying handle—GREEN—for Model 2B403
504533	3.3 megohm, ±20%, 1/2 watt (R4, R10)	77185	Handle—Carrying handle—BROWN—for Model 2B404
504547	4.7 megohm, ±20%, 1/2 watt (R3, R7)	77186	Handle—Carrying handle—RED—for Model 2B405
504610	10 megohm, ±20%, 1/2 watt (R8)	76856	Knob—Tuning control knob—GREY—for Model 2B400
70527	Screw—#6-32, x 3/16" socket head set screw for volume control knob	77174	Knob—Tuning control knob—BLACK—for Model 2B401
75780	Socket—Tube socket, 7 pin, miniature, saddle mounted	77175	Knob—Tuning control knob—IVORY—for Model 2B402
76848	Switch—Battery saver switch (S2)	77176	Knob—Tuning control knob—GREEN—for Model 2B403
76849	Transformer—First I.F. transformer (T1)	77177	Knob—Tuning control knob—TAN—for Model 2B404
76850	Transformer—Second I.F. transformer (T2)	77178	Knob—Tuning control knob—RED—for Model 2B405
75777	Transformer—Output transformer (T3)	73840	Link—Carrying handle link (2 req'd)
	SPEAKER ASSEMBLY 92523-W	73858	Ring—Bearing ring for tuning knob
76373	Speaker—2" x 3" P.M. speaker complete with cone and voice coil	7C857	Screw—#4-40 x 3/32" cross recessed binder head machine screw for mounting chassis (4 req'd)
	MISCELLANEOUS	74734	Spring—Spring clip for tuning control knob
76841	Back—Case back—GREY—for Model 2B400		
77159	Back—Case back—BLACK—for Model 2B401		
77160	Back—Case back—IVORY—for Model 2B402		
77161	Back—Case back—GREEN—for Model 2B403		
77162	Back—Case back—TAN—for Model 2B404		

APPLY TO YOUR RCA DISTRIBUTOR FOR PRICES OF REPLACEMENT PARTS

MODELS 2X61, 2X62, Ch.
RC1080C, RC1080D

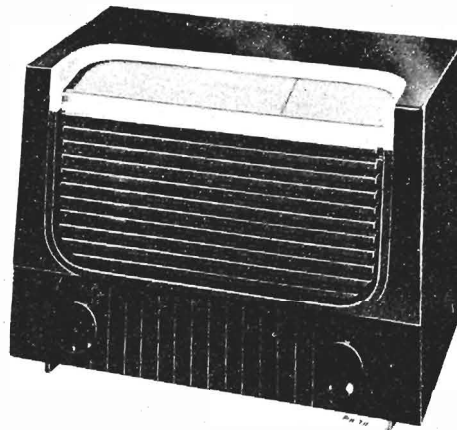

Model 2X61 Maroon Model 2X62 Ivory

SPECIFICATIONS

Tuning Range 540—1600 kc
 Intermediate Frequency 455 kc
 Tube Complement
 (1) RCA 12SK7 R.F. Amplifier
 (2) RCA 12SA7 Converter
 (3) RCA 12SK7 I.F. Amplifier
 (4) RCA 12SQ7 Det.-A.V.C.-A.F. Amp.
 (5) RCA 35L6GT Output
 (6) RCA 35Z5GT Rectifier
 Power Supply Rating
 115 volts d. c. or 50 to 60 cycles a. c. 35 watts

Dial Lamp 2 Mazda type 1490, 3.2 volts, 0.15 amp.
 Loudspeaker
 Size and type 4-in. P.M.
 Voice coil impedance 3.2 ohms at 400 cycles
 Power Output
 Undistorted 0.85 watt
 Maximum 1.15 watts
 Tuning Drive Ratio 8.5 to 1 (4¼ turns of knob)
 Weight 8 lbs.
 Cabinet Dimensions
 Height 8%” Width 11¼” Depth 7½”

STOCK No.	DESCRIPTION	STOCK No.	DESCRIPTION
CHASSIS ASSEMBLIES			
	RC 1080C—Model 2X61 RC 1080D—Model 2X62	503112	120 ohms, ±10%, ½ watt, R4, R11
77143	Antenna—Antenna loop and back cover assembly—maroon—for Model 2X61	503118	180 ohms, ±10%, ½ watt, R1
77144	Antenna—Antenna loop and back cover assembly—ivory—for Model 2X62	503127	270 ohms, ±10%, ½ watt, R15
77143	Back—Cabinet back cover and antenna loop assembly—maroon—for Model 2X61	513212	1200 ohms, ±10%, 1 watt, R12
77144	Back—Cabinet back cover and antenna loop assembly—ivory—for Model 2X62	503312	12,000 ohms, ±10%, ½ watt, R2
77145	Capacitor—Variable tuning capacitor complete with drive drum, C1, C2, C3, C4, C5, C6	503322	22,000 ohms, ±10%, ½ watt, R3
39042	Capacitor—Ceramic, 47 mmf., C8	503356	56,000 ohms, ±10%, ½ watt, R7
71924	Capacitor—Ceramic, 56 mmf., C9	503410	100,000 ohms, ±10%, ½ watt, R16
73501	Capacitor—Ceramic, 150 mmf., C12, C13	503422	220,000 ohms, ±10%, ½ watt, R5, R6
73473	Capacitor—Ceramic, 4700 mmf., C20	503447	470,000 ohms, ±10%, ½ watt, R10
74662	Capacitor—Electrolytic comprising 1 section of 80 mfd., 150 volts and 1 section of 50 mfd., 150 volts, C19A, C19B	503522	2.2 megohm, ±10%, ½ watt, R8
73595	Capacitor—Tubular, paper, .0022 mfd., 600 volts, C14	503547	4.7 megohm, ±10%, ½ watt, R9
73797	Capacitor—Tubular, paper, .015 mfd., 600 volts, C16	74691	Shaft—Tuning knob shaft
73562	Capacitor—Tubular, paper, .022 mfd., 400 volts, C15	74697	Socket—Dial lamp socket
73553	Capacitor—Tubular, paper, .047 mfd., 400 volts, C17, C18	54414	Socket—Tube socket
73551	Capacitor—Tubular, paper, 0.1 mfd., 400 volts, C10, C11	76368	Spring—Drive cord spring
73794	Capacitor—Tubular, paper, 0.22 mfd., 400 volts, C21	33634	Switch—“Radio-Phono” switch, S2
73935	Clip—Mounting clip for I.F. transformer	73036	Transformer—First I.F. transformer complete with adjustable cores, T1
74693	Coil—Oscillator coil complete with adjustable cores, L3, L4	73037	Transformer—Second I.F. transformer complete with adjustable cores, T2
73677	Coil—R.F. coil complete with adjustable cores, L1, L2	73976	Transformer—Output transformer, T3
35787	Connector—Phono input connector	35969	Washer—“C” washer for tuning knob shaft
75474	Connector—Single contact male connector for output transformer leads (2 req'd)		SPEAKER ASSEMBLIES
38410	Control—Volume control and power switch, R14, S1		971495-3
72953	Cord—Drive cord (approx. 50" overall)	76391	Speaker—4" P.M. speaker complete with cone and voice coil (3.2 ohms)
70392	Cord—Power cord and plug		MISCELLANEOUS
73693	Grommet—Power cord strain relief (1 set)	Y2445	Cabinet—Plastic cabinet—maroon—complete with dial escutcheon for Model 2X61
72283	Grommet—Rubber grommet for mounting tuning capacitor	Y2446	Cabinet—Plastic cabinet—ivory—complete with dial escutcheon for Model 2X62
77142	Pointer—Station selector pointer	77146	Dial—Polystyrene dial scale
72602	Pulley—Drive cord pulley	77241	Escutcheon—Dial escutcheon
514033	Resistor—Fixed, composition:—33 ohms, ±20%, 1 watt, R13	74931	Knob—Control knob—maroon—for Model 2X61
		72645	Knob—Control knob—ivory—for Model 2X62
		71116	Lamp—Dial lamp—Mazda 1490
		74301	Screw—#8 x ¾" binder head screw (cross recessed) for mounting dial
		30900	Spring—Retaining spring for knobs

† Stock No. 72953 is a reel containing 250 feet of cord.

APPLY TO YOUR RCA DISTRIBUTOR FOR PRICES OF REPLACEMENT PARTS

MODELS 2X61, 2X62, Ch. RC1080C, RC1080D

NOTE.—If reception is not obtained on d. c. operation, reverse plug in outlet receptacle. On a. c. operation this may reduce hum.

The position of the speaker is adjustable; the correct position is indicated on the illustration "Tube and Trimmer Locations."

ALIGNMENT PROCEDURE

Cathode Ray Alignment is the preferable method. Connections for the oscilloscope are shown on the schematic diagram.

Output Meter Alignment.—If this method is used, connect the meter across the voice coil and turn the receiver volume control to maximum.

Test Oscillator.—Connect low side of test oscillator to common wiring in series with a .1 mf. capacitor. If the test oscillator is a. c. operated it may be necessary to use an isolation transformer for the receiver during alignment and the low side of the test oscillator connected directly to common wiring at the electrolytic capacitor. Keep the oscillator output low to prevent a-v-c action.

Correction to Alignment Procedure:

The oscillator trimmer C6 should be adjusted at 1620 kc as stated in the Service Data, but the r.f. trimmer (C5) and the antenna trimmer (C4) should be adjusted for maximum when the receiver is tuned to a 1400 kc signal.

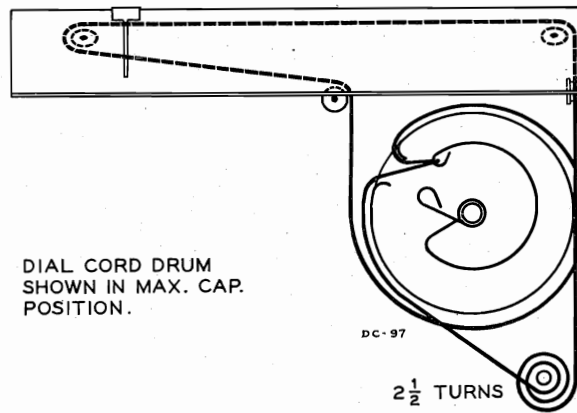

DIAL CORD DRUM SHOWN IN MAX. CAP. POSITION.

2 1/2 TURNS

Dial Indicator and Drive Mechanism

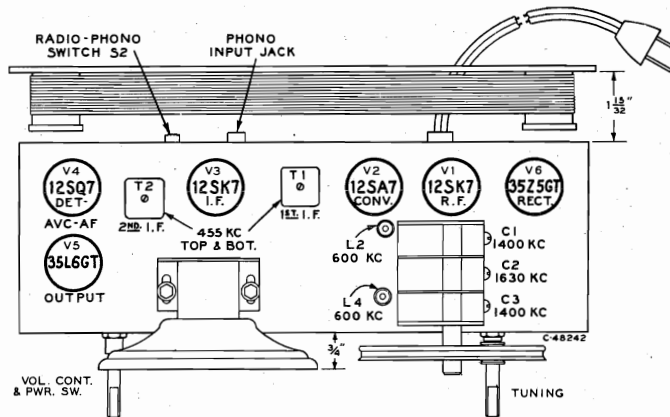

Step	Connect high side of sig. gen. to—	Sig. gen. output	Turn radio dial to—	Adjust for peak output
1	Pin No. 4 of 12SK7 tube	455 kc	Quiet point near 600 kc	Top and bottom cores of T2
2	Pin No. 8 of 12SA7 tube			Top and bottom cores of T1
3		1620 kc	1620 kc	C6 Osc. C5 R.F. C4 Ant.
4	"External Antenna" terminal through 100 mmf. capacitor	Shunt C5 with 22,000 ohm resistor		L4 Osc. (Rock gang)
		600 kc	600 kc	
5		Remove 22,000 ohm resistor from C5		L2 R.F.
		600 kc	600 kc	
6		Repeat steps 3, 4 and 5		

The position of the loop antenna in relation to the chassis affects adjustment of C4. The correct position is indicated on the illustration "Tube and Trimmer Locations."

Tube and Trimmer Locations

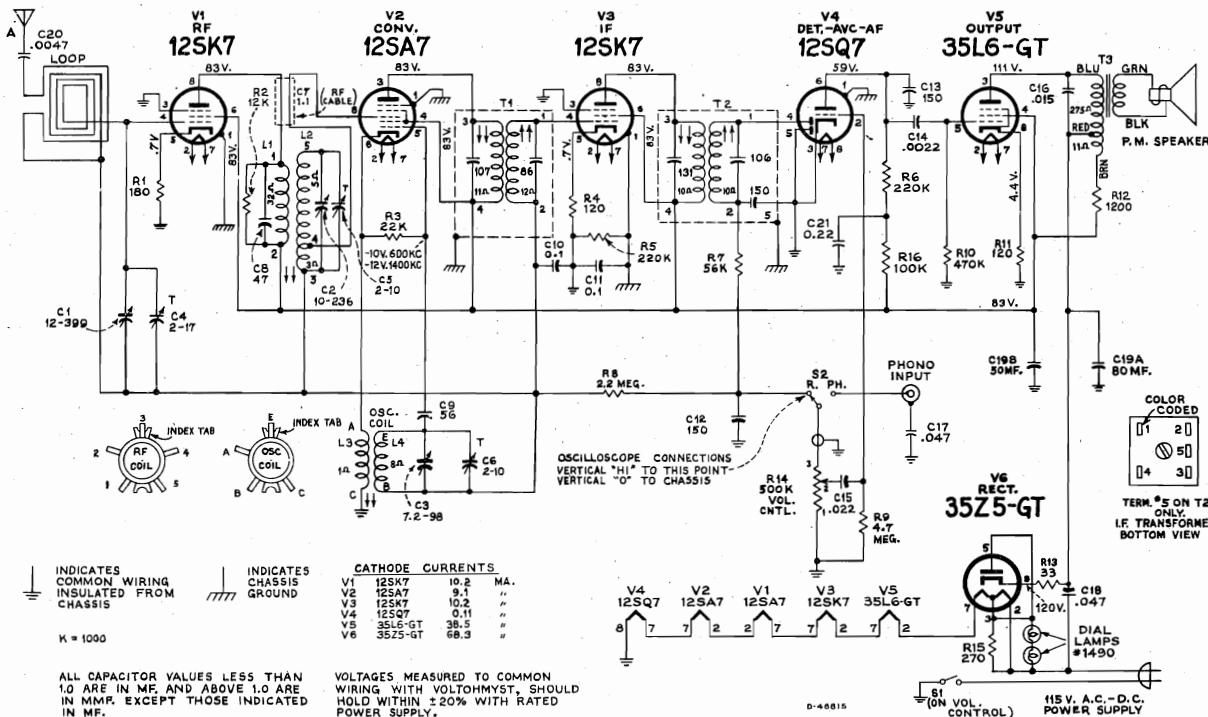

INDICATES COMMON WIRING INSULATED FROM CHASSIS

INDICATES CHASSIS CONNECTION TO GROUND

K = 1000

CATHODE CURRENTS

TUBE	CURRENT (MA.)
V1 12SK7	10.2
V2 12SA7	9.1
V3 12SK7	10.2
V4 12SQ7	0.11
V5 35L6-GT	38.5
V6 35Z5-GT	68.3

VOLTAGES MEASURED TO COMMON WIRING WITH VOLTOHMVST. SHOULD HOLD WITHIN ±20% WITH RATED POWER SUPPLY.

D-46815

MODELS 2C521, 2C522, 2C527,
Ch. RC1120, A, B, C

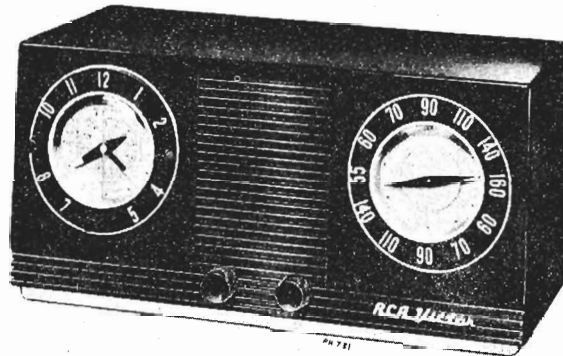

2C521
Maroon

2C522
Ivory

2C527
White

Specifications

Tuning Range540-1600 kc
Intermediate Frequency455 kc
Tube Complement:
(1) RCA 12BE6 Converter
(2) RCA 12BA6 I.F. Amplifier
(3) RCA 12AV6 Det.-AVC-A.F. Amp.
(4) RCA 50C5 Output
(5) RCA 35W4 Rectifier
Power Supply Rating:
115 volts a.c., 60 cycles30 watts
CAUTION:—DO NOT OPERATE ON D.C.
Appliance Rating115 volts, 15 a.

Loudspeaker:
Size and type4 in. P.M.
Voice Coil impedance3.2 ohms at 400 cycles

Power Output:
Undistorted1.2 watts
Maximum1.6 watts

Tuning Drive Ratio10 to 1 (5 turns of knob)
Weight5½ lbs.

Cabinet Dimensions:
Height...6⅞" Width...11¼" Depth...5½"

Operating Instructions

This instrument can be used in any one of several ways. It may be used as a clock with alarm alone, radio, phonograph amplifier, or clock-controlled radio or appliance outlet. Instructions for the various uses follow:

Clock—Plug instrument into a.c. outlet. The clock will start to operate immediately. Set the correct time with the "TIME-SET" knob on the back panel of the instrument. To set the alarm, pull out the "ALARM" knob and turn counter-clockwise until the desired time is indicated by the alarm pointer. Leave knob out for alarm buzzer operation. Push knob in to turn off buzzer.

Radio—1. Push "RADIO" slide switch lever to the right, as viewed from the back. Turn "RADIO" knob on clock from "OFF" to "ON" position. Adjust volume and tuning knobs as required after 30 second warm-up. Turn clock "RADIO" knob to "OFF" position when finished listening.

2. To have radio turn itself off after a period of up to 60 minutes, set "SLEEP" knob to desired playing time. Turn clock "RADIO" knob "OFF."

3. To have radio turn itself on, turn tuning and volume knobs to desired position, and then set the alarm as explained above. Turn clock "RADIO" knob to "AUTO" position.

4. To have the radio turn itself off during any time within a 60 minute period and then turn itself on, after an off period of up to twelve hours, set the "SLEEP" and "ALARM"

knobs, and volume and tuning controls as explained previously. Turn clock "RADIO" knob to "AUTO" position.

Appliances—1. To use appliance outlet, plug appliance into rear receptacle, and turn clock "RADIO" knob to "ON" position. If operation of the radio is not desired at the same time, push radio slide-switch lever on the back panel to the off position (lever pushed to the left).

2. To start appliance automatically, proceed as above, except that the "ALARM" knob should be set to the desired starting time, and the clock "RADIO" knob set to the "AUTO" position. To turn off appliance, turn clock "RADIO" knob to "OFF" position, or remove appliance plug if radio operation is desired.

3. To operate appliance for any time within a 60 minute period, have appliance plugged in, with clock "RADIO" knob turned to "OFF" position. Set "SLEEP" knob for desired operating period. Appliance will be turned off automatically at the end of this period.

Phonograph—1. Make sure radio slide switch is on (lever pushed to the right). Plug phonograph attachment audio plug into jack provided. Turn clock "RADIO" knob to "ON" position. If a spare a.c. receptacle is not available for the record changer, the appliance outlet may be used to provide power.

CAUTION:—Keep clock "RADIO" knob "OFF" when instrument is not in use.

MODELS 2-C-521 Series,
Ch. RC1120, A, B, C

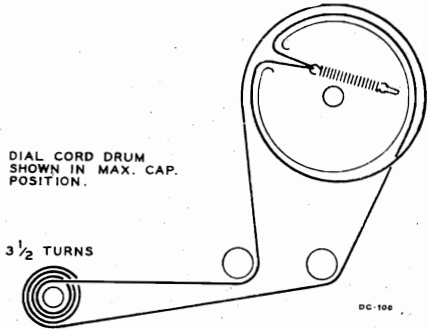

Dial Cord Drive

RADIO CHASSIS AND CLOCK SERVICE

Tube Service—To make tubes accessible for testing, remove the hex head screw at the lower right hand corner and the hex head screw at the left side of the appliance outlet on the back panel. The loop antenna and antenna trimmer are located on this back panel.

Radio Chassis Service—Proceed as above, removing the volume and tuning control knobs by pulling off, and also removing the three hex head screws and washers on the underside of the cabinet. Do Not remove the clock from the cabinet unless this is necessary for service. Lift off the shield on the underside of the chassis.

Clock Service—Proceed as above. Remove the three clock control knobs from the front of the cabinet by pulling off, taking care not to damage the clock control shafts. Using a small screwdriver or a small pry tool, remove the five sheet metal clips holding the clock to the cabinet. The clips will be found embedded in the plastic. The seal between the plastic and the metal teeth on the clips should be broken by lifting the metal edges till the teeth clear the plastic. To prevent scratching the plastic dial faces of the radio and clock, place the instrument face down on a thick soft cloth. When removing the clock, take care not to damage the molded-in plastic rim for mounting the clock.

In remounting the clock, new sheet metal clips should be used. These should be heated until hot enough to soften the plastic slightly upon contact. Place the clock in its mounting rim and push the heated clips on tightly, using a pair of pliers or other holding tool.

Attachment of Record Player

The audio output cable of the record player should be terminated with a pin plug.

Plug the cable into the receptacle which is accessible from the back of the cabinet.

Insertion of the cable plug into the receptacle removes radio signal from the volume control. The record player cable must be removed from the receptacle to permit radio operation.

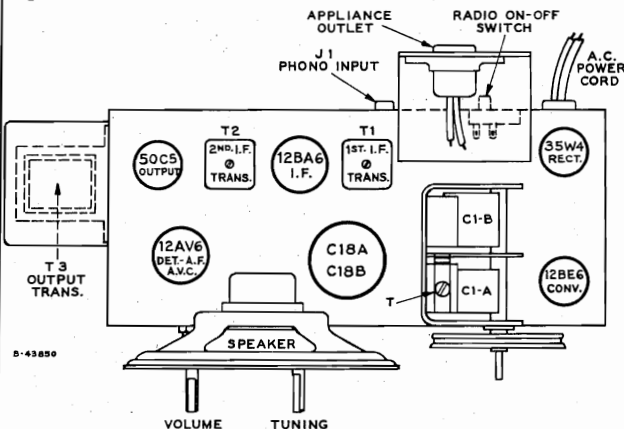

Chassis RC-1120, RC-1120A

Tube and Trimmer Locations

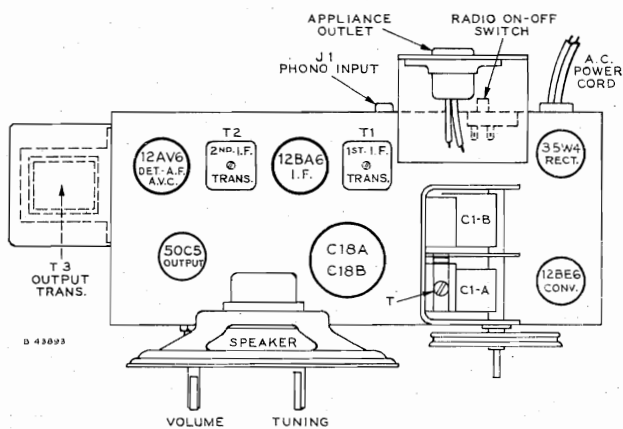

Chassis RC-1120B, RC-1120C

Alignment Procedure

Step	Connect the high side of test-oscillator to—	Tune test-osc. to—	Turn radio dial to—	Adjust the following for max. output
1	12BA6 I-F grid through .1 mfd. capacitor	455 kc	Quiet-point 1600 kc end of dial	T2 (top and bottom) 2nd I-F trans.
2	Stator of C1-2 through .1 mfd.			T1 (top and bottom) 1st I-F trans.
3	Short wire placed near loop to radiate signal	1620 kc	Min. cap.	osc. trimmer
4		1400 kc	1400 kc signal	ant. trimmer
5		Repeat steps 3 and 4.		

Test-Oscillator—For all alignment operations, connect the low side of the test-oscillator to the receiver chassis, and keep the oscillator output as low as possible to avoid a-v-c action.

On a.c. operation an isolation transformer (115 v./115 v.) may be necessary for the receiver if the test oscillator is also a.c. operated.

Lead Dress

1. Dress all capacitors down against chassis.
2. C-15 must be located so that connection to Pin #1 of 12AV6 is short as possible and condenser butts against rim of volume control.
3. Connect outside foil of all condensers as indicated in schematic diagram.
4. Dress Filament, B+ and B- leads down against chassis.
5. Dress R2, 12BA6 cathode resistor, down against tube center post with leads to Pin 2 and Pin 7 as short as possible.
6. Dress R3 above and away from R7.

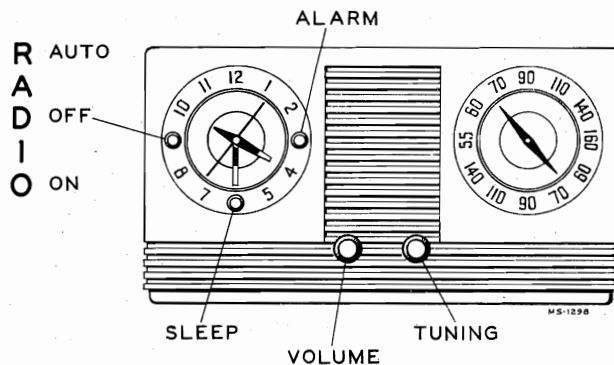

Clock Radio Controls

MODELS 2-C-521 Series,
Ch. RC1120, A, B, C

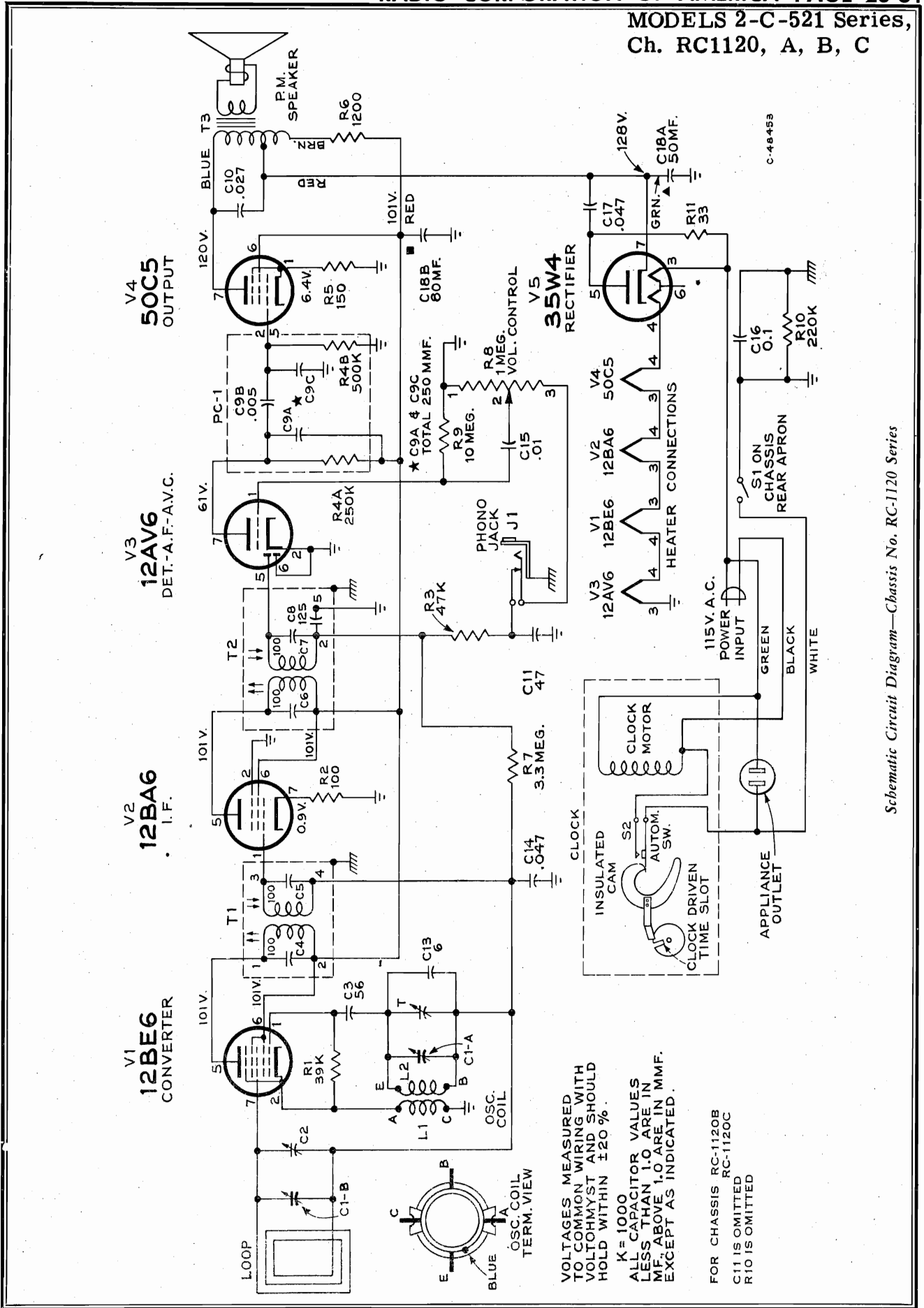

Schematic Circuit Diagram—Chassis No. RC-1120 Series

MODELS 2-C-521 Series,
Ch. RC1120, A, B, C

STOCK NO.	DESCRIPTION	STOCK NO.	DESCRIPTION
	CHASSIS ASSEMBLIES		SPEAKER ASSEMBLIES
	RC-1120, RC-1120B—Model 2-C-521 RC-1120A, RC-1120C—Models 2-C-522, 2-C-527		B12A512 RL108E7
77357	Capacitor—Variable tuning capacitor complete with drive drum . . . C1A, C1A-T, C1B	77226	Speaker—4" P.M. speaker complete with cone and voice coil (3.2 ohms)
77364	Capacitor—Ceramic, 6 mmf. C13		MISCELLANEOUS
76348	Capacitor—Ceramic, 47 mmf. C11	77367	Antenna—Antenna loop complete with back cover—maroon—for Model 2C521 (RC-1120, RC-1120A) Includes C2
77116	Capacitor—Ceramic, 56 mmf. C3	77904	Antenna—Antenna loop complete with back cover—maroon—for Model 2C521 (RC-1120B, RC-1120C)
73520	Capacitor—Electrolytic comprising 1 section of 80 mfd., 150 volts and 1 section of 50 mfd., 150 volts. C18A, C18B	77368	Antenna—Antenna loop complete with back cover—ivory—for Models 2C522, and 2C527 (RC-1120, RC-1120A) Includes C2
73561	Capacitor—Tubular, paper, .01 mfd., 400 volts. C15	77905	Antenna—Antenna loop complete with back cover—ivory—for Models 2C522, 2C527 (RC-1120B, RC-1120C)
73554	Capacitor—Tubular, paper, .027 mfd., 400 volts. C10	77367	Back—Cabinet back—maroon—and antenna loop for Model 2C521 (RC-1120, RC-1120A), Includes C2
73553	Capacitor—Tubular, paper, .047 mfd., 400 volts C14, C17	77904	Back—Cabinet back complete with antenna loop—maroon—for Model 2C521 (RC-1120B, RC-1120C)
73551	Capacitor—Tubular, paper, 0.1 mfd., 400 volts. C16	77368	Back—Cabinet back—ivory—and antenna loop for Models 2C522 and 2C527 (RC-1120, RC-1120A), Includes C2
73935	Clip—Mounting clip for I.F. transformer	77905	Back—Cabinet back complete with antenna loop—ivory—for Models 2C522, 2C527 (RC-1120B, RC-1120C)
77356	Coil—Oscillator coil L1, L2	X3304	Baffle—Baffle board and grille cloth for Model 2C521
75482	Connector—Phono input connector J1	X3305	Baffle—Baffle board and grille cloth for Models 2C522 and 2C527
52131	Connector—2 contact female connector for appliance outlet (RC-1120, RC-1120A)	Y2463	Cabinet—Plastic cabinet—maroon—complete with crystals (2) for Model 2C521
77901	Connector—2 contact female connector for appliance outlet (RC-1120B, RC-1120C)	Y2464	Cabinet—Plastic cabinet—ivory—complete with crystals for Model 2C522
77359	Control—Volume control R8	Y2465	Cabinet—Plastic cabinet—white—complete with crystals for Model 2C527
72953	Cord—250' Drive Cord Reel (approx. 26" required)	77372	Clip—Spring clip for mounting timer assembly (5 req'd)
70392	Cord—Power cord and plug	77033	Emblem—"RCA Victor" emblem
28451	Cover—Insulating cover for electrolytic	77369	Knob—Timer control knob—maroon—for Model 2C521
77360	Grommet—Rubber grommet for mounting tuning capacitor	77370	Knob—Timer control knob—ivory—for Model 2C522
28452	Plate—Bakelite mounting plate for electrolytic	77371	Knob—Timer control knob—white—for Model 2C527
77355	Plate—Dial back plate complete with pointed escutcheon (RC-1120, RC-1120A)	77373	Knob—Tuning control or volume control knob—maroon—for Model 2C521
77900	Plate—Dial back plate (RC-1120B, RC-1120C)	77374	Knob—Tuning control or volume control knob—ivory—for Model 2C522
77354	Pointer—Station selector pointer	77375	Knob—Tuning control or volume control knob—white—for Model 2C527
77365	Printed Circuit PC1 (C9A, C9B, C9C, R4A, R4B)	77013	Nut—Speed nut to fasten "RCA Victor" emblem to cabinet
77363	Pulley—Drive cord idler pulley	77491	Window—Polystyrene window for radio or timer dials
503033	Resistor—Fixed, composition:—		CLOCK ASSEMBLY
503110	33 ohms, ±10%, ½ watt R11		Clock—If clock mechanism repair becomes necessary, remove the clock from the radio. The RCA Victor Distributor in your area will advise you of the address of the nearest authorized service station for clock mechanisms. Repair facilities and replacement parts are available at these authorized service stations.
503115	100 ohms, ±10%, ½ watt R2		
503115	150 ohms, ±10%, ½ watt R5		
513212	1200 ohms, ±10%, 1 watt R6		
503339	39,000 ohms, ±10%, ½ watt R1		
503347	47,000 ohms, ±10%, ½ watt R3		
503422	220,000 ohms, ±10%, ½ watt R10		
503533	3.3 megohm, ±10%, ½ watt R7		
503610	10 megohm, ±10%, ½ watt R9		
77358	Shaft—Tuning knob shaft (RC-1120, RC-1120A)		
77909	Shaft—Tuning knob shaft (RC-1120B, RC-1120C)		
76870	Shield—Tube shield		
77115	Socket—Tube socket, 7 pin, miniature, moulded		
51955	Socket—Tube socket, 7 pin, miniature, moulded, saddle-mounted		
77361	Spring—Drive cord spring (RC-1120, RC-1120A)		
77902	Spring—Drive cord spring (RC-1120B, RC-1120C)		
32875	Switch—Radio power switch S1		
75486	Transformer—First I.F. transformer, complete with adjustable cores T1, C4, C5		
75487	Transformer—Second I.F. transformer, complete with adjustable cores T2, C6, C7, C8		
77362	Transformer—Output transformer (RC-1120, RC-1120A) T3		
77903	Transformer—Output transformer (RC-1120B, RC-1120C)		
33726	Washer—"C" washer for tuning knob shaft		

APPLY TO YOUR RCA DISTRIBUTOR FOR PRICES OF REPLACEMENT PARTS

MODEL 36QP, Ch.
RC1116, RC1116A

Tube and Trimmer Locations (Top View)

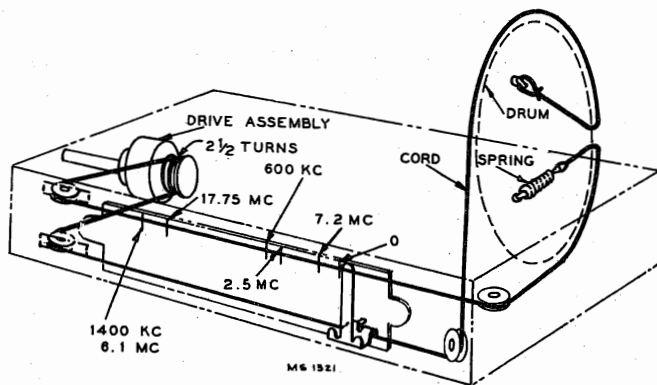
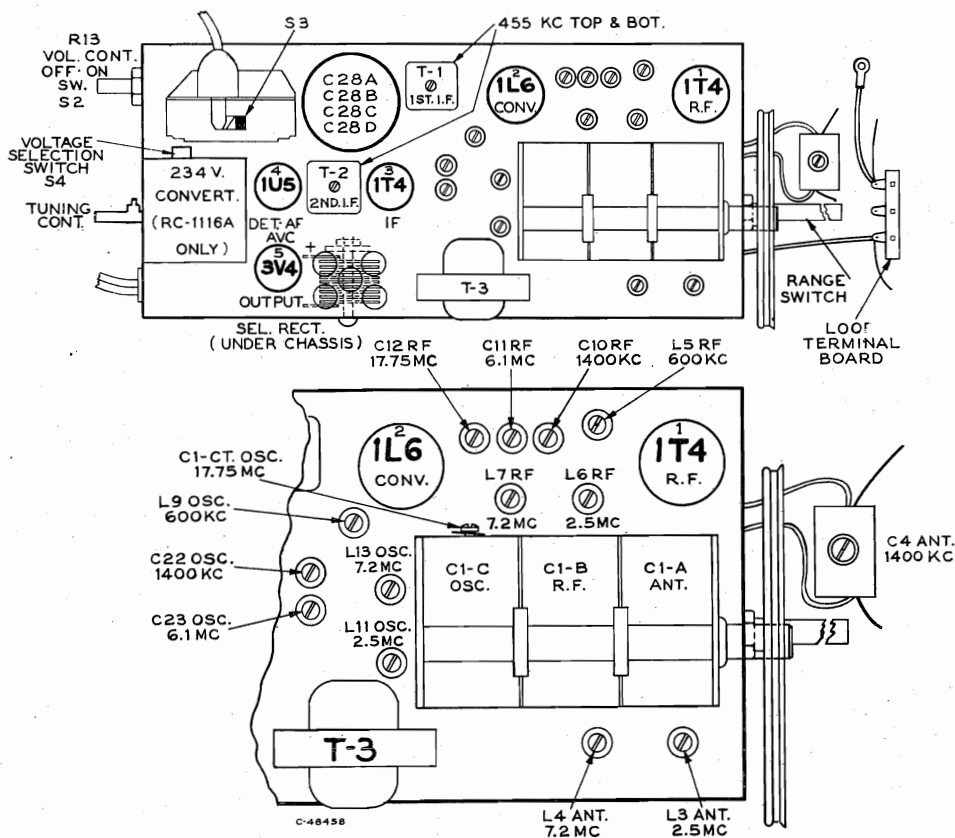

Dial Indicator and Drive Mechanism

Cord and indicator shown in position with drum in extreme clockwise position (condenser plates closed).

The left hand edge of indicator should coincide with the score marks on the dial back plate at the frequencies indicated.

To Remove Chassis

1. Pull out battery and disconnect battery plug.
2. Remove red wire from rod antenna.
3. Pull out on the two plastic loop supports to permit the loop antenna to be removed. When reinstalling, wedge the supports to the cabinet with two small pieces of wood (toothpick or equivalent).
4. Unsolder speaker voice coil leads.
5. Remove handle (see illustration above). Remove knobs (pull out).
6. Remove the two screws under link caps (visible when link caps are removed).

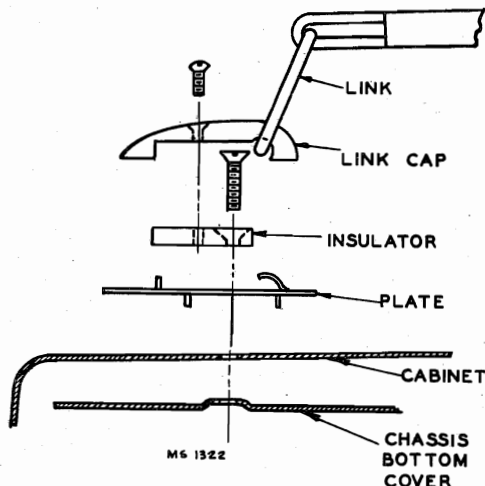

Chassis Mounting

To Remove Hinges

Remove back from cabinet as described above. Spread the hinge apart to remove it from the cabinet back.

To Remove Cabinet Back

With the back fully open, grip the cabinet as illustrated. Insert a screwdriver under one hinge and pry the center of the hinge out of the opening in the cabinet while maintaining pressure on the back with the fingers and on the cabinet with the thumb. Repeat this procedure with the other hinge. Pull the back straight to the rear using both hands.

MODEL 36QP, Ch.
RC1116, RC1116A

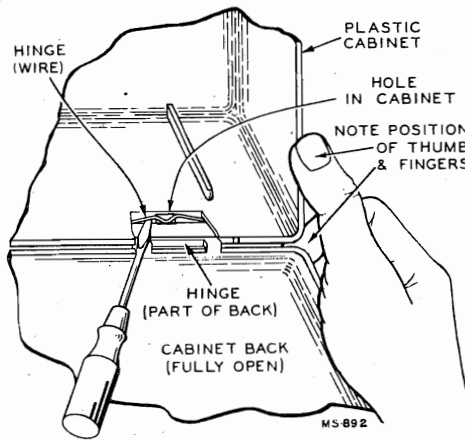

Removal of Cabinet Back

CRITICAL LEAD DRESS

1. Dress all filament leads close to the chassis.
2. Dress 33 ohm fuse resistor (R-18) up and away from all wiring.
3. Dress R-21 up and away from chassis.
4. Dress five section ceramic capacitor (C-27) close to chassis.
5. Keep "hot-side" lead of neutralizing capacitor (C-18) as short as possible and dress capacitor away from IF tube socket.
6. Dress C-19 up and away from IF transformer.
7. Dress all leads away from "C" oscillator coil.
8. Dress C-25 away from "B" oscillator coil.
9. Keep leads on R-3 as short as possible and dress close to 1L6 socket.
10. Dress R-1 and R-2 close to chassis base.
11. Dress loop leads away from tuning drum.
12. Dress lead from oscillator grid of 1L6 (pin #6) with 1/4" to 1/8" spacing from capacitor-resistor assembly C-14/R-6.

Power Line Operation

A power cord is stored alongside of the battery inside the case. Its plug is inserted in a socket on the chassis. For power line operation: remove the plug from its socket and insert it into a convenient power supply outlet.

Make sure that the power cord passes through the notch provided in the side of the back cover.

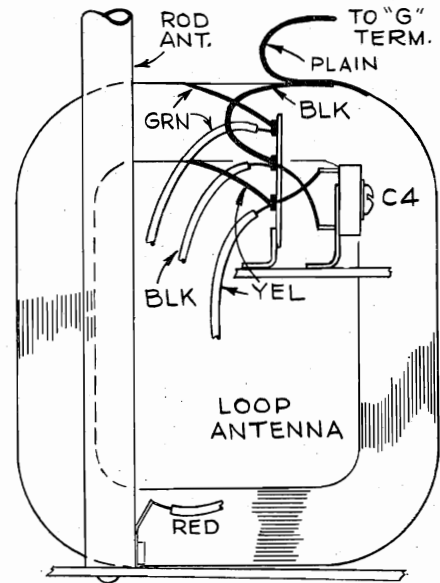

A-43405

Loop Antenna Connections

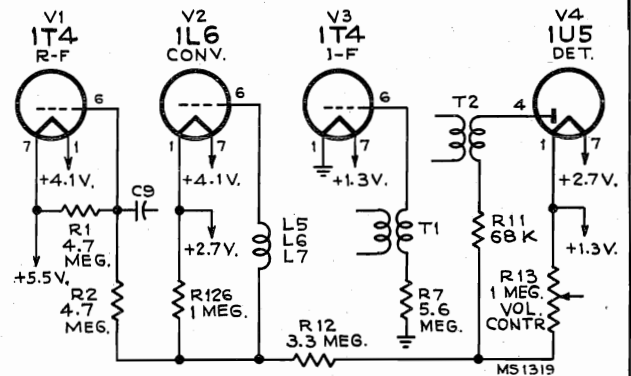

AVC Circuit

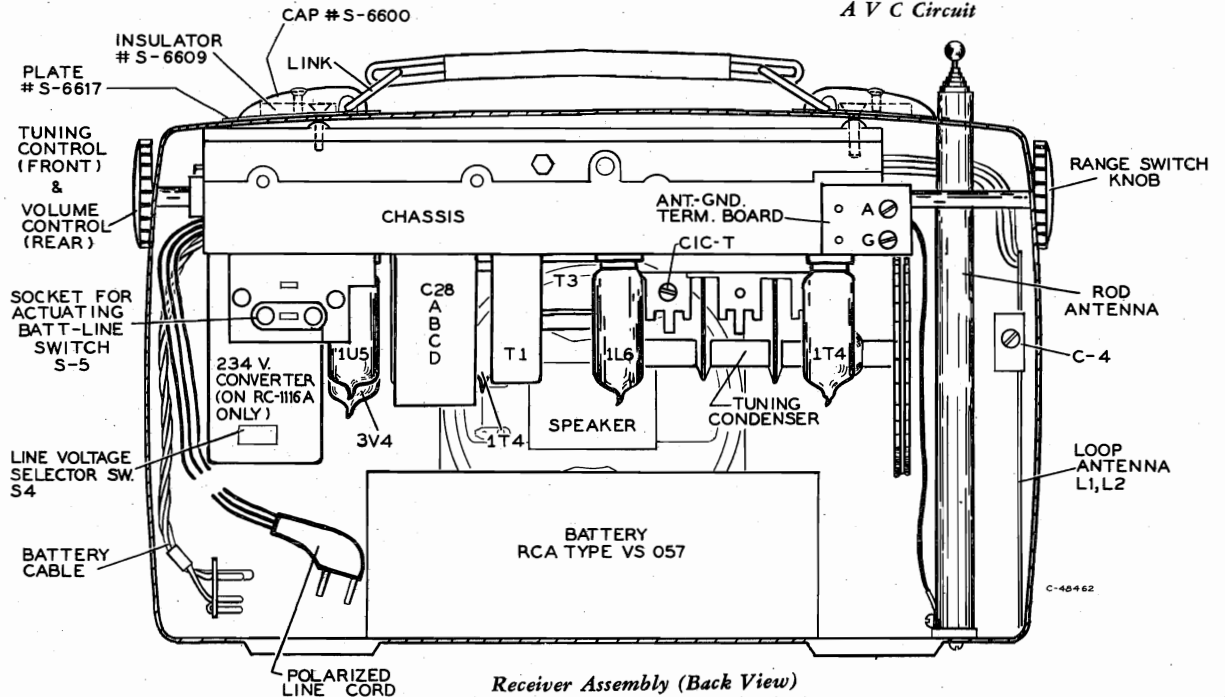

Receiver Assembly (Back View)

MODEL 36QP, Ch.
RC1116, RC1116A

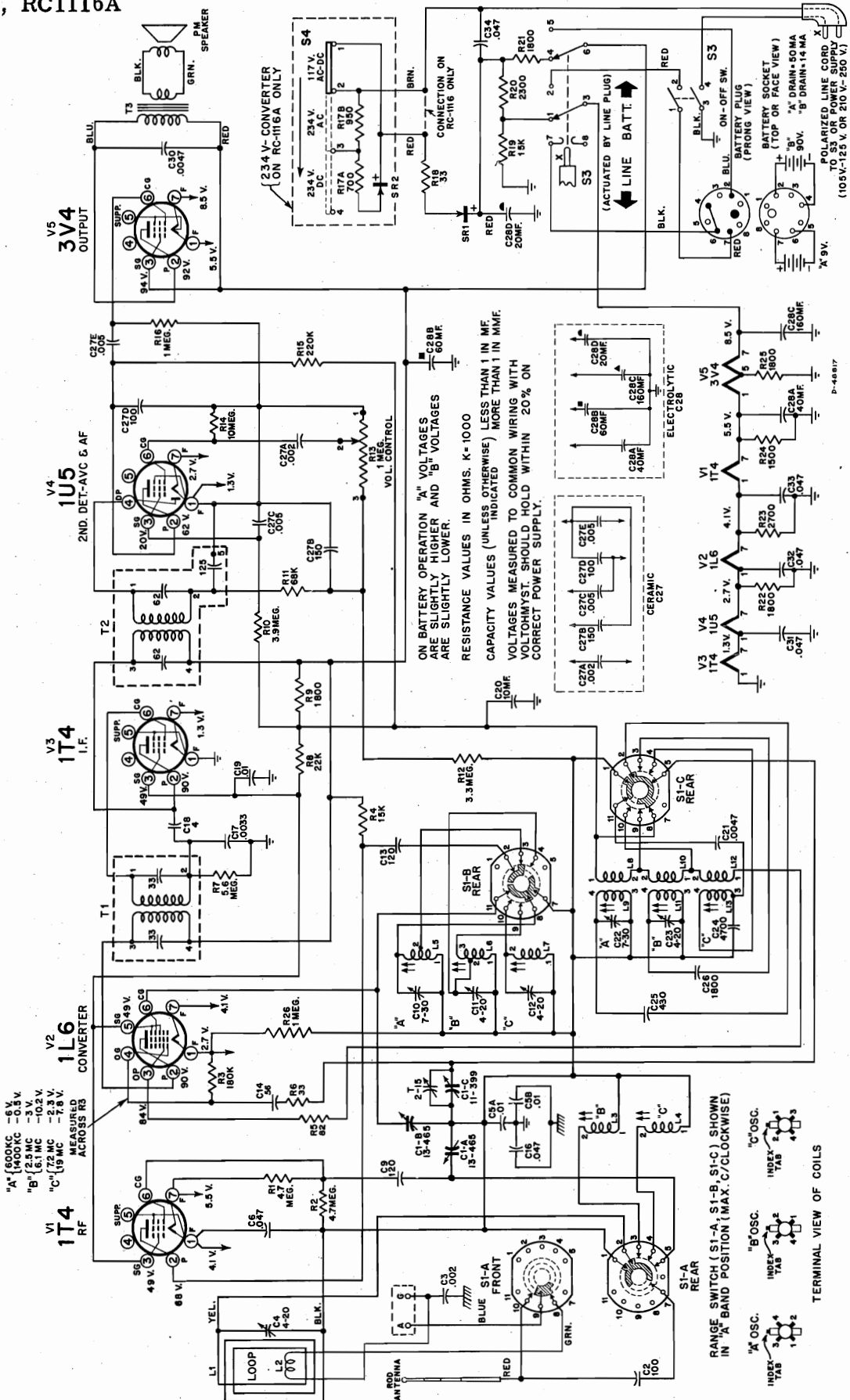

STOCK No.	DESCRIPTION	STOCK No.	DESCRIPTION
CHASSIS ASSEMBLY RC1116			
S-6561	Board—ANT-GND terminal board	S-6587	3.9 megohm, ½ watt (R10)
S-6562	Bracket—Dial cord pulley bracket complete with two pulleys—(tuning drum end.)	S-5176	4.7 megohm, ½ watt (R1, R2)
S-6563	Capacitor—Trimmer capacitor, 4-20 mmf. (C11, C12, C23)	S-5177	5.6 megohm, ½ watt (R7)
75189	Capacitor—Trimmer capacitor, 7-30 mmf. (C10, C22)	S-6588	10 megohm, ½ watt (R14)
Capacitors—Fixed		S-6589	Shaft—Tuning control drive shaft assembly
S-5128	Ceramic, 4 mmf. (C18)	S-6322	Socket—Tube socket for V1 (1T4) or V2 (1L6)
45233	Ceramic, 100 mmf. (C2)	S-6590	Socket—Tube socket for V3 (1T4)
S-5131	Ceramic, 120 mmf. (C9, C13)	S-6591	Socket—Tube socket for V4 (1U5) or V5 (3V4) tubes
S-6724	Mica, 430 mmf. (C25)	S-4511	Spacer—Metal spacer for mounting tuning condenser (3 req'd)
S-5136	Mica, 1800 mmf. (C26)	S-4485	Spring—Drive cord tension spring
S-5942	Mica, 4700 mmf. (C24)	S-6592	Switch—Tuning range switch (S1-A, S1-B, S1-C)
S-6564	Ceramic, .0022 mf. (C3)	S-5186	Switch—Battery-line switch assembly (S3)
S-4853	Molded paper, .0033 mf., 600V. (C17)	S-5229	Transformer—First I-F transformer (T1)
S-9371	Ceramic, .0047 mf. (C21)	S-5230	Transformer—Second I-F transformer (T2)
S-5469	Molded paper, .0047 mf., 600V. (C30)	S-6593	Transformer—Output transformer (T3)
S-6326	Ceramic, .01 mf. (C19)	CHASSIS ASSEMBLIES RC1116A	
75877	Ceramic, dual, two sections of .01 mf. (C5A, C5B)	Same as RC1116 except for addition of 234V. converter	
S-6565	Ceramic, five sections, (.002 mf. C27A) (150 mmf. C27B) (.005 mf. C27C) (100 mmf. C27D) (.005 mf. C27E)	S-6594	Converter—117V./234V. converter assembly complete
S-4706	Molded paper, .047 mf., 400V. (C6, C16, C31, C32, C33)	74322	Rectifier—Selenium rectifier (SR2)
S-5144	Molded paper, .047 mf., 600V. (C34)	S-6595	Resistor—Tapped wire wound resistor 700 and 950 ohms (R17A, R17B)
S-5145	Electrolytic, 10 mf., 150V. (C20)	S-6596	Switch—117V./234V. converter switch (S4)
S-5146	Electrolytic, comprising one section of 40 mf., 25V., one section of 60 mf., 150V., one section of 160 mf., 25V., and one section of 20 mf., 150V. (C28A, C28B, C28C, C28D)	SPEAKER ASSEMBLY STAMPED 970654-2	
S-4523	Capacitor and Resistor—Assembly comprising 56 mmf. capacitor and 33 ohm resistor (C14, R6)	S-6597	Speaker—4 inch PM speaker complete with cone and voice coil
S-4454	Clip—Clip for mounting I-F transformers (2 req'd)	MISCELLANEOUS	
S-6567	Coil—"A" band oscillator coil complete with adjustable core (L8, L9)	S-6598	Antenna—"A" band loop antenna (L2)
S-6568	Coil—"B" band oscillator coil complete with adjustable core (L10, L11)	S-6599	Antenna—Telescoping rod antenna
S-6569	Coil—"C" band oscillator coil complete with adjustable core (L12, L13)	S-6622	Back—Cabinet back—GREY
S-6570	Coil—"A" band R-F coil complete with adjustable core (L5)	S-6623	Back—Cabinet back—RED
S-6571	Coil—"B" band R-F coil complete with adjustable core (L6)	S-6600	Cap—Carrying handle link cap (2 req'd)
S-6572	Coil—"C" band R-F coil complete with adjustable core (L7)	S-6601	Capacitor—Trimmer capacitor and bracket assembly (C4)
S-6573	Coil—"B" band ant. coil (L3)	S-6602	Case—Plastic case (front and back) GREY—less handle, grille and loop antenna
S-6574	Coil—"C" band ant. coil (L4)	S-6603	Case—Plastic case (front and back) RED—less handle, grille and loop antenna
S-6575	Condenser—Variable tuning condenser (C1-A, C1-B, C1-C)	S-6604	Catch—Metal catch (on case front) to hold cabinet back (2 req'd)
S-6576	Control—Volume control and on-off switch (R13, S2)	S-6605	Clip—Metal clip (on case back) to hold cabinet back (2 req'd)
S-6577	Cover—Chassis bottom cover	S-6606	Grille—Perforated metal grille
S-6578	Cord—Tuning indicator drive cord (41 inches required)	S-4463	Grommet—Rubber grommet for speaker mounting (4 req'd)
S-5149	Cord—Power line attachment cord	S-6607	Dial—Plastic dial scale
S-4464	Grommet—Rubber grommet to mount tuning condenser (3 req'd)	S-6355	Emblem—"RCA Victor" emblem
S-6579	Indicator—Tuning indicator pointer	74790	Hinge—Cabinet hinge (2 req'd)
S-6580	Pin—Axle pin for drive cord pulleys (tuning control end)	S-6608	Handle—Carrying handle—less links
S-6581	Plate—Dial back plate	S-6609	Insulator—Insulating plate (under link caps)
18469	Plate—Insulating plate to mount electrolytic capacitor	S-6610	Knob—Tuning knob—GREY
S-5159	Plug—Five pin plug for battery cable	S-6611	Knob—Tuning knob—RED
S-5123	Pulley—Drive cord pulley (tuning control end) (2 req'd)	S-6612	Knob—Range switch knob—GREY
S-6582	Rectifier—Selenium rectifier (SR1)	S-6613	Knob—Range switch knob—RED
S-6583	Resistor—Armored wire wound, 2300 ohms, 7 watt (R20)	S-6614	Knob—Volume control knob—GREY
Resistors—Fixed Composition		S-6615	Knob—Volume control knob—RED
S-6584	33 ohms, 1 watt (R18)	S-6616	Link—Carrying handle link (2 req'd)
S-6723	82 ohms, ½ watt (R5)	S-6617	Plate—Decorative plate for top of cabinet (under link caps) (2 req'd)
S-5163	1500 ohms, ½ watt (R24)	S-6618	Screw—#6-32 X ¾" hex head machine screw for mounting speaker (4 req'd)
S-5164	1800 ohms, ½ watt (R9, R21, R22, R25)	S-6619	Screw—#4 self tapping screw to hold clip catch to cabinet front (2 req'd)
S-5167	2700 ohms, ½ watt (R23)	S-6620	Screw—#6 self tapping oval head screw to hold dial to cabinet (2 req'd) or link caps to insulator plate (2 req'd)
36714	15,000 ohms, ½ watt (R4)	S-6621	Spacer—Metal spacer for speaker mounting (4 req'd)
S-6585	15,000 ohms, 1 watt (R19)	S-6086	Spring—Retaining spring for knobs
S-6395	22,000 ohms, ½ watt (R8)		
S-6173	68,000 ohms, ½ watt (R11)		
S-6586	180,000 ohms, ½ watt (R3)		
S-5647	220,000 ohms, ½ watt (R15)		
S-6240	1 megohm, ½ watt (R16, R26)		
S-5175	3.3 megohm, ½ watt (R12)		

MODEL 3-RF-91,
Ch. RC1129



Model 3-RF-91 "Woodland"
Maroon

SPECIFICATIONS

TUNING RANGES

Standard Broadcast (AM) 540-1600 kc.
Frequency Modulation (FM) 88-108 mc.
Intermediate Frequencies AM—455 kc., FM—10.7 mc.

TUBE COMPLEMENT

- (1) RCA 6CB6 R.F. Amplifier
- (2) RCA 6X8 Mixer-Oscillator
- (3) RCA 6BA6 (AM-FM) I.F. Amplifier
- (4) RCA 6AU6 2nd FM I.F. Stage
- (5) RCA 6AU6 3rd FM I.F. Stage
- (6) RCA 6AL5 F.M. Detector
- (7) RCA 6AV6 AM Det.-AVC-Audio
- (8) RCA 6V6-GT Audio Output
- (9) RCA 5Y3-GT Rectifier

CIRCUIT DESCRIPTION

This instrument, a deluxe AM-FM table radio, has nine tubes, including rectifier. RF circuits, contained on a two tube sub-chassis, include RF amplification for both bands and a combination mixer-oscillator circuit. Special shielding and filtering have been incorporated to reduce oscillator radiation. The mixer is pentode connected for AM operation; triode connected for FM operation. AM IF circuits use an IF amplifier and conventional diode detector with AVC. FM IF circuits include three IF stages and a ratio detector. The two tube audio amplifier has an adjustable tone control circuit with combination bass and treble compensation. A hum-bucking circuit uses the tapped-winding output transformer. A ferrite core AM antenna, and line cord FM antenna, allow reception without the use of external antennas. A phono jack at the instrument rear permits the use of a record player attachment.

POWER SUPPLY RATING

115 volts, 60 cycles 80 watts

DIAL LAMPS 2 No. 44, 6-8 volts, 0.25 amp.

LOUDSPEAKER

Size and Type 8" P.M.
Voice Coil Impedance 3.2 ohms

AUDIO POWER OUTPUT

Undistorted 2.5 watts
Maximum 3.5 watts

TUNING DRIVE RATIO 7¼:1 (3⅞ turns of knob)

NET WEIGHT 19 lbs.

DIMENSIONS (Overall)

Height 10" Width 16½" Depth 9"

OPERATING INSTRUCTIONS

RADIO—Turn OFF-VOLUME control about half-way in a clockwise direction to turn receiver ON and provide for medium VOLUME. Allow a short warm-up period. Set FUNCTION control at desired service—AM or FM. Rotate TUNING control to move the pointer to the desired AM or FM frequency. Adjust VOLUME and TONE controls as desired.

PHONOGRAPH—Connect attachment to PHONO jack at instrument rear. Switch the FUNCTION control to "PH" position. Turn on receiver and adjust VOLUME and TONE controls as desired.

ANTENNAS:

Under average conditions the receiver does not require an external antenna. However, provision is made for the use of external antenna if desired—connect as indicated below:

AM antenna: Open the link (normally connects terminals #1 and #2). Connect a single wire antenna to terminal #1.

FM antenna: Remove the built-in antenna lead from #3 terminal. Connect the transmission line (300 ohm) from an external dipole antenna to terminals #2 and #3.

Ground: An external ground can be attached to terminal #2 if desired. Under some conditions an external ground is detrimental to FM reception.

NOTE: For satisfactory reception on FM when using the built-in FM antenna the power cord must be fully extended and must not be coiled or hanked up.

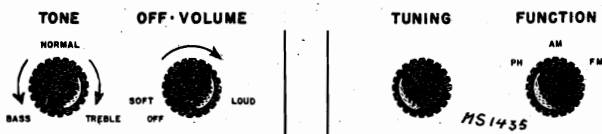

(Left side of cabinet)

(Right side of cabinet)

Radio Controls

MODEL 3-RF-91,
Ch. RC1129

TUBE AND TRIMMER LOCATIONS—VOLTAGE DATA

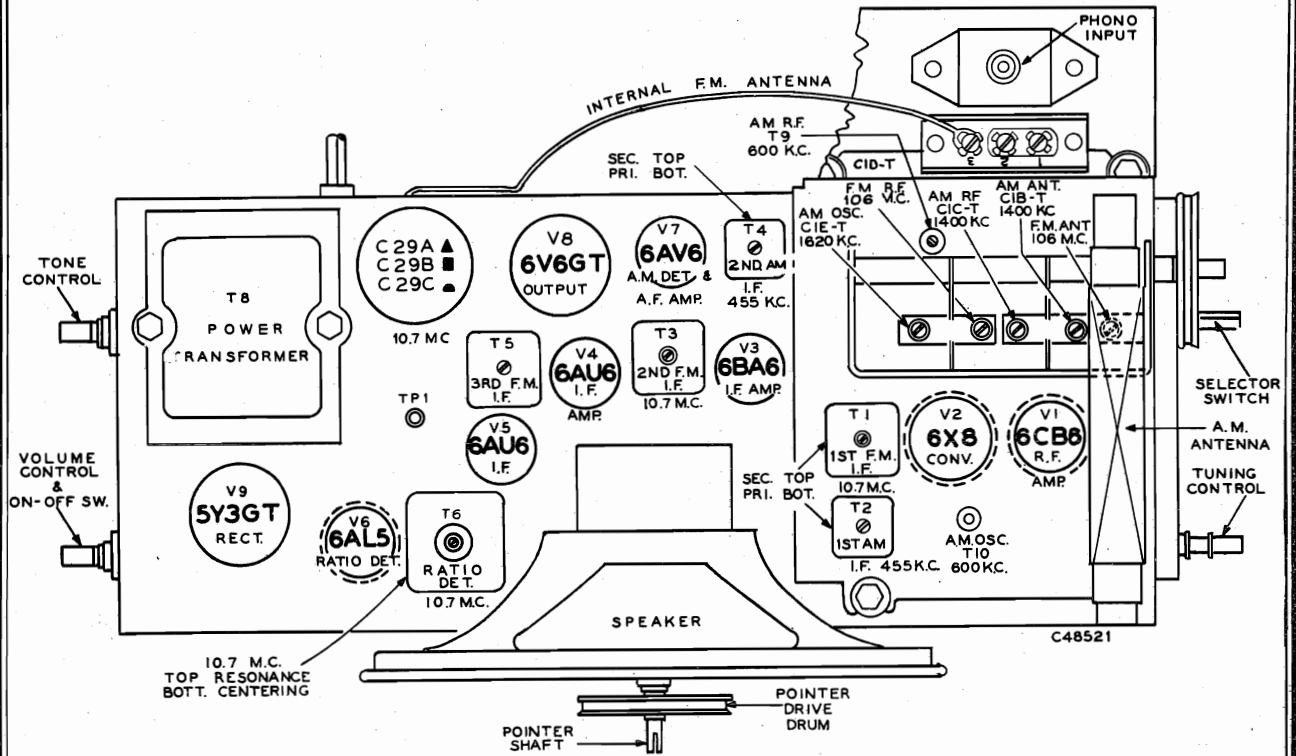

Tube and Trimmer Locations

VOLTAGE CHART

Tube	Type	Elements	Pin No.	"AM"	"FM"	Phono.
1	RF amp. 6CB6	Plate	5	195	128	—
		Screen	6	96	65	—
		Cathode	2	0.4	0.5	—
		Grid	1	-1.4	-0.2	—
2	Mixer 6X8	Plate	9	39	38	—
		Screen	8	39	38	—
		Grid	7	-2.8	-1.5	—
		Osc.	3	79	66	—
3	IF amp. 6BA6	Plate	5	195	187	218
		Screen	6	122	100	130
		Cathode	7	0.8	0.9	0.9
		Grid	1	-1.6	—	-1.2
4	IF amp. 6AU6	Plate	5	200	195	222
		Screen	6	65	62	69
		Cathode	7	0.55	0.55	0.65
		Grid	1	—	—	—
5	IF amp. 6AU6	Plate	5	52	50	56
		Screen	6	49	47	53
		Cathode	7	0.36	0.35	0.4
		Grid	1	-0.34	-0.34	-0.3
6	Ratio Det. 6AL5	—	—	—	—	—
7	AF amp. 6AV6	Plate	7	69	69	73
		Grid	1	-0.8	-0.8	-0.8
8	Output 6V6GT	Plate	3	242	240	243
		Screen	4	200	195	222
		Cathode	8	11.1	10.7	12.6
9	Rectifier 5Y3GT	Fil.	8	257	254	260

CATHODE CURRENTS (MA)

Tube	Terminal	"AM"	"FM"	Phono.	
1	6CB6	2	6.2	7.9	—
2	6X8	6	5.2	5.2	—
3	6BA6	7	11.6	13.4	13.8
4	6AU6	7	5.0	4.7	5.4
5	6AU6	7	3.3	3.0	3.6
6	6AL5	—	—	—	—
7	6AV6	2	0.3	0.3	0.36
8	6V6GT	8	34	33	37
9	5Y3GT	8	67	69	62

The heater voltage of the mixer/oscillator tube (6X8) is approx. 0.4 volt lower than other tubes in the same circuit. This is due to the filament choke coils L7 and L8.

Voltages and currents measured with tuning condenser closed and no signal input should hold within $\pm 20\%$ with rated line voltage.

RCA VoltOhmyst used for measuring all voltages.

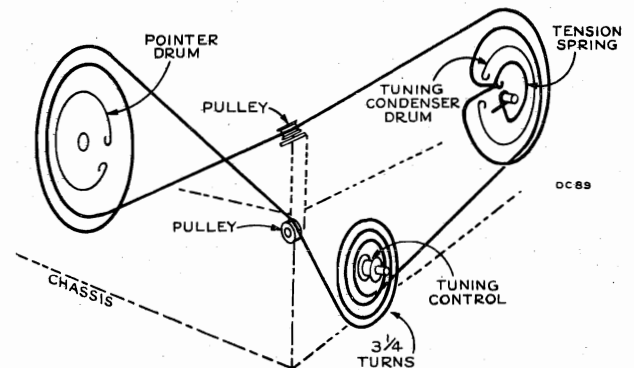

Dial Cord and Drive Assembly

MODEL 3-RF-91,
Ch. RC1129

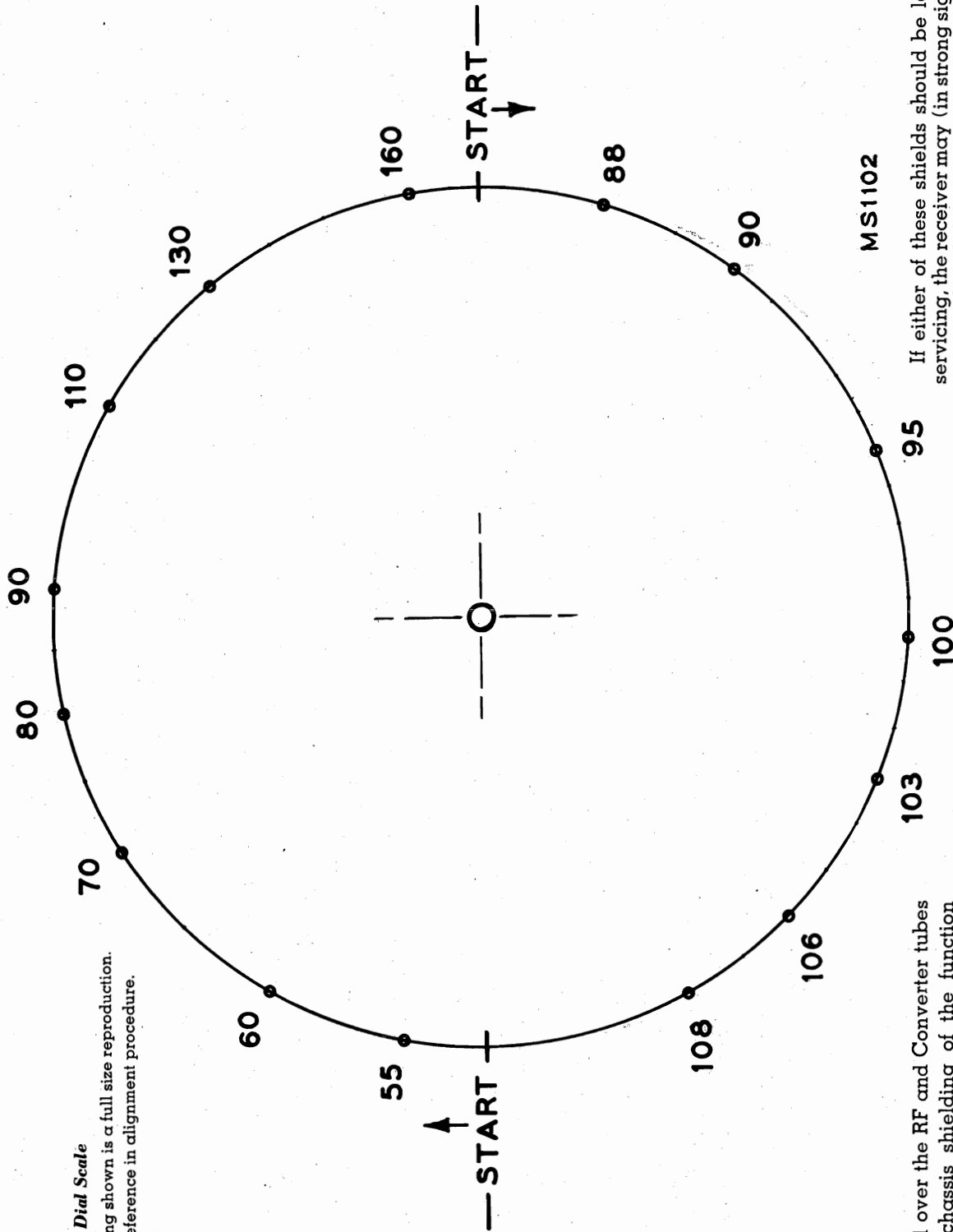

Dial Scale

The dial scale drawing shown is a full size reproduction. It can be used as a reference in alignment procedure.

SHIELDING

The box shield over the RF and Converter tubes and the under chassis shielding of the function switch reduces the FM oscillator radiation of Model 3-RF-91 to a point within limits established by the Federal Communications Commission.

MS1102

If either of these shields should be left off after servicing, the receiver may (in strong signal areas) apparently still function normally but the FM oscillator radiation will be greatly increased. This radiation will have an adverse effect on nearby television receivers and other FM radios.

ALWAYS REPLACE ALL SHIELDS

MODEL 3-RF-91,
Ch. RC1129

ALIGNMENT PROCEDURE

Due to the use of separate I.F. transformers, there is little interaction between the 10.7 mc. and the 455 kc. adjustments. There is a slight interaction of adjustments on the tuning condenser between AM and FM.

If a large amount of adjustment is required of any circuit, all others should be checked in the following order:

- FM I.F.
- AM I.F.
- AM Osc., ant. and r.f.
- FM Osc., ant. and r.f.

Final adjustment of AM ant. trimmer should be made with chassis and antenna in cabinet.

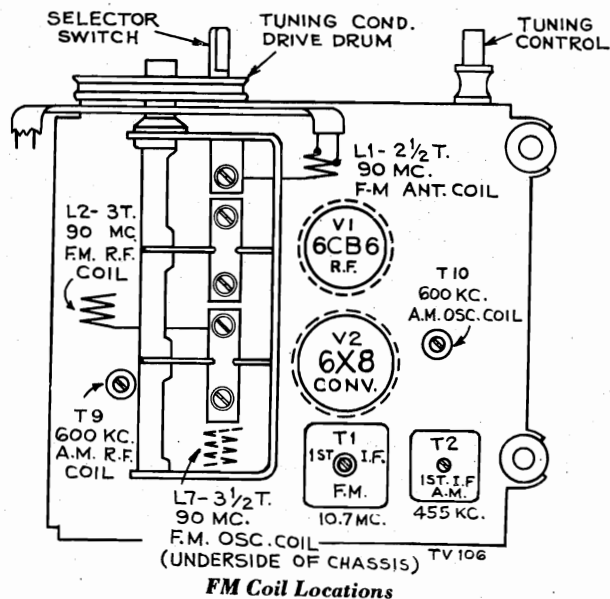

FM Coil Locations

Alignment Indicators:

For measuring the developed d-c voltage across C36 during FM alignment an RCA VoltOhmyst or an equivalent meter should be used. An output meter connected across the voice coil is also needed to indicate minimum audio output during FM Ratio Detector alignment.

The RCA VoltOhmyst can also be used to indicate audio output voltage across the voice coil or developed voltage on the AVC bus.

Signal Generator:

For alignment operations connect the low side of the signal generator to the receiver chassis. The output of the signal generator should always be controlled to prevent over-loading or excessive AVC action.

Oscilloscope Alignment:

It is preferable to use a sweep generator and oscilloscope for aligning I.F. and R.F. circuits to obtain a visual observation of curve shape during alignment.

With FM sweep generator connected between FM ant. (#3) terminal and chassis, and oscilloscope connected between the junction of R39-C32 and chassis, the overall FM linearity may be observed. With 100% FM modulation there should be a peak-to-peak separation of 150 kc. with 50,000 microvolts input before noticeable distortion of the sine wave is present.

For FM alignment of the ratio detector, connect oscilloscope to junction of 56K resistors as in alignment table, adjusting T6 top and bottom cores for 10.7 mc. crossover and balanced peaks. When aligning other FM tuned circuits, connect oscilloscope to TP1. Follow alignment table sequence, adjusting for maximum gain and symmetry.

AM Alignment

RANGE SWITCH IN AM POSITION

Steps	Connect high side of sig. gen. to—	Sig. gen. output	Turn radio dial to—	Adjust for peak output
1	Pin 1 of V3 6BA6 in series with .01 mfd.	455 kc.	Quiet point at low freq. end	T4 bottom core (pri.) T4 top core (sec.)
2	Tap terminal T9 term. 4 in series with .01 mfd.			T2 top core (sec.) T2 bottom core (pri.)
3	No. 1 terminal on ant. input strip	1620 kc.	High freq. end of dial (min. cap.)	C1E-T
4		1400 kc.	1400 kc. signal	C1B-T ant. C1C-T r.f.
5		Shunt a 10,000 ohm resistor across the r.f. section of the gang.		
6		600 kc.	600 kc. signal	T10 osc.* (Rock gang.)
7		Remove the 10,000 ohm resistor and peak T9 r.f.*		
8	Repeat 3, 4, 5, 6 and 7			

* The correct adjustment of the Osc. (T10) core is that peak obtained with core furthest away from the coil mounting clips. R.F. (T9) core should be set to the peak obtained (2 peaks are seldom obtainable) with core closest to the mounting clips.

MODEL 3-RF-91,
Ch. RC1129

CRITICAL LEAD DRESS

1. Lead from lug terminal "B" of the 1st FM transformer to rear switch wafar terminal #10 should not be changed from the original, 3 inches long plus or minus 1/4" of #22 copper vinylite covered.
2. A.C. leads from power switch on volume control should be dressed as far as possible from the audio-leads and audio coupling condensers near or connecting to the volume control terminals.
3. Ground straps between the R.F. shelf and the main chassis should not be relocated.
4. The connection point of capacitor C13 is critical, therefore should not be altered. It must be connected to the function switch and not to the I.F. transformer.

RANGE SWITCH FUNCTIONS

The range switch has five functions:

1. Selection of AM or FM tuning ranges.
2. Selection and distribution of AVC voltages. Full AVC is applied to V1, V2 and V3 in AM position. No AVC is used on FM operation, the grid circuits of V1, V2, V3 being grounded through S1A.
3. Controls the application of B+ voltages to the plate and screen circuits of V1 and V2 (disconnected in phono position).
4. Controls audio input to volume control.
5. Switches mixer section of V2 (6X8) from pentode operation on AM to triode operation in FM position, and selects proper I.F. transformer (AM or FM).

FM Alignment

†† Alternate loading may be necessary to provide accurate observation of peaks.

Alternate loading involves the use of a 680 ohm resistor to load the plate winding while the grid winding of the SAME TRANSFORMER is being peaked. Then the grid winding is loaded with the resistor while the plate winding is peaked. Only one winding is loaded at any one time. Remove the 680 ohm resistor after T3 and T1 have been aligned.

Oscillator frequency is above signal frequency on both AM and FM.

Extreme care should be used to avoid running the I.F. cores all the way through the winding and out the other end.

** Note: FM antenna, mixer and oscillator coils are adjustable by increasing or decreasing the spacing between turns. The location of the tap on the antenna coil is 1/8 turn to 1/4 turn from the ground end.

RANGE SWITCH IN FM POSITION—
VOLUME CONTROL MAXIMUM—TONE CONTROL CENTER

Steps	Connect high side of sig. gen. to—	Sig. gen. output	Turn radio dial to—	Adjust for peak output
1	Pin 1 of V5 6AU6 in series with .01 mfd.	10.7 mc. modulated 30% 400 cycles	Quiet point at low freq. end	
2	Connect VoltOhmyst across R41-39K resistor. Adjust Sig. gen. output to give 1 volt d-c on VoltOhmyst.			T6 top core for max. d-c voltage across C36
3	Shunt R41 with two 56K ±1% resistors connected in series. Connect VoltOhmyst from center junction of 56K resistors to junction of R39 and C32.			T6 bottom core for 0 volts d-c
4	Pin 1 of V3 6BA6 in series with .01 mfd.	10.7 mc. modulated 30% 400 cycles	Quiet point at low freq. end	VoltOhmyst conn. to TP1. ††T5 top core. T3 top & bottom cores. †††T1 top and bottom cores.
5	Stator of C1D in series with .01 mfd.			
6	FM Ant. terminals 270 ohm resistor in series #3 term.	90 mc.	90 mc.	Remove bottom shield. **Osc. coil L3
7		106 mc.	106 mc. signal	Replace bottom shield. C1A-T ant., C1D-T r.f.
8		90 mc.	90 mc.	**L1 ant. L2 r.f.
9	Repeat steps 6, 7, and 8 until further adjustment does not improve calibration.			

CORE PEAKING

Incorrect peaking can seriously affect gain and bandwidth. The correct peak is noted for the various coils and transformers.

1. The RF transformer core screw should be adjusted on the peak position furthest removed from the coil mounting clip. An incorrect peak may sometimes be obtained with the core screw almost all the way into the clip.
2. The oscillator coil (AM) should be adjusted on the peak obtained with the core coming out the lug end of the coil. When adjusting from the top of the chassis, this is the peak with the core furthest into the coil.
3. The position of the FM IF transformer screws should be noted after adjustment. These cores should be peaked with the core part way out of the coil toward the adjusting hole. It is possible to run the IF cores all the way through the FM windings and obtain a second peak. This will cause serious overcoupling and should be avoided by using a marked adjusting stick. The correct peak is always the first peak obtained when the core is started in from the "backed all the way out" position.

SIMPLIFIED SCHEMATIC
 DIAGRAM—"AM"

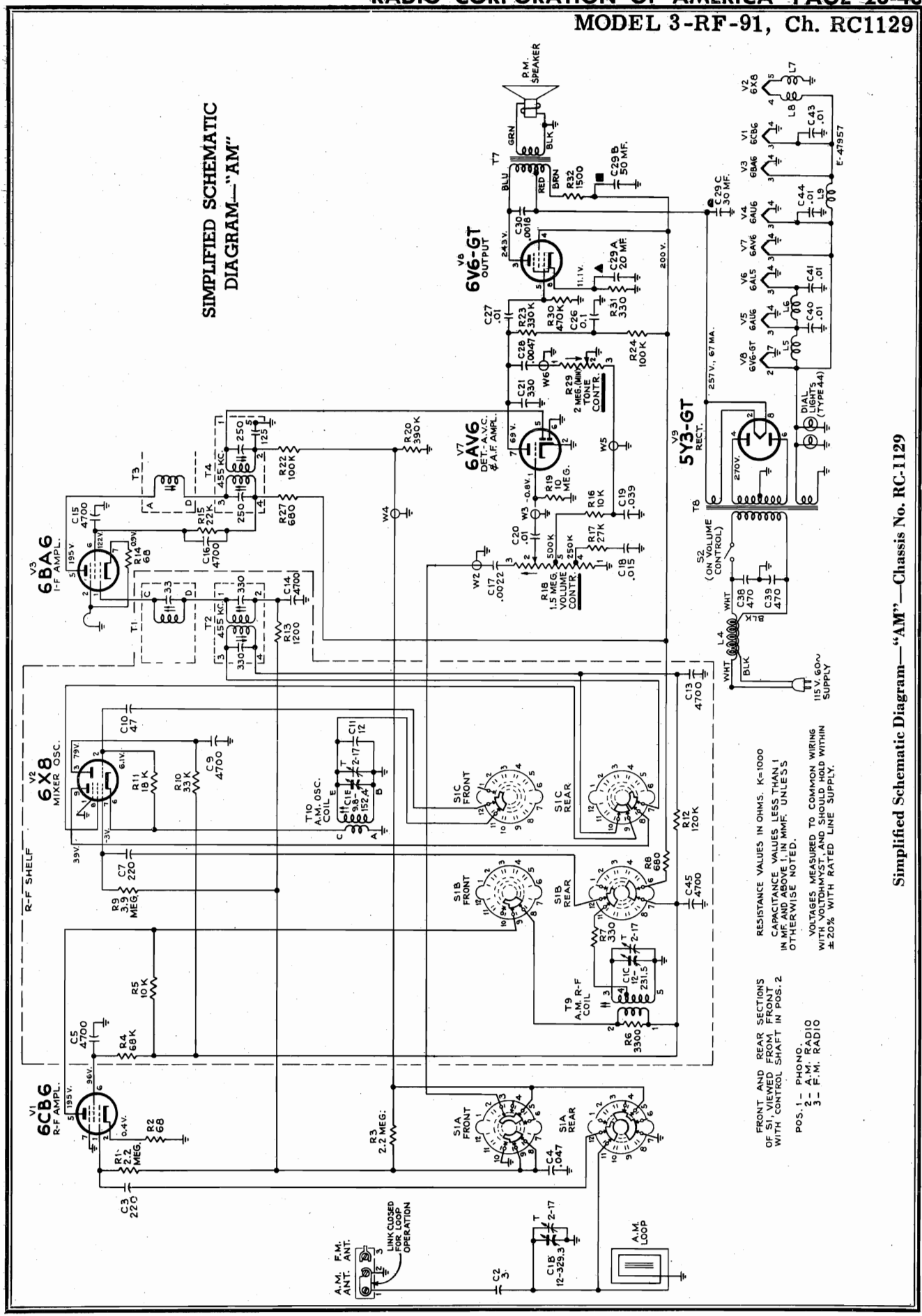

RESISTANCE VALUES IN OHMS. K=1000
 CAPACITANCE VALUES LESS THAN 1
 IN MICROFARADS UNLESS
 OTHERWISE NOTED.
 VOLTAGES MEASURED TO COMMON WIRING
 WITH VOLTOHMYST. AND SHOULD HOLD WITHIN
 ±20% WITH RATED LINE SUPPLY.

FRONT AND REAR SECTIONS
 OF S1 VIEWED FROM FRONT
 WITH CONTROL SHAFT IN POS. 2

POS. 1 - PHONO.
 2 - A.M. RADIO
 3 - F.M. RADIO

Simplified Schematic Diagram—"AM"—Chassis No. RC-1129

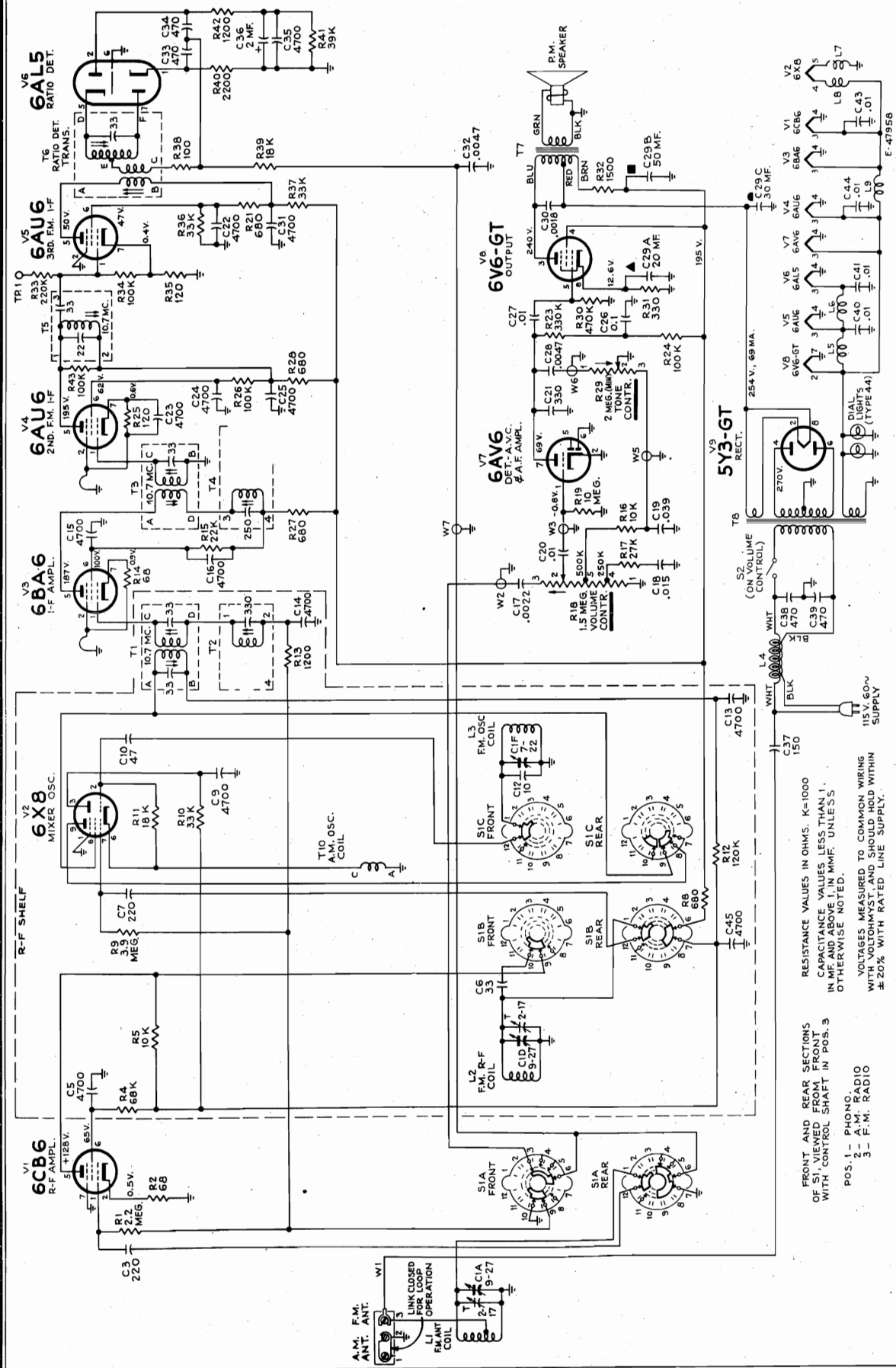

RESISTANCE VALUES IN OHMS. K=1000
 CAPACITANCE VALUES LESS THAN 1.
 IN MF AND ABOVE 1 IN MMF. UNLESS
 OTHERWISE NOTED.
 VOLTAGES MEASURED TO COMMON WIRING
 WITH VOLTOHMST. AND SHOULD HOLD WITHIN
 ± 20% WITH RATED LINE SUPPLY.

FRONT AND REAR SECTIONS
 OF SH. CONTROL SHAFT IN POS. 3
 POS. 1 - PHONO.
 2 - A.M. RADIO
 3 - F.M. RADIO

Simplified Schematic Diagram—"FM"—Chassis No. RC-1129

MODEL 3-RF-91, Ch. RC1129

STOCK No.	DESCRIPTION	STOCK No.	DESCRIPTION
CHASSIS ASSEMBLIES RC1129			
12717	Board—Antenna terminal board	503168	680 ohms, ±10%, ½ watt (R8, R21, R27, R28)
76333	Capacitor—Variable tuning capacitor (C1A, C1B, C1C, C1D, C1E, C1F)	503212	1200 ohms, ±10%, ½ watt (R13, R42)
73473	Capacitor—Fixed, ceramic, 4700 mmf., +100%, -0%, 500 volts D.C., High "K" disc (C5, C9, C14, C15, C16, C22, C23, C24, C25, C31, C35, C45)	503222	2200 ohms, ±10%, ½ watt (R40)
73960	Capacitor—Fixed, ceramic, 10,000 mmf., +100%, -0%, 500 volts D.C., High "K" disc (C40, C41, C43, C44)	503233	3300 ohms, ±10%, ½ watt (R6)
76552	Capacitor—Fixed, ceramic, insulated, 330 mmf., ±10%, 500 volts D.C., High "K" disc (C21)	503310	10,000 ohms, ±10%, ½ watt (R5, R16)
77277	Capacitor—Fixed, ceramic, non-insulated, 3 mmf., ±1 mmf., 500 volts D.C., Temp. coef. = 0 (C2)	503318	18,000 ohms, ±10%, ½ watt (R11, R39)
76350	Capacitor—Fixed, ceramic, non-insulated, 10 mmf., ±0.5 mmf., 500 volts D.C. Temp. coef. = -470 (C12)	503322	22,000 ohms, ±10%, ½ watt (R15)
76349	Capacitor—Fixed, ceramic, non-insulated, 12 mmf., ±10%, 500 volts D.C. Temp. coef. = -330 (C11)	503327	27,000 ohms, ±10%, ½ watt (R17)
70596	Capacitor—Fixed, ceramic, non-insulated, 33 mmf., ±10%, 500 volts D.C. Temp. coef. = 0 (C6)	503333	33,000 ohms, ±10%, ½ watt (R36)
39042	Capacitor—Fixed, ceramic, non-insulated, 47 mmf., ±10%, 500 volts D.C. Temp. coef. = -750 (C10)	513333	33,000 ohms, ±10%, 1 watt (R10, R37)
71920	Capacitor—Fixed, ceramic, non-insulated, 220 mmf., ±10%, 500 volts D.C. Temp. coef. = -750 (C3, C7)	503339	39,000 ohms, ±10%, ½ watt (R41)
	Capacitor—Fixed, mica:	503368	68,000 ohms, ±10%, ½ watt (R4)
39632	150 mmf., ±10%, 500 volts D.C. (C37)	503410	100,000 ohms, ±10%, ½ watt (R22, R24, R26, R34, R43)
77941	470 mmf., ±10%, 300 volts D.C. (C33, C34)	503412	120,000 ohms, ±10%, ½ watt (R12)
39644	470 mmf., ±20%, 500 volts D.C. (C38, C39)	503422	220,000 ohms, ±10%, ½ watt (R33)
39668	4700 mmf., ±20%, 500 volts D.C. (C13)	503433	330,000 ohms, ±10%, ½ watt (R23)
73747	Capacitor—Electrolytic, 2 mfd., 50 volts (C36)	503439	390,000 ohms, ±10%, ½ watt (R20)
76330	Capacitor—Electrolytic comprising 1 section of 30 mfd., 350 volts, 1 section of 50 mfd., 300 volts, and 1 section of 20 mfd., 25 volts (C29A, C29B, C29C)	503447	470,000 ohms, ±10%, ½ watt (R30)
	Capacitor—Fixed, tubular, paper:	503522	2.2 megohm, ±10%, ½ watt (R1, R3)
77942	0.0022 mfd., 200 volts (C17)	503539	3.9 megohm, ±10%, ½ watt (R9)
73920	0.0047 mfd., 600 volts (C28, C32)	503610	10 megohm, ±10%, ½ watt (R19)
77424	0.01 mfd., 200 volts (C20)	76339	Shaft—Tuning knob shaft
73561	0.01 mfd., 400 volts (C27)	73584	Shield—Tube shield for V2
77943	0.015 mfd., 200 volts (C18)	76331	Shield—Tube shield for V1, V6
77989	0.039 mfd., 200 volts (C19)	35574	Socket—Dial lamp socket
73558	0.047 mfd., 200 volts (C4)	73117	Socket—Tube socket, 7 pin, miniature, wafer for V1 and V7
73551	0.1 mfd., 400 volts (C26)		
73851	0.0018 mfd., 1600 volts, oil impregnated (C30)	77937	Socket—Tube socket, 7 pin, miniature, wafer for V3, V4, V5, V6
73935	Clip—Mounting clip for I.F. transformer	70827	Socket—Tube socket, octal, wafer for V8, V9
76354	Coil—Antenna coil—F.M. (L1)	76336	Socket—Tube socket, 9 pin, miniature, saddle mounted for V2
71942	Coil—Filament choke coil (L5, L6, L9)	76332	Spring—Drive cord spring
76351	Coil—Filament choke coil (L7, L8)	76334	Switch—Function switch (S1)
76337	Coil—Oscillator coil—A.M.—complete with adjustable core (T10)	76335	Transformer—First I.F. transformer—A.M. (T2)
77973	Coil—Oscillator coil—F.M. (L3)	75559	Transformer—First I.F. transformer—F.M. (T1)
76338	Coil—R.F. coil—A.M.—complete with adjustable core (T9)	76328	Transformer—Second I.F. transformer—A.M. (T4)
		76329	Transformer—Second I.F. transformer—F.M. (T3)
76353	Coil—RF coil—F.M. (L2)	77939	Transformer—Third I.F. transformer—F.M.—complete with adjustable core (T5)
35787	Connector—Phono input connector (J1)	77940	Transformer—Output transformer (T7)
76460	Contact—Test point contact (TP1)	76326	Transformer—Power transformer, 117 volts, 60 cycle (T8)
77936	Control—Tone control (R29)	77938	Transformer—Ratio detector transformer complete with adjustable core (T6)
70342	Control—Volume control and power switch (R18, S2)	33726	Washer—"C" washer for station selector pointer shaft and pulley and for tuning knob shaft
72953	Cord—250' Drive cord reel—approx. 50" overall required	SPEAKER ASSEMBLIES 92586-8-W RMA-274	
70392	Cord—Power cord and plug	75024	Cone—Cone and voice coil (3.2 ohms)
74839	Fastener—Push fastener for mounting RF shelf	74664	Speaker—8" P.M. speaker complete with cone and voice coil (3.2 ohms)
74838	Grommet—Power cord strain relief (1 set)	MISCELLANEOUS	
16058	Grommet—Rubber grommet for RF shelf (4 required)	76343	Antenna—Ferrite rod antenna complete with coil less masonite support and grommets
11891	Lamp—Dial lamp—Mazda 44	76359	Back—Cabinet back
76340	Pan—Speaker pan assembly complete less station selector pointer shaft and pulley	77944	Bezel—Decorative bezel—round—for front of cabinet
76341	Pulley—Station selector pointer shaft and pulley	Y2519	Cabinet—Plastic cabinet less decals
52436	Resistor—Fixed, wire wound, 1500 ohms, 4 watts (R32)	76678	Clip—Mounting clip for cabinet back (4 required)
	Resistor—Fixed, composition:	76767	Decal—Control function decal
503068	68 ohms, ±10%, ½ watt (R2, R14)	76356	Dial—Polystyrene dial scale
503110	100 ohms, ±10%, ½ watt (R38)	77033	Emblem—"RCA Victor" emblem
503112	120 ohms, ±10%, ½ watt (R25, R35)	77950	Grommet—Rubber grommet for mounting ferrite rod antenna to masonite support (2 required)
503133	330 ohms, ±10%, ½ watt (R7)	77951	Insert—Hard rubber insert for antenna mounting grommets (2 required)
513133	330 ohm, ±10%, 1 watt (R31)	77232	Knob—Function switch knob—maroon
		77233	Knob—Tuning control, tone control or volume control and power switch knob—maroon
		77947	Nameplate—"AM-FM" nameplate
		72765	Nut—Speed nut to fasten bezel to cabinet (4 required)
		73203	Nut—Speed nut to fasten "RCA Victor" or "AM-FM" emblems to cabinet
		77948	Pointer—Station selector pointer
		77945	Reflector—Dial scale reflector
		77946	Screen—Grille screen
		74734	Spring—Spring clip for control knobs
		77949	Support—Antenna support (masonite) only

APPLY TO YOUR RCA DISTRIBUTOR FOR PRICES OF REPLACEMENT PARTS

MODELS 2C511, 2C512,
2C513, 2C514, Ch. RC1118



2C511 2C512 2C513 2C514
Black & Gray Ivory Red Two Tone Gray

SPECIFICATIONS

Tuning Range 540-1600 kc
Intermediate Frequency 455 kc
Tube Complement:
(1) RCA 12BE6 Converter
(2) RCA 6BJ6 I.F. Amplifier
(3) RCA 12AV6 Det.-AVC-A.F. Amp.
(4) RCA 6AK6 Output
RCA Stock No. 77292 Rectifier
Power Supply Rating:
115 volts a.c., 60 cycles 20 watts
CAUTION: DO NOT OPERATE ON D.C.

Loudspeaker:
Size and type 3 in. P.M.
Voice Coil impedance 3.2 ohms at 400 cycles
Power Output:
Undistorted 0.19 watts
Maximum 0.35 watts
Tuning Drive Ratio 1 to 1 (Direct Drive)
Weight 4½ lbs.
Dimensions (overall):
Height...6" Width...8½" Depth...4½"

OPERATING INSTRUCTIONS

This instrument contains a timer-type electric clock mechanism which may be used to automatically actuate the self-contained a.c. radio. The radio may also be operated independently of the clock mechanism.

CLOCK—1. Plug instrument into 115 v. a.c. outlet. The clock will start to operate immediately. Set the correct time by turning clockwise, the "TIME" knob located at the center of the instrument back. To set the alarm, turn the "ALARM" knob clockwise until the desired time is indicated by the alarm pointer extension on the hour hand. Pull knob out for alarm buzzer operation. To turn off buzzer, push knob in.

RADIO—1. To obtain radio operation independently of the clock, push the slide switch lever at the top of the cabinet to the left "ON" position. Adjust volume and tuning control knobs as required after approximately 30 second warm-up. To increase volume turn knob clockwise as viewed from volume control side panel. Push slide switch lever to the center "OFF" position when finished listening.

2. To automatically actuate the radio by the clock mechanism, make initial volume and station settings as described in section 1 above. Set the "ALARM" knob to the time desired. Push slide switch lever to the right "AUTO" position. If the alarm buzzer knob is pulled out, the alarm will sound approximately ten minutes after the radio starts operating. Push alarm knob in to turn off alarm. The radio will turn itself off after a period of approximately one hour if the slide switch remains in the "AUTO" position after start of playing.

CAUTION—Keep slide switch "ON-OFF-AUTO" lever in "OFF" position when instrument is not in use. Locate instrument so that "TIME" and "ALARM" knobs have free movement.

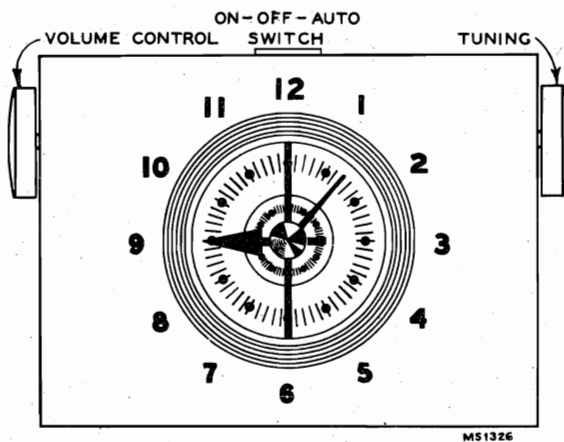

Clock Radio Controls

ALIGNMENT PROCEDURE

Output Meter Alignment—If this method is used, connect the meter across the voice coil and turn the receiver volume control to maximum.

Test-Oscillator—For all alignment operations, connect the low side of the test-oscillator to the receiver chassis, and keep the oscillator output as low as possible to avoid AVC action.

On a.c. operation an isolation transformer (115 v./115 v.) may be necessary for the receiver if the test oscillator is also a.c. operated.

ALIGNMENT TABULATION

Step	Connect the high side of test-oscillator to—	Tune test-osc. to—	Turn radio dial to—	Adjust the following for max. output
1	6BJ6 I-F grid through .01 mfd. capacitor	455 kc	Quiet-point 1600 kc end of dial	T2 (top and bottom) 2nd I-F trans.
2	Stator of C1-A through .01 mfd.			T1 (top and bottom) 1st I-F trans.
3		1620 kc	Min. cap.	osc. trimmer C1B-T
4	Short wire placed near loop to radiate signal	1400 kc	1400 kc signal	ant. trimmer C1A-T
5		600 kc	600 kc (rock)	(osc. coil) Slug L3
6		Repeat steps 3, 4, and 5		

RADIO CHASSIS AND CLOCK SERVICE

TOOL REQUIREMENTS—A small #1 size cross-head screwdriver is required for disassembly of the radio into its major cabinet and chassis components.

TUBE SERVICE—Disassembly—To make tubes accessible for testing, remove the volume and tuning control knobs by pulling off. Unscrew counterclockwise the alarm and time knobs from their shafts. Invert the cabinet and remove only the two cross-head screws along the back underside of the cabinet. Place the cabinet in its normal position. Using only firm hand pressure, press down alternately at front right and left sides of the cabinet top, midway between the "ON-OFF-AUTO" slide switch lever and the cabinet sides, forcing down and backward, to disengage the molded-in plastic catches. Then lift off the cabinet rear cover.

Assembly—To reassemble, proceed in the reverse order, sliding the cabinet rear cover into its track on the cabinet base. Lift the front corners up slightly to clear the two molded-in pads at each front corner of the cabinet base. Then press down and snap-in the upper front edge of the cabinet rear cover under the top rim of the cabinet base. Make sure the slide switch and switch lever are in corresponding center "OFF" positions. Reassemble clock and radio knobs, and the two screws securing the cabinet rear cover.

RADIO CHASSIS SERVICE—Disassembly—To service chassis, open case as described above. In addition, remove the single cross-head screw remaining at the front underside of the cabinet and also the two cross-head screws located on the chassis near the tuning gang and the volume control. Lift out the chassis and remove the four self-tapping cross-head screws holding the bottom cover to the chassis. Lift off the bottom cover.

Assembly—Reassemble in the reverse order. Secure the bottom cover to the chassis with the four self-tapping screws. Next, insert the single self-tapping screw holding the chassis to the bottom of the cabinet base. Center the chassis mounting holes so that they line up with the holes in the cabinet and replace the two cross-head machine screws. Tighten just sufficiently to hold the chassis firmly. Do not turn the screws to the possible limit of travel unless this is necessary to hold the chassis firmly. The average receiver may have a 1/32" clearance between the chassis

metal panel and molded plastic boss. If any of the four foam rubber cushions on the bottom cover register in the clock face after assembly, push the excess length under the "Z" tabs of the bottom cover.

CLOCK SERVICE—Disassembly—To service clock, remove chassis and bottom cover as described above. In addition, remove the three screws holding the speaker to the speaker mounting bracket. Remove the two hex nuts holding the clock to the chassis pan recess. Lift the clock out. Unsolder the clock leads at the clock terminals.

Assembly—Proceed in the reverse order. Solder clock leads, and secure clock to chassis pan with two hex head nuts. Reassemble speaker to speaker mounting bracket.

CRITICAL LEAD DRESS

1. Filament leads should be dressed away from secondary output lead, terminal #1, of 2nd I.F. Transformer and secondary output lead, terminal #1, of 1st I.F. transformer.
2. Connect the outside foil of capacitors as shown on schematic.
3. Dress electrolytic capacitor leads and filament transformer leads away from selenium rectifier.
4. Plate and grid leads of 12BE6 and 6BJ6 tubes should be kept as short and direct as possible.

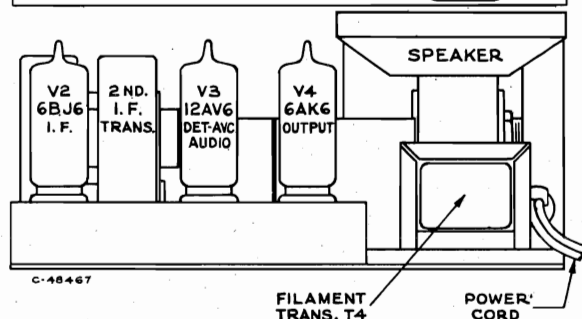
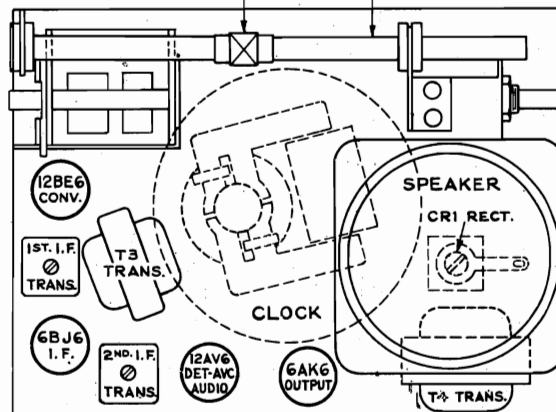
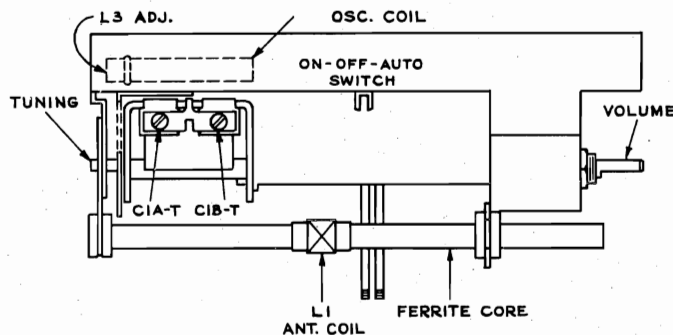

Tube and Trimmer Locations

MODELS 2C511, 2C512,
2C513, 2C514, Ch. RC1118

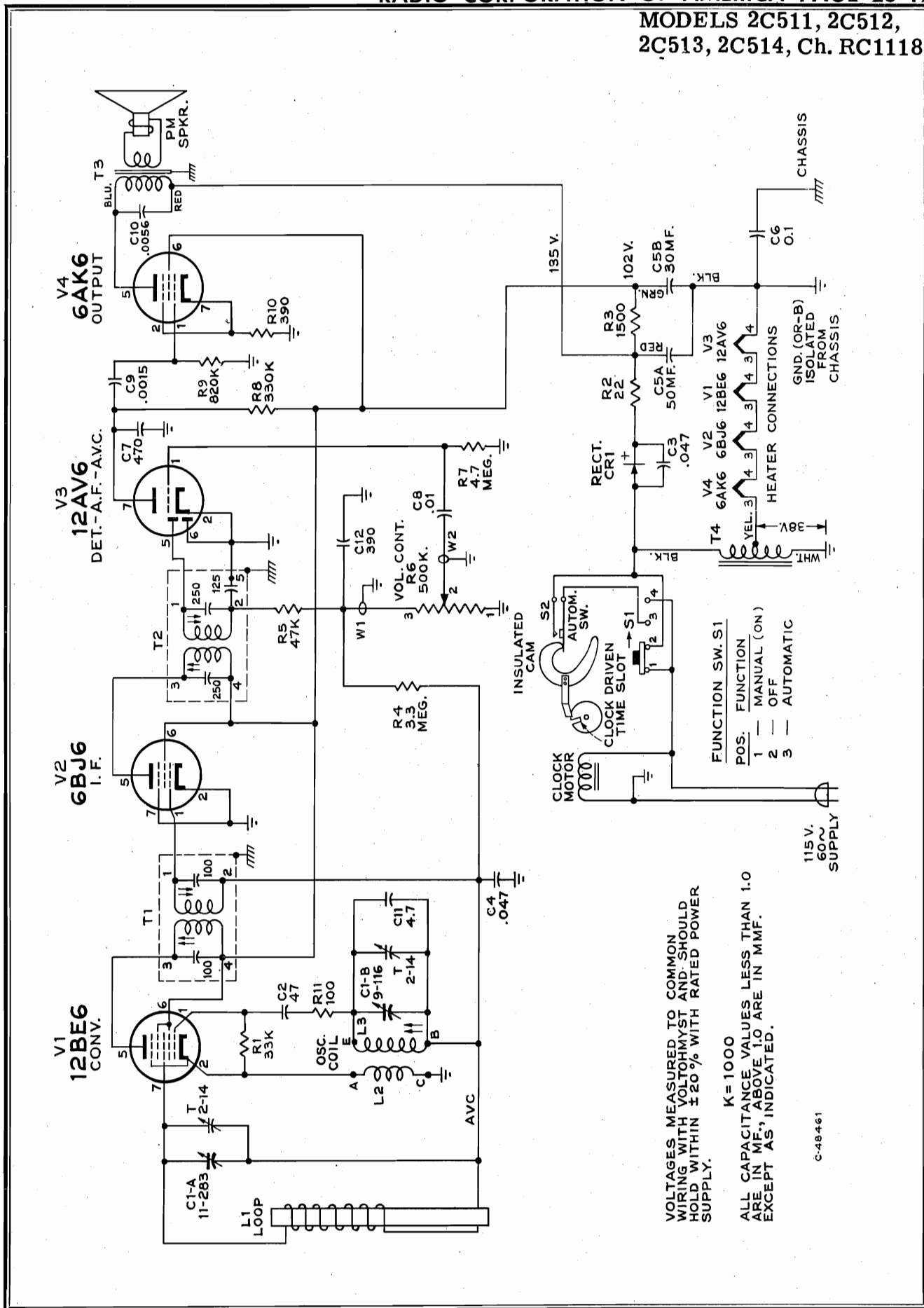

VOLTAGES MEASURED TO COMMON WIRING WITH VOLTHMYSST AND SHOULD HOLD WITHIN ±20% WITH RATED POWER SUPPLY.

K = 1000

ALL CAPACITANCE VALUES LESS THAN 1.0 ARE IN MF., ABOVE 1.0 ARE IN MMF. EXCEPT AS INDICATED.

C-48461

MODELS 2C511, 2C512,
2C513, 2C514, Ch. RC1118

STOCK NO.	DESCRIPTION	STOCK NO.	DESCRIPTION
CHASSIS ASSEMBLIES			
	RC 1118—Model 2C511 RC 1118A—Model 2C512	77414	Transformer—Output transformer T3
	RC 1118B—Model 2C513 RC 1118C—Model 2C514	77416	Transformer—1st. I.F. transformer complete with adjustable cores T1
77410	Antenna—Ferrite rod antenna complete with windings L1	77417	Transformer—2nd. I.F. transformer complete with adjustable cores T2
77408	Capacitor—Variable tuning capacitor... C1A, C1B	77420	Washer—Shoulder washer (nylon) for variable tuning capacitor mounting (3 req'd)
77471	Capacitor—Ceramic, 4.7 mmf. C11	SPEAKER ASSEMBLIES	
75609	Capacitor—Ceramic, 47 mmf. C2	971920-1	
75641	Capacitor—Ceramic, 390 mmf. C12	77428	Speaker—3" P.M. speaker complete with cone and voice coil (3.2 ohms)
75198	Capacitor—Ceramic, 470 mmf. C7	MISCELLANEOUS	
77427	Capacitor—Electrolytic comprising 1 section of 50 mfd., 150 volts and 1 section of 30 mfd., 150 volts C5A, C5B	77430	Back—Polystyrene cabinet back—gray tan—for Model 2C511
77425	Capacitor—Tubular, paper, .0015 mfd., 200 volts C9	77505	Back—Polystyrene cabinet back—ivory—for Model 2C512
77488	Capacitor—Tubular, paper, .0056 mfd., 400 volts C10	77507	Back—Polystyrene cabinet back—red—for Model 2C513
77424	Capacitor—Tubular, paper, .01 mfd., 200 volts... C8	77509	Back—Polystyrene cabinet back—gray—for Model 2C514
77422	Capacitor—Tubular, paper, .047 mfd., 400 volts... C4	77433	Button—Slide button for function switch less clip
75071	Capacitor—Tubular, moulded, .047 mfd., 400 volts C3	77429	Case—Polystyrene case front—black—complete with window less back for Model 2C511
77423	Capacitor—Tubular, paper, 0.1 mfd., 400 volts... C6	77504	Case—Polystyrene case front—ivory—complete with window less back for Model 2C512
77421	Clip—"C" clip for mounting speaker	77506	Case—Polystyrene case front—red—complete with window less back for Model 2C513
75010	Clip—"C" clip for mounting output transformer	77508	Case—Polystyrene case front—gray—complete with window less back for Model 2C514
73935	Clip—Mounting clip for I.F. transformer	77434	Clip—Spring clip for function switch slide button
77411	Coil—Oscillator coil complete with adjustable core L2, L3	77431	Dial—Dial knob—gray tan—for Model 2C511
77409	Control—Volume control R6	77498	Dial—Dial knob—ivory—for Model 2C512
70392	Cord—Power cord and plug	77499	Dial—Dial knob—red—for Model 2C513
77404	Cover—Chassis bottom cover	77500	Dial—Dial knob—gray—for Model 2C514
77419	Cushion—Foam rubber cushion for speaker rim or bottom cover	77432	Knob—Volume control knob—gray tan—for Model 2C511
74838	Grommet—Power cord strain relief (1 set)	77501	Knob—Volume control knob—ivory—for Model 2C512
77418	Grommet—Rubber grommet for mounting ferrite rod antenna	77502	Knob—Volume control knob—red—for Model 2C513
77405	Insulator—Bakelite insulator for variable tuning capacitor	77503	Knob—Volume control knob—gray—for Model 2C514
77406	Insulator—Ferrite rod antenna mounting insulator—L.H.	77412	Knob—Timer knob
77407	Insulator—Ferrite rod antenna mounting insulator—R.H.	77437	Screw—#6 x 3/16" cross recessed truss head tapping screw for mounting chassis
77292	Rectifier—Selenium rectifier CR1	77436	Screw—#6-32 x 3/16" cross recessed truss head machine screw for mounting chassis to case
	Resistor—Fixed, composition:—	77435	Screw—#6-32 x 3/16" cross recessed truss head machine screw for fastening case assembly
503022	22 ohms, ±10%, 1/2 watt R2	74734	Spring—Spring clip for dial knob or volume control knob
503110	100 ohms, ±10%, 1/2 watt R11	77467	Washer—Knob Washer—felt
503139	390 ohms, ±10%, 1/2 watt R10	CLOCK ASSEMBLY	
532215	1500 ohms, ±10%, 2 watts R3	* * *	
503333	33,000 ohms, ±10%, 1/2 watt R1	Clock—If clock mechanism repair becomes necessary, remove the clock from the radio. The RCA Victor Distributor in your area will advise you of the address of the nearest authorized service station for clock mechanisms. Repair facilities and replacement parts are available at these authorized service stations.	
503347	47,000 ohms, ±10%, 1/2 watt R5		
503433	330,000 ohms, ±10%, 1/2 watt R8		
503482	820,000 ohms, ±10%, 1/2 watt R9		
503533	3.3 megohm, ±10%, 1/2 watt R4		
503547	4.7 megohm, ±10%, 1/2 watt R7		
75780	Socket—Tube socket, 7 pin. miniature, saddle mounted		
77415	Switch—Function switch S1		
77413	Transformer—Filament transformer 117 volts A.C. input T4		

APPLY TO YOUR RCA DISTRIBUTOR FOR PRICES OF REPLACEMENT PARTS

MODEL 2-X-621,
Ch. RC1085B

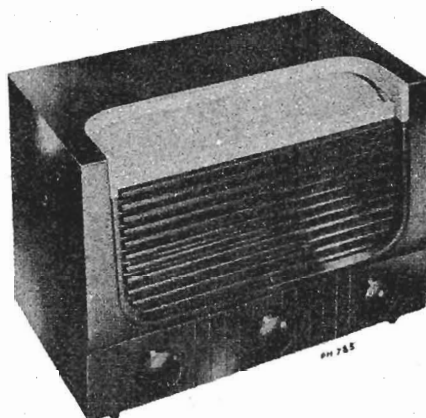

Specifications

Tuning Ranges

Standard Broadcast ("A" Band)..... 540-1600 kc
Short Wave ("C" Band)..... 5.8-18.0 mc

Intermediate Frequency 455 kc

Tube Complement

- (1) RCA 12BA6 R. F. Amplifier
- (2) RCA 12BE6 Converter
- (3) RCA 12BA6 I. F. Amplifier
- (4) RCA 12SQ7 Det. - A.F. - A.V.C.
- (5) RCA 35L6GT Output
- (6) RCA 35Z5 Rectifier

Dial Lamp 2 Type 1490, 3.2 volts, 0.15 amp.

Power Supply Rating

115 volts, D.C. or 50 to 60 cycles, A.C..... 35 watts

Loudspeaker

Type 971495-9W 4 in. P.M.
V. C. Impedance..... 3.2 ohms at 400 cycles

Power Output

Undistorted 0.85 watts
Maximum 1.2 watts

Weight

..... 8 lbs.

Cabinet Dimensions

Height... 8 $\frac{5}{8}$ in. Width... 11 $\frac{3}{4}$ in. Depth... 7 $\frac{1}{2}$ in.

Tuning Drive Ratio..... 11:1 (5 $\frac{1}{2}$ turns of knob)

NOTE: If reception is not obtained on DC, reverse plug in outlet receptacle. This may also reduce hum on AC operation.

Operating Instructions

Radio—Turn power on with POWER-VOLUME control and set about half-way for volume. Set the FUNCTION Control for the type of program desired and allow 30 to 40 second warm-up period when the dial will be fully illuminated.

Tune in desired station with TUNING Control making slow and careful setting in conjunction with volume control for Short Wave reception. Make final setting of VOLUME control to suit requirements.

Phonograph Operation—Plug in record changer attachment to phono socket on lower chassis apron. Set FUNCTION switch to "PH" (phono) position. Adjust VOLUME control for listening requirements.

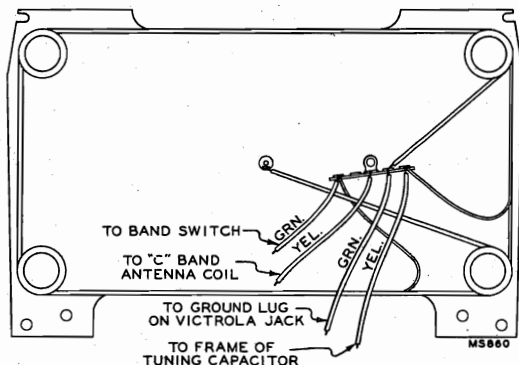

Loop Antenna Leads

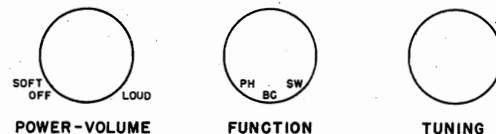
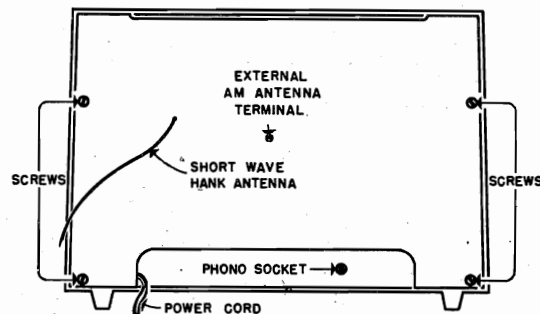

Radio Controls

MODEL 2-X-621, Ch. RC1085B

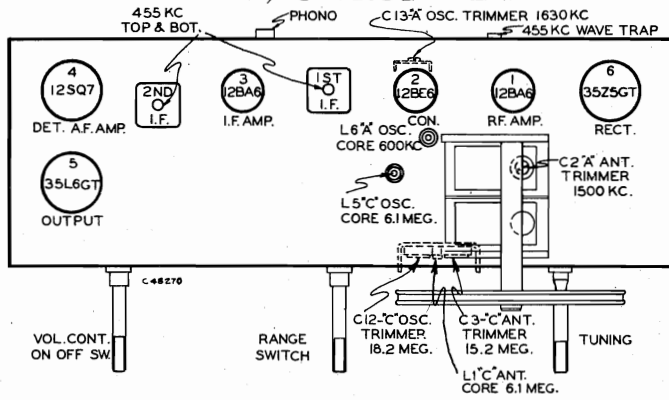

Tube and Trimmer Locations

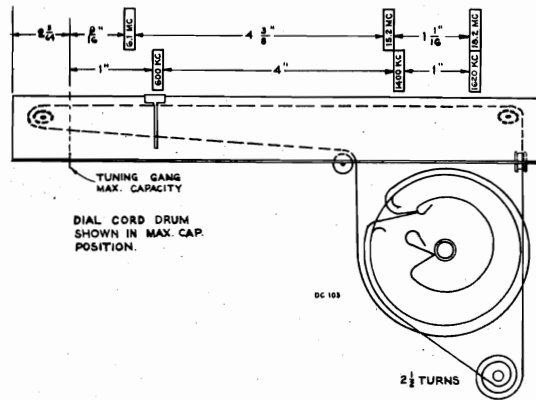

Dial Indicator and Drive Mechanism

ALIGNMENT PROCEDURE

Steps	Connect the High Side of The Test Osc. to—	Tune Test Osc. to—	Range Switch to—	Turn Radio Dial to—	Adjust for maximum output
1	Pin No. 1 of 12BA6 I.F. amp. tube in series with 0.1 mfd.	455 kc.	"A"	Quiet Point near 1600 kc.	Top and bottom T2 2nd I.F. Trans.
2	Pin No. 7 of 12BE6 Converter tube in series with 0.1 mfd.				*Top and bottom T1 1st I.F. Trans.
3	Pin No. 1 of 12BA6 R.F. tube in series with 0.1 mfd.				L2 wave trap for minimum output.
4	(Radiated signal) short piece of wire placed near ant.	1620 kc.	"A"	1620 kc. (Cap. min.)	C-13 "A" Osc.
5		1400 kc.		1400 kc.	C-2 "A" ant.
6		600 kc.		600 kc.	L6 "A" Osc. Rocking gang.
7	Repeat steps 4, 5 and 6.				
8	Center terminal on loop antenna Term. board through 47 mfd. Low side to loop primary terminal	18.2 mc.	"C"	18.2 mc. (Min. cap.)	**C-12 "C" Osc.
9		15.2 mc.		15.2 mc.	***+C-3 "C" Ant.
10		6.1 mc.		6.1 mc.	††L-5 "C" Osc. L-1 "C" Ant.
11	Repeat steps 8, 9, and 10 as necessary.				

*Use 18K resistor across primary when aligning secondary, across secondary when aligning primary.

**Two peaks should be found, use one having lowest capacity.

***Two peaks should be found, use one having highest capacity. Note: Check for image frequencies.

†Radio dial tuned to 15.2 mc. as in step 9, tune test osc. to 16.11 mc. where a weaker signal should be heard.

††Radio dial tuned to 6.1 mc. as in step 10, tune test osc. to 7.01 mc. where a weaker signal should be heard.

Test Oscillator—Connect low side of test oscillator to common wiring in series with a .1 mf. capacitor. If the test oscillator is a c. operated it may be necessary to use an isolation transformer for the receiver during alignment and the low side of the test oscillator connected directly to common wiring at the electrolytic capacitor. Keep the oscillator output low to prevent a-v-c action.

Output Meter Alignment—If this method is used, connect the meter across the voice coil and turn the receiver volume control to maximum.

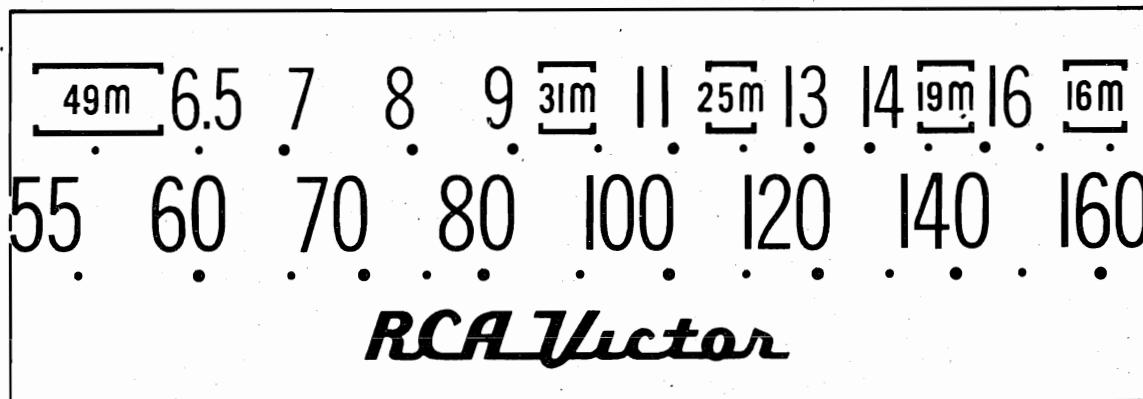

MAX. CAP.

Dial Scale Actual Size

CRITICAL LEAD DRESS

1. Dress all heater leads and pilot light leads down to chassis and away from all audio grid and plate wiring.
2. Dress all exposed leads away from each other and away from chassis to prevent short circuits.
3. Leads to loop antenna are long and draped to permit tube servicing by lowering loop back. They should be evenly spaced to maintain low capacity and dressed to prevent touching gang plates.
4. All R.F. leads to coils should be short and direct. Dress other leads and components away from coils.

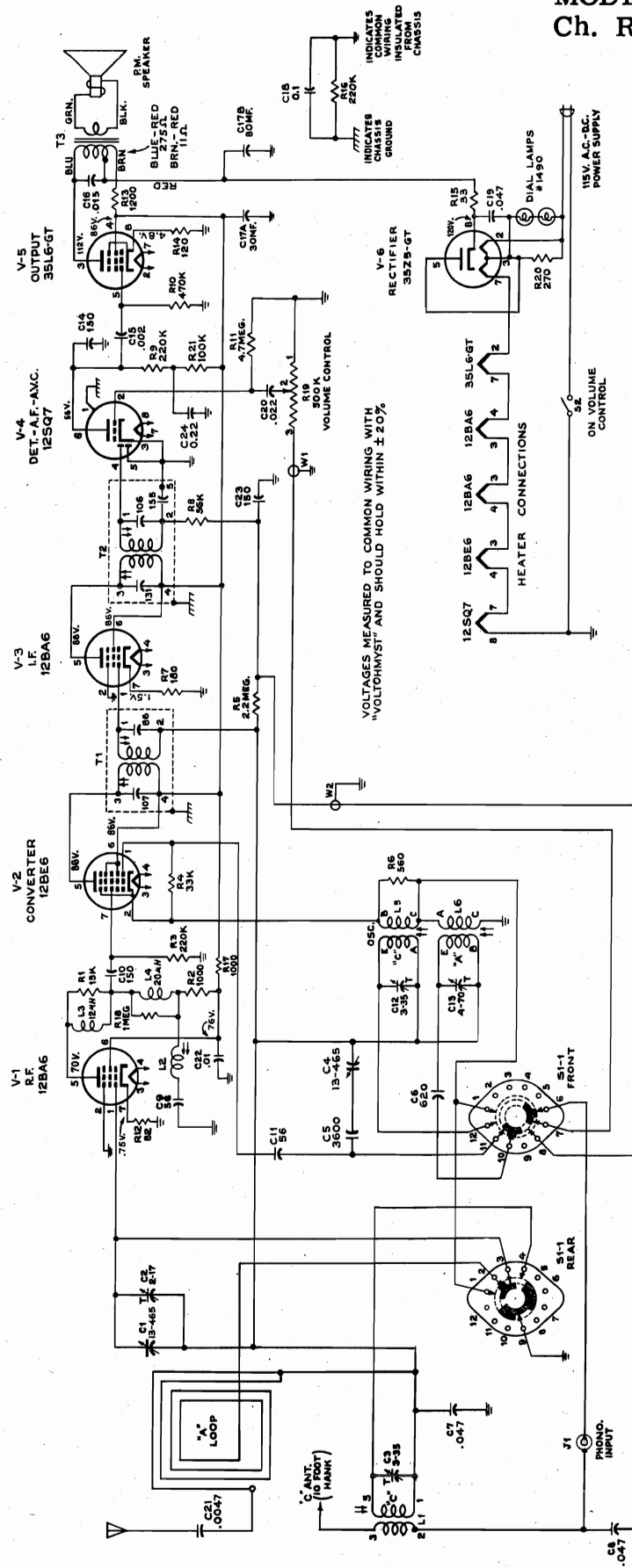

VOLTAGES MEASURED TO COMMON WIRING WITH "VOLTOHMYST" AND SHOULD HOLD WITHIN ±2.0%

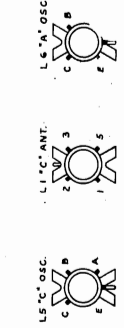

FRONT AND REAR SECTION OF S1-1 VIEWED FROM FRONT WITH THE CONTROL SHAFT IN EXTREME C/CLOCKWISE POSITION #1 (PHONO).

POS.	S1-1 SEQUENCE	FUNCTION
1	1	PHONO
2	2	AM BAND
3	3	FM BAND
4	4	AM BAND
5	5	C BAND

D-46823

MODEL 2-X-621,
Ch. RC1085B

STOCK NO.	DESCRIPTION	STOCK NO.	DESCRIPTION
	CHASSIS ASSEMBLIES RC-1085B		Resistor—Fixed, composition:—
77217	Antenna—Antenna loop and back cover—maroon	514033	33 ohms, ±20%, 1 watt.....R15
77217	Back—Cabinet back cover and antenna loop assembly—maroon	503082	82 ohms, ±10%, ½ watt.....R12
71042	Button—Plug button for trimmer adjustment hole	503112	120 ohms, ±10%, ½ watt.....R14
77216	Capacitor—Variable tuning capacitor complete with drive drum.....C1, C2, C4	503118	180 ohms, ±10%, ½ watt.....R7
74924	Capacitor—Mica trimmer, dual 3-35 mmf.....C3, C12	503127	270 ohms, ±10%, ½ watt.....R20
74923	Capacitor—Mica trimmer, 4-70 mmf.....C13	503156	560 ohms, ±10%, ½ watt.....R6
71924	Capacitor—Ceramic, 56 mmf.....C9, C11	503210	1000 ohms, ±10%, ½ watt.....R2, R17
73501	Capacitor—Ceramic, 150 mmf.....C10, C14, C23	513212	1200 ohms, ±10%, 1 watt.....R13
38831	Capacitor—Mica, 620 mmf.....C6	503333	33,000 ohms, ±10%, ½ watt.....R4
39665	Capacitor—Mica, 3600 mmf.....C5	503356	56,000 ohms, ±10%, ½ watt.....R8
73473	Capacitor—Ceramic, 4700 mmf.....C21	503410	100,000 ohms, ±10%, ½ watt.....R21
72312	Capacitor—Electrolytic comprising 1 section of 30 mfd., 150 volts and 1 section of 80 mfd., 150 volts C17A, C17B	503422	220,000 ohms, ±10%, ½ watt.....R3, R9, R16
73595	Capacitor—Tubular, paper, .0022 mfd., 600 volts.....C15	503447	470,000 ohms, ±10%, ½ watt.....R10
73561	Capacitor—Tubular, paper, .01 mfd., 400 volts.....C22	504522	2.2 megohm, ±20%, ½ watt.....R5
73797	Capacitor—Tubular, paper, .015 mfd., 600 volts.....C16	504547	4.7 megohm, ±20%, ½ watt.....R11
73562	Capacitor—Tubular, paper, .022 mfd., 400 volts.....C20	74922	Shaft—Tuning knob shaft
73553	Capacitor—Tubular, paper, .047 mfd., 400 volts C7, C8, C19	74697	Socket—Dial lamp socket
73551	Capacitor—Tubular, paper, 0.1 mfd., 400 volts.....C18	73117	Socket—Tube socket, 7 pin, miniature for V1, V2, V3
73794	Capacitor—Tubular, paper, 0.22 mfd., 400 volts.....C24	54414	Socket—Tube socket, octal, saddle-mounted for V4, V5, V6
73935	Clip—Mounting clip for I.F. transformer	76368	Spring—Drive cord spring
74927	Coil—Antenna coil—"C" band.....L1	74921	Switch—Selector switch.....S1
74925	Coil—Oscillator coil—"A" band—complete with adjustable core.....L6	74918	Transformer—First I.F. transformer complete with adjustable cores.....T1
74926	Coil—Oscillator coil—"C" band—complete with adjustable core.....L5	73037	Transformer—Second I.F. transformer complete with adjustable cores.....T2
74930	Coil—Peaking coil (12 muh.).....L3, R1	73976	Transformer—Output transformer.....T3
72618	Coil—Peaking coil (20 muh.).....L4, R18	35969	Washer—"C" washer for tuning knob shaft
74928	Coil—Series wavetrap coil (455 KC) complete with adjustable core.....L2		SPEAKER ASSEMBLIES 971495-9W
35787	Connector—Phono input connector.....J1	77218	Speaker—4" P.M. speaker complete with cone and voice coil (3.2 ohms)
75474	Connector—Single contact male connector for output transformer leads (2 req'd.)		MISCELLANEOUS
38410	Control—Volume control and power switch.....R19, S2	Y2447	Cabinet—Plastic cabinet—maroon—complete with dial escutcheon
72953	Cord—250' Drive Cord Reel (approx. 50" req'd.)	77220	Dial—Polystyrene dial scale
70392	Cord—Power cord and plug	77241	Escutcheon—Dial escutcheon
74838	Grommet—Power cord strain relief (1 set)	75761	Grommet—Rubber grommet for mounting speaker (4 req'd.)
33139	Grommet—Rubber grommet for chassis base	77219	Knob—Selector switch knob—maroon
16058	Grommet—Rubber grommet for mounting tuning capacitor	74931	Knob—Tuning control or volume control and power switch knob—maroon
70980	Lead—Antenna lead—"C" band	71116	Lamp—Dial lamp—Mazda 1490
77142	Pointer—Station selector pointer	74301	Screw—#8 x ¾" cross recessed binder head screw for mounting dial
		30900	Spring—Retaining spring for knobs

APPLY TO YOUR RCA DISTRIBUTOR FOR PRICES OF REPLACEMENT PARTS

MODEL 2-S-7,
Ch. RC1117D

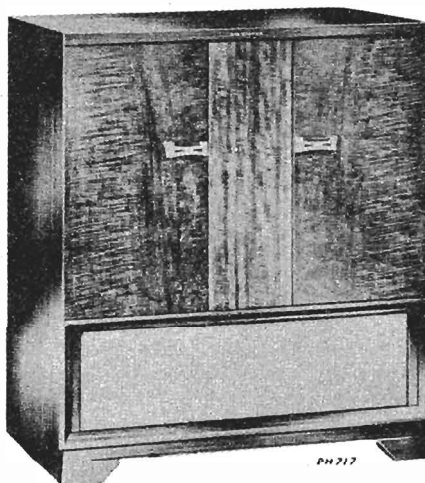

SPECIFICATIONS

Tuning Range 540 - 1600 kc.

Intermediate Frequency 455 kc.

Tube Complement

- 1. RCA 12BE6 Converter
 - 2. RCA 12BA6 I.F. Amplifier
 - 3. RCA 6AQ6 Detector—A.F. Amplifier
 - 4. RCA 6AQ6 Phase Inverter
 - 5. RCA 35C5 } Push Pull Output
 - 6. RCA 35C5 }
- A selenium rectifier Stock #76871 is used.

Power Supply Rating

115 volts A.C., 60 cycles 45 watts

Dial Lamps (2) Mazda type 51, 6-8 volts, 0.2 amp.

Loudspeaker

Size and type 8" P.M.
Voice coil impedance 3.2 ohms at 400 cycles

Power Output

At 10% distortion 2.0 watts
Maximum 2.9 watts

Cabinet Dimensions

Height 32 1/4" Width 28 1/2" Depth 19 1/8"

Tuning Drive Ratio 14 1/4:1 (7 1/8 turns of knob)

Record Changer (930409-5, or -10)

Turntable speed 33 1/2, 45 or 78 r.p.m.
Record capacity up to fourteen 7 inch RCA type
or twelve 10 inch
or ten 12 inch
or ten 10 in. and 12 in. intermixed.

Pickup (Stock No. 75475) .. Crystal with replaceable styli.

Weight 66 lbs. net

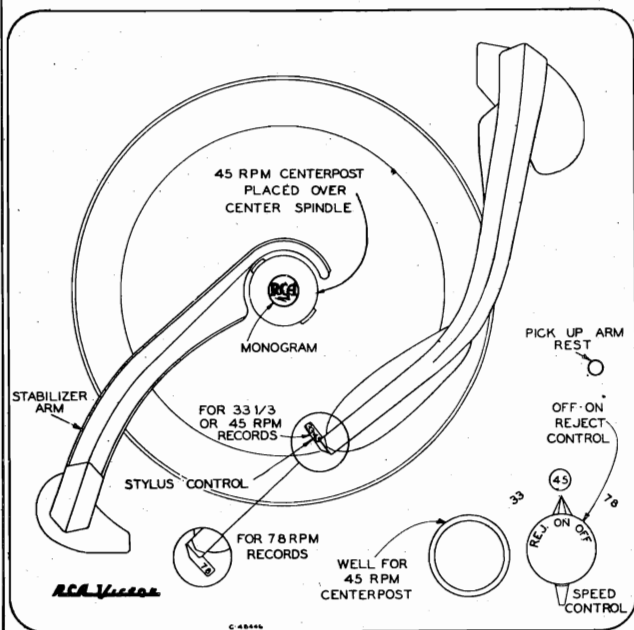

Record Changer Controls

RECORD CHANGER CONTROLS

The record changer has a dual control on the motorboard and a stylus selector control on the pickup arm. The inner control (circular knob) is the OFF-ON-REJECT control. Turning this knob to the center position energizes the motor and starts the turntable, when turned to the right (clockwise) it starts the mechanism into complete automatic operation. The mechanism will shut off automatically after the last record has been played but can be shut off manually by turning this knob to the left (counter-clockwise).

The outer control (double ended lever) is the speed control. It has three normal positions, "33", "45", "78" to select the turntable speed desired and a neutral position (midway between "45" and "78"). The control should be turned to this neutral position if the changer is not expected to be in use for an extended period of time.

The stylus control has two normal positions (right and left) and one shipping position (lever pointing up). When playing 33 1/2 or 45 r.p.m. records the lever is turned so that "33-45" is visible on the TOP of the lever; likewise for 78 r.p.m. records "78" should be visible on the TOP.

The removable centerpost is for use with 45 r.p.m. records having the large centerhole. It must be placed over the center spindle with the "RCA" trademark monogram FACING to the FRONT. When not in use it is placed in a well at the front of the motorboard.

To load or remove records, the record stabilizer is lifted and turned off-side. After loading it is turned to the center where it rests on top of the stack of records.

MODEL 2-S-7,
Ch. RC1117D

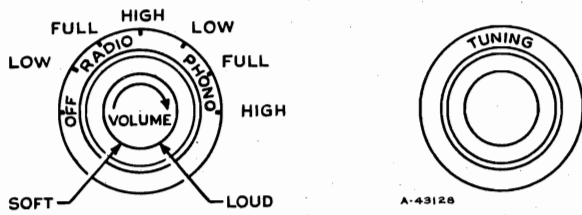

Radio Controls

Critical Lead Dress

1. Dress all leads away from R22.
2. Dress all filament leads down to chassis.
3. Dress output plate leads down to chassis.
4. Dress R12 close to chassis.

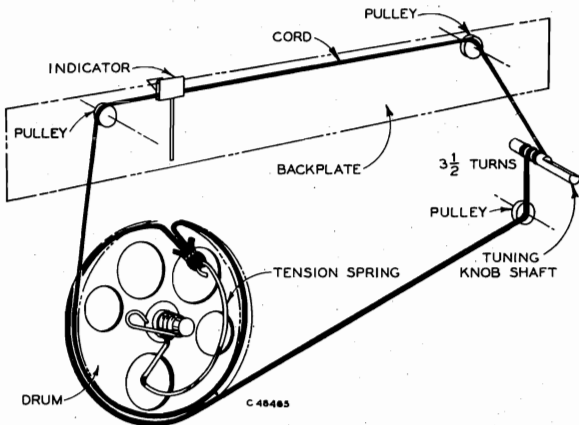

Dial Cord Layout

Alignment Procedure

Output Meter.—Connect meter across speaker voice coil. Turn volume control to maximum.

Test Oscillator.—Connect low side of test oscillator to common wiring in series with a .1 mf. capacitor. If the test oscillator is a.c. operated it may be necessary to use an isolation transformer for the receiver during alignment and the low side of the test oscillator connected directly to common wiring at the electrolytic capacitor. Keep the oscillator output low to prevent a-v-c action.

Steps	Connect the high side of test-oscillator to—	Tune test-osc. to—	Turn radio dial to—	Adjust the following for max. output
1	I.F. grid, in series with .1 mfd.	455 kc	Quiet point 1,600 kc end of dial	Pri. & Sec. 2nd I.F. transformer
2	Converter grid in series with .1 mfd.			Pri. & Sec. 1st I.F. transformer
NOTE.—ANTENNA LOOP MUST BE IN CABINET FOR THE FOLLOWING				
3	Short wire placed near loop for radiated signal	1,620 kc	Extreme R. H. end (gang open)	C22 (osc.)
4		1,400 kc	1,400 kc	C5 (ant.)
5		600 kc	600 kc Signal	L3 (Rock Gang)
6	Repeat steps 3, 4 & 5 if necessary			

Dial Pointer Adjustment.—Rotate tuning condenser fully counterclockwise (plates fully meshed). Adjust indicator pointer so that it is $3\frac{15}{16}$ " from the left hand edge of the dial back plate.

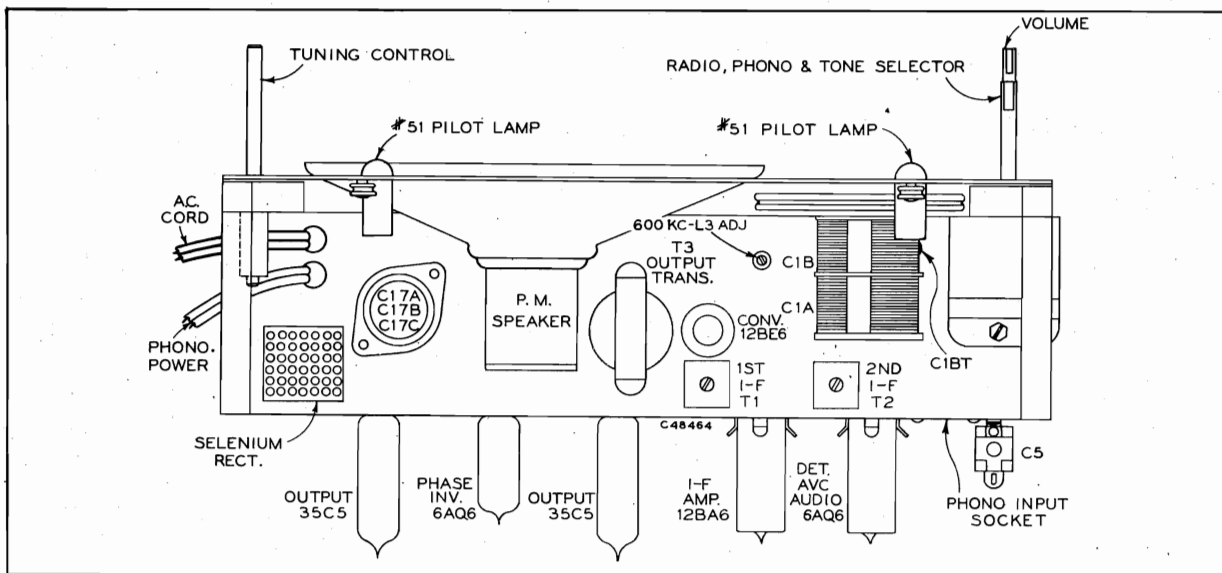

Tube and Trimmer Locations

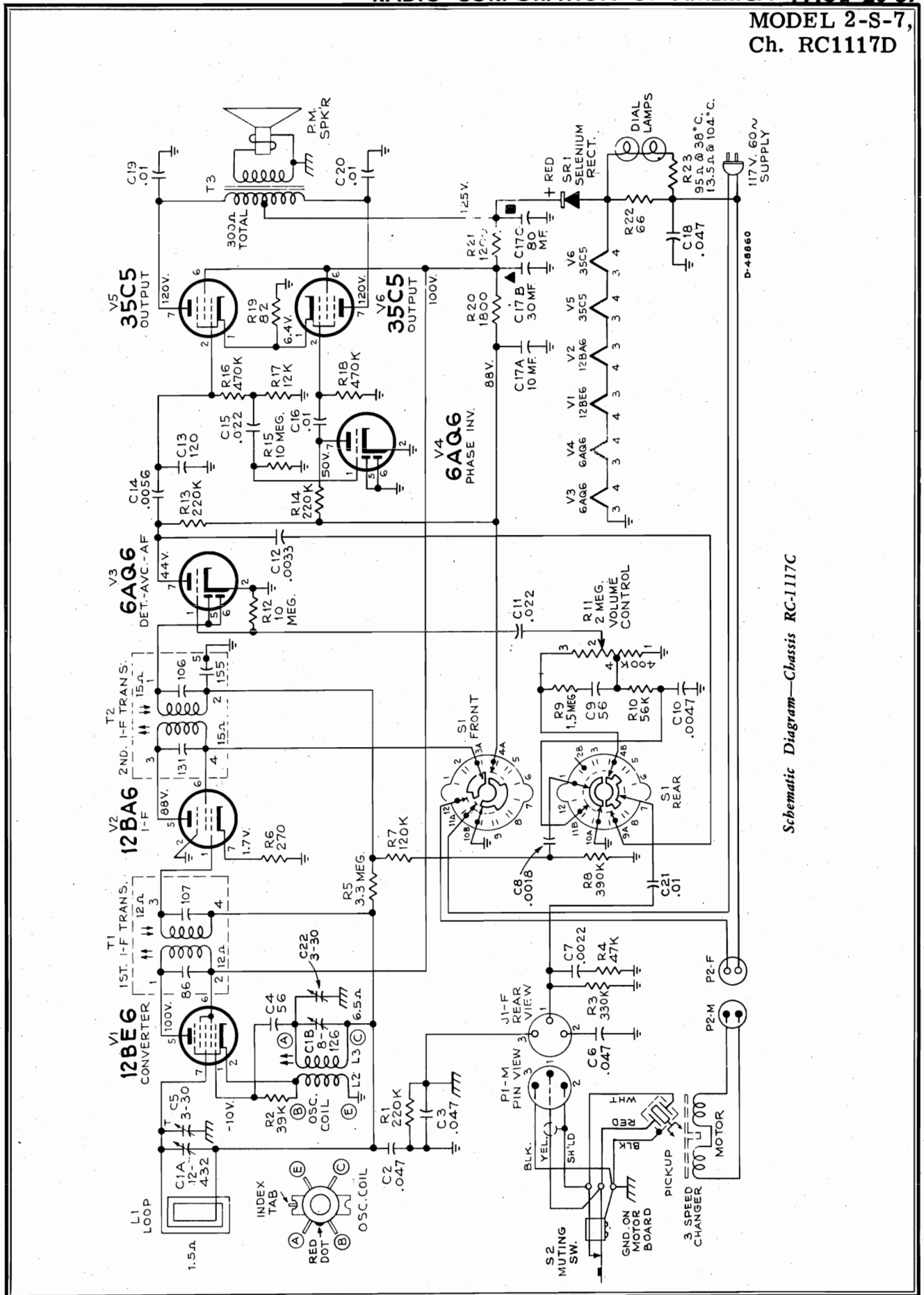

Schematic Diagram—Chassis RC-1117C

MODEL 2-S-7,
Ch. RC1117D

STOCK No.	PART DESCRIPTION	STOCK No.	PART DESCRIPTION
CHASSIS ASSEMBLIES RC1117D			
76876	Antenna—Antenna loop and back cover, L1	74697	Socket—Dial lamp socket
76867	Capacitor—Variable tuning capacitor, C1A, C1B	77115	Socket—Tube socket, 7 pin, miniature, moulded
76872	Capacitor—Adjustable trimmer, 2.5—30 mmf., C5, C22	51955	Socket—Tube socket, 7 pin, miniature, moulded saddle-mounted
77116	Capacitor—Fixed, ceramic, insulated, temp. coef.—3300, 56 mmf., ±20%, 500 volts DC, C4	76368	Spring—Drive cord spring
93603	Capacitor—Fixed, ceramic, insulated, high K type—56 mmf., ±10%, 500 volts, C9	76873	Switch—Function switch less volume control, S1
76347	120 mmf., ±20%, 500 volts, C13	77122	Transformer—Output transformer, T3
73013	Capacitor—Electrolytic: comprising 1 section of 80 mfd., 150 volts, 1 section of 30 mfd., 150 volts and 1 section of 10 mfd., 150 volts, C17A, C17B, C17C	74918	Transformer—First I.F. transformer complete with adjustable cores, T1
	Capacitor—Fixed, tubular, paper:	73037	Transformer—Second I.F. transformer complete with adjustable cores, T2
73851	.0018 mfd., 1600 volts, C8, C21	33726	Washer—"C" washer for tuning knob shaft
73595	.0022 mfd., 600 volts, C7	SPEAKER ASSEMBLIES 92586-4W RL10504 RMA-274	
73795	.0033 mfd., 400 volts, C12	75024	Cone—Cone and voice coil (3.2 ohms)
73920	.0047 mfd., 400 volts, C10	74664	Speaker—8" P.M. speaker complete with cone and voice coil (3.2 ohms)
73788	.0056 mfd., 400 volts, C14	MISCELLANEOUS	
73561	.01 mfd., 400 volts, C16, C19, C20	71892	Catch—Bullet catch and strike
73562	.022 mfd., 400 volts, C11, C15	70142	Clamp—Dial clamp (1 set)
73553	.047 mfd., 400 volts, C2, C3, C6	X3351	Cloth—Grille cloth for blonde mahogany instruments
75071	Capacitor—Fixed, tubular, moulded paper: .047 mfd., 400 volts, C18	X3350	Cloth—Grille cloth for mahogany or walnut instruments
73935	Clip—Mounting clip for I.F. transformer	30870	Connector—2 contact male connector for motor cable, P2
76866	Coil—Oscillator coil complete with adjustable core, L2, L3	74192	Connector—3 contact male connector for pickup cable, P1
36422	Connector—Phono input connector, J1	77898	Decal—Control function decal for blonde mahogany instruments
77114	Connector—Single contact male connector for loop lead	77897	Decal—Control function decal for mahogany or walnut instruments
75474	Connector—Single contact male connector for speaker cable	74273	Decal—"Victrola" decal
30868	Connector—2 contact female connector for motor cable, P2	77889	Dial—Glass dial scale
76874	Control—Volume control, R11	74205	Escutcheon—Dial scale escutcheon less dial
72953	Cord—250' Drive Cord Reel (approx. 54" overall req'd)	74838	Grommet—Power cord strain relief (1 set)
73690	Cord—Power cord and plug	77402	Handle—Pullout handle for record changer mechanism
74838	Grommet—Power cord strain relief (1 set)	74308	Hinge—Door hinge (1 set)
72283	Grommet—Rubber grommet for mounting variable capacitor	77892	Knob—Function switch knob—beige—for blonde mahogany instruments (outer)
11765	Lamp—Dial lamp—Mazda 51	77891	Knob—Function switch knob—maroon—for mahogany or walnut instruments (outer)
28452	Plate—Bakelite mounting plate for electrolytic	77382	Knob—Tuning control knob—beige—for blonde mahogany instruments (inner)
77926	Plate—Dial back plate complete less dial	77386	Knob—Tuning control knob—beige—for blonde mahogany instruments (outer)
77378	Pointer—Station selector pointer	75945	Knob—Tuning control knob—maroon—for mahogany or walnut instruments (inner)
76871	Rectifier—Selenium rectifier, SR1	77385	Knob—Tuning control knob—maroon—for mahogany or walnut instruments (outer)
73072	Resistor—Normal value 95 ohms, @ 38°C with negative temperature coefficient, R23	75464	Knob—Volume control knob—beige for blonde mahogany instruments (inner)
77379	Resistor—Wire wound, 66 ohms, 5 watts, R22	74963	Knob—Volume control knob—maroon—for mahogany or walnut instruments (inner)
	Resistors—Fixed, composition:	77894	Pan—Record changer mounting pan—beige—for blonde mahogany instruments
503082	82 ohms, ±10%, ½ watt, R19	77893	Pan—Record changer mounting pan—plum—for mahogany or walnut instruments
503127	270 ohms, ±10%, ½ watt, R6	76421	Pin—Slide mechanism stop pin
513212	1200 ohms, ±10%, 1 watt, R21	77896	Pull—Door pull
503218	1800 ohms, ±10%, ½ watt, R20	74113	Screw—#8-32 x 1" trimit head screw for door pull
503312	12,000 ohms, ±10%, ½ watt, R17	77895	Slide—Mounting pan slide mechanism
503339	39,000 ohms, ±10%, ½ watt, R2	76422	Spring—Retaining spring for slide mechanism stop pin
503347	47,000 ohms, ±10%, ½ watt, R4	30330	Spring—Retaining spring for knobs 74963 and 75464
503356	56,000 ohms, ±10%, ½ watt, R10	76837	Spring—Retaining spring for knobs 75945, 77382, 77385, 77386, 77891, 77892
503412	120,000 ohms, ±10%, ½ watt, R7	72936	Stop—Door stop
503422	220,000 ohms, ±10%, ½ watt, R1, R13, R14		
503433	330,000 ohms, ±10%, ½ watt, R3		
503439	390,000 ohms, ±10%, ½ watt, R8		
503447	470,000 ohms, ±10%, ½ watt, R16, R18		
503515	1.5 megohm, ±10%, ½ watt, R9		
503533	3.3 megohm, ±10%, ½ watt, R5		
503610	10 megohm, ±10%, ½ watt, R12, R15		
76869	Shaft—Tuning knob shaft		
76870	Shield—Tube shield		

APPLY TO YOUR RCA DISTRIBUTOR FOR PRICES OF REPLACEMENT PARTS

MODEL 3-BX-671,
Ch. RC-1125



THE STRATO-WORLD

Specifications

Tuning Ranges

Standard Broadcast "A" Band	540-1600 kc
"B" Band	2.0-4.0 mc
"C" Band	4.0-8.0 mc
31 Meter Spread Band	9.45- 9.85 mc
25 Meter Spread Band	11.55-12.05 mc
19 Meter Spread Band	14.90-15.55 mc
16 Meter Spread Band	17.50-18.20 mc

Intermediate Frequency 455 kc

Power Supply Rating

115 volts, d.c., or 25 to 60 cycles a.c. 20 watts

or

Battery Operation using RCA VS047 Battery
 Battery voltage "A" 9 volts, "B" 90 volts
 Battery current "A" 56 ma., "B" 14.5 ma.

or

230 volts d.c., or 25 to 60 cycles a.c. using
 RK-186 Converter Accessory

Tube Complement

(1) RCA 1U4	R.F. Amplifier
(2) RCA 1L6	Converter
(3) RCA 1U4	I.F. Amplifier
(4) RCA 1U5	Det.-AVC-1st A.F.
(5) RCA 3V4	Output
RCA Stock No. 78101	Selenium Rectifier

Loudspeaker

Size and Type 5¼ in. P.M.
 Voice coil impedance 3.2 ohms at 400 cycles

Power Output

Undistorted 0.22 watt
 Maximum 0.42 watt

Tuning Drive Ratio 11½:1

Weight (Approximate)

Less Battery 16 lbs.
 With Battery (RCA VS047) 23 lbs.

Dimensions (Overall)

Height 11½ in. Width 17½ in. Depth 8 in.

Operating Instructions

Rotate POWER-VOLUME knob to right until a click is heard, and advance for about half a turn. Rotate BAND SELECTOR knob until desired band marking on knob is directly beneath the red triangle. A white indicator will appear at right of desired band on dial. To obtain reception on any one of the six Short Wave bands, the telescopic rod antenna must be used. See instructions under "General Information." Rotate TUNING knob until dial pointer indicates desired frequency marking on the desired band. Rotate TREBLE and BASS tone control knobs as desired. Treble tone increases as TREBLE knob is rotated clockwise. BASS tone increases as BASS knob is rotated counter-clockwise.

Headphones — A "PHONES" receptacle, for connection of headphones, is located on the rear of the chassis. Should individual listening be desired, any standard headphone set with standard plug may be inserted, automatically disconnecting the speaker.

Ground Terminal — A terminal for ground connection is located on the rear of the chassis. To improve reception in

weak-signal areas, connect a ground wire from this terminal ("GND") to a cold-water pipe, or other suitable ground. "GND" connection is not necessary when operating on power line.

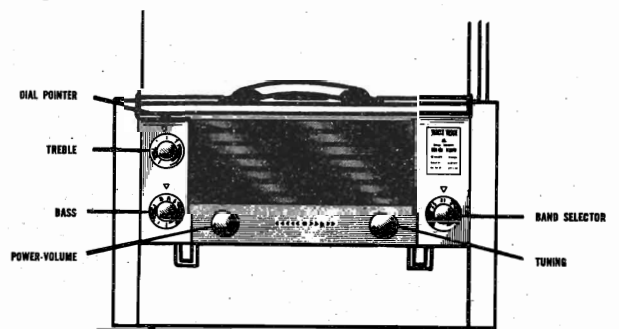

Operating Controls

MODEL 3-BX-671,
Ch. RC-1125

Circuit Description

The seven band 3BX671 portable instrument is a sensitive three-way receiver designed to operate from an AC or DC power source, or from a self-contained battery pack. With the addition of an RK-186 converter, the receiver may be operated on 210-250 volts AC or DC. A chassis jack is provided for this converter.

The receiver incorporates a 7 band tuner covering the broadcast band "A band"; two short wave bands, 2-4 mc. and 4-8 mc. "B and C bands"; also four short wave spread bands, 31, 25, 19, and 16 meters. The superheterodyne circuit is used with a tuned R.F. stage preceding the pentagrid converter on all bands; one I.F. stage; a combined AVC, detector, and A.F. stage; and a power amplifier stage. A selenium rectifier is used.

R.F. tuning is done by means of a ganged six section variable capacitor. Three large sections are used for the A, B, and C bands with series tracking capacitors. Also, three small 3 plate sections for electrical band spread are used on the four spread bands. The tuner, including the function switch, coil and trimmer assembly, R.F. and converter tubes and gang capacitor, is a completely detachable unit featuring high efficiency with small physical size. The special design permits access to the coil and trimmer adjustments from the rear.

A headphone jack is located on the chassis rear apron for individual listening. This jack automatically disconnects the speaker when the headphone plug is inserted. The slide rule type dial includes 7 separate scales on a slotted escutcheon to provide speaker openings. Continuously variable treble and bass tone controls are provided. This receiver features 3 separate antenna systems. A large flat loop built within the hinged lid includes a primary for external antenna connection, when desired. A Ferrite rod antenna with a long cable and provided with suction cups to permit mounting on a window or wall for improved pickup in shielded areas is supplied. The preceding antennas are used only on the standard broadcast band. A telescoping vertical rod antenna is provided for use on all short wave bands.

All tubes and the battery may be serviced by opening the hinged back cover. A terminal is provided on the back apron of the cover for an external ground connection, if desired. A line voltage compensator switch is mounted on the chassis rear apron under a caution label of instructions. The switch is to be used only in areas of sub-standard line voltage.

Alignment Fixture

To obtain maximum sensitivity when chassis is reinserted in case after alignment, the alignment fixture shown below should be secured to the tuner side of the chassis during alignment to simulate the effect of the case. The sheet metal clips and hardware on the dust cover base may temporarily be used to hold the fixture to the chassis.

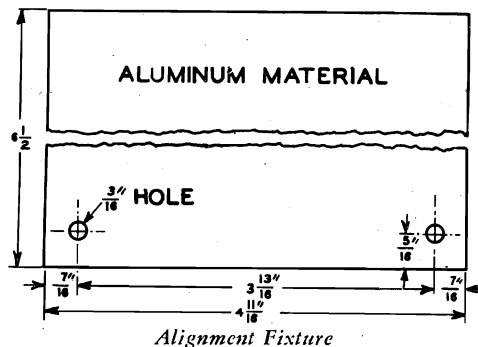

CHASSIS REMOVAL

1. Turn tuning knob until gang is fully closed.
2. Open cabinet back, pull out battery, and disconnect battery plug.
3. Remove pull-off type volume, tuning, band selector, and tone control knobs.
4. Remove the four machine screws holding the chassis to the case.
5. Pull chassis out and simultaneously slightly downward, to enable dial pointer mechanism to clear top back edge of case.

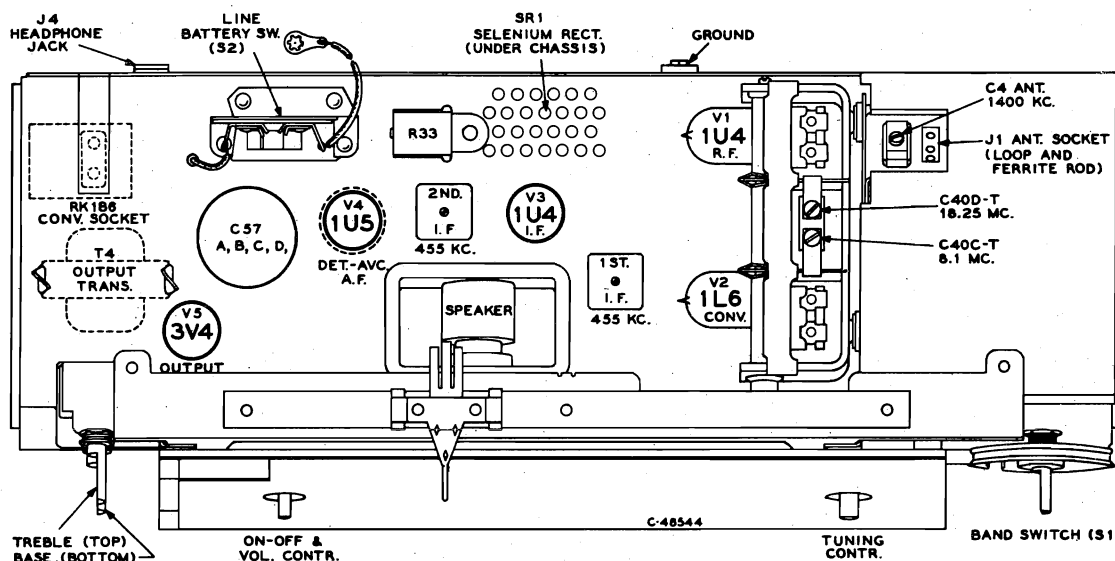
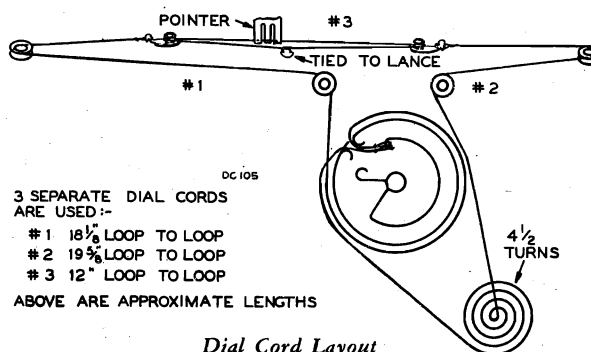

Chassis Top View

Alignment Procedure

Output Meter Alignment—If this method is used, connect the meter across the voice coil and turn the receiver volume control to maximum.

Test Oscillator—For all alignment operations, connect the low side of the test oscillator to the receiver chassis and keep the oscillator output as low as possible to avoid AVC action.

Close gang and set dial pointer to mark on dial plate. Turn volume and treble tone controls to maximum clockwise position. Turn bass tone control to maximum counterclockwise position.					
STEP	CONNECT HIGH SIDE OF SIG. GEN. TO—	SIGNAL GEN. OUTPUT	DIAL POINTER SETTING	ADJUST FOR MAXIMUM OUTPUT	
1.	Pin #6 of 1U4 I.F. Amp. thru 0.01 mfd.	455 kc	"A" Band Quiet point near 1600 kc	T3 top and bottom cores	
2.	Pin #6 of 1L6 Conv. thru 0.01 mfd.			T2 top and bottom cores	
3.	Install bottom cover. Secure aluminum alignment fixture in place. Connect 24 mmfd. in series with 22 ohms between sig. generator lead and C39.				
4.	C39, term. 7 on SID thru dummy load indicated	18.25 mc	16M Band Right hand stop	*C40D-T top of gang	
5.		17.5 mc	16M Band Left hand stop	T11 Osc.	
6.		17.8 mc	16M Band 17.8 mc Signal	Rock gang, —Peak L11 R.F. + L5 Ant.	
7.		14.9 mc	19M Band Left hand stop	T10 Osc.	
8.		15.2 mc	19M Band 15.2 mc Signal	Rock gang, —Peak L12 R.F. + L6 Ant.	
9.		11.55 mc	25M Band Left hand stop	T9 Osc.	
10.		11.8 mc	25M Band 11.8 mc Signal	Rock gang, —Peak L13 R.F. + L7 Ant.	
11.		9.45 mc	31M Band Left hand stop	T8 Osc.	
12.		9.6 mc	31M Band 9.6 mc Signal	Rock gang, —Peak L14 R.F. + L8 Ant.	
13.		8.1 mc	"C" Band Right hand stop	*C40C-T top of gang. C16 R.F. C7 Ant.	
14.		3.9 mc	"C" Band Left hand stop	T7 Osc. L9 R.F. L4 Ant.	
15.		Repeat steps 13 and 14 until maximum gain is obtained.			
16.		4.05 mc	"B" Band Right hand stop	C32 Osc. C18 R.F. C5 Ant.	
17.		1.97 mc	"B" Band Left hand stop	T6 Osc. L10 R.F. L3 Ant.	
18.		Repeat steps 16 and 17 until maximum gain is obtained. Remove alignment fixture and install chassis in cabinet. Plug in loop cable.			
19.		Short length of wire near receiver	1620 kc	"A" Band Right hand stop	C31 Osc.
20.			1400 kc	"A" Band 1400 kc Signal	C20 R.F. C4 Ant.
21.			600 kc	"A" Band 600 kc Signal	Rock gang, —Peak T5 Osc. trans., + T1 R.F.
22.	Repeat steps 19, 20 and 21 until maximum gain is obtained. Exchange loop antenna plug with external Ferrite Rod antenna plug. Extend cable to maximum.				
23.	1400 kc		"A" Band 1400 kc Signal	C43 Ferrite Rod Ant.	

*The tuning range and dial calibration of the succeeding bands depend upon the accuracy of this adjustment. Avoid aligning on image. The local oscillator is 455 kc higher in frequency than the RF on all bands.

Battery operation of the receiver is preferable during alignment; on AC operation, an isolation transformer (117v./117v.) may be necessary for the receiver if the test oscillator is also AC operated.

Critical Lead Dress

1. Dress all filament leads next to chassis.
2. Use short pigtail leads on all by-pass and coupling capacitors associated with R.F. circuits.
3. Dress gang condenser leads direct and short as possible to switch without strain.
4. Connect neutralizing capacitor C50, 0.51 MMFD across converter socket with short leads and away from other components.
5. Dress power line compensator resistor to clear surrounding components and bottom cover.
6. Dress coil pigtail leads away from each other and from coils.
7. Dress blue converter plate lead down to base.
8. Dress volume control leads down to base.

CAUTION —

Do not remove any tubes from the chassis with the set operating and the plug connected to the power line. Damage to tubes may result.

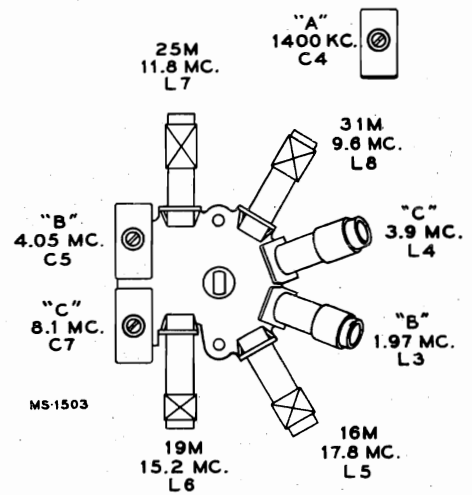

Tuner Adjustment Locations—Antenna

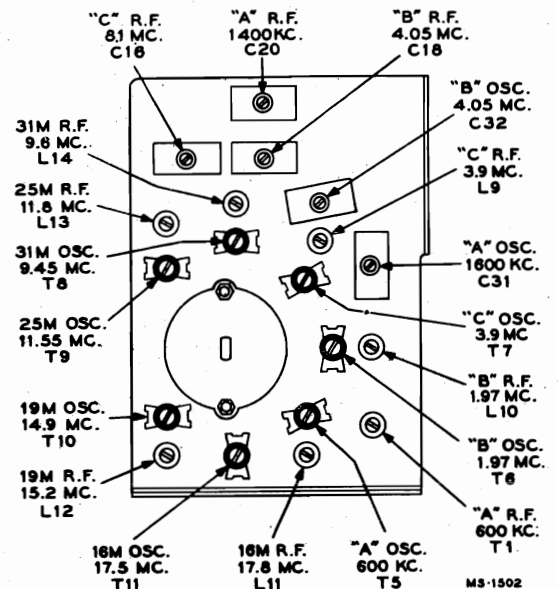

Tuner Adjustment Locations—Oscillator and R.F.

CH. RC-1125

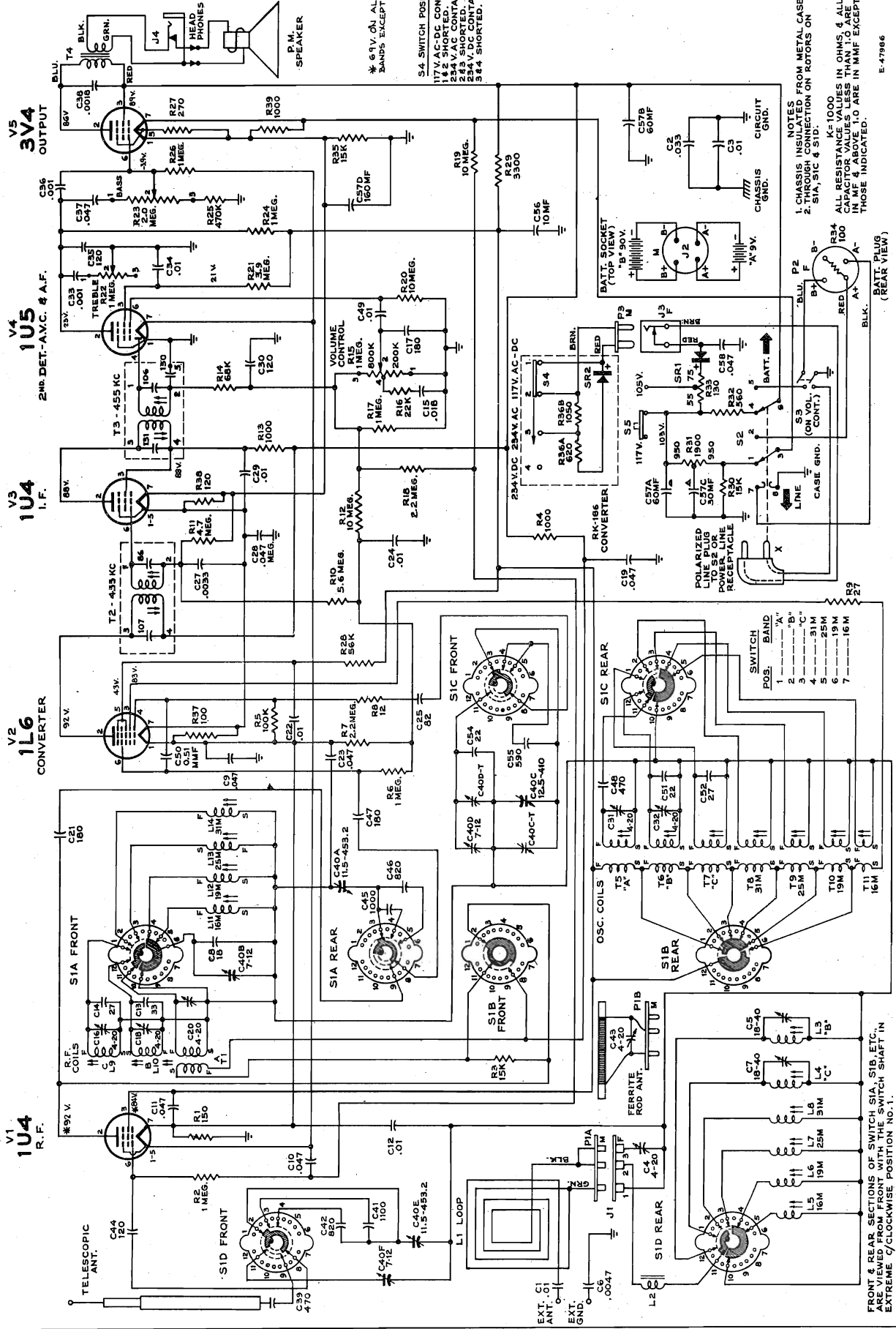

* 6.9 V. ON ALL BANDS EXCEPT "A".
 S4 SWITCH POSITIONS
 1 17V AC-DC CONTACTS
 2 234 V AC CONTACTS
 3 234 V DC CONTACTS
 4 234 V DC CONTACTS
 5 234 V DC CONTACTS
 6 234 V DC CONTACTS
 7 234 V DC CONTACTS
 8 234 V DC CONTACTS
 9 234 V DC CONTACTS
 10 234 V DC CONTACTS

NOTES FROM METAL CASE.
 1. CHASSIS INSULATION FROM METAL CASE.
 2. THROUGH CONNECTION ON ROTORS ON S1A, S1C & S1D.
 K=1000
 ALL RESISTANCE VALUES IN OHMS, & ALL IN MF & ABOVE 1.0 ARE IN MMF EXCEPT THOSE INDICATED.

Schematic Diagram—Chassis No. RC-1125

E-47986

General Information

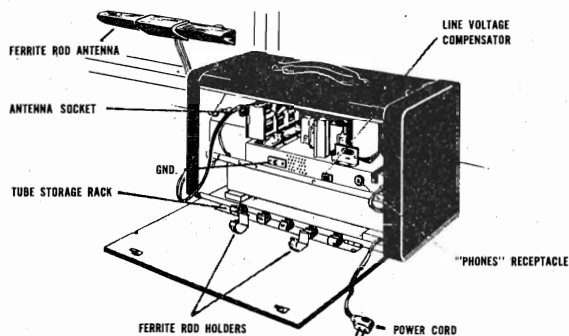

Rear View

AC-DC OPERATION

For 105 to 125 volts, 25-60 cycles AC or 105 to 125 volts DC operation—Be sure that the power line used has the correct voltage and frequency before turning on the receiver. Open case back, remove power cord plug from chassis socket, and insert in outlet. Feed power cord through the notch on the lower right side of the case back.

RK-186 VOLTAGE CONVERTER

For 210 to 250 volts, 25-60 cycles AC or 210 to 250 volts DC operation—Pull open case back and remove L-shaped metal bracket held by single self-tapping screw located between headphone jack and power cord. Insert RK-186 Converter in socket provided with metal tab facing to the rear. Secure RK-186 Converter to chassis by replacing screw through tab hole.

BATTERY OPERATION

Installation of Battery Pack—Insert battery cable plug into battery socket, installing battery pack with plug side facing toward the front.

For Battery Operation—Insert polarized power cord plug all the way into the chassis socket. Store excess power cord neatly to the right side of the battery pack. Close case back securely.

CARE OF INSTRUMENT CASE

To best preserve the appearance and serviceability of the instrument case, keep it clean. For this purpose, any mild soap will do, if applied as a lather and the dirt removed with a dry, clean cloth. Abrasives, commercial cleaning fluids, nail polish remover and the like should not be used.

Should leather become dry from cleaning or aging, the natural oils should be replaced. For restoration purposes, a number of applications of 10 to 20 per cent of sulfonated castor, or neatsfoot, or cod oil may be made as required.

LINE VOLTAGE COMPENSATOR

Weak reception may result from sub-normal power line voltage. If determined as the cause (check voltage rating with power company), the Line Voltage Compensator is provided to improve reception by switching to "LOW LINE VOLTAGE" position. To use, break the caution label seal, and move the switch slot to the right. Use of this feature is not recommended unless the line voltage is 105 volts or less.

USE OF ANTENNAS

Built-In Loop—For Standard Broadcast

Contained in the hinged lid of the case, this antenna is in use as long as it remains plugged into the antenna socket. It is possible to improve reception by rotating the receiver.

Ferrite Rod—For Standard Broadcast—Low Signal/Noise Areas

To improve reception within steel buildings, automobiles, etc., the ferrite rod antenna may be used. Remove loop antenna plug from its socket. Remove ferrite rod antenna from spring clips inside back cover, unwind wire extension, and insert cable plug into antenna socket. The ferrite rod antenna may be secured on a window in a horizontal position, by pressing the suction cups firmly against the glass. Reception may be improved by changing the position of the antenna.

External—For Standard Broadcast—Weak Signal Areas

A terminal for outside antenna connection is located on the hinged lid of the case. Connect a wire to this terminal and suspend approximately 60 to 100 feet in space, at least 50 feet in a horizontal position.

Telescopic Rod—For Short Wave

Concealed within the case on the right, this antenna is used for reception on any one of the six Short Wave bands. To use, press release button on lower right side of case, and antenna top will appear above its opening. Grasp antenna top, and pull up antenna sections until a distinct snap or click results. For best reception, all sections should be fully extended.

NOTE: Short Wave reception is impossible unless bottom (Satin Finish) section of antenna is snapped into its elevated position.

Stock No.	DESCRIPTION	Stock No.	DESCRIPTION
	CHASSIS ASSEMBLIES RC 1125		
78135	Board—Baffle board and grille screen less speaker	78140	33 mmf., ±10%, 500 volts (C13)
78104	Board—"Gnd." board	78142	120 mmf., ±10%, 500 volts (C30, C35, C44)
78091	Bushing—Fibre bushing for chassis mounting shelf	78137	Capacitor—Fixed, headed-lead:— 0.51 mmf., ±10%, 500 volts (C50)
78108	Capacitor—Variable tuning capacitor complete with drive drum (C40A, C40B, C40C, C40D, C40E, C40F, C40C-T, C40D-T)	39644	Capacitor—Fixed, mica:— 470 mmf., ±5%, 500 volts (C48)
78146	Capacitor—Capacitor (82 mmf.) and resistor (12 ohms) assembly (C25, R8)	76932	470 mmf., ±20%, 300 volts (C39)
	Capacitor—Adjustable, mica:— 4-20 mmf. (C4, C16, C18, C20)	74929	590 mmf., ±2%, 500 volts (C55)
78130	4-20 mmf. (C31, C32)	78143	820 mmf., ±5%, 300 volts (C42, C46)
78131	20-50 mmf. (C5, C7)	39652	1000 mmf., ±5%, 300 volts (C45)
78132	Capacitor—Fixed, ceramic, High "K" disc:— 10,000 mmf., ±100%, -0%; 500 volts (C, C12, C22, C24, C29, C34)	78144	1100 mmf., ±2%, 500 volts (C41)
73960	Capacitor—Fixed, ceramic, non-insulated: 22 mmf., ±10%, 500 volts Temp. coef. = -750 (C51, C54)		Capacitor—Electrolytic comprising:— 1 section of 60 mfd., 350 volts, 1 section of 60 mfd., 150 volts, 1 section of 30 mfd., 150 volts, 1 section of 160 mfd., 25 volts (C57A, C57B, C57C, C57D)
33101	27 mmf., ±10%, 500 volts Temp. coef. = -750 (C52)	78145	Capacitor—Fixed, electrolytic:— 10 mfd., 150 volts (C56)
72570	Capacitor—Fixed, ceramic, insulated, High "K" type: 18 mmf., ±10%, 500 volts (C8)	75643	Capacitor—Fixed paper moulded:— .001 mfd., 1000 volts (C33, C36)
78138	180 mmf., ±10%, 500 volts (C17, C21, C47)	73851	.0018 mfd., 1600 volts (C38)
78139	Capacitor—Fixed, ceramic, non-insulated, High "K" type:— 27 mmf., ±10%, 500 volts (C14)	73795	.0033 mfd., 600 volts (C27)
		73920	.0047 mfd., 600 volts (C6)
		73561	.01 mfd., 400 volts (C49)
		58476	.018 mfd., 400 volts (C15)
		73552	.033 mfd., 400 volts (C2)
		73558	.047 mfd., 200 volts (C9, C10, C23, C28, C37)
		73553	.047 mfd., 400 volts (C11, C19)
		73592	.047 mfd., 600 volts (C58)
		73935	Clip—Mounting clip for I.F. transformer

MODEL 3-BX-671,
Ch. RC-1125

Stock No.	DESCRIPTION	Stock No.	DESCRIPTION
78123	Coil—Antenna coil—"B" band (L3)	74918	Transformer—1st I.F. transformer complete with adjustable core (T2)
78124	Coil—Antenna coil—"C" band (L4)	73037	Transformer—2nd I.F. transformer complete with adjustable core (T3)
78128	Coil—Antenna coil—16 meter band (L5)	78100	Transformer—Output transformer (T4)
78127	Coil—Antenna coil—19 meter band (L6)	33726	Washer—"C" washer for tuning knob shaft
78126	Coil—Antenna coil—25 meter band (L7)		SPEAKER ASSEMBLIES 971933-2
78125	Coil—Antenna coil—31 meter band (L8)		Gasket—Rubber gasket (3/4") for speaker
78129	Coil—Loading coil (L2)	74378	Speaker—3/4" P.M. speaker complete with cone and voice coil (3.2 ohms)
78109	Coil—Oscillator coil—"A" band (T5)	78147	
78110	Coil—Oscillator coil—"B" band (T6)		MISCELLANEOUS
78111	Coil—Oscillator coil—"C" band (T7)	78196	Antenna—Ferrite rod antenna complete with winding
78115	Coil—Oscillator coil—16 meter band (T11)	78187	Antenna—Lid and antenna loop assembly complete (L1, C1)
78114	Coil—Oscillator coil—19 meter band (T10)	78157	Antenna—Telescopic antenna
78113	Coil—Oscillator coil—25 meter band (T9)	78184	Back—Case back complete
78112	Coil—Oscillator coil—31 meter band (T8)	78158	Bearing—Bearing (phenolic tube) for telescopic antenna
78116	Coil—RF coil—"A" band (T1)	78189	Bearing—Case lid bearing
78117	Coil—RF coil—"B" band (L10)	78174	Bracket—"U" shape bracket (clevis) for carrying handle links
78118	Coil—RF coil—"C" band (L9)	78166	Button—Telescopic antenna push button
78122	Coil—RF coil—16 meter band (L11)	78165	Cap—Telescopic antenna screw-on cap
78121	Coil—RF coil—19 meter band (L12)	75967	Capacitor—Adjustable, mica, 4-20 mmf. (C43)
78120	Coil—RF coil—25 meter band (L13)	78190	Case—Case only for ferrite rod antenna
78119	Coil—RF coil—31 meter band (L14)	78153	Case—Case less sides, handle, links, feet front and back cover
7903	Connector—Earphone jack (J4)	78170	Catch—Case catch
71040	Connector—2 contact female connector for 220 volt operation (J3)	78186	Catch—Case back catch—part of case back
38904	Connector—2 contact female connector for AC line cord	78185	Clip—Mounting clip for ferrite rod antenna
78133	Connector—3 contact female connector for antenna leads (J1)	78411	Clip—Clip for case catch—bottom
30567	Connector—4 contact female connector for battery cable (P2)	78177	Connector—3 contact male connector for antenna loop and for ferrite rod antenna (PIA, PIB)
78094	Control—Bass tone control (R23)	78162	Contact—Bottom contact for telescopic antenna
78093	Control—Treble tone control (R22)	78163	Contact—Formed spring clip and contact for telescopic antenna—upper
78092	Control—Volume control and power switch (R15, S3)	78164	Contact—Lower contact and push button catch
70022	Cord—Power cord and plug	78195	Cover—Bottom cover for ferrite rod antenna
*72953	*Cord—Station selector pointer drive cord (approx. 15" overall)	78191	Cup—Suction cup for ferrite rod antenna case
72953	Cord—Station selector pointer drive cord (approx. 22" overall)	78159	Cushion—Adhesive cushion for bottom of antenna bearing
72953	Cord—Station selector pointer or band indicator pointer drive cord (approx. 24" overall)	75470	Cushion—Rubber cushion for battery support
78242	Cushion—Rubber cushion for baffle board (4 1/8" long)	78193	Cushion—Rubber spacer cushion (1/8" x 13/16" dia.) for ferrite rod antenna
78105	Cushion—Rubber cushion for baffle board (10 1/2" long)	78194	Cushion—Rubber spacer cushion (1/2" x .328" I.D. x 13/16" O.D.) for ferrite rod antenna
78097	Eyelet—Station selector pointer drive cords connecting eyelet	78181	Dial—Dial scale less escutcheon
74838	Grommet—Power cord strain relief (1 set)	77012	Emblem—"RCA Victor" emblem
16058	Grommet—Rubber grommet for mounting gang capacitor	78182	Escutcheon—Dial scale escutcheon less dial
71851	Grommet—Rubber grommet for speaker mounting	78169	Foot—Rubber foot
78086	Guide—Station selector pointer guide rail and pulley assembly	78173	Handle—Carrying handle
78099	Nut—Speed nut for tuner shield	78156	Hinge—Hinge for back cover (2 req'd)
78098	Nut—Speed nut for baffle board mounting (4 req'd) or for tuner shield	78167	Insulator—Nylon insulator for case lid
78103	Nut—Speed nut (twin type) to fasten pointer bracket	78171	Latch—Latch for back cover
18469	Plate—Bakelite mounting plate for electrolytic	78187	Lid—Case lid and antenna loop assembly (L1, C1)
78090	Pointer—Band indicator pointer	78175	Link—Carrying handle link
78087	Pointer—Station selector pointer	78149	Knob—Bass tone control knob
78107	Pulley—Band indicator drive pulley and knob assembly	78151	Knob—Range switch knob
72602	Pulley—Drive cord pulley—part of pointer guide rail or for station selector pointer drive cord pulley	78150	Knob—Treble tone control knob
78101	Rectifier—Selenium rectifier (SR1)	78148	Knob—Tuning control or volume control and power switch knob
78136	Resistor—Wire wound:— comprising 1 section of 75 ohms, 5 watts and 1 section of 55 ohms, 5 watts (R33)	78414	Map—World map and time chart
78102	Resistor—Fixed, composition:— dual 950 ohms, 3/2 watts (R31)	73203	Nut—Speed nut to fasten "RCA Victor" emblem
503027	27 ohms, ±10%, 1/2 watt (R9)	78192	Plate—Bakelite plate for ferrite rod antenna trimmer capacitor
503110	100 ohms, ±10%, 1/2 watt (R34, R37)	78172	Plate—Mounting plate for carrying handle
503112	120 ohms, ±10%, 1/2 watt (R38)	78180	Rack—Spare tube rack
503115	150 ohms, ±10%, 1/2 watt (R1)	78183	Screw—#4-40 x 1/4" cross recessed flat head tapping screw to fasten dial to escutcheon
503127	270 ohms, ±10%, 1/2 watt (R27)	77974	Side—Case side—L.H.—complete with leather belting
513156	560 ohms, ±10%, 1 watt (R32)	77975	Side—Case side—R.H.—complete with leather belting
503210	1000 ohms, ±10%, 1/2 watt (R4, R13, R39)	78188	Spring—Case lid spring
503233	3300 ohms, ±10%, 1/2 watt (R29)	78160	Spring—Push-up spring for telescopic antenna
503315	15,000 ohms, ±10%, 1/2 watt (R3, R30, R35)	74734	Spring—Spring clip for control knobs
503322	22,000 ohms, ±10%, 1/2 watt (R16)	78154	Strap—Leather strap for L.H. case side
503356	56,000 ohms, ±10%, 1/2 watt (R28)	78155	Strap—Leather strap for R.H. case side
503368	68,000 ohms, ±10%, 1/2 watt (R14)	78413	Strap—Strap for holding ferrite rod antenna lead
503410	100,000 ohms, ±10%, 1/2 watt (R5)	78168	Support—Battery support (wood)
503447	470,000 ohms, ±10%, 1/2 watt (R25)	78161	Support—Telescopic antenna bearing support—at top of antenna
503510	1 megohm, ±10%, 1/2 watt (R2, R6, R17, R24, R26)	77467	Washer—Felt washer for knob
503522	2.2 megohm, ±10%, 1/2 watt (R7, R18)	78152	Washer—Insulating washer for control knobs
503539	3.9 megohm, ±10%, 1/2 watt (R21)	78178	Washer—Insulating washer for case lid pivot
503547	4.7 megohm, ±10%, 1/2 watt (R11)	78179	Washer—Vellutex washer for dial and bezel mounting
503556	5.6 megohm, ±10%, 1/2 watt (R10)	78412	Washer—Vellutex washer for case catch clip
503610	10 megohm, ±10%, 1/2 watt (R12, R19, R20)		RK 186 CONVERTER
78088	Shaft—Tuning knob shaft	78303	Connector—2 contact male connector (P3)
78089	Shield—Bakelite shield for tuner unit	77958	Rectifier—Selenium rectifier (SR2)
73584	Shield—Tube shield	78302	Resistor—Wire wound, comprising:— 1 section of 620 ohms, 10 watts, and 1 section of 1050 ohms, 5 watts (R36)
78134	Socket—Tube socket, miniature, 7 pin, floating	78304	Switch—Voltage change switch (S4)
73117	Socket—Tube socket, miniature, 9 pin, wafar		
74305	Spring—Band indicator pointer drive cord spring		
76332	Spring—Station selector pointer drive cord spring		
71039	Switch—Battery switch (S2)		
78096	Switch—Weak signal area switch (S5)		
78106	Switch—Range switch (S1)		

*Note:—72953 is a spool containing 250 ft. of cord.

MODEL 2US7,
Ch. RC1117A, C



SPECIFICATIONS

Tuning Range 540 - 1600 kc.

Intermediate Frequency 455 kc.

Tube Complement

- 1. RCA 12BE6 Converter
 - 2. RCA 12BA6 I.F. Amplifier
 - 3. RCA 6AQ6 Detector—A.F. Amplifier
 - 4. RCA 6AQ6 Phase Inverter
 - 5. RCA 35C5 } Push Pull Output
 - 6. RCA 35C5 }
- A selenium rectifier Stock #76871 is used.

Power Supply Rating

- 1. 115 volts A.C., 60 cycles
(uses 930409-5 or -10 Changer) 45 watts
- 2. 115 volts A.C., 50 cycles
(uses 930409-11 Changer) 45 watts

Dial Lamps (2) Mazda type 51, 6-8 volts, 0.2 amp.

Loudspeaker

Size and type 5" x 7" P.M.
Voice coil impedance 3.2 ohms at 400 cycles

Power Output

Undistorted 2.0 watts
Maximum 2.4 watts

Cabinet Dimensions

Height 10" Width 16 3/4" Depth 20 3/4"

Tuning Drive Ratio 14 1/4:1 (7 7/8 turns of knob)

Record Changer (930409-5, -10 or -11)

Turntable speed 33 1/3, 45 or 78 r.p.m.
Record capacity up to fourteen 7 inch RCA type
or twelve 10 inch
or ten 12 inch
or ten 10 in. and 12 in. intermixed.
Pickup (Stock No. 75475) Crystal with replaceable styli.

Weight 26 lbs. net

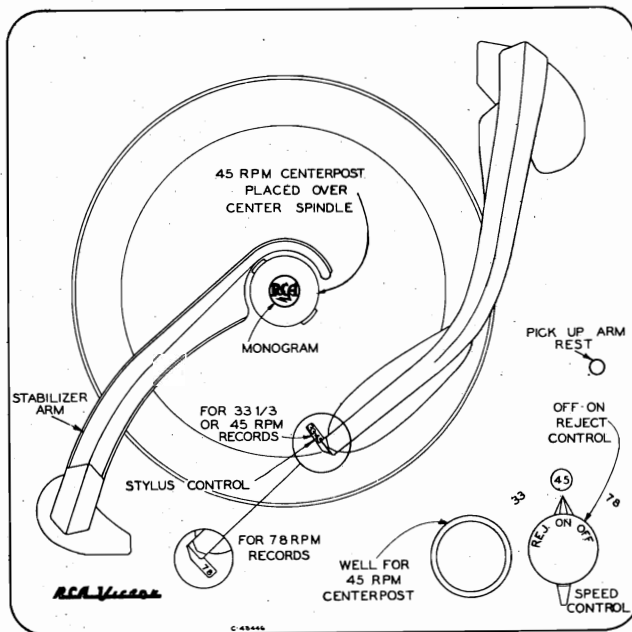

Record Changer Controls

RECORD CHANGER CONTROLS

The record changer has a dual control on the motor-board and a stylus selector control on the pickup arm. The inner control (circular knob) is the OFF-ON-REJECT control. Turning this knob to the center position energizes the motor and starts the turntable, when turned to the right (clockwise) it starts the mechanism into complete automatic operation. The mechanism will shut off automatically after the last record has been played but can be shut off manually by turning this knob to the left (counter-clockwise).

The outer control (double ended lever) is the speed control. It has three normal positions, "33", "45", "78" to select the turntable speed desired and a neutral position (midway between "45" and "78"). The control should be turned to this neutral position if the changer is not expected to be in use for an extended period of time.

The stylus control has two normal positions (right and left) and one shipping position (lever pointing up). When playing 33 1/3 or 45 r.p.m. records the lever is turned so that "33-45" is visible on the TOP of the lever; likewise for 78 r.p.m. records "78" should be visible on the TOP.

The removable centerpost is for use with 45 r.p.m. records having the large centerhole. It must be placed over the center spindle with the "RCA" trademark monogram FACING to the FRONT. When not in use it is placed in a well at the front of the motorboard.

To load or remove records, the record stabilizer is lifted and turned off-side. After loading it is turned to the center where it rests on top of the stack of records.

MODEL 2US7,
Ch. RC1117A, C

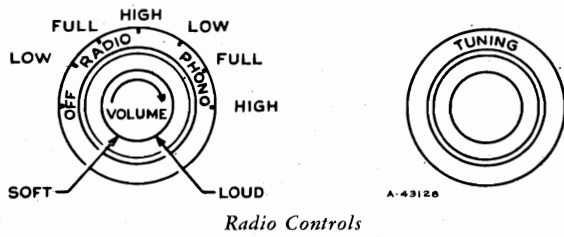

Radio Controls

Service Hints

All tubes, except the 12BE6, are accessible for testing by lifting up one side of the cabinet and removing the tubes from the rear chassis apron. To service the 12BE6 tube and the pilot lights, remove the four wood screws holding the sloping panel at the front of the record changer compartment. This panel also holds the loop antenna.

To remove the radio chassis for service, first remove the push-on type knobs. Secure the record changer pickup arm to the center post and rest the cabinet on its side. Remove loop antenna connections, and pickup arm audio plug. Hook-on connectors are used to connect a.c. power from the radio chassis to the phono motor. These connectors are covered by taped-over black insulating sleeves located in one corner of the cabinet. Push back sleeves and unhook. Remove the four flat-head wood screws holding the chassis mounting board to the bottom of the cabinet. Slide chassis out of cabinet, then remove the three 1/4 inch hex head self-tapping screws holding the chassis to the panel.

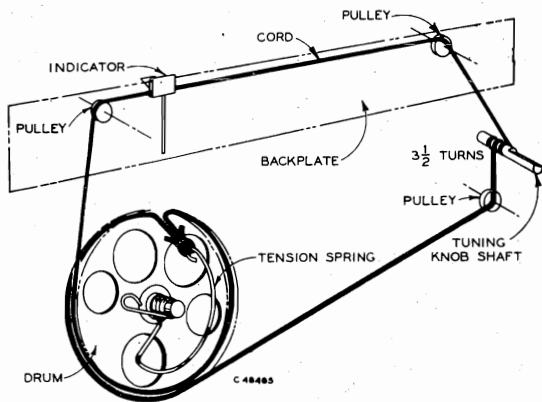

Dial Cord Layout

Alignment Procedure

Output Meter.—Connect meter across speaker voice coil. Turn volume control to maximum.

Test Oscillator.—Connect low side of test oscillator to common wiring in series with a .1 mf. capacitor. If the test oscillator is a.c. operated it may be necessary to use an isolation transformer for the receiver during alignment and the low side of the test oscillator connected directly to common wiring at the electrolytic capacitor. Keep the oscillator output low to prevent a-v-c action.

Steps	Connect the high side of test-oscillator to—	Tune test-osc. to—	Turn radio dial to—	Adjust the following for max. output
1	I.F. grid, in series with .1 mfd.	455 kc	Quiet point 1,600 kc end of dial	Pri. & Sec. 2nd I.F. transformer
2	Converter grid in series with .1 mfd.			Pri. & Sec. 1st I.F. transformer
NOTE.—ANTENNA LOOP AND RECORD CHANGER MUST BE IN CABINET FOR THE FOLLOWING				
3	Short wire placed near	1,620 kc	Extreme R. H. end (gang open)	C1B-T (osc.)
4	loop for radiated	1,400 kc	1,400 kc	C5 (ant.)
5	signal	600 kc	600 kc Signal	L3 (Rock Gang)
6	Repeat steps 3, 4 & 5 if necessary			

Critical Lead Dress

1. Dress C15 (.022 mfd. at grid of phase inverter) over tube socket away from filament leads.
2. Keep all filament leads close to chassis.
3. Keep leads of R26 (270 ohms at I-F amplifier cathode) short as possible.
4. Connect outside foil of all capacitors as indicated in schematic diagram.
5. Dress output plate bypasses, C19 and C20, as near chassis as possible.

Dial Pointer Adjustment.—Rotate tuning condenser fully counterclockwise (plates fully meshed). Adjust indicator pointer so that it is 3 1/16" from the left hand edge of the dial back plate.

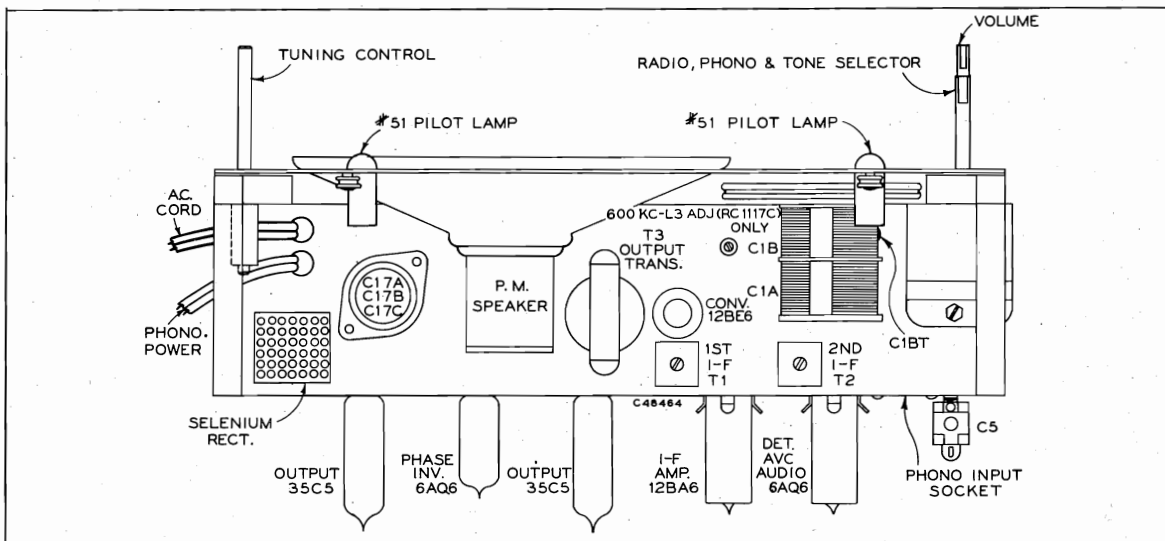

Tube and Trimmer Locations

MODEL 2US7,
Ch. RC1117A, C

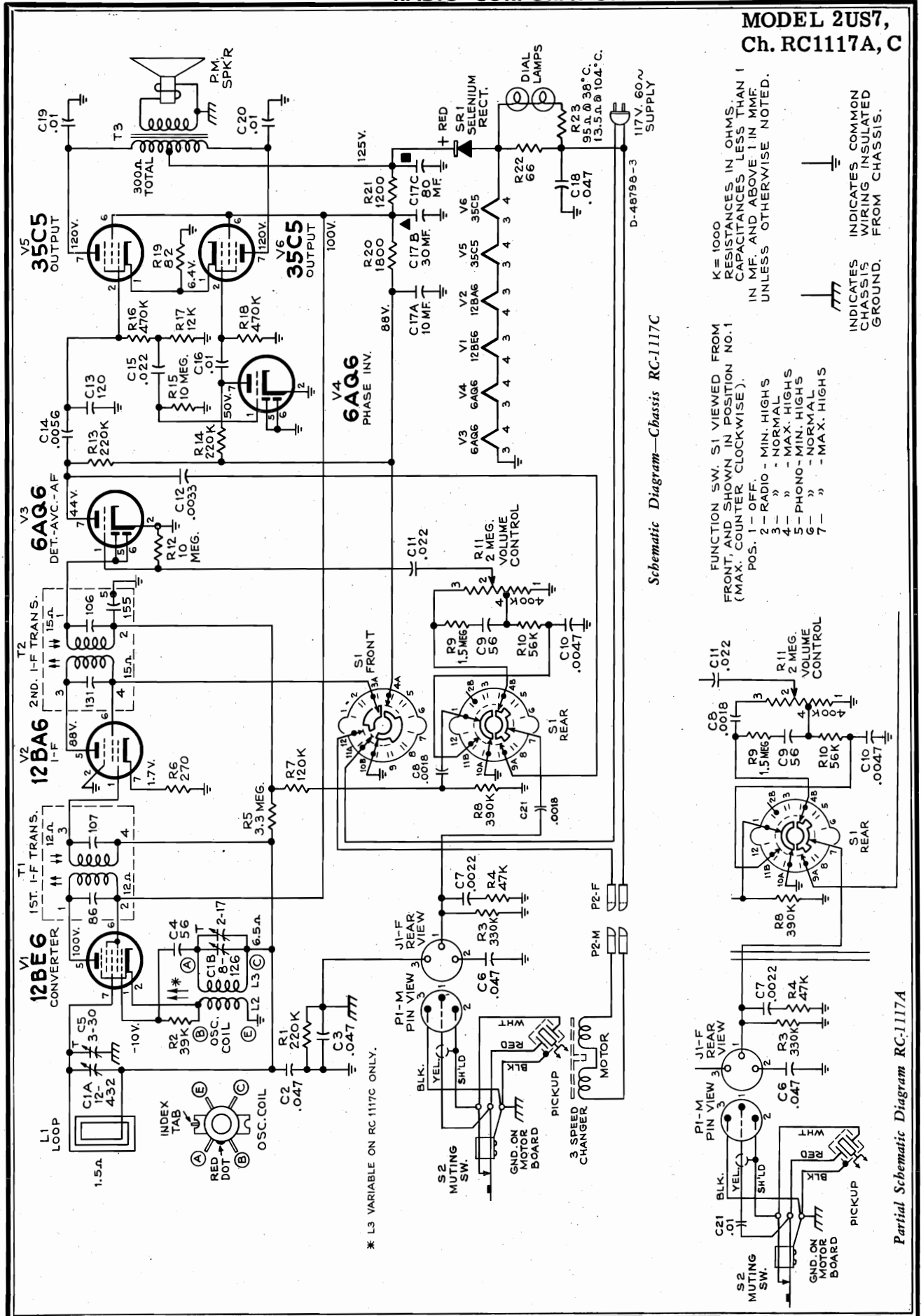

Schematic Diagram—Chassis RC-1117C

K = 1000
RESISTANCES IN OHMS.
CAPACITANCES LESS THAN 1
IN MF. AND ABOVE 1 IN MMF
UNLESS OTHERWISE NOTED.

INDICATES COMMON
CHASSIS WIRING INSULATED
FROM CHASSIS.

FUNCTION SW. S1 VIEWED FROM
FRONT, AND SHOWN IN POSITION NO.1
(MAX. COUNTER CLOCKWISE).

- 1 - OFF.
- 2 - RADIO - MIN. HIGHS
- 3 - " - NORMAL
- 4 - " - MAX. HIGHS
- 5 - PHONO - MIN. HIGHS
- 6 - " - NORMAL
- 7 - " - MAX. HIGHS

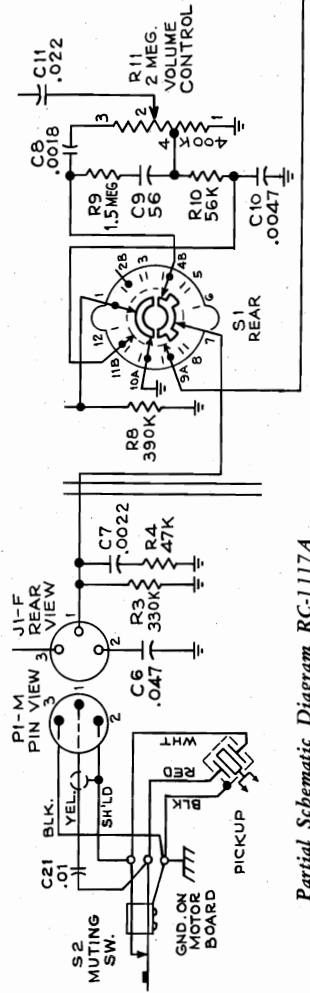

Partial Schematic Diagram RC-1117A

MODEL 2US7,
Ch. RC1117A, C

STOCK No.	DESCRIPTION	STOCK No.	DESCRIPTION
CHASSIS ASSEMBLIES RC1117A, RC1117C		503356	56,000 ohms, ±10%, ½ watt, R10
76867	Capacitor—Variable tuning capacitor complete with drive drum, C1A, C1B	503412	120,000 ohms, ±10%, ½ watt, R7
93603	Capacitor—Ceramic, 56 mmf., C9	504422	220,000 ohms, ±20%, ½ watt, R1, R13, R14
77116	Capacitor—Ceramic, 56 mmf., C4	503433	330,000 ohms, ±10%, ½ watt, R3
76347	Capacitor—Ceramic, 120 mmf., C13	503439	390,000 ohms, ±10%, ½ watt, R8
76872	Capacitor—Adjustable trimmer, 2.5—30 mmf., C5	503447	470,000 ohms, ±10%, ½ watt, R16
73013	Capacitor—Electrolytic comprising 1 section of 80 mfd., 150 volts, 1 section of 30 mfd., 150 volts and 1 section of 10 mfd., 150 volts, C17A, C17B, C17C	504447	470,000 ohms, ±20%, ½ watt, R18
73851	Capacitor—Tubular, paper, .0018 mfd., 1600 volts, C8, C21 (RC1117C only)	503515	1.5 megohm, ±10%, ½ watt, R9
73595	Capacitor—Tubular, paper, .0022 mfd., 600 volts, C7	504533	3.3 megohm, ±20%, ½ watt, R5
73795	Capacitor—Tubular, paper, .0033 mfd., 400 volts, C12	504610	10 megohm, ±20%, ½ watt, R12, R15
73920	Capacitor—Tubular, paper, .0047 mfd., 600 volts, C10	76869	Shaft—Tuning knob shaft
73788	Capacitor—Tubular, paper, .0056 mfd., 400 volts, C14	76870	Shield—Tube shield for V1, V2, V3
73561	Capacitor—Tubular, paper, .01 mfd., 400 volts, C16, C19, C20	74697	Socket—Dial lamp socket
73562	Capacitor—Tubular, paper, .022 mfd., 400 volts, C11, C15	51955	Socket—Tube socket, 7 pin, miniature, moulded, saddle-mounted
73553	Capacitor—Tubular, paper, .047 mfd., 400 volts, C2, C3, C6	77115	Socket—Tube socket, 7 pin, miniature, moulded
75071	Capacitor—Tubular, moulded paper, .047 mfd., 400 volts, C18	76368	Spring—Drive cord spring
73935	Clip—Mounting clip for I.F. transformer	76873	Switch—Function switch less volume control, S1
76866	Coil—Oscillator coil, L2, L3	77113	Terminal—Phono lead assembly terminal (knife) disconnect type)
36422	Connector—3 contact female connector for phono cable, J1	74918	Transformer—First I.F. transformer complete with adjustable cores, T1
74192	Connector—3 contact male connector for shielded pickup cable, P1	73037	Transformer—Second I.F. transformer complete with adjustable cores, T2
77114	Connector—Single contact male connector for loop lead	77122	Transformer—Output transformer, T3
76874	Control—Volume control, R11	33726	Washer—"C" washer for tuning knob shaft (2 req'd)
72953	Cord—250' Drive Cord Reel (approx. 54" required)	SPEAKER ASSEMBLIES	
70392	Cord—Power cord and plug	76875	Speaker—5" x 7" P.M. speaker complete with cone and voice coil (3.2 ohms)
74838	Grommet—Power cord strain relief (1 set)	MISCELLANEOUS	
72283	Grommet—Rubber grommet to mount variable tuning capacitor (3 req'd)	76876	Back—Cabinet back and antenna loop assembly (L1)
11765	Lamp—Dial lamp—Mazda 51	77350	Cable—Cable and Capacitor assembly (includes C21) (For RC1117A only)
28452	Plate—Bakelite mounting plate for electrolytic	74273	Decal—"Victrola" decal
76865	Plate—Dial back plate complete with three (3) pulleys less dial	76877	Dial—Polystyrene dial scale
76868	Pointer—Station selector pointer	76588	Emblem—"RCA Victor" emblem
76871	Rectifier—Selenium rectifier, SR1	74225	Escutcheon—Dial escutcheon less dial
73038	Resistor—Wire wound, 66 ohms, 5 watts, R22	76878	Escutcheon—Function switch escutcheon
73072	Resistor—Normal value, 95 ohms, @ 38°C with negative temperature coefficient R23	76879	Escutcheon—Tuning control escutcheon
503082	Resistor—Fixed, composition: 82 ohms, ±10%, ½ watt, R19	76895	Foot—Rubber foot (4 req'd)
503127	270 ohms, ±10%, ½ watt, R6	72692	Hinge—Cabinet lid hinge
513212	1200 ohms, ±10%, 1 watt, R21	76882	Knob—Function switch knob—light gray
503218	1800 ohms, ±10%, ½ watt, R20	76881	Knob—Tuning control knob—(inner) light gray
503312	12,000 ohms, ±10%, ½ watt, R17	76883	Knob—Tuning control knob (outer)—light gray
503339	39,000 ohms, ±10%, ½ watt, R2	76880	Knob—Volume control knob—light gray
503347	47,000 ohms, ±10%, ½ watt, R4	71095	Nut—Speed nut to fasten dial escutcheon
		72765	Nut—Speed nut to fasten function switch or tuning control escutcheon
		76894	Nut—#10-32 spring nut for mounting stud
		30330	Spring—Retaining spring for volume control knob
		14270	Spring—Retaining spring for tuning control or function switch knobs
		76893	Stud—#10-32 x 1¼" special stud to mount changer in cabinet (2 req'd)
		71824	Stud—Stud and screw (1 set) for cabinet lid hinge
		77221	Support—Lid Support

APPLY TO YOUR RCA DISTRIBUTOR FOR PRICES OF REPLACEMENT PARTS

MODEL 2BX63,
Ch. RC-1115

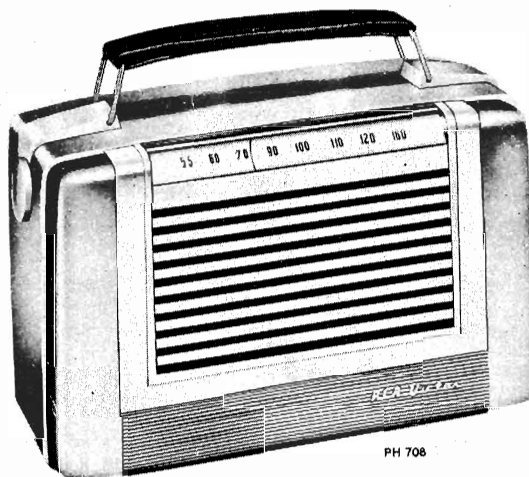

Specifications

Tuning Range 540-1,600 kc
Intermediate Frequency 455 kc
Power Supply Rating
Power Line Operation
 115 volts, d. c. or 50 to 60 cycles a. c. 15 watts
 or
Battery Operated using RCA VS 057W Battery
 (Average battery life—100 hrs. intermittent service)
Battery current "A" 50 ma., "B" 13 ma.

Weight (Approx.)
 Without battery .. 4 lb. 10 oz. With battery .. 7 lb. 12 oz.
Power Output
 Undistorted 170 watt
 Maximum 320 watt
Loudspeaker 4 in. P.M.
 Voice Coil impedance 3.2 ohms at 400 cycles
Cabinet Dimensions
 Height 8 in. Width 12½ in. Depth 5½ in.

Tube Complement

- (1) RCA 1T4 R.F. Amplifier
- (2) RCA 1R5 Converter
- (3) RCA 1T4 I.F.-Amplifier
- (4) RCA 1U5 Det.—AVC—1st A.F.
- (5) RCA 3V4 Output

A selenium rectifier is used.

To Remove Chassis:

1. Pull out battery and disconnect battery plug.
2. Unsolder the two loop antenna leads.
3. Remove the two large screws (under handle) in the top of the case.

To Remove Hinges

Remove back from cabinet as described at right. Spread the hinge apart to remove it from the cabinet back.

To Remove Cabinet Back

With the back fully open, grip the cabinet as illustrated. Insert a screwdriver under one hinge and pry the center of the hinge out of the opening in the cabinet while maintaining pressure on the back with the fingers and on the cabinet with the thumb. Repeat this procedure with the other hinge. Pull the back straight to the rear using both hands.

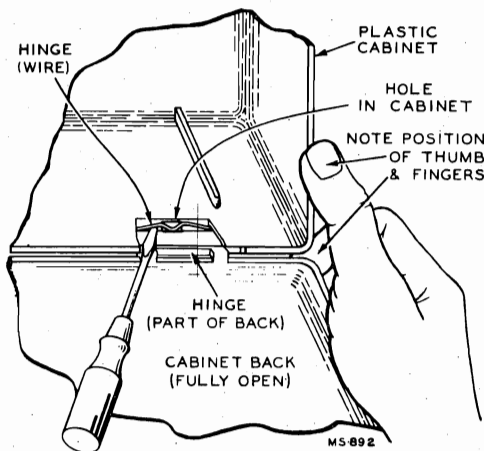

Removal of Cabinet Back

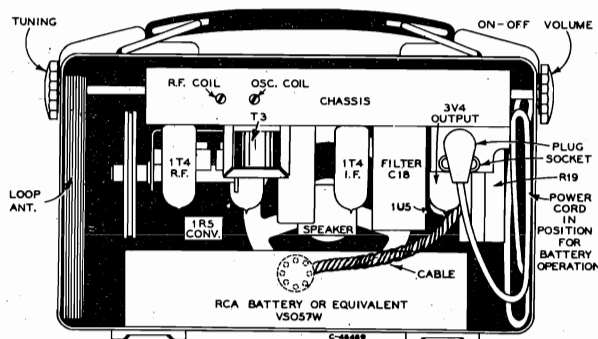

Rear View With Back Removed

MODEL 2BX63, Ch. RC-1115

Alignment Procedure

Output Meter Alignment—If this method is used, connect the meter across the voice coil and turn the receiver volume control to maximum.

Test Oscillator—For all alignment operations, connect the low side of the test oscillator to the receiver chassis and keep the oscillator output as low as possible to avoid AVC action.

Battery operation of the receiver is preferable during alignment; on AC operation an isolation transformer (117v./117v.) may be necessary for the receiver if the test oscillator is also AC operated.

Dial Pointer Position—With the tuning condenser fully meshed the center of the dial pointer should be in line with the score mark on the chassis.

Step	Connect High Side of Sig. Gen. to —	Sig. Gen. Output	Dial Pointer Setting	Adjust for Max. Output
1	Disconnect loop—remove chassis—remove bottom plate.			
2	Pin #6 of 1T4 I.F. Amplifier thru .005 mf.	455 kc	Quiet point near 1600 kc	2nd I.F. Trans. T2 Top & Bottom
3	Pin #6 of 1R5 Converter thru .005 mf.			1st I.F. Trans. T1 Top & Bottom
4	Replace bottom cover and install chassis in cabinet. Re-connect loop.			
5	Short wire placed near loop for radiated signal	1620 kc	min. cap.	1600 kc osc. trimmer C1-3T
6		1400 kc	1400 kc Signal	1400 kc r.f. & ant. trimmers*
7		Connect a 22,000 ohm resistor in parallel with r.f. tuning cond. C1-2		
8		600 kc	600 kc Signal	L4 osc. core* while rocking gang
9		Remove the 22,000 ohm resistor from r.f. tuning cond. C1-2.		
10		600 kc	600 kc Signal	L3 r.f. core
11	Repeat Steps 5, 6, 7, 8, 9 and 10.			

* The position of the battery affects loop inductance. The battery should be in place during steps 5 to 11.

Critical Lead Dress

1. Dress all filament leads next to chassis.
2. Use short pigtail leads on components to V1, Pin 6.
3. Dress gang leads direct to avoid excess lead length.
4. Dress loop leads away from gang tuning drum.
5. Dress capacitors C3, C4, C6 for RF shielding.
6. Use short pigtail lead on C21 to V3-2 and dress away from Pin 6.
7. Dress capacitors C13 and C17 direct and down to base.

CAUTION.—

Do not remove any tubes from the chassis with the set operating and the plug connected to the power line. Damage to tubes may result.

Dial-Indicator and Drive Mechanism

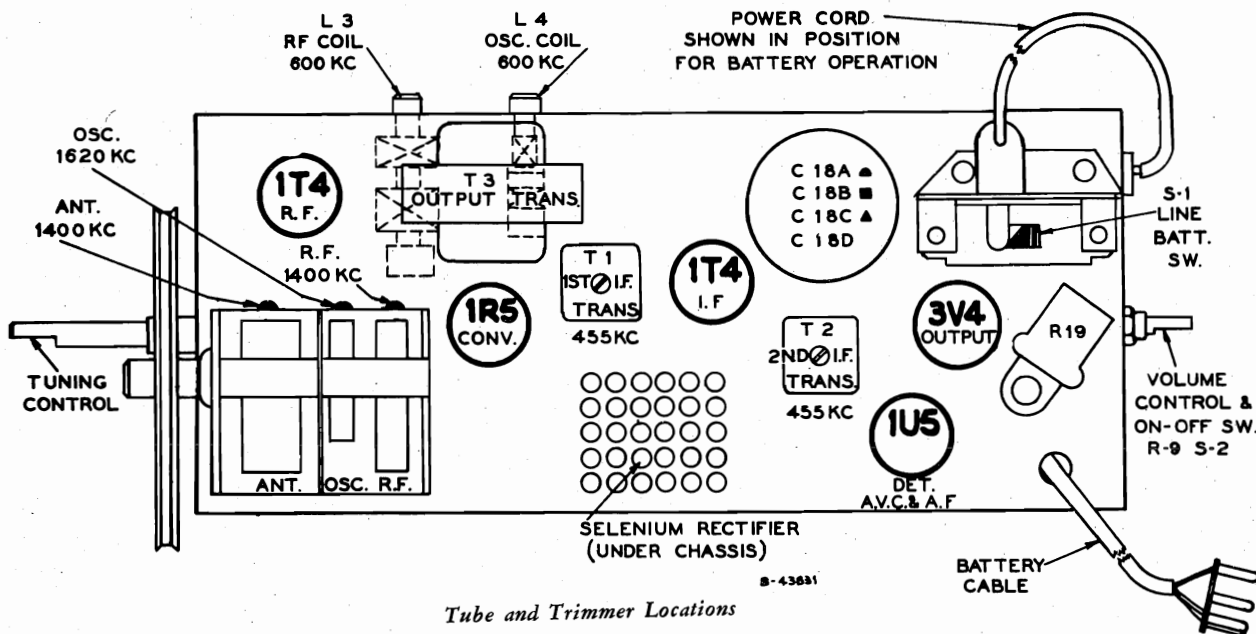
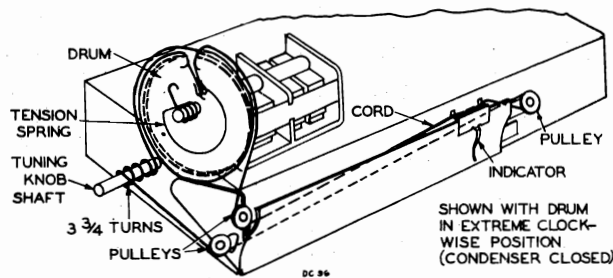

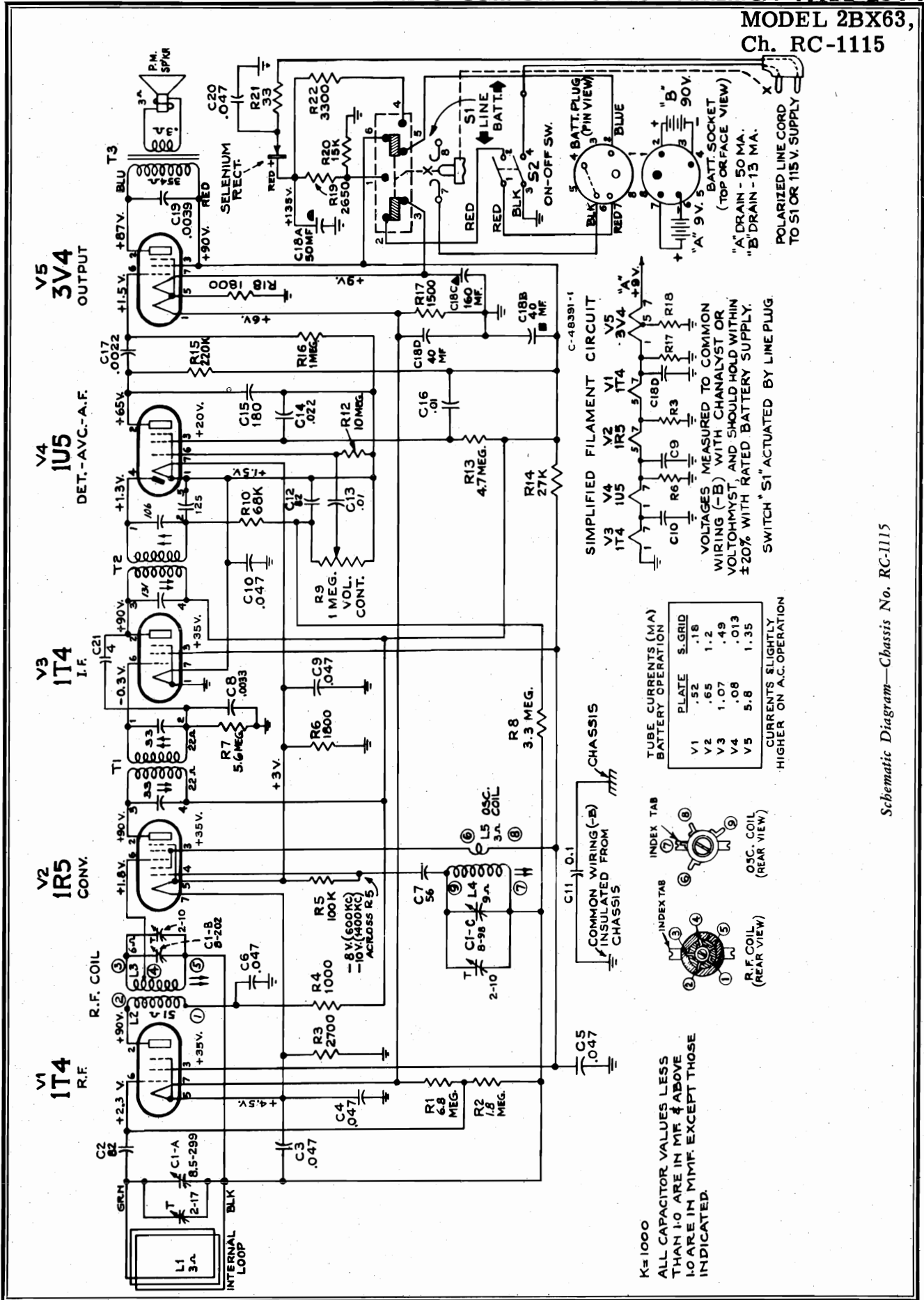

Schematic Diagram—Chassis No. RC-1115

MODEL 2BX63,
Ch. RC-1115

STOCK No.	DESCRIPTION	STOCK No.	DESCRIPTION
CHASSIS ASSEMBLIES RC-1115		513233	3300 ohms, ±10%, 1 watt R22
77054	Capacitor—Variable tuning capacitor complete with drive drum C1A, C1B, C1C	504315	15,000 ohms, ±20%, ½ watt R20
73153	Capacitor—Ceramic, 4 mmf. C21	503327	27,000 ohms, ±10%, ½ watt R14
39622	Capacitor—Mica, 56 mmf. C7	504368	68,000 ohms, ±20%, ½ watt R10
71514	Capacitor—Ceramic, 82 mmf. C2, C12	504410	100,000 ohms, ±20%, ½ watt R5
51416	Capacitor—Mica, 180 mmf. C15	503422	220,000 ohms, ±10%, ½ watt R15
76659	Capacitor—Electrolytic comprising 1 section of 50 mfd., 150 volts, 1 section of 40 mfd., 150 volts, 1 section of 160 mfd., 25 volts and 1 section of 40 mfd., 25 volts C18A, C18B, C18C, C18D	504510	1 megohm, ±20%, ½ watt R16
73595	Capacitor—Tubular, paper, .0022 mfd., 600 volts ... C17	503518	1.8 megohm, ±10%, ½ watt R2
73795	Capacitor—Tubular, paper, .0033 mfd., 600 volts ... C8	503533	3.3 megohm, ±10%, ½ watt R8
73796	Capacitor—Tubular, paper, .0039 mfd., 600 volts ... C19	504547	4.7 megohm, ±20%, ½ watt R13
73561	Capacitor—Tubular, paper, .01 mfd., 400 volts C13, C16	503556	5.6 megohm, ±10%, ½ watt R7
73562	Capacitor—Tubular, paper, .022 mfd., 400 volts ... C14	503568	6.8 megohm, ±10%, ½ watt R1
73558	Capacitor—Tubular, paper, .047 mfd., 200 volts C4, C5, C9, C10	504610	10 megohm, ±20%, ½ watt R12
73553	Capacitor—Tubular, paper, .047 mfd., 400 volts C3, C6	73117	Socket—Tube socket, 7 pin, miniature
75071	Capacitor—Tubular, moulded paper, .047 mfd., 400 volts C20	76368	Spring—Drive cord spring
73551	Capacitor—Tubular, paper, oil impregnated, 0.1 mfd., 400 volts C11	71039	Switch—"Line-Battery" switch S1
73935	Clip—Mounting clip for I.F. transformer	73129	Transformer—First I.F. transformer complete with adjustable cores T1
73114	Coil—Oscillator coil complete with adjustable core L4, L5	75487	Transformer—Second I.F. transformer complete with adjustable cores T2
74992	Coil—RF coil complete with adjustable core ... L2, L3	71047	Transformer—Output transformer T3
71041	Connector—5 contact male connector or battery cable	33726	Washer—"C" washer for tuning knob shaft
72776	Connector—Single contact pin connector or output transformer leads (2 req'd)	SPEAKER ASSEMBLIES 971495-7W RL-108B10	
75474	Connector—Single contact male connector for output transformer leads	77055	Speaker—4" P.M. speaker complete with cone and voice coil (3.2 ohms)
74285	Control—Volume control and power switch ... R9, S2	MISCELLANEOUS	
72953	Cord—250' Drive Cord Reel (approx. 50" required)	77068	Antenna—Antenna loop assembled to polystyrene frame and support L1
70022	Cord—Power cord and plug	77060	Back—Cabinet back—polystyrene—complete with strikes
77051	Dial—Metal dial scale complete with (3) pulleys	77061	Cap—Carrying handle cap and chassis support
74838	Grommet—Power cord strain relief (1 set)	77065	Case—Case front—less handle, handle support, caps, links and chassis mounting screw
72283	Grommet—Rubber grommet for mounting variable capacitor	77064	Emblem—"RCA Victor" emblem
18469	Plate—Bakelite mounting plate for electrolytic	77057	Eyelet—Metal eyelet for mounting loop assembly
77053	Pointer—Station selector pointer	77066	Grille—Metal grille
72602	Pulley—Drive cord pulley	77056	Grommet—Rubber grommet for mounting loop assembly
74322	Rectifier—Selenium rectifier	77063	Handle—Carrying handle
74319	Resistor—Wire wound, 2650 ohms, 7 watts R19	74790	Hinge—Cabinet hinge (2 req'd)
514033	Resistor—Fixed, composition:— 33 ohms, ±20%, 1 watt R21	77248	Knob—Control knob
504210	1000 ohms, ±20%, ½ watt R4	77062	Link—Carrying handle link
503215	1500 ohms, ±10%, ½ watt R17	77013	Nut—Speed nut for fastening "RCA Victor" emblem
503218	1800 ohms, ±10%, ½ watt R6, R18	76671	Screw—#6 x ½" cross recessed self-tapping round head screw for mounting loop
503227	2700 ohms, ±10%, ½ watt R3	77058	Screw—#8-32 x 7/16" cross recessed pan head machine screw for mounting loop
		74734	Spring—Spring clip for knobs
		77467	Washer—Knob washer—felt
		77067	Window—Clear vinylite dial window

APPLY TO YOUR RCA DISTRIBUTOR FOR PRICES OF REPLACEMENT PARTS

MODEL 35QU,
Ch. RC-1054K

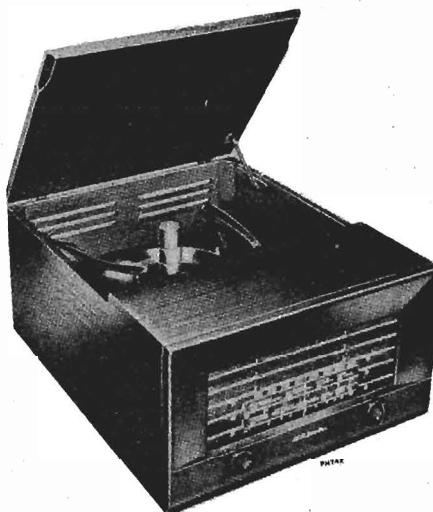

Specifications

Tuning Ranges

Standard Broadcast ("A" Band) . . . 520-1605 kc. (576-186 m.)
Medium Wave ("B" Band) 2.3-7 mc. (131-42.8 m.)
Short Wave ("C" Band) 7.0-22 mc. (42.8-13.7 m.)

Intermediate Frequency 455 kc.

Tube Complement

- (1) RCA-12BE6 Converter
- (2) RCA-6BJ6 I. F. Amplifier
- (3) RCA-12AV6 Det.-A.V.C.-A.F. Amp.
- (4) RCA-50L6GT Output
- (5) RCA-35W4 Rectifier

Power Supply

- 1. 105-125 v. 60 cycles A.C. 50 watts
- 2. 210-250 v. 60 cycles A.C. 55 watts
- 3. 105-125 v. 25 cycles A.C. 55 watts

Note: Instruments having power supply #1 or #2 may be converted to 50 cycle operation by the addition of a conversion spring sleeve to the record changer motor shaft.

Instruments having power supply #2 employ a step-down transformer but the power cord which extends from the chassis may be connected direct to a 117 v. A.C. power supply.

Record Changer

930409-6 for 60 or 50 cycle operation
930409-4 for 25 cycle operation
Turntable speed 33 $\frac{1}{3}$, 45 or 78 r.p.m.
Record capacity Up to fourteen 7 inch RCA type
or twelve 10 inch, or ten 12 inch,
or ten 10 in. and 12 in. intermixed.

Pickup (Stock No. 162A001) . . . Ceramic with replaceable styli

Tuning Drive Ratio 14:1 (7 turns of knob)

Cabinet Dimensions (overall)

Height 10 $\frac{5}{8}$ " (27 cm.)
Width 16 $\frac{5}{16}$ " (42 cm.)
Depth 22 $\frac{1}{2}$ " (57 cm.)

Weight 29 lbs. (13.2 kg.)

Loudspeaker

Size and Type 6 $\frac{1}{2}$ " (16 cm.) P.M.
V.C. Impedance 3.2 ohms at 400 cycles

Power Output

Undistorted 1.0 watt
Maximum 1.8 watt

Alignment Procedure

Test-Oscillator—For all alignment operations, connect the low side of the test-oscillator to the receiver chassis, and keep the oscillator output low to avoid a-v-c action.

Note: If the test-oscillator is a-c operated, it may be necessary to use an isolation transformer (117v./117v.) for the receiver during alignment and connect the low side of the test-oscillator to common wiring—reversal of the plug may reduce hum.

Calibration Scale on Indicator-Drive-Cord Drum—The tuning dial is fastened in the cabinet and cannot be used for reference during alignment, therefore a calibration scale is attached to the indicator-drive-cord drum which is mounted on the shaft of the gang condenser. The setting of the gang condenser is read on this scale, which is calibrated in degrees.

As the first step in r-f alignment, check the position of the drum. The "180°" mark on the drum scale must be vertical and directly over the center of the gang-condenser shaft when the plates are fully meshed.

Pointer for Calibration Scale—Improvise a pointer for the calibration scale by fastening a piece of wire to the gang-condenser frame, and bend the wire so that it points to the "180°" mark on the calibration scale when the plates are fully meshed. The correct setting of the gang in degrees, for each alignment frequency, is given in the alignment table.

Dial-Indicator Adjustment—After fastening the chassis in the cabinet, attach the dial indicator to the drive cable with indicator at the end calibration mark, and gang condenser fully meshed. The indicator has a clip for attachment to the cable.

Step	Connect high side of test osc. to—	Tune test osc. to—	Range switch	Turn radio dial to—	Adjust for max. output
1	6BJ6 grid (Pin No. 1) in series with .01 mf	455 kc	A	Quiet point near 600 kc	T-2 top and bottom
2	12BE6 grid (in No. 7) Pin series with .01 mf				T-1* top and bottom
3	Antenna lead in series with 220 mmf	1400 kc	A	1400 kc 30°	C10 osc. C6-B ant.
4		600 kc		600 kc 145°	L7 osc. (rock gang)
5	Repeat steps 3 and 4				
6	Antenna lead in series with 300 ohms	6.1 mc	B	6.1 mc 30.3°	C9 osc.† C4 ant.
7		18.2 mc	C	18.2 mc 36°	C8 osc.† C3 ant.‡

* Do not readjust T-2.

† If two peaks are found—adjust at minimum capacity peak.

‡ Rock gang while adjusting—use maximum capacity peak.

NOTE: Oscillator tracks above signal on all bands.

MODEL 35QU,
Ch. RC-1054K

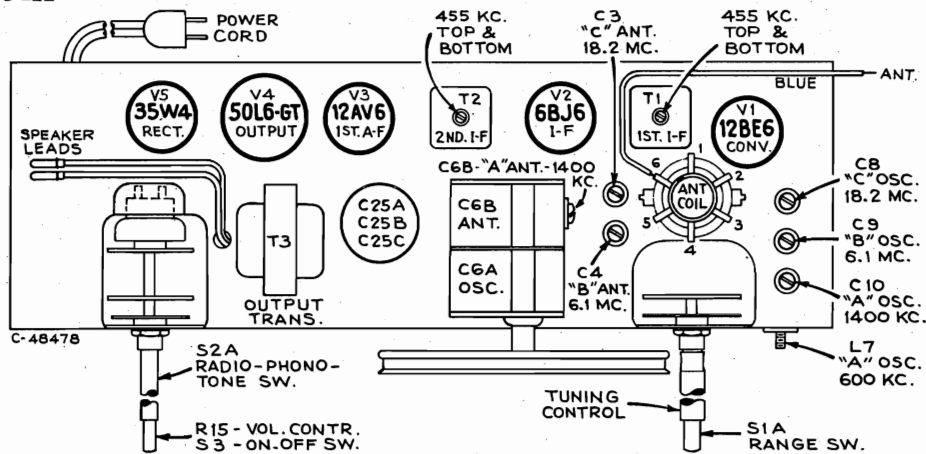

Tube and Trimmer Locations

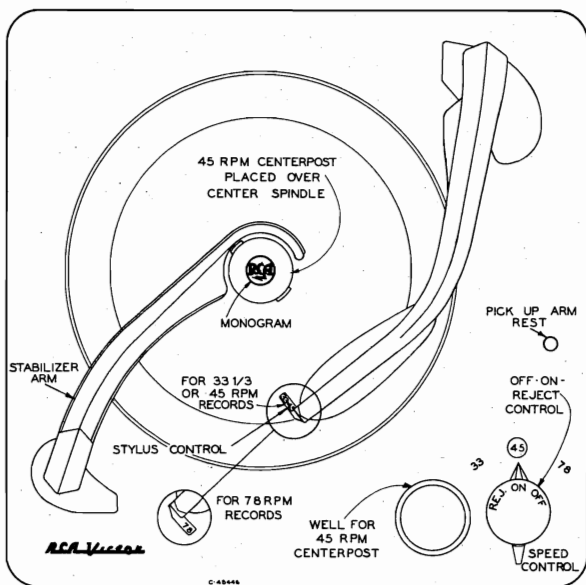

Critical Lead Dress

1. Dress C2 away from antenna coil windings.
2. Keep body of C15 away from chassis base.
3. All wires from the antenna and oscillator coils to the band switch are critical for length and should not be changed.
4. Dress any slack in lead from oscillator coil (C band secondary terminal) toward end of chassis.
5. Dress (C14-R3) away from chassis base.
6. Dress output plate lead next to chassis keeping it under -B and +B leads.
7. Dress phono cable under C29.
8. Dress R20 next to rear chassis apron.



KC 550 600 700 800 1000 1200 1400 1600

DELHI · GUATEMALA	CARACAS · MADRAS	CARTAGENA	MOSCOW
120 CALCUTTA · BOMBAY	90 MARACAIBO · ROME	60 REYKJAVIK	49 LONDON

M MC 2.5 3 4 5 6 7

VATICAN CITY	JOHANNESBURG	LISBON · HAVANA	MANILA	LONDON	HAVANA
41 SANTIAGO	RIO DE JANEIRO	25 GENEVA · PARIS	19 QUITO	16 N.Y.	13

M MC 8 9 10 12 14 16 18 20 22



DS-935697

Reduced Reproduction of Receiver Dial Scale and Corresponding 0-180° Calibration Scales

The corresponding position of the dial indicator for any setting of the calibration scale can be determined by drawing a line from this point on the bottom calibration scale to the same point on the top calibration scale. For example: 145° on the calibration scale corresponds to approximately 600 kc on "A" band, etc. Read instructions under "Alignment Procedures."

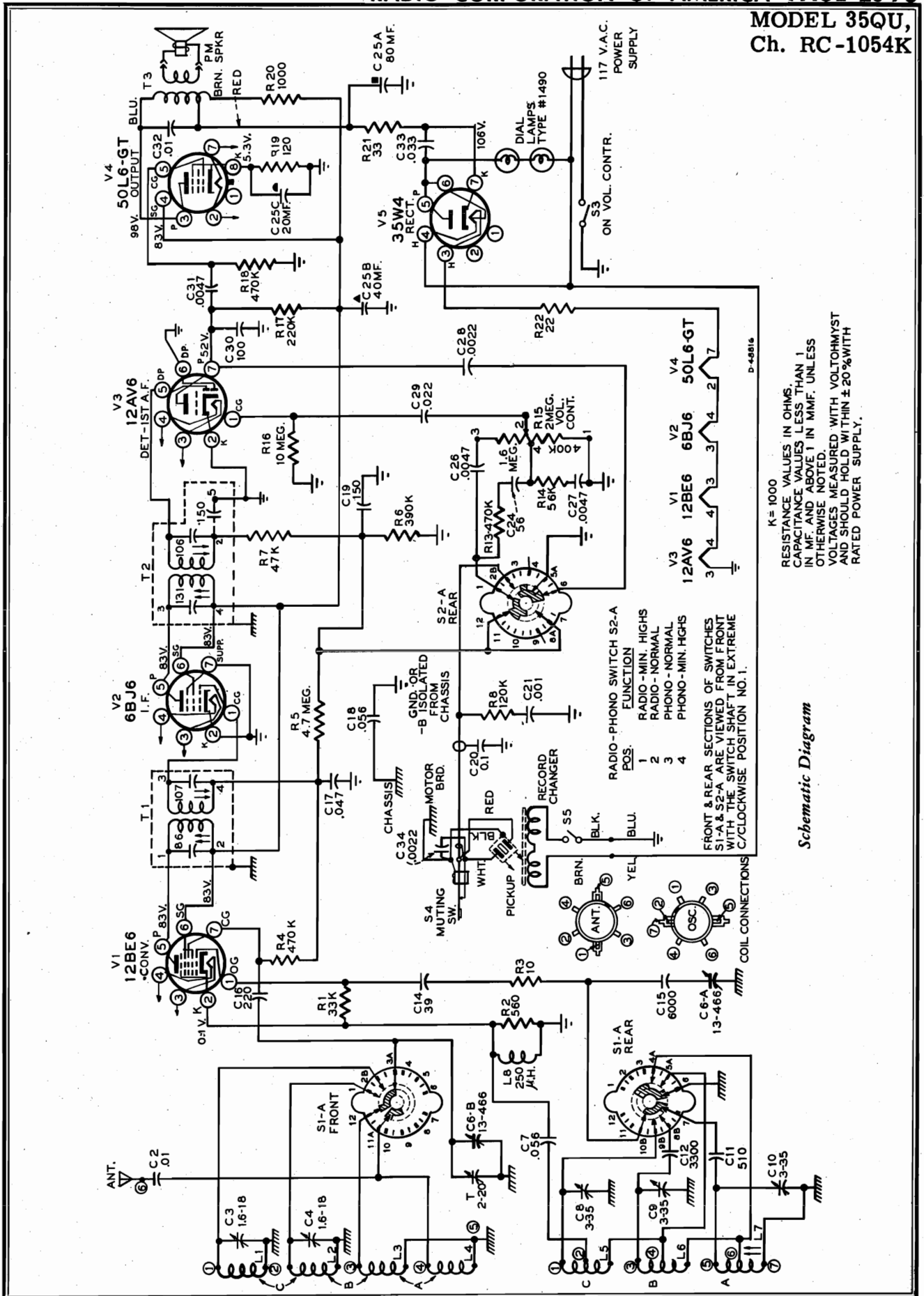

MODEL 35QU,
Ch. RC-1054K

STOCK No.	DESCRIPTION	STOCK No.	DESCRIPTION
CHASSIS ASSEMBLY RC-1054K			
S-6032	Bracket—Dial cord pulley bracket complete with one large pulley (left)	S-4624	390,000 ohms, 1/2 watt (R6)
S-6033	Bracket—Dial cord pulley bracket complete with one large pulley (right)	S-4476	470,000 ohms, 1/2 watt (R4, R18)
Fixed Capacitors:		S-6479	470,000 ohms, 1/2 watt (R13)
S-6634	Ceramic, 56 mmf (C24)	S-4478	4.7 megohm, 1/2 watt (R5)
S-6635	Ceramic, 100 mmf (C30)	S-5517	10 megohm, 1/2 watt (R16)
S-6636	Ceramic, 150 mmf (C19)	S-6651	Sleeve—Tuning control sleeve
S-6637	Ceramic, 220 mmf (C16)	S-4483	Socket—Tube socket—octal—for 50L6GT tube
S-6300	Mica, 510 mmf (C11)	S-6322	Socket—Tube socket—miniature for 12BE6 tube
S-4441	Mica, 3300 mmf (C12)	S-6652	Socket—Tube socket—miniature for 6BJ6, 12AV6 and 35W4 tubes
S-4442	Mica, 6000 mmf (C15)	S-6037	Socket—Dial lamp socket and lead assembly
S-6638	Molded paper, .001 mf, 600v. (C21)	S-5710	Spacer—Metal spacer for tuning condenser mounting (3 req'd)
S-4607	Molded paper, .0022 mf, 600v. (C28)	S-4485	Spring—Tension spring for tuning drive cord
S-4443	Molded paper, .0047 mf, 600v. (C26, C31)	S-6653	Switch—Tuning range switch (S1-A, S1-B)
S-5469	Molded paper, .0047 mf, 600v. (C27)	S-4487	Transformer—First I-F transformer (T1)
S-6326	Ceramic, .01 mf. (C2)	S-4488	Transformer—Second I-F transformer (T2)
S-4609	Molded paper, .01 mf, 600v. (C32)	S-6654	Transformer—Output transformer (T3)
S-4732	Molded paper, .022 mf, 400v. (C29)	S-6179	Washer—"C" washer to retain tuning control sleeve
S-6639	Molded paper, .033 mf, 1000v. (C33)	SPEAKER ASSEMBLY (STAMPED 970657-7, 8 or 9)	
S-4448	Molded paper, .047 mf, 200v. (C17)	S-6046	Cone—Cone and voice coil assembly
S-4449	Molded paper, .056 mf, 400v. (C7, C18)	S-6662	Speaker—6 1/2 inch P.M. speaker complete with cone and voice coil.
S-4634	Molded paper, .1 mf, 400v. (C20)	MISCELLANEOUS	
S-4452	Electrolytic, 30 mf and 40 mf at 150v. and 20 mf at 25v. (C25A, C25B, C25C)	S-6655	Capacitor—Molded paper, .0022 mf, 1000v. (C34)
S-4450	Capacitor—Trimmer capacitor, two sections of 1.6—18 mmf (C3, C4)	S-5734	Decal—"Victrola" decal
S-4516	Capacitor—Trimmer capacitor, three sections of 3-35 mmf (C8, C9, C10)	S-6656	Decal—Control function decal for front of cabinet (1 set)
S-6640	Capacitor—Variable tuning capacitor (C6-A, C6-B)	S-6657	Dial—Plastic dial scale
S-4453	Capacitor and Resistor—Assembly comprising 39 mmf capacitor and 10 ohm resistor (C14, R3)	S-6665	Emblem—"RCA Victor" emblem
S-4454	Clip—Mounting clip for I-F transformers	S-5735	Foot—Rubber foot for cabinet (4 req'd)
S-6641	Coil—"A-B-C" bands antenna coil (L1, L2, L3, L4)	S-4502	Grommet—Rubber grommet for chassis mounting (4 req'd)
S-6642	Coil—"A-B-C" bands oscillator coil (L5, L6, L7)	S-6043	Grommet—Rubber grommet for speaker mounting (4 req'd)
S-4457	Coil and Resistor—Assembly comprising 250 microhenry coil and 560 ohm resistor (L8, R2)	S-6658	Hinge—Cabinet lid hinge (2 req'd)
S-6643	Control—Volume control and tone switch (R15, S2-A)	S-6044	Indicator—Station indicating pointer
S-4458	Cord—Tuning drive cord (approx. 49 inches required)	S-6511	Knob—Radio-Phono switch control knob for walnut finish instruments
S-5463	Cord—Power line attachment cord	S-6512	Knob—Radio-Phono switch control knob for oak finish instruments
S-6311	Core—Adjustable core for oscillator coil	74963	Knob—Volume control and on-off switch knob for walnut finish instruments
S-4464	Grommet—Rubber grommet for tuning capacitor mounting (3 req'd)	S-9206	Knob—Volume control and on-off switch knob for oak finish instruments
S-4466	Insulation—Insulating plate for mounting electrolytic capacitor	74959	Knob—Tuning control knob for walnut finish instruments
S-6316	Nut—Speed nut for mounting of oscillator adjustable core.	S-9204	Knob—Tuning control knob for oak finish instruments
Resistors—Fixed, composition:		S-6513	Knob—Range switch control knob for walnut finish instruments
S-6644	22 ohms, 1 watt (R22)	S-6514	Knob—Range switch control knob for oak finish instruments
S-6645	33 ohms, 1 watt (R21)	S-4508	Lamp—Dial lamp—Mazda type #1490 (2 req'd)
S-6646	120 ohms, 1/2 watt (R19)	S-6659	Spacer—Metal spacer for chassis mounting (4 req'd)
S-6647	1000 ohms, 1 watt (R20)	S-6530	Spacer—Metal spacer for speaker mounting (4 req'd)
S-6648	33,000 ohms, 1/2 watt (R1)	S-5744	Stud—Internal thread stud for mounting lid hinge (8 req'd)
S-6392	47,000 ohms, 1/2 watt (R7)	S-4659	Support—Cabinet lid support
S-6649	56,000 ohms, 1/2 watt (R14)	S-6661	Transformer—234/117v. 50-60 cycle step-down transformer
S-6396	120,000 ohms, 1/2 watt (R8)		
S-6650	220,000 ohms, 1/2 watt (R17)		

APPLY TO YOUR RCA DISTRIBUTOR FOR PRICES OF REPLACEMENT PARTS

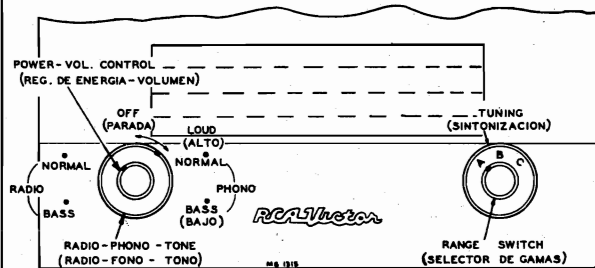

Radio Controls

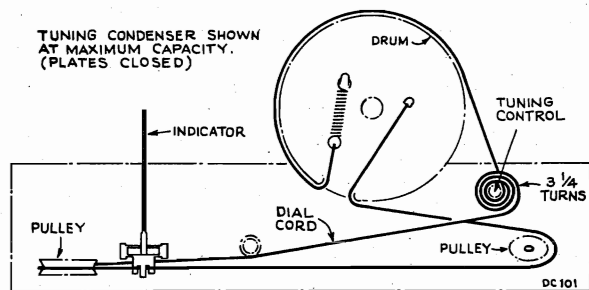

Dial-Indicator and Drive Mechanism

MODEL 2-XF-91, Ch.
RC1121, Forbes



Model 2-XF-91 "Forbes"
Maroon

SPECIFICATIONS

TUNING RANGE

Standard Broadcast (AM)..... 540-1600 kc
Frequency Modulation (FM)..... 88-108 mc
Intermediate Frequency (AM)..... 455 kc
Intermediate Frequency (FM)..... 10.7 mc

TUBE COMPLEMENT

(1) RCA 6BJ6 R.F. Amplifier
(2) RCA 19X8 Mixer-Oscillator
(3) RCA 12BA6 I.F. Amplifier
(4) RCA 12AU6 FM I.F. Amplifier
(5) RCA 12AU6 FM I.F. Amplifier
(6) RCA 12AL5 F.M. Detector
(7) RCA 12AV6 AM Det.-AVC-Audio
(8) RCA 35C5 Audio Output
RCA Stock No. 77519..... Selenium Rectifier

POWER SUPPLY RATING

115 volts, 50-60 cycles, or 115 volts d.c..... .35 watts

LOUDSPEAKER

Size and Type..... 5¼" P.M.
Voice Coil Impedance..... 3.2 ohms

AUDIO POWER OUTPUT

Undistorted 1.0 watt
Maximum 1.3 watts

TUNING DRIVE RATIO..... 9:1 (4½ turns of knob)

NET WEIGHT..... 8 lbs.

DIMENSIONS (Overall)

Height..... 8½" Width..... 13¾" Depth..... 7¼"

CIRCUIT DESCRIPTION

This instrument, an AM-FM table radio, has eight tubes, plus selenium rectifier. Individual dials are provided for AM and FM bands. RF circuits, contained on a two tube sub-chassis, include RF amplification for both bands and a combination mixer-oscillator circuit. The input circuit to the FM RF stage is broadbanded, and is tuned to the approximate FM band center at 100 mc. The mixer is pentode connected for AM operation; triode connected for FM operation. AM IF circuits use an IF amplifier and conventional diode detector with AVC. FM IF circuits include three IF amplifier stages and a discriminator detector. The two tube audio amplifier has an adjustable tone control circuit with combination bass and treble compensation. A hum-bucking circuit uses the tapped-winding output transformer. An inbuilt AM loop antenna, and line cord FM antenna, allow reception without the use of external antennas. A phono jack at the instrument rear permits the use of a record player attachment.

OPERATING INSTRUCTIONS

RADIO — Turn OFF-VOLUME control about half-way in a clockwise direction to turn receiver ON and provide for medium VOLUME. Allow a short warm-up period. Set FUNCTION control at desired service — AM or FM. Rotate TUNING control to move the pointers to the desired AM or FM frequency. Do not touch the pointers themselves. Adjust VOLUME and TONE controls as desired.

PHONOGRAPH — Connect attachment to PHONO jack at instrument rear. Switch the FUNCTION control to "PH" position. Turn on receiver and adjust VOLUME and TONE controls as desired.



Radio Controls

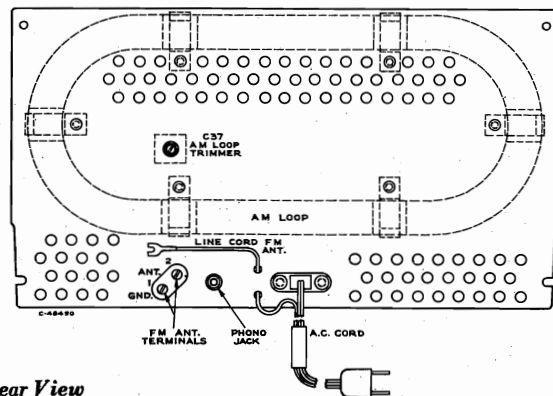

Rear View

MODEL 2-XF-91,
Ch. RC1121

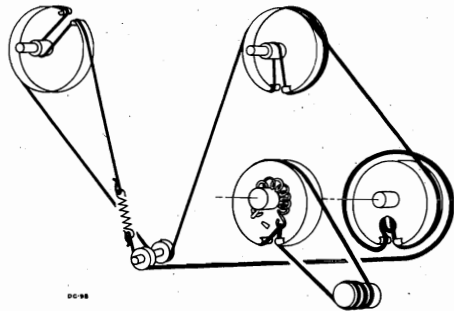

DIAGRAM OF DIAL CORD WITH GANG IN EXTREME COUNTER-CLOCKWISE POSITION (PLATES CLOSED)

Dial and Drive Cord Drive
ALIGNMENT PROCEDURE

ALIGNMENT INDICATORS:

An RCA VoltOhmyst or equivalent meter is necessary for measuring developed d-c voltage during FM alignment. Connections are specified in the alignment tabulation. An output meter is also necessary to indicate maximum audio output during AM alignment. Connect the output meter across the speaker voice coil. The RCA VoltOhmyst can also be used as an AM alignment indicator, either to measure audio output or to measure AVC voltage. When audio output is being measured, the volume control should be turned to maximum. Adjust tone control to mid-position.

SIGNAL GENERATOR:

For all alignment operations, connect the low side of the signal generator to the receiver chassis. If output measurement is used for AM alignment, the output of the signal generator should be kept as low as possible to avoid AVC action.

If an FM sweep generator is used for FM alignment, adjust for 10.7 mc, 0.4 mc sweep. Connect oscilloscope across C26, adjusting discriminator T6 top core for 10.7 mc crossover, and T6 bottom core for balanced peaks. Peak separation should be approximately 330 kc. When aligning the other FM tuned circuits, connect oscilloscope lead through a 220K resistor to pin 1 of V5. Follow alignment table sequence, adjusting for maximum gain and symmetrical curves.

Tube Socket Voltages

Tube Type and Function	Tube Element	Pin No.	AM	FM	Phono
V1 6BJ6 R.F. Amp.	Plate	5	94	92	92
	Screen	6	94	92	92
	Cathode	2	0.7	0.9	0.5
	Grid	1	-0.5	0	-0.6
V2 19X8 Mixer	Plate	9	75	80	80
	Screen	1	75	80	80
	Cathode	6	0	0	0
	Grid	7	-1.6	-2.3	-2.3
Osc.	Plate	3	85	85.6	74
	Grid	2	-3.3	-3	-0.3
	Cathode	6	—	—	—
V3 12BA6 I.F. Amp.	Plate	5	94	92	90
	Screen	6	94	92.3	90
	Cathode	7	0.8	0.9	0.8
	Grid	1	-0.4	-0.2	-0.2
V4 12AU6 2nd I.F. Amp. (F.M.)	Plate	5	95	93.5	92
	Screen	6	95	94.1	92
	Cathode	7	0.8	0.8	0.8
	Grid	1	0	0	0
V5 12AU6 3rd I.F. Amp. (F.M.)	Plate	5	74	73	72
	Screen	6	74	73	72
	Cathode	7	0.3	0.3	0.4
	Grid	1	-0.2	-0.4	-0.2
V6 12AL5 F.M. Det.	Plate	2	—	—	—
	Cathode	5	—	—	—
	Plate	7	—	—	—
	Cathode	1	—	—	—
V7 12AV6 A.M. Det. Audio Amp.	Plate	7	58	57	57
	Grid	1	-0.8	-0.8	-0.8
	Plate	5	-0.5	-0.3	-0.3
	(Diode)	—	—	—	—
V8 35C5 Audio Output	Plate	7	130	130	130
	Screen	6	96	94.5	94.5
	Cathode	1	5.1	5.0	5.0
	Grid	2-5	—	—	—

Rectifier output should be approximately 139 volts, 70 ma.

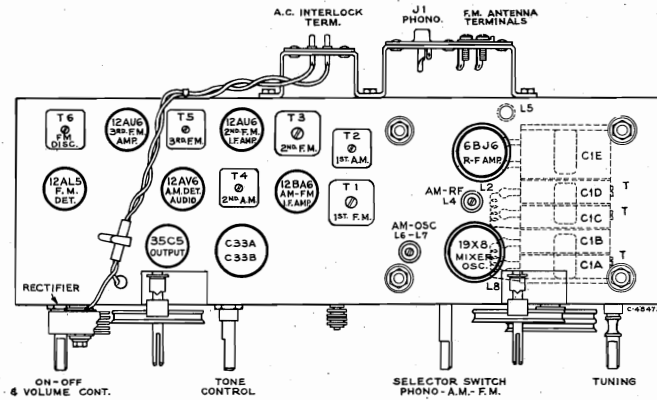

Tube and Trimmer Locations

AM Alignment

FUNCTION SWITCH IN AM POSITION

Steps	Connect high side of sig. gen. to—	Sig. gen. output	Turn radio dial to—	Adjust for peak output
1	Pin No. 1 of V3 in series with .01 mfd.	455 kc. (mod.)	Quiet point at high freq. end	T4 bottom core (sec.) T4 top core (pri.)
2	Tap lug 4 on AM RF coil			T2 bottom core (sec.) T2 top core (pri.)
3		1620 kc. (mod.)	1620 kc.	C1A-T (osc.)
4		1400 kc. (mod.)	1400 kc.	C37 (ant.) C1C-T (rf.)
5	Short wire placed near loop for radiated signal	600 kc. (mod.)	600 kc.	L6 (osc.) with 10,000 ohm resistor from C1C RF stator to gnd. (rocking gang)
6				L4 (RF) with the 10,000 ohms removed
7	Repeat steps 4, 5 and 6 until maximum gain is obtained			

FM Alignment

FUNCTION SWITCH IN FM POSITION—VOLUME CONTROL MINIMUM—TONE CONTROL CENTER

Steps	Connect high side of sig. gen. to—	Sig. gen. output	Turn radio dial to—	Adjust for max. output
1	Pin No. 1 of V5-12AU6	10.7 mc.	Quiet point at low frequency end	T6 top core for zero d.c. (across C26) T6 bottom core for maximum d.c. (junction of R24 and R25)
2	Pin No. 1 of V4-12AU6			†T5 top core
3	Pin No. 1 of V3-12BA6			T3 top core †T3 bottom core
4	C1D Stator			T1 top core †T1 bottom core
5		90 mc.	90 mc.	†FM osc. L8
6		106 mc.	106 mc.	†FM R.F. C1D-T
7		90 mc.	90 mc.	†FM R.F. L2
8	Repeat steps 6 and 7 until maximum gain is obtained			
9		100 mc.	100 mc.	†FM Ant. coil L5

*If necessary for accurate peaking, the winding in the same transformer not being peaked should be loaded with a 680 ohm resistor. †Connect VoltOhmyst to pin 1 of V5 through a 220K isolating resistor with 1/4 inch maximum exposed lead at grid terminal end. Output adjusted for 1 volt d.c. Dress VoltOhmyst lead away from input circuits.

Oscillator frequency is above signal frequency on both AM and FM

MODEL 2-XF-91,
Ch. RC1121

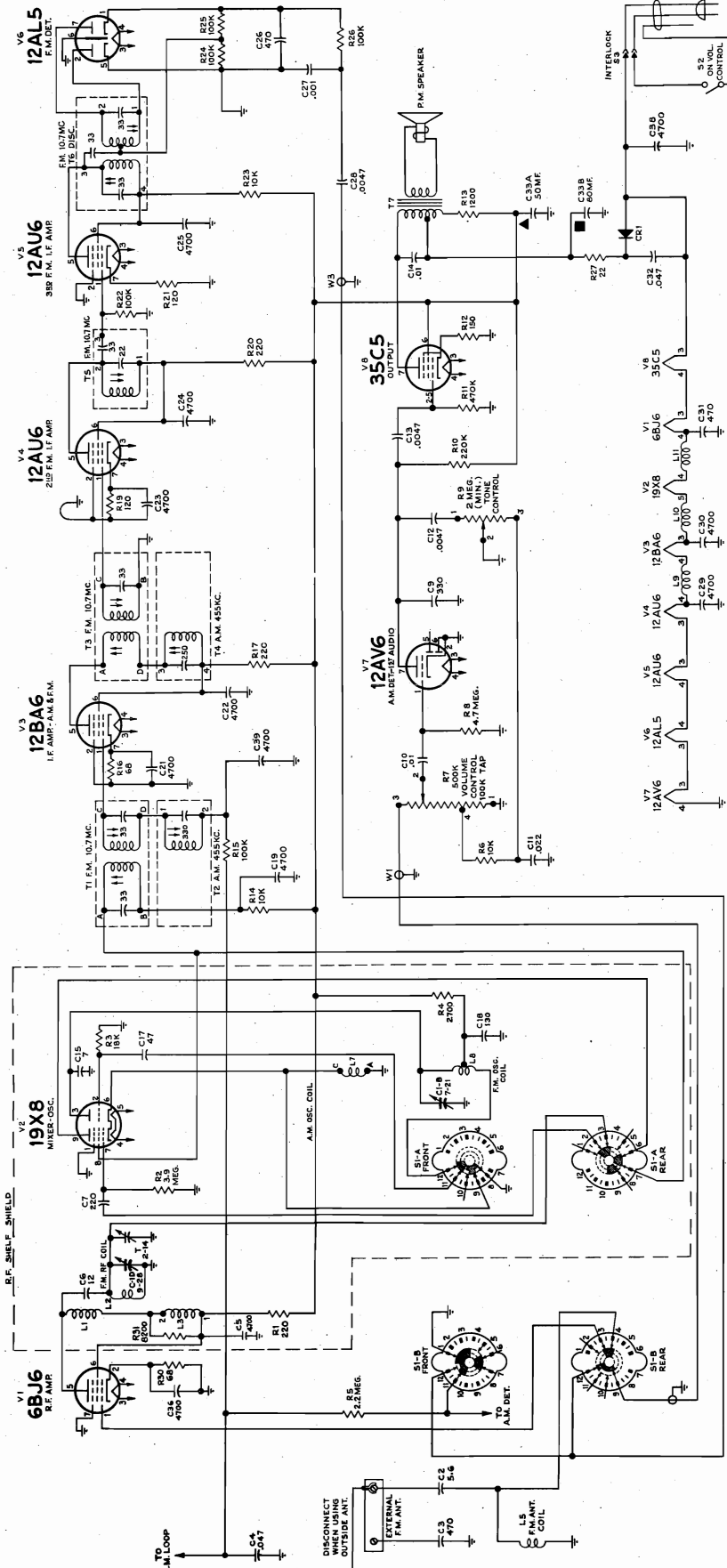

TO F.M. ANT. TERM. BOARD

EE 47935
K = 1000
ALL RESISTANCE VALUES IN OHMS AND ALL CAPACITANCE VALUES LESS THAN 1.0 IN MF. AND ABOVE 1.0 IN MMF. UNLESS OTHERWISE NOTED.

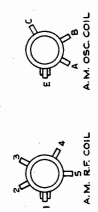

Simplified Schematic—"FM" Position

NOTES:
FRONT AND REAR SECTIONS OF FUNCTION SWITCH S1-A AND S1-B ARE VIEWED FROM FRONT WITH THE SWITCH SHAFT IN EXTREME COUNTER-CLOCKWISE POSITION #1

1	PHONO
2	A.M.
3	F.M.

MODEL 2-XF-91,
Ch. RC-1121

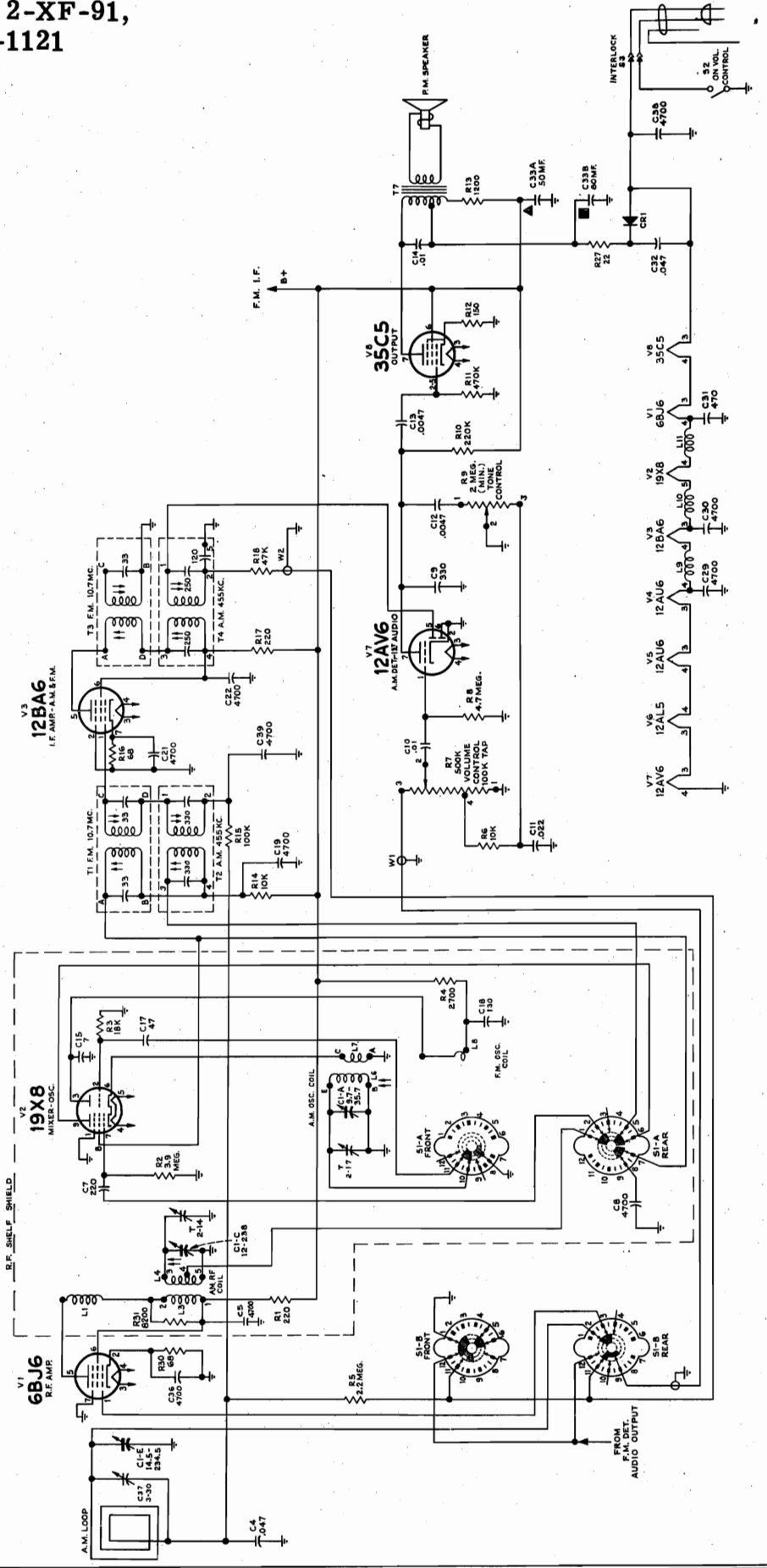

EE 47933

ALL RESISTANCE VALUES IN OHMS AND ALL CAPACITANCE VALUES LESS THAN 1.0 IN MF. AND ABOVE 1.0 IN MMF. UNLESS OTHERWISE NOTED.

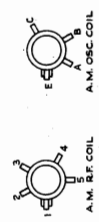

NOTES:
FRONT AND REAR SECTIONS OF FUNCTION SWITCH S1-A AND S1-B VIEWED FROM REAR. THE MAIN SHAFT IN EXTREME COUNTER-CLOCKWISE POSITION # (PHONO)
POSITION FUNCTION
1 AM
2 F.M.
3 PHONO

Simplified Schematic—"AM" Position

MODEL 2-XF-91,
Ch. RC1121

CRITICAL LEAD DRESS

1. All FM IF Transformer grid and plate leads should be short and direct as possible and kept low, near chassis.
2. C28 leads should be kept as short as possible.
3. C32 leads should be kept as short as possible.
4. R24 and R25 leads should be kept as short as possible on T6 terminal 6 side.
5. C27 should ground in hole near terminal 5 of V6 with short leads.
6. AM oscillator coil should not be tilted over toward function switch when wrapping short bus leads to switch.
7. Keep leads V5 pin 5, to T6 term 1, as short as possible and low near chassis.
8. Dress C28 down on chassis and against terminal board. Run filament lead between V5 and V6 on side of V6 socket opposite C28.
9. All ceramic button 4700 uuf condensers should have leads as short as possible.
10. Green lead from AM oscillator stator terminal to AM oscillator coil should be dressed against front of shield box and up above filament choke.
11. RF plate choke L1, should be dressed at least 1/8" away from AM R.F. coil L4 and at least 1/8" from shield.
12. Mixer grid condenser C7 should be dressed away from FM oscillator gang stator terminal and away from leads connecting to terminals 8 and 9 of V2 socket.
13. Filament chokes L10 and L11 should be raised a minimum of 1/16" above chassis.
14. Use varnished tubing only on choke and coupling cond. leads coming through shield partition slot.
15. Condenser C2 should have lead on antenna terminal end not more than 3/16" long to prevent possible contact of lead or body to "Hot" chassis.
16. Condensers C3 and C35 should use varnished tubing, not vinyl, to prevent breakthrough crossing chassis edge.
17. Oscillator grid condenser C17 should have short leads and be dressed away from filament choke L10.
18. Leads from loop terminal to chassis terminal board should have a minimum of three twists.

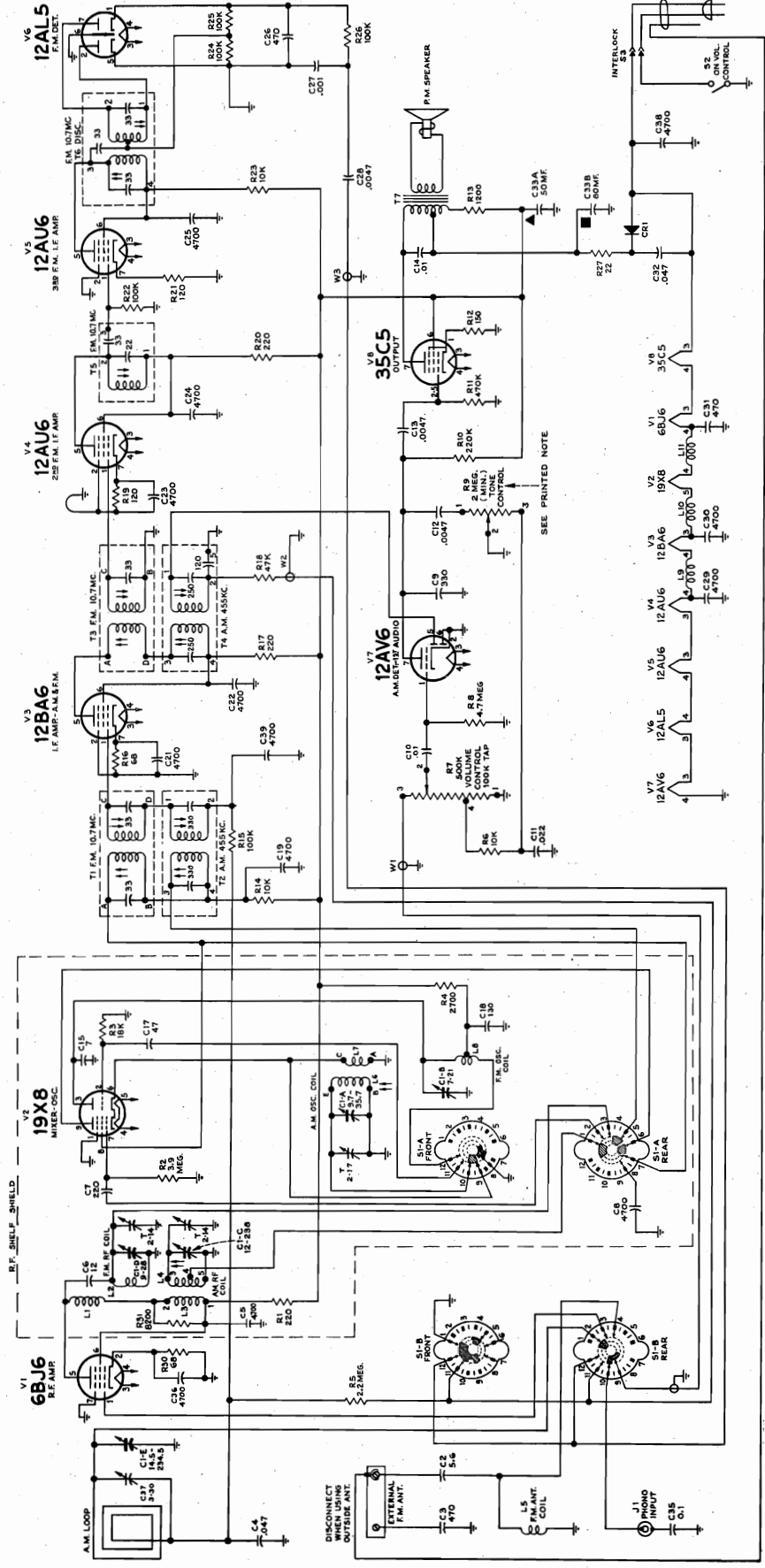

NOTES: 1. FRONT AND REAR SECTIONS OF FUNCTION SWITCH S1-A AND S1-B ARE VIEWED FROM FRONT WITH THE SWITCH SHAFT IN EXTREME COUNTER-CLOCKWISE POSITION #1 (PHONO) POSITION.
2. POSITION #1 (PHONO) POSITION.
3. POSITION #2 (F.M.) POSITION.

RESISTANCE VALUES IN OHMS UNLESS OTHERWISE NOTED.
CAPACITANCE VALUES IN MICROFARADS UNLESS OTHERWISE NOTED.

Acceptable value of R9 may be 2 to 50 megohms.

K = 1000
M = 1,000,000
U = 1,000,000,000

TO F.M. ANT. TERM. BOARD
EE 47938

MODEL 2-XF-91, Ch. RC1121

STOCK No.	PART DESCRIPTION	STOCK No.	PART DESCRIPTION
CHASSIS ASSEMBLIES			
RC1121			
77520	Bushing—Laminated bushing (3/8" long with shoulder) for station selector pointer pulley and shaft assembly.	77519	Rectifier—Selenium rectifier, 100 MA (CR1)
77522	Capacitor—Variable tuning capacitor (C1A, C1B, C1C, C1D, C1E, C1A-T, C1C-T, C1D-T)	76346	Resistor—Wire wound, 1200 ohms, 4 watts (R13)
70997	Capacitor—Fixed, ceramic, non-insulated, 5.6 mmf., ±1 mmf., 500 volts D.C. Temp. coef. = 0 (C2)	503022	Resistor—Fixed, composition:
77530	Capacitor—Fixed, ceramic, non-insulated, 7 mmf., ±.5 mmf., 500 volts D.C. Temp. coef. = 80 (C15)	503068	22 ohms, ±10%, 1/2 watt (R27)
33380	Capacitor—Fixed, ceramic, non-insulated, 12 mmf., ±5%, 500 volts D.C. Temp. coef. = 0 (C6)	503112	68 ohms, ±10%, 1/2 watt (R16, R30)
77531	Capacitor—Fixed, ceramic, non-insulated, 47 mmf., ±10%, 500 volts D.C. Temp. coef. = 0 (C17)	503115	120 ohms, ±10%, 1/2 watt (R19, R21)
77532	Capacitor—Fixed, ceramic, non-insulated, 130 mmf., ±2 1/2%, 500 volts D.C. Temp. coef. = -750 (C18)	503122	150 ohms, ±10%, 1/2 watt (R12)
39636	Capacitor—Fixed, mica, 220 mmf., 500 volts D.C. (C7)	503227	220 ohms, ±10%, 1/2 watt (R1, R17, R20)
75792	Capacitor—Fixed, ceramic, insulated, 330 mmf., ±20%, 500 volts D.C. High K (C9)	503282	2700 ohms, ±10%, 1/2 watt (R4)
76992	Capacitor—Fixed, mica, 470 mmf., 300 volts D.C. (C26, C31)	503310	8200 ohms, ±10%, 1/2 watt (R31)
39644	Capacitor—Fixed, mica, 470 mmf., 500 volts D.C. (C3)	503318	10,000 ohms, ±10%, 1/2 watt (R6, R14, R23)
73473	Capacitor—Fixed, ceramic, 4700 mmf., +100%, -0%, 500 volts D.C. High K disc (C5, C8, C19, C21, C22, C23, C24, C25, C29, C30, C36, C38, C39)	503347	18,000 ohms, ±10%, 1/2 watt (R3)
73520	Capacitor—Electrolytic comprising 1 section of 80 mfd., 150 volts and 1 section of 50 mfd., 150 volts (C33A, C33B)	503347	47,000 ohms, ±10%, 1/2 watt (R18)
77533	Capacitor—Fixed, miniature, tubular, paper, .001 mfd., 200 volts D.C. (C27)	502410	100,000 ohms, ±5%, 1/2 watt (R24, R25)
73920	Capacitor—Fixed, tubular, paper, .0047 mfd., 600 volts (C12, C13, C28)	503410	100,000 ohms, ±10%, 1/2 watt (R15, R22, R26)
73561	Capacitor—Fixed, tubular, paper, .01 mfd., 400 volts (C10)	503422	220,000 ohms, ±10%, 1/2 watt (R10)
73594	Capacitor—Fixed, tubular, paper, .01 mfd., 600 volts (C14)	503447	470,000 ohms, ±10%, 1/2 watt (R11)
73562	Capacitor—Fixed, tubular, paper, .022 mfd., 400 volts (C11)	503522	2.2 megohm, ±10%, 1/2 watt (R5)
73558	Capacitor—Fixed, tubular, paper, .047 mfd., 200 volts (C4)	503539	3.9 megohm, ±10%, 1/2 watt (R2)
75071	Capacitor—Fixed, tubular, moulded, .047 mfd., 400 volts (C32)	503547	4.7 megohm, ±10%, 1/2 watt (R8)
73551	Capacitor—Fixed, tubular, paper, 0.1 mfd., 400 volts (C35)	77527	Shaft—Tuning knob shaft
73935	Clip—Mounting clip for I.F. transformers	75192	Shield—Tube shield for V1
77538	Coil—Antenna coil—F.M. (L5)	76331	Shield—Tube shield for V2
77534	Coil—Choke coil (L1)	77087	Socket—Tube socket, 7 pin, miniature, moulded, saddle mounted for V1
77535	Coil—Choke coil (L9, L10, L11)	76336	Socket—Tube socket, 9 pin, miniature, moulded, saddle mounted for V2
77526	Coil—Oscillator coil—A.M.—complete with adjustable core (L6, L7)	73117	Socket—Tube socket, 7 pin, miniature, wafer for V3, V4, V5, V6, V7, V8
77537	Coil—Oscillator coil—F.M. (L8)	31970	Spring—Dial cord spring
77525	Coil—RF coil—A.M.—complete with adjustable core (L3, L4)	31418	Spring—Drive cord spring
77536	Coil—RF coil—F.M. (L2)	77524	Switch—Function switch (S1)
77528	Connector—Combination phono input connector and antenna terminal board (J1)	77517	Transformer—Output transformer (T7)
75474	Connector—Single contact male connector for speaker lead	77511	Transformer—Ratio detector transformer—complete with adjustable cores (T6)
77529	Connector—Two (2) contact male connector for power cord	76335	Transformer—First I.F. transformer—A.M.—complete with adjustable cores (T2)
77516	Control—Tone control (R9)	77514	Transformer—First I.F. transformer—F.M.—complete with adjustable cores (T1)
77515	Control—Volume control and power switch (R7, S2)	76328	Transformer—Second I.F. transformer—A.M.—complete with adjustable cores (T4)
72953	250' Dial Cord Reel—Dial cord (approx. 49" overall required)	77513	Transformer—Second I.F. transformer—F.M.—complete with adjustable cores (T3)
77523	Drive cord (approx. 11" overall required)	77512	Transformer—Third I.F. transformer—F.M.—complete with adjustable cores (T5)
77523	Drum—Variable tuning capacitor drive drum and hub	33726	Washer—"C" washer for station selector pointer pulley and shaft or tuning knob shaft
16058	Grommet—Rubber grommet for mounting RF shelf (4 required)	34373	Washer—"C" washer to fasten idler pulleys
77521	Nut—Speednut for station selector pointer pulley and shaft bushing	SPEAKER ASSEMBLIES	
72602	Pulley—Idler pulley for indicator cord (2 required)	971933-1	
77510	Pulley—Pulley and shaft (split) for station selector pointers	77539	Speaker—5 1/4" P.M. speaker complete with cone and voice coil (3.2 ohms)
		MISCELLANEOUS	
		77543	Antenna—Antenna loop and back assembly complete with power cord (includes C37)
		77543	Back—Cabinet back complete with loop, capacitor and power cord (includes C37)
		Y2467	Cabinet—Maroon plastic cabinet less "RCA Victor" emblem and function decal
		77544	Capacitor—Adjustable, mica trimmer, 3-30 mmf. (C37)
		77545	Cord—Power cord and plugs
		77542	Decal—Control function decal
		77033	Emblem—"RCA Victor" emblem
		77548	Knob—Function switch knob
		77547	Knob—Tuning control, tone control or volume control and power switch knob
		73203	Nut—Speednut to fasten "RCA Victor" emblem to cabinet.
		77541	Pointer—Station selector pointer—A.M.
		77540	Pointer—Station selector pointer—F.M.
		73992	Retainer—Knob retainer (knob to cabinet)
		76837	Spring—Retaining spring for knobs (knob to shaft)

APPLY TO YOUR RCA DISTRIBUTOR FOR PRICES OF REPLACEMENT PARTS

MODELS 2-XF-931, -932, -933, -934, -935, Ch. RC1121A, Townley

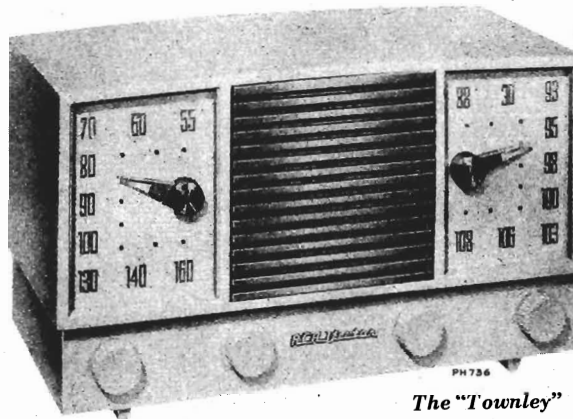

The "Townley"

2-XF-931
Maroon

2-XF-932
Ivory

2-XF-933
Green

2-XF-934
Red

2-XF-935
Beige

SPECIFICATIONS

TUNING RANGE

Standard Broadcast (AM)..... 540-1600 kc
Frequency Modulation (FM)..... 88-108 mc
Intermediate Frequency (AM)..... 455 kc
Intermediate Frequency (FM)..... 10.7 mc

TUBE COMPLEMENT

- (1) RCA 6BJ6 R.F. Amplifier
 - (2) RCA 19X8 Mixer-Oscillator
 - (3) RCA 12BA6 I.F. Amplifier
 - (4) RCA 12AU6 FM I.F. Amplifier
 - (5) RCA 12AU6 FM I.F. Amplifier
 - (6) RCA 12AL5 F.M. Detector
 - (7) RCA 12AV6 AM Det.-AVC-Audio
 - (8) RCA 35C5 Audio Output
- RCA Stock No. 77519..... Selenium Rectifier

POWER SUPPLY RATING

115 volts, 50-60 cycles..... 35 watts

CAUTION: DO NOT OPERATE ON D.C.

DIAL LAMPS..... 2 No. 47, 6-8 volts, 0.15 amp.

LOUDSPEAKER

Size and Type..... 5¼" P.M.
Voice Coil Impedance..... 3.2 ohms

AUDIO POWER OUTPUT

Undistorted 1.0 watt
Maximum 1.3 watts

TUNING DRIVE RATIO..... 9:1 (4½ turns of knob)

NET WEIGHT..... 8 lbs.

DIMENSIONS (Overall)

Height..... 8½" Width..... 13⁹/₁₆" Depth..... 7¾"

CIRCUIT DESCRIPTION

This instrument, an AM-FM table radio, has eight tubes, plus selenium rectifier. Individual dials are provided for AM and FM bands. RF circuits, contained on a two tube sub-chassis, include RF amplification for both bands and a combination mixer-oscillator circuit. The input circuit to the FM RF stage is broadbanded, and is tuned to the approximate FM band center at 100 mc. The mixer is pentode connected for AM operation; triode connected for FM operation. AM IF circuits use an IF amplifier and conventional diode detector with AVC. FM IF circuits include three IF amplifier stages and a discriminator detector. The two tube audio amplifier has an adjustable tone control circuit with combination bass and treble compensation. A hum-bucking circuit uses the tapped-winding output transformer. An inbuilt AM loop antenna, and line cord FM antenna, allow reception without the use of external antennas. A phono jack at the instrument rear permits the use of a record player attachment.

OPERATING INSTRUCTIONS

RADIO—Turn OFF-VOLUME control about half-way in a clockwise direction to turn receiver ON and provide for medium VOLUME. Allow a short warm-up period. Set FUNCTION control at desired service—AM or FM. Rotate TUNING control to move the pointers to the desired AM or FM frequency. Adjust VOLUME and TONE controls as desired.

PHONOGRAPH—Connect attachment to PHONO jack at instrument rear. Switch the FUNCTION control to "PH" position. Turn on receiver and adjust VOLUME and TONE controls as desired.



Radio Controls

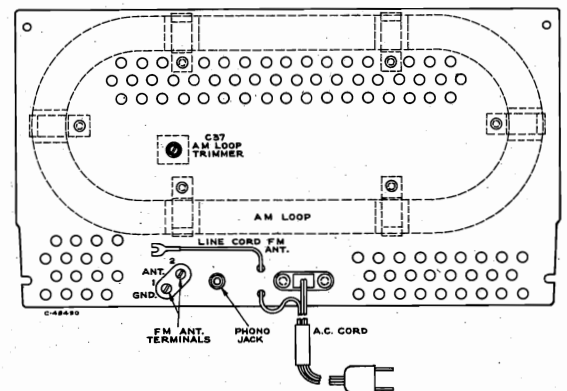

Rear View

MODELS 2-XF-931
Series, Ch. RC1121A

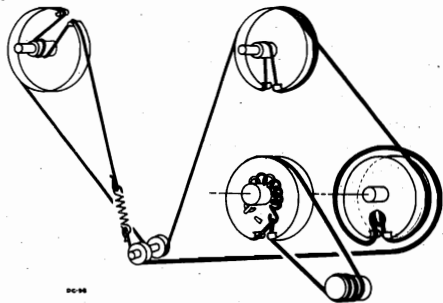

DIAGRAM OF DIAL CORD WITH GANG IN EXTREME COUNTER-CLOCKWISE POSITION (PLATES CLOSED)

Dial and Drive Cord Drive

ALIGNMENT PROCEDURE

ALIGNMENT INDICATORS:

An RCA VoltOhmyst or equivalent meter is necessary for measuring developed d-c voltage during FM alignment. Connections are specified in the alignment tabulation. An output meter is also necessary to indicate maximum audio output during AM alignment. Connect the output meter across the speaker voice coil. The RCA VoltOhmyst can also be used as an AM alignment indicator, either to measure audio output or to measure AVC voltage. When audio output is being measured, the volume control should be turned to maximum. Adjust tone control to mid-position.

SIGNAL GENERATOR:

For all alignment operations, connect the low side of the signal generator to the receiver chassis. If output measurement is used for AM alignment, the output of the signal generator should be kept as low as possible to avoid AVC action.

If an FM sweep generator is used for FM alignment, adjust for 10.7 mc, 0.4 mc sweep. Connect oscilloscope across C26, adjusting discriminator T6 top core for 10.7 mc crossover, and T6 bottom core for balanced peaks. Peak separation should be approximately 330 kc. When aligning the other FM tuned circuits, connect oscilloscope lead through a 220K resistor to pin 1 of V5. Follow alignment table sequence, adjusting for maximum gain and symmetrical curves.

Tube Socket Voltages

Tube Type and Function	Tube Element	Pin No.	AM	FM	Phono
V1 6BJ6 R.F. Amp.	Plate	5	94	92	92
	Screen	6	94	92	92
	Cathode	2	0.7	0.9	0.5
	Grid	1	-0.5	0	-0.6
V2 19X8 Mixer	Plate	9	75	80	80
	Screen	1	75	80	80
	Cathode	6	0	0	0
	Grid	7	-1.6	-2.3	-2.3
Osc.	Plate	3	85	85.6	74
	Grid	2	-3.3	-3	-0.3
	Cathode	6	—	—	—
	Grid	6	—	—	—
V3 12BA6 I.F. Amp.	Plate	5	94	92	90
	Screen	6	94	92.3	90
	Cathode	7	0.8	0.9	0.8
	Grid	1	-0.4	-0.2	-0.2
V4 12AU6 2nd I.F. Amp. (F.M.)	Plate	5	95	93.5	92
	Screen	6	95	94.1	92
	Cathode	7	0.8	0.8	0.8
	Grid	1	0	0	0
V5 12AU6 3rd I.F. Amp. (F.M.)	Plate	5	74	73	72
	Screen	6	74	73	72
	Cathode	7	0.3	0.3	0.4
	Grid	1	-0.2	-0.4	-0.2
V6 12AL5 F.M. Det.	Plate	2	—	—	—
	Cathode	5	—	—	—
	Plate	7	—	—	—
	Cathode	1	—	—	—
V7 12AV6 A.M. Det. Audio Amp.	Plate	7	58	57	57
	Grid	1	-0.8	-0.8	-0.8
	Plate	5	-0.5	-0.3	-0.3
	Grid (Diode)	2-5	—	—	—
V8 35C5 Audio Output	Plate	7	130	130	130
	Screen	6	96	94.5	94.5
	Cathode	1	5.1	5.0	5.0
	Grid	2-5	—	—	—

Rectifier output should be approximately 139 volts, 70 ma.

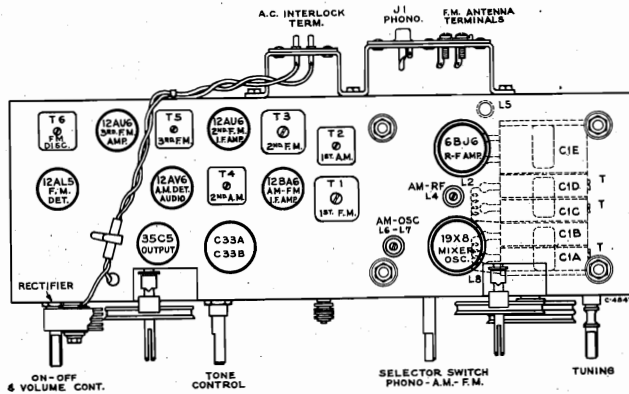

Tube and Trimmer Locations

AM Alignment

FUNCTION SWITCH IN AM POSITION

Steps	Connect high side of sig. gen. to—	Sig. gen. output	Turn radio dial to—	Adjust for peak output
1	Pin No. 1 of V3 in series with .01 mfd.	455 kc. (mod.)	Quiet point at high freq. end	T4 bottom core (sec.) T4 top core (pri.)
2	Tap lug 4 on AM RF coil			T2 bottom core (sec.) T2 top core (pri.)
3		1620 kc. (mod.)	1620 kc.	C1A-T (osc.)
4		1400 kc. (mod.)	1400 kc.	C37 (ant.) C1C-T (rf.)
5	Short wire placed near loop for radiated signal	600 kc. (mod.)	600 kc.	L6 (osc.) with 10,000 ohm resistor from C1C RF stator to gnd. (rocking gang)
6				L4 (RF) with the 10,000 ohms removed
7	Repeat steps 4, 5 and 6 until maximum gain is obtained			

FM Alignment

FUNCTION SWITCH IN FM POSITION—VOLUME CONTROL MINIMUM—TONE CONTROL CENTER

Steps	Connect high side of sig. gen. to—	Sig. gen. output	Turn radio dial to—	Adjust for max. output
1	Pin No. 1 of V5-12AU6	10.7 mc.	Quiet point at low frequency end	T6 top core for zero d.c. (across C26) T6 bottom core for maximum d.c. (junction of R24 and R25)
2	Pin No. 1 of V4-12AU6			+T5 top core
3	Pin No. 1 of V3-12BA6			T3 top core +T3 bottom core
4	C1D Stator			T1 top core +T1 bottom core
5		90 mc.	90 mc.	+FM osc. L8
6		106 mc.	106 mc.	+FM R.F. C1D-T
7	FM Ant. terminals thru 270 ohm resistor	90 mc.	90 mc.	+FM R.F. L2
8		Repeat steps 6 and 7 until maximum gain is obtained		
9		100 mc.	100 mc.	+FM Ant. coil L5

*If necessary for accurate peaking, the winding in the same transformer not being peaked should be loaded with a 680 ohm resistor.
†Connect VoltOhmyst to pin 1 of V5 through a 220K isolating resistor with 1/4 inch maximum exposed lead at grid terminal end. Output adjusted for 1 volt d.c. Dress VoltOhmyst lead away from input circuits.

Oscillator frequency is above signal frequency on both AM and FM

MODELS 2-XF-931
Series, Ch. RC1121A

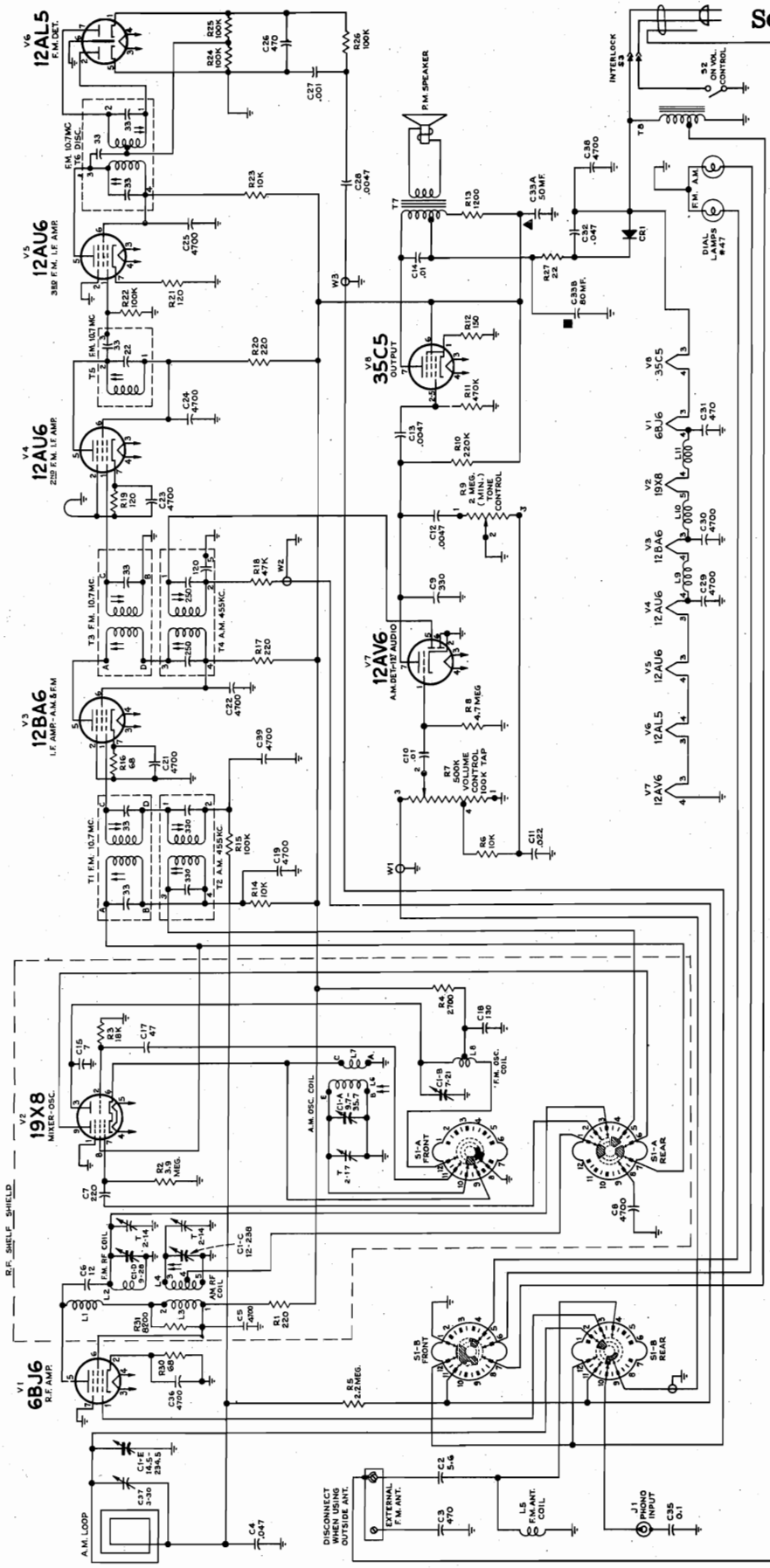

EE-49331

ALL RESISTANCE VALUES IN OHMS UNLESS OTHERWISE NOTED.
RESISTANCE VALUES IN KILOHMS UNLESS OTHERWISE NOTED.
RESISTANCE VALUES IN MEGOHMS UNLESS OTHERWISE NOTED.

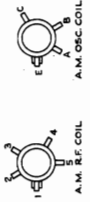

Simplified Schematic—"FM" Position

FRONT AND REAR SECTIONS OF FUNCTION SWITCH S1-A AND S1-B ARE VIEWED FROM FRONT WITH THE SWITCH SHAFT IN EXTREME COUNTER-CLOCKWISE POSITION #1 (PHONE) POSITION
POSITION
FUNCTION
PHONE
A.M.
F.M.

MODELS 2-XF-931
Series, Ch. RC1121A

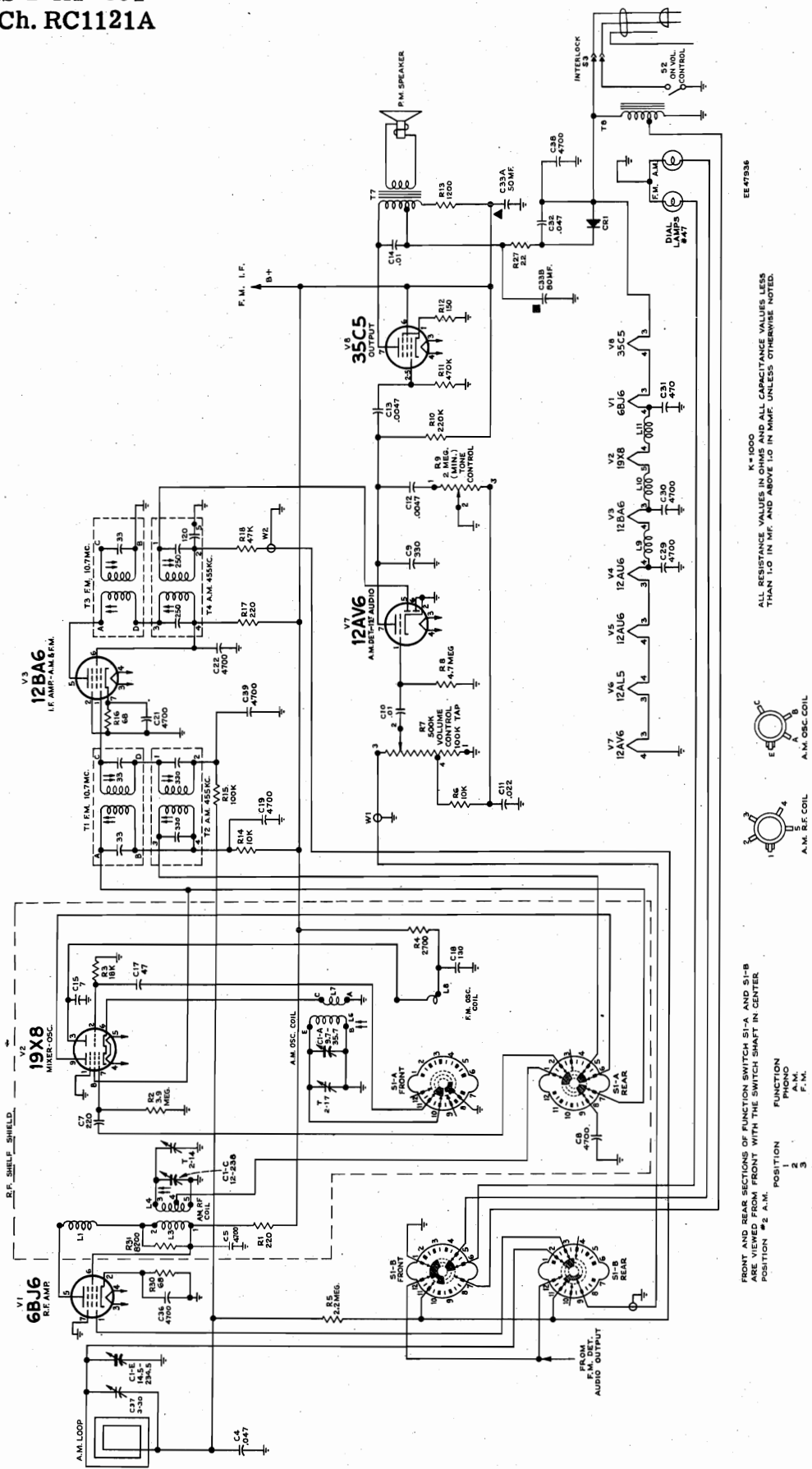

FRONT AND REAR SECTIONS OF FUNCTION SWITCH S1-A AND S1-B ARE VIEWED FROM FRONT WITH THE SWITCH SHAFT IN CENTER POSITION *E A.M. POSITION

1	PHONO
2	A.M.
3	F.M.

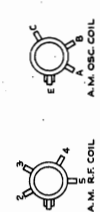

Simplified Schematic—"AM" Position

*1000
ALL RESISTANCE VALUES IN OHMS AND ALL CAPACITANCE VALUES LESS THAN 1.0 IN MF. AND ABOVE 1.0 IN MMF. UNLESS OTHERWISE NOTED.

EE47536

MODELS 2-XF-931
Series, Ch. RC1121A

CRITICAL LEAD DRESS

1. All FM IF Transformer grid and plate leads should be short and direct as possible and kept low, near chassis.
2. C26 leads should be kept as short as possible.
3. C32 leads should be kept as short as possible on T6 terminal 6 side.
4. T6 and R25 leads should be kept as short as possible on leads.
5. C27 should ground in hole near terminal 5 of V6 with short leads.
6. AM oscillator coil should not be tilted over toward function switch when wrapping short bus leads to switch.
7. Keep leads V5 pin 5, to T6 term 1, as short as possible and low near chassis.
8. Dress C28 down on chassis and against terminal board. Run filament lead between V5 and V6 on side of V6 socket opposite C28.
9. All ceramic button 4700 uuf condensers should have leads as short as possible.
10. Green lead from AM oscillator stator gang terminal to AM oscillator coil should be dressed against front of shield box and up above filament choke.
11. RF plate choke L1, should be dressed at least 1/8" away from AM RF coil L4 and at least 1/8" from shield.
12. Mixer grid condenser C7 should be dressed away from FM oscillator gang stator terminal and away from leads connecting to terminals 8 and 9 of V2 socket.
13. Filament chokes L10 and L11 should be raised a minimum of 1/16" above chassis.
14. Use varnished tubing only on choke and coupling cond.
15. Leads coming through shield partition slot.
16. Condenser C2 should have lead on antenna terminal end not more than 3/16" long to prevent possible contact of lead or body to "Hot" chassis.
17. Condensers C3 and C35 should use varnished tubing, not vinyl, to prevent breakthrough crossing chassis edge.
18. Oscillator grid condenser C17 should have short leads and be dressed away from filament choke L10.
19. Leads from loop terminal to chassis terminal board should have a minimum of three twists.

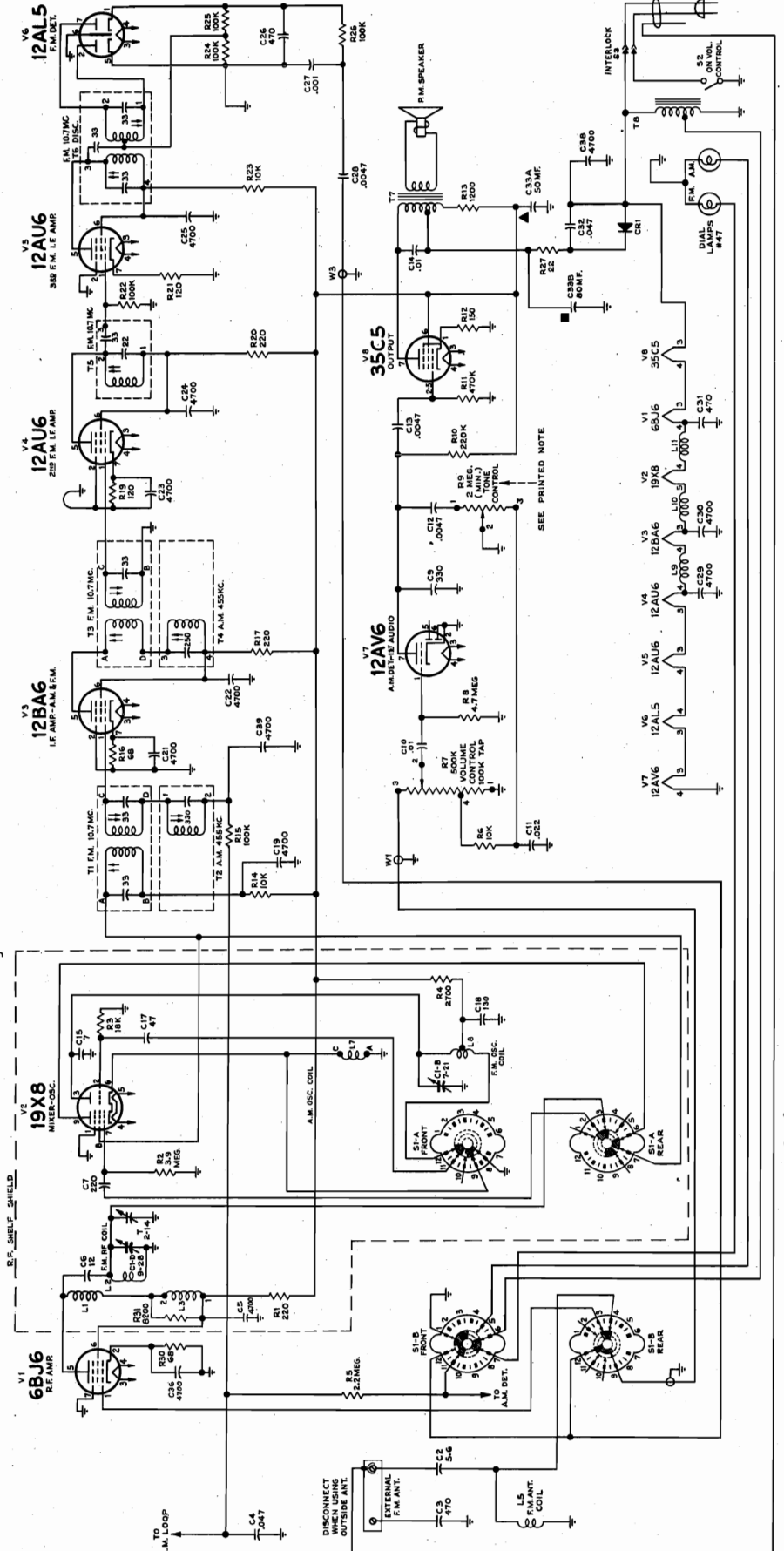

EE47937

K-1-000
ALL RESISTANCE VALUES IN OHMS AND ALL CAPACITANCE VALUES LESS THAN 1.0 IN MF. AND ABOVE 1.0 IN MMF. UNLESS OTHERWISE NOTED.

Acceptable value of R9 may be 2 to 50 megohms.



FRONT AND REAR SECTIONS OF FUNCTION SWITCH S1-A AND S1-B ARE VIEWED FROM FRONT WITH THE SWITCH SHAFT IN EXTREME COUNTER-CLOCKWISE POSITION #1 (PHONE) POSITION
1 PHONE
2 A.M.
3 F.M.

MODELS 2-XF-931 Series, Ch. RC1121A

STOCK No.	PART DESCRIPTION	STOCK No.	PART DESCRIPTION
	CHASSIS ASSEMBLIES RC-1121A		
77520	Bushing—Laminated bushing (3/8" long with shoulder) for station selector pointer pulley and shaft assembly.	77527	Shaft—Tuning knob shaft
77522	Capacitor—Variable tuning capacitor (C1A, C1B, C1C, C1D, C1E, C1A-T, C1C-T, C1D-T)	75192	Shield—Tube shield for V1
70997	Capacitor—Fixed, ceramic, non-insulated, 5.6 mmf., ±1 mmf., 500 volts D.C. Temp. coef. = 0 (C2)	76331	Shield—Tube shield for V2
77530	Capacitor—Fixed, ceramic, non-insulated, 7 mmf., ±.5 mmf., 500 volts D.C. Temp. coef. = 80 (C15)	77566	Socket—Dial lamp socket
33380	Capacitor—Fixed, ceramic, non-insulated, 12 mmf., ±5%, 500 volts D.C. Temp. coef. = 0 (C6)	77087	Socket—Tube socket, 7 pin, miniature, moulded, saddle mounted for V1
77531	Capacitor—Fixed, ceramic, non-insulated, 47 mmf., ±10%, 500 volts D.C. Temp. coef. = 0 (C17)	76336	Socket—Tube socket, 9 pin, miniature, moulded, saddle mounted for V2
77532	Capacitor—Fixed, ceramic, non-insulated, 130 mmf., ±2 1/2%, 500 volts D.C. Temp. coef. = -750 (C18)	73117	Socket—Tube socket, 7 pin, miniature, wafer for V3, V4, V5, V6, V7, V8
39636	Capacitor—Fixed, mica, 220 mmf., 500 volts D.C. (C7)	31970	Spring—Dial cord spring
75792	Capacitor—Fixed, ceramic, insulated, 330 mmf., ±20%, 500 volts D.C. High K (C9)	31418	Spring—Drive cord spring
76992	Capacitor—Fixed, mica, 470 mmf., 300 volts D.C. (C26, C31)	77524	Switch—Function switch (S1)
39644	Capacitor—Fixed, mica, 470 mmf., 500 volts D.C. (C3)	77666	Transformer—Filament transformer, 117 volt A.C. input
73473	Capacitor—Fixed, ceramic, 4700 mmf., +100%, -0%, 500 volts D.C. High K disc (C5, C8, C19, C21, C22, C23, C24, C25, C29, C30, C36, C38, C39)	77517	Transformer—Output transformer (T7)
73520	Capacitor—Electrolytic comprising 1 section of 80 mfd., 150 volts and 1 section of 50 mfd., 150 volts (C33A, C33B)	77511	Transformer—Ratio detector transformer—complete with adjustable cores (T6)
77533	Capacitor—Fixed, miniature, tubular, paper, .001 mfd., 200 volts D.C. (C27)	76335	Transformer—First I.F. transformer—A.M.—complete with adjustable cores (T2)
73920	Capacitor—Fixed, tubular, paper, .0047 mfd., 600 volts (C12, C13, C28)	77514	Transformer—First I.F. transformer—F.M.—complete with adjustable cores (T1)
73561	Capacitor—Fixed, tubular, paper, .01 mfd., 400 volts (C10)	76328	Transformer—Second I.F. transformer—A.M.—complete with adjustable cores (T4)
73594	Capacitor—Fixed, tubular, paper, .01 mfd., 600 volts (C14)	77513	Transformer—Second I.F. transformer—F.M.—complete with adjustable cores (T3)
73562	Capacitor—Fixed, tubular, paper, .022 mfd., 400 volts (C11)	77512	Transformer—Third I.F. transformer—F.M.—complete with adjustable cores (T5)
73558	Capacitor—Fixed, tubular, paper, .047 mfd., 200 volts (C4)	33726	Washer—"C" washer for station selector pointer pulley and shaft or tuning knob shaft
75071	Capacitor—Fixed, tubular, moulded, .047 mfd., 400 volts (C32)	34373	Washer—"C" washer to fasten idler pulleys
73551	Capacitor—Fixed, tubular, paper, 0.1 mfd., 400 volts (C35)		SPEAKER ASSEMBLIES 971933-1
73935	Clip—Mounting clip for I.F. transformers	77539	Speaker—5 1/4" P.M. speaker complete with cone and voice coil (3.2 ohms)
77538	Coil—Antenna coil—F.M. (L5)		MISCELLANEOUS
77534	Coil—Choke coil (L1)	77543	Antenna—Antenna loop and back cover complete with power cord (includes C37)
77535	Coil—Choke coil (L9, L10, L11)	77543	Back—Cabinet back complete with loop, capacitor and power cord (includes C37)
77526	Coil—Oscillator coil—A.M.—complete with adjustable core (L6, L7)	Y2468	Cabinet—Maroon plastic cabinet less "RCA Victor" emblem and function decal for Model 2-XF-931
77537	Coil—Oscillator coil—F.M. (L8)	Y2469	Cabinet—Ivory plastic cabinet less "RCA Victor" emblem and function decal for Model 2-XF-932
77525	Coil—RF coil—A.M.—complete with adjustable core (L3, L4)	Y2470	Cabinet—Green plastic cabinet less "RCA Victor" emblem and function decal for Model 2-XF-933
77536	Coil—RF coil—F.M. (L2)	Y2471	Cabinet—Red plastic cabinet less "RCA Victor" emblem and function decal for Model 2-XF-934
77528	Connector—Combination phono input connector and antenna terminal board (J1)	Y2472	Cabinet—Beige plastic cabinet less "RCA Victor" emblem and function decal for Model 2-XF-935
75474	Connector—Single contact male connector for speaker lead	77559	Cap—Station selector pointer cap—A.M.
77529	Connector—Two (2) contact male connector for power cord	77558	Cap—Station selector pointer cap—F.M.
77516	Control—Tone control (R9)	77544	Capacitor—Adjustable, mica trimmer, 3-30 mmf. (C37)
77515	Control—Volume control and power switch (R7, S2)	77545	Cord—Power cord and plugs
72953	250" Dial Cord Reel—Dial cord (approx. 49" overall required)	77542	Decal—Control function decal
77523	Drive cord (approx. 11" overall required)	77033	Emblem—"RCA Victor" emblem
16058	Drum—Variable tuning capacitor drive drum and hub	77560	Grille—Metal grille
31480	Grommet—Rubber grommet for mounting RF shelf (4 required)	77548	Knob—Function switch knob—maroon—for Model 2-XF-931
77521	Lamp—Dial lamp (Mazda 47)	77550	Knob—Function switch knob—ivory—for Model 2-XF-932
72602	Nut—Speednut for station selector pointer pulley and shaft bushing	77552	Knob—Function switch knob—green—for Model 2-XF-933
77510	Pulley—Idler pulley for indicator cord (2 required)	77556	Knob—Function switch knob—red—for Model 2-XF-934
77519	Pulley—Pulley and shaft (split) for station selector pointers	77554	Knob—Function control knob—beige—for Model 2-XF-935
77519	Rectifier—Selenium rectifier, 100 MA (CR1)	77547	Knob—Tuning control, tone control or volume control and power switch knob—maroon—for Model 2-XF-931
76346	Resistor—Wire wound, 1200 ohms, 4 watts (R13)	77549	Knob—Tuning control, tone control or volume control and power switch knob—ivory—for Model 2-XF-932
503022	Resistor—Fixed, composition: 22 ohms, ±10%, 1/2 watt (R27)	77551	Knob—Tuning control, tone control or volume control and power switch knob—green—for Model 2-XF-933
503068	68 ohms, ±10%, 1/2 watt (R16, R30)	77555	Knob—Tuning control, tone control or volume control and power switch knob—red—for Model 2-XF-934
503112	120 ohms, ±10%, 1/2 watt (R19, R21)	77553	Knob—Tuning control, tone control or volume control and power switch knob—beige—for Model 2-XF-935
503115	150 ohms, ±10%, 1/2 watt (R12)	73203	Nut—Speed nut to fasten "RCA Victor" emblem to cabinet
503122	220 ohms, ±10%, 1/2 watt (R1, R17, R20)	77563	Pad—Cork and rubber pad (1/32" x 3/16" x 3/16") for mounting metal grille to cabinet
503227	2700 ohms, ±10%, 1/2 watt (R4)	77557	Pointer—Station selector pointer
503282	8200 ohms, ±10%, 1/2 watt (R31)	73992	Retainer—Knob retainer (knob to cabinet)
503310	10,000 ohms, ±10%, 1/2 watt (R6, R14, R23)	76837	Spring—Retaining spring for knobs (knob to shaft)
503318	18,000 ohms, ±10%, 1/2 watt (R3)	77561	Window—Polystyrene window for L.H. side of cabinet
503347	47,000 ohms, ±10%, 1/2 watt (R18)	77562	Window—Polystyrene window for R.H. side of cabinet
502410	100,000 ohms, ±5%, 1/2 watt (R24, R25)		
503410	100,000 ohms, ±10%, 1/2 watt (R15, R22, R26)		
503422	220,000 ohms, ±10%, 1/2 watt (R10)		
503447	470,000 ohms, ±10%, 1/2 watt (R11)		
503522	2.2 megohm, ±10%, 1/2 watt (R5)		
503539	3.9 megohm, ±10%, 1/2 watt (R2)		
503547	4.7 megohm, ±10%, 1/2 watt (R8)		

APPLY TO YOUR RCA DISTRIBUTOR FOR PRICES OF REPLACEMENT PARTS

MODEL 2-S-10,
Ch. RC1111



Specifications

Tuning Range

Standard Broadcast (AM).....	540-1600 kc.
Frequency Modulation (FM).....	88-108 mc.
Intermediate Frequency (AM).....	455 kc.
Intermediate Frequency (FM).....	10.7 mc.

Tube Complement

Tube Used	Function
Radio Chassis RC1111	
(1) RCA 6CB6.....	R-F Amplifier
(2) RCA 6J6.....	Mixer and Oscillator
(3) RCA 6BA6.....	I-F Amplifier
(4) RCA 6AU6.....	F-M Driver
(5) RCA 6AL5.....	Ratio Detector
(6) RCA 6AV6.....	AM Det.-AVC-A-F Amplifier

Audio Chassis RS141

(1) RCA 6C4.....	Phase Inverter
(2) RCA 6V6GT.....	Audio Output
(3) RCA 6V6GT.....	Audio Output
(4) RCA 5Y3GT.....	Rectifier

Lamps

Dial (2).....	#51, 6-8 volts, 0.2 amp.
Jewel (1).....	#51, 6-8 volts, 0.2 amp.

Power Supply Rating..... 115 volts, 60 cycles, 100 watts

Audio Power Output Rating

Radio.....	undistorted 8 watts, maximum 9 watts
Phonograph.....	undistorted 10 watts, maximum 12 watts

Loudspeaker (92569-12W)

Size and Type.....	12 inch P.M.
Voice Coil Impedance.....	3.2 ohms at 400 cycles

Tuning Drive Ratio..... 9:1 (4½ turns of knob)

Net Weight..... 96 lbs.

Dimensions (overall)

Height... 35½ in. Width... 35 in. Depth... 23 in.

Record Changer (930409-5, or -10)

Turntable Speed.....	33⅓, 45 or 78 r.p.m.
Record Capacity.....	Up to fourteen 7 inch RCA type or twelve 10 inch or ten 12 inch or ten 10 inch and 12 inch intermixed
Pickup (Stock No. 75475).....	Crystal with replaceable styli

General Description

This instrument is a Victrola combination having nine tubes, plus one rectifier. It has a modern style cabinet in either walnut, mahogany, or limed oak finish. The entire receiver (with the exception of the power supply and speaker) is built as a unit with the automatic record changer for "pull-out" operation. The three speed record changer is nested over the radio chassis on a plastic case. Record storage space is provided for both large and small diameter records.

For standard broadcast reception, a loop antenna is mounted on the roll-out unit back. A folded dipole is mounted inside the cabinet for use on the FM band. Provision is made for connecting an external antenna for either the broadcast or FM bands.

By rotating the function switch, the 2S10 can be operated as:

1. Phonograph sound channel for the three speed record changer.

2. Standard broadcast "A" band receiver (540-1600 kc).
3. Broadcast "FM" band receiver (88-108 mc).

The function switch controls the internal connections for:

- A. RF-IF stage AVC voltages from AM or FM detector.
- B. Audio amplifier input from any one of three channels.
- C. B+ voltage application to RF-IF circuits.
- D. Audio output tube bias voltage. In phonograph operation, R2 is disconnected from R107, increasing available power output for phonograph operation.
- E. Selection of tuned circuits for AM or FM operation.

A horizontal tilted slide rule type dial is located along the top front face of the plastic roll-out case. The dial is edge-lighted at both ends by dial lamps. An amber jewel lamp, visible at the bottom front, glows whenever the set is in operation.

MODEL 2-S-10, Ch. RC1111 Record Changer

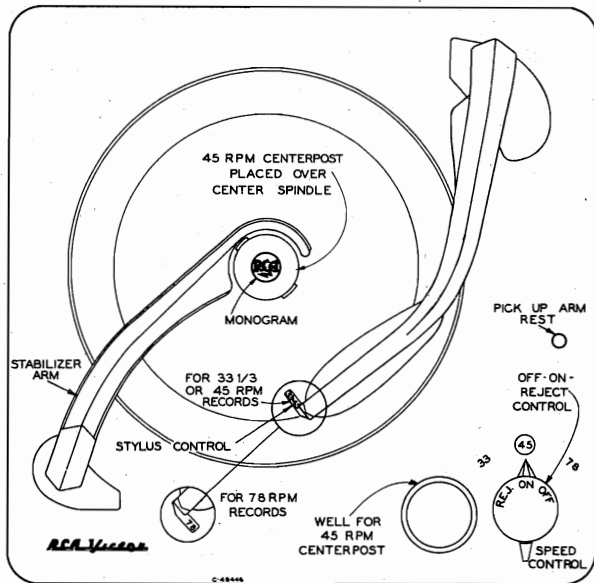

Controls

Record Changer Controls

The record changer has a dual control on the motorboard and a stylus selector control on the pickup arm. The inner control (circular knob) is the OFF-ON-REJECT control. Turning this knob to the center position energizes the motor and starts the turntable, when turned to the right (clockwise) it starts the mechanism into complete automatic operation. The mechanism will shut off automatically after the last record has been played but can be shut off manually by turning this knob to the left (counter-clockwise).

The outer control (double ended lever) is the speed control. It has three normal positions, "33", "45", "78" to select the turntable speed desired and a neutral position (midway between "45" and "78"). The control should be turned to this neutral position if the changer is not expected to be in use for an extended period of time.

The stylus control has two normal positions (right and left) and one shipping position (lever pointing up). When playing 33 1/3 or 45 r.p.m. records the lever is turned so that "33-45" is visible on the TOP of the lever; likewise for 78 r.p.m. records "78" should be visible on the TOP.

The removable centerpost is for use with 45 r.p.m. records

having the large centerhole. It must be placed over the center spindle with the "RCA" trademark monogram FACING to the FRONT. When not in use it is placed in a well at the front of the motorboard.

To load or remove records, the record stabilizer is lifted and turned off-side. After loading it is turned to the center where it rests on top of the stack of records.

Record Changer Adjustments

Landing Adjustment

Only one landing adjustment is necessary. The landing position of the stylus is adjusted by means of the eccentric stud (20A), mounted on the pickup arm support bracket. When adjusted for correct landing on one side of record, the landing position for other sizes of records is automatically corrected.

Pickup Arm Height Adjustment

The pickup arm height during cycle is adjusted by means of the hex head screw (17), located in the pickup arm.

Turn control knob to "REJ" and rotate turntable by hand until arm has risen to its maximum height. Adjust screw so that stylus is 1 3/8" above turntable.

Stylus Force Adjustment

Stylus force should be 7 1/2 to 9 1/2 grams. Loosen screw (14), and move slide until the correct force is obtained.

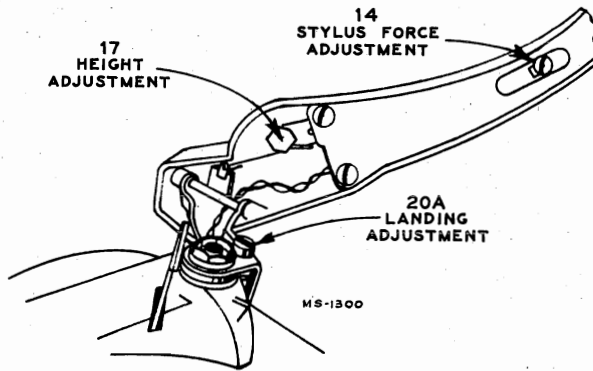

Adjustments

Tripping

The tripping method used in this mechanism is a velocity method. Velocity tripping is effective between 4 3/4" and 3 1/4" diameters, when the stylus moves inward 1/8" or more per revolution of the turntable. No adjustment is required.

Radio

Operating Instructions

RADIO—Turn extreme right hand FUNCTION knob to "AM" or "FM" radio position as desired. Turn OFF-VOLUME Knob "ON" and advance to mid-position for medium volume. Allow approximately 20 seconds for tube warm-up. With TUNING knob, select desired station indicated by dial pointer. Set tone controls for most pleasing reception. Turn BASS control counter-clockwise and TREBLE control clockwise for full tone. Adjust volume level as desired.

PHONOGRAPH—Turn extreme right hand FUNCTION knob to "PH" position. Turn OFF-VOLUME knob "ON" and advance to mid-position for medium volume. Set tone controls as indicated above for best tone. Refer to RECORD CHANGER section for operational information.



Radio Controls

Roll-Out Mechanism

Record Changer Mounting

The record-changer is mounted in a roll-out carriage. The changer mechanism is mounted on springs and should be free floating.

Roll-out Carriage Removal

Roll-out carriage has two stop pins, (one at the back end of each slide) held in place by retaining spring. To remove roll-out carriage, it is first necessary to pull the retaining springs out of the slides with a pair of long nose pliers, the stop pins are then easily removed. The roll-out carriage may then be removed from the front of the cabinet after disconnecting its connecting cables.

Roll-out Carriage Travel

The roll-out carriage has a normal movement limitation of approximately 10 inches. If it does not have this amount of movement, it may be due to an obstruction or from slippage or creeping of the balls of the slide mechanism. Travel restriction due to slippage or creeping of balls in the slide mechanism can be corrected by exerting slightly greater pull until the normal travel limitation is reached. The carriage should then operate to its full travel with normal pull.

Tube Socket Voltages

Tube Type and Function	Tube Element	Pin No.	AM	FM	Phono
V1 6CB6 R.F. Amp.	Plate	5	215	180	—
	Screen	6	74	62	—
	Cathode Grid	2	0.4	0.4	—
V2 6J6 Osc. and Mixer	Plate	2	55	58	—
	Grid	5	-1.2	-1.3	—
	Grid	6	43	46	—
V3 6BA6 I.F. Amp.	Plate	5	210	210	—
	Screen	6	126	115	—
	Cathode Grid	7	0.9	0.7	—
V4 6AU6 Driver	Plate	5	216	216	—
	Screen	6	150	150	—
	Cathode Grid	7	1.5	1.5	—
V5 6AL5 Ratio Det.	—	—	—	—	—
	—	—	—	—	—
	—	—	—	—	—
V6 6AV6 Audio Amp.	Plate	7	88	88	104
	Grid	1	-0.7	-0.7	-0.8
V7 6C4 Phase Inverter	Plate	5	87.5	88	120
	Cathode	7	-11	-11	-13
	Grid	6	-16	-16	-19
V8 6V6GT V9 6V6GT Audio Power Output	Plate	3	300	300	298
	Screen	4	224	224	252
	Cathode Grid	8	0	0	0
V10 5Y3GT Rectifier	—	5	-17	-17	-21
	Fil.	8	305	305	307

Voltages measured with VoltOhmyst and should hold within $\pm 20\%$ with rated line voltage. Tuning condenser closed—no signal input.

Critical Lead Dress

1. The 1st F.M. I.F. plate lead should be dressed away from the R.F. plate.
2. Dress the 1st A.M. I.F. plate lead to S-2 wafer away from the A.M. R.F. coil.
3. The ground strap between the R.F. Shelf and the main chassis should be well soldered and kept as short as practicable but yet allow some flexibility for the R.F. Shelf.
4. Dress A.C. power switch wires away from all audio components.
5. Dress C-26 down toward base between terminal board and side apron.
6. C-18 bypass should ground as close to the R.F. Shelf ground strap as practicable.
7. Dress C-25 away from arm of volume control.
8. All leads, from the R.F. shelf, leaving through the shields must be kept as short as possible so as to minimize F.M. oscillator radiation.
9. Dress A.C. leads in the RS141 chassis away from audio input leads and components.
10. Dress all leads away from R1 in the RS141 chassis.
11. All leads for F.M. should be kept short especially on the R.F. shelf.

FM Alignment

FUNCTION SWITCH IN FM POSITION—VOLUME CONTROL MAXIMUM

Steps	Connect high side of sig. gen. to—	Sig. gen. output	Turn radio dial to—	Adjust for max. output
1	Connect the d-c probe of a VoltOhmyst to the negative lead of the 2 mfd. capacitor C39 and the common lead to chassis. Adjust sig. gen. output to provide approx. -4 v. Indication during alignment.			
2	Pin #1 of 6AU6 (V4) in series with .01 mf.	10.7 mc AM modulated		Top of driver trans. T5 for max. d-c voltage †Bottom of driver trans. T5 for min. audio output
3	Repeat steps 2 and 3			
4	Thru 470 ohms to C1-F. Connect grid end of cable close to V2 cathode ground on r-f shelf	10.7 mc	88 mc	*Top (sec.) & bottom (pri.) cores of T3 *Top (sec.) & bottom (pri.) cores of T1
5	To FM antenna terminals thru 120 ohms in each side of line	90 mc	90 mc	L8 (osc.)
6	Repeat steps 6, 7 and 8			
7	Connect a sweep generator to the antenna terminals thru 120 ohms in each side of line. Connect an oscilloscope to junction of R33 and C35 to check response and linearity of FM band. Peak to peak separation should not be less than 180 kc.	106 mc	106 mc	C1-F trimmer (ant.) and C1-C trimmer (r. f.)
8	Repeat steps 6, 7 and 8	90 mc	90 mc	L1 (ant.) and L2 (r. f.)
9	Two or more points may be found which lower the audio output. At the correct point the minimum audio output is approached rapidly and is much lower than at any incorrect point.			
10	*Use a 680 ohm resistor to load the plate winding while the grid winding of the same trans. is being peaked. Then the grid winding is loaded with the 680 ohm resistor while the plate winding is being peaked. When windings are loaded, it is necessary to increase the 10.7 mc input to maintain the -4 volts indication. L8, L1 and L2 are adjustable by increasing or decreasing the spacing between turns. Oscillator signal tracks above signal frequency. The proper adjustment of the I.F. cores can be determined by starting the core all the way out. The first peak obtained is the correct one.			

Alignment Procedure

CORRECT ALIGNMENT OF THE AM R.F. STAGES REQUIRES THAT THE FM R.F. STAGES BE ALIGNED FIRST

Alignment Indicators:

An RCA VoltOhmyst or equivalent meter is necessary for measuring developed d-c voltage during FM alignment. Connections are specified in the alignment tabulation. An output meter is also necessary to indicate minimum audio output during FM Ratio Detector alignment. Connect the output meter across the speaker voice coil.
The RCA VoltOhmyst can also be used as an AM alignment indicator, either to measure audio output or to measure a-v-c voltage.
When audio output is being measured the volume control should be turned to maximum. Adjust tone controls for maximum highs and lows during alignment.

Signal Generator:

For all alignment operations connect the low side of the signal generator to the receiver chassis. The output should be adjusted to provide accurate resonance indication at all times. If output measurement is used for AM alignment the output of the signal generator should be kept as low as possible to avoid a-v-c action.

AM Alignment

RANGE SWITCH IN AM POSITION

Steps	Connect high side of sig. gen. to—	Sig. gen. output	Turn radio dial to—	Adjust for peak output
1	Pin No. 1 of V3 in series with .01 mid.	455 kc. (mod.)	Quiet point at low freq. end	T4 bottom† core (sec.), T4 top core (pri.), T2 top† core (sec.), T2 bottom core (pri.)
2	To stator of C1-F			
PERFORM FM ALIGNMENT BEFORE PROCEEDING				
3	Short wire placed near loop for radiated signal	1620 kc. (mod.)	1620 kc.	C1B-T (osc.)
4		1400 kc. (mod.)	1400 kc.	C1D-T (ant.), C1E-T (r.f.)
5		600 kc. (mod.)	600 kc.	L5 (osc.) with 10,000 ohm resistor from RF stator to gnd. (rocking gang)
6				L7 (RF) with the 10,000 ohms removed.
7	Repeat steps 4, 5 and 6 until no improvement in sensitivity is obtained.			

Oscillator frequency is above signal frequency on both AM and FM.
ⓐ ⓑ ⓓ encircled letters indicate recommended alignment sequence.

MODEL 2-S-10,
Ch. RC1111

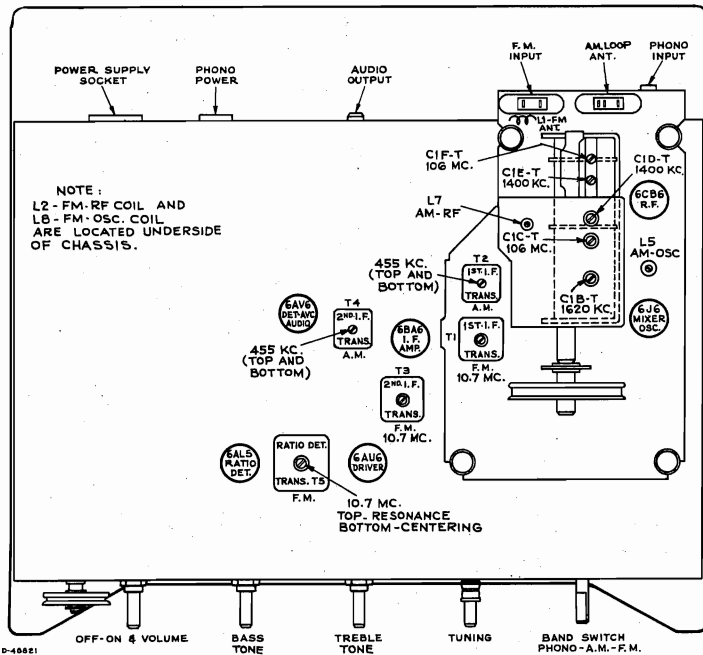

RC1111 Chassis—Tube and Trimmer Locations

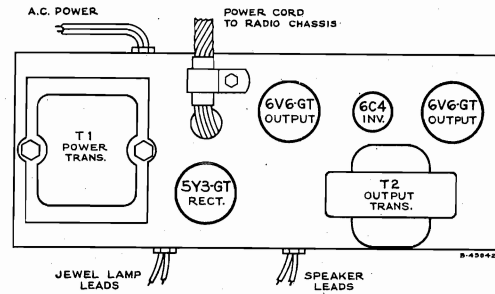

RS141—Audio Amplifier Chassis

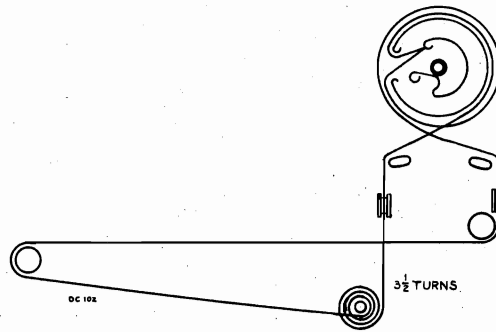

Dial Cord Drive

STOCK NO.	PART DESCRIPTION	STOCK NO.	PART DESCRIPTION
	CHASSIS ASSEMBLIES RC 1111	77315	Coil—Oscillator coil—FM (L8)
77308	Capacitor—Variable tuning capacitor (C1-A, C1-B, C1-C, C1-D, C1-E, C1-F)	77305	Coil—R.F. coil—AM—complete with adjustable core (L6, L7)
75613	Capacitor—Ceramic, 5 mmf. (C12, C41)	77314	Coil—R.F. coil—FM (L2)
77352	Capacitor—Ceramic, 6.8 mmf. (C16)	75543	Connector—2 contact female connector for phono power cable (P1)
39044	Capacitor—Ceramic, 15 mmf. (C14)	74879	Connector—2 contact female connector for antenna leads
76348	Capacitor—Ceramic, 47 mmf. (C10)	75062	Connector—9 contact male connector for power input (I1)
75612	Capacitor—Ceramic, 68 mmf. (C15, C17)	35787	Connector—Single contact female connector for audio cable (I2)
39396	Capacitor—Ceramic, 100 mmf. (C5)	33742	Connector—Single contact female connector for phono cable (I3)
75614	Capacitor—Ceramic, 150 mmf. (C13, C28, C31)	75562	Control—Tone control—H.F. (R29)
75611	Capacitor—Ceramic, 220 mmf. (C3)	75561	Control—Tone control—L.H. (R16)
39640	Capacitor—Mica, 330 mmf. (C36, C37)	75537	Control—Volume control and power switch (R19, S2)
39644	Capacitor—Mica, 470 mmf. (C6)	72953	Cord—250' Drive Cord Reel (approx. 57" overall req'd)
73473	Capacitor—Ceramic, 4700 mmf. (C2, C4, C7, C9, C11, C18, C20, C23, C24, C27, C32, C34, C35, C40)	75564	Coupling—Spring coupling for function switch extension shaft
73747	Capacitor—Electrolytic 2 mfd., 50 volts (C39)	74839	Fastener—Push fastener to fasten RF shelf (4 req'd)
77468	Capacitor—Tubular, paper, .0018 mfd., 600 volts (C8)	16058	Grommet—Rubber grommet for mounting RF shelf (4 req'd)
73795	Capacitor—Tubular, paper, .0038 mfd., 600 volts (C25)	75548	Grommet—Rubber grommet for mounting slides (4 req'd)
73920	Capacitor—Tubular, paper, .0047 mfd., 600 volts (C30)	11765	Lamp—Dial lamp—Mazda 51
72490	Capacitor—Tubular, paper, .005 mfd., 200 volts (C33, C38)	77311	Latch—Bottom cover latch
73561	Capacitor—Tubular, paper, .01 mfd., 400 volts (C29)	77486	Nut—Speed nut for latch adjustment screw
73797	Capacitor—Tubular, paper, .015 mfd., 600 volts (C22)	76421	Pin—Slide mechanism stop pin
77469	Capacitor—Tubular, paper, .018 mfd., 200 volts (C21)	72602	Pulley—Drive cord pulley
73562	Capacitor—Tubular, paper, .022 mfd., 400 volts (C26)	35641	Pulley—Drive cord pulley—1 3/8" dia.
73558	Capacitor—Tubular, paper, .047 mfd., 200 volts (C19)		Resistor—Fixed, composition:—
73935	Clip—Mounting clip for I.F. transformer for 75558 & 76328	503039	39 ohms, ±10%, 1/2 watt (R3)
77313	Coil—Antenna coil—FM (L1)	503068	68 ohms, ±10%, 1/2 watt (R21)
71942	Coil—Filament choke coil (L9, L10)	503110	100 ohms, ±10%, 1/2 watt (R14, R34)
75569	Coil—Oscillator coil—AM—complete with adjustable core (L3, L4, L5)	503112	120 ohms, ±10%, 1/2 watt (R30)
		503139	390 ohms, ±10%, 1/2 watt (R12)
		503168	680 ohms, ±10%, 1/2 watt (R6, R25, R32)
		503210	1000 ohms, ±10%, 1/2 watt (R2)
		502212	1200 ohms, ±5%, 1/2 watt (R36)
		502233	3300 ohms, ±5%, 1/2 watt (R35)

Parts (Continued)

MODEL 2-S-10,
Ch. RC1111

STOCK NO.	PART DESCRIPTION	STOCK NO.	PART DESCRIPTION
503282	8200 ohms, ±10%, 1/2 watt (R5)	73690	Cord—Power cord and plug
503315	15,000 ohms, ±10%, 1/2 watt (R33)	74838	Grommet—Power cord strain relief (1 set)
503318	18,000 ohms, ±10%, 1/2 watt (R13, R17)	72776	Pin—Contact pin for speaker lead (2 req'd)
503322	22,000 ohms, ±10%, 1/2 watt (R22, R31)	73637	Resistor—Wire wound, 2200 ohms, 5 watts (R101)
503327	27,000 ohms, ±10%, 1/2 watt (R9, R18)		Resistor—Fixed, composition:—
503339	39,000 ohms, ±10%, 1/2 watt (R37)	503110	100 ohms, ±10%, 1/2 watt (R108)
503356	56,000 ohms, ±10%, 1/2 watt (R26)	522127	270 ohms, ±5%, 2 watts (R107)
503412	120,000 ohms, ±10%, 1/2 watt (R11, R15)	502233	3300 ohms, ±5%, 1/2 watt (R102)
503415	150,000 ohms, ±10%, 1/2 watt (R4, R24)	503368	68,000 ohms, ±10%, 1/2 watt (R105)
503422	220,000 ohms, ±10%, 1/2 watt (R23)	503382	82,000 ohms, ±10%, 1/2 watt (R103)
503427	270,000 ohms, ±10%, 1/2 watt (R28)	503447	470,000 ohms, ±10%, 1/2 watt (R104, R106)
503447	470,000 ohms, ±10%, 1/2 watt (R38)	31364	Socket—Pilot lamp socket
503510	1 megohm, ±10%, 1/2 watt (R39)	31251	Socket—Tube socket, octal, wafer
503515	1.5 megohm, ±10%, 1/2 watt (R10)	73117	Socket—Tube socket, 7 pin, miniature, wafer
503522	2.2 megohm, ±10%, 1/2 watt (R1, R7, R8)	77323	Transformer—Output transformer (T102)
503610	10 megohm, ±10%, 1/2 watt (R20)	75566	Transformer—Power transformer, 117 volt, 60 cycle (T101)
504622	22 megohm, ±20%, 1/2 watt (R27)		
77303	Shaft—Extension shaft for function switch		
75540	Shaft—Tuning knob shaft		
73584	Shield—Tube shield for V1, V6		
75192	Shield—Tube shield for V2		
77310	Slide—Slide mechanism (2 req'd)		
31364	Socket—Dial lamp socket		
74179	Socket—Tube socket, 7 contact, miniature, wafer for V1, V3, V4, V5		
73117	Socket—Tube socket, 7 contact, miniature, wafer for V6		
77306	Socket—Tube socket, 7 pin, moulded, saddle-mounted for V2		
77312	Spring—Actuating spring for bottom cover latch		
76332	Spring—Drive cord spring		
75563	Spring—Retaining spring for function switch extension shaft		
76422	Spring—Retaining spring for slide mechanism stop pin		
77304	Support—Polystyrene support for FM oscillator coil complete with mounting bracket		
77307	Switch—Function switch (S1)		
75559	Transformer—1st. I.F. transformer—FM—complete with adjustable cores (T1)		
75558	Transformer—1st. I.F. transformer—AM—complete with adjustable cores (T2)		
76328	Transformer—2nd. I.F. transformer—AM—complete with adjustable cores (T4)		
75560	Transformer—2nd. I.F. transformer—FM—complete with adjustable cores (T3)		
73743	Transformer—Ratio detector transformer complete with adjustable core (T5)		
33726	Washer—"C" washer for tuning knob shaft or drive cord pulley		
	ROLLOUT MECHANISM ASSEMBLIES		
77319	Bracket—Dial lamp socket bracket—L.H.		
77318	Bracket—Dial lamp socket bracket—R.H.		
77320	Dial—Polystyrene dial scale		
77321	Escutcheon—Dial scale escutcheon less dial		
77317	Frame—Plastic mounting frame—light brown—for chassis and record changer for blonde mahogany instruments		
77316	Frame—Plastic mounting frame—maroon—for chassis and record changer for mahogany or walnut instruments		
77322	Pointer—Station selector pointer		
	AMPLIFIER ASSEMBLIES		
	RS 141		
77324	Capacitor—Electrolytic comprising 1 section of 30 mfd., 450 volts, 1 section of 30 mfd., 350 volts and 1 section of 40 mfd., 25 volts (C101A, C101B, C101C)		
75643	Capacitor—Tubular, paper, oil impregnated, .001 mfd., 1000 volts (C103, C104)		
73789	Capacitor—Tubular, paper, .0068 mfd., 400 volts (C105)		
73562	Capacitor—Tubular, paper, .022 mfd., 400 volts (C102)		
72583	Cable—Shielded audio cable complete with pin plug (Includes P102)		
75064	Connector—9 contact female connector for power input cable (P101)		
			SPEAKER ASSEMBLIES
			92569-12W
			RMA—274
		75682	Cone—Cone and voice coil (3.2 ohms)
		76093	Speaker—12" P.M. speaker complete with cone and voice coil (3.2 ohms)
			NOTE: If stamping on speaker in instruments does not agree with above speaker number, order replacement parts by referring to model number of instrument, number stamped on speaker and full description of part required.
			MISCELLANEOUS
		77332	Antenna—Antenna loop—less cable
		74649	Antenna—F.M. antenna
		77327	Back—Back—light brown—for chassis and changer rollout assembly for blonde mahogany instruments
		77326	Back—Back—maroon—for chassis and changer rollout assembly for mahogany or walnut instruments
		77325	Back—Cabinet back
		75707	Board—Antenna terminal board
		71599	Bracket—Pilot lamp bracket
		72437	Cable—Shielded pickup cable complete with pin plug
		13103	Cap—Pilot lamp cap (Jewel)
		71892	Catch—Bullet catch and strike for cabinet doors
		X3222	Cloth—Grille cloth for blonde mahogany instruments
		X3130	Cloth—Grille cloth for mahogany or walnut instruments
		30870	Connector—2 contact male connector for record changer power cable
		74882	Connector—2 contact male connector for antenna loop cable
		74752	Connector—2 contact male connector for antenna lead
		71984	Decal—"RCA Victor" decal
		74273	Decal—"Victrola" decal
		37396	Grommet—Rubber grommet for speaker mounting
		74308	Hinge—Cabinet door hinge (1 set)
		77330	Knob—Function switch knob—maroon
		77331	Knob—Function switch knob—tan
		77328	Knob—Tuning control, tone control or volume control and power switch knob—maroon
		77329	Knob—Tuning control, tone control or volume control and power switch knob—tan
		11765	Lamp—Pilot lamp—Mazda 51
		73634	Nut—Speed nut for speaker mounting screws
		77335	Plate—Back plate for lower door pull (2 req'd)
		77334	Pull—Cabinet door pull—lower (2 req'd)
		77333	Pull—Cabinet door pull—upper—(4 req'd)
		75623	Screw—#8-32 x 3/8" trimit head screw for upper door pull
		74113	Screw—#8-32 x 1" trimit head screw for lower door pull
		74734	Spring—Spring clip for knobs
		75902	Spring—Suspension spring for main cable
		72936	Stop—Cabinet door stop

APPLY TO YOUR RCA DISTRIBUTOR FOR PRICES OF REPLACEMENT PARTS

MODEL 2-S-10,
Ch. RC1111

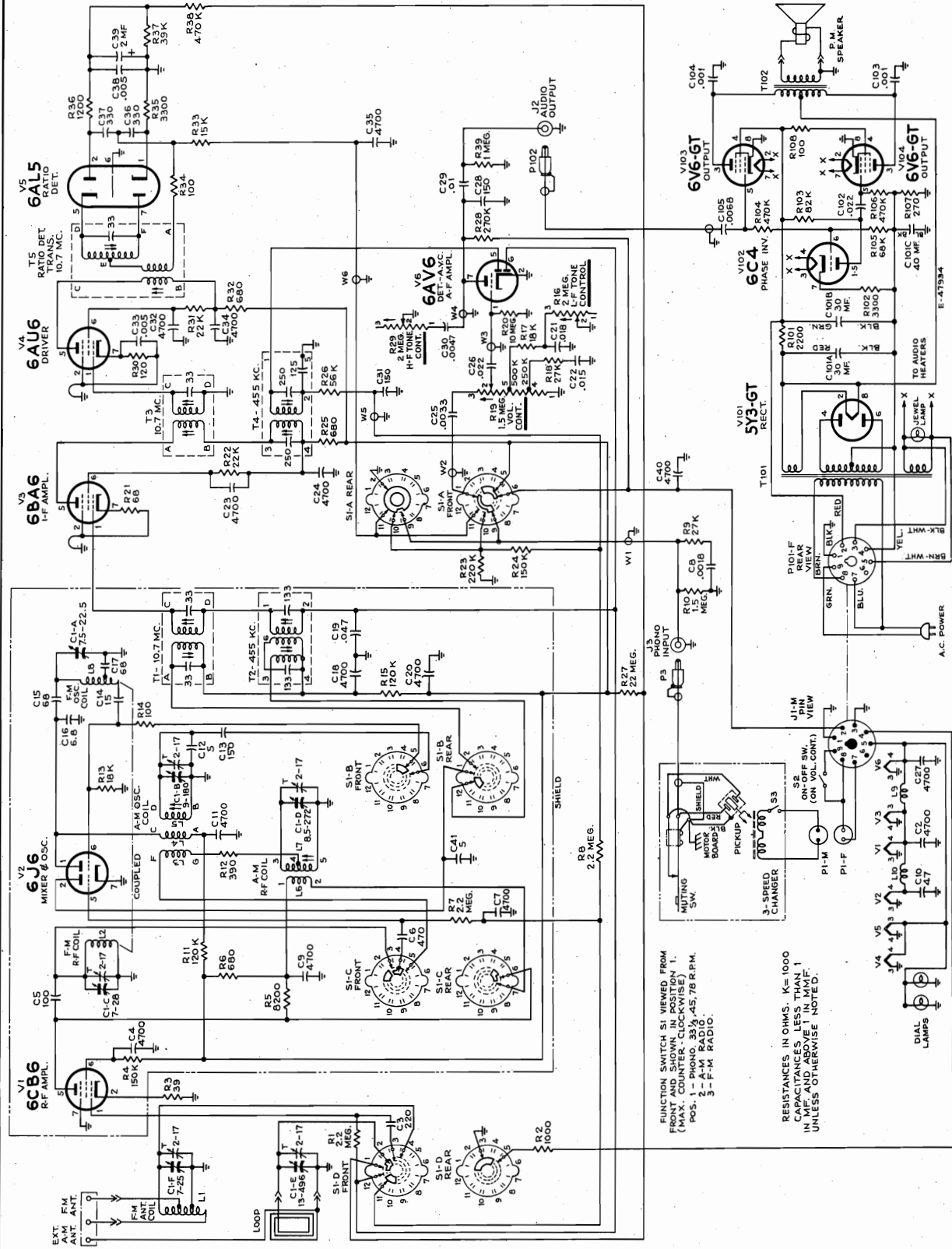

FUNCTION SWITCH S1 VIEWED FROM FRONT AND SHOWN IN POSITION 1. (MAX. COUNTER - CLOCKWISE) POS. 1 - PHONO, 2 - 45-78 R.P.M. 3 - F.M. RADIO.

RESISTANCES IN OHMS. K=1000 IN MF AND ABOVE 1 IN MMF. UNLESS OTHERWISE NOTED.

Complete Schematic Diagram—Chassis RC1111 and RS141

Cathode Currents (Ma.)

Tube	Term.	Phono	A.M.	F.M.
V1 6CB6	2	—	6	6
V2 6J6	7	—	3	3
V3 6BA6	7	—	13.7	13.5
V4 6AU6	7	—	10.3	10.6
V5 6AL5	1 & 5	—	—	—
V6 6AV6	2	0.7	0.5	0.5
V7 6C4	7	2.2	1.7	17.1
V8 6V6GT	8	35.5	20.6	21.1
V9 6V6GT	8	35.5	20.6	21.1
V10 5Y3GT	2	74	76	77.5

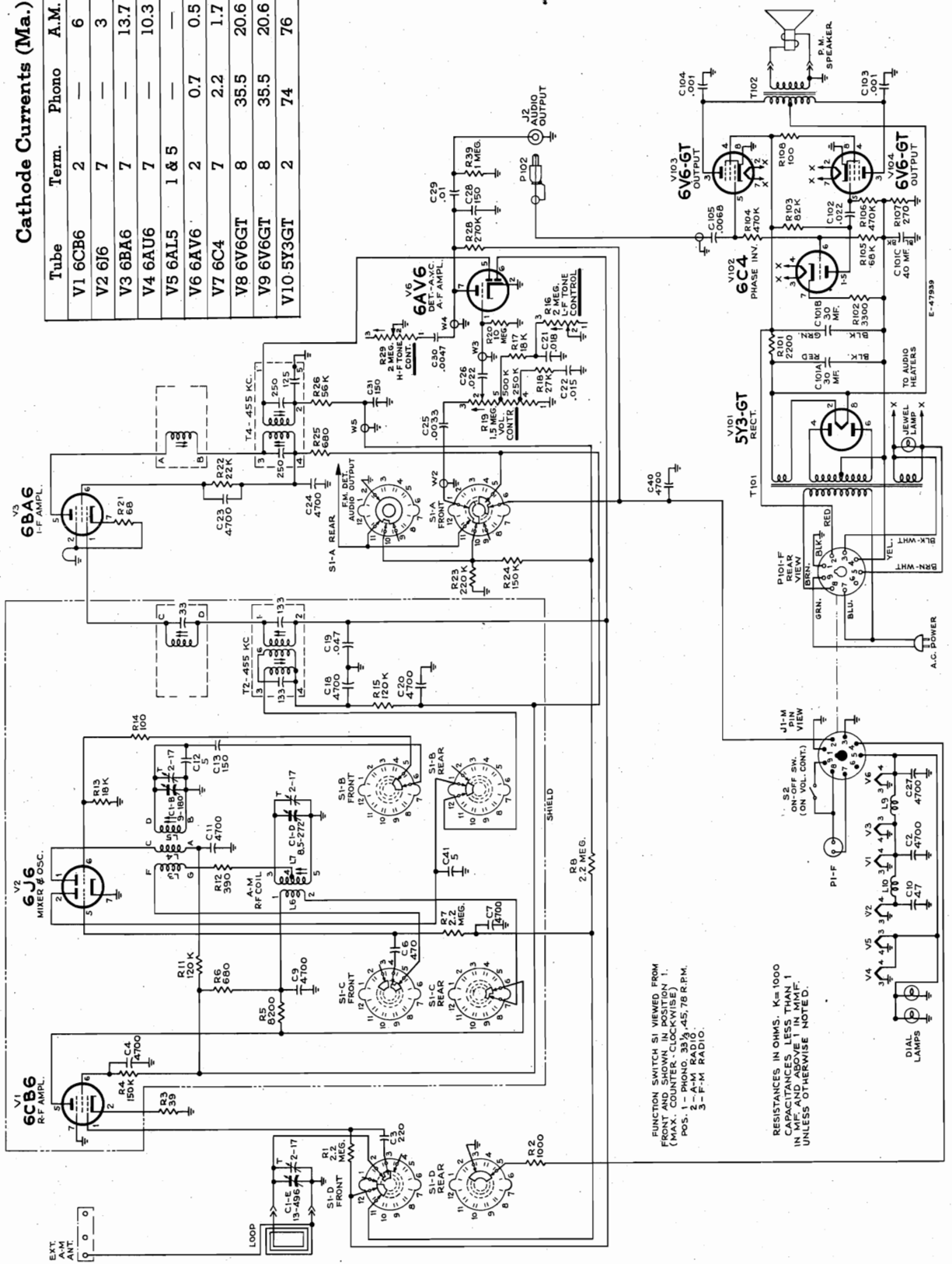

FUNCTION SWITCH S1 VIEWED FROM FRONT AND SHOWN IN POSITION 1. (M.F. POSITION IS SHOWN IN POSITION 1.) POS. 1 - PHONO. 3 1/2 - 45,78 R.P.M. 3 - F.M. RADIO.

RESISTANCES IN OHMS. K=1000 CAPACITANCES IN MICRO FARADS UNLESS OTHERWISE NOTED.

Simplified Schematic Diagram - "AM" Position

MODEL 2-S-10,
Ch. RC1111

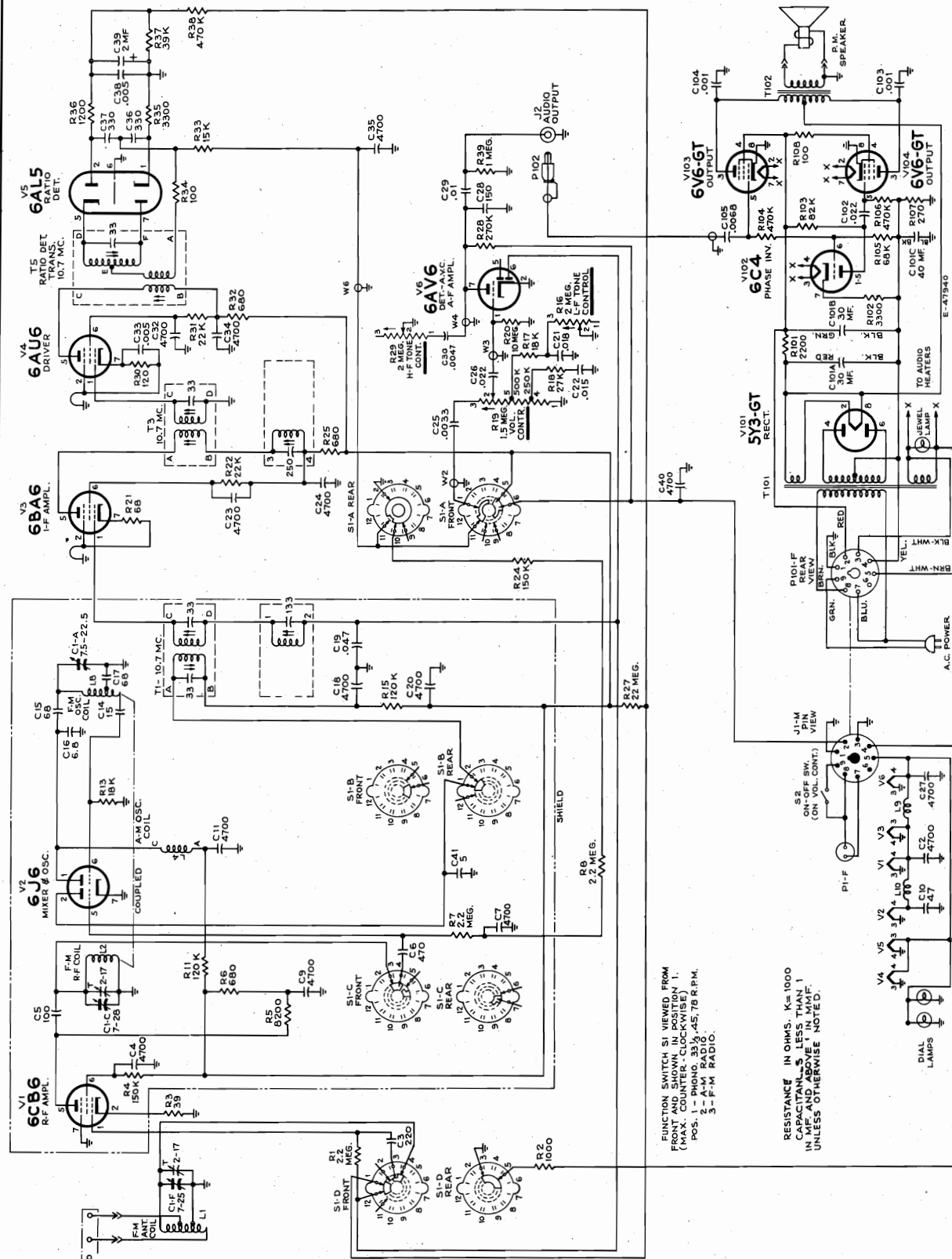

Simplified Schematic Diagram—"FM" Position

FUNCTION SWITCH S1 VIEWED FROM FRONT (MAX. COUNTER-CLOCKWISE) POS. 1 - PHONO, 33 1/3, 45, 78 R.P.M. 2 - A-M RADIO, 45, 78 R.P.M. 3 - P-M RADIO.

RESISTANCE IN OHMS, K=1000 CAPACITANCE IN MICROFARADS LESS THAN 1 IN MF AND ABOVE 1 IN MUF, UNLESS OTHERWISE NOTED.

ELECTRICAL SPECIFICATIONS

TUBE COMPLEMENT: 11 tubes plus rectifier—6CB6 RF amp., 12AT7 mixer, 12AT7 osc. and AFC., (2) 6CB6 IF amp., (2) 6AU6 limiters, 6AL5 FM det., 6AV6 AM det. and audio amp., 12AX7 audio amp., 12AX7 phono pre-amp., 6X5GT rectifier.

CONTROLS: Bass, Off-On-Volume, FM-AM-PH-TV selector, Tuning, Treble.

ANTENNA: FM-300 ohm or 72 ohm input. AM-high or low impedance transformer input. Low-noise loop also provided for AM and FM.

SENSITIVITY: FM-5 microvolts for 30 db. quieting. AM-5 microvolts for 0.5 volts output at either detector or audio amplifier.

FM DRIFT: Negligible with Automatic Frequency Control. Without AFC, ± 20 kc. after 10 sec. warmup.

OUTPUT: Capability up to 2 volts at less than 1/2% distortion from cathode follower. For use with either high or low gain amplifiers with input impedance of 10,000 ohms or higher. Cathode follower connection direct from detector also provided.

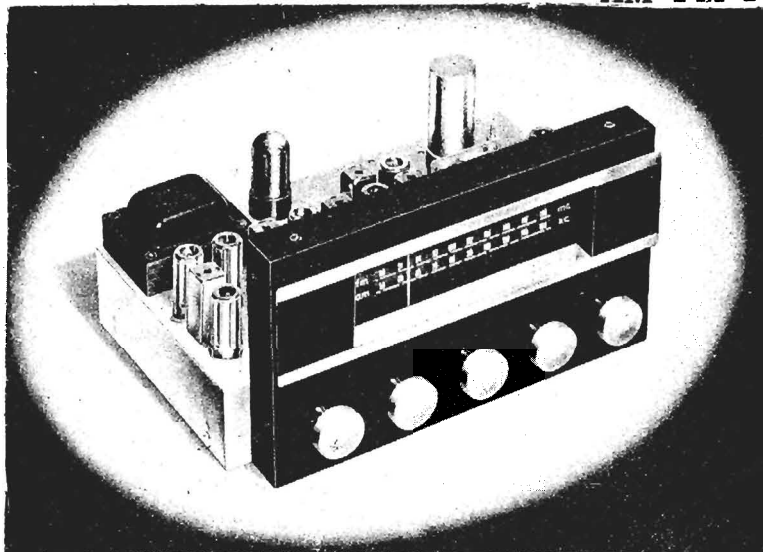

AM INTERSTATION WHISTLE FILTER: 25 db. rejection at 10 kc., 1 db. at 7 kc.

POWER CONSUMPTION: 105-125 volts, 60 cps., 50 watts.

SHIPPING WEIGHT: 16 lbs.

DIMENSIONS: 13 1/2" x 9 1/2" x 7" high.

BANDWIDTH: FM—190 kc.; AM—8.5 kc.

TONE COMPENSATION: Bass variable up to 16 db. boost or 14 db. cut at 60 cps. Treble variable up to 15 db. boost or 15 db. cut at 10,000 cps.

PHONO PRE-AMPLIFIER: 31 db. gain plus 22 db. bass compensation.

INTERMEDIATE FREQUENCIES: FM—10.7 mc.; AM—455 kc.

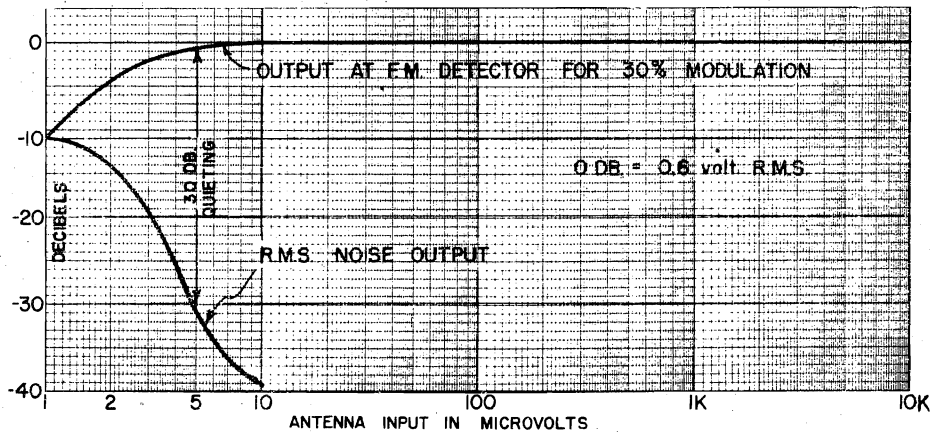

Fig. 1. FM Limiting Characteristic

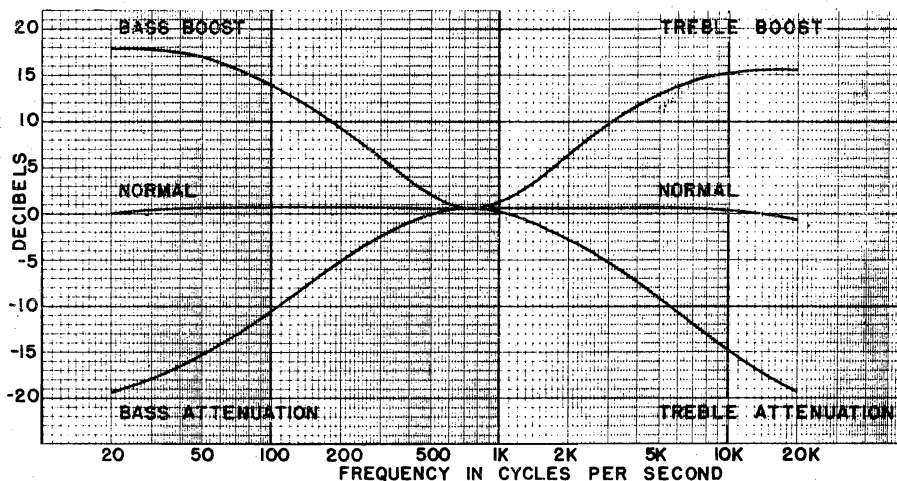

Fig. 2. Audio Characteristic

MODEL 10,
AM-FM Tuner

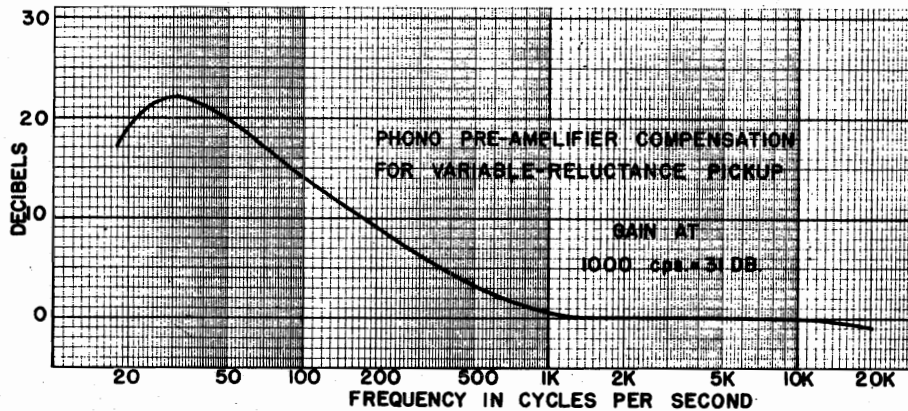

Fig. 3. Phono Pre-amplifier Characteristic

UNPACKING

These instructions cover the operation and installation of the Craftsmen 10 FM-AM Tuner. The entire manual should be read before installing the unit, since much general information is included that will be of value in making any custom-built installation.

As soon as the tuner has been unpacked, examine it for any apparent damage which might have occurred in shipment. Should any sign of damage be found, file a claim immediately with the carrier stating the extent of the damage.

Included with the C10 tuner chassis should be the following:

- 1 3B023 Brass escutcheon
- 1 7X403 AM low-impedance antenna
- 1 7A604A Shielded audio cable

GENERAL - Considerable thought should be given in respect to the installation of the chassis in order to obtain maximum benefit from the operating ease the chassis offers. The dial and controls should be positioned for easy access and reading which, in many cases, can be improved with a sloping front panel. If the mounting board cannot be readily tilted, wooden spacers can be inserted under the front mounting holes to provide the necessary inclination. Position the knobs sufficiently above any front projection to provide ample finger clearance for adjusting the knobs.

The types and orientation of the tubes used in the tuner permit satisfactory operation regardless of mounting position.

Other considerations in layout are accessibility to the rear for interconnections, sufficient clearance from any metal for the AM loop to insure good pickup, and ample air space above the tubes to prevent any deterioration to a finished wooden cabinet top from tube heat. Where the spacing is necessarily close, this effect may be alleviated with a thin sheet of bright metal tacked beneath the vulnerable surface.

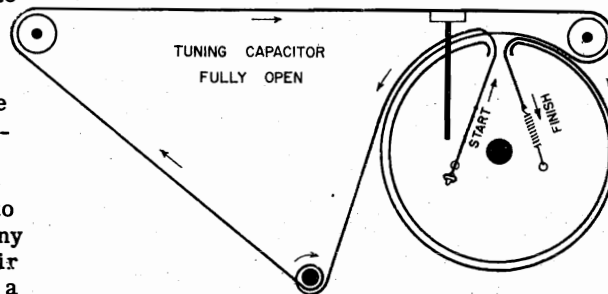
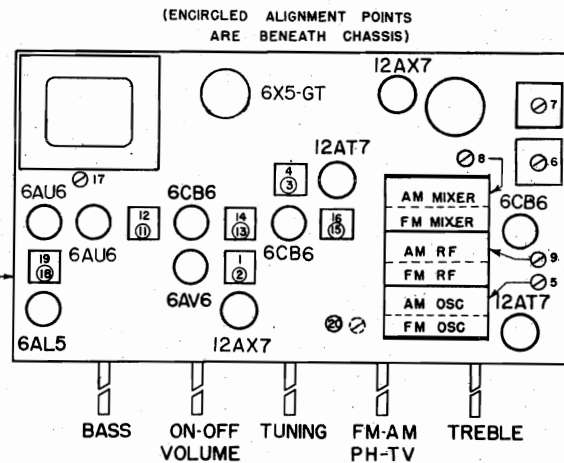

Dial Cord Drive.

MODEL 10, AM-FM Tuner

ALIGNMENT PROCEDURE — To set pointer, completely mesh tuning capacitor and align pointer with last reference mark at low frequency end of dial. Volume control should be in maximum clockwise position. Output of signal generator should be no

higher than necessary to obtain an output reading. Low side of signal generator and indicating meter should be connected directly to chassis at all times. Use an insulated screwdriver with 1/8" thick blade for adjusting IF transformers.

TUBE	FUNCTION	PIN 1	PIN 2	PIN 3	PIN 4	PIN 5	PIN 6	PIN 7	PIN 8	PIN 9
6CB6	RF AMP.	0	2.4	0	6.3*	145	145	2.4	--	--
12AT7	MIXER	154	0	2.1	0	0	-0.9	-0.9	0	6.3*
12AT7	OSC-AFC	150	1.8	0	0	0	182	-0.7	1.8	6.3*
6CB6	1st IF	-0.3	1.7	6.3*	0	150	150	0	--	--
6CB6	2nd IF	0	2.1	6.3*	0	150	150	0	--	--
6AU6	1st LIMITER	-0.3	0	6.3*	0	39	39	0	--	--
6AU6	2nd LIMITER	-0.8	0	6.3*	0	48	48	0	--	--
6AL5	FM DET.	0	-5.8	6.3*	0	-0.8	0	-4	--	--
6AV6	AM DET. & AUDIO AMP.	0	0.9	57	57	0.6	-0.6	106	--	--
12AX7	CATHODE-FOLLOWER	200	19	35	57	57	200	19	35	57
12AX7	PHONO PRE-AMP	81	0	1	57	57	59	0	0.9	57
6X5-GT	RECTIFIER	--	58	196*	--	196*	--	58	228	--

*AC Voltages measured at 1,000 ohms per volt.
DC Voltages measured with vacuum-tube voltmeter.

Socket connections are shown as bottom views.
Measurements are with no signal applied and bandswitch in FM position.

Measured values are from socket pin to common negative.
Line voltage maintained at 115 volts for voltage readings.

	SIGNAL GENERATOR			Dial Setting	Indicating Meter	Adjust	Indication
	Coupling	Freq.	Modulation				
1	.01 µf to pin 7 of 12AT7	455 kc	400 cps AM	Point of no interference	AC voltmeter at Audio output	1, 2, 3, & 4	Maximum deflection
2	220 µpf to AM ant. input	1500 kc	400 cps AM	1500 kc	Same as above	5	Maximum deflection
3	Same as above	600 kc	400 cps AM	Tune for maximum response	Same as above	6 & 7	Maximum deflection
4	Same as above	1400 kc	400 cps AM	Tune for maximum response	Same as above	8 & 9	Maximum deflection
5	Repeat Steps 3 & 4						
6	Same as above	1400 kc	10 kc AM	Tune for maximum response	Same as above	10	Null
7	.01 µf to pin 2 of 12AT7	10.7 mc	None	Point of no interference	Neg. DC VTVM across R31	11, 12, 13, 14, 15, & 16	Maximum deflection
8	Same as above	10.7 mc	None	Same as above	Neg. DC VTVM at junction R62 & R63	17 & 18	Maximum deflection
9	Same as above	10.7 mc	None	Same as above	Zero center scale DC VTVM at Det. Output	19	Zero volts between positive & negative reading
10	270 µ Carbon to FM ant. input	106 mc	400 cps FM + 25 kc	106 mc	AC voltmeter at Audio output	20	Maximum deflection
11	Same as above	90 mc	Same as above	Tune for maximum response	Same as above	Contract or extend coil spring L2, L4	Maximum deflection
12	Same as above	98 mc	400 cps FM + 250 kc	98 mc	Vertical input oscilloscope at Det. Output		Check symmetry of "S" shape

AM Alignment

FM Alignment

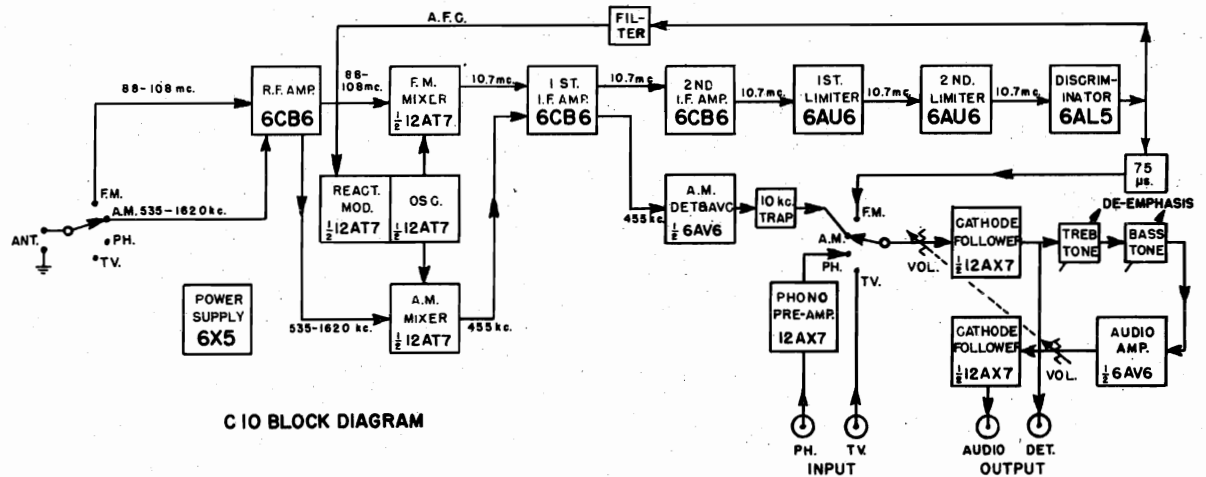

C 10 BLOCK DIAGRAM

MODEL 10, AM-FM Tuner

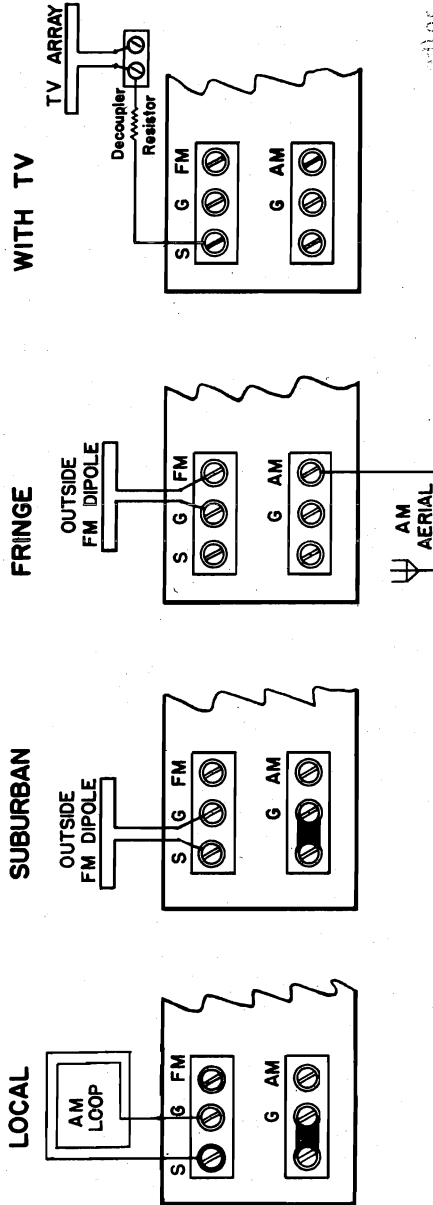

Fig. 6. Antenna Arrangements

For reception in local or urban localities, loop the flexible ribbon lead (furnished) around the cabinet interior and connect to terminals marked "S" and "G". Finally connect the shorting link between the blank terminal and "G". This ribbon lead forms a low-noise, low-impedance AM loop antenna and should be formed into the largest one or two turn loop practical in the available cabinet space. This loop also provides FM reception since terminal "S" is internally switched to the FM input.

Installations remote from stations might require outside antennas of a more elaborate nature. Connect exterior FM antennas to terminals "FM" and "G", or if to be used as an AM aerial as well, then connect to "S" and "G". Long-line AM aerials can be connected directly to the

high-impedance input "AM" (link disconnected) or if brought down through a low-impedance line, to "AM" with the link in place. Finally for installations including television, it is usually convenient to use the TV antenna to feed the FM and AM signals as well. This can be done by coupling lightly (through a 1000-ohm resistor) from terminal "S" to one side of the TV antenna terminals.

TELEVISION - Complete suggested interconnections for installations including television are shown in Figure 7. In general, it is desirable not to operate a television unit while attempting either FM or AM reception because of the various types of interference that may be encountered.

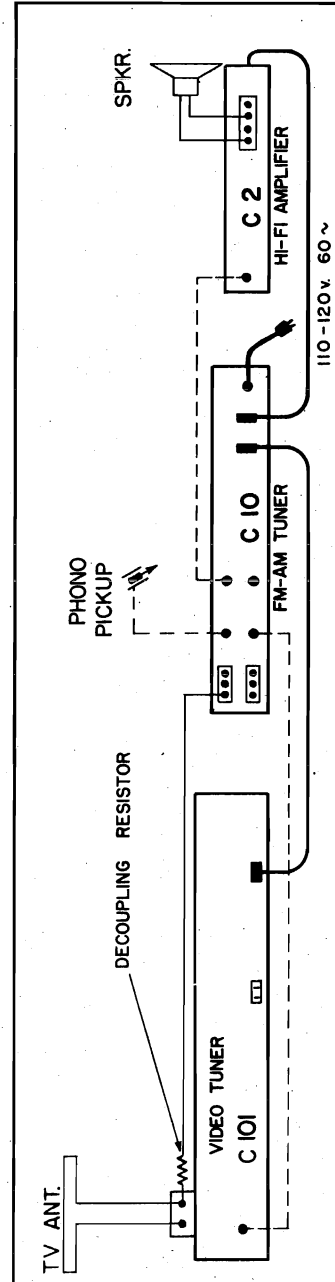
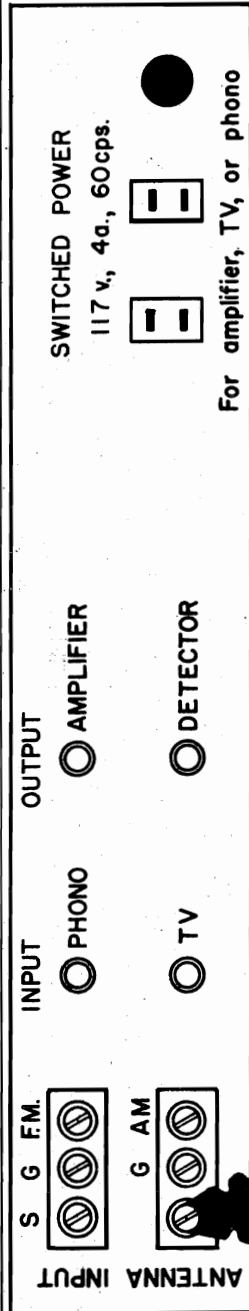

Fig. 7. Typical Installation Interconnections

MODEL 10,
AM-FM Tuner



Jumper used with AM Loop

Fig. 5. Rear View

A cathode-follower connection directly following the FM and AM detectors is available at the receptacle labeled Detector Output. This output bypasses the entire C10 audio system including the bass and treble controls and is useful for feeding recording amplifiers which have preset tone compensation while using the Amplifier Output for monitoring purposes. An audio amplifier with self-contained controls might also be fed from the Detector Output.

From either the Audio Output or Detector Output cathode-follower, as much as 50 feet of shielded cable can be used for inter-connection without undue loss of high-

frequency response.

PHONO - The Phono Input jack feeds a pre-amplifier compensated (see Figure 3) for use with variable-reluctance type cartridges. The input resistors, R151 and R152, shunting this jack are recommended for use with a GE cartridge; recommendations for other cartridges and microphone usage are as follows.

For a crystal-type phonograph cartridge, either use the TV input or remove 12AX7 pre-amplifier, R151, R152 and C154. Add jumper from Phono Input jack to previous connection from C154.

PHONO PRE-AMPLIFIER ADAPTATIONS

Cartridge Type	Input Resistance	Wiring
GE	13.5KΩ	Use as found.
Pickering	27KΩ	Remove one 27KΩ resistor.
Audak	54KΩ	Cut top of one 27KΩ, cut bottom of other 27KΩ, twist & solder free resistor pigtaills.
Microphone	1MΩ	Add jumper across 3300μf capacitor, C153. Replace two 27KΩ input resistors with 1MΩ.

ANTENNA ARRANGEMENTS

ANTENNA - Several antenna arrangements are possible for use with the C10 as shown in Figure 6 and the best arrangements will depend on the particular installation. The various antenna arrangements make use of AM

inputs at either high-impedance (shorting link removed) or low-impedance (shorting link in place), a single-ended FM input and an input marked "S" connected internally through a switch to either the FM or AM input.

MODEL 10,
AM-FM Tuner

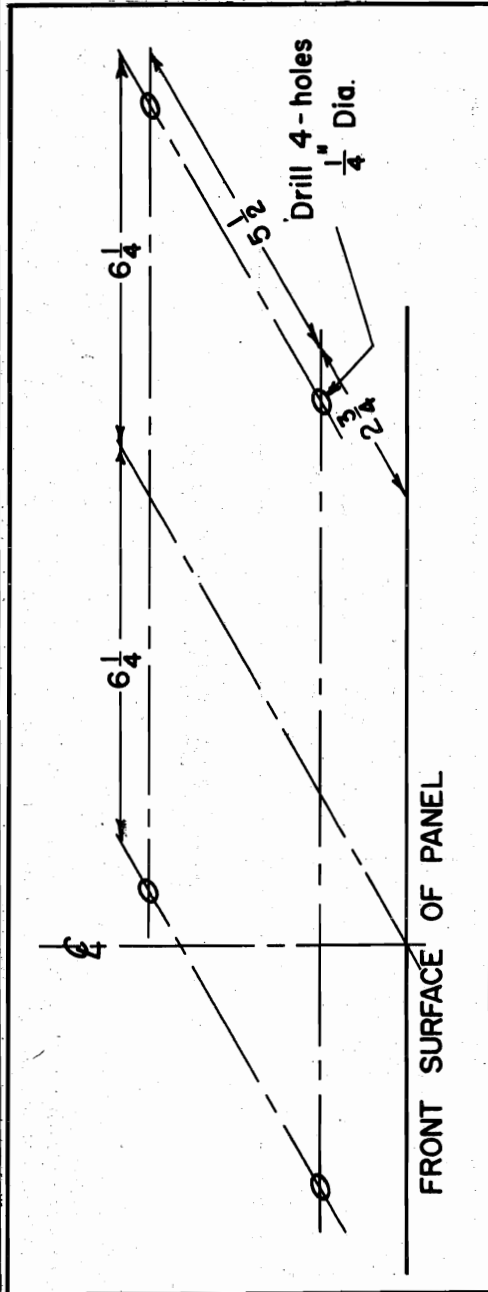

Fig. 4. Mounting Hole Layout

VENTILATION - Considerable ventilation must be provided to carry off the heat dissipated by the receiver. A "chimney effect" can be utilized advantageously in wall or bookcase installations by providing ports near the bottom and top of the enclosure to effect a flow of air past the chassis.

ASSEMBLY - The front panel cutouts should be made first by using the full-scale template provided. Note that this template is laid out symmetrically about the center knob and above the bottom mounting surface of the rubber shock mounts. Locate and drill the mounting holes

as shown in Figure 4. Insert the studs on the rear of the dial escutcheon into the two 3/16-in. diameter holes in the panel and secure the escutcheon with the two #6-32 nuts provided.

Remove the five press-fit knobs (use a steady outward pull on the knob) and the four mounting screws and washers found in the chassis mounts. Locate the chassis so that a 1/16-in. clearance exists between the inward flange of the escutcheon and the dial glass. Replace the four washers and screws and finally press the five knobs on their shafts, noting that the lettering uppermost on the channel knob indicates the channel selected for use.

ELECTRICAL CONNECTIONS

AUDIO SYSTEM - A cathode-follower Amplifier Output jack, furnishing up to 2 volts at less than 1/2% distortion from 20 to 20,000 cps., (refer to Figure 2) and the associated shielded audio cable have been provided to connect the C10 into new or existing audio systems. Any audio amplifier, such as the Craftsman 2 or 500 Amplifier,

with an input impedance of 10,000 ohms or greater can be operated from this output.

The audio amplifier power line cord should be plugged into the AC outlet on the rear of the chassis so that the amplifier can be turned on simultaneously with the FM-AM tuner.

MODEL 10,
AM-FM Tuner

PARTS LIST

Part No.	Ref. No.	Description	Part No.	Ref. No.	Description
CAPACITOR, Ganged Tuning			RESISTORS		
17S007	C1A	7-22 μ f, FM Osc. Tuning	RC20AE6R8K	R47	6.8 Ω , 1/2w, Carbon
	C1B	8-108 μ f, AM Osc. Tuning	RC20AE151K	R28, R39, R40	150 Ω , 1/2w, Carbon
	C1C	7-22 μ f, FM RF Tuning	RC20AE221K	R16, R24, R51	220 Ω , 1/2w, Carbon
	C1D	10-408 μ f, AM RF Tuning	RC20AE331K	R8, R50	330 Ω , 1/2w, Carbon
	C1E	7-22 μ f, FM Conv. Tuning	RC20AE152K	R110	1.5K Ω , 1/2w, Carbon
	C1F	10-408 μ f, AM Conv. Tuning	RC20AE102K	R6, R13, R21, R26, R44, R156	1000 Ω , 1/2w, Carbon
	C1b	2-15 μ f, AM Osc. Mica Trimmer	RC20AE222K	R9, R10, R153	2.2K Ω , 1/2w, Carbon
	C1d	2-15 μ f, AM RF Mica Trimmer	RC20AE472K	R33, R107	4.7K Ω , 1/2w, Carbon
	C1f	2-15 μ f, AM Conv. Mica Trimmer	RC20AE103K	R161	10K Ω , 1/2w, Carbon
CAPACITORS, Ceramic			RC20AE153K	R32	15K Ω , 1/2w, Carbon
17X402	C56	1-6 μ f, 500v, Trimmer	RC20AE223K	R104, R114	22K Ω , 1/2w, Carbon
CC20CK2R0D	C60	2 μ f, 500v, Tubular	RC20AE273K	R151, R152	27K Ω , 1/2w, Carbon
CC20SL100M	C54, C12	10 μ f, 500v, Tubular	RC20AE333K	R41, R48	33K Ω , 1/2w, Carbon
CC20SL150M	C55, C109, C113	15 μ f, 500v, Tubular	RC20AE473K	R105, R108	47K Ω , 1/2w, Carbon
CC20SL220M	C40	22 μ f, 500v, Tubular	RC20AE683K	R23, R25	68K Ω , 1/2w, Carbon
CC20CK220M	C39, C57, C59	22 μ f, 500v, NPO	RC20AE823K	R159	82K Ω , 1/2w, Carbon
CC20UK470M	C34, C58	47 μ f, 500v, Tubular	RC20AE104K	R4, R7, R17, R31, R42, R53, R62, R63, R157	100K Ω , 1/2w, Carbon
CC20SL101M	C18, C30, C61, C71	100 μ f, 500v, Tubular	RC20AE154K	R58, R77	150K Ω , 1/2w, Carbon
CC20SL221M	C8, C9, C11, C15, C43, C44, C62, C63, C65	220 μ f, 500v, Tubular	RC20AE224K	R5, R11, R22, R35, R111, R154	220K Ω , 1/2w, Carbon
CC25SL471K	C70	470 μ f, 500v, Tubular	RC20AE474K	R27, R102, R112	470K Ω , 1/2w, Carbon
CC20ZZ102X	C26, C33, C80, C114	1000 μ f, 500v, Tubular	RC20AE105K	R29, R57, R115, R155	1M Ω , 1/2w, Carbon
18X701	C17, C20, C81, C66, C28, C29, C32, C36, C41, C45, C46, C47, C48, C49, C50	5000 μ f, 500v, Disc	RC20AE225K	R18, R19, R30	2.2M Ω , 1/2w, Carbon
18X704	C7, C14, C102, C111, C23, C53	10,000 μ f, 500v, Disc	RC20AE335K	R158	3.3M Ω , 1/2w, Carbon
18X705	C38, C77	1500 μ f, 500v, Disc	RC20AE106K	R160	10M Ω , 1/2w, Carbon
CAPACITORS, Mica			RC30AE222K	R54	2.2K Ω , 1w, Carbon
17X205	C31	10-160 μ f, 300v, Trimmer	RC30AE103K	R52	10K Ω , 1w, Carbon
CM20A331K	C104	330 μ f, 500v, Molded	RC30AE223K	R34	22K Ω , 1w, Carbon
CAPACITORS, Paper			RC30AE473K	R49, R75	47K Ω , 1w, Carbon
CP10M4222K	C151	.0022 μ f, 400v, Tubular	RC40AE222K	R45	2.2K Ω , 2w, Carbon
CP10M4332K	C105, C153	.0033 μ f, 400v, Tubular	RW0471K	R103, R113	470 Ω , 1/2w, Wire Wound
CP10M4562K	C106	.0056 μ f, 400v, Tubular	RW2221K	R38	220 Ω , 2w, Wire Wound
CP10M4103M	C25, C154	.01 μ f, 400v, Tubular	RW5R47K	R43	0.47 Ω , 5w, Wire Wound
CP10M6103M	C52	.01 μ f, 600v, Tubular	RWX152K	R46	1.5K Ω , 10w, Wire Wound
CP10M4223M	C21, C6, C13	.022 μ f, 400v, Tubular	23S715	R106, R109	0.5M Ω , 1/4w, Carbon Potentiometer
CP10M4473M	C10, C27	.047 μ f, 400v, Tubular	23S727	R101	0.5M Ω , 1/4w, Carbon Potentiometer and Switch
CP10M4563K	C107	.056 μ f, 400v, Tubular	COILS & CHOKES		
CP10M4104M	C64, C101, C110	.1 μ f, 400v, Tubular	5A209	L4	FM Conv. Coil
CP10M2224M	C103, C112	0.22 μ f, 200v, Tubular	5A210	L2	FM RF Coil
CP10M4154M	C19	0.15 μ f, 400v, Tubular	5S402	L3, L5	3.3 μ h Choke
CAPACITORS, Electrolytic			5A017	L7	FM Limiter Coil
CE8H2501P	C155	10 μ f, 250v, Tubular	5X406	L9, L10, L11, L13	1.0 μ h Choke
CE8H0202P	C108, C152	25 μ f, 25v, Tubular	19S406	L6	1 h, 10 kc Filter
18S022	C51A	40 μ f, 300v, Twist Mount	SWITCHES		
	C51B	40 μ f, 300v, Twist Mount	4S006A	S1, S2, S3	4 Pos., 3 section Band Switch
	C51C	30 μ f, 300v, Twist Mount	TRANSFORMERS		
	C51D	20 μ f, 300v, Twist Mount	5X005	T10	10.7 mc FM Discriminator
PILOT LIGHTS			5X013	T5	10.7 mc FM Converter
15X003	P1, P2	No. 44 Pilot Light	5X014	T7, T9	10.7 mc FM IF
			5X015	T6	455 kc AM Converter
			5X016	T8	455 kc AM IF
			5A208	T3	FM Osc.
			5A218	T4	AM Osc.
			5A219	T2	AM RF
			5A220A	T1	AM Ant.
			19S208A	T11	Power Transformer

MODELS CR-41A, -42A,
-43A, Ch. 4D16-A

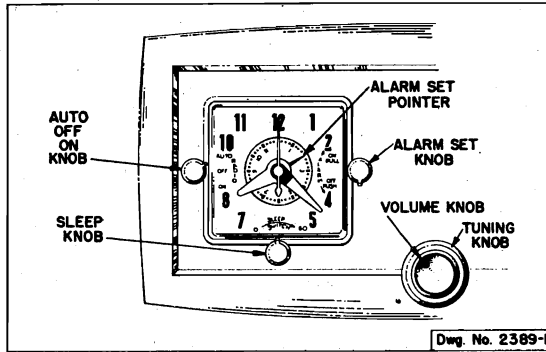

Front Cabinet View

SERVICE DATA

Power Supply..... 115 volts, 60 cycles AC only,
24 watts.
Frequency Range..... 540 to 1600 Kc.
Intermediate Freq..... 455 Kc.
Selectivity..... At 1000 Kc., 60 Kc. at 1000 x
signal.
Sensitivity..... 150 u. v. per meter.
Power Output..... 1.0 watts undistorted, 1.25 watts
maximum.
Loud Speaker..... 4" PM., v.c. impedance, 3.2 ohms.
Tube Complement.....
12BE6, Converter, 12AV6, or 12AT6,
12BA6, IF Amplifier Detector AVC Audio
50C5, Audio output

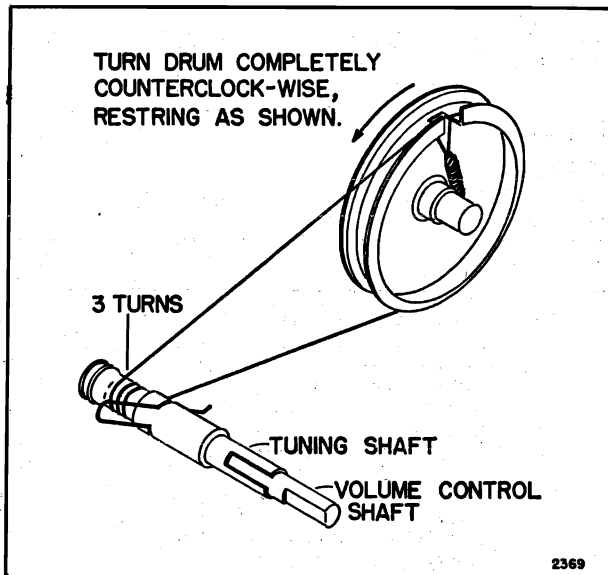

Dial Stringing Diagram

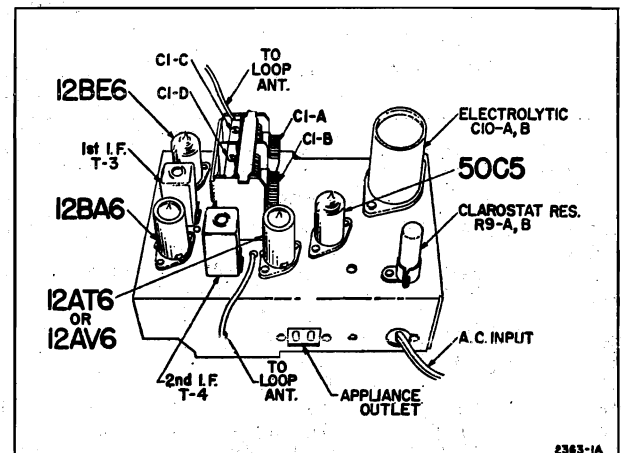

Chassis View

ALIGNMENT PROCEDURE

- Loop must be connected and volume set to maximum.

SIGNAL GENERATOR				TUNER SETTING	ADJUST FOR MAXIMUM OUTPUT
Frequency	Coupling Capacitor	Connection to Radio	Ground Connection		
455 kc.	.1 mf.	12BE6, Pin 7	HEAVY BUSS LEAD ACROSS CENTER OF CHASSIS	(Capacitor fully open) (plates out of mesh)	Top and bottom Cores in output and input I.F. cans
1620 kc.	.1 mf.	12BE6, Pin 7		(Capacitor fully open) (plates out of mesh)	Oscillator trimmer C1-D on gang
535 kc.	.1 mf.	12BE6, Pin 7		Capacitor fully closed	Check for adequate range
1400 kc.	—	Lay Generator lead near back of cabinet		Tune in 1400 kc. signal	Antenna trimmer C1-C on gang

MODELS CR-41A, -42A,
-43A, Ch. 4D16A

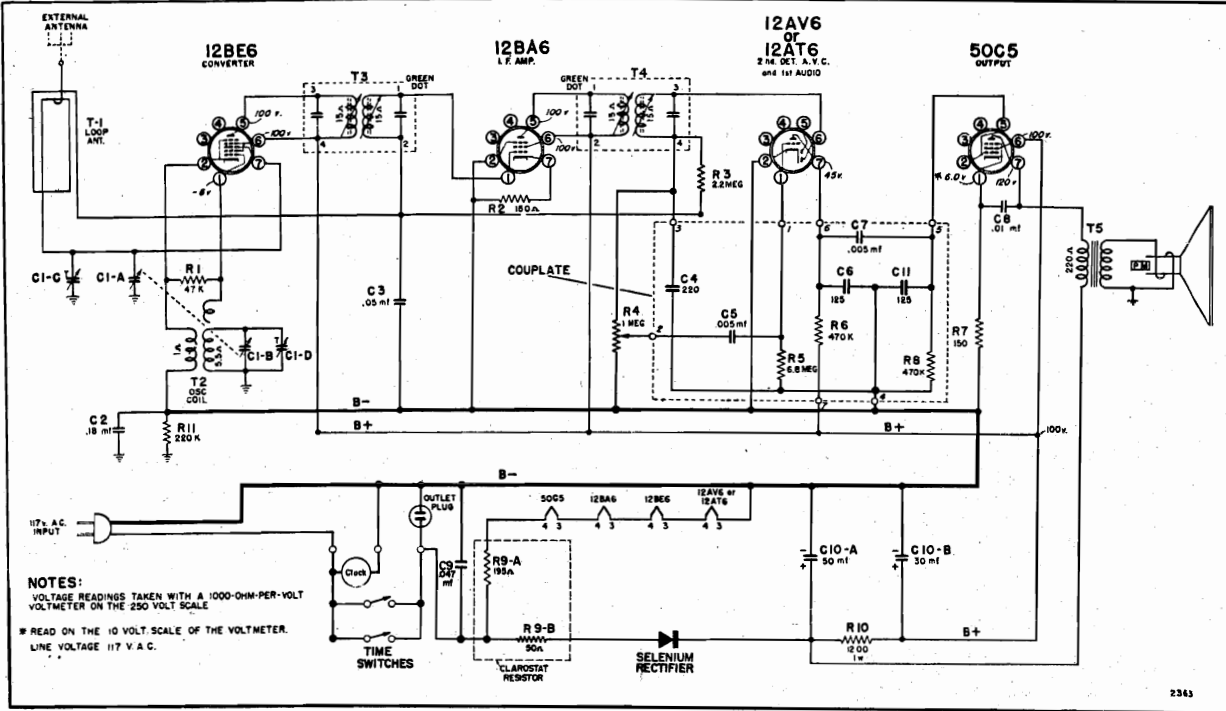

SCHEMATIC DIAGRAM

PARTS LIST

Please specify part number and chassis model number when ordering replacements.
Use only Genuine Factory Replacement Parts.

Ref. No.	Part No.	Description	Selling Price	Ref. No.	Part No.	Description	Selling Price
CAPACITORS							
C1A, B	8A-19740	2-gang condenser	\$3.00	49A-11324		Tension spring	.05
C1C, D		Trimmers on gang		21J-19594		Selenium rectifier	2.20
C2	8D-11111	.18 mfd. x 400 volts, paper	.35	R5C-19734-87		Cabinet (ivory)	5.65
C3	8D-14460	.05 mfd. x 200 volts, paper	.35	R5C-19734-86		Cabinet (mahogany)	4.05
C4	} (incl. in couplate)	220 mmf.		5C-19734-89		Cabinet (red)	5.75
C5		.005 mfd.		6A-20309		Dial glass	.75
C6, 11		125 mmf.		5B-20711-74		Clock knob (CR-41)	.05
C7		.005 mfd.		5B-20711-88		Clock knob (CR-42)	.05
C8	8D-17258	.01mfd. x 200 volts, paper	.25	5B-19794-74		Volume knob (mahogany)	.10
C9	8J-16081	.047 mfd. x 400 volts, paper	.30	5B-19795-74		Tuning knob (mahogany)	.30
C10A, B	8C-15262	Electrolytic condenser	1.80	5B-19794-88		Volume knob (ivory)	.10
C4, 5, 6, 7, 11	201-19303	Couplate	.90	5B-19795-88		Tuning knob (ivory)	.30
R5, 6, 8						85B-19794-90	
RESISTORS							
R1	9B1-82	47K ohms, 1/2 watt, 10%	.25	85B-19795-90		Knob-Tuning (red)	.30
R2, 7	9B1-52	150 ohms, 1/2 watt, 10%	.25	5B-20711-91		Knob (clock) (CR-43)	.05
R3	9B1-33	2.2 megohms, 1/2 watt, 20%	.25	23A-16328		Line cord lock	.05
R4	10B-19797	1. megohm volume control	.80	14M-20212		A.C. line cord and plug	1.40
R5	} (incl. in couplate)	6.8 megohms, 1/2 watt,		15C-16007		Tube socket, 7-prong miniature	.15
R6		470K ohms, 1/2 watt		2M-17589 or		Tube shield base	.05
R8		470K ohms 1/2 watt		2M-19187		Tube shield base	.05
R9A, B	9M-19778	195 ohms, 5 watts and 50 ohms, 5 watt, clarostat	.95	2M-17588 or		Tube shield	.10
R10	9B4-63	1200 ohms, 2 watts, 10%	.35	2M-19188		Tube shield	.10
R11	9B1-27	220K ohms, 1/2 watt, 20%	.25	19B-19802		A.C. receptacle	.30
TRANSFORMERS AND COILS							
T1	13E-20995	Loop antenna assembly	1.40	15B-10076		Lytic mounting base	.05
T2	13D-19064	Oscillator coil	.60	18A-19739		4" P.M. speaker	4.65
T3, 4	13B-17731	I. F. transformers	1.45	43D-20510		Tinnerman clip	.02
T5	12C-17595-1	Audio output transformer	1.00	29J-16690		Rubber washer	.02
MISCELLANEOUS							
	3A-19798	Tuning shaft	.45	42A8-20210		Chassis mounting bolt	.03
	49A-18851	Spring clip	.02	2M-10096		Cinch button (loop back)	.05
	2G-20329	Dial pointer	.30	3M-20268		Time set knob	.05
				2F-20616		Bezel	3.40
				2F-21022		Bezel	3.40
				21M-20996		Clock assembly (CR-41)	11.31
				21M-20997		Clock assembly (CR-43)	11.31
				23J-20343		Cardboard baffle	.05
				25E-19234		Rubber channel	.05
				38A-20854		Fibre barrier (UL)	.05
				9M-19778		Clarostat resistor	.95
				2C-21001		Dial scale (CR-41 & CR-42)	.35
				2C-21002		Dial scale (CR-43)	.45

MODELS R-51A,
-52A, Ch. 5D157-A

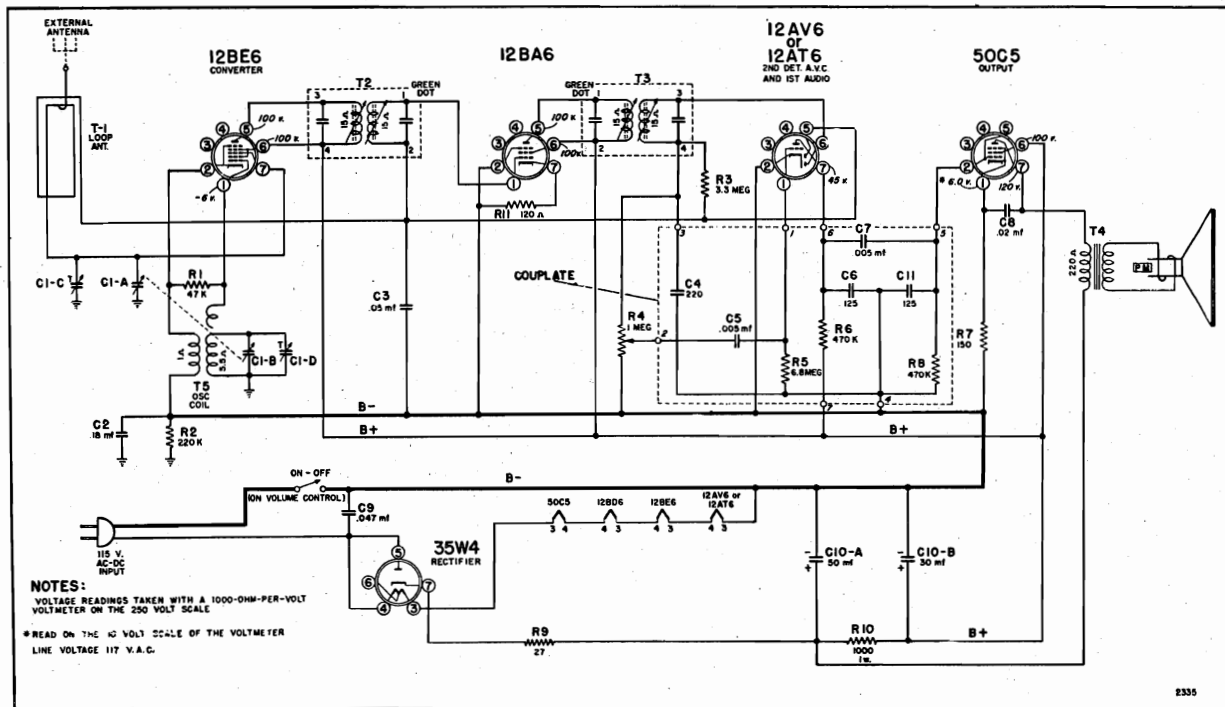

SCHEMATIC DIAGRAM

LIST OF PARTS

Please specify part number and chassis model number when ordering replacements.

Use only Genuine Factory Replacement Parts

Ref. No.	Part No.	Description	Price	Ref. No.	Part No.	Description	Price
Capacitors				Dial Parts			
C1A-B	8A-20992	2-gang condenser	\$2.85	3A-18166	Tuning shaft		\$.20
C1C-D		Trimmers on gang	—	40A-17591	Bushing		.05
C2	8D-11111	.18 mfd x 400 volts	.35	29E-17592	Spring washer		.05
C3	8D-10770	.05 mfd x 200 volts	.25	43D-17609	Tinnerman clip		.05
C4-5-6-7-11- and R5-6-8	201-19303	Couplate	.90	29C-10630	"C" washer		.05
C8	8D-10774	.02 mfd x 400 volts	.25	53A-18547	Dial string (approx 20")		.05
C9	8J-16081	.047 mfd x 400 volts	.30	49A-11324	Take up spring		.05
C10-A-B	8C-17391	Electrolytic condenser	1.25	2D-20217	Pointer bracket		.05
Resistors				Miscellaneous			
R1	9B1-82	47K ohms, 1/2 watt, 10%	.25	5C-20990-65	Cabinet (mahogany)		4.60
R2	9B1-27	220K ohms, 1/2 watt, 20%	.25	5C-20990-87	Cabinet (white)		5.95
R3	9B1-34	3.3 megohms, 1/2 watt, 20%	.25	5B-18164-74	Knob (mahogany)		.30
R4	10A-18126	Volume control and switch	1.05	5B-18164-88	Knob (white)		.30
R5-6-8		See Couplate		18A-17579	Speaker, 4" P.M.		2.64
R7	9B1-52	150 ohms, 1/2 watt, 10%	.25	2H-17588 or	Tube shield		.10
R9	9B1-43	27 ohms, 1/2 watt, 10%	.25	2H-19188	Tube shield		.10
R10	9B2-62	1000 ohms 1 watt, 10%	.30	2M-17589 or	Tube shield base		.05
R11	9B1-51	120 ohms, 1/2 watt, 20%	.25	2M-19187	Tube shield base		.05
Transformers and Coils				Speaker			
T1	13E-21028	Loop antenna assembly	1.40	2M-17580	I.F. locking clip		.05
T2-3	13B-17731	I.F. transformer	1.45	15C-16007	7-prong socket		.15
T4	12C-17595	Output transformer	1.00	15B-10440	Octal socket		.15
	OR 12C-19302			14M-10088-4	AC line cord and plug		1.00
T5	13D-17583	Oscillator coil	.70	2D-15432-2	Loop mounting bracket		.35
				23A-10344	Line cord lock		.05

MODEL PR-51A,
Ch. 4P12A

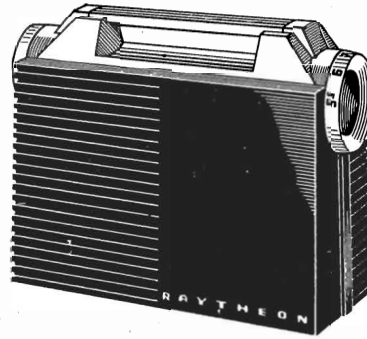

GENERAL DESCRIPTION

This model is a 3-way portable radio with 4 tubes plus a selenium rectifier and uses a built-in antenna. The receiver will operate on 115 volts, 50 to 60 cycles AC, or 115 volts DC, or on the self-contained batteries. When using the radio on AC, reversing the plug may reduce hum. If the radio does not operate in one minute on direct current (DC), reverse the plug. When bat-

tery operation is desired, the line cord plug is inserted into a socket switch on the chassis (see bottom cabinet view), the insertion automatically moves the switch contacts for battery operation. When the line cord plug is out of the chassis switch, the batteries are automatically disconnected.

SPECIFICATIONS

Power Supply.....115 volts, DC or 50-60 cycles AC,
25 watts.

A Battery—7.5 volts, 50 milli-
amperes.

B Battery—90 volts, 14 milli-
amperes

Frequency Range....540 to 1600 kc.

Intermediate Freq...455 kc.

Selectivity.....At 1000 kc., 60 kc. at 1000 x
signal

Sensitivity.....500 microvolts per meter

Power Output.....150 milliwatts, undistorted
250 milliwatts, maximum

Loud Speaker.....5" PM, v.c. impedance 3.2 ohms

Tube Complement....

1R5, Converter, 1U5, detector, AVC, audio amp.

1U4, I.F. amplifier, 3V4, output amplifier,

Rectifier.....Selenium type.

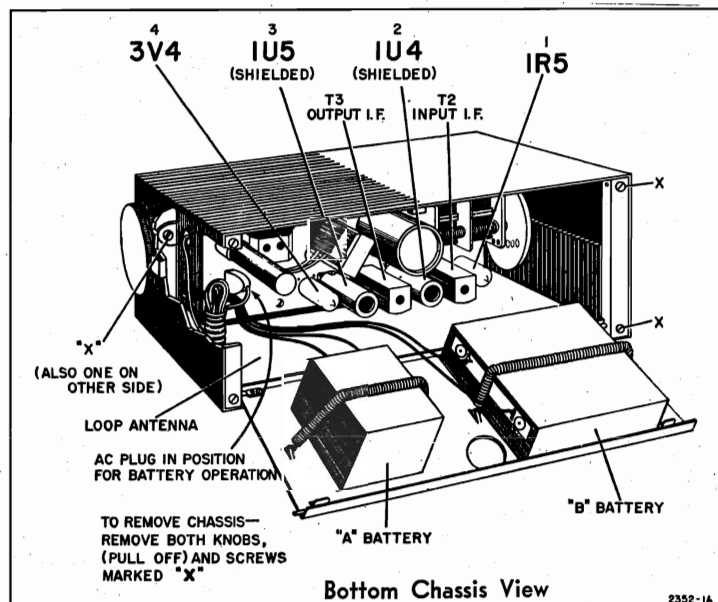

MODEL PR-51A,
Ch. 4P12A

Mfgr.	A	B
RCA	VS-065	VS-090
General	31	132
Ray-O-Vac	P-751	4390
Eveready	717	490
Burgess	C5	N60

BATTERY REPLACEMENT

Since the receiver is small and compact, not every A or B Battery will fit in the space provided. Listed to the left are the five most common manufactured types to be used for replacements.

CAUTION:

When battery operation is desired, the excess line cord length must be rolled up and placed in the position shown in the bottom chassis view above.

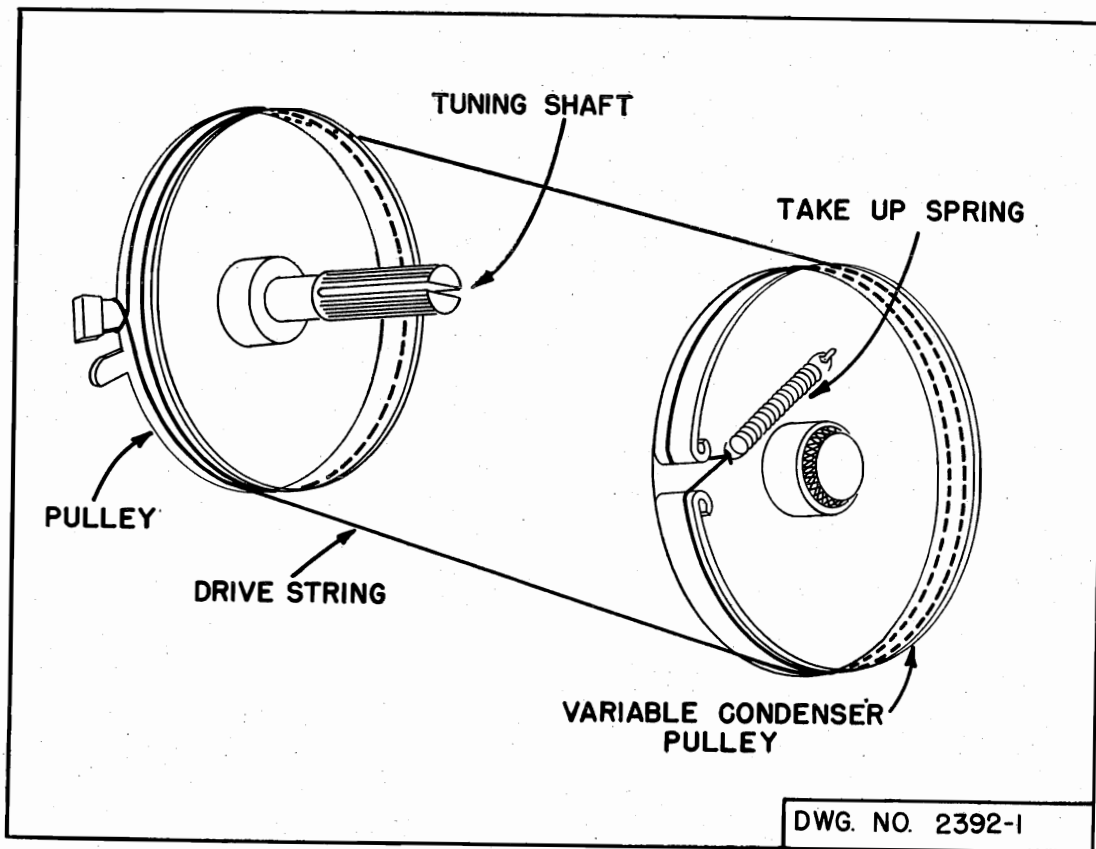

Dial Cord Stringing

ALIGNMENT PROCEDURE

The Alignment Procedure below includes the sensitivities at the input of various stage. All measurements are based on an output of 50 milliwatts. This may be measured by disconnecting the speaker voice coil and substituting a 3.2 ohm, 5 watt resistor across the secondary winding of the output transformer. A reading of .4 volts AC across this resistor will be equivalent to a

50 milliwatt output with speaker connected. The volume control must be set to maximum.

The signal source must be an accurately calibrated signal generator capable of supplying the frequencies designated, modulated 30% with a 400-cycle audio signal. A 400-cycle audio signal is required for the audio measurement. Variations in sensitivities of plus or minus 25% are usually permissible.

FREQUENCY	COUPLING CAPACITOR	DIAL SETTING	CONNECTION TO RADIO	GROUND CONNECTION	ADJUST	INPUT FOR 50 MILLIWATTS OUTPUT
455 kc.	.1 mfd.	1000 kc.	Pin No. 6 of 1R5	B— (shell of lytic)	I.F. slugs	100 microvolts
1620 kc.	.1 mfd.	1600 kc.	Pin No. 6 of 1R5	B— (shell of lytic)	C1-B Osc. Trim. on gang	—
1400 kc.	Radiation Loop	1400 kc.	Radiation loop	None	C-2 Antenna Trim. on gang	250 microvolts
400 cycles	.05 mfd.	—	Pin No. 6 of 1U5	B— (shell of lytic)	—	.040 volts
400 cycles	.05 mfd.	—	Pin No. 6 of 3V4	B— (shell of lytic)	—	3 volts

PARTS LIST

When ordering parts, specify part number and complete model number

Ref. No.	Part No.	Description	Price	Ref. No.	Part No.	Description	Price
Capacitors				Miscellaneous			
C1A-C	8A-21093	2 gang condenser	2.70	20A-19588	A.C. - D.C. battery switch	.90	
C1-B	—	Trimmer on gang	—	18A-19586	5" PM speaker	5.70	
C2	—	Trimmer on gang	—	21J-19615	Selenium rectifier	2.25	
C3	8G-14459	220 mmf, ceramic	.25	201-19996	Audio couplate	1.00	
C4, 5	8D-17268	.02 mfd x 200 volts	.25	201-15005	Filpec	.40	
C6	8D-18042	.25 mfd x 100 volts	.35	15C-16007	7 prong, miniature socket	.15	
C7	8D-17785	.005 mfd x 200 volts	.25	2H-17008	Tube shield base	.10	
C8	8G-13962	.005 mfd x 450 volts	.25	2H-19188	Tube shield	.10	
C9	8J-16081	.047 mfd x 400 volts	.30	14M-15724	A.C. line cord	.85	
C10A, B, C, D	8C-16068	40-200-40-50 mfd, lytic	2.95	5M-19963	Line cord lock	.10	
C11	8D-11251	.09 mfd x 400 volts	.25	14A-16919	"B" Battery cable	.35	
C12	8D-14460	.05 mfd x 200 volts	.35	14A-19846	"A" battery cable	.35	
Resistors				Cabinet Parts			
R1, 4, 15	9B1-104	3.3 megohms, 1/2 watt, 10%	.25	2M-19585	Clip, cabinet side channel	.40	
R2	9B1-86	100K ohms, 1/2 watt, 10%	.25	2M-19609	Bottom cover	.85	
R3	9B1-78	22K ohms, 1/2 watt, 10%	.25	49A-19612	Spring, battery	.20	
R5	9B1-108	6.8 megohms, 1/2 watt, 10%	.25	2M-19614	Stud	.10	
R6	10A-19596-1 or 10A-19596	Volume control and switch, 1 megohm	1.20	27C-6030	Rivet	.01	
R7, 8	9B1-155	680 ohms, 1/2 watt, 5%	.30	2D-19610	Bracket	.20	
R9	9B1-37	10 megohms, 1/2 watt, 20%	.25	2M-17580	I.F. clip	.05	
R10	9B1-159	1K ohms, 1/2 watt, 5%	.30	62D-19893	Antenna clip	.15	
R11	9C-19770	30 ohms, 2 watts, 10%	.20	6M-20077	Clamp, battery cable	.10	
R12	9B2-169	2700 ohms, 1 watt, 5%	.35	5C-21144-94	Cabinet (red)	4.25	
R13	9M-19833	2650 ohms, 10 watts, clarostat	.95	5C-21045-95	Escutcheon	1.45	
R14	C9B1-90	220K ohms, 1/2 watt, ±10%	.25	2D-21016	Handle bracket	.20	
R16	C-9B1-95	560K ohms, 1/2 watt, ±10%	.25	5M-20993-95	Handle	.75	
Coils, Transformers and Chokes				Speaker Parts			
T1	13E-19844	Loop antenna assembly	1.30	2M-21017	Handle strap	.35	
T2	13B-17397	Input I.F. transformer	1.45	38A-21173	Shield (fibre)	.05	
T3	13B-17397	Output I.F. transformer	1.45	2C-21104	Chassis shield	.35	
T4	12C-19591	Audio output transformer	1.85	3M-20246	Shoulder stud	.10	
T5	13D-19595	Oscillator coil	.80	41M-20124	Fibre spacer	—	
				29E-20247	Spring washer	.02	
				5B-21009-95	Volume knob	.70	
				5B-21154-95	Tuning knob	.85	
				200-21102	Tuning shaft assembly	1.00	
				2C-21103	Speaker shield (UL)	.15	

MODEL PR-51A,
Ch. 4P12A

3V4
AUDIO OUTPUT

IU5
DET.-A.V.C.-A.F.

IU4
I.F. AMP

IR5
CONVERTER

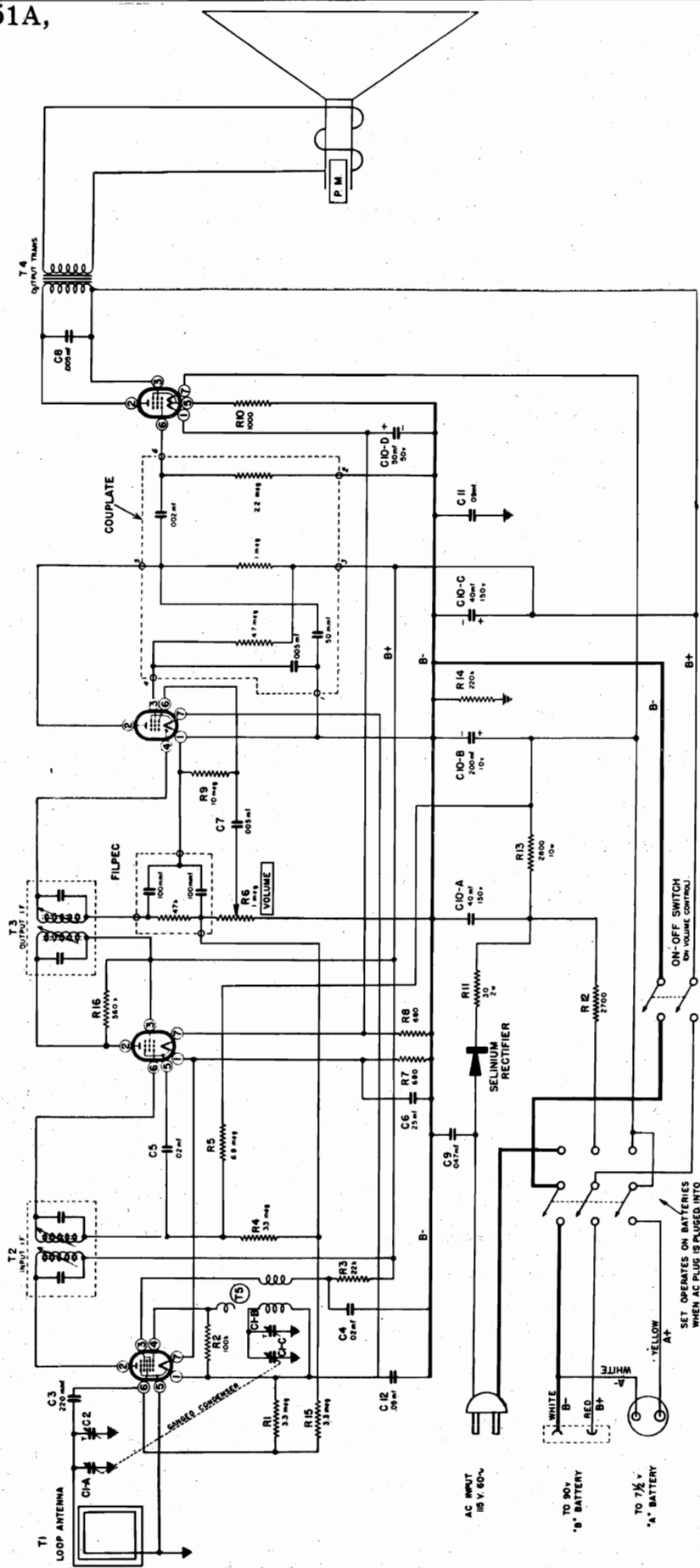

SCHEMATIC DIAGRAM

NOTE: R-13 is now 2650 ohms.
R-16 removed to increase sensitivity.
R-7 should be from pin 7 of tube 3 (IU5) to B-.

SPECIFICATIONS

MODELS 69, Ch. 100.201;
1066, Ch. 100.202

FREQUENCY RANGES:

AM—540 to 1700 Kc.
FM— 88 to 108 Mc.

TUNING CAPACITOR:

6 section gang (3-AM and 3-FM); entire
R.F. tuning assembly is rubber mounted.

I.F. FREQUENCY:

AM—455 Kc.
FM—10.7 Mc.

POWER SUPPLY:

117 volts A.C.
Radio— 85 watts
Phono—115 watts

POWER OUTPUT:

Undistorted—2.8 watts
Maximum —5.4 watt

SPEAKER:

12 inch P.M. Dynamic
Voice coil impedance—3.2 ohms

ANTENNAS:

AM—Low impedance loop
FM—Single ended half wave dipole

WEIGHT:

Packed—117 lbs.

DIMENSIONS:

Length—35½"
Height—34"
Depth—17¾"

1066, utilizes Radio Chassis 100.202. The chassis is the same as Radio chassis 100. 201. The only difference consists of a change in cabinet styling.

BROADCAST BAND—"AM"—ALIGNMENT PROCEDURE

1. Disconnect leads from FM-AM antenna terminal strip (labeled FM—FM—AM—AM) at back of chassis; also disconnect speaker leads and phono plugs. Remove chassis and speaker from cabinet. If desired, allow speaker to remain in cabinet and connect to receiver by extension leads.
2. Loop antenna leads (on cabinet) do not have to be connected to terminal strip on chassis while I.F. stages are being aligned. Before starting alignment of Ant., R.F., and Osc. stages, reconnect AM loop antenna leads to AM antenna terminal strip—do not attempt to use extension leads; place chassis as close as required to cabinet so that connections may be made direct to antenna terminal strip at back.
3. With the gang condenser fully meshed, dial pointer should be in the position indicated by the last division below 55 on the dial. If it is set incorrectly, hold tuning shaft steady and reposition pointer.
4. Connect an output meter across speaker voice coil, or from plate of 6V6GT tube to chassis through a 0.1 Mfd. condenser.
5. Connect ground lead of signal generator to the receiver chassis.
6. Set volume control to maximum volume position and use a weak signal from the signal generator.
7. Set band switch to the "AM" (middle) position.

DUMMY ANT. IN SERIES WITH SIGNAL GENERATOR	CONNECT HIGH SIDE OF SIGNAL GENERATOR TO	SIGNAL GENERATOR FREQUENCY	RECEIVER DIAL SETTING	TRIMMER OR SLUG NUMBER	TRIMMER DESCRIPTION	TYPE OF ADJUSTMENT																						
.1 MFD. Condenser	Lug on trimmer No. 6 at top of gang (see figure below for location of trimmer).	455 KC	Any point where it does not affect the signal.	1-2	2nd I.F.	Adjust for maximum output. Then repeat adjustment.																						
				3-4	1st I.F.		260 MMFD. Mica Condenser	External Antenna Clip	1500 KC	1500 KC	5	Broadcast Oscillator	Adjust for maximum output.	260 MMFD. Mica Condenser	External Antenna Clip	1500 KC	Tune to 1500 Kc. generator signal.	6	Broadcast R.F.	Adjust for maximum output.	7	Broadcast Antenna	Adjust for maximum output.	260 MMFD. Mica Condenser	External Antenna Clip	600 KC	Tune to 600 Kc. generator signal.	8
260 MMFD. Mica Condenser	External Antenna Clip	1500 KC	1500 KC	5	Broadcast Oscillator	Adjust for maximum output.																						
260 MMFD. Mica Condenser	External Antenna Clip	1500 KC	Tune to 1500 Kc. generator signal.	6	Broadcast R.F.	Adjust for maximum output.																						
				7	Broadcast Antenna	Adjust for maximum output.																						
260 MMFD. Mica Condenser	External Antenna Clip	600 KC	Tune to 600 Kc. generator signal.	8	Adjustable core of Broadcast R.F. Coil.	Adjust for maximum output.																						
				9	Adjustable core of Broadcast Antenna Coil.	Adjust for maximum output.																						

Repeat adjustment of trimmers 6 & 7 and slugs 8 & 9 until one no longer detunes the other.

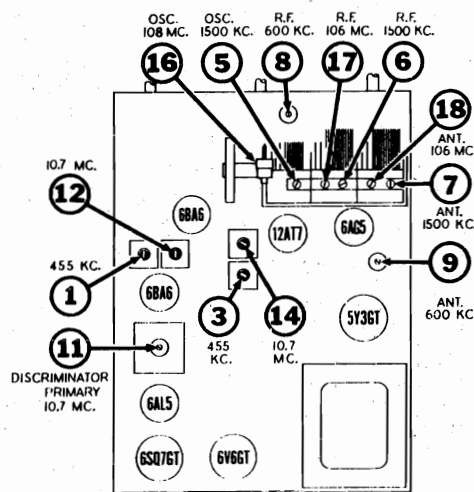

FIG. 1
Top View of Chassis

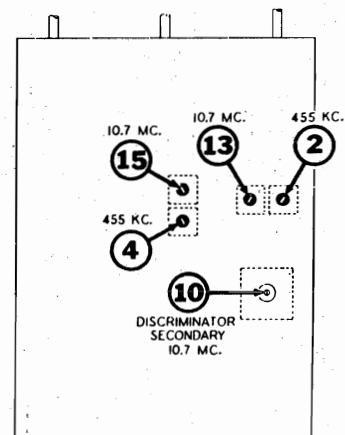

FIG. 2
Bottom View of Chassis

613

MODELS 69, Ch. 100.201;
1066, Ch. 100.202

FREQUENCY MODULATION—"FM"—ALIGNMENT PROCEDURE

1. If alignment of both AM and FM channels is required it is necessary to align the AM channel first, then align the FM channel as instructed in chart below (AM alignment procedure is given on the preceding page).
2. Disconnect all leads from antenna terminal strip (labeled FM—FM—AM—AM) at back of chassis; also disconnect speaker leads and phono plugs. Remove chassis and speaker from cabinet. If desired, allow speaker to remain in cabinet and connect to receiver by extension leads.
3. With the gang condenser fully meshed, dial pointer should be in the position indicated by the last division below 88 on the dial. If it is set incorrectly, hold tuning shaft steady and reposition pointer.
4. Set volume control at maximum volume position and use a weak signal from the signal generator.
5. Dress FM circuit leads as short and straight as possible, particularly those in the oscillator circuit. I.F. plate and grid leads should also be kept short and straight.
6. Set band switch to the FM (extreme counter-clockwise) position.

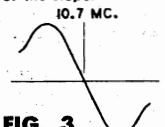
STANDARD SIGNAL GENERATOR		SWEEP GENERATOR		VTVM OR OUTPUT METER CONNECTIONS	OSCILLOSCOPE CONNECTIONS	RECEIVER DIAL SETTING	TRIMMER OR SLUG NUMBER	TYPE OF ADJUSTMENT AND OUTPUT INDICATION
CONNECTIONS	FREQUENCY	CONNECTIONS	FREQ.					
Connect high side to lug on trimmer #17 (see Fig. 1 for location of trimmer) using a .01 Mfd. condenser in series with generator lead. Connect ground lead to the receiver chassis in vicinity of gang condenser.	10.7 MC. Unmodulated	Not used.	—	Connect VTVM as shown in Fig. 4.	Not used.	Any position where it does not affect the signal.	#10 Discriminator secondary #11 Discriminator primary #12-13 2nd IF #14-15 1st IF	Adjust these trimmers for maximum meter reading — the output voltage will be of negative polarity.
Same as above.	Same as above.	Not used.	—	Connect VTVM as shown in Fig. 5.	Not used.	Same as above.	#10 Discriminator secondary	Note that as slug #10 is rotated, a point will be found where the voltmeter will swing rather sharply from a positive to a negative reading or vice versa. The correct setting is obtained when the meter reads zero as the slug is moved thru this point.
Same as above.	Same as above. Attenuate signal to prevent overload and distortion of response curve.	Connect high side to lug on trimmer #17 (see Fig. 1 for location of trimmer) using a .01 Mfd. condenser in series with generator lead. Connect ground lead to the receiver chassis in vicinity of gang condenser.	10.7 MC Sweeping ±300 Kc.	Not used.	Connect as shown in Fig. 5. Set vertical amplifier of scope for maximum amplification. Synchronize oscilloscope with sweep generator by connecting "horizontal input" terminals of scope to source of horizontal sweep modulating voltage on the sweep generator.	Same as above.	#10 Discriminator secondary	A pattern similar to that shown in Fig. 3 should appear on the oscilloscope screen. Check for symmetry about the 10.7 Mc. center point and linearity of the slope. 10.7 MC.  FIG. 3 If the characteristic is not shaped properly, attempt to obtain symmetry by changing the setting of slug #10. Should that fail to produce the desired results, then a slight readjustment of slugs #11, 12, 13, 14 and 15 should be undertaken.

MODELS 69, Ch. 100. 201;
1066, Ch. 100. 202

FREQUENCY MODULATION—"FM"—ALIGNMENT PROCEDURE (Continued)

STANDARD SIGNAL GENERATOR		SWEEP GENERATOR		VTVM OR OUTPUT METER CONNECTIONS	OSCILLOSCOPE CONNECTIONS	RECEIVER DIAL SETTING	TRIMMER OR SLUG NUMBER	TYPE OF ADJUSTMENT AND OUTPUT INDICATION
CONNECTIONS	FREQUENCY	CONNECTIONS	FREQ.					
Connect generator "high" side in series with a 270 ohm carbon resistor to end terminal marked "FM" on strip at back of chassis. Generator ground lead must connect to next terminal marked "GND."	108 MC. with 400 cycle AM Modulation.	Not used.	—	Connect VTVM as shown in Fig. 5.	Not used.	108 MC.	#16 FM Oscillator	Set trimmer #16 to receive 108 Mc. signal as indicated by maximum meter reading.
Same as above.	106 MC. with 400 cycle AM Modulation.	Not used.	—	Same as above.	Not used.	Tune to 106 Mc. generator signal.	#13 FM RF #18 FM ANT.	Adjust trimmer for maximum meter reading.

Check calibration and tracking of receiver with input signals of 88, 98 and 106 MC. If difference between dial pointer setting and these frequencies does not exceed ± 0.3 MC. and R.F. circuit is tracking properly, then alignment may be considered satisfactory and no further adjustment is necessary. Where the calibration error is greater than ± 0.3 MC., it is advisable to make the following adjustments:

Tune receiver to an 88 MC. signal and note whether dial pointer is above or below correct calibration point. Then tune receiver so that dial pointer is at the 88 MC. position. If generator signal was previously received at a setting above 88 MC., it will be necessary to slightly spread the windings of the FM oscillator coil so that signal will now be received at the correct dial setting. On the other hand, if generator signal was received at a

dial setting below 88 MC., then slightly compress the windings of the oscillator coil until the signal comes in at the correct calibration point.

Check calibration at 108 MC. and if it is in error by more than ± 0.3 MC., readjust setting of trimmer #16. Then repeat adjustments of trimmers #17 and 18 at 106 MC. Repeat calibration adjustment at 88, 106 and 108 MC. until desired accuracy is obtained.

Observe dial calibration at 106 MC. If it is found to be incorrect by an appreciable amount, then make a very slight adjustment in the spacing of the gang condenser plates to receive the 106 MC. signal at the correct dial setting. Then check adjustment of R.F. trimmer #17 and ANT. trimmer #18 to obtain maximum output indication at 106 MC.

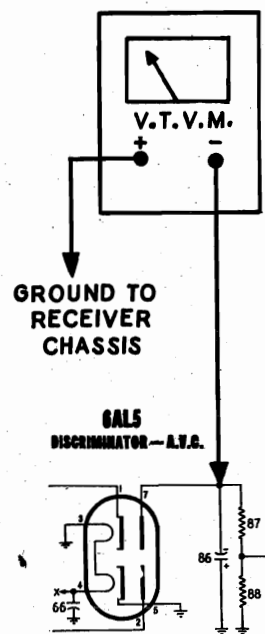

FIG. 4
VTVM Connections
for I.F. Alignment

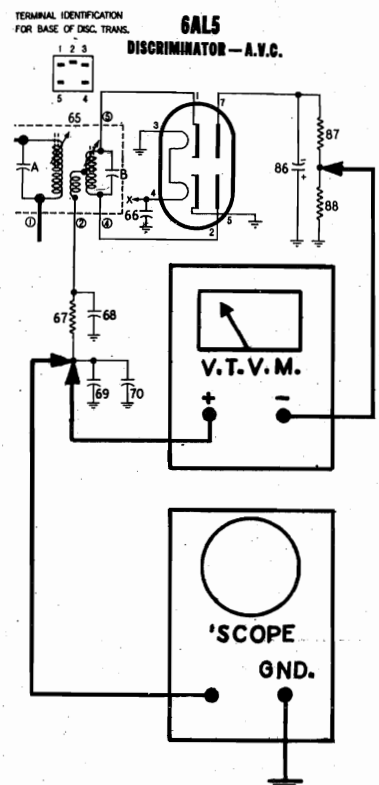

FIG. 5
VTVM and Oscilloscope
Connections for
Discriminator Alignment

MODELS 69, Ch. 100. 201;
1066, Ch. 100. 202

SOCKET VOLTAGES
THE VOLTAGE SHOWN IN THIS CHART WERE MEASURED
UNDER THE FOLLOWING CONDITIONS

1. Power Supply—117 volts 60 cycles A.C.
2. All voltages are measured between socket terminals and chassis unless otherwise indicated on the chart.
3. All measurements made with a voltmeter having a sensitivity of 1000 ohms per volt except where indicated by (*). The (*) symbol designates a vacuum tube voltmeter measurement.
4. Where a particular voltage is dependent upon band switch position, the value shown on the chart carries a letter suffix which is interpreted as follows (no suffix letter indicates that voltage is the same for any of the three switch positions).
5. When measuring FM voltages, receiver should be tuned to 88 Mc.
6. When measuring AM voltages, receiver should be tuned to 540 Kc.
7. All terminals on strip labeled "FM—FM—AM—AM" at rear of chassis are shorted together by using a jumper wire.
8. Volume control set to maximum position with no signal.
9. Tone control set to maximum clockwise position.

"A" indicates band switch set to "AM" (center) position.
"F" indicates band switch set to "FM" (counter-clockwise) position.
"P" indicates band switch set to "PHO" (clockwise) position.

BOTTOM VIEW OF CHASSIS

117 VOLT 60 CYCLE A.C.
POWER SUPPLY USED
FOR THESE MEASUREMENTS.
ALL VOLTAGES MEASURED BETWEEN
SOCKET TERMINALS AND CHASSIS
UNLESS OTHERWISE INDICATED.

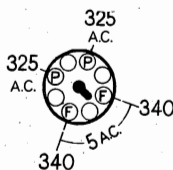
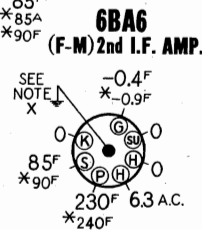
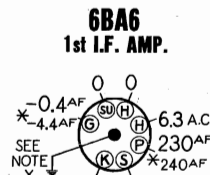
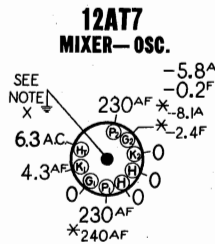
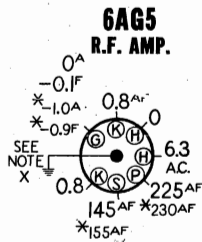

5Y3GT
RECTIFIER

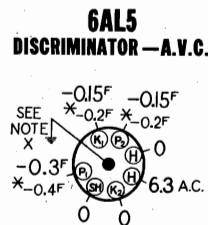

6V6GT
OUTPUT

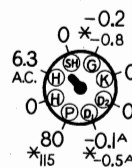

6SQ7GT
A.F.—(A-M) DET.—A.V.C.

REAR OF CHASSIS

NOTE X: Grounding of center stud on tube socket is necessary to reduce capacity coupling between other pins. Oscillation may result if this ground is omitted.

MODELS 69, Ch. 100.201;
1066, Ch. 100.202

WIRING DIAGRAM FOR SILVERTONE CHASSIS 100.201

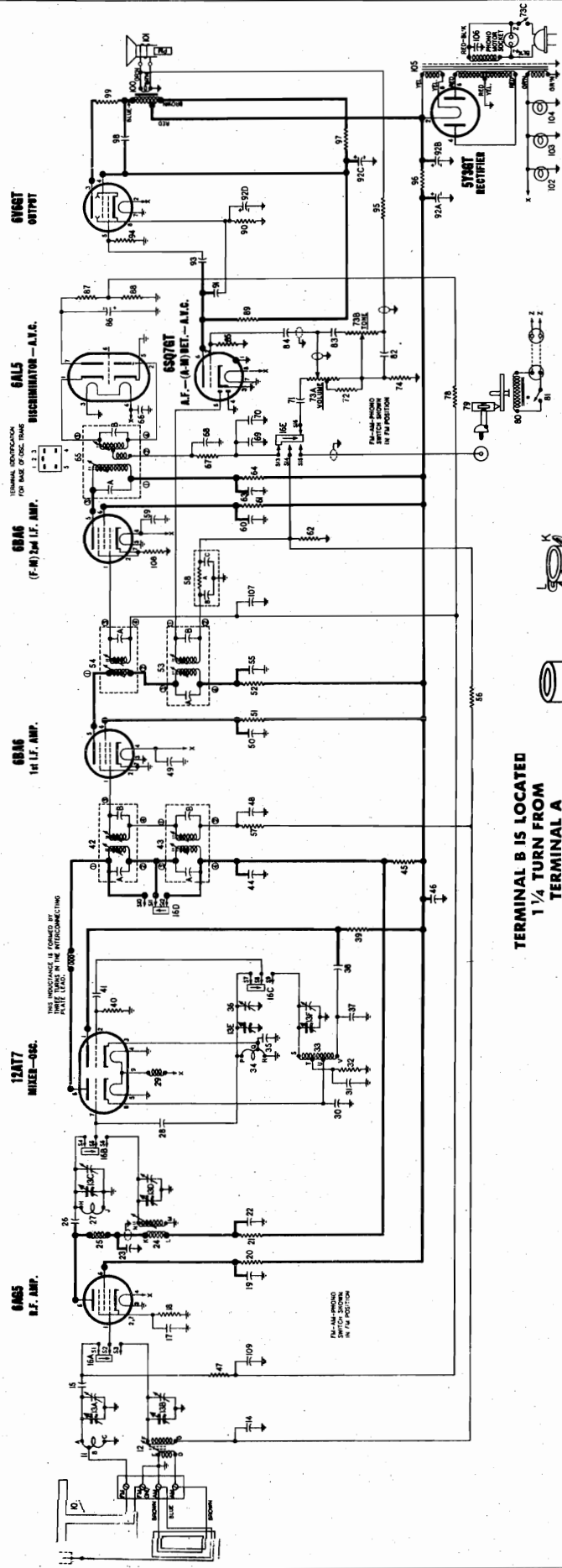

DIAL AND POINTER DRIVE CORD ARRANGEMENT
SIDE VIEW

To string dial cord, set gang condenser to fully open position and use the following parts:
 W114955 Clip on end of cord
 W117057 Cord (3 feet)
 W119087 Ring for dial cord
 W505161 Tension spring

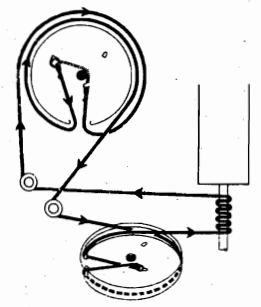

TERMINAL B IS LOCATED 1 1/4 TURN FROM TERMINAL A

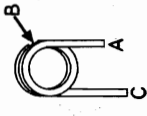

FM ANT. COIL W506353

TERMINAL Q IS LOCATED 7/8 TURN FROM TERMINAL R

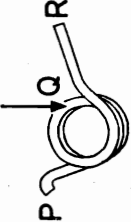

FM OSC. COIL W506352

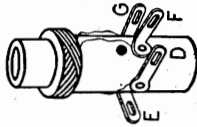

AM ANT. COIL W506354

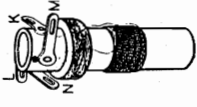

AM R.F. COIL W506345

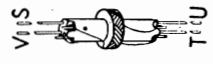

AM OSC. COIL W506335

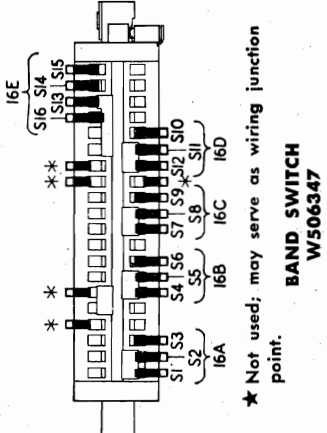

* Not used; may serve as wiring junction point.
BAND SWITCH W506347

Lettered terminals in illustrations correspond to similarly lettered terminals on the circuit diagram.

MODELS 69, Ch. 100. 201 HOW TO ORDER PARTS
1066, Ch. 100. 202

1. Use Correct Order Form.
2. On the Purchase Order always give the following information:
 - (a) PART NUMBER (number printed on the part if different from that shown in this list) and DESCRIPTION for each part ordered. When no part number is assigned, order by description and rating. Also give PRICE of part (indicate if no selling).
 - (b) The CHASSIS NUMBER, which is 100.201, will be found on a metal plate at the rear of the chassis.
3. In all correspondence relating to cabinets, always mention the source code letter stamped into the upper rear rail of consoles or the bottom of table models, and the CATALOG NUMBER shown on the sticker on the back, bottom or inside of cabinet.

PARTS LIST FOR CHASSIS

Notice: Some parts listed below have special characteristics. Do not use substitutes for replacement purposes.

SCHE-MATIC LOCA-TION	PART NO.	DESCRIPTION	LIST PRICE	SCHE-MATIC LOCA-TION	PART NO.	DESCRIPTION	LIST PRICE
CONDENSERS				RESISTORS—Continued			
13-A to F	W506348	Condenser—variable gang (with drum)	\$ 9.50	93	W512009	Condenser—.01 Mfd. 200 volt	.25
14	W512027	Condenser—.05 Mfd. 200 volt	.40	98	W512001	Condenser—.001 Mfd. 600 volt	.22
15	W513406	Condenser—ceramic 22 Mmfd. 500 volt (Temperature compensating)	.30	106	W512256	Condenser—.01 Mfd. 600 volt	.30
17	W513002	Condenser—ceramic 47 Mmfd. 500 volt	.24	107	W513013	Condenser—ceramic 5000 Mmfd. 450 volt	.36
19	W513013	Condenser—ceramic 5000 Mmfd. 450 volt	.36	109	W513013	Condenser—ceramic 5000 Mmfd. 450 volt	.36
22	W513013	Condenser—ceramic 5000 Mmfd. 450 volt	.36	RESISTORS			
23	W513002	Condenser—ceramic 47 Mmfd. 500 volt	.24	18	W510117	Resistor—carbon 82 Ohms ± 10% 1/2 watt	.12
26	W513401	Condenser—ceramic 5 Mmfd. ± 10% 500 volt (Temperature compensating)	.50	20	W510164	Resistor—carbon 33,000 Ohms 1/2 watt	.12
28	W513000	Condenser—ceramic 1.0 Mmfd. 500 volt	.15	21	W510237	Resistor—carbon 1000 Ohms 1 watt	.16
30	W513007	Condenser—ceramic 330 Mmfd. 500 volt	.25	32	W510141	Resistor—carbon 1800 Ohms ± 10% 1/2 watt	.12
31	W512009	Condenser—.01 Mfd. 200 volt	.25	39	W510249	Resistor—carbon 4700 Ohms 1 watt	.16
35	W513429	Condenser—ceramic 10 Mmfd. ± 10% 500 volt (Temperature compensating)	.30	40	W510155	Resistor—carbon 10,000 Ohms 1/2 watt	.12
36	W506336	Condenser—trimmer; 3 to 30 Mmfd.	.75	45	W510237	Resistor—carbon 1000 Ohms 1 watt	.16
37	W513442	Condenser—ceramic 10 Mmfd. ± 10% 500 volt (Temperature compensating)	.40	47	W510167	Resistor—carbon 47,000 Ohms 1/2 watt	.12
38	W513013	Condenser—ceramic 5000 Mmfd. 450 volt	.36	51	W510165	Resistor—carbon 39,000 Ohms ± 10% 1/2 w.	.12
41	W513409	Condenser—ceramic 39 Mmfd. ± 5% 500 volt (Temperature compensating)	.30	52	W510237	Resistor—carbon 1000 Ohms 1 watt	.16
42-A	W506080	Condenser—ceramic 33 Mmfd. (part of 1st FM I.F. transformer)	2.05	56	W510193	Resistor—carbon 2.2 Meg. 1/2 watt	.12
42-B	W506080	Condenser—ceramic 72 Mmfd. (part of 1st FM I.F. transformer)	2.05	57	W510173	Resistor—carbon 100,000 Ohms 1/2 watt	.12
43-A, B	W506333	Condenser—ceramic 330 Mmfd. (part of 1st AM I.F. transformer)	2.15	58-A	W506338	Resistor—carbon 47,000 Ohms (part of diode filter unit)	.45
44	W513013	Condenser—ceramic 5000 Mmfd. 450 volt	.36	61	W510165	Resistor—carbon 39,000 Ohms ± 10% 1/2 w.	.12
46	W513013	Condenser—ceramic 5000 Mmfd. 450 volt	.36	62	W510185	Resistor—carbon 470,000 Ohms 1/2 watt	.12
48, 49, 50	W513013	Condenser—ceramic 5000 Mmfd. 450 volt	.36	64	W510237	Resistor—carbon 1000 Ohms 1 watt	.16
53-A	W505797	Condenser—ceramic 107 Mmfd. (part of 2nd AM I.F. transformer)	2.15	67	W510159	Resistor—carbon 18,000 Ohms ± 10% 1/2 w.	.12
53-B	W505797	Condenser—ceramic 86 Mmfd. (part of 2nd AM I.F. transformer)	2.15	72	W510170	Resistor—carbon 68,000 Ohms 1/2 watt	.12
54-A	W505905	Condenser—ceramic 83 Mmfd. (part of 2nd FM I.F. transformer)	2.05	73-A, B, C	W508483	Volume and tone control A—2 Meg. B—2 Meg. C—"ON-OFF" switch	2.50
55	W513013	Condenser—ceramic 5000 Mmfd. 450 volt	.36	74	W510128	Resistor—carbon 330 Ohms 1/2 watt	.12
58-B, C	W506338	Condenser—ceramic 100 Mmfd. (part of diode filter unit)	.45	78	W510193	Resistor—carbon 2.2 Meg. 1/2 watt	.12
59, 60	W513013	Condenser—ceramic 5000 Mmfd. 450 volt	.36	85	W510195	Resistor—carbon 4.7 Meg. 1/2 watt	.12
63	W513013	Condenser—ceramic 5000 Mmfd. 450 volt	.36	87, 88	W510153	Resistor—carbon 8200 Ohms ± 10% 1/2 watt	.12
65-A	W506332	Condenser—ceramic 8 Mmfd. (part of discriminator transformer)	4.20	89	W510179	Resistor—carbon 220,000 Ohms 1/2 watt	.12
65-B	W506332	Condenser—ceramic 47 Mmfd. (part of discriminator transformer)	4.20	90	W510128	Resistor—carbon 330 Ohms 1/2 watt	.12
66	W513013	Condenser—ceramic 5000 Mmfd. 450 volt	.36	94	W510185	Resistor—carbon 470,000 Ohms 1/2 watt	.12
68	W513007	Condenser—ceramic 330 Mmfd. 500 volt	.25	95	W510148	Resistor—carbon 4700 Ohms ± 10% 1/2 watt	.12
69	W512005	Condenser—.003 Mfd. 600 volt	.25	96	W510732	Resistor—wire wound 2000 Ohms ± 10% 10 watts	.95
70	W513003	Condenser—ceramic 100 Mmfd. 500 volt	.24	97	W510261	Resistor—carbon 22,000 Ohms 1 watt	.16
71	W512027	Condenser—.05 Mfd. 200 volt	.40	99	W510113	Resistor—carbon 47 Ohms 1/2 watt	.12
82	W512033	Condenser—.1 Mfd. 200 volt	.30	108	W510115	Resistor—carbon 68 Ohms ± 10% 1/2 watt	.12
83	W512001	Condenser—.001 Mfd. 600 volt	.22	TRANSFORMERS AND COILS			
84	W512009	Condenser—.01 Mfd. 200 volt	.25	10	W508395	Antenna—built-in (FM)	.50
96	W504937	Condenser—electrolytic 5 Mfd. 50 volt	.80	11	W506353	Coil—FM Antenna	.15
91	W513008	Condenser—ceramic 470 Mmfd. 350 volt	.30	12	W506354	Coil—AM Antenna	2.20
92-A, B, C, D	W505908	Condenser—electrolytic A—30 Mfd. 450 volt B—40 Mfd. 450 volt C—10 Mfd. 450 volt D—20 Mfd. 25 volt	3.75		W506349	Slug core for AM antenna coil	.18
				24	W506345	Coil—AM R.F.	2.25
					W506344	Slug core for AM R.F. coil	.18
				25	W507935	Coil—choke	.40
				27	W506351	Coil—FM R.F.	.15
				29	W507586	Coil—choke	.28
				33	W506335	Coil—AM Oscillator	1.30
				34	W506352	Coil—FM Oscillator	.15

*—This part is not supplied as a Service replacement item.

MODELS 69, Ch. 100.201;
1066, Ch. 100.202

SCHE- MATIC LOCA- TION	PART NO.	DESCRIPTION	LIST PRICE	SCHE- MATIC LOCA- TION	PART NO.	DESCRIPTION	LIST PRICE
OTHER ELECTRICAL PARTS—Continued				CABINET PARTS—Continued			
42	W506080	Transformer—1st FM I.F.	2.05	W509052	Record changer base assembly	16.50	
43	W506333	Transformer—1st AM I.F.	2.15	W508990	Rod—tie; for record changer pull-out mechanism	1.00	
53	W505797	Transformer—2nd AM I.F.	2.15	W160496	Rubber pad between dial plate and retaining bracket	.08	
54	W505905	Transformer—2nd FM I.F.	2.05	W160496	Rubber pad for mounting chassis	.08	
65	W506332	Transformer—discriminator	4.20	W118621	Rubber pad for record changer pull-out mechanism	.06	
	W508841	Slug core for primary or secondary of discriminator transformer	.20	W170167	Screw—#8-32x7/8"; for mounting chassis	.02	
100	W508486	Transformer—output	2.60	W508480	Socket for indicator lamp at base of cabinet (with leads)	.55	
105	W506709	Transformer—power	11.00	W506760	Spring—compression for record changer pull-out mechanism and radio compartment tilt mechanism	.05	
OTHER ELECTRICAL PARTS				MISCELLANEOUS PARTS			
16-A to E	W506347	Switch—FM-AM-Phono	2.40	W508986	Background for dial (foil)	.50	
58-A,B,C	W506338	Diode filter unit		W301270	Base for mounting electrolytic condenser	.06	
		A—Resistor-carbon 47,000 Ohms 1/2 watt	.45	W505165	"C" washer for tuning shaft or pointer shaft	.02	
		B—Condenser-ceramic 100 Mmfd. 400 volt		W508488	Clamp—retains dial scale	.10	
		C—Condenser-ceramic 100 Mmfd. 400 volt		W506343	Clip for mounting AM antenna or R.F. coil	.08	
79	W509160	Cartridge	8.60	W505101	Clip for mounting I.F. transformer	.05	
80	W509301	Motor—115 volt 60 cycle	12.40	W160326	Clip—retains dial background	.02	
81	W509205	Switch—"ON-OFF" for record changer	.65	W114955	Clip—retainer on end of dial cord	.01	
101	W505512	Speaker—P.M. Dynamic (12 inch)	15.75	W117057	Cord—dial drive (3 ft. required)	per ft. .05	
102	W118921	Lar.p—dial (Mazda 47) 6-8 volt 150 Ma.	.15	W508985	Dial scale—glass	2.20	
103				W501031	Plug for phono, motor cable	.15	
104				W500966	Plug for phono, pick-up cable	.10	
CABINET PARTS				W506370	Pointer	.15	
W508217	Bracket for mounting OFF-ON indicator lite at base of cabinet	.10	W119087	Ring for dial cord	.01		
W508487	Bracket—retains dial plate	.10	W 38501	Rubber bushing for band switch	.03		
W506757	Bracket—slide; retains radio compartment	.50	W116584	Rubber spacer for mounting dial scale	.04		
W508991	Bracket—tie for record changer pull-out mechanism	.12	W503588	Shaft and drum for dial	.20		
W117131	Bull's-eye for OFF-ON indicator lite at base of cabinet	.50	W162148	Shaft and link assembly; Band switch	.65		
W508880	Cabinet	165.00	W508485	Shaft—tuning	.25		
W508499	Catch for record storage compartment	.65	W506349	Slug core for AM antenna coil	.18		
W508996	Door and radio tilt compartment assembly (less hardware)	26.50	W506344	Slug core for AM R.F. coil	.18		
W508995	Door for record changer compartment (less hardware)	16.60	W508841	Slug core for primary or secondary of discriminator transformer	.20		
W508997	Door for record storage compartment (less hardware)	17.00	W505307	Socket and phono, motor cable	.50		
W508493	Escutcheon—dial	2.80	W506372	Socket—dial lamp; pair (with lead)	.50		
W506380	Fastener for loop antenna	.02	W504597	Socket—miniature (7 pin)	.30		
W508497	Handle for radio or record changer door	1.80	W506331	Socket—miniature (9 pin)	.60		
W508998	Handle for record storage compartment door	1.80	W116690	Socket—octal base	.15		
W506640	Hinge—for record storage compartment; per pair	.65	W160392	Socket—octal (rectifier)	.16		
W509046	Knob—"PHO. AM FM"	.40	W160039	Socket—phono, plug	.12		
W509044	Knob—"TONE"	.30	W505161	Spring—dial cord tension	.08		
W509045	Knob—"TUNE"	.40	W505924	Terminal strip (FM-FM-AM-AM)	.25		
W509043	Knob—"VOLUME-ON"	.25	W111456	Washer—spring washer for tuning shaft or pointer shaft	.01		
W170188	Nut—Wing #10-24; for tension adjustment of radio compartment tilt mechanism	.10					
W507809	Nut—wing #10-32; for tension adjustment on record changer pull-out mechanism	.15					
W508397	Pivot bolt for radio tilt compartment	.10					
W508981	Pull-out mechanism for record changer compartment (left side)	6.50					
W508982	Pull-out mechanism for record changer compartment (right side)	6.50					

*—This part is not supplied as a Service replacement item.

PART NO.	DESCRIPTION	SELLING PRICE
W520145	Cabinet	\$150.00
W520163	Door and radio tilt compartment (less hardware)	10.00
W520162	Door for record changer compartment (less hardware)	10.00
W520164	Door for record storage compartment (less hardware)	14.00
W520165	Handle for radio or record changer door	1.50
W520166	Handle for record storage compartment door	.45

MODEL 4,
Ch. 478. 233

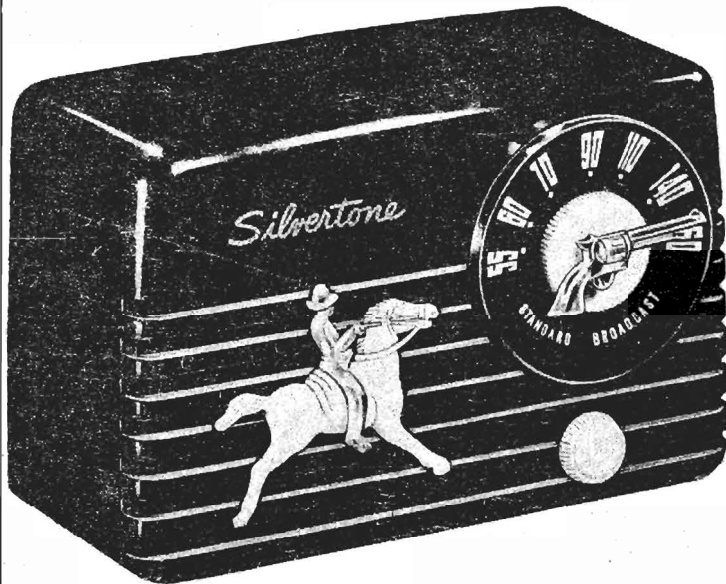

ELECTRICAL SPECIFICATIONS

- Power Supply** 105-125 Volts D.C. or
105-125 Volts, 50-60
Cycles A.C.,
30 Watts
- Frequency Range** 532.5 to 1620 kc.
- Intermediate Freq.** 455 kc.
- Tuning** Two gang capacitor
- Speaker** 4 inch PM 3.2 ohm
voice coil impedance
- Power Output** 1 watt undistorted
1.5 watt maximum
- Sensitivity** 800 Microvolts at 50
milliwatts Output
- Selectivity** 120 kc broad at 1000
times signal at 1000
kc.

ALIGNMENT PROCEDURE

PRELIMINARY:

- Output meter connection Across 3.2 ohm speaker voice coil
- Output meter reading to indicate 0.05 watt across speaker voice coil 0.4 volt
- Generator Modulation 30%, 400 cycles
- Position of volume control maximum (fully clockwise)
- Position of pointer with Rotor full open (Plates out of mesh) slightly beneath
the 1620 kc calibration mark on the
dial (pointer horizontal to right)

Position of Tuner	SIGNAL GENERATOR				Trimmer Adjustments (In order shown)
	Frequency	Coupling Factor	Connection to Receiver	Ground Connection	
Rotor Full Open (Plates out of mesh)	455 kc.	.1 mfd	Grid of 12BE6 (Pin 7)	Chassis	Input and Output Trimmers on I.F. Can T3 and T4 Oscillator Trimmer T2
Rotor Full Open (Plates out of mesh)	1620 kc.	.1 mfd	Grid of 12BE6 (Pin 7)	Chassis	
1400 kc.	1400 kc.	75 mmf	Antenna Hank	Chassis	Antenna Trimmer T1
600 kc.	600	75 mmf	Antenna Hank	Chassis	(Check Point)*

*With a generator frequency of 600 Kc, tune the set to the point where maximum output is obtained, which should be approximately 600 Kc on the dial.

Align for maximum output. Reduce input as needed to keep output near 0.4 volts.

The alignment procedure should be done in the order given for greatest accuracy.

Always keep the output from the generator at its lowest possible value to prevent the AVC of the receiver from interfering with accurate alignment.

ANTENNA SYSTEM

This radio unit is equipped with a hank of antenna wire attached to the antenna coil. For normal reception, unhook the antenna wire and stretch it around the room or permit it to hang outside the window.

In areas where reception is poor due to weak signal strength, an additional external antenna can be connected to the antenna wire.

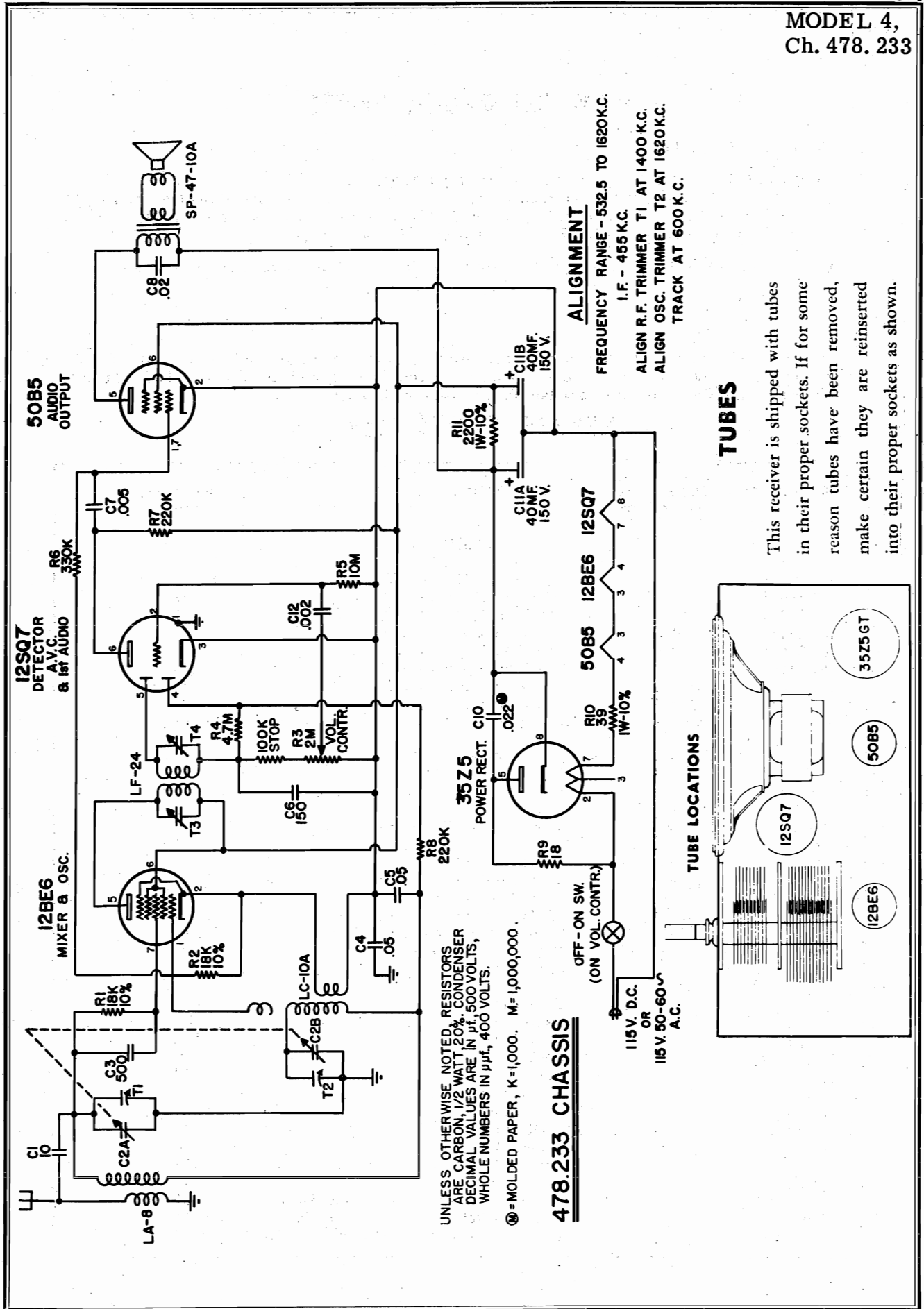

MODEL 4, Ch.
478. 233

HOW TO ORDER PARTS

1. Use Correct Order Form.
2. On the Purchase Order always give the following information:
 - (1) PART NUMBER (number printed on the part if different from that shown on this list) and DESCRIPTION for each part ordered. When no part is assigned, order by description and rating. Also give PRICE of part (indicate if no selling).
 - (2) The CHASSIS NUMBER, is this found on a metal plate at the rear of the Chassis.

In all correspondence relating to cabinets, always mention the source code letter stamped into the upper rear rail of consoles or the bottom of table models, and the CATALOG NUMBER shown on the sticker on the back bottom or inside of cabinet.

REPAIR PARTS LIST

PART NUMBER	SCHEMATIC LOCATION	DESCRIPTION	SELLING PRICE
RESISTORS			
RC 180-1	R 9	18 Ohms 1/2 Watt 20%	\$.14
RC 390-5	R 10	39 Ohms 1/2 Watt 10%	.31
RC 222-5	R 11	2,200 Ohms 1 Watt 10%	.31
RC 183-2	R 1,2	18,000 Ohms 1/2 Watt 10%	.14
RC 224-1	R 7,8	220,000 Ohms 1/2 Watt 20%	.14
RC 334-1	R 6	330,000 Ohms 1/2 Watt 20%	.14
RC 475-1	R 4	4.7 meg ohms 1/2 Watt 20%	.14
RC 106-1	R 5	10 meg ohms 1/2 Watt 20%	.14
VC 11	R 3	2 meg ohms Volume Control, 100K Stop	1.48
CONDENSERS			
CM 100-1	C 1	10 mmf 500 Volts Mica (part of LA 8)	
CM 151-1	C 6	150 mmf 500 Volts Mica	.28
CM 501-1	C 3	500 mmf 500 Volts Mica	.22
CP 202-2	C 9	.002 mfd 400 Volts Paper	.27
CP 502-2	C 7	.005 mfd 400 Volts Paper	.27
CP 203-1	C 8	.02 mfd 400 Volts Paper	.27
CPM 203-1	C 10	.022 mfd 400 Volts Molded	.41
CP 503-1	C 4,5	.05 mfd 400 Volts Paper	.27
CE 15	C 11A,11B	2X 40 mfd 150 Volts Electrolytic	1.62
CV 14	C 2A,2B	Variable Condenser	3.30
COILS AND TRANSFORMERS			
LA 8		Antenna Coil	1.23
LC 10A		Oscillator Coil	1.05
LF 24		I. F. Transformer	2.11
CB 106-SE		Cabinet, Ebony	2.53
KN 20-2		Knob, Ivory	.11
KN 37		Large Knob, Ebony	.17
MP 9-D		Decorative Pistol	.20
MP 10-D		Cowboy and Horse	.44
BK 39		Cabinet Back	.14
HK 22		Antenna Wire Hank	.34
LD 65		Line Cord	.77
SO 17		Miniature Wafer Socket, 1 inch Mounting	.21
SO 11		Wafer Socket, 1 5/16 inch Mounting	.21
SP 47-10A		4" P. M. Speaker with Output Transformer	3.49

MODELS 1058, 1059, 1062,
1063, Ch. 101.860

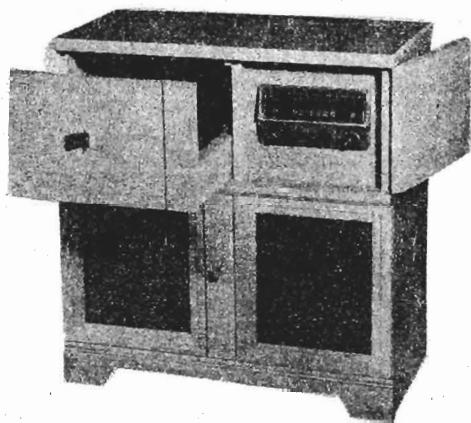

CATALOGS 1058 - MAHOGANY
1059 - BLOND OAK



CATALOGS 1062 - WALNUT
1063 - MAHOGANY

GENERAL DESCRIPTION

The 101.860 chassis is an 8 tube, 2 band, A C type, AM-FM receiver.
1058 (Mahogany) and 1059 (Blonde Oak) have a 10" electromagnet speaker.
1062 (Walnut) and 1063 (Mahogany) have a 12" electromagnet speaker.

SPECIFICATIONS

POWER SUPPLY

All models 117 volts AC, 60 cycle unless otherwise specified. Power Consumption 105 watts.

FREQUENCY RANGE

Standard Broadcast	540-1600 KC.
Frequency Modulation (FM)	88-108 MC.

ANTENNA EQUIPMENT

These models have a Silvertone built-in antenna system which will provide excellent

INTERMEDIATE FREQUENCIES

AMIF Carrier	455 KC.
FM IF Carrier	10.7 MC.

POWER OUTPUT

Undistorted	2.75 Watts
Maximum	4.50 Watts

local reception on both the AM and FM bands. For locations where an outside antenna is necessary a special Silvertone AM-FM Antenna Kit Catalog No. 6710 is available.

ALIGNMENT PROCEDURE

WARNING: No attempt should be made to adjust the alignment of this receiver without using the following equipment: Signal Generator, FM Sweep Generator, Cathode Ray Oscilloscope, Output Meter, Insulated Screw Driver.

AM ALIGNMENT

Output meter connection	Across speaker voice coil
Generator ground lead connection	Receiver chassis
Generator modulation	30% 400 cycles
Position of volume control	Fully on
Position of tone control	Fully counterclockwise
Position of FM-AM-PHO Switch	AM

MODELS 1058, 1059, 1062,
1063, Ch. 101, 860

TUNER POSITION	GENERATOR FREQUENCY	DUMMY ANTENNA	GENERATOR CONNECTION	CORE & TRIMMER ADJUSTMENTS (IN ORDER SHOWN)	CORE OR TRIMMER FUNCTION
Open	455 KC.	0.1 Mfd.	Transl-Grid	T4-A, T4-B T2-A, T2-B	I. F.
1650 KC.	1650 KC.	50 Mmfd.	Ext. Ant.	C11	Osc.
1400 KC.	1400 KC.	50 Mmfd.	Ext. Ant.	C 5	Ant.

FM IF ALIGNMENT

Sweep generator frequency _____ 10.7 MC.
 Sweep generator deviation _____ 300 KC.
 Dummy antenna _____ 0.1 Mfd.
 Sweep generator ground lead connection _____ Receiver chassis
 Position of tuner _____ Open
 Position of volume control _____ Fully on
 Position of tone control _____ Fully counterclockwise
 Position of FM-AM-PHO switch _____ FM

Make shielded probe shown in Figure 1 for use with Oscilloscope where indicated below.

GENERATOR CONNECTION	OSCILLOSCOPE CONNECTION	CORE ADJUSTMENTS	ADJUST FOR CURVE IN	CORE FUNCTION
FM - First IF grid	Probe - across T5 - Primary	T3-A, T3-B	Figure 2	IF
Trans-Grid	Probe - across T5 - Primary	T1-A, T1-B	Figure 2	IF IF
FM - Second IF grid	Across C35	T5-A, T5-B	Figure 3	Disc.

FM RF ALIGNMENT

Output meter connection _____ Across speaker voice coil
 Sweep generator deviation _____ 22.5 KC.
 Dummy antenna _____ Two 120 ohm resistors
 Sweep generator connection _____ FM antenna board
 Position of volume control _____ Fully on
 Position of tone control _____ Fully counterclockwise
 Position of FM-AM-PHO switch _____ FM

POSITION OF TUNER	GENERATOR FREQUENCY	TRIMMER & COIL ADJUSTMENT	TRIMMER OR COIL FUNCTION
Open	108.5 MC.	C10	Osc.
108MC.	108.0 MC.	C 9	Transl.
Closed	88.5 MC.	L 4	Osc.
88 MC.	88.0 MC.	L 3	Transl.

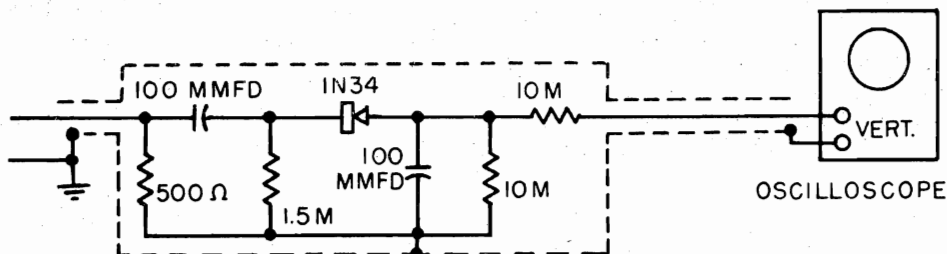

MODELS 1058, 1059, 1062,
1063, Ch. 101.860

FIG. 1 - SHIELDED PROBE FOR FM I. F. ALIGNMENT

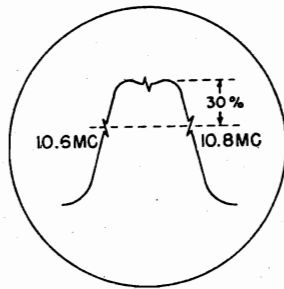

FIG. 2 - FM I. F. RESPONSE

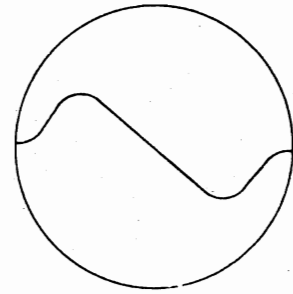

FIG. 3 - FM DISCRIMINATOR OUTPUT

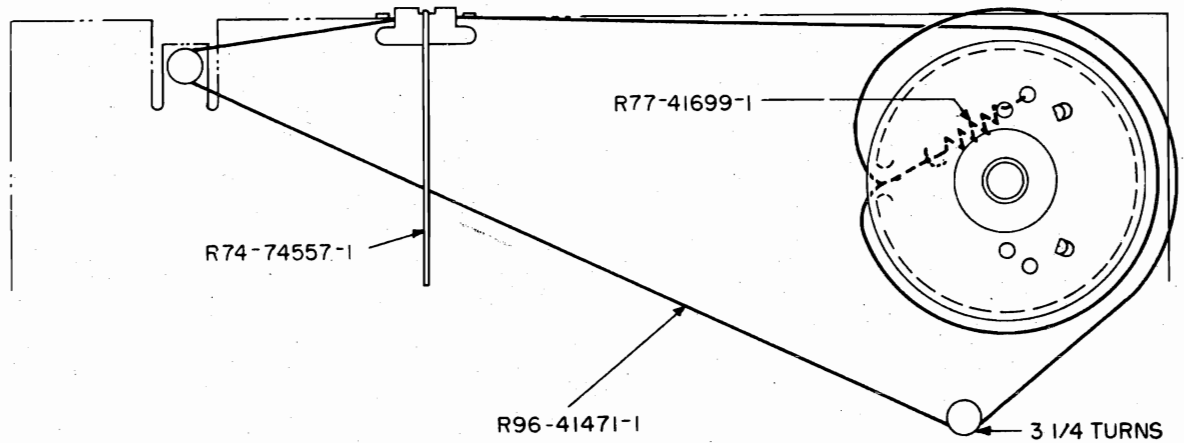

FIG. 4 - STRING AND POINTER HOOKUP

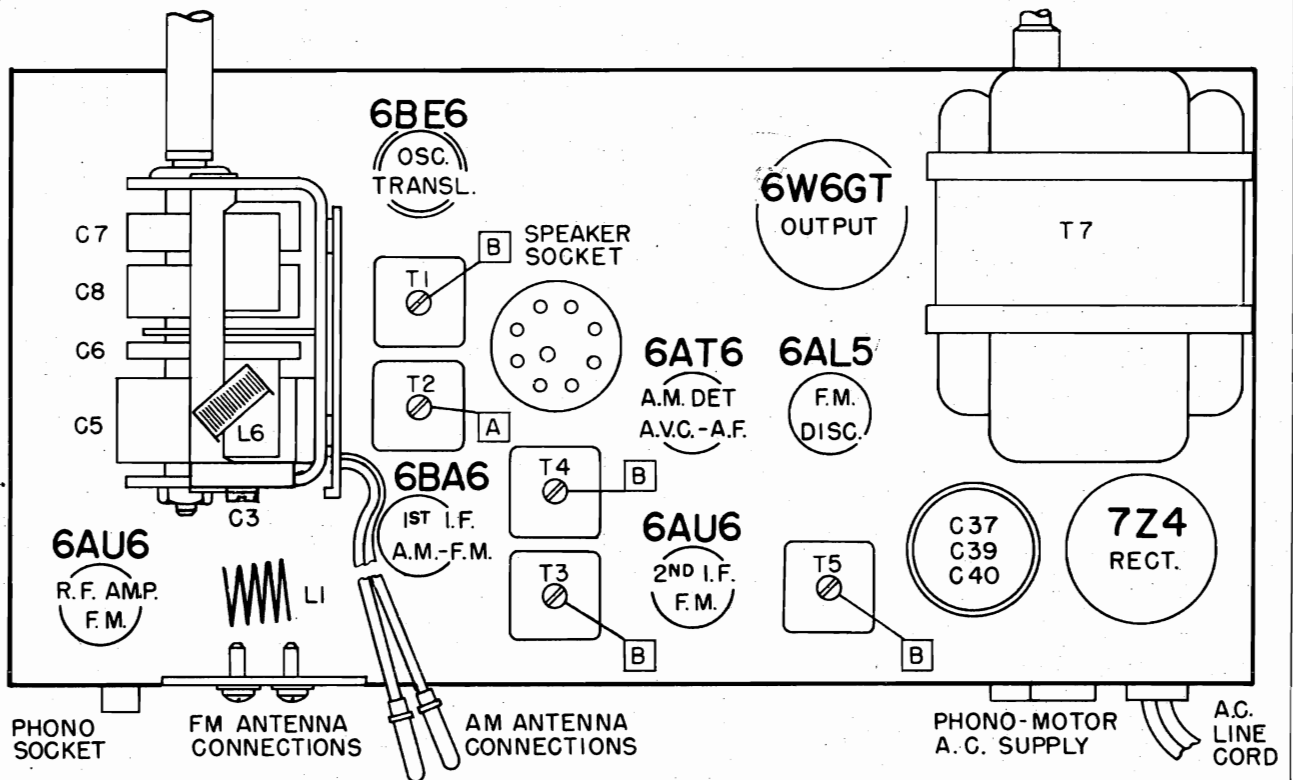
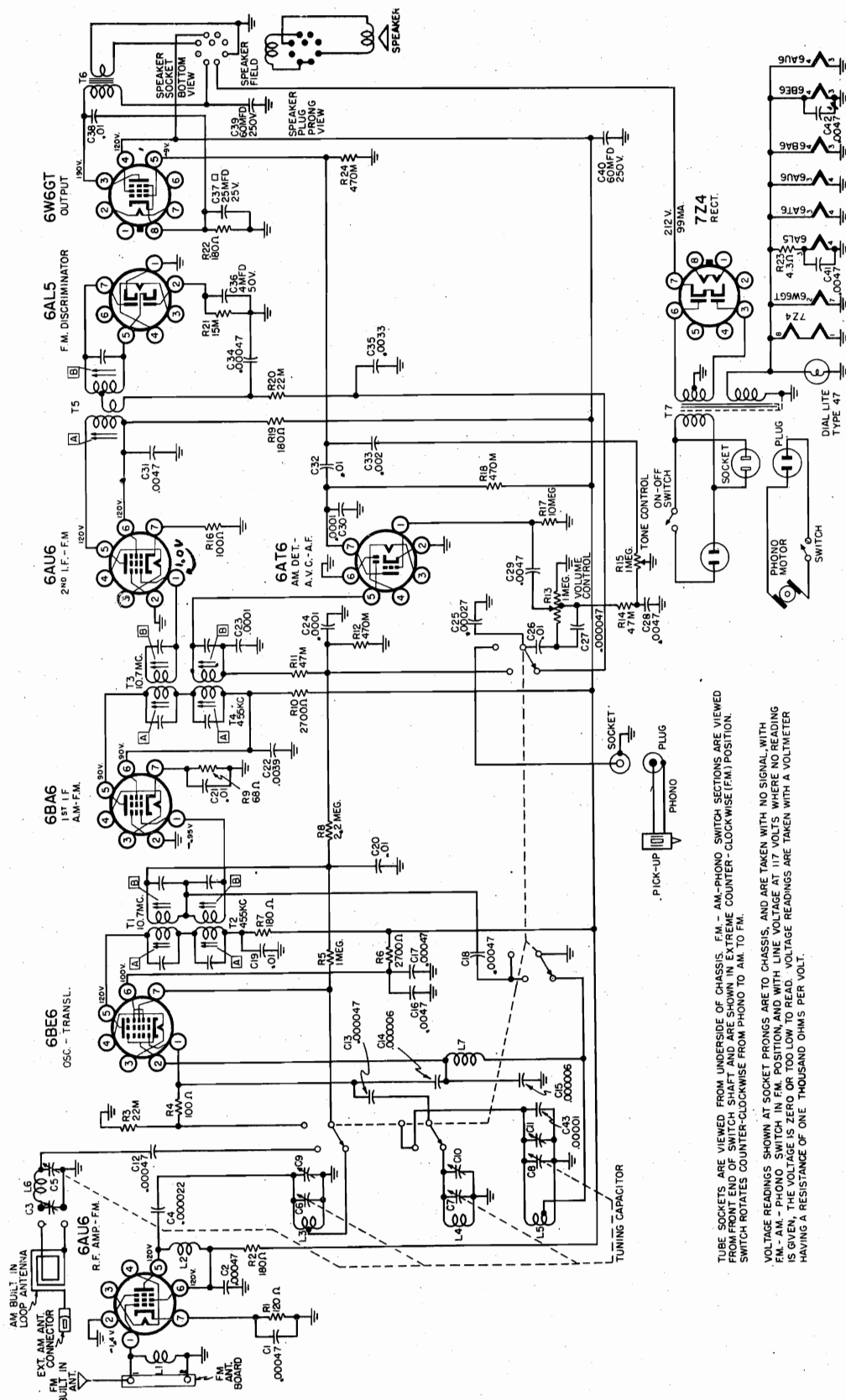

FIG. 5 - RADIO CHASSIS LAYOUT - TOP VIEW

MODELS 1058, 1059, 1062,
1063, Ch. 101.860



TUBE SOCKETS ARE VIEWED FROM UNDERSIDE OF CHASSIS. F.M. - AM-PHONO SWITCH SECTIONS ARE VIEWED FROM FRONT END OF SWITCH SHAFT AND ARE SHOWN IN EXTREME COUNTER-CLOCKWISE (F.M.) POSITION. SWITCH ROTATES COUNTER-CLOCKWISE FROM PHONO TO AM. TO F.M.

VOLTAGE READINGS SHOWN AT SOCKET PRONGS ARE TO CHASSIS, AND ARE TAKEN WITH NO SIGNAL, WITH F.M. PHONO SWITCH IN F.M. POSITION AND WITH LINE VOLTAGE AT 117 VOLTS. WHERE NO READING IS GIVEN, THE VOLTAGE IS ZERO OR TOO LOW TO READ. VOLTAGE READINGS ARE TAKEN WITH A VOLTMETER HAVING A RESISTANCE OF ONE THOUSAND OHMS PER VOLT.

SCHEMATIC DIAGRAM FOR 101.860 RADIO CHASSIS

MODELS 1058, 1059, 1062,
1063, Ch. 101.860

FIG. 6 - RADIO CHASSIS LAYOUT - BOTTOM VIEW

HOW TO ORDER PARTS

1. Use Correct Order Form.
2. On the Purchase Order always give the following information:
 - (1) **PART NUMBER** (number printed on the part if different from that shown in this list) and **DESCRIPTION** for each part ordered. When no part number is assigned, order by description and rating. Also give **PRICE** of part (indicate if no selling).
 - (2) The **CHASSIS NUMBER**, which is 101.860. This number is found on a metal plate at the rear of the chassis.

In all correspondence relating to cabinets, always mention the source code letter stamped into the upper rear rail of consoles or on the bottom of table models, and the Catalog Number shown on the sticker on the back, bottom or inside of the cabinet.

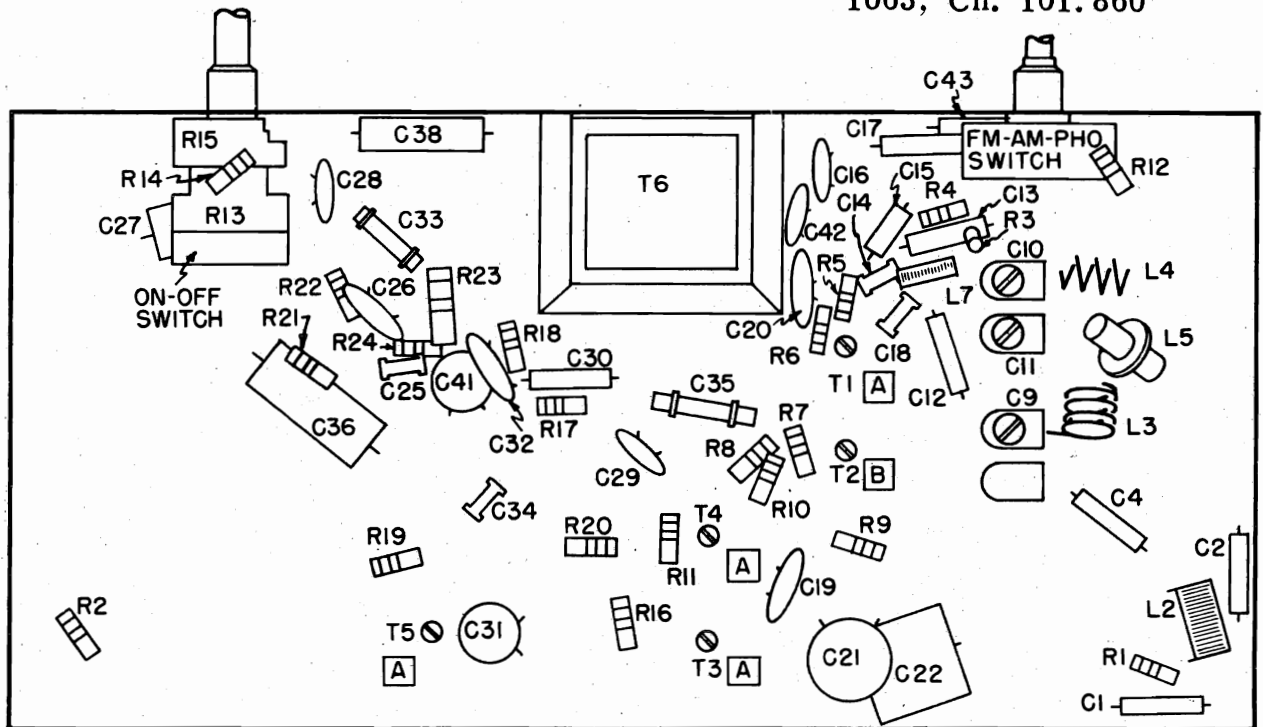
REPAIR PARTS LIST

<u>SCHEMATIC LOCATION</u>	<u>PART NUMBER</u>	<u>DESCRIPTION</u>	<u>SELLING PRICE EA.</u>
	R85-61164-1	Adapter - Record	\$.03
	R81-66167-1	Arm - Stop Assembly (1062, 1063)	.43
	R74-74742-1	Background - Dial	.46
	R73-74597-1	Board - Antenna - FM	.20
	R71-66224-1	Bushing - Line Cord	.06
	R86-74751-1	Bushing - Rubber	.06
	R71-65538-1	Button - Snap	.01
C38	R45-641032-1	Capacitor - .01 Mfd. - 400 V. - Molded Paper	.23
C14, C15	R43-74592-2	Capacitor - 6.0 Mmfd. - Ceramic	.29
C43	R43-74592-3	Capacitor - 10.0 Mmfd. - Ceramic	.29
C25	R43-602710-20	Capacitor - 270 Mmfd. - Ceramic	.20
C18, C34	R43-604710-20	Capacitor - 470 Mmfd. - Ceramic	.20
C33	R43-602020-36	Capacitor - .002 Mfd. - Ceramic	.23
C35	R43-603329-33	Capacitor - .0033 Mfd. - Ceramic	.29
C16, C28, C29, C31, C41, C42	R43-704726-62	Capacitor - .0047 Mfd. - Ceramic	.20
C19, C20, C21, C26, C32	R43-701036-63	Capacitor - .01 Mfd. - Ceramic	.23

MODELS 1058, 1059, 1062,
1063, Ch. 101.860

REPAIR PARTS LIST (cont'd)

<u>SCHEMATIC LOCATION</u>	<u>PART NUMBER</u>	<u>DESCRIPTION</u>	<u>SELLING PRICE EA</u>
C4	R44-452202-20	Capacitor - 22 Mmfd. - Mica	.17
C13, C27	R44-454701-20	Capacitor - 47 Mmfd. - Mica	.17
C23, C24, C30	R44-351012-20	Capacitor - 100 Mmfd. - Mica	.17
C1, C2, C12, C17	R44-454712-20	Capacitor - 470 Mmfd. - Mica	.23
C22	R44-353921-30	Capacitor - .0039 Mfd. - Mica	.63
C36	R41-69193-1	Capacitor - Electrolytic 4 Mfd. - 50 V.	.83
	R41-74576-1	Capacitor - Electrolytic 60 Mfd. - 250 V.	2.85
C39		60 Mfd. - 250 V.	
C40		60 Mfd. - 250 V.	
C37		25 Mfd. - 25 V.	
C3	R42-61629-1	Capacitor - Trimmer - Loop	.26
	R42-74596-1	Capacitor - Variable - 4 Gang	3.75
	R71-67326-1	Clip - Transformer Mounting	.01
	R71-17319-1	Clip - Tuning Shaft Retaining	.02
L6	R50-74626-1	Coil - AM Antenna	.11
L5	R50-66184-1	Coil - AM Oscillator	1.05
L1	R50-74586-1	Coil - FM Antenna	.09
L4	R50-74588-1	Coil - FM Oscillator	\$.06
L7	R50-74589-1	Coil - FM Oscillator - Cathode Choke	.11
L2	R50-74626-1	Coil - FM RF - Plate Choke	.11
L3	R50-74591-1	Coil Assembly - FM RF Grid	.23
	R37-74577-1	Control - Dual Volume & On-Off Tone	2.17
R13			
R15			
	R19-74593-1	Cord - Line	.71
	R74-74746-1	Dial - Station - Lucite	.83
	R74-74555-1	Escutcheon	2.85
	R71-47266-1	Grommet	.03
	R74-74753-1	Knob - Function	.17
	R74-74752-1	Knob - ON-OFF & Volume	.17
	R74-67965-2	Knob - Outer	.23
	R30-20963-1	Lamp - Mazda #47	.15
	R05-72417-1	Leaflet - Instruction	.14
	R27-74729-1	Loop - Antenna - AM	2.17
	R74-74802-1	Nameplate	.20
	R73-67023-1	Plug - 2 Prong - Female	.26
	R74-74557-1	Pointer - Dial	.14
	R80-67187-1	Pulley	.03
R23	R36-67223-1	Resistor - 4.3 Ohm - 1/2 W.	.06
R9	R35-336801-1	Resistor - 68 Ohm - 1/2 W.	.15
R4, R16	R35-331011-1	Resistor - 100 Ohm - 1/2 W.	.15
R1	R35-331211-1	Resistor - 120 Ohm - 1/2 W.	.15
R2, R7, R19	R35-331811-1	Resistor - 180 Ohm - 1/2 W.	.15
R6, R10	R35-332721-1	Resistor - 2,700 Ohm - 1/2 W.	.15
R21	R35-331531-1	Resistor - 15,000 Ohm - 1/2 W.	.15
R3, R20	R35-332231-1	Resistor - 22,000 Ohm - 1/2 W.	.15
R11, R14	R35-334731-1	Resistor - 47,000 Ohm - 1/2 W.	.15
R12, R18, R24	R35-334741-1	Resistor - 470,000 Ohm - 1/2 W.	.15
R5	R35-331051-1	Resistor - 1 Megohm - 1/2 W.	.15
R8	R35-332251-1	Resistor - 2.2 Megohm - 1/2 W.	.15
R17	R35-331061-1	Resistor - 10 Megohm - 1/2 W.	.15
R22	R35-431811-1	Resistor - 180 Ohm - 1 W.	.21
	R71-66225-1	Retainer - Line Cord	.06
	R81-74553-1	Shaft - Tuning	.40
	R81-67091-1	Shield - Tube - Miniature	.09
	R73-44897-1	Socket - 1 Prong	.08

MODELS 1058, 1059, 1062,
1063, Ch. 101.860

REPAIR PARTS LIST (cont'd)

<u>SCHEMATIC LOCATION</u>	<u>PART NUMBER</u>	<u>DESCRIPTION</u>	<u>SELLING PRICE EA.</u>
	R73-74598-1	Socket - 8 Prong	.23
	R72-73227-1	Socket - Tube - 7 Prong - Miniature	.17
	R72-73227-2	Socket - Tube - 7 Prong - Miniature	.17
	R72-74694-1	Socket - Pilot Lamp	.31
	R72-61013-1	Socket - Tube - 8 Prong - Lock-in - Molded	.20
	R72-41542-1	Socket - Tube - 8 Prong - Octal	.13
	R12-74757-1	Speaker - 10" EM (1058, 1059)	8.77
	R73-64567-1	Plug - 8 Prong	.14
	R12-74762-1	Speaker - 12" EM (1062, 1063)	8.31
	R73-64567-1	Plug - 8 Prong	.14
	R77-41699-1	Spring - Drive String Tension	.06
	R77-66164-1	Spring - Tension - Stop Arm Actuating (1062, 1063)	.23
	R86-66173-1	Stop - Rubber (1062, 1063)	.01
	R96-41471-1	String - Drive (35')	.02
	R71-74763-1	Stud - Stop Arm Mounting (1062, 1063)	.17
	R33-74578-1	Switch - FM, AM, PHO	1.45
T2	R57-74580-1	Transformer - IF #1 - AM	1.97
T4	R57-74582-1	Transformer - IF #2 - AM	2.08
T1	R57-74579-1	Transformer - IF #1 - FM	1.57
T3	R57-74581-1	Transformer - IF #2 - FM	1.57
T5	R57-74583-1	Transformer - Discriminator - FM	1.68
T6	R56-74584-1	Transformer - Output	2.25
T7	R55-74585-1	Transformer - Power	5.00

SUPPLEMENT NO.1

Chassis 456.860-1 is the same as chassis 101.860 except that permanent magnet type speakers are used instead of electromagnetic types and the output circuit is revised accordingly.

Except for the Repair Parts listed below and the schematic diagram refer to 101.860 for all Service Information, Repair Parts, and Ordering Instructions.

<u>SCHEMATIC LOCATION</u>	<u>PART NUMBER</u>	<u>DESCRIPTION</u>	<u>SELLING PRICE EACH</u>	<u>MU CODE</u>
C38	R45-642032-1	Capacitor - .02 Mfd. - 400 V.	\$.23	
R21	R35-332232-1	Resistor - 22,000 Ohm - 1/2 W.	.06	
R25	R36-62773-2	Resistor - 1,850 Ohm - 5 W.	.50	
	R12-74104-4	Speaker - 10" PM (1058, 1059)	5.50	B5
	R12-73651-4	Speaker - 12" PM (1062, 1063)	7.55	B5
T6	R56-74936-1	Transformer - Output	2.46	

MODELS 1058, 1059, 1062,
1063, Ch. 456.860-1

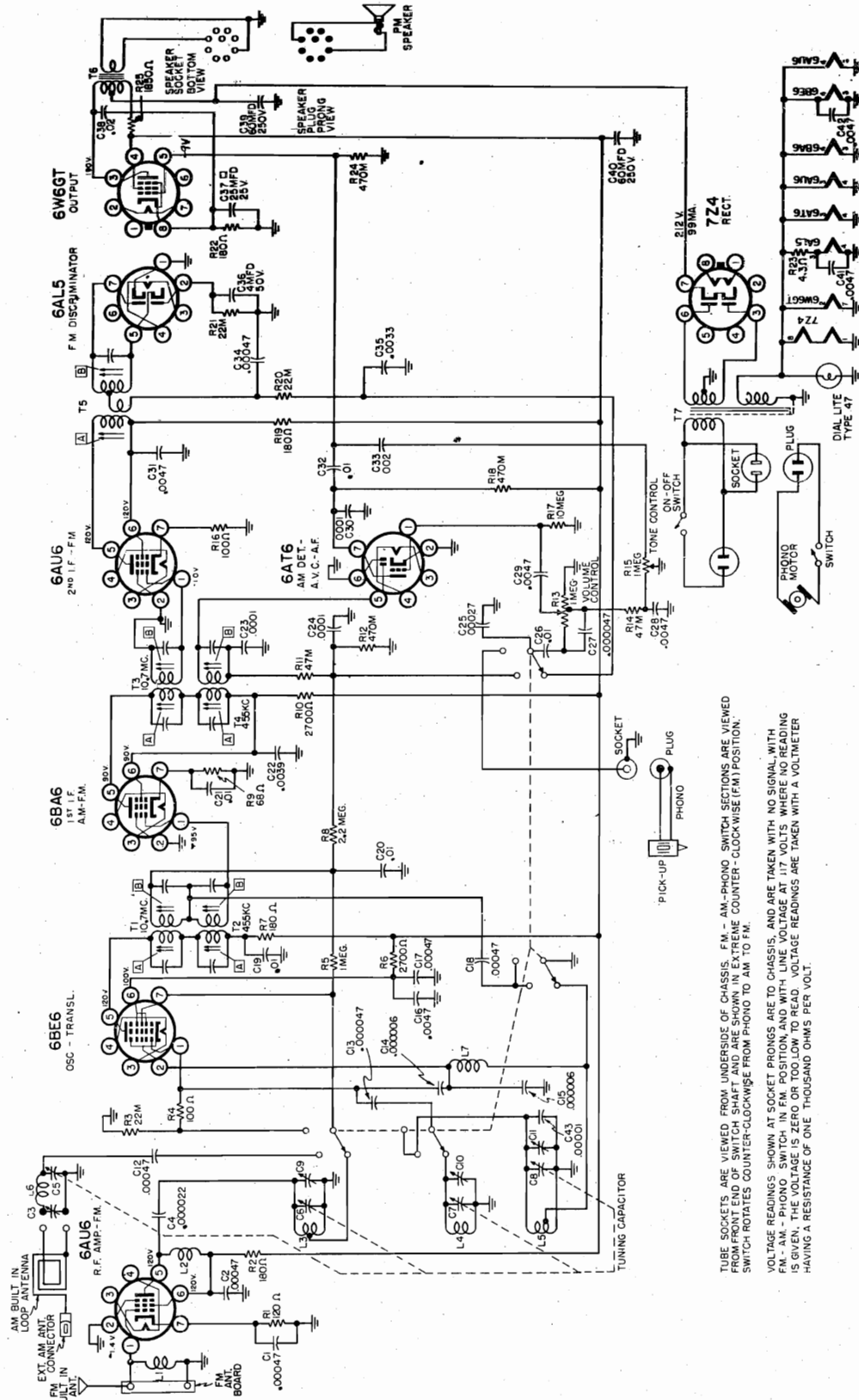

TUBE SOCKETS ARE VIEWED FROM UNDERSIDE OF CHASSIS. FM - AM-PHONO SWITCH SECTIONS ARE VIEWED FROM FRONT END OF CHASSIS. EXTREME POSITION - COUNTER-CLOCKWISE (FM) POSITION. SWITCH ROTATES COUNTER-CLOCKWISE FROM PHONO TO AM TO FM.
VOLTAGE READINGS SHOWN AT SOCKET PRONGS ARE TO CHASSIS, AND ARE TAKEN WITH NO SIGNAL WITH FM - AM - PHONO SWITCH IN FM POSITION, AND WITH LINE VOLTAGE AT 117 VOLTS. WHERE NO READING IS GIVEN, THE VOLTAGE IS ZERO OR TOO LOW TO READ. VOLTAGE READINGS ARE TAKEN WITH A VOLTMETER HAVING A RESISTANCE OF ONE THOUSAND OHMS PER VOLT.

SCHEMATIC DIAGRAM FOR 456.860-1 RADIO CHASSIS

Chassis 101.860-1 is the same as chassis 101.860 except that permanent magnet type speakers are used instead of electromagnetic types and the output circuit is revised accordingly.

Except for the Repair Parts listed below and the schematic diagram on page below refer to Ch. 101.860 for all Service Information, Repair Parts, and Ordering Instructions.

SUPPLEMENT 2		SUPPLEMENT 3	
SCHEMATIC LOCATION	PART NUMBER	SCHEMATIC LOCATION	PART NUMBER
DESCRIPTION		DESCRIPTION	
C38	R45-642032-1	C38	R45-662232-1
R21	R35-332322-1	R05-72570-1	Capacitor - .022 Mfd. - 600 V.
R25	R36-62773-2	R27-77452-1	Leaflet - Instruction
T6	R12-74104-4	R35-332231-1	Loop and Back Cover
	R56-74936-1	R36-62773-2	Resistor - 22,000 Ohm - 1/2 W.
		R12-74104-5	Resistor - 1,850 Ohm - 5 W.
		R56-74936-1	Speaker - 10" PM (2063, 2064)
			Transformer - Output

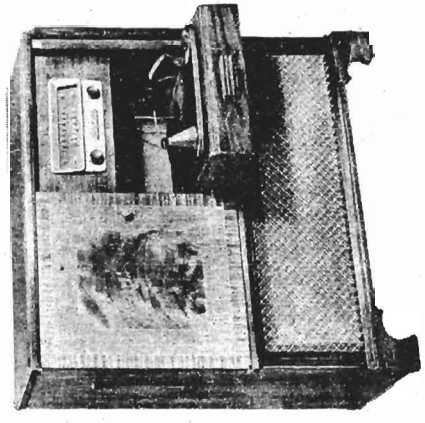
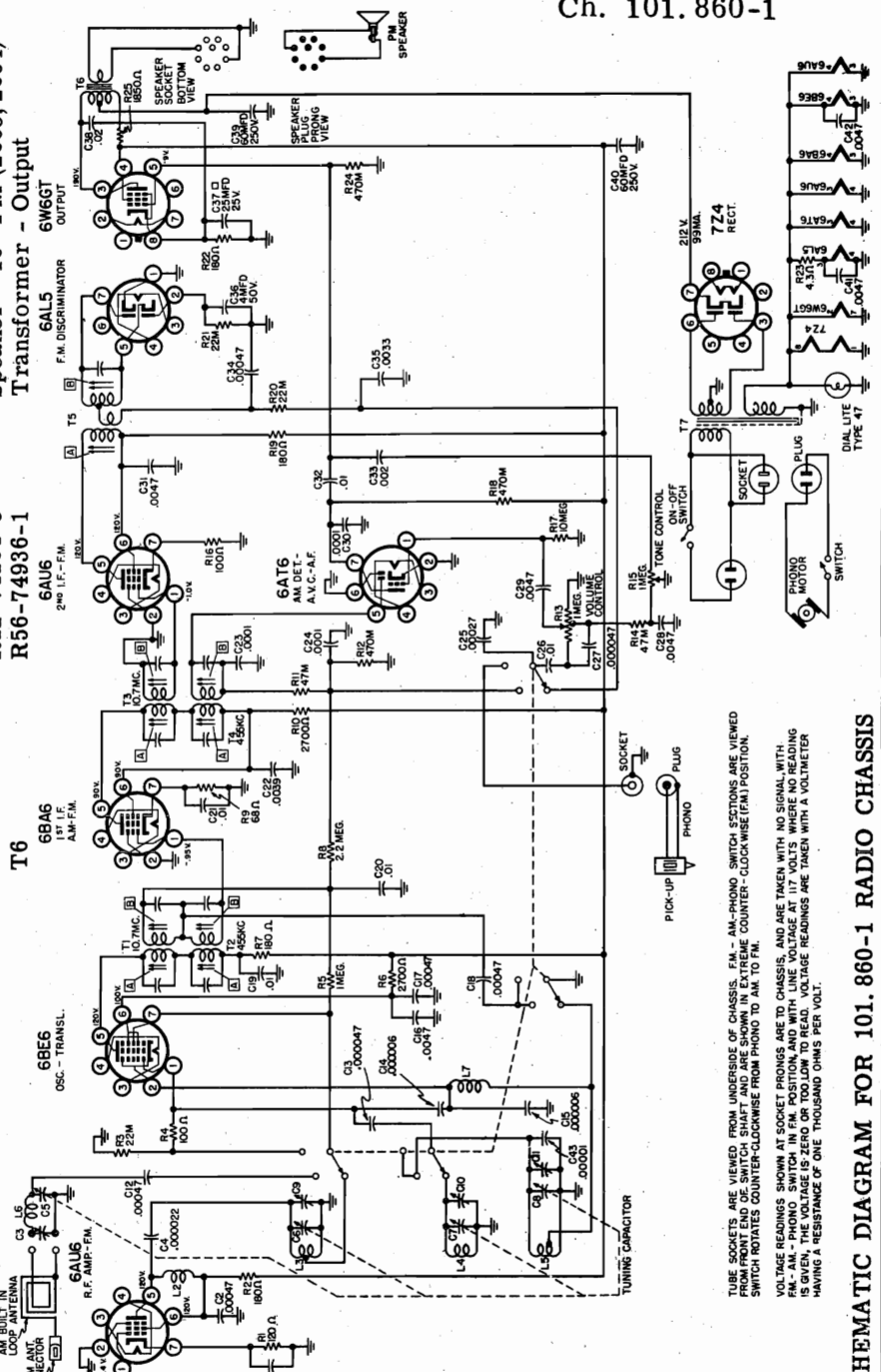

TUBE SOCKETS ARE VIEWED FROM UNDERSIDE OF CHASSIS. F.M. - AM-PHONO SWITCH SECTIONS ARE VIEWED FROM FRONT END OF SWITCH SHIFTER AND ARE SHOWN IN EXTREME COUNTER-CLOCKWISE (FM) POSITION. SWITCH ROTATES COUNTER-CLOCKWISE FROM PHONO TO AM TO FM.

VOLTAGE READINGS SHOWN AT SOCKET PRONGS ARE TO CHASSIS, AND ARE TAKEN WITH NO SIGNAL WITH FM - AM - PHONO SWITCH IN FM POSITION, AND WITH LINE VOLTAGE AT 117 VOLTS WHERE NO READING IS GIVEN. THE VOLTAGE IS ZERO OR TOO LOW TO BEAR. VOLTAGE READINGS ARE TAKEN WITH A VOLTMETER HAVING A RESISTANCE OF ONE THOUSAND OHMS PER VOL.

2063 - MAHOGANY
2064 - BLONDE

SCHEMATIC DIAGRAM FOR 101.860-1 RADIO CHASSIS

MODELS 13, 14,
Ch. 478.239**SPECIFICATIONS**

Power Supply
117 Volts D.C., or 117 Volts, 50-60 Cycles A.C.
Frequency Range 532.5 to 1620 kc.
Intermediate Frequency 455 kc.
Tuning Two gang capacitor
Speaker 4 inch PM, 3.2 ohm voice coil impedance
Power Consumption 30 Watts
Power Output 1 watt undistorted, 1.5 watt maximum
Sensitivity 200 uv/m at 50 milliwatts output
Selectivity 45kc. broad at 1000 times signal at 1000kc.

TUBE COMPLEMENT

12BE6 Mixer and Oscillator
12BA6 I.F. Amplifier
12AT6 Detector, A.V.C. and 1st Audio
50C5 Audio Output
35W4 Power Rectifier

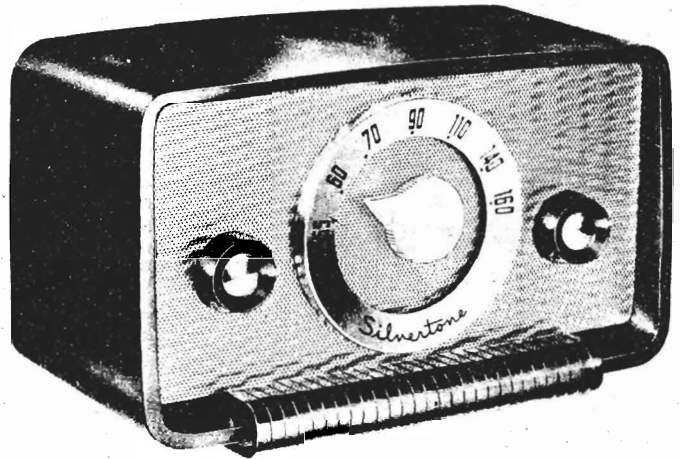
**ALIGNMENT PROCEDURE****PRELIMINARY:**

Output meter connection across 3.2 ohm speaker voice coil
Output meter reading to indicate 50 MW across speaker voice coil 0.4 volts
Generator modulation 30%, 400 cycles
Position of volume control maximum (fully clockwise)
Position of pointer with rotor full open (plates out of mesh) . . . slightly below 160 Kc calibration mark on the cabinet dial (pointer horizontal to right)

	Position of Variable	SIGNAL GENERATOR				Trimmer Adjustments (in order shown) for maximum output
		Frequency	Dummy Antenna	Connection to Receiver	Ground Connection	
IF	Rotor full open (plates out of mesh)	455 Kc	.05 Mfd.	Grid of 12BE6 (pin 7)	Chassis	Input & output trimmers on IF cans A3 A4 A5 A6
RF	Rotor full open (plates out of mesh)	1620 Kc		*Test Loop	*Test Loop	Oscillator Trimmer A2
	1400 Kc	1400 Kc		*Test Loop	*Test Loop	Antenna Trimmer A1
	600 Kc	600 Kc		*Test Loop	*Test Loop	(Check Point)**

*Connect generator lead to Hazeltine Test Loop, Model 1150, placed two feet from the set loop, or three turns of wire about six inches in diameter, placed about one foot from the set loop.

**With a generator signal of 600 Kc, turn the set to the point where maximum output is obtained, which should be approximately 600 Kc on the dial. Adjust antenna section plates of variable for maximum

output.

The alignment procedure should be done in the order given for greatest accuracy. Align for maximum output. Reduce input to keep output near 0.4 volts.

Always keep the output from the generator at its lowest possible value to prevent the AVC of the receiver from interfering with accurate alignment.

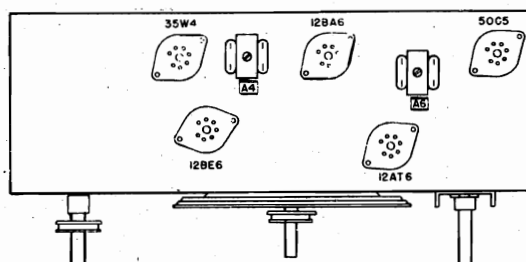

BOTTOM VIEW OF CHASSIS

632 AUGUST 16, 1951

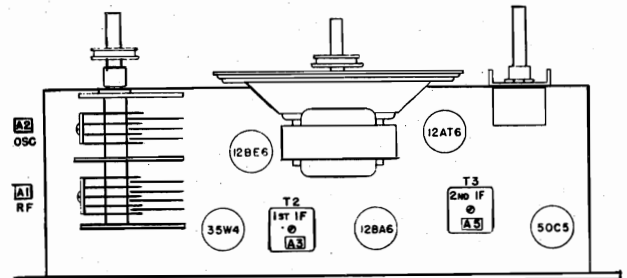

TOP VIEW OF CHASSIS

MODELS 13, 14,
Ch. 478.239

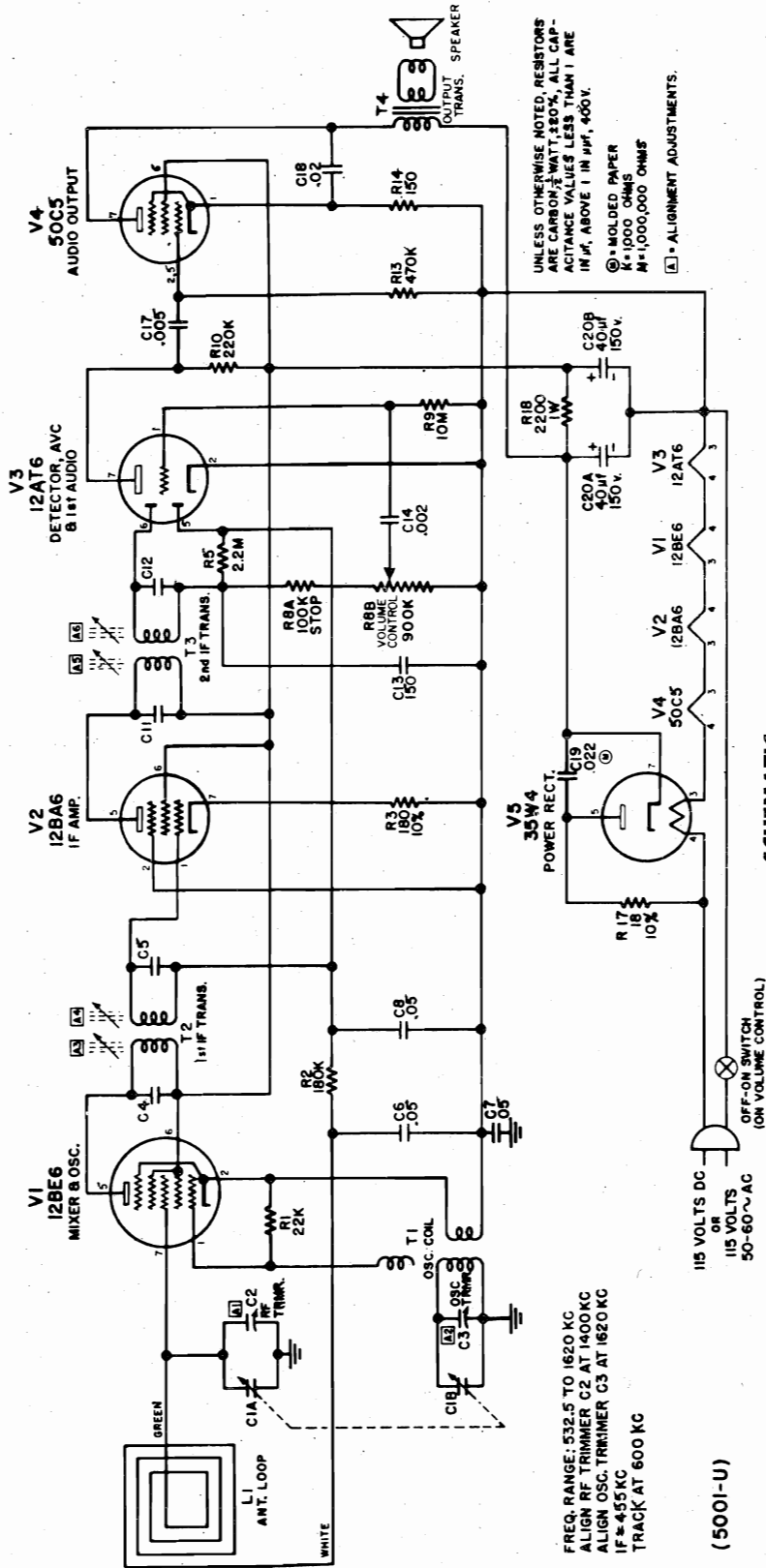

SCHEMATIC
478.239 CHASSIS

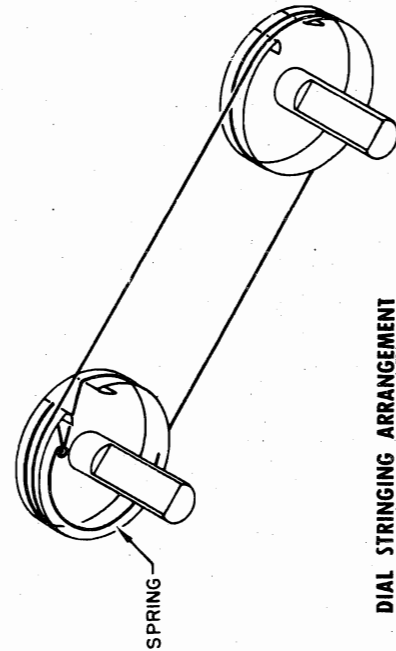

HOW TO ORDER PARTS

1— Use Correct Order Form.

2— On the Purchase Order always give the following information:

- (1) **PART NUMBER** (number printed on the part if different from that shown on this list) and **DESCRIPTION** for each part ordered. When no part is assigned, order by description and rating. Also give **PRICE** of part (indicate if no selling).
- (2) The **CHASSIS NUMBER**, which is 478.239. This number is found on a metal plate at the rear of the chassis.

SCHEMATIC LOCATION	PART NO.	DESCRIPTION	SELLING PRICE
RESISTORS			
(Carbon, 1/2 Watt + 20% Unless Otherwise Specified)			
R 17	RC-180-2	18 Ohms 1/2 Watt 10%	.14
R 14	RC-151-1	150 Ohms 1/2 Watt	.14
R 3	RC-181-2	180 Ohms 1/2 Watt 10%	.14
R 18	RC-222-4	2,200 Ohms 1 Watt	.31
R 1	RC-223-1	22,000 Ohms 1/2 Watt	.14
R 2	RC-184-1	180,000 Ohms 1/2 Watt	.14
R 10	RC-224-1	220,000 Ohms 1/2 Watt	.14
R 13	RC-474-1	470,000 Ohms 1/2 Watt	.14
R 5	RC-225-1	2.2 Megohms 1/2 Watt	.14
R 9	RC-106-1	10 Megohms 1/2 Watt	.14
R 8A,8B	VC-21	Off-On Switch and Vol. Control 1 Megohm with 100 K stop	1.65
CONDENSERS			
C 13	CM-151-1	150 mmfd Mica	.29
C 14	CP-202-1	.002 mfd Paper	.29
C 17	CP-502-2	.005 mfd Paper	.26
C 18	CP-203-1	.02 mfd Paper	.26
C 19	CPM-203-1	.022 mfd Molded Paper	.40
C 6,7,8	CP-503-1	.05 mfd Paper	.26
C 20A,20B	CE-15	2x40 mfd 150 Volts Electrolytic	1.62
C 1A,1B	CV-22	Variable Condenser	2.70
C 2,3		Trimmers (part of C 1A,1B)	
C 4,5		(part of T 2)	
C 11,12		(part of T 3)	
COILS & TRANSFORMERS			
T 2,3	LF-29	I. F. Transformers	1.94
T 1	LC-20-D	Oscillator Coil	.88
L 1	LP-12	Loop Antenna	2.31
CABINET, HARDWARE & ACCESSORIES			
	CB-122-M	Cabinet, Mahogany (Model 13) or	3.35
	CB-122-I	Cabinet, Ivory (Model 14)	3.35
	KN-33-3	Knobs, Mahogany (Model 13)	.54
	KN-33-2	or Knobs, Ivory (Model 14)	.54
	KN-32-2	Pointer Knob, Ivory	.34
	MS-124	Pointer Shaft Mounting Bracket	.14
	GR-38	Decorative Grille	2.31
	BF-19	Baffle	.20
	MS-141-D	Dial Ring	1.03
	SG-7	Dial Spring	.09
	CR-2	Drive Cord	.09
	SP-47-22	4" PM Speaker with output transformer, or	4.60
	SP-47-22A	4" PM Speaker with output transformer	4.60
	LD-65	Line Cord	.77
	IB-36-1-D	Customer Instruction Book	.15

MODELS 25, 27,
Ch. 478. 238

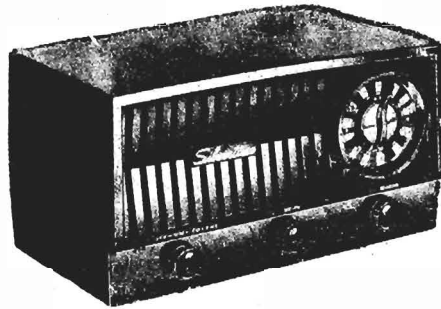

SPECIFICATIONS

Power Output

Undistorted—1.25 watts
Maximum—2.25 watts

Sensitivity

AM—250 uv/m average } for 50 MW output
FM—50 uv average }

Selectivity

AM—49.5 Kc. broad at 1000 times signal at 455 Kc.
FM—810 Kc. broad at 1000 times signal at 10.7 Mc.

TUBE COMPLEMENT

- V1 6BJ6 —FM RF Amplifier
- V2 12AT7—FM Mixer and Oscillator
- V3 6BJ6 —AM-FM IF Amplifier
- V4 12BA6—FM IF Amplifier
- V5 19T8 —Ratio Detector, AM Detector and First Audio
- V6 12BE6—AM Mixer and Oscillator
- V7 35C5 —Audio Output

Power Supply

105-125 V. D.C.
or 105-125 V., 50-60 cycles A.C.

Frequency Range

AM—530 Kc. to 1630 Kc.
FM— 87 Mc. to 109 Mc.

Intermediate Frequency

AM—455 Kc.
FM—10.7 Mc.

Antenna

AM—Loop
FM—External hank

Tuning

Clock dial, 4 section ganged variable

Speaker

4 inch Permanent Magnet type
Voice Coil impedance 3.2 ohms

Power

35 watts at 117 volt line

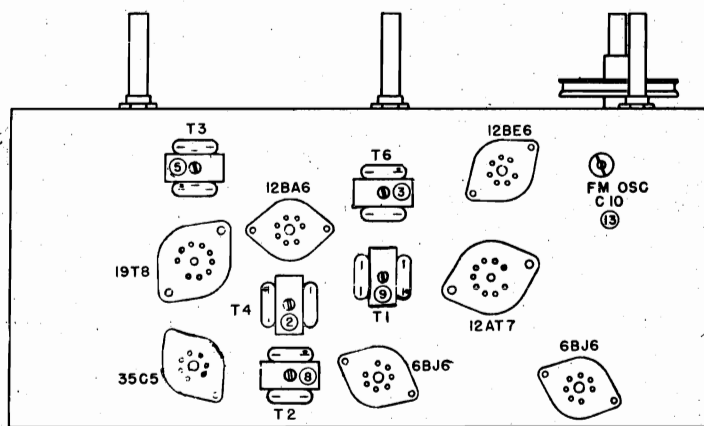

FIG. 2 — BOTTOM VIEW OF CHASSIS

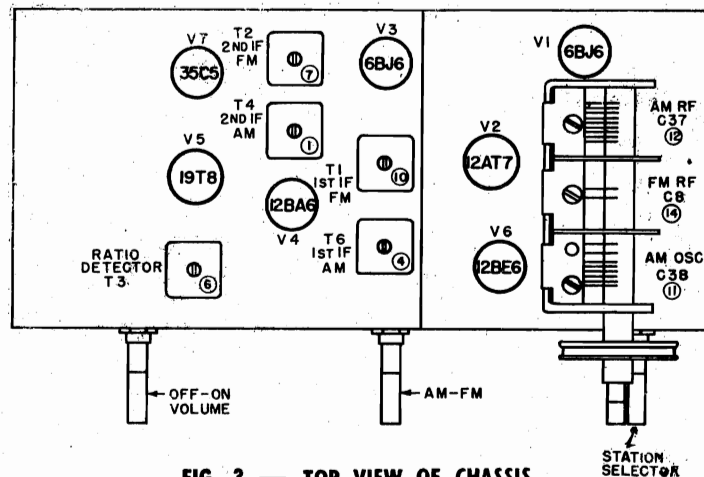

FIG. 3 — TOP VIEW OF CHASSIS

MODELS 25, 27,
Ch. 478. 238

ALIGNMENT PROCEDURE

PRELIMINARY —	Output meter connection	Across speaker voice coil
	Output meter reading to indicate 500 MW (Standard Output)	1.27 volt
	Generator modulation	30%—400 cycles
	Position of volume control	Fully clockwise
	Set Dial Pointer	Horizontal, variable condenser closed
	Set band switch	To left for AM alignment; to right for FM alignment

AM ALIGNMENT

POSITION OF VARIABLE	GENERATOR FREQUENCY	DUMMY ANTENNA	GENERATOR CONNECTION HIGH SIDE	GENERATOR CONNECTION GROUND LEAD	ADJUST TRIMMERS IN ORDER SHOWN FOR MAX. OUTPUT	TRIMMER FUNCTION
Open	455 Kc	.05 Mfd	Mixer grid	Chassis	① ② ③ ④	I. F.
1620 Kc	1620 Kc		*Test loop	Test loop	⑪	Oscillator
1400 Kc	1400 Kc		*Test loop	Test loop	⑫	Antenna
**600 Kc	600 Kc		*Test loop	Test loop	Check point	Antenna

*Connect generator lead to a Standard Hazeltine Test Loop, Model 1150, placed two feet from the set loop, or three turns of wire about six inches in diameter, placed about one foot from the set loop.

**With a generator signal of 600 Kc, tune the set to the point where maximum output is obtained, which should be approximately 600 Kc on the dial. Adjust antenna section plates of variable for maximum output.

The alignment procedure should be repeated in the original order for greatest accuracy. Align for maximum output.

Always keep the output from the signal generator at its lowest possible value to make the A. V. C. action of the receiver ineffective.

FM ALIGNMENT

- 1—Connect two 100,000 ohm ($\pm 5\%$) resistors in series across R22.
- 2—Connect minus lead from voltmeter to pin 2 of the 19T8 (V5); plus lead to chassis.
- 3—Set FM generator to 10.7 Mc and connect high side through a .01 Mfd. condenser to pin 1 of the 12BA6 (V4); low side to chassis (Fig. 5).
- 4—Adjust ⑤ for maximum voltage.
- 5—Place minus lead of voltmeter at the junction of the two 100,000 ohm resistors in series across R22 used in step 1; plus lead to high side of Volume Control, R28 (Fig. 6).
- 6—Adjust ⑥ for zero reading. A positive or negative reading will be obtained on either side of the correct setting.
- 7—Connect high side of generator to mixer coil (L3), low side of generator to chassis.
- 8—Short A.V.C. to chassis at junction of R21 and R9.
- 9—Disconnect negative lead of electrolytic condenser C47 (Fig. 7).
- 10—Connect vertical input of scope across R22. (Grounded terminal to chassis, ungrounded terminal to high side of R22.)
- 11—Adjust ⑦, ⑧, ⑨ and ⑩ for greatest vertical sweep of pattern. Stagger tune so that pattern is as shown in Fig. 8.
- 12—After alignment is completed resolder negative lead of electrolytic condenser C47.

DETECTOR AND IF ALIGNMENT USING SIGNAL GENERATOR AND OSCILLOSCOPE

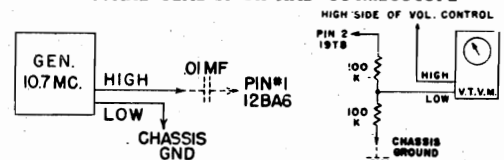

FIG. 5

FIG. 6

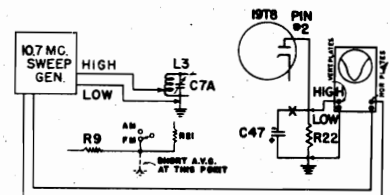

FIG. 7

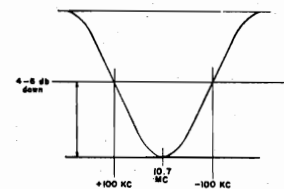

FIG. 8

POSITION OF VARIABLE	GENERATOR FREQUENCY	DUMMY ANTENNA	GENERATOR CONNECTION HIGH SIDE	GENERATOR CONNECTION GROUND LEAD	ADJUST TRIMMERS IN ORDER SHOWN FOR MAX. OUTPUT	TRIMMER FUNCTION
Open	109 Mc	300 Ohm	FM Ant. Term. ("A")	Fm Ant. Term. ("G")	⑬	Oscillator
Closed	87 Mc	300 Ohm	FM Ant. Term. ("A")	Fm Ant. Term. ("G")	Spacing of L5	Oscillator

Repeat the above oscillator adjustments until proper coverage is obtained on both ends of band since the two adjustments affect each other.

106 Mc	106 Mc	300 Ohm	FM Ant. Term. ("A")	Fm Ant. Term. ("G")	⑭	RF
90 Mc	90 Mc	300 Ohm	FM Ant. Term. ("A")	Fm Ant. Term. ("G")	Spacing of L3	RF

Repeat "RF and Oscillator adjustments until proper tracking is obtained at both 90 and 106 Mc, since tracking the set at one frequency affects the tracking at the other frequency.

All RF trimmers are adjusted for maximum output, measured with output meter across speaker voice coil.

For RF alignment, use FM generator signal modulated with 400 cycles 45 Mc sweep (22.5 Kc deviation).

MODELS 25, 27,
Ch. 478. 238

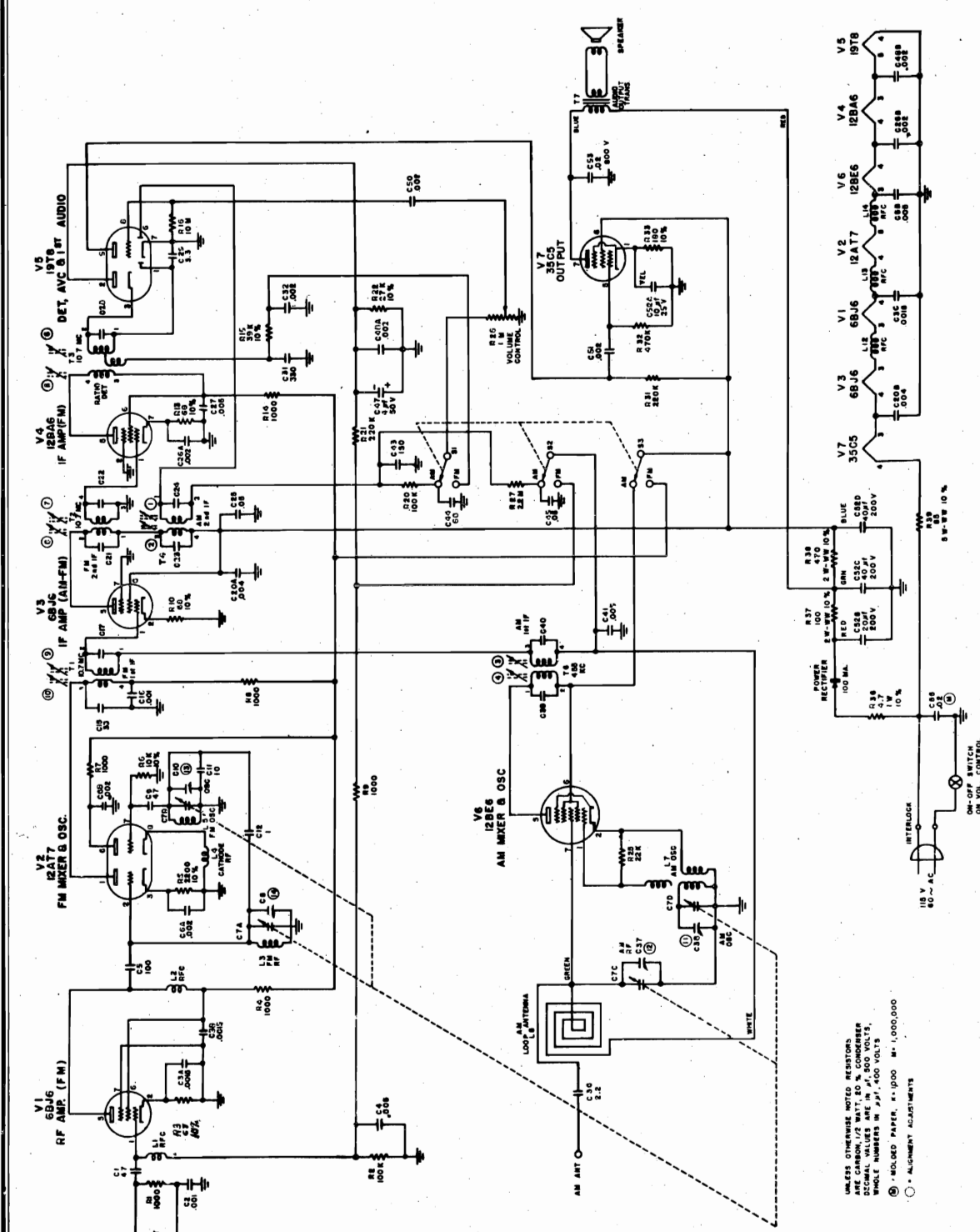

SCHEMATIC

478.238 CHASSIS

UNLESS OTHERWISE NOTED RESISTORS ARE CARBON, 1/2 WATT, 5% CONDENSERS ARE POLYSTYRENE, 50V, 5% WHOLE NUMBERS IN μ F, 100 VOLT, 5%
 (C) - ISOLATED PAPER, #1-1000 M-1,000,000
 (O) - ALIGNMENT ADJUSTMENTS

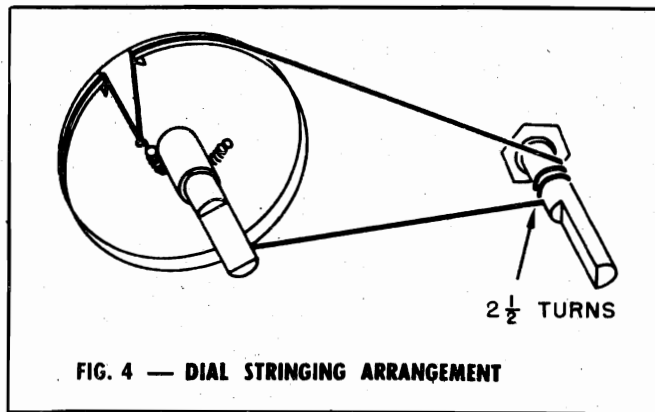

HOW TO ORDER PARTS

- 1—Use Correct Order Form.
- 2—On the Purchase Order always give the following information:
 - (1) PART NUMBER (number printed on the part if different from that shown on this list) and DESCRIPTION for each part ordered. When no part is assigned, order by description and rating. Also give PRICE of part (indicate if no selling).
 - (2) The CHASSIS NUMBER, which is 478.238. This number is found on a metal plate at the rear of the chassis.

PARTS LIST

SCHEMATIC LOCATION	PART NO.	DESCRIPTION	SELLING PRICE
RESISTORS (Carbon, 1/2 Watt ± 20% Unless Otherwise Specified)			
R 36	RC-47A-5	4.7 Ohm 1 Watt 10%	.31
R 3,10,13	RC-680-2	68 Ohm 1/2 Watt 10%	.14
R 39	RP-6	85 Ohm 5 Watt 10% W.W.	.63
R 37	RW-101-8	100 Ohm 2 Watt 10% W.W.	.29
R 33	RC-181-2	180 Ohm 1/2 Watt 10%	.14
R 38	RW-471-8	470 Ohms 2 Watts 10% W.W.	.29
R 1,4,7,8,9,14	RC-102-1	1,000 Ohms 1/2 Watt	.14
R 5	RC-222-2	2,200 Ohms 1/2 Watt 10%	.14
R 6	RC-103-2	10,000 Ohms 1/2 Watt 10%	.14
R 25	RC-223-1	22,000 Ohms 1/2 Watt	.14
R 22	RC-273-2	27,000 Ohms 1/2 Watt 10%	.14
R 15	RC-393-2	39,000 Ohms 1/2 Watt 10%	.14
R 2,20	RC-104-1	100,000 Ohms 1/2 Watt	.14
R 21,31	RC-224-1	220,000 Ohms 1/2 Watt	.14
R 32	RC-474-1	470,000 Ohms 1/2 Watt	.14
R 27	RC-225-1	2.2 Megohms 1/2 Watt	.14
P 16	RC-106-1	10 Megohms 1/2 Watt	.14
R 28	VC-23-D	Volume Control (1 Meg) & On-Off Switch	1.51
CONDENSERS			
C 12	CSP-1	1 Mmfd Stackpole	.14
C 36	CC-2,2-7	2.2 Mmfd Ceramic	.14
C 29	CC-3,3-11	3.3 Mmfd Stackpole	.23
C 11	CMS-010-8	10 Mmfd Silver Mica 50 V.	.34
C 15	CMS-033-9	33 Mmfd Silver Mica	.29
C 1,9	CC-04708	47 Mmfd Ceramic	.23
C 44	CC-068-7*	68 Mmfd Ceramic	.23
C 5	CC-101-7	100 Mmfd Ceramic	.29
C 43	CM-151-1	150 Mmfd Mica	.29
C 31	CM-231-8	330 Mmfd Mica	.29
C 2,16	CC-102-SP	.001 Mfd Ceramic GMV	.29
C 3A,B,C	CC-3-0	3 x .0015 Mfd Herlec	.57
C 26A,B,6A,B	CC-2-1	2 x .002 Mfd Herlec	.43
C 43A,B			
C 32,50,51	CP-202-2	.002 Mfd Paper	.26
C 20A,B	CC-2,2	2 x .004 Mfd Herlec	.52
C 4,27,41,58	CC-1-F	.005 Mfd Herlec	.29
C 55	CPM-203-1	.02 400 V. Molded Paper	.40
C 53	CP-203-20	.02 Mfd 800 V. Paper	.37
C 25,45	CP-503-1	.05 Mfd 400 V. Paper	.26
C 47	CE-19	4 Mfd 50 V. Electrolytic	2.65

SCHEMATIC LOCATION	PART NO.	DESCRIPTION	SELLING PRICE
CONDENSERS (Continued)			
C 52A	CE-23-D	10 Mfd 25 Volts	4 Section Electrolytic 2.74
C 52B		20 Mfd 200 Volts	
C 52C		40 Mfd 200 Volts	
C 52D		40 Mfd 200 Volts	
C 17		(part of T 1)	
C 21,22		(part of T 2)	
C 28		(part of T 3)	
C 23,24		(part of T 4)	
C 39,40		(part of T 6)	
C 8,37,38	Trimmers	(part of Variable Condenser C 7)	
C 10	TA-3	F.M. Oscillator Trimmer	.63
C 7A,7B,7C,7D	CV-23-D	Variable Condenser	4.42
COILS & TRANSFORMERS			
T 3	LF-33	Ratio Detector Transformer	2.85
T 1	LF-30	FM IF Transformer	2.42
T 2	LF-34	FM IF Transformer	1.94
T 6	LF-32	AM IF Transformer	2.78
T 4	LF-35	AM IF Transformer	1.94
L 1	LC-12	RF Coil	.14
L 5	LC-11	FM Oscillator Coil	.14
L 12,13,14	LC-13	Filament Choke	.46
L 2	LC-14	Plate Choke	.48
L 3	LC-15	Grid Choke	.46
L 4	LC-16	Cathode Choke	.46
L 7	LC-20	AM Oscillator Coil	.88
L 8	LP-23-D	Loop Antenna and Back	.91
CABINET, HARDWARE & ACCESSORIES			
	SG-1	Dial Spring	.06
	CR-2	Dial Cord	.09
	SW-15D	AM-FM Switch	1.71
	SR-2-D	Selenium Rectifier	3.45
	CB-159-M	Cabinet, Mahogany (Model 25)	3.89
	KN-39-2-D	Station Indicator Knob, Ivory. (Model 25) or	.29
	CB-159-I	Cabinet, Ivory (Model 27)	5.03
	KN-39-3-D	Station Indicator Knob, Mahogany (Model 27)	.29
	KN-40-D	Control Knobs	.20
	TLD-101	Interlock Cord	1.17
	TPL-150	Interlock Plug	.34
	SR-49-1-D	4" PM Speaker with output transformer	4.88
	IB-35-1-D	Customer Instruction Book	.15

MODEL 2061,
Ch. 101.861

SPECIFICATIONS

ANTENNA EQUIPMENT

This model has a Silvertone built-in antenna system which will provide excellent local reception under normal conditions.

For locations where an outside antenna is necessary, special noise reducing antenna kit, catalog #6705 is available. Where noise reduction is not required antenna kit, catalog #6703 may be used.

POWER SUPPLY

117 volts AC, 60 cycle unless otherwise specified. Power Consumption 105 watts.

INTERMEDIATE FREQUENCIES

AM-IF Carrier 455 KC.

FREQUENCY RANGE

Standard Broadcast 540-1600 KC.

POWER OUTPUT

Undistorted 2.4 Watts
Maximum 3.6 Watts

ALIGNMENT PROCEDURE

AM ALIGNMENT

Output meter connection _____ Across speaker voice coil
 Generator ground lead connection _____ B- Buss
 Generator modulation _____ 30% 400 cycles
 Position of volume control _____ Extreme clockwise
 Position of tone control _____ Extreme counterclockwise
 Position of AM-PHO Switch _____ AM

A Hazeltine loop may be used to radiate a signal into the receiver loop instead of the dummy antenna connections listed below.

TUNER POSITION	GENERATOR FREQUENCY	DUMMY ANTENNA	GENERATOR CONNECTION	CORE & TRIMMER ADJUSTMENTS (IN ORDER SHOWN)	CORE OR TRIMMER FUNCTION
Open	455 KC.	0.1 Mfd.	Converter Grid	T2-A, T2-B T1-C, T1-D	I. F.
1650 KC.	1650 KC.	50 Mmfd.	Ext. Ant.	C5	Osc.
1400 KC.	1400 KC.	50 Mmfd.	Ext. Ant.	C9 & C1	R. F. & Loop

Warning: No attempt should be made to adjust the alignment of this receiver without using the following equipment: Signal Generator, Output Meter, Insulated Screw Driver.

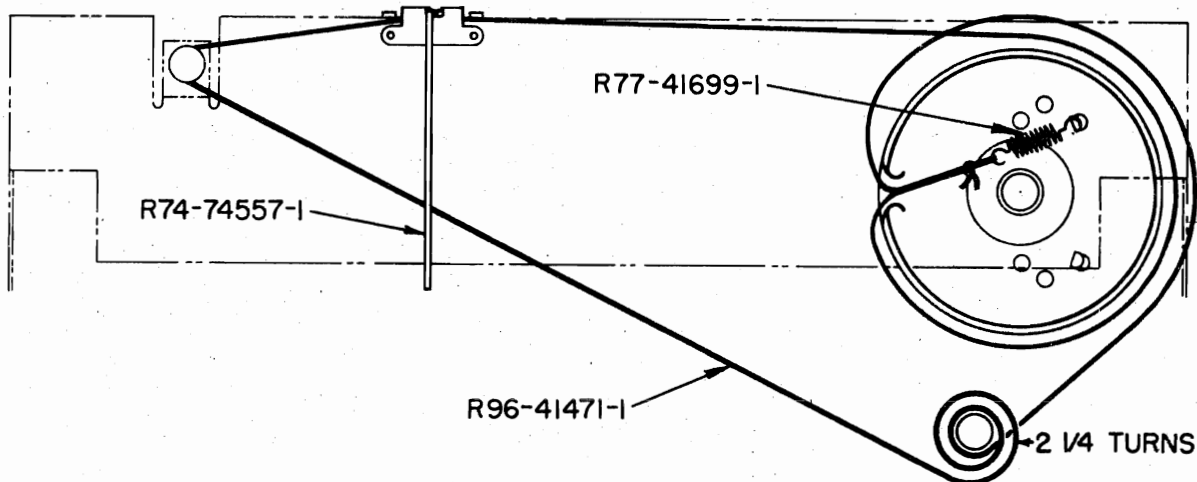

FIG. 1 - STRING AND POINTER HOOKUP

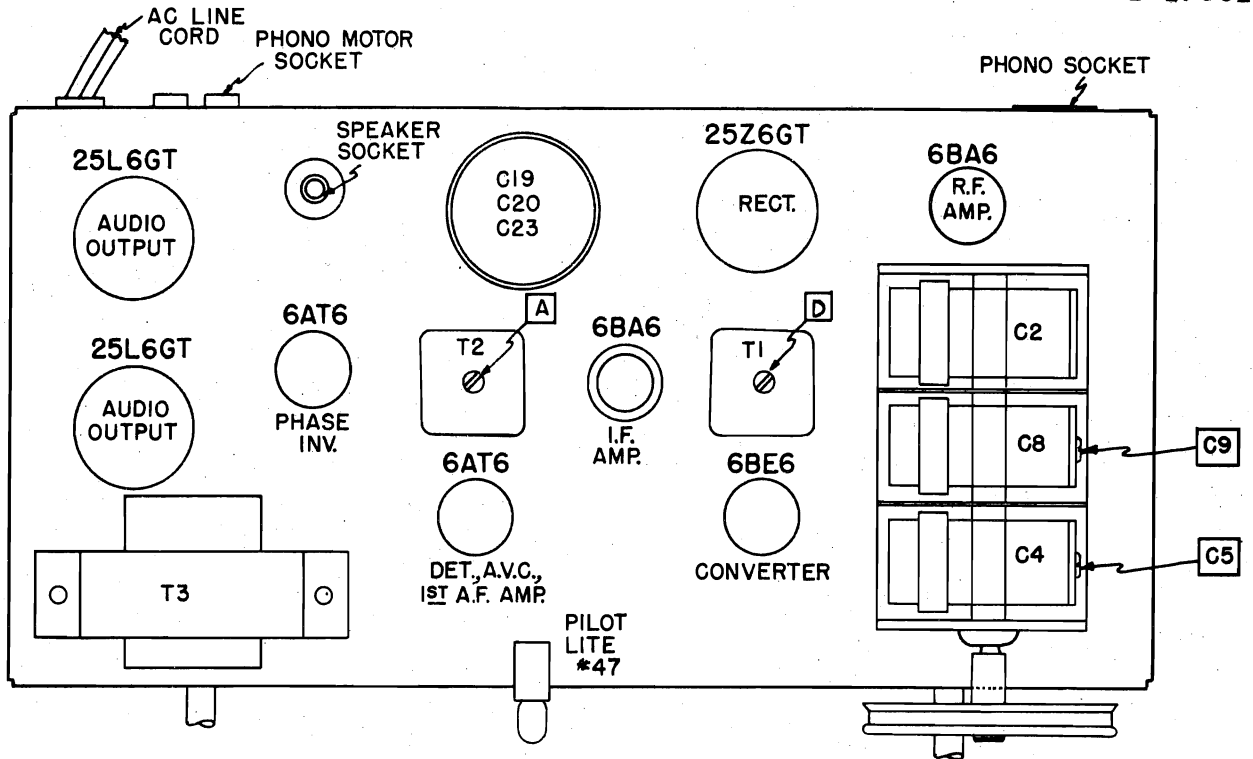

FIG. 2 - RADIO CHASSIS LAYOUT - TOP VIEW

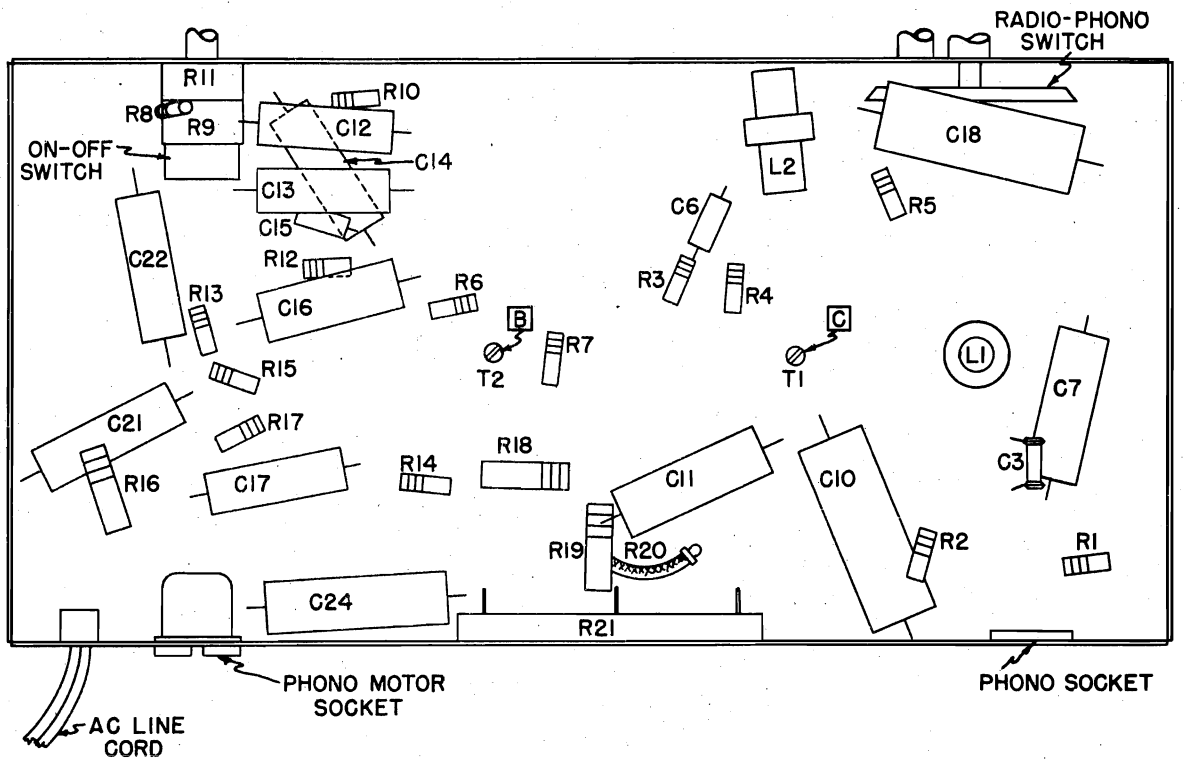

FIG. 3 - RADIO CHASSIS LAYOUT - BOTTOM VIEW

MODEL 2061,
Ch. 101.861

HOW TO ORDER PARTS

1. Use Correct Order Form.
2. On the Purchase Order always give the following information:
 - (1) PART NUMBER (number printed on the part if different from that shown in this list) and DESCRIPTION for each part ordered. When no part number is assigned, order by description and rating. Also give PRICE of part (indicate if no selling).
 - (2) The CHASSIS NUMBER, which is 101.861. This number is found on a metal plate at the rear of the chassis.

In all correspondence relating to cabinets, always mention the source code letter stamped into the upper rear rail of consoles or on the bottom of table models, and the Catalog Number shown on the sticker on the back, bottom or inside of the cabinet.

REPAIR PARTS LIST

<u>SCHEMATIC LOCATION</u>	<u>PART NUMBER</u>	<u>DESCRIPTION</u>	<u>SUGGESTED SELLING PRICE EACH</u>
	R85-61164-1	Adapter - Record	\$.06
	R74-74742-1	Background - Dial	.46
	R71-66224-1	Bushing - Line Cord	.06
	R86-74751-1	Bushing - Rubber	.06
	R71-65538-1	Button - Snap	.01
C13, C16, C17, C21, C22	R45-661032-1	Capacitor - .01 Mfd. - 600 V. - Molded	.26
C10, C18	R45-77212-1	Capacitor - .1 Mfd. - 600 V. - Molded	.17
C7, C11, C24	R45-664732-1	Capacitor - .047 Mfd. - 600 V. - Molded	.34
C14	R45-662222-1	Capacitor - .0022 Mfd. - 600 V. - Molded	.26
C12	R45-664722-1	Capacitor - .0047 Mfd. - 600 V. - Molded	.29
C3	R43-74592-4	Capacitor - 3.5 Mmfd. - Ceramic	.26
C6, C15	R43-401010-21	Capacitor - 100 Mmfd. - Ceramic	.17
	R41-77561-1	Capacitor - Electrolytic	2.85
C19		50 Mfd. - 150 V.	
C23		50 Mfd. - 150 V.	
C20		60 Mfd. - 150 V.	
C2, C4, C5, C8, C9	R42-77558-1	Capacitor - Variable - 3 Gang	3.50
	R71-67326-1	Clip - Transformer Mounting	.01
	R71-17319-1	Clip - Tuning Shaft Retaining	.02
L2	R50-77563-1	Coil - Oscillator	1.03
L1	R50-77564-1	Coil - R. F.	1.57
	R37-74577-1	Control - Dual	2.17
R9		Volume & ON-OFF - 2 Megohm	
R11		Tone - 1 Megohm	
	R19-60993-1	Cord - Line	.71
	R74-77596-1	Dial - Station - Lucite	1.97

<u>SCHEMATIC LOCATION</u>	<u>PART NUMBER</u>	<u>DESCRIPTION</u>
	R74-74555-2	Escutcheon
	R71-47266-1	Grommet
	R74-74753-1	Knob - Function
	R74-74752-1	Knob - ON-OFF & Volume
	R74-67965-2	Knob - Outer
	R30-20963-1	Lamp - Mazda #47
	R05-72626-1	Leaflet - Instruction
	R27-77566-1	Loop & Back Cover
C1		Capacitor - Antenna Trimmer
	R74-74802-1	Name Plate
	R73-67023-1	Plug - 2 Prong Female
	R74-74557-1	Pointer - Dial
	R80-67187-1	Pulley
R20	R36-62456-17	Resistor - 4.7 Ohm - FS - 1/2 W.
R1	R35-332201-1	Resistor - 22 Ohm - 1/2 W.
R2	R35-334701-1	Resistor - 47 Ohm - 1/2 W.
R3	R35-332231-1	Resistor - 22,000 Ohm - 1/2 W.
R6, R8	R35-334731-1	Resistor - 47,000 Ohm - 1/2 W.
R14	R35-338231-1	Resistor - 82,000 Ohm - 1/2 W.
R13	R35-331841-1	Resistor - 180,000 Ohm - 1/2 W.
R15	R35-333941-1	Resistor - 390,000 Ohm - 1/2 W.
R7, R12, R17	R35-334741-1	Resistor - 470,000 Ohm - 1/2 W.
R5	R35-332251-1	Resistor - 2.2 Megohm - 1/2 W.
R10	R35-331061-1	Resistor - 10 Megohm - 1/2 W.
R4	R35-331561-1	Resistor - 15 Megohm - 1/2 W.
R16	R35-436801-1	Resistor - 68 Ohm - 1 W.
R19	R35-433911-1	Resistor - 390 Ohm - 1 W.
R18	R35-435611-1	Resistor - 560 Ohm - 1 W.
R21	R36-77557-1	Resistor - *34 Ohm - 8 W. *Tapped at 17 ohms
	R71-66225-1	Retainer - Line Cord
	R81-74553-1	Shaft - Tuning
	R76-67091-1	Shield - Tube - Miniature
	R73-44897-1	Socket - 1 Prong
	R72-62405-2	Socket - Tube - 7 Prong - Min.
	R72-62460-1	Socket - Tube - 7 Prong - Min.
	R72-74694-2	Socket - Pilot Lamp
	R72-62407-1	Socket - Tube - 8 Prong - Octal
	R73-65722-1	Socket - 3 Prong

WHEN ORDERING SPEAKER PARTS
ALWAYS GIVE THE PART NUMBER
APPEARING ON THE SPEAKER

	R12-74104-7	Speaker - 10" PM
	R77-41699-1	Spring - Drive String Tension
	R96-41471-1	String - Drive (per foot)
	R33-77559-1	Switch - AM-PHO
T1	R57-77562-1	Transformer - IF #1
T2	R57-77554-1	Transformer - IF #2
T3	R56-77556-1	Transformer - Output

MODEL 2061,
Ch. 101.861

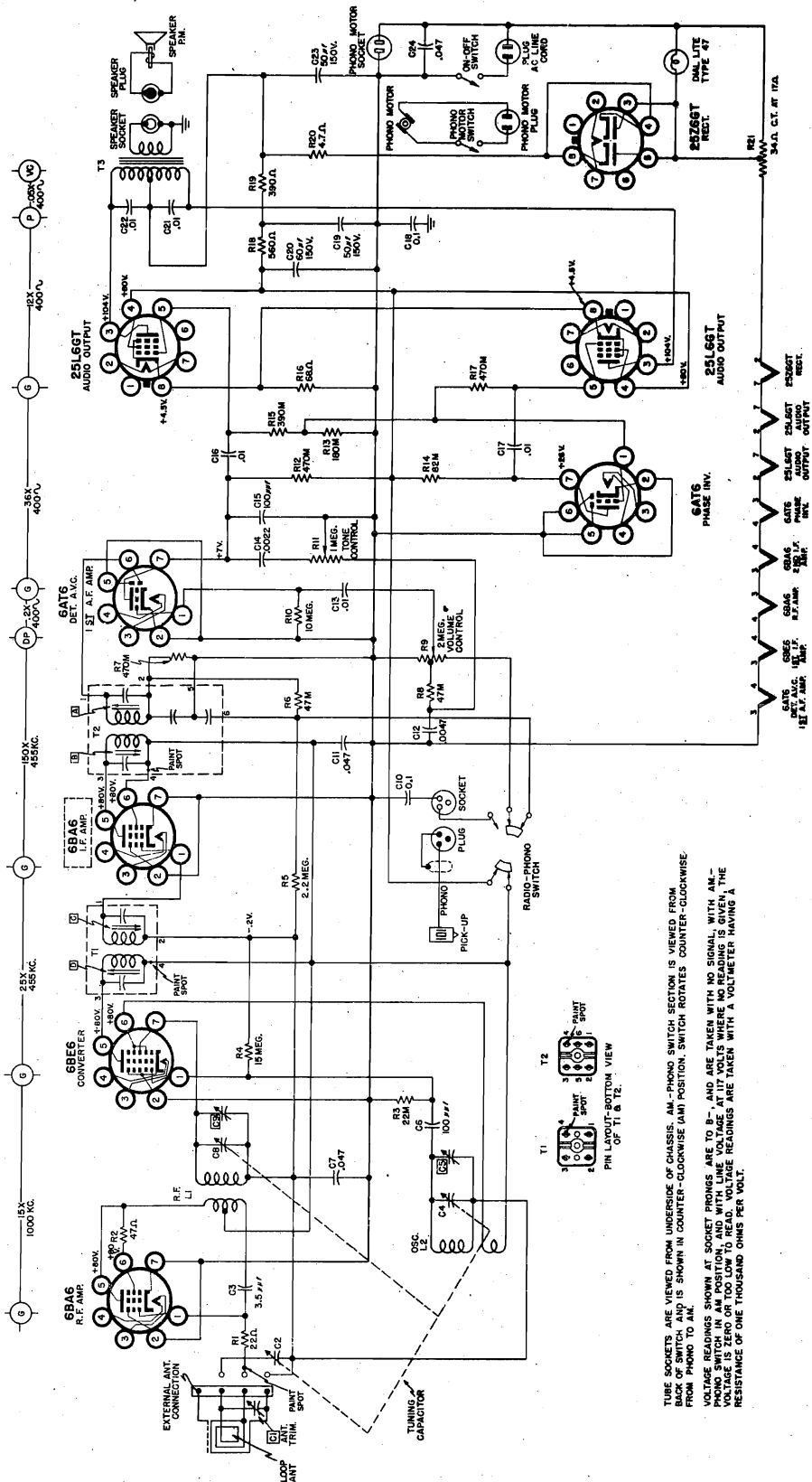

TUBE SOCKETS ARE VIEWED FROM UNDERSIDE OF CHASSIS. AM-PLUGS SWITCH SECTION IS VIEWED FROM BACK OF SWITCH AND IS SHOWN IN COUNTER-CLOCKWISE (AM POSITION). SWITCH ROTATES COUNTER-CLOCKWISE FROM PHONO TO AM. VOLTAGE READINGS SHOWN AT SOCKET PRONGS ARE TO B- AND ARE TAKEN WITH NO SIGNAL. WITH AM-PLUGS SWITCH IN AM POSITION, AND WITH LINE VOLTAGE AT 117 VOLTS WHERE NO READING IS GIVEN, THE RESISTANCE OF ONE THOUSAND OHMS PER VOLT.

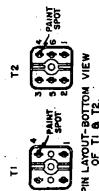

SCHEMATIC DIAGRAM FOR 101.861 RADIO CHASSIS

MODELS 2060,
2061, Ch. 101.861-1

Chassis 101.861-1 is the same as 101.861 except for new IF Transformers and change in neutralizing capacitor.

Except for the Repair Parts listed below and the schematic diagram on page below refer to Ch. 101.861 for all Service Information, Repair Parts, and Ordering Instructions.

SCHEMATIC LOCATION	PART NUMBER	DESCRIPTION
--------------------	-------------	-------------

SUPPLEMENT I	C3	Capacitor - 2 Mmfd. - Ceramic
	T1	Transformer - IF #1
	T2	Transformer - IF #2

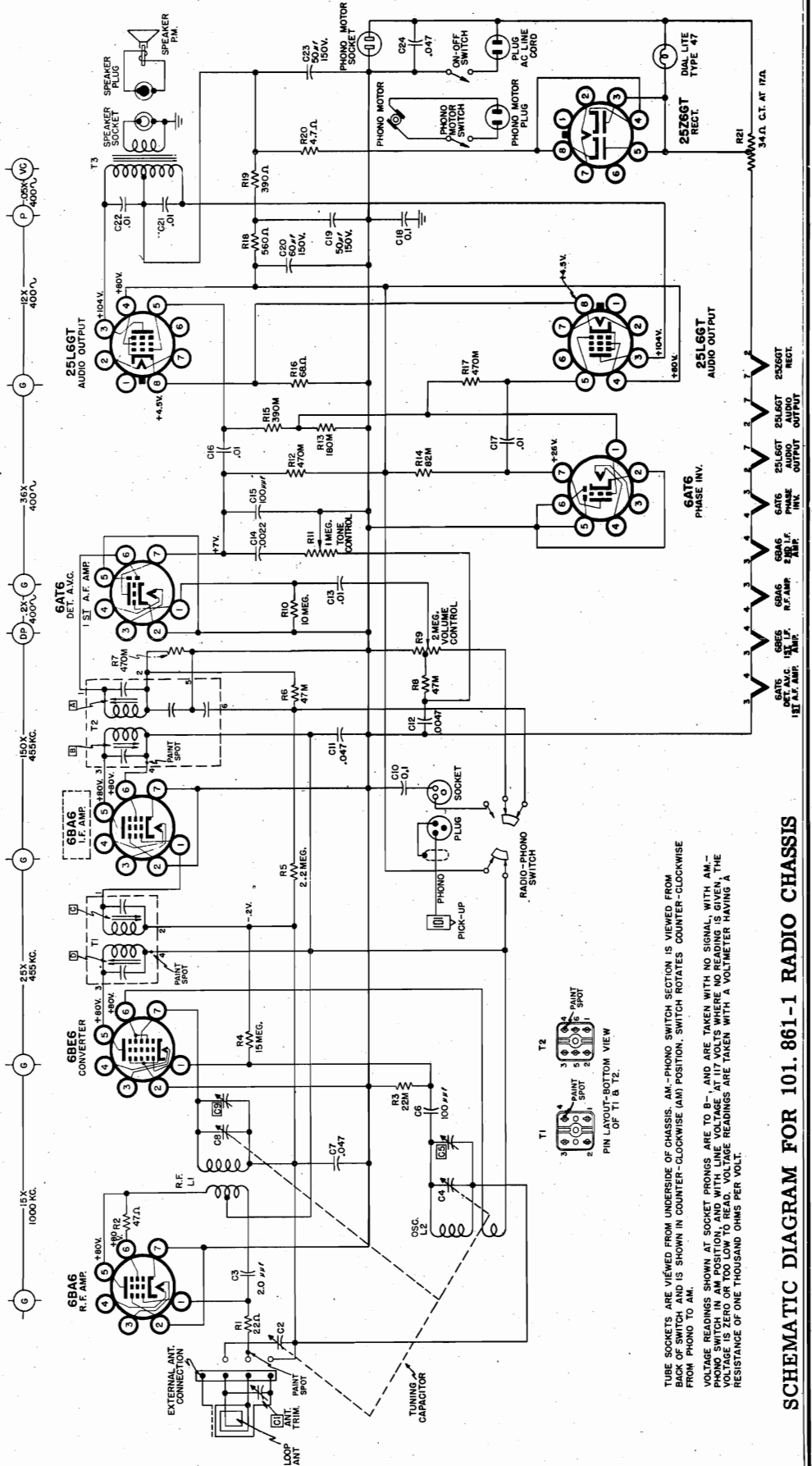

TUBE SOCKETS ARE VIEWED FROM UNDERSIDE OF CHASSIS. AM.-PHONO SWITCH SECTION IS VIEWED FROM BACK OF SWITCH AND IS SHOWN IN COUNTER-CLOCKWISE (AM) POSITION, SWITCH ROTATES COUNTER-CLOCKWISE FROM PHONO TO AM.

VOLTAGE READINGS SHOWN AT SOCKET PRONGS ARE TO B- AND ARE TAKEN WITH NO SIGNAL, WITH AM.-PHONO SWITCH IN AM POSITION, AND WITH LINE VOLTAGE AT 117 VOLTS WHERE NO READING IS GIVEN, THE PHONO SWITCH IS IN AM POSITION. ALL VOLTAGE READINGS ARE TAKEN WITH A VOLTMETER HAVING A RESISTANCE OF ONE THOUSAND OHMS PER VOLT.

SCHEMATIC DIAGRAM FOR 101.861-1 RADIO CHASSIS

MODELS 3061,
3062, Ch. 101.861-1

3061, 3062 SUPPLEMENT 2

Chassis 101.861-1 is the same as 101.861 except for new IF Transformers and change in neutralizing capacitor.

Except for the change in the Repair Parts listed below refer to Ch. 101.861 for all Service Information, Repair Parts and Ordering Instructions.

<u>SCHEMATIC LOCATION</u>	<u>PART NUMBER</u>	<u>DESCRIPTION</u>
C3	R74-74742-2	Background - Dial
	R43-74592-5	Capacitor - 2 Mmfd. - Ceramic
	R74-83733-1	Dial - Station - Lucite
	R74-74555-4	Escutcheon
	R74-74752-3	Knob - Function
	R74-74752-2	Knob - ON - OFF & VOLUME
	R74-67965-3	Knob - Outer
	R05-72931-1	Leaflet - Instruction
	R57-78878-1	Transformer - IF #1
	R57-78879-1	Transformer - IF #2
T1		<u>ADDITIONS</u>
T2		
C3	R74-74742-1	Background Dial
	R43-74592-4	Capacitor - 3.5 Mmfd. - Ceramic
	R74-77596-1	Dial - Station - Lucite
	R74-74555-2	Escutcheon
	R74-74753-1	Knob - Function
	R74-74752-1	Knob - ON - OFF & VOLUME
	R74-67965-2	Knob - Outer
	R05-72626-1	Leaflet - Instruction
	R57-77562-1	Transformer - IF #1
	R57-77554-1	Transformer - IF #2
T1		<u>DELETIONS</u>
T2		

MODELS 3004, 3005,
3006, Ch. 757.130

SPECIFICATIONS

Power Supply
105-120 Volts AC-DC 35 Watts, 50-60 Cycles.

Frequency Range
Broadcast 355-1640 KC

Power Output
Undistorted 1.2 Watt
Maximum 2.2 Watt

Speaker Voice Coil Impedance 3.2 ohms

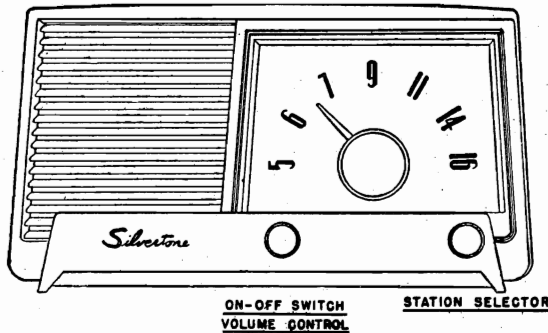
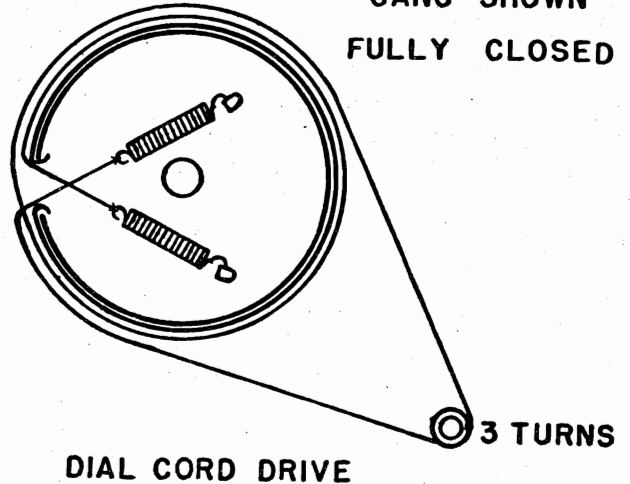
GANG SHOWN
FULLY CLOSED

TECHNICAL INFORMATION FOR SERVICE MEN

Tuning Range 535 Kc to 1640 Kc. Intermediate frequency—455 Kc. IF and RF measurements made at 0.5 watt output—approximately 1.27 volts on a rectifier type voltmeter connected across the voice coil.

Approximate inputs for .5 watt output: IF 50 uv, RF with standard loop: at 600 Kc, 500 uv/m; at 1000 Kc, 350 uv/m; at 1400Kc, 250 uv/m.

ALIGNMENT DATA

Position of Variable	Generator Frequency	Dummy Ant.	Generator Connection (high)	Generator Connection (low)	Adjust Trimmers (In order shown)	Trimmer Function
Open	455 Kc	.05 mfd	Mixed Grid	Float Gnd.	A4, A3, A2, A1	I.F.
Open (Fully)	1640 Kc	50 mmf	*	Float Gnd.	A6	Osc.
1400 Kc	1400 Kc	50 mmf	*	Float Gnd.	A5	Ant.
1000 Kc	1000 Kc	50 mmf	*	Float Gnd.	Check Point	
600 Kc	600 Kc	50 mmf	*	Float Gnd.	Check Point	

* A loop fashioned of several turns of wire radiating the signal into receiver's antenna or through the external antenna connection.

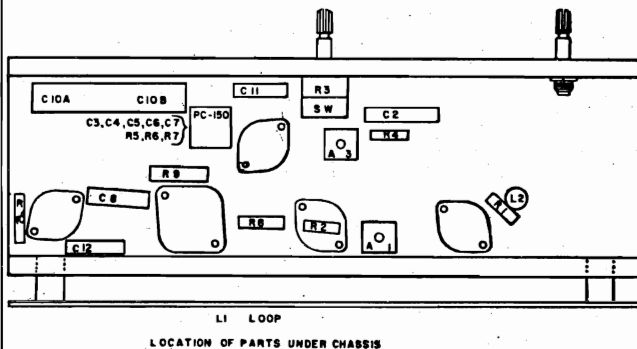

LOCATION OF PARTS UNDER CHASSIS

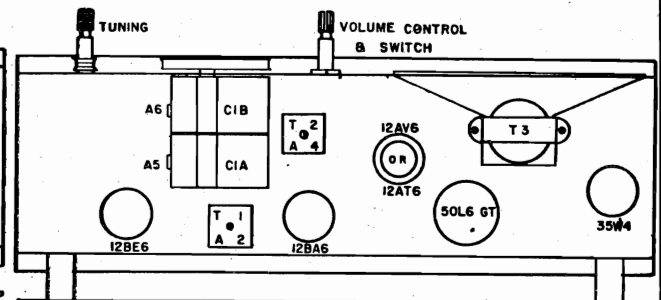

LOCATION OF TUBES AND TRIMMERS

MODELS 3004, 3005,
3006, Ch. 757.130

HOW TO ORDER PARTS

1. Use Correct Order Form.
2. On the Purchase Order always give the following information:
 - (1) PART NUMBER (number printed on the part if different from that shown in this list) and DESCRIPTION for each part ordered. When no part number is assigned, order by description and rating. Also give PRICE of part (indicate if no selling).
 - (2) THE CHASSIS NUMBER, which is 757.130. This number is found on a metal plate at the rear of the chassis.

Schematic Location	Part No.	Description	List Price	Schematic Location	Part No.	Description	List Price
	E7010	Cabinet, Brown	\$5.00		E5921	Leaflet, Instruction	\$.17
	E7011	Cabinet, Ivory	7.00	L1	E603	Loop, Antenna and Rear Cover Assembly	1.57
	E7012	Cabinet, Green	7.70		E454	Pointer, Dial	.57
L2	E619	Coil, Oscillator	1.01	R1		Resistor, 22K Ohms, 1/2W	.17
C1A, C1B	E356	Condenser Variable, 2-Gang With Drum	3.12	R2		Resistor, 180 Ohms, 1/2W	.17
C2, C11	E306	Condenser, P.T., .05 MFD, 400V.	.51	R3	E254	Resistor, .5 Meg. Ohms, Volume Control with Switch	1.43
C3, C6, C7		Condenser, 220 MMF, Ceramic		R4		3.3 Meg. Ohms, 1/2W	.17
C4	E3015	Condenser, .002 Mfd, Ceramic	1.01	R5	E3015	Resistor, 6.8 Meg. Ohms	1.01
C5	(PC-150)	Condenser, .005 Mfd, Ceramic		R6, R7	(PC-150)	Resistor, 470K Ohms	
C8	E301	Condenser, P. T., .01 Mfd, 600V	.29	R8		Resistor, 120 Ohms, 1/2W	.17
C10A, C10B	E325	Condenser Electrolytic 50-30 Mfd, 150V	1.71	R9		Resistor, 1500 Ohms 1W	.33
C12	E342	Condenser, Molded Paper, .047 Mfd, 400V	.37	R10		Resistor, 22 Ohms, 1/2W	.17
P	E894	Cord, Line, with Plug	.71		E432	Shaft, Drive Assembly	.71
	E453	Cord, Dial	.14		E452	Spring, Dial	.17
	E4020	Dial Pan	1.57	T3	E105	Speaker Assembly, Includes 5 1/4" PM SPK., & 1/2 x 1/2 Output Transformer	5.20
	E509B	Knobs, Brown	.20	T1, T2	E622	Transformers, I.F.	1.85
	E509I	Knobs, Ivory	.26		E716	Window, Styrene	1.85
	E509G	Knobs, Green	.26				
	E5922	Label, Identification	.14				

MODELS 3052,
3053, Ch. 132.053

SPECIFICATIONS

Power Supply	105-120 volts 60 cycle AC, 65 watts	Power Output	Undistorted .8 watts
Frequency Range	Broadcast - 1600 - 540 Kc.	Maximum	1.5 watts
	3052 and 3053 have three speed record changer 488.219-4.	Speaker Voice Coil Impedance	3.2 ohms

TECHNICAL INFORMATION FOR SERVICEMEN

Tuning range 540 Kc. to 1600 Kc. Intermediate frequency---455 Kc. I-F and r-f measurements made at .5 watt output---approximately 1.26 volts on a rectifier type voltmeter connected across the voice coil.

Approximate inputs for .5 watt output: I-F with standard loop: at 600 Kc 500 uv/m; at 1000 Kc. 400 uv/m; at 1400 Kc. 400 uv/m. R-F external antenna connection: at 600 Kc 250 uv; at 1000 Kc. 200 uv; at 1400 Kc. 200 uv.

ALIGNMENT PROCEDURE

Position of Variable	Generator Frequency	Dummy Ant.	Generator Connection (high)	Generator Connection (low)	Adjust Trimmers (in order shown)	Trimmer Function
Open	455 Kc.	.05 uf	Pin 8 of 12SA7	Float. Gnd.	A1, A2, A3, A4,	I. F.
Open	1650 Kc.	50 uuf	Ext. Ant. Conn.	Float. Gnd.	A5	Oscillator
1400 Kc.	1400 Kc.	50 uuf	Ext. Ant. Conn.	Float. Gnd.	A6, A7	R. F. Ant.
600 Kc.	600 Kc.	50 uuf	Ext. Ant. Conn.	Float. Gnd.	Check Point	

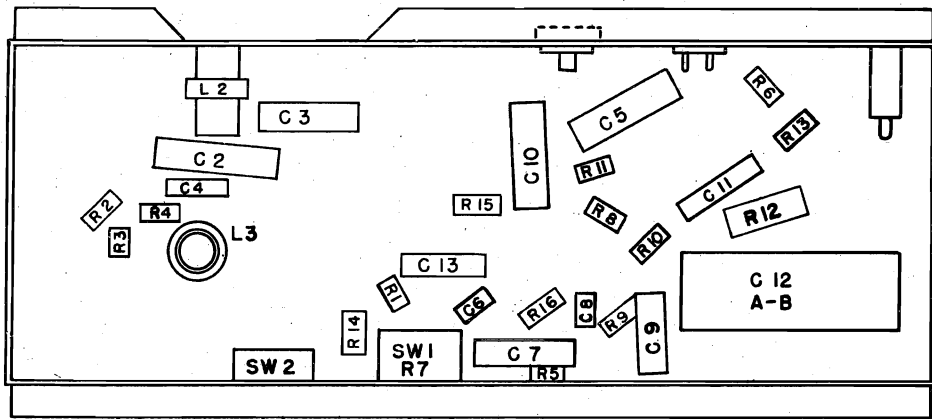

LOCATIONS OF PARTS UNDER CHASSIS

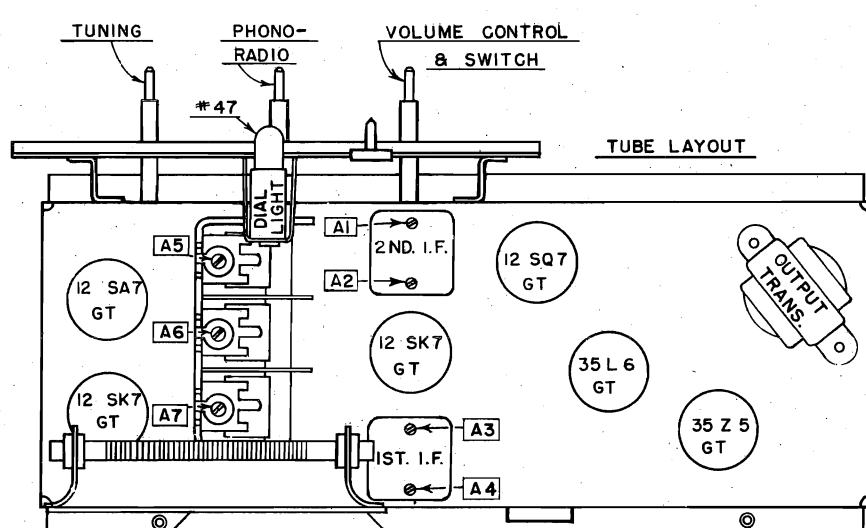

MODELS 3052,
3053, Ch. 132.053

HOW TO ORDER PARTS

1. Use Correct Order Form.
2. On the Purchase Order, always give the following information:
 - (1) PART NUMBER (number printed on the part if different from that shown in this list) and DESCRIPTION for each part ordered. When no part number is assigned, order by description and rating. Also give PRICE of part (indicated if no selling).
 - (2) THE CHASSIS NUMBER, which is 132.053 for Radio Chassis and 488.219-4 for the three speed changer.

In all correspondence relating to cabinet, always mention the source code letter stamped into the upper rear rail of consoles or the bottom of table models, and the CATALOG NUMBER shown on the sticker on the back, bottom or inside of cabinet.

PARTS LIST

<u>SCHEMATIC LOCATION</u>	<u>PART NO.</u>	<u>DESCRIPTION</u>	<u>LIST</u>
<u>CAPACITORS</u>			
C1A, B, C	N40761	Variable, 3-Gang	3.90
C2, C5		.05 uf, 400V. P.T.	.23
C3, C10		.05 uf, 200V. P.T.	.23
C4		50 uuf, 500V. Mica.	.23
C6, C8		220 uuf, 350V. Ceramic	.23
C7, C9, C11		.01 uf, 400V. P.T.	.23
C12A, B	N24249	Electrolytic, 80-50 uf, 150V.	2.22
C13		.001 uf, 200V. P.T.	.23
<u>RESISTORS</u>			
R1, R9		330K ohms, 1/2W.	.15
R2		2200 ohms, 1/2W.	.15
R3		22K ohms, 1/2W.	.15
R4		6.8 megohms, 1/2W.	.15
R5		1 megohm, 1/2W.	.15
R6		15 ohms, 1/2W.	.15
R7, SW-1	N40801	500K ohms, Volume Control with Switch	1.25
R8		3.3 megohm, 1/2W.	.15
R10		470K ohms, 1/2W.	.15
R11, R13		150 ohms, 1/2W.	.15
R12		1000 ohms, 2W.	.20
R14		33K ohms, 1/2W.	.15
R15		68 ohms, 1/2W.	.15
<u>CHOKES, COILS & TRANSFORMERS</u>			
L2	N25706-1	Coil, R. F.	.70
L3	N23751-1	Coil, Oscillator	.66
T1	N25728-1	Transformer, 1st I. F.	1.77
T2	N25729-1	Transformer, 2nd I. F.	1.91
T3	N23931-1	Transformer, Output	2.50

MODELS 3052,
3053, Ch. 132.053

.26
.28
.43
2.00
.23
.40
.11
5.10
.06
1.19
.75

Lamp, Dial, Mazda, #47
Leaflet, Instruction
Pointer, Dial
Antenna Loop, Assy.
Socket, Dial Light, with Leads
Socket, Phono Motor
Speaker, 5 x 7 P.M.
Spring, Dial Cord
Switch, Radio-Phono
Weight, Cabinet

L N19351
N40821
N40805
L1 N25657-1
N25663
N19551
N24212
N24817
N19133
SW-2 N40781
N22763

MISCELLANEOUS
Cord, Dial Drive
Cord, Line, with Plug
Cover, Rear Cabinet
Escutcheon & Dial Assembly
Dial Escutcheon (Part of N40775-1)
Dial Scale, Glass (Part of N40775-1)
Knob, On-Off-Volume, Tuning
Knob, Radio-Phono Switch

P N19132
N20138-15
N23484
N40775-1
N40811
N40803
N40799-1
N40799-2

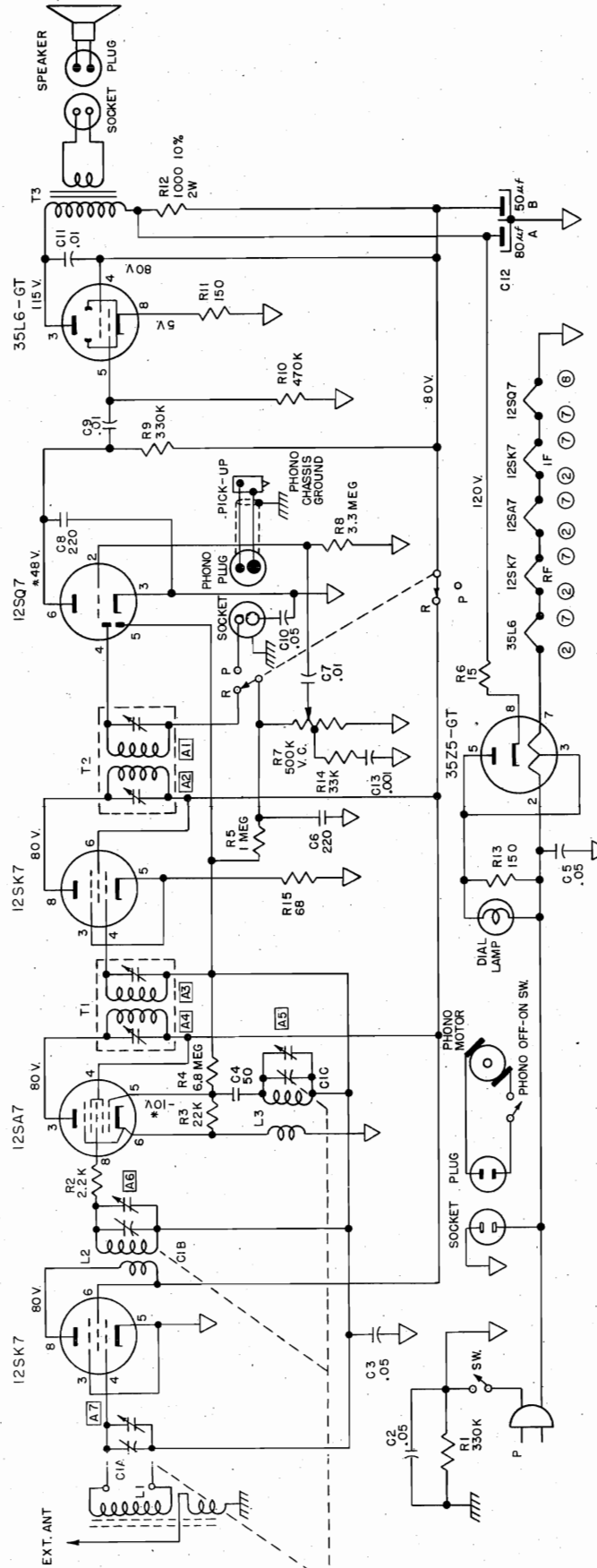

VOLTAGE READINGS TAKEN WITH 117V. A.C. LINE VOLTAGE.
* THESE READINGS TAKEN WITH VACUUM TUBE VOLTMETER.
∇ FLOATING GROUND.
⌚ CHASSIS GROUND.
⌚ CURVED LINE DENOTES OUTSIDE FOIL.
RESISTANCE VALUES ARE IN OHMS: K = 1,000, MEG = 1,000,000.
CAPACITANCE VALUES LESS THAN (1) ARE IN MICROFARADS, (μF),
AND VALUES OF (1) OR GREATER ARE IN MICRO-MICROFARADS, (μμF),
UNLESS OTHERWISE INDICATED

MODEL 1017,
Ch. 528.210

SPECIFICATIONS

Power Supply:

Power Output:

Undistorted 1.0 Watt

Maximum 2.2 Watt

117 Volts, DC or 56-60 Cycles AC, 40 Watts

Frequency Range:

Broadcast 535-1605 KC

ALIGNMENT PROCEDURE

Output meter reading to indicate 0.05 watt across voice coil 0.4 v.
 Generator ground lead connected To B- through 0.1 mfd. capacitor
 Generator modulation 30%, 400 cycles
 Position of volume control Fully on
 Position of pointer with tuner fully closed Pointer should be horizontal, pointing
 to left (9 o'clock).

POSITION OF TUNER	GENERATOR FREQUENCY	DUMMY ANTENNA	GENERATOR CONNECTION	TRIMMER ADJUSTMENT	TRIMMER FUNCTION
Open	455 KC	0.1 mfd.	pin 7 6BE6	T2 (top & bottom)	2nd I.F.
Open	455 KC	0.1 mfd.	pin 7 6BE6	T1 (top & bottom)	1st I.F.
Open	1610 KC	0.1 mfd.	pin 7 6BE6	C1C (trimmer)	Oscillator
1400 KC	1400 KC	Hazeltine test loop		C1B (trimmer)	R.F.
1400 KC	1400 KC	Hazeltine test loop		C1A (trimmer)	Antenna

ALIGNMENT NOTES:

1. It is recommended that this set be connected to an isolation transformer when aligning on AC.
2. The alignment must be done in the order given above.
3. While making the above adjustments, keep the volume control set for maximum output and the signal generator output attenuated to avoid AVC action.

MODEL 1017,
Ch. 528.210

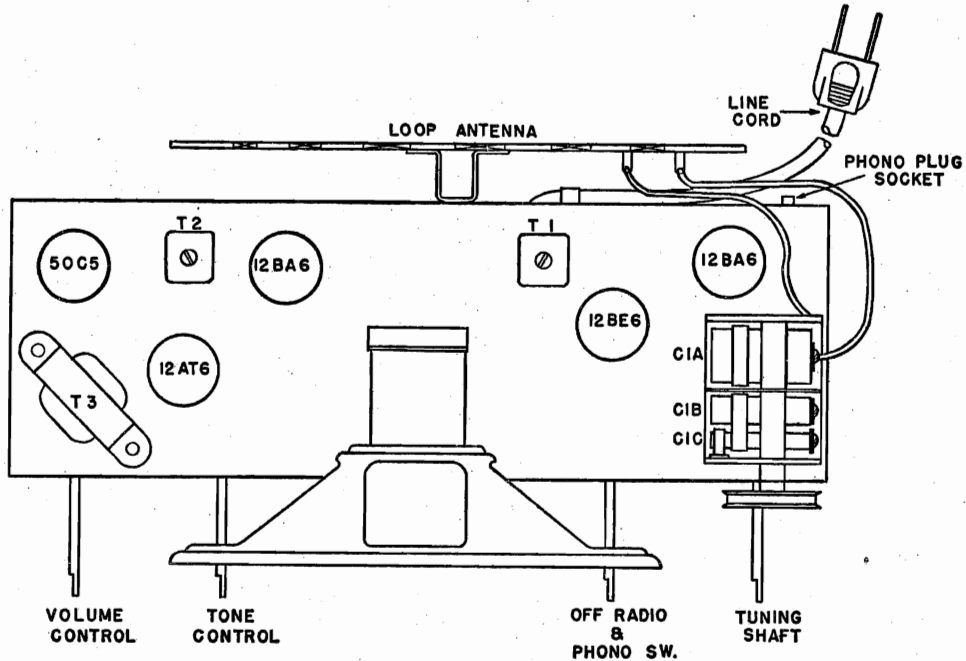

CHASSIS TOP VIEW

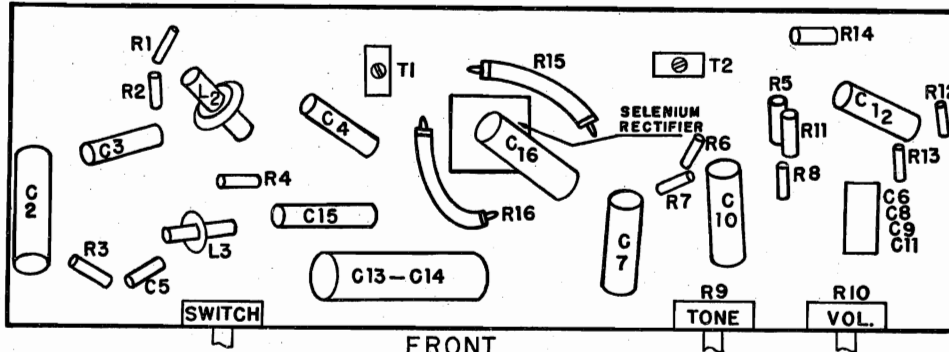

CHASSIS BOTTOM VIEW

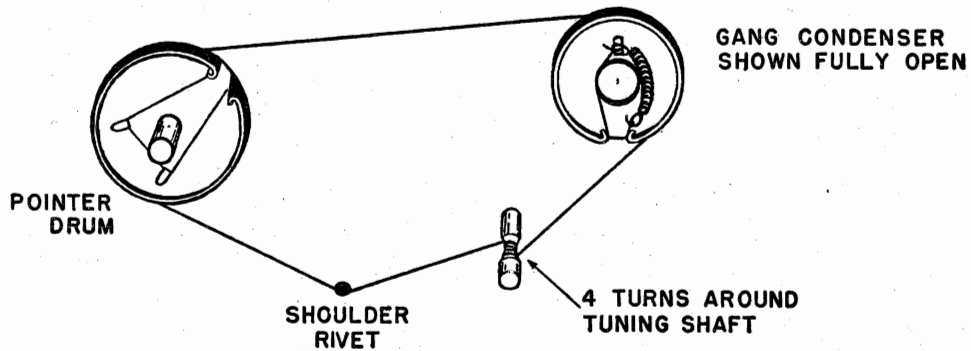

DIAL STRINGING

50C5

12AT6

12BA6

12BE6

12BA6

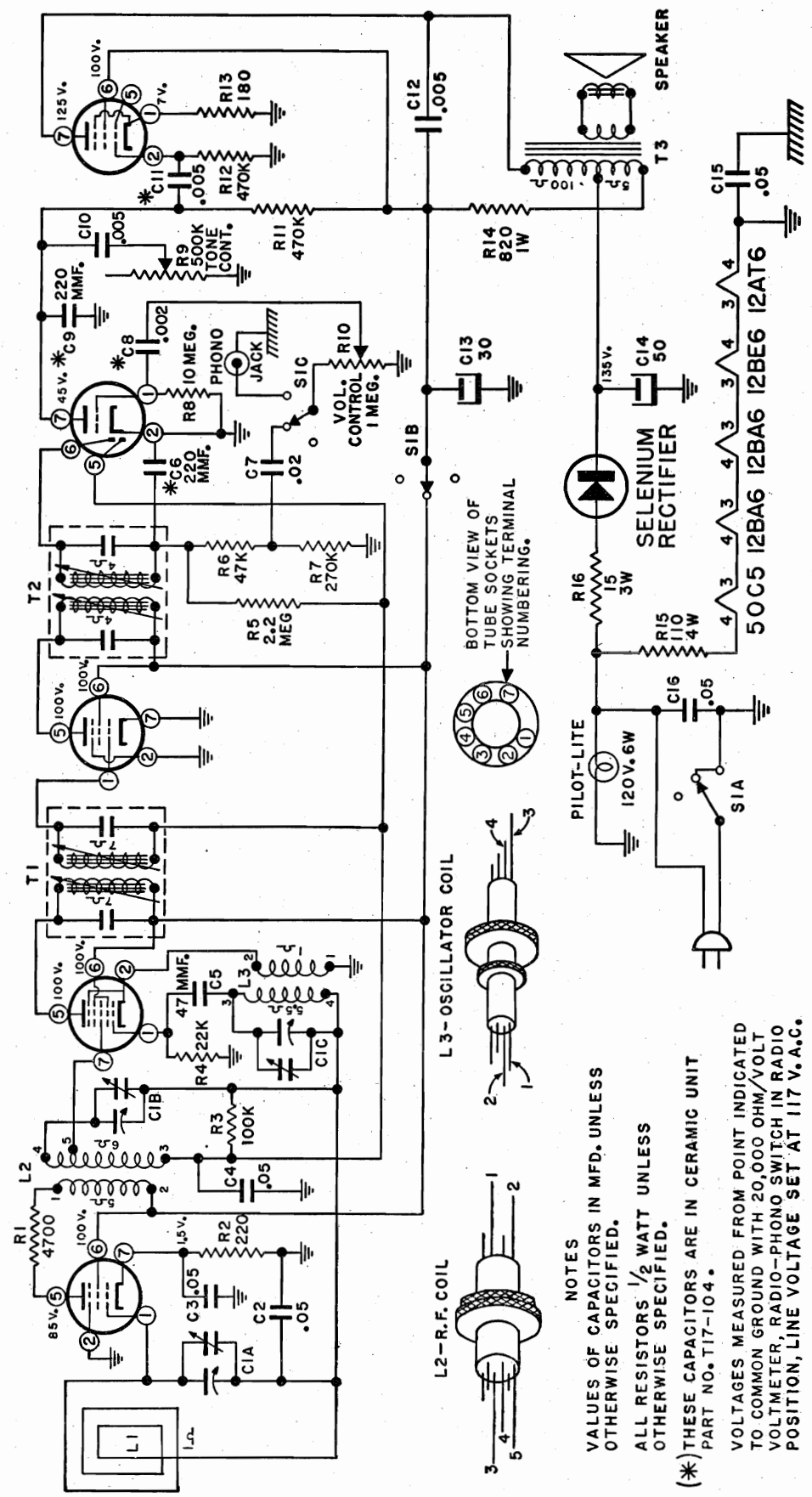

L2-R.F. COIL

L3-OSCILLATOR COIL



BOTTOM VIEW OF TUBE SOCKETS SHOWING TERMINAL NUMBERING.

NOTES
 VALUES OF CAPACITORS IN MFD. UNLESS OTHERWISE SPECIFIED.
 ALL RESISTORS 1/2 WATT UNLESS OTHERWISE SPECIFIED.
 (*) THESE CAPACITORS ARE IN CERAMIC UNIT PART NO. T17-104.

VOLTAGES MEASURED FROM POINT INDICATED TO COMMON GROUND WITH 20,000 OHM/VOLT VOLTMETER, RADIO-PHONO SWITCH IN RADIO POSITION, LINE VOLTAGE SET AT 117 V.A.C.

MODEL 1017,
Ch. 528.210

HOW TO ORDER REPAIR PARTS

1. Use Correct Order Form.
2. On the Purchase Order always give the following information:
 - (1) PART NUMBER (number printed on the part if different from that shown in this list) and DESCRIPTION for each part ordered. When no part number is assigned, order by description and rating. Also give PRICE of part (indicate if no selling).
 - (2) The CHASSIS NUMBER, which is 528.210. This number is found on a metal plate at the rear of the chassis.

Schematic Location	Part Number	DESCRIPTION
C1A, C1B, } C1C	T83-713	Back, cabinet
C2, C3, C4	T44-20	Baffle, wood
C5	T72-56	Bushing, pulley
C6, C8, } C9, C11 }	T42-509	Cabinet
C10, C12	T19-215	Capacitor, variable (3 gang)
C13, C14	T16-197	Capacitor, .05 mfd. 200 v.
C15, C16	T15-229	Capacitor, 47 mfd. mica
L2	T17-104	Capacitor, ceramic unit
L3	T16-150	Capacitor, .02 mfd. 400 v.
R9	T16-190	Capacitor, .005 mfd. 600 v.
R10	T18-304	Capacitor, electrolytic; 50-30 mfd. 150 v.
	T16-189	Capacitor, .05 mfd. 400 v.
	T11-187	Clamp, power cord
	T83-421	Clip, IF transformer mounting
	T10-535	Coil, R.F.
	T10-573	Coil, oscillator
	T26-129	Control, TONE (500K)
	T24-199	Control, VOLUME (1 meg.)
	T23-151	Cord, power line
	T51-109	Cord, dial drive, approx. 18 in.
	T37-136	Cover, insulator (pilot lamp)
	T67-565	Dial scale, plate
	T98-23	Grille cloth, cabinet
	T98-24	Grille cloth, baffle
	T47-108	Grommet (gang mounting)
	T52-347	Knob, VOLUME
	T52-348	Knob, TONE
	T52-349	Knob, TUNING
	T52-350	Knob, OFF-RADIO-PHONO
	T88-321	Label, schematic, parts list, etc.
	T89-9	Lamp, pilot, 120 v. 6 w.
L1	T82-73	Loop, antenna
	T58-88	Pointer, lucite
	T39-290	Pulley, pointer drive
R1	T83-561	Rectifier, selenium (75 ma.)
R2	T60-759	Resistor, 4700 ohm, 1/2 w. 10%
	T60-753	Resistor, 220 ohm, 1/2 w. 10%
	T60-727	Resistor, 100K ohm, 1/2 w.
	T60-659	Resistor, 22K ohm, 1/2 w.
	T60-726	Resistor, 2.2 megohm, 1/2 w.
	T60-730	Resistor, 47K ohm, 1/2 w.
	T60-747	Resistor, 270K ohm, 1/2 w. 10%
	T60-728	Resistor, 10 megohm, 1/2 w.
	T60-731	Resistor, 470K ohm, 1/2 w.
	T60-774	Resistor, 180 ohm, 1/2 w. 10%
	T60-874	Resistor, 820 ohm, 1 w. 10%
	T60-876	Resistor, 110 ohm, 4 w. 10%
	T60-738	Resistor, 15 ohm, 3 w. 10%
	T74-195	wirewound
	T74-266	Screw, #8-32 x 3/16 in. (chassis mounting)
	T74-176	Screw, #6-32 x 3/16 in. (fasten baffle to speaker)
	T97-150	Screw, #8-32 x 5/8 in. (dial plate mounting)
	T97-134	Screw, wood, #5 x 3/8 in. (back cover)
	T75-85	Screw, wood, #5 x 3/8 in. (pilot lamp cover)
	T75-88	Shaft, pointer and pulley
	T71-54	Shield, pilot lamp
	T68-51	Socket, 7 pin, miniature
	T68-52	Socket, 7 pin, miniature, with tube shield
	T87-47	Socket, pilot lamp
	T22-133	Socket, phono
	T77-151	Spacer, gang mounting
	T79-394	Speaker, 5 in. x 7 in. P.M.
	T70-135	Spring, dial cord
	T69-191	Switch, OFF-ON-RADIO-PHONO
	T10-521	Transformer, 1st I.F.
	T10-529	Transformer, 2nd I.F.
	T80-270	Transformer, output
	T86-51	Washer, "C", tuning shaft

SUPPLEMENT No. 1

Chassis 528.210-1 is the same as 528.210 except that an antenna coupling has been added to the loop.

The repair parts list for chassis 528.210-1 is the same as 528.210 except for the following changes:

Schematic Location	Part Number	DESCRIPTION
REMOVE: C1A, C1B, C1C	T19-215	Capacitor, variable (3 gang).....
L1	T82-73	Loop, antenna
L2	T10-535	Coil, R.F.
L3	T10-573	Coil, oscillator

ADD:		
C1, A, B&C	T19-217	Capacitor, variable (3 gang).....
	T83-517	Clip
L1	T82-78	Loop antenna
L2		(Part of Loop antenna)
L3	T10-535	Coil, R.F.
L4	T10-573	Coil, oscil'ator

Chassis 528.210-2 is the same as 528.210-1 except as follows:

The primary of L3 has been rewired so that Terminal No. 2 is now connected to Terminal No. 5 of the 12BA6 RF tube socket. R1 is connected between Terminal No. 1 of the RF coil and Terminal No. 6 of the 12BA6 socket.

The repair parts list for chassis 528.210-2 is the same as 528.210-1 except for the following change:

Part No. T60-759 (located on the schematic diagram at R1) Resistor, 4700 ohm, $\frac{1}{2}$ w., 10% has been removed.

Part No. T60-786 (also located at R1 on the schematic diagram) Resistor, 6800 ohm, $\frac{1}{2}$ w., 10% has been added.

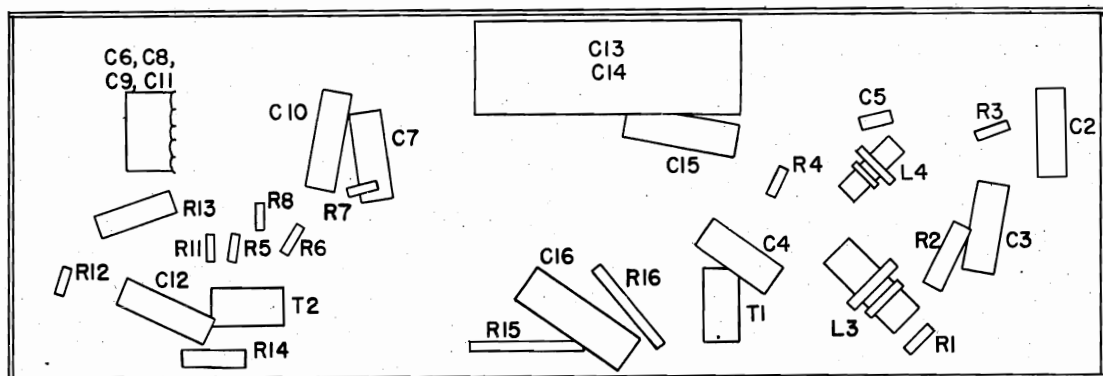
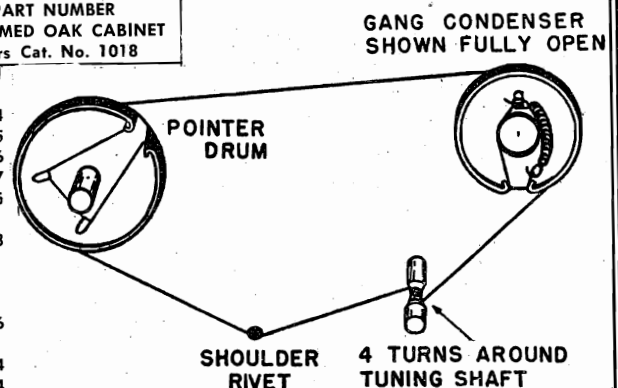
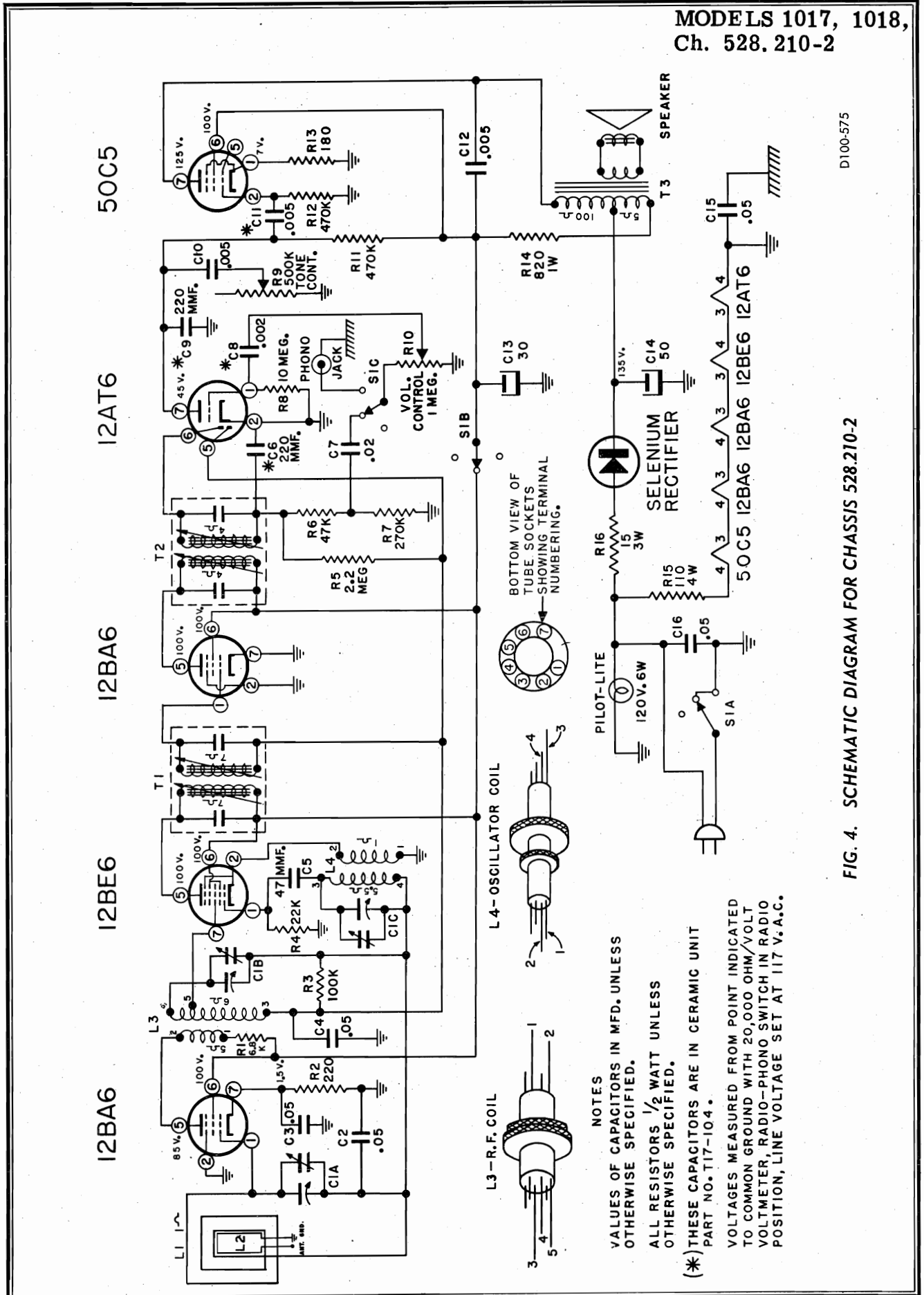

Fig. 1. Bottom View of Chassis 528.210-1 and Chassis 528.210-2

Complete cabinet lists for No. 1017 and 1018 follow.

PART NUMBER FOR MAHOGANY CABINET Sears Cat. No. 1017	DESCRIPTION	PART NUMBER FOR LIMED OAK CABINET Sears Cat. No. 1018
T42-509	Cabinet, wood, table	T42-521
T44-20	Baffle, wood	T44-20
T52-368	Knob—"Volume" control	T52-364
T52-369	Knob—"Tone" control	T52-365
T52-370	Knob—"Tuning" control	T52-366
T52-371	Knob—"Phono-Radio-Off" control	T52-367
T67-565	Dial Scale Plate	T67-565
T58-88	Pointer—Lucite	T58-88
T83-748	Back, cabinet	T83-748
T98-23	Grille cloth-cabinet	T98-32
T98-24	Grille cloth-speaker	T98-33
T71-57	Button, pointer	T71-57
T37-136	Cover, insulator, dial lamp	T37-136
T71-56	Shield, dial light	T71-56
T86-164	Washer, plate (cabinet base) (3)	T86-164
T97-134	Screw (6) No. 5x3/8 lg. bronze or blued	T97-134





D100-575

FIG. 4. SCHEMATIC DIAGRAM FOR CHASSIS 528.210-2

NOTES
VALUES OF CAPACITORS IN MFD. UNLESS OTHERWISE SPECIFIED.

ALL RESISTORS 1/2 WATT UNLESS OTHERWISE SPECIFIED.

(* THESE CAPACITORS ARE IN CERAMIC UNIT PART NO. T17-104.

VOLTAGES MEASURED FROM POINT INDICATED TO COMMON GROUND WITH 20,000 OHM/VOLT VOLTMETER, RADIO-PHONO SWITCH IN RADIO POSITION, LINE VOLTAGE SET AT 117 V.A.C.

MODELS 3001,
3002, Ch. 132.054

Specifications

Power Supply

105-125 Volts, AC-DC, 30 Watts

Frequency Range

Broadcast 540-1600 Kc.

Power Output

Undistorted 0.8 Watts

Maximum 1.5 Watts

Speaker Voice Coil Impedance 3.2 ohms

TECHNICAL INFORMATION FOR SERVICE MEN.

Tuning range 540-1600 Kc. Intermediate frequency -455 Kc. Measurements at 500 milliwatts output - approximately 1.26 volt on a rectifier type voltmeter connected across the voice coil. Dummy load for I-F. .05 ufd capacitor in series with generator lead. For R-F, 50 uufd capacitor in series with generator lead. Connect generator ground to receiver floating ground.

ALIGNMENT DATA

Position of Variable	Frequency of Generator	Dummy Antenna	Generator Output Lead	Adjust Trimmer For Maximum	Trimmer Function
Open	455 Kc.	.05 uf	Pin 7 of 12BE6	A1, A2	I. F.
Open	1720 Kc.	50 uuf	Ant. Coil*	A3	Oscillator
1400 Kc.**	1400 Kc.	50 uuf	Ant. Coil*	A4	Antenna
600 Kc.	600 Kc.	50 uuf	Ant. Coil*	Antenna Section Plate	Check Point

NOTES: * Disconnect hank during alignment.

** "A Rocking In" type of tuning is necessary while adjusting A3.
(See RL 562).

Approximate inputs for 500 MW output: I-F, 300 uv. R-F at 1400 Kc., 780 uv, at 1000 Kc., 960 uv. at 600 Kc., 1380 uv.

CAUTION: Remove the electric or power cord from the wall of floor outlet before replacing tubes, removing, adjusting, or cleaning the chassis, or while connecting an antenna.

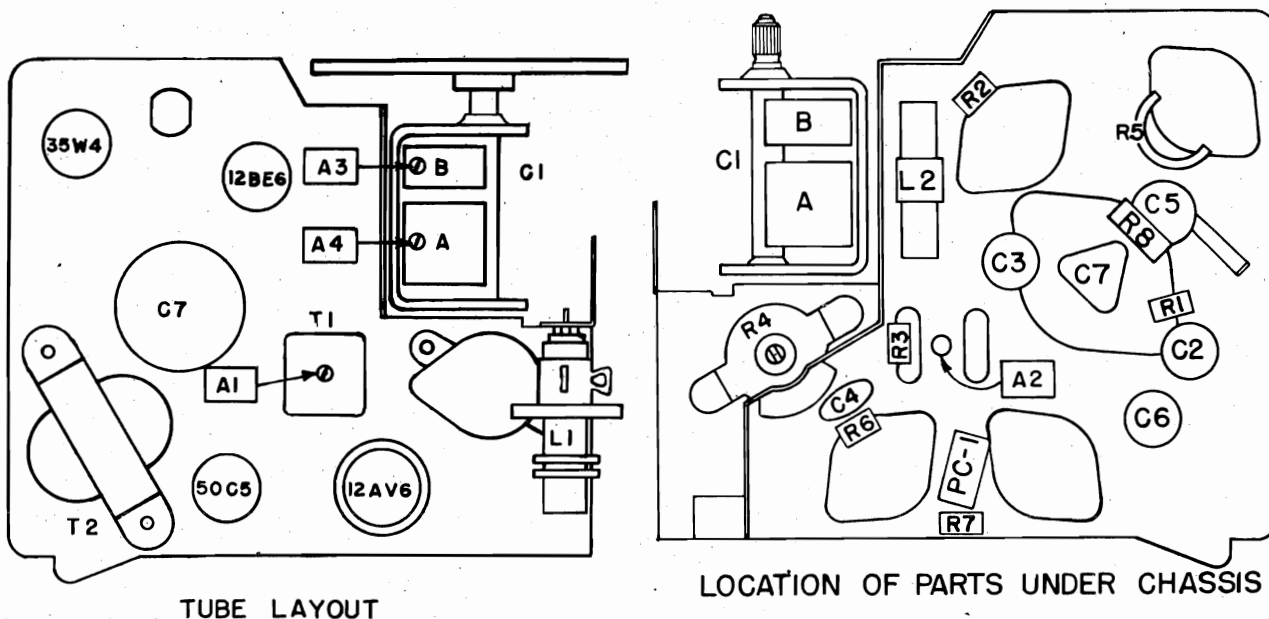

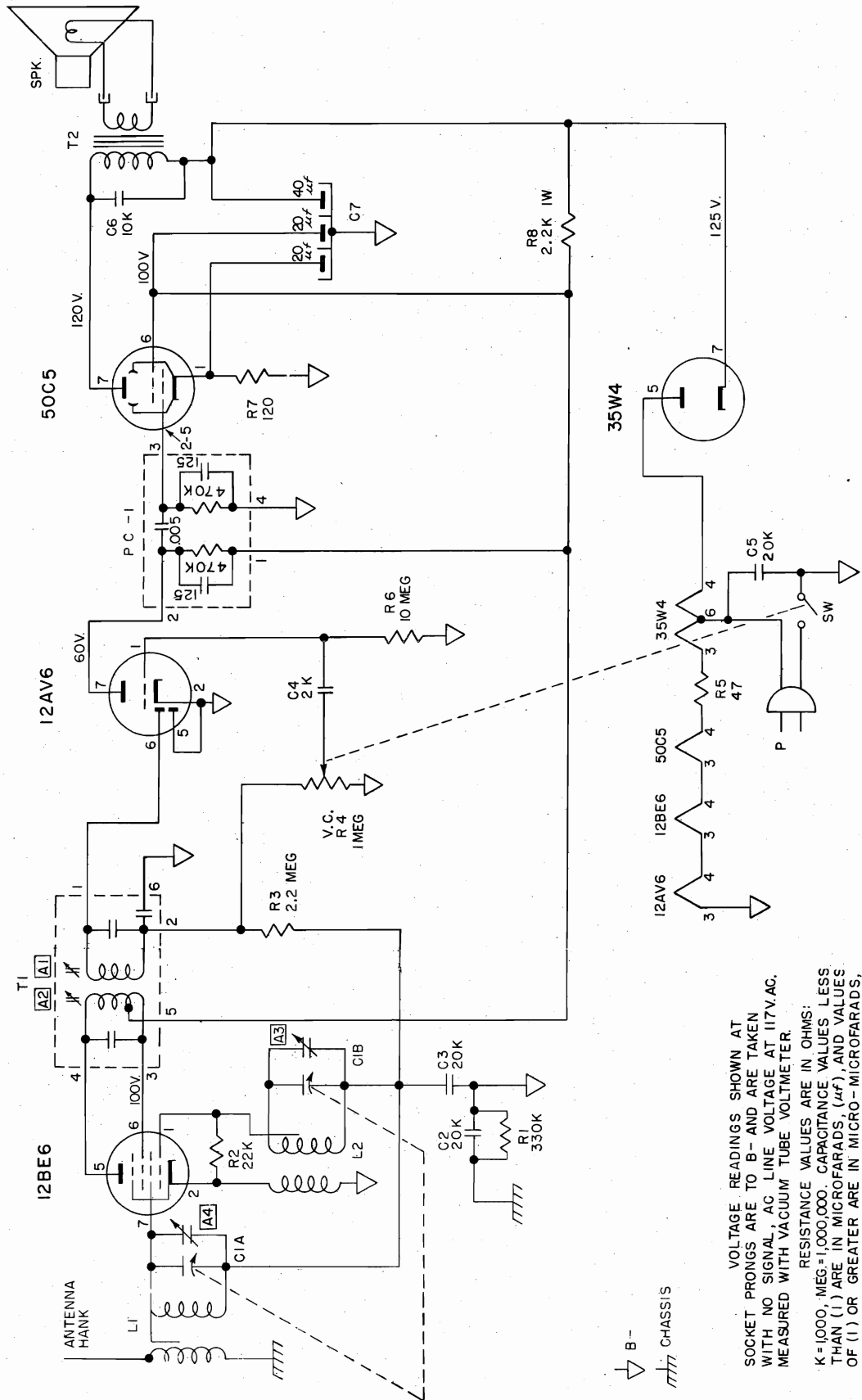

VOLTAGE READINGS SHOWN AT SOCKET PRONGS ARE TO B- AND ARE TAKEN WITH NO SIGNAL, AC LINE VOLTAGE AT 117V.AC. MEASURED WITH VACUUM TUBE VOLTMETER.

RESISTANCE VALUES ARE IN OHMS: K=1,000, MEG=1,000,000. CAPACITANCE VALUES LESS THAN (1) ARE IN MICROFARADS. (μ f), AND VALUES OF (1) OR GREATER ARE IN MICRO-MICROFARADS, ($\mu\mu$ f), UNLESS OTHERWISE INDICATED.

MODELS 3001,
3002, Ch. 132.054

HOW TO ORDER PARTS

1. Use Correct Order Form.
2. On the Purchase Order, always give the following information.
 - (1) PART NUMBER (number printed on the part if different from that shown in this list) and DESCRIPTION for each part ordered. When no part number is assigned, order by description and rating. Also give PRICE of part (indicate if no selling).
 - (2) THE CHASSIS NUMBER, which is 132.054. This number is found on a metal plate at the rear of the chassis.

PARTS LIST

<u>Schematic Location</u>	<u>Part No.</u>	<u>Description</u>	<u>List</u>
<u>Capacitors</u>			
C1A, B	N41089	Capacitor, Variable	2.85
C2, C3, C5		Capacitor, Disc. .02 uf	.23
C4		Capacitor, Disc. .002 uf	.23
C6		Capacitor, Disc. .01 uf	.23
C7	N41102	Capacitor, Electrolytic 40-20 uf 150V, 20 uf, 25V.	2.30
<u>Resistors</u>			
R1		Resistor, 330K ohm, 1/2W, 20%	.15
R2		Resistor, 22000 ohm, 1/2W, 20%	.15
R3		Resistor, 2.2 meg., 1/2W, 20%	.15
R5		Resistor, 47 ohm, 1W, 10%	.15
R6		Resistor, 10 meg, 1/2W, 20%	.15
R7		Resistor, 120 ohm, 1/2W 10%	.15
R8		Resistor, 2200 ohm, 1W, 10%	.15
<u>Chokes, Coils & Transformers</u>			
L1	N22864-1	Coil, Antenna Assy.	1.00
L2	N41106-1	Coil, Oscillator Assy.	.50
T1	N41168-2	Coil, I.F. Assy.	1.55
T2	N41119-1	Transformer, Output Assy.	1.30
<u>Miscellaneous</u>			
PC-1	N25264	Printed Circuit(Centralab PC 70)	.57
	N41223-1	Grill Backing Assy.	.85
	N41110	Leaflet, Instruction	.20
	N22875	Speaker 4" P.M.	3.08
	N25781-1	Silvertone Name Plate	.43
R4	N41022	Volume Control 1 meg.	1.15
	N41519-1	Cabinet (Brown)	2.85
	N41519-2	Cabinet (Ivory)	3.25
	N41087-1	Knob, Volume (Ivory 3001)	.15
	N41087-2	Knob, Volume (Red 3002)	.15
	N41095-1	Knob, Dial (Ivory 3001)	.43
	N41095-2	Knob, Dial (Red 3002)	.43

MODELS 345P,
1U-345P**POWER SUPPLY****THIS RADIO CAN BE OPERATED ON EITHER:**

110 to 120 VOLTS DIRECT CURRENT
OR
110 to 120 VOLTS, 50 to 60 CYCLE, ALTERNATING CURRENT
OR
BATTERIES—WITH ONE 4½ VOLT "A" and ONE 90 VOLT "B"

LOOP AERIAL

This radio has a built-in rod antenna. Rod antennas are directional, therefore the volume of a weak station may be improved, or electrical noise may be reduced, by lifting and turning the radio to a different position after the station is tuned in. A trial will reveal position of best reception.

INSTALLATION OF REQUIRED BATTERIES

Diagram shows proper location and connections of the following required types of batteries:

One 4½ Volt "A" Battery, such as Eveready 746A, or Ray-O-Vac P83A or Eveready No. 736A, or equivalent.

One 90 Volt "B" Battery, such as Eveready Type No. 490B or equivalent.

TO INSTALL BATTERIES, GENTLY OPEN CABINET BACK AND CONNECT AND PLACE BATTERIES IN EXACT POSITION SHOWN ON THE DIAGRAM, THEN CLOSE BACK. BE CAREFUL NOT TO INJURE ANY OF THE EXPOSED RADIO PARTS.

BATTERY OPERATION

- (A) Open cabinet back.
- (B) Insert plug on end of radio line cord into the AC-DC receptacle as shown on the above diagram.
- (C) Be sure to fold excess line cord and place on top and to the right of the receptacle before closing back.

ELECTRIC OPERATION

To operate the receiver on 110 to 120 Volt Direct Current, or 110 to 120 Volt, 50 to 60 cycle Alternating Current:

- (A) Open cabinet back and take line cord out.
- (B) Place the cord in notch in cabinet, CLOSE BACK, and insert plug into 110 to 120 Volt AC or DC electric power outlet.

**SPECIAL INSTRUCTIONS FOR
"DIRECT CURRENT" OPERATION**

If the current supply is DIRECT CURRENT, and the radio does not play after it has been turned on for approximately one minute, simply reverse radio power cord plug in electric power receptacle.

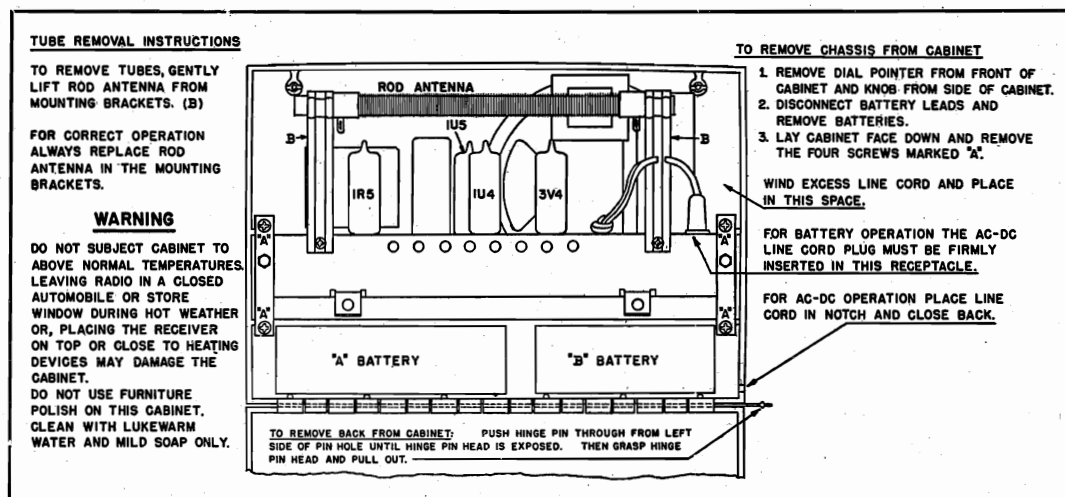

MODELS 345P,
1U-345P

ALIGNMENT PROCEDURE

Be sure to follow procedure carefully and in the order given—otherwise the receiver will be insensitive and the dial calibration incorrect. For alignment procedure, read tabulations from left to right. Make the adjustment marked (1) first, (2) next, (3) third.

IF RADIO HAS METAL PLATE ON BOTTOM OF CHASSIS BE SURE TO HAVE PLATE MOUNTED ON CHASSIS WHEN ALIGNING SET IN STEPS 2 AND 3.

Before starting alignment:

- (A) Use an accurately calibrated test oscillator with some type of output measuring device.
- (B) **WHEN ADJUSTING THE 1660 KC OSCILLATOR TRIMMER** connect the high side of the test oscillator to the connection on the antenna rod closest to the tuning condenser. Connect the low side of the test oscillator to common negative.
- (C) **THE 1400 KC ANTENNA TRIMMER** should be adjusted only after all other adjustments have been made. When aligning the 1400 KC Antenna Trimmer, couple test oscillator to receiver by: (1) make loop consisting of five to ten turns of No. 20 to No. 30 size wire, wound on a 2" or 3" form; (2) connect this loop across output of test oscillator; (3) place test oscillator loop near radio antenna. **BE SURE THAT NEITHER LOOP NOR ANTENNA MOVES WHILE ALIGNING.**

IMPORTANT: WHEN ADJUSTING THE I.F. TRIMMERS USE A THIN NON-METALLIC SCREWDRIVER.

Steps	Set receiver dial to:	TEST OSCILLATOR			Refer to parts layout diagram for location of trimmers mentioned below:
		Adjust test oscillator frequency to:	Use dummy antenna in series with output of test oscillator consisting of:	Attach output of test oscillator to	
1	Any point where no interfering signal is received	Exactly 455 K. C.	0.2 Mfd. Condenser	High side to connection on antenna rod closest to the tuning condenser. Low side to common negative through a .02 MFD blocking condenser.	Adjust each of the 2nd I.F. transformer trimmer adjustment screws for maximum output, then adjust each of the 1st I.F. transformer trimmer adjustment screws for maximum output.
2	Rotate gang condenser to minimum capacity	Exactly 1660 K. C.	See paragraph (B) above	See paragraph (B) above	Adjust 1660 K. C. oscillator trimmer for maximum output.
3	Approximately 1400 K. C.	Approx. 1400 K. C.	See paragraph (C) above	See paragraph (C) above	Adjust 1400 K. C. antenna trimmer for maximum output.

MODELS 345P,
1U-345P

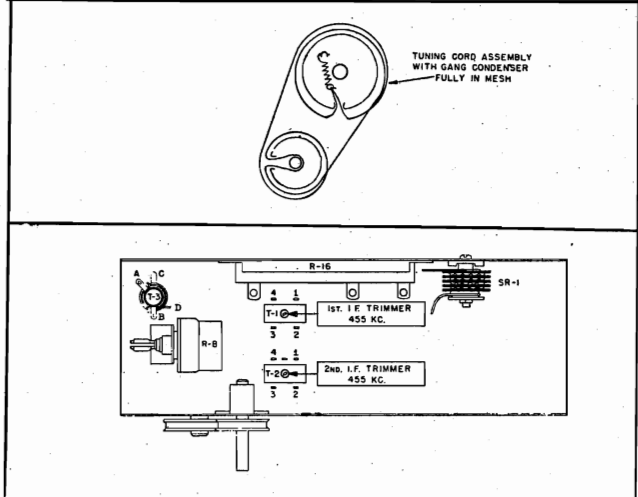
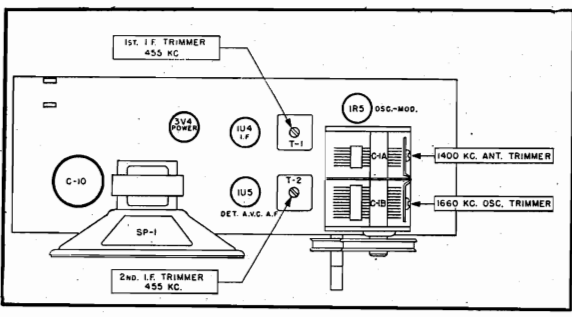
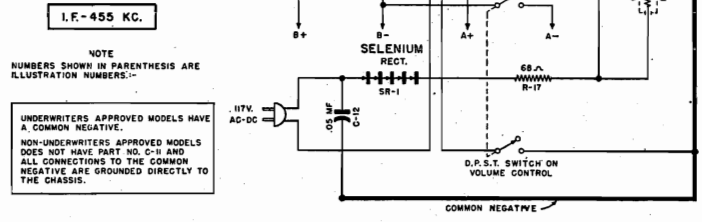
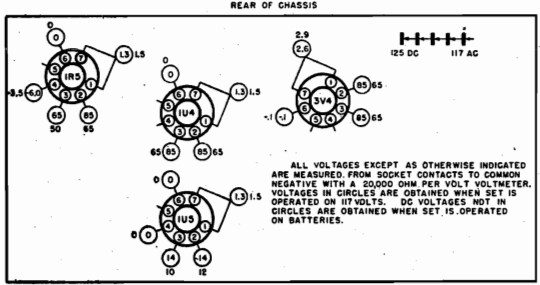
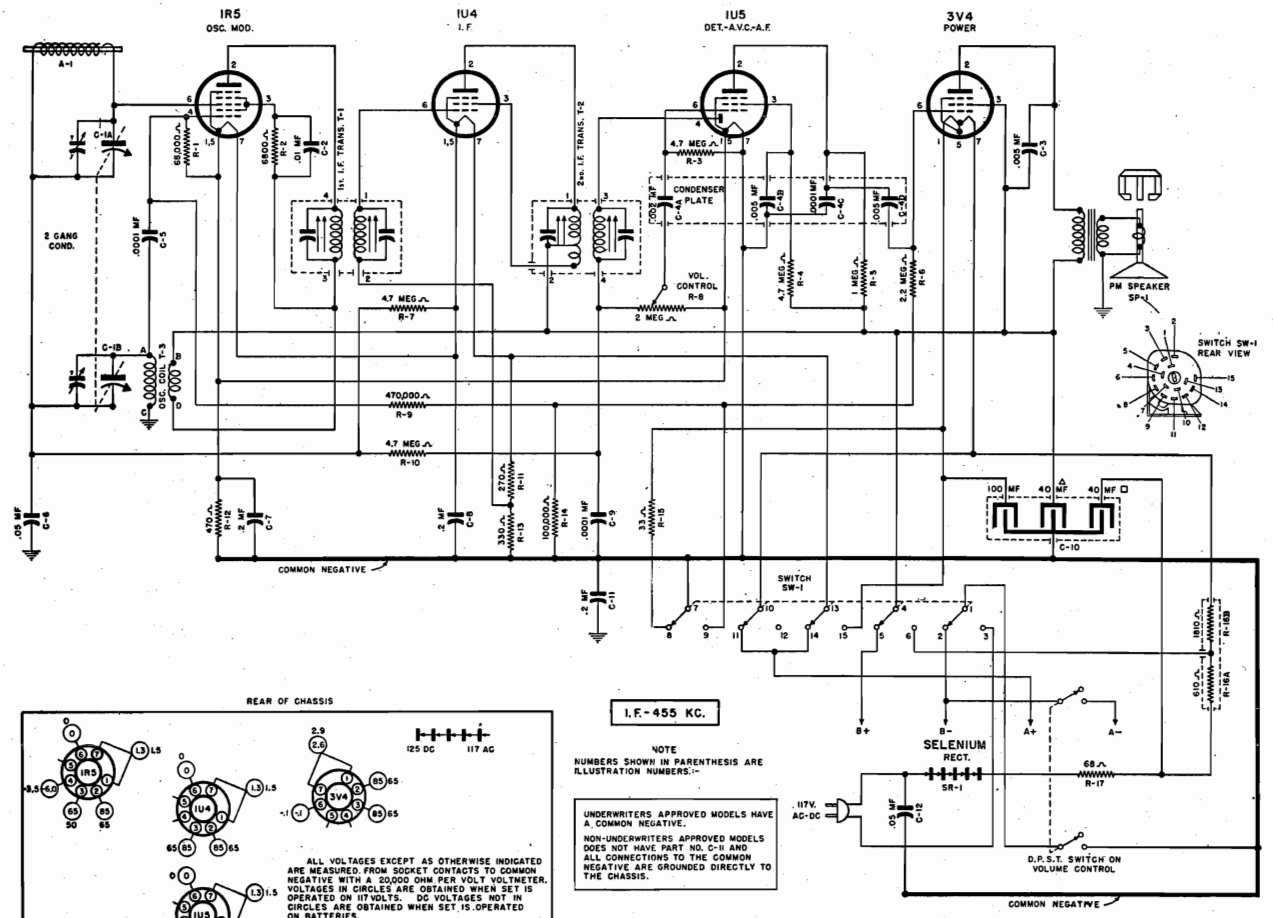

WARNING—neglected batteries may damage the radio—remove batteries from cabinet if your radio is operated on AC or DC current exclusively or if the radio is to stand unused for a long period of time.

IMPORTANT— do not leave run-down batteries in your radio. Remove them immediately.

**MODELS 345P,
1U-345P**

Illus. No.	DESCRIPTION	Part No.	List Price
R-3	Carbon, 4.7 Megohm 1/3 W	27E475	.07
R-4	Carbon, 4.7 Megohm 1/3 W	27E475	.07
R-5	Carbon, 1 Megohm 1/3 W	27E105	.07
R-6	Carbon, 2.2 Megohm 1/3 W	27E225	.08
R-7	Carbon, 4.7 Megohm 1/3 W	27E475	.07
R-8	Control, Volume with D.P.S.T. Switch, 2 Megohm	28E83	1.32
R-9	Carbon, 470,000 Ohm 1/3 W	27E474	.09
R-10	Carbon, 4.7 Megohm 1/3 W	27E475	.07
R-11	Carbon, 270 Ohm 1/3 W	27E271	.09
R-12	Carbon, 470 Ohm 1/3 W	27E471	.09
R-13	Carbon, 330 Ohm 1/3 W	27E331	.09
R-14	Carbon, 100,000 Ohm 1/3 W	27E104	.07
R-15	Carbon, 33 Ohm 1/2 W	27E330-2	.08
R-16A	Wire Wound, 1810 and 610 Ohms 8 W	27E1005	1.04
R-16B	Carbon, 68 Ohm 1 W	27E680-3	.08
T-1	1st I.F. Transformer	20E742	1.67
T-2	2nd I.F. Transformer	20E743	1.89
T-3	Coil, Oscillator	20E744	.93

COILS AND TRANSFORMERS

IMPORTANT: When ordering complete cabinet, or cabinet parts, BE SURE TO MENTION REQUIRED COLOR in addition to proper part number.

MISCELLANEOUS PARTS

Illus. No.	DESCRIPTION	Part No.	List Price
C-1A	Variable (2 Gang)	24E59	\$2.81
C-2	Fixed Ceramic, .01 MFD (Disc)	23E2025-4	.24
C-3	Fixed Ceramic, .005 MFD (Disc)	23E2025	.31
C-4A	Ceramic Capacitor Plate	23E2024	.75
C-4B	Fixed Ceramic, .0001 MFD	23E24	.21
C-4C	Tubular, .05 MFD 200 V	23E216	.24
C-4D	Tubular, .2 MFD 200 V	23E220	.40
C-5	Tubular, .2 MFD 200 V	23E220	.40
C-6	Fixed Ceramic, .0001 MFD	23E24	.21
C-7	Dry Electrolytic, 40-40 MFD, 150 V, 100 MFD, 10 V	23E29	2.07
C-8	Tubular, .2 MFD 400 V (1U Models Only)	23E2021	.35
C-9	Tubular, .05 MFD 400 V	23E416	.28
R-1	Carbon, 68,000 Ohm 1/3 W	27E683	.08
R-2	Carbon, 6800 Ohm 1/3 W	27E682	.08
A-1	Antenna	64E36	2.01
Sp-1	Speaker P.M.	1E29-2	8.07
SR-1	Selenium Rectifier	57E14	2.10
SW-1	Switch, Change-Over	29E20	1.27
20E747	Complete Cabinet Assembly with Handle and Cabinet Back, Walnut	20E747	12.16
20E748	Cabinet Front Assembly With Handle (Walnut)	20E748	8.70
7E314	Cabinet Back, Walnut	7E314	2.19
52E89	Cabinet Handle, Walnut	52E89	.30
37E73-3	Volume Knob, Walnut	37E73-3	.10
20E747-2	Complete Cabinet Assembly with Handle and Cabinet Back, Green	20E747-2	12.16
20E748-2	Cabinet Front Assembly with Handle, Green	20E748-2	8.70
7E314-2	Cabinet Back, Green	7E314-2	2.19
52E89-2	Cabinet Handle, Green	52E89-2	.30
37E73-4	Volume Knob, Green	37E73-4	.10
20E747-3	Complete Cabinet Assembly with Handle and Back, Ivory	20E747-3	12.16
20E748-3	Cabinet Front Assembly with Handle, Ivory	20E748-3	8.70
7E314-3	Cabinet Back, Ivory	7E314-3	2.19
52E89-3	Cabinet Handle, Black	52E89-3	.30
37E73-5	Volume Knob, Ivory	37E73-5	.10
20E747-4	Complete Cabinet Assembly with Handle and Back, Maroon	20E747-4	12.16
20E748-4	Cabinet Front Assembly with Handle, Maroon	20E748-4	8.70
7E314-4	Cabinet Back, Maroon	7E314-4	2.19
52E89-4	Cabinet Handle, Maroon	52E89-4	.30
37E73-6	Volume Knob, Maroon	37E73-6	.10
20E747-5	Complete Cabinet Assembly with Handle and Back, Black	20E747-5	13.49
20E748-5	Cabinet Front Assembly with Handle, Black	20E748-5	9.22
7E314-5	Cabinet Back, Black	7E314-5	2.70
52E89-3	Cabinet Handle, Black	52E89-3	.30
37E73-7	Volume Knob, Black	37E73-7	.10
20E747-6	Complete Cabinet Assembly with Handle and Back, Yellow	20E747-6	13.49
20E748-6	Cabinet Front Assembly with Handle, Yellow	20E748-6	9.22
7E314-6	Cabinet Back, Yellow	7E314-6	2.70
52E89-3	Cabinet Handle, Black	52E89-3	.30
37E73-8	Volume Knob, Yellow	37E73-8	.10
35E33	Dial Indicator Knob	35E33	1.05
20E741	Dial Drive Shaft Assembly	20E741	.40
20E745	Dial Drive Cord Assembly	20E745	.16
65E2	Dial Drive Cord Tension Spring	65E2	.06
41E4	Line Cord with Plug	41E4	.58
20E249	B- Battery Connector	20E249	.35
20E249-2	B+ Battery Connector	20E249-2	.35
20E340-3	A Battery Connector	20E340-3	.23
13E103-20	Cabinet Back Catch	13E103-20	2.79/c
15E239	Handle Bracket	15E239	.78
46E21	Chassis Mounting Strap	46E21	.05
47E13-3	Hinge Pin	47E13-3	.07
55E60	Strap for Handle	55E60	.13
15E238	Antenna Mfg. Bracket	15E238	.51

MODELS 343,
1U-343

VOLTAGE RATING

THIS RADIO IS DESIGNED FOR USE ON EITHER:
110-120 VOLTS 50-60 CYCLES ALTERNATING CURRENT (AC)

OR

110-120 VOLTS DIRECT CURRENT (DC)

SPECIAL INSTRUCTIONS FOR "DIRECT CURRENT" OPERATION:

If the current supply is DIRECT CURRENT, and the radio does not play after it has been turned on for approximately one minute, simply reverse radio power cord plug in electric power receptacle.

LOOP AERIAL

THE LOOP AERIAL SUPPLIED with the radio should provide ample reception in average locations.

Loop aerials are directional—the volume of a weak station may be

improved, or undesired electrical noise may be reduced, by lifting and turning the radio to a different position. A trial will reveal position of best reception with least interference.

FUNCTION OF CONTROLS ON RADIO

THE LEFT HAND KNOB controls the volume control and off-and-on switch.

THE RIGHT HAND KNOB is the station selector.

OPERATING INSTRUCTIONS

PLACE VOLUME CONTROL KNOB IN one-half to maximum volume position.

TURN TUNING CONTROL KNOB until the desired station is heard with greatest volume and clearest tone.

ALIGNMENT PROCEDURE

For alignment procedure read tabulations from left to right, and make the adjustment marked (1) first, (2) next, (3) third. Before starting alignment:

- (A) Check tuning dial adjustment by tuning gang condenser until plates touch maximum capacity stop (completely in mesh) at which point the dial needle must be exactly even with the last line at the low frequency end of the dial calibration. If dial needle does not point exactly to last line move to correct position.
- (B) Use an accurately calibrated test oscillator with some type of output measuring device.
- (C) WHEN ADJUSTING THE 1650 KC OSCILLATOR TRIMMER, remove chassis from cabinet and disconnect the loop connection wires from the loop. Attach a 1 megohm resistor across these connections and feed output of test oscillator across the 1 megohm resistor.
- (D) THE 1400 KC LOOP ANTENNA TRIMMER should be adjusted only after all other adjustments have been made. PLACE LOOP ANTENNA IN THE SAME POSITION IT WILL BE IN WHEN THE SET IS IN THE CABINET — APPROXIMATELY $\frac{5}{8}$ " SPACE BETWEEN LOOP AND CHASSIS.

When aligning the 1400 KC Antenna Trimmer, couple test oscillator to receiver loop by: (1) make loop consisting of five to ten turns of No. 20 to No. 30 size wire, wound on a 2" or 3" form; (2) connect this loop across output of test oscillator; (3) place test oscillator loop near radio loop. BE SURE THAT NEITHER LOOP MOVES WHILE ALIGNING.

MODELS 343,
1U-343

TEST OSCILLATOR			
Steps	Set receiver dial to:	Adjust test oscillator frequency to:	Use dummy antenna in series with output of test oscillator consisting of:
1	Any point where no interfering signal is received.	455 K. C.	.02 MFD. condenser
2	Exactly 1650 K. C.	Exactly 1650 K. C.	See paragraph (C) above
3	Approx. 1400 K. C.	Approx. 1400 K. C.	See paragraph (D) above

Refer to parts layout diagram for location of trimmers mentioned below:

Adjust each of the second I.F. transformer trimmers for maximum output— then adjust each of the first I.F. trimmers for maximum output.

Adjust 1650 K. C. oscillator trimmer for maximum output.

Adjust 1400 K. C. antenna trimmer for maximum output.

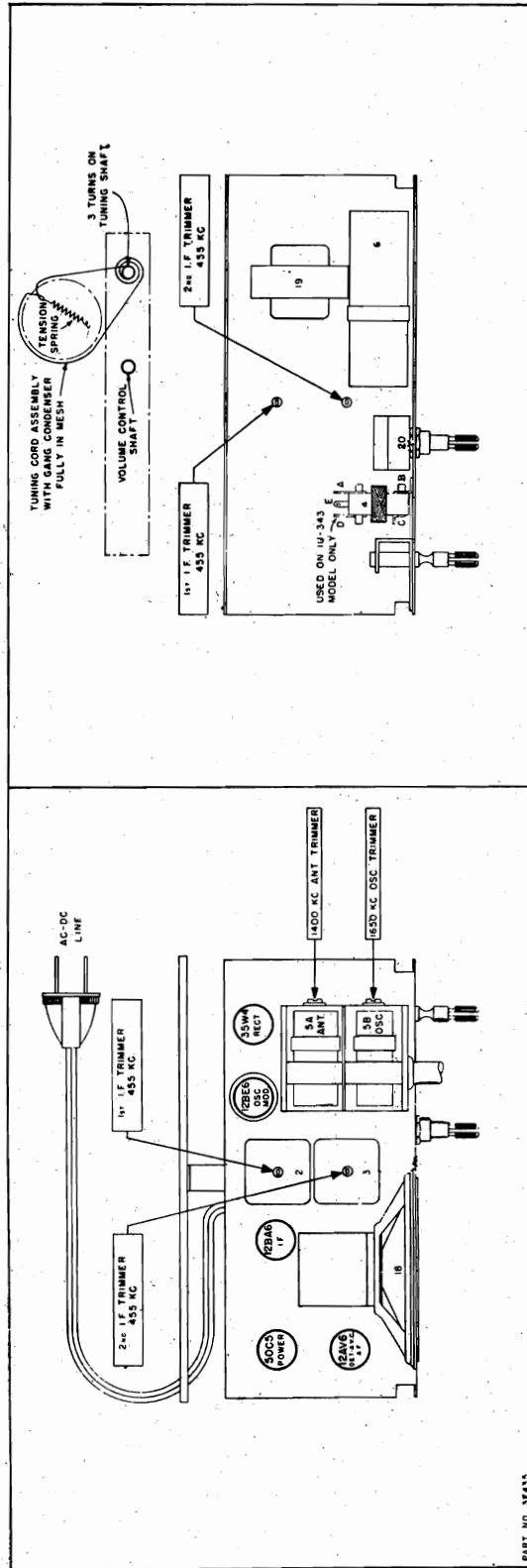

PART NO. 3F433

TO SERVICE TUBES, it is necessary to remove the cabinet back, and detach the two leads from the loop.

Before remounting the back on the cabinet, be sure to properly re-connect these leads. The green-white wire must be attached to the terminal which has the word "GREEN" printed close to it.

TO REMOVE CHASSIS FROM CABINET:

(A) Remove cabinet back.

(B) Unscrew the two screws holding the chassis to the rear of the cabinet.

(C) Remove pointer by gently pulling it away from cabinet.

(D) Pull knobs off of control shafts.

(E) Unscrew and remove hex nut on volume control shaft—accessible when knob is removed.

(F) Slide Chassis out of cabinet.

TO REINSTALL, reverse the above procedure. DO NOT tighten nut too much—otherwise, cabinet may crack.

PARTS LIST

Illus. No.	Part No.	Part Name	Description	List Price
1	7E304	Antenna	Loop and cabinet back.	\$1.10
2	20E732	Coil	1st I. F. Transformer.	1.75
3	20E732	Coil	2nd I. F. Transformer.	1.75
4	20E767	Coil	Oscillator	1.08
4	20E772	Coil	Oscillator (used in 1U343 only)	
5	24E45	Condenser	Two Gang, Tuning	3.05
6	24E24	Condenser	Dry Electrolytic, 50-50 Mfd. 150 Volt	1.09
7	23E2041-2	Condenser	Ceramic, Coupling Plate.	.92
8	23E2027	Condenser	Ceramic, .00025 Mfd. 500 V.	.29
9	23E411	Condenser	Tubular, .01 Mfd. 400 V.	.21
10	23E211	Condenser	Tubular, .01 Mfd. 200 V.	.24
11	23E216	Condenser	Tubular, .05 Mfd. 200 V.	.24
12	23E416	Condenser	Tubular, .05 Mfd. 400 V.	.28
			IMPORTANT: When ordering complete cabinet or cabinet parts, be sure to mention required color in addition to part number.	
			Carbon, 150 Ohm, 1/3 W.	.09
			Carbon, 2200 Ohm, 2 W.	.21
			Carbon, 22,000 Ohm, 1/3 W.	.09
			Carbon, 3.3 Megohm, 1/3 W.	.08
			Carbon, 3.3 Megohm, 1/3 W.	.08
			3 1/2" P.M.	4.31
			Output	1.15
			500,000 Ohm, with Switch	1.09
			Ceramic, .00025 Mfd. 500 V. (used in 1U343 only)	.29
			Carbon, 1 Megohm, 1/3 W. (used in 1U343 only)	.07
			Tubular, .2 Mfd. 400 V. (used in 1U343 only)	.35

MISCELLANEOUS PARTS

Part No.	Part Name	Description	List Price
7E302-2	Cabinet	Walnut Plastic	\$5.40
7E302-3	Cabinet	Ivory Plastic	7.40
7E302-4	Cabinet	Red Plastic	6.20
41E13	Line Cord	5 Ft. Rubber Line Cord	.46
20E253-25	Dial Cord	Dial Drive Cord	.17
20E348-3	Dial Shaft Assembly	Dial Drive Shaft with Bracket	.58
35E31-2	Dial Pointer	Dial Indicator for Walnut Cabinet	.63
35E31-3	Dial Pointer	Dial Indicator for Ivory Cabinet	.63
35E31-4	Dial Pointer	Dial Indicator for Red Cabinet	.66
33E99	Pointer Insulator	Plastic, used to mount and insulate Pointer from Chassis	.84
13E103-8	Pointer Tension Clip	Tension Spring for 33E99 Pointer Insulator	2.84/C
65E2	Dial Spring Knob	Tension Spring for Dial Cord	.06
37E75	Knob	For Walnut Cabinet	.11
37E75-2	Knob	For Ivory and Red Cabinet	.11
7E303	Baffle	Baffle Assembly with Grille Cloth	.64
19E34	Nut	Hex Head, used to hold Chassis to Cabinet	.18

PRICES SUBJECT TO CHANGE WITHOUT NOTICE

Above Prices Effective 6-1-52

Printed 6-52

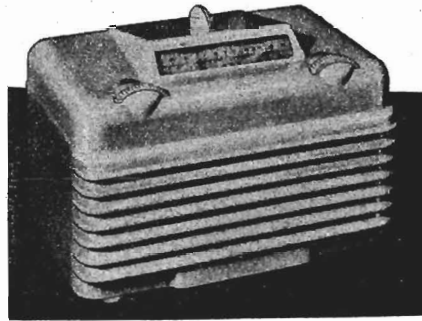

SPECIFICATIONS:

- Cabinet colors: Ivory and Walnut
- Short wave: 6-20 Megacycles
- Standard Broadcast: 535-1650 Kilocycles
- 115 Volt AC DC
- Full 5" P.M. Dynamic Speaker
- Improved filtering for hum-free reception (Equipped with sealed "long life" filter condenser)
- Automatic volume control
- Large built-in loop antenna
- External Antenna connections
- Tubes: 1-12BE6, 1-12BA6, 1-12AV6, 1-50C5
- 1-35W4 Rectifier

IF ALIGNMENT- 456 KC (Connect to antenna connector on loop).
Align S. W. antenna coil at 17 MC. Bend gang capacitor plates for tracking at 7 MC.
Align B. C. loop antenna at 1400 KC.
Adjust oscillator padder at 600 KC.
Dial pointer alignment-538 KC. with fully closed capacitor..

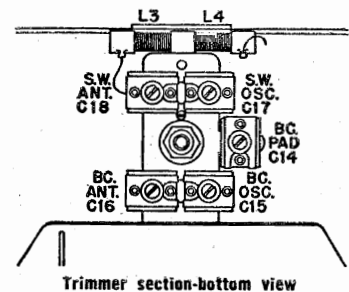
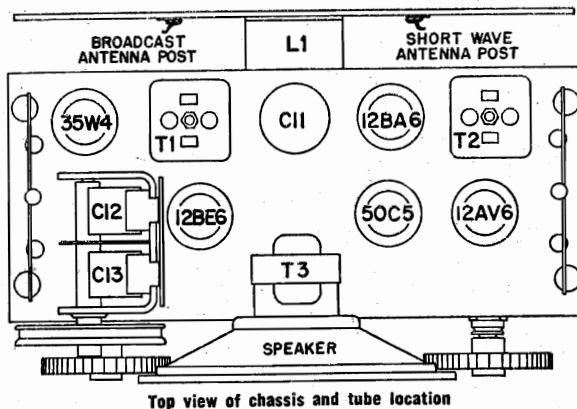

MODEL X13

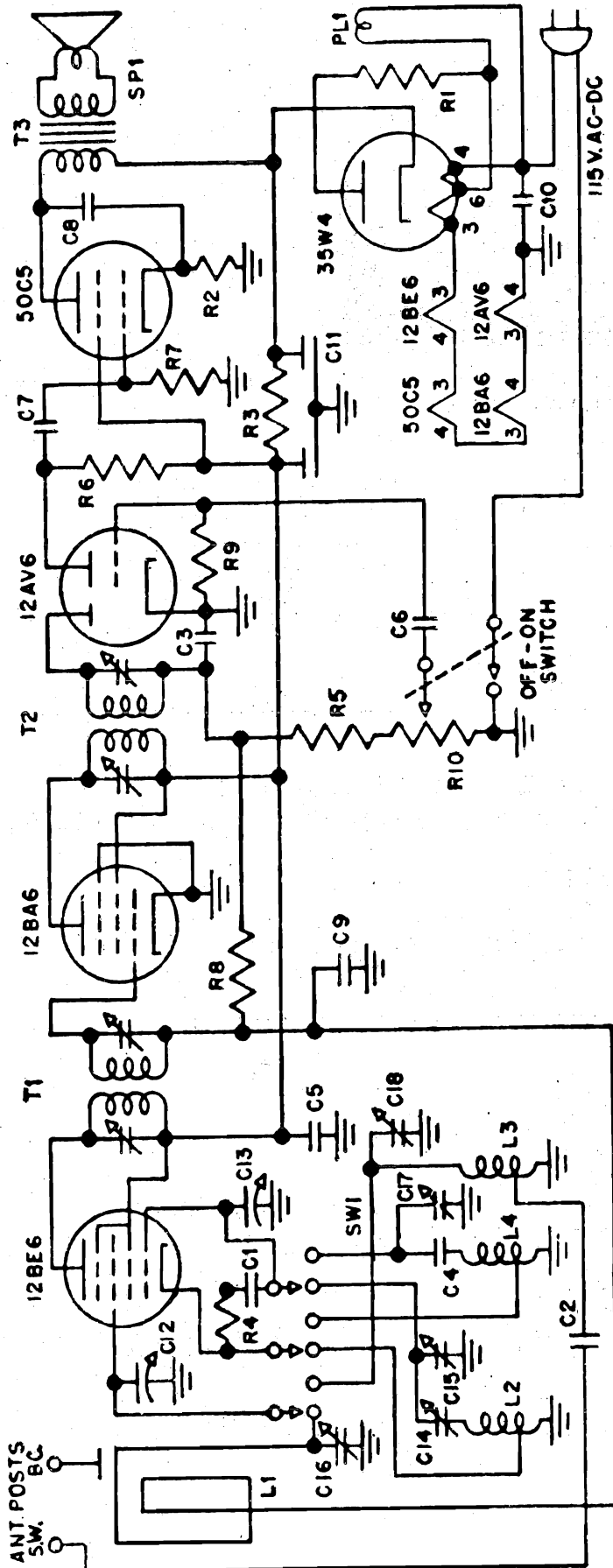

- R 1 - 24 OHM 1/2 WATT RESISTOR
- R 2 - 180 " " " " " "
- R 3 - 1200 " " " " " "
- R 4 - 22K " " " " " "
- R 5 - 22K " " " " " "
- R 6 - 470K " " " " " "
- R 7 - 1 MEGOHM " " " " " "
- R 8 - 2.2 " " " " " "
- R 9 - 4.7 " " " " " "
- R10 - 500K OHM POT. WITH SWITCH
- C 1 - 100 MMF MICA OR DISC 500V. CAPACITOR
- C 2 - SAME AS C1
- C 3 - 250 MMF MICA OR DISC-500V. CAPACITOR
- C 4 - .0047MFD MICA-TOL. 5% " " " "
- C 5 - .01 MFD CERAMIC DISC. " " " "
- C 6 - .01 " " " " " "
- C 7 - .01 " " " " " "
- C 8 - .01 " " " " " "
- C 9 - .047 MFD MOLDED TUBULAR-400V. " " " "
- C10 - .047 " " " " " "
- C11 - 50+50MFD ELECTROLYTIC-150V. " " " "
- C12 & C13 - GANG CAPACITOR
- C14 - 100-580 MMF PADDER CAPACITOR
- C15 - 3-30MMF TRIMMER CAPACITOR
- C16 - 3-30 " " " "
- C17 - 3-30MMF TRIMMER CAPACITOR
- C18 - 3-30 " " " "
- L 1 - LOOP ANTENNA NO. X13
- L 2 - OSCILLATOR COIL B.C. NO. 416-C
- L 3 - ANTENNA COIL S.W. NO. X13
- L 4 - OSCILLATOR COIL S.W.
- T 1 - 455 K.C. IF. COIL-NO. 298
- T 2 - 455 K.C. IF. COIL-NO. 298
- T 3 - OUTPUT TRANSFORMER NO. 416A
- PL1 - NO. 44 PILOT LIGHT
- SPEAKER - 5" RM. SPEAKER
- SW1 - 3 POLE-2 POSITION SWITCH

Schematic Diagram Model X13

INSTALLATION AND OPERATION INSTRUCTION

for

SUPERHETERODYNE RADIO RECEIVER

Model No. 389 Mahogany

Model No. 390 White

CONNECTING THE SET

POWER SUPPLY This receiver is designed to operate on any alternating current supply (AC) ranging from 110 to 120 volts, 50 to 60 cycles; or on any direct current supply (DC) ranging from 110 to 120 volts.

SPECIAL INSTRUCTIONS FOR DC OPERATION When operating from a DC (direct current) power supply it may be necessary to reverse the power cord plug in the wall socket before the receiver will function, due to the polarity condition of a direct current supply. If the receiver fails to perform after being turned on one minute, simply reverse the power plug.

GROUND No ground connection should be used when operating this receiver. The receiver gets its ground connection through the power line and any external connection to the chassis may cause a short circuit and consequent damage.

CAUTION: Do not place receiver on hot objects such as stoves, radiators, etc. Heat will damage the internal components of the receiver.

CONTROLS AND OPERATION

LEFT HAND KNOB (Manual Volume Control and "On-Off" Switch). Turn this knob to the extreme right. Wait about a minute for tubes to become heated. When signal comes in adjust volume as desired.

RIGHT HAND KNOB (Station Selector). Move the knob over a narrow range of the dial at a point where the desired station is located until the station is received with maximum volume; then readjust the volume control to the proper level. Never use the station selector to adjust the volume as this practice results in distorted tone quality and deficient bass response. The Volume Control only is to be used for this purpose. For maximum clarity the indicator should be adjusted to the center of the area covered by the station being tuned.

TUNING RANGE

This receiver is designed to operate over the standard broadcast band which extends from 535 to 1620 Kilocycles (KC).

AERIAL SYSTEM

This receiver has a built-in "loop" aerial. Its excellent design is such as to increase pick-up from stations having wide variations in signal strength. The efficiency and selectivity of the loop provide outstanding reception without the use of an external aerial. The "loop" aerial used on this receiver is somewhat directional so reception from weak stations can be improved by turning the set in the proper direction.

MODELS 389, 390

ALIGNMENT

Step No.	Position of Gang	Signal Generator Frequency	Generator Connection	Dummy Antenna	Adjustment	Type of Adjustment
1	Open	455 KC. 455 KC.	Rear Gang Terminal	.1 Mfd.	I.F. Slugs	Adjust for Maximum Output
2	Open	1620 KC.	Dummy Antenna	2 Turns of Hookup Wire 6" in Dia. (Place Approx. a Foot from & parallel to loop.)	Front Gang Trimmer	Adjust for Maximum Output
3	1400 KC.	1400 KC.			Rear Gang Trimmer	Adjust for Maximum Output
4	600 KC.	600 KC.				Check Gang Alignment

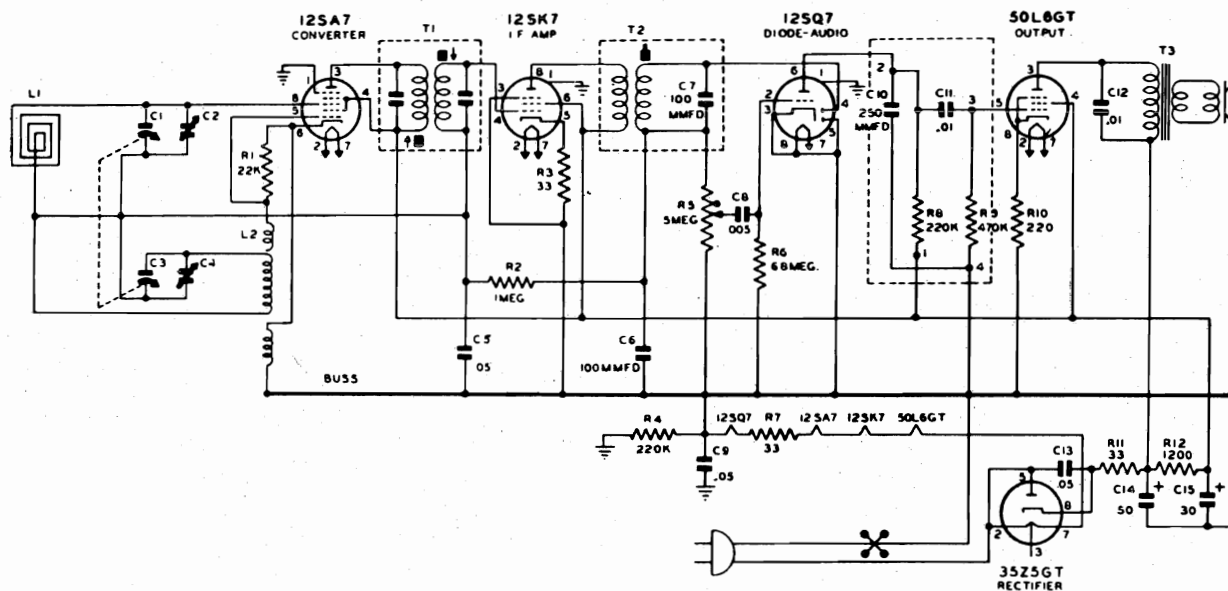

LLUS. NO.	PART NO.	PART NAME	DESCRIPTION
C1,C3	N-8745	Condenser	Gang Tuning with Pulley
C2,C4	--	Trimmers	Gang
C5,C9	N-1345	Condenser	Paper .05 MFD. 200 Volts
C6	N-6015	Condenser	Ceramic 100 MMFD. 500 V. 20%
C7	PART OF N-8150	Condenser	100 MMFD. 500 Volt 10%
C8	N-4894	Condenser	Paper .005 MFD. 600 Volts
*C10	N-6488	Condenser	Ceramic 259 MMFD. 500 V. 20%
*C11	N-1344	Condenser	Paper .01 MFD. 400 Volts
C12	N-1344	Condenser	Paper .01 MFD. 400 Volts
C13	N-1346	Condenser	Paper .05 MFD. 400 Volts
C14)	N-7889	Condenser	Electrolytic (50 MFD. 150 V.)
C15)			(30 MFD. 150 V.)

ILLUS. NO.	PART NO.	PART NAME	DESCRIPTION
R1	N-4025	Resistor	Carbon 22,000 Ohm 1/2W. 20%
R2	N-1262	Resistor	Carbon 1.0 Megohm 1/2W. 20%
R3,R11	N-4022	Resistor	Carbon 33 Ohm 1/2 Watt 20%
R4	N-4026	Resistor	Carbon 220,000 Ohm 1/2W. 20%
R5	N-8732	Volume Control	With Switch - 500,000 Ohms
R6	N-4028	Resistor	Carbon 6.8 Megohm 1/2W. 20%
R7	N-4068	Resistor	Carbon 33 Ohm 1.0 Watt 20%
*R8	N-4026	Resistor	Carbon 220,000 Ohm 1/2W. 20%
*R9	N-4027	Resistor	Carbon 470,000 Ohm 1/2W. 20%
R10	N-4024	Resistor	Carbon 220 Ohm 1/2 Watt 10%
T1	N-7981	Transformer	1ST I.F.
T2	N-8150	Transformer	2ND I.F.
	N-7824	Speaker	4" PM With Transformer
L1	N-8906	Coil	Loop Antenna & Cabinet Back
L2	N-8709	Coil	Oscillator

MODELS 241, 242,
1210, 1211, Ch. 8W10



Sparton MODEL 1210 MAHOGANY
MODEL 1211 BLONDE
AM-FM RADIO-PHONOGRAPH COMBINATION



Sparton TABLE RADIO
MODEL 241 MAHOGANY
MODEL 242 BLONDE
8 TUBE, AM - FM

BRIEF DESCRIPTION

MODEL 1210 in Mahogany and 1211 in Blond are Radio-Phonograph combinations incorporating the 8W10 radio chassis and an automatic record changer.

RADIO CHASSIS 8W10: is an eight-tube A.M.-F.M. Super-Heterodyne receiver. This compact receiver contains a built-in line cord antenna for local F.M. reception and full range tone control.

AUTOMATIC RECORD CHANGER: The record changer in these models is a VM-950 Tri-o-matic three-speed changer.

MODELS 241, 242,
1210, 1211, Ch. 8W10

CHASSIS DIAGRAM

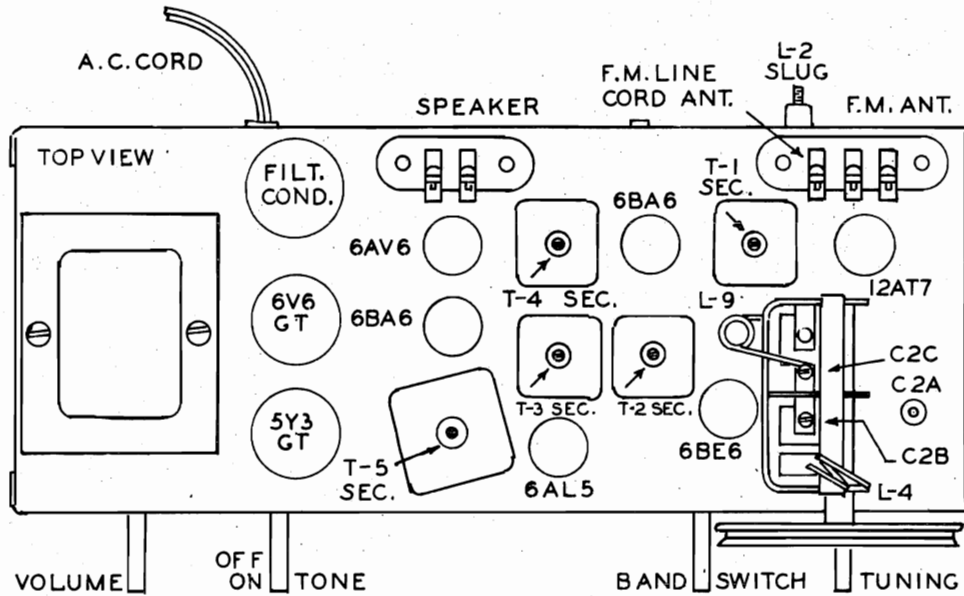
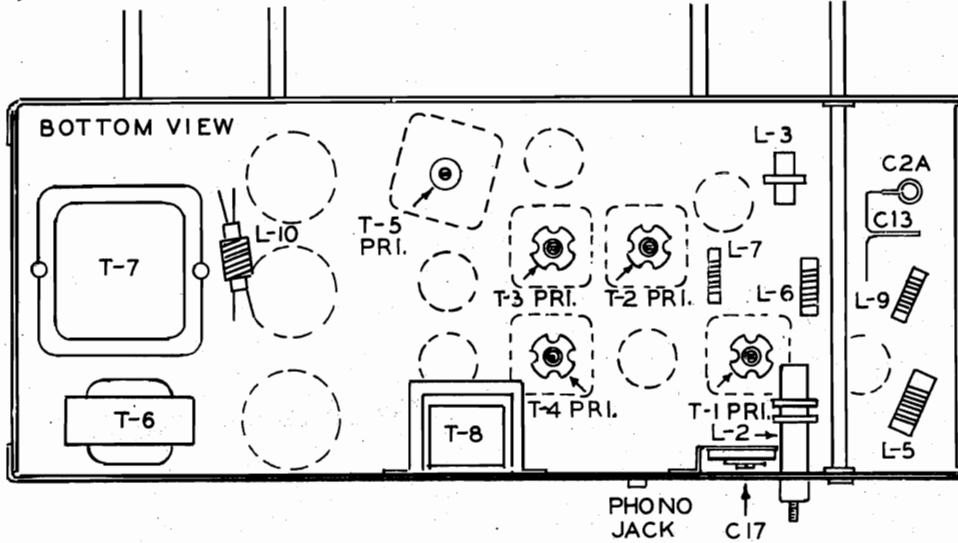

TOP VIEW

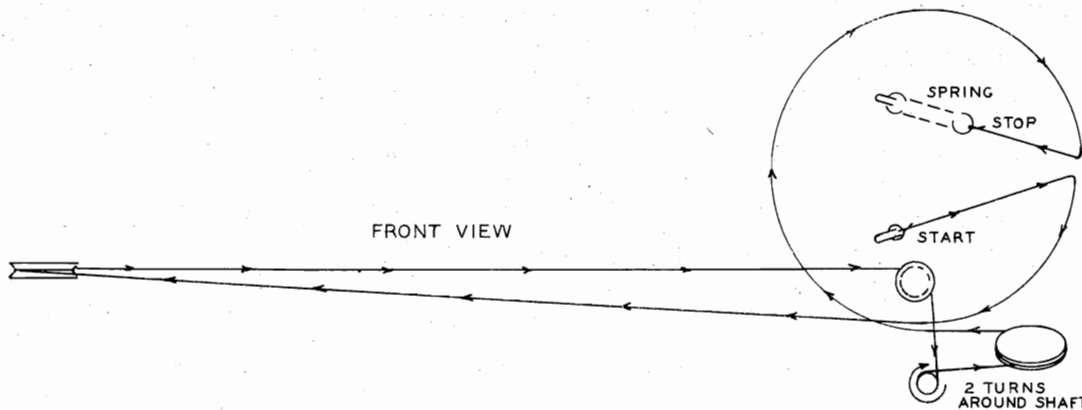
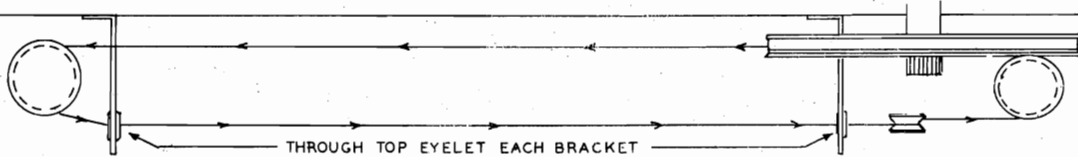

MODELS 241, 242,
1210, 1211, Ch. 8W10

ALIGNMENT DATA

OPERATION	ALIGNMENT OF	GENERATOR CONNECTED TO	DUMMY ANT.	GENERATOR FREQUENCY	BAND SWITCH SETTING	TUNING COND SETTING	TRIMMER OR SLUG	REMARKS
1.	Set Dial pointer even with left-hand stop line with condenser gang closed.							
2.	Connect output meter across speaker terminals.							
3.	A.M.-I.F.	Pin #7 of 6BE6 Conv. Tube	.02 MFD Cond.	456 KC.	A.M.	Open	T4 Sec. Slug	Max. Reading
							T4 Pri. Slug	Max. Reading
							T2 Sec. Slug	Max. Reading
							T2 Pri. Slug	Max. Reading
4.	Repeat Operation #3.							
5.		A.M. Ant.		1500 KC.		1500 KC	C2B Osc.Tri.	Peak Accurately
6.	A.M.-R.F.	On Cabinet	*	1500 KC.	A.M.	1500 KC	C17 Ant. Tri.	Peak Accurately
7.	A.M.-R.F.	On Cabinet	*	600 KC.	A.M.	600 KC	L-2 Slug	Max. Reading
8.	Repeat operations #5, #6 and #7.							
9.	Check Calibrations at 600, 1000 and 1500 KC.							
10.	<u>SPECIAL NOTE:</u> For complete F.M.-I.F. Visual Alignment instructions please refer to Pages 5-8.							
11.	F.M.-I.F. Alignment using an A.M. Generator and Output Meter.							
12.	T5 F.M. Ratio Det.	Pin #1 of 2nd 6BA6 Tube	.02 MFD. Cond.	10.7 MC.	F.M.	Open	T5 Sec. Slug	Max. Reading
							T5 Pri. Slug	Max. Reading
13.	NOTE: Operations 11, 12, 14, 15, 18 and 19 must be made with generator output as low as possible, consistent with usable output meter reading.							
14.	T3 2nd. F.M.-I.F.	Pin #1 1st 6BA6 Tube	.02 MFD. Cond.	10.7 MC.	F.M.	Open	T3 Sec. Slug	Max. Reading
							T3 Pri. Slug	Max. Reading
15.	T1 1st F.M.-I.F.	Pin #8 on 12AT7 Mixer Tube	.02 MFD. Cond.	10.7 MC.	F.M.	Open	T1 Sec. Slug	Max. Reading
							T1 Pri. Slug	Max. Reading
16.	Adjust secondary slug on T5 ratio detector transformer to minimum deflection or dip on output meter. Under certain conditions it is possible to adjust T5 sec. slug to minimum noise with the receiver tuned to a weak station. This operation is very critical and the receiver must be tuned to the center response only.							
17.	F.M.-R.F. alignment using an A.M. Generator with frequencies of 88 to 108 MC. and a vacuum tube voltmeter or D.C. voltmeter. (20,000 Ohms per volt).							
18.	Place meter across C36 elect. condenser. (Meter reading approximately 1 volt)							
19.	F.M.-R.F.	F.M. Ant.	Match Gen. TO 300 Ohm	106 MC.	F.M.	106 MC.	C2A Osc. Tri.	Max. Reading
							C2C Ant. Tri.	Peak Accurately
20.	Check Calibration at 88 MC.							

* Use standard dummy antenna as described on Page 4.

MODELS 241, 242,
1210, 1211, Ch. 8W10

VOLTAGE CHART

TUBE	FUNCTION	Voltage of Sockets Prongs to Ground See Prong Nos. on Schematic.								
		No.1	No. 2	No. 3	No. 4	No. 5	No. 6	No. 7	No. 8	No. 9
6BE6	A.M. Conv. & F.M. Osc.	-2.5	0	0	6.3*	90	80	**		
12AT7X	F.M. -R.F. & Mixer	135	-0.6	0	0	0	150	-1	1.2	6.3*
6BA6	I. F. Amp.	-0.1	0	6.3*0		235	100	1.0		
6BA6X	Ratio Det. Driver	-0.5	0	6.3*0		95	90	1.2		
6AL5	Ratio Det.	0	-0.25	5.6*0		0	0	0		
6AV6	1st A.F.-A.M. Det. & A.V.C.	-0.1	0	6.3*0		-0.1	-0.1	95		
6V6GT	Power Amplifier	0	0	0	250	260	0	240	6.3*	14
5Y3GT	Rectifier	0	0	270	260*			260*		270

Line Voltage: 117 Volts AC
Position of volume control: Full with set tuned to quiet channel. Position of band switch A.M.

NOTES: Voltage readings are for schematic diagram in this bulletin. Allow 15% / or - on all measurements. Always use meter scale which will give greater deflection within scale limits. All D. C. measurements made with 20,000 ohms per volt voltmeter. All AC voltages made with rectifier type voltmeter.

* AC Volts

** Cannot be measured with 20,000 ohms per volt voltmeter.

X Band switch on F.M.

DUMMY ANTENNA

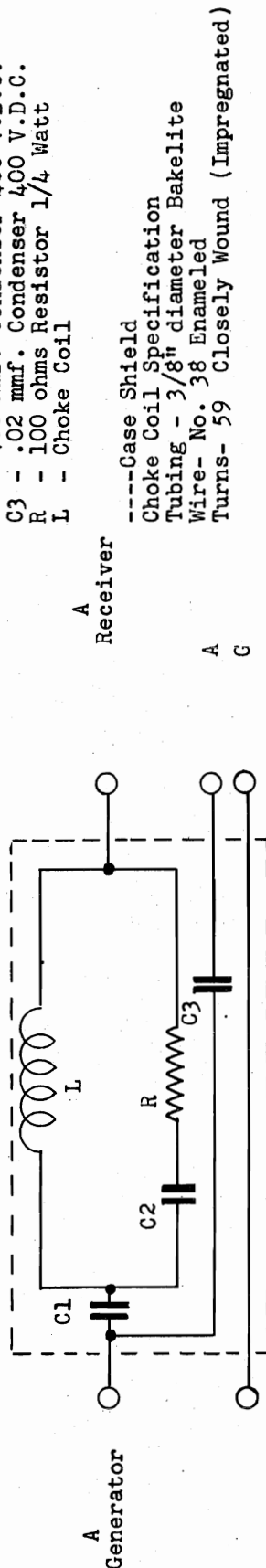

- C1 - 200 mmf. Condenser 400 V.D. C.
- C2 - 400 mmf. Condenser 400 V.D.C.
- C3 - .02 mmf. Condenser 400 V.D.C.
- R - 100 ohms Resistor 1/4 Watt
- L - Choke Coil

- Case Shield
- Choke Coil Specification
- Tubing - 3/8" diameter Bakelite
- Wire- No. 38 Enameled
- Turns- 59 Closely Wound (Impregnated)

NOTE: When using this dummy antenna the generator output impedance should be 10 ohms or lower.

MODELS 241, 242,
1210, 1211,
Ch. 8W10

VISUAL I. F.-F. M. ALIGNMENT DATA

WARNING: Do not proceed with any of the following alignment instructions unless it is certain that the AM-IF is in accurate alignment. If not, align the AM-IF system according to the step by step alignment procedure.

1. DESCRIPTION OF CIRCUIT USED:

A 6AL5 is employed as a ratio detector. This tube is preceded by a 6BA6 ratio detector driver and a stage of amplification at 10.7 Mc. also utilizing a 6BA6 tube. The 2nd section of the 12AT7 tube is used as the FM mixer. All IF coupling uses individual slug tuned transformers.

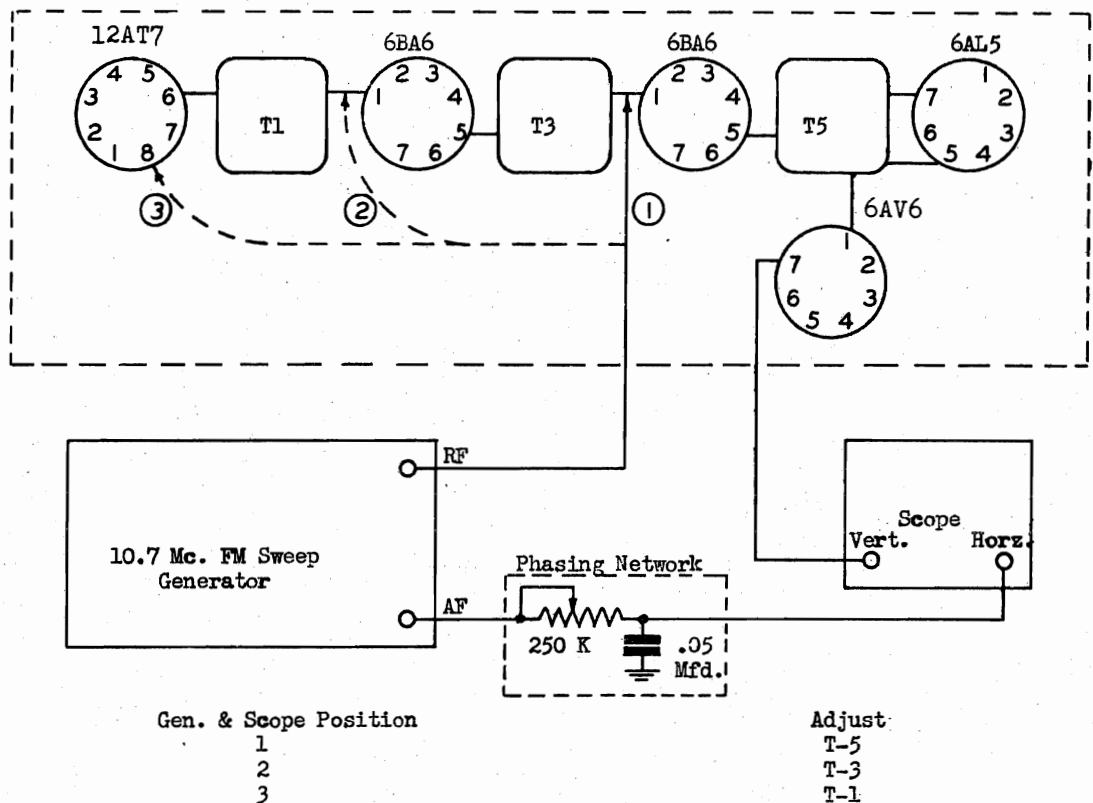

2. THEORY OF VISUAL ALIGNMENT.

One of the characteristics of a tuned circuit is the fact that when it is excited or driven by a generator such as a vacuum tube or another tuned circuit, the voltage developed across it will vary with slight changes in frequency. This voltage will be greatest when the frequency is equal to the resonant frequency of the circuit and will be less if the frequency is higher or lower than the resonant frequency.

Thus if we were to shift the frequency from high to low or low to high across the resonant frequency and make a record of the voltage across the tuned circuit, we could plot the voltage against frequency and obtain a curve which might look like Fig. 1.

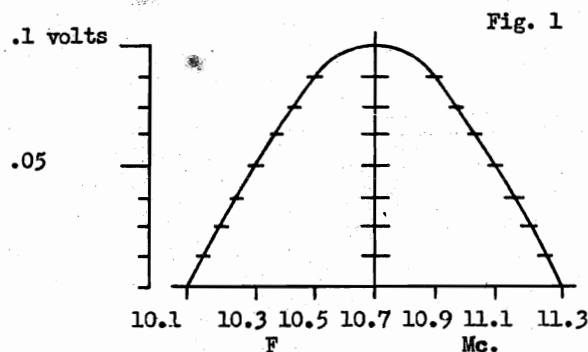

MODELS 241, 242,
1210, 1211, Ch. 8W10

This is the selectivity curve or response curve for the circuit under discussion. This type of circuit may be aligned or adjusted to resonance by simply changing either L or C until maximum voltage is obtained at the resonant frequency. Now if another circuit tuned to the same resonant frequency is coupled to the simple case above, a number of things can happen. First current flowing in one circuit will induce current in the second circuit, the magnitude of this current depending on the degree or amount of coupling between the two circuits. This coupling may be in the form of mutual inductance, mutual capacitance or any impedance common to the two circuits. Now if we repeat the procedure outlined for obtaining the response curve of a single tuned circuit using the voltage developed across the secondary of the coupled circuit while driving the primary, we may get either of two types of curves depending on the magnitude of the coupling, (a) in Fig. 2 is a typical curve for two circuits coupled below critical coupling and (b) is a representation of the curve for an over coupled circuit.

Fig. 2

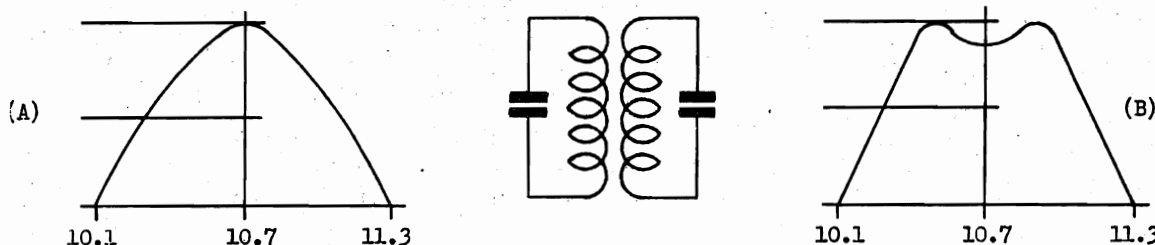

Overcoupled circuits producing a response curve like (b) Fig. 2 are often employed where it is important that the response curve remain approximately flat over a narrow band of frequencies near the resonant frequency. They are also frequently combined with single peaked circuits to produce a response curve like Fig. 3.

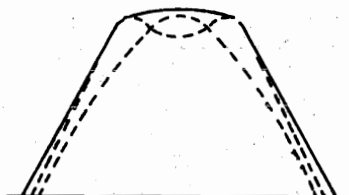

Fig. 3

The dotted lines indicate the curves of the individual circuits and the solid curve shows the overall response of the two or more pairs of coupled circuits. Circuits like the above or approaching them in form are desirable in an FM receiver where the pass band should be of the order of 200 Kc. Now from the above it is evident that simple peaking both sides of a circuit coupled below critical for maximum voltage will provide optimum alignment but if this procedure is followed with an over-coupled circuit it is almost a certainty that the two circuits will not be tuned to the resonant frequency but will instead be aligned so that either one or the other is accentuated. The response curve will then look like Fig. 4 (a) or (b).

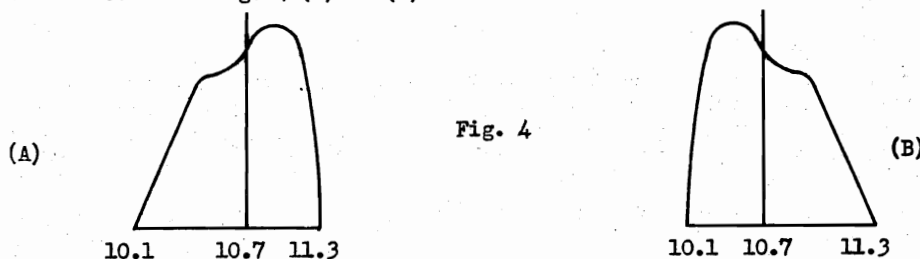
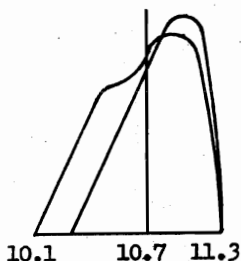

Fig. 4

Now if this overcoupled circuit is combined with a single peaked circuit (where the coupling is below critical), the misalignment becomes worse, something like Fig. 5.

Fig. 5



MODELS 241, 242,
1210, 1211, Ch. 8W10

VISUAL I. F. - F. M. ALIGNMENT DATA

From the above it appears that to properly align a receiver using overcoupled IF transformers it will be necessary to take a response curve of each stage and align the circuit so that the two peaks are symmetrical, that is, approximately equal in amplitude and displaced equally from the center frequency. To do this with a CW or AM signal would be laborious and time consuming whereas the use of visual equipment makes it nearly as simple as adjusting a simple single peaked amplifier.

Visual alignment test equipment performs the operation of plotting the response curve almost exactly as described above except that instead of manually changing the generator frequency, recording the voltage and then plotting the results, these operations are performed automatically and simultaneously by a combination of electronic circuits. The operation is briefly as follows.

In the signal generator a low AC voltage is applied to a reactance tube modulator which shifts the oscillator frequency from low to high or from high to low at a rate determined by the frequency of the AC voltage and by an amount determined by the AC voltage. The frequency at any instant is dependant on the AC voltage present at that instant of time. An oscilloscope is provided which may be considered a voltmeter used to read the voltage across the tuned circuit, provided a detector is used to convert the RF to a low audio frequency. This voltage is then applied to the vertical plates and results in a vertical displacement of the spot on the screen. Some of the voltage used to shift the oscillator frequency is also applied to the horizontal plates of the oscilloscope providing a means of displacing the spot horizontally. It is now evident that since for any given AC voltage only one frequency may be obtained and since that AC voltage will result in an exact amount of spot deflection on the scope we can read the voltage across the circuit under examination by noticing the position of the spot at this exact instant.

Now if we consider the frequency as shifting from low to high 60 times per second and remember that the spot is moving across the screen of the scope 60 times per second at exact synchronization with the change in frequency it is only necessary to apply the voltage from our circuit to the vertical plates to obtain a replica of the response curve on the face of the cathode ray tube. This curve will be repeated 60 times per second if our sweep frequency is 60 cycles. Adjustments to the circuit may now be made and the effect on the response curve noted instantaneously.

Although it is possible to observe the selectivity curves as shown in Fig. 1, 2, and 3 on the scope by the use of an auxiliary special detector coupled to the plate of the last IF tube, it is much more convenient to observe the effects of IF alignment upon the shape of the ratio detector output trace. When this is done the auxiliary detector is not necessary and a direct connection of the scope into the receiver circuits will provide all the necessary connections.

If the overall selectivity curve is not "flat-topped" (solid line in Fig. 3) the ratio detector curve cannot be linear (straight) throughout the center section, symmetrical and have sufficient band width (Fig. 6).

Under these conditions it would not be possible to receive a signal without distortion and higher than normal noise, the degree of distortion and abnormal noise dependent upon the extent to which the center of the ratio detector trace departs from a straight line and the extent to which the entire trace departs from true symmetry.

After a pattern similar to Fig. 6 is obtained with connection #1 shown in the block diagram, the generator lead may be moved ahead through the IF system one tube at a time and the intervening transformer aligned for maximum output but at all times a curve very similar to Fig. 6 must be maintained.

3. EQUIPMENT REQUIRED.

(a) A sweep signal generator with a center frequency of 10.7 Mc. and a total sweep width of at least 400 Kc. Examination of the block diagram will reveal a variable resistor-capacitor circuit inserted in the lead between the FM sweep generator and the horizontal amplifier of the oscilloscope. This control should be adjusted so that the dual trace observed on the oscilloscope will blend into a single trace and thereby eliminate any confusion due to the two traces.

(b) An Oscilloscope with either a 3" or 5" tube equipped with both vertical and horizontal amplifiers.

4. ALIGNMENT OF THE 10.7 I.F.

Turn the wave band switch to F.M. and the generator to 10.7 Mc. Connect the F.M. signal generator output lead to the grid of the ratio detector driver tube and the scope to the 1st audio plate. Now proceed to align the ratio detector transformer for maximum linearity and output, being careful to maintain as symmetrical a trace as possible. Note that the adjustment of the secondary circuit, controls to a large extent, the linearity and symmetry of the pattern, and adjustment of the primary will influence the gain of the circuit. Fig. 6 represents a linear detector curve properly aligned.

MODELS 241, 242,
1210, 1211, Ch. 8W10

It is important that the generator sweep a sufficiently wide band of frequencies so that the curves on both ends of the straight portion can be seen. Maximum linearity of alignment will result when these curves are symmetrically shaped and as previously stated this will result in minimum distortion and noise.

Fig. 6

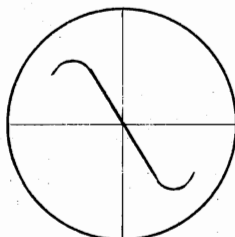

Connect the generator output lead to the grid of the I.F. amplifier. Align primary and secondary of the I.F. transformer being careful to maintain the same basic ratio detector trace as just described.

Observe that by alternately adjusting the primary and secondary, the vertical amplitude can be increased without the response curve becoming distorted. At all times it is important to reduce the signal generator output to maintain the scope picture on the screen. This will avoid overload and possible misalignment therefrom.

Move the generator lead to the grid of the converter tube and align No. 1 I.F. transformer following the same procedure as above.

Fig. 7, (A), (B), (C), and (D) represent typical selectivity curves of an overall I.F. Amplifier. Fig. 7, (AA), (BB), (CC), and (DD) represent the corresponding ratio detector curves.

Fig. 7

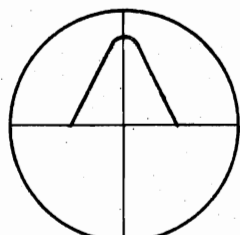

(A)
Not Overcoupled
Properly Aligned
(Right)

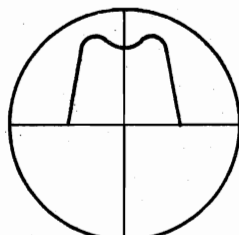

(B)
Overcoupled
Properly Aligned
(Right)

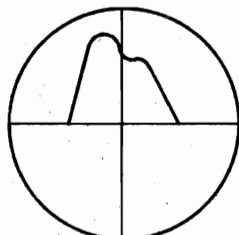

(C)
Overcoupled
Improperly Aligned
(Wrong)

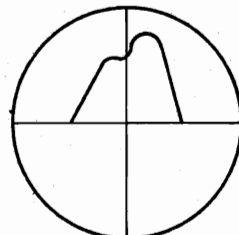

(D)
Overcoupled
Improperly Aligned
(Wrong)

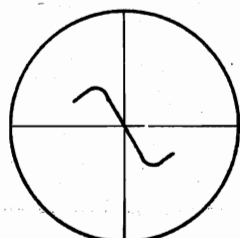

(AA)
Narrow Bandpass

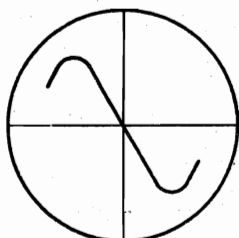

(BB)
Proper Alignment

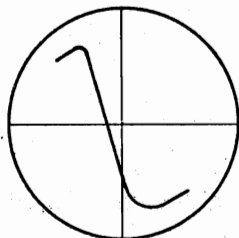

(CC)
Overcoupled

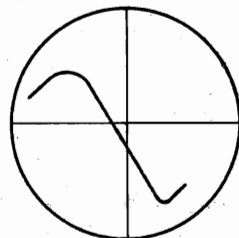

(DD)
IF Transformer
Improperly Aligned

Should the trace appear unsatisfactory, a very slight readjustment of the detector secondary alignment may be made at this time as the need for any but a slight correction is an indication of incorrect alignment in one of the other stages. This is permissible only if the degree of correction necessary is slight. If this is not the case the entire alignment procedure should be repeated.

MODELS 241, 242,
1210, 1211, Ch. 8W10

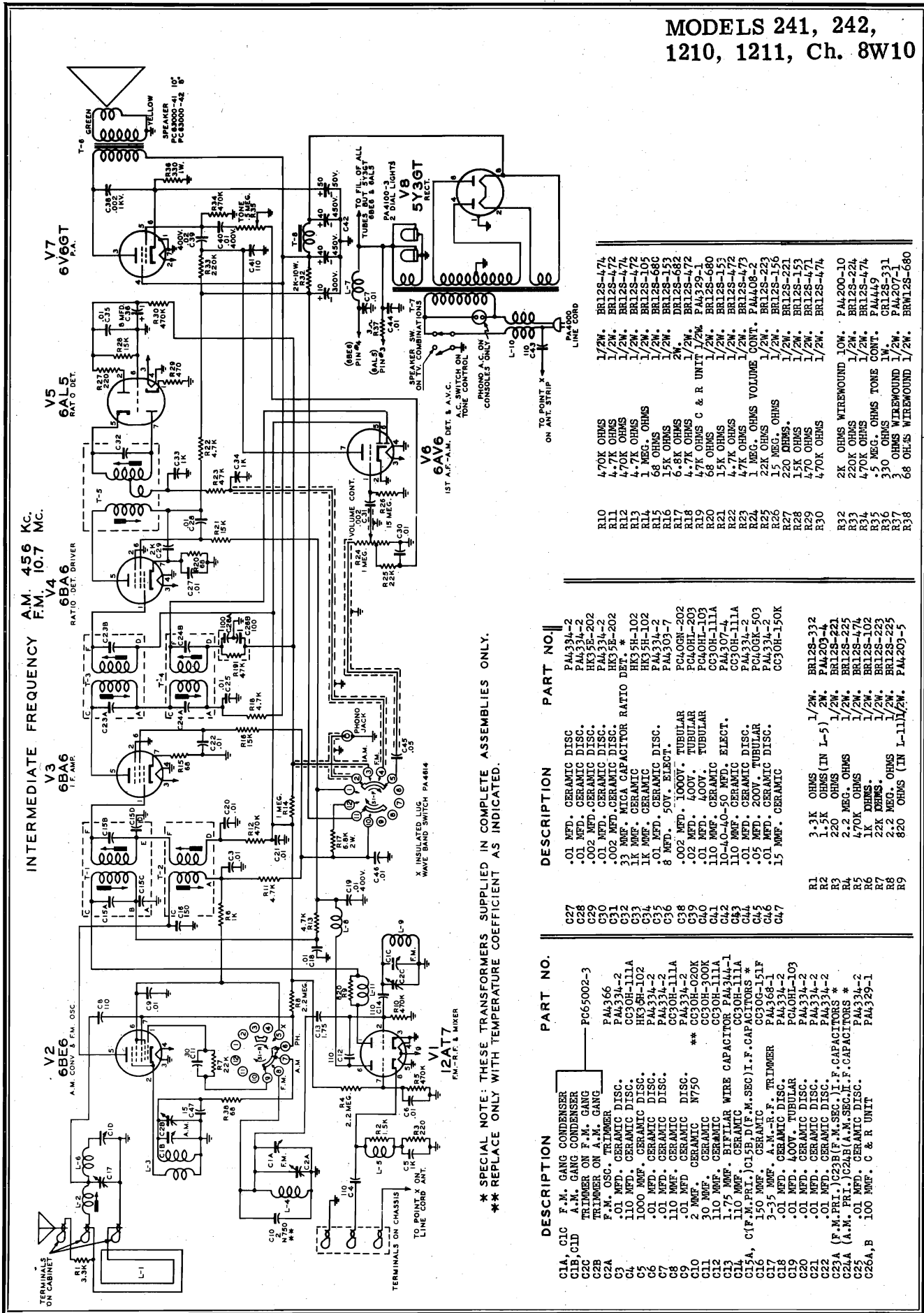

© John F. Rider

DESCRIPTION	PART NO.
C1A, C1C F.M. GANG CONDENSER	PG65002-3
C1B, C1D A.M. GANG CONDENSER	
C2B TRIMMER ON F.M. GANG	
C2A F.M. OSC. TRIMMER	PA4366
C3 F.M. OSC. TRIMMER	PA4334-2
C4 .01 MFD. CERAMIC DISC.	CC30H-111A
C5 100 MFD. CERAMIC DISC.	HK35H-102
C6 .01 MFD. CERAMIC DISC.	PA4334-2
C7 .01 MFD. CERAMIC DISC.	PA4334-2
C8 .01 MFD. CERAMIC DISC.	PA4334-2
C9 .01 MFD. CERAMIC DISC.	PA4334-2
C10 2 MFD. CERAMIC DISC.	PA4334-2
C11 30 MFD. CERAMIC DISC.	CC30H-020K
C12 1.0 MFD. CERAMIC DISC.	CC30H-111A
C13 1.75 MFD. BIFILAR WIRE CAPACITOR	PA4344-1
C14 1.0 MFD. CERAMIC DISC.	CC30H-111A
C15A, C15B, C15C I.F. CAPACITORS *	CC30H-111A
C16 150 MFD. A.M.-R.F. TRIMMER	CC30G-151F
C17 3-35 MFD. A.M.-R.F. TRIMMER	PA4368-1
C18 .01 MFD. CERAMIC DISC.	PA4334-2
C19 .01 MFD. CERAMIC DISC.	PA4334-2
C20 .01 MFD. CERAMIC DISC.	PA4334-2
C21 .01 MFD. CERAMIC DISC.	PA4334-2
C22 .01 MFD. CERAMIC DISC.	PA4334-2
C23A (F.M. PRI.) C23B (F.M. SEC.) I.F. CAPACITORS *	CC30H-111A
C24A (A.M. PRI.) C24B (A.M. SEC.) I.F. CAPACITORS *	CC30H-111A
C25 .01 MFD. CERAMIC DISC.	PA4334-2
C26A, B 100 MFD. C & R UNIT	PA4329-1
R1 3.3K OHMS (IN L-5)	2W.
R2 1.5K OHMS	2W.
R3 2.2 MEG. OHMS	1/2W.
R4 470K OHMS	1/2W.
R5 1K OHMS	1/2W.
R6 22K OHMS	1/2W.
R7 2.2 MEG. OHMS (IN L-1111/2W.)	1/2W.
R8 820 OHMS	1/2W.
R9 820 OHMS	1/2W.
R10 470K OHMS	1/2W.
R11 4.7K OHMS	1/2W.
R12 4.7K OHMS	1/2W.
R13 4.7K OHMS	1/2W.
R14 4.7K OHMS	1/2W.
R15 68 OHMS	1/2W.
R16 1.5K OHMS	1/2W.
R17 6.8K OHMS	1/2W.
R18 4.7K OHMS	1/2W.
R19 4.7K OHMS C & R UNIT	PA4329-1
R20 68 OHMS	1/2W.
R21 1.5K OHMS	1/2W.
R22 4.7K OHMS	1/2W.
R23 4.7K OHMS	1/2W.
R24 1 MEG. OHMS VOLUME CONT.	PA4408-2
R25 22K OHMS OHMS	1/2W.
R26 15 MEG. OHMS	1/2W.
R27 220 OHMS	1/2W.
R28 15K OHMS	1/2W.
R29 470K OHMS	1/2W.
R30 470K OHMS	1/2W.
R31 2K OHMS WIREWOUND	PA4200-10
R32 220K OHMS	1/2W.
R33 470K OHMS	1/2W.
R34 5 MEG. OHMS TONE CONT.	PA4200-10
R35 3.0 OHMS	1/2W.
R36 3.0 OHMS WIREWOUND	PA4200-10
R37 68 OHMS WIREWOUND	1/2W.
R38 68 OHMS WIREWOUND	1/2W.
L1 1/2W.	BR12S-474
L2 1/2W.	BR12S-472
L3 1/2W.	BR12S-474
L4 1/2W.	BR12S-472
L5 1/2W.	BR12S-105
L6 1/2W.	BR12S-686
L7 1/2W.	BR12S-153
L8 1/2W.	BR12S-682
L9 1/2W.	BR12S-472
L10 1/2W.	PA4329-1
L11 1/2W.	BR12S-680
L12 1/2W.	BR12S-153
L13 1/2W.	BR12S-472
L14 1/2W.	BR12S-474
L15 1/2W.	BR12S-472
L16 1/2W.	BR12S-156
L17 1/2W.	BR12S-221
L18 1/2W.	BR12S-153
L19 1/2W.	BR12S-474
L20 1/2W.	BR12S-474

MODELS 241, 242, 1210, 1211,
Ch. 8W10; 380, 381, 1304, 1305, Ch. 8L3

DESCRIPTION	PART NO.		
L-1 LOOP ANTENNA	PA5250-3,4 or 7		
L-2 LOOP LOADING COIL	AA6616-1		
L-3 B.C.OSC. COIL	AA6665-3		
L-4 F.M.OSC. COIL	PA5200-8		
L-5 100 MC.CHOKE COIL (1500A FORM	AA6798-3	KNOB-VOLUME	PA5654-1
L-6 CHOKE COIL	AA6769-2	KNOB-TONE-ON/OFF	PA5654-2
L-7 CHOKE COIL	AA6798-6	KNOB-BAND SWITCH	PA5654-3
L-8 CHOKE COIL	AA6769-2	KNOB-TUNING	PA5654-4
L-9 F.M. R.F. COIL	PA5200-9	DIAL SCALE	PB30017
L-10 LINE CORD ANT. CHOKE	AA6664-1	ESCUTCHEON-MODEL 1210	PD93027-1
L-11 CHOKE COIL	AA6798-7	ESCUTCHEON-MODEL 1211	PD93027-2
T-1 NO. 1 I.F. F.M. TRANS.	AA6667-1	RECORD PLAYER-VM950	PD93110
T-2 NO. 1 I.F. A.M. TRANS.	AA6668-5		
T-3 NO. 2 I.F. F.M. TRANS.	AA6667-3		
T-4 NO. 2 I.F. A.M. TRANS.	AA6668-1		
T-5 RATIO DETECTOR	AA6684-1		
T-6 OUTPUT TRANS.	AB44061-2		
T-7 POWER TRANS.	AB44013-1		
T-8 FILTER CHOKE	AB47004-1		

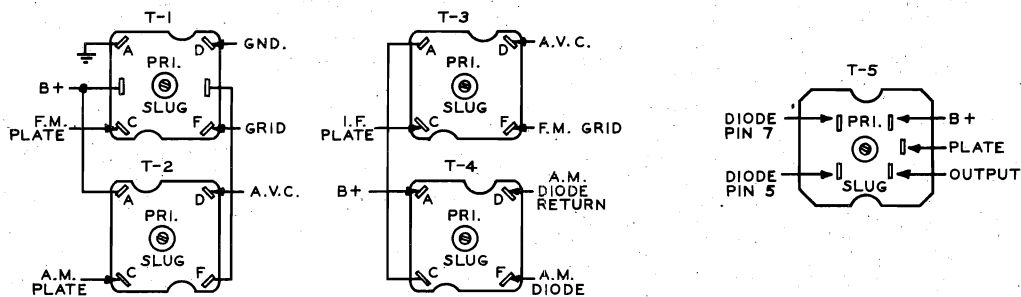

BOTTOM VIEW, TERMINAL HOOKUP FOR T-1, T-2, T-3, T-4 & T-5

ELECTRICAL CHARACTERISTICS OF CHASSIS TYPE 8L3 ARE IDENTICAL TO THAT OF CHASSIS TYPE 8W10

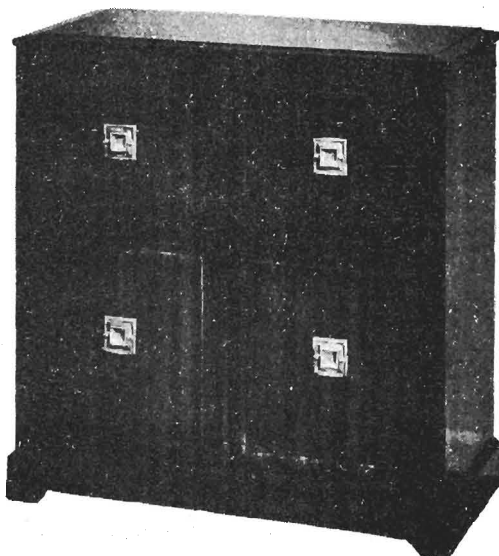

Sparton MODEL 1304
MAHOGANY RADIO-PHONO COMB.
8 TUBE AM-FM RADIO;
3-SPEED RECORD PLAYER

Sparton MODEL 1305
GOLDEN WHEAT RADIO-PHONO COMB.
8 TUBE AM-FM RADIO;
3-SPEED RECORD PLAYER

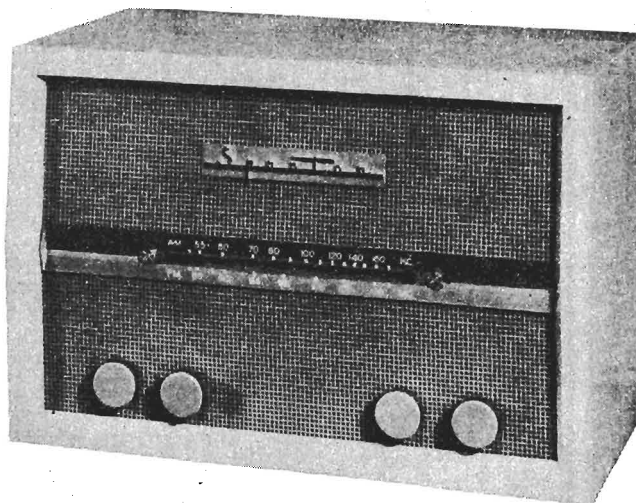

Sparton MODEL 380
GENUINE MAHOGANY
8 TUBE AM-FM WITH PHONO JACK
AND 8L3 CHASSIS

Sparton MODEL 381
GOLDEN WHEAT
8 TUBE AM-FM WITH PHONO JACK
AND 8L3 CHASSIS

MODELS 380, 381, 1304, 1305, Ch. 8L3

INTERMEDIATE FREQUENCY A.M. 456 KC. F.M. 10.7 MC.

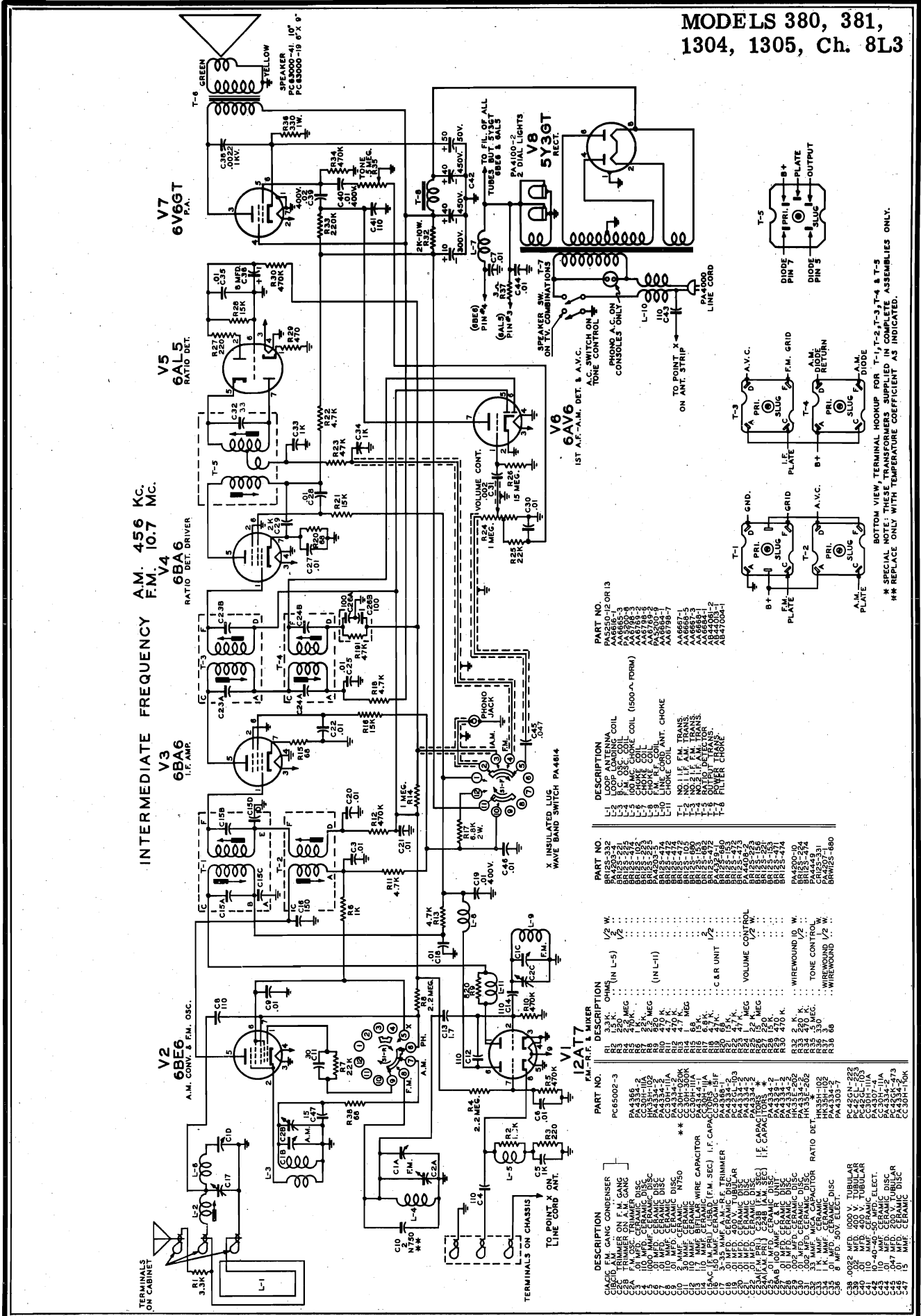

DESCRIPTION	PART NO.	DESCRIPTION	PART NO.
CLASSIC F.M. GANG CONDENSER	PC65002-3	LOOP ANTENNA COIL	PA2520-12 OR 13
TRIMMER ON T.M. GANG	PA3365-1	F.M. OSC. COIL	AA8616-1
5000 MFD. CERAMIC DISC	PC3334-1	F.M. OSC. COIL (1500- Δ FORM)	AA8616-2
5000 MFD. CERAMIC DISC	PC3334-2	CHOKE COIL	AA8616-3
5000 MFD. CERAMIC DISC	PC3334-3	CHOKE COIL	AA8616-4
5000 MFD. CERAMIC DISC	PC3334-4	CHOKE COIL	AA8616-5
5000 MFD. CERAMIC DISC	PC3334-5	CHOKE COIL	AA8616-6
5000 MFD. CERAMIC DISC	PC3334-6	CHOKE COIL	AA8616-7
5000 MFD. CERAMIC DISC	PC3334-7	CHOKE COIL	AA8616-8
5000 MFD. CERAMIC DISC	PC3334-8	CHOKE COIL	AA8616-9
5000 MFD. CERAMIC DISC	PC3334-9	CHOKE COIL	AA8616-10
5000 MFD. CERAMIC DISC	PC3334-10	CHOKE COIL	AA8616-11
5000 MFD. CERAMIC DISC	PC3334-11	CHOKE COIL	AA8616-12
5000 MFD. CERAMIC DISC	PC3334-12	CHOKE COIL	AA8616-13
5000 MFD. CERAMIC DISC	PC3334-13	CHOKE COIL	AA8616-14
5000 MFD. CERAMIC DISC	PC3334-14	CHOKE COIL	AA8616-15
5000 MFD. CERAMIC DISC	PC3334-15	CHOKE COIL	AA8616-16
5000 MFD. CERAMIC DISC	PC3334-16	CHOKE COIL	AA8616-17
5000 MFD. CERAMIC DISC	PC3334-17	CHOKE COIL	AA8616-18
5000 MFD. CERAMIC DISC	PC3334-18	CHOKE COIL	AA8616-19
5000 MFD. CERAMIC DISC	PC3334-19	CHOKE COIL	AA8616-20
5000 MFD. CERAMIC DISC	PC3334-20	CHOKE COIL	AA8616-21
5000 MFD. CERAMIC DISC	PC3334-21	CHOKE COIL	AA8616-22
5000 MFD. CERAMIC DISC	PC3334-22	CHOKE COIL	AA8616-23
5000 MFD. CERAMIC DISC	PC3334-23	CHOKE COIL	AA8616-24
5000 MFD. CERAMIC DISC	PC3334-24	CHOKE COIL	AA8616-25
5000 MFD. CERAMIC DISC	PC3334-25	CHOKE COIL	AA8616-26
5000 MFD. CERAMIC DISC	PC3334-26	CHOKE COIL	AA8616-27
5000 MFD. CERAMIC DISC	PC3334-27	CHOKE COIL	AA8616-28
5000 MFD. CERAMIC DISC	PC3334-28	CHOKE COIL	AA8616-29
5000 MFD. CERAMIC DISC	PC3334-29	CHOKE COIL	AA8616-30
5000 MFD. CERAMIC DISC	PC3334-30	CHOKE COIL	AA8616-31
5000 MFD. CERAMIC DISC	PC3334-31	CHOKE COIL	AA8616-32
5000 MFD. CERAMIC DISC	PC3334-32	CHOKE COIL	AA8616-33
5000 MFD. CERAMIC DISC	PC3334-33	CHOKE COIL	AA8616-34
5000 MFD. CERAMIC DISC	PC3334-34	CHOKE COIL	AA8616-35
5000 MFD. CERAMIC DISC	PC3334-35	CHOKE COIL	AA8616-36
5000 MFD. CERAMIC DISC	PC3334-36	CHOKE COIL	AA8616-37
5000 MFD. CERAMIC DISC	PC3334-37	CHOKE COIL	AA8616-38
5000 MFD. CERAMIC DISC	PC3334-38	CHOKE COIL	AA8616-39
5000 MFD. CERAMIC DISC	PC3334-39	CHOKE COIL	AA8616-40
5000 MFD. CERAMIC DISC	PC3334-40	CHOKE COIL	AA8616-41
5000 MFD. CERAMIC DISC	PC3334-41	CHOKE COIL	AA8616-42
5000 MFD. CERAMIC DISC	PC3334-42	CHOKE COIL	AA8616-43
5000 MFD. CERAMIC DISC	PC3334-43	CHOKE COIL	AA8616-44
5000 MFD. CERAMIC DISC	PC3334-44	CHOKE COIL	AA8616-45
5000 MFD. CERAMIC DISC	PC3334-45	CHOKE COIL	AA8616-46
5000 MFD. CERAMIC DISC	PC3334-46	CHOKE COIL	AA8616-47
5000 MFD. CERAMIC DISC	PC3334-47	CHOKE COIL	AA8616-48
5000 MFD. CERAMIC DISC	PC3334-48	CHOKE COIL	AA8616-49
5000 MFD. CERAMIC DISC	PC3334-49	CHOKE COIL	AA8616-50
5000 MFD. CERAMIC DISC	PC3334-50	CHOKE COIL	AA8616-51
5000 MFD. CERAMIC DISC	PC3334-51	CHOKE COIL	AA8616-52
5000 MFD. CERAMIC DISC	PC3334-52	CHOKE COIL	AA8616-53
5000 MFD. CERAMIC DISC	PC3334-53	CHOKE COIL	AA8616-54
5000 MFD. CERAMIC DISC	PC3334-54	CHOKE COIL	AA8616-55
5000 MFD. CERAMIC DISC	PC3334-55	CHOKE COIL	AA8616-56
5000 MFD. CERAMIC DISC	PC3334-56	CHOKE COIL	AA8616-57
5000 MFD. CERAMIC DISC	PC3334-57	CHOKE COIL	AA8616-58
5000 MFD. CERAMIC DISC	PC3334-58	CHOKE COIL	AA8616-59
5000 MFD. CERAMIC DISC	PC3334-59	CHOKE COIL	AA8616-60
5000 MFD. CERAMIC DISC	PC3334-60	CHOKE COIL	AA8616-61
5000 MFD. CERAMIC DISC	PC3334-61	CHOKE COIL	AA8616-62
5000 MFD. CERAMIC DISC	PC3334-62	CHOKE COIL	AA8616-63
5000 MFD. CERAMIC DISC	PC3334-63	CHOKE COIL	AA8616-64
5000 MFD. CERAMIC DISC	PC3334-64	CHOKE COIL	AA8616-65
5000 MFD. CERAMIC DISC	PC3334-65	CHOKE COIL	AA8616-66
5000 MFD. CERAMIC DISC	PC3334-66	CHOKE COIL	AA8616-67
5000 MFD. CERAMIC DISC	PC3334-67	CHOKE COIL	AA8616-68
5000 MFD. CERAMIC DISC	PC3334-68	CHOKE COIL	AA8616-69
5000 MFD. CERAMIC DISC	PC3334-69	CHOKE COIL	AA8616-70
5000 MFD. CERAMIC DISC	PC3334-70	CHOKE COIL	AA8616-71
5000 MFD. CERAMIC DISC	PC3334-71	CHOKE COIL	AA8616-72
5000 MFD. CERAMIC DISC	PC3334-72	CHOKE COIL	AA8616-73
5000 MFD. CERAMIC DISC	PC3334-73	CHOKE COIL	AA8616-74
5000 MFD. CERAMIC DISC	PC3334-74	CHOKE COIL	AA8616-75
5000 MFD. CERAMIC DISC	PC3334-75	CHOKE COIL	AA8616-76
5000 MFD. CERAMIC DISC	PC3334-76	CHOKE COIL	AA8616-77
5000 MFD. CERAMIC DISC	PC3334-77	CHOKE COIL	AA8616-78
5000 MFD. CERAMIC DISC	PC3334-78	CHOKE COIL	AA8616-79
5000 MFD. CERAMIC DISC	PC3334-79	CHOKE COIL	AA8616-80
5000 MFD. CERAMIC DISC	PC3334-80	CHOKE COIL	AA8616-81
5000 MFD. CERAMIC DISC	PC3334-81	CHOKE COIL	AA8616-82
5000 MFD. CERAMIC DISC	PC3334-82	CHOKE COIL	AA8616-83
5000 MFD. CERAMIC DISC	PC3334-83	CHOKE COIL	AA8616-84
5000 MFD. CERAMIC DISC	PC3334-84	CHOKE COIL	AA8616-85
5000 MFD. CERAMIC DISC	PC3334-85	CHOKE COIL	AA8616-86
5000 MFD. CERAMIC DISC	PC3334-86	CHOKE COIL	AA8616-87
5000 MFD. CERAMIC DISC	PC3334-87	CHOKE COIL	AA8616-88
5000 MFD. CERAMIC DISC	PC3334-88	CHOKE COIL	AA8616-89
5000 MFD. CERAMIC DISC	PC3334-89	CHOKE COIL	AA8616-90
5000 MFD. CERAMIC DISC	PC3334-90	CHOKE COIL	AA8616-91
5000 MFD. CERAMIC DISC	PC3334-91	CHOKE COIL	AA8616-92
5000 MFD. CERAMIC DISC	PC3334-92	CHOKE COIL	AA8616-93
5000 MFD. CERAMIC DISC	PC3334-93	CHOKE COIL	AA8616-94
5000 MFD. CERAMIC DISC	PC3334-94	CHOKE COIL	AA8616-95
5000 MFD. CERAMIC DISC	PC3334-95	CHOKE COIL	AA8616-96
5000 MFD. CERAMIC DISC	PC3334-96	CHOKE COIL	AA8616-97
5000 MFD. CERAMIC DISC	PC3334-97	CHOKE COIL	AA8616-98
5000 MFD. CERAMIC DISC	PC3334-98	CHOKE COIL	AA8616-99
5000 MFD. CERAMIC DISC	PC3334-99	CHOKE COIL	AA8616-100

MODELS 320C, 321C,
325C, 329C, Ch. 5B3C

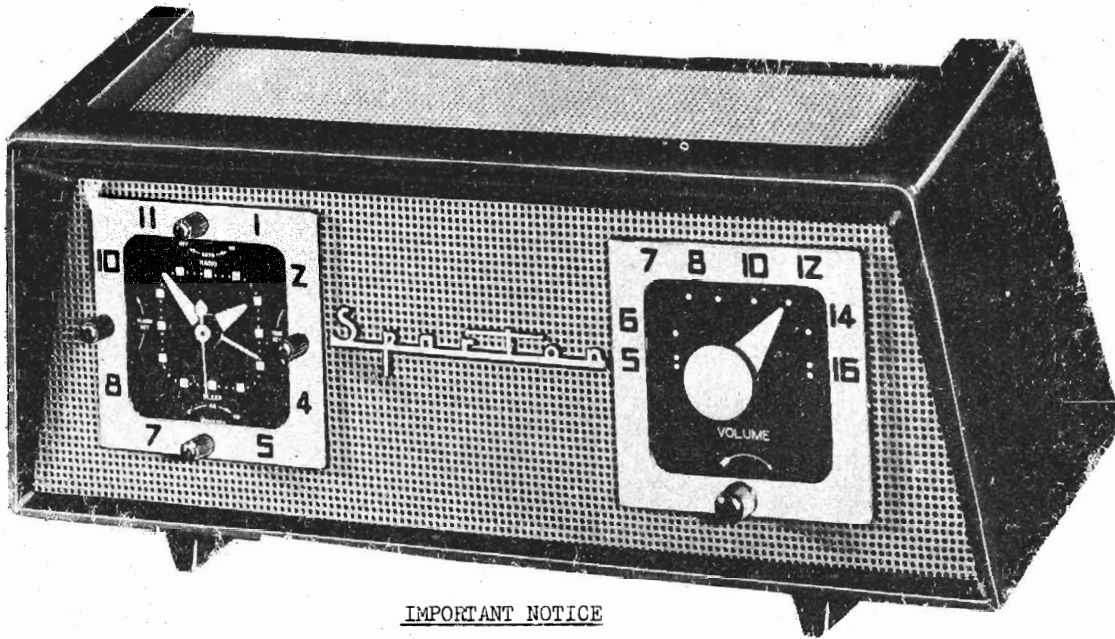

IMPORTANT NOTICE

- A. All defective clocks used on Sparton radios must be returned to our Factory for replacement.
- B. Clock parts will not be stocked or shipped to the field for clock repair by dealer servicemen.
- C. To remove the defective clock for shipment to our Factory, the following procedure must be used.
 - 1. Remove clock by removing the two (2) screws on the back of housing. Do not return clock housing.
 - 2. Do not cut, but unsolder the three clock lead wires at their points of connection on the chassis base.
 - 3. Defective clocks must be properly tagged with defective material tag and properly packed to prevent transportation damage.
- D. Violation of this procedure will automatically void the warranty on the defective clock.

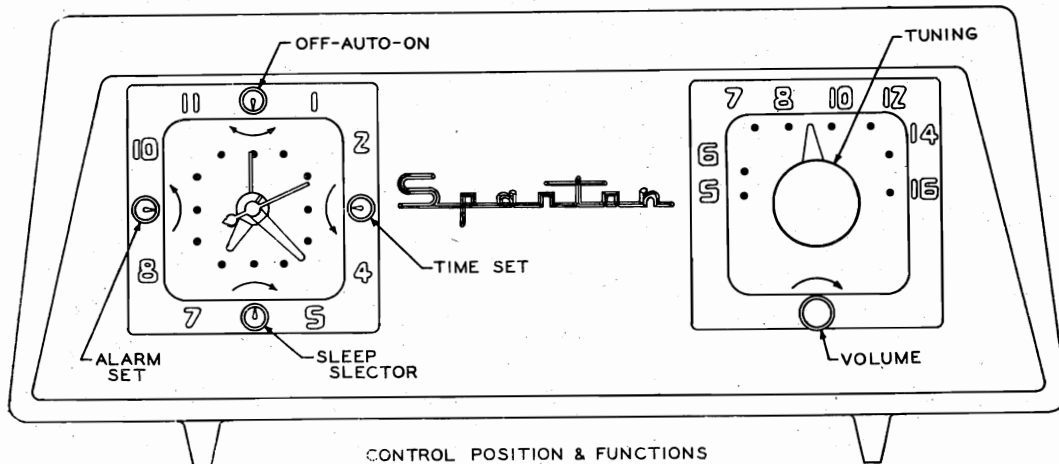

CONTROL POSITION & FUNCTIONS

MODELS 320C, 321C,
325C, 329C, Ch. 5B3C

CHASSIS TYPE 5B3C

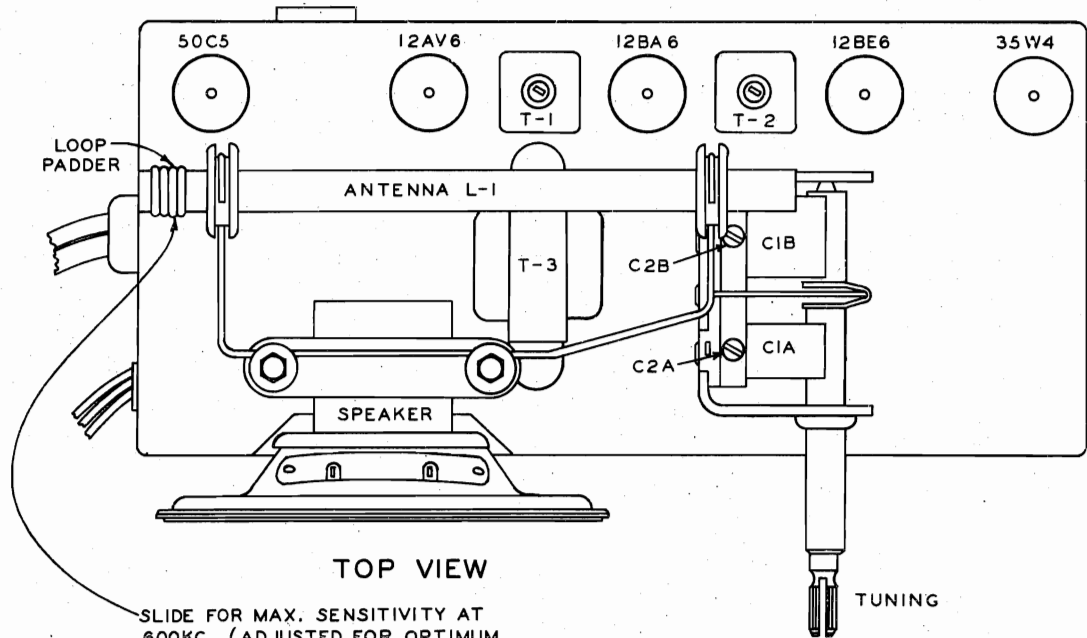

TOP VIEW

SLIDE FOR MAX. SENSITIVITY AT 600KC. (ADJUSTED FOR OPTIMUM LOOP PERFORMANCE AT THE FACTORY. FIELD ADJUSTMENT USUALLY UNNECESSARY.)

BOTTOM VIEW

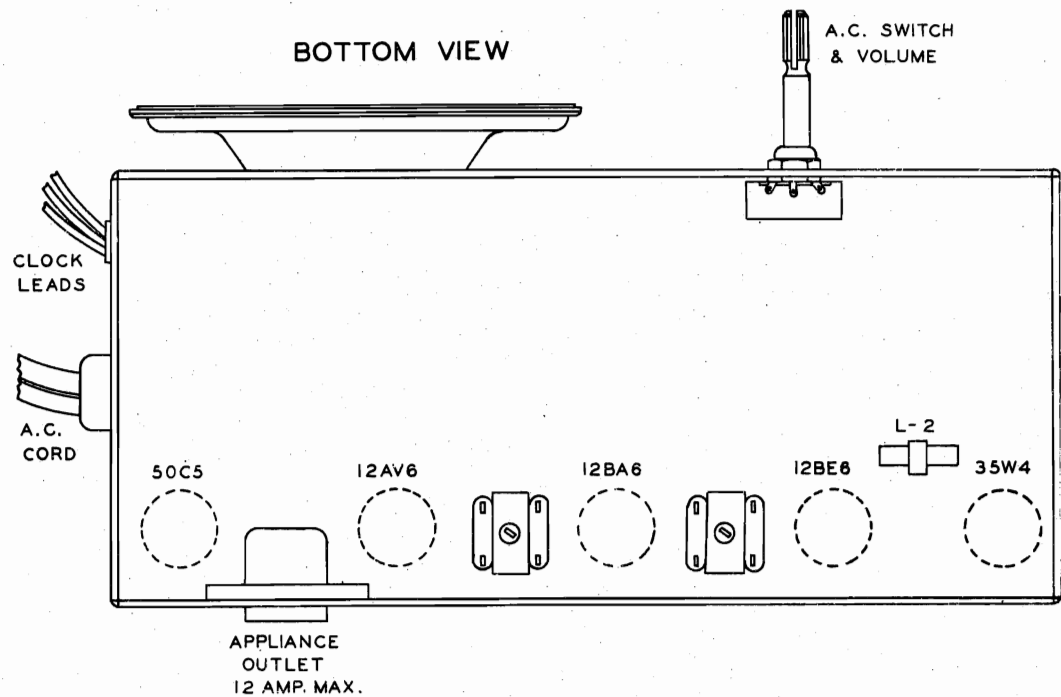

MODELS 320C, 321C,
325C, 329C, Ch. 5B3C

VOLTAGE CHART

Line Voltage: 117 Volts AC		Position of volume control: Full with set tuned to quiet channel.							
TUBE	FUNCTION	Voltage of Sockets Prongs to B- See Prong Nos. on Schematic.							
		No. 1	No. 2	No. 3	No. 4	No. 5	No. 6	No. 7	No. 8
12BE6	Converter	**	0	23*	11.5*	95	95	**	
12BA6	I.F. Amp.	**	0	23*	34.5*	95	93	0.55	
12AV6	2nd Det. & Audio Amp.	**	0	11.5*	0	***	0	48	
50C5	Power Amp.	6.3	0	84.5*	34.5*	0	95	115	0
35W4	Rectifier	0	118	84.5*	117*	117*	108*	120	

NOTES: Voltage readings are for schematic diagram in this bulletin. Allow 15% \pm or - on all measurements. Always use meter scale which will give greatest deflection within scale limits. All DC measurements made with 20,000 ohms per volt voltmeter. All AC voltages made with rectifier type voltmeter.

- * AC Volts.
- ** Cannot be measured with 20,000 ohms per volt voltmeter.

STEP BY STEP ALIGNMENT PROCEDURE

OPERATION	ALIGNMENT OF	GENERATOR CONNECTED TO	DUMMY ANTENNA	GENERATOR FREQUENCY	TUNING COND. SETTING	TRIMMER	REMARKS
1.	I.F.	Pin #7 on 12BE6	.02 MFD. Cond.	456 KC.	Fully Open	Slug T-2 Top & Bottom	Peak Accurately
						Slug T-1 Top & Bottom	Peak Accurately
2.	Broadcast	*	Driver Loop	1500 KC.	1500 KC.	C2A Osc. Tr.	Peak Accurately
						C2D Osc. Tr.	**
						C2B Ant. Tr.	***
3.	Repeat operations 1 and 2						
4.	Check calibrations at 600, 1000 and 1500 KC.						

- * Use driver loop as shown below.
- ** Trimmer C2D as shown on schematic is preset at factory and only on certain conditions will have to be re-adjusted in the field. This trimmer is located on bottom side of gang.
- *** Rock dial while adjusting for maximum output.

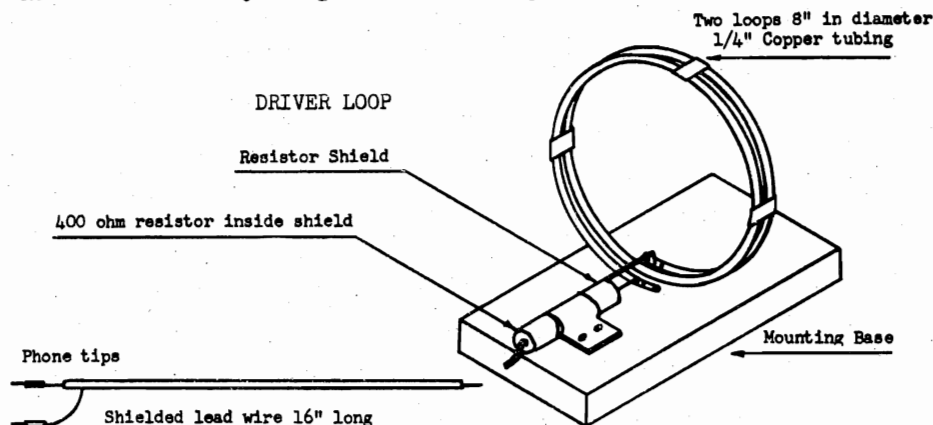

SPECIFICATIONS

Two loops of 1/4" copper tubing 8" in diameter spaced 1/4" apart with 400 ohms resistor in series. Connecting cable and resistor must be shielded. The loop should be spaced twice the diameter of the loop from the receiver being aligned to prevent an over modulated signal and poor alignment of the receiver.

MODELS 320C, 321C,
325C, 329C, Ch. 5B3C;
360, 361, 365, 369,
Ch. 5B3

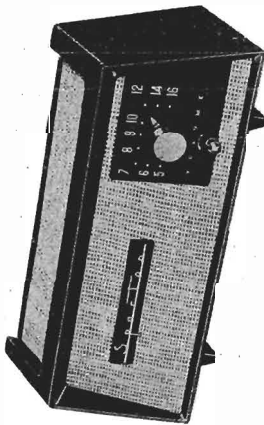

360 - CHARCOAL
361 - BROWN
365 - GREEN
369 - SAND

INTERMEDIATE FREQUENCY 456KC.

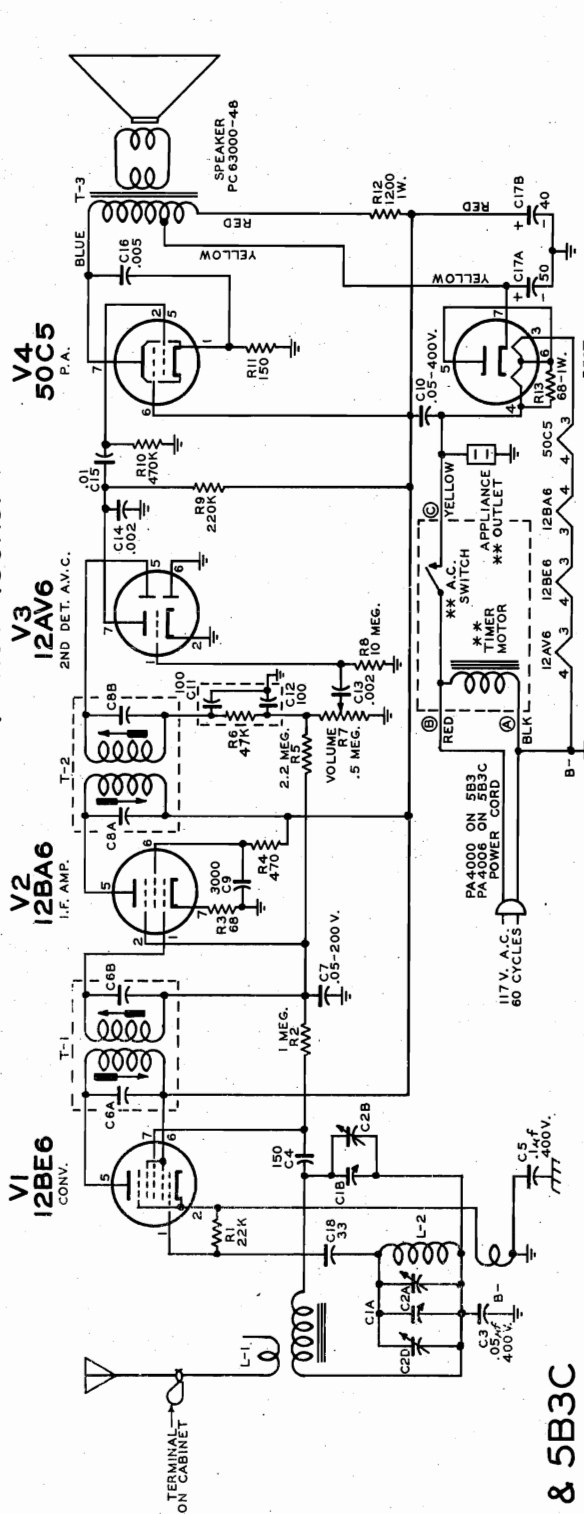

5B3 & 5B3C

DESCRIPTION	PART NO.	DESCRIPTION	PART NO.
C1A,B GANG CONDENSER	SEE NOTE BELOW	R1 22K OHMS	BR125-223
C2A,B TRIMMERS ON GANG		R2 1MEG.	BR12N-105
C3 150 MFD. CERAMIC TUBULAR	PC401L-503	R3 470	BR12S-690
C4 150 MFD. CERAMIC TUBULAR	PC431L-503	R4 470	BR12N-225
C5 .1 MFD. 400V. TUBULAR	PC40FL-104	R5 2.2 MEG.	SEE NOTE
C6A,B .01 MFD. CAPACITORS	PC40K-503	R6 47K. C & R UNIT	PA4320-1
C7A,B .01 MFD. CAPACITORS	PC40K-503	R7 10 MEG. OHMS	BR12N-106
C8A,B .01 MFD. CAPACITORS	PC40K-503	R8 10 MEG. OHMS	BR12N-224
C9 3000 MFD. CERAMIC	HK35F-302	R9 220K	BR12N-474
C10 100 MFD. CERAMIC	PC40HL-503	R10 150K	CR125-124
C11 100 MFD. CERAMIC	PC40HL-503	R11 150K	CR125-124
C12 2K MFD. CERAMIC	PA4329-1	R12 1200 OHMS	CR125-680
C13 2K MFD. CERAMIC	PA4329-1	L1 LOOP ANT. ASSEMBLY	AB43592-1
C14 .005 MFD. CERAMIC	PA4334-3	L2 OSC. COIL ASSEMBLY	AA6797-5
C15 .01 MFD. CERAMIC	PA4334-3	T1 NO. 1 I.F. TRANSFORMER ASSEMBLY	FB42201-3
C16 .005 MFD. CERAMIC	PA4334-1	T2 " " " "	AB44039-1
C17A,B 40-50 MFD. ELECTROLYTIC	PA4347-2	T3 " " " "	AB44039-1
C18 .33 MFD. CERAMIC			

DESCRIPTION	PART NO.	DESCRIPTION	PART NO.
L1 LOOP ANT. ASSEMBLY	AB43592-1	L2 OSC. COIL ASSEMBLY	AA6797-5
L2 OSC. COIL ASSEMBLY	AA6797-5	T1 NO. 1 I.F. TRANSFORMER ASSEMBLY	FB42201-3
T1 NO. 1 I.F. TRANSFORMER ASSEMBLY	FB42201-3	T2 " " " "	AB44039-1
T2 " " " "	AB44039-1	T3 " " " "	AB44039-1
T3 " " " "	AB44039-1	NOTE: VOLUME CONTROL (MODEL 5B3)	FA4400-12
NOTE: VOLUME CONTROL (MODEL 5B3)	FA4400-12	VOLUME CONTROL (MODEL 5B3C)	FA4455-1
VOLUME CONTROL (MODEL 5B3C)	FA4455-1		

INDICATES CONNECTION TO B- BUSS, NOT CHASSIS.
INDICATES CHASSIS CONNECTION.
SPECIAL SERVICE NOTE: THESE TRANSFORMERS SUPPLIED IN COMPLETE ASSEMBLIES ONLY.
TIMER UNIT IN 5B3 ON VOLUME CONTROL.
A.C. SWITCH IN 5B3C ON VOLUME CONTROL.

RESISTOR COLOR CODES:
(Charcoal) PA567-1
(Green) PA567-2
(Brown) PA567-3
(Sand) PA567-4
(Sand) PA567-5

CAPACITOR COLOR CODES:
(Charcoal) PA567-1
(Green) PA567-2
(Brown) PA567-3
(Sand) PA567-4
(Sand) PA567-5

*SPEAKER: 5-Inch P053000-4B
*Complete speaker may be returned to the factory Service Department for repair or replacement.

MODELS 301, 305,
309, Ch. 4E3

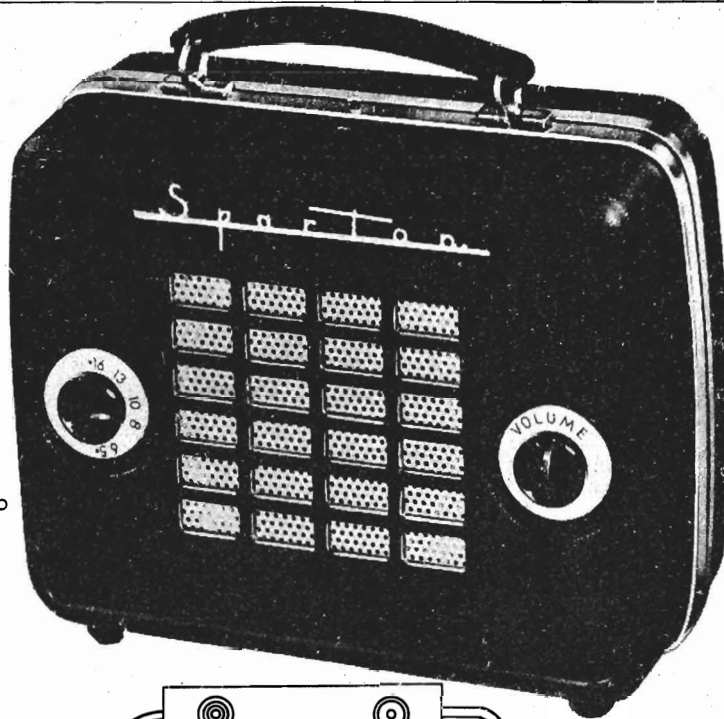

Sparton AC-DC PORTABLE RADIO
 MODEL 301 - BROWN
 MODEL 305 - GREEN
 MODEL 309 - IVORY

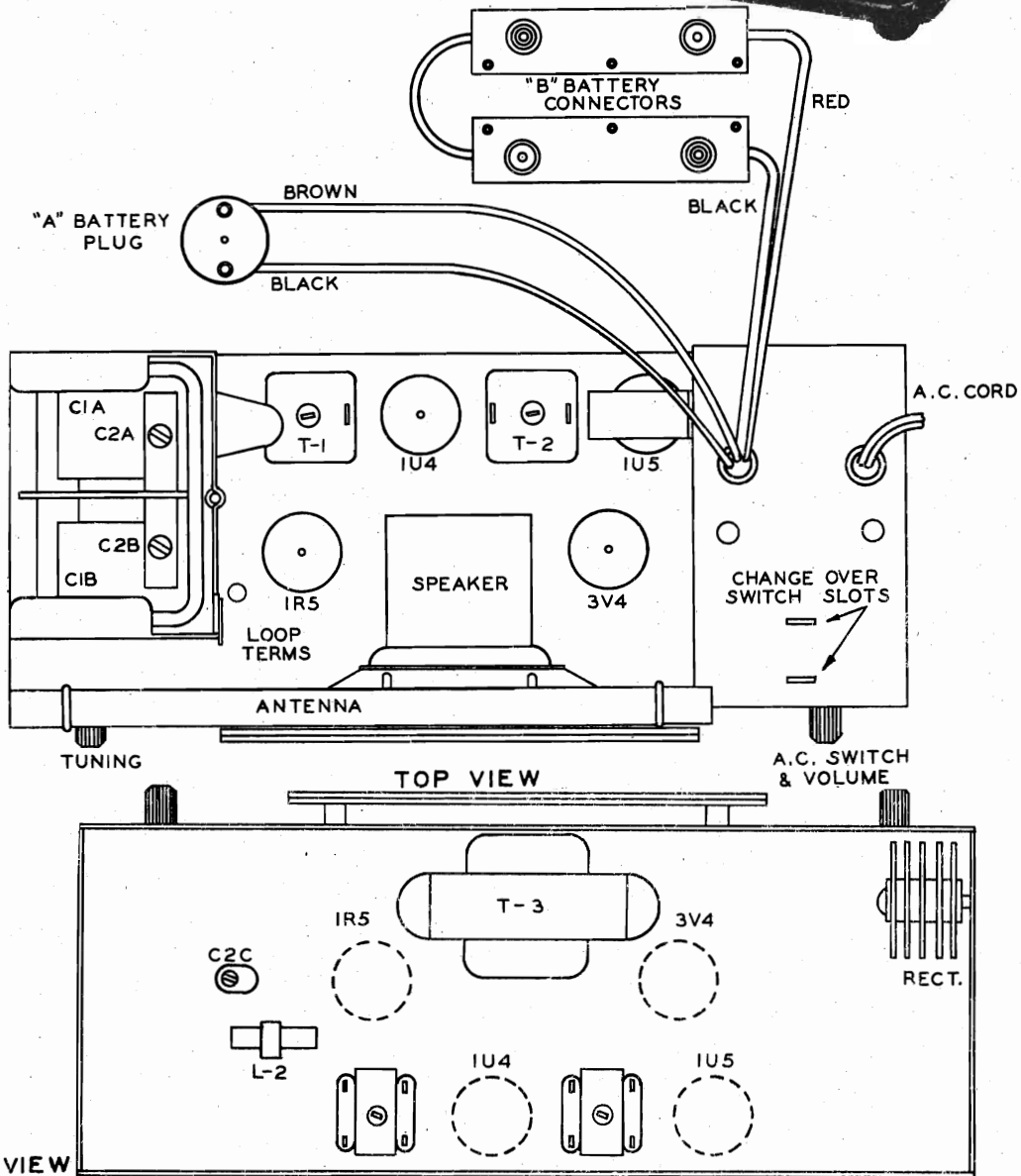

CHASSIS TYPE 4E3

VOLTAGE CHART

Line Voltage: 117 Volts AC		Position of volume control: Full with set tuned to quiet channel.						
TUBE	FUNCTION	Voltage of Sockets Prongs to -B See Prong Nos. on schematic.						
		No. 1	No. 2	No. 3	No. 4	No. 5	No. 6	No. 7
1R5	Osc. Converter	1.37	93	60	**	1.37	0	2.7
1U4	I.F. Amplifier	2.7	93	93	0	2.7	0	4.1
1U5	Det. A.V.C. & 1st Audio	1.37	15	11.5	0	0	0	0
3V4	Output	4.1	93	93	0	5.9	0	7.5

NOTES: Voltage readings are for schematic diagram in this bulletin. Allow 15% / or - on all measurements. Always use meter scale which will give greatest deflection within scale limits. All DC measurements made with 20,000 ohms per volt voltmeter. All AC voltages made with rectifier type voltmeter.

** Cannot be measured with 20,000 Ohms per volt voltmeter.

STEP BY STEP ALIGNMENT PROCEDURE

OPERATION	ALIGNMENT OF	GENERATOR CONNECTED TO	DUMMY ANTENNA	GENERATOR FREQUENCY	TUNING COND. SETTING	TRIMMER	REMARKS
1.	I.F.	Pin #6 1R5 Tube	.1 Mfd. Cond.	456 KC.	Open	Slug T-2 Top & Bottom	Peak accurately
						Slug T-1 Top & Bottom	Peak accurately
2.	Osc.	Separate Loop	*	1620 KC.	Open	C2B Osc.Tr.	Peak accurately
3.	R.F.		*	1500 KC.	1500 KC.	C2A Ant.Tr.	Peak accurately
4.	Repeat Operation #3.						
5.	Check calibration at 600 KC., 1000 KC. and 1500 KC.						
6.	Check Operations #1 to #6 inclusive.						

* Use driver loop as shown in this bulletin. The generator must be connected to the dummy loop antenna and not to the loop of the receiver for R.F. alignments. Trimmer C2C as shown on schematic is preset at factory and only on certain conditions will have to be moved. However, should it become necessary to adjust this trimmer on the bottom of the gang a cutout in the chassis base has been provided.

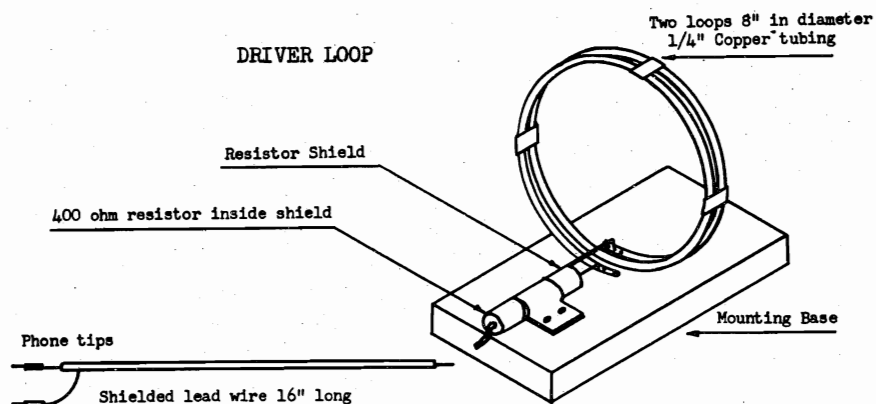

SPECIFICATIONS

Two loops of 1/4" copper tubing 8" in diameter spaced 1/4" apart with 400 ohms resistor in series. Connecting cable and resistor must be shielded. The loop should be spaced twice the diameter of the loop from the receiver being aligned to prevent an over modulated signal and poor alignment of the receiver.

MODELS 301, 305,
309, Ch. 4E3

**SCHEMATIC DIAGRAM
SPARTON SUPERHETERODYNE MODEL 4E3
INTERMEDIATE FREQUENCY 456KC**

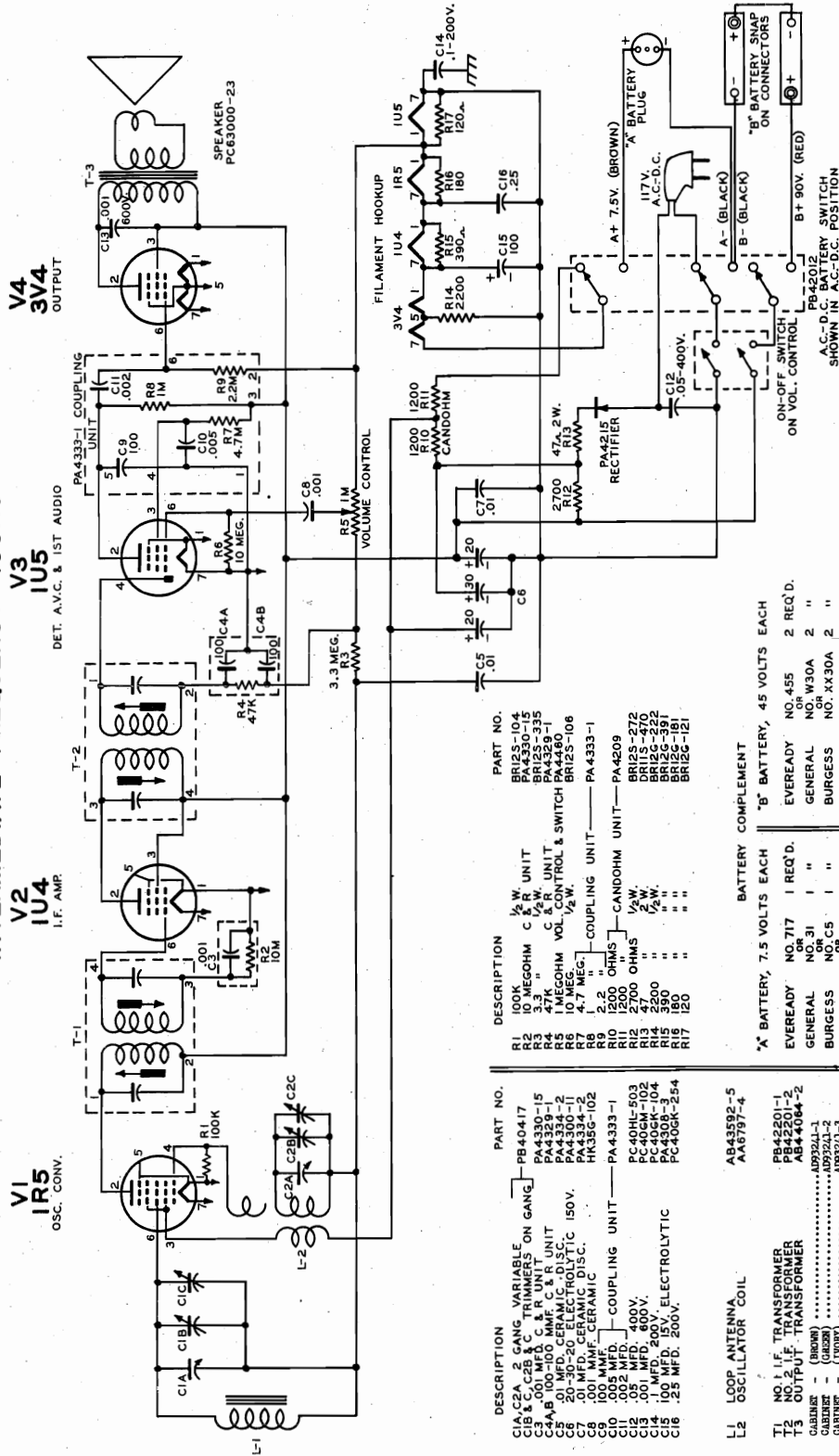

DESCRIPTION	PART NO.	DESCRIPTION	PART NO.
R1 100K OHMS	BR125-104	R10 1200 OHMS	PA4333-1
R2 3.3K "	BR125-335	R11 1200 OHMS	PA4209
R3 3.3K "	BR125-335	R12 2700 OHMS	BR125-272
R4 47K "	PA4329-1	R13 2700 OHMS	BR125-222
R5 10MEG OHM VOL. CONTROL & SWITCH	BR125-106	R14 2200 "	BR125-391
R6 4.7K "		R15 390 "	BR125-121
R7 4.7MEG "		R16 180 "	
R8 1.2K "		R17 120 "	
R9 4.7M "			
R10 1200 OHMS			

DESCRIPTION	PART NO.	DESCRIPTION	PART NO.
C1A .001 MFD. 50V	PA4014-1	C11 .001 MFD. 50V	PA4014-1
C1B .001 MFD. 50V	PA4014-1	C12 .01 MFD. 50V	PA4014-1
C1C .001 MFD. 50V	PA4014-1	C13 .01 MFD. 50V	PA4014-1
C1D .001 MFD. 50V	PA4014-1	C14 .01 MFD. 50V	PA4014-1
C1E .001 MFD. 50V	PA4014-1	C15 .01 MFD. 50V	PA4014-1
C1F .001 MFD. 50V	PA4014-1	C16 .01 MFD. 50V	PA4014-1

BATTERY	COMPLEMENT
"A" BATTERY, 7.5 VOLTS EACH	"B" BATTERY, 45 VOLTS EACH
EVEREADY NO. 717	EVEREADY NO. 455
OR NO. 31	OR NO. 30A
GENERAL NO. C5	GENERAL NO. XX30A
BURGESS NO. A47	BURGESS NO. XX30A
ENGLISH NO. A47	ENGLISH NO. XX30A

*COMPLETE SPEAKERS MAY BE RETURNED TO FACTORY SERVICE DEPARTMENT FOR REPAIR OR REPLACEMENT.

SPECIFICATIONS

Power Supply.....	105-125 volts 60 cycle AC only.
Power Consumption.....	65 Watts.
Frequency Range FM.....	88 to 108 MC.
Frequency Range AM.....	540 to 1600 KC.
I.F. Frequency FM.....	10.7 MC.
I.F. Frequency AM.....	455 KC.
Band width, FM, Ratio Detector.....	330 KC.
Band width, FM, 1st I.F.....	280 KC.
Band width, FM, Converter.....	220 KC.

The tubes used are as follows:

12AT7	FM RF Amplifier, Converter
6BE6	FM Osc, Am Osc, Converter
6BA6	FM-AM, 1st I.F. Amplifier
6BA6	FM, 2nd I.F. Amplifier
6AL5	FM Detector
6AT6	AM Detector, AVC, Audio
6AQ5	Power Output
6X4	Power Rectifier
No. 44	Pilot Lights (2)

SERVICE NOTES

GENERAL

CAUTION: If realignment is necessary be sure the proper test equipment is available, as listed below, before proceeding with the alignment procedure

Due to the high frequencies at which FM signals are received the service man must use great care when servicing these sets. Extreme caution must be used regarding the moving of component parts in the R.F. and oscillator circuits of the receiver as those circuits can be detuned in this manner.

If it becomes necessary to replace components such as resistors and condensers they must be replaced with parts of the same size, type, voltage rating and tolerance as called for in the parts list.

When installing new parts they should be placed in the same position as the original, and the leads should be cut to the same length.

ALIGNMENT NOTES

This receiver has been thoroughly inspected and tested at the factory, using the most modern test equipment available, such as FM sweep generators and oscilloscopes. All R.F. and I.F. circuits have been accurately adjusted at the factory and no attempt should be made to realign these circuits unless it is absolutely necessary.

EQUIPMENT USED FOR ALIGNMENT

- Vacuum tube voltmeter.
- AM Signal generator
- FM Sweep generator.
- Oscilloscope.
- Insulated screw driver.
- Dummy antenna:
 - .1 MFD condenser
 - .00025 MFD mica condenser
 - 150 ohm resistor (2)
- Output meter.

VOLTAGE CHART

	PIN 1	PIN 2	PIN 3	PIN 4	PIN 5	PIN 6	PIN 7	PIN 8	PIN 9
6BE6 FM & AM OSC AM CONV	0	0	0	6 AC	155	125	0		
12AT7 FM RF AMP & CONV	170	0	1.5	0	0	155	0	1	6 AC
6BA6 1st IF AM & FM	0	0	0	6 AC	150	100	0		
6BA6 2nd IF FM	0	0	0	6 AC	155	110	1		
6AL5 FM DETECTOR	0	0	0	6 AC		0	0		
6AT6 AM DETECTOR, AVC, AUDIO	-.5	0	0	6 AC	0	0	60		
6AQ5 POWER OUTPUT	0	7.5	0	6 AC	215	170	0		
6x4 POWER RECTIFIER	230 AC	0	0	6 AC	235	230 AC	235		

Band Switch on AM position. Dial 1600 KC. No Signal.

All voltage readings are taken from tube pin to chassis.

All measurements are made with no signal, using a 20,000 ohm per volt meter.

AC input voltage must be maintained at 117 volts for accurate readings.

AC voltages shown are at 1000 ohms per volt.

All voltages shown are approximate.

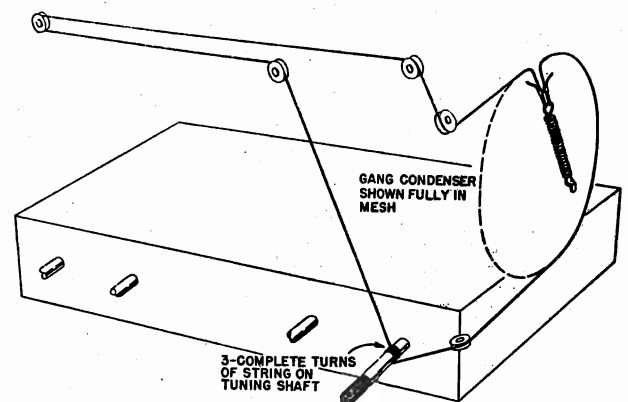

FIG. 4 DIAL CORD STRINGING

MODEL 350-C

ALIGNMENT PROCEDURE

STEPS	RECEIVER DIAL SETTING	BAND SWITCH POSITION	SIGNAL GENERATOR FREQUENCY	DUMMY ANTENNA	SIGNAL GENERATOR CONNECTIONS	OUTPUT INDICATOR	TRIMMER ADJUSTMENT	TRIMMER FUNCTION	REMARKS
1	Minimum capacity	AM	455 KC 400 cycle AM	.1 MFD	High side—grid of AM converter tube (6BE6) Low side—chassis	Output Meter across voice coil	T2 & T4	AM I.F.	Adjust for maximum output
2	"	"	1600 KC 400 cycle AM	"	"	"	AM OSC	AM Oscillator	"
3	1400 KC	"	1400 KC 400 cycle AM	.00025 MFD	High side—One ant. terminal Low side—Other ant. terminal	"	Ant Loop	AM Antenna	"
4	Any position where there is no station interference.	FM	10.7 MC unmodulated .1 volt output.	.1 MFD	High side—grid of 2nd I.F. amplifier tube (6BA6) Low side—chassis	Connect V.T.V.M. to plate of Ratio Detector tube, pin 7 (6AL5)	Top T5	Ratio detector primary	Adjust for maximum negative voltage
5	"	"	10.7 MC 400 cycle 250 KC Deviation	"	"	Connect scope to audio take-off point (across vol. cont.)	Bottom T5	Ratio detector secondary	Adjust for a balanced pattern on scope. See Fig. 2
6	"	"	10.7 MC 400 cycle 80 KC Deviation	"	High side—grid of 1st I.F. amplifier tube (6BA6) Low side—chassis	"	T3	FM 2nd I.F.	Adjust for maximum gain and best pattern on scope. See Fig. 2
7	"	"	"	"	High side—grid (pin 7) of FM converter tube (12AT7) Low side—chassis	"	T1	FM 1st I.F.	"
8	108.5 MC	"	108.5 MC 400 cycle 30% modulation (22.5 KC deviation)	300 ohms in high side	High side—ant. terminal Low side—chassis	Connect output meter across voice coil	FM OSC.	FM oscillator	Adjust for maximum output
9	105 MC	"	105 MC 400 cycle 30% modulation (22.5 KC deviation)	"	"	"	FM RF	FM R.F.	"

FIG. 3 TUBE AND TRIMMER LOCATIONS

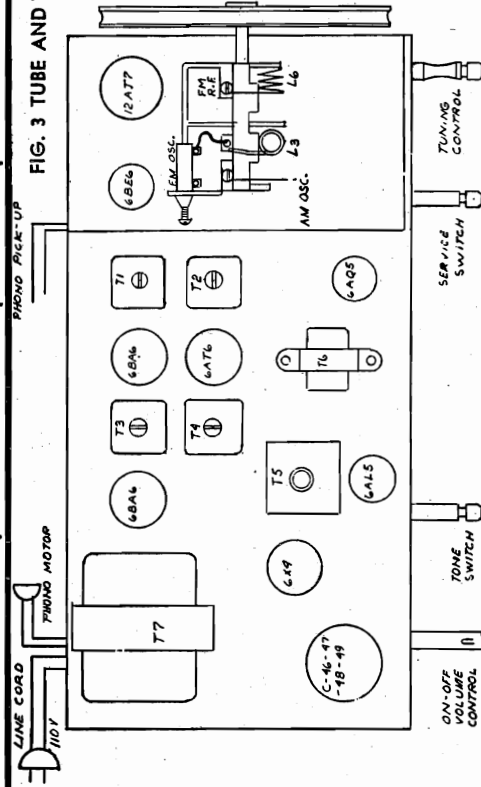

NOTE A: When aligning the FM I.F. circuits, keep the output from the signal generator as low as possible.

FIGURE 2

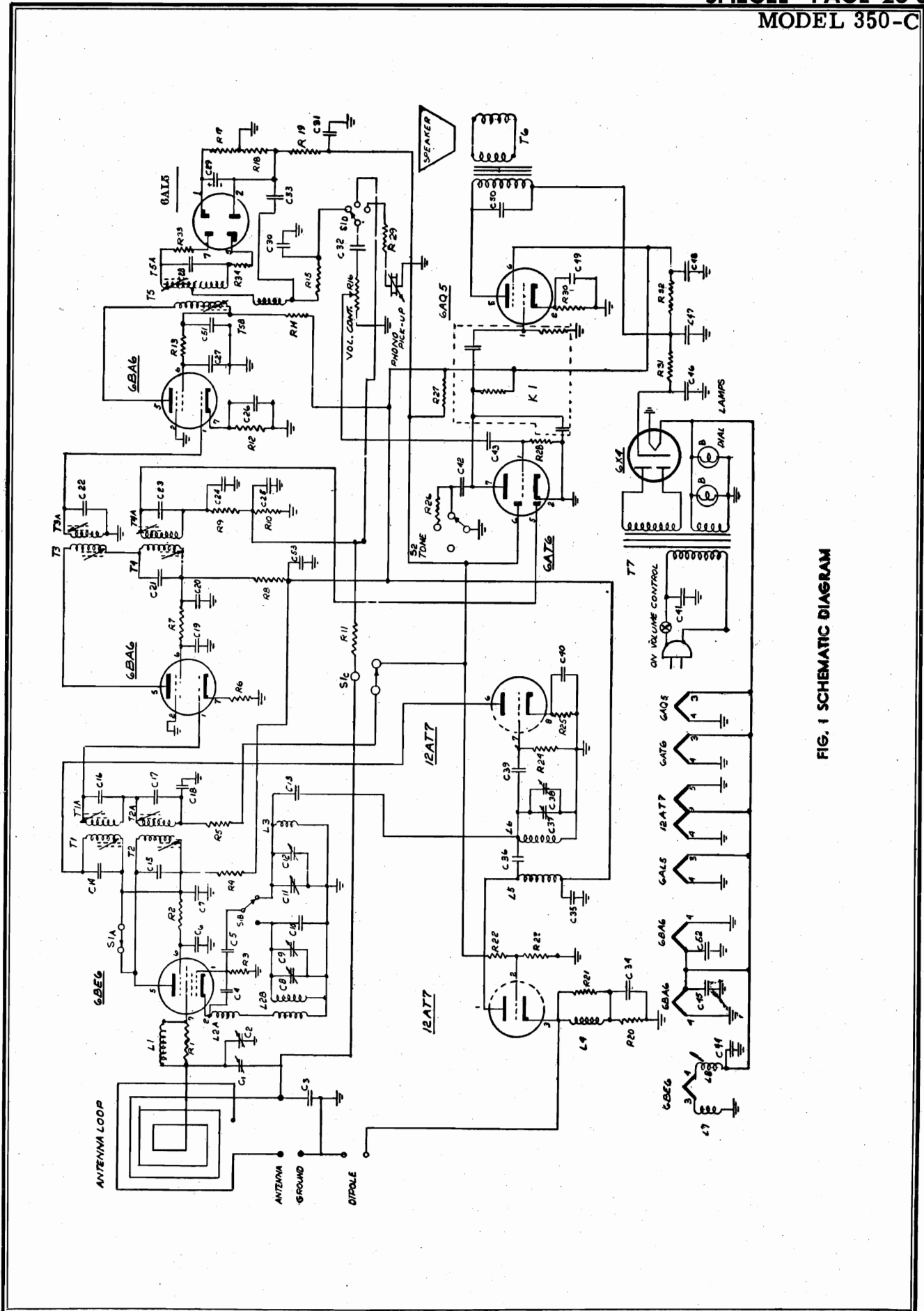

FIG. 1 SCHEMATIC DIAGRAM

MODEL 350-C

PARTS LIST

Schematic Diagram Reference	Description	Price
C1	Loop Trimmer.....	.35
C2	Variable Cond.....	2.55
C8, C9		
C11, C37		
C38	.05-200V Condenser.....	.15
C3		
C4	2.2 MMF Gimmick Cond.....	.15
C5	33 MMF (Erie Style A N14004).....	.15
C6, 18		
C19, 27		
C26, C30		
C42, C45, 51		
C50, C52	5000 MMFD GMV.....ea.	.15
C10	15 MMFD + or - 10% O° T.C. (Erie).....	.15
C12	FM Osc Trimmer.....	.25
C13	1.5 MMFD (Erie Style "A").....	.15
C14, 15, 16, 17	XFMRS	
C21, 22, 23, 24, 28	Integral part of respective IF	
C31, 32, 53, 7, 20	10,000 MMFD GMV.....ea.	.15
C25, 33		
C36, 39	100 MMF ceramic cond.....ea.	.15
C29	4 - 50V Lytic condenser.....	.40
C34, 35		
40, 44	1000 MMFD GMV condenser.....ea.	.15
C41	.1 - 400V condenser.....	.15
C43	.01 - 200V condenser.....	.15
C46, 47	40-350V, 30-300V FP Lytic Condenser.....	2.30
48, 49	30-300V, 10-25V	
R2	4.7K ohm Resistor.....	.10
R3, R15	22K ohm Resistor.....	.10
R4, R8, R14	1K ohm Resistor.....	.10
R5, R19	100K ohm Resistor.....	.10
R6, R12	68 ohm Resistor.....	.10
R7, R13	10K ohm Resistor.....	.10
R9, R26	47K ohm Resistor.....	.10
R10, R23, R24	470K ohm Resistor.....	.10
R11, R22	2.2M ohm Resistor.....	.10
R16	.5M Vol. Cont. - SPST.....	1.20
R17, R18	12K Resistor.....	.10

R20	220 ohm Resistor.....ea.	.10
R33		
R34		
R25	2.2K ohm.....	.10
R27	3.3M ohm.....	.10
R28	6.8M ohm.....	.10
R30	270 ohm - 1 Watt.....	.15
R31	100 ohm - 1 Watt.....	.15
R32	1000 ohm - 5 Watt.....	.30
K1	CRL Triode couplate.....	.50
L1	AM Grid Choke on R1.....	.30
L2A, B		
L3	AM Osc. Coil.....	.30
L4	FM Osc. Coil.....	.30
L5	FM Cathode choke on R21.....	.30
L6	FM plate choke.....	.30
L7, 8	FM RF Coil.....	.30
T1	Filament choke.....	.30
T2	1st FM IF.....	1.50
T3	1st AM IF.....	1.50
T4	2nd FM IF.....	1.50
T5	2nd AM IF.....	1.50
T6	Ratio Detector.....	2.00
T7	Out Put XFMR.....	1.25
B	Power XFMR.....	4.50
	Loop Ant.....	1.50
	No. 44 Pilot Light.....	.20
	Line cord.....	.25
	300 ohm Line Di-Pole Ant.....	1.50

HOW TO ORDER REPAIR PARTS

Always give the part No. (No. printed on the part if different from that shown on this list), and the name of the part. When No. is not available, give complete description of part. Be sure to always give the Model No. and Catalog No. The Model No. will be found on a printed label which will be found at the back of the cabinet.

Values of Capacitors in MFD. unless otherwise stated.
Tolerance on Capacitors and Resistors + or - 20% unless otherwise stated.
All above prices subject to change without notice.

K=1000
M=1,000,000
All Resistors 1/2 Watt unless otherwise noted.

OPERATION

This Aircastle 3-way portable radio is designed to operate on self-contained batteries or 110-120 volt, 60 cycle AC or DC current.

It has a high efficiency built-in antenna; no outside aerial or ground is necessary. Because this type antenna is highly directional and to obtain the best possible reception with a minimum of noise, it may be necessary to turn the set to a position whereby the antenna is at a 90° degree angle to the direction of the station - this is the position of the clearest and best reception.

Do not place near a hot radiator or stove. Give set reasonable care and it will add many happy hours to your listening pleasure -- at home or away.

TO OPERATE ON AC OR DC HOUSE CURRENT: Plug power cord into wall outlet in normal manner. Turn on-off volume control until click is heard - this turns on the power. Continue turning control about half way of range. Adjust tuning control to the station of your choice for best clarity of reception. Re-adjust volume to desired level.

NOTE: If slight hum is heard when operating with AC current, or if no signal is heard when operating on DC current, reverse power plug into power outlet.

TO OPERATE ON BATTERY: Plug power cord into slot at back of chassis. Operation of set is then same as operating on house current. Caution: To get the most service from your battery, turn off set when not being used.

BATTERY PACK REPLACEMENT

This set used type 90V-9V battery pack. When replacing, it is suggested that you observe how old battery is placed and connect new battery pack in same manner.

ALIGNMENT DATA

Step	Connect high side of Signal Generator to:	Signal Generator output	Dial Pointer Setting	Adjust for Maximum output
#1	1R5 pin #7 through 0.1 mfd condenser	455 KC	To high end of dial where signal is unaffected	1st IF Transformer (L4) 2nd IF Transformer (L5)
#2	Couple to receiver loop with several turns of wire.	1620 KC	Minimum capacity	Oscillator trimmer
#3	Same as above	1400 KC	Tune to signal	RF Transformer (L2) Antenna section trimmer

- a) Measure output with output meter across speaker voice coil.
- b) Signal Generator output should be kept as low as convenient to give reading without overload and without AVC action.

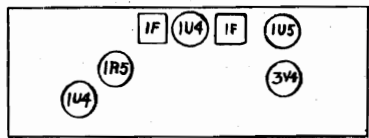
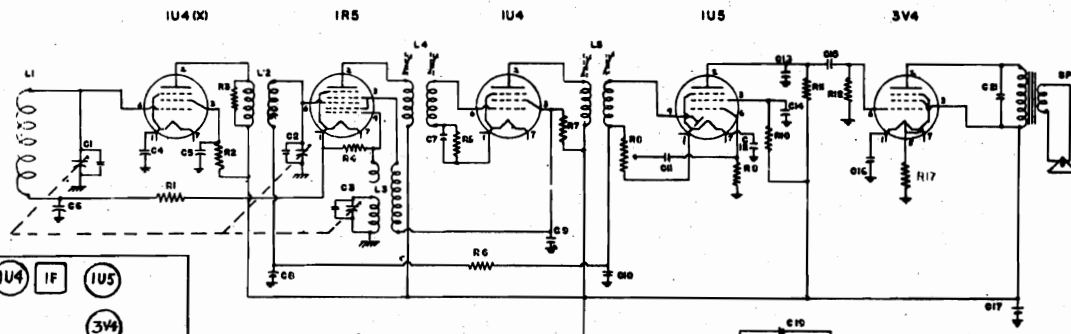

LEGEND		
C1 ANT VARIABLE	C19 .2MFD 600V.	R3 2000 OHM 1/2 W.
C2 R.F. VARIABLE	C20 40MFD 150V.	R4 100K OHM 1/2 W.
C3 OSC. VARIABLE	C21 .002 MFD 500V.	R5 3.3 MEGOHM 1/2 W.
C4 .2 MFD. 200V.		R6 2.2 MEGOHM 1/2 W.
C5 .005 MFD 500V.	SP 5 IN. SPEAKER	R7 8200 OHM 1/2 W.
C6 .005 MFD 500V.	SR SELENIUM RECTIFIER	R8 1 MEG VOL. CON.
C7 .01 MFD 500V.	S1 BATT.-A.C. SWITCH	R9 10 MEGOHM 1/2 W.
C8 .05 MFD 200V	S2 ON-OFF SW. ON V.C.	R10 4.7 MEGOHM 1/2 W.
C9 .05 MFD 200V		R11 220K OHM 1/2 W.
C10 100MMF 250V	L1 ANT. LOOP	R12 1 MEGOHM 1/2 W.
C11 .002 MFD 200V	L2 R.F. COIL	R13 1500 OHM 1/2 W.
C12 .05 MFD 200V.	L3 OSC. COIL	R14 47 OHM 1 W.
C13 100MMF 250V.	L4 I.F.	R15 2700 OHM 1 W.
C14 .01 MFD 500V	L5 I.F.	R16 2200 OHM 8 W.
C15 .002 MFD 200V		R17 1000 OHM 1/2 W.
C16 200 MFD 25 V.	R1 470K OHM 1/2 W	R18 1000 OHM 1/2 W.
C17 40 MFD 150 V.	R2 8200 OHM 1/2 W.	R19 1000 OHM 1/2 W.
C18 .05 MFD 400V		

BATTERY PACK 9VA 90VB EVEREADY NO 756 OR EQUIV.

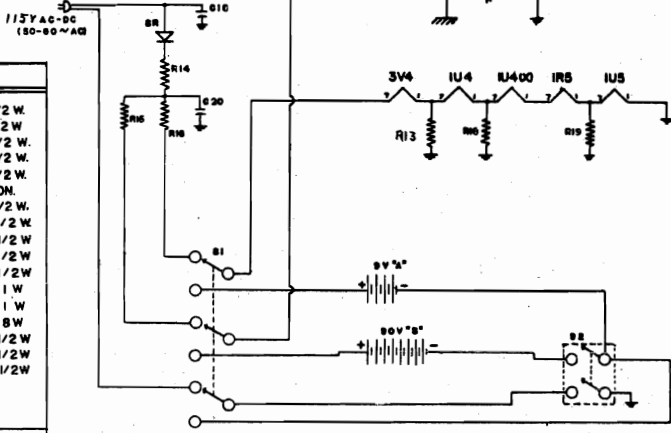

HOW TO ORDER PARTS

Always specify the following on your order blank:

ITEM FOR WHICH PART IS ORDERED	MODEL NUMBER	PART NUMBER	DESCRIPTION	QUANTITY	PRICE
--------------------------------	--------------	-------------	-------------	----------	-------

PARTS LIST

SYMBOL NO.	PART NO.	DESCRIPTION	PRICE*
C1, C2, C3	CV-29	Variable Condenser	2.30
C17, C20	CE-1003C	Electrolytic 40mfd/150V	1.20
		Any condenser, paper, (specify value)	.15
		Any Discap condenser (specify value)	.15
	CCT-100-25	Ceramic Tubular condenser	.12
		Any resistor, carbon, (specify value)	.15
R16	RW1951	Resistor, wire wound	.60
T	TR103	Output Transformer	1.40
SP	SP42A	Speaker less/trfr	3.60
L1	LPFE-11A	Loop Antenna	.80
L2	LC12	RF Coil	.60
L3	LC11	Oscillator Coil	.60
L4, L5	LF24	IF Transformer	.90
S1	SWSS-6	Slide Switch	.60
SR	SE1000	Selenium Rectifier	1.20
	CB-6P2E	Cabinet for model 652.6P2E	3.60
	KNV-6P2	Knob, Volume, on, off	.60
	KNT-6P2	Knob, Tuning	.60
R8	VC-53	Volume Control	1.20

*Prices subject to change without notice

INSTALLATION

Your new Aircastle AM-FM receiver is designed for use on AC 60 cycle or DC current of 105-120 volt. If you are in doubt of the current supply in your locality, consult your power company.

When operating on DC current source, it is necessary to insert the power plug with the proper polarity. If the set fails to function after an interval sufficient for the tubes to reach their operating temperature, reverse the power plug in the outlet.

If operating on AC current and a slight hum is heard, reverse the power plug in the outlet as this may be pick-up interference from your power source.

Do not use an external ground with this receiver. Do not place receiver near a hot stove or radiator as it might damage set.

ANTENNA

This receiver has a high efficiency built-in AM antenna. For most locations and under normal receiving conditions, this antenna will be adequate to provide excellent results.

For FM reception, this set has a line antenna which will provide satisfactory reception in most localities.

However, for best possible reception regardless of location from stations, an external FM antenna should be used. Any FM antenna with a 300 ohm line may be used and should be placed as high as possible to overcome any obstruction that might impair reception. The two-lead-in wires of the antenna should be attached (one lead to each screw) to the terminal strip located on the cabinet back after detaching the small wire that was between the two screws on terminal block when set was shipped.

TO OPERATE

To turn the receiver on, rotate on-off volume switch (outer-most knob) until it clicks. Continue rotating knob to about half of its range allowing set to reach its operating temperature. Then turn station selector knob to the desired station. It is always recommended that you tune the station with the volume control set low as this enables you to get the exact point where the station comes with maximum volume and clarity - this is particularly true of FM reception.

To select the AM or FM band, it is necessary to turn the inner-most knob located on the volume control to the right for the AM band; to the left for FM band.

SERVICE NOTES

When installing new parts they should be placed in the same position as the original, and the leads should be cut to the same length. Lack of sensitivity and poor tone quality may be due to any one or a combination of causes, such as weak or defective tubes or speaker, open or grounded resistors, or bypass condensers. Never attempt to realign the set until all other possible sources of trouble have been first thoroughly investigated and definitely proved not to be the cause. It will be necessary to follow the procedure outlined below and to use recommended equipment for satisfactory results.

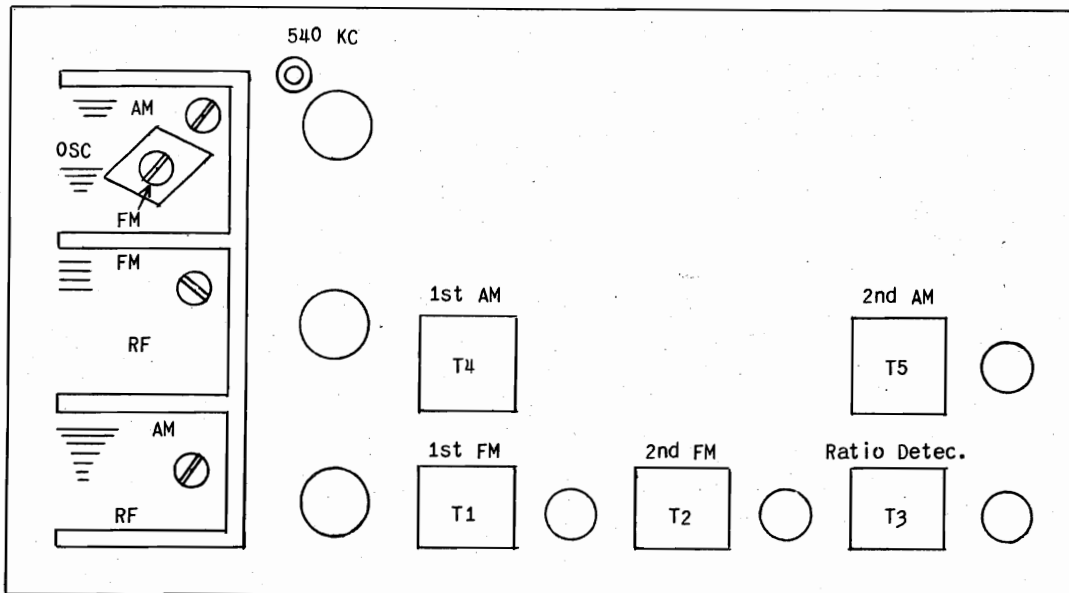

FM Oscillator and RF coils directly below associated section of variable condenser.

AM ALIGNMENT PROCEDURE

Measure output across speaker voice coil with output meter.

Step	Connect high side of signal generator to:	Signal Generator setting:	Dial Pointer Setting	Adjust for maximum output
#1	12BE6, pin #7 through 0.1 mfd condenser	455 KC	At high end of dial where signal is unaffected	2nd AM IF transformer T5 1st AM IF transformer T4
#2	Couple to receiver loop antenna with several turns of wire.	1620 KC	Minimum capacity	AM oscillator trimmer condenser
#3	Same as above	540 KC	Maximum capacity	Adjust slug in 540 KC coil
#4	RECHECK	Step #2		
#5	Same as above	1400 KC	Tune to signal	AM antenna section trimmer condenser

FM ALIGNMENT PROCEDURE

Step	Connect high Side of Signal Generator	Signal Generator Setting	VTVM Connection	Adjustment	Output Indication	Remarks		
IF ALIGNMENT	1	12AT7 pin #2 through 0.1 mfd condenser	10.7MC	19T8 pin #2	2nd FM IF Transformer T2 1st FM IF Transformer T1 Bottom slug <u>only</u> of ratio detector trans. T3	Adjust for maximum output indication on VTVM	Reduce signal generator output so that no more than 2.0 volts output is measured on VTVM	Refer to tube layout chart and schematic for location of trimmers.
	2	Make up network of two 6.8K resistors as shown on schematic and connect across points X-X as indicated.						
	3	Same as in step #1	10.7MC	High side to point "Z" on schematic. Low side to point labeled "Y".	Top slug <u>only</u> of ratio detector trans. T3	Adjust for zero reading on VTVM.		
	4	Remove resistor network of step 2					Tune Receiver	
RF ALIGNMENT	5	Connect sweep generator to FM antenna terminals of receiver with 150 ohm resistor in series with each lead.	87.6 MC ± 75KC deviation 400 cps.	Output meter across speaker voice coil.	Expand or compress oscillator coil.	Adjust until max. signal is obtained on output meter	Maximum capacity (fully meshed)	
	6	"	108.4MC ± 75KC @ 400cps	"	FM oscillator trimmer condenser	Adjust for maximum signal	Minimum capacity	Recheck step 5
	7	"	90 MC ± 75KC @ 400 cps	"	FM-RF coil expand or compress	Adjust for maximum signal	Tune to signal	
	8	"	105 MC ± 75 KC @ 400 cps	"	FM-RF trimmer condenser	Adjust for maximum signal	Tune to signal	Recheck Step 7

MODEL 652.8TF1

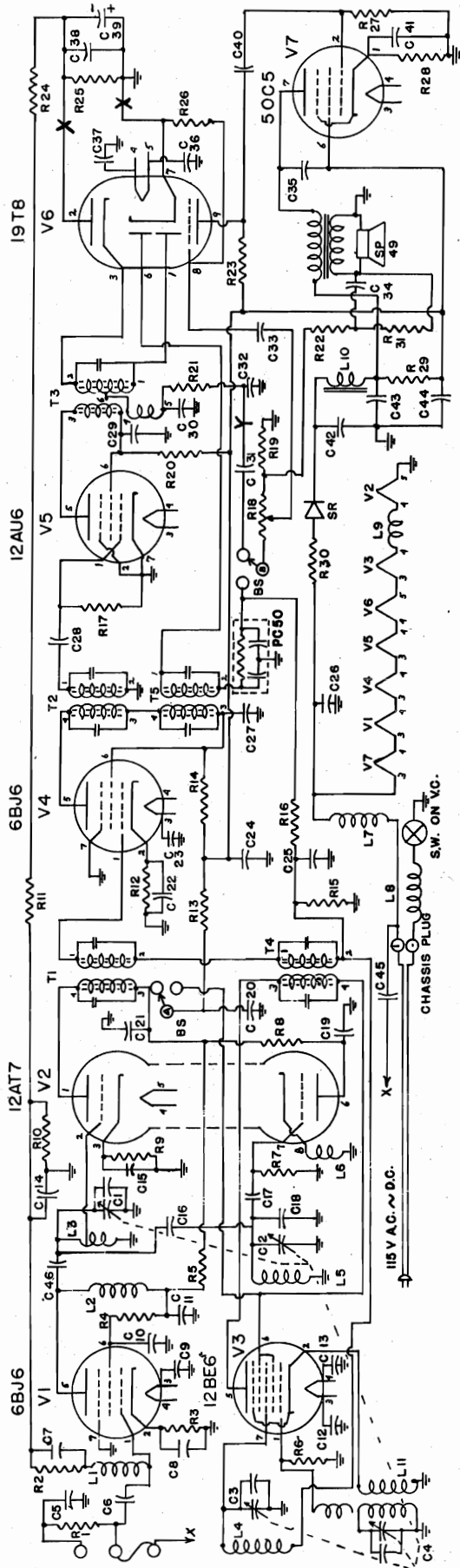

TUBE LAYOUT

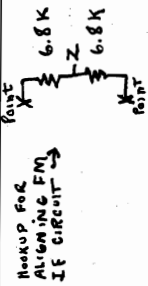

PARTS LIST

C 1,2,3,4	VARIABLE CONDENSER	R 1	1500 OHM	10% 1/2 W	PC 50	100mmf cap. (2)
C 5,6,7,17,28	500 V	R 2	100 K OHM	10% 1/2 W	L 1,2,6,9	470 K ohm res. (1)
46.		R 3, 12	68 OHM	10% 1/2 W	L 3	R.F. CHOKE 10PH(LC22)
C 8,15	1500mmf	R 4, 5	220 OHM	10% 1/2 W	L 4	R.F. COIL F.M.
C 9,10,12,13,		R 6, 25	22K OHM	10% 1/2 W	L 5	LOOP ANTENNA
14,21,23,24,		R 7	22K OHM	5% 1/2 W	L 7,8	OSC COIL F.M.
35,36,37,38	.005mfd	R 8,13,14,20	470 OHM	10% 1/2 W	L 10	R.F. CHOKE 2.7 Ph(LC33)
C 11,19,20,22		R 9, 11, 19	1K OHM	10% 1/2 W	L 11	CHOKE 70PH
27,29,31,33,		R 10, 31	10K OHM	10% 1/2 W	T 1,2, 3	OSC COIL A.M.
40	.01 mfd	R 15	3.3 MEGOHM	10% 1/2 W	T 4,5	I.F. F.M. 51,52,53
C 16	2mmf	R 16	2.2 MEGOHM	10% 1/2 W	SR	I.F. A.M. 55
C 18	3-12mfd SILVER MICA TRIMMER	R 17, 27	470K OHM	10% 1/2 W	BS	100 Ma. SEL. RECT.
C 25, 26	400 V	R 18	0.5 MEGOHM	Volume control	SP 49	A.M. ~ F.M. Band switch on VC.
C 30	390mmf	R 21	27K OHM	10% 1/2 W		SPEAKER W/x former
C 32	.002mfd	R 22	6.8 K OHM	10% 1/2 W		
C 34	.1mfd	R 23	390K OHM	10% 1/2 W		
C 39	4mfd Electrolytic	R 24	220K OHM	10% 1/2 W		
C 41	10mfd "	R 26	4.7MEGOHM	10% 1/2 W		
C 42,43	40mfd "	R 28	150 OHM	10% 1 W		
C 44	20mfd "	R 29	470 OHM	10% 1 W		
C 45	10 mm f	R 30	22 OHM	10% 1 W		

HOW TO ORDER PARTS

ALWAYS SPECIFY The following information on your repair part order blank.

Item for Which Part is Ordered	Model No.	Part No.	Description Of Part And Finish	Quantity Wanted	Price of Each Part	Total Price
--------------------------------	-----------	----------	--------------------------------	-----------------	--------------------	-------------

PARTS LIST

SYMBOL NO.	PART NO.	DESCRIPTION	PRICE
C1, -2, -3, -4	CV 24	Variable condenser	\$ 3.00
C 39	CE-1008	Electrolytic, 4mfd, 25V	.60
C 41	CE-1009	Electrolytic, 10mfd, 25V	.60
C42, C43, C44	CE-1014C	Electrolytic, 40-40-20mfd/150V	1.20
PC 50	PC 50	Filpac	.12
		Any Condenser, Paper, Mica, Ceramic (Specify Value)	.15
		Any Resistor (Specify Value Desired)	.12
R 18	VC 40	Volume Control/W Switch	2.60
SR	SE 1001	Selenium Rectifier	1.60
SP	SP 49	Speaker W/Transformer	4.40
L4		AM Loop Antenna	.80
L11	LC 32	AM Oscillator Coil	.43
L3	LC 29	RF Coil, FM	.30
LS	LC 28	FM Oscillator Coil	.30
T1	IF 51	IF Transformer (FM)	
T2	IF 52	" " "	
T4, T5	IF 55	IF Transformer (AM)	
T3	IF 53	Ratio Detector Transformer Cabinet (Mahogany) Specify for Model 652.8TF1M	3.60
	CC-8TF1	Grille Cloth	.60
	DL 71	Dial Scale	1.20
	M5 D11	Decorative Panel Strip	.45
		Knobs (Specify - Band Switch, Volume or Tuning)	.30
V1, V4		6BJ6	2.10
V2		12AT7	2.90
V3		12BE6	1.90
V5		12AU6	1.80
V6		19T8	2.90
V7		50C5	2.00

PRICES SUBJECT TO CHANGE WITHOUT NOTICE.

MODELS 610. CL152B,
610. CL152M

3. Select your favorite program by turning the TUNING CONTROL knob, located at the right hand side of your clock radio. The numbers on the dial above the TUNING CONTROL knob correspond to the frequency of the standard broadcasting stations. The last two numbers of the frequency have been omitted for simplicity.

4. Shut the radio off by turning the OPERATION SELECTOR knob at the left hand side of the clock face to "OFF."

WAKE UP TO MUSIC:

1. Set the radio dial for the program you wish to hear in the morning and adjust the sound volume for pleasant listening.

2. Pull out the ALARM SET knob at the right hand side of the clock face. This knob is marked "ON PULL" and "OFF PUSH." Turning the ALARM SET knob to the left rotates the numbered disk underneath the clock hands. Just turn the knob until the small pointer opposite the hour hand is over the time you would like the radio to wake you in the morning.

3. After setting the alarm you may continue normal radio listening by turning the OPERATION SELECTOR switch to the "ON" position. At bedtime turn the OPERATION SELECTOR switch so that the knob pointer is turned to "AUTO." Your radio will then be turned on automatically at the time selected.

4. A buzzer alarm will sound a few minutes after the radio goes on and will continue to sound until the ALARM SET knob is pushed in. You may push in the ALARM SET knob at any time if you do not want the buzzer alarm to sound.

AS AN ALARM CLOCK: Your AIRCASTLE Clock-Radio can be used as a regular alarm clock. Set the "ALARM SET" pointer several minutes ahead of the time you wish the buzzer to sound. Leave the ALARM SET knob pulled out and set the OPERATION SELECTOR to the "OFF" position upon retiring. When the alarm buzzer sounds it may be turned off by simply pushing the ALARM SET knob inward.

INSTALLATION: Your new Aircastle Clock-Radio is ready to operate when plugged into any 105-125 volt 60 cycle AC only power line. The newly designed "Magna-Loop" antenna built right into the radio will pick up radio signals in almost any location. Do not connect a ground to the radio at any time.

CLOCK-RADIO OPERATIVE CONTROLS

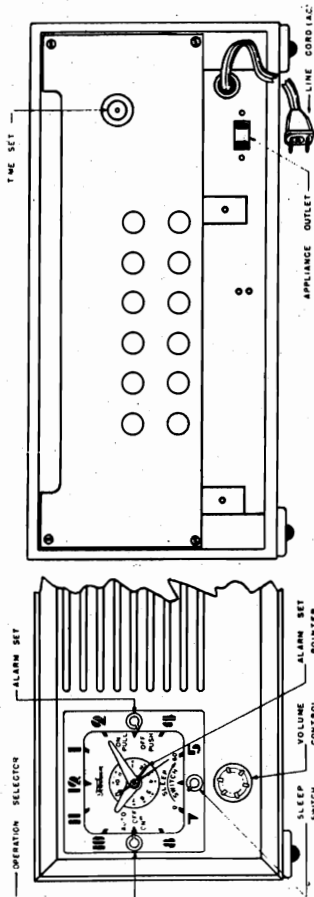

AS A CLOCK: Your clock starts automatically when the plug is inserted into the proper outlet. The knob extending through the hole at the back of the set provides a convenient means of setting the clock. To set the time turn the knob to the right. Your clock should not require readjustment except when removed from the outlet or in case of failure of the electric power.

AS A RADIO:

1. Turn the OPERATION SELECTOR knob, located at the left hand side of the clock face, to the "ON" position. Allow a few seconds for the radio to warm up.

2. The VOLUME CONTROL knob is located directly below the clock. Turn the knob to the right for increased volume. Turning the VOLUME CONTROL knob to the left decreases the volume. The volume should never be reduced by detuning the TUNING CONTROL knob.

MODELS 610. CL152B,
610. CL152M

GO TO SLEEP WITH MUSIC:

1. Select the program you would like to go to sleep to and adjust the volume.
2. A scale marked from 0 to 60 and a "SLEEP SWITCH" are located at the bottom of the clock face. Set the "SLEEP SWITCH" by turning the knob pointer to whatever fraction of an hour you want to keep the radio playing. The radio will be turned off in one hour when the pointer is turned all the way to 60. Thirty minutes would be one-half way. To turn the radio off in 15 minutes set the knob pointer one-quarter of the distance from 0 to 60.
3. Turn the "OPERATION SELECTOR" to "AUTO" if you wish to go to sleep and wake up to music. If you do not want the clock-radio to awaken you turn the "OPERATION SELECTOR" to the "OFF" position.

TO TURN ON APPLIANCES AUTOMATICALLY: A convenient outlet plug has been provided at the back of your AIRCASTLE Clock-Radio to turn on any of your appliances, such as a toaster, coffee maker, etc., not exceeding 1100 watts.

1. Turn the "ALARM SET" pointer to the time you would like your appliance to start operating. If the alarm buzzer is not desired, push the ALARM SET knob inward.
2. Turn the OPERATION SELECTOR knob to the "AUTO" position.
3. Insert the plug of your electrical appliance into the outlet plug on the back of your AIRCASTLE Clock-Radio.
4. Turn on your electrical appliance switch.

AS AN ELECTRICAL APPLIANCE TIMER: Your AIRCASTLE Clock-Radio can be used to time appliances, such as coffee makers, electric roasters, television receivers, etc.

1. Plug the electric appliance into the appliance outlet on the back of your clock-radio.
2. Adjust the ALARM SET pointer to the time the appliance is to be turned on within a 12-hour period. If you wish the alarm buzzer to sound leave the ALARM SET knob pulled out.

3. Turn OPERATION SELECTOR knob pointer to "AUTO."
4. Turn on the switch of your electrical appliance.
5. As soon as the appliance starts, set the SLEEP SWITCH for whatever period between one and 60 minutes that you would like the appliance to continue operating. Then turn the OPERATION SELECTOR to the "OFF" position.

AROUND THE CLOCK WITH YOUR CLOCK-RADIO: You will also find countless other ways to time your cooking and appliance operations all through the day ... Your clock-radio is fully AUTOMATIC...An electronic helper in your home...saving you many minutes every minute of the day.

ELECTRICAL SPECIFICATIONS

Power Supply105 to 125 volts This receiver contains the 60 cycles AC only following tubes:
 Frequency Range....538 to 1650 KC 1-12BE6...Mixer
 1-12BA6...I.F. Amplifier
 1-12AT6...Detector-AVC-1st Audio
 1-50C5.....Power Output
 1-35W4.....Rectifier

SERVICE NOTES

Voltages taken from different parts of the circuit to the common ground above chassis are measured with volume control in maximum position, all tubes in their sockets, no signal applied, and with a voltmeter having a resistance of 20,000 ohms per volt. All voltages should be measured with an input voltage of 118 volts AC only. To check for open bypass condensers, shunt each condenser with a known good condenser of the same capacity and voltage rating.

MODELS 610.
CL152B,
610. CL152M

ALIGNING INSTRUCTIONS

Never attempt any adjustments on this receiver unless it becomes necessary to replace a coil or transformer, or the adjustments have been tampered with in the field. Always make certain that other components, such as tubes, resistors, condensers, etc., are normal before proceeding with re-alignment. If re-alignment is necessary follow the instructions on page 6 under the heading "Alignment Procedure." After the re-alignment has been completed, repeat the procedure as a final check.

To remove the chassis for servicing, remove the three chassis screws from the bottom of the cabinet and remove the cabinet back, volume control knob and tuning knob. Remove the bracket securing the clock to the cabinet and slide out the chassis and clock.

ALIGNMENT PROCEDURE

Volume Control -- Maximum, all adjustments. No signal applied to antenna.

Power Input -- 105 to 125 volts, 60 cycle AC.

Connect dummy antenna in series with output lead of signal generator.

Connect ground lead of signal generator to common ground above chassis.

Repeat alignment procedure as a final check.

The following equipment is necessary for proper alignment.

Signal generator that will provide the test frequencies as listed, modulated 400 cycles, 30%.

Non-metallic screwdriver.

Output meter.

Dummy antenna -- .1 MFD condenser.

For alignment points refer to Schematic Diagram

DIAL SETTING	GENERATOR FREQUENCY	DUMMY ANTENNA	GENERATOR CONNECTION	TRIMMER REFERENCE	TRIMMER ADJUSTMENT	TRIMMER FUNCTION
1. Fully open	455KC	.1 MFD	12BE6 Grid	L3 Top & Bot.	Maximum	Output I. F.
2. Fully open	455KC	.1 MFD	12BE6 Grid	L2 Top & Bot.	Maximum	Input I. F.
3. Fully open	1650KC	.1 MFD	12BE6 Grid	CV2	Maximum	Oscillator
4. Tune in signal from generator	1400KC		Loosely couple signal generator to "Magna Loop"	CV1	Maximum	Antenna R. F. Trimmer

TUBE PLACEMENT AND ALIGNMENT CHART

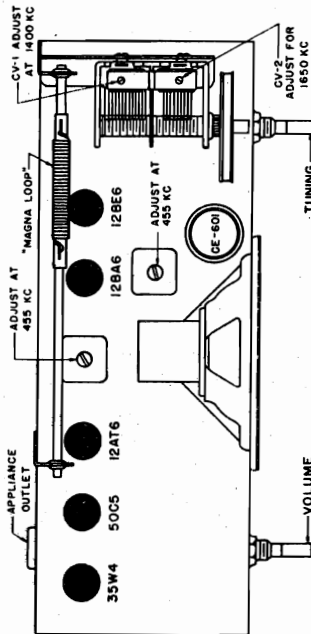

MODELS 610. CL152B,
610. CL152M

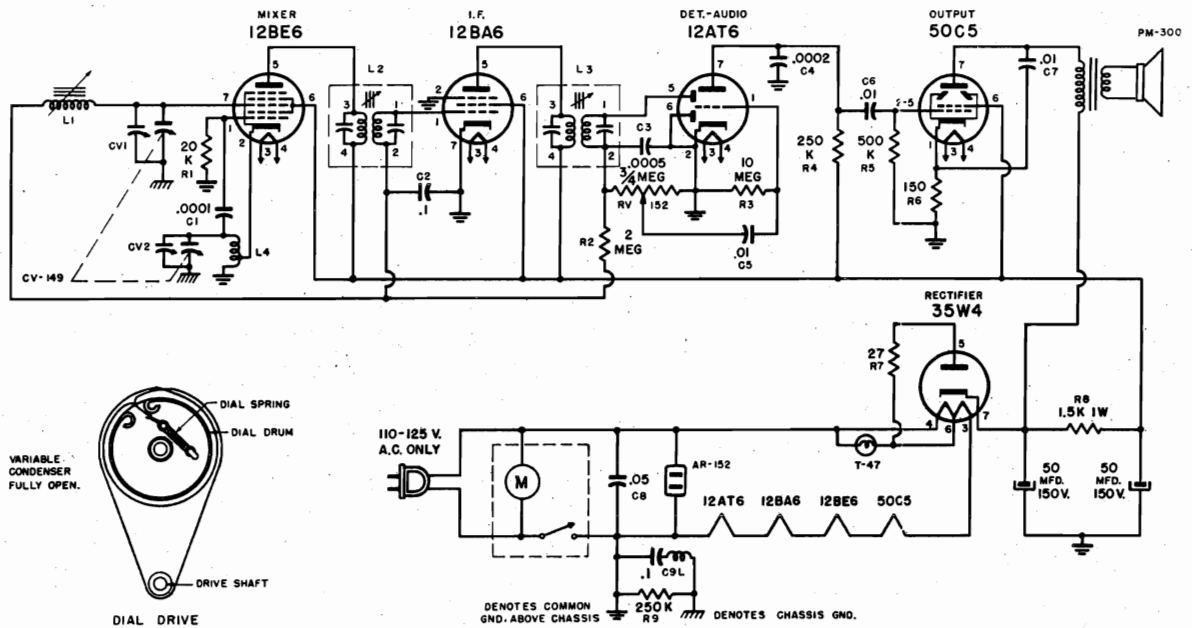

PARTS LIST

SCHEMATIC NUMBER	PART NUMBER	DESCRIPTION	PRICE
CONDENSERS			
C1	CC200	100 MMFD Ceramic	\$.25
C2	C208	.1 MFD 400 volt	.35
C3	CC500	500 MMFD Ceramic	.25
C4	CC201	200 MMFD Ceramic	.25
C5, C6, C7	C206	.01 600 volt	.30
C8	C204	.05 400 volt	.35
C9L	C14L	.1 MFD 400 volt condenser-choke assbly.	.50
CE-601	CE-601	Dual 50 MFD 150 volt electrolytic	2.50
CV1, CV2	CV-149	2 section variable	2.75
RESISTORS			
R1	R306	20 K ohm 1/2 watt 20%	.10
R2	R310	2 megohm 1/2 watt 20%	.10
R3	R311	10 megohm 1/2 watt 20%	.10
R4, R9	R307	250 K ohm 1/2 watt 20%	.10
R5	R308	500 K ohm 1/2 watt 20%	.10
R6	R320	150 K ohm 1/2 watt 20%	.20
R7	R321	27 ohm 1/2 watt 20%	.10
R8	R314	1.5 K ohm 1 watt 20%	.10
RV-152	RV-152	2 megohm volume control	1.00
COILS AND TRANSFORMERS			
L1	L-A51	Magna-Loop Antenna Coil	1.50
L2	1655-16	1st I.F. Transformer	2.00
L3	1655-16	2nd I.F. Transformer	2.00
L4	L201	R.F. Oscillator Coil	1.00
MISCELLANEOUS			
T-47	T-47	Pilot Light	.15
PM-300	PM-300	Speaker, 5" PM, includes Output Transformer	6.40
	H-100	Cabinet	6.00
	H-101	Knob	.20
M	C57G27	Electric Clock	7.50
AR-152	AR-152	Appliance Socket	.40
DIAL PARTS			
	H-102	Dial Pointer	.35
	H-103	Dial Pulley	.05
	H-152	Dial Window	.30
	H-104	String, Dial Drive	.05
	H-105	Spring, Dial Drive String Tension	.10

ALL ORDERS SUBJECT TO PRICES AT TIME OF SHIPMENT

MODEL 472.400

HOW TO INSTALL THE RECEIVER

Your new Radio is a seven tube (plus rectifier) superhetro-dyne FM-AM radio receiver designed for use on 105.125 volts 60 cycle AC only.

It covers the standard AM broadcast frequency range, 540-1600 kilocycles (KC), and the FM frequency range from 88 to 108 megacycles (MC).

This receiver is shipped from the factory complete with 2 built-in loop antennae for standard AM broadcast reception, and FM stations. These antennas will be satisfactory for good reception under normal conditions. Terminals are provided at the back of the radio for connecting external AM and FM antennas, wherever this is found to be desirable as explained below.

When the receiver is to be used under difficult conditions, such as in buildings constructed mainly of steel, or those with steel lath, or, when large buildings, mountains or other objects are between the receiver and the station to be

received, it may be necessary to use an external dipole antenna. Remember too, FM reception is limited as to distance and when used outside the primary service area of the transmitter, an outside antenna is very necessary.

The type of dipole to be used depends on the signal strength of the station in that particular area, as well as conditions of reception as outlined above. There are three types of FM dipole available; the single dipole, the folded dipole and the non directional dipole. The single dipole is bi-directional and will receive stations located within a range of 10 to 15 miles in front or in back of the antenna. The non-directional dipole may be used, as the name implies, when the stations to be received are located in several different directions within a 10 to 15 mile range. The folded dipole with reflector gives maximum efficiency in any one direction and in many instances will double the distance over which satisfactory reception can be had.

SPECIFICATIONS

Power Supply.....	105-125 volts 60 cycle AC only.
Power Consumption.....	65 Watts.
Frequency Range FM.....	88 to 108 MC.
Frequency Range AM.....	540 to 1600 KC.
I.F. Frequency FM.....	10.7 MC.
I.F. Frequency AM.....	455 KC.
Band width, FM, Ratio Detector.....	330 KC.
Band width, FM, 1st I.F.....	280 KC.

The tubes used are as follows:

12AT7	FM RF Amplifier, Converter
6BE6	FM Osc, Am Osc, Converter
6BA6	FM-AM, 1st I.F. Amplifier
6BA6	FM, 2nd I.F. Amplifier
6AL5	FM Detector
6AT6	AM Detector, AVC, Audio
6AQ5	Power Output
6X4	Power Rectifier

SERVICE NOTES

GENERAL

CAUTION: If realignment is necessary be sure the proper test equipment is available, as listed below, before proceeding with the alignment procedure as given

Due to the high frequencies at which FM signals are received the service man must use great care when servicing these sets. Extreme caution must be used regarding the moving of component parts in the R.F. and oscillator circuits of the receiver as those circuits can be detuned in this manner.

If it becomes necessary to replace components such as resistors and condensers they must be replaced with parts of the same size, type, voltage rating and tolerance as called for in the parts list.

When installing new parts they should be placed in the same position as the original, and the leads should be cut to the same length.

ALIGNMENT NOTES

This receiver has been thoroughly inspected and tested at the factory, using the most modern test equipment available, such as FM sweep generators and oscilloscopes. All R.F. and I.F. circuits have been accurately adjusted at the factory and no attempt should be made to realign these circuits unless it is absolutely necessary.

EQUIPMENT USED FOR ALIGNMENT

- Vacuum tube voltmeter.
- AM Signal generator
- FM Sweep generator.
- Oscilloscope.
- Insulated screw driver.
- Dummy antenna:
 - .1 MFD condenser
 - .00025 MFD mica condenser
 - 150 ohm resistor (2)
- Output meter.

ALIGNMENT PROCEDURE

STEPS	RECEIVER DIAL SETTING	BAND SWITCH POSITION	SIGNAL GENERATOR FREQUENCY	DUMMY ANTENNA	SIGNAL GENERATOR CONNECTIONS	OUTPUT INDICATOR	TRIMMER ADJUSTMENT	TRIMMER FUNCTION	REMARKS
1	Minimum capacity	AM	455 KC 400 cycle AM	.1 MFD	High side—grid of AM converter tube (6BE6) Low side—chassis	Output Meter across voice coil	T2 & T4	AM I.F.	Adjust for maximum output
2	"	"	1620 KC 400 cycle AM	"	"	"	C 2A	AM Oscillator	"
3	1400 KC	"	1400 KC 400 cycle AM	.00025 MFD	High side—One ant. terminal Low side—Other ant. terminal	"	C 1A	AM Antenna	"
4	Any position where there is no station interference.	FM	10.7 MC unmodulated .1 volt output.	.1 MFD	High side—grid of 2nd I.F. amplifier tube (6BA6) Low side—chassis	Connect V.T.V.M. to plate of Ratio Detector tube, pin 2 (6AL5)	Top T5	Ratio detector primary	Adjust for maximum negative voltage.
5	"	"	10.7 MC 400 cycle 250 KC Deviation	"	"	Connect scope to audio take-off point (across vol. cont.)	Bottom T5	Ratio detector secondary	Adjust for a balanced pattern on scope. See Fig. 2
6	"	"	10.7 MC 400 cycle 80 KC Deviation	"	High side—grid of 1st I.F. amplifier tube (6BA6) Low side—chassis	"	T3	FM 2nd I.F.	Adjust for maximum gain and best pattern on scope. See Fig. 2
7	"	"	"	"	High side—grid (pin 7) of FM converter tube (12AT7) Low side—chassis	"	T1	FM 1st I.F.	"
8	108.5 MC	"	108.5 MC 400 cycle 30% modulation (22.5 KC deviation)	300 ohms in high side	High side—ant. terminal Low side—chassis	Connect output meter across voice coil	C 8	FM oscillator	Adjust for maximum output
9	105 MC	"	105 MC 400 cycle 30% modulation (22.5 KC deviation)	"	"	"	C 3A	FM R.F.	"

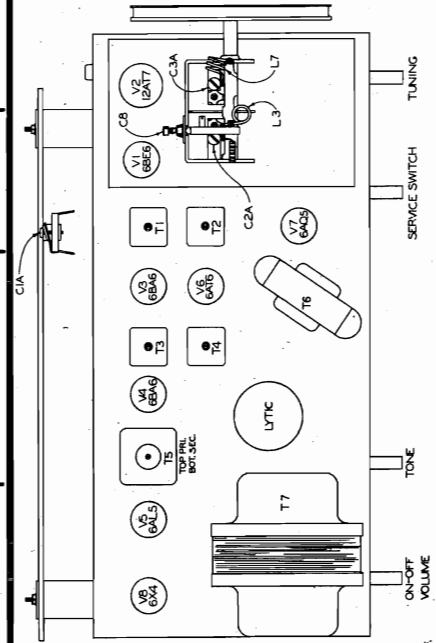

FIG. 3 TUBE AND TRIMMER LOCATIONS

FIGURE 2

VOLTAGE CHART

Tube	PIN 1	PIN 2	PIN 3	PIN 4	PIN 5	PIN 6	PIN 7	PIN 8	PIN 9
V1 - 6BE6	-9.5	0	0	6.3	158	107	-0.3		
				AC					
V2 - 12AT7	170	0	2.1	0	0	158	0	3.5	6.3
									AC
V3 - 6BA6	-0.1	0	6.3	0	158	120	1.1		
				AC					
V4 - 6BA6	0	0	6.3	0	158	115	1.4		
				AC					
V5 - 6AL5	0.1	-0.6	6.3	0	-0.2	0	-0.2		
				AC					
V6 - 6AT6	-0.4	0	6.3	0	-0.5	-0.1	50		
				AC					
V7 - 6AQ5	0	8.6	6.3	0	205	170	0		
				AC					
V8 - 6X4	220	0	6.3	0	0	220	230		
	AC		AC		AC		AC		

Band Switch on AM position. Dial 1600 KC. No Signal.

All voltage readings are taken from tube pin to chassis.

All measurements are made with no signal, using a 20,000 ohm per volt meter.

AC input voltage must be maintained at 117 volts for accurate readings.

AC voltages shown are at 1000 ohms per volt.

All voltages shown are approximate.

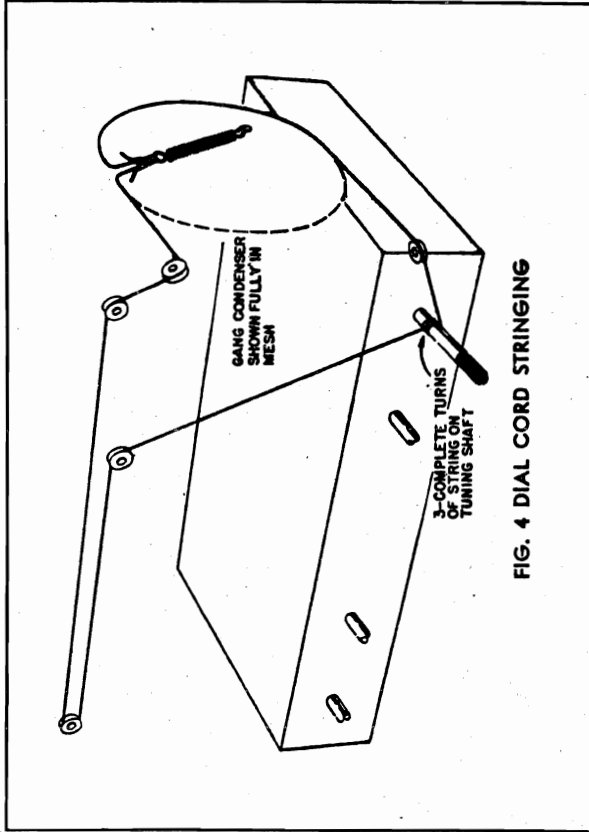
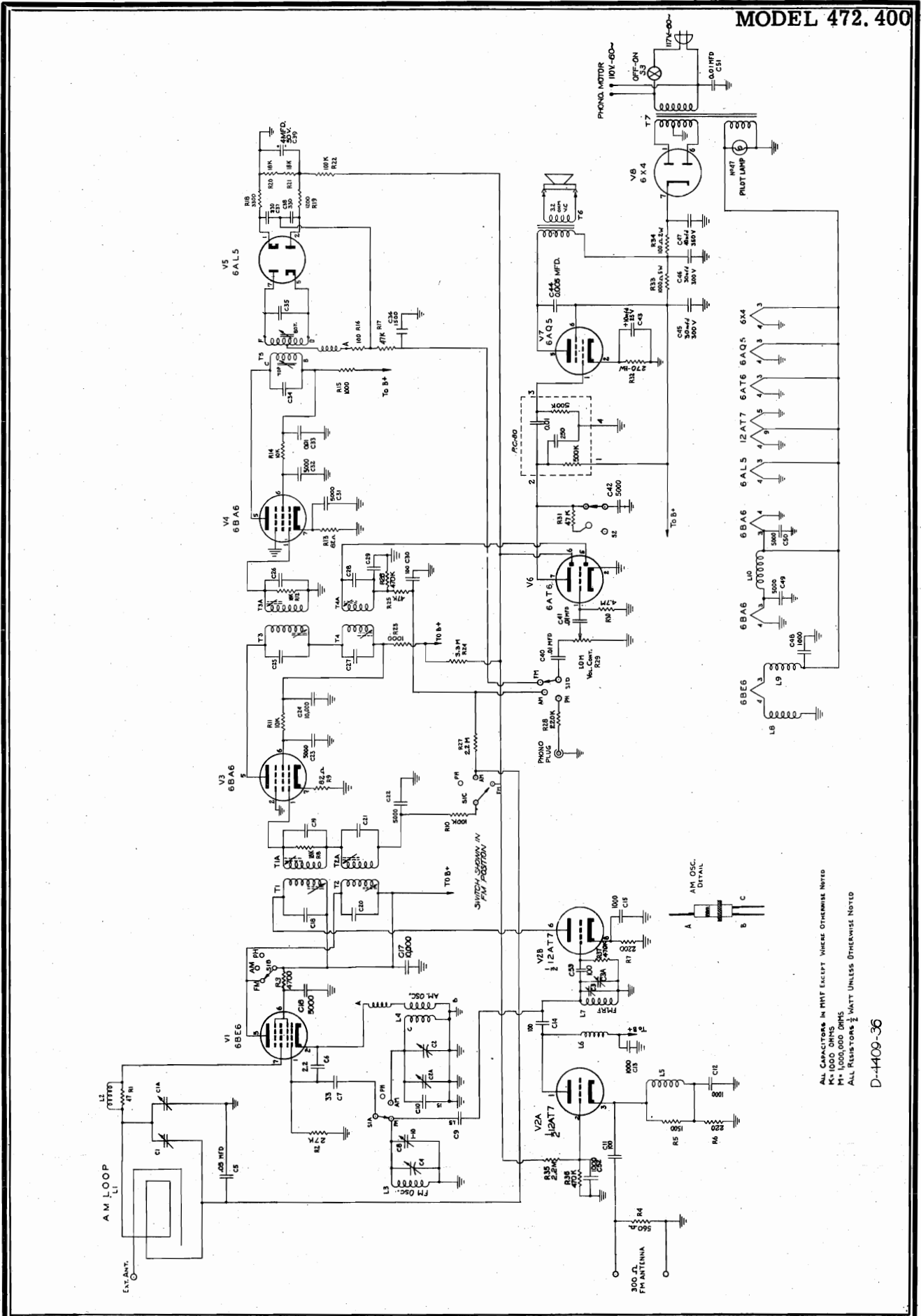

FIG. 4 DIAL CORD STRINGING

HOW TO ORDER REPAIR PARTS

Always give the part No. (No. printed on the part if different from that shown on this list), and the name of the part. When No. is not available, give complete description of part. Be sure to always give the Model No. and Chassis No. The Model No. will be found on a printed label which will be found at the back of the cabinet.



ALL CAPACITORS IN PINT EXCEPT WHERE OTHERWISE NOTED
 K=1000 OHMS
 M=1,000,000 OHMS
 ALL RESISTORS 1/2 WATT UNLESS OTHERWISE NOTED

D-4409-36

CAPACITORS

Reference No.	Part No.	Description
C1, C2, C3, C4	A-1201-6	Tuning Gang
C1A	-----	Trimmer on loop
C2A	-----	Trimmer on gang
C3A	-----	Trimmer on gang
C5	CWZ02503M	.05 mfd-200V paper
C6	CCG05022D	2.2 mmf \pm .5 mmf GP ceramic
C7	CCC05330K	33 mmf \pm 10% NPO ceramic
C8	CVP070ST	1-10 mmf Trimmer
C9	CCG05015D	1.5 mmf \pm .5 mmf GP ceramic
C10	CCC05150K	15 mmf \pm 10% NPO ceramic
C11	CCG05101M	100 mmf \pm 20% GP ceramic
C12	CCG05102Y	1000 mmf GP ceramic
C13	CCG05102Y	1000 mmf GP ceramic
C14	CCG05101M	100 mmf \pm 20% GP ceramic
C15	CCG05102Y	1000 mmf GP ceramic
C16	CDZ05502Y	5000 mmf GMV ceramic
C17	CDZ05103Y	10,000 mmf GMV ceramic
C18	-----	Part of T1
C19	-----	Part of T1
C20	-----	Part of T2
C21	-----	Part of T2
C22	CDZ05502Y	5000 mmf GMV ceramic
C23	CDZ05502Y	5000 mmf GMV ceramic
C24	CDZ05103Y	10,000 mmf GMV ceramic
C25 } C26 } C27 } C28 }	-----	Part of T3
C29	-----	Part of T4
C30	CCG05101M	100 mmf \pm 20% GP ceramic
C31	CDZ05502Y	5000 mmf GMV ceramic
C32	CDZ05502Y	5000 mmf GMV ceramic
C33	CDZ05103Y	10,000 mmf GMV ceramic
C34 } C35 }	-----	Part of T5
C36	CMA05152M	1500 mmf \pm 20% mica or ceramic
C37	CMA05331M	330 mmf \pm 20% mica or ceramic
C38	CMA05331M	330 mmf \pm 20% mica or ceramic
C39	CES0405	4 mfd-50 volt electrolytic
C40	CWZ02103M	.01 mfd-200V paper
C41	CWZ02103M	.01 mfd-200V paper
C42	CWZ06502M	.005 mfd-600V paper
C43	CFQ433C35	10 mfd @25V lytic *
C44	CWZ06502M	.005 mfd-600V paper
C45	CFQ433C35	30 mfd-300V lytic *
C46	CFQ433C35	30 mfd-300V lytic *
C47	CFQ433C35	40 mfd-350V lytic *
C48	CCG05102Y	1000 mmf GP ceramic
C49	CDZ05502Y	5000 mmf GMV ceramic
C50	CDZ05502Y	5000 mmf GMV ceramic
C51	CDZ05103Y	10,000 mmf GMV ceramic
C52	CCG05102Y	1000 mmf GP ceramic
C53	CCG05101M	100 mmf \pm 20% ceramic

*C43, C45, C46, C47 are quadruple section electrolytic.

RESISTORS

R1	-----	Part of L2
R2	RCC273K	27K \pm 10% 1/2W
R3	RCC472M	4700 \pm 20% 1/2W
R4	RCC561M	560 \pm 20% 1/2W

RESISTORS—Continued

Reference No.	Part No.	Description
R5	— — — —	Part of L5
R6	RCC221M	220 ±20% 1/2W
R7	RCC222M	2200 ±20% 1/2W
R8	RCC183K	18K ±10% 1/2W
R9	RCC820K	82 ±10% 1/2W
R10	RCC104M	100K ±20% 1/2W
R11	RCC103M	10K ±20% 1/2W
R12	RCC183K	18K ±10% 1/2W
R13	RCC820K	82 ±10% 1/2W
R14	RCC103M	10K ±20% 1/2W
R15	RCC102M	1000 ±20% 1/2W
R16	RCC101M	100 ±20% 1/2W
R17	RCC473M	47K ±20% 1/2W
R18	RCC332K	3300 ±10% 1/2W
R19	RCC122K	1200 ±10% 1/2W
R20	RCC183K	18K ±10% 1/2W
R21	RCC183K	18K ±10% 1/2W
R22	RCC104M	100K ±20% 1/2W
R23	RCC102M	1000 ±20% 1/2W
R24	RCC335M	3.3M ±20% 1/2W
R25	RCC473M	47K ±20% 1/2W
R26	RCC474M	470K ±20% 1/2W
R27	RCC225M	2.2M ±20% 1/2W
R28	RCC224M	220K ±20% 1/2W
R29	RVC400S	1.0M volume control with switch
R30	RCC475M	4.7M ±20% 1/2W
R31	RCC473M	47K ±20% 1/2W
R32	RCF271M	270 ±20% 1/2W
R33	RWJ102K	1000 ±10% 5W
R34	RCF101M	100 ±20% 1W
R35	RCC225M	2.2M ±20% 1/2W
R36	RCC474M	470K ±20% 1/2W
R37	RCC474M	470K ±20% 1/2W
PC80	A-1376-6F	Centralab PC80 couplate
K=1000 OHMS M=1,000,000 OHMS		

COILS

L1	A-1473-10	Loop Antenna (includes CIA)
L2	A-1499-10	AM grid choke (includes R1)
L3	A-1497-10	FM oscillator coil
L4	A-1498-10	AM oscillator coil
L5	A-1474-10	FM cathode choke (includes R5)
L6	A-1495-10	FM-RF plate choke
L7	A-1496-10	FM-RF coil
L8	A-1494-10	RF filament choke
L9	A-1494-10	RF filament choke
L10	A-1481-10	IF filament choke

TRANSFORMERS

T1	A-1488-10	10.7 MC input IF
T2	A-1490-10	455 KC input IF
T3	A-1489-10	10.7 MC interstage IF
T4	A-1491-10	455 KC output IF
T5	A-1487-10	10.7 MC ratio detector
T6	A-1654-13	Audio output Transformer
T7	A-1655-13	Power Transformer

SWITCHES

S1	A-2002-17	Function switch
S2	A-2003-17	Tone switch
S3	— — — —	Part of R29

MODELS 652. 5975,
652. 5985

INSTALLATION

Your Aircastle radio-phonograph needs no special outside aerial. You may locate it anywhere it is convenient to an outlet. Do not place it near a radiator or heater for the extreme heat may damage the cabinet.

Your radio-phonograph operates on 105-120 volts, 60 cycles, AC only. Do not connect to a supply other than specified or the Guarantee is invalid. If you are not sure of the power supply, your local utility company will supply the information.

HOW TO OPERATE THE RECORD CHANGER

Your Aircastle phonograph is equipped with a Tri-O-Matic record changer and an all-groove, all-speed needle. This means that you can play any size record, any speed record. You may also play any assortment of 10- and 12-inch records of the same speed. Your Tri-O-Matic changer automatically selects the right "set-down" position for 7-10- or 12-inch records.

Loosen the two mounting bolts until the changer floats free on mounting springs.

LOADING: First lift the record support arm off the spindle and swing toward the back.

Place the records (up to ten 12-inch or twelve 10- and 7-inch records) on the spindle and lower to the off-set shelf. Holding the records level, return the record support to spindle. **AUTOMATIC OPERATION:** Now set the **MOTOR SPEED CONTROL** to proper speed for the records to be played (33-1/3, 45 or 78 RPM). As long as you play the same speed record, you can mix 10- and 12-inch records. The 10 and 12-inch index levers will automatically determine the "set-down" posi-

THE RADIO

All the controls for your radio are conveniently located at the front of the cabinet. At the extreme left is the radio-phonograph control knob. When it is set at the first position, the radio will play; the second position turns the phonograph on and automatically starts the turntable. The middle knob is the on-off volume control. At the right is the tone control knob which may be adjusted from treble to bass tones. The station selector is above the radio dial.

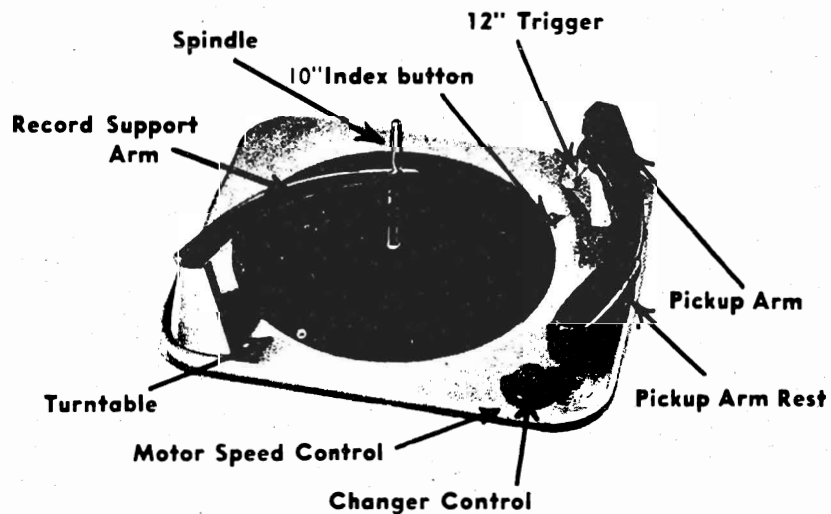

tion. All you have to do is set the motor speed control.

With the records on the spindle, the motor speed control set, turn the changer control knob to REJ (reject) and release. The Tri-O-Matic changer will automatically play all the records on the spindle. After the last record has been played, the changer automatically shuts off, pick-up arm returns to rest, and the turntable stops.

REPEATING AND REJECTING

If you wish to repeat any particular record, place it on the turntable (not the off-set shelf). Do not swing record support over the spindle. Turn the CHANGER CONTROL to REJ and release. The 7- or 10-inch record will automatically repeat until the CHANGER CONTROL is turned to OFF.

Records may be rejected (that is, removing the pick-up arm from the record) at any time by simply turning the CHANGER CONTROL to REJ.

To turn off the phonograph, turn the CHANGER CONTROL to OFF. However, never turn off the phonograph while it is in the changing cycle. Do not attempt to force the pick-up arm back to the arm rest.

MANUAL OPERATION

Before you place any records on the turntable, place the record support arm on the spindle and turn CHANGER CONTROL to REJ. Allow the changer to automatically shut off. Then lift the record support arm and swing to the back, away from the turntable. Place your record (again you can play any size, any speed) on the turntable and set the CHANGER CONTROL to ON. Be careful not to turn past the ON position. With the turntable spinning, place the pick-up arm on the record on the lead-in groove of the record. When you wish to resume automatic operation, set the CHANGER CONTROL to REJ. Then, as outlined above, load records on the spindle.

SCHEMATIC

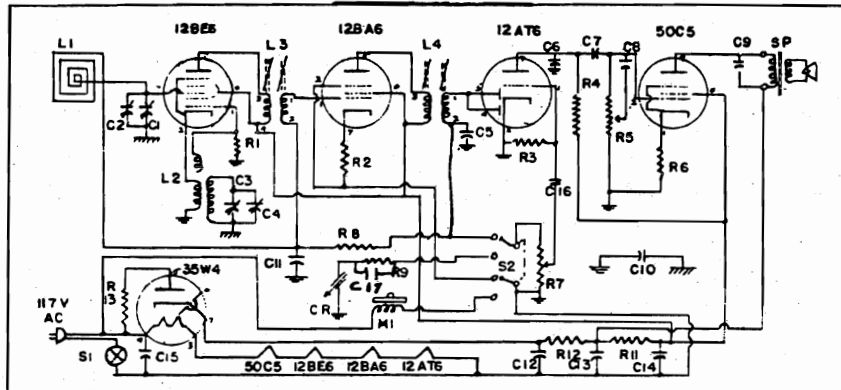

LEGEND

C1 Ant. Variable	R1 22K OHM 1/2 W.	L1 Loop Ant.
C2 Ant. Trimmer	R2 220 OHM 1/2 W.	L2 Osc. Coil
C3 Osc. Variable	R3 10 MEG. OHM 1/2 W.	L3 1st I.F.
C4 Osc. Trimmer	R4 220K OHM 1/2 W.	L4 2nd I.F.
C5 200 MMF. Mica	R5 500K O. Tone Control	
C6 200 MMF. Mica	R6 150 OHM 1/2 W.	
C7 .01 MFD. 400 V.	R7 1 Meg. Vol. Con. W/SW	S1 AC Switch on V.C.
C8 .002 MFD. 400 V.	R8 2.2 Meg. 1/2 W.	S2 Radio-Phono Switch
C9 .01 MFD. 600 V.	R9 1.0 Meg. 1/2 W.	CR Pick Up
C10 .1 MFD. 400 V.	R11 2200 OHM 1 W.	M1 Phono Motor
C11 .05MFD 400V.	R12 330 OHM 1 W.	SP 5in. Speaker
C12 40MFD 150V. Electrolytic	R13 18 OHM 1/2 W.	
C13 40 MFD. 150 V.		
C14 20 MFD. 150 V.		
C15 .01 MFD. 400 V.		
C16 .01 MFD. 400 V.		
C17 200 MMFD.		

TUBE LAYOUT CHART

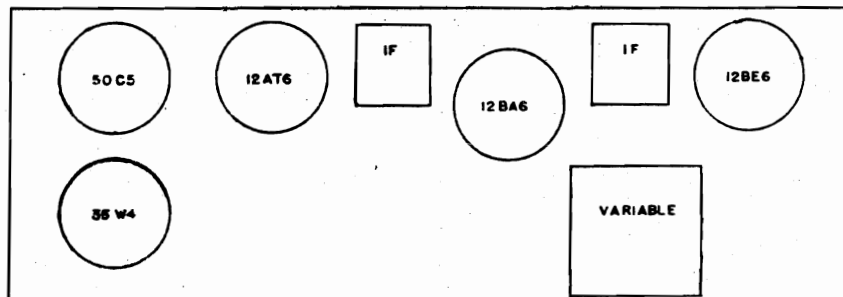

MODELS 652. 5975,
652. 5985

ALIGNMENT PROCEDURE

Receiver Dial Setting	Signal Generator Frequency	Dummy Antenna	Signal Generator Connections	Output Indicator	Trimmer Adjustment	Trimmer Function	Remarks
Minimum capacity	455 KC 400 cycle AM	.1MFD	High side-grid converter tube 12BE6 Low side-chassis	Output Meter across voice coil	L3 & L4	I.F.	Adjust for maximum output
"	1600 KC 400 cycle AM	"	"	"	C-4 OSC	Oscillator	"
1400 KC	1400 KC 400 cycle AM	.00025 MFD	High side-one ant. terminal Low side-Other ant. terminal	"	C-2 Ant. Loop	Antenna	"

HOW TO ORDER PARTS

The following information is needed to properly handle your repair part order.
ALWAYS SPECIFY on your order blank -

Item for which Part is Ordered	Model No.	Serial No. (When Given)	Part No.	Description Of Part	Quantity Wanted	Price of Each Part	Total Price	Shipping Weight
RADIO- PHONOGRAPH								

**PARTS LIST
FOR MODELS 652. 5975 and 652. 5985**

ILLUSTRATION NUMBER	PART NUMBER	DESCRIPTION OF PART	PRICE EACH
C1-C2-C3-C4	CV-20	Var. Cond. Two gang Tuning	\$ 1.70
C5-C6-C17	CM-221	Mica Cond. 200 mmfd	.20
C7-C15-C16	CP-103-4	Tubular Cond. .01 mfd - 400V	.20
C8	CP-202-4	Tubular Cond. .002 mfd - 400V	.20
C9	CP-103-6	Tubular Cond. .01 mfd - 600V	.20
C10	CP-104-4	Tubular Cond. .1 mfd - 400V	.20
C11	CP-503-4	Tubular Cond. .05 mfd - 400V	.20
C12-C13-C14	CE-1000	Elect. Cond. 40 x 40 x 20 mfd/150V	1.20
R1	RC-223-1	Carbon Res. 22K ohm 1/2W 20%	.20
R2	RC-221-1	Carbon Res. 220 ohm 1/2W 20%	.20
R3	RC-106-1	Carbon Res. 10 meg ohm 1/2W 20%	.20
R4	RC-224-1	Carbon Res. 220K ohm 1/2W 20%	.20
R5	VC-19	Tone Cont 500K ohm	.80
R6	RC-151-1	Carbon Res. 150 ohm 1/2W 20%	.20
R7	VC-18	Vol. Cont w/S 1 meg ohm	.80
R8	RC-225-1	Carbon Res. 2.2 meg ohm 1/2W 20%	.20
R9	RC-105-1	Carbon Res. 1.0 meg ohm 1/2W 20%	.20
R11	RC-222-4	Carbon Res. 2200 ohm 1W 20%	.20
R12	RC-331-4	Carbon Res. 330 ohm 1W 20%	.20
R13	RC-180-1	Carbon Res. 18 ohm 1/2W 20%	.20
L1	LP-510	Loop Ant.	1.00
L2	LC-10	Osc. Coil	1.00
L3	IFT 50	1st I.F.	1.60
L4	IFT 50	2nd I.F.	1.60
S2	SW12	Switch, Radio & Phono	.60
CR	Astatic LT5-AG	Crystal	6.00
B55		Fidelitone Needle or equivalent	1.00
M1	VM-950-26	VM Changer	50.00
SP	SP-100	5" Speaker w/output XFMR	5.00
		Tube 12BE6	1.80
		Tube 12BA6	1.80
		Tube 12AT6	1.50
		Tube 50C5	2.00
		Tube 35W4	1.25

ALL ORDERS ARE SUBJECT TO PRICES AT TIME OF SHIPMENT

ALIGNMENT PROCEDURE

MODELS 9160-A, -B, -C, -D, -E

- During the alignment of this receiver, the Tuning and Pointer knob will have to be set to a specific frequency. Since the dial scale is an integral part of the cabinet, the receiver chassis must be in the cabinet for correct positioning of the gang condenser and pointer. Before removing chassis from cabinet it will first be necessary to take off Volume Control knob, to pry off the two retaining clips at top of cabinet back and to remove the two chassis mounting screws which are accessible through slot openings at each side of cabinet back. (NOTE: Do not disturb the two externally mounted screws at bottom of cabinet back; these screws serve to mount loop and back to chassis frame.) Then turn the Tuning and Pointer knob to the desired position for alignment and, taking care not to change this setting, pull Tuning and Pointer knob from gang condenser shaft. Now chassis can be withdrawn from cabinet without disturbing position of condenser.
- Couple the signal generator to the receiver by connecting its output to several turns of wire formed in a circular shape so that it may be placed adjacent and parallel to the receiver loop antenna.
- Connect an output meter across the speaker voice coil or from the plate of the 50C5 tube to chassis through a 0.1 Mfd. condenser.
- Set volume control at maximum volume position and use a weak signal from the signal generator.

DUMMY ANT. IN SERIES WITH SIGNAL GENERATOR	SIGNAL GENERATOR CONNECTION	SIGNAL GENERATOR FREQUENCY	RECEIVER DIAL SETTING	TRIMMER AND SLUG NUMBER	TRIMMER AND SLUG DESCRIPTION	TYPE OF ADJUSTMENT
NONE	Connect directly to coupling turn as described in step 2 above.	455 KC 400 cycle Modulation	Any point where it does not affect the signal.	1-2 3-4	2nd I.F. 1st I.F.	Adjust for maximum output. Then repeat adjustment.
NONE	Connect directly to coupling turn as described in step 2 above.	1500 KC 400 cycle Modulation	1500 KC	5	Broadcast Oscillator	Adjust for maximum output.
NONE	Connect directly to coupling turn as described in step 2 above.	1500 KC 400 cycle Modulation	Tune to 1500 KC generator signal	6	Broadcast Antenna	Adjust for maximum output.

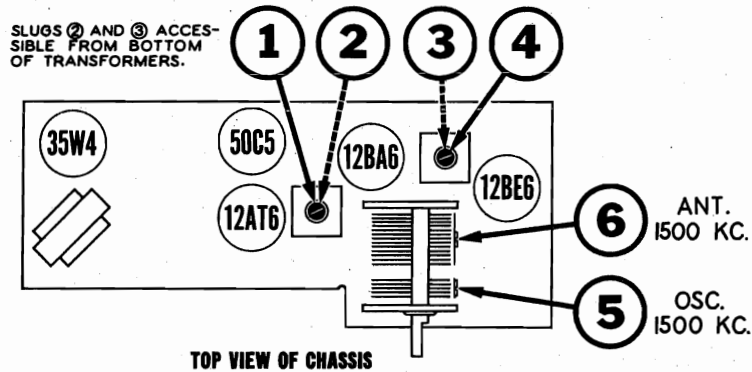

SOCKET VOLTAGES

- All measurements made with a voltmeter having a sensitivity of 20,000 ohms per volt except where indicated by (*). The (*) symbol designates a vacuum tube voltmeter measurement.
- Dial tuned to maximum counter-clockwise position.

BOTTOM VIEW OF CHASSIS

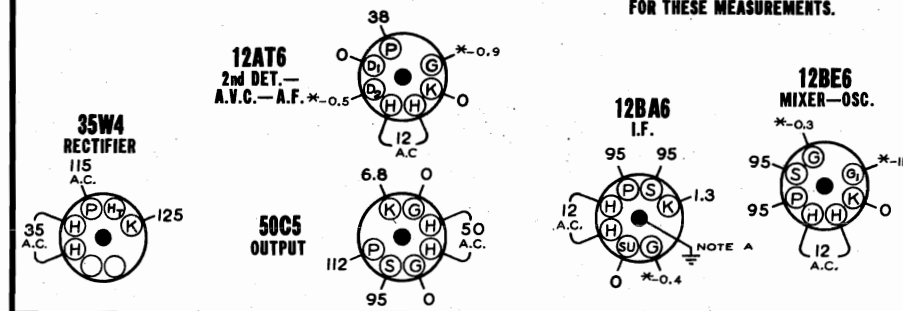

NOTE A: Grounding of center stud on tube socket is necessary to reduce capacity coupling between other pins. Oscillation may result if this ground is omitted.

MODELS 9160-A, 9160-B,
9160-C, 9160-D, 9160-E

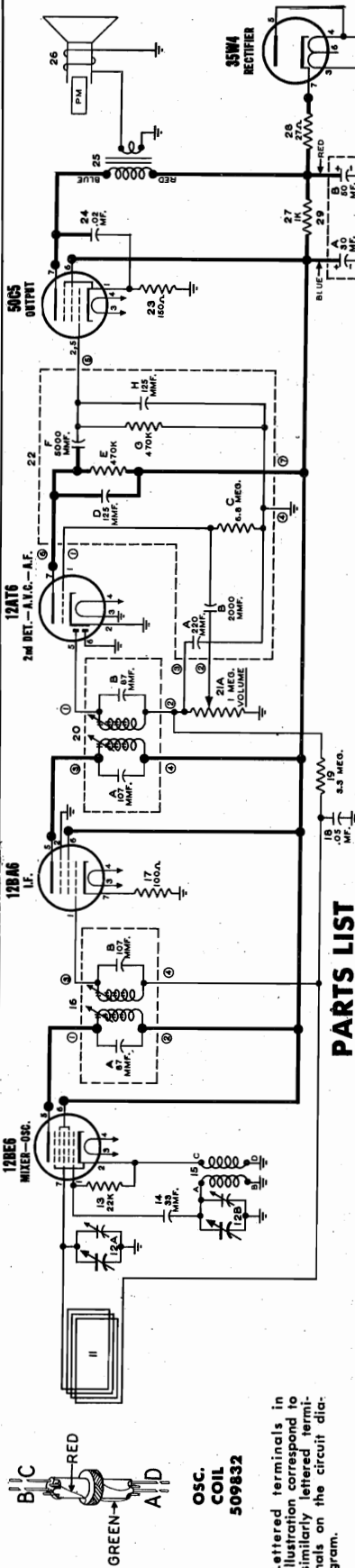

Lettered terminals in illustration correspond to similarly lettered terminals on the circuit diagram.

I.F. 455 KC.



PARTS LIST

DIA. GRAM. NO.	PART NO.	DESCRIPTION	LIST PRICE
12-A, B	509827	Condenser—variable gang	\$ 3.00
14	513028	Condenser—ceramic 33 Mmfd. 500 volt	.25
16-A	509433	Condenser—ceramic 87 Mmfd. (part of 1st I.F. Transformer)	1.75
16-B	509433	Condenser—ceramic 107 Mmfd. (part of 1st I.F. Transformer)	1.75
18	512028	Condenser—.05 Mfd. 400 volt	.25
20-A	509433	Condenser—ceramic 107 Mmfd. (part of 2nd I.F. Transformer)	1.75
20-B	509433	Condenser—ceramic 87 Mmfd. (part of 2nd I.F. Transformer)	1.75
22-A	509836	Condenser—ceramic 220 Mmfd. 500 volt (part of audio coupling unit)	1.00
22-B	509836	Condenser—ceramic 2000 Mmfd. 500 volt (part of audio coupling unit)	1.00
22-D	509836	Condenser—ceramic 125 Mmfd. 500 volt (part of audio coupling unit)	1.00
22-F	509836	Condenser—ceramic 5000 Mmfd. 500 volt (part of audio coupling unit)	1.00
22-H	509836	Condenser—ceramic 125 Mmfd. 500 volt (part of audio coupling unit)	1.00
24	512016	Condenser—.02 Mfd. 400 volt	.25
29-A, B	509837	Condenser—electrolytic A—30 Mfd. 150 volt B—50 Mfd. 150 volt	2.00
30	512028	Condenser—.05 Mfd. 400 volt	.25
13	510161	Resistor—carbon 22,000 Ohms 1/2 watt	.12
17	510119	Resistor—carbon 100 Ohms 1/2 watt	.12
19	510194	Resistor—carbon 3.3 Meg. 1/2 watt	.12
21-A, B	509830	Volume Control—1 Meg. (with OFF-ON switch)	1.25
22-C	509836	Resistor—carbon 6.8 Meg. 1/5 watt (part of audio coupling unit)	1.00
22-E	509836	Resistor—carbon 470,000 Ohms 1/5 watt (part of audio coupling unit)	1.00
22-G	509836	Resistor—carbon 470,000 Ohms 1/5 watt (part of audio coupling unit)	1.00
23	510122	Resistor—carbon 150 Ohms 1/2 watt	.12
28	510108	Resistor—carbon 27 Ohms ± 10% 1/2 watt	.12
27	510237	Resistor—carbon 1000 Ohms 1 watt	.16
COILS AND TRANSFORMERS			
11	509833	Loop antenna and cabinet back	1.25
CONDENSERS			
15	509832	Coil—oscillator	\$ 1.70
16	509433	Transformer—1st I.F. (includes condensers 16-A and 16-B)	1.75
20	509433	Transformer—2nd I.F. (includes condensers 20-A and 20-B)	1.75
25	509826	Transformer—output	2.00
OTHER ELECTRICAL PARTS			
Audio Coupling Unit			
22-A to H	509836	A—Condenser—ceramic 220 Mmfd. 500 v. B—Condenser—ceramic 2000 Mmfd. 500 v. C—Resistor—carbon 6.8 Meg. 1/5 w. D—Condenser—ceramic 125 Mmfd. 500 v. E—Resistor—carbon 470,000 Ohms 1/5 w. F—Condenser—ceramic 5000 Mmfd. 500 v. G—Resistor—carbon 470,000 Ohms 1/5 w. H—Condenser—ceramic 125 Mmfd. 500 v.	1.00
26	509828	Speaker—P.M. dynamic (4")	5.00
MISCELLANEOUS PARTS			
509833		Back for cabinet (includes loop antenna)	1.25
520215		Background for pointer knob used on Models 9160-D and 9160-E	.10
509840-A		Cabinet for Model 9160-A (Mahogany)	4.00
509840-B		Cabinet for Model 9160-B (Yellow)	4.00
509840-C		Cabinet for Model 9160-C (Blue)	4.00
520342		Cabinet for Model 9160-D (Rust)	4.25
505101		Cabinet for Model 9160-E (Tan)	4.25
500497		Clip for mounting 1st and 2nd I.F. Transformers	.05
509874		Clip—retains speaker	.03
509839-A		Knob—Pointer for Models 9160-A and 9160-D (Tan)	.40
509839-B		Knob—Pointer for Model 9160-B (Green)	.40
509839-C		Knob—Pointer for Model 9160-C (Blue)	.40
509839-E		Knob—Pointer for Models 9160-A and 9160-D (Tan)	.12
509841-A		Knob—Volume for Model 9160-B (Green)	.12
509841-B		Knob—Volume for Model 9160-C (Blue)	.12
509841-E		Knob—Volume for Model 9160-E (Rust)	.12
509829		Rubber spacer for mounting speaker	.02
170820		Screw—#8-32 x 1/2"; retains chassis	.02
507595		Socket—miniature	.20
509876		Stud for mounting speaker	.01

ALL PRICES ON THIS PARTS LIST ARE SUBJECT TO CHANGE WITHOUT NOTICE

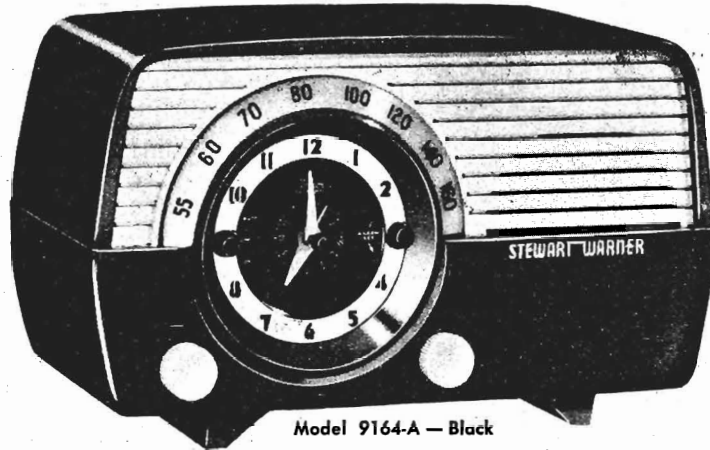

Model 9164-A — Black

Model 9164-B—Grey and Yellow

SPECIFICATIONS

FREQUENCY RANGE:

540 Kc. to 1600 Kc.

TUNING METHOD:

2 section ganged condenser; solid mounting.

TUNING INDICATOR:

"GLOW LITE" illuminates tuned frequency thru translucent dial.

I.F. FREQUENCY:

455 Kc.

POWER SUPPLY:

117 volts A.C.

SPEAKER:

4 inch PM Dynamic
Voice coil impedance—3.2 ohms

POWER OUTPUT:

Undistorted—.7 watt
Maximum—1.1 watt

ANTENNA:

High impedance loop

WEIGHT: (Packed)

7 lbs.

DIMENSIONS:

Length—11 $\frac{3}{8}$ "
Height—6 $\frac{1}{4}$ "
Depth—5 $\frac{3}{8}$ "

CLOCK DIAL:

Easy to read Black and Gold numerals and gold hands.

CLOCK SET:

Conveniently accessible at front of clock.

ALARM:

Turns radio on at a pre-set time.

CLOCK OPERATION

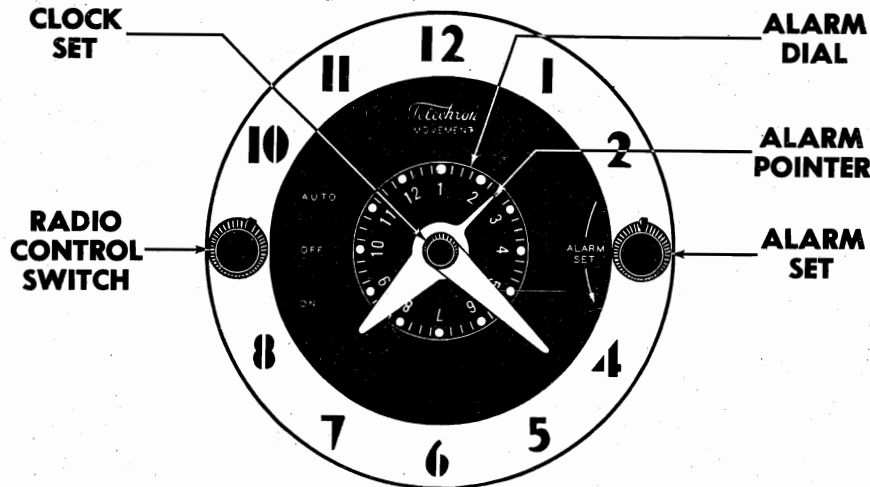

The clock in this combination receiver is self-starting and therefore when the receiver plug is inserted into the wall outlet the clock will automatically start. Should there be a temporary stoppage of current, due to a power failure or other causes, the clock will automatically be turned on again after power has been restored. Resetting of the clock hands will then be required to make-up for the time the power was off.

SETTING THE CLOCK HANDS: To set the clock hands to the correct time merely use the Clock Set knob and rotate hands until they indicate the correct time.

SETTING CLOCK AND RECEIVER FOR AUTOMATIC OPERATION: Tune the radio to the desired station and set the volume to the proper level. Turn Radio Control Switch to the "AUTO" position.

To set the Starting Time, rotate Alarm Set knob only in the direction indicated by the "ALARM" arrow until the Alarm Pointer on the hour hand indicates the desired time on the Alarm Dial. Radio will automatically be turned on at this pre-set time and will continue to play until receiver is turned off manually. Clock can not be again set for automatic operation until Radio Control Switch has been turned manually to the "OFF" position.

Part 520334
Jan. 25, 1952

MODELS 9164-A,
9164-B

REMOVING AND REPLACING CLOCK KNOBS AND CRYSTAL

KNOBS: The Radio Control Switch knob, or the Alarm Set knob may be taken off by prying them forward. The Clock Set knob is screwed on and must be removed by rotating it in a counterclockwise direction while at the same time holding the shaft steady with a fine pair of long nose pliers—**WARNING: Place a piece of paper between pliers and the dial crystal to avoid damage to this part.**

CRYSTAL: In order to service this part, it will be necessary to remove receiver chassis from cabinet, and to withdraw clock unit from chassis.

To remove receiver chassis from cabinet first take off the Volume and Tuning knobs. Next pry off the two retaining clips at top of cabinet back and remove the two chassis mounting screws which are accessible through slot openings at each side of cabinet back. (NOTE: Do not disturb the two externally mounted screws at bottom of cabinet back;

these screws serve to mount loop and back to chassis.) Chassis can now be withdrawn from cabinet.

To remove the clock, first slip the "Glow Lite" from its bracket. Next, remove the fibre shield around top of clock by prying off the two retaining clips located on each end of shield. Unsolder all leads coming from radio chassis to the clock. Now take off the three mounting screws that retain clock mounting bracket and entire unit can be withdrawn from receiver chassis. Remove the clock knobs as indicated in previous section.

Next, bend out the four retaining ears that hold bezel in position and remove it from clock. The bezel background and crystal can now be taken off.

PARTS REPLACEMENT

Should it be desired to replace any other parts than those listed in the receiver parts list, they may be obtained by writing to:

Telechron Dept.
General Electric Co.
Ashland, Mass.

Please specify that unit for which parts are wanted is a C40Bg10 Switch Timer.

"GLOW LITE" DRIVE CORD ARRANGEMENT

Stringing of drive cord can be greatly facilitated if removal of the clock is undertaken. To string drive cord, turn the gang condenser drum to maximum counterclockwise position and use the following parts:

- 505161 Tension spring
- 117057 Cord (2½ ft.)
- 119087 Ring
- 114955 Clip

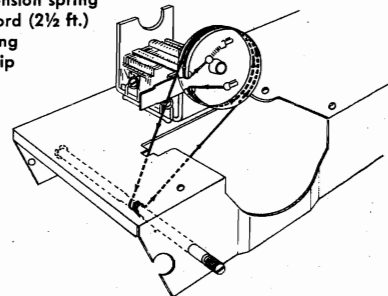

ALIGNMENT PROCEDURE

1. During the alignment of this receiver, the "GLOW LITE" tuning indicator will have to be set to a specific frequency. Since the dial scale is an integral part of the cabinet, the receiver chassis must be in the cabinet for correct positioning of the gang condenser and pointer. Before removing chassis from cabinet it will first be necessary to take off Volume Control knob, to pry off the two retaining clips at top of cabinet back and to remove the two chassis mounting screws which are accessible through slot openings at each side of cabinet back. (NOTE: Do not disturb the two externally mounted screws at bottom of cabinet back; these screws serve to mount loop and back to chassis frame.) Then turn the Tuning knob to the desired position for

alignment and, taking care not to change this setting, pull Tuning knob from shaft. Now chassis can be withdrawn from cabinet without disturbing position of condenser.

2. Couple the signal generator to the receiver by connecting its output to several turns of wire formed in a circular shape so that it may be placed adjacent and parallel to the receiver loop antenna.
3. Connect an output meter across the speaker voice coil or from the plate of the 50C5 tube to B—lug through a 0.1 Mfd. condenser.
4. Set volume control at maximum volume position and use a weak signal from the signal generator.

DUMMY ANT. IN SERIES WITH SIGNAL GENERATOR	SIGNAL GENERATOR CONNECTION	SIGNAL GENERATOR FREQUENCY	RECEIVER DIAL SETTING	TRIMMER AND SLUG NUMBER	TRIMMER AND SLUG DESCRIPTION	TYPE OF ADJUSTMENT
NONE	Connect directly to coupling turn as described in step 2 above.	455 KC 400 cycle Modulation	Any point where it does not affect the signal.	1-2 3-4	2nd I.F. 1st I.F.	Adjust for maximum output. Then repeat adjustment.
NONE	Connect directly to coupling turn as described in step 2 above.	1500 KC 400 cycle Modulation	1500 KC	5	Broadcast Oscillator	Adjust for maximum output.
NONE	Connect directly to coupling turn as described in step 2 above.	1500 KC 400 cycle Modulation	Tune to 1500 KC generator signal	6	Broadcast Antenna	Adjust for maximum output.

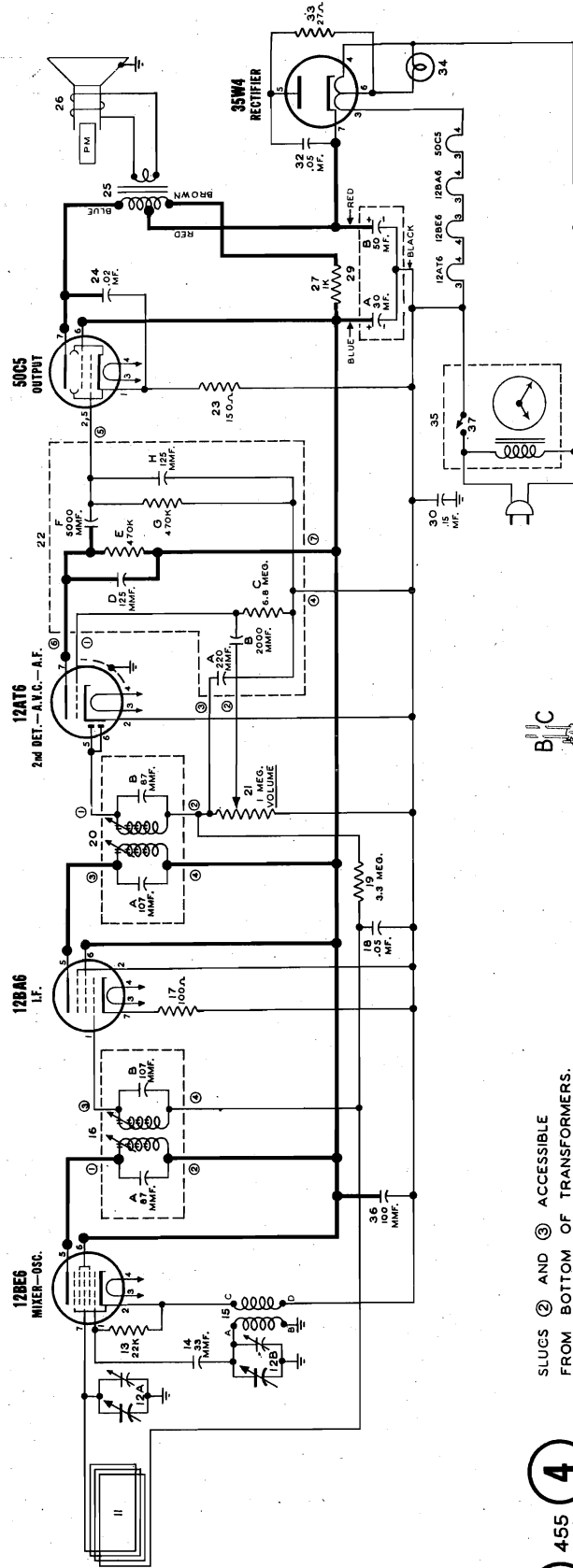

PRODUCTION CHANGES

The following change was incorporated to meet an underwriter's request and receivers incorporating this change are stamped "SERIES A" on the cabinet back.
 1. Resistor 31 (330 Ohms) was removed. It formerly was wired in parallel with "GLOW LITE" 34.
 The following change was incorporated to eliminate hum modulation and receivers incorporating this change are stamped "SERIES B" on the cabinet back.
 1. A.V.C. condenser 18 (.05 Mfd) was disconnected from chassis ground and reconnected to B-.

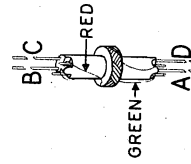

OSC. COIL
509832

Lettered terminals in illustration correspond to similarly lettered terminals on the circuit diagram.

SLUGS ② AND ③ ACCESSIBLE FROM BOTTOM OF TRANSFORMERS.

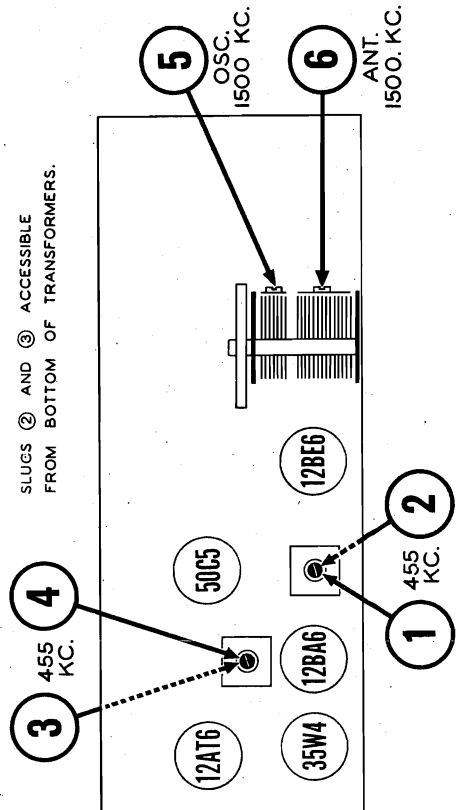

TRIMMER LOCATIONS

I.F. 455 KC.

MODELS 9164-A,
9164-B

SOCKET VOLTAGES

1. All measurements made with a voltmeter having a sensitivity of 20,000 ohms per volt except where indicated by (*). The (*) symbol designates a vacuum tube voltmeter measurement.
2. Dial tuned to maximum counter-clockwise position.

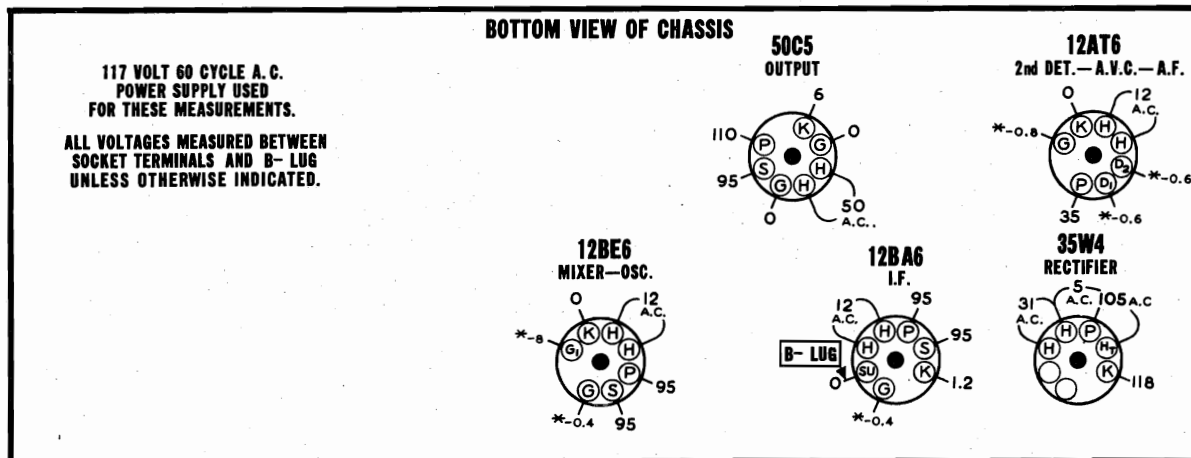

REAR OF CHASSIS

PARTS LIST

DIA-GRAM NO.	PART NO.	DESCRIPTION	LIST PRICE
CONDENSERS			
12-A, B	520266	Condenser—variable gang (includes drum and "GLOW LITE" mtg. bracket)	\$ 3.00
14	513028	Condenser—ceramic 33 Mmfd. 500 volt	.25
16-A	509433	Condenser—ceramic 87 Mmfd. (part of 1st I.F. Transformer)	1.75
16-B	509433	Condenser—ceramic 107 Mmfd. (part of 1st I.F. Transformer)	1.75
18	512029	Condenser—.05 Mfd. 400 volt	.35
20-A	509433	Condenser—ceramic 107 Mmfd. (part of 2nd I.F. Transformer)	1.75
20-B	509433	Condenser—ceramic 87 Mmfd. (part of 2nd I.F. Transformer)	1.75
22-A	509836	Condenser—ceramic 220 Mmfd. 500 volt (part of audio coupling unit)	1.00
22-B	509836	Condenser—ceramic 2000 Mmfd. 500 volt (part of audio coupling unit)	1.00
22-D	509836	Condenser—ceramic 125 Mmfd. 500 volt (part of audio coupling unit)	1.00
22-F	509836	Condenser—ceramic 5000 Mmfd. 500 volt (part of audio coupling unit)	1.00
22-H	509836	Condenser—ceramic 125 Mmfd. 500 volt (part of audio coupling unit)	1.00
24	512017	Condenser—.02 Mfd. 400 volt	.28
29-A, B	520261	Condenser—electrolytic A—30 Mfd. 150 volt B—50 Mfd. 150 volt	1.75
30	512040	Condenser—.15 Mfd. 400 volt	.35
32	512029	Condenser—.05 Mfd. 400 volt	.35
36	512503	Condenser—mica 100 Mfd. 400 volt	.25
RESISTORS			
13	510161	Resistor—carbon 22,000 Ohms 1/2 watt	.12
17	510119	Resistor—carbon 100 Ohms 1/2 watt	.12
19	510194	Resistor—carbon 3.3 Meg. 1/2 watt	.12
21	520263	Volume Control—1 Meg.	.85
22-C	509836	Resistor—carbon 6.8 Meg. 1/5 watt (part of audio coupling unit)	1.00
22-E	509836	Resistor—carbon 470,000 Ohms 1/5 watt (part of audio coupling unit)	1.00
22-G	509836	Resistor—carbon 470,000 Ohms 1/5 watt (part of audio coupling unit)	1.00
23	510122	Resistor—carbon 150 Ohms 1/2 watt	.12
27	510237	Resistor—carbon 1000 Ohms 1 watt	.16
31	510128	Resistor—carbon 330 Ohms 1/2 watt	.12
33	510108	Resistor—carbon 27 Ohms ± 10% 1/2 watt	\$.12
COILS AND TRANSFORMERS			
11	520374	Loop antenna and cabinet back	1.50
15	509832	Coil—oscillator	1.70
16	509433	Transformer—1st I.F. (includes condensers 16-A and 16-B)	1.75
20	509433	Transformer—2nd I.F. (includes condensers 20-A and 20-B)	1.75
25	520432	Transformer—output	2.25

DIA-GRAM NO.	PART NO.	DESCRIPTION	LIST PRICE
OTHER ELECTRICAL PARTS			
22-A to H	509836	Audio Coupling Unit A—Condenser—ceramic 220 Mmfd. 500 v. B—Condenser—ceramic 2000 Mmfd. 500 v. C—Resistor—carbon 6.8 Meg. 1/5 w. D—Condenser—ceramic 125 Mmfd. 500 v. E—Resistor—carbon 470,000 Ohms 1/5 w. F—Condenser—ceramic 5000 Mmfd. 500 v. G—Resistor—carbon 470,000 Ohms 1/5 w. H—Condenser—ceramic 125 Mmfd. 500 v.	1.00
26	520264	Speaker—P.M. dynamic (4")	5.25
34	118921	"GLOW LITE" Lamp (Mazda #47) 6-8 v. 150 Ma.	.15
35	520333	A-Clock, complete	12.00
37	520539	Switch, Radio Control (mounted on clock)	1.20
MISCELLANEOUS PARTS			
	520374	Back for cabinet (includes loop antenna)	1.50
	507593	Base for tube shield	.20
	505165	"C" washer for pointer shaft	.02
	520250-C	Cabinet for Model 9164-A (Black) (less dial scale)	6.25
	520250-D	Cabinet for Model 9164-B (Grey and Yellow) (less dial scale)	6.25
	520372	Clip for mounting clock shield	.05
	508257	Clip for mounting electrolytic condenser	.10
	505101	Clip for mounting I.F. transformers	.05
	500497	Clip—retainer for cabinet back	.02
	114955	Clip—retainer on end of dial cord	.01
	520277	Clip, retains dial scale	.05
	509874	Clip, retains speaker	.03
	117057	Cord—dial drive (2 1/2 ft. required)....per ft.	.05
	520564	Crystal for clock face	1.00
	520251	Dial scale	.70
	520539	Knob; Alarm Set or Radio Control Switch	.10
	520538	Knob; Time Set	.30
	520252-B	Knob; volume or tuning for Model 9164-A (Black)	.15
	520252-C	Knob; volume or tuning for Model 9164-B (Yellow)	.15
	520423	Pointer and shield for "GLOW LITE"	.35
	119087	Ring for dial cord	.01
	509829	Rubber spacer for mounting speaker	.02
	170988	Screw—#8-18 x 1/2" plastic thread cutting; retains chassis	.02
	520265	Shaft—tuning	.40
	520257	Shield for clock	.10
	507594	Shield, tube	.15
	520272	Socket for "GLOW LITE"	.50
	507595	Socket—miniature (7 pin)	.20
	505161	Spring—tension dial cord tension	.08
	509876	Stud for mounting speaker	.01
	111456	Washer—spring washer for tuning shaft	.01

ALL PRICES ON THIS PARTS LIST ARE
SUBJECT TO CHANGE WITHOUT NOTICE

MODELS 9162-A,
9162-B

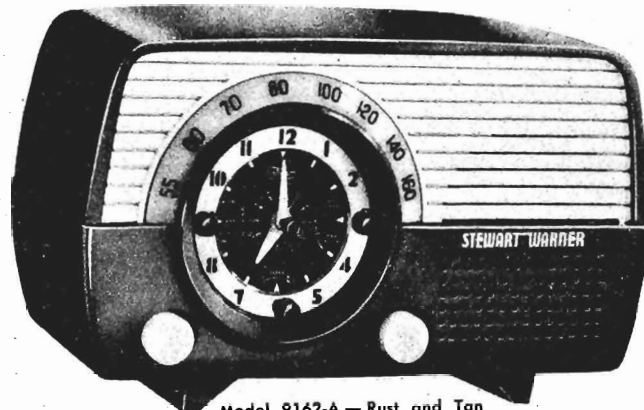

Model 9162-A — Rust and Tan
Model 9162-B — Yellow and Black

SPECIFICATIONS

FREQUENCY RANGE:

540 Kc. to 1600 Kc.

TUNING METHOD:

2 section ganged condenser; solid mounting.

TUNING INDICATOR:

"GLOW LITE" illuminates tuned frequency thru translucent dial.

I.F. FREQUENCY:

455 Kc.

POWER SUPPLY:

117 volts A.C.

SPEAKER:

4 inch PM Dynamic
Voice coil impedance—3.2 ohms

CLOCK SET:

Conveniently accessible at front of clock.

ALARM:

Turns radio on at a pre-set time. "Buzzer Alarm" can be set to sound ten minutes after radio has been "turned on" automatically.

SLEEP SWITCH:

Turns radio off automatically up to one hour after being set.

UTILITY SOCKET:

Accommodates a 117 volt A.C. type appliance whose rating does not exceed 1100 watts.

POWER OUTPUT:

Undistorted—7 watt
Maximum—1.1 watt

ANTENNA:

High impedance loop

WEIGHT: (Packed)

7 lbs.

DIMENSIONS:

Length—11 $\frac{1}{2}$ "
Height—6 $\frac{3}{4}$ "
Depth—5 $\frac{1}{4}$ "

CLOCK DIAL:

Easy to read Black and Gold numerals with luminescent hour markers and hands.

CLOCK OPERATION

The clock in this combination receiver is self-starting and therefore when the receiver plug is inserted into the wall outlet the clock will automatically start. Should there be a temporary stoppage of current, due to a power failure or other causes, the clock will automatically be turned on again after power has been restored. Resetting of the clock hands will then be required to make-up for the time the power was off.

SETTING THE CLOCK HANDS: To set the clock hands to the correct time merely use the Clock Set knob and rotate hands until they indicate the correct time.

SETTING CLOCK AND RECEIVER FOR AUTOMATIC OPERATION: Tune the radio to the desired station and set the volume to the proper level. Turn Radio Control Switch to the "AUTO" position.

To set the Starting Time, pull the Alarm Set knob forward. Then rotate this knob **only** in the direction indicated by the "ALARM" arrow until the Alarm Pointer on the hour hand indicates the desired time on the Alarm Dial. Radio will automatically be turned on at this pre-set time and will continue to play until receiver is turned off **manually**. Clock can not be again set for automatic operation until Radio Control Switch has been turned manually to the "OFF" position.

If you wish to hear the "buzzer alarm," leave the Alarm Set knob in the "out" position and the buzzer will sound approximately 10 minutes

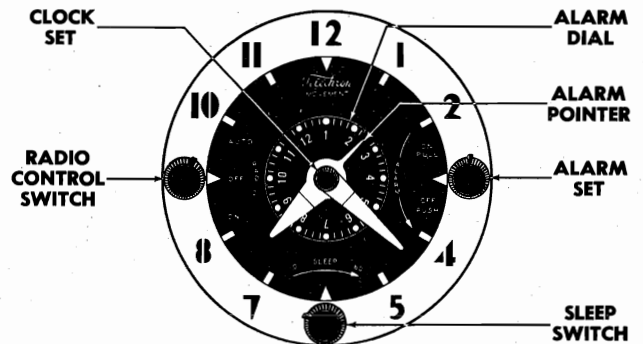

after radio has been turned on. To shut buzzer off, merely push in the Alarm Set knob.

If you do not wish the "buzzer alarm" to sound, push Alarm Set knob in after completing the setting of the Starting Time.

**MODELS 9162-A,
9162-B**

USING "BUZZER ALARM" INDEPENDENTLY OF THE RADIO OPERATION: If you wish to use the clock as an alarm only, independent of the radio, merely set alarm as described in paragraph entitled "To set the Starting Time." Set the Alarm Dial approximately 10 minutes ahead of desired Alarm Time. To shut the buzzer off, push in the Alarm Set knob.

SETTING CLOCK AND RECEIVER FOR AUTOMATIC SHUT-OFF: If radio has been previously turned on automatically, it will first be necessary to momentarily set Radio Control Switch to the "OFF" position before setting it to either of the following positions. Place the Radio Control Switch in either the "OFF" or "AUTO" position. **THE TWO PRECEDING PROCEDURES ARE VERY IMPORTANT!** Setting the control to the "AUTO" position will allow the receiver to subsequently be turned on automatically at a pre-set time.

Now, turn the Sleep Switch in the direction of the "SLEEP" arrow. Rotating this knob all the way clockwise to the "60" position will allow the radio to operate for approximately one hour from the time the Sleep Switch has been set.

Setting this switch to any intermediate point will allow the receiver to operate for a proportional part of the hour.

CONNECTING THE APPLIANCE: Insert the power plug of the appliance into the utility socket provided at rear of the receiver. **This appliance must have a wattage rating that does not exceed 1100 watts.** If this wattage is exceeded, damage to either the timing mechanism or the radio could occur.

AUTOMATIC STARTING OF THE APPLIANCE: To start the appliance automatically, turn the "ON-OFF" Switch of the appliance to the "ON" position and set the clock as described in paragraph entitled "To set the Starting Time." The radio and utility socket are energized simultaneously and therefore the radio can not be turned on while the instrument is pre-set for automatic operation of an appliance. But, once the appliance is on, the radio can be used in the normal manner.

If you do not wish to hear the radio when the appliance is automatically turned on, turn the Volume Control fully counter-clockwise.

When you have finished using the appliance and wish to use the radio independently of it, either turn the appliance's "ON-OFF" Switch to the "OFF" position or remove the appliance plug from the utility socket at rear of receiver.

AUTOMATIC SHUT-OFF OF AN APPLIANCE: An appliance can be shut-off automatically by connecting it to the utility socket in the same manner as described above.

The setting for automatic shut-off is the same as described in paragraph entitled "Setting Clock and Receiver for Automatic Shut-off."

As the sleep Switch has no accurate calibration the setting of this switch must be approximate. This instrument is not recommended when accurate shut-off time is required.

REMOVING AND REPLACING CLOCK KNOBS AND CRYSTAL

KNOBS: The Radio Control Switch knob, Alarm Set knob, or the Sleep Switch knob may be taken off by prying them forward. The Hand Set knob is screwed on and must be removed by rotating it in a counter-clockwise direction while at the same time holding the shaft steady with a fine pair of long nose pliers—**WARNING: Place a piece of paper between pliers and the dial crystal to avoid damage to this part.**

CRYSTAL: In order to service this part, it will be necessary to remove receiver chassis from cabinet, and to withdraw clock unit from chassis.

To remove receiver chassis from cabinet first take off the Volume and Tuning knobs. Next pry off the two retaining clips at top of cabinet back and remove the two chassis mounting screws which are accessible through slot openings at each side of cabinet back. (NOTE: Do not disturb the two externally mounted screws at bottom of cabinet back;

these screws serve to mount loop and back to chassis.) Chassis can now be withdrawn from cabinet.

To remove the clock, first slip the "Glow Lite" from its bracket. Next, remove the fibre shield around top of clock by prying off the two retaining clips located on each end of shield. Unsolder all leads coming from radio chassis to the clock. Now take off the three mounting screws that retain clock mounting bracket and entire unit can be withdrawn from receiver chassis. Remove the clock knobs as indicated in previous section.

Next, bend out the four retaining ears that hold bezel in position and remove it from clock. The bezel background and crystal can now be taken off.

SERVICING CLOCK MECHANISM

Should service of the clock mechanism be required contact your Stewart Warner Distributor for the name and address of the nearest Telechron Service Depot.

PARTS REPLACEMENT

Should it be desired to replace any other parts than those listed in the receiver parts list, they may be obtained by writing to:
Telechron Dept.
General Electric Co.
Ashland, Mass.

Please specify that unit for which parts are wanted is a C57g107 Switch Timer.

ALIGNMENT PROCEDURE

1. During the alignment of this receiver, the "GLOW LITE" tuning indicator will have to be set to a specific frequency. Since the dial scale is an integral part of the cabinet, the receiver chassis must be in the cabinet for correct positioning of the gang condenser and pointer. Before removing chassis from cabinet it will first be necessary to take off Volume Control knob, to pry off the two retaining clips at top of cabinet back and to remove the two chassis mounting screws which are accessible through slot openings at each side of cabinet back. (NOTE: Do not disturb the two externally mounted screws at bottom of cabinet back; these screws serve to mount loop and back to chassis frame.) Then turn the Tuning knob to the desired position for alignment and, taking care not to change this setting, pull Tuning knob from shaft. Now chassis can be withdrawn from cabinet without disturbing position of condenser.
2. Couple the signal generator to the receiver by connecting its output to several turns of wire formed in a circular shape so that it may be placed adjacent and parallel to the receiver loop antenna.
3. Connect an output meter across the speaker voice coil or from the plate of the 50C5 tube to B-lug through a 0.1 Mfd. condenser.
4. Set volume control at maximum volume position and use a weak signal from the signal generator.

DUMMY ANT. IN SERIES WITH SIGNAL GENERATOR	SIGNAL GENERATOR CONNECTION	SIGNAL GENERATOR FREQUENCY	RECEIVER DIAL SETTING	TRIMMER AND SLUG NUMBER	TRIMMER AND SLUG DESCRIPTION	TYPE OF ADJUSTMENT
NONE	Connect directly to coupling turn as described in step 2 above.	455 KC 400 cycle Modulation	Any point where it does not affect the signal.	1-2 3-4	2nd I.F. 1st I.F.	Adjust for maximum output. Then repeat adjustment.
NONE	Connect directly to coupling turn as described in step 2 above.	1500 KC 400 cycle Modulation	1500 KC	5	Broadcast Oscillator	Adjust for maximum output.
NONE	Connect directly to coupling turn as described in step 2 above.	1500 KC 400 cycle Modulation	Tune to 1500 KC generator signal	6	Broadcast Antenna	Adjust for maximum output.

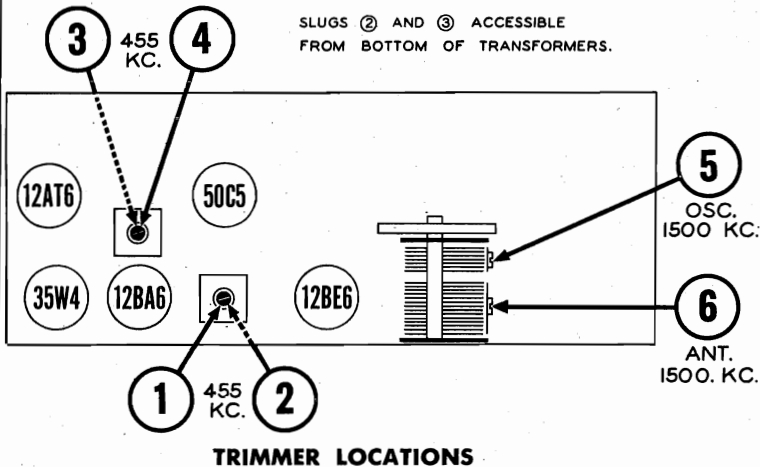

"GLOW LITE" DRIVE CORD ARRANGEMENT

Stringing of drive cord can be greatly facilitated if removal of the clock is undertaken. To string drive cord, turn the gang condenser drum to maximum counter-clockwise position and use the following parts:

- 505161 Tension spring
- 117057 Cord (2½ ft.)
- 119087 Ring
- 114955 Clip

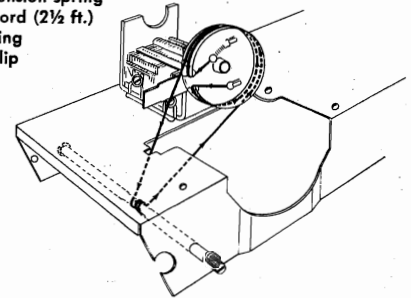

SOCKET VOLTAGES

1. All measurements made with a voltmeter having a sensitivity of 20,000 ohms per volt except where indicated by (*). The (*) symbol designates a vacuum tube voltmeter measurement.
2. Dial tuned to maximum counter-clockwise position.

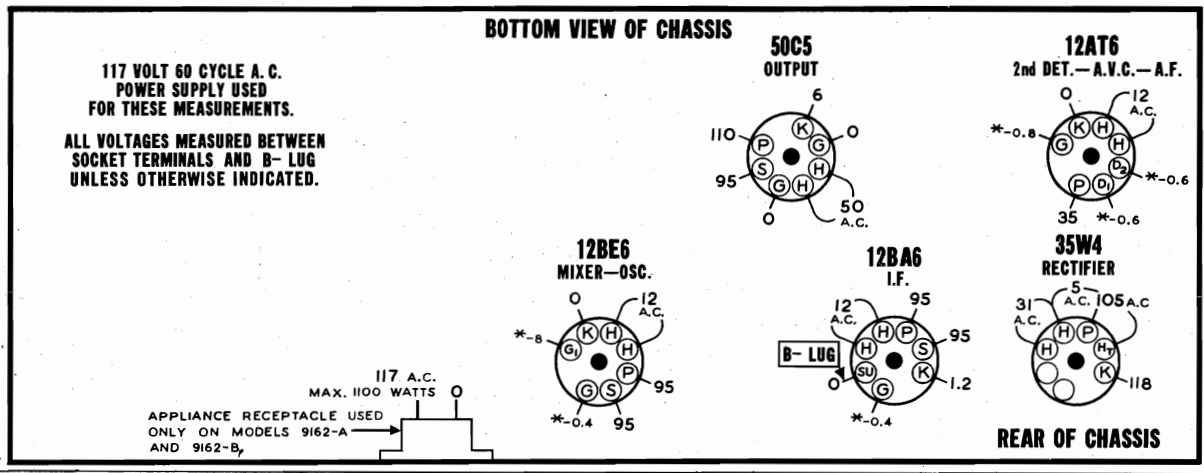

MODELS 9162-A,
9162-B

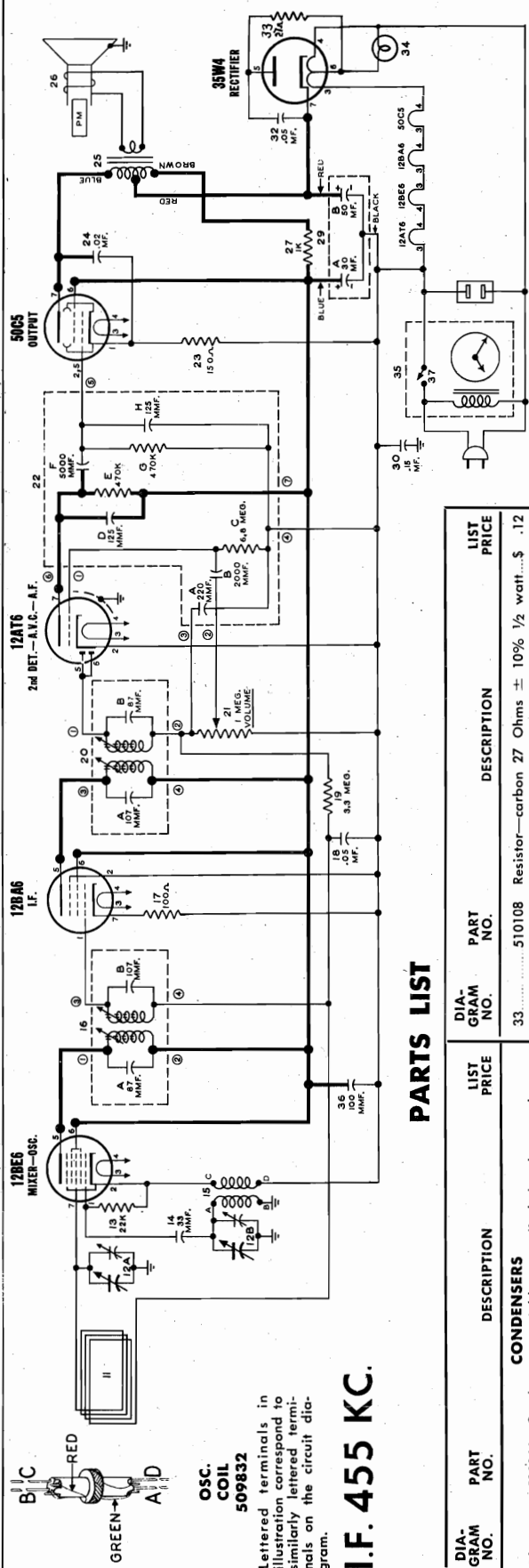

OSC. COIL
509832
Lettered terminals in illustration correspond to similarly lettered terminals on the circuit diagram.

I.F. 455 KC.

PRODUCTION CHANGES

The following change was incorporated to meet an underwriter's request and receivers incorporating this change are stamped "SERIES A" on the cabinet back.
1. Resistor 31 (330 Ohms) was removed. It formerly was wired in parallel with "GLOW LITE" #34.

The following change was incorporated to eliminate hum modulation and receivers incorporating this change are stamped "SERIES B" on the cabinet back.
1. A.V.C. condenser 18 (.05 Mfd) was disconnected from chassis ground and reconnected to B—

PARTS LIST

DIA-GRAM NO.	PART NO.	DESCRIPTION	LIST PRICE
12-A, B	520266	Condenser—variable gang (includes drum and "GLOW LITE" mfg. bracket)	3.00
14	513028	Condenser—ceramic 33 Mmfd. 500 volt	.25
16-A	509433	Coil—oscillator	1.75
16-B	509433	I.F. Transformer	1.75
18	512029	I.F. Transformer	1.75
20-A	509433	Condenser—.05 Mfd. 400 volt	1.75
20-B	509433	I.F. Transformer	1.75
22-A	509836	Condenser—ceramic 220 Mmfd. 500 volt (part of audio coupling unit)	1.00
22-B	509836	Condenser—ceramic 2000 Mmfd. 500 volt (part of audio coupling unit)	1.00
22-D	509836	Condenser—ceramic 125 Mmfd. 500 volt (part of audio coupling unit)	1.00
22-F	509836	Condenser—ceramic 5000 Mmfd. 500 volt (part of audio coupling unit)	1.00
22-H	509836	Condenser—ceramic 125 Mmfd. 500 volt (part of audio coupling unit)	1.00
24	512017	Condenser—.02 Mfd. 400 volt	.28
29-A, B	520261	Condenser—electrolytic A—30 Mfd. 150 volt B—50 Mfd. 150 volt	1.75
30	512040	Condenser—.15 Mfd. 400 volt	.35
32	512029	Condenser—.05 Mfd. 400 volt	.35
36	512503	Condenser—mica 100 Mfd. 400 volt	.25
RESISTORS			
13	510161	Resistor—carbon 22,000 Ohms 1/2 watt	.12
17	510119	Resistor—carbon 100 Ohms 1/2 watt	.12
19	510194	Resistor—carbon 33 Meg. 1/2 watt	.12
21	520263	Volume Control—1 Meg. 1/5 watt (part of audio coupling unit)	.85
22-C	509836	Resistor—carbon 6.8 Meg. 1/5 watt (part of audio coupling unit)	1.00
22-E	509836	Resistor—carbon 470,000 Ohms 1/5 watt (part of audio coupling unit)	1.00
22-G	509836	Resistor—carbon 470,000 Ohms 1/5 watt (part of audio coupling unit)	1.00
23	510122	Resistor—carbon 150 Ohms 1/2 watt	.12
27	510237	Resistor—carbon 1000 Ohms 1 watt	.16
31	510128	Resistor—carbon 330 Ohms 1/2 watt	.12
33	510108	Resistor—carbon 27 Ohms ± 10% 1/2 watt	.12
COILS AND TRANSFORMERS			
11	520270	Loop antenna and cabinet back	1.50
15	509832	Coil—oscillator	1.70
16	509433	Transformer—1st I.F. (includes condensers 16-A and 16-B)	1.75
20	509433	Transformer—2nd I.F. (includes condensers 20-A and 20-B)	1.75
25	520432	Transformer—output	2.25
OTHER ELECTRICAL PARTS			
22-A to H	509836	Audio Coupling Unit A—Condenser—ceramic 220 Mmfd. 500 v. B—Condenser—ceramic 2000 Mmfd. 500 v. C—Resistor—carbon 6.8 Meg. 1/5 w. D—Condenser—ceramic 125 Mmfd. 500 v. E—Resistor—carbon 470,000 Ohms 1/5 w. F—Condenser—ceramic 5000 Mmfd. 500 v. G—Resistor—carbon 470,000 Ohms 1/5 w. H—Condenser—ceramic 125 Mmfd. 500 v.	5.25
26	520264	Speaker—7" dynamic (#47) 6-8 v.	15
34	118921	"GLOW LITE" Lamp (Mazda #47)	12.50
35	520258-A	Lock, complete	1.20
37	520539	Switch, Radio Control (mounted on clock)	1.20
MISCELLANEOUS PARTS			
520270		Back for cabinet (includes loop antenna)	1.50
507593		Base for tube shield	.20
505165		'C' washer for pointer shaft	.02
520250-A		Cabinet for Model 9162-A (Rust and Tan) (less dial scale)	6.25
520250-B		Cabinet for Model 9162-B (Yellow and Black) (less dial scale)	6.25
520372		Clip for mounting clock shield	.05
508257		Clip for mounting electrolytic condenser	.10
505101		Clip for mounting I.F. transformers	.05
500497		Clip—retainer for cabinet back	.02
114955		Clip—retains end of dial cord	.01
520277		Clip, retains dial scale	.05
509874		Clip, retains speaker	.03
117057		Cord—drive (2 1/2 ft. required) per ft.	.05
520564		Crystal for clock face	1.00
520251		Dial scale	1.70
520539		Knob; Alarm Set, Radio Control Switch or Sleep; Time Set	.10
520252-A		Knob; Volume or tuning for Model 9162-A	.30
520252-B		Knob; Volume or tuning for Model 9162-B	.15
520423		Pointer and shield for "GLOW LITE"	.35
119087		Ring for dial	.01
509829		Rubber spacer for mounting speaker	.02
170988		Screw—#8-18 x 1/2" plastic thread cutting; retains chassis	.40
520265		Shaft; tuning	.02
520257		Shield for clock	.10
507594		Shield, tube	.15
520272		Socket for "GLOW LITE"	.50
507595		Socket (2 pin) for appliance receptacle	.20
505161		Socket—miniature (7 pin)	.08
509876		Stud for mounting speaker	.01
111456		Washer—spring washer for tuning shaft	.01

MODEL 9156-A

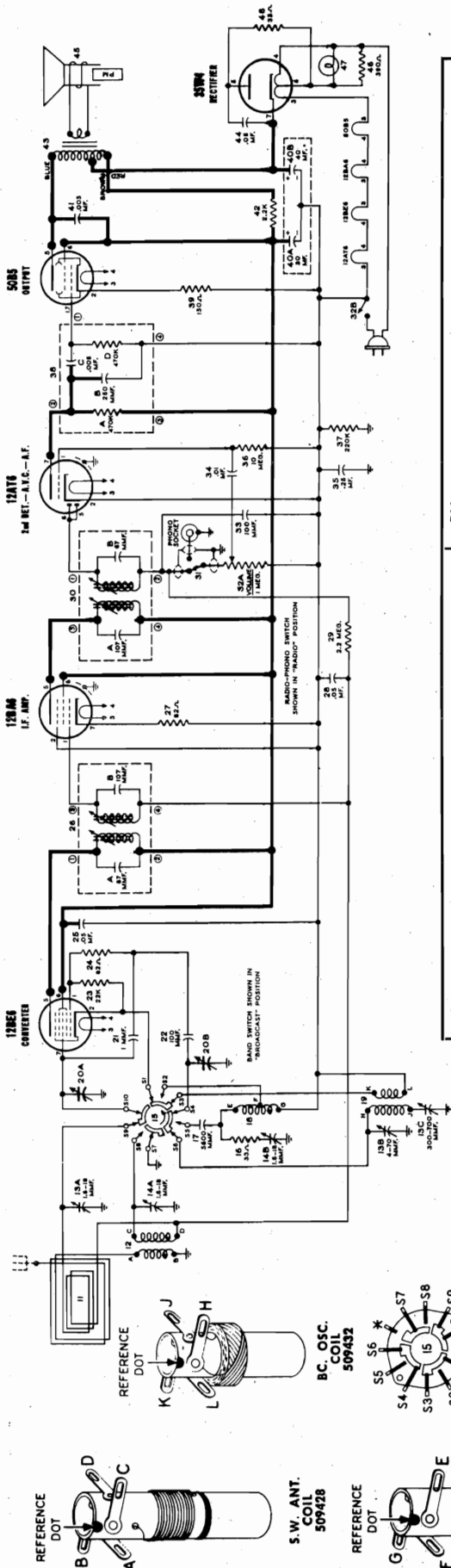

I.F.
455 KC.

*Not used; may serve as wiring junction point.

Lettered terminals in illustrations correspond to similarly lettered terminals on the circuit diagram.

PARTS LIST

DIA-GRAM NO.	PART NO.	DESCRIPTION	LIST PRICE
30-B	509433	Condenser—ceramic 87 Mmfd. (part of 2nd I.F. transformer)	1.75
33	512503	Condenser—mica 100 Mmfd. 500 volt	.25
34	512011	Condenser—.01 Mfd. 400 volt	.25
35	512047	Condenser—.25 Mfd. ±10% 400 volt	.45
38-B	505858	Condenser—ceramic 250 Mmfd. 450 volt; (part of Audio Coupling Unit)	.80
38-C	505858	Condenser—ceramic .005 Mfd. 450 volt; (part of Audio Coupling Unit)	.80
40-A, B	509426	Condenser—electrolytic A—30 Mfd. 150 volt B—40 Mfd. 150 volt	2.00
41	512007	Condenser—.05 Mfd. 600 volt	.25
44	512031	Condenser—.05 Mfd. 600 volt	.35
16	510110	Resistor—carbon 33 Ohms 1/2 watt	.16
23	510161	Resistor—carbon 22,000 Ohms 1/2 watt	.12
24	510117	Resistor—carbon 82 Ohms ±10% 1/2 watt	.12
27	510117	Resistor—carbon 82 Ohms ±10% 1/2 watt	.12
29	510193	Resistor—carbon 2.2 Meg. 1/2 watt	.12
32-A, B	509436	Volume Control—1 Meg. (with ON-OFF switch)	1.25
36	510197	Resistor—carbon 10 Meg. 1/2 watt	.12
37	510179	Resistor—carbon 220,000 Ohms 1/2 watt	.12
38-A	505858	Resistor—carbon 470,000 Ohms 1/2 watt; (part of Audio Coupling Unit)	.80
38-D	505858	Resistor—carbon 470,000 Ohms 1/2 watt; (part of Audio Coupling Unit)	.80
39	510122	Resistor—carbon 150 Ohms 1/2 watt	.12
42	510243	Resistor—carbon 220 Ohms 1 watt	.16
46	510129	Resistor—carbon 390 Ohms ±10% 1/2 watt	.12
48	510210	Resistor—carbon 33 Ohms 1 watt	.16
COILS & TRANSFORMERS			
11	509434	Loop Antenna	2.10
12	509428	Coil—short wave antenna	1.25
18	509430	Coil—short wave oscillator	1.25
19	507432	Coil—broadcast oscillator	1.25
26-A, B	509433	Transformer—1st I.F.	1.75
30-A, B	509433	Transformer—2nd I.F.	1.75
43	509424	Transformer—output	2.75
CONDENSERS			
13-A, B, C	509418	Condenser—trimmer assembly A—1.6 to 18 Mmfd. B—4 to 70 Mmfd. C—300 to 700 Mmfd.	1.20
14-A, B	509422	Condenser—trimmer assembly A—1.6 to 18 Mmfd. B—1.6 to 18 Mmfd.	.65
17	512523	Condenser—mica 5600 Mmfd. ±2% 500 volt	1.50
20-A, B	509417	Condenser—variable gang (with drum)	5.00
21	513000	Condenser—ceramic 1.0 Mmfd. 500 volt	.15
22	512503	Condenser—mica 100 Mmfd. 500 volt	.25
25	512029	Condenser—.05 Mfd. 400 volt	.35
26-A	509433	Condenser—ceramic 87 Mmfd. part of 1st I.F. transformer	1.75
26-B	509433	Condenser—ceramic 107 Mmfd. (part of 1st I.F. transformer)	1.75
28	512029	Condenser—.05 Mfd. 400 volt	.35
30-A	509433	Condenser—ceramic 107 Mmfd. (part of 2nd I.F. transformer)	1.75
OTHER ELECTRICAL PARTS			
15	509437	Switch—band	2.00
31	116896	Switch—"Radio-Phono"	.20
38-A to D	505858	Audio Coupling Unit A—Resistor—carbon 470,000 Ohms 1/2 watt B—Condenser—ceramic 250 Mmfd. 450 volt C—Condenser—ceramic .005 Mfd. 450 volt D—Resistor—carbon 470,000 Ohms 1/2 watt	.80
45	509435	Speaker—P.M. Dynamic (5")	5.50
47	118921	Lamp—dial; (Mazda #47) 6-8 volt 150 Ma.	.15
MISCELLANEOUS			
508244		Back for cabinet	.30
505368		Base for tube shield	.06
509623		Cabinet	11.00
505101		Clip for mounting I.F. transformer	.02
508149		Clip—retainer on end of dial cord	.01
508235		Clip—retains cabinet back	.03
506431		Clip—retains tuning sleeve	.12
502773		Card—dial drive (3 1/2 ft. required) per ft.	.05
509447		Dial scale	1.50
508248		Escutcheon for controls	1.40
509445		Knob—"OFF-VOLUME-ON"	.45
509444		Knob—"SW-BC"	.30
508239		Knob—"TUNE"	.30
500966		Plug for phono pick-up cable	.10
509446		Printer and dial background	.30
119087		Ring for dial cord	.01
18785		Shield—tube; miniature	.15
505367		Shield—tube; miniature	.15
507364		Socket—miniature (7 pin)	.45
160039		Socket—phono. input	.12
161384		Spring—dial cord tension	.08

PRICES SUBJECT TO CHANGE WITHOUT NOTICE

ALIGNMENT PROCEDURE

- During the alignment of this receiver, the pointer will have to be set to a specific frequency. Since the dial scale is an integral part of the cabinet, the receiver chassis must be in the cabinet for correct positioning of the gang condenser and pointer.

Before setting the pointer to the desired frequency, it will be necessary to check the position of pointer with respect to the gang condenser. To accomplish this, rotate tuning knob fully counter-clockwise until gang condenser is fully meshed. With gang in this position, pointer should be directly over the third dot or depression located on the first left hand vertical bar of the speaker grill. (See picture of the receiver on front side of this data sheet).

If the pointer is not properly positioned, hold the Tuning Knob steady and move the pointer manually to the proper place.
- Before removing chassis from cabinet, it will be necessary to take off the Volume Control knob and Tuning knob, to pry off the two retaining clips at top of cabinet back and to remove the two chassis mounting screws which are accessible through openings at bottom corners of cabinet back. (NOTE: Do not disturb the two externally mounted

screws at bottom of cabinet back; these screws serve to mount loop antenna and back to chassis frame). Then turn the tuning shaft until pointer is set to desired frequency for alignment and taking care not to change this setting, withdraw chassis from cabinet. The cabinet grill will hold the pointer, allowing it to be pulled from its shaft as chassis is withdrawn.

- Couple the signal generator to the receiver by connecting its output to several turns of wire formed in a circular shape so that it may be placed adjacent and parallel to the receiver loop antenna.
- Connect an output meter across the speaker voice coil or from the plate of the 50C5 tube to B— (see voltage chart for convenient connection point) through a 0.1 Mfd. condenser.
- Set volume control at maximum volume position and use a weak signal from the signal generator.
- After alignment has been completed and chassis reassembled in cabinet and pointer properly positioned, check calibration over entire dial and should the calibration error be objectionable, repeat procedure, exercising greater precaution in the initial setting of the pointer.

DUMMY ANT. IN SERIES WITH SIGNAL GENERATOR	SIGNAL GENERATOR CONNECTION	SIGNAL GENERATOR FREQUENCY	RECEIVER DIAL SETTING	TRIMMER AND SLUG NUMBER	TRIMMER AND SLUG DESCRIPTION	TYPE OF ADJUSTMENT
NONE	Connect directly to coupling turn as described in step 2 above.	455 KC 400 cycle Modulation	Any point where it does not affect the signal.	1-2 3-4	2nd I.F. 1st I.F.	Adjust for maximum output. Then repeat adjustment.
NONE	Connect directly to coupling turn as described in step 2 above.	1500 KC 400 cycle Modulation	1500 KC	5	Broadcast Oscillator	Adjust for maximum output.
NONE	Connect directly to coupling turn as described in step 2 above.	1500 KC 400 cycle Modulation	Tune to 1500 KC generator signal	6	Broadcast Antenna	Adjust for maximum output.

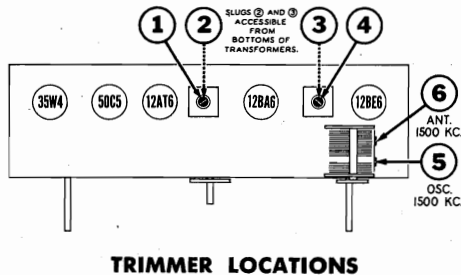

POINTER AND DRIVE CORD ARRANGEMENT

To string dial cord, turn the gang condenser drum to maximum counter-clockwise position and position pointer drum as shown in illustration and use the following parts:

- 505161 Tension spring
- 117057 Cord (2½ ft.)
- 114955 Clip

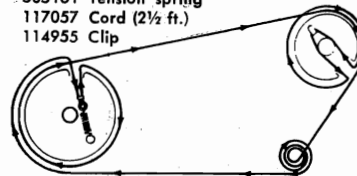

POINTER REPLACEMENT

In order to replace the pointer, it will first be necessary to remove the chassis from the cabinet as outlined in step 2 in the Alignment Procedure.

A new pointer may now be installed by inserting it, from the rear of the cabinet, into the recess at the front base of cabinet. Final positioning of pointer can only be done after chassis has been reinserted into cabinet and pointer has engaged pointer shaft. The setting must be accomplished in accordance with directions given in the second paragraph of step 1 of the Alignment Procedure.

SOCKET VOLTAGES

- All measurements made with a voltmeter having a sensitivity of 20,000 ohms per volt except where indicated by (*). The (*) symbol designates a vacuum tube voltmeter measurement.
 - Dial tuned to maximum counter-clockwise position.
- NOTE A: Grounding of center stud on tube socket is necessary to reduce capacity coupling between other pins. Oscillation may result if this ground is omitted.

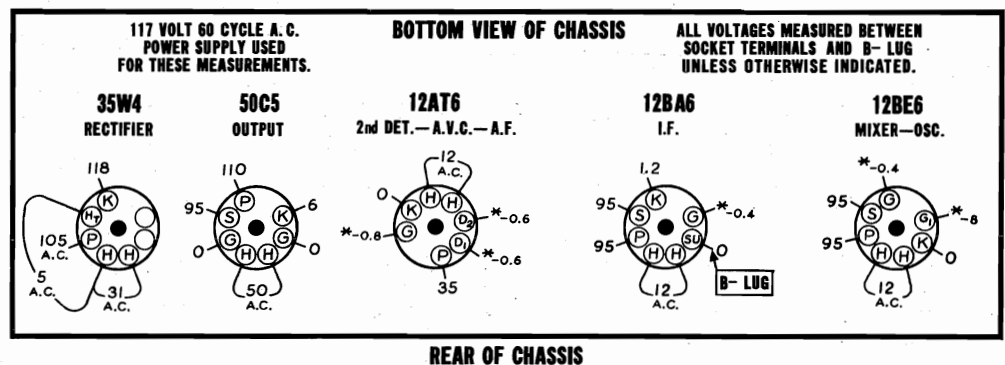

MODELS 9161-A,
9161-B, 9161-C

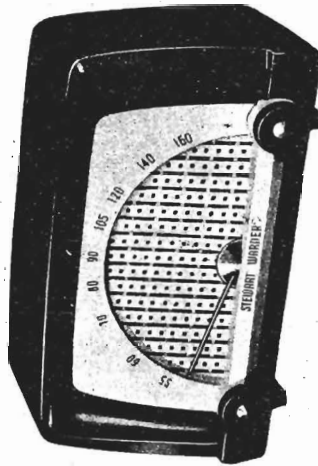

I.F. 455 KC.

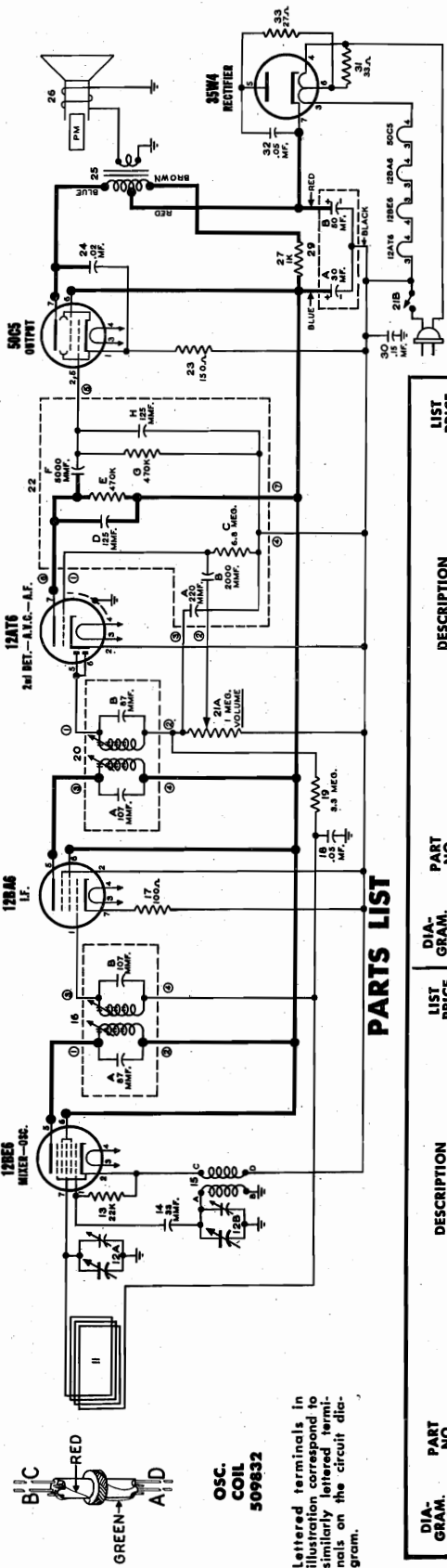

PARTS LIST

DIA. GRAM. NO.	PART NO.	DESCRIPTION	LIST PRICE
12-A, B	520117	Condenser—variable gong (includes drum)	3.75
14	513028	Condenser—ceramic 33 Mmfd. 500 volt	.25
16-A	509433	Transformer—ceramic 87 Mmfd. (part of 1st I.F. Transformer)	1.75
16-B	509433	Condenser—ceramic 107 Mmfd. (part of 1st I.F. Transformer)	.25
18	512028	Condenser—05 Mfd. 400 volt	1.75
20-A	509433	Transformer—ceramic 107 Mmfd. (part of 2nd I.F. Transformer)	1.75
20-B	509433	Condenser—ceramic 87 Mmfd. (part of 2nd I.F. Transformer)	1.00
22-A	509836	Condenser—ceramic 220 Mmfd. 500 volt (part of audio coupling unit)	1.00
22-B	509836	Condenser—ceramic 2000 Mmfd. 500 volt (part of audio coupling unit)	1.00
22-D	509836	Condenser—ceramic 125 Mmfd. 500 volt (part of audio coupling unit)	1.00
22-F	509836	Condenser—ceramic 3000 Mmfd. 500 volt (part of audio coupling unit)	1.00
22-H	509836	Condenser—ceramic 125 Mmfd. 500 volt (part of audio coupling unit)	1.00
24	512016	Condenser—electrolytic	.25
29-A, B	509837	Resistor—carbon 150 volt A—30 Mfd. 150 volt B—50 Mfd. 150 volt	2.00
30	512040	Condenser—.05 Mfd. 400 volt	.35
32	512028	Condenser—.05 Mfd. 400 volt	.25
13	510161	Resistor—carbon 22,000 Ohms 1/2 watt	.12
17	510119	Resistor—carbon 100 Ohms 1/2 watt	.12
19	510194	Resistor—carbon 3.3 Meg. 1/2 watt	.12
21-A, B	520118	Volume Control—1 Meg. (with OFF-ON switch)	1.25
22-C	509836	Resistor—carbon 6.8 Meg. 1/5 watt (part of audio coupling unit)	1.00
22-E	509836	Resistor—carbon 470,000 Ohms 1/5 watt (part of audio coupling unit)	1.00
22-G	509836	Resistor—carbon 470,000 Ohms 1/5 watt (part of audio coupling unit)	1.00
23	510122	Resistor—carbon 150 Ohms 1/2 watt	.12
27	510237	Resistor—carbon 1000 Ohms 1 watt	.16
31	510209	Resistor—carbon 33 Ohms ± 10% 1 watt	.12
33	510108	Resistor—carbon 27 Ohms ± 10% 1/2 watt	.12
COILS AND TRANSFORMERS			
11	520119	Loop antenna end cabinet back	1.75
15	509832	Coil—oscillator	1.70
CONDENSERS			
16	509433	Transformer—1st I.F. (includes condensers 16-A and 16-B)	1.75
20	509433	Transformer—2nd I.F. (includes condensers 20-A and 20-B)	1.75
25	520116	Transformer—output	2.00
OTHER ELECTRICAL PARTS			
22-A to H	509836	Audio Coupling Unit	5.00
A		Condenser—ceramic 220 Mmfd. 500 v.	1.00
B		Condenser—ceramic 2000 Mmfd. 500 v.	1.00
C		Resistor—carbon 150 v. 1/2 w.	1.00
D		Condenser—ceramic 125 Mmfd. 500 v.	1.00
E		Resistor—ceramic 470,000 Ohms 1/5 w.	1.00
F		Condenser—ceramic 5000 Mmfd. 500 v.	1.00
G		Resistor—carbon 470,000 Ohms 1/5 w.	1.00
H		Condenser—ceramic 125 Mmfd. 500 v.	1.00
		Speaker—P.M. dynamic (4")	5.00
MISCELLANEOUS PARTS			
510119		Back for cabinet (includes loop antenna)	1.75
507593		Base for tube shield	.20
520114		Bracket for pointer shaft	.10
505165		"C" Washer for tuning or pointer shaft	.02
520170-A		Cabinet for Model 9161-A (Black body, Yellow dial)	6.00
520170-B		Cabinet for Model 9161-B (Blue)	6.00
520170-C		Cabinet for Model 9161-C (Yellow body, Black dial)	6.00
505101		Clip for mounting I.F. transformer	.05
114935		Clip—retains end of dial cord	.01
509877		Clip—retains cabinet back	.02
509874		Clip—retains speaker	.03
520414		Clip—retains tuning shaft	.02
117057		Clip—dial drive (2 1/2" ft. required)	.02
520155-A		Knob for Model 9161-A (Black)	.40
520155-B		Knob for Model 9161-B (Blue)	.40
520155-C		Knob for Model 9161-C (Yellow)	.40
520123-A		Pointer for Model 9161-A (Black)	.35
520123-B		Pointer for Model 9161-B (Blue)	.35
509829		Rubber spacer for mounting speaker chassis	.02
170988		Screw—#8-18 x 1/2" plastic thread cutting; retains shaft and drum for pointer	.02
520152		Shaft, tuning	.30
507594		Shield, tube	.15
505395		Socket—miniature	.20
509876		Spring—dial cord tension	.08
509876		Fluid for mounting speaker	.01
520473		Washer, felt; fits between pointer and grill	.05

ALL PRICES ON THIS PARTS LIST ARE SUBJECT TO CHANGE WITHOUT NOTICE

MODEL 9159-A

SQUEALING OR INOPERATIVE 9159-A RADIOS

Because of inadequate plating on some 9159-A chassis, it was impossible to effect a good soldered ground connection. Over a period of time, these solder joints may develop a high resistance to ground, causing the receiver to operate improv-

erly, or become entirely inoperative. All chassis solder connections should be prodded with a screw driver to see if they will break loose. If they do, the chassis should be cleaned and the connection resoldered, using a good soldering flux.

To string dial cord, turn the main drive drum to maximum counter-clockwise position and use following parts:

- 114955 Clip on end of cord
- 502773 Cord (3 1/2 feet)
- 119087 Ring
- 161384 Tension Spring

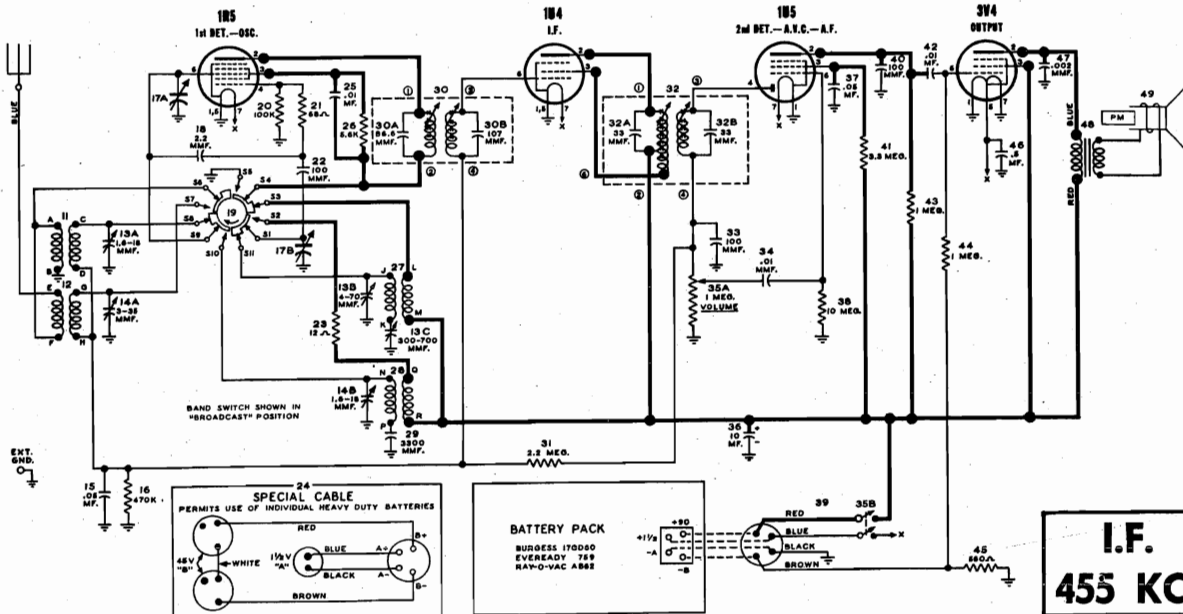
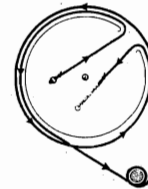

I.F.
455 KC.

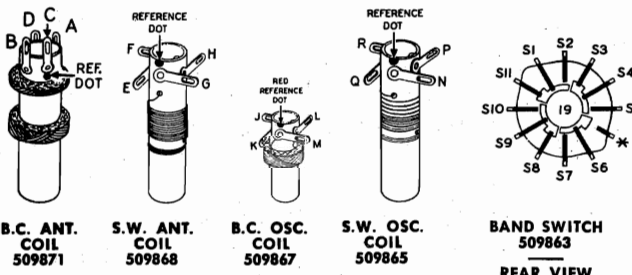

B.C. ANT. COIL 509871
S.W. ANT. COIL 509868
B.C. OSC. COIL 509867
S.W. OSC. COIL 509865
BAND SWITCH 509863
REAR VIEW

Lettered and numbered terminals in illustrations correspond to similarly lettered and numbered terminals on the circuit diagram.

PARTS LIST

DIA-GRAM NO.	PART NO.	DESCRIPTION	LIST PRICE
CONDENSERS			
13-A, B, C	509418	Condenser—trimmer assembly A—1.6 to 18 Mmfd. B—4 to 70 Mmfd. C—300 to 700 Mmfd.	\$ 1.20
14-A, B	509864	Condenser—trimmer assembly A—3 to 35 Mmfd. B—1.6 to 18 Mmfd.	.75
15	512029	Condenser—.05 Mfd. 400 volt.	.35
17-A, B	509861	Condenser—variable gang (includes drum)	6.30
18	513001	Condenser—ceramic 2.2 Mmfd. 500 volt.	.20
22	513003	Condenser—ceramic 100 Mmfd. 500 volt.	.24
25	512011	Condenser—.01 Mfd. 400 volt.	.25
29	512520	Condenser—mica 3,300 Mmfd. ±2% 500 volt.	1.30
30-A	509433	Condenser—ceramic 86.6 Mmfd. ±5% (Part of 1st IF transformer)	1.75
30-B	509433	Condenser—ceramic 107 Mmfd. ±5% (Part of 1st IF transformer)	1.75
32-A, B	509889	Condenser—ceramic 33 Mmfd. (Part of 2nd IF transformer)	2.00
33	513003	Condenser—ceramic 100 Mmfd. 500 volt.	.24
34	512011	Condenser—.01 Mfd. 400 volt.	.25
36	505174	Condenser—electrolytic 10 Mfd. 150 volt.	.90
37	512031	Condenser—.05 Mfd. 400 volt.	.35
40	513003	Condenser—ceramic 100 Mmfd. 500 volt.	.24
42	512011	Condenser—.01 Mfd. 400 volt.	.25

DIA-GRAM NO.	PART NO.	DESCRIPTION	LIST PRICE
46	512051	Condenser—.5 Mfd. ±10% 200 volt.	.45
47	512003	Condenser—.002 Mfd. 600 volt.	.25
RESISTORS			
16	510185	Resistor—carbon 470,000 Ohms 1/2 watt.	.12
20	510173	Resistor—carbon 100,000 Ohms 1/2 watt.	.12
21	510116	Resistor—carbon 68 Ohms 1/2 watt.	.12
23	510102	Resistor—carbon 12 Ohms ±10% 1/2 watt.	.16
26	510150	Resistor—carbon 5600 Ohms ±10% 1/2 watt.	.12
31	510193	Resistor—carbon 2.2 Meg. 1/2 watt.	.12
35-A, B	509862	Volume Control 1 Meg. (with OFF-ON switch)	1.40
38	510197	Resistor—carbon 10 Meg. 1/2 watt.	.12
41	510194	Resistor—carbon 3.3 Meg. 1/2 watt.	.12
43	510191	Resistor—carbon 1 Meg. 1/2 watt.	.12
44	510191	Resistor—carbon 1 Meg. 1/2 watt.	.12
45	510132	Resistor—carbon 560 Ohms ±10% 1/2 watt.	.12
COILS & TRANSFORMERS			
11	509871	Coil—Bc. Antenna	1.50
12	509868	Coil—S.W. Antenna	1.25
27	509867	Coil—Bc. Oscillator	1.20
28	509865	Coil—S.W. Oscillator	1.25
30	509433	Transformer—1st I.F. (Includes condensers 30-A and 30-B)	1.75
32	509889	Transformer—2nd I.F. (Includes condensers 32-A and 32-B)	2.00
48	509859	Transformer—output	2.25
OTHER ELECTRICAL PARTS			
19	509863	Switch—band	2.00
24	116566	Battery cable for use with individual batteries	1.60
39	509873	Battery cable	1.00
49	509435	Speaker—PM dynamic (5")	5.50
MISCELLANEOUS PARTS			
	509879	Back for cabinet	.50
	520124	Cabinet	8.50
	505101	Clip for mounting I.F. transformer	.05
	114955	Clip retainer on end of dial cord	.01
	508235	Clip—retains cabinet back	.03
	506431	Clip—retains tuning sleeve	.12
	502773	Cord—dial drive (3 1/2' required)	Per ft. .05
	509445	Knob—"OFF-VOLUME-ON"	.45
	509444	Knob—"SW-BC"	.30
	508239	Knob—"TUNE"	.30
	509878	Pointer	1.20
	119087	Ring for dial cord	.01
	509423	Sleeve—tuning	1.00
	507364	Socket—miniature (7 pin)	.24
	161384	Spring—dial cord tension	.06

PRICES SUBJECT TO CHANGE WITHOUT NOTICE

ALIGNMENT PROCEDURE

- During the alignment of this receiver, the pointer will have to be set to a specific frequency. Since the dial scale is an integral part of the cabinet, the receiver chassis must be in the cabinet for correct positioning of the gang condenser and pointer.
Before setting the pointer to the desired frequency, it will be necessary to check the position of pointer with respect to the gang condenser. To accomplish this, rotate tuning knob fully counter-clockwise until gang condenser is fully meshed. With gang in this position, pointer should be **parallel** with base of cabinet.
If the pointer is not properly positioned, hold the Tuning Knob steady and move the pointer manually to the proper place.
- Before removing chassis from cabinet, it will be necessary to take off the Volume Control knob, Tone knob, Tuning knob and cabinet back and to remove the two chassis mounting screws at bottom of cabinet. Then turn the tuning **shaft** until pointer is set to desired frequency for alignment and taking care not to change this setting, remove pointer.
- Connect an output meter across the speaker voice coil or from the plate of the 35C5 tube to B— (see voltage chart for convenient connection point) through a 0.1 Mfd. condenser.
- Connect ground lead of signal generator to B— lug.
CAUTION: If your signal generator is designed with an AC-DC power supply, connect ground lead to B— lug through a .25 Mfd. condenser. (See voltage chart for convenient B— connection.)
- Set tone control to its maximum clockwise position.
- Set volume control at maximum volume position and use a weak signal from the signal generator.
- After alignment has been completed and chassis reassembled in cabinet and pointer properly positioned, check calibration over entire dial and should the calibration error be objectionable, repeat procedure, exercising greater precaution in the initial setting of the pointer.

DUMMY ANT. IN SERIES WITH SIGNAL GENERATOR	SIGNAL GENERATOR CONNECTION	SIGNAL GENERATOR FREQUENCY	RECEIVER DIAL SETTING	TRIMMER AND SLUG NUMBER	TRIMMER AND SLUG DESCRIPTION	TYPE OF ADJUSTMENT
0.1 Mfd. Condenser	Lug on R.F. Trimmer #6	455 KC 400 cycle Modulation	Any point where it does not affect the signal.	1-2	2nd I.F.	Adjust for maximum output. Then repeat adjustment.
				3-4	1st I.F.	
200 Mmfd. Mica Condenser	External Antenna Terminal on Loop Frame	1600 KC 400 cycle Modulation	1500 KC	5	Broadcast Oscillator	Adjust for maximum output.
200 Mmfd. Mica Condenser	External Antenna Terminal on Loop Frame	1500 KC 400 cycle Modulation	Tune to 1500 KC generator signal	6	Broadcast R.F.	Adjust for maximum output.
200 Mmfd. Mica Condenser	External Antenna Terminal on Loop Frame	1500 KC 400 cycle Modulation	Tune to 1500 KC generator signal	7	Broadcast Antenna	Adjust for maximum output.

TRIMMER LOCATION CHART

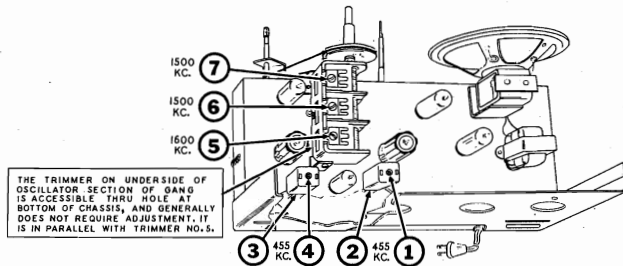

POINTER AND DRIVE CORD ARRANGEMENT

To string dial cord, turn the main drive drum to maximum counter-clockwise position and use following parts:

- 114955 Clip on end of cord
- 117057 Cord (2 feet)
- 505161 Tension Spring

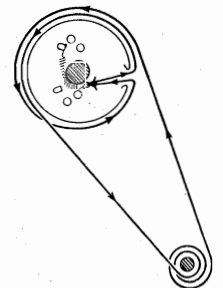

SOCKET VOLTAGES

- All measurements made with a voltmeter having a sensitivity of 20,000 ohms per volt except where indicated by (*). The (*) symbol designates a vacuum tube voltmeter measurement.
- Terminals on loop antenna are shorted together to minimize noise signal pickup.
- Dial tuned to 540 Kc.
- Volume control set to maximum with no signal.
- Tone control set at its maximum clockwise position.

NOTE A: The center stud of this tube must be connected to B— to reduce capacity coupling between pins. Oscillation may result if this connection is omitted.

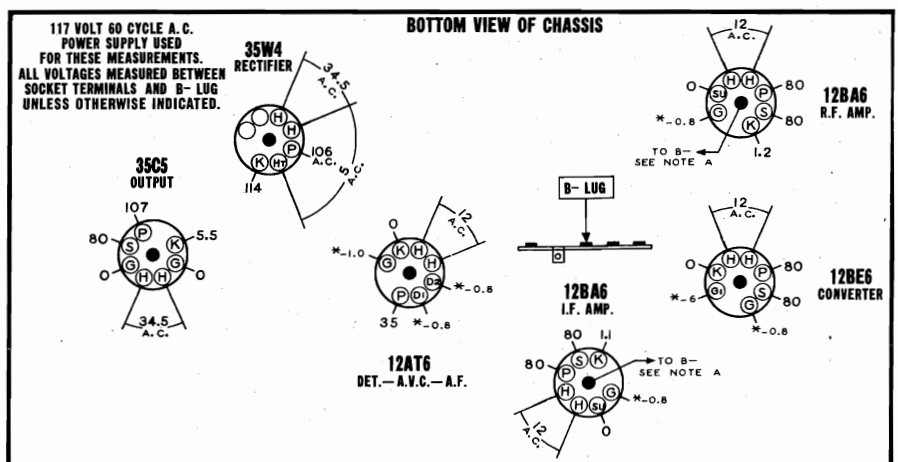

MODELS 9165-A, 9165-B

PARTS LIST

DIA-GRAM NO.	PART NO.	DESCRIPTION	LIST PRICE	DIA-GRAM NO.	PART NO.	DESCRIPTION	LIST PRICE	PART NO.	DESCRIPTION	LIST PRICE				
CONDENSERS														
12-A,B,C	520388	Condenser-variable gang (includes drum)	4.50	33-A	505858	Resistor-carbon 470,000 Ohms 1/2 watt (Part of Audio Coupling Unit)	.80	508235	Clip-retains cabinet back	.03				
14	512016	Condenser-.02 Mfd. 400 volt.	.25	33-D	505858	Resistor-carbon 470,000 Ohms 1/2 watt (Part of Audio Coupling Unit)	.80	117057	Card-dial drive (2 ft. required) per ft.	.05				
15	513405	Condenser-ceramic 15 Mmfd. 500 volt (Temperature Compensating)	.25	35	510179	Resistor-carbon 220,000 Ohms 1/2 watt.	.12	520387-A	Knob-"TONE" for Model 9165-A (Yellow)	.30				
19	512503	Condenser-mica 100 Mmfd. 500 volt.	.25	36	510121	Resistor-carbon 150 Ohms ± 10% 1/2 watt.	.16	520387-B	Knob-"TONE" for Model 9165-B (Tan)	.30				
21-A	503867	Condenser-ceramic 66 Mmfd. (Part of 1st I.F. transformer)	2.15	38	510240	Resistor-carbon 1500 Ohms ± 10% 1/2 watt.	.16	520385-A	Knob-"TUNING" for Model 9165-A (Black and Yellow)	.40				
21-B	505867	Condenser-ceramic 83 Mmfd. (Part of 1st I.F. transformer)	2.15	43,44	510210	Resistor-carbon 33 Ohms 1 watt.	.16	520385-B	Knob-"TUNING" for Model 9165-B (Rust and Tan)	.40				
23	512016	Condenser-.02 Mfd. 400 volt.	.25	11	508240	Loop antenna	2.65	520386-A	Knob-"VOLUME ON" for Model 9165-A (Black)	.25				
25-A	505867	Condenser-ceramic 83 Mmfd. (Part of 2nd I.F. transformer)	2.15	16	504692	Coil-6-Pin	1.60	520386-B	Knob-"VOLUME ON" for 9165-B (Rust)	.25				
25-B	505867	Condenser-ceramic 66 Mmfd. (Part of 2nd I.F. transformer)	2.15	20	504692	Coil-oscillator	1.50	520384-A	Pointer for Model 9165-A (Black)	.35				
28,29	512503	Condenser-mica 100 Mmfd. 500 volt.	.25	21	505867	Transformer-1st I.F. (Includes condensers 21-A and 21-B)	2.15	520384-B	Pointer for Model 9165-B (Rust)	.35				
30	512002	Condenser-.002 Mfd. 600 volt.	.20	25	505867	Transformer-2nd I.F. (Includes condensers 25-A and 25-B)	2.15	520186	Rubber washer for mounting front panel to cabinet body	.05				
32	512002	Condenser-.002 Mfd. 600 volt.	.20	40	508146	Transformer-output	2.10	18785	Screw-#8 - 3/8" x 3/8" plastic thread cutting; mounts clip for cabinet back	.02				
33-B	505858	Condenser-ceramic 250 Mmfd. 450 volt (Part of Audio Coupling Unit)	.80	33-A to D	505858	Audio Coupling Unit	.80	170820	Screw-#8 - 3/8" x 1/2" plastic thread cutting; retains cabinet back	.02				
33-C	505858	Condenser-ceramic 5000 Mmfd. 450 volt (Part of Audio Coupling Unit)	.80	42	508699	Speaker-P.M. Dynamic (5")	4.80	520389	Shaft-tuning	.15				
34	512040	Condenser-.15 Mfd. 400 volt.	.35	MISCELLANEOUS										
37	512006	Condenser-.005 Mfd. 600 volt.	.25	508244	Back for cabinet	.30	505368	Base for tube shield (miniature)	.06					
39-A,B	508147	Condenser-electrolytic A-20 Mfd. 150 v. B-30 Mfd. 150 v.	1.40	505165	"C" washer for tuning shaft	.02	520391	Cabinet (complete) for Model 9165-A (Black and Yellow)	10.00					
41	512030	Condenser-.05 Mfd. 600 volt.	.30	520392	Cabinet (complete) for Model 9165-B (Rust and Tan)	10.00	520383-A	Cabinet body for Model 9165-A (Black)	6.00					
13	510125	Resistor-carbon 220 Ohms 1/2 watt.	.12	520383-B	Cabinet body for Model 9165-B (Rust and Tan)	6.00	520382-A	Cabinet front for Model 9165-A (Black and Yellow)	3.50					
17	510185	Resistor-carbon 220,000 Ohms 1/2 watt.	.12	520382-B	Cabinet front for Model 9165-B (Rust and Tan)	3.50	505101	Clip for mounting I.F. transformer.	.05					
18	510161	Resistor-carbon 22,000 Ohms 1/2 watt.	.12	508473	Clip for mounting front panel to cabinet body	.02	508149	Clip for mounting loop antenna	.02					
22	510121	Resistor-carbon 150 Ohms ± 10% 1/2 watt.	.16	112745	Clip for mounting R.F. coil.	.01	114953	Clip-retainer on end of dial cord.	.01					
24	510191	Resistor-carbon 1 Meg. 1/2 watt.	.12	OTHER ELECTRICAL PARTS										
26	510164	Resistor-carbon 33,000 Ohms 1/2 watt (Volume and Tone control (includes ON-OFF switch))	.12	A	Resistor-carbon 470,000 Ohms 1/2 w.	}	508244	Back for cabinet	.30					
27-A,B,C	520390	Volume and Tone control (includes ON-OFF switch)	2.25	B	Condenser-ceramic 250 Mmfd. 450 v.		}	505368	Base for tube shield (miniature)	.06				
				C	Condenser-ceramic 5000 Mmfd. 450 v.			}	505165	"C" washer for tuning shaft	.02			
				D	Resistor-carbon 470,000 Ohms 1/2 w.	}			520391	Cabinet (complete) for Model 9165-A (Black and Yellow)	10.00			
					Speaker-P.M. Dynamic (5")		}		520392	Cabinet (complete) for Model 9165-B (Rust and Tan)	10.00			
								}	520383-A	Cabinet body for Model 9165-A (Black)	6.00			
						}			520383-B	Cabinet body for Model 9165-B (Rust)	6.00			
							}		520382-A	Cabinet front for Model 9165-A (Black and Yellow)	3.50			
								}	520382-B	Cabinet front for Model 9165-B (Rust and Tan)	3.50			
						}			505101	Clip for mounting I.F. transformer.	.05			
							}		508473	Clip for mounting front panel to cabinet body	.02			
								}	508149	Clip for mounting loop antenna	.02			
						}			112745	Clip for mounting R.F. coil.	.01			
							}		114953	Clip-retainer on end of dial cord.	.01			

I.F. 455 K.C.

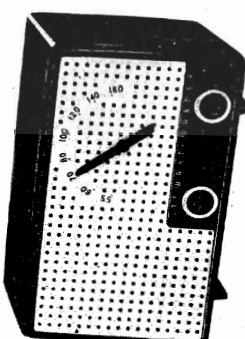

ALL PRICES ON THIS LIST ARE SUBJECT TO CHANGE WITHOUT NOTICE

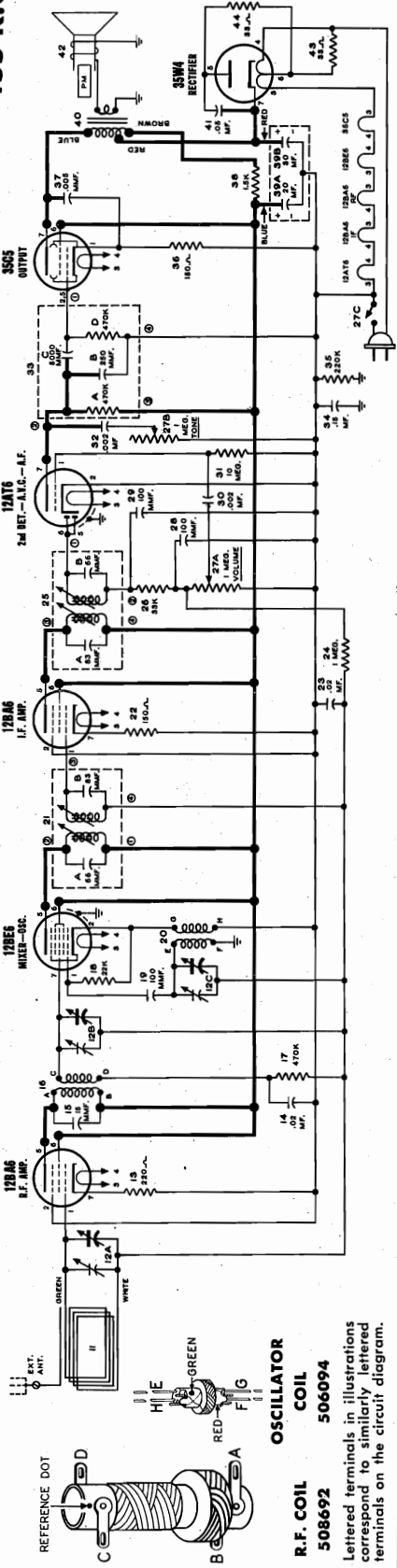

R.F. COIL 508692
OSCILLATOR COIL 506094

Lettered terminals in illustrations correspond to similarly lettered terminals on the circuit diagram.

REMOVING CHASSIS FROM CABINET

**MODELS 9170-B,
9170-C, 9170-D**

1. Raise the carrying handle until Latch Button is exposed. Press down on the button and simply separate the back and front halves of the cabinet while holding the latch button down.
2. Disconnect back retaining cord by removing center screw on receiver chassis.
3. Remove the four chassis mounting screws (see Trimmer Location

Chart) and lift chassis from cabinet.

4. Disengage one end of handle from escutcheon by squeezing together the wire retaining clip.
5. Remove the escutcheon by taking out the cross slotted screws.
6. Control knobs may now be removed by pulling them straight up.

ALIGNMENT PROCEDURE

1. Remove chassis from cabinet by following procedure described above.
2. Connect an output meter across the speaker voice coil or from the plate of the 3S4 tube to chassis through a 0.1 Mfd. condenser.
3. Set volume control at maximum and use a weak signal from the signal generator.
4. Operate the receiver from a 117 volt AC or DC line.

SIGNAL GENERATOR CONNECTIONS		SIGNAL GENERATOR FREQUENCY	RECEIVER DIAL SETTING	TRIMMER OR SLUG NUMBER	TRIMMER DESCRIPTION	TYPE OF ADJUSTMENT
CONNECT HIGH SIDE OF SIGNAL GENERATOR TO	CONNECT GROUND LEAD OF SIGNAL GENERATOR TO					
Lug on trimmer #6 at side of gang (see chart below for location of trimmer).	Any B— terminal in chassis.	455 KC	Any point where it does not affect the signal.	1 and 2	2nd I.F.	Adjust for maximum output. Then repeat adjustment.
	CAUTION If your signal generator is designed with an AC-DC type power supply, connect ground lead of signal generator to receiver through a .25 Mfd. condenser.			3 and 4	1st I.F.	
Connect directly to radiating loop. (See above for instructions on radiating loop.) Rotate and adjust loop for maximum input.		1600 KC	1600 KC	5	Broadcast Oscillator	Adjust for maximum output.
Same as above.		1500 KC	Tune to 1500 Kc. generator signal.	6	Broadcast Antenna	Adjust for maximum output.

IMPORTANT: Before undertaking alignment of the oscillator and antenna trimmers it is necessary to reassemble the chassis in the cabinet. The tuning knob should be installed on the gang condenser shaft so that when the condenser is fully meshed, the dot under the smaller 5 of the 55 on dial scale is directly opposite the pointer (gold mark on cabinet). As battery position slightly affects R.F. alignment, it is prefer-

able to have batteries in proper place. To gain access to oscillator and antenna trimmers, it will be necessary to open back of cabinet. In order to provide a coupling for the signal generator, during this part of the procedure, wind several turns of wire in a circular shape to form a radiating loop that may be placed adjacent (axes parallel) to the loop antenna. Now complete the alignment procedure as follows.

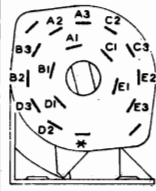
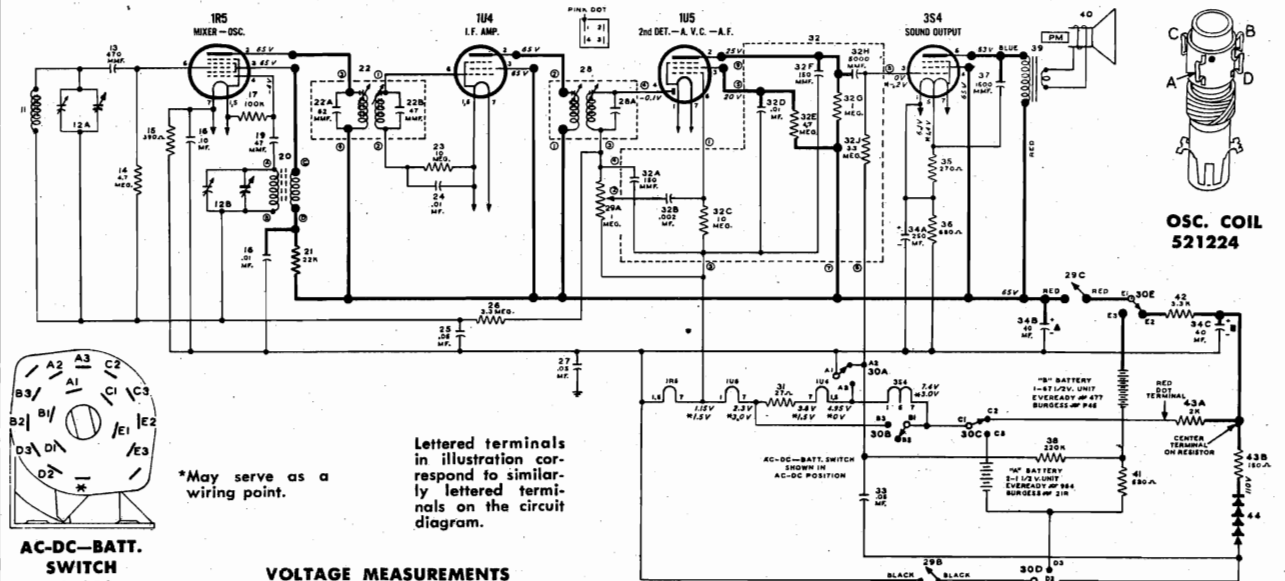

*May serve as a wiring point.

Lettered terminals in illustration correspond to similarly lettered terminals in the circuit diagram.

VOLTAGE MEASUREMENTS

All voltages measured to B— using a 20,000 ohm per volt meter with the receiver connected to a 117 volt 60 cycle power supply, except those marked with an asterisk (*). The asterisk indicates that the voltage was measured with the receiver powered by its self contained batteries. Loop terminals shorted together. No voltage reading at a tube element indicates zero voltage or voltage which cannot be accurately measured with a 20,000 ohm per volt meter.

I. F. 455 KC

MODELS 9170-B,
9170-C, 9170-D

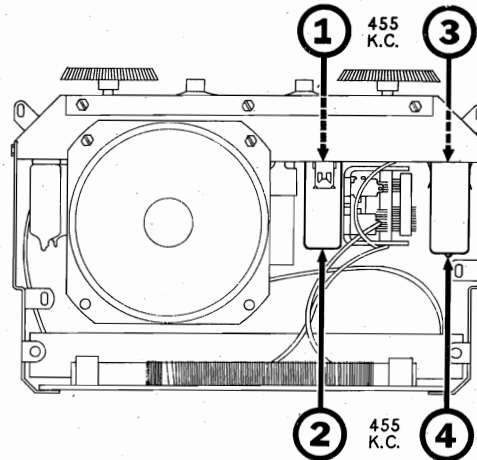
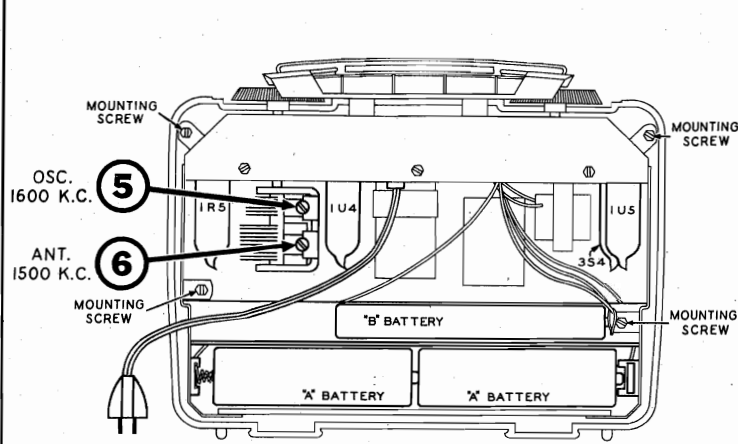

TRIMMER LOCATION CHART

PARTS LIST

DIA-GRAM NO.	PART NO.	DESCRIPTION	LIST PRICE
CONDENSERS			
12-A, B	521294	Condenser—variable gang	2.50
13	513008	Condenser—ceramic 470 Mmfd. 350 volt	.30
16	512217	Condenser—1 Mfd. 400 volt	.50
18	513022	Condenser—ceramic .01 Mfd. 450 volt	.34
19	513002	Condenser—ceramic 47 Mmfd. 500 volt	.24
22-A	521318	Condenser—ceramic 62 Mmfd. (Part of 1st I.F. transformer)	1.50
22-B	521318	Condenser—ceramic 47 Mmfd. (Part of 1st I.F. transformer)	1.50
24	513022	Condenser—ceramic .01 Mmfd. 450 volt	.34
25	512214	Condenser—.05 Mfd. 400 volt	.30
27	512214	Condenser—.05 Mfd. 400 volt	.30
28-A	521319	Condenser—ceramic 20 Mmfd. (Part of 2nd I.F. transformer)	1.50
32-A	521305	Condenser—ceramic 150 Mmfd. 500 volt (Part of Audio Coupling Unit)	1.25
32-B	521305	Condenser—ceramic .002 Mfd. 500 volt (Part of Audio Coupling Unit)	1.25
32-D	521305	Condenser—ceramic .01 Mfd. 500 volt (Part of Audio Coupling Unit)	1.25
32-F	521305	Condenser—ceramic 150 Mmfd. 500 volt (Part of Audio Coupling Unit)	1.25
32-H	521305	Condenser—ceramic 5000 Mmfd. 500 volt (Part of Audio Coupling Unit)	1.25
33	512214	Condenser—.05 Mfd. 400 volt	.30
34-A, B, C	521193	Condenser—electrolytic (less mounting bracket) A—250 Mfd. 15 volt B—40 Mfd. 150 volt C—40 Mfd. 150 volt	2.50
37	513010	Condenser—ceramic 1500 Mmfd. 350 volt	.30
RESISTORS			
14	510195	Resistor—carbon 4.7 Meg. 1/2 watt	.12
15	510129	Resistor—carbon 390 Ohms ±10% 1/2 watt	.12
17	510173	Resistor—carbon 100,000 Ohms 1/2 watt	.12
21	510161	Resistor—carbon 22,000 Ohms 1/2 watt	.12
23	510197	Resistor—carbon 10 Meg. 1/2 watt	.12
26	510194	Resistor—carbon 3.3 Meg. 1/2 watt	.12
29-A, B	521218	Volume control—1 Meg. (with On-Off switch)	1.25
31	510108	Resistor—carbon 27 Ohms ± 10% 1/2 watt	.12
32-C	521305	Resistor—carbon 10 Meg. 1/5 watt (Part of Audio Coupling Unit)	1.25
32-E	521305	Resistor—carbon 4.7 Meg. 1/5 watt (Part of Audio Coupling Unit)	1.25
32-G	521305	Resistor—carbon 1 Meg. 1/5 watt (Part of Audio Coupling Unit)	1.25
32-J	521305	Resistor—carbon 3.3 Meg. 1/5 watt (Part of Audio Coupling Unit)	1.25
35	510126	Resistor—carbon 270 Ohms ± 10% 1/2 watt	.12
36	510133	Resistor—carbon 680 Ohms ± 10% 1/2 watt	.12
38	510179	Resistor—carbon 220,000 Ohms 1/2 watt	.12
41	510133	Resistor—carbon 680 Ohms ± 10% 1/2 watt	.12
42	510146	Resistor—carbon 3300 Ohms 1/2 watt	.12
43-A, B	521210	Resistor—wire wound (include mounting bracket) A—2000 Ohms ± 5% 7 watt B—150 Ohms ± 10% 3 watt (fuse type)	1.00
COILS & TRANSFORMERS			
11	521375	Antenna—rod type (included mounting board)	2.00
20	521224	Coil—oscillator	1.50
22	521318	Transformer—1st I.F. (includes condensers 22A and 22B)	1.50
28	521319	Transformer—2nd I.F. (includes condenser 28-A)	1.50
39	521266	Transformer—output	1.75



OTHER ELECTRICAL PARTS

30-A to E	521293	Switch—AC-DC—Battery	
32-A to J	521305	Audio Coupling Unit (included condensers and resistors 32-A thru J)	1.25
40	521365	Speaker—P. M. dynamic (4")	4.00
44	508305	Selenium rectifier	1.65

CABINET PARTS

521669	Cabinet, back section; Model 9170-B—Green	4.00
521671	Cabinet, back section; Model 9170-C—Gray	4.00
521673	Cabinet, back section; Model 9170-D—Maroon	4.00
521668	Cabinet, front section; Model 9170-B—Green (includes latch and baffle)	5.25
521670	Cabinet, front section; Model 9170-C—Gray (includes latch and baffle)	5.25
521672	Cabinet, front section; Model 9170-D—Maroon (includes latch and baffle)	5.25
521268	Clip, hinge; for front and back section of cabinet	.03
521256	Clip, retains handle	.03
521263	Escutcheon plate	1.75
521273	Handle, plastic	.30
521351	Knob, "OFF" and volume	.25
521350	Knob, Tuning and Dial Scale	.25
521259	Latch	.05
521257	Latch button	.10

MISCELLANEOUS PARTS

505101	Clip for mounting I.F. transformers	.05
505314	"C" washer for latch button	.02
521228	Clip, coil mounting	.05
521230	Clip, retains mounting stud	.05
521426	Clip, retains "A" battery holder	.02
521337	Connector, "B" battery	.45
521238	Contact, "A" battery; leaf type	.03
521239	Contact, "A" battery; spring type	.03
521236	Holder, "A" battery; for leaf contact (less contact)	.15
521237	Holder, "A" battery; for spring contact (less contact)	.15
521261	Screw, #6x3/8 (plastic thread cutting); retains chassis	.02
521315	Screw, #8-32x1", philips oval head; retains escutcheon plate	.05
522014	Spring, coil; for latch button	.02
507364	Socket—miniature (7 pin)	.24
521297	Stud, mounts escutcheon plate. (fiber)	.25
89027	Washer; spring washer for latch button	.05

ALL PRICES ON THIS PARTS LIST ARE SUBJECT TO CHANGE WITHOUT NOTICE.

SPECIFICATIONS

Voltage Rating.....117 Volts, 60 Cycle
 Type of Circuit..... Superhetrodyne
 Tuning Range..... 540 KC to 1650 KC
 Maximum Appliance Load.....1100 Watts
 Intermediate Frequency.....455 KC

TUBE COMPLEMENT

1 12BE6 Oscillator and Converter
 1 12BA6 IF Amplifier
 1 12AT6 Detector-Audio Amplifier
 1 50C5 Power Output
 1 35W4 Rectifier

ALIGNMENT PROCEDURE

- Output meter across voice coil (3.2 ohm).
- Volume control at maximum for all adjustments.
- Align for maximum output. Reduce input as needed to keep output near 1.28 volts (0.5 watt).

SIGNAL GENERATOR				TUNER SETTING	ADJUST TRIMMERS TO MAXIMUM OUTPUT (in order shown)
Frequency	Coupling Capacitor	Connections to Receiver	Ground Connection		
455 kc	0.1 mfd.	12BE6 grid	B —	Rotor full open (Plates out of mesh)	Input and output slugs of IF cans
1650 kc	0.1 mfd.	12BE6 grid	B —	Rotor full mesh (Plates in mesh)	Oscillator trimmer A2
1500 kc.		Radiating Loop		1500 kc	Antenna trimmer A1

PARTS LIST

CAPACITORS

Circuit Symbol	S-C Part No.	Description
C-1	81778	Variable Condenser (30-39)
C-2	81779	40-40-20 MF—150 V Electro. (31-38)
C-3	110724	.1 MF — 400 V (32-57)
C-4	110801	.05 MF — 400 V (32-5)
C-5	110801	.05 MF — 400 V (32-4)
C-6	110291	100 MMF — 500 V (35-4)
C-7	110542	.02 MF — 400 V (32-3)
C-8	110805	.005 MF — 200 V (32-20)
C-9	110801	.05 MF — 400 V (32-5)
C-10	110291	100 MMF — 500 V (35-4)

COILS

Circuit Symbol	S-C Part No.	Description
L-1	81781	Oscillator coil (60-3)
T-2	81782	Input IF transformer (61-11)
T-3	81782	Output IF transformer (61-11)
LP-1	81783	Back Panel with Loop (125-50)

RESISTORS

Circuit Symbol	S-C Part No.	Description
R-1	149134	1500 ohms — 1 W — 20% (20-152-41)
R-2	149125	10 megohms—½ W—20% (20-106-11)
R-3	149096	150 ohms—½ W—20% (20-151-31)
R-4	149096	150 ohms—½ W—20% (20-151-31)
R-5	149121	2.2 megohms—½ W—20% (20-225-31)
R-6	149109	22K ohms—½ W—20% (20-223-11)
R-7	149091	22 ohms—½ W—20% (20-220-31)
R-8	81780	.5 megohms—Potentiometer (50-35)
R-9	149095	100 ohms—½ W—20% (20-101-31)

MISCELLANEOUS

Circuit Symbol	S-C Part No.	Description
X-1	81797	Couplate (CRL-400-001K) (36-3)
	81784	4" Speaker (80-14)
	81785	Knob — Volume Control (122-56)
	81786	Knob — Tuning (122-58)
	81776	Knob — Clock Controls
	81777	Cabinet (120-70)
	81775	Clock Dial Glass

SERVICING OF TELECHRON MOVEMENT

Telechron has established service stations which are prepared to service the movement unit when delivered by itself — that is when physically removed from the radio receiver case. Under no circumstances will the clocks be serviced when not removed from the cabinet.

To take the clock movement out of the cabinet follow the instructions given below. Remove the following:

1. Line cord from power line.
2. Tuning knob — volume control knob.
3. Back panel and chassis from cabinet.
4. Three nuts holding clock clamp shield around clock.
5. Unsolder the black, blue and green wires connected to the clock after pulling back the clock shield.
6. Before the clock can be removed from the cabinet, the slumber switch must be in the full 60 minute position and the operation selector knob must be in the "on" position.
7. Remove the clock movement by slightly turning the rim so the movement parts can pass thru the cabinet opening.

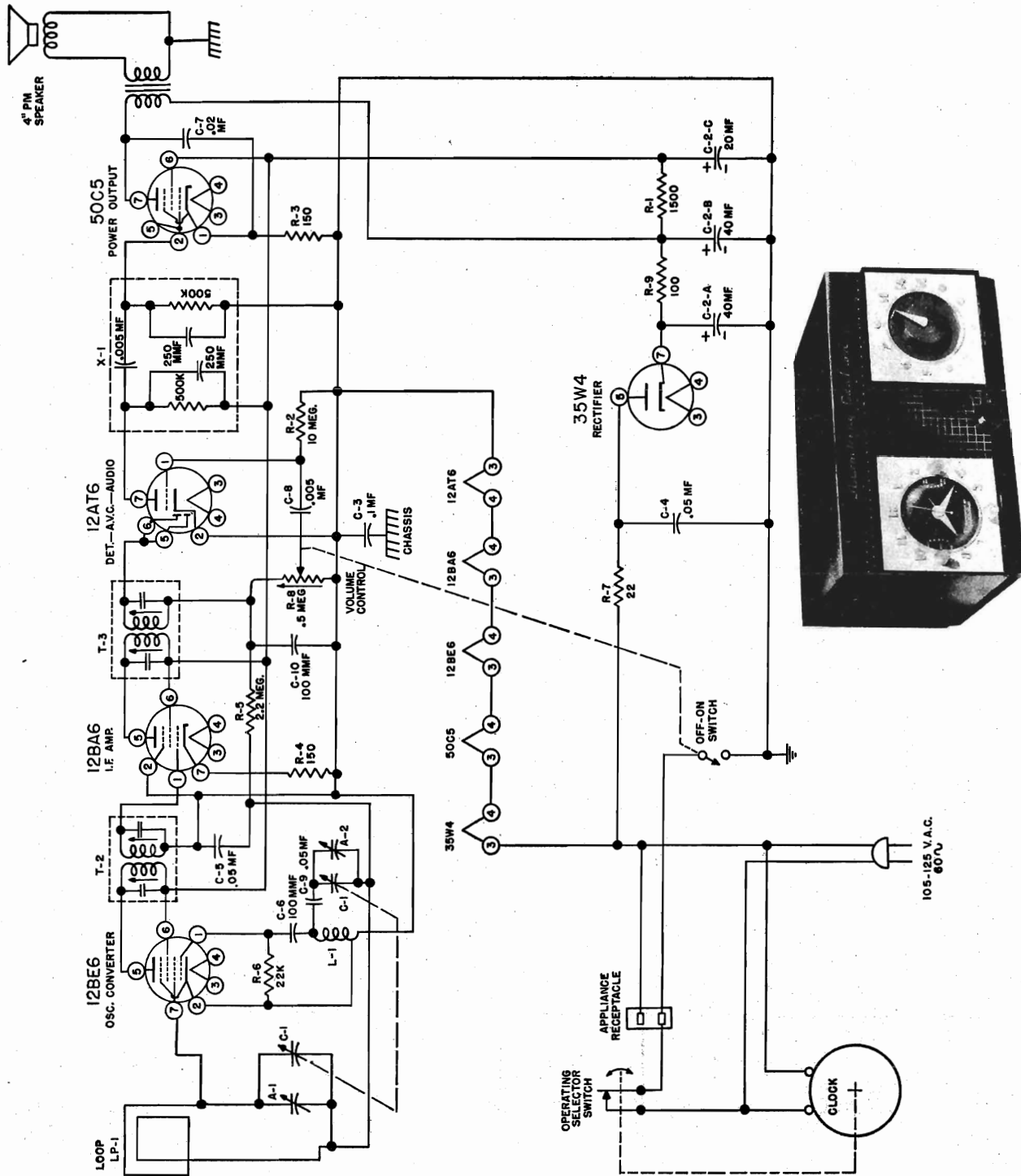

MODELS 400RPM, 400RPM2,
400RPO, Custom

ALIGNMENT CHART

An accurate, calibrated signal generator and d-c vacuum tube voltmeter are necessary in order to align this radio. A sweep frequency signal generator and an oscilloscope may be used if available, but are not required. Any attempt to align without the required equipment is certain to result in failure. The chart lists the various alignment steps. Location of the alignment points is shown on the tube location and part identification chart.

Observe the following precautions:

(A) Make all adjustments in order given.

(B) Use a non-metallic screw driver and light pressure for slug adjustments.

(C) The standard 300-ohm dummy antenna comprises a pair of resistors, one connected in series with each terminal of signal generator, of such value that the total impedance between terminals, including signal generator is 300 ohms.

(D) To use signal generator with sweep oscillator and oscilloscope, substitute steps 2A, 3A and 4A for steps 2, 3 and 4.

Band and Pointer	Signal Generator	Meter Connection	Adjustments and Notes
1. —	—	—	With tuning capacitor fully meshed: Adjust dial pointer to marker at top left of dial; adjust f-m tuning slugs flush with bottom of glass coil-forms.
2. AM HF; low (540 kc) end of dial.	455 kc, no modulation, high side to pin 7 (grid) of V-10 (6BE6) thru .01 uf capacitor, low side to chassis.	D-c VTVM to terminal 4 of L-10 and chassis. (AGC voltage).	Use least input signal to provide —1 to —1.5 volts on —3-volt scale. Adjust secondary (top) of T-3, T-5, T-7 for maximum negative voltage with 1000-ohm resistor across primary winding of transformer being adjusted. Adjust primary (bottom) of T-3, T-5, T-7 for maximum negative voltage with 1000-ohm resistor across secondary winding of transformer being adjusted.
3. FM AFC OFF; low end of dial.	10.7 mc, no modulation; high side to high side of L-1 thru .01 uf capacitor, low side to chassis.	Same as step 2.	Use least input signal to provide —1 to —1.5 volts on —3-volt scale. Adjust secondary (top), primary (bottom) of T-6 for maximum negative voltage. Leave signal generator output set to provide —2 volts, the correct signal level for step 4.
4. Same as step 3.	Same as step 3.	D-c VTVM to junction R-17 and R-18 and to chassis.	Use —3-volt scale. Adjust secondary (top) of T-6 for zero voltage between positive and negative voltage.
5. FM AFC OFF; 108 mc.	108 mc, 400 cps modulation to terminals FM and G thru 300-ohm dummy antenna (note C).	D-c VTVM to terminal 4 of L-10 and chassis. (AGC voltage).	Use least input signal to provide —1 to —1.5 volts on —3-volt scale. Adjust C-29 (FM osc.) for maximum negative voltage.
6. FM AFC OFF; 88 mc.	88 mc; otherwise same as step 5.	Same as step 5.	Check dial calibration. If incorrect, change position of C-31 in relation to L-6 (osc. coil) to obtain correct dial calibration of 88 mc and repeat steps 5 and 6 until dial calibration is correct at 108 mc and at 88 mc.
7. FM AFC OFF; 108 mc.	108 mc; otherwise same as step 5.	Same as step 5.	Use least input signal to provide —1 to —1.5 volts on —3-volt scale. Adjust C-7 (RF) C-1 (ant.) for maximum negative voltage. While adjusting C-7, rock signal generator slowly, returning to 108 mc. Recheck C-29.
8. FM AFC OFF; 100 mc.	100 mc; otherwise same as step 5.	Same as step 5.	Check dial calibration.
9. FM AFC OFF; 90 mc.	90 mc; otherwise same as step 5.	Same as step 5.	Check dial calibration. If steps 8 or 9 show incorrect dial calibration, repeat steps 1, 5, 6, 7, 8 and 9.
10. AM HF; 1650 kc.	1650 kc, 400 cps modulation to LOOP terminals through 50-ohm resistor.	Same as step 5.	Use least input signal to provide —1 to —1.5 volts on —3-volt scale. Adjust C-42C (AM osc.) for maximum negative voltage.
11. AM HF; 1400 kc.	1400 kc; otherwise same as step 10.	Same as step 5.	Use least input signal to provide —1 to —1.5 volts on —3-volt scale. Adjust C-42A (ant.) and C-42B (RF) for maximum negative voltage.
12. AM HF; 600 kc.	600 kc; otherwise same as step 10.	Same as step 5.	Use least input signal to provide —1 to —1.5 volts on —3-volt scale. Adjust L-9 (low-frequency antenna) slug for maximum negative voltage.
13. AM HF; 1000 kc.	Same as step 11.	Same as step 5.	Repeat step 11.
14. AM HF; 1000 kc.	1000 kc, 10 kc modulation; otherwise same as step 10.	A-c voltmeter across output connector TB-3.	Rock tuning slowly to center of dip in meter reading while increasing signal input to provide readable indication.
15. Same as step 14.	Same as step 14.	Same as step 14.	Adjust C-50 to center of dip in meter reading. Increase signal input if necessary to obtain readable indication on 3-volt or lower scale.

Alternate steps 2, 3 and 4 for use with sweep oscillator and oscilloscope

Band and Pointer	Signal Generator	Meter and Scope Connection	Adjustments and Notes
2A. AM HF; low (535 kc) end of dial.	455 kc, swept at 22.5 kc. High side to pin 7 (grid) of V-10 (6BE6) thru .01 uf capacitor. Low side to chassis.	D-c VTVM to terminal 4 of L-10 and chassis. (AGC voltage). Scope to pin 2 of T-5 (3rd IF, AM) and chassis.	Use least input signal to provide —1 to —1.5 volts on —3-volt scale of VTVM. Adjust primary (bottom) and secondary (top) of T-3, T-5 and T-7 for best double-trace curve.
3A. FM AFC OFF; low end of dial.	10.7 mc swept at 150 kc. High side to high side of L-1 thru .01 uf capacitor. Low side to chassis.	D-c VTVM same as step 2A. Scope to pin 2 of V-6 (6AL5) with C-22 disconnected.	Use least input signal to provide —1 to —1.5 volts on —3-volt scale of VTVM. Adjust primary (bottom) and secondary (top) of T-1, T-2, T-4 and primary (bottom) of T-6 for best double-trace curve. Reconnect C-22 before step 4A.
4A. Same as step 3A.	Same as step 3A.	D-c VTVM same as step 2A. Scope to junction of R-17 and R-18.	Use least input signal to provide —1 to —1.5 volts on —3-volt scale of VTVM. Adjust secondary (top) of T-6 for crossover.

VOLTAGE CHART

SELECTOR SWITCH POSITION	TUBE			TERMINAL								
	SYMBOL	TYPE	FUNCTION	1	2	3	4	5	6	7	8	9
FM	V-1	6CB6	FM-RF Ampl.	-.1	0	0	AC 6.3	170	150	0	-	-
FM	V-2	6AU6	FM Mixer	0	0	0	AC 6.3	200	200	4.8	-	-
Any	V-3	6BA6	1st IF Ampl.	-.1	0	0	AC 6.3	190	140	1.0	-	-
Any	V-4	6BA6	2nd IF Ampl.	0	1.8	0	AC 6.3	190	140	2.5	-	-
FM	V-5	6AU6	FM Limiter AM Detector	-.5	0	0	AC 6.3	90	20	0	-	-
FM	V-6	6AL5	FM Ratio Det.	.9	.9	0	AC 6.3	0	0	0	-	-
FM	V-7	12AT7	FM Osc., Var. Reactance	130	0	2.5	0	0	175	-2	0	AC 6.3
FM	V-8	6AL7	Tuning Indic.	0	0	350	-.8	-.8	-.8	AC 6.3	.6	-
AM	V-9	6BA6	AM-RF Ampl.	0	0	AC 6.3	0	190	110	1	-	-
AM	V-10	6BE6	AM Converter	-10	0	0	AC 6.3	190	110	-.5	-	-
FR-AES	V-11	12AU7	AF Amplifier	22	-.4	0	30	30	20	-.4	0	30
Any	V-12	12AX7	AF Amplifier	200	0	21	30	30	250	0	2.4	30
Any	V-13	12AT7	AF Amplifier Phase Inv.	200	100	100	301	30	100	0	.2	30
Any	V-14	6F6	Power Output	0	30	400	340	0	0	30	30	-
Any	V-15	6F6	Power Output	0	30	400	30	0	0	30	30	-
Any	V-16	5U4G	Rectifier	NC	400	NC	AC 380	NC	AC 380	NC	400	-

NOTES: No signal input. Power supply 117 volts, 60 cps. Tuning capacitor fully meshed—540 kc end of dial. Voltages measured to chassis (ground). A-c voltages measured using 1000 ohm-per-volt voltmeter. D-c voltages measured using vacuum-tube voltmeter. NC indicates no connection. Variations of $\pm 10\%$ in voltage readings may be obtained due to variation in tubes, resistors, etc.

V-11, V-12, V-13 heater voltage 6.3 volts AC measured between terminals 4 or 5 and 9; V-14, V-15 heater voltages 6.3 volts AC measured between terminals 2 and 7; V-16 filament voltage 5.0 volts AC measured between terminals 2 and 8.

GENERAL ASSEMBLY

	R.P.O.	RPM	RPM2
BAFFLE — SPEAKER	102012	102012	102012
CABINET ASSEMBLY	108301	108321	108335
CABLE ASSEM. — SPEAKER	109054	109054	109054
CHASSIS ASSEMBLY	112621	112621	112621
DOORS (PAIR)	81888	81924	
ESCUTCHEON	125607	125607	125607
KNOB — LOUDNESS	134625	134625	134625
KNOB — TUNING	134625	134625	134625
KNOB — SELECTOR	134624	134624	134624
KNOB — BASS	134626	134626	134626
KNOB — TREBLE	134627	134627	134627
LOCK WASHER — SPKR. MTG.	526081	526081	526081
PILOT LAMP	29956	29956	29956
LAMP CAP — (RED)	801401	801401	801401
RECORD CHANGER	100941	100941	100941
SCREW CHASSIS MTG.	203549	203549	203549
SCREW — ESCUTCHEON	163653	163653	163653
SCREW — SPKR. MTG.	511991	511991	511991
SPKR. ASSEMBLY	100942	100942	100942
WASHER — SPEAKER MTG.	525571	525571	525571

MODELS 400RPM, 400RPM2,
400RPO, Custom

TUBE COMPLEMENT

Circuit Symbol	S-C Part No.	Description
V-1	162092	6CB6 FM-RF Amp.
V-2	162032	6AU6 FM Mixer
V-3	162012	6BA6 1st I.F. Amp.
V-4	162012	6BA6 2nd I.F. Amp.
V-5	162032	6AU6 FM Limiter and AM Det.
V-6	162022	6AL5 FM Ratio Det.
V-7	162067	12AT7 FM Osc. and Var. Reactance
V-8	162064	6AL7 Tuning Ind.
V-9	162012	6BA6 AM-RF Amp.
V-10	162013	6BE6 AM Converter
V-11	162042	12AU7 AM Amp.
V-12	162070	12AX7 AF Amp.
V-13	162067	12AT7 AF Amp. and Phase Det.
V-14	162112	6F6 Power Output
V-15	162112	6F6 Power Output
V-16	162107	5U46 Rectifier

CAPACITORS

Circuit Symbol	S-C Part No.	Description	Voltage
C-1	110045	1-12 uuf	
C-2	110410	27 uuf, NPO	400
C-3	110694	100 uuf, GP	500
C-5	110818	1000 uuf	500
C-6	110694	100 uuf, GP	500
C-7	110045	1-12 uuf	
C-8	110471	22 uuf, NPO	500
C-9	110694	100 uuf, GP	500
C-10	110818	1000 uuf	500
C-11	110586	5000 uuf	450
C-12	110540	.01 uf	400
C-13	110540	.01 uf	400
C-14	110586	5000 uuf	450
C-15	110540	.01 uf	400
C-16	110540	.01 uf	400
C-17	110586	5000 uuf	450
C-18	110540	.01 uf	400
C-19	110817	2200 uuf	400
C-20	110463	330 uuf, GP	350
C-21	110586	5000 uuf	450
C-22	111093	5 uf	50
C-23	110463	330 uuf, GP	350
C-24	110463	330 uuf, GP	350
C-25	110815	1000 uuf	500
C-26	110818	1000 uuf	500
C-27	110818	1000 uuf	500
C-28	110439	2.2 uuf, NPO	500
C-29	110045	1-12 uuf	
C-30	110584	5 uuf, NPO	500
C-31	110407	33 uuf, NPO	400
C-32	110816	33 uuf, N220	400
C-33	110458	47 uuf, GP	500
C-34	110818	1000 uuf	500
C-35	110453	220 uuf, GP	500
C-36	110439	2.2 uuf, GP	500
C-37	110818	1000 uuf	500
C-38	110694	100 uuf, GP	500
C-39	110815	1000 uuf	500
C-40	110815	1000 uuf	500
C-41	110548	.22 uf	400
C-42	110121	AM Tuning Variable	
C-43	110661	.1 uf	200
C-44	110586	5000 uuf	450
C-45	110540	.01 uf	400
C-46	110661	.1 uf	200
C-47	110413	5 uuf, N750	400
C-48	110694	100 uuf, GP	500
C-49	110540	.01 uf	400
C-50	110056	30-270 uuf	350

Circuit Symbol	S-C Part No.	Description	Voltage
C-51	110458	47 uuf, GP	500
C-52	110661	.1 uf	200
C-53	110544	.047 uf	400
C-54 Radio*	110540	.01 uf	400
C-55	110543	.033 uf	400
C-56	110538	4700 uuf	400
C-57	110676	750 uuf	500
C-58	110544	.047 uf	400
C-59	110542	.022 uf	400
C-60	110676	750 uuf, GP	350
C-61	110410	27 uuf, NPO	400
C-62	110543	.033 uf	400
C-63	111609	(20 uf	25
		(20 uf	25
		(20 uf	450
		(15 uf	450
C-64	110543	.033 uf	400
C-65	110410	27 uuf, NPO	400
C-66	110538	4700 uuf	400
C-67	110455	470 uuf	350
C-68	35590	(30 uf	350
		(40 uf	450
		(50 uf	50
		(15 uf	300
C-69	110455	470 uuf	350
C-70	110538	4700 uuf	400
C-71	110661	.1 uf	200
C-72	110546	.1 uf	400
C-73	110546	.1 uf	400
C-74	110555	.01 uf	600
C-75	46320	(30 uf	500
		(30 uf	500
C-54 SR-405*	110661	.1 mf	200

RESISTORS

Circuit Symbol	S-C Part No.	Resistance	Watt	Tol.
R-1	149119	1 Megohm	1/2 W	20%
R-3	149400	6800 ohms	1 W	10%
R-4	149113	100K ohms	1/2 W	20%
R-5	28162	2200 ohms	1/2 W	10%
R-6	149101	1K ohms	1/2 W	20%
R-7	28144	68 ohms	1/2 W	10%
R-8	28170	10K ohms	1/2 W	10%
R-9	149101	1K ohms	1/2 W	20%
R-10	28144	68 ohms	1/2 W	10%
R-11	28148	150 ohms	1/2 W	10%
R-12	149108	15K ohms	1/2 W	20%
R-13	149101	1K ohms	1/2 W	20%
R-14	28177	47K ohms	1/2 W	10%
R-15	28184	270K ohms	1/2 W	10%
R-16	149385	100K ohms	1/2 W	10%
R-17	149095	100 ohms	1/2 W	20%
R-18	149234	22K ohms	1/2 W	5%
R-19	28168	6800 ohms	1/2 W	10%
R-20	28168	6800 ohms	1/2 W	10%
R-21	28187	470K ohms	1/2 W	10%
R-22	149101	1K ohm	1/2 W	20%
R-23	149402	10K ohms	1 W	10%
R-24	149107	10K ohms	1/2 W	20%
R-25	149101	1K ohm	1/2 W	20%
R-26	28152	330 ohms	1/2 W	10%
R-27	28150	220 ohms	1/2 W	10%
R-28	149113	100K ohms	1/2 W	20%
R-29	149058	27K ohms	2 W	10%
R-30	149101	1K ohm	1/2 W	20%
R-31	28164	3300 ohms	1/2 W	10%
R-32	149119	1 Megohm	1/2 W	20%
R-33	28144	68 ohms	1/2 W	10%
R-34	149051	4700 ohms	2 W	10%
R-35	28162	2200 ohms	1/2 W	10%

MODELS 400RPM, 400RPM2, 400RPO, Custom

Circuit Symbol	S-C Part No.	Resistance	Watt	Tol.
R-36	149095	100 ohms	½ W	20%
R-37	149109	22K ohms	½ W	20%
R-38	28166	4700 ohms	½ W	10%
R-39	149121	2.2 Megohms	½ W	20%
R-40	28183	220K ohms	½ W	10%
R-41	28183	220K ohms	½ W	10%
R-42	28179	68K ohms	½ W	10%
R-43	28190	820K ohms	½ W	10%
R-44	149122	3.3 Megohms	½ W	20%
R-45	28177	47K ohms	½ W	10%
R-46	28187	470K ohms	½ W	10%
R-47	28177	47K ohms	½ W	10%
R-48	149122	3.3 Megohms	½ W	20%
R-49	28179	68K ohms	½ W	10%
R-50	28183	220K ohms	½ W	10%
R-51*	149385	100K ohms	½ W	10%
R-52	28174	27K ohms	½ W	10%
R-53	149385	100K ohms	½ W	10%
R-54	149122	3.3 Megohms	½ W	20%
R-55	149122	3.3 Megohms	½ W	20%
R-59	28177	47K ohms	½ W	10%
R-60	28187	470K ohms	½ W	10%
R-61	145627	Loudness Control		
R-62	149385	100K ohms	½ W	10%
R-63	149107	10K ohms	½ W	20%
R-64	28174	27K ohms	½ W	10%
R-65	28163	2700 ohms	½ W	10%
R-66	28175	33K ohms	½ W	10%
R-67	28187	470K ohms	½ W	10%
R-68	28187	470K ohms	½ W	10%
R-69	145628	5 Megohms	Dual Pot.	
R-71	28177	47K ohms	½ W	10%
R-72	28177	47K ohms	½ W	10%
R-73	28164	3300 ohms	½ W	10%
R-74	149386	150K ohms	½ W	10%
R-75	28184	270K ohms	½ W	10%
R-76	28171	12K ohms	½ W	10%
R-77	28163	2700 ohms	½ W	10%
R-78	28177	47K ohms	½ W	10%
R-79	149108	15K ohms	½ W	20%
R-80	28166	4700 ohms	½ W	10%
R-81	28177	47K ohms	½ W	10%
R-82	28183	220K ohms	½ W	10%
R-83	28183	220K ohms	½ W	10%
R-84	46369	350 ohms	5 W	
R-85	28156	680 ohms	½ W	10%
R-86	28177	47K ohms	½ W	10%
R-88	149402	10K ohms	1 W	10%
R-89	46486	100 ohms	2 W	
R-90	149612	(750 ohms 2500 ohms)	6 W 11.9 W	
R-91	149424	2.7 ohms	1 W	10%
R-92	149424	2.7 ohms	1 W	10%
R-93	149086	47K ohms	2 W	20%
R-94*	149113	100 ohms	½ W	20%

*R-51 and R-94 used on Custom 400—omitted on SR 405

COILS

Circuit Symbol	S-C Part No.	Description
L-1	114097	Antenna coil (FM)
L-2	114693	RF Choke
L-3	114098	RF Coil (FM)
L-4	114707	RF Choke
L-5	114618	RF Choke
L-6	114098	Osc. Coil (FM)
L-7	114620	RF Coil
L-8	114707	RF Choke
L-9	114122	Ant. Coil (FM)
L-10	114095	RF Coil (AM)
L-11	114123	Osc. Coil (AM)
L-12	161044	(10kc filter) Reactor

TRANSFORMERS

Circuit Symbol	S-C Part No.	Description
T-1	114363	First IF-FM
T-2	114363	Second IF-FM
T-3	114414	Second IF-AM
T-4	114363	Third IF-FM
T-5	114414	Third IF-AM
T-6	114404	Ratio Detector
T-7	114414	First IF-AM
T-8	161337	Output transformer
T-9	161776	Power transformer

MISCELLANEOUS

Circuit Symbol	S-C Part No.	Description
F-1	25156	Fuse, 3 amp., 3AG
FL-1	110478	Filter assembly
I-1	30933	Dial Lamp
I-2	30933	Dial Lamp
J-1	31539	Twin input jack
J-2	31539	Twin input jack
J-3	31539	Twin input jack
J-4	152038	A-c socket
J-5	152033	Relay Power Jack
J-6	34421	Cabinet Lamp Jack
P-1	30224	Plug used for J1, J2, J3 and J6
S-1	158652	Selector switch

A.C. Cord and Plug	46302
Dial Bracket—Right	105715
Dial Bracket—Left	105716
Dial Glass	122600
Grommet—A.C. Cord	131024
Grommet—Dial Glass	131015
Pointer—Dial	144602
Tuning Shaft Assembly—Flywheel	150604

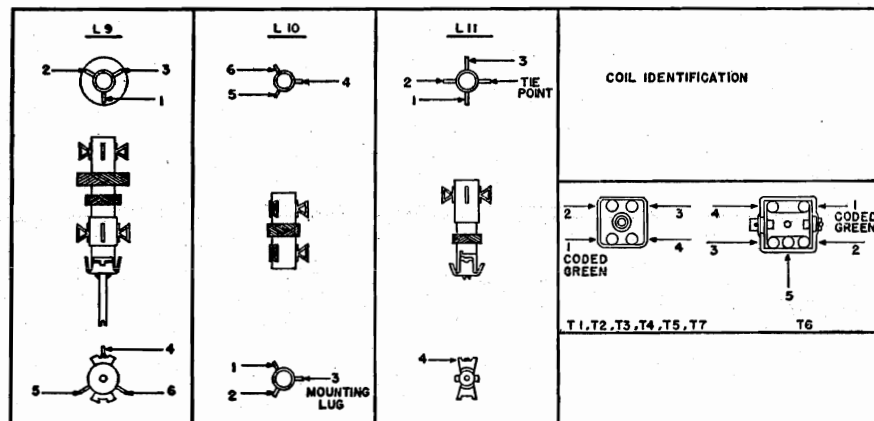

MODELS 400RPM, 400RPM2,
400RPO, Custom

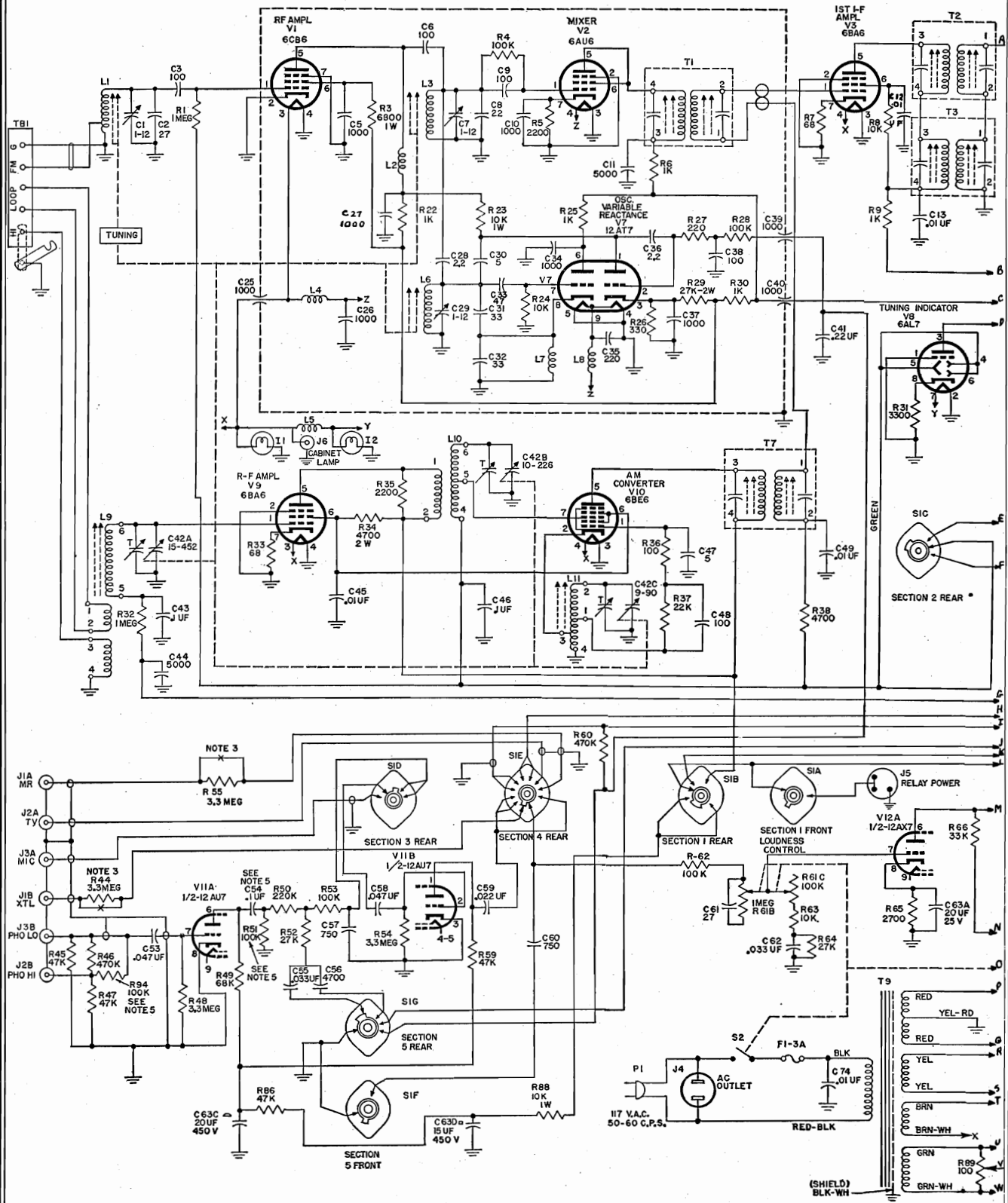

MODELS 400RPM, 400RPM2, 400RPO, Custom

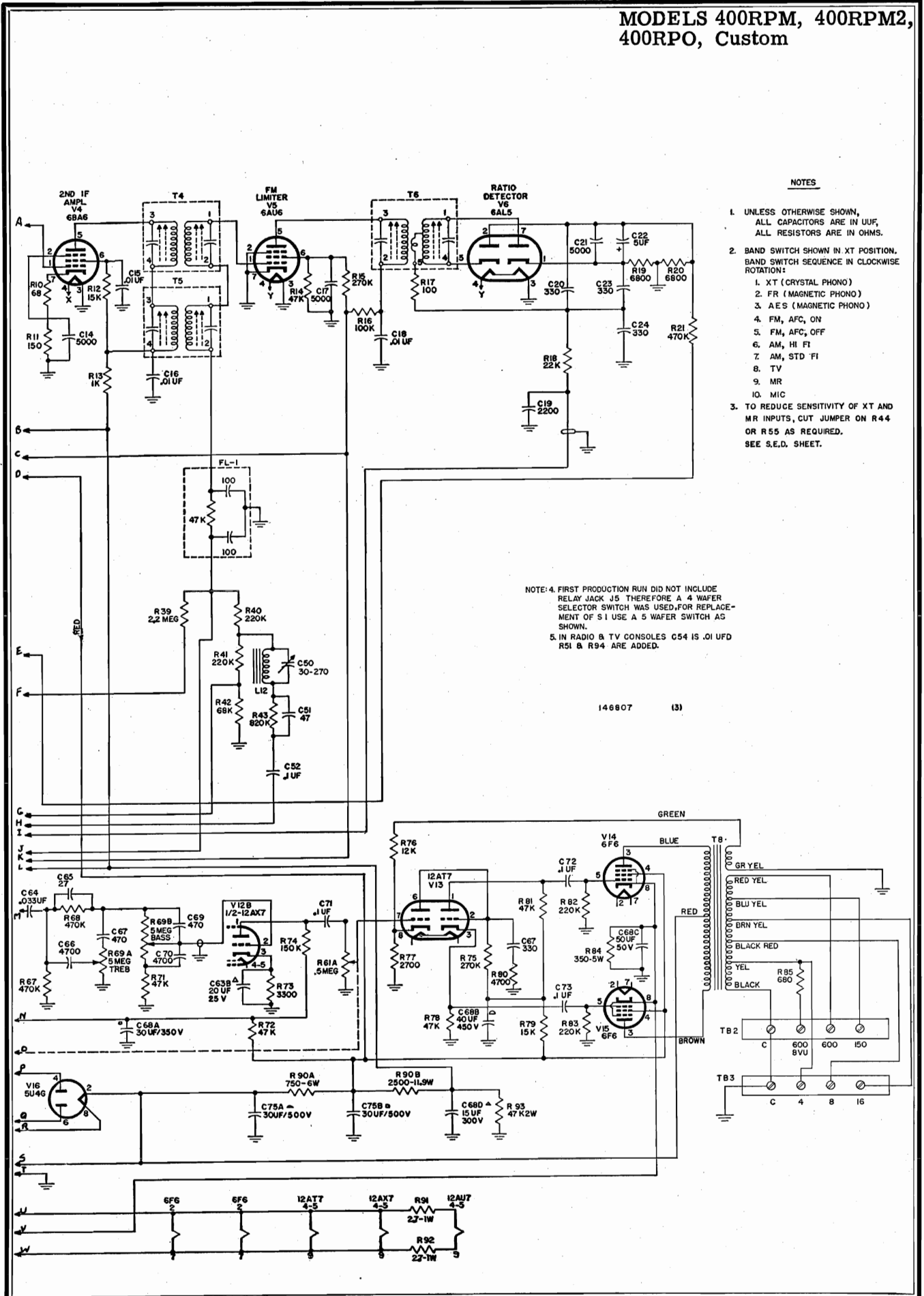

NOTES

1. UNLESS OTHERWISE SHOWN, ALL CAPACITORS ARE IN UUF, ALL RESISTORS ARE IN OHMS.
2. BAND SWITCH SHOWN IN XT POSITION. BAND SWITCH SEQUENCE IN CLOCKWISE ROTATION:
 1. XT (CRYSTAL PHONO)
 2. FR (MAGNETIC PHONO)
 3. AES (MAGNETIC PHONO)
 4. FM, AFC, ON
 5. FM, AFC, OFF
 6. AM, HI FI
 7. AM, STD FI
 8. TV
 9. MR
 10. MIC
3. TO REDUCE SENSITIVITY OF XT AND MR INPUTS, CUT JUMPER ON R44 OR R55 AS REQUIRED. SEE S.E.D. SHEET.

NOTE: 4. FIRST PRODUCTION RUN DID NOT INCLUDE RELAY JACK J5 THEREFORE A 4 WAFER SELECTOR SWITCH WAS USED. FOR REPLACEMENT OF S1 USE A 5 WAFER SWITCH AS SHOWN.
 5. IN RADIO & TV CONSOLES C54 IS .01 UFD R51 & R94 ARE ADDED.

146807 (3)

MODELS 511B, 511H,
511M, 512BR, 512CH,
512GR, 512RE, 512YE,
Ch. 1-601-1

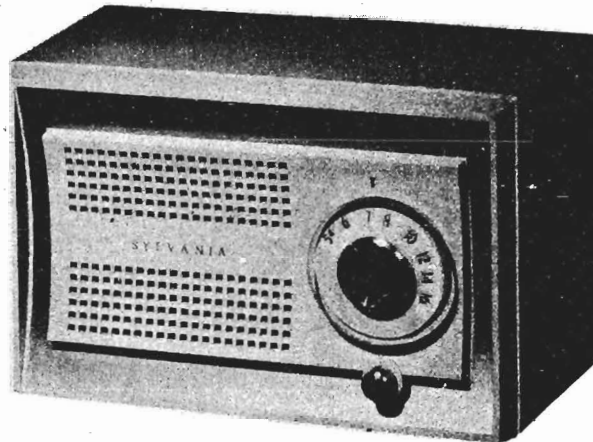

SPECIFICATIONS

POWER SUPPLY

105-125 Volts AC or DC, 35 Watts

FREQUENCY RANGE540-1650 Kc.

INTERMEDIATE FREQUENCY455 Kc.

LOUDSPEAKER.... 5" P. M., 1. 47 Oz. Magnet

SYLVANIA TUBE COMPLEMENT

Function	Type
Oscillator-Mixer	12BE6
I. F. Amplifier	12BA6
Detector - A. V. C. - 1st A. F.	12AT6
Audio Output	50C5
Rectifier	35W4

ALIGNMENT PROCEDURE

PRELIMINARY INSTRUCTIONS

Allow chassis and signal generator several minutes warm-up.

Connect an A. C. Voltmeter across voice coil terminals and set volume control to full volume position.

Keep generator output at lowest useable level to prevent A. V. C. action from interfering with accurate alignment.

2. Tune amplitude modulated signal generator to 455 Kc. Connect generator output leads to "Neg. B" and through a 0.1 Mfd. capacitor to pin 7 (control grid) of the 12BE6 Oscillator-Mixer tube.
3. Align I. F. transformers T1 and T2 by adjusting first the cores accessible from under the chassis, then the top cores. Repeat this operation until a maximum meter reading is obtained.

I. F. ALIGNMENT

1. Set the variable tuning capacitor to a point near 1,000 Kc. where no signals are heard.

R. F. ALIGNMENT

1. Turn variable tuning capacitor counter-clockwise to minimum capacity setting.

PAGE 23-2 SYLVANIA

**MODELS 511B, 511H, 511M,
512BR, 512CH, 512GR, 512RE,
512YE, Ch. 1-601-1**

- | | |
|--|--|
| <ol style="list-style-type: none"> 2. Tune generator, connected as above, to 1650 Kc. 3. Adjust oscillator trimmer C4 for maximum output. 4. Connect generator to a Hazeltine loop so | <ol style="list-style-type: none"> as to radiate a 1450 Kc. signal into the receiver. 5. Tune receiver to 1450 Kc. 6. Tune antenna trimmer C2 to obtain maximum output. |
|--|--|

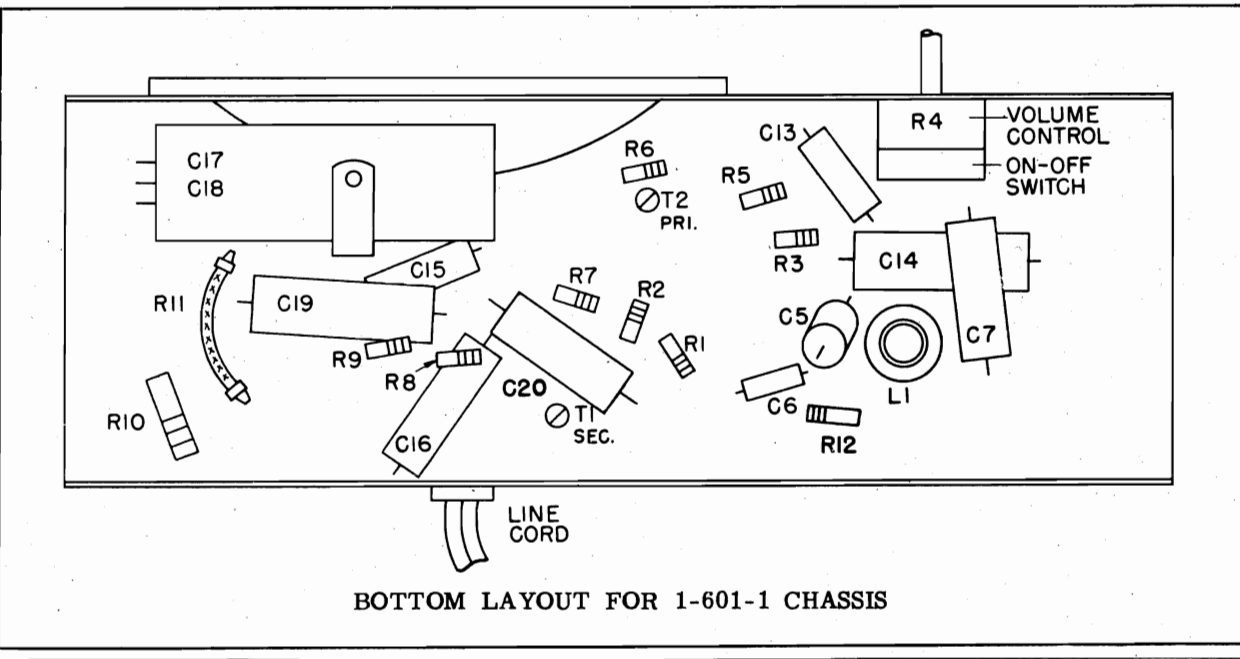
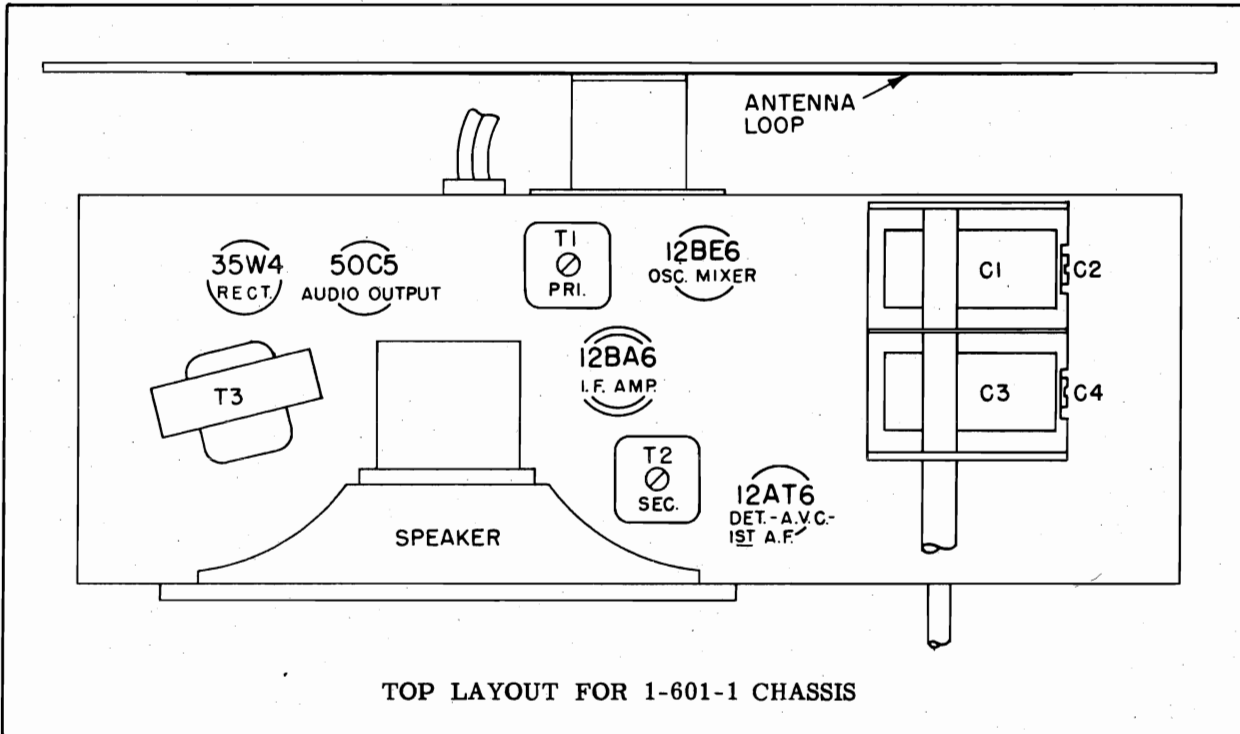

MODELS 511B, 511H, 511M,
512BR, 512CH, 512GR, 512RE,
512YE, Ch. 1-601-1

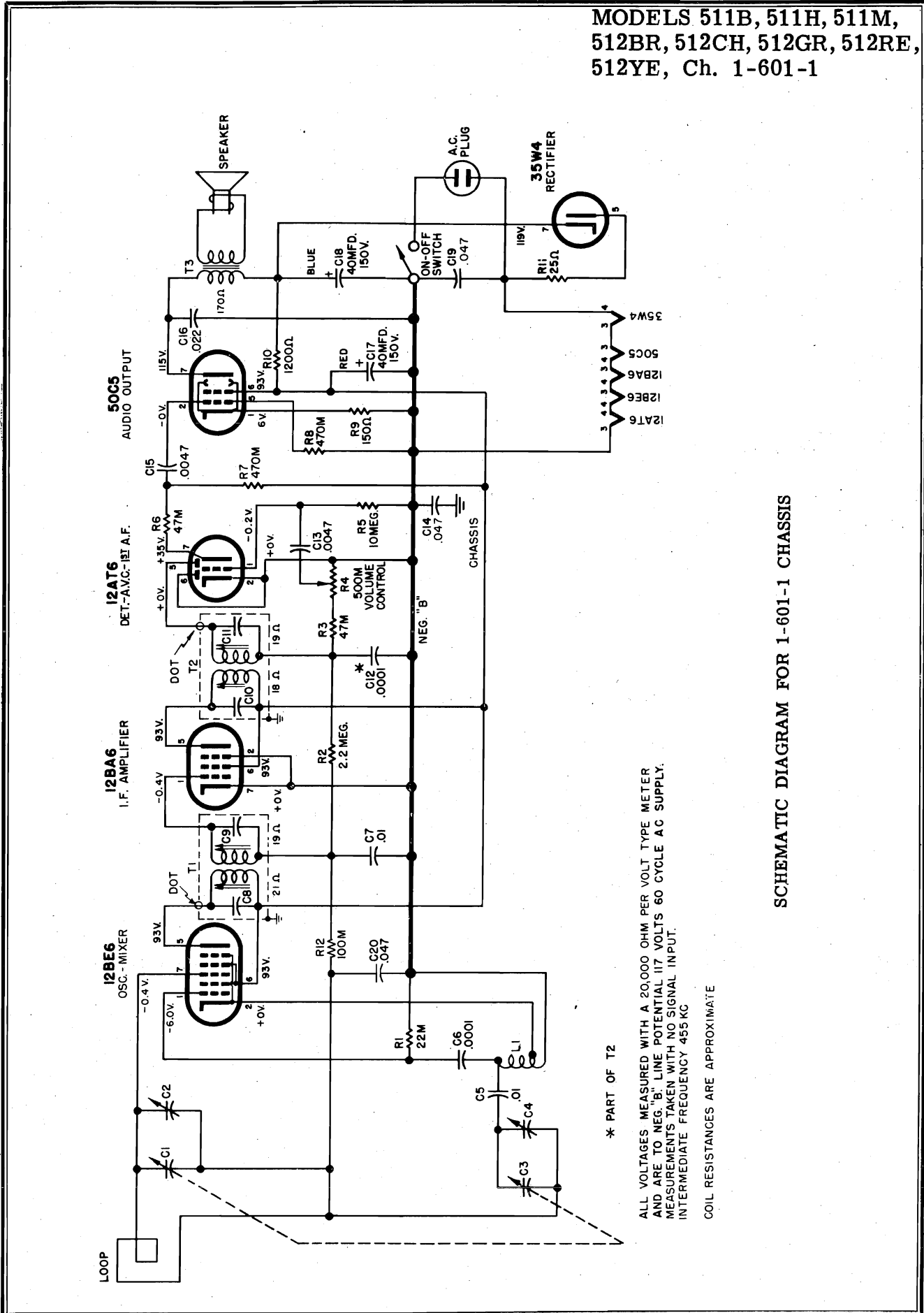

* PART OF T2

ALL VOLTAGES MEASURED WITH A 20,000 OHM PER VOLT TYPE METER
AND ARE TO NEG. "B" LINE POTENTIAL IIF VOLTS 60 CYCLE AC SUPPLY.
MEASUREMENTS TAKEN WITH NO SIGNAL INPUT.
INTERMEDIATE FREQUENCY 455 KC

COIL RESISTANCES ARE APPROXIMATE

SCHEMATIC DIAGRAM FOR 1-601-1 CHASSIS

MODELS 511B, 511H, 511M,
512BR, 512CH, 512GR, 512RE,
512YE, Ch. 1-601-1

REPAIR PARTS LIST

<u>SCHEMATIC LOCATION</u>	<u>SERVICE PART NUMBER</u>	<u>DESCRIPTION</u>
	582-0011	Antenna - Loop
	776-0004	Baffle - Speaker
	482-0002	Base - Miniature Tube Shield
	813-0007	Cabinet - Plastic - Black (511B)
	813-0017	Cabinet - Plastic - Brown (512BR)
	813-0019	Cabinet - Plastic - Chartreuse (512CH)
	813-0020	Cabinet - Plastic - Green (512GR)
	813-0022	Cabinet - Plastic - Ivory (511H)
	813-0009	Cabinet - Plastic - Mahogany (511M)
	813-0016	Cabinet - Plastic - Red (512RE)
	813-0018	Cabinet - Plastic - Yellow (512YE)
C6	166-0100P	Capacitor - Ceramic - .0001 Mfd. - 500 V.
C17	161-2002	Capacitor - Electrolytic - 40 Mfd. - 150 V.
C18		40 Mfd. - 150 V.
C13, C15	162-06247	Capacitor - Paper - .0047 Mfd. - 600 V.
C5, C7	162-0411M	Capacitor - Paper - .01 Mfd. - 400 V.
C16	162-04122	Capacitor - Paper - .022 Mfd. - 400 V.
C14, C19, C20	162-04147	Capacitor - Paper - .047 Mfd. - 400 V.
C1, C3	170-0006	Capacitor - Variable - 2 Gang
C2, C4		Trimmers (Part of 170-0006)
L1	487-0004	Clip - I. F. Transformer Mounting
R4	113-0015	Coil - Oscillator
	152-0012	Control - Volume with On-Off Switch
	195-0002	Cord - Line
	722-0019	Dial - Station Numerals (511B, 511M, 512BR, 512GR, 512RE)
	722-0021	Dial - Station Numerals (511H, 512CH, 512YE)
	740-0024	Knob - On-Off & Volume
R9	181-0151	Resistor - 150 Ohm - 1/2 W.
R1	181-0223	Resistor - 22,000 Ohm - 1/2 W.
R3, R6	181-0473	Resistor - 47,000 Ohm - 1/2 W.
R12	181-0104	Resistor - 100,000 Ohm - 1/2 W.
R7, R8	181-0474	Resistor - 470,000 Ohm - 1/2 W.
R2	181-0225	Resistor - 2.2 Megohm - 1/2 W.
R5	181-0106	Resistor - 10 Megohm - 1/2 W.
R11	189-0013	Resistor - 25 Ohm - 1 W. - W. W.
R10	182-0122	Resistor - 1,200 Ohm - 1 W.
	497-0005	Retainer & Bushing - Line Cord
	482-0003	Shield - Miniature Tube
	412-0015	Socket - 7 Prong - Miniature Tube
	539-0501	Speaker - 5" P. M.
T1	121-0013	Transformer - I. F. #1 (57-69301-1)
T2	122-0013	Transformer - I. F. #2 (57-69302-1) - Matched Pair
		or
T1	121-0016	Transformer - I. F. #1 (57-69303-1)
T2	122-0016	Transformer - I. F. #2 (57-69304-1) - Matched Pair
T3	143-0011	Transformer - Output
		Tube - 12AT6
		Tube - 12BA6
		Tube - 12BE6
		Tube - 35W4
		Tube - 50C5

MODELS 511B, 511H, 511M,
512BR, 512CH, 512GR, 512RE,
512YE, Ch. 1-601-1

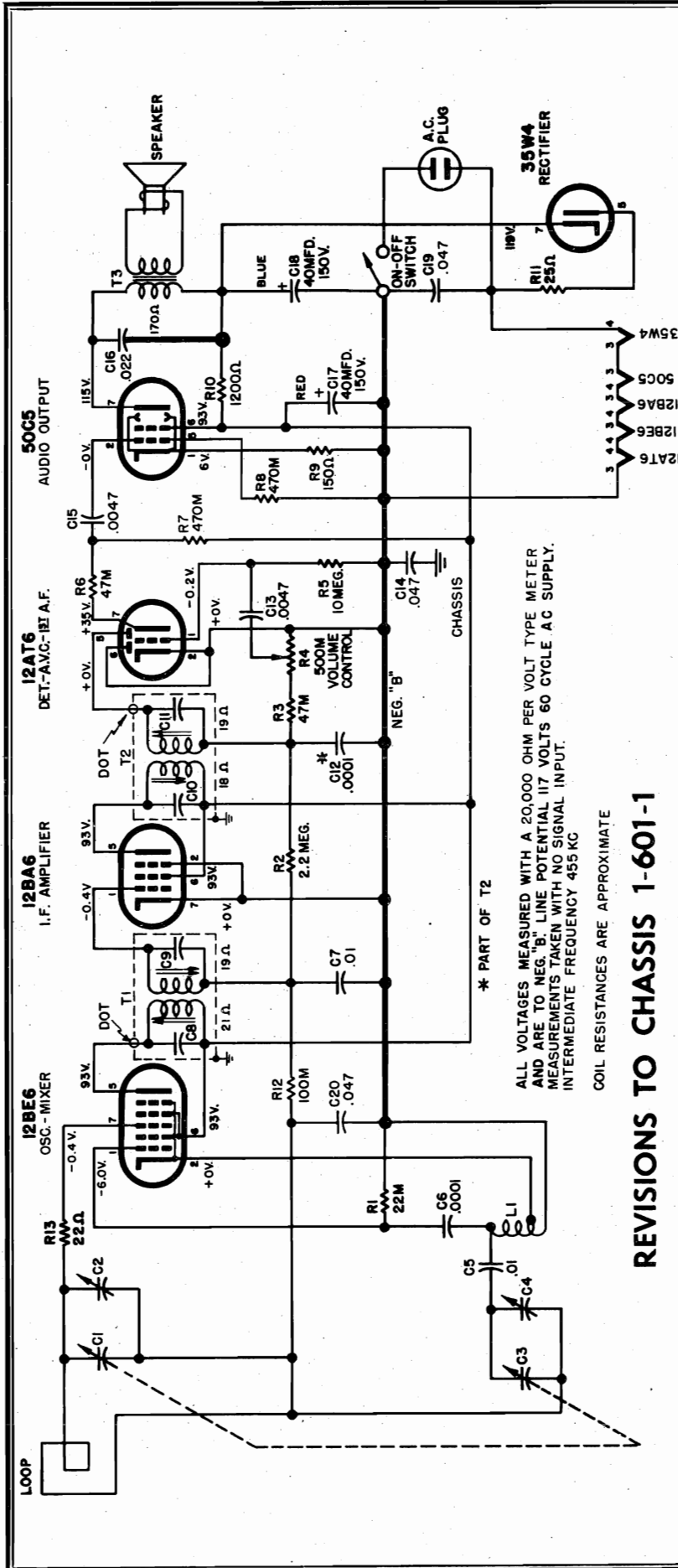

REVISIONS TO CHASSIS 1-601-1

The following changes are incorporated in chassis 1-601-1:

1. R13, 22 ohm resistor is added in series with the control grid (pin 7) of the 12BE6 Oscillator Mixer tube. This addition which reduces noise, applies to receivers with serial numbers 38,400 and up.
2. C16, the .022 Mfd. plate by-pass capacitor for the 50C5 Audio Output tube is now re-

turned to the cathode (pin 7) of the 35W4 Rectifier tube instead of to negative "B" as before. This revision reduces hum in the receiver. Models incorporating this change bear serial numbers 75,800 and up.

ALL VOLTAGES MEASURED WITH A 20,000 OHM PER VOLT TYPE METER AND ARE TO NEG. "B" LINE POTENTIAL 117 VOLTS 60 CYCLE AC SUPPLY. MEASUREMENTS TAKEN WITH NO SIGNAL INPUT. INTERMEDIATE FREQUENCY 455 KC

* COIL RESISTANCES ARE APPROXIMATE

* PART OF T2

SCHEMATIC LOCATION	SERVICE PART NUMBER	DESCRIPTION
R13	181-0220	Resistor - 22 Ohm - 1/2 W.
	ADD	

MODELS 541B, H, M,
542BR, CH, GR, RE,
YE, Ch. 1-602-1

GENERAL DESCRIPTION

The clock on each radio may be used to:

- (A) Provide accurate sweep second time.
- (B) Turn radio off automatically after retiring.
- (C) Turn radio program on for awakening.
- (D) Awaken to music with appliance operating.
- (E) Turn appliance on and off with radio on or off.

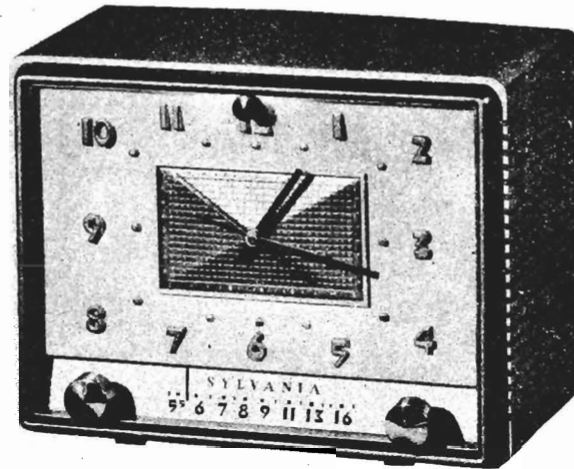

SPECIFICATIONS

POWER SUPPLY

105-125 Volts, 60 Cycle AC, 35 Watts

APPLIANCE OUTLET

Maximum Load 1100 Watts

FREQUENCY RANGE 540-1650 Kc.

INTERMEDIATE FREQUENCY 455 Kc.

LOUDSPEAKER ... 5" P. M. , 1. 47 Oz. Magnet

SYLVANIA TUBE COMPLEMENT

Function	Type
Oscillator-Mixer	12BE6
I. F. Amplifier	12BA6
Detector - A. V. C. - 1st A. F.	12AT6
Output	50C5
Rectifier	35W4

CABINET DIMENSIONS (inches)

Width 10. 2, Height 7. 8, Depth 6. 3

ALIGNMENT PROCEDURE

PRELIMINARY INSTRUCTIONS

Take chassis from cabinet as in step C page 8.

Insert temporary jumper between closely spaced pins of clock socket.

Allow chassis and signal generator several minutes warm-up.

Connect an AC Voltmeter across voice coil terminals and set volume control to full volume position.

Keep generator output at lowest useable level to prevent AVC action from interfering with accurate alignment.

I. F. ALIGNMENT

1. Set the variable tuning capacitor to a point near 1,000 Kc. where no signals are heard.
2. Tune amplitude modulated signal generator to 455 Kc. Connect generator output to Negative "B" and through a 0. 1 Mfd. capa-

tor to control grid (pin 7) of the 12BE6 Oscillator-Mixer tube.

3. Align I.F. transformers T1 and T2 by adjusting first the cores accessible from under the chassis, then the top cores. Repeat this operation until a maximum meter reading is obtained.

R. F. ALIGNMENT

1. Turn tuning shaft clockwise to minimum capacity setting of the variable capacitor.
2. Tune generator, connected as described above, to 1650 Kc.
3. Adjust oscillator trimmer C4 for maximum output.
4. Connect generator to a Hazeltine loop to radiate a 1450 Kc. signal into the receiver.
5. Tune the receiver to 1450 Kc.
6. Adjust antenna trimmer C2 to obtain maximum output.

MODELS 541B, H, M,
542BR, CH, GR, RE,
YE, Ch. 1-602-1

Remove the jumper from the closely spaced pins on the clock socket and replace the clock plug. Reinstall the receiver chassis in the cabinet.

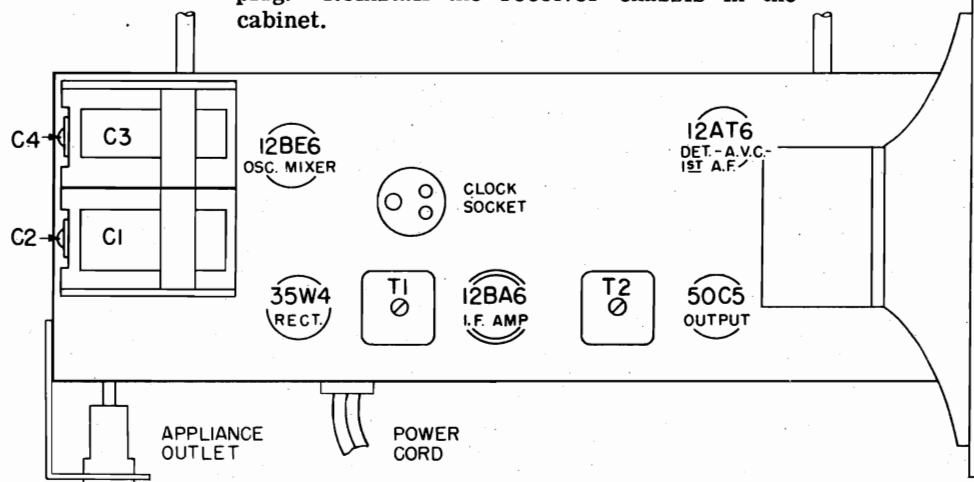

TOP LAYOUT FOR 1-602-1 CHASSIS

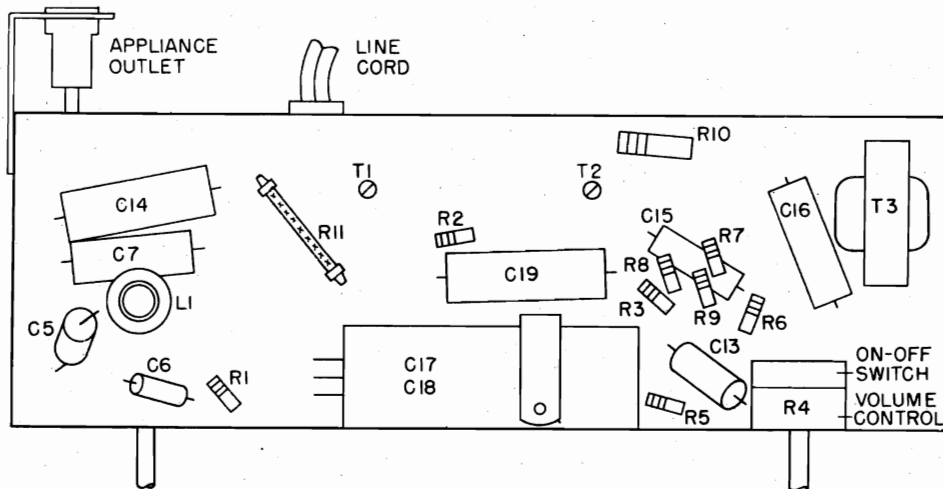

BOTTOM LAYOUT FOR 1-602-1 CHASSIS

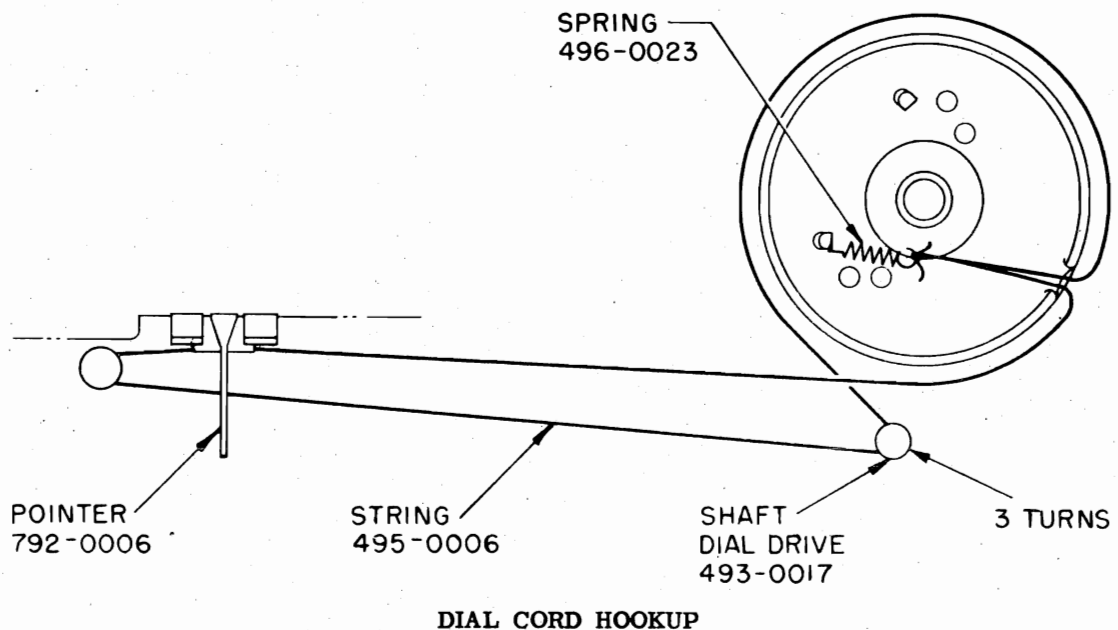

DIAL CORD HOOKUP

MODELS 541B, H, M,
542BR, CH, GR, RE,
YE, Ch. 1-602-1

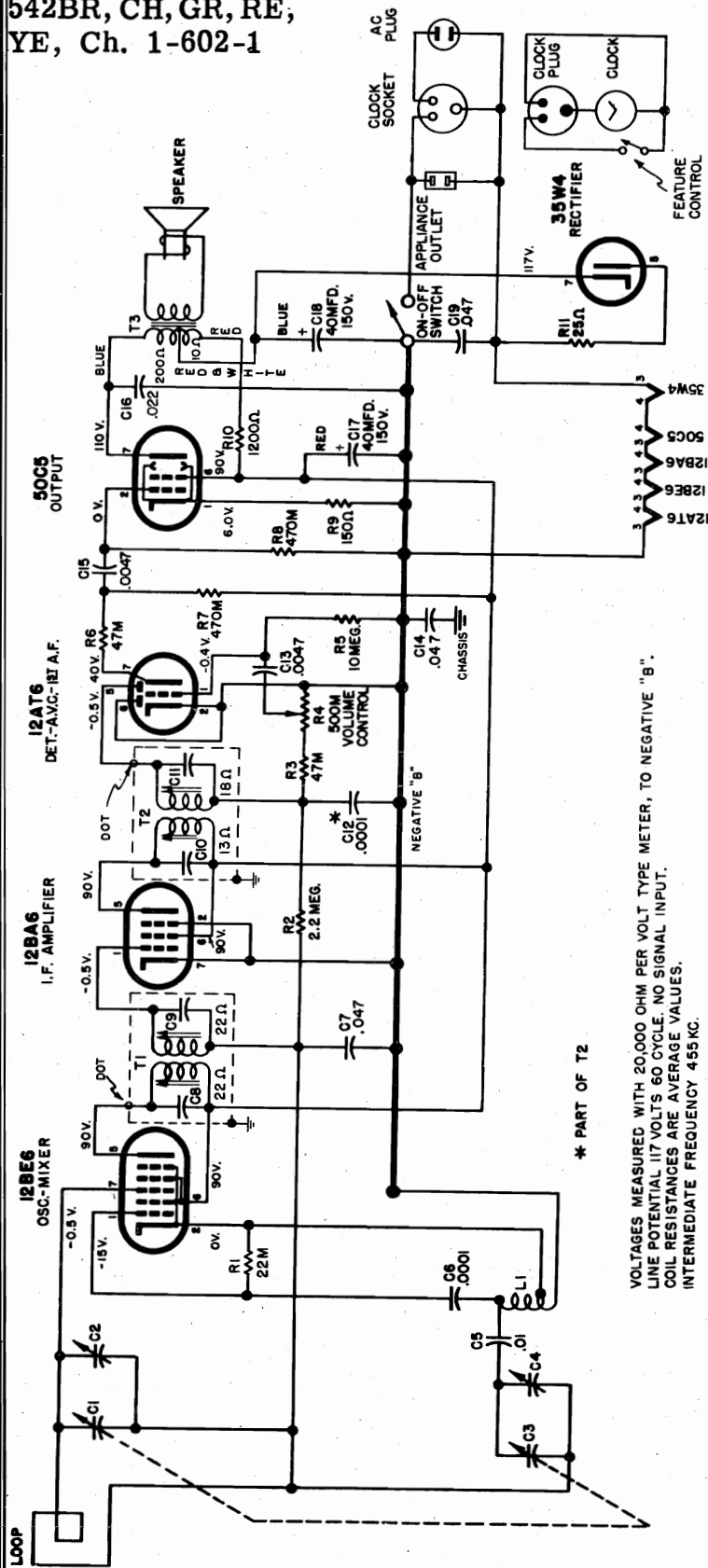

TO REMOVE CLOCK FROM THE CABINET

- A. Remove line cord from power socket.
 - B. Set the clock hands to 2 hours, 10 minutes, 10 seconds - (i.e. all hands toward the upper right hand corner of the rectangular gold plate).
 - C. Remove chassis from cabinet as follows:
 - D. Unscrew Feature Control knob.
 - E. **VERY CAREFULLY** remove the four clock holding speed nuts from the plastic bosses.
 - F. Remove clock.
- To replace clock make sure the hands are set as in Step B and reverse the above procedure.

REPAIR PARTS LIST

<u>SCHEMATIC LOCATION</u>	<u>SERVICE PART NUMBER</u>	<u>DESCRIPTION</u>
	582-0013	Antenna - Loop
	482-0002	Base - Miniature Tube Shield
	813-0008	Cabinet - Plastic - Black (541B)
	813-0012	Cabinet - Plastic - Brown (542BR)
	813-0014	Cabinet - Plastic - Chartreuse (542CH)
	813-0013	Cabinet - Plastic - Green (542GR)
	813-0021	Cabinet - Plastic - Ivory (541H)
	813-0010	Cabinet - Plastic - Mahogany (541M)
	813-0011	Cabinet - Plastic - Red (542RE)
	813-0015	Cabinet - Plastic - Yellow (542YE)
C6	166-0100P	Capacitor - Ceramic - .0001 Mfd. - 500 V.
C17	161-2002	Capacitor - Electrolytic - 40 Mfd. - 150 V.
C18		40 Mfd. - 150 V.
C13, C15	162-06247	Capacitor - Paper - .0047 Mfd. - 600 V.
C5	162-0411M	Capacitor - Paper - .01 Mfd. - 400 V.
C16	162-04122	Capacitor - Paper - .022 Mfd. - 400 V.
C7, C14, C19	162-04147	Capacitor - Paper - .047 Mfd. - 400 V.
C1, C3	170-0007	Capacitor - Variable - 2 Gang
C2, C4		Trimmers (Part of 170-0007)
	487-0004	Clip - I. F. Transformer Mounting
L1	113-0015	Coil - Oscillator
R4	152-0013	Control - Volume & On-Off
	195-0002	Cord - Line
	715-0008	Cover - Front
	723-0003	Dial - Station Numerals
	749-0013	Knob - Feature Control
	740-0021	Knob - Tuning - Volume & On-Off
	552-5226	Nut - Speed Tuning Shaft
	552-0031	Nut - Speed - Clock Mounting
	792-0006	Pointer - Dial
	494-0007	Pully - Dial Drive
R9	181-0151	Resistor - 150 Ohm - 1/2 W.
R1	181-0223	Resistor - 22,000 Ohm - 1/2 W.
R3, R6	181-0473	Resistor - 47,000 Ohm - 1/2 W.
R7, R8	181-0474	Resistor - 470,000 Ohm - 1/2 W.
R2	181-0225	Resistor - 2.2 Megohm - 1/2 W.
R5	181-0106	Resistor - 10 Megohm - 1/2 W.
R11	189-0013	Resistor - 25 Ohm - 1 W. - W. W.
R10	182-0122	Resistor - 1,200 Ohm - 1 W.
	497-0005	Retainer & Bushing - Line Cord
	493-0017	Shaft - Tuning
	482-0003	Shield - Miniature Tube
	481-0014	Sleeve - Shaft Bearing
	419-0005	Socket - 2 Prong - Appliance
	419-0004	Socket - 3 Prong - Clock
	412-0015	Socket - 7 Prong - Miniature
	539-0501	Speaker - 5" P. M.
	496-0023	Spring - String Drive
	495-0006	String - Drive (Specify desired length when ordering)
T1	121-0016	Transformer - I. F. #1
T2	122-0018	Transformer - I. F. #2
T3	143-0019	Transformer - Output
		Tube - 12AT6
		Tube - 12BA6
		Tube - 12BE6
		Tube - 35W4
		Tube - 50C5

MODELS 541B, H, M,
542BR, CH, GR, RE,
YE, Ch. 1-602-1

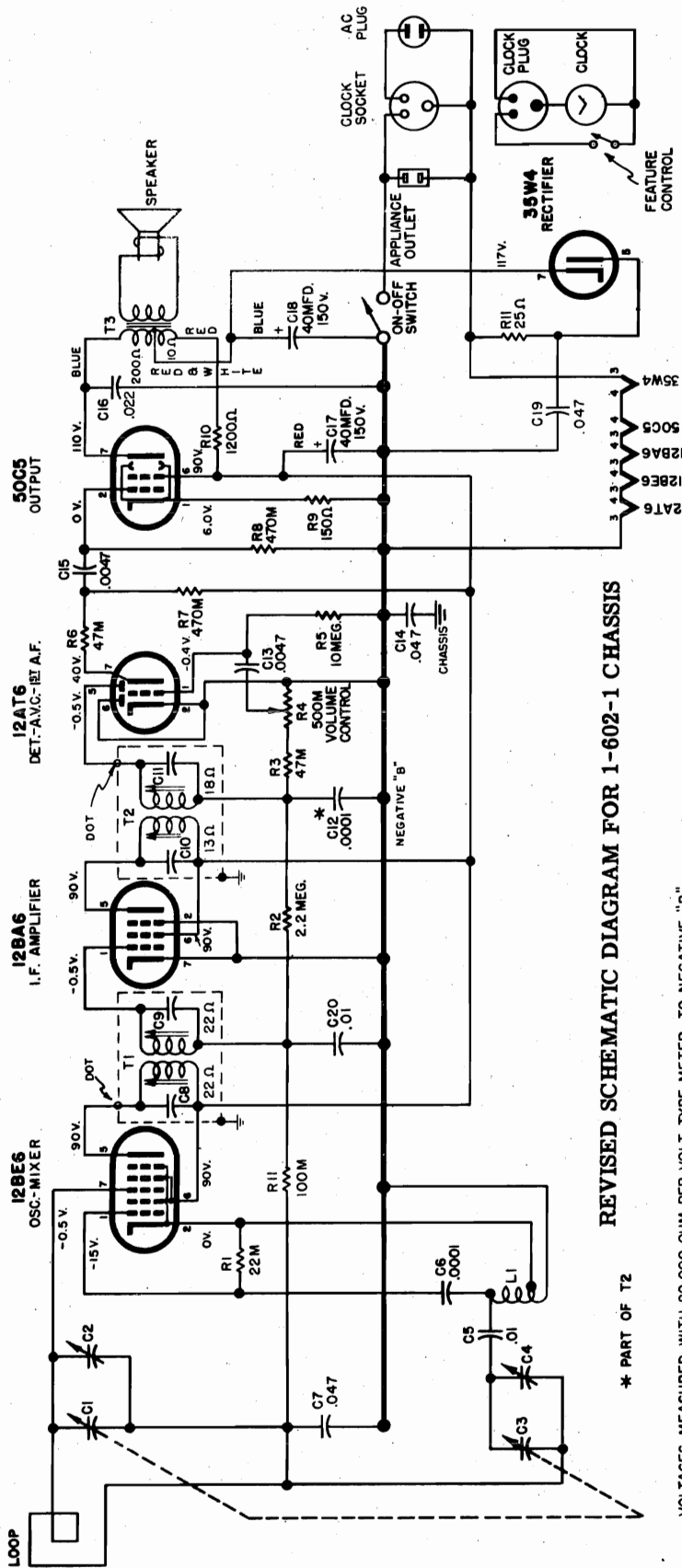

REVISED SCHEMATIC DIAGRAM FOR 1-602-1 CHASSIS

* PART OF T2

VOLTAGES MEASURED WITH 20,000 OHM PER VOLT TYPE METER, TO NEGATIVE "B".
LINE POTENTIAL 117 VOLTS 60 CYCLE. NO SIGNAL INPUT.
COIL RESISTANCES ARE AVERAGE VALUES.
INTERMEDIATE FREQUENCY 455 KC.

sis models is held in the cabinet by four "D" shaped bosses molded on the inside of the cabinet front. Over each boss is assembled a speed nut which fastens the unit in place. With the cabinet in its normal position, the speed nuts occupy a horizontal position. If the speed nuts are rotated to a vertical position, using a pair of pliers, they can be lifted from the bosses with only finger pressure.

To replace a speed nut, set it over the boss in a horizontal position and use a pair of long nose pliers to apply pressure to the two webs on either side of the diamond shaped cutout.

<u>SCHEMATIC LOCATION</u>	<u>SERVICE PART NUMBER</u>	<u>DESCRIPTION</u>
	<u>Add</u>	
C20	162-0411M	Capacitor - Paper - .01 Mfd. - 400 V.
R11	181-0104	Resistor - 100,000 Ohm - 1/2 W.

Underwriters' Change in 1-602-1 Radio Chassis

Removal of Clock Holding Speed Nuts

The clock movement used with 1-602-1 chassis

9-22/51

SPECIFICATIONS

Power Supply
 AC/DC Operation 117 V. DC or AC 15 Watts
 Battery Operation 7.5V. "A", 75V. or 90V. "B"
 Frequency Range . . . 540 KC to 1650 KC
 Intermediate Frequency 455 KC
 Speaker 4" x 6" P.M.

TUBE COMPLEMENT

V1 Oscillator/Mixer 1R5
 V2 IF Amplifier 1U4
 V3 Detector, AVC, 1st AF 1U5
 V4 Audio Output 3V4

ALIGNMENT PROCEDURE

PRELIMINARY INSTRUCTIONS

1. Remove chassis from cabinet.
2. Allow chassis and signal generator several minutes warm up.
3. Keep generator output at lowest usable level to prevent AVC action from interfering with accurate alignment.
4. Connect AC voltmeter across voice coil.
5. Adjust volume control to full volume.

STEP	SIGNAL GENERATOR Frequency	Connection	RADIO DIAL SETTING	ADJUST	COMMENTS
1.	455 KC	Thru .01 Mfd. to pin 6 of 1R5.	Tuning cap. plates fully open.	T2 D T2 C T1 B T1 A	Connect ground lead of signal generator to negative "B" in receiver. Adjust T1 and T2 (IF transformers) for <u>maximum output</u> .
2.	1650 KC	Radiated to receiver thru a loop of several turns.	Tuning cap. plates fully open	C4 trimmer	Adjust C4 (high-end oscillator trimmer) for <u>maximum output</u> . Set variable tuning capacitor to minimum capacity.
3.	1400 KC to 1500 KC	Same as 2.	1400 KC to 1500 KC	C1 trimmer	Adjust C1 (antenna trimmer) for <u>maximum output</u> .
4.	600 KC	Same as 2.	Approx. 600 KC	L2 core	Adjust L2 (low-end oscillator adjustment) for <u>maximum output</u> while simultaneously "rocking" variable tuning capacitor.
5.	Repeat step 3.				

CHASSIS REMOVAL

1. Remove control knobs, station selector pointer and base. Remove station selector pointer by gripping it with either a bent wire hook or needle nose pliers inserted in the center slots.
2. Remove the four screws securing chassis and dial caps to the cabinet. Note assembly of the handle and dials, and that chassis slides through grooves in cabinet. The chassis may now be removed.
3. To facilitate calibration, turn volume control until it clicks "Off" and Station Selector until tuning capacitor is fully meshed. Line up indicator marks accordingly, and press on knobs.

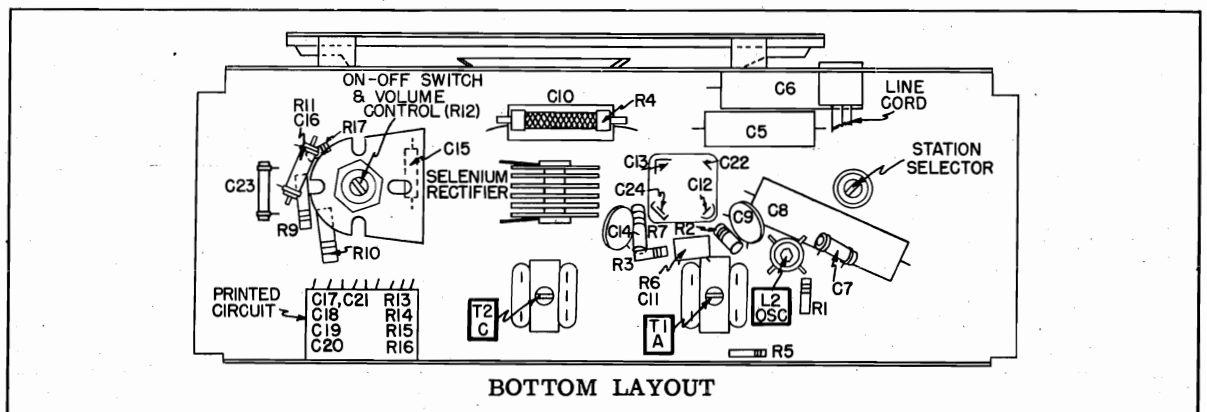

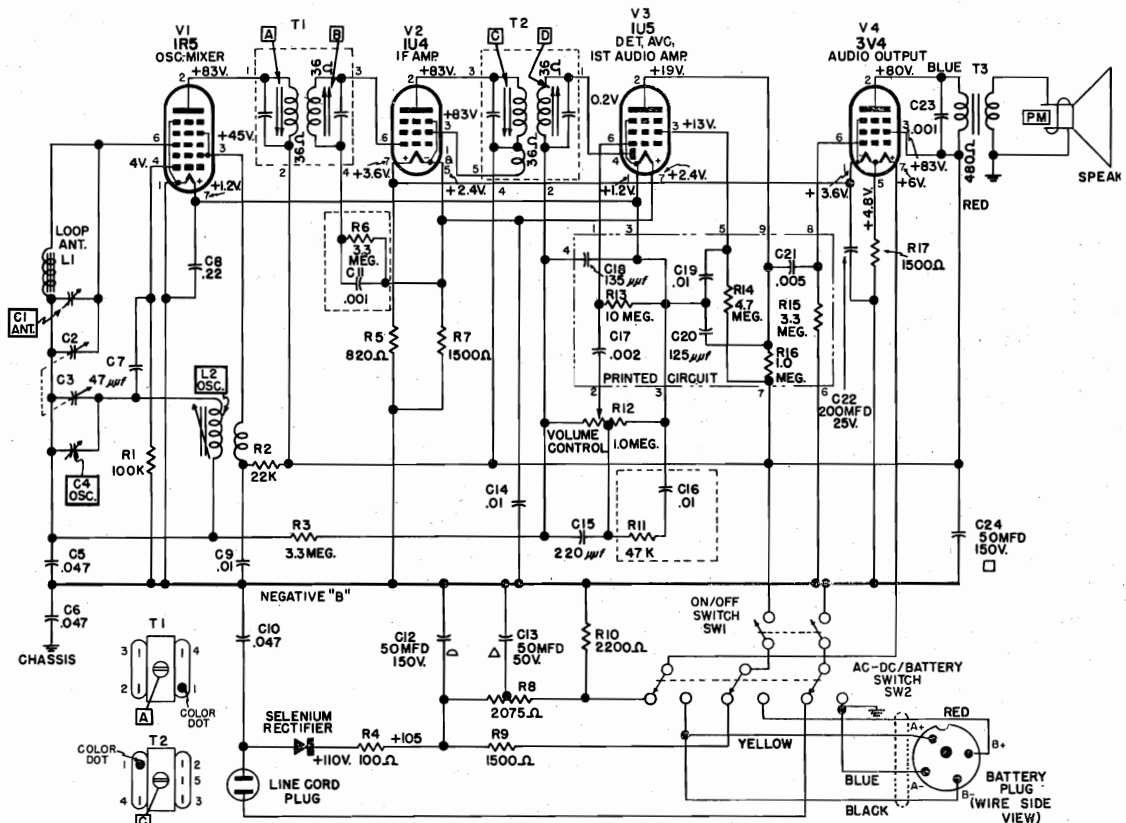

- NOTES:
1. VOLTAGES MEASURED WITH 20,000 OHM/VOLT METER TO NEGATIVE "B"; SWITCH SW2 SET TO AC/DC POSITION, LINE VOLTAGE 117 V. AC, NO SIGNAL INPUT.
 2. COIL RESISTANCES ARE AVERAGE VALUES. INTERMEDIATE FREQUENCY 455 K.C.
 3. BATTERY—EVEREADY NO. 755 "AB" PACK OR EQUIVALENT SUPPLYING 7.5 V. "A" AND 75 V. "B". (NO. 756 "AB" PACK OR EQUIVALENT SUPPLYING 7.5 V. "A" AND 90 V. "B" IS OPTIONAL.)
 4. VOLTAGES OR RESISTANCES NOT SHOWN WHERE TOO SMALL OR WIDELY VARIABLE.

SCHMATIC DIAGRAM FOR 1-604-1 CHASSIS

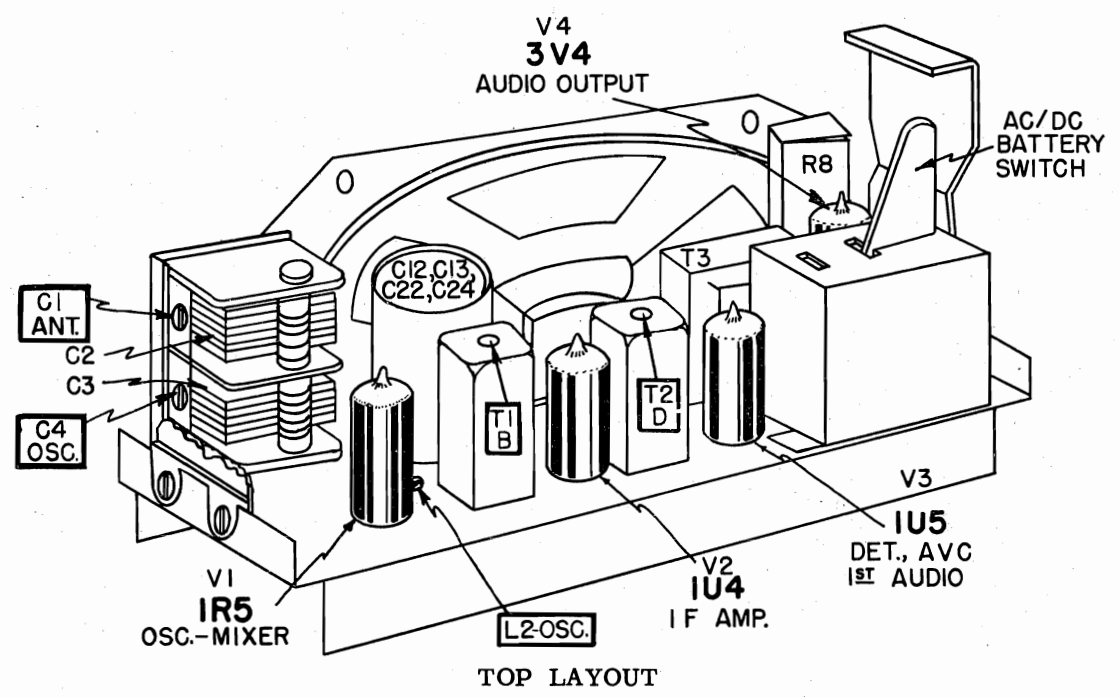

TOP LAYOUT

SCHMATIC LOCATION	SERVICE PART NUMBER	DESCRIPTION	SCHMATIC LOCATION	SERVICE PART NUMBER	DESCRIPTION
CAPACITORS					
C1	170-0011	Trimmer (Part of C2)	C11	190-0011	Capacitor/Resistor Combination
C2	170-0011	Variable - 2 Gang (Antenna Section)	R6		.001 Mfd. - 500 V.
C3	160-02147	Variable - 2 Gang (Oscillator Section)			3.3 Megohm - 1/2 W.
C4	160-04147	Trimmer (Part of C3)	C16	190-0006	Capacitor/Resistor Combination
C5	166-0047N	.047 Mfd. - 200 V. - Paper - Molded	R11		.01 Mfd. - 500 V.
C6	160-02022	47 Mmfd. - 500 V. - Ceramic	R12		47,000 Ohm - 1/2 W.
C7	168-0002D	.22 Mfd. - 100 V. - Paper - Molded			Control - On/Off and Volume
C8	160-04147	.01 Mfd. - 500 V. - Ceramic			Cord - Line
C9	161-4008	.047 Mfd. - 400 V. - Paper - Molded	C17		Printed Circuit - Detector/Audio Plate
C10	161-4008	Listed under "Miscellaneous Electrical Parts"	C18		.002 Mfd. - 500 V.
C11	161-4008	50 Mfd. - 150 V. - Electrolytic	C19		135 Mmfd. - 500 V.
C12	161-4008	50 Mfd. - 50 V. - Electrolytic	C20		.01 Mfd. - 500 V.
C13	168-0002D	.01 Mfd. - 500 V. - Ceramic	C21		125 Mmfd. - 500 V.
C14	163-0220	220 Mmfd. - 500 V. - Mica	R13		.005 Mfd. - 500 V.
C15		Listed under "Miscellaneous Electrical Parts"	R14		10 Megohm - 1/2 W.
C16, C17, C18			R15		4.7 Megohm - 1/2 W.
C19, C20, C21			R16		3.3 Megohm - 1/2 W.
C22	161-1000P	200 Mfd. - 25 V. - Electrolytic			1 Megohm - 1/2 W.
C23	161-4008	.001 Mfd. - 500 V. - Ceramic			Rectifier - Selenium
C24		50 Mfd. - 150 V. - Electrolytic			Speaker - 4" x 6" P.M.
					Switch (AC-DC/Battery)
CHOKES, COILS, AND TRANSFORMERS					
L1	582-0016	Loop Antenna (includes mounting board)			
L2	113-0025	Oscillator Coil			
T1	121-0022	1st IF Transformer			
T2	122-0024	2nd IF Transformer			
T3	143-0027	Audio Output Transformer			
MISCELLANEOUS CABINET PARTS					
	803-0012	Bar - Handle Frame			
	813-0033	Cabinet - Plastic - Black (Model 433B)			
	813-0035	Cabinet - Plastic - Green (Model 433GR)			
	813-0034	Cabinet - Plastic - Ivory (Model 433H)			
	813-0036	Cabinet - Plastic - Luggage (Model 433LU)			
	813-0038	Cabinet - Plastic - Red (Model 433RE)			
	813-0037	Cabinet - Plastic - Yellow (Model 433 YE)			
	818-0012	Cap - Handle - Plastic (Model 433B)			
	818-0013	Cap - Handle - Plastic (Model 433H)			
	818-0014	Cap - Handle - Plastic (Model 433GR)			
	818-0015	Cap - Handle - Plastic (Model 433LU)			
	818-0017	Cap - Handle - Plastic (Model 433RE)			
	818-0016	Cap - Handle - Plastic (Model 433YE)			
	808-0013	Cover - Base			
	723-0006	Dial - On/Off and Volume			
	723-0005	Dial - Station Selector			
	740-0043	Knob - On/Off and Volume			
	740-0044	Knob - Station Selector			
	818-0018	Nameplate - Sylvania			
	792-0014	Pointer - Station Selector			
	554-0015	Ring - Base Cover Retaining			
MISCELLANEOUS ELECTRICAL PARTS					
	473-0004	Arm - AC-DC/Battery Switch Actuating			
	487-0004	Clip - IF Transformer Mounting			
	476-0002	Insulator - Electrolytic Capacitor Mounting			
	412-0015	Socket - 7 Prong - Miniature			
MISCELLANEOUS ELECTRICAL PARTS					
	190-0011	Capacitor/Resistor Combination			
	190-0006	Capacitor/Resistor Combination			
	152-0020	Control - On/Off and Volume			
	195-0002	Cord - Line			
	190-0010	Printed Circuit - Detector/Audio Plate			
	517-0005	Rectifier - Selenium			
	539-0402	Speaker - 4" x 6" P.M.			
	572-0003	Switch (AC-DC/Battery)			
RESISTORS					
	181-0104	100,000 Ohm - 1/2 W.			
	181-0223	22,000 Ohm - 1/2 W.			
	181-0335	3.3 Megohm - 1/2 W.			
	189-0033	100 Ohm - 2 W. - W.W.			
	181-0821	820 Ohm - 1/2 W.			
	181-0152	Listed under "Miscellaneous Electrical Parts"			
	185-0004	1,500 Ohm - 1/2 W.			
	182-0152	2,150 Ohm - 6W. - W.W.			
	182-0222	1,500 Ohm - 1W.			
	181-0152	2,200 Ohm - 1W.			
	181-0152	Listed under "Miscellaneous Electrical Parts"			
	1,500 Ohm - 1/2W.				
TUBE COMPLEMENT					
V1	1R5	Oscillator/Mixer			
V2	1U4	IF Amplifier			
V3	1U5	Detector, AVC, 1st Audio Amplifier			
V4	3V4	Audio Output			

MODELS 513, 563, Ch.
1-601-2, 1-601-3

SPECIFICATIONS

Power Supply 105-128 Volts
25 to 60 Cycle AC or DC, 35 Watts
Frequency Range 540 KC to 1650 KC
Intermediate Frequency 455 KC
Loudspeaker 5" P.M.

TUBE COMPLEMENT

V1 Oscillator/Mixer 12BE6
V2 IF Amplifier 12BA6
V3 Detector, AVC, 1st AF 12AT6
V4 Audio Output 50C5
V5 Rectifier 35W4

ALIGNMENT PROCEDURE

PRELIMINARY INSTRUCTIONS

1. Remove chassis from cabinet.
2. Allow chassis and signal generator several minutes warm up.
3. Keep generator output at lowest usable level to prevent AVC action from interfering with accurate alignment.
4. Connect AC voltmeter across voice coil.
5. Adjust volume control to full volume.

STEP	SIGNAL GENERATOR Frequency	Connection	RADIO DIAL SETTING	ADJUST	COMMENTS
1.	455 KC	Thru 0.1 Mfd. to pin 7 of 12BE6.	1000 KC (Approx.)	T2 D T2 C T1 B T1 A	Connect ground lead of signal generator to negative "B" in receiver. Set radio dial to approximately 1000 KC where no signals are audible. Adjust T1 and T2 (IF transformers) for <u>maximum output</u> .
2.	1650 KC	Radiated to receiver thru a loop of several turns.	Tuning Cap. plates fully open	C4 trimmer	Adjust C4 (oscillator trimmer) for <u>maximum output</u> . Set variable tuning capacitor to minimum capacity.
3.	1400 KC to 1500 KC	Same as 2.	1400 KC to 1500 KC	C2 trimmer	Adjust C2 (antenna trimmer) for <u>maximum output</u> .
4.	600 KC	Same as 2	600 KC (Approx.)	L2 core	Adjust L2 (low-end oscillator adjustment) for maximum output while simultaneously "rocking" variable tuning capacitor.
5.	Repeat step 3.				

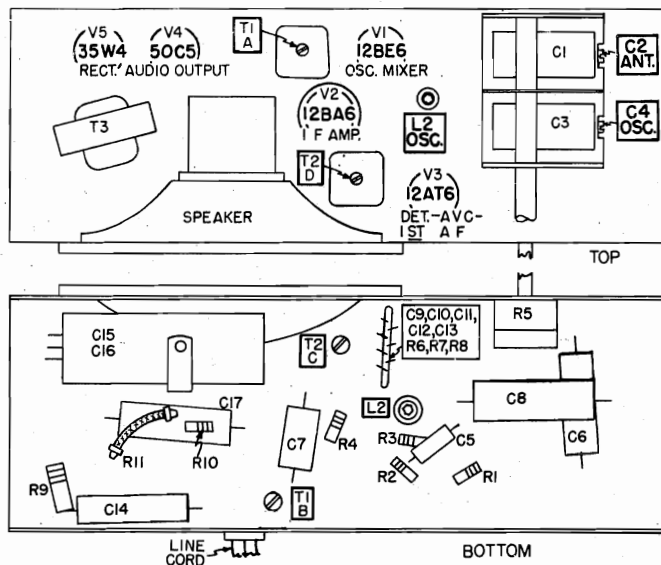

BOTTOM AND TOP LAYOUTS

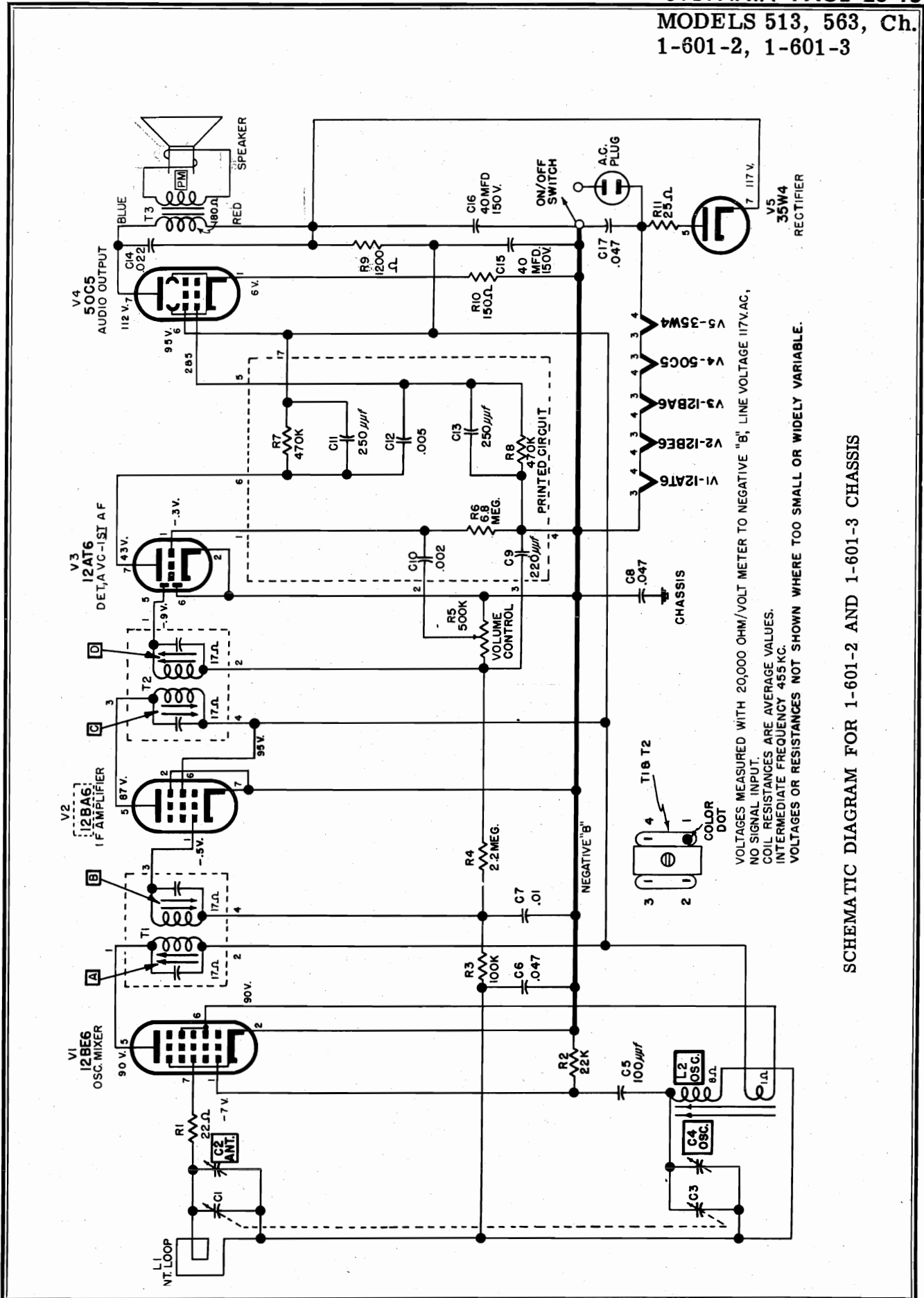

SCHEMATIC DIAGRAM FOR 1-601-2 AND 1-601-3 CHASSIS

MODELS 513, 563, Ch.
1-601-2, 1-601-3

REPAIR PARTS LIST

SCHEMATIC LOCATION	SERVICE PART NUMBER	DESCRIPTION
	<u>CAPACITORS</u>	
C1	170-0006	Variable - 2 Gang (Antenna Section) (513 Models)
C1	170-0010	Variable - 2 Gang (Antenna Section) (Model 563B only)
C2		Trimmer (Part of C1)
C3	170-0006	Variable - 2 Gang (Oscillator Section) (513 Models)
C3	170-0010	Variable - 2 Gang (Oscillator Section) (Model 563B only)
C4		Trimmer (Part of C3)
C5	166-0100P	.0001 Mfd. - 500 V. - Ceramic
C6	160-02147	.047 Mfd. - 200 V. - Paper
C7	162-0411M	.01 Mfd. - 400 V. - Paper
C8	160-04147	.047 Mfd. - 400 V. - Paper
C9, C10, C11		Listed under "Miscellaneous Electrical Parts"
C12, C13		.022 Mfd. - 500 V. - Paper
C14		40 Mfd. - 150 V. - Electrolytic
C15		40 Mfd. - 150 V. - Electrolytic
C16		.047 Mfd. - 400 V. - Paper
C17		.047 Mfd. - 400 V. - Paper
	<u>CHOKES, COILS, AND TRANSFORMERS</u>	
L1	582-0011	Loop Antenna (513 Models)
L1	581-0002	Loop Antenna (Model 563B only)
L2	113-0026	Oscillator Coil
T1	121-0013	1st IF Transformer (57-69301-1) - Matched Pair
T2	122-0013	2nd IF Transformer (57-78799-1)
T1	121-0016	1st IF Transformer (57-69303-1) - Matched Pair
T2	122-0016	2nd IF Transformer (57-78798-1)
T3	143-0011	Audio Output Transformer
	<u>MISCELLANEOUS CABINET PARTS</u>	
776-0004		Baffle - Speaker
813-0026		Cabinet - Plastic - Black (Model 563B)
813-0007		Cabinet - Plastic - Black (Model 513B)
813-0019		Cabinet - Plastic - Chartreuse (Model 513CH)
813-0020		Cabinet - Plastic - Green (Model 513GR)
813-0022		Cabinet - Plastic - Ivory (Model 513H)
813-0009		Cabinet - Plastic - Mahogany (Model 513M)
813-0025		Cabinet - Plastic - Red (Model 513RE)
813-0018		Cabinet - Plastic - Yellow (Model 513YE)
722-0031		Dial - Station (513 Models)
722-0019		Dial - Station (Model 563B only)
487-0018		Fastener - Snap (Loop antenna mounting)
740-0037		Knob - On/Off Switch (513 Models)
740-0005		Knob - On/Off Switch (Model 563B only)
	<u>MISCELLANEOUS ELECTRICAL PARTS</u>	
R5	152-0023	Control - Volume with On/Off Switch (513 Models)
R5	152-0004	Control - Volume with On/Off Switch (Model 563 only)
	195-0002	Cord - Line
	190-0009	Printed Circuit - Detector/Audio Plate
C9		220 Mmfd. - 500 V.
C10		.002 Mfd. - 500 V.
C11		250 Mmfd. - 500 V.
C12		.005 Mfd. - 500 V.
C13		250 Mmfd. - 500 V.
R6		6.8 Megohm - 1/2 W.
R7		470,000 Ohm - 1/2 W.
R8		470,000 Ohm - 1/2 W.
	539-0501	Speaker - 5" P. M.
	<u>RESISTORS</u>	
R1	181-0220	22 Ohm - 1/2 W.
R2	181-0223	22,000 Ohm - 1/2 W.
R3	181-0104	100,000 Ohm - 1/2 W.
R4	181-0225	2.2 Megohm - 1/2 W.
R5, R6, R7, R8		Listed under "Miscellaneous Electrical Parts"
R9	182-0122	1,200 Ohm - 1 W.
R10	181-0151	150 Ohm - 1/2 W.
R11	189-0013	25 Ohm - 1 W. - W. W.
	<u>TUBE COMPLEMENT</u>	
V1		12BE6 - Oscillator/Mixer
V2		12BA6 - IF Amplifier
V3		12AT6 - Detector, AVC, 1st Audio Amplifier
V4		50C5 - Audio Output
V5		35W4 - Rectifier

MODELS 543, 593, Ch.
1-602-2, 1-602-3

SPECIFICATIONS

Frequency Range 540 KC to 1650 KC
 IF Frequency 455 KC
 Power Supply 105 to 128 Volts
 60 Cycle AC, 35 Watts
 Appliance Outlet . . Maximum Load 1100Watts
 Loudspeaker 5" P.M.

TUBE COMPLEMENT

V1 Oscillator/Mixer 12BE6
 V2 IF Amplifier 12BA6
 V3 Detector, AVC, 1st AF Amplifier 12AT6
 V4 Audio Output 50C5
 V5 Rectifier 35W4

ALIGNMENT PROCEDURE

PRELIMINARY INSTRUCTIONS

1. Remove chassis from cabinet as in step C, under "Chassis Removal."
2. Insert temporary jumper between pins 4 and 5 on clock socket to complete AC circuit.
3. Allow chassis and signal generator several minutes warm-up.
4. Keep generator output at lowest usable level to prevent AVC action from interfering with accurate alignment.
5. Connect AC voltmeter across voice coil and set volume control to full volume.

STEP	SIGNAL GENERATOR		RADIO DIAL SETTING	ADJUST	COMMENTS
	Frequency	Connection			
1.	455 KC	Thru .01 Mfd. to pin 7 of 12BE6	Extreme right hand side	T1 (Both cores) T2 (Both cores)	Connect ground lead of signal generator to negative "B" in receiver. Adjust T1 and T2 (IF transformers) for <u>maximum output</u> .
2.	1650 KC	Radiated to receiver thru a loop of several turns	Extreme right hand side	C5 trimmer	Set variable tuning capacitor to minimum capacity. Adjust C4 (high-end oscillator trimmer) for <u>maximum output</u> .
3.	1400 KC to 1500 KC	Same as 2.	1400 KC to 1500 KC	C2 trimmer	Adjust C2 (antenna trimmer) for <u>maximum output</u>
4.	600 KC	Same as 2.	Approx. 600 KC	L2 Core	Adjust L2 (low-end oscillator adjustment) for <u>maximum output</u> while simultaneously "rocking" variable tuning capacitor.
5.	Repeat step 3. Then remove clock socket jumper.				

REMOVAL OF CHASSIS AND TIMER MOVEMENT

- A. Remove line cord from power socket.
- B. Set all clock hands toward upper right hand corner of clock face.
- C. Remove chassis from cabinet as follows:
 1. Remove volume control and tuning control knobs.
 2. Remove the two upper clips on back cover.
 3. Remove three chassis mounting screws from the underside of cabinet.
 4. Pull chassis part way out of cabinet and disconnect four-prong clock plug.
 5. Remove chassis completely.
- D. Remove clock from cabinet as follows:
 1. Remove two upper clock mounting screws.
 2. Loosen two lower clock mounting screws and lift clock assembly up and out from the cabinet.

NOTE: The panelescent clock face (on 543 models only) is an integral part of clock assembly. When replacement of panelescent unit becomes necessary, position all clock hands at either 12 o'clock or 6 o'clock. Remove clock hands with care to avoid bending them or enlarging mounting holes in hands. When installing, locate hands at same position as before removal.

SERVICING OF SESSIONS MOVEMENT

The Sessions clock-timer unit is warranted under normal use and service against defects in workmanship and material for a period of one year from date the timer is sold by Sessions. Sessions agrees to repair or replace without charge any part or parts proved

to be defective within the warranty period. The clock-timer unit must be removed from the radio cabinet when repairs by Sessions are necessary. Sylvania distributors will supply name of the nearest Sessions service station.

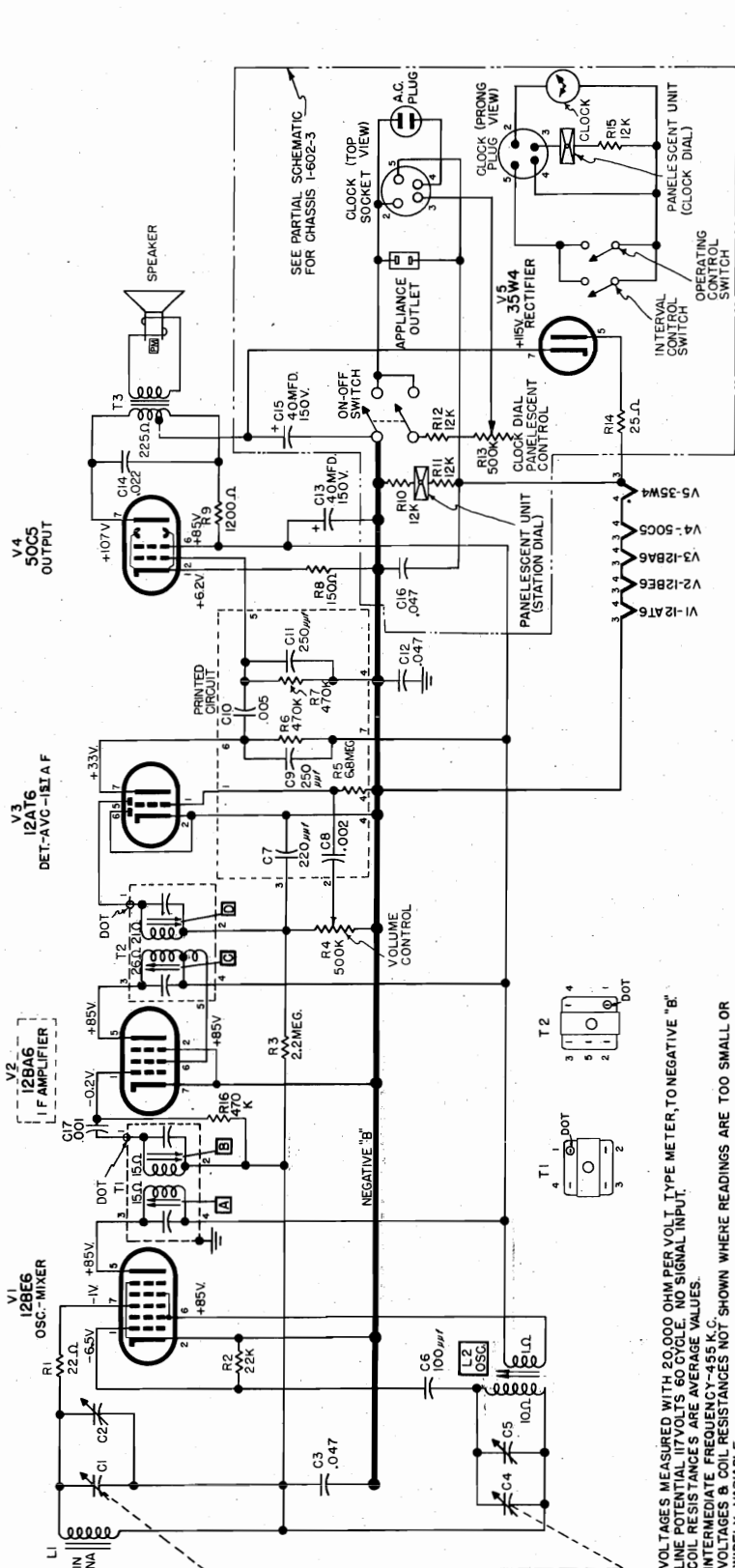

VOLTAGES MEASURED WITH 20,000 OHM PER VOL T TYPE METER TO NEGATIVE "B" LINE POTENTIAL IN VOLTS 60 CYCLE 100 SIGNAL INPUT. COIL RESISTANCES ARE AVERAGE VALUES. INTERMEDIATE FREQUENCY-455 K.C. VOLTAGES & COIL RESISTANCES NOT SHOWN WHERE READINGS ARE TOO SMALL OR WIDELY VARIABLE.

SCHEMATIC DIAGRAM FOR 1-602-2 CHASSIS

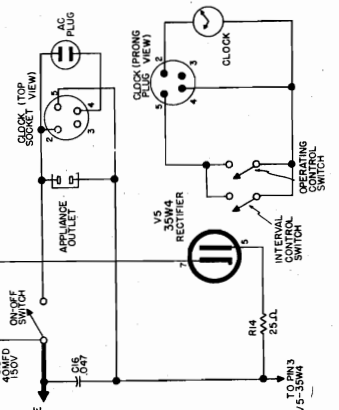

PARTIAL SCHEMATIC CHASSIS 1-602-3 ONLY

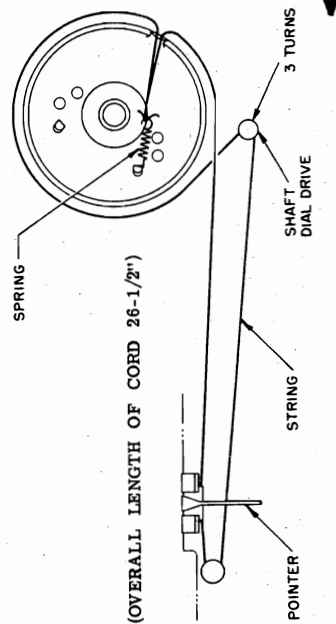

(OVERALL LENGTH OF CORD 26-1/2")

← DIAL CORD HOOKUP

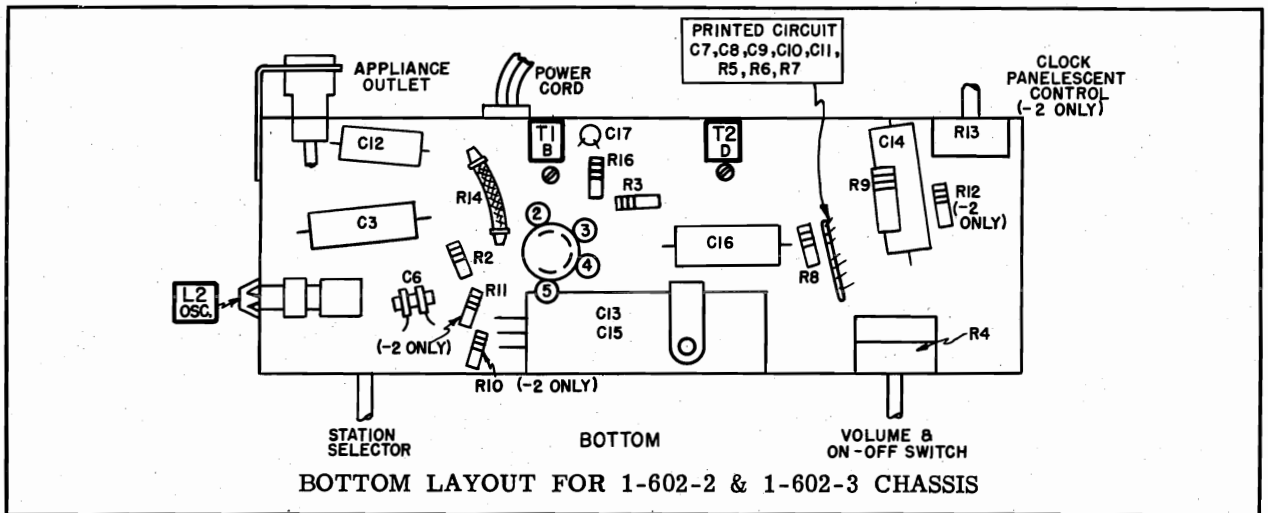
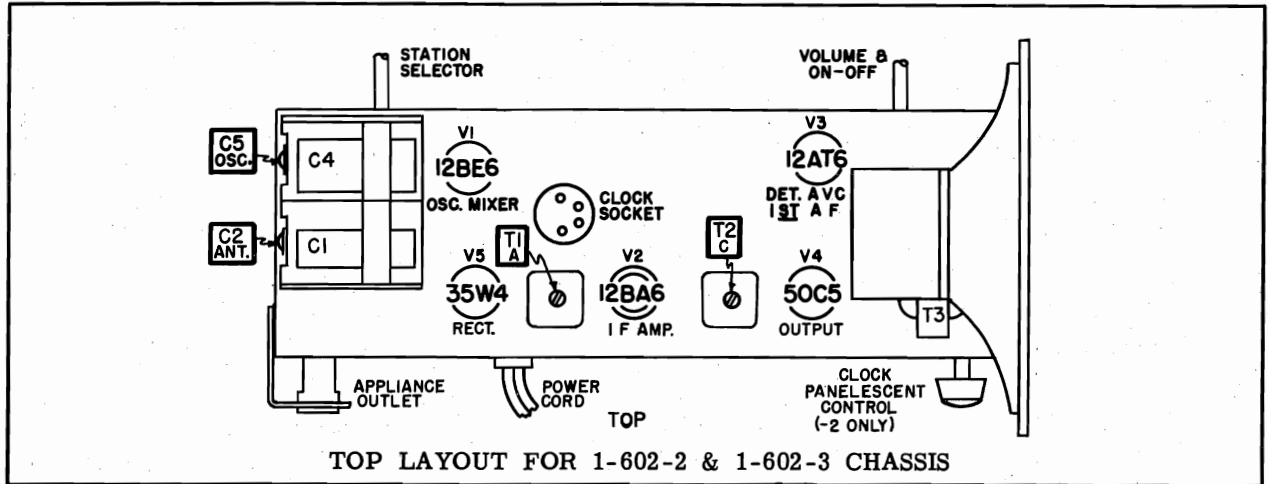

REPAIR PARTS LIST

<u>SCHEMATIC LOCATION</u>	<u>SERVICE PART NUMBER</u>	<u>DESCRIPTION</u>
---------------------------	----------------------------	--------------------

CAPACITORS

C1	170-0009	Variable - 2 Gang (antenna section)
C2		Trimmer (part of C1)
C3	160-04147	.047 Mfd. - 400 V. - Paper
C4	170-0009	Variable - 2 Gang (Oscillator section)
C5		Trimmer (part of C4)
C6	166-0100P	100 Mmfd. - 500 V. - Ceramic
C7, C8, C9 C10, C11		Listed under "Miscellaneous Electrical Parts"
C12	160-04147	.047 Mfd. - 400 V. - Paper
C13	161-2002	40 Mfd. - 150 V. - Electrolytic
C14	162-04122	.022 Mfd. - 400 V. - Paper
C15	161-2002	40 Mfd. - 150 V. - Electrolytic
C16	160-04147	.047 Mfd. - 400 V. - Paper
C17	166-1000D	.001 Mfd. - 500 V. - Ceramic

CHOKES, COILS, AND TRANSFORMERS

L1	582-0017	Loop Antenna (includes back cover)
L2	113-0023	Oscillator Coil
T1	121-0021	1st IF Transformer
T2	122-0023	2nd IF Transformer
T3	143-0028	Audio Output Transformer

PAGE 23-20 SYLVANIA

MODELS 543, 593, Ch.

1-602-2, 1-602-3

<u>SCHEMATIC LOCATION</u>	<u>SERVICE PART NUMBER</u>	<u>DESCRIPTION</u>
<u>MISCELLANEOUS CABINET PARTS</u>		
	714-0013	Bezel
	813-0026	Cabinet - Plastic - Black (Models 543B, 593B)
	813-0029	Cabinet - Plastic - Chartreuse (Models 543CH, 593CH)
	813-0030	Cabinet - Plastic - Green (Models 543GR, 593GR)
	813-0027	Cabinet - Plastic - Ivory (Models 543H, 593H)
	813-0028	Cabinet - Plastic - Mahogany (Models 543M, 593M)
	813-0024	Cabinet - Plastic - Red (Models 543R, 593R)
	813-0031	Cabinet - Plastic - Yellow (Models 543YE, 593YE)
	721-0009	Dial - Clock and Station (Glass)
	487-0018	Fastener - Snap (Loop antenna and back cover mounting)
	740-0038	Knob - Panelescent Dimmer Control (543 models only)
	740-0033	Knob - Tuning, Volume and On/Off

MISCELLANEOUS CHASSIS PARTS

482-0002	Base - Miniature Tube Shield
492-0045	Bracket - Panelescent Station Dial
487-0004	Clip - IF Transformer Mounting
792-0010	Pointer - Station Dial
494-0007	Pulley - Dial Drive
497-0005	Retainer and Bushing - Line Cord
496-0028	Shaft - Tuning
482-0003	Shield - Miniature Tube
419-0005	Socket - 2 Prong - Appliance
419-0009	Socket - 4 Prong - Clock
412-0015	Socket - 7 Prong - Miniature
496-0023	Spring - String Drive

MISCELLANEOUS ELECTRICAL PARTS

R4	152-0019	Control - Volume and On/Off
R13	153-0022	Control - Panelescent Dimmer (Chassis 1-602-2 only)
	195-0011	Cord - Line
	190-0009	Printed Circuit - Detector/Audio Plate
C7		220 Mmfd. - 500 V.
C8		.002 Mfd. - 500 V.
C9		250 Mmfd. - 500 V.
C10		.005 Mfd. - 500 V.
C11		250 Mmfd. - 500 V.
R5		6.8 Megohm - 1/2 W.
R6		470,000 Ohm - 1/2 W.
R7		470,000 Ohm - 1/2 W.
	539-0501	Speaker - 5" P. M.
	924-0003	Unit - Clock Motor (Sessions No. A742)
	477-0005	Unit - Panelescent Light (Clock dial) (Chassis 1-602-2 only)
	477-0004	Unit - Panelescent Light (Station dial) (Chassis 1-602-2 only)

RESISTORS

R1	181-0220	22 Ohm - 1/2 W.
R2	181-0223	22,000 Ohm - 1/2 W.
R3	181-0225	2.2 Megohm - 1/2 W.
R4, R5, R6		Listed under "Miscellaneous Electrical Parts"
R7		
R8	181-0151	150 Ohm - 1/2W.
R9	182-0122	1,200 Ohm - 1 W.
R10	181-0123	12,000 Ohm - 1/2 W. (Chassis 1-602-2 only)
R11	181-0123	12,000 Ohm - 1/2 W. (Chassis 1-602-2 only)
R12	181-0123	12,000 Ohm - 1/2 W. (Chassis 1-602-2 only)
R13		Listed under "Miscellaneous Electrical Parts"
R14	189-0013	25 Ohm - 1W - W. W.
R15	181-0123	12,000 Ohm - 1/2 W. (Chassis 1-602-2 only)
R16	181-0474	470,000 Ohm - 1/2 W.

TUBE COMPLEMENT

V1	12BE6 - Oscillator/Mixer
V2	12BA6 - IF Amplifier
V3	12AT6 - Detector, AVC, 1st Audio Amplifier
V4	50C5 - Audio Output
V5	35W4 - Rectifier

SPECIFICATIONS

Power Supply 105 to 128 V. 60 Cycle AC 80 Watts

Frequency Range

AM Broadcast . . . 540 KC to 1600 KC
FM Broadcast 88 MC to 108 MC

Intermediate Frequency

AM Carrier 455 KC
FM Carrier 10.7 MC

TUBE COMPLEMENT

V1	RF Amplifier - FM	6AU6
V2	Oscillator/Mixer	6BE6
V3	1st IF Amplifier - AM, FM	6BA6
V4	2nd IF Amplifier - FM	6AU6
V5	AM Detector, AVC, 1st AF	6AT6
V6	FM Discriminator	6AL5
V7	Audio Output (1-603-1)	6W6GT
V7	Audio Output (1-603-2)	6AS5
V8	Rectifier	7Z4

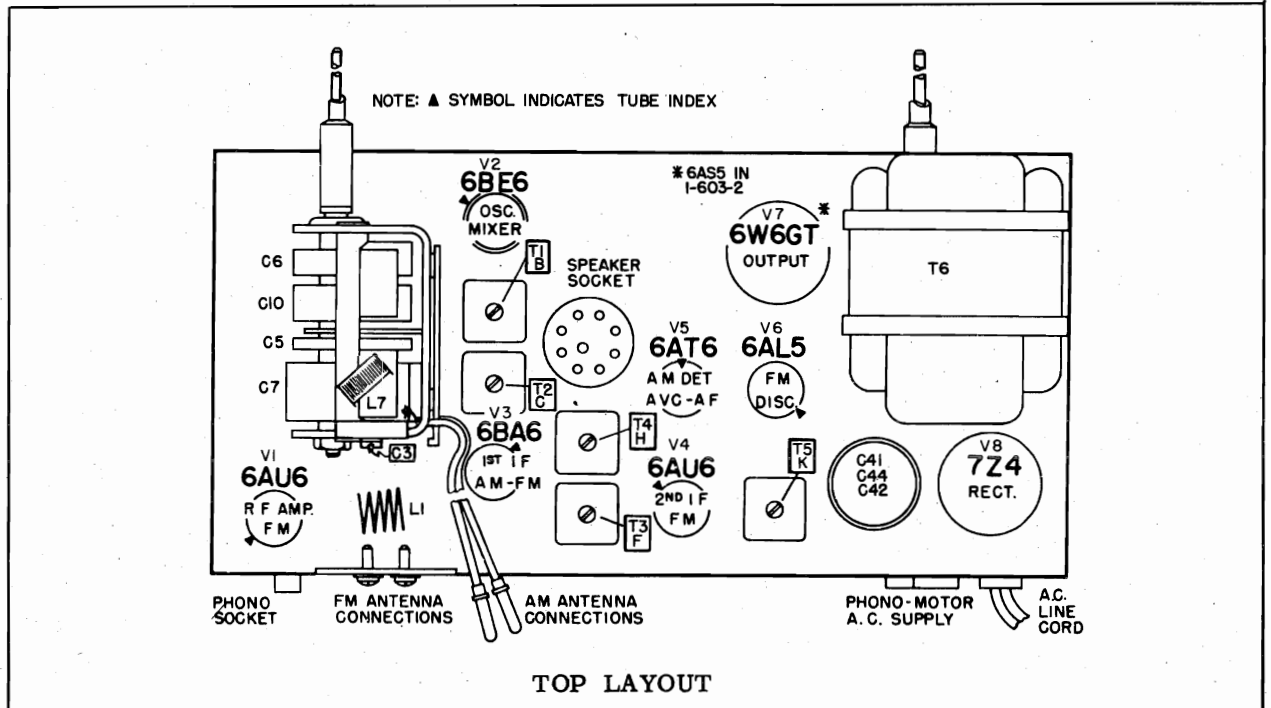

TOP LAYOUT

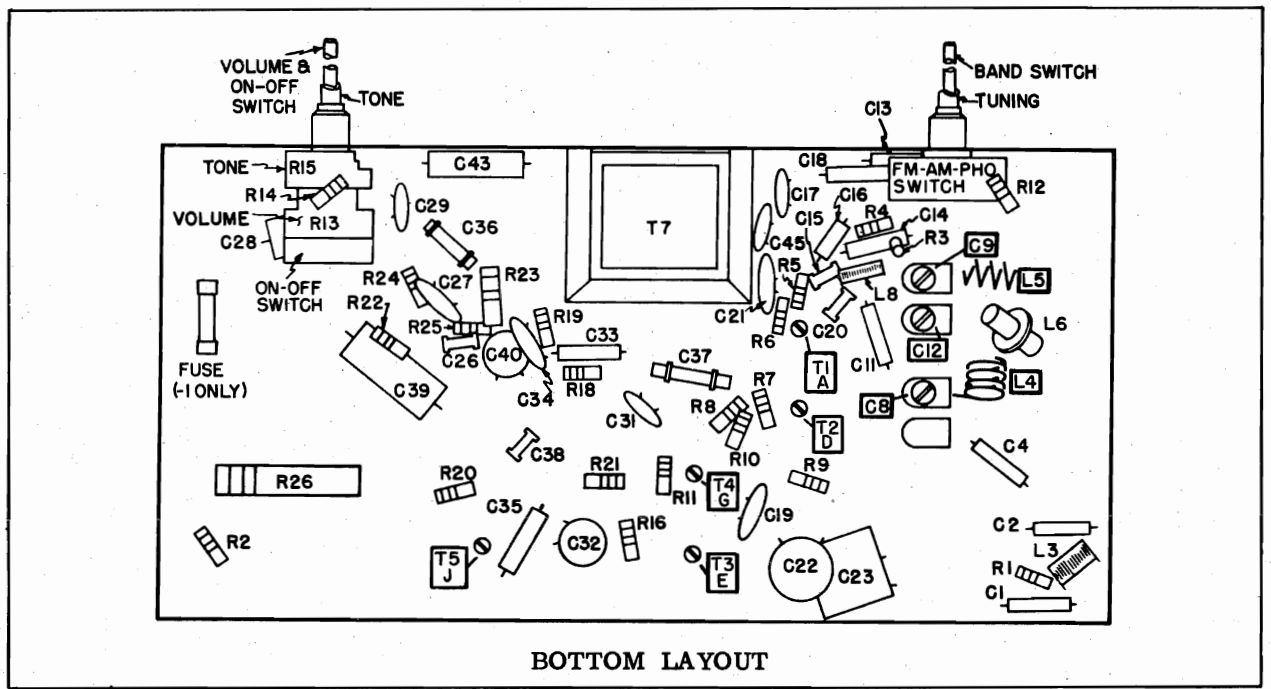

BOTTOM LAYOUT

MODELS 25-M, M-1, 75-B, B-1, -M,
M-1, 178B, BU, M, MU, 373B, BU, M,
MU, Ch. 1-603-1; 388B, BU, M, MU,
Ch. 1-603-2

ALIGNMENT PROCEDURE

GENERAL PREALIGNMENT INSTRUCTIONS

1. Remove chassis from cabinet.
2. Allow receiver and test equipment to warm up for approximately 15 minutes before proceeding with alignment.
3. Use proper insulated alignment tool for powdered iron cores with slots.
4. When constructing FM alignment detector circuit, keep leads short.
5. Ground all test equipment unless otherwise stated.

6. Keep generator output as lowest usable level to prevent AVC action from interfering with accurate alignment.
7. Position FM/AM/PHONO switch as follows:

DESIRED POSITION	BAND SWITCH SETTING
FM	Full Counterclockwise
AM	Center

FM IF ALIGNMENT

STEP	SIGNAL GENERATOR Connection	SIGNAL GENERATOR Freq.	SWEEP GENERATOR Connection	SWEEP GENERATOR Freq.	OSCILLOSCOPE CONNECTION	ADJUST	OUTPUT READING	COMMENTS
1.	Loosely couple marker to pin 1 of 1st IF Amp. - 6BA6	10.6 MC 10.7 MC 10.8 MC	To pin 1 of 1st IF Amp. - 6BA6	10.7 MC	Thru detector circuit of Figure A to pin 5 of 2nd IF Amp. - 6AU6	T3 - F T3 - E	Response curve of Figure B	Connect 500 ohm resistor from pin 5 to pin 6 of 2nd IF Amp. - 6AU6. Obtain maximum vertical amplitude for response curve. Set sweep generator for approximately 500 KC to 1 MC sweep.
2.	Loosely couple marker to pin 7 of Osc. - Mixer - 6BE6.	10.6 MC 10.7 MC 10.8 MC	To pin 7 of Osc. Mixer - 6BE6.	10.7 MC	Same as 1.	T1 - B T1 - A	Response curve of Figure B	Same as 1; reduce sweep generator output to avoid AVC distortion of response curve.
3.	Loosely couple marker to pin 1 of 2nd IF Amp. - 6AU6.	10.6 MC 10.7 MC 10.8 MC	To pin 1 of 2nd IF Amp. - 6AU6	10.7 MC	Across de-emphasis capacitor, C37 .0033 Mfd.	T5 - K T5 - J	Response curve of Figure C	REMOVE 500 OHM RESISTOR ADDED FOR STEP 1. Center 10.7 MC marker. Obtain maximum linear output for response curve.

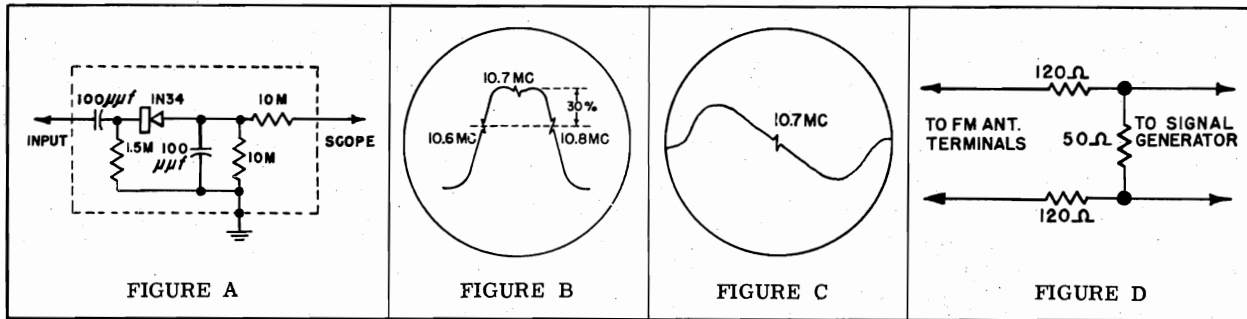

FM RF ALIGNMENT

STEP	SIGNAL GENERATOR Connection	SIGNAL GENERATOR Freq.	TUNING CAPACITOR POSITION	OUTPUT METER CONNECTION	ADJUST	OUTPUT READING	COMMENTS
1.	Thru resistor network of Figure D to FM antenna terminal board.	108.5 MC	Fully open	Across speaker voice coil.	C9	Maximum	Set Volume control to full CW position and set Tone control to full CCW position. Use a 400 cycle modulated signal. Keep generator output at lowest usable value. Leave AM loop antenna leads connected during FM RF alignment.
2.	Same as 1.	108 MC	108 MC	Same as 1.	C8	Maximum	Same as 1 using printed calibration dial on chassis assembly to properly position tuning capacitor.
3.	Same as 1.	87.5 MC	Fully closed	Same as 1.	L5 coil	Maximum	Same as 1 "spiking" (squeezing or spreading turns of coil) L5 for maximum output reading. Use a non-metallic pick for this adjustment.
4.	Same as 1	88 MC	88 MC	Same as 1.	L4 coil	Maximum	Same as 2 "spiking" (squeezing or spreading turns of coil) L4 for maximum output reading. Use a non-metallic pick for this adjustment.

MODELS 25-M, M-1, 75-B, B-1, M, M-1,
178B, BU, M, MU, 373B, BU, M, MU, Ch.
1-603-1: 388B, BU, M, MU, Ch. 1-603-2

AM ALIGNMENT

STEP	SIGNAL GENERATOR Connection	Freq.	TUNING CAPACITOR POSITION	OUTPUT METER CONNECTION	ADJUST	OUTPUT READING	COMMENTS
1.	Thru .1 Mfd. capacitor to pin 7 of Osc.-Mixer - 6BE6.	455 KC	Fully open	Across speaker voice coil.	T4 - H T4 - G T2 - D T2 - C	Maximum	Set Volume control to full CW position and set Tone control to full CCW position. Use a 400 cycle modulated signal. Keep generator output at lowest usable value.
2.	Radiated to receiver thru a wire loop of several turns. or: Thru a 50 Mmfd. capacitor to AM antenna board.	1650 KC	1650 KC	Same as 1.	C12	Maximum	Same as 1 using printed calibration dial on chassis assembly to properly position tuning capacitor.
3.	Same as 2.	1400 KC	1400 KC	Same as 1.	C3	Maximum	Same as 2.

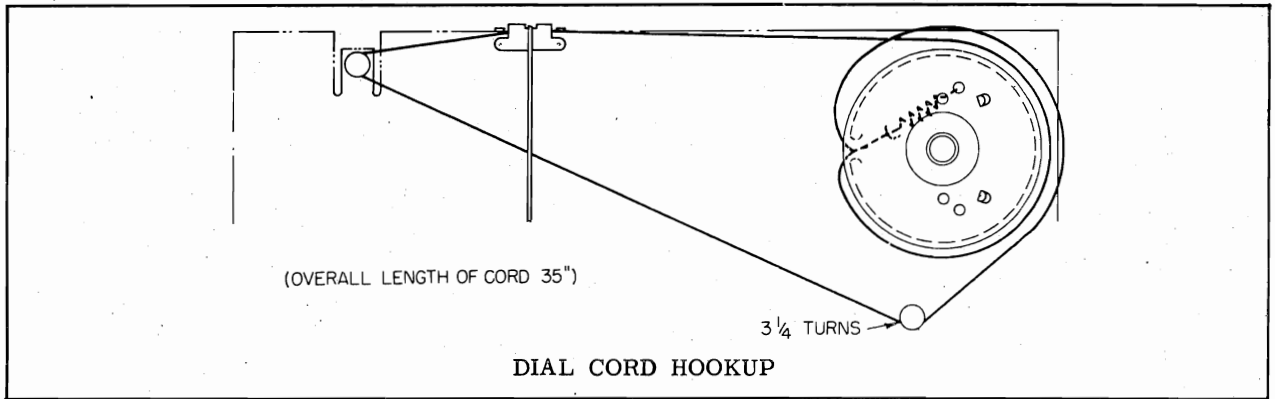

REPAIR PARTS LIST

SCHEMATIC LOCATION	SERVICE PART NUMBER	DESCRIPTION
<u>CAPACITORS</u>		
C1	163-0470	470 Mmfd. - 500 V. - Mica
C2	163-0470	470 Mmfd. - 500 V. - Mica
C3	172-0031	Trimmer - AM Loop Antenna
C4	163-0032	22 Mmfd. - 500 V. - Mica
C5	170-0008	Variable - 4 Gang (FM RF Section)
C6	170-0008	Variable - 4 Gang (FM Oscillator Section)
C7	170-0008	Variable - 4 Gang (AM Antenna Section)
C8		Trimmer (Part of C5)
C9		Trimmer (Part of C6)
C10	170-0008	Variable - 4 Gang (AM Oscillator Section)
C11	163-0470	470 Mmfd. - 500 V. - Mica
C12		Trimmer (Part of C10)
C13	166-0010P	10 Mmfd. - 500 V. - Ceramic
C14	163-0047	47 Mmfd. - 500 V. - Mica
C15	165-0006A	6 Mmfd. - 500 V. - Ceramic
C16	165-0006A	6 Mmfd. - 500 V. - Ceramic
C17	166-4700D	.0047 Mfd. - 500 V. - Ceramic
C18	163-0470	470 Mmfd. - 500 V. - Mica
C19	168-0002D	.01 Mfd. - 500 V. - Ceramic
C20	166-0470N	470 Mmfd. - 500 V. - Ceramic
C21	168-0002D	.01 Mfd. - 500 V. - Ceramic
C22	168-0002D	.01 Mfd. - 500 V. - Ceramic
C23	163-3900	.0039 Mfd. - 500 V. - Mica
C24	163-0100	100 Mmfd. - 500 V. - Mica (Part of T4)
C25	163-0100	100 Mmfd. - 500 V. - Mica (Part of T4)
C26	166-0270N	270 Mmfd. - 500 V. - Ceramic
C27	168-0002D	.01 Mfd. - 500 V. - Ceramic
C28	163-0047	47 Mmfd. - 500 V. - Mica
C29	166-4700D	.0047 Mfd. - 500 V. - Ceramic
C30	168-0002D	.01 Mfd. - 500 V. - Ceramic (Chassis 1-603-2 only)
C31	166-4700D	.0047 Mfd. - 500 V. - Ceramic
C32	166-4700D	.0047 Mfd. - 500 V. - Ceramic
C33	163-0100	100 Mmfd. - 500 V. - Mica
C34	168-0002D	.01 Mfd. - 500 V. - Ceramic
C35	160-06218	.0018 Mfd. - 600 V. - Paper - Molded
C36	166-2000P	.002 Mfd. - 500 V. - Ceramic
C37	166-3300P	.0033 Mfd. - 500 V. - Ceramic

CHASSIS 1-603-1,
1-603-2

SCHEMATIC LOCATION	SERVICE PART NUMBER	DESCRIPTION
<u>CAPACITORS (CONT'D)</u>		
C38	166-0470N	470 Mmfd. - 500 V. - Ceramic
C39	161-1008	4 Mfd. - 50 V. - Electrolytic
C40	168-0002D	.01 Mfd. - 500 V. - Ceramic
C41	161-3011	25 Mfd. - 25 V. - Electrolytic
C42	161-3011	60 Mfd. - 250 V. - Electrolytic Δ
C43	160-0411	.01 Mfd. - 400 V. - Paper - Molded
C44	161-3011	60 Mfd. - 250 V. - Electrolytic \square
C45	166-4700D	.0047 Mfd. - 500 V. - Ceramic
<u>CHOKES, COILS, AND TRANSFORMERS</u>		
L1	111-0012	FM Antenna Coil
L2	582-0012	AM Loop Antenna
L3	146-0014	FM RF Plate Choke
L4	112-0009	FM RF Plate Coil Assembly
L5	113-0021	FM Oscillator Coil
L6	113-0011	AM Oscillator Coil
L7	146-0014	AM Antenna Choke
L8	146-0013	Oscillator/Mixer Cathode Choke
T1	121-0017	1st IF Transformer (FM)
T2	121-0018	1st IF Transformer (AM)
T3	122-0017	2nd IF Transformer (FM)
T4	122-0019	2nd IF Transformer (AM)
T5	128-0007	FM Discriminator Transformer
T6	141-0017	117 V. 60 Cycle Power Transformer (Chassis 1-603-1 only)
T6	141-0036	117 V. 60 Cycle Power Transformer (Chassis 1-602-2 only)
T7	143-0018	Audio Output Transformer
<u>MISCELLANEOUS CHASSIS PARTS</u>		
	726-0003	Background - Dial
	416-0011	Board - Antenna (FM)
	497-0005	Bushing and Retainer - Line Cord
	497-0013	Bushing - Rubber
	487-0013	Button - Snap
	487-0004	Clip - IF Transformer Can Mounting
	554-0019	Clip - Tuning Shaft Retaining
	417-0006	Connector Pin - Antenna Lead
	722-0020	Dial - Station
	497-0012	Grommet - Rubber
	792-0007	Pointer - Dial
	494-0007	Pulley - Dial Drive
	493-0016	Shaft - Tuning
	482-0007	Shield - Miniature Tube
	411-0007	Socket - Dial Light
	417-0002	Socket - 1 Prong - Phono Input
	417-0009	Socket - 2 Prong - Phono Motor
	412-0015	Socket - 7 Prong Miniature
	412-0020	Socket - 7 Prong Miniature - Mica filled
	412-0003	Socket - 8 Prong Octal
	412-0001	Socket - 8 Prong Lock-in
	419-0003	Socket - 8 Prong - Speaker
	496-0023	Spring - Drive String Tension
<u>MISCELLANEOUS ELECTRICAL PARTS</u>		
	157-0017	Control-Dual-Tone, Volume and On/Off
R13		Control-Volume
R15		Control-Tone
	195-0008	Cord and Receptacle Assembly
	195-0002	Cord - Line
	611-0047	Lamp - #47
	573-0004	Switch - FM/AM/PHONO
<u>RESISTORS</u>		
R1	181-0121	120 Ohm - 1/2 W.
R2	181-0181	180 Ohm - 1/2 W.
R3	181-0223	22,000 Ohm - 1/2 W.
R4	181-0101	100 Ohm - 1/2 W.
R5	181-0105	1 Megohm - 1/2 W.
R6	181-0270	2,700 Ohm - 1/2 W.
R7	181-0181	180 Ohm - 1/2 W.
R8	181-0225	2.2 Megohm - 1/2 W.
R9	181-0680	68 Ohm - 1/2 W.
R10	181-0272	2,700 Ohm - 1/2 W.
R11	181-0473	47,000 Ohm - 1/2 W.
R12	181-0474	470,000 Ohm - 1/2 W.
R13		Listed under "Miscellaneous Electrical Parts"
R14	181-0473	47,000 Ohm - 1/2 W.
R15		Listed under "Miscellaneous Electrical Parts"
R16	181-0101	100 Ohm - 1/2 W.
R17	181-0106	10 Megohm - 1/2 W. (Chassis 1-603-2 only)
R18	181-0106	10 Megohm - 1/2 W.
R19	181-0474	470,000 Ohm - 1/2 W.
R20	181-0181	180 Ohm - 1/2 W.
R21	181-0223	22,000 Ohm - 1/2 W.
R22	181-0223	22,000 Ohm - 1/2 W.
R23	189-0007	4.3 Ohm - 1/2 W. - W.W.
R24	182-0181	180 Ohm - 1 W. (Chassis 1-603-1 only)
R24	182-0221	220 Ohm - 1 W. (Chassis 1-603-2 only)
R25	181-0474	470,000 Ohm - 1/2 W.
R26	187-0009	1,850 Ohm - 5 W. - W.W. (Chassis 1-603-1 only)
R26	187-0015	1,600 Ohm - 5 W. - W.W. (Chassis 1-603-2 only)

MODELS 25-M, M-1, 75-B, B-1, M, M-1, 178B, BU, M, MU, 373B, BU, M, MU, Ch. 1-603-1

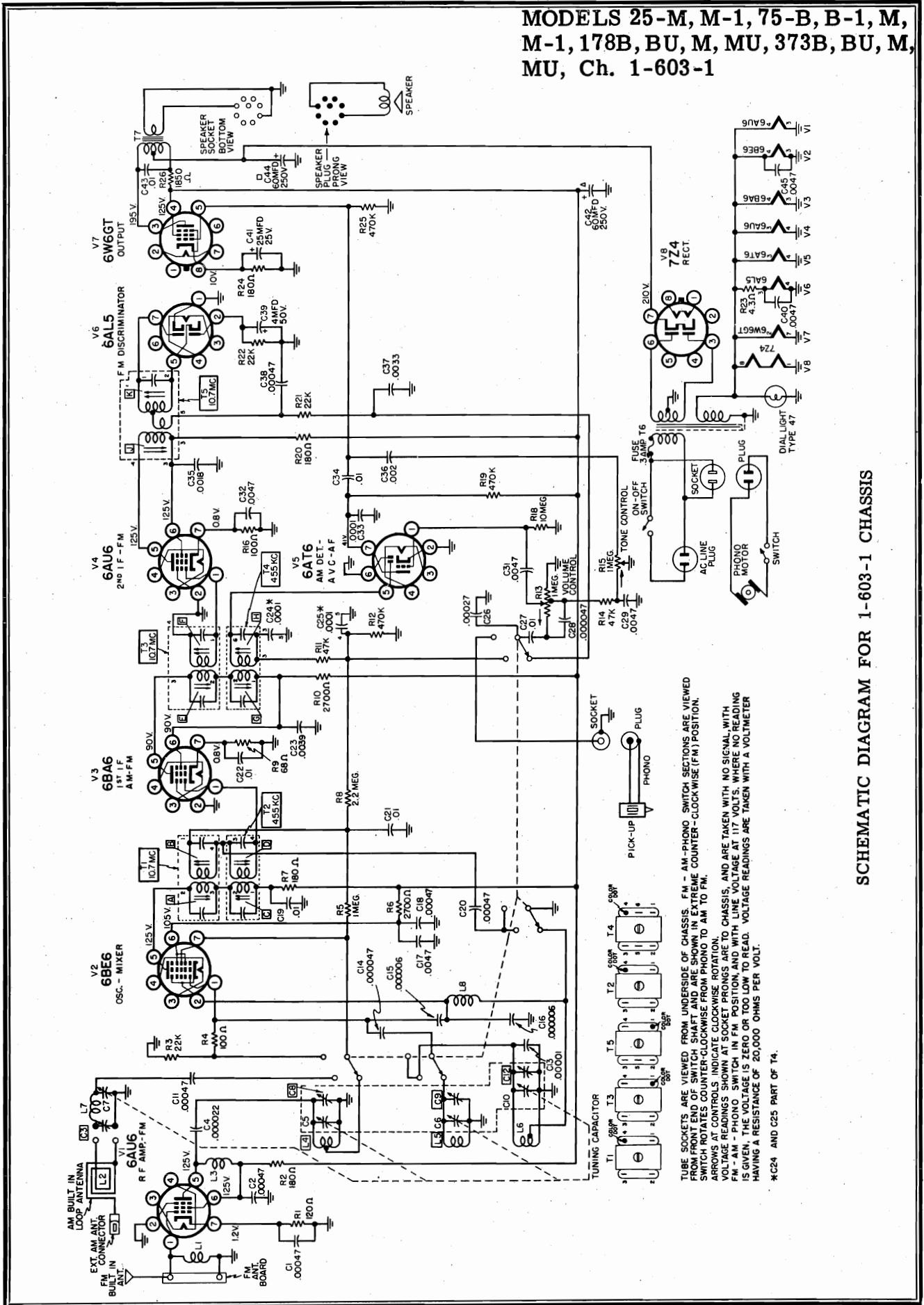

TUBE SOCKETS ARE VIEWED FROM UNDERSIDE OF CHASSIS. FM - AM-PHONO SWITCH SECTIONS ARE VIEWED FROM FRONT END OF SWITCH SHAFT AND ARE SHOWN IN EXTREME COUNTER-CLOCKWISE (FM) POSITION. SWITCH ROTATES COUNTER-CLOCKWISE FROM PHONO TO AM TO FM. ARROWS AT CONTROLS INDICATE CLOCKWISE ROTATION. *C24 AND C25 PART OF T4. *C24 AND C25 PART OF T4.

SCHEMATIC DIAGRAM FOR 1-603-1 CHASSIS

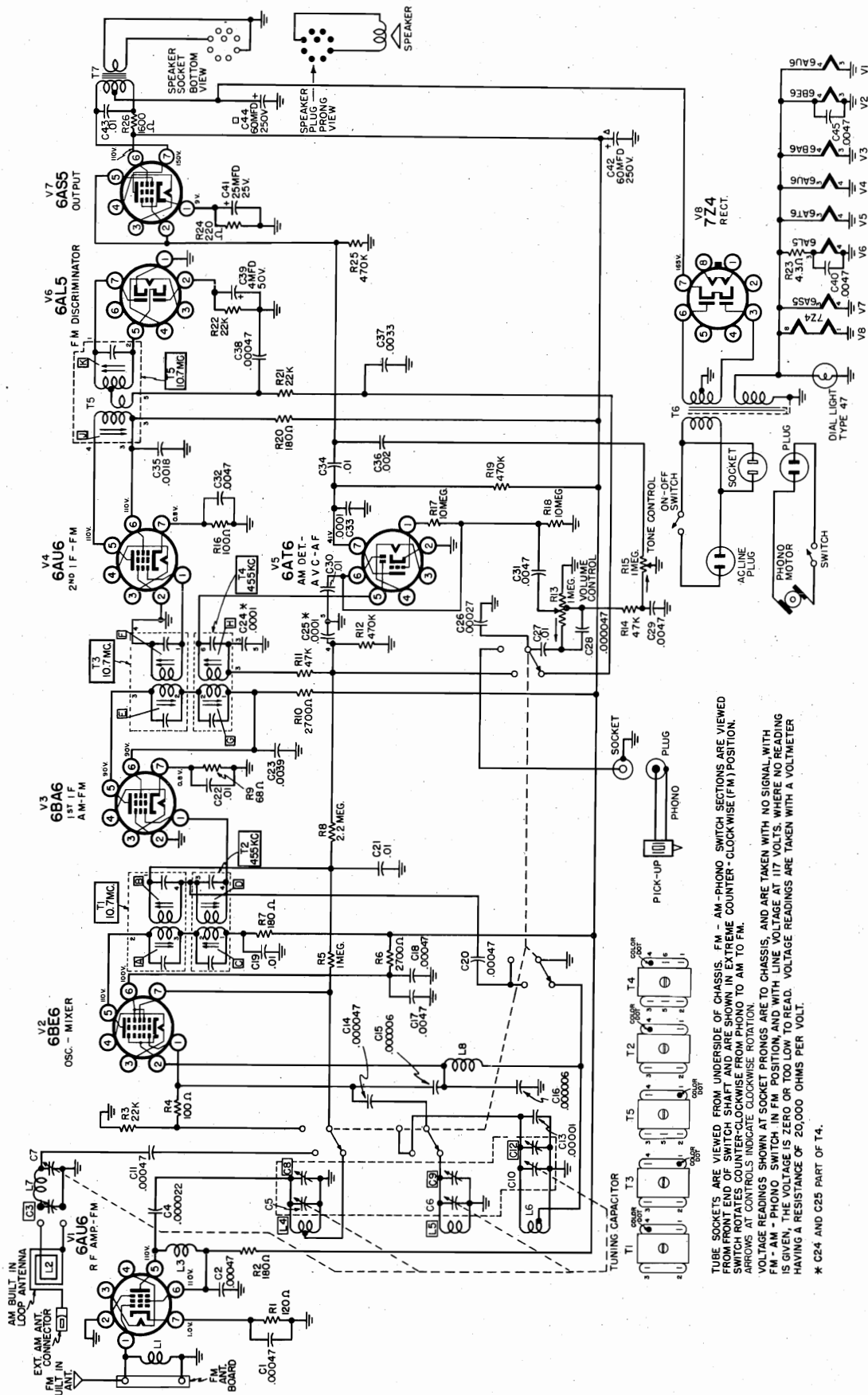

SCHEMATIC DIAGRAM FOR 1-603-2 CHASSIS

TUBE SOCKETS ARE VIEWED FROM UNDERSIDE OF CHASSIS. FM - AM - PHONO SWITCH SECTIONS ARE VIEWED FROM FRONT END OF SWITCH SHAFT AND ARE SHOWN IN EXTREME COUNTER - CLOCKWISE (FM) POSITION. ARROWS AT CONTROLS INDICATE CLOCKWISE ROTATION.

VOLTAGE READINGS SHOWN AT SOCKET PRONGS ARE TO CHASSIS, AND ARE TAKEN WITH NO SIGNAL, WITH FM - AM - PHONO SWITCH IN FM POSITION, AND WITH LINE VOLTAGE AT 117 VOLTS. WHERE NO READING IS GIVEN, THE VOLTAGE IS ZERO OR TOO LOW TO READ. VOLTAGE READINGS ARE TAKEN WITH A VOLTMETER HAVING A RESISTANCE OF 20,000 OHMS PER VOLT.

* C24 AND C25 PART OF T4.



TUBE		P I N S						
	No. 1	No. 2	No. 3	No. 4	No. 5	No. 6	No. 7	
35W4	—	—	85 AC	120 AC	120 AC	—	130 V	
50C5	0	-9.8 V	26 AC	76 AC	—	110 V	120 V	"4 Tube Radio"
12BE6	-10 V	0 V	26 AC	13 AC	105 V	105 V	-8 V	
12AT6	-1 V	0 V	0 AC	13 AC	-8 V	-7 V	58 V	

Voltage readings made with V.T.VM from pins designated to B—.

ALIGNMENT CHART

STEPS	ALIGN	DUMMY ANTENNA	GENERATOR FREQUENCY	DIAL SETTING	CONNECT GENERATOR TO	ADJUST	OUTPUT METER ACROSS VOICE COIL
1	I.F.	.05	455 KC	High Freq. End	Pin 7—12BE6 Converter Grid	T-1 Double Slug	Peak for Max.
2	Osc.	.05	1650 KC	High Freq. End	Pin 7—12BE6 Converter Grid	C10B Osc. Tuner Trim	Peak for Max.
3	Hank Ant.	100 mmf.	1500 KC	1500 KC	Ant. Lead	C10A R.F. Tuner Trim	Peak for Max.
4	Repeat Steps 2 and 3						

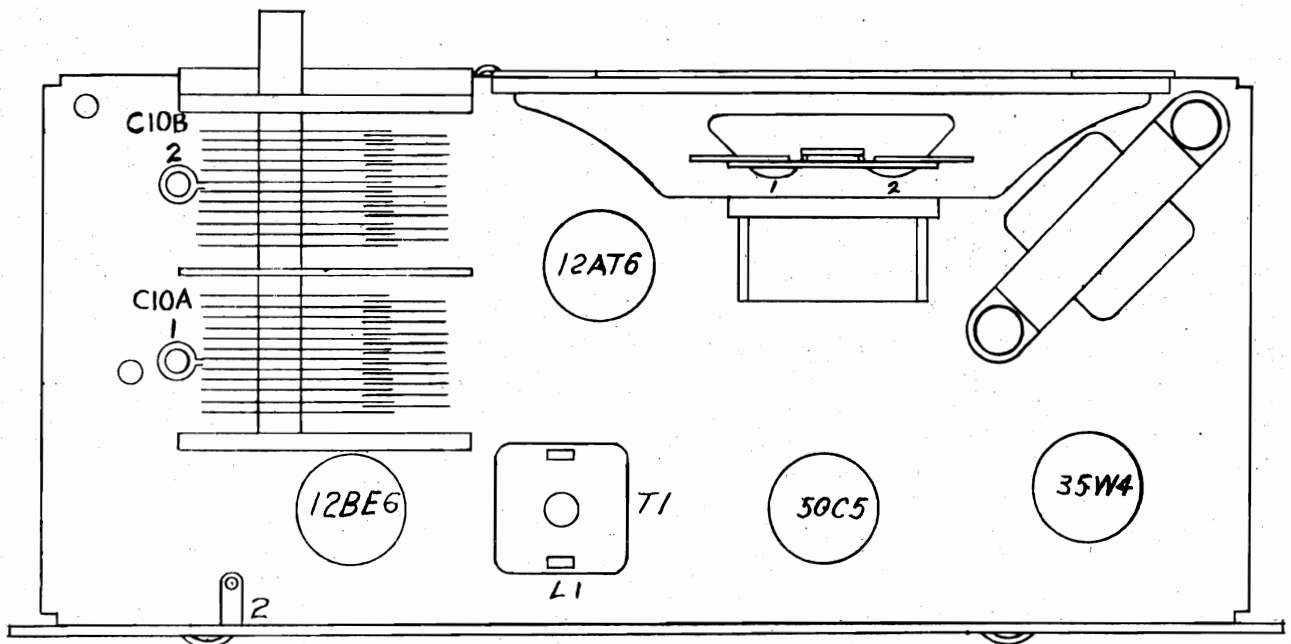

TOP VIEW

MODEL RK-41,
Ch. RD-1

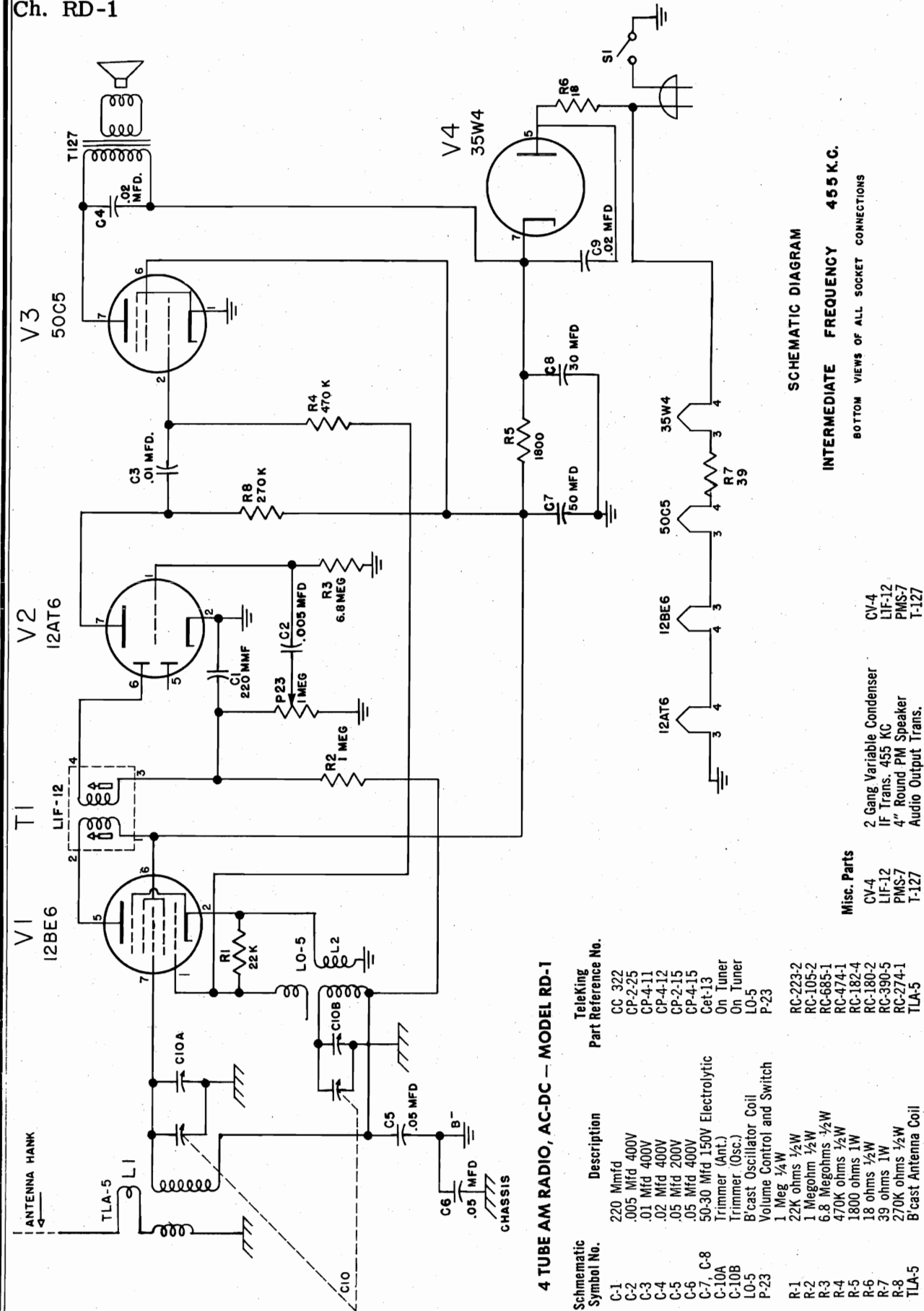

4 TUBE AM RADIO, AC-DC — MODEL RD-1

Schematic Symbol No.	Description	Part Reference No.	Teleking
C-1	220 Mmfd	CC 322	
C-2	.005 Mfd 400V	CP-2-25	
C-3	.01 Mfd 400V	CP-4-11	
C-4	.02 Mfd 400V	CP-4-12	
C-5	.05 Mfd 200V	CP-2-15	
C-6	.05 Mfd 400V	CP-4-15	
C-7, C-8	50-30 Mfd 150V Electrolytic	Cet-13	
C-10A	Trimmer (Osc.)	On Tuner	
C-10B	B cast Oscillator Coil	L0-5	
L0-5	Volume Control and Switch	P-23	
P-23	1 Meg 1/2W		
R-1	22K ohms 1/2W	RC-223-2	
R-2	1 Megohm 1/2W	RC-105-2	
R-3	6.8 Megohms 1/2W	RC-685-1	
R-4	470K ohms 1/2W	RC-474-1	
R-5	1800 ohms 1W	RC-182-4	
R-6	18 ohms 1W	RC-180-2	
R-7	39 ohms 1W	RC-390-5	
R-8	270K ohms 1/2W	RC-274-1	
TLA-5	B cast Antenna Coil	TLA-5	

Misc. Parts
CV-4
LIF-12
PMS-7
T-127

2 Gang Variable Capacitor
IF Trans. 455 KC
4" Round PM Speaker
Audio Output Trans.

SCHEMATIC DIAGRAM

INTERMEDIATE FREQUENCY 455 K.C.

BOTTOM VIEWS OF ALL SOCKET CONNECTIONS



LINE VOLTAGE: 117 VOLTS AC				FULL VOLUME CONTROL — NO SIGNAL				
TUBE	Pin #1	Pin #2	Pin #3	Pin #4	Pin #5	Pin #6	Pin #7	
1R5	1.25 V	98 V	48 V	-10 V	1.25 V	-.4 V	2.5 V	
1U5	0 V	25 V	26 V	-.4 V	0 V	-.2 V	1.25 V	PORTABLE RADIO
1U4	2.5 V	98 V	97 V	0 V	2.5 V	1.3 V	3.75 V	
3V4	3.75 V	93 V	97 V	0 V	5.1 V	0 V	6.3 V	

Voltage readings made with V.T. VM from pins designated to B—.
 B+ at input filter — 125V DC.
 B+ at output filter — 98V DC.

ALIGNMENT CHART

STEPS	ALIGN	DUMMY ANTENNA	GENERATOR FREQUENCY	DIAL SETTING	CONNECT GENERATOR TO	ADJUST	OUTPUT METER ACROSS VOICE COIL
1	2nd I.F.	.05	455 KC	High Freq. End	Pin 6—1R5 Converter Grid	T-2 Double Slug	Peak for Max.
2	1st I.F.	.05	455 KC	High Freq. End	Pin 6—1R5 Converter Grid	T-1 Double Slug	Peak for Max.
3	Osc.	.05	1650 KC	High Freq. End	Pin 6—1R5 Converter Grid	C19B Osc. Tuner Trim	Peak for Max.
4	Loop Ant.	Radiate into Loop Ant.	1500 KC	1500 KC	Several Turns Around Loop	C19A Loop Tuner Trim	Peak for Max.
5	Repeat Steps 3 and 4						

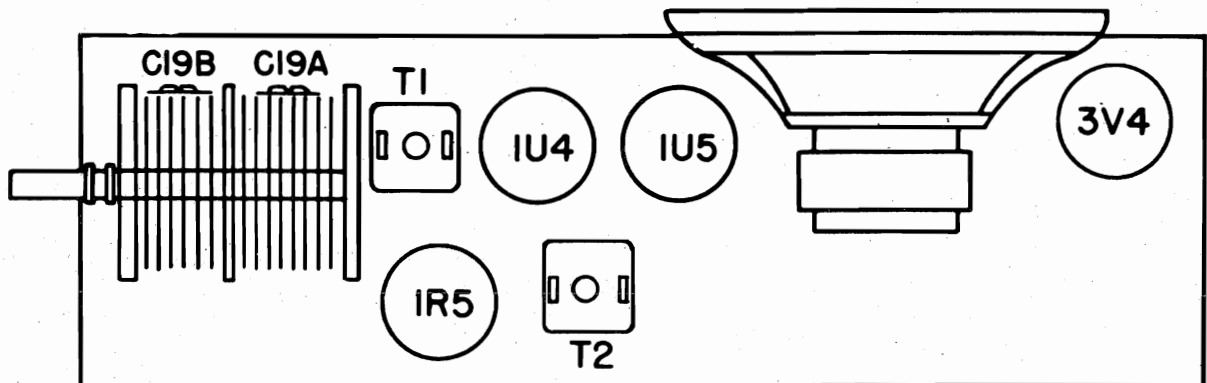

TOP VIEW

MODEL RKP-53,
Ch. REP-1

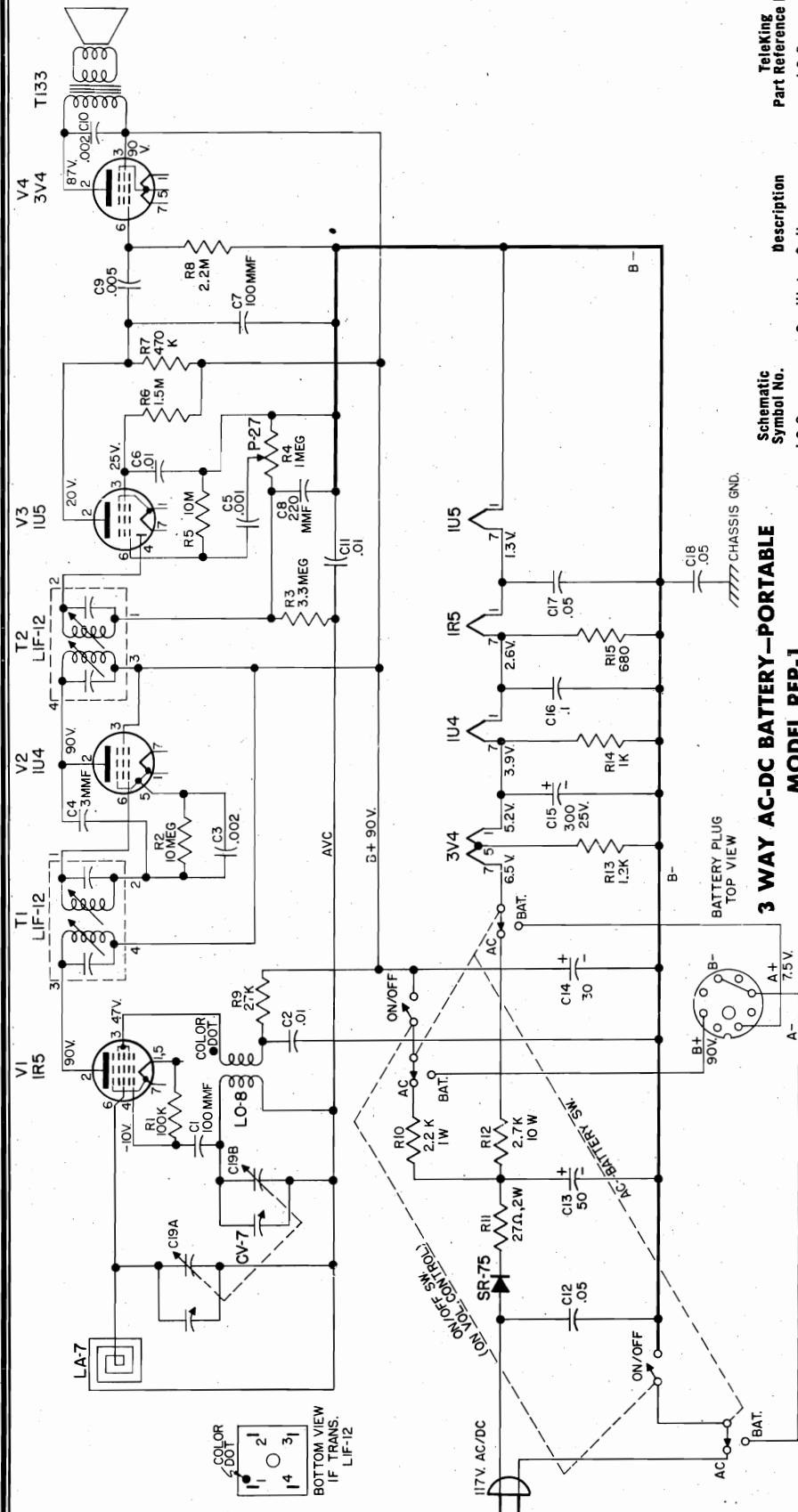

SCHEMATIC DIAGRAM

Schematic Symbol No.	Description	TeleKing Part Reference No.
C-1, C-7	100 MMfd-500V Tubular	CC-31-B
C-2, C-6, C-11	.01 Mfd-200V	CPM-2-11
C-3, C-10	.002-600V	CPM-6-22
C-4	3 MMfd-500V Miniature	CC-53
C-5	.001 Mfd-200V	CPM-2-21
C-8	220 MMfd-500V	CC-322
C-9	.005 Mfd-200V	CPM-2-25
C-12, C-18, C-17	.05 Mfd-200V	CPM-2-15
C-13, C-14, C-15	50-30 Mfd 150V 300 Mfd-25V Electrolytic (Can)	CEM-20
C-16	.1 Mfd-200V	CPM-2-01
C-19A, C-19B	Variable Capacitor	CV-7
LA-7	B'cast Loop Antenna	LA-7
T-1	117V AC/DC	(LIF-12)
T-2	500V 3MMF	(LIF-12)
T-3	20V 10U5	(LIF-12)
T-4	3V4	(LIF-12)
T-5	87V .002 LIC	(LIF-12)
T-6	Audio Output Trans.	T-133

**3 WAY AC-DC BATTERY-PORTABLE
MODEL REP-1**

Schematic Symbol No.	Description	TeleKing Part Reference No.
SR-75	Rectifier	SR-75
R-1	100K ohms 1/2W	R-1
R-2, R-5	10 Meg ohm 1/2W	R-2, R-5
R-3	3.3 Meg ohm 1/2W	R-3
R-6	1.5 Meg ohm 1/2W	R-6
R-7	470K ohm 1/2W	R-7
R-8	2.2 Meg ohm 1/2W	R-8
R-9	27K ohm 1W	R-9
R-10	2.2K ohm 1W	R-10
R-11	27 ohm 2W	R-11
R-12	2.7K ohm 10W Wire Wound	R-12
R-13	1.2K ohm 1/2W	R-13
R-14	1K ohm 1/2W	R-14
R-15	680 ohm 1/2W	R-15
T-1, T-2	IF Trans. 455 KC	(LIF-12)
T-3	Audio Output Trans.	T-133

- BATTERY SWITCH SHOWN IN AC/DC POSITION.
- ON/OFF SWITCH SHOWN IN "OFF" POSITION.
- VOLTAGES MEASURED TO COMMON WIRING (B-) WITH A VTVM AND SHOULD HOLD WITHIN ±10% WITH 117 V. AC LINE.
- VALUE OF ALL CAPACITORS IN MFD. UNLESS OTHERWISE SPECIFIED.

MODEL RK51,
Ch. RE-1

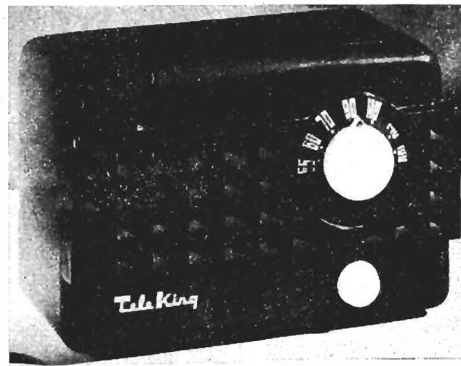

LINE VOLTAGE: 120 VOLTS AC				FULL VOLUME CONTROL — NO SIGNAL			
TUBE	P I N S						
	No. 1	No. 2	No. 3	No. 4	No. 5	No. 6	No. 7
35W4	—	—	88 AC	120 AC	120 AC	—	125 V
50C5	6.4 V	0 V	36 AC	88 AC	0 V	98 V	115 V
12BE6	-7.4 V	0 V	24 AC	36 AC	98 V	98 V	-8 V
12BA6	-1 V	0 V	24 AC	12 AC	96 V	98 V	1.3 V
12AT6	-1 V	0 V	0 AC	12 AC	-1.2 V	-9 V	52 V

Voltage readings made with V.T.VM from pins designated to B—.

ALIGNMENT CHART

STEPS	ALIGN	DUMMY ANTENNA	GENERATOR FREQUENCY	DIAL SETTING	CONNECT GENERATOR TO	ADJUST	OUTPUT METER ACROSS VOICE COIL
1	2nd I.F.	.05	455 KC	High Freq. End	Pin 7—12BE6 Converter Grid	T-2 Double Slug	Peak for Max.
2	1st I.F.	.05	455 KC	High Freq. End	Pin 7—12BE6 Converter Grid	T-1 Double Slug	Peak for Max.
3	Osc.	.05	1650 KC	High Freq. End	Pin 7—12BE6 Converter Grid	C11B Osc. Tuner Trim	Peak for Max.
4	Loop Ant.	Radiate into Loop Ant.	1500 KC	1500 KC	Several Turns Around Loop	C11A Loop Tuner Trim	Peak for Max.
5	Repeat Steps 3 and 4						

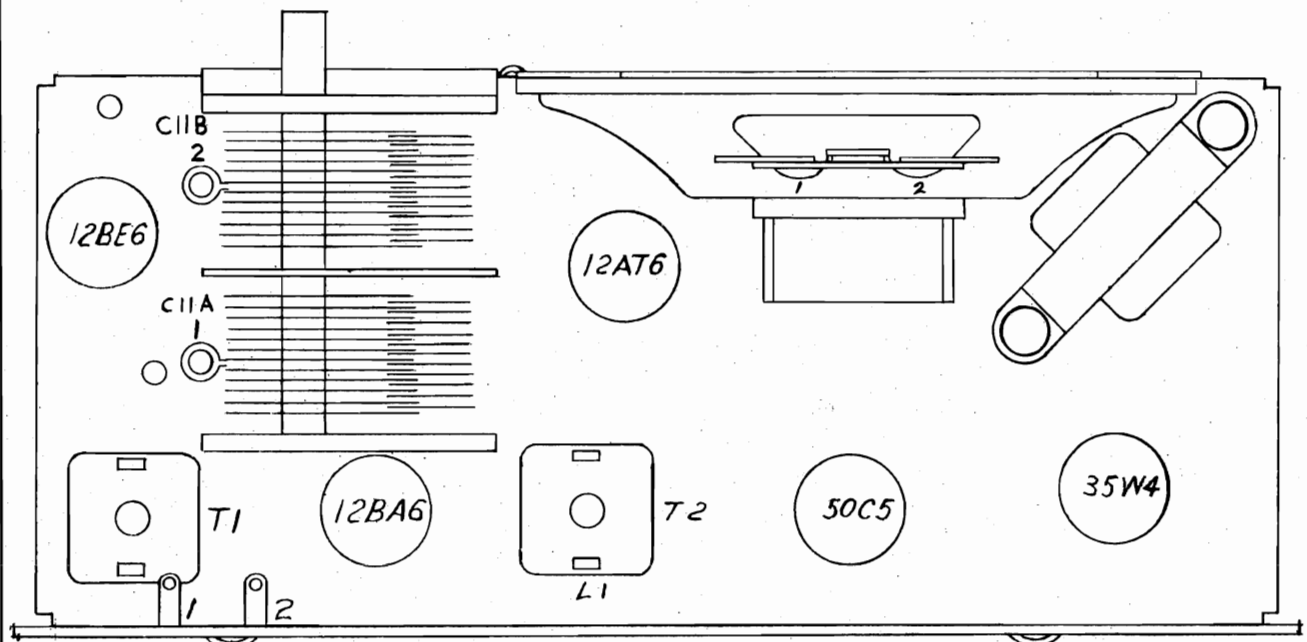

TOP VIEW

MODEL RK51,
Ch. RE-1

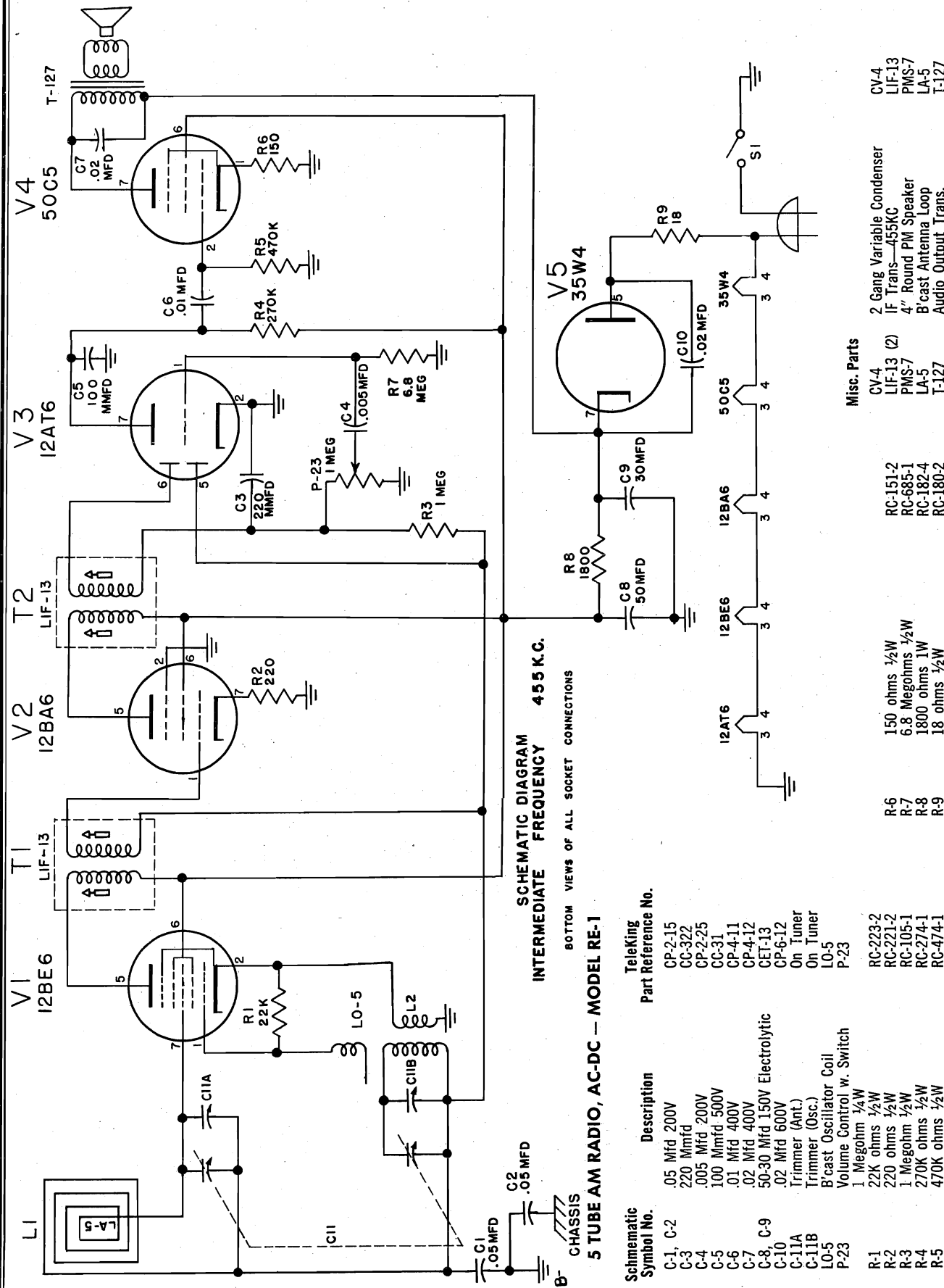

Schematic Symbol No.	Description	Teleking Part Reference No.
C-1, C-2	.05 Mfd 200V	CP-2-15
C-3	220 Mmfd	CC-322
C-4	.005 Mfd 200V	CP-2-25
C-5	100 Mmfd 500V	CC-31
C-6	.01 Mfd 400V	CP-4-11
C-7	.02 Mfd 400V	CP-4-12
C-8, C-9	50-30 Mfd 150V Electrolytic	CET-13
C-10	.02 Mfd 600V	CP-6-12
C-11A	Trimmer (Ant.)	On Tuner
C-11B	Trimmer (Osc.)	On Tuner
L0-5	B'cast Oscillator Coil	L0-5
P-23	Volume Control w. Switch	P-23
R-1	1 Megohm 1/4W	RC-223-2
R-2	22K ohms 1/2W	RC-221-2
R-3	220 ohms 1/2W	RC-105-1
R-4	1 Megohm 1/2W	RC-274-1
R-5	270K ohms 1/2W	RC-474-1
	470K ohms 1/2W	
	150 ohms 1/2W	R-6
	6.8 Megohms 1/2W	R-7
	1800 ohms 1W	R-8
	18 ohms 1/2W	R-9
	RC-151-2	
	RC-685-1	
	RC-182-4	
	RC-180-2	
	CV-4	
	LIF-13 (2)	
	PMS-7	
	LA-5	
	T-127	
	2 Gang Variable Condenser	CV-4
	IF Trans-455KC	LIF-13
	4" Round PM Speaker	PMS-7
	B'cast Antenna Loop	LA-5
	Audio Output Trans.	T-127

LINE VOLTAGE: 117 VOLTS AC		FULL VOLUME CONTROL — NO SIGNAL						
TUBE COMPLEMENT	P I N S							
	No. 1	No. 2	No. 3	No. 4	No. 5	No. 6	No. 7	No. 8
35Z5	—	117 AC	—	—	—	117 AC	90 AC	120 V
50L6	—	90 AC	110 V	95 V	0 V	—	38 AC	7 V
12SQ7	—	—8 V	0 V	—7 V	—7 V	52 V	12.5 AC	0 AC
12SK7	—	38 AC	0 V	—8 V	0 V	96 V	25 AC	96 V
12SA7	—	25 AC	96 V	96 V	—7 V	0 V	12.5 AC	—8 V

Voltage readings made with V.T.VM from pins designated to B—

ALIGNMENT CHART

STEPS	ALIGN	DUMMY ANTENNA	GENERATOR FREQUENCY	DIAL SETTING	CONNECT GENERATOR TO	ADJUST	OUTPUT METER ACROSS VOICE COIL
1	2nd I.F.	.05	455 KC	High Freq. End	Pin 8—12SA7 Converter Grid	T-2 Double Slug	Peak for Max.
2	1st I.F.	.05	455 KC	High Freq. End	Pin 8—12SA7 Converter Grid	T-1 Double Slug	Peak for Max.
3	Osc.	.05	1650 KC	High Freq. End	Pin 8—12SA7 Converter Grid	C11B Osc. Tuner Trim	Peak for Max.
4	Loop Ant.	Radiate into Loop Ant.	1500 KC	1500 KC	Several Turns Around Loop	C11A Loop Tuner Trim	Peak for Max.
5	Repeat Steps 3 and 4						

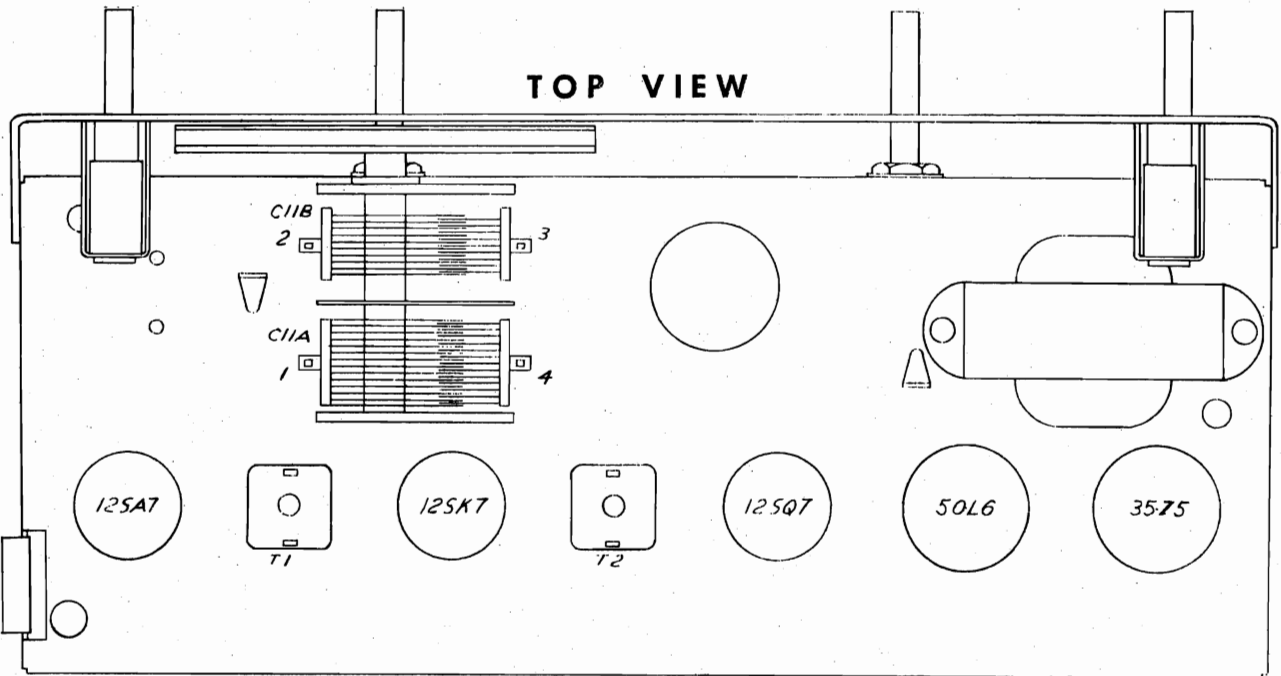

5 TUBE AM RADIO MODEL RE-2A USED IN COMBINATIONS		
Schematic Symbol No.	Description	TeleKing Part Reference No.
C-1, C-7	.01 Mfd 400V	CP-4-11
C-2	.02 Mfd 400V	CP-4-12
C-3	.1 Mfd 600V	CP-6-01
C-4	.47 Mfd 500V	CM-4-07
C-5	.0047 Mfd 500V	CE-1-17
C-6	25 Mid 50V Electrolytic	CP-4-427
C-8	.05 Mfd 600V	CP-6-15
C-9, C-10	40 40 Mid 150V Electrolytic	CEM-19
C-11	2-Gang Variable Cond. w. Drum	CV-5
C-11a, C-11b	Trimmer Condenser on Gang	C-11a, C-11b
L-1	B'cast Loop Antenna	LA-6
L-2	B'cast Oscillator Coil	L0-5
PC-51	Printed Circuit	CRP-6
PL-3	Printed Circuit	CRP-5
PL-3	Pilot Lamp GE 1490	PL-3
P-25	Volume Control 2 Megohms	P-25
P-26	Tone Control w. Switch 2 Megohms	P-26
R-1	22K ohms 1/2W	RC-223-2
R-2	2.2 Megohms 1/2W	RC-225-1
R-3	1 Megohm 1/2W	RC-105-2
R-4	470K ohms 1/2W	RC-474-2
R-5	150 ohms 1/2W	RC-151-1
R-6	220K ohms 1/2W	RC-224-2
R-7	1000 ohms 2W	RC-102-7
R-8	330 ohms 1W	RC-331-4
T-1, T-2	I.F. Transformer	LIF-14
T-132	Audio Output Transformer	T-132

CHASSIS RE-2A

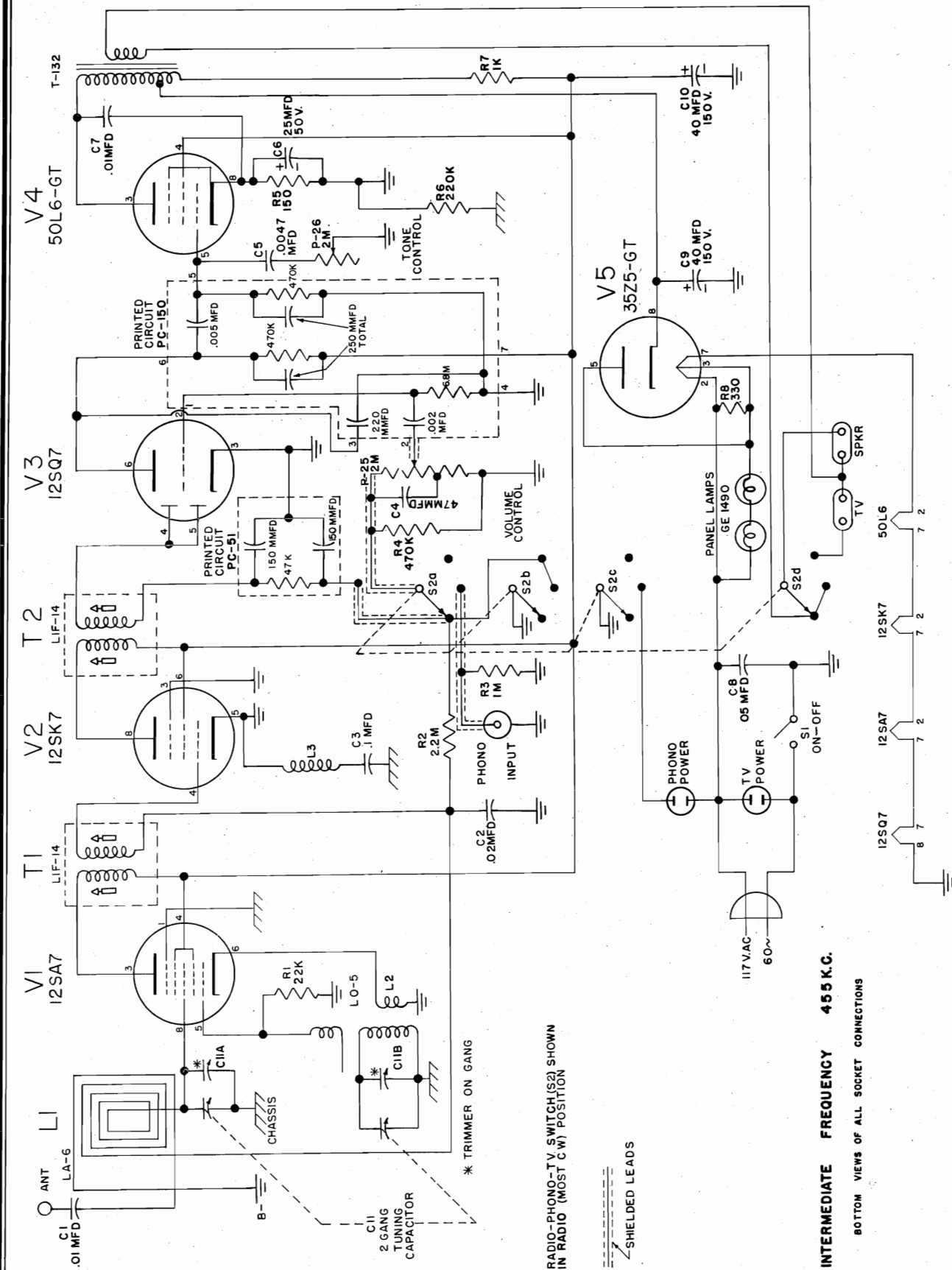

INTERMEDIATE FREQUENCY 455 K.C.

BOTTOM VIEWS OF ALL SOCKET CONNECTIONS

RADIO-PHONO-TV SWITCH (S2) SHOWN IN RADIO (MOST C.W.) POSITION

SHIELDED LEADS

* TRIMMER ON GANG

ALIGNMENT AND SERVICE DATA

Remove chassis from cabinet for alignment.

A Signal Generator is required having the following frequencies: 455 KC, 1400 KC, 1650 KC. An output meter should be connected across the speaker.

FIRST STEP: Connect the hot lead from the generator to the ANT. section of the gang condenser, through a .1 MFD condenser. The ground lead from the generator must be connected to the metal frame of the gang condenser. Turn the gang condenser to complete minimum capacity. Adjust the generator to 455KC and adjust the trimmers of the 1st and 2nd I.F. transformers until a maximum reading is noted on the output meter.

SECOND STEP: With the leads from the generator still connected in the same manner, adjust the Signal Generator to 1650 KC. The OSC. trimmer is located on the front of the chassis between the volume and tuning controls. Adjust this trimmer until the 1650 KC signal is tuned in.

THIRD STEP: Remove the hot lead of the generator from the ANT. section of the gang condenser. Adjust the Signal Generator to 1400 KC. Rotate the tuning control until this signal is tuned in. The ANT trimmer is located on the back of the loop antenna. Adjust this trimmer until a maximum reading is noted on the output meter. No further adjustment should be necessary, unless the set has been damaged, as the coils and condenser in this receiver have been specially handled at the factory to insure proper alignment at the lower frequencies.

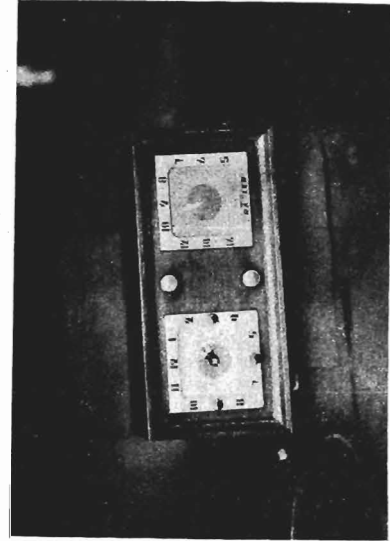
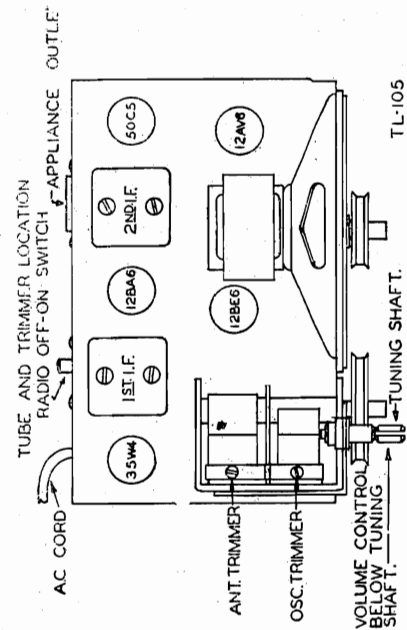

MODEL 5170

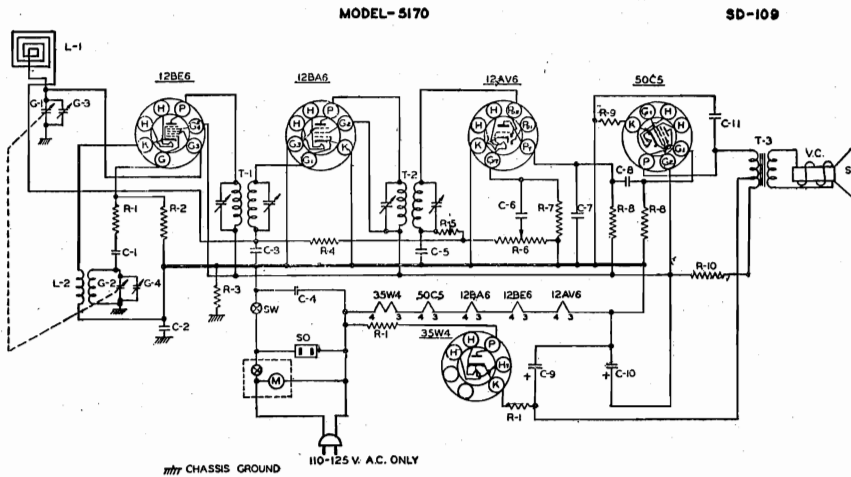
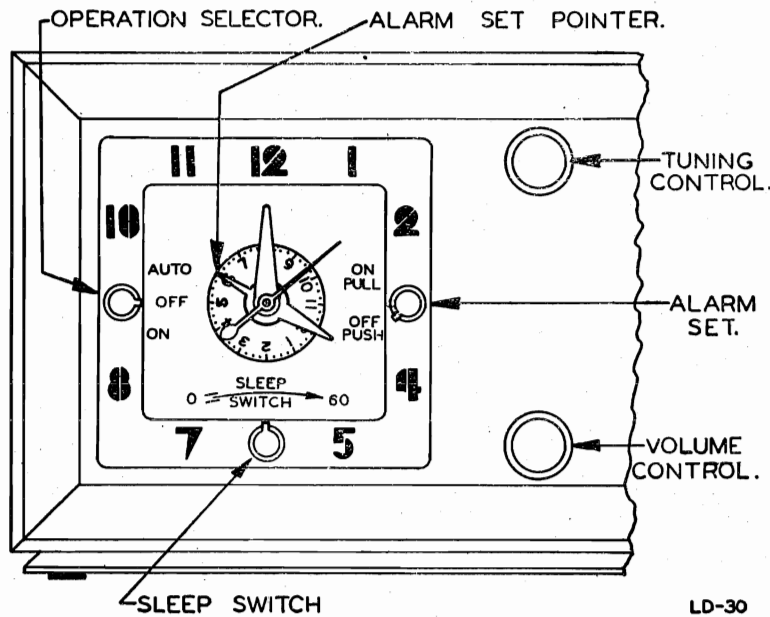
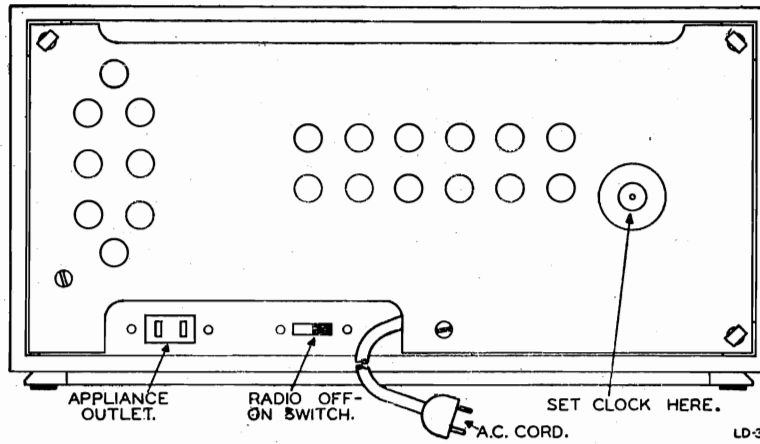

PART NO.	DESCRIPTION	PART NO.	DESCRIPTION	PART NO.	DESCRIPTION
IR-17	R-1 33 Ω RESISTOR 1/2W. 20%	MC-4	C-1 50MMFD. MICA CONDENSER.	SPK-19	S 4" P.M. SPEAKER
IR-9	R-2 22M Ω RESISTOR 1/2W. 20%	PC-8	C-2 1MFD. CONDENSER 400 V.	T-3	V.C. VOICE COIL
IR-20	R-3 220M Ω RESISTOR 1/2W. 20%	PC-2	C-3 .05MFD. CONDENSER 200 V.	T-3	OUTPUT TRANSFORMER
IR-23	R-4 33MEG. RESISTOR 1/2W. 20%	PC-5	C-4 .05MFD. CONDENSER 400 V.	L-1	L-1 LOOP ANT.
IR-10	R-5 47M Ω RESISTOR 1/2W. 20%	C-5	220MMFD.	L-2	OSC. COIL
VC-37	R-6 1MEG. VOLUME CONTROL.	MC-8	C-6 .002MFD.	CK-1	M ELECTRIC CLOCK
IR-13	R-7 2MEG. RESISTOR 1/2W. 20%	C-7	220MMFD.	SO	SO APPLIANCE SOCKET
IR-11	R-8 470K Ω RESISTOR 1/2W. 20%	C-8	.005MFD.	SW-9	SW SRST. RADIO ON-OFF SWITCH
IR-14	R-9 150 Ω RESISTOR 1/2W. 20%	EC-24	C-9 50 MFD. ELECTROLYTIC. 150 V.D.C.		
IR-42	R-10 1000 Ω RESISTOR 1 W. 10%	PC-10	C-10 50 MFD.		
		C-11	.005MFD. CONDENSER 400V.		
L1-6	T-1 INPUT I.F. TRANSFORMER	GC-5B	G-1 TUNING CONDENSER		
L1-7	T-2 OUTPUT I.F. TRANSFORMER		G-2		

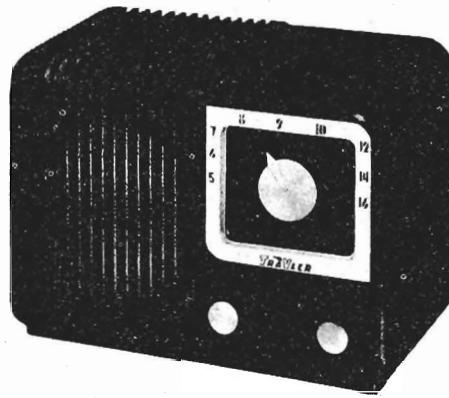

5171 Operating Instructions

POWER SOURCES: This receiver may be operated on alternating current (AC) of 110 to 125 volts at 60 cycles or on direct current (DC) of 110 to 125 volts. When used on DC, if the tubes light up but set does not play, reverse the cord plug in the power outlet.

CAUTION: Always predetermine voltage of power source. Never try to plug this receiver into a 220 volt line, as this will cause serious damage.

INSTALLATION: Unwind the power cord and plug into a convenient outlet. This receiver is equipped with a sensitive loop antenna and under ordinary conditions no external antenna would be required.

Due to the directional qualities of the loop antenna the reception of some stations may be improved by placing the receiver in different positions.

CONTROLS: Two knobs control the operation of this receiver. The left hand knob is used to turn set off and on. It is also used to control volume. Rotate knob to your right in a clockwise direction and a click will be heard. This turns receiver on. Allow about 30 seconds for tubes to heat up, then continue to rotate knob to your right to increase volume. The right hand knob is the station selector. Rotate this knob to right or left to locate your station. By mentally adding a zero to the numbers on the dial, the result will be read directly in kilocycles. To turn set off, turn left hand knob to your left in a counterclockwise direction as far as it will go and a click will be heard. The power switch will then be turned off.

MODEL-5171
TUBE AND TRIMMER LOCATION

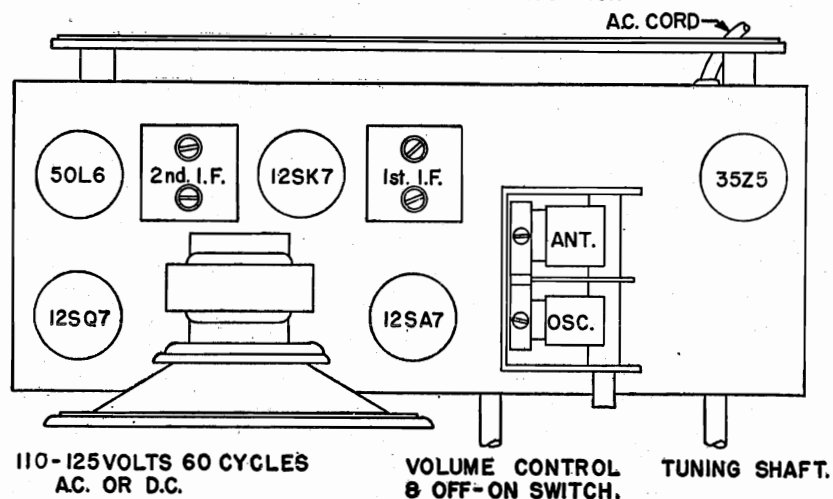

ALIGNMENT AND SERVICE DATA

Remove chassis from cabinet for alignment.

A Signal Generator is required having the following frequencies: 455 KC, 1400 KC, 1650 KC. An output meter should be connected across the speaker.

The volume control of the receiver should be turned to maximum during the I. F. and all subsequent alignment and the generator output as low as possible to prevent the A. V. C. from working and giving false readings.

FIRST STEP: Connect the hot lead from the generator to the ANT. section of the gang condenser through the .1 MFD. condenser. The ground lead from the generator must be connected to "B" minus under the chassis. Turn the gang condenser to complete minimum capacity. Set the generator to 455 KC. Adjust the trimmers of the first and second I. F. transformers until a maximum reading is noted on the output meter.

SECOND STEP: With the leads from the generator still connected in the same manner, adjust the Signal Generator to 1650 KC. Adjust the OSC. trimmer until the 1650 KC signal is tuned in. The gang condenser must be at complete minimum capacity for this adjustment.

THIRD STEP: Remove the generator leads from the gang condenser. Loosely couple the generator to the receiver loop by using a complete turn of wire. With the receiver and generator set at 1400 KC, increase the generator output. Adjust the ANT. trimmer until a maximum signal is noted on the output meter. No further adjustment should be made as the coils and gang condenser in this receiver have been specially handled at the factory to insure proper alignment at the lower frequencies.

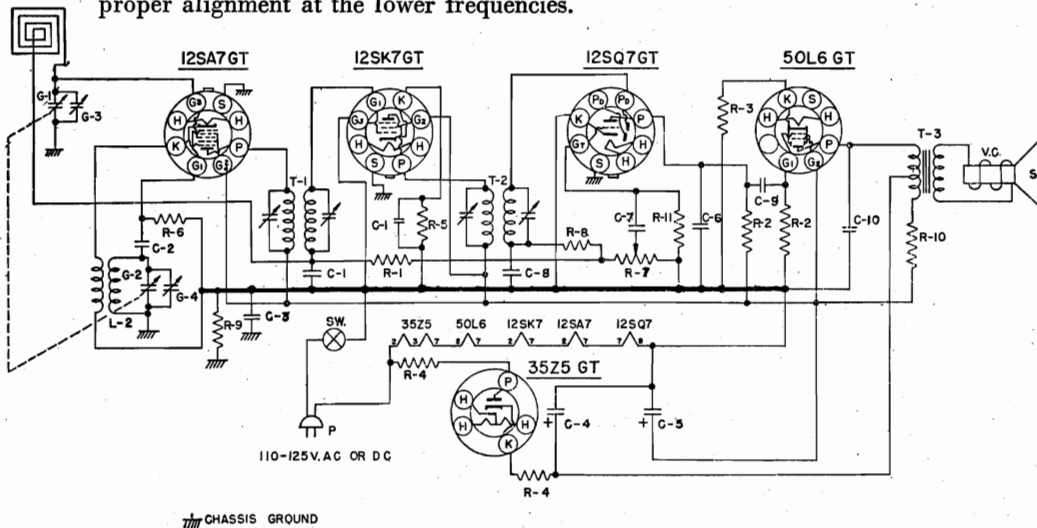

PART NO.	DESCRIPTION	PART NO.	DESCRIPTION	PART NO.	DESCRIPTION
1R-23	R-1 3.3 MEG. RESISTOR 1/2W 20%	G-3	ANT. TRIMMER CONDENSER.	LL-28	L-1 LOOP ANT.
1R-11	R-2 470M ^Ω RESISTOR 1/2W 20%	G-4	OSC. TRIMMER CONDENSER	LO-13	L-2 OSC. COIL.
1R-14	R-3 150 ^Ω RESISTOR 1/2 W 20%	PC-2	C-1 .05 MFD. CONDENSER 200 V.	LI-6	T-1 INPUT I.F. TRANSFORMER
1R-17	R-4 33 ^Ω RESISTOR 1/2 W 20%	MC-4	C-2 .50 MMFD. MICA CONDENSER.	LI-7	T-2 OUTPUT I.F. TRANSFORMER
1R-21	R-5 330 ^Ω RESISTOR 1/2 W 20%	PC-9	C-3 J MFD. CONDENSER 400 V.	T-3	T-3 SPK. OUTPUT TRANSFORMER
1R-9	R-6 22M ^Ω RESISTOR 1/2 W 20%	EO-24	C-4 .50MFD. ELECTROLYTIC 150 V.	SPK-19	V.C. VOICE COIL
VC-38	R-7 1 MEG. VOLUME CONTROL.		C-5 .50MFD. ELECTROLYTIC 150 V.	S	P.M. SPEAKER
1R-10	R-8 47M ^Ω RESISTOR 1/2 W 20%		C-6 .220MMFD.	CO-1	P LINE CORD.
1R-20	R-9 220M ^Ω RESISTOR 1/2 W 20%	MC-B	C-7 .002MFD.	SW	AC SWITCH ON VOLUME CONTROL
1R-42	R-10 1000 ^Ω RESISTOR 1W 20%		C-8 .220MMFD. HERLEC		
1R-13	R-11 2.2 MEG. RESISTOR 1/2 20%	PC-10	C-9 .005 MFD.		
GC-58	G-1 G-2 GANG CONDENSER.		C-10 .005MFD. CONDENSER 400V.		

FREQUENCY RANGE: 535 KC. TO 1630 KC.

OPERATING INSTRUCTIONS

POWER SOURCES: This receiver operates from its own enclosed batteries and requires no external power source.

CONTROLS: Two controls are provided for the operation of this receiver and are located on the left and right ends of the front panel of the cabinet.

VOLUME CONTROL AND "OFF-ON SWITCH": The right hand knob is the volume control and is also used to turn the receiver "OFF" or "ON". Rotate this knob upward and a click will be heard, which indicates that the receiver is "ON". Turn this knob further upward to increase volume, or downward to decrease volume.

STATION SELECTOR: The left hand knob is the station selector or tuning control. Rotate this knob upward or downward to select your desired station. By mentally adding zeroes to the figures on the dial the result will be read directly in kilocycles i.e., 14 plus 00 equals 1400 KC, or 65 plus 0 equals 650 KC.

Rotate the tuning knob until the proper station has been selected, then adjust the volume control to the desired level.

ANTENNA: This receiver is equipped with a sensitive Ferramic Rod antenna and requires no external antenna wire. However, due to the directional qualities of the antenna, some stations may appear to be weak in reception. This condition may be remedied by rotating, or changing the position, of the receiver.

CAUTION: When you have finished listening to the receiver, turn the volume control all the way downward until a click is heard and the word "OFF" appears in the window opening of the cabinet. This will indicate that the switch is turned off. If the switch is left on for long periods of time the batteries will be used up and the receiver will not play. Remember that conservative use of the receiver will give many hours of enjoyment and economical operation.

BATTERY SERVICING

(See Fig. No. 1)

To replace the batteries in this receiver:

Remove the back by pressing downward along the top of the back in the vicinity of the metal handle loops, and at the same time, pull backward on the cabinet back, to disengage the locking catches along the inside edge of the back.

To replace the "A" batteries, lift the old batteries straight up. When inserting fresh batteries, make sure that the metal cap on the top of the batteries face outward toward the ends of the cabinet. (See Fig. No. 1) Place the metal cap against the end connectors, then push the batteries straight down into place.

To replace the "B" battery, disconnect the snap fastener connector. Replace with a fresh battery and snap the connector into place. Replace the battery in the cabinet as shown in Fig. No. 1, making sure that the connector end faces the speaker.

After the batteries have been installed, replace the back, making sure that the catches on the bottom edge of the back fit into the slots along the bottom edge of the cabinet and then swing the back up as if it were on a hinge until it begins to enter the cabinet at the top. Then push downward along the top edge of the back, at the same time pressing it inward, to reengage the top catches.

CAUTION: If the batteries in the receiver wear out from use and the receiver refuses to operate, make sure that the volume control is turned all the way downward, in "OFF" position, until the batteries can be replaced. If the switch is left in the "ON" position, this will cause the battery cells to burst and they will leak into the receiver which may ruin the component parts.

BATTERY LIFE AND REPLACEMENT

The specified batteries are especially designed for this receiver and will yield balanced life under normal conditions of service.

To insure maximum service—all batteries should be replaced at the same time.

Types required: 2-1½ Volt "A" 1-67½ Volt "B".

Manufacturers Types and Numbers

SIZE "G" - "A" BATTERY
 EVEREADY - NO. 964
 BURGESS - NO. 21R
 R C A - NO. VS236
 RAY-O-VAC - NO. 8R

67½ VOLT "B" BATTERY
 EVEREADY - NO. 477
 BURGESS - NO. P45
 R C A - NO. VS216
 RAY-O-VAC - NO. 946

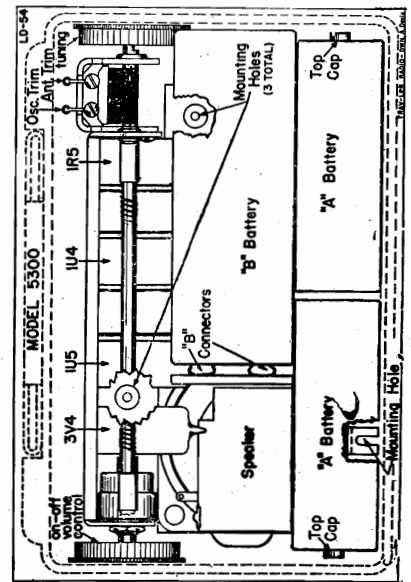

Fig. 1

ALIGNMENT AND SERVICE DATA

Refer to Fig. No. 1 for location of mounting screws, and remove the chassis from the cabinet for alignment. A signal generator is required having the following frequencies: 455 KC, 1400 KC, and 1630 KC. An output meter should be connected across the speaker.

FIRST STEP: Connect the hot lead from the generator to the ANT. section of the gang condenser, through a .1 MFD. condenser. The ground lead from the generator may be connected to any spot on the metal chassis. Turn the gang condenser to complete minimum capacity. Set the generator to 455 KC. Adjust the movable iron cores in the IF cans. The IF adjustments are made in the top and in the bottom of the can nearest to the gang condenser. The remaining IF can, farthest from the gang condenser, is adjusted only from the top. Adjust the cores until a maximum reading is noted on the output meter.

The volume control of the receiver should be turned to maximum during the IF and all subsequent alignment and the generator output as low as possible to prevent the AVC from working and giving false readings.

SECOND STEP: With the leads from the generator still connected as in IF alignment, adjust the generator to 1630 KC. Make sure that the gang condenser is turned to complete minimum capacity. Adjust the generator to 1630 KC. and adjust the oscillator trimmer of the receiver until the signal is tuned in. Next, turn the gang condenser to complete maximum capacity. Adjust the generator to 535 KC., then adjust the iron core in the end of the oscillator coil until the signal is tuned in. It may be well to recheck the 1630 KC. setting to make sure that the adjustment of the iron core has not shifted the frequency.

THIRD STEP: Remove the generator leads from the gang condenser and the chassis. Loosely couple the generator to the antenna by laying the hot generator lead near the antenna rod. Set the generator at 1400 KC. and tune in the 1400 KC. signal on the receiver. Adjust the ANT. trimmer until a maximum signal is noted on the output meter.

No further adjustment should be necessary as the coils and gang condenser in this receiver have been specially handled at the factory to insure proper alignment at the lower frequencies.

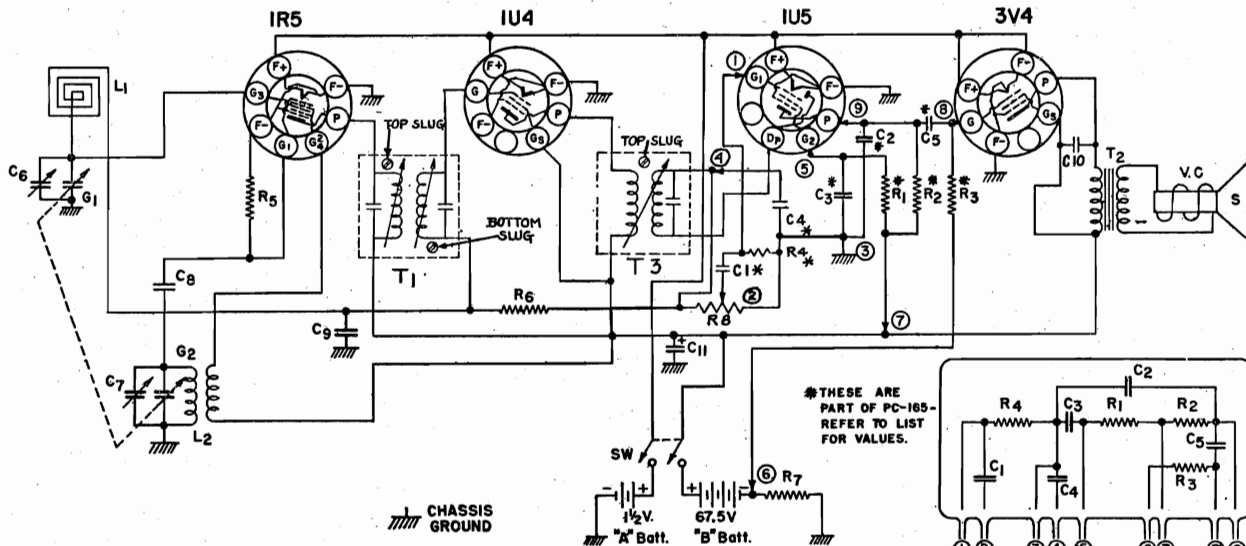

PART NO.	SYMBOL	DESCRIPTION	PART NO.	SYMBOL	DESCRIPTION
	C6	ANTENNA TRIMMER ON GANG.	LL-30	L1	LOOP ANTENNA.
CC-5	C7	OSC. TRIMMER ON GANG.	LO-18	L2	OSC. COIL.
CC-3	C8	100 mfd. CERAMIC CONDENSER.	L1-10	T1	I.F. TRANSFORMER INPUT.
CC-20	C9	.005 mfd. CERAMIC CONDENSER.	SPK-21	SW	D.P.S.T SWITCH (Part of Vol. control)
EC-11	C10	.0015 mfd. CERAMIC CONDENSER.		T2	SPEAKER TRANSFORMER.
IR-20	C11	10 mfd. 70V. ELECTROLYTIC COND.		VC	VOICE COIL.
IR-23	R5	220K. ±20% 1/2 Watt. RESISTOR.		S	P.M. SPEAKER
IR-39	R6	3.3 meg. ±20% 1/2 Watt. RESISTOR.	LI-11	T3	I.F. TRANSFORMER OUTPUT
VC-40	R7	620 Ω ±10% 1/2 Watt. RESISTOR.	TU-40		RADIO TUBES IR5, IU4, IU5, 3V4
GC-12	R8	1 meg. VOLUME CONTROL.			
	G1, G2	GANG CONDENSER			

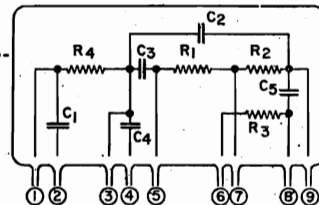

PC-165 WIRING DIAGRAM

- R1 = 4.7 Meg.
- R2 = 1.0 Meg.
- R3 = 3.3 Meg.
- R4 = 10 Meg.
- C1 = 2000 mfd.
- C2 = 150 mfd.
- C3 = .01 mfd.
- C4 = 150 mfd.
- C5 = 5000 mfd.

TUNING RANGE — 540 KC to 1650 KC

POWER SOURCES: This receiver is designed for operation on either an external power source or on the enclosed batteries.

AC OR DC OPERATION: This receiver may be operated on 50 to 60 cycle, 110 to 125 volt AC current or 110 to 125 DC current.

CAUTION: Never plug this receiver into a 220 volt line as this will seriously damage the component parts which have been designed for 110 to 125 volt operation only.

To operate on AC or DC open the small door at the right in the back of the cabinet. Pull out the power cord and plug into a convenient outlet of the proper voltage and current. Follow instructions under "Controls."

To operate on the enclosed batteries, follow instructions under "Controls."
ANTENNA: This receiver is equipped with a sensitive loop antenna and requires no external antenna wire. However, due to the directional qualities of the loop some stations may appear to be weak in reception. This condition may be remedied by rotating or changing the position of the receiver.

CONTROLS: This receiver has three control knobs which are located on the front panel of the cabinet.

STATION SELECTOR KNOB: The center knob is the station selector. Rotate this knob to the right or left to select your desired station. The dial scale is calibrated in kilocycles. By mentally adding a zero to the numbers on the scale, the result will be read directly in (KC) kilocycles. (i.e., 60 plus 0 equals 600 KC or 140 plus 0 equals 1400 KC).

POWER SELECTOR SWITCH: The right hand knob is the power selector. It has three positions which are indicated on the front panel. The extreme left hand position is the "OFF" position. The small dot on this knob must point to "OFF" when the receiver is not in use. The center position is "AC-DC" and is used when it is desired to operate the receiver from a power line source. The extreme right hand position is "BATT" and is used when it is desired to operate on the enclosed batteries.

AC OPERATION: When an AC power source is used, set the power selector knob to "AC-DC" after the power cord has been plugged into a convenient outlet. The receiver is now ready for operation.

DC OPERATION: If the receiver does not operate after a few seconds, reverse the power cord plug in the outlet and it will operate properly.

BATTERY OPERATION: The power cord is not used for battery operation and may be hanked and put back in the cabinet. Set the power control knob to "BATT" and the receiver is ready for operation on the enclosed batteries.

CAUTION: When the receiver is not in use, the power selector knob must be turned to "OFF." If the knob is allowed to remain in "BATT" position, the batteries will be in use constantly. The volume control does not control the batteries and they are still in operation even though the volume control is turned all the way off.

VOLUME CONTROL: The left hand knob is the volume control. After the power selector knob has been properly set and the receiver is in operation, rotate the volume control knob to the right to increase volume or to the left to decrease volume.

BATTERY SUPPLIERS

The batteries for this receiver may be purchased from any reliable dealer. For proper operation this receiver requires two "A" batteries and one "B" battery.

The "A" batteries are size "D" flashlight cells and are made by all battery manufacturers.

The "B" battery is a 67½ volt battery, either standard size or the new long life series as made by the following manufacturers.

	Standard Type	Long Life Type
Eveready	67½ vlt. #467	#477
Burgess	67½ vlt. #XX45	#P45
RCA	67½ vlt. #VSO16	#VS216
Ray-O-Vac	67½ vlt. #4367	#946

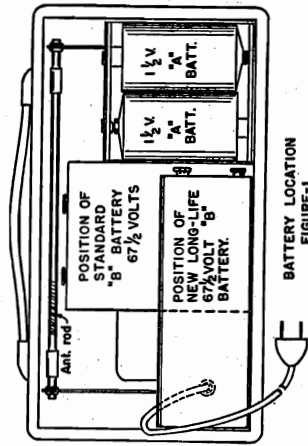

BATTERY SERVICING

(See Fig. No. 1)

To replace the batteries in this receiver. Remove the back.

To the right, looking into the rear of the cabinet is the "A" or flashlight battery container. To the left is the "B" or 67½ volt battery.

To replace the "A" batteries, pull the old batteries out of the container. Replace with fresh batteries, making sure the batteries are inserted according to the diagram on the inside of the container.

To replace the "B" battery, disconnect the snap fastener connectors. Replace with a fresh battery and snap the connectors into place. Replace the battery in the cabinet as shown in Fig. No. 1, making sure that the connector end faces the top of the cabinet.

After the batteries have been installed, replace the back, making sure that the two washers in the bottom of the back fit into the slot near the bottom edge of the cabinet.

ALIGNMENT AND SERVICE DATA

(See Fig. No. 2 For Trimmer Location)

Remove chassis from cabinet for alignment.

A Signal Generator is required having the following frequencies: 455 KC, 1400 KC, 1650 KC. An output meter should be connected across the speaker.

The volume control of the receiver should be turned to maximum during the I. F. and all subsequent alignment and the generator output as low as possible to prevent the A. V. C. from working and giving false readings.

FIRST STEP: Connect the hot lead from the generator to the ANT. Section of the gang condenser through a .1 MFD. condenser. The ground lead from the generator must be connected to "B" minus under the chassis. Turn the gang condenser to complete minimum capacity. Set the generator to 455 KC. Adjust the movable iron cores in the IF cans. These IF adjustments are made in the top and in the bottom of the can under the chassis. Adjust the cores until a maximum reading is noted on the output meter.

SECOND STEP: With the leads from the generator still connected in the same manner, adjust the Signal Generator to 1650 KC. Adjust the OSC. trimmer until the 1650 KC signal is tuned in. The gang condenser must be at complete minimum capacity for this adjustment.

THIRD STEP: Remove the generator leads from the gang condenser and replace the chassis in the cabinet. Loosely couple the generator to the receiver loop by making a complete turn of wire over the outside of the cabinet. With the receiver and generator set at 1400 KC, increase the generator output. Adjust the ANT. trimmer through the hole which is provided in the end of the cabinet until a maximum signal is noted on the output meter. The ANT. trimmer hole in the side of the cabinet is covered by a small plug button. Replace this button after adjustment has been made. No further adjustment should be made as the coils and gang condenser in this receiver have been specially handled at the factory to insure proper alignment at the lower frequencies.

PART NO.	DESCRIPTION
IR-20	R-1 220M RESISTOR 1/2W 20 X
IR-37	10M RESISTOR 1/2W 20 X
IR-37	33M RESISTOR 1/2W 20 X
IR-37	82M RESISTOR 1/2W 10 X
VC16	IMCC VOLUME CONTROL
IR-33	R-6 270 RESISTOR 1/2W 10 X
IR-33	R-7 620 RESISTOR 1/2W 20 X
IR-33	R-8 10MEG RESISTOR 1/2W 20 X
IR-33	R-9 3MEG RESISTOR 1/2W 20 X
IR-33	R-10 2MEG RESISTOR 1/2W 20 X
IR-33	R-11 350 RESISTOR 1/2W 20 X
IR-33	R-12 350 RESISTOR 1/2W 20 X
IR-33	R-13 350 RESISTOR 1/2W 20 X
IR-33	R-14 350 RESISTOR 1/2W 20 X
IR-33	R-15 350 RESISTOR 1/2W 20 X
IR-33	R-16 350 RESISTOR 1/2W 20 X
IR-33	R-17 350 RESISTOR 1/2W 20 X
IR-33	R-18 350 RESISTOR 1/2W 20 X
IR-33	R-19 350 RESISTOR 1/2W 20 X
IR-33	R-20 350 RESISTOR 1/2W 20 X
IR-33	R-21 350 RESISTOR 1/2W 20 X
IR-33	R-22 350 RESISTOR 1/2W 20 X
IR-33	R-23 350 RESISTOR 1/2W 20 X
IR-33	R-24 350 RESISTOR 1/2W 20 X
IR-33	R-25 350 RESISTOR 1/2W 20 X
IR-33	R-26 350 RESISTOR 1/2W 20 X
IR-33	R-27 350 RESISTOR 1/2W 20 X
IR-33	R-28 350 RESISTOR 1/2W 20 X
IR-33	R-29 350 RESISTOR 1/2W 20 X
IR-33	R-30 350 RESISTOR 1/2W 20 X
IR-33	R-31 350 RESISTOR 1/2W 20 X
IR-33	R-32 350 RESISTOR 1/2W 20 X
IR-33	R-33 350 RESISTOR 1/2W 20 X
IR-33	R-34 350 RESISTOR 1/2W 20 X
IR-33	R-35 350 RESISTOR 1/2W 20 X
IR-33	R-36 350 RESISTOR 1/2W 20 X
IR-33	R-37 350 RESISTOR 1/2W 20 X
IR-33	R-38 350 RESISTOR 1/2W 20 X
IR-33	R-39 350 RESISTOR 1/2W 20 X
IR-33	R-40 350 RESISTOR 1/2W 20 X
IR-33	R-41 350 RESISTOR 1/2W 20 X
IR-33	R-42 350 RESISTOR 1/2W 20 X
IR-33	R-43 350 RESISTOR 1/2W 20 X
IR-33	R-44 350 RESISTOR 1/2W 20 X
IR-33	R-45 350 RESISTOR 1/2W 20 X
IR-33	R-46 350 RESISTOR 1/2W 20 X
IR-33	R-47 350 RESISTOR 1/2W 20 X
IR-33	R-48 350 RESISTOR 1/2W 20 X
IR-33	R-49 350 RESISTOR 1/2W 20 X
IR-33	R-50 350 RESISTOR 1/2W 20 X
IR-33	R-51 350 RESISTOR 1/2W 20 X
IR-33	R-52 350 RESISTOR 1/2W 20 X
IR-33	R-53 350 RESISTOR 1/2W 20 X
IR-33	R-54 350 RESISTOR 1/2W 20 X
IR-33	R-55 350 RESISTOR 1/2W 20 X
IR-33	R-56 350 RESISTOR 1/2W 20 X
IR-33	R-57 350 RESISTOR 1/2W 20 X
IR-33	R-58 350 RESISTOR 1/2W 20 X
IR-33	R-59 350 RESISTOR 1/2W 20 X
IR-33	R-60 350 RESISTOR 1/2W 20 X
IR-33	R-61 350 RESISTOR 1/2W 20 X
IR-33	R-62 350 RESISTOR 1/2W 20 X
IR-33	R-63 350 RESISTOR 1/2W 20 X
IR-33	R-64 350 RESISTOR 1/2W 20 X
IR-33	R-65 350 RESISTOR 1/2W 20 X
IR-33	R-66 350 RESISTOR 1/2W 20 X
IR-33	R-67 350 RESISTOR 1/2W 20 X
IR-33	R-68 350 RESISTOR 1/2W 20 X
IR-33	R-69 350 RESISTOR 1/2W 20 X
IR-33	R-70 350 RESISTOR 1/2W 20 X
IR-33	R-71 350 RESISTOR 1/2W 20 X
IR-33	R-72 350 RESISTOR 1/2W 20 X
IR-33	R-73 350 RESISTOR 1/2W 20 X
IR-33	R-74 350 RESISTOR 1/2W 20 X
IR-33	R-75 350 RESISTOR 1/2W 20 X
IR-33	R-76 350 RESISTOR 1/2W 20 X
IR-33	R-77 350 RESISTOR 1/2W 20 X
IR-33	R-78 350 RESISTOR 1/2W 20 X
IR-33	R-79 350 RESISTOR 1/2W 20 X
IR-33	R-80 350 RESISTOR 1/2W 20 X
IR-33	R-81 350 RESISTOR 1/2W 20 X
IR-33	R-82 350 RESISTOR 1/2W 20 X
IR-33	R-83 350 RESISTOR 1/2W 20 X
IR-33	R-84 350 RESISTOR 1/2W 20 X
IR-33	R-85 350 RESISTOR 1/2W 20 X
IR-33	R-86 350 RESISTOR 1/2W 20 X
IR-33	R-87 350 RESISTOR 1/2W 20 X
IR-33	R-88 350 RESISTOR 1/2W 20 X
IR-33	R-89 350 RESISTOR 1/2W 20 X
IR-33	R-90 350 RESISTOR 1/2W 20 X
IR-33	R-91 350 RESISTOR 1/2W 20 X
IR-33	R-92 350 RESISTOR 1/2W 20 X
IR-33	R-93 350 RESISTOR 1/2W 20 X
IR-33	R-94 350 RESISTOR 1/2W 20 X
IR-33	R-95 350 RESISTOR 1/2W 20 X
IR-33	R-96 350 RESISTOR 1/2W 20 X
IR-33	R-97 350 RESISTOR 1/2W 20 X
IR-33	R-98 350 RESISTOR 1/2W 20 X
IR-33	R-99 350 RESISTOR 1/2W 20 X
IR-33	R-100 350 RESISTOR 1/2W 20 X
IR-33	R-101 350 RESISTOR 1/2W 20 X
IR-33	R-102 350 RESISTOR 1/2W 20 X
IR-33	R-103 350 RESISTOR 1/2W 20 X
IR-33	R-104 350 RESISTOR 1/2W 20 X
IR-33	R-105 350 RESISTOR 1/2W 20 X
IR-33	R-106 350 RESISTOR 1/2W 20 X
IR-33	R-107 350 RESISTOR 1/2W 20 X
IR-33	R-108 350 RESISTOR 1/2W 20 X
IR-33	R-109 350 RESISTOR 1/2W 20 X
IR-33	R-110 350 RESISTOR 1/2W 20 X
IR-33	R-111 350 RESISTOR 1/2W 20 X
IR-33	R-112 350 RESISTOR 1/2W 20 X
IR-33	R-113 350 RESISTOR 1/2W 20 X
IR-33	R-114 350 RESISTOR 1/2W 20 X
IR-33	R-115 350 RESISTOR 1/2W 20 X
IR-33	R-116 350 RESISTOR 1/2W 20 X
IR-33	R-117 350 RESISTOR 1/2W 20 X
IR-33	R-118 350 RESISTOR 1/2W 20 X
IR-33	R-119 350 RESISTOR 1/2W 20 X
IR-33	R-120 350 RESISTOR 1/2W 20 X
IR-33	R-121 350 RESISTOR 1/2W 20 X
IR-33	R-122 350 RESISTOR 1/2W 20 X
IR-33	R-123 350 RESISTOR 1/2W 20 X
IR-33	R-124 350 RESISTOR 1/2W 20 X
IR-33	R-125 350 RESISTOR 1/2W 20 X
IR-33	R-126 350 RESISTOR 1/2W 20 X
IR-33	R-127 350 RESISTOR 1/2W 20 X
IR-33	R-128 350 RESISTOR 1/2W 20 X
IR-33	R-129 350 RESISTOR 1/2W 20 X
IR-33	R-130 350 RESISTOR 1/2W 20 X
IR-33	R-131 350 RESISTOR 1/2W 20 X
IR-33	R-132 350 RESISTOR 1/2W 20 X
IR-33	R-133 350 RESISTOR 1/2W 20 X
IR-33	R-134 350 RESISTOR 1/2W 20 X
IR-33	R-135 350 RESISTOR 1/2W 20 X
IR-33	R-136 350 RESISTOR 1/2W 20 X
IR-33	R-137 350 RESISTOR 1/2W 20 X
IR-33	R-138 350 RESISTOR 1/2W 20 X
IR-33	R-139 350 RESISTOR 1/2W 20 X
IR-33	R-140 350 RESISTOR 1/2W 20 X
IR-33	R-141 350 RESISTOR 1/2W 20 X
IR-33	R-142 350 RESISTOR 1/2W 20 X
IR-33	R-143 350 RESISTOR 1/2W 20 X
IR-33	R-144 350 RESISTOR 1/2W 20 X
IR-33	R-145 350 RESISTOR 1/2W 20 X
IR-33	R-146 350 RESISTOR 1/2W 20 X
IR-33	R-147 350 RESISTOR 1/2W 20 X
IR-33	R-148 350 RESISTOR 1/2W 20 X
IR-33	R-149 350 RESISTOR 1/2W 20 X
IR-33	R-150 350 RESISTOR 1/2W 20 X
IR-33	R-151 350 RESISTOR 1/2W 20 X
IR-33	R-152 350 RESISTOR 1/2W 20 X
IR-33	R-153 350 RESISTOR 1/2W 20 X
IR-33	R-154 350 RESISTOR 1/2W 20 X
IR-33	R-155 350 RESISTOR 1/2W 20 X
IR-33	R-156 350 RESISTOR 1/2W 20 X
IR-33	R-157 350 RESISTOR 1/2W 20 X
IR-33	R-158 350 RESISTOR 1/2W 20 X
IR-33	R-159 350 RESISTOR 1/2W 20 X
IR-33	R-160 350 RESISTOR 1/2W 20 X
IR-33	R-161 350 RESISTOR 1/2W 20 X
IR-33	R-162 350 RESISTOR 1/2W 20 X
IR-33	R-163 350 RESISTOR 1/2W 20 X
IR-33	R-164 350 RESISTOR 1/2W 20 X
IR-33	R-165 350 RESISTOR 1/2W 20 X
IR-33	R-166 350 RESISTOR 1/2W 20 X
IR-33	R-167 350 RESISTOR 1/2W 20 X
IR-33	R-168 350 RESISTOR 1/2W 20 X
IR-33	R-169 350 RESISTOR 1/2W 20 X
IR-33	R-170 350 RESISTOR 1/2W 20 X
IR-33	R-171 350 RESISTOR 1/2W 20 X
IR-33	R-172 350 RESISTOR 1/2W 20 X
IR-33	R-173 350 RESISTOR 1/2W 20 X
IR-33	R-174 350 RESISTOR 1/2W 20 X
IR-33	R-175 350 RESISTOR 1/2W 20 X
IR-33	R-176 350 RESISTOR 1/2W 20 X
IR-33	R-177 350 RESISTOR 1/2W 20 X
IR-33	R-178 350 RESISTOR 1/2W 20 X
IR-33	R-179 350 RESISTOR 1/2W 20 X
IR-33	R-180 350 RESISTOR 1/2W 20 X
IR-33	R-181 350 RESISTOR 1/2W 20 X
IR-33	R-182 350 RESISTOR 1/2W 20 X
IR-33	R-183 350 RESISTOR 1/2W 20 X
IR-33	R-184 350 RESISTOR 1/2W 20 X
IR-33	R-185 350 RESISTOR 1/2W 20 X
IR-33	R-186 350 RESISTOR 1/2W 20 X
IR-33	R-187 350 RESISTOR 1/2W 20 X
IR-33	R-188 350 RESISTOR 1/2W 20 X
IR-33	R-189 350 RESISTOR 1/2W 20 X
IR-33	R-190 350 RESISTOR 1/2W 20 X
IR-33	R-191 350 RESISTOR 1/2W 20 X
IR-33	R-192 350 RESISTOR 1/2W 20 X
IR-33	R-193 350 RESISTOR 1/2W 20 X
IR-33	R-194 350 RESISTOR 1/2W 20 X
IR-33	R-195 350 RESISTOR 1/2W 20 X
IR-33	R-196 350 RESISTOR 1/2W 20 X
IR-33	R-197 350 RESISTOR 1/2W 20 X
IR-33	R-198 350 RESISTOR 1/2W 20 X
IR-33	R-199 350 RESISTOR 1/2W 20 X
IR-33	R-200 350 RESISTOR 1/2W 20 X
IR-33	R-201 350 RESISTOR 1/2W 20 X
IR-33	R-202 350 RESISTOR 1/2W 20 X
IR-33	R-203 350 RESISTOR 1/2W 20 X
IR-33	R-204 350 RESISTOR 1/2W 20 X
IR-33	R-205 350 RESISTOR 1/2W 20 X
IR-33	R-206 350 RESISTOR 1/2W 20 X
IR-33	R-207 350 RESISTOR 1/2W 20 X
IR-33	R-208 350 RESISTOR 1/2W 20 X
IR-33	R-209 350 RESISTOR 1/2W 20 X
IR-33	R-210 350 RESISTOR 1/2W 20 X
IR-33	R-211 350 RESISTOR 1/2W 20 X
IR-33	R-212 350 RESISTOR 1/2W 20 X
IR-33	R-213 350 RESISTOR 1/2W 20 X
IR-33	R-214 350 RESISTOR 1/2W 20 X
IR-33	R-215 350 RESISTOR 1/2W 20 X
IR-33	R-216 350 RESISTOR 1/2W 20 X
IR-33	R-217 350 RESISTOR 1/2W 20 X
IR-33	R-218 350 RESISTOR 1/2W 20 X
IR-33	R-219 350 RESISTOR 1/2W 20 X
IR-33	R-220 350 RESISTOR 1/2W 20 X
IR-33	R-221 350 RESISTOR 1/2W 20 X
IR-33	R-222 350 RESISTOR 1/2W 20 X
IR-33	R-223 350 RESISTOR 1/2W 20 X
IR-33	R-224 350 RESISTOR 1/2W 20 X
IR-33	R-225 350 RESISTOR 1/2W 20 X
IR-33	R-226 350 RESISTOR 1/2W 20 X
IR-33	R-227 350 RESISTOR 1/2W 20 X
IR-33	R-228 350 RESISTOR 1/2W 20 X
IR-33	R-229 350 RESISTOR 1/2W 20 X
IR-33	R-230 350 RESISTOR 1/2W 20 X
IR-33	R-231 350 RESISTOR 1/2W 20 X
IR-33	R-232 350 RESISTOR 1/2W 20 X
IR-33	R-233 350 RESISTOR 1/2W 20 X
IR-33	R-234 350 RESISTOR 1/2W 20 X
IR-33	R-235 350 RESISTOR 1/2W 20 X
IR-33	R-236 350 RESISTOR 1/2W 20 X
IR-33	R-237 350 RESISTOR 1/2W 20 X
IR-33	R-238 350 RESISTOR 1/2W 20 X
IR-33	R-239 350 RESISTOR 1/2W 20 X
IR-33	R-240 350 RESISTOR 1/2W 20 X
IR-33	R-241 350 RESISTOR 1/2W 20 X
IR-33	R-242 350 RESISTOR 1/2W 20 X
IR-33	R-243 350 RESISTOR 1/2W 20 X
IR-33	R-244 350 RESISTOR 1/2W 20 X
IR-33	R-245 350 RESISTOR 1/2W 20 X
IR-33	R-246 350 RESISTOR 1/2W 20 X
IR-33	R-247 350 RESISTOR 1/2W 20 X
IR-33	R-248 350 RESISTOR 1/2W 20 X
IR-33	R-249 350 RESISTOR 1/2W 20 X
IR-33	R-250 350 RESISTOR 1/2W 20 X
IR-33	R-251 350 RESISTOR 1/2W 20 X
IR-33	R-252 350 RESISTOR 1/2W 20 X
IR-33	R-253 350 RESISTOR 1/2W 20 X
IR-33	R-254 350 RESISTOR 1/2W 20 X
IR-33	R-255 350 RESISTOR 1/2W 20 X
IR-33	R-256 350 RESISTOR 1/2W 20 X
IR-33	R-257 350 RESISTOR 1/2W 20 X
IR-33	R-258 350 RESISTOR 1/2W 20 X
IR-33	R-259 350 RESISTOR 1/2W 20 X
IR-33	R-260 350 RESISTOR 1/2W 20 X
IR-33	R-261 350 RESISTOR 1/2W 20 X
IR-33	R-262 350 RESISTOR 1/2W 20 X
IR-33	R-263 350 RESISTOR 1/2W 20 X
IR-33	R-264 350 RESISTOR 1/2W 20 X
IR-33	R-265 350 RESISTOR 1/2W 20 X
IR-33	R-266 350 RESISTOR 1/2W 20 X
IR-33	R-267 350 RESISTOR 1/2W 20 X
IR-33	R-268 350 RESISTOR 1/2W 20 X
IR-33	R-269 350 RESISTOR 1/2W 20 X
IR-33	R-270 350 RESISTOR 1/2W 20 X
IR-33	R-271 350 RESISTOR 1/2W 20 X

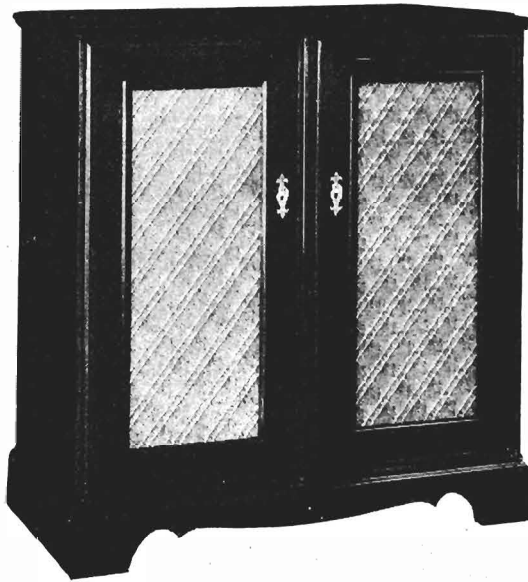

ELECTRICAL SPECIFICATIONS (Cont.)

Sensitivity.....AM—5 microvolts (average) for 100 milliwatts output
 FM—20 microvolts (average) for 30 db quieting

Amplifier Frequency Response.....20 to 20,000 CPS

Power Output.....12.5 watts maximum
 12 watts 10% distortion

Loud Speaker.....The single unit coaxial, dual cone Electro-Voice SP-12-B 12-inch full range speaker, with 16-oz. Alnico-V Magnet, gives smooth response (30 through 13,000 cycles). The 5 cu. ft. tone chamber is specially designed for optimum speaker performance. Other features are a 2-inch aluminum voice coil and a wide dispersion high frequency radiator cone. The voice coil impedance is 8-ohms 400-cycles.

Record Changer.....One of the newest and best high fidelity units available, the VM 935 High Fidelity record changer uses a resonance-free die cast aluminum tone arm. The cartridge is a GE RPX-050 (60H30) variable reluctance plug-in type with GE PRJ-010 (61H28) twin sapphire needles. A 4-pole, 4-coil motor and weighted, balanced turntable eliminate hum and turntable rumble and insure constant speed. The muting switch will insure quiet operation during change cycle.

GENERAL DESCRIPTION

This model is a HI-FIDELITY two band ten tube (plus 2 rectifiers) AM and FM receiver with a three speed automatic record changer together with a pre-amp system. The I-F stages use high gain miniature type tubes. Built-in Air Wave Antennas are provided for the FM and broadcast bands. Features include compensator circuits to prevent oscillator drift, push-pull pentode power output stage, automatic volume control, a coaxial two-way 12" P.M. dynamic loud speaker and provisions for use of external AM and FM antennas if desired.

ELECTRICAL SPECIFICATIONS

Power Supply.....105-125 volts AC 60 cycles, 95 watts, 120 watts with record changer.

Frequency Ranges and Band Width.....AM—535-1620 KC—8½ KC
 FM—88-108 MC—200 KC

Intermediate Frequency.....AM—455 KC
 FM—10.7 MC

Selectivity.....AM—43 KC Broad at 1000 times signal, measured at 1000 KC
 I.F. FM—200 KC broad at 2 times down
 I.F. FM—800 KC broad at 200 times down

Tube and Dial Lamp Complement

- 1 6BA6 AM-FM R-F Amplifier
- 1 12AT7 FM Osc. & Mixer
- 1 6BA6 FM-AM 1st I-F Amplifier
- 1 6BA6 FM 2nd I-F Amplifier
- 1 6AL5 FM Detector
- 1 6AV6 Audio Amplifier, AM 2nd Detector and AVC
- 2 6V6-GT Audio Output
- 2 6X4 Rectifiers
- 1 12AX7 2nd Audio & Phase Inverter
- 1 12AX7 Pre-Amplifier
- 2 No. 47 Dial Lamps
- 3 No. 51 Indicator Lamps

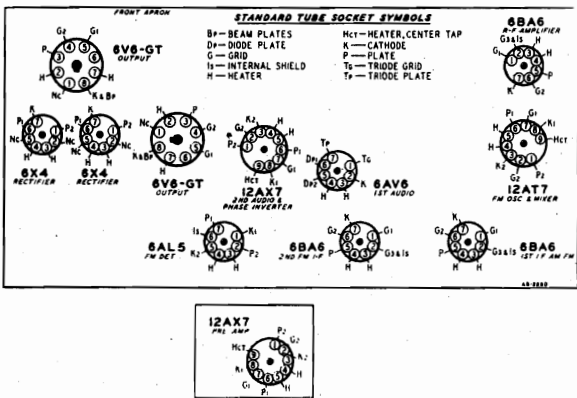
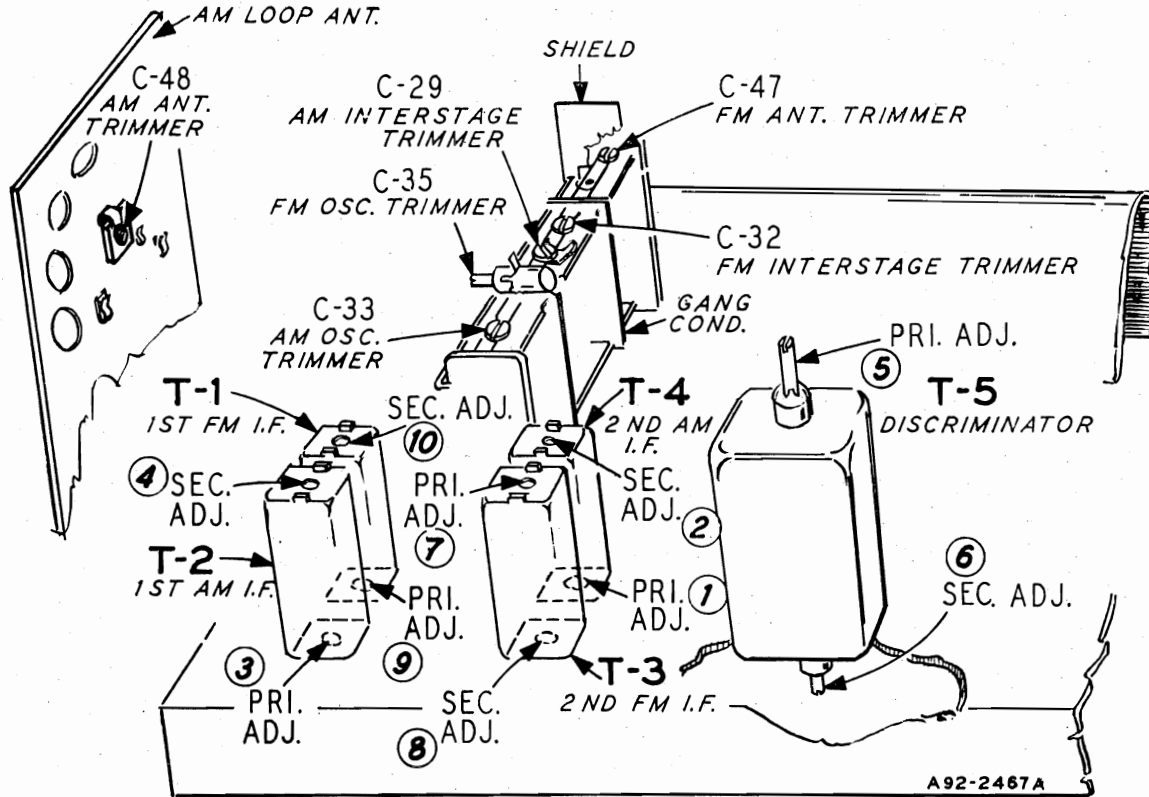

TUBE SOCKET VOLTAGES

Socket voltages are shown on the Schematic diagram at the tube socket terminals. All voltages are between the socket terminal and chassis ground. Plate, screen and cathode voltages were taken with a 1000 ohm-per-volt meter with a 300 volt scale used for plate and screen voltages. Audio grid voltages were read with a vacuum tube volt-meter. Conditions of measurement are:

- Line voltage 117 Volts AC
- Signal Input None
- A variation of $\pm 10\%$ is usually permissible.

DRIVE CORD REPLACEMENT

Use a new 10X68 drive cord assembly or a new length of cord 46 inches long for the installation, winding three turns clockwise around the drive shaft with the turns progressing away from the chassis. After completing the installation, rotate the drive shaft a few turns to take up the slack in the cord.

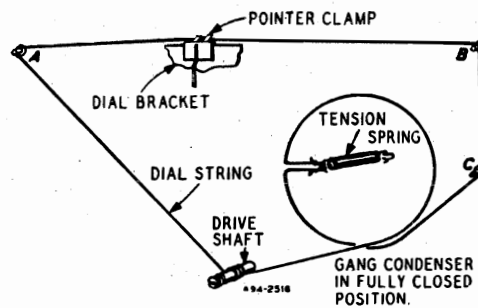

ALIGNMENT PROCEDURE AM STAGES

MODEL WG-30A8-A-496

The following is required for aligning:
An All Wave Signal Generator Which Will Provide an Accurately Calibrated Signal at the Test Frequencies as Listed.
Output Indicating Meter, Non-Metallic Screwdriver, Dummy Antennas
—.1 mf, 200 mmf.

Volume Control—Maximum all Adjustments
Connect Radio Chassis to Ground Post of Signal Generator with a Short Heavy Lead.
Allow Chassis and Signal Generator to "Heat Up" for Several Minutes.

SIGNAL GENERATOR		CONNECT GENERATOR OUTPUT TO	THROUGH DUMMY ANTENNA	BAND SWITCH SETTING	GANG CONDENSER SETTING	ADJUST	ADJUST FOR
	FREQUENCY SETTING						
I-F	455 kc	12A7 Pin 7 and Chassis	.1 mf	Broadcast	Rotor Fully Open	2nd I-F Pri. & Sec. ① & ② 1st I-F Pri. & Sec. ③ & ④	Maximum Output
Broadcast	1620 kc	External ant. term.	200 mmf	Broadcast	Rotor Fully Open	Broadcast Oscillator C-33	
	1400 kc	External ant. term.	200 mmf	Broadcast	Turn Rotor to Max. Output Set pointer to	Broadcast Interstage C-29	
	1400 kc	External ant. term.	200 mmf	Broadcast	1400 kc See Note A	Loop Antenna C-48	

Note A—If the pointer is not at 1400 KC on dial, reset pointer at the 1400 KC mark on the dial scale.

FM STAGES

The following equipment is required for aligning:
An accurately calibrated signal generator providing unmodulated signals at the test frequencies listed below.
Non-metallic screwdriver.
Dummy Antennas and I-F Loading Resistor—.01 mf, 300 ohms and 1000 ohms.

Zero center scale DC vacuum tube voltmeter having a range of approximately 3 volts.
(If a zero center scale meter is not available, a standard scale vacuum tube voltmeter may be used by reversing the meter connections for negative readings.)
Allow chassis and signal generator to warm up for several minutes

SIGNAL GENERATOR		CONNECT GENERATOR OUTPUT TO	THROUGH DUMMY ANTENNA	BAND SWITCH SETTING	GANG CONDENSER SETTING	ADJUST	ADJUST FOR
	FREQUENCY SETTING						
Discriminator	10.7 MC Note B	6BA6 2nd I-F Pin 1 and Chassis	.01 mf	FM	Rotor Fully Open	Disc. Pri. ⑤ Note A	Maximum Deflection
	10.7 MC Note B	6BA6 2nd I-F Pin 1 and Chassis	.01 mf	FM	Rotor Fully Open	Disc. Sec. ⑥ Note C	Zero Center
I-F	10.7 MC Note F	6BA6 1st I-F Pin 1 and Chassis	.01 mf	FM	Rotor Fully Open	2nd I-F Pri. Note A and D ⑦ 2nd I-F Sec. Note A and E ⑧	Maximum Deflection
Discriminator	10.7 MC Note F	6BA6 1st I-F Pin 1 and Chassis	.01 mf	FM	Rotor Fully Open	Disc. Pri. ⑤ Note A	Maximum Deflection
	10.7 MC Note F	6BA6 1st I-F Pin 1 and Chassis	.01 mf	FM	Rotor Fully Open	Disc. Sec. ⑥ Note C	Zero Center
	10.7 MC Note F	FM-RF Gang Condenser terminal	.01 mf	FM	Rotor Fully Open	1st I-F Pri. ⑨ 1st I-F Sec. ⑩ Notes A, D & E	Maximum Deflection

Recheck I-F Adjustments in order given

R-F & Osc.	108.4 Note H	Disconnect dipole and connect generator to dipole terminals with resistor in series	300 ohms	FM	Rotor Fully Open	Oscillator C-35 Note G	Maximum Deflection
	104.5	Disconnect dipole and connect generator to dipole terminals with resistor in series	300 ohms	FM	Tune Rotor for Max. AVC voltage	FM Interstage C-32	Maximum Deflection
	104.5	Disconnect dipole and connect generator to dipole terminals with resistor in series	300 ohms	FM	Tune Rotor for Max. AVC voltage	Ant. C-47	Maximum Deflection

Recheck R-F and Osc. Adjustments in order given

NOTE A—Test Equipment connections are as given in the table. The zero center scale DC vacuum tube voltmeter is to be connected between chassis ground and the AVC line at the junction of resistor R-22 and condenser C-18 for all adjustments except the discriminator secondary adjustment, for which See Note C.

NOTE B—A signal of .1 volt must be fed into the receiver for this adjustment.

NOTE C—Disconnect zero center DC vacuum tube voltmeter from AVC and connect to junction of R-18 and C-62. Adjust for zero voltage indication.

NOTE D—Before adjusting Pri. core connect 1000 ohm load resistor across the 2nd I.F. secondary terminals. Input may have to be increased to .1 volt if receiver is badly mis-aligned.

NOTE E—Disconnect 1000 ohm load resistor from secondary terminals and connect across the 2nd I.F. primary terminals. Input may have to be increased to .1 volt if receiver is badly mis-aligned.

NOTE F—Input can be reduced to 10,000 microvolts.

NOTE G—Oscillator frequency above signal frequency.

NOTE H—Remove the 1000 ohm load resistor before attempting to check the R-F and oscillator adjustments.

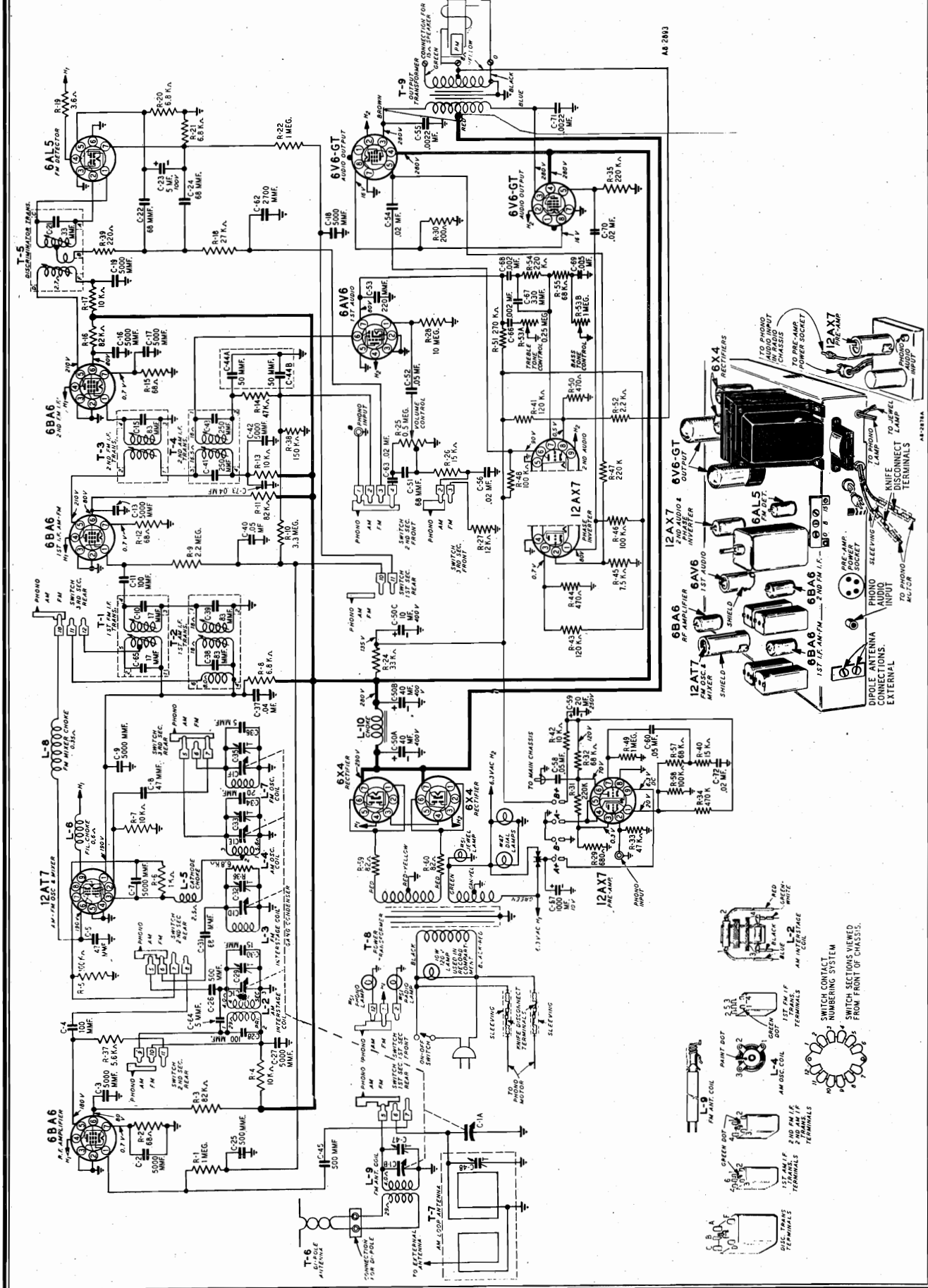

PARTS LIST

MODEL WG-30A8-A-496

Use only genuine factory tested parts (for the part numbers listed) to insure service jobs you can depend on and to obtain original set performance.

Use universal parts where no part numbers or prices are listed.

IMPORTANT — All prices in this literature are subject to change without notice and are subject to an additional charge to cover any applicable sales tax, use, occupation, or other tax affecting our purchase or sale of merchandise.

Ref. No.	Part No.	Description	List Price
CAPACITORS			
C-1A C-1B C-1C C-1D C-1E C-1F	14A207	Gang Condenser Assembly	\$7.00
C-2 C-3 C-7 C-9 C-13 C-16 C-18 C-19 C-27 C-42	47X507	5000 mmf Ceramic	.30
C-4	47X497	100 mmf Ceramic	.25
C-5	47X499	47 mmf Ceramic	.30
C-8	47X498	47 mmf Ceramic	.25
C-10 C-65	Part of T-1		
C-11 C-28	47X550	100 mmf Ceramic	.25
C-15	Part of T-3		
C-21	Part of T-5		
C-22 C-24 C-31 C-51	47X501	68 mmf Ceramic	.25
C-23	45X361	5 mf 100 V Dry Electrolytic	1.00
C-25 C-26 C-45	47X496	500 mmf Ceramic	.25
C-29 C-32 C-33 C-47	Part of Gang Condenser		
C-30	47X552	15 mmf Ceramic	.25
C-34	47X516	20 mmf Ceramic	.25
C-35	26A489	1-8 mmf Trimmer	.50
C-36 C-64	47X549	5 mmf Ceramic	.35
C-37 C-73	RCP10W6403M	.04 mf 600 V Tubular	.30
C-38 C-39	Part of T-2		
C-40 C-52 C-60	RCP10W2503M	.05 mf 200 V Tubular	.20
C-41 C-43	Part of T-4		
C-44A C-44B	47X112	50-50 mmf Dual Mica	.20
C-48	Part of T-7		
C-50A C-50B C-50C	45X403	40 mf 400 V Dry Electrolytic	4.75

Ref. No.	Part No.	Description	List Price
Capacitors—Cont.			
C-53	47X468	220 mmf Ceramic	.30
C-54 C-70	RCP10W6203M	.02 mf 600 V Tubular	.25
C-55 C-71	RCP10M10222M	.0022 mf 1000 V Tubular	.30
C-56 C-63 C-72	RCP10W2203M	.02 mf 200 V Tubular	.20
C-57	45X404	1000 mf 10 V Dry Electrolytic	2.35
C-58	RCP10W4503M	.05 mf 400 V Tubular	.30
C-59	45X405	20 mf 250 V Dry Electrolytic	1.75
C-62	47X575	2700 mmf Ceramic	.25
C-66 C-68	RCP10W6202M	.002 mf 600 V Tubular	.20
C-67	47X624	330 mmf Ceramic	.20
C-69	RCP10W2502M	.005 mf 200 V Tubular	.20
RESISTORS			
		Ohms	Watts
R-1 R-22 R-49	B85105	1.0 meg.	0.5 Carbon .10
R-2 R-12 R-15	B84680	68	0.5 Carbon .15
R-3 R-11 R-16	C84823	82 K	1.0 Carbon .20
R-4 R-42	B84103	10 K	0.5 Carbon .15
R-5	B85104	100 K	0.5 Carbon .10
R-6	B84102	1 K	0.5 Carbon .15
R-7 R-13 R-17	C84103	10 K	1.0 Carbon .20
R-8	B84682	6.8 K	0.5 Carbon .15
R-9	B85225	2.2 meg.	0.5 Carbon .10
R-10	B83335	3.3 meg.	0.5 Carbon .20
R-14	B85473	47 K	0.5 Carbon .10
R-18	B84273	27 K	0.5 Carbon .15
R-19	43X233	3.6	0.5 Wirewound .25
R-20 R-21	B83682	6.8 K	0.5 Carbon .20
R-24	C84333	33 K	1.0 Carbon .20
R-25	36X390	0.5 meg.	Volume Control 1.30
R-26	B85153	15 K	0.5 Carbon .10
R-27	B84123	12 K	0.5 Carbon .15
R-28	B85106	10.0 meg.	0.5 Carbon .10
R-29	B84681	680	0.5 Carbon .15
R-30	43X283	200	4.0 Wirewound .40

PARTS LIST (continued)

Ref. No.	Part No.	Description	List Price
RESISTORS—Cont.			
		Ohms Watts	
R-31 } R-35 } R-47 } R-54 }	B84224	220 K 0.5 Carbon	.15
R-32 } R-55 } R-57 }	B84683	68 K 0.5 Carbon	.15
R-33	B84473	47 K 0.5 Carbon	.15
R-34	B85474	470 K 0.5 Carbon	.10
R-36	D84682	6.8 K 2.0 Carbon	.30
R-37	B84562	5.6 K 0.5 Carbon	.15
R-38	B84154	150 K 0.5 Carbon	.15
R-39	B84221	220 0.5 Carbon	.15
R-40	B84153	15 K 0.5 Carbon	.15
R-41 } R-43 }	B84124	120 K 0.5 Carbon	.15
R-44 } R-50 }	B84471	470 0.5 Carbon	.15
R-45	B83752	7.5 K 0.5 Carbon	.20
R-46 } R-48 } R-58 }	B84104	100 K 0.5 Carbon	.15
R-51	B84274	270 K 0.5 Carbon	.15
R-52	B84222	2.2 K 0.5 Carbon	.15
R-53A } R-53B }	78X16	0.25 meg. Treble 1.0 meg. Bass Dual Tone Control	1.90
R-59 } R-60 }	C84820	82 1.0 Carbon	.20
TRANSFORMERS AND COILS			
L-2	9A2025	Interstage Coil (AM)	2.20
L-3	9A2024	Interstage Coil (FM)	.10
L-4	9A2022	Oscillator Coil (AM)	.15
L-5	35A5	Osc. Cathode Choke	.25
L-6	9A1881	Filament Choke	.80
L-7	9A2023	Oscillator Coil (FM)	.15
L-8	35A7	Mixer Plate Choke	.30
L-9	9A2027	Antenna Coil (FM)	1.05
L-10	52X93	Filter Choke	2.25
T-1	9A2043	1st I-F Trans. (FM)	2.15
T-2	9A2029	1st I-F Trans. (AM)	2.00
T-3	9A2030	2nd I-F Trans. (FM)	1.85
T-4	9A2042	2nd I-F Trans. (AM)	1.45
T-5	9A2064	Discriminator Coil	2.95
T-6	9A2004	Di-Pole Antenna	.95
T-7	9A2312	"B" Range Loop Antenna	2.50
T-8	53X335	Power Transformer	10.80
T-9	51X163	Output Transformer	5.50

Ref. No.	Part No.	Description	List Price
DIAL AND DRIVE ASSEMBLY			
	58X775	Dial Glass	1.40
	58X777	Glass Control Panel	4.90
	25X1650	Dial Bracket	1.40
	41X88	Dial Light Reflector	.15
	15X280	Pointer	.25
	10X68	Drive Cord Assembly	.20
	28X113	Drive Cord Tension Spring	.05
	7A199	Pilot Light Socket Assembly	.45
	7A103	No. 47 Pilot Light Bulb	.25
	19X192	"C" Washer (Mtg. Drive Shaft)	.05
	26X531	Drive Shaft	.90
	6X67	Rubber Grommet	.05
MISCELLANEOUS			
	12A514	12" PM Speaker	56.00
	3A462	Tube Socket (Miniature)	.30
	3A436	Tube Socket (12A7) (Miniature)	.80
	3A426	Tube Socket (Miniature)	.20
	3A430	Pre-Amp Socket	.15
	3A458	Tube Socket (Miniature)	.20
	3A460	Tube Socket	1.05
	3A474	Tube Socket	.15
	66X10	Selenium Rectifier	2.30
	3A305	Phono Socket (Single Pin Tip)	.10
	4A405	Antenna Terminal Strip	.10
	2A433	Band Switch	4.20
	7A252	Pilot Light Socket Assembly (Phono Ind.)	.20
	7A253	Pilot Light Socket Assembly (Radio Ind.)	.25
	7A233	Pilot Light Assembly } Cabinet	.65
	7A230	Jewel (Red) } Base	.25
	7A32	No. 51 Pilot Light Bulb (7A253—7A252—7A233)	15
	13X839-2	Line Cord & Plug Assembly	.65
	32X403	Tube Shield	.10
	32X404	Tube Shield	.25
	10A825-1	Knob (Volume Control)	1.60
	10A825-2	Knob (Tuning)	1.60
	10A825-3	Knob (Band Indicator)	1.60
	10A823-2	Knob (Tone) Outer	.50
	10A824	Knob (Tone) Inner	.50
	28X568	Spring (10A824 Knob)	.05
	7A243	Phono Light Socket Assembly (Phono Comp.)	.40
	7A244	Phono Light Bulb 10 W.	.50
TYPE V-28A193 RECORD CHANGER PARTS			
	V-6208	Motor Assembly 60 cycles 105-125 Volts A. C.
	V-6497-BG	Tone Arm (Shell only)
	V-6320-BG	Cartridge Head
	GE-RPX-050	Variable Reluctance Cartridge complete with dual stylus assembly	15.60
	GE-RPJ-010	Dual Stylus Assembly	5.50

Instructions for Using Your RADIO-ALARM CLOCK Combination Receiver

Equipped with Appliance Receptacle

This skillfully designed and carefully constructed Wakemaster will give you long and enjoyable service. This Receiver can perform the following services for the user:

1. Provide accurate sweep second time.
2. Receive broadcast programs being transmitted and within range—at any time.
3. Turn off radio or appliance at will of user up to 60-minute interval or less.
5. Turn on radio program for awakening.
6. Turn on either or both radio program for awakening and electrical appliance connected to appliance receptacle.
7. Turn on appliance at present time with radio off.
8. Turn buzzer alarm on 10 minutes after radio starts playing.
9. Turn on buzzer alarm for awakening with radio and appliance turned off.

INSTALLATION—Check the voltage and cycles of the electric power supplied to your home. This combination will operate **ONLY** on 60 cycle alternating current (a-c), from 105 to 125 volts. **THIS SET WILL NOT OPERATE ON ANY OTHER TYPE OF CURRENT OR CYCLES.** Your electric company will help you make certain that you have the correct kind of power.

This combination includes a sensitive five multi-purpose tube super-heterodyne radio including a rectifier tube. Your radio has a self contained duro-loop antenna capable of supplying sufficient volume in areas of normal reception. If you live in an area where radio reception is poor, you can improve the performance by connecting an outside antenna to the screw marked **EXT. ANT.** which you will find on the right hand side of the rear of the cabinet.

1. TO SET THE CLOCK

Your self-starting TELECHRON movement will begin operating when the set is plugged into the proper outlet and your sweep second hand begins to rotate. Set the correct time by means of the small knob at the right REAR of the cabinet. Turn **ONLY** in the direction shown on the back cover.

2. TO TURN ON RADIO MANUALLY

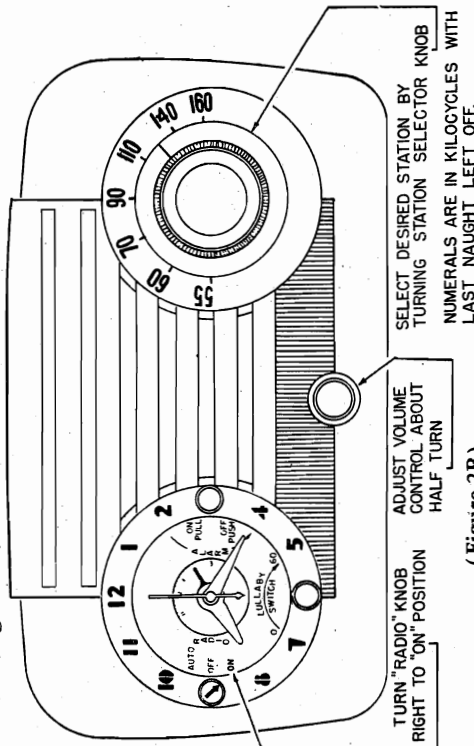
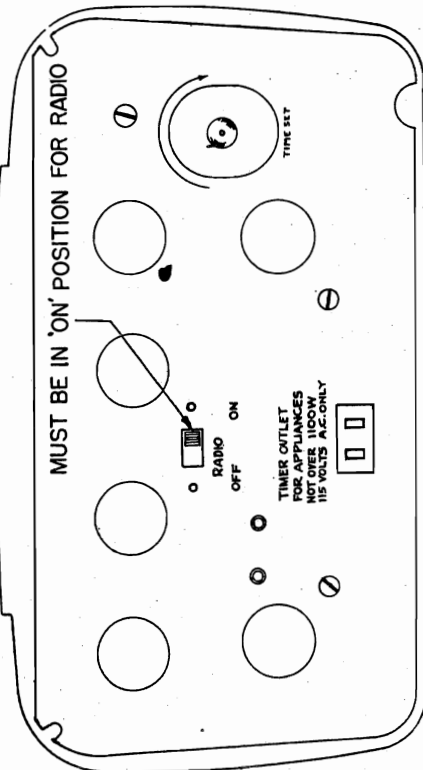

The appliance timer outlet receptacle, as shown in figure 2A, will operate such appliances as coffee maker, toaster, lamp, attic fan, etc. Their power rating must not exceed 1100 watts. The receptacle is arranged to deliver power controlled by the alarm and sleep controls of the clock movement. Thus, an appliance can be operated in a similar manner with controls set as described in Illustrations 2, 3, 4, 6, 7, and paragraphs 6, 9, and 10.

REAR RADIO ON-OFF SWITCH

The radio and appliances can be operated together. If it is desired to operate appliances with the radio turned off this is accomplished by moving this switch to the "OFF" position. **KEEP IN MIND THAT THE RADIO STAYS OFF UNLESS THIS RADIO SWITCH IS AGAIN MOVED TO THE "ON" POSITION.**

MODEL D-2015

3.

TO TURN OFF RADIO MANUALLY

Turn Lullaby Knob counter-clockwise (to left) to "O" position.

4.

TO AWAKE TO MUSIC

Select station and adjust volume to level sufficient to awaken (as indicated in Illustration 2B)

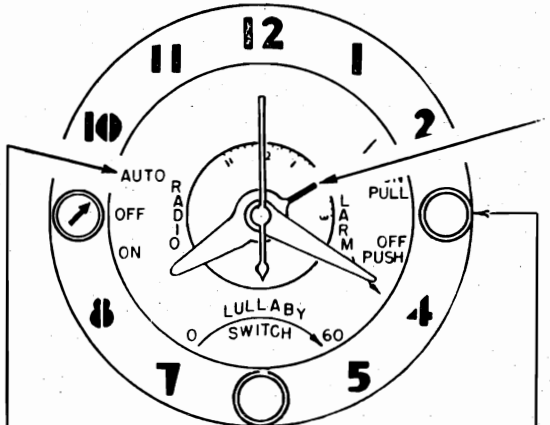

TURN "RADIO" KNOB LEFT TO "AUTO" POSITION

PULL OUT "ALARM" KNOB AND TURN IN COUNTER CLOCKWISE (ARROW) DIRECTION UNTIL POINTER IS OVER HOUR FIGURE AND MINUTE MARKS DESIRED FOR AWAKENING

THIS TIME SETTING MAY BE 11 HOURS IN ADVANCE OR LESS. AFTER HAVING SET AWAKENING HOUR PUSH IN "ALARM" KNOB.

6.

TO AWAKE TO MUSIC AND BUZZER ALARM

Select station and adjust volume to level sufficient to awaken you (as indicated in Illustration 2B)

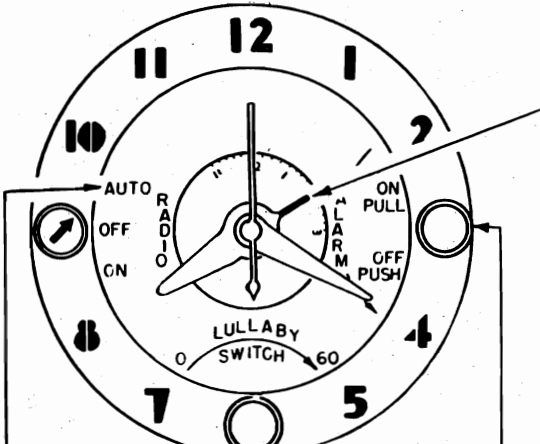

TURN "RADIO" KNOB LEFT TO "AUTO" POSITION

PULL OUT "ALARM" KNOB AND TURN IN COUNTER CLOCKWISE (ARROW) DIRECTION UNTIL POINTER IS OVER HOUR FIGURE AND MINUTE MARKS DESIRED FOR AWAKENING.

THIS TIME SETTING MAY BE 11 HOURS IN ADVANCE OR LESS.

Buzzer sounds as a reminder approximately 10 minutes after radio comes on. To shut off buzzer push in "Alarm" Knob.

5.

TO AWAKE TO BUZZER ALARM

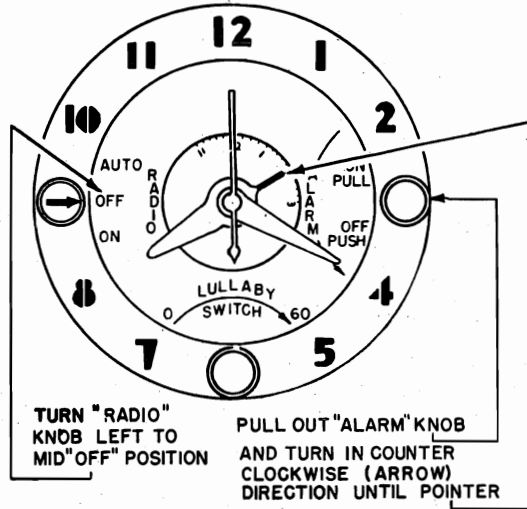

TURN "RADIO" KNOB LEFT TO MID "OFF" POSITION

PULL OUT "ALARM" KNOB AND TURN IN COUNTER CLOCKWISE (ARROW) DIRECTION UNTIL POINTER

IS SET TEN MINUTES AHEAD OF HOUR FIGURE AND MINUTE MARKS DESIRED FOR AWAKENING

THIS TIME SETTING MAY BE 11 HOURS IN ADVANCE OR LESS.

FOR EXAMPLE -- SHOULD YOU DESIRE TO AWAKEN AT 7, SET ALARM POINTER TO 6:50

TO SHUT OFF BUZZER PUSH IN "ALARM" KNOB

7.

TO TURN RADIO OFF AUTOMATICALLY WHEN RETIRING

This receiver can be adjusted to play for a period of 60 or fewer minutes before retirement if desired by the listener.

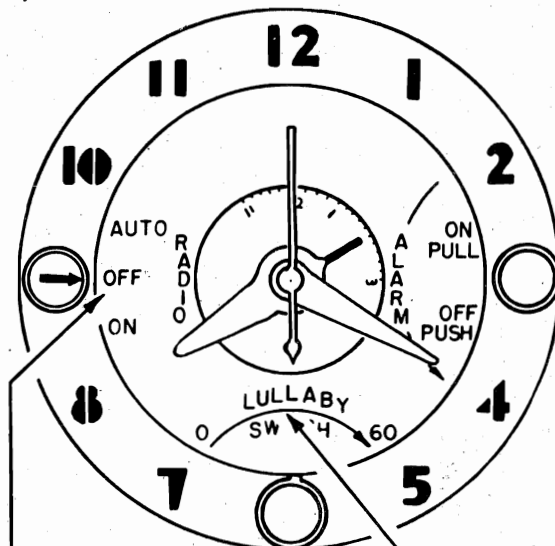

TURN "RADIO" KNOB TO MID "OFF" POSITION

TURN LULLABY KNOB CLOCKWISE (TO RIGHT) FOR PLAYING TIME DESIRED. ESTIMATE TIME BETWEEN 0 AND 60 MARKS ALONG ARROW

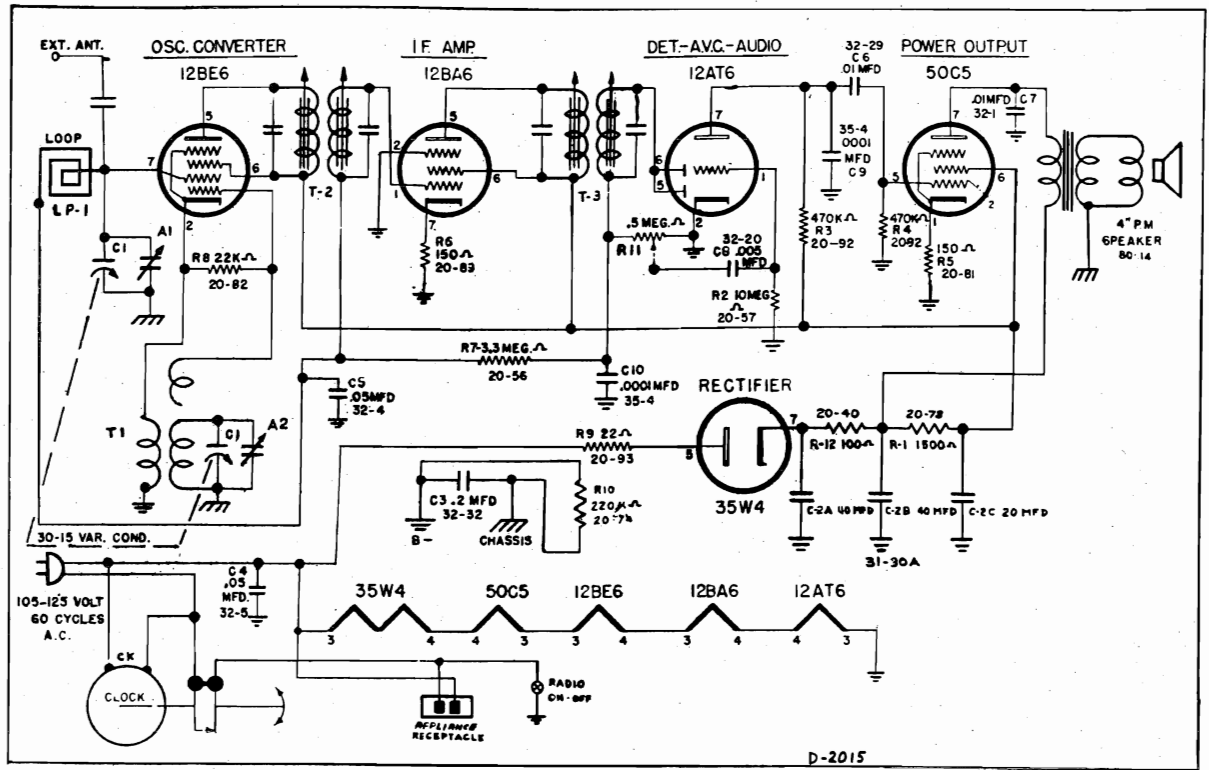

D-2015

ALIGNMENT PROCEDURE

- Output meter across voice coil (3.2 ohm)
- Volume control at maximum for all adjustments.
- Align for maximum output. Reduce input as needed to keep output near 1.28 volts (0.5 watt).

SIGNAL GENERATOR				TUNER SETTING	ADJUST TRIMMERS TO MAXIMUM OUTPUT (in order shown)
Frequency	Coupling Capacitor	Connections to Receiver	Ground Connection		
455 kc	0.1 mfd.	12BE6 grid	B—	Rotor full open (Plates out of mesh)	Input and output slugs of IF cans
1650 kc	0.1 mfd.	12BE6 grid	B—	Rotor full open (Plates out of mesh)	Oscillator trimmer A2
1500 kc		Radiating Loop		1500 kc	Antenna trimmer A1

MODEL D-2015

PARTS LIST

When ordering parts, specify part number and model number.

Ref. No.	Part No.	DESCRIPTION	List Price*
CAPACITATORS			
C1	30-15	Variable Condenser, 2 gang	\$2.16
C2	31-30A	40 mfd.—40 mfd.—20 mfd., 150 volt triple electrolytic condenser	1.75
C3	32-32	.2 mfd., 200 volt, paper	.20
C4	32-5	.05 mfd., 400 volt, paper	.20
C5	32-4	.05 mfd., 200 volt, paper	.18
C6	32-1	.01 mfd., 400 volt, paper	.20
C7	32-1	.01 mfd., 400 volt, paper	.20
C8	32-20	.005 mfd., 600 volt, paper	.20
C9	35-4	.0001 mfd., 500 volt, mica	.16
C10	35-4	.0001 mfd., 500 volt, mica	.16
RESISTORS			
R1	20-73	1500 ohm, 1 watt 20%	.10
R2	20-57	10 megohm, 1/4 watt 20%	.06
R3	20-92	470,000 ohm, 1/4 watt 20%	.06
R4	20-92	470,000 ohm, 1/4 watt 20%	.06
R5	20-81	150 ohm, 1/2 watt 20%	.06
R6	20-89	150 ohm, 1/4 watt 20%	.06
R7	20-56	3.3 megohm, 1/4 watt 20%	.06
R8	20-82	22,000 ohm, 1/4 watt 20%	.06
R9	20-93	22 ohm, 1/2 watt 20%	.06
R10	20-74	220,000 ohm, 1/4 watt 20%	.06
R11	50-15B	1/2 meg. volume control with switch	.86
R12	20-40	100 ohms, 1/2 watt 20%	.06
COILS AND TRANSFORMERS			
O-1	60-9	Oscillator coil	.70
T-2	61-11	Input IF transformer	1.36
T-3	61-11	Output IF transformer	1.36
LP-1	A125-36	Loop antenna	1.36
MISCELLANEOUS			
80-14	80-14	4 inch P.M. speaker with output transformer	4.34
122-19	122-19	Selector knob	.26
122-15	122-15	Volume knob	.10
120-33	120-33	Cabinet—walnut	3.34
CK	140-9	Clock	10.96

* Prices subject to change.

8.—To Turn Radio Off Automatically When Retiring and Awaken to Music

Set "Radio" Control as in Illustration 4.
Set "Lullaby" Knob as in Illustration 7.

9.—To Turn Radio Off Automatically When Retiring and Awaken to Buzzer Alarm

Set Controls as in Illustration 5.
Set "Lullaby" Knob as in Illustration 7.

10.—To Turn Radio Off Automatically When Retiring, Awaken to Music and Buzzer Alarm

Set "Radio" Control as in Illustration 6.
Set "Lullaby" Knob as in Illustration 7.

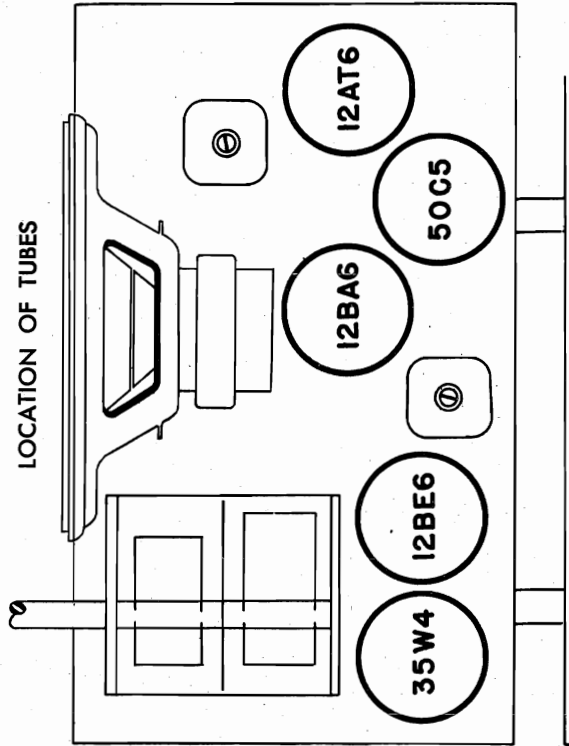

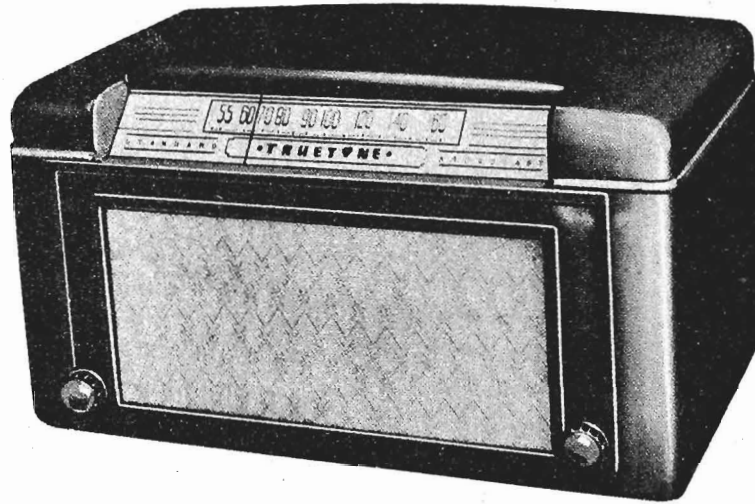

SPECIFICATIONS

4 Tube Superheterodyne
 Tuning Frequency Range 540 to 1620 kc.
 Intermediate Frequency 455 kc.

Power Output 0.25 watt maximum, 150 milliwatts (10% distortion)
 Speaker 5-inch PM Dynamic
 Speaker Voice Coil Impedance 3.2 ohms

ALIGNMENT PROCEDURE

IMPORTANT - Check to see that dial pointer indexes on dial scale. See illustration.

Volume control - Maximum for all adjustments.

Connect dummy antenna in series with high side of signal generator.

Connect generator ground to chassis.

Connect output meter across voice coil of speaker.

Use lowest output setting of signal generator capable of producing an audio output of approx. 50 milliwatts.

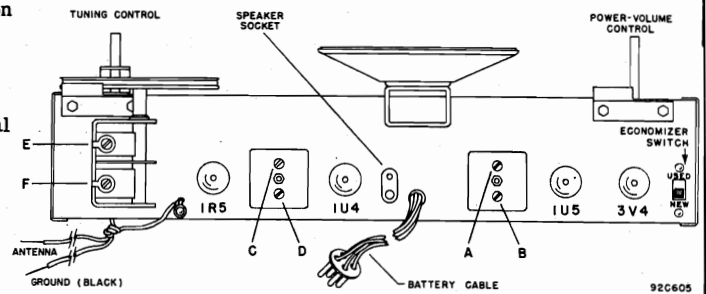

Band	Signal Generator Frequency	Dummy Antenna	Connection To Radio	Receiver Dial Setting	Trimmer Adjustment (In Order Shown)	Trimmer Function	Type of Adjustment
I.F.	455 KC.	.1 MFD.	Stator of rear section of tuning gang.	1000 KC.	A,B - 2nd. I.F.	Output I.F.	Adjust for maximum output
	455 KC.	.1 MFD.	Stator of rear section of tuning gang.	1000 KC.	C,D - 1st. I.F.	Input I.F.	Adjust for maximum output
BROADCAST	1500 KC.	.0002 MFD.	Antenna lead (Green)	1500 KC.	E F	Oscillator Mixer	Adjust for maximum output

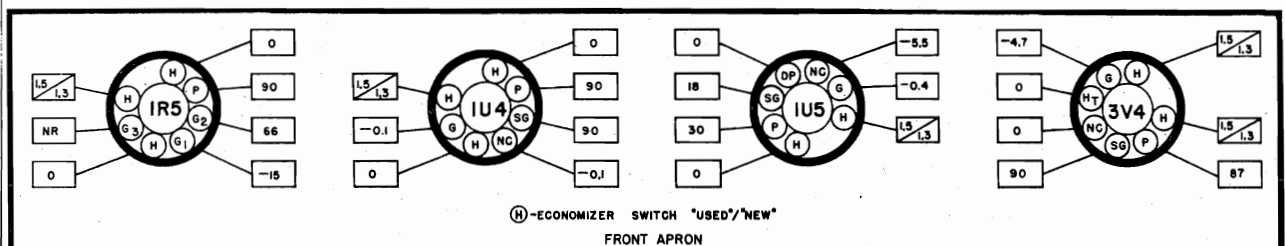

NOTES- VOLTAGE READINGS TAKEN WITH AN ELECTRONIC VOLTMETER.
 "NC"—NO CONNECTION (TERMINAL USED AS A TIE LUG).
 "NR"—NOT READABLE.

4812

Serial No. AB200501 UP

MODEL D2963

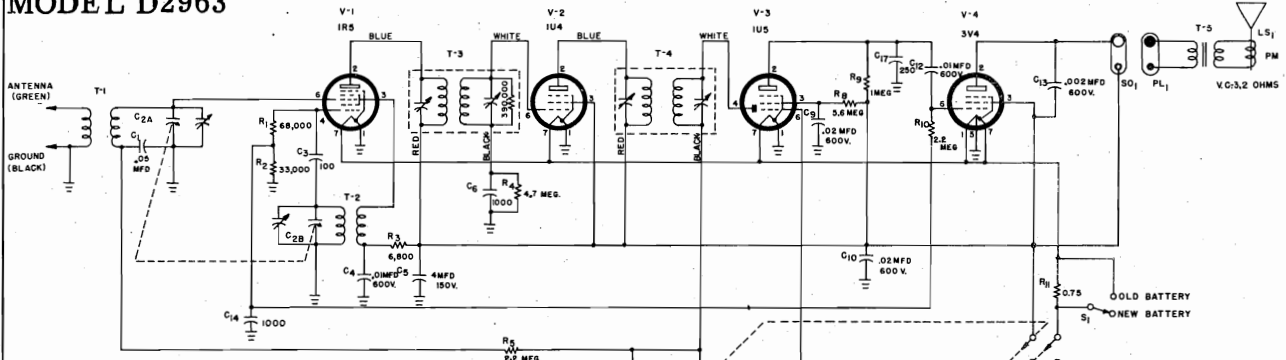

POINTER SETTINGS AND DIAL CORD REPLACEMENT

Turn the large drive pulley to close the gang. Use a 60-inch length of 30 lb. test dial cord and follow the stringing procedure outlined. Note that the cord is wound twice around the drive shaft for proper traction. With the tuning condenser at maximum capacity, attach the pointer and index it with the extreme left hand dial marker.

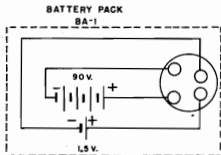

BATTERY SUPPLY

This receiver is designed to operate on a single unit Wizard B6430, Wizard B6432, Ray-O-Vac No. AB-82, Burgess 17G-D60, Eveready 748, Bond 0528 or General 60DL-ILL battery.

C-8	46AZ602J	.006 mfd. 600 V., tubular	.15
C-9,10	46AY203	.02 mfd. 600 V., tubular	.20
C-13	46AZ202J	.002 mfd. 600 V., tubular	.15

TRANSFORMERS

T-1	51B1084	Transformer, mixer	.85
T-2	51B1085	Transformer, oscillator	1.03
T-3	50B412	Transformer, 1st IF	1.60
T-4	50B413	Transformer, 2nd IF	1.56
T-5		Transformer, output (Part of speaker ass'y.)	

RESISTORS

R-1	RC20AE683K	68,000 ohms 1/2 watt, carbon	.16
R-2	RC20AE333K	33,000 ohms 1/2 watt, carbon	.16
R-3	RC20AE682M	6800 ohms 1/2 watt, carbon	.16
R-4,7	RC20AE475K	4.7 megohms 1/2 watt, carbon	.16
R-5,10	RC20AE225K	2.2 megohms 1/2 watt, carbon	.16
R-6	25B806	1 megohm, volume control	.85
R-8	RC10AE565M	5.6 megohm 1/4 watt, carbon	.16
R-9	RC20AE105K	1 megohm 1/2 watt, carbon	.16
R-11	23A062	.75 ohms 1/2 watt carbon	.16

DIAL AND DRIVE ASSEMBLY

		List Price	
82B155	Pointer	.16	
74A256	Shaft, tuning	.12	
4A192	"C" washer	.05	
4A195	Washer, spring	.05	
75A012	Tension spring, drive cord	.05	
38A001	Cord, dial drive	.05/yd	
22B225	Dial glass (clear)	.96	
67C883	Dial backing	1.08	
76A412	Clip, dial glass	.05	

Prices subject to change without notice.

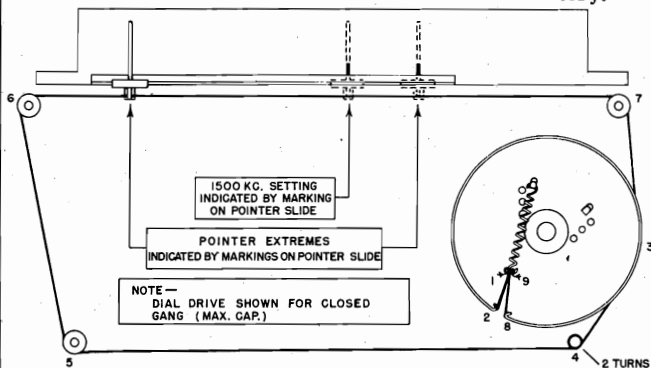

ECONOMIZER SWITCH

The battery Economizer Switch is located on the top of the chassis, left side. (See illustration) ALWAYS HAVE THIS ECONOMIZER SWITCH IN THE "NEW" BATTERY POSITION WHEN THE RADIO IS NEW OR AFTER A NEW BATTERY HAS BEEN INSTALLED. When the volume of stations decreases noticeably (After 200 or 300 hours of actual use), this switch should be pushed to the "USED" battery position.

MISCELLANEOUS

LS-1	85C085	Speaker ass'y. (Includes PL-1, T-5)	List Price \$ 5.40
SO-1	6A275-0	Socket, speaker	.10
	6A314	Socket, miniature (tube)	.14
PL-2	87B1555-1	Battery cable ass'y.	.94
	66D500	Cabinet, plastic	10.60
	14B175	Grill cloth	.65
CAPACITORS			
C-1	46AU503J	.05 mfd. 200 V., tubular	.19
C-2	48B208	Tuning condenser, 2 section	2.30
C-3	CM20A101M	100 mmf. 500 V., mica	.16
C-4,12	46AY103J	.01 mfd. 600 V., tubular	.15
C-5	45A143	4 mfd. 150 V., electrolytic	.75
C-6,14	47B20A102M3	1000 mmf. 350 V., ceramic	.20
C-7,11	CM20A271M	270 mmf. 500 V., mica	.18

NOTICE: There is a model number label on the chassis. This label identifies the radio. When ordering parts or writing, give ALL information appearing on this label.

GENERAL DESCRIPTION

This model is a 3-way portable radio with 4 tubes plus a selenium rectifier and uses a built-in antenna. The receiver will operate on 115 volts, 50 to 60 cycles AC, or 115 volts DC, or on the self-contained batteries. When using the radio on AC, reversing the plug may reduce hum. If the radio does not operate in one minute on direct current (DC), reverse the plug. When bat-

tery operation is desired, the line cord plug is inserted into a socket switch on the chassis (see bottom cabinet view), the insertion automatically moves the switch contacts for battery operation. When the line cord plug is out of the chassis switch, the batteries are automatically disconnected.

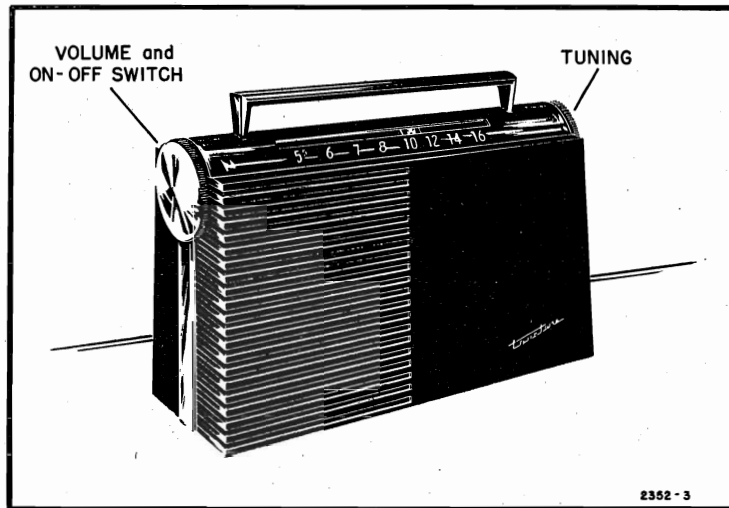

OPERATION

OFF-ON SWITCH AND VOLUME CONTROL

The knob on the left is both the on-off switch and the volume control. When the control is turned all the way counter-clockwise, the set is off. A slight clockwise rotation will click the switch and turn the set on. The knob may then be used to regulate the volume. Be sure your set is turned completely off when not in use; otherwise the tubes will wear out and/or the batteries will be discharged unnecessarily.

TUNING KNOB

The knob on the right is the tuning knob; rotation of this knob moves the indicator along the dial scale. When selecting a station turn the knob back and forth until the tone is clearest and loudest. Do not use the tuning knob to regulate volume; the volume control should be used for that purpose after the station selector has been tuned in properly.

SPECIFICATIONS

Power Supply..... 115 volts, DC or 50-60 cycles AC, 25 watts.
 A Battery—7.5 volts, 50 milli-amperes.
 B Battery—90 volts, 14 milli-amperes
Frequency Range... 540 to 1600 kc.
Intermediate Freq.... 455 kc.
Selectivity..... At 1000 kc., 60 kc. at 1000 x signal

Sensitivity..... 500 microvolts per meter
Power Output..... 150 milliwatts, undistorted
 250 milliwatts, maximum
Loud Speaker..... 5" PM, v.c. impedance 3.2 ohms
Tube Complement....
 1R5, Converter, 1U5, detector, AVC, audio amp.
 1U4, I.F. amplifier, 3V4, output amplifier,
Rectifier..... Selenium type.

514
 Serial No.B-394901 up

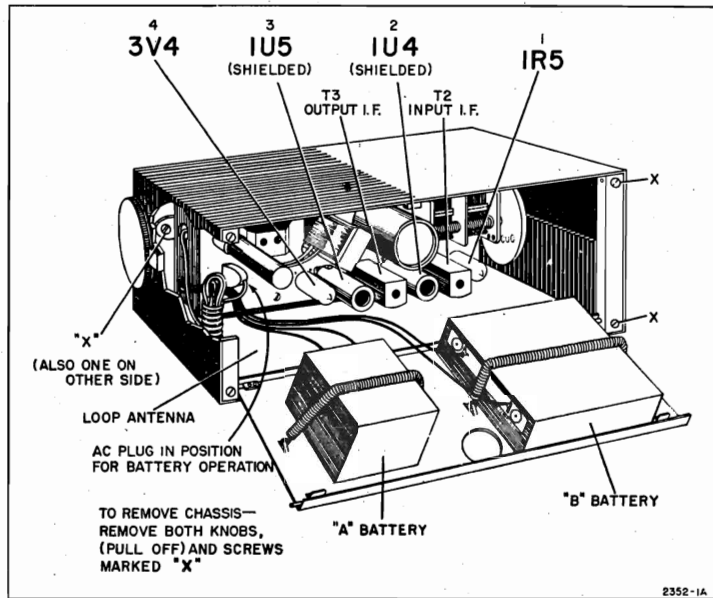

Bottom Chassis View

Manufacturer	A	B
RCA	VS-065	VS-090
General	31	132
Ray-O-Vac	P-751	4390
Eveready	717	490
Burgess	C5	N60

BATTERY REPLACEMENT

Since the receiver is small and compact, not every A or B Battery will fit in the space provided. Listed to the left are the five most common manufactured types to be used for replacement.

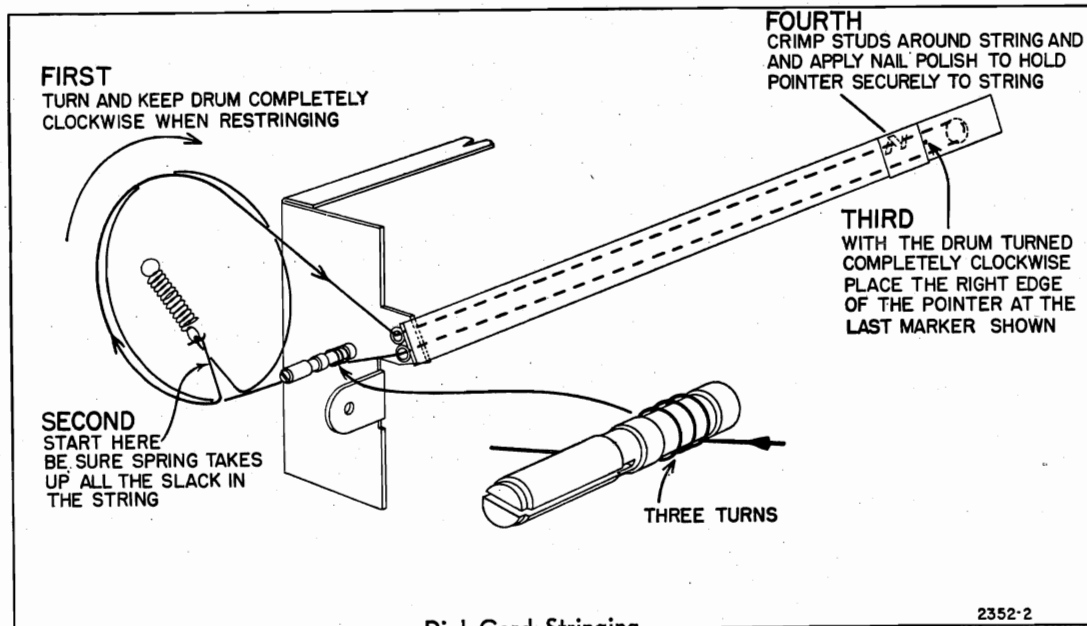

Dial Cord Stringing

2352-2

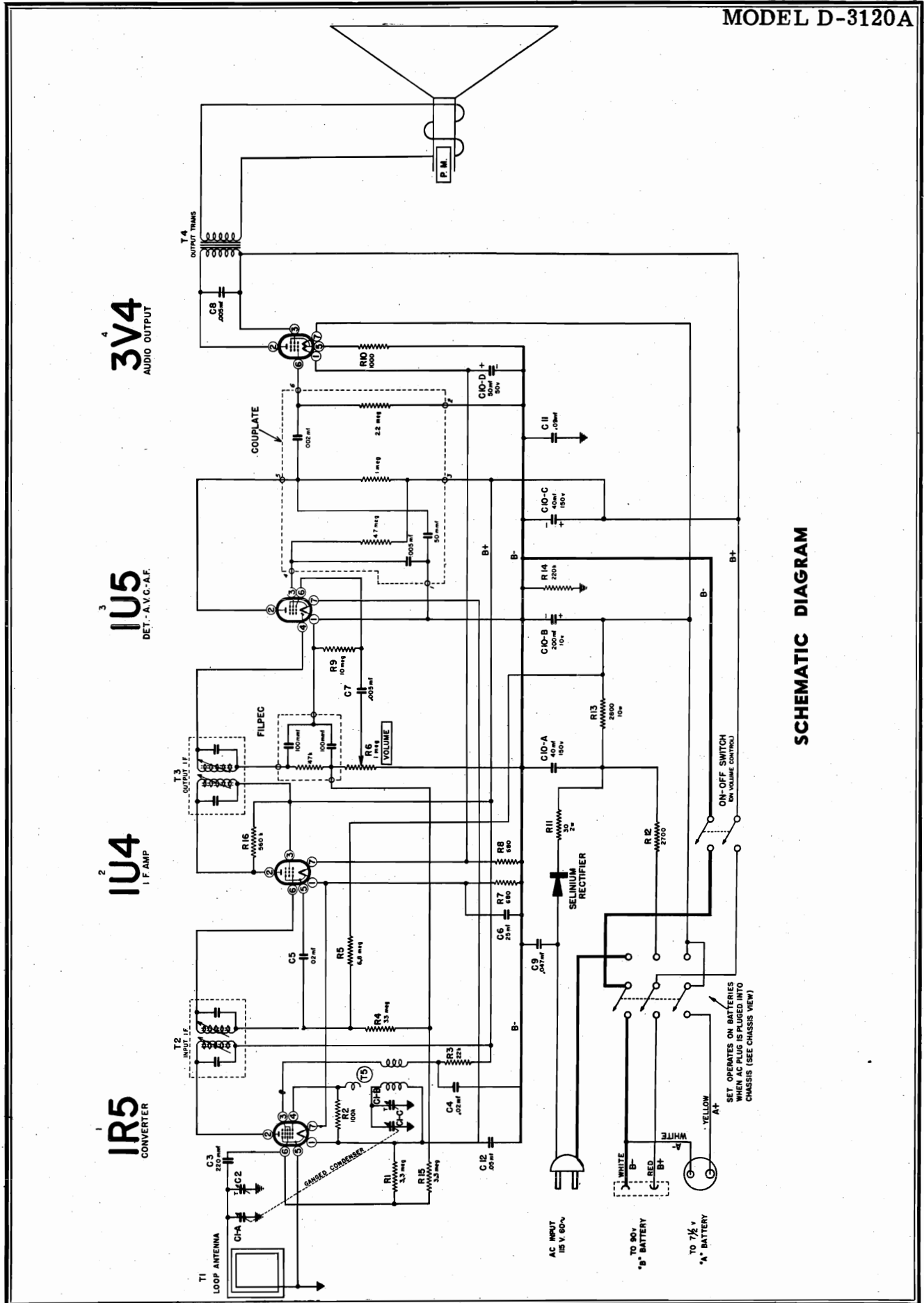

SCHMATIC DIAGRAM

MODEL D-3120A

ALIGNMENT PROCEDURE

The Alignment Procedure below includes the sensitivities at the input of various stage. All measurements are based on an output of 50 milliwatts. This may be measured by disconnecting the speaker voice coil and substituting a 3.2 ohm, 5 watt resistor across the secondary winding of the output transformer. A reading of .4 volts AC across this resistor will be equivalent to a

50 milliwatt output with speaker connected. The volume control must be set to maximum.

The signal source must be an accurately calibrated signal generator capable of supplying the frequencies designated, modulated 30% with a 400-cycle audio signal. A 400-cycle audio signal is required for the audio measurement. Variations in sensitivities of plus or minus 25% are usually permissible.

FREQUENCY	COUPLING CAPACITOR	DIAL SETTING	CONNECTION TO RADIO	GROUND CONNECTION	ADJUST	INPUT FOR 50 MILLIWATTS OUTPUT
455 kc.	.1 mfd.	1000 kc.	Pin No. 6 of 1R5	B— (shell of lytic)	I.F. slugs	100 microvolts
1620 kc.	.1 mfd.	1600 kc.	Pin No. 6 of 1R5	B— (shell of lytic)	C1-B Osc. Trim. on gang	_____
1400 kc.	Radiation Loop	1400 kc.	Radiation loop	None	C-2 Antenna Trim. on gang	250 microvolts
400 cycles	.05 mfd.	_____	Pin No. 6 of 1U5	B— (shell of lytic)	_____	.040 volts
400 cycles	.05 mfd.	_____	Pin No. 6 of 3V4	B— (shell of lytic)	_____	3 volts

PARTS LIST

When ordering parts, specify part number and complete model number

Ref. No.	Part No.	Description	Price	Ref. No.	Part No.	Description	Price
Capacitors							
CA-C	13D-19595	Gang tuning condenser	.80	18A-19586	5", PM speaker	5.70	
C1-B		Trimmer on gang	—	21J-19615	Selenium rectifier	2.25	
C2		Trimmer on gang	—	201-14083	Audio couplate	.85	
C3	8G-14459	220 mmf, ceramic	.25	201-15005	Filpec	.40	
C4, 5	8D-17268	.02 mfd x 200 volts	.25	15C-16007	7 prong, miniature socket	.15	
C6	8D-18042	.25 mfd x 100 volts	.35	2H-17008	Tube shield base	.10	
C7	8D-17785	.005 mfd x 200 volts	.25	2H-19188	Tube shield	.10	
C8	8G-13962	.005 mfd x 450 volts	.25	14M-15724	A.C. line cord	.85	
C9	8J-16081	.047 mfd x 400 volts	.30	5M-19963	Line cord lock	.10	
C10A, B, C, D	8C-16068	40-200-40-50 mfd, lytic	2.95	14A-16919	"B" Battery cable	.35	
C11	8D-11251	.09 mfd x 400 volts	.25	14A-19846	"A" battery cable	.35	
C12	8D-14460	.05 mfd x 200 volts	.35	Cabinet Parts			
Resistors				5C-19576-84	Bakelite cabinet	4.25	
R1, 4, 15	9B1-104	3.3 megohms, 1/2 watt, 10%	.25	4M-19581	Handle	2.50	
R2	9B1-86	100K ohms, 1/2 watt, 10%	.25	4B-19574	Escutcheon and dial scale	3.30	
R3	9B1-78	22K ohms, 1/2 watt, 10%	.25	2M-19647	Tie strap	.10	
R5	9B1-108	6.8 megohms, 1/2 watt, 10%	.25	2M-19585	Clip, cabinet side channel	.40	
R6	10A-19596-1 or 10A-19596	Volume control and switch, 1 megohm	1.20	2M-19609	Button cover	.85	
R7, 8	9B1-155	680 ohms, 1/2 watt, 5%	.30	49A-19612	Spring, battery	.20	
R9	9B1-37	10 megohms, 1/2 watt, 20%	.25	4B-19582	Knob	.90	
R10	9B1-159	1K ohms, 1/2 watt, 5%	.30	2M-19614	Stud	.10	
R11	9C-19770	30 ohms, 2 watts, 10%	.20	27C-6030	Rivet	.01	
R12	9B2-169	2700 ohms, 1 watt, 5%	.35	3M-19613	Shoulder stud	.05	
R13	9M-19833	2800 ohms, 10 watts, clarostat	.95	2D-19610	Bracket	.20	
Coils, Transformers and Chokes				2M-17580	I.F. clip	.05	
T1	13E-19844	Loop antenna assembly	1.30	62D-19893	Antenna clip	.15	
T2	13B-17397	Input I.F. transformer	1.45	6M-14372	Clamp, battery cable	.10	
T3	13B-17397	Output I.F. transformer	1.45	Dial Parts			
T4	12C-19591	Audio output transformer	1.85	2G-19590	Pointer	.40	
T5	13D-19595	Oscillator coil	.80	49A-11324	Tension spring	.05	
Miscellaneous				2M-19584	Pointer guide	.25	
	20A-19588	A.C. - D.C. battery switch	.90	3H-10879	Pulley	.10	
				27A-10102	Shoulder rivet	.05	
				3A-19583	Tuning shaft	.40	
				29C-10630	"C" washer	.05	

PRICES SUBJECT TO CHANGE WITHOUT NOTICE

MODELS D-2102A, B,
D-2103A, B

SERVICE DATA

Power Supply.....115 volts, DC or 50-60 cycle, AC,
24 watts.
Frequency Range.....540 to 1600 Kc.
Intermediate Freq....455 Kc.
Selectivity.....At 1000 Kc., 60 Kc., at 1000 x
signal
Sensitivity.....150 u. v. per meter
Power Output.....0.8 watts undistorted, 1.0 watt
maximum
Loud Speaker.....4" PM., v.c. impedance, 3.2-ohms
Tube Complement.....
12BE6, Converter
12BA6, IF Amplifier
12AV6, or 12AT6,
Detector, AVC, Audio
50C5, Audio output
25Z6, Rectifier

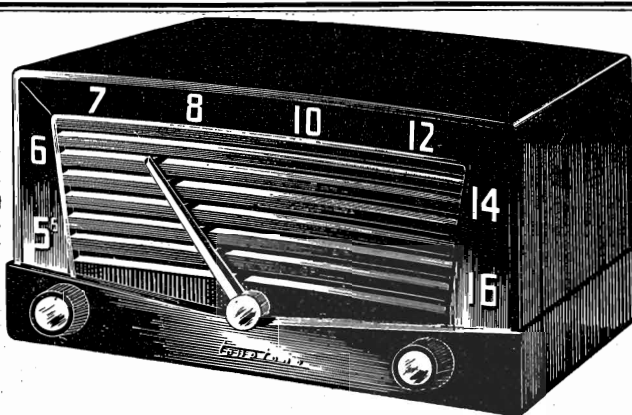

Front Cabinet View

MODEL D-2102A AND D-2103A

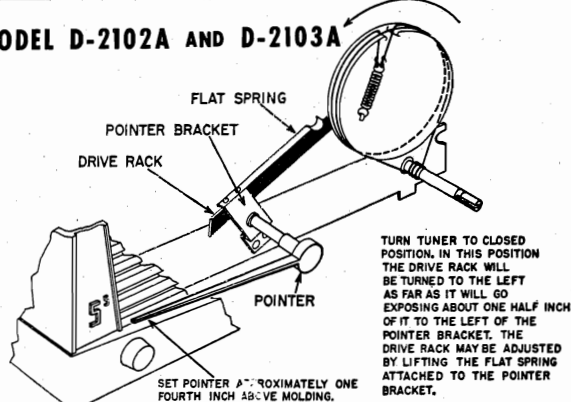

Dial Stringing Diagram

MODEL D-2102B AND D-2103B

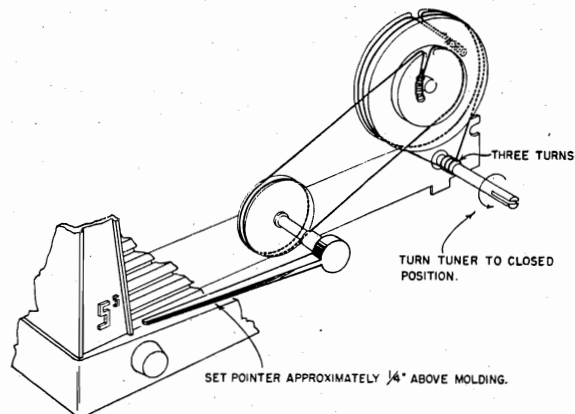

Dial Stringing Diagram

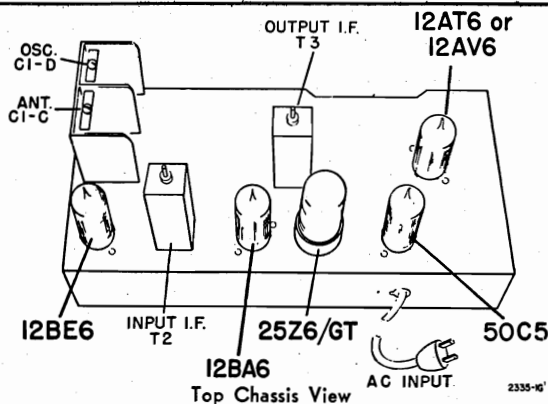

Top Chassis View

ALIGNMENT PROCEDURE

Loop must be connected and set volume to maximum.

SIGNAL GENERATOR				TUNER SETTING	ADJUST FOR MAXIMUM OUTPUT	INPUT FOR 50-MILLIWATT OUTPUT
Frequency	Coupling Capacitor	Connection to Radio	Ground Connection			
455 kc.	.1 mf	12BE6, Pin 7	HEAVY BUSS LEAD ACROSS CENTER OF CHASSIS	Capacitor fully open (plates out of mesh)	Top and bottom Cores in output and input I.F. cans	65 microvolts
1620 kc.	.1 mf	12BE6, Pin 7		Capacitor fully open (plates out of mesh)	Oscillator trimmer C1-D on gang	70 microvolts
535 kc.	.1 mf.	12BE6, Pin 7		Capacitor fully closed	Check for adequate range	70 microvolts
1400 kc.	—	Lay generator lead near back of cabinet		Tune in 1400 kc. signal	Antenna trimmer C-1C on gang	200 to 400 microvolts
400 cycles	.1 mf	12AT6, Pin 1		—	—	.06 volts

Serial No. 367000 up 514

MODELS D-2102A,
B, D-2103A, B

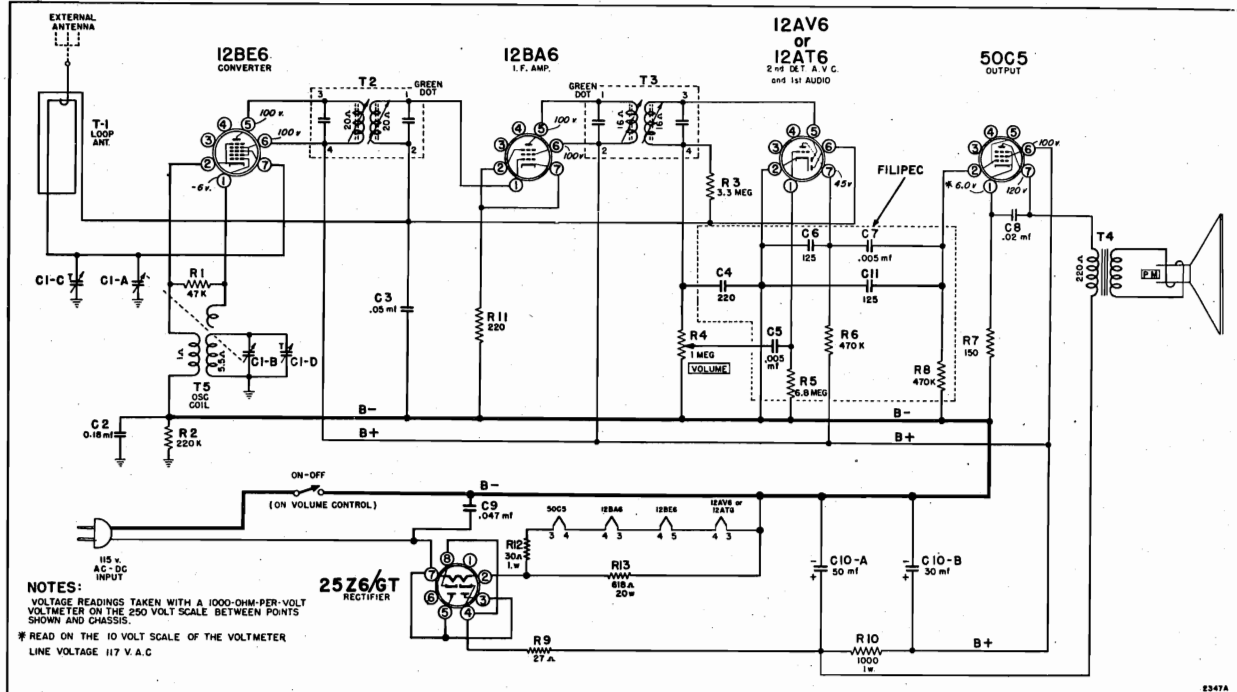

NOTE: Capacitor C2 should be .09 mmf.

SCHEMATIC DIAGRAM

Please specify part number and chassis model number when ordering replacements.

Ref. No.	Part No.	Description	Price	Part No.	Description	Price
Capacitors						
C1A-B	8A-19553	2-gang condenser	2.85	29E-17592	Spring washer	.05
C1C-D	8A-20219	Trimmers on gang		43D-17609	Tinnerman clip	.05
C2	8D-11251	.09 mfd x 400 volts	.25	29C-10630	"C" washer	.05
C3	8D-10770	.05 mfd x 200 volts	.25	53A-18547	Dial string (approx 20")	.05
C4-5-6-7-11- and R5-6-8	201-19303	Filipec	.90	49A-15616	Take up spring	.05
C8	8D-10774	.02 mfd x 400 volts	.25	2D-19555	Pointer bracket	.05
C9	8J-16081	.047 mfd x 400 volts	.30	2M-19545	Flat spring	.03
C10-A-B	8C-17391	Electrolytic condenser	1.25	3A-19556	Pointer shaft	.05
Resistors						
R1	9B1-82	47K ohms, 1/2 watt, 10%	.25	3J-19557	Pointer gear	.50
R2	9B1-27	220K ohms, 1/2 watt, 20%	.25	38A-19558	Drive rack	.05
R3	9B1-34	3.3 megohms, 1/2 watt, 20%	.25	2G-19559	Pointer	.40
R4	10A-19788	Volume control and switch	1.10	200-20227	Shaft and pulley assembly	.20
R5-6-8		See Filipec		49A-11324	Coil spring	.05
R7	9B1-52	150 ohms, 1/2 watt, 10%	.25	Miscellaneous		
R9	9B1-43	27 ohms, 1/2 watt, 10%	.25	5C-19530-65	Cabinet (walnut)	3.80
R10	9B2-62	1000 ohms, 1 watt, 10%	.25	5C-19530-9	Cabinet (ivory)	5.15
R11	9B1-54	220 ohms, 1/2 watt, 10%	.25	5B-18164-37	Knob (walnut)	.30
R12	9C-19769	30 ohms, 1 watt, 10%	.15	5B-18164-8	Knob (ivory)	.30
R13	9M-19602	618 ohms, 20 watts, 10%	1.10	18A-19554	Speaker, 4" PM	4.75
Transformers and Coils						
T1	13E-19560	Loop antenna assembly	1.25	43D-17609	Tinnerman clip	.05
T2-3	13B-17731	I.F. transformer	1.45	2H-17588 or 2H-19188	Tube shield	.10
T4	12C-17595	Output transformer	1.00	2M-17589 or 2M-19187	Tube shield base	.05
T5	13D-17583	Oscillator coil	.70	2M-17580	I.F. locking clip	.05
Dial Parts						
	3A-17590	Tuning shaft	.20	15C-16007	7-prong, socket	.15
	40A-17591	Bushing	.05	15B-10440	Octal socket	.15
				14M-10088-4	AC line cord and plug	1.00
				2D-15432-1	Loop mounting bracket	.35
				23A-10344	Line cord lock	.05

PRICES SUBJECT TO CHANGE WITHOUT NOTICE

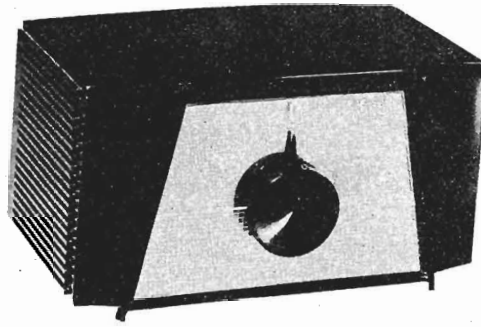
MODELS D2386,
D2387, D2388

INSTALLATION

Place the receiver upright on a table or other level surface convenient to a power outlet. Do not place it on or near a radiator or heater.

This receiver is designed to operate from a 117 Volt A C or D C source of supply. On A C, improved reception may sometimes be obtained by turning the plug halfway around and reinserting it into the power outlet. Try it both ways and leave it in the position which gives the best reception. On D C, the receiver will operate with the plug inserted in only one position.

ANTENNA

A 15 foot hank antenna is attached to the receiver which should be uncoiled and stretched out to its full length for best reception. Run the wire around the room floor and around window frames for good signal pickup.

In locations of low signal areas an Outdoor Antenna will greatly improve reception and our Western Auto Aerial Kits Numbers 3D5111 and 3D5110 will prove highly satisfactory by increasing the reception volume level.

This receiver is designed to operate without a ground connection and no attempt should be made to use one.

OPERATION

Insert the power cord plug into the power receptacle. To turn the receiver on, turn the Volume Control knob located on the right side of the receiver until a click is heard. In about 30 seconds the set will be in operating condition. Turning the Volume to the right or clockwise increases the volume.

Tune in stations by turning the large center tuning knob. The numbers the tuning knob passes over, show Kilocycles with the last two ciphers left off. For example number 9 is the location of 900 Kilocycles. As you have tuned in the station desired move the tuning knob to the position which produces the deepest rounded tones with a minimum background noise and clearest reception.

To turn the receiver off, turn the volume knob to the left or counter clockwise position until a click is heard.

ELECTRICAL SPECIFICATIONS

Power Supply.....117 Volts D.C., or 117 Volts, 50-60 Cycles A.C.
 Frequency Range..... 532.5 to 1620 kc.
 Intermediate Frequency.....455 kc..
 Tuning..... Two gang capacitor
 Speaker..... 4 inch PM, 3.2 ohm voice coil impedance
 Power Consumption.....30 Watts
 Power Output..... 1 watt undistorted, 1.5 watt maximum
 Sensitivity..... 800 Microvolts at 50 milliwatts Output
 Selectivity.....120 kc. broad at 1000 times signal at 1000 kc.

TUBE COMPLEMENT

12 BE 6Mixer and Oscillator
 12 SQ 7.....Detector, A.V.C. and 1st Audio
 50 C 5..... Audio Output
 35 W 4.....Power Rectifier

MODELS D2386,
D2387, D2388

TUBES

This receiver is shipped with the tubes in their proper sockets. If for some reason tubes have been removed, make certain they are reinserted into their proper sockets as shown below.

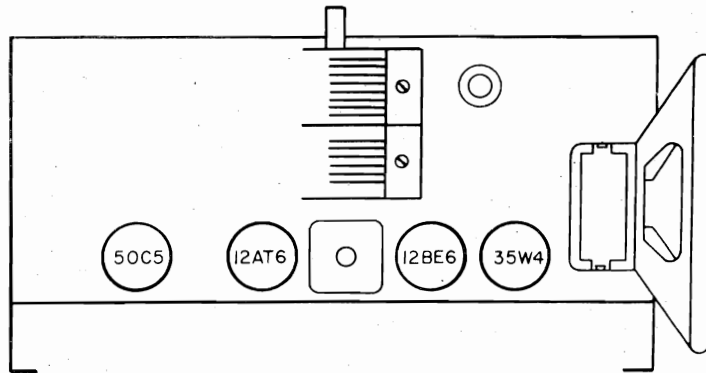

ALIGNMENT PROCEDURE

PRELIMINARY:

- Output meter connection..... Across 3.2 ohm speaker voice coil
- Output meter reading to indicate 0.05 watt across speaker voice coil..... 0.4 volt
- Generator Modulation..... 30%, 400 cycles
- Position of volume control..... maximum (fully clockwise)
- Position of pointer with Rotor full open (Plates out of mesh)..... slightly beneath the 1620 kc calibration mark on the dial (pointer horizontal to light)

	Position of Variable	SIGNAL GENERATOR				Trimmer Adjustments (In order shown)
		Frequency	Dummy Antenna	Connection to Receiver	Ground Connection	
IF	Rotor Full Open (Plates out of mesh)	455 kc.	.1 mfd	Grid of 12BE6 (Pin 7)	B-	Input and Output Trimmers on I.F. Can T3 and T4
RF	Rotor Full Open (Plates out of mesh)	1620 kc.	75 mmf	Antenna Hank	Chassis	Oscillator Trimmer T2
	1400 kc.	1400 kc.	75 mmf	Antenna Hank	Chassis	Antenna Trimmer T1
	600 kc.	600	75 mmf	Antenna Hank	Chassis	(Check Point)*

*With a generator frequency of 600 Kc, tune the set to the point where maximum output is obtained, which should be approximately 600 Kc on the dial.

Align for maximum output. Reduce input as needed to keep output near 0.4 volts.

The alignment procedure should be done in the order given for greatest accuracy.

Always keep the output from the generator at its lowest possible value to prevent the AVC of the receiver from interfering with accurate alignment.

MODELS D2386,
D2387, D2388

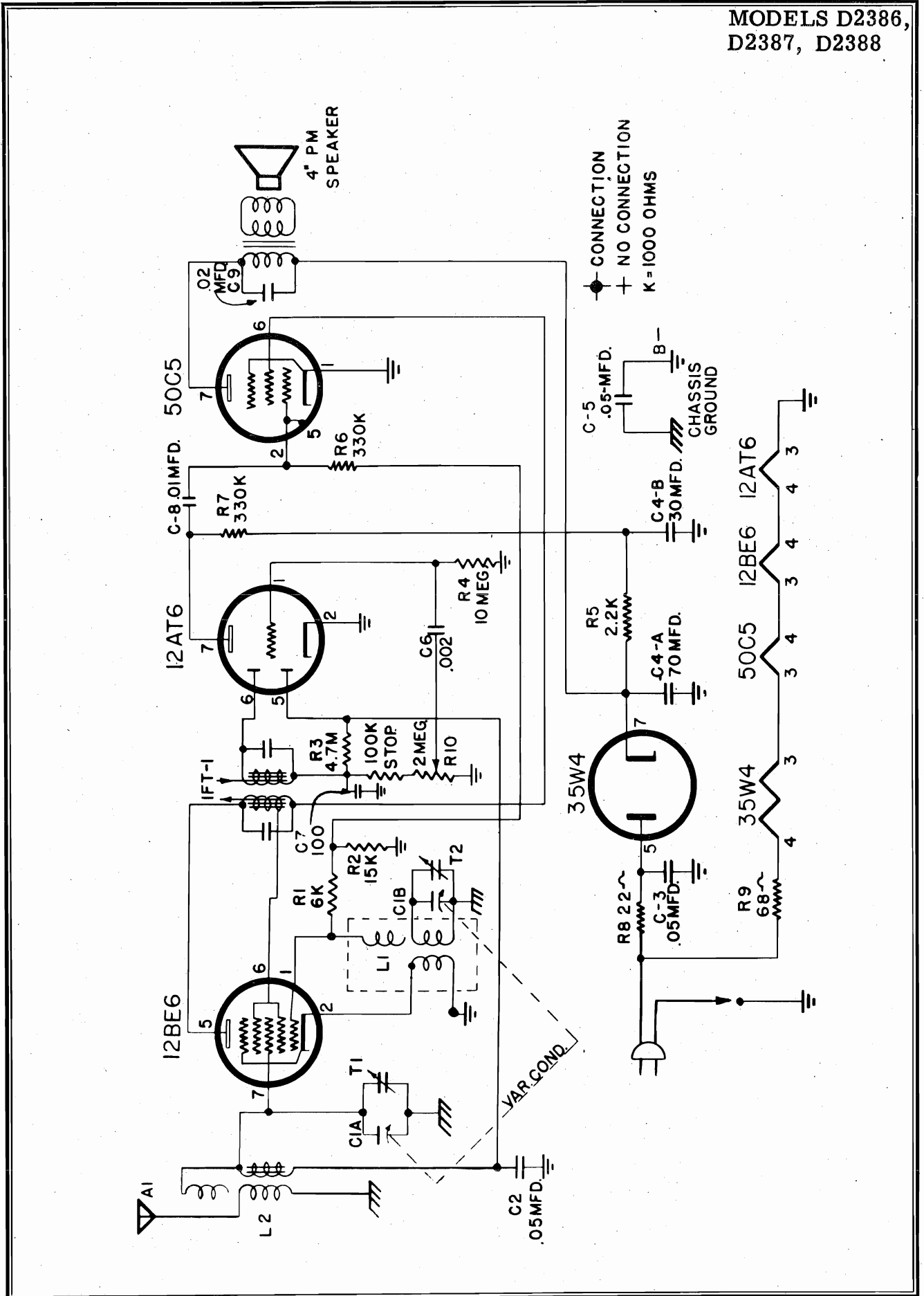

MODELS D2386,
D2387, D2388

PARTS LIST

When ordering parts, specify part number, model number and series.

Ref. No.	Part No.	Description
RESISTORS		
R1	180-126	6000 Ohms 1/2 W 20%
R2	180-115	15000 Ohms 1/2 W 20%
R3	180-122	4.7 Megohms 1/2 W 20%
R4	180-123	10 Megohms 1/2 W 20%
R5	180-124	2200 Ohms 1 W 20%
R6	180-109	330000 Ohms 1/2 W 20%
R7	180-109	330000 Ohms 1/2 W 20%
R8	180-113	22 Ohms 1/2 W 20%
R9	180-125	68 Ohms 1 W 20%
R10	120-104	2 Megohms, Volume control 100000 stop & switch

CONDENSERS

C1A-B	160-104	Variable Condenser
C2	152-104	.05 Mfd 200 Volt Paper
C3	152-105	.05 Mfd 400 Volt Paper
C4A-B	150-107	70x30 Mfd 150 Volt Electrolytic
C5	152-105	.05 Mfd 400 Volt Paper
C6	158-103	.002 Mfd 400 Volt Disc
C7	156-102	100 Mfd Ceramicon
C8	158-102	.01 Mfd 200 Volt Paper
C9	158-104	.02 Mfd 200 Volt Paper

COILS & TRANSFORMERS

L2	132-104	Antenna Coil
L1	136-106	Oscillator Coil
T1	130-103	I F Transformer

CABINET and ACCESSORIES

210-103 WH	Cabinet, White D 2387 (In carton)
210-103 E	Cabinet, Ebony D 2386 (In carton)
210-103 R	Cabinet, Red D 2388 (In carton)
205-101	Insert Clear Radio
206-101 G	Gold Foil Face Radio
206-101 B	Blue Foil Face Radio
206-101 GR	Green Foil Face Radio
206-101 R	Red Foil Face Radio
220-104 E	Volume Control Knob Ebony
220-104 R	Volume Control Knob Red
220-104 WH	Volume Control Knob White
225-104 P	Cardboard Back
185-101	6 ft Line Cord
185-104	15 ft. Antenna Hank
170-105	4" PM Speaker with output Transformer

MODELS D1435A,
D1436A

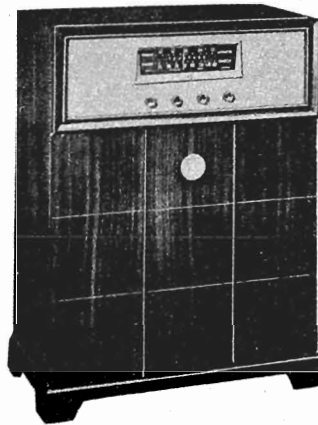

CHECK YOUR LINE VOLTAGE
Unless otherwise marked this radio must be operated on a supply of 105-125 volts AC, 60 cycles only. Do not connect the radio to a wall outlet unless certain that the power supply is correct for the receiver. If in doubt, telephone your local power company before inserting the plug. Radios of this model which are to be used on other power supplies are marked accordingly.

8 TUBES

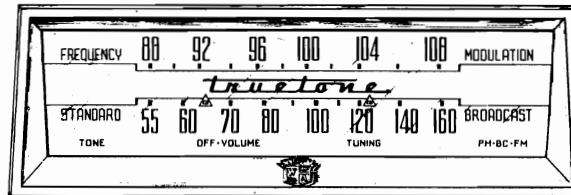

2 BANDS



FM BAND

88 - 108 MEGACYCLES
This band is calibrated in megacycles and covers the frequency modulation band of 88-108 megacycles. Reception in this band is usually limited to "line of sight" distances between the transmitting and receiving antennas. This is normally up to about 30 miles with approximately 45 miles being the extreme range.

BROADCAST BAND

540 - 1600 KILOCYCLES
This band is calibrated in channel numbers. To obtain the kilocycle number add a zero to the number on the dial scale.

TONE CONTROL

Use this knob to adjust the tone of the receiver. When turned clockwise the high notes will predominate and when turned counter-clockwise a deep bass effect will result.

BAND AND PHONO RADIO SWITCH

This control has three positions, FM, Broadcast and Phono. In the Phono position, the electrical circuits are connected for the reproduction of records played on the automatic record player.

ON-OFF SWITCH AND VOLUME CONTROL

The On-Off switch and Volume control are operated by the same knob. To turn the radio on, turn the knob clockwise until a click is heard. Allow approximately 30 seconds for the tubes to heat. Then continue to turn the knob clockwise to increase the volume.

TUNING KNOB

Use this control to tune in the desired station. Turn the knob until the station is heard. Then slowly rotate it back and forth until the signal is clearest and strongest. If signal is too strong, reduce it by means of the volume control, not by using the tuning knob.

MODELS D1435A,
D1436A

GENERAL INFORMATION

ANTENNA

Two antennas are incorporated in the receiver, a True-tone Stratoscope Loop Antenna for the broadcast range and a folded dipole antenna for the FM (frequency modulation) range. For the reception of local or powerful nearby stations, or in areas where the signal strength is good, usually no other antenna will be required. However, in some locations for the reception of FM stations, or distant stations in the broadcast band, an outside antenna is essential.

As the need for an external antenna varies in different locations, it is suggested that the radio be tried with the two antennas in order to determine if an external antenna is needed. If it is felt that an additional antenna is needed a folded dipole antenna with a 300 ohm line lead-in should be used. This type of antenna will increase the signal pickup on the FM band. Attach two terminal clips (packed in the literature envelope) to the lead-in of the outside FM antenna. Then connect the lead-in to the terminal strip at the rear of the receiver (see tube position illustration.)

It should be remembered in conjunction with the erection of an FM folded dipole antenna that FM reception is usually limited to "line of sight" distances or up to about 45 miles. Before erecting a special antenna for FM reception it is best to make certain that an FM station exists in your area.

For some locations FM reception may prove satisfactory with the dipole antenna but an external antenna may be needed for broadcast reception. For these ranges a terminal is attached to the loop antenna to which an external antenna may be connected. The antenna should be 50 to 60 feet long, with not more than 30 feet of lead-in and should be erected as high as possible and at right angles to the nearest electric lines.

NOTE: An external ground connection is not required.

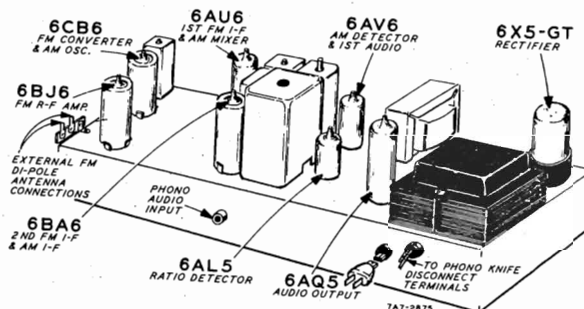

TUBES AND DIAL LAMP

The type designation of each tube is stamped on the tube and the radio chassis base. The correct positions in which the tubes must be installed are shown in the tube position illustration.

The tubes in the radio should be checked periodically by taking them out and having them tested.

When replacing the tubes, be sure that they are inserted in the proper sockets. To install a tube, insert the center guide pin into the center hole of the tube socket and turn the tube until the key drops into position. Then push the tube down until it is held firmly in the socket. To install a tube into a miniature type tube socket, line up the tube prongs with the holes in the socket and then gently push the tube down until it is held firmly in the socket. All tubes must be in their sockets to operate the radio. Use only No. 47 dial lamps.

IF THE RADIO FAILS TO OPERATE SATISFACTORILY

Recheck the foregoing instructions. If the radio still does not appear to operate satisfactorily, proceed as follows:

FIRST—Check Power Supply. Be sure there is power at the convenience outlet to which the radio is connected. To determine this, connect a lamp to the outlet and see whether or not the lamp lights.

Check the voltage and frequency of the power supply with that shown on the power rating label on the radio. If there is any doubt concerning the power supply, withdraw the plug from the outlet and consult the local power company before reinserting the plug.

SECOND—Check Tube Positions. See that the tubes are in the correct sockets as shown in the illustration.

Make certain that the tubes are operating. (Glass tubes will light very dimly.)

THIRD—Check Antenna. If an outside antenna is being used, inspect the antenna system to see that it is in good condition and not grounded at any point.

FOURTH—Test Tubes. Remove the tubes from the

radio, take them to your local radio dealer and have them tested either by means of a tube tester or by inserting them in a radio that is operating satisfactorily.

FIFTH—Service. If the radio does not function properly after the above procedure has been followed and the tubes have been tested, get in touch with the dealer from whom the radio was purchased or call in a competent radio technician.

FAULTY FM RECEPTION

The requirements for FM reception are more critical than for Standard band broadcast or short wave reception. This includes the area in which the receiver is located, the type of antenna used, the distance the receiver is located from the station to be received and other factors not encountered in Standard band broadcast reception. It is to be noted that reception in the high frequency FM band is usually limited to "line of sight" distances or up to about 45 miles. Also tall buildings or other structures between the transmitter and the receiver may be found to affect reception. Reception under these conditions will sometimes be helped by the addition of an external folded dipole antenna with a 300 ohm line lead-in. Information concerning this is given in the Antenna paragraph.

MODELS D1435A,
D1436A

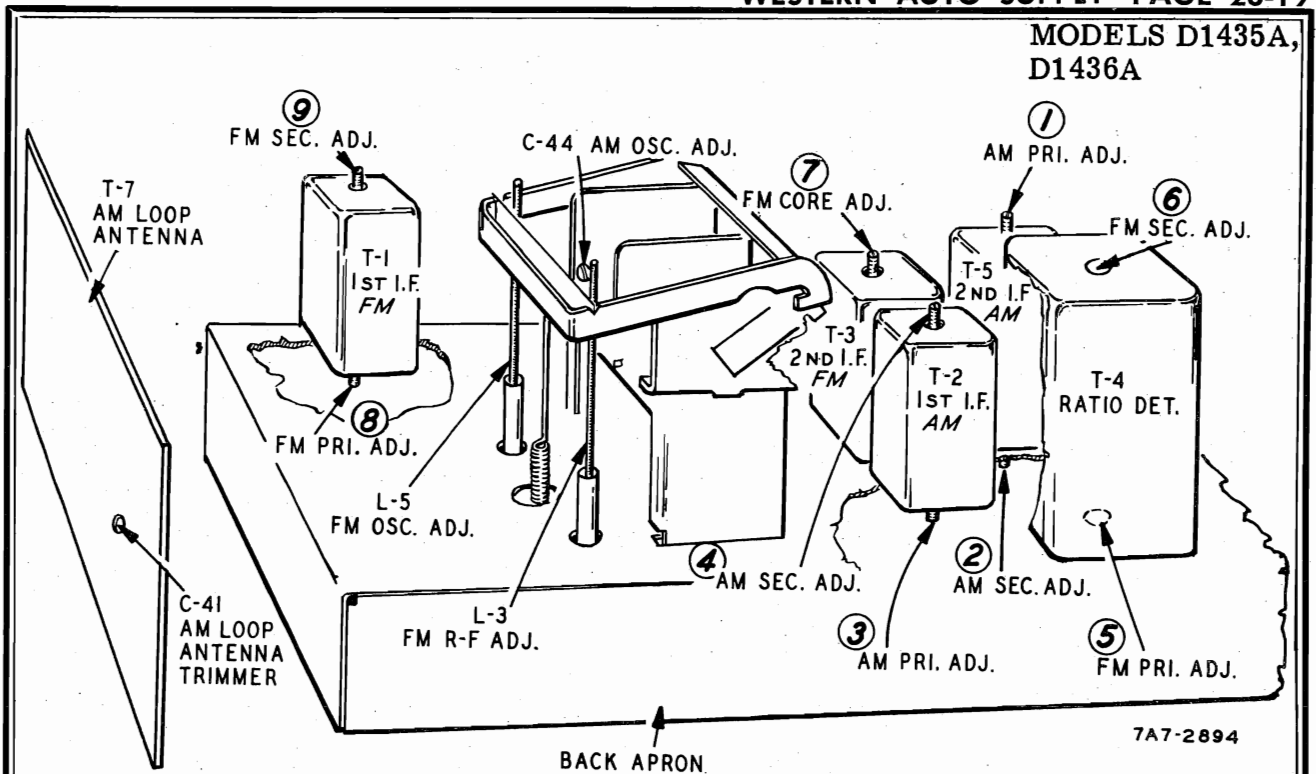

DRIVE CORD REPLACEMENT

Replacement of the drive cord may be accomplished as shown in the illustration. For this purpose use the new drive cord assembly listed in the Replacement Parts List. Turn the gang condenser until the plates are fully meshed. Then install the string as shown, winding three turns counter-clock-wise around the tuning shaft with the turns progressing away from the chassis. After the cord is installed, rotate the tuning shaft several times in order to take up any slack in the cord.

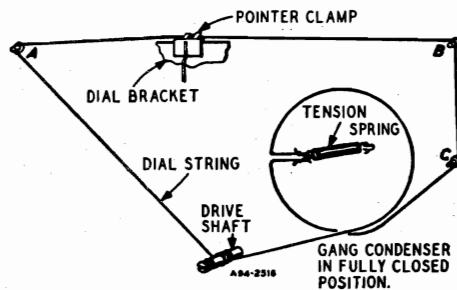

RECORD PLAYER CONNECTIONS

For models not equipped with built-in record player, a socket marked PHONO is provided on the back of the chassis for connection to an external record player or automatic record changer. When it is desired to play records through the radio, insert the connector on the cable of any standard record player into this socket. Turn the band switch to the phono position and use the volume control to adjust the sound level.

TUBE AND DIAL LAMP COMPLEMENT

1	6CB6	FM Converter and AM Oscillator
1	6BJ6	FM R-F Amplifier
1	6AU6	1st FM I-F and AM Mixer
1	6BA6	2nd FM I-F and AM I-F
1	6AV6	AM Detector and 1st Audio
1	6AL5	Ratio Detector
1	6AQ5	Audio Output
1	6X5-GT	Rectifier
2	No. 47	Dial Lamps

ELECTRICAL SPECIFICATIONS

Power Output -
117 volts AC-40 watts
60 cycles
60 watts phono operating

Power Output -
2.3 watts maximum
1.0 watts 10% distortion

Speaker - 6 inch PM dynamic

Frequency Ranges -
Broadcast 540-1600 KC
Frequency Modulation 88-108 MC

Intermediate Frequency -
AM 455 KC - FM 10.7 MC

Selectivity - AM - 45 KC broad at 1000 times signal,
Measured at 1000 KC
I.F. FM - 200 KC broad at 2 times down

AM Sensitivity - (For .5 watt output with external antenna)
15 microvolts average

FM Sensitivity - (For .5 watt output)
10 microvolts average

MODELS D1435A,
D1436A

**ALIGNMENT PROCEDURES
AM STAGES**

The following is required for aligning:

An All Wave Signal Generator Which Will Provide an Accurately Calibrated Signal at the Test Frequencies as Listed.

Output Indicating Meter, Non-Metallic Screwdriver, Dummy Antennas - .1 mf, and 50mmf.

Volume Control Maximum all Adjustments.

Connect Radio Chassis to Ground Post of Signal Generator with a Short Heavy Lead.

Allow Chassis and Signal Generator to "Heat Up" for Several Minutes.

SIGNAL GENERATOR				GANG CONDENSER SETTING	ADJUST	ADJUST FOR
FREQUENCY SETTING	CONNECT GENERATOR OUTPUT TO	THROUGH DUMMY ANTENNA	CONNECT GROUND TO			
455 KC	Control Grid 6BA6 Pin No. 1	.1mf	Chassis Base	Rotor Fully Open	2nd I.F. Pri. (1) and Sec. (2)	Maximum Output
455 KC	Control Grid 6AU6 Pin No. 1 1st Det.	.1 mf	Chassis Base	Rotor Fully Open	1st I.F. Pri. (3) and Sec. (4)	Maximum Output
455 KC	Control Grid 6AU6 Pin No. 1	.1 mf	Chassis Base	Rotor Fully Open	2nd I.F. Pri. (1) and Sec. (2)	Maximum Output
1620 KC	Control Grid 6AU6 Pin No. 1	.1 mf	Chassis Base	Rotor Fully Open	Oscillator C-44	Maximum Output
1400 KC	External Antenna Terminal	50 mmf	Chassis Base	Turn Rotor to Max. Output. Set Pointer to 1400 KC See Note A	Antenna C-41	Maximum Output

NOTE A-If the pointer is not at 1400 KC on the dial, reset pointer to the 1400 KC mark on the dial scale.

FM STAGES

The following is required for aligning:

An accurately calibrated signal generator providing unmodulated signals at the test frequencies listed below.

Dummy antennas, 5000 mmf and 300 ohms,

V.T.V.M. having a range of approximately 3 volts.

Allow chassis and signal generator to heat up for several minutes.

SIGNAL GENERATOR			BAND SWITCH SETTING	GANG CONDENSER SETTING	ADJUST	ADJUST FOR
FREQUENCY SETTING	CONNECT GENERATOR OUTPUT TO	THROUGH DUMMY ANTENNA				
10.7 MC	6BA6 Pin 1	5000 mmf	FM	Rotor Fully Open	Ratio Det. Pri. (5)	Maximum Deflection (Note 1)
10.7 MC	6BA6 Pin 1	5000 mmf	FM	Rotor Fully Open	Ratio Det. Sec. (6)	(Note 2)
10.7 MC	6AU6 Pin 1	5000 mmf	FM	Rotor Fully Open	2nd. I.F. Adj. (at top only) (7)	Maximum Deflection (Note 1)
10.7 MC	6BJ6 Pin 5	5000 mmf	FM	Rotor Fully Open	1st I.F. Adj. Pri. (8) and Sec. (9)-2nd I.F. Adj. (7) Ratio Det. Pri. (5) In order Shown	Maximum Deflection (Note 1)
10.7 MC	6BJ6 Pin 5	5000 mmf	FM	Rotor Fully Open	Ratio Det. Sec. (6)	(Note 2)
92 MC	FM Antenna Terminals	300 ohms	FM	Pointer to 92mc. on dial	Osc. Coil Adj. L-5	Maximum Deflection (Note 1)
92 MC	FM Antenna Terminals	300 ohms	FM	Pointer to 92mc on dial	R.F. Coil Adj. L-3	Maximum Deflection (Note 1)

FM ALIGNMENT NOTES

NOTE 1 - Connect V.T.V.M. common lead to chassis. Connect D.C. probe to Pin 7, of 6AL5. Input should be adjusted for approximately -3V. output.

NOTE 2 - Connect V.T.V.M. common lead to junction of R-14 and R-15. Connect D.C. probe to junction of R-13 and C-30. Adjust Ratio detector secondary for zero output.

MODELS D14 35A,
D1436A

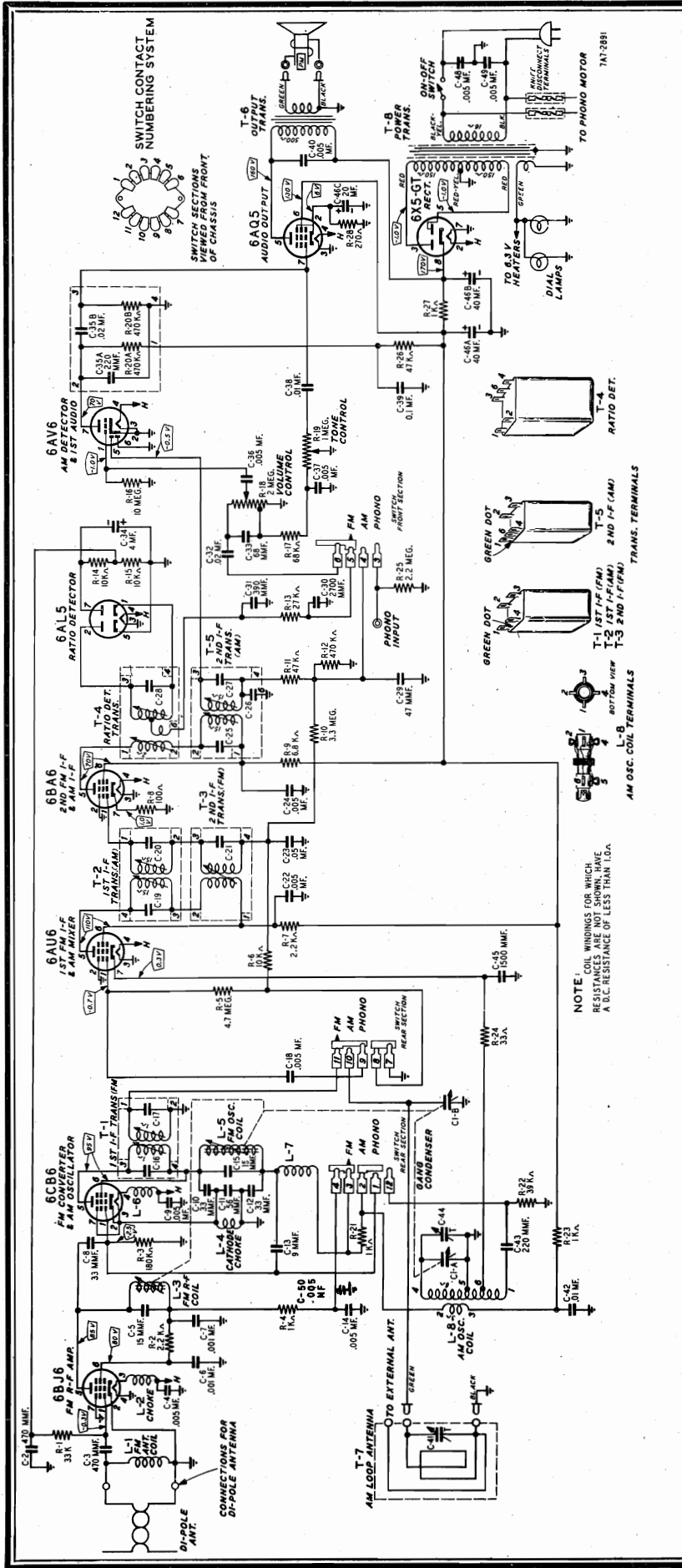

TUBE SOCKET VOLTAGES

Socket voltages are shown on the schematic diagram at the tube socket terminals. All voltages were taken with a VTVM and are between socket terminal and chassis ground with the bandswitch in the FM position. In the AM and Phono positions, plate and screen voltages, other than those of the 6BQ6, are slightly higher.

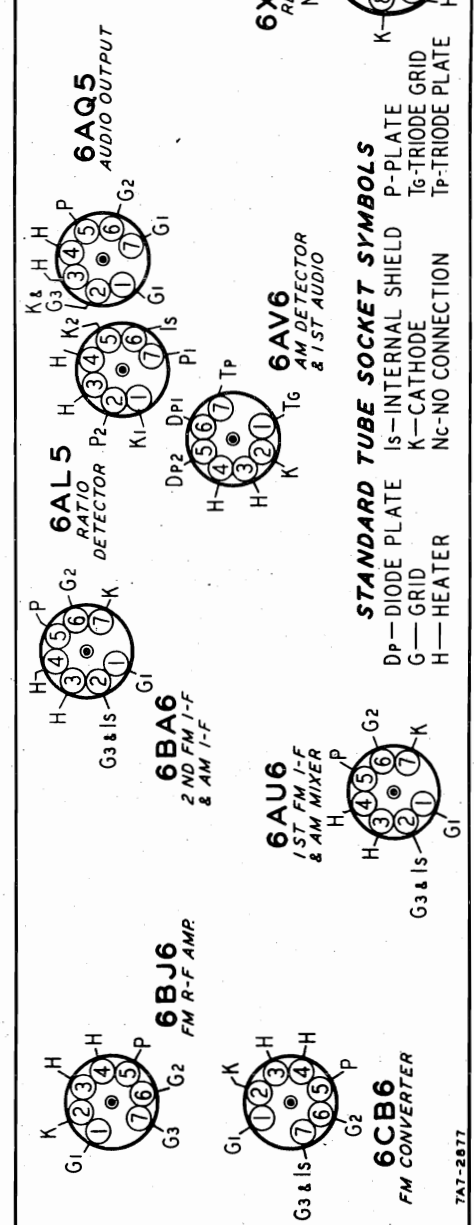

NOTE: COIL WINDINGS FOR WHICH RESISTANCE IS NOT SHOWN ARE A D.C. RESISTANCE OF LESS THAN 1.0 Ω.

MODELS D1435A,
D1436A

NOTICE: There is a model number label on the chassis. This label identifies the receiver as to chassis and issue letter. When ordering parts or writing, give ALL information on this label.

MISCELLANEOUS

12A509	6" P.M. Speaker	
4X1183	Escutcheon	
10A759	Knob (Mah)	
10A766	Knob (Beige)	
76X5	Resistor Capacitor Combination	
13X546	Line Cord and Plug Assembly	
2A437	Band Change Switch	
3A474	Tube Socket (Octal) (6X5)	
3A305	Phono Socket - Single Pin Tip	
3A426	Tube Socket (Miniature) (6AU6) (6AL5) (6AV6) (6AQ5)	
3A458	Tube Socket (Miniature) (6BA6)	
3A473	Tube Socket (Miniature) (6CB6) (6BJ6)	
32X403	Tube Shield (6BJ6) (6BA6) (6CB6)	
	Cabinet No. 454 (Mag.)	
	Cabinet No. 460 (Oak)	

CAPACITORS

C-1A	14A223-1	Gang Condenser and Pulley Assy. . . .	
C-1B			
C-2			
C-3	47X622	470 mmf	Ceramic
C-4			
C-9			
C-14			
C-18			
C-22	47X507	.005 mf	Ceramic
C-24			
C-36			
C-48			
C-49			
C-50			
C-5	47X617	15 mmf (Insulated)	Ceramic
C-6			
C-7	80X1	.001 mf	Ceramic
C-8			
C-10	47X619	.33 mf	Ceramic
C-12			
C-11	47X625	56 mmf	Ceramic
C-13	47X616	9 mmf	Ceramic
C-15	47X618	15 mmf (Non-Ins.)	Ceramic
C-16			
C-17		Part of T-1 (1st I-F Trans. F.M.)	
C-19			
C-20		Part of T-2 (1st I-F Trans. A.M.)	
C-21			
C-23		Part of T-3 (2nd I-F Trans. F.M.)	
C-25		RCP 10W2503M .05 mf 200V	Tubular
C-26			
C-27		Part of T-5 (2nd I-F Trans. A.M.)	
C-28		Part of T-4 (Ratio Det.)	
C-29	47X509	47 mmf	Ceramic
C-30	47X575	2700 mmf	Ceramic
C-31	47X623	390 mmf	Ceramic
C-32	RCP 10W2203M	.02 mf 200V	Tubular
C-33	47X471	68 mmf	Ceramic
C-34	45X361	4 mf 100V -Dry Electrolytic	..
C-35A			
C-35B		Part of 76X5 (See Miscellaneous)	
C-37	RCP 10W2502M	.005 mf 200V	Tubular
C-38			
C-42	RCP 10W2103M	.01 mf 200V	Tubular
C-39	RCP 10W4104M	.1 mf 400V	Tubular
C-40	RCP 10W8502M	.005 mf 800V	Tubular
C-41	17A256	2-24 mmf	Trimmer
C-43	47X621	220 mmf	Ceramic
C-45	47X545	1500 mmf	Ceramic
C-46A		40 mf 200V	
C-46B	45X406	40 mf 200V Dry Electrolytic	..
C-46C		20 mf 25V	

RESISTORS

		Ohms	Watts	
R-1	B85333	33K	0.5	Carbon
R-2	B85222	2.2K	0.5	Carbon
R-3	B84184	180K	0.5	Carbon
R-4				
R-21	B85102	1K	0.5	Carbon
R-23				
R-5	B85475	4.7 meg.	0.5	Carbon
R-6				
R-14	B84103	10K	0.5	Carbon
R-15				
R-7	B84222	2.2K	0.5	Carbon
R-8	B84101	100	0.5	Carbon
R-9	B84682	6.8K	0.5	Carbon
R-10	B85335	3.3 meg.	0.5	Carbon
R-11	B85473	47K	0.5	Carbon
R-26				
R-12	B84474	470K	0.5	Carbon
R-13	B85273	27K	0.5	Carbon
R-16	B85106	10.0 meg.	0.5	Carbon
R-17	B85683	68K	0.5	Carbon
R-18	36X389	2.0 meg.		Volume Control
R-19	40X341	1.0 meg.		Tone Control ..
R-20A				
R-20B		Part of 76X5 (See Miscellaneous)		
R-22	B84393	39K	0.5	Carbon
R-24	B84330	33	0.5	Carbon
R-25	B85225	2.2 meg	0.5	Carbon
R-27	D84102	1K	2.0	Carbon
R-28	B84271	270	0.5	Carbon

TRANSFORMERS AND COILS

L-1	9A2305	Antenna Coil (F.M.)
L-2	9A2304	Filament Choke
L-3	9A2300	R-F. Coil (F.M.)
L-4	9A2306	Converter Cathode Choke
L-5	9A2305	Oscillator Coil (F.M.)
L-6	9A2303	Filament Choke
L-7	35A9	Choke
L-8	9A2302	Oscillator Coil (A.M.)
T-1	9A2310	1st I-F Trans. (F.M.)
T-2	9A2308	1st I-F Trans. (A.M.)
T-3	9A2309	2nd I-F Trans. (F.M.)
T-4	9A2260	Ratio Det. Trans.
T-5	9A2307	2nd I-F Trans. (A.M.)
T-6	51X162	Output Transformer
T-7	9A2311	"B" Range Loop Antenna
T-8	53X291	Power Transformer

DIAL AND DRIVE ASSEMBLY

58X774	Dial Glass
15X260	Pointer
19X192	"C" Washer (Mtg. Drive Shaft)
6X66	Rubber Grommet
25X1616	Dial Bracket
28X113	Drive Cord Tension Spring
7A103	No. 47 Pilot Light
7A199	Pilot Light Socket Assembly
10X90	Drive Cord Assembly
26X522	Drive Shaft

TYPE V-28A187 RECORD CHANGER PARTS

See Note	Motor Assembly, 60 Cycles
	105-125 Volts AC
V-2503G	Pickup Arm
10L3-J	Astatic Cartridge Complete with Needles ..
A1-J	Needle (1 Mil)
A3-J	Needle (3 Mil)

NOTE: Specify part number stamped on motor assembly.

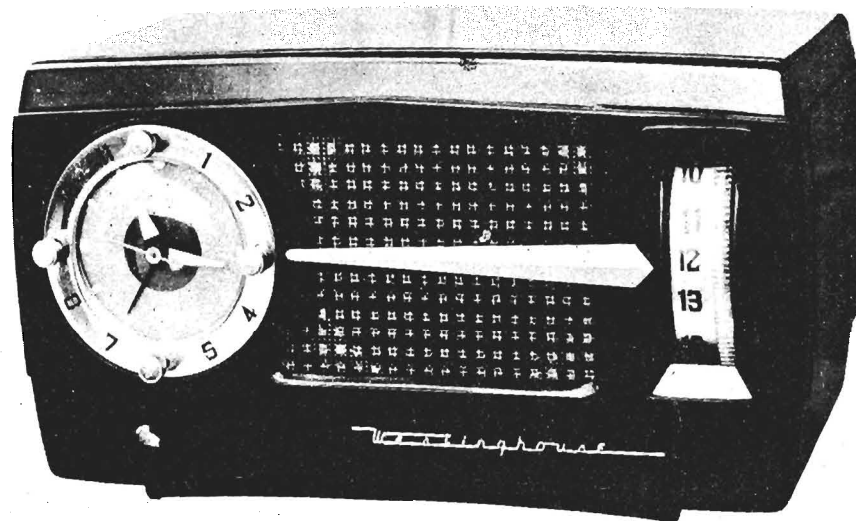
MODELS H-355T5,
H-356T5; Ch. V-2157-5

SERVICE NOTES

SPECIFICATIONS

FREQUENCY RANGE: 540 to 1615 kc.

INTERMEDIATE FREQUENCY: 455 kc.

TUBE COMPLEMENT:

1 12BE6 Converter
 1 12BA6 I-F Amp.
 1 12AV6 Det., AVC, and 1st A-F Amp.
 1 50C5 Output Amp.
 1 35W4 Rectifier

POWER OUTPUT:

Undistorted 0.9 watt
 Maximum 1.5 watts

LOUDSPEAKER: 4" P.M.

OPERATING VOLTAGE: 105 to 120 volts, 60 cycles A-C

POWER CONSUMPTION:

Radio 35 watts
 Clock 2.5 watts

ALIGNMENT

It is recommended that the chassis be isolated from the power line by means of an isolation transformer.

Make certain that the dial pointer is correctly positioned.

While making the following adjustments, keep the volume control set for maximum output and the signal generator output attenuated to avoid AVC action.

Step	Connect Signal Generator to —	Signal Generator Frequency	Radio Dial	Adjust for Maximum Output —
1.	Stator of ant. tuning capacitor (A) through a 200 mmf capacitor	455 kc.	Minimum capacity	Top and bottom slugs of T2 and T1 in order given*
2.	Same as step 1	1615 kc.	Minimum capacity	Oscillator trimmer (D)
3.	Radiated signal	1400 kc.	1400 kc.	Antenna trimmer (B)

*It is recommended that a fiber aligning tool that snugly fits the slot in the powdered iron core be used to prevent chipping of the slot.

9-51 Form RM3256

MODELS H-355T5,
H-345T5; Ch. V-2157-5

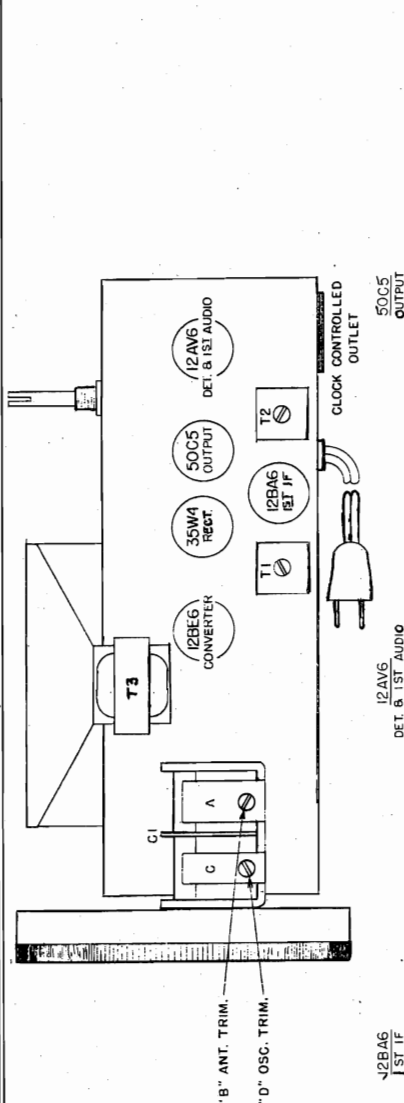

FIG. 2 - CHASSIS LAYOUT

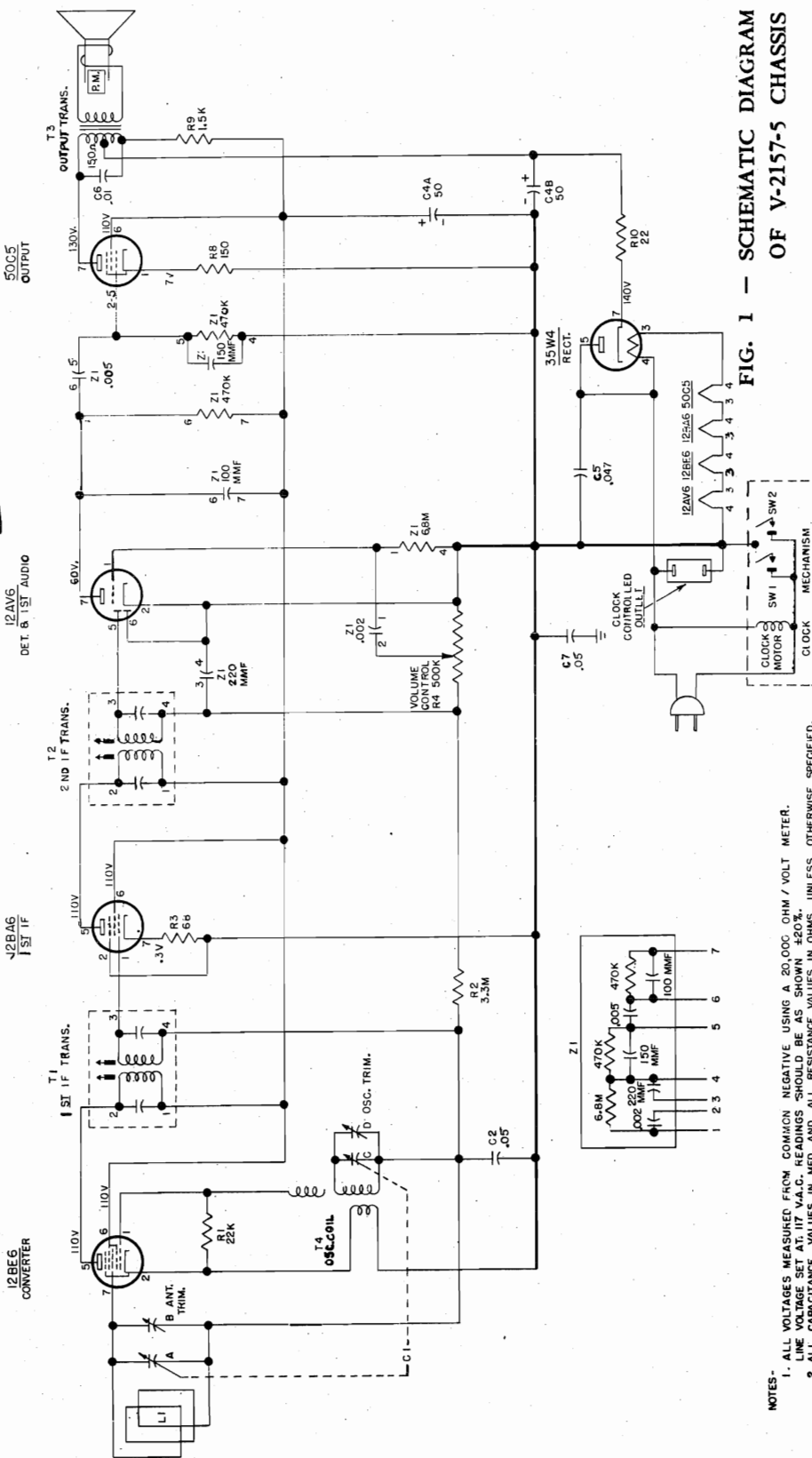

FIG. 1 - SCHEMATIC DIAGRAM OF V-2157-5 CHASSIS

NOTES -
1. ALL VOLTAGES MEASURED FROM COMMON NEGATIVE USING A 20,000 OHM / VOLT METER.
LINE VOLTAGE SET AT 117 V.A.C. HEADINGS SHOULD BE AS SHOWN ±20%.
2. ALL CAPACITANCE VALUES IN MFD. AND ALL RESISTANCE VALUES IN OHMS, UNLESS OTHERWISE SPECIFIED.

PRODUCTION CHANGES IN V-2157-5 CHASSIS

WIRING CHANGE TO PREVENT "MOTORBOATING" — In later production, a possible cause of motorboating is eliminated by a slight rearrangement of wiring. The changes, which are physical in nature and involve no schematic changes, are illustrated at the right. If motorboating occurs in a chassis that does not contain the change, proceed as follows:

1. Remove the wire that is connected between pin #6 of the 50C5 and the 2nd I-F transformer.
2. Disconnect lead #7 of the multiple capacitor and resistor assembly (Z1) from the 2nd I-F transformer, and connect it to pin #6 of the 50C5 socket.
3. Connect an insulated wire between pin #6 of the 50C5 socket and pin #6 of the 12BE6 socket.

INCREASE IN WATTAGE OF R10 — In later production, the wattage of R10 (22 ohms) is increased from ½ w. to 1 w. to prevent resistor burn-

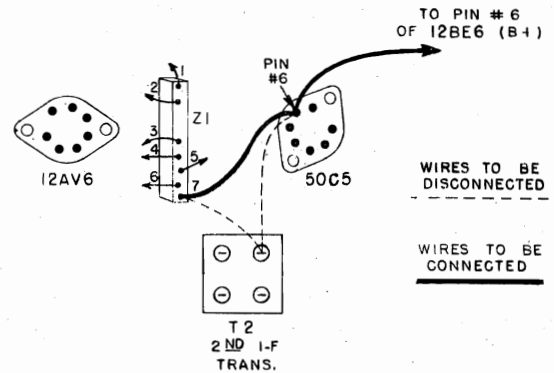

BOTTOM VIEW OF V-2157-5 CHASSIS SHOWING CHANGE TO ELIMINATE "MOTORBOATING"

out. The part number of the 1 watt resistor is RC30AE220M, and its list price is \$0.10. The parts list should be changed accordingly.

PARTS LIST FOR MODELS H-355T5 AND H-356T5

When ordering parts, specify model number of set in addition to part number and description of part.

CABINET AND MISCELLANEOUS

Part No.	Description	List Price Each
V-1248-1	Cabinet, H-355T5 (less front grille, baffle and pointer)	\$5.75*
V-1248-2	Cabinet, H-356T5 (less front grille, baffle and pointer)	5.75*
V-5426	Clip, I-F mounting	.03
V-10783-2	Dial	.90
V-10782-1	Grille, front	.60
V-10784-1	Knob, volume (H-355T5)	.10
V-10784-2	Knob, volume (H-356T5)	.10
V-10774-4	Pointer (H-355T5)	.55
V-10774-5	Pointer (H-356T5)	.55
V-10052	Shield, chassis bottom	.45
V-9888-2	Socket, 12BE6, 50C5, 35W4	.12
V-9888-3	Socket, 12AV6, 12BA6	.14
V-5405	Socket, molded power (clock controlled AC)	.28
V-10079-2	Speaker, 4" PM (includes T3)	5.50*

V-2157-5 CHASSIS

Ref. No.	Part No.	Description	List Price Each
C1	V-10788-1	Capacitor, variable	\$2.50
C2	RCP10W2503M	Capacitor, .05 mfd 200 v.	.20
C4	V-9991	Capacitor, electrolytic, 50-50 mfd 150 v.	1.65
C5	V-10157-4473M	Capacitor, .047 mfd 400 v.	.30
C6	RCP10W4103M	Capacitor, .01 mfd 400 v.	.20
C7	RCP10W4503M	Capacitor, .05 mfd 400 v.	.24
L1	V-10785-1	Loop, antenna	1.25*
R1	RC20AE223M	Resistor, 22,000 ohms ½ w.	.05
R2	RC20AE335M	Resistor, 3.3 megohm ½ w.	.05
R3	RC20AE680M	Resistor, 68 ohms ½ w.	.05
R4	V-9993-5	Control, volume, 500,000 ohms	.80
R8	RC20AE151M	Resistor, 150 ohms ½ w.	.06
R9	RC30AE152M	Resistor, 1500 ohms 1 w.	.30
R10	RC20AE220M	Resistor, 22 ohms ½ w.	.07
T1	V-9735-1	Transformer, I-F	1.25
T2	V-9735-1	Transformer, I-F	1.25
T3	V-10079-2	Transformer, audio (includes speaker)	5.50*
T4	V-9992	Transformer, oscillator	.55
Z1	V-10789-1	Multiple capacitor and resistor assembly	.90

*Price includes Federal Excise Tax

NOTE: All prices are subject to change without notice

MODEL H-357C10,
Ch. V-2180-5

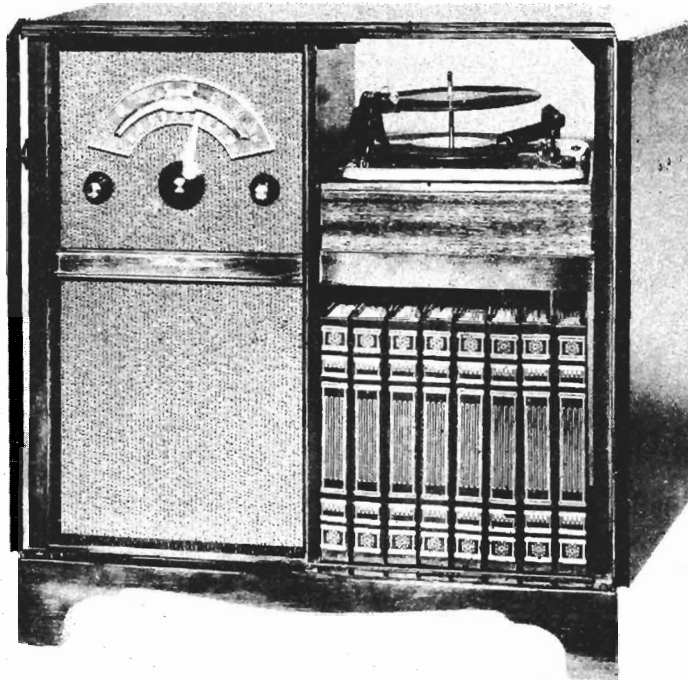

SERVICE NOTES

SPECIFICATIONS

FREQUENCY RANGES:

Amplitude Modulation 540 to 1615 kc.
Frequency Modulation 88 to 108 mc.

1 6C4 Phase Inverter
2 6V6GT Output Amp.
1 5Y3GT Rectifier

INTERMEDIATE FREQUENCIES:

Amplitude Modulation 455 kc.
Frequency Modulation 10.7 mc.

POWER OUTPUT:

Undistorted 6.5 watts
Maximum 7.5 watts

TUBE COMPLEMENT:

1 6BJ6 RF Amplifier (FM)
1 12AT7 Mixer-osc.
2 6BA6 I-F Amp.
1 6AL5 Ratio Det. (FM)
1 6AV6 Det. and AVC (AM) and A-F Amp.

LOUDSPEAKER: 10" PM

OPERATING VOLTAGE:

..... 105 to 120 volts, 60 cycles AC

POWER CONSUMPTION (radio): 75 watts

ALIGNMENT BROADCAST BAND

Connect an output meter across the speaker voice coil.

While making the following adjustments, keep the volume control set for maximum output, the tone control set for maximum treble, and the signal generator output attenuated to avoid AVC action.

Step	Connect Signal Generator to —	Signal Generator Frequency	Radio Dial Setting	Adjust
1	Set the band switch to AM.			
2	Stator of tuning capacitor (A) through 0.1 mfd capacitor	455 kc.	minimum capacity	Pri. and sec. of T7 and T6 for max. output in order given
NOTE: If the I-F transformers are badly mis-aligned, it may be impossible to obtain sufficient output using the above system. In this event, it will be necessary to align each transformer separately. Start with the last I-F transformer and work forward, connecting the signal generator to the control grid of the tube preceding the transformer under alignment.				
3	Radiated signal (no actual connection)	1615 kc.	minimum capacity	AM osc. trimmer (D) for max. output
4	Radiated signal (no actual connection)	1400 kc.	tune to signal	AM ant. trimmer (B) for max. output (rock-in adjustment)

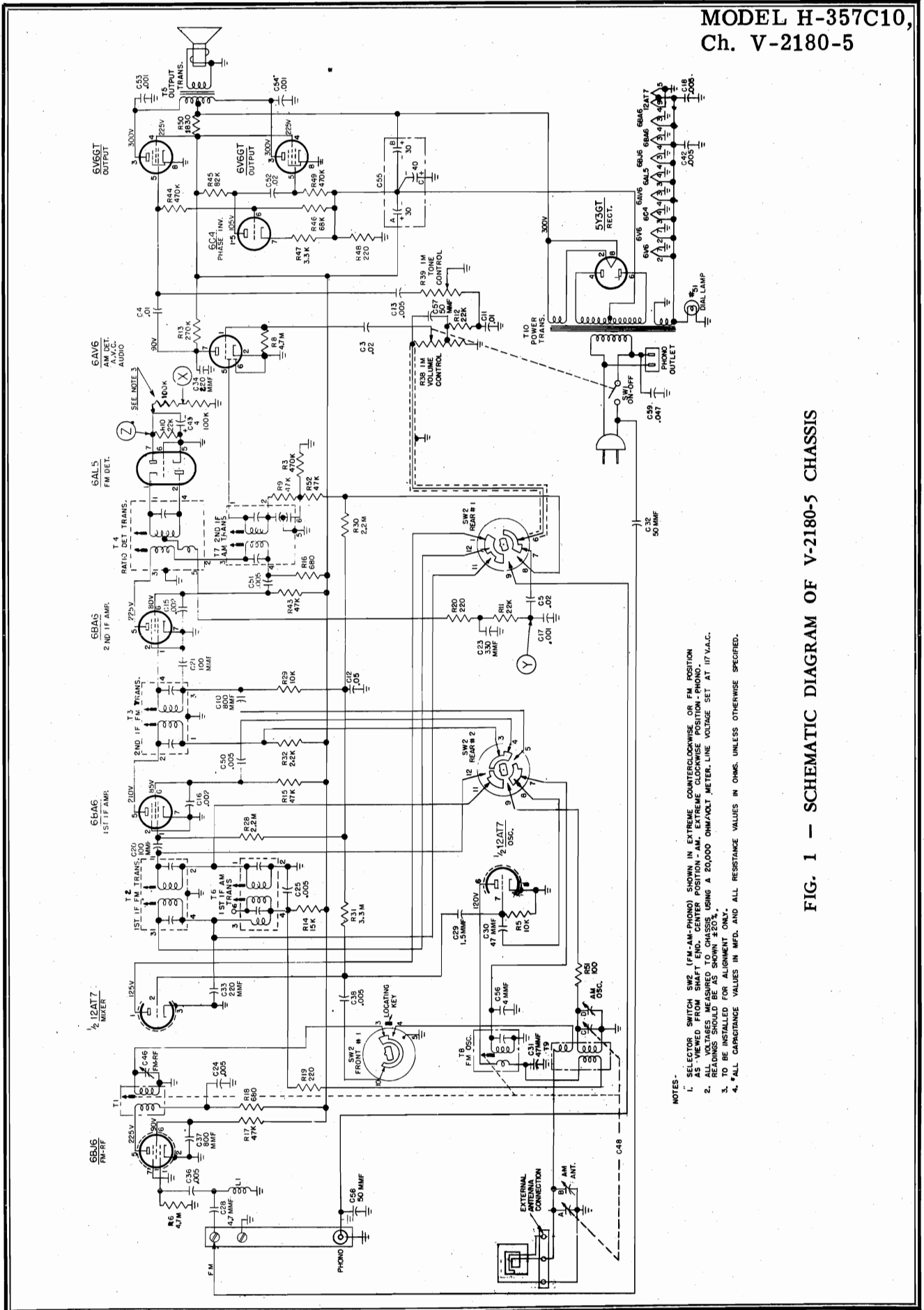

- NOTES -
1. SELECTOR SWITCH SW2 (FM-AM-PHONO) SHOWN IN EXTREME COUNTERCLOCKWISE OR FM POSITION AS VIEWED FROM SHAFT END. CENTER POSITION - AM, EXTREME CLOCKWISE POSITION - PHONO.
 2. READINGS SHOULD BE TAKEN WITH CHASSIS SHOWN USING A 20,000 OHM/VOLT METER. LINE VOLTAGE SET AT 117 V.A.C.
 3. TO BE INSTALLED FOR ALIGNMENT ONLY.
 4. *ALL CAPACITANCE VALUES IN MFD. AND ALL RESISTANCE VALUES IN OHMS, UNLESS OTHERWISE SPECIFIED.

FIG. 1 - SCHEMATIC DIAGRAM OF V-2180-5 CHASSIS

MODEL H-357C10,
Ch. V-2180-5

FM BAND

Do not align the FM circuits until all AM adjustments have been completed.

Step	Connect Signal Generator to —	Signal Generator Frequency	Radio Dial Setting	Adjust
1	Set the band switch to FM			
2	Connect two 100,000 ohm resistors (the resistances must be equal within 5 per cent) between pin No. 7 of the 6AL5 tube and ground as shown on the schematic diagram.			
3	Connect a V.T.V.M. between points "X" and "Y" (see schematic diagram).			
4	Pin No. 2 of 12AT7 through a .01 mfd mica capacitor	10.7 mc.	minimum capacity	Sec. of T4 for zero (use medium strength signal)
5	Connect the V.T.V.M. between point "Z" and ground			
6	Same as step 4	10.7 mc.	minimum capacity	Pri. of T4 and pri. and sec. of T3 and T2 for max.
7	Reconnect the V.T.V.M. between points "X" and "Y" and increase the signal strength 10 times.			
8	Same as step 4	10.7 mc.	minimum capacity	Recheck sec. of T4 for zero voltage
9	Reconnect the V.T.V.M. between point "Z" and ground			
10	Same as step 4	10.7 mc.	minimum capacity	Pri. of T4 for maximum voltage
11	Remove the two 100,000 ohm resistors that were inserted in step 2			
12	FM ant. terminal through a 300 ohm non-inductive resistor	98 mc.	98 mc.	FM osc. core for maximum voltage
13	Same as step 12	98 mc.	98 mc.	FM R-F trimmer (C46) for maximum voltage
14	Same as step 12	105 mc.	tune to signal	FM R-F core for maximum voltage
15	Same as step 12	90 mc.	tune to signal	FM R-F trimmer (C46) for maximum voltage (rock-in)
16	Recheck steps 14 and 15 for tracking			

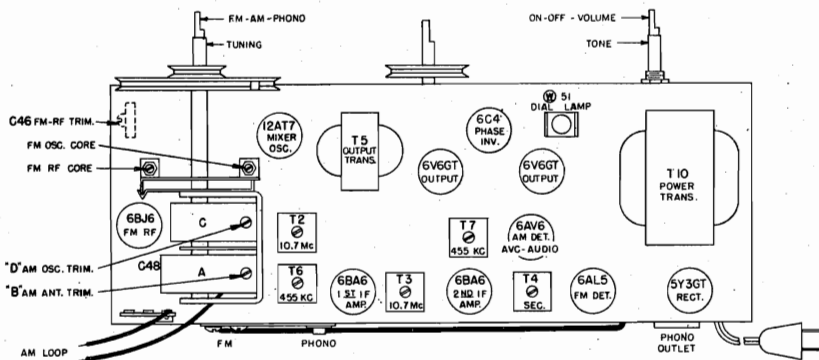

FIG. 2 - TOP VIEW OF CHASSIS

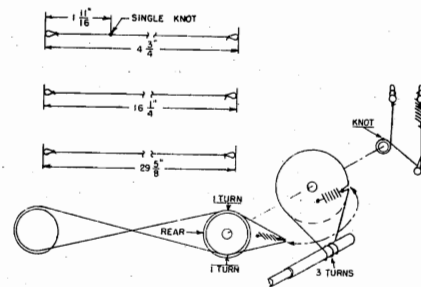

FIG. 3 - DIAL DRIVE

PARTS LIST FOR MODEL H-357C10

When ordering parts, specify model number of set in addition to part number and description of part.

CABINET AND MISCELLANEOUS

Part No.	Description	List Price Each		
V-1230-1	Cabinet	\$87.10**	V-9845-1	Cover, back (record changer)50
V-6415-4	Cable, phono pickup55	V-10308-1	Dial
V-4898-1	Catch, bullet06	V-8576	Doors, matched pair (less hardware) 35.00
V-5426	Clip, IF mounting03	V-8577	Drawer, record changer (complete) 12.50
V-3219S-1	Cord, dial drive (100' spool)	1.40	V-10604-1	Escutcheon, dial
				1.30

MODEL H-357C10,
Ch. V-2180-5

Part No.	Description	List Price Each	Ref. No.	Part No.	Description	List Price Each
V-10307-1	Grille assembly	5.00	C50	V-5596	Capacitor, .005 mfd	.25
V-9091-1	Hinge, upper L.H. and lower R.H.	.30	C51	V-5596	Capacitor, .005 mfd	.25
V-9091-2	Hinge, upper R.H. and lower L.H.	.30	C52	RCP10W4203M	Capacitor, .02 mfd 400 v.	.18
V-10338-1	Hub, pointer	.65	C53	RCP10W6102M	Capacitor, .001 mfd 600 v.	.18
V-9104-9	Knob, tuning (rear)	.20	C54	RCP10W6102M	Capacitor, .001 mfd 600 v.	.18
V-10408-5	Knob, band	.35	C55	V-10806-1	Capacitor, elec., 30-30 mfd 400 v. and 40 mfd 25 v.	3.00
V-10408-2	Knob, off-on-volume	.30	C56	R2CC20UJ040D	Capacitor, 4 mmf	.30
V-9104-10	Knob, tone (rear)	.25	C57	V-5658-10	Capacitor, 50 mmf	.13
No. 51	Lamp, pilot	.08	C58	V-5658-10	Capacitor, 50 mmf	.13
V-10808-1	Loop, AM antenna	\$ 1.50	C59	V-10157-4473M	Capacitor, .047 mfd 400 v.	.30
V-10318-2	Nameplate, Westinghouse	.60		V-9676-1	Core, FM tuning	.55
V-10310-1	Pointer, dial	.70	L1	V-10644-1	Reactor, RF	.15
V-4967	Pull, door	.60	R3	RC20AE474K	Resistor, 470,000 ohms 1/2 w.	.05
V-10815-1	Pulley and shaft assy., pointer	.50	R5	RC20AE103M	Resistor, 10,000 ohms 1/2 w.	.05
V-10357-1	Pulley assy., gang	.35	R6	RC20AE475M	Resistor, 4.7 megohms 1/2 w.	\$.05
V-10038-1	Shield, miniature tube (6BJ6)	.06	R8	RC20AE475M	Resistor, 4.7 megohms 1/2 w.	.05
V-10649-1	Shield, miniature tube (12AT7)	.30	R9	RC20AE473M	Resistor, 47,000 ohms 1/2 w.	.05
V-10133-2	Socket, miniature wafer (12AT7)	.60	R10	RC20AE223K	Resistor, 22,000 ohms 1/2 w.	.06
V-3246S	Socket, octal wafer (6V6GT)	.21	R11	RC20AE223M	Resistor, 22,000 ohms 1/2 w.	.05
V-9888-1	Socket, miniature wafer (all 7-pin tubes)	.13	R12	RC20AE223M	Resistor, 22,000 ohms 1/2 w.	.05
V-4514-1	Socket, molded octal (5Y3GT)	.17	R13	RC20AE274K	Resistor, 270,000 ohms 1/2 w.	.06
V-5405	Socket, phono AC	.28	R14	RC30AE153K	Resistor, 15,000 ohms 1 w.	.11
V-10809-1	Socket, pilot lamp	.35	R15	RC20AE473M	Resistor, 47,000 ohms 1/2 w.	.05
V-9770-1	Speaker, 10" PM	8.00**	R16	RC20AE681M	Resistor, 680 ohms 1/2 w.	.06
V-6795-3	Spring, dial drive	.03	R17	RC20AE473M	Resistor, 47,000 ohms 1/2 w.	.05
V-4900-1	Strike, bullet	.03	R18	RC20AE681M	Resistor, 680 ohms 1/2 w.	.06
V-6136	Terminal board, antenna-phonos	.26	R19	RC20AE221M	Resistor, 220 ohms 1/2 w.	.05
			R20	RC20AE221M	Resistor, 220 ohms 1/2 w.	.05
			R28	RC20AE225M	Resistor, 2.2 megohms 1/2 w.	.06
			R29	RC20AE103M	Resistor, 10,000 ohms 1/2 w.	.05
			R30	RC20AE225M	Resistor, 2.2 megohms 1/2 w.	.06
			R31	RC20AE335M	Resistor, 3.3 megohms 1/2 w.	.05
			R32	RC20AE222M	Resistor, 2200 ohms 1/2 w.	.05
			R38	V-10330-2	Control, volume, 1 meg. (assy consists of R38, R39 & SW1)	2.35
			R39	V-10330-2	Control, tone, 1 meg. (assy consists of R38, R39 & SW1)	2.35*
			R43	RC20AE473M	Resistor, 47,000 ohms 1/2 w.	.05
			R44	RC20AE474M	Resistor, 470,000 ohms 1/2 w.	.04
			R45	RC20AE823K	Resistor, 82,000 ohms 1/2 w.	.05
			R46	RC20AE683K	Resistor, 68,000 ohms 1/2 w.	.05
			R47	RC20AE332J	Resistor, 3300 ohms 1/2 w.	.15
			R48	RC40AE221K	Resistor, 220 ohms 2 w.	.20
			R49	RC20AE474M	Resistor, 470,000 ohms 1/2 w.	.04
			R50	V-6984-16	Resistor, 1830 ohms 5 w.	.35
			R51	RC20AE101M	Resistor, 100 ohms 1/2 w.	.05
			R52	RC20AE473M	Resistor, 47,000 ohms 1/2 w.	.05
			SW1	V-10330-2	Switch, on-off (assy consists of R38, R39 and SW1)	2.35
			SW2	V-10810-1	Switch, FM-AM-PHONO selector	2.55
			T1	V-10642-1	Transformer, FM RF	.85
			T2	V-9688	Transformer, 1st FM IF	1.50
			T3	V-9642	Transformer, 2nd FM IF	1.50
			T4	V-9828	Transformer, ratio detector	2.05
			T5	V-10813	Transformer, audio	2.00
			T6	V-10619	Transformer, 1st AM IF	2.20
			T7	V-10350-1	Transformer, 2nd AM IF	1.35
			T8	V-10643-1	Transformer, FM oscillator	1.30
			T9	V-10944-1	Transformer, AM oscillator	.90
			T10	V-10811	Transformer, power (replacement for V-6667 or V-10811)	11.10

V-2180-5 CHASSIS

Ref. No.	Part No.	Description	List Price Each
C3	RCP10W2203M	Capacitor, .02 mfd 200 v.	\$.20
C4	RCP10W2103M	Capacitor, .01 mfd 200 v.	.20
C5	RCP10W2203M	Capacitor, .02 mfd 200 v.	.20
C10	V-9863-1	Capacitor, 800 mmf	.20
C11	RCP10W4103M	Capacitor, .01 mfd 400 v.	.20
C12	RCP10W2503M	Capacitor, .05 mfd 200 v.	.20
C13	RCP10W4502M	Capacitor, .005 mfd 400 v.	.17
C15	RCP10W6202M	Capacitor, .002 mfd 600 v.	.17
C16	RCP10W6202M	Capacitor, .002 mfd 600 v.	.17
C17	RCP10W6102M	Capacitor, .001 mfd 600 v.	.17
C18	V-5596	Capacitor, .005 mfd	.25
C20	R4CC21YY101M	Capacitor, 100 mmf	.19
C21	R4CC21YY101M	Capacitor, 100 mmf	.19
C23	RCM30A331M	Capacitor, 330 mmf	.25
C24	V-5596	Capacitor, .005 mfd	.25
C25	V-5596	Capacitor, .005 mfd	.25
C28	V-9926-3	Capacitor, 4.7 mmf	.07
C29	V-5658-9	Capacitor, 1.5 mmf	.07
C30	R2CC30RK470K	Capacitor, 47 mmf	.30
C31	V-10710-1	Capacitor, 47 mmf	.19
C32	V-5658-10	Capacitor, 50 mmf	.13
C33	V-10710-2	Capacitor, 220 mmf	.19
C34	V-10710-2	Capacitor, 220 mmf	.19
C36	V-5596	Capacitor, .005 mfd	.25
C37	V-9863-1	Capacitor, 800 mmf	.20
C38	V-5596	Capacitor, .005 mfd	.25
C42	V-5596	Capacitor, .005 mfd	.25
C43	V-4637	Capacitor, elec. 4 mfd 50 v.	.85
C46	V-10640-1	Capacitor, FM RF trimmer	.25
C48	V-10662-1	Capacitor, variable (A, B, C and D)	2.95

*Sold only as complete assembly. Price shown covers complete assembly.
**Price includes Federal Excise Tax.
NOTE: All prices are subject to change without notice.

Form RM3257
9-51

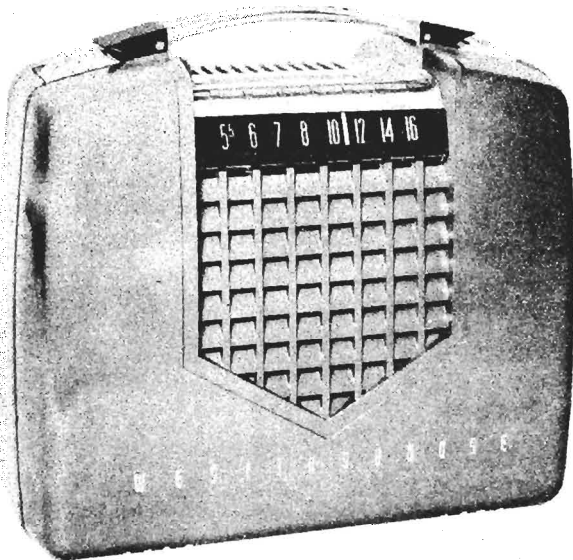

SPECIFICATIONS

FREQUENCY RANGE: 540 to 1615 kc.

INTERMEDIATE FREQUENCY: 455 kc.

TUBE COMPLEMENT:

- 1 1R5 Converter
- 1 1U4 I-F Amp.
- 1 1U5 Det., AVC and 1st A-F Amp.
- 1 3V4 Power Output Amp.

POWER OUTPUT:

Maximum 0.23 watt

Undistorted 0.12 watt

POWER SUPPLY:

Battery Operation:

- 1 "A" Battery (4.5 v.) — Eveready 736, Ray-O-Vac P93A, or Burgess F3
- 1 "B" Battery (90 v.) — Eveready 490, Ray-O-Vac 4390, or Burgess N60

Line Operation:

105 to 120 volts, 50 - 60 cycles A-C; or D-C

CURRENT CONSUMPTION (Battery Operation):

"A" Battery 0.1 Amp.

"B" Battery 0.014 Amp.

POWER CONSUMPTION (Line Operation):

..... 15 watts

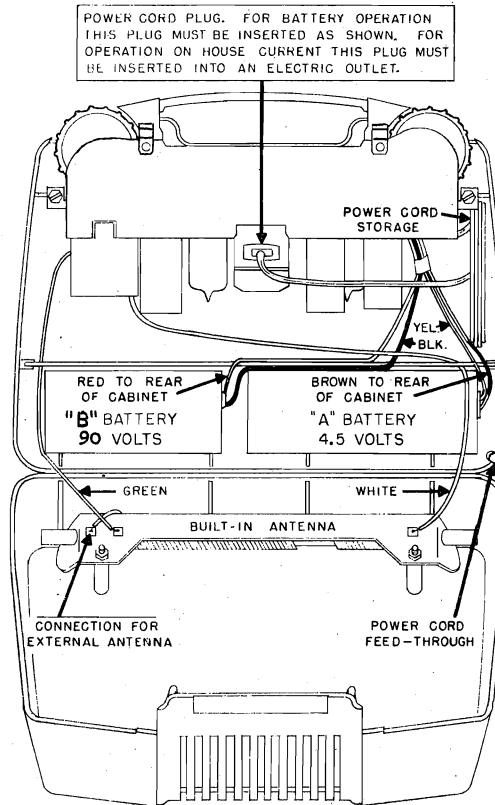

FIG. 1 - REAR VIEW WITH COVER OPEN

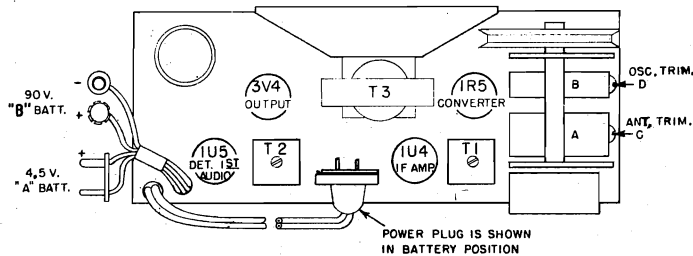

FIG. 2 - CHASSIS LAYOUT

ALIGNMENT

It is recommended that the chassis be isolated from the power line by means of an isolation transformer.

While making the following adjustments, keep the volume control set for maximum output and the signal generator output attenuated to avoid AVC action.

Step	Connect Signal Generator to —	Signal Generator Frequency	Radio Dial	Adjust for Maximum Output —
1	Stator of R-F tuning capacitor (A) through a 0.1 mfd	455 kc.	minimum capacity	Top and bottom slugs in 2nd and 1st I-F trans. in order given*
2	Same as step 1	1615 kc.	minimum capacity	Osc. trimmer (D)
3	Radiated Signal	1400 kc.	1400 kc.	Ant. trimmer (C)

*It is recommended that a fiber aligning tool that snugly fits the slot in the powered iron core be used to prevent chipping of the slot.

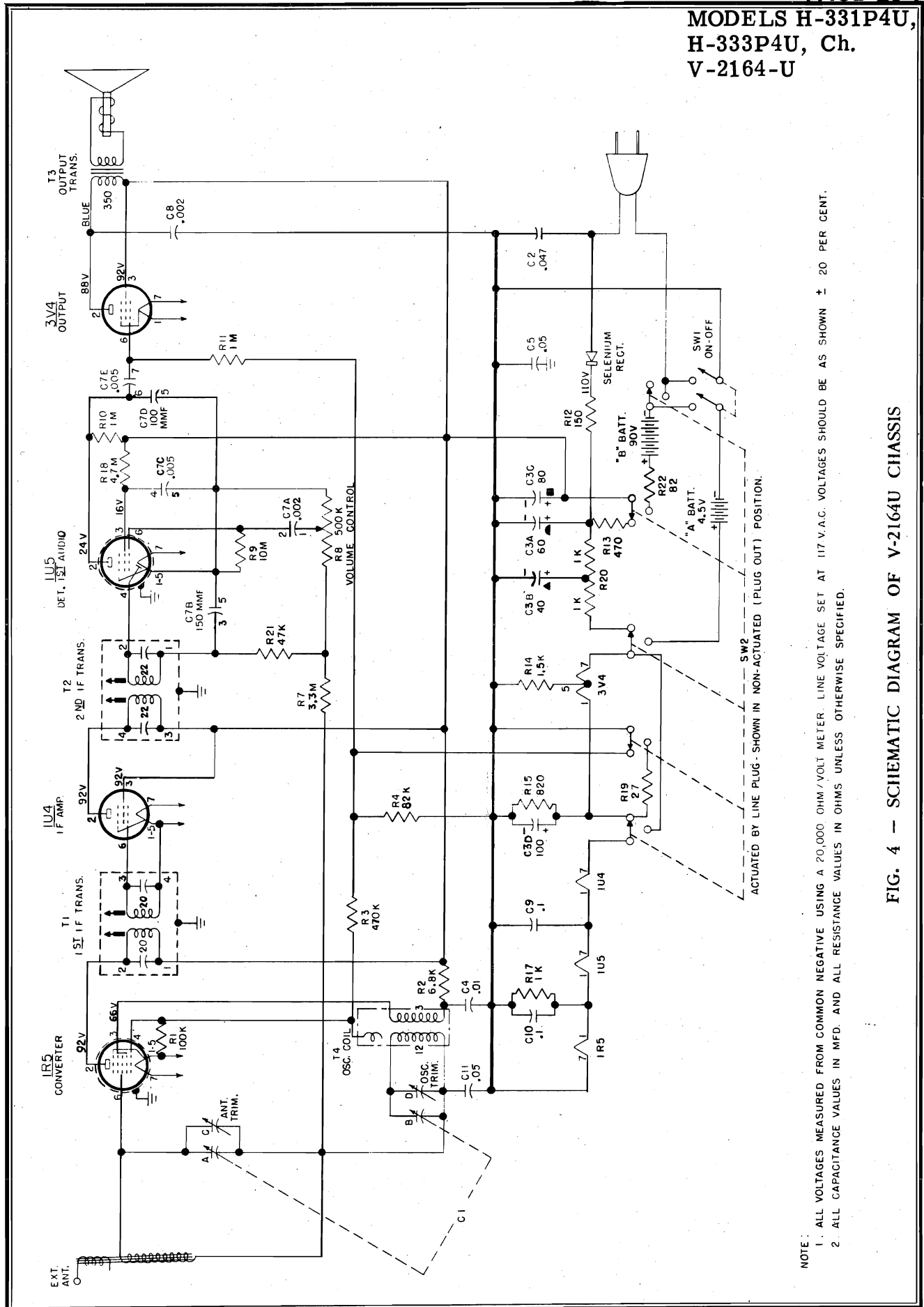

NOTE:
 1. ALL VOLTAGES MEASURED FROM COMMON NEGATIVE USING A 20,000 OHM/VOLT METER. LINE VOLTAGE SET AT 117 V.A.C. VOLTAGES SHOULD BE AS SHOWN \pm 20 PER CENT.
 2. ALL CAPACITANCE VALUES IN MFD. AND ALL RESISTANCE VALUES IN OHMS UNLESS OTHERWISE SPECIFIED.

FIG. 4 - SCHEMATIC DIAGRAM OF V-2164U CHASSIS

MODELS H-331P4U, H-333P4U, Ch. V-2164-U

PARTS LIST FOR MODELS H-331P4U AND H-333P4U

When ordering parts specify model number of set in addition to part number and description of part.

Ref. No.	Part No.	Description	Part No.	Description
C1	V-10417-1	Capacitor, variable (A, B, C, and D)		
C2	V-10157-4473M	Capacitor, .047 mfd 400 v.		
C3	V-6552-2	Capacitor, electrolytic (A, B, C and D)		
C4	V-9863-3	Capacitor, .01 mfd		
C5	RCP10W2503M	Capacitor, .05 mfd 200 v.	V-6120-5	Background, dial
C8	V-9863-2	Capacitor, .002 mfd	V-1234-2	Cabinet, H-331P4U (green)
C9	RCP10W2104M	Capacitor, .1 mfd 200 v.	V-1234-3	Cabinet, H-333P4U (brown)
C10	RCP10W2104M	Capacitor, .1 mfd 200 v.	V-10416-1	Cable assembly, battery
C11	RCP10W2503M	Capacitor, .05 mfd 200 v.	V-5426	Clip, IF mounting
	V-9446-2	Rectifier, selenium	V-4349-4	Cord, AC power
R1	RC20AE104M	Resistor, 100,000 ohms 1/2 w	V-3219S-1	Cord, dial (100' spool)
R2	RC20AE682M	Resistor, 6800 ohms 1/2 w	V-10853-1	Escutcheon, dial
R3	RC20AE474M	Resistor, 470,000 ohms 1/2 w	V-10438-1	Handle
R4	RC20AE823K	Resistor, 82,000 ohms 1/2 w	V-10420-1	Knob, H-331P4U
R7	RC20AE335M	Resistor, 3.3 megohms 1/2 w	V-10420-2	Knob, H-333P4U
R8	V-9993-3	Control, volume, 500,000 ohms (consists of R8 and SW1)	V-10921-1	Loop, antenna (iron core)
R9	RC20AE106M	Resistor, 10 megohms 1/2 w	V-10422-2	Pointer, dial
R10	RC20AE105M	Resistor, 1 megohms 1/2 w	V-4169-2	Shield, tube (1R5, 1U5)
R11	RC20AE105M	Resistor, 1 megohms 1/2 w	V-9888-3	Socket, miniature wafer (all tubes)
R12	V-6067-8	Resistor, 150 ohms 4 w	V-10401-1	Speaker, 4" PM (includes T3)
R13	RC20AE471K	Resistor, 470 ohms 1/2 w	V-5687	Spring, back cover hinge
R14	RC20AE152K	Resistor, 1500 ohms 1/2 w	V-6795-3	Spring, dial drive
R15	RC20AE821K	Resistor, 820 ohms 1/2 w		
R17	RC20AE102M	Resistor, 1000 ohms 1/2 w		
R18	RC20AE475M	Resistor, 4.7 megohm 1/2 w		
R19	RC20AE270K	Resistor, 27 ohms 1/2 w		
R20	V-10435-2	Resistor, ballast, 2000 ohms		
R21	RC20AE473M	Resistor, 47,000 ohms 1/2 w		
R22	RC20AE820K	Resistor, 82 ohms 1/2 w		
SW1	V-9993-3	Switch, on-off (consists of R8 and SW1)		
SW2	V-10426-1	Switch, line-battery		
T1	V-6972-5	Transformer, 1st IF		
T2	V-6972-6	Transformer, 2nd IF		
T3	V-10401-1	Transformer, audio output		
T4	V-5661-2	Transformer, oscillator		

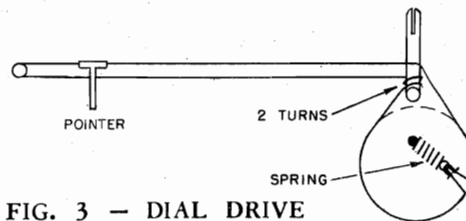

FIG. 3 - DIAL DRIVE

MODELS H-331P4U AND H-333P4U

The following changes are incorporated in later production of the V-2164U chassis:

1. To improve the operation of the HF oscillator at low line voltage, the dropping resistor for the pin #3 grid of the 1R5 tube (R2) is changed to 22,000 ohms, and the grid return resistor for the 1R5 and 3V4 tubes (R4) is changed to 150,000 ohms.

2. An improved line-battery switch (SW2) is used in later production. In chassis containing the improved switch which is designated V-10426-2, the 82 ohm resistor (R22) in series with the positive lead of the B battery is not used, and the battery is connected directly to the switch.

3. To prevent B battery leakage when the line plug is inserted for battery operation and the on-off switch is in off position, the connecting points for the negative lead from the A battery and the negative lead from the B battery are interchanged. The negative lead from the B battery now connects to the point where the A battery negative lead previously connected, and vice versa.

The parts list should be changed to read as follows:

R2	RC20AE223M	Resistor, 22,000 ohms 1/2 w	\$.05
R4	RC20AE154M	Resistor, 150,000 ohms 1/2 w	.04
SW2	V-10416-2	Switch, line-battery	1.15

**MODELS H-331P4,
H-332P4, H-333P4,
Ch. V-2164**

MODELS H-331P4U AND H-333P4U

The following changes are included in later production:

1. In some chassis, a 12 mmf capacitor (C12) is added in parallel with the antenna tuning section of the variable capacitor (C1) to assure that the antenna circuit can be aligned correctly.
2. C10, connected from common negative to the filaments of the 1R5 and 1U5, is removed from the chassis.

3. The suffix "U" is removed from the model number and the chassis number. This change does not indicate a change in either the model or the chassis; e.g., model H-331P4 is the same as model H-331P4U and chassis V-2164 is the same as chassis V-2164U.

The following items should be added to the parts list:

C7 V-9703-1	Capacitor, multiple (consists of A, B, C, and D)	\$.75
C12 R3CC20SL120K	Capacitor, 12 mmf19



MODEL H-332P4

(MAROON)

CHASSIS V-2164

SERVICE NOTES

For service information on Model H-332P4, refer to the H-331P4U and H-333P4U service notes and any supplementary information thereto. With the exception of coloring, Model H-332P4 is the same as Models H-331P4U and H-333P4U.

The cabinet and knob for Model H-332P4 are listed below. Other parts for this model are the same as those listed in the H-331P4U and H-333P4U service notes.

Part No.	Description	List Price Each
✚ V-1234-4	Cabinet, H-332P4 (maroon)	\$ 6.50*
✚ V-10420-3	Knob, H-332P4	.20

✚ New part number listed for the first time in Westinghouse radio or television service information.

* Price includes Federal Excise Tax.

NOTE: All prices are subject to change without notice.

MODELS H-414P4,
H-415P4, Ch. V-2182-2

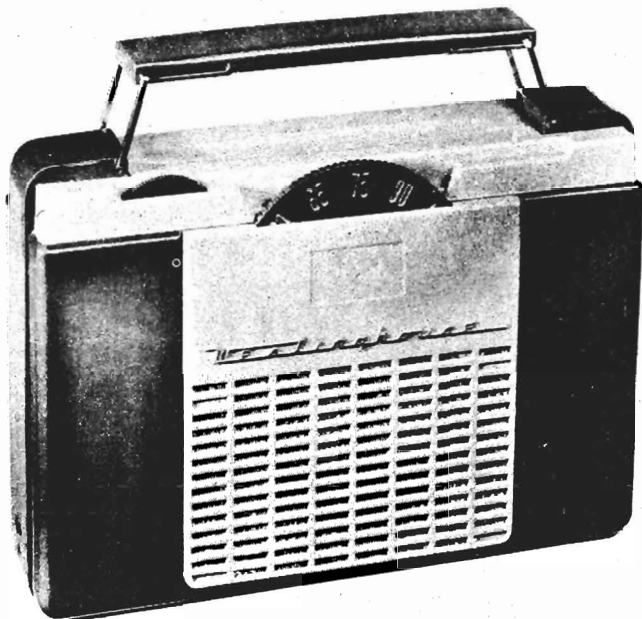

SERVICE NOTES

SPECIFICATIONS

FREQUENCY RANGE: 540 to 1600 kc.

INTERMEDIATE FREQUENCY: 455 kc.

TUBE COMPLEMENT:

- 1 1R5 Converter
- 1 1U4 IF Amplifier
- 1 1U5 Det., AVC and 1st AF Amp.
- 1 3V4 Power Output Amp.

BATTERIES:

- 1 "A" Battery (1.5 v.), Size D – Eveready 950, Burgess No. 2, or Ray-O-Vac No. 2.
- 1 "B" Battery (67.5 v.) – Eveready 467, Burgess XX45, or Ray-O-Vac 4367

CURRENT CONSUMPTION:

- "A" Battery 0.25 amp.
- "B" Battery..... .008 amp.

POWER OUTPUT:

- Undistorted075 watt.
- Maximum18 watt

LOUDSPEAKER: 2" x 3" PM

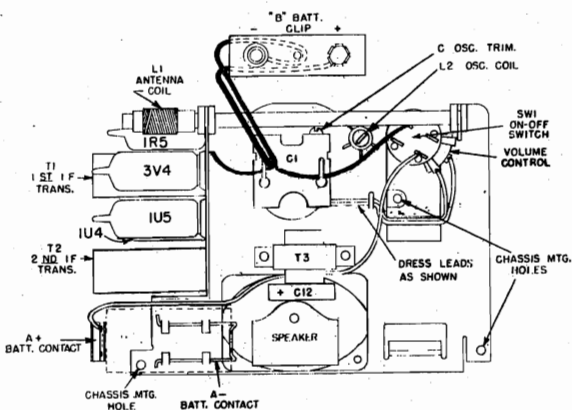

FIG. 2 – REAR VIEW OF
V-2182-2 CHASSIS



FIG 3 – TOOL REQUIRED
FOR IF ALIGNMENT

For service information on Model H-415P4, refer to the H-414P4 service notes and any supplementary information thereto. With the exception of the cabinet color, Model H-415P4 is the same as Model H-414P4.

ALIGNMENT

While making the following adjustments keep the volume control set for maximum output and the signal generator output attenuated to avoid AVC action.

Step	Connect Signal Generator to -	Signal Generator Frequency	Radio Dial	Adjust for Maximum Output -
1	Stator of RF section of tuning capacitor C1 through a .01 mfd capacitor.	455 kc.	Minimum capacity	Top and bottom slugs of 2nd and 1st IF transformers in order given. SEE NOTE.
2	Radiated signal	1400 kc.	1400 kc.	Osc. trimmer "C" (rock-in)
3	Radiated signal	600 kc.	600 kc.	Slug in osc. coil (L2) (rock-in)
4	Repeat steps 2 and 3			

NOTE: An aligning tool with a slender shaft and a hex head is required to align the IF transformers. A suitable tool is illustrated in Fig. 3. The bottom slugs as well as the top slugs are adjusted from the top of the transformers. To reach the bottom slugs, insert the slender shaft end of the aligning tool all the way through the top slug.

REMOVAL OF PARTS

TO REMOVE BACK COVER - Insert the edge of a coin into the slot in the bottom of the cabinet, and twist the coin.

TO REMOVE FIRST IF TRANSFORMER -

1. Lift antenna (L1) from its mounts and lay it to one side.
2. Remove the leads from under the clamps on the back of the tuning capacitor. NOTE: Be sure to dress the wires back in their original positions when parts are remounted -- see LEAD DRESS.
3. Dismount the tuning capacitor, C1, by removing its three mounting screws.
4. Disconnect the wires from the 1st IF transformer.
5. Unsolder and bend the transformer mounting lugs, and lift out the transformer.

TO REMOVE SECOND IF TRANSFORMER -

1. Disconnect the wires from the 2nd IF transformer.
2. Unsolder and bend the transformer mounting lugs, and lift out the transformer.

LEAD DRESS

To prevent feedback, the leads from the volume control must be dressed away from the audio output transformer and its plate lead. The plate lead must be dressed under the clip on the rear of the tuning capacitor. See Fig. 2.

The "B" battery leads should be dressed close to the chassis and should run under the clip on the rear of the tuning capacitor. This allows clearance for the back cover of the cabinet.

H-415P4 CABINET PARTS

MODELS H-414P4,
H-415P4, Ch. V-2182-2

Part No.	Description	List Price Each
✓ V-1267-5	Cabinet assy., includes back cover, handle, clips and grill cloth.	*
V-11167-2	Clip, handle	.06
✓ V-8709	Cover, back	*
✓ V-11111-5	Dial	.23
✓ V-11110-5	Handle, less clips	*
✓ V-11112-5	Knob, off-on-volume. Add to V-2182-2	*
	Chassis parts list.	.23
✓ V-5662-3	Cable, "B" Battery	*

PARTS LIST FOR MODEL H-414P4

Cabinet and Miscellaneous		List Price Each
✓ V-1267-4	Cabinet	**
V-11167-2	Clip, handle	.06
V-11127-1	Contact, A ✓ battery	.06
V-11136-1	Contact, A- battery	.06
V-11111-4	Dial	**
V-11110-4	Handle	**
V-11112-4	Knob	**
V-11142-1	Socket 7Pin miniature molded (1U5 and 3V4)	.17
V-11142-2	Socket 7Pin miniature molded (1R5 and 1U4)	.17
V-11135-1	Speaker, "2x3" oval P.M.	5.75*

V-2182-2 CHASSIS

C1 V-11126-1	Capacitor, variable (A, B, and C)	2.50
C2 V-5596	Capacitor, .005 mfd.	.25
C3 V-10710-4	Capacitor, 4 mmf.	.17
C4 V-9863-4	Capacitor, .0015 mfd.	.20
C5 RC10W2503M	Capacitor, .05 mfd 200V	.20
C7 V-10710-5	Capacitor, 100 mfd.	.17
C8 V-5596	Capacitor, .005 mfd.	.25
C9 V-10710-5	Capacitor, 100 mmf.	.17
C10 V-9863-2	Capacitor, .002 mfd.	.20
C11 V-9863-2	Capacitor, .002 mfd.	.20
C12 V-6321-2	Capacitor, 10 mfd. 90V	1.05
✓ L1 V-11132-2	Loop, antenna (iron core)	**
L2 V-11128-1	Coil, oscillator	.95
R1 RC20AE104K	Resistor, 100,000 ohm ½W	.05
R2 RC20AE153K	Resistor, 15,000 ohms ½W	.05
R3 RC20AE475M	Resistor, 4.7 megohms ½W	.05
R4 RC20AE335M	Resistor, 3.3 megohms ½W	.05
R5 RC20AE473M	Resistor, 47,000 ohms ½W	.05
R6 V-11129-1	Control, volume, 2 megohms (Consists of R6 and SW. 1)	1.20
R7 RC20AE475M	Resistor, 4.7 megohms ½W	.05
R9 RC20AE105M	Resistor, 1 megohms ½W	.05
R10 RC20AE335M	Resistor, 3.3 megohms	.05
R11 RC20AE391K	Resistor, 390 ohms ½W	.08
T1 V-11138-1	Transformer, 1st IF	1.65
T2 V-11138-2	Transformer, 2nd IF	1.65
T3 V-11139-1	Transformer, Audio output	2.00

✓ New Part listed for first time in Westinghouse Television or Radio service information.

* Includes Federal Excise Tax.

** Price Furnished on Request.

NOTE: All prices subject to change without notice.

MODELS H-409P4,
H-410P4, H-411P4,
Ch. V-2185-1

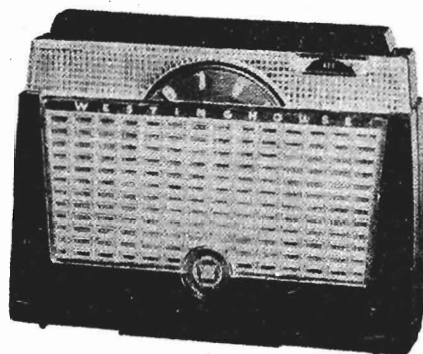

CHASSIS V-2185-1

MODEL H-377

AC POWER SUPPLY (OPTIONAL)

SERVICE NOTES

SPECIFICATIONS

FREQUENCY RANGE: 540 to 1600 kc.

INTERMEDIATE FREQUENCY: 455 kc.

TUBE COMPLEMENT:

- 1 1R5 Converter
- 1 1U4 IF Amplifier
- 1 1U5 Det., AVC and 1st AF Amp.
- 1 3V4 Power Output Amp.

POWER OUTPUT:

Battery Operation:

Undistorted075 watt
Maximum18 watt

Line Operation (with H-377 power supply):

Undistorted12 watt
Maximum22 watt

LOUDSPEAKER: 3½" x 3½" PM

BATTERIES:

"A" Battery (1.5 v.), Size G — Ray-O-Vac No. 8R, Burgess No. 21R, Eveready No. 964, or General No. 77.

NOTE: Smaller 1.5 v. (size D) batteries can be used as "A" batteries by rotating the A battery contact 180 degrees (see Fig. 2). Batteries recommended are Ray-O-Vac No. 2, Burgess No. 2R, or Eveready No. 950.

"B" Battery (67.5 v.) — Ray-O-Vac No. 946, Burgess No. P45, or Eveready No. 477.

LINE VOLTAGE (H-377 POWER SUPPLY):

..... 105 to 120 volts, 50 to 60 cycles AC

CURRENT CONSUMPTION:

"A" Battery 0.25 amp.
"B" Battery008 amp.

POWER CONSUMPTION (H-377 POWER SUPPLY):

..... 4 watts

MODELS H-409P4,
H-410P4, H-411P4,
Ch. V-2185-1

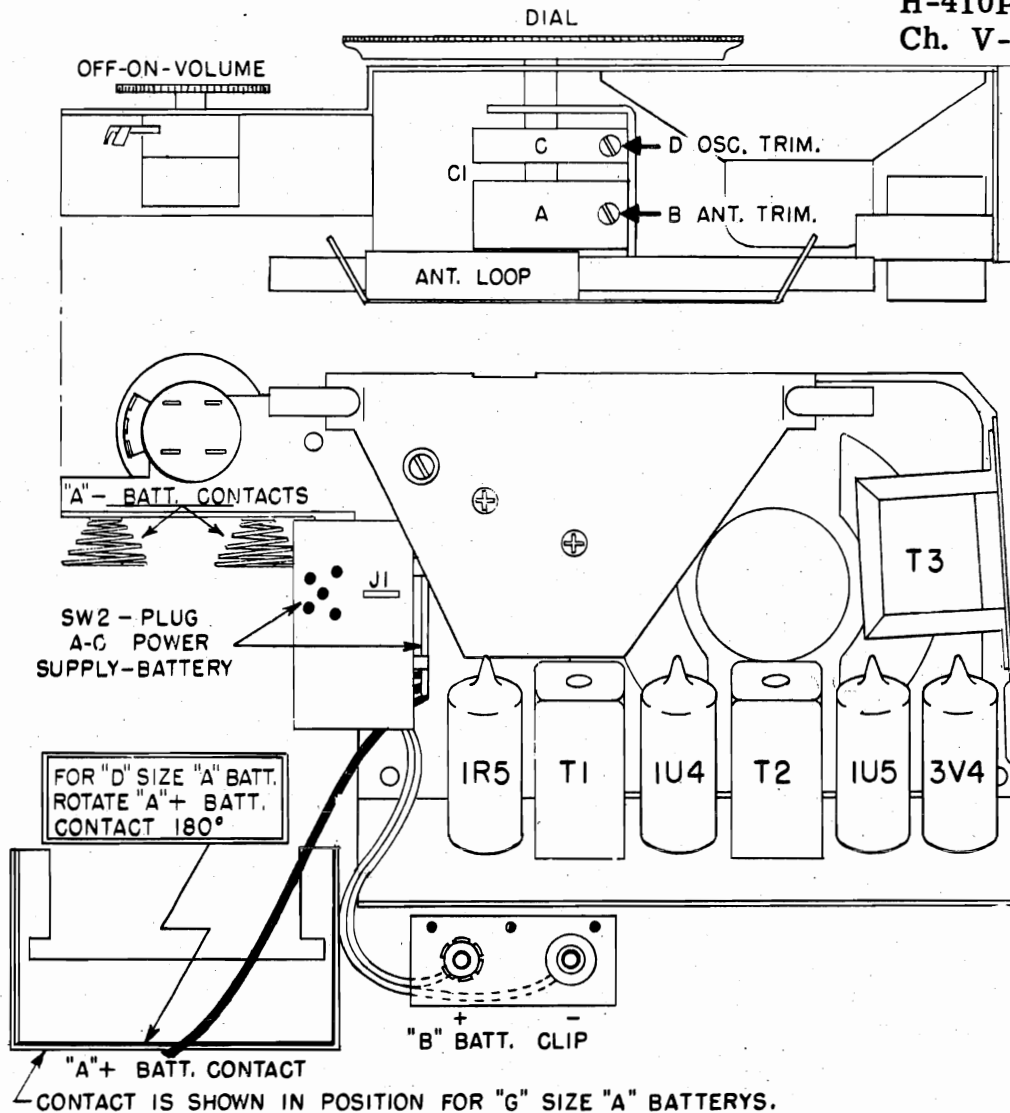

REAR VIEW OF V-2185-1 CHASSIS

ALIGNMENT

While making the following adjustments keep the volume control set for maximum output and the signal generator output attenuated to avoid AVC action.

Step	Connect Signal Generator to -	Signal Generator Frequency	Radio Dial	Adjust for Maximum Output -
1	Stator of RF section of tuning capacitor C1 through a .01 mfd capacitor	455 kc.	Minimum capacity	Top and bottom slugs of 2nd and 1st IF transformers in order given, SEE NOTE.
2	Radiated signal	1625 kc.	1625 kc.	Osc. trimmer "D" (rock-in)
3	Radiated signal	1400 kc.	1400 kc.	Ant. trimmer "B"
4	Repeat steps 2 and 3			

NOTE: When adjusting the IF transformers, it is recommended that a fiber aligning tool which snugly fits the slot in the powdered iron core be used to prevent chipping of the slot.

TO REMOVE BACK COVER - Insert the edge of a coin into the slot in the top of the cabinet, and twist the coin.

MODELS H-409P4,
H-410P4, H-411P4,
Ch. V-2185-1

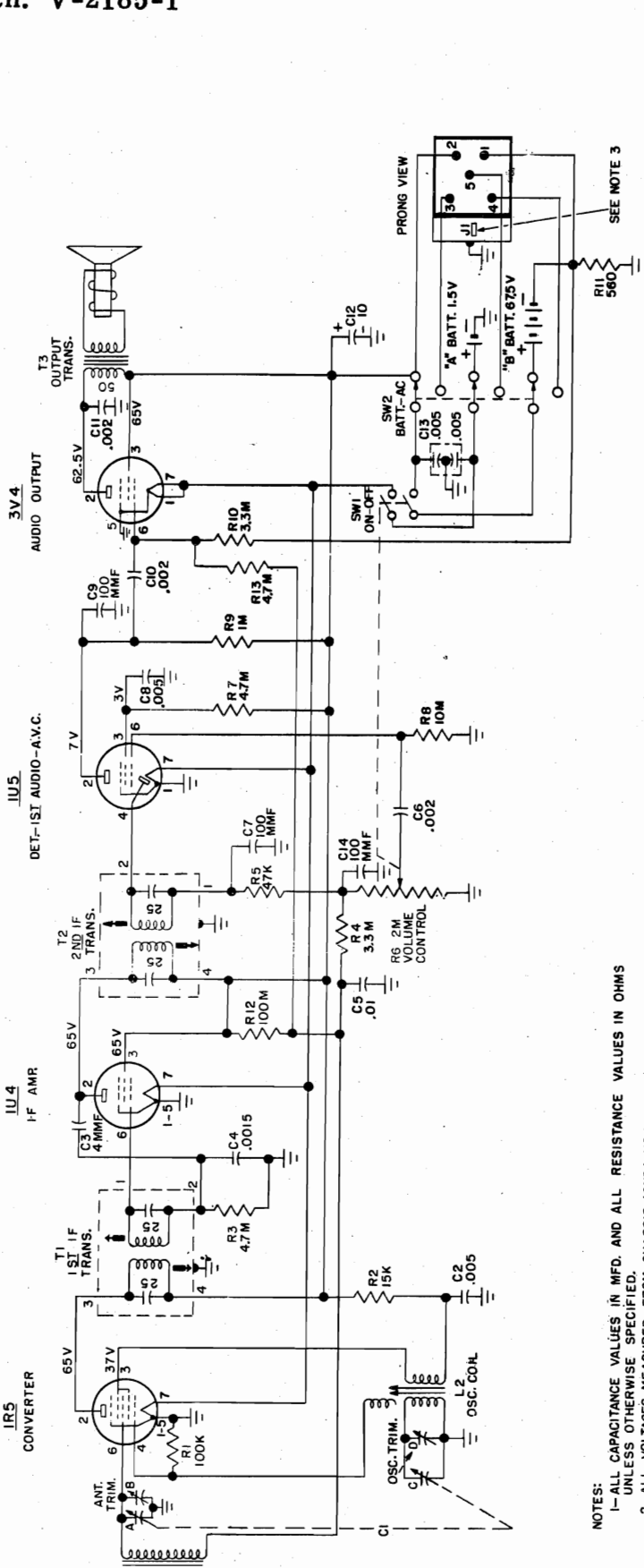

SCHEMATIC DIAGRAM

CHASSIS NO. V-2185

- NOTES:
- 1- ALL CAPACITANCE VALUES IN MFD. AND ALL RESISTANCE VALUES IN OHMS UNLESS OTHERWISE SPECIFIED.
 - 2- ALL VOLTAGES MEASURED FROM CHASSIS (GND.) USING A 20,000 OHM/VOLT METER. VOLTAGES SHOWN ARE BATTERY READINGS AND SHOULD BE ± 20 PER CENT. AUXILIARY POWER SUPPLY WILL INCREASE VOLTAGE READINGS APPROX. 20 PER CENT.
 - 3- SW2 ACTUATED BY BLADE (P51) ON FEMALE PLUG OF AUXILIARY POWER SUPPLY THROUGH J1.

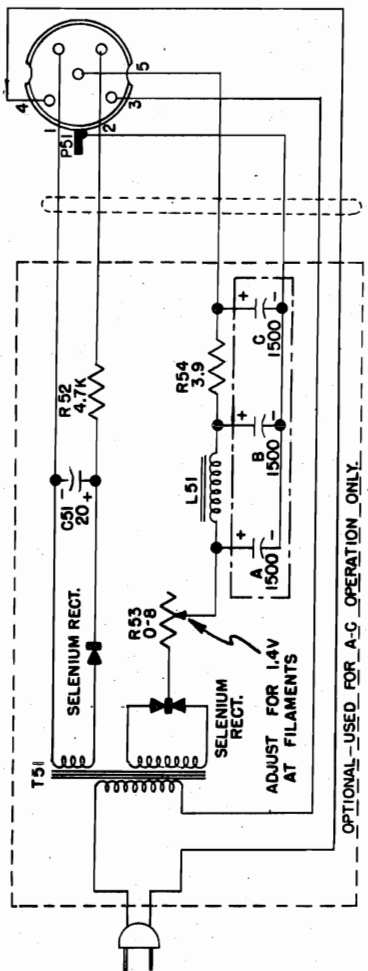

SCHEMATIC DIAGRAM

H-377

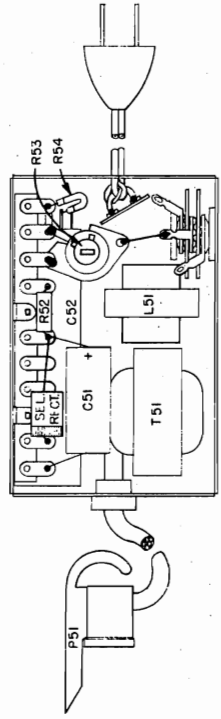

MODEL H-377 AC POWER SUPPLY

OPTIONAL - USED FOR A-C OPERATION ONLY

MODELS H-409P4,
H-410P4, H-411P4,
Ch. V-2185-1

PARTS LIST FOR MODELS H-409P4, H-410P4 AND H-411P4

When ordering parts, specify model number of set in addition to part number and description of part.

CABINET AND MISCELLANEOUS

Part No.	Description	List Price Each	Part No.	Description	List Price Each
+ V-11949-1	Cabinet assy. (H-409P4), includes back cover, handle, baffle and grille cloth	\$ **	+ V-8655	Cover assy., back (H-411P4)	\$ **
+ V-11949-2	Cabinet assy. (H-410P4), includes back cover, handle, baffle and grille cloth	**	+ V-11941-1	Dial	.90
+ V-11949-3	Cabinet assy. (H-411P4), includes back cover, handle, baffle and grille cloth	**	+ V-11938-1	Handle, (H-409P4)	**
+ V-11930	Cable assy., (B battery clip and leads)	**	+ V-11938-2	Handle, (H-410P4)	**
+ V-8653	Cover assy., back (H-409P4)	**	+ V-11938-3	Handle, (H-411P4)	**
+ V-8654	Cover assy., back (H-410P4)	**	+ V-11942-1	Knob, (H-409P4)	.20
			+ V-11942-2	Knob, (H-410P4)	.20
			+ V-11942-3	Knob, (H-411P4)	.20
			+ V-11142-2	Socket, miniature molded 7 pin (1U4)	.17
			V-11142-3	Socket, miniature molded 7 pin (1R5, 1U5, 3V4)	.17
			+ V-11924-1	Speaker, 3 1/2" PM	3.80*

V-2185-1 CHASSIS

Ref. No.	Part No.	Description	List Price Each	Ref. No.	Part No.	Description	List Price Each
+ C1	V-11919-1	Capacitor, variable (A,B,C,D)	\$ 2.50	R2	RC20AE153K	Resistor, 15,000 ohms 1/2 w.	.05
C2	R2CC62Z5Z502P	Capacitor, .005 mfd	.20	R3	RC20AE475M	Resistor, 4.7 megohms 1/2 w.	.05
C3	R1CC61S2L409F	Capacitor, 4 mmf	.20	R4	RC20AE335M	Resistor, 3.3 megohms 1/2 w.	.05
C4	R2CC61Z5Z152P	Capacitor, .0015 mfd	.20	R5	RC20AE473M	Resistor, 47,000 ohms 1/2 w.	.05
C5	R2CC63Z5Z103P	Capacitor, .01 mfd	.20	R6	V-11129-1	Control, volume 2 megohms	1.20
C6	R2CC61Z5Z202P	Capacitor, .002 mfd	.15	R7	RC20AE475M	Resistor, 4.7 megohms 1/2 w.	.05
C7	R1CC61S3N101M	Capacitor, 100 mmf	.20	R8	RC20AE106M	Resistor, 10 megohms 1/2 w.	.05
C8	R2CC62Z5Z502P	Capacitor, .005 mfd	.20	R9	RC20AE105M	Resistor, 1 megohm 1/2 w.	.05
C9	R1CC61S3N101M	Capacitor, 100 mmf	.20	R10	RC20AE335M	Resistor, 3.3 megohms 1/2 w.	.05
C10	R2CC61Z5Z202P	Capacitor, .002 mfd	.15	R11	RC20AE561K	Resistor, 560 ohms 1/2 w.	.04
C11	R2CC61Z5Z202P	Capacitor, .002 mfd	.15	R12	RC20AE107M	Resistor, 100 megohms 1/2 w.	.10
+ C12	V-6321-4	Capacitor, elec. 10 mfd, 90 volts	1.10	R13	RC20AE475M	Resistor, 4.7 megohms 1/2 w.	.05
C13	V-9044-1	Capacitor, dual, .005-.005 mfd	.39	SW1	V-11129-1	Switch, on-off (consists of R6 and SW1)	1.20
C14	R1CC61S3N101M	Capacitor, 100 mfd	.20	+ SW2	V-12211-1	Switch, assembly (AC power supply battery)	**
+ L1	V-11921-1	Loop, antenna (iron core)	1.95	+ T1	V-11925-1	Transformer, 1st IF	1.65
+ L2	V-11128-2	Coil, AM oscillator	.95	+ T2	V-11925-1	Transformer, 2nd IF	1.65
R1	RC20AE104M	Resistor, 100,000 ohms 1/2 w.	.05	+ T3	V-11926-1	Transformer, audio output	1.70

PARTS LIST FOR MODEL H-377 AC POWER SUPPLY

Ref. No.	Part No.	Description	List Price Each	Ref. No.	Part No.	Description	List Price Each
	V-5847-3	Bushing, strain relief (AC cord) (H-377)	\$.10	L51	V-11303-1	Reactor, filter	\$1.60
P51	V-11296-1	Cable assy., AC power supply (H-377)	2.85		V-11302-1	Rectifier, selenium 250 ma (A voltage)	1.85
	V-4349-1	Cord, AC power	.70		V-11189-1	Rectifier, selenium 12 ma (B voltage)	1.55
C51	V-6321-3	Capacitor, elec., 20 mfd 150 v.	1.25	R52	RC30AE472K	Resistor, 4700 ohms 1 w.	.09
C52	V-11184-1	Capacitor, elec., 1500 mfd 3 v., 1500 mfd 2 v., and 1500 mfd 1.5 v.	4.50	R53	V-11345-1	Resistor, adjustable	.40
				R54	V-6067-10	Resistor, 3,900 ohms 1 w.	.20
				T51	V-11304-1	Transformer, power	2.45

+ New part number listed for the first time in Westinghouse radio or television service information.

* Price includes Federal Excise Tax.

** Price furnished on request.

NOTE: All prices are subject to change without notice.

The 7H04Z1 chassis incorporates a superheterodyne circuit with two stages of IF, on the FM Band, and two stages on the AM Band, There is one stage of RF amplification on the FM Band.

When adjustments are made on the 7H04Z1 or any AC-DC chassis, a line isolation transformer (110-V input to 110-V output) is recommended in order to avoid a "hot" chassis. If an isolation transformer is not available, check the AC voltage between chassis and bench ground, and if there is any indication of voltage, reverse the plug before handling the set.

The IF transformers and the discriminator transformer are the new permeability tuned type. The advantage of an IF transformer of this type is its extreme stability under various humidity and temperature conditions. The upper coil is the secondary and the lower the primary. When adjusting these IF and discriminator transformers, tuning wrench 68-19 can be inserted into the top slug, rotated until maximum output is obtained and then dropped down to the lower slug and the same operation repeated. The tuning wrench is so designed that turning one slug does not affect the adjustment of the others.

FM IF Alignment: Reasonably accurate alignment can be made by following the procedure outlined in this service note.

FM Discriminator Alignment; When the secondary of the discriminator is aligned (operation 5) use sufficient signal input to get a good positive and negative indication before setting the slug for zero reading. A center zero indicating meter is recommended for this adjustment, but is not absolutely necessary. Reversing the leads of a non-zero center meter, or observing closely when the meter starts to go to the left (negative) of zero will give the same results.

Alignment of this chassis will, in most cases, be unnecessary unless an IF or RF transformer is replaced or the adjustments have been tampered with.

Correct alignment can only be made if the following procedure is followed:

A vacuum tube voltmeter with isolation resistor of 2,000,000 ohms in series with the hot lead will serve for FM adjustments. This lead should be shielded.

An AC output meter connected across the primary or secondary of the output transformer will be satisfactory for all AM adjustments.

The signal generator output should be kept just high enough to get an indication on the meter.

- (a) Vacuum Tube Voltmeter Lug 7 on discriminator transformer to chassis (half discriminator load).
- (b) Vacuum Tube Voltmeter Lug 5 on discriminator transformer to chassis (full discriminator load).
- (c) Vacuum Tube Voltmeter from Limiter Grid to Chassis.
- (d) Loosen Slugs by applying a hot iron to the cement.

MODEL H723Z1,
Ch. 7H04Z1

NO.	DIAG. NO.	DESCRIPTION	PRICE
46-859		Dial Assembly	.15
46-860		Band Switch Knob	.15
46-900		Tuning Control Knob	.10
59-251		Volume Control Knob	.70
80-69		Dial Pointer	.05
80-444		Dial Cord Tension Spring	.05
80-580		Tuner Arm Tension Spring	.06
188-150		Tuner Arm Stop Spring	.55
S-14524		Retaining Ring (1 used on S-17334 & S-17467)	.75
S-14525		Capacitor Pulley & Cam Assembly	.45
S-17334		Tuner Arm Assembly	.15
S-17336		Tuning Shaft & Pulley Assembly	.60
S-17467		Tuning Shaft Brkt. & Ins. Strip Assembly	
S-18442		Brkt. & Pulley Assembly	
		Dial Cord & Eyelet Assembly	
		Coils & Chokes	
		F.M. Antenna Coil	
20-355	L1	3rd. I.F. Trans. - 455 Kc.	1.60
95-1102	T3A	1st. & 3rd. I.F. Trans. - 10.7 Mc (2 used)	2.25
95-1150	T1,T3	Disc. Trans. - 10.7 Mc	2.25
95-1153	T4	1st. I.F. Trans. - 455 Kc	1.60
95-1250	T1A	2nd. I.F. Trans. - 10.7 Mc & 455 Kc	1.65
95-1251	T2	F.M. Detector Coil Assembly	.75
S-13871	L2	Broadcast Osc. Coil Assembly	.65
S-15694	L3	F.M. Osc. Coil Assembly	.55
S-15733	L4		
		Condensers	
22-3	C6	.01 Mfd. Ceramic (8 used)	.26
22-5	C7	1.10 Mmfd. Ceramic (Disc.)	.26
22-6	C22	470 Mmfd. Ceramic	.26
22-229	C21	.005 Mfd.	.20
22-448	C13	.004 Mfd.	.20
22-829	C11	.05 Mfd.	.20
22-830	C15	.02 Mfd.	.20
22-1126	C23	.01 Mfd.	.20
22-1158	C16	.05 Mfd.	.20
22-1220	C14	.002 Mfd.	.20
22-1367	C9	50 Mmfd. Ceramic	.33
22-1506	C8	22 Mmfd. Ceramic	.33
22-1676	C20	.001 Mfd. Ceramic (3 used)	.40
22-1742	C1	Two Section Gang Cond.	3.00
22-1757	C17, 18	Elect. Cond. 40 Mfd. - 1.50V x 80 Mfd. 150V	2.50
22-1766	C10	.68 Mmfd. Ceramic	.20
22-1775	C24	.047 Mfd.	.26
22-1852	C5	7.5 Mmfd. Ceramic	.35
22-1887	G19	25 Mmfd. Ceramic	.26
22-2112	C27	.001 Mfd. Ceramic	.30
22-2276	C26	Dual Ceramic .01 Mfd. -.01 Mfd. 500V	.50
		Resistors	
63-686	R18	150 ohm W.W. 1/2W 10% Ins. Res.	.21
63-1450	R13	22 ohm W.W. 1W 20% Ins. Res.	.24
63-1744	R2	100 ohm 1/2W 20% Ins. Res.	.21 (2 used)
63-1758	R5	220 ohm 1/2W 20% Ins. Res.	.21 (6 used)
63-1782	R11	820 ohm 1/2W 10% Ins. Res.	.21
63-1800	R14	2200 ohm 1/2W 20% Ins. Res.	.21 (2 used)

Prices shown are suggested list prices and are subject to change.

PART NO. DIAG. NO. DESCRIPTION PRICE

63-1828	R4	10K ohm	Res.	.21
63-1835	R15	1/2W 20% Ins.	Res.	.21
63-1856	R19	1/2W 20% Ins.	Res.	.21 (2 used)
63-1870	R8	1/2W 20% Ins.	Res.	.21 (3 used)
63-1876	R16	1/2W 20% Ins.	Res.	.21 (2 used)
63-1898	R17	1/2W 20% Ins.	Res.	.21 (2 used)
63-1912	R9	1/2W 20% Ins.	Res.	.21
63-1926	R7	2.2 Megohm	Res.	.21 (2 used)
63-1940	R3	4.7 Megohm	Res.	.21 (3 used)
63-2143	R10	Volume Control & Switch	Res.	1.81
63-2424	R21	39 ohm W.W. 1W 10% Ins.	Res.	.30
63-3137	R12	1000" W.W. 5W 20% Ins.	Res.	
		Miscellaneous		
11-85		Line Cord & Plug (6 ft.)		.65
12-1070		Wavemagnet Mtg. Brkt.		.25
14-1350		Plastic Cabinet for H723Z1		
16-656		Packing Carton		6.00
49-707	SP1	5 1/4" PM Speaker		
		Cone & Voice Coil		
		Output Trans.		
54-129		Speed Nut (9 used on Baffle & Grille Cloth)		.01
57-1717		Chassis Bottom Plate		.30
57-1721		Emblem Plate		.25
58-200		Two Prong Plug		.15
78-806		Miniature Tube Socket		.35
78-850		Miniature Tube Socket		.20
78-869		Miniature Tube Socket		.15
78-870		Miniature Tube Socket (3 used)		.15
78-871		Miniature Tube Socket		.15
80-884		Ground Spring		.03
83-1056		Wavemagnet Mtg. Strip		.07
85-516		Insulator Strip		.01
85-516	S1	Band Switch		.03
93-94		Insulating Shoulder Washer		.18
93-1097		Insulating Washer		.02
94-485		Insulating Bushing		.01
97-293		Chassis Mtg. Stud		.02
110-180		Grill Cloth		.40
112-281		#10 x 3/4" Truss Hd. ST St. Br. (2 used)		.40
		Chassis Mtg.		.10
114-297		#6 x 1/4" Hex Hd. ST (1 used on S-17467 & 6 used 57-717)		.01
114-356		#6 x 1/4" Hex Hd. ST (used on 212-7)		.02
126-618		Tube Shield		.02
139-98		Speaker Baffle		.40
149-64		Iron Core & Spring (2 used)		.40
159-69		Plug Button (4 used on S-17366)		.40
196-153		Speaker Gasket		.10
202-697		F.M. Instruction Book		1.80
202-698		Instruction Book		1.25
212-7	SE1	Selenium Rectifier		1.50
S-14957	L5	Wavemagnet Assembly		
S-17366		Cabinet Back Assembly (complete)		
S-18434		Band Switch Ext. Shaft Assembly		

The 7H04Z2 chassis incorporates a superheterodyne circuit with two stages of IF, on the FM Band, and two stages on the AM Band. There is one stage of RF amplification on the FM Band.

When adjustments are made on the 7H04Z2 or any AC-DC chassis, a line isolation transformer (110-V input to 110-V output) is recommended in order to avoid a "hot" chassis. If an isolation transformer is not available, check the AC voltage between chassis and bench ground, and if there is any indication of voltage, reverse the plug before handling the set.

The IF transformers and the discriminator transformer are the new permeability tuned type. The advantage of an IF transformer of this type is its extreme stability under various humidity and temperature conditions. The upper coil is the secondary and the lower the primary. When adjusting these IF and discriminator transformers, tuning wrench 68-19 can be inserted into the top slug, rotated until maximum output is obtained and then dropped down to the lower slug and the same operation repeated. The tuning wrench is so designed that turning one slug does not affect the adjustment of the others.

FM IF Alignment: Because of the wide band pass, it is desirable to use a FM signal generator and a cathode ray oscilloscope when aligning the FM IF channel. The instruction book for the Zenith Model 800 Signal Generator (Form Z8001) covers complete FM alignment procedure. If visual alignment equipment is unavailable, reasonably accurate alignment can be made by following the procedure outlined in this service note.

FM Discriminator Alignment: When the secondary of the discriminator is aligned (operation 5) use sufficient signal input to get a good positive and negative indication before setting the slug for

zero reading. A center zero indicating meter is recommended for this adjustment, but is not absolutely necessary. Reversing the leads of a non-zero center meter, or observing closely when the meter starts to go to the left (negative) of zero will give the same results.

Alignment of this chassis will, in most cases, be unnecessary unless an IF or RF transformer is replaced or the adjustments have been tampered with.

Correct alignment can only be made if the following procedure is followed:

A vacuum tube voltmeter with isolation resistor of 2,000,000 ohms in series with the hot lead will serve for FM adjustments. This lead should be shielded.

An AC output meter connected across the primary or secondary of the output transformer will be satisfactory for all AM adjustments.

The signal generator output should be kept just high enough to get an indication on the meter.

(a) Vacuum Tube Voltmeter Lug 7 on discriminator transformer to chassis (half discriminator load).

(b) Vacuum Tube Voltmeter Lug 5 on discriminator transformer to chassis (full discriminator load).

(c) Vacuum Tube Voltmeter from Limiter Grid to Chassis.

(d) Loosen Slugs by applying a hot iron to the cement.

MODEL H723Z2,
Ch. 7H04Z2

TUBE AND TRIMMER LOCATION

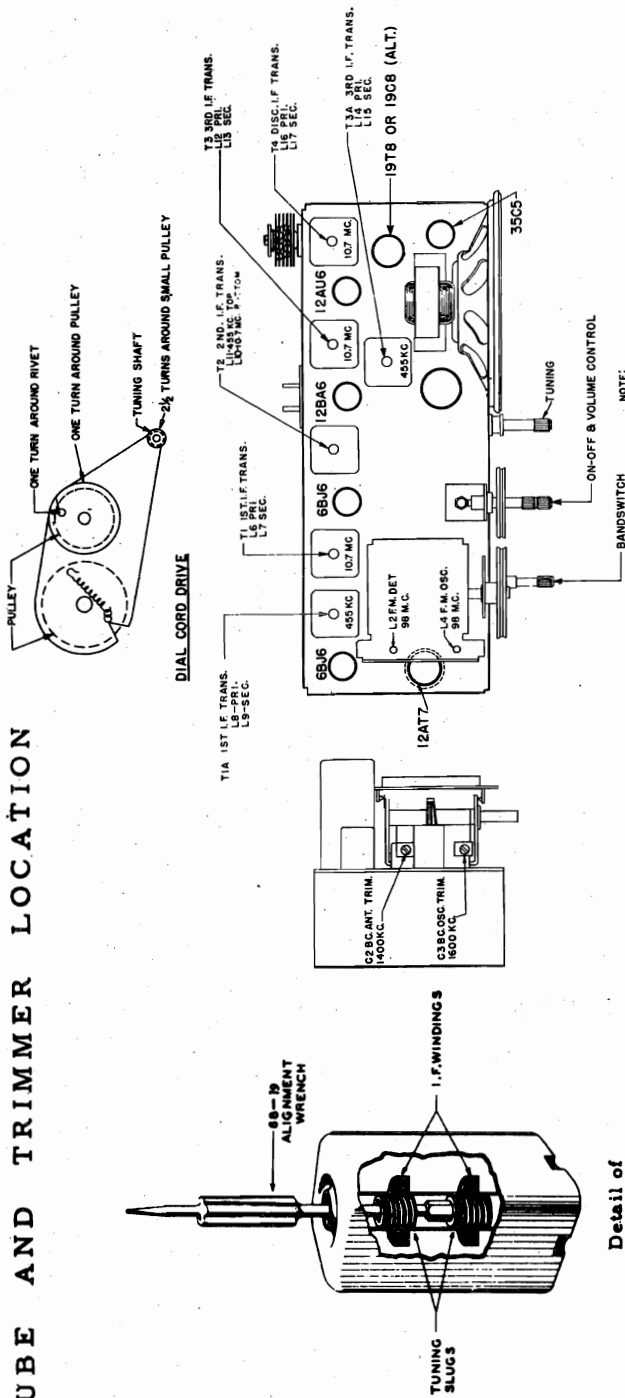

NOTE:
IF TRANSFORMER CORE ADJUSTMENTS ARE
PRIMARY ADJ. BOTTOM
SECONDARY ADJ. TOP

ALIGNMENT PROCEDURE

Operation	Connect Oscillator to	Dummy Antenna	Input Signal Frequency	Band	Set Dial To	Adj. Trimmers	Purpose
1	Pin 2-12AT7 Converter	.05 Mfd.	455 Kc. Modulated	BC	600 Kc.	L8, 9, 11, 14, 15	Align I. F. channel for maximum output.
2	2 turns loosely cpid. to wavemagnet		1600 Kc. Modulated	BC	1600 Kc.	C3	Set oscillator to dial scale.
3	2 turns loosely cpid. to wavemagnet		1400 Kc. Modulated	BC	1400 Kc.	C2	Align antenna stage.
4 (a)	Pin 1 (grid) on 12AU6 limiter.	.05 Mfd.	10.7 Mc. Unmodulated	FM		L16 coil slug Primary discr.	Align primary of discriminator for maximum reading.
5 (b)	Pin 1 (grid) on 12AU6 limiter.	.05 Mfd.	10.7 Mc. Unmodulated	FM		L17 coil slug sec. of discr.	Adjust secondary of discriminator for zero reading.
6 (c)	Pin 1 (grid) on 12BA6 2nd IF.	.05 Mfd.	10.7 Mc. Unmodulated	FM		L12 and 13 Prim. and Sec. of 3rd IF trans.	Align 3rd IF transformer for maximum reading.
7 (c)	Pin 1 (grid) on 6B76 1st IF.	.05 Mfd.	10.7 Mc. Unmodulated	FM		L10 Prim. of 2nd IF transformer.	Align 2nd IF transformer for maximum reading.
8 (c)	Pin 2 (grid) on 12AT7 converter tube socket	.05 Mfd.	10.7 Mc. Unmodulated	FM		L6 and L7 Prim. and Sec. of 1st IF transformer.	Align 1st IF transformer for maximum reading.
9 (c)	Antenna Post FM (Re-move line ant.)	270 ohms	98 Mc. Unmodulated	FM	98 Mc.	L4 Osc. Coil	Set Oscillator to dial scale.
10 (c) (d)		270 ohms	98 Mc. Unmodulated	FM	98 Mc.	L2 Det. Coil.	Align det. stage to maximum reading.

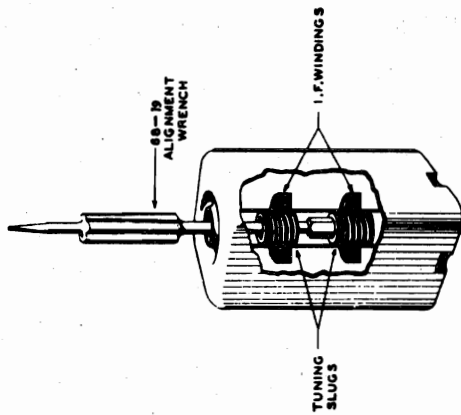

Detail of IF Transformer

MODEL H723Z2,
Ch. 7H04Z2

PARTS LIST

PART NO.	DIAG. NO.	DESCRIPTION	PRICE
H723Z2 (Chassis 7H04Z2)			
46-859		Dial Assembly	
46-860		Band Switch Knob	.15
46-900		Tuning Control Knob	.15
59-251		Volume Control Knob	.10
80-469		Dial Pointer	.70
80-444		Dial Cord Tension Spring	.05
80-817		Tuner Arm Stop Spring	.06
80-818		Tuner Spring	.12
188-150		Tuner Arm Pressure Spring	.02
S-14524		Retaining Ring (1 used on S-17334 & S-17467)	.55
S-14525		Capacitor, Pulley & Cam Assembly	.75
S-17334		Tuner Arm Assembly	.15
S-17467		Tuning Shaft Brkt. & Ins. Strip Assembly	.60
S-18442		Brkt. & Pulley Assembly	.10
		Dial Cord & Eyelet Assembly	
Coils & Chokes			
20-355 L1		F.M. Antenna Coil	.15
95-1102 T3A		3rd. I.F. Transformer - 455 Kc	1.60
95-1150 T1,T3		1st. & 3rd. I.F. Transformer - 10.7 Mc (2 used)	2.25
95-1153 T4		Discriminator Transformer - 10.7 Mc	2.25
95-1250 T1A		1st. I.F. Transformer - 455 Kc	1.60
95-1251 T2		2nd. I.F. Transformer - 10.7 Mc & 455 Kc	1.65
S-13871 L2		FM Detector Coil Assembly	.75
S-15694 L3		Broadcast Osc. Coil Assembly	.65
S-15733 L4		FM Oscillator Coil Assembly	.55
Condensers			
22-3 C6		.01 Mfd. Ceramic (8 used)	.26
22-5 C7		110 Mmfd. Ceramic (2 used) (Disc)	.26
22-6 C22		470 Mmfd. Ceramic	.20
22-229 C21		.005 Mfd.	.20
22-448 C13		.004 Mfd.	.20
22-829 C11		.05 Mfd.	.20
22-830 C15		.02 Mfd.	.20
22-1126 C23		.01 Mfd.	.20
22-1158 C16		.05 Mfd.	.20
22-1320 C14		.002 Mfd.	.35
22-1367 C9		50 Mmfd. Ceramic	.35
22-1506 C8		22 Mmfd. Ceramic (3 used)	.40
22-1742 C1		Two Section Gang Condenser	3.00
22-1757 C17,C18		Elect. 40 Mfd.-150Vx80Mfd.-150V	2.50
22-1766 C10		.69 Mmfd. Ceramic	.20
22-1775 C24		.047 Mmfd.	.26
22-1852 C5		7.5 Mmfd. Ceramic	.35
22-1887 C19		25 Mmfd. Ceramic	.20
22-2112 C27		.001 Mfd.	.30
22-2276 C26		Dual Ceramic .01 Mfd.-.01 Mfd.	.50
Resistors			
63-686 R18		150 ohm WW 1/4W 10% Ins.	.21
63-1450 R13		22 ohm WW 1/4W 20% Ins.	.21
63-1744 R2		100 ohm WW 20% Ins.	.21
63-1758 R5		220 ohm WW 20% Ins.	.21
63-1782 R11		820 ohm WW 10% Ins.	.21
Resistors (Continued)			
2200 ohm		1/4W 20% Ins.	.21
10K ohm		1/4W 20% Ins.	.21
63-1835 R15		15K ohm	.21
63-1856 R19		1/4W 20% Ins.	.21
63-1870 R8		1/4W 20% Ins.	.21
63-1876 R16		100K ohm	.21
63-1898 R17		150K ohm	.21
63-1912 R9		470K ohm	.21
63-1926 R7		1 Megohm	.21
63-1940 R3		1/4W 20% Ins.	.21
63-2143 R10		4.7 Megohm	.21
63-2797 R21		Volume Control & Switch	1.81
63-3137 R12		Special Resistor	.85
1K ohm WW 5W 20% Ins.		Res.	.70
Miscellaneous			
11-85		Line Cord & Plug (6 ft. lg.)	.65
12-1070		Wavemagnet Mg. Brkt.	.25
14-1350		Plastic Cabinet for H723Z2	6.25
16-656		Packing Carton	6.00
49-707 SP1		5 1/4" PM Speaker	1.73
208-707 Cone & Voice Coil		208-707 Output Transformer	1.67
54-129		Speed Nut (9 used on Baffle & Grille Cloth	.01
54-271		6-32x1/4" Palmut Steel (6 used on IF's)	.30
57-1717		Chassis Bottom Plate	.25
57-1721		Emblem Plate	.10
58-200		Two Prong Plug	.15
78-806		Miniature Tube Socket	.35
78-850		Miniature Tube Socket	.20
78-869		Miniature Tube Socket	.15
78-870		Miniature Tube Socket (3 used)	.03
78-871		Ground Spring	.03
80-884		Wavemagnet Mg. Strip	.03
83-1056		Rectifier Ins. Strip	.03
83-1520		L.F. Trans. Support Strip (6 used)	.07
83-1640		Insulator Strip	1.50
85-516 S1		Band Switch	.01
93-94		Insulating Shoulder Washer	.01
93-1097		Insulating Washer	.03
94-485		Insulating Bushing	.18
97-293		Chassis Mg. Stud (2 used)	.75
110-180		Grille Cloth	.02
112-281		#10x3/4" Truss Hd. S.T. St. Br. (2 used	.01
114-297		Chassis Mg.)	.02
114-356		#6x1/4" Hex Hd. S.T. (1 used on S-17467 & 6 used on S-1717)	.02
114-394		#6x1-1/4" Hex Hd. S.T. (used only on 212-7)	.02
126-618		6-32x1/2" Hex Hd. S.T. (used only on 212-13)	.02
139-98		Tube Shield	.20
149-64		Speaker Baffle	.40
159-69		Iron Core & Spring (2 used)	.01
196-153		Plug Button (4 used on S-17366)	.40
202-697		Speaker Gasket	.10
202-915		F.M. Instruction Book	.10
212-7 SE1		Instruction Book	1.80
S-14957 L5		Selenium Rectifier (or 212-13)	1.25
S-17366		Wavemagnet Assembly	1.50
S-18434		Cabinet Back Assembly (Complete)	.65
		Band Switch Ext. Shaft Assembly	

Prices shown are suggested list prices, and are subject to change without notice.

MODEL H724Z1,
Ch. 7H02Z1

The 7H02Z1 chassis incorporates a superheterodyne circuit with two stages of IF, on the FM Band, and two stages on the AM Band. There is one stage of RF amplification on the FM Band.

When adjustments are made on the 7H02Z1 or any AC-DC chassis, a line isolation transformer (110-V input to 110-V output) is recommended in order to avoid a "hot" chassis. If an isolation transformer is not available, check the AC voltage between chassis and bench ground, and if there is any indication of voltage, reverse the plug before handling the set.

The I.F. transformers and the discriminator transformer are the new permeability tuned type. The advantage of an IF transformer of this type is its extreme stability under various humidity and temperature conditions. The upper coil is the secondary and the lower the primary. When adjusting these IF and discriminator transformers, tuning wrench 68-19 can be inserted into the top slug, rotated until maximum output is obtained and then dropped down to the lower slug and the same operation repeated. The tuning wrench is so designed that turning one slug does not affect the adjustment of the other.

FM IF Alignment: Reasonably accurate alignment can be made by following the procedure outlined in this service note.

FM Discriminator Alignment: When the secondary of the discriminator is aligned (operation 5) use sufficient signal input to get a good positive and negative indication before setting the slug for zero reading. A center zero indicating meter is recommended for this adjustment, but is not absolutely necessary. Reversing the leads of a non-zero center meter, or observing closely when the meter starts to go to the left (negative) of zero will give the same results.

Alignment of this chassis will, in most cases, be unnecessary unless an IF or RF transformer is replaced or the adjustments have been tampered with.

Correct alignment can only be made if the following procedure is followed:

A vacuum tube voltmeter with an isolation resistor of 2,000,000 ohms in series with the hot lead will serve for FM adjustments. This lead should be shielded.

An AC output meter connected across the primary or secondary of the output transformer will be satisfactory for all AM adjustments.

The signal generator output should be kept just high enough to get an indication on the meter.

- (a) Vacuum Tube Voltmeter Lug 7 on discriminator transformer to chassis (half discriminator load).
- (b) Vacuum Tube Voltmeter Lug 5 on discriminator transformer to chassis (full discriminator load).
- (c) Vacuum Tube Voltmeter from Limiter Grid to Chassis.
- (d) Loosen Slugs by applying a hot iron to the cement.

MODEL H724Z1,
Ch. 7H02Z1

TUBE AND TRIMMER LOCATION

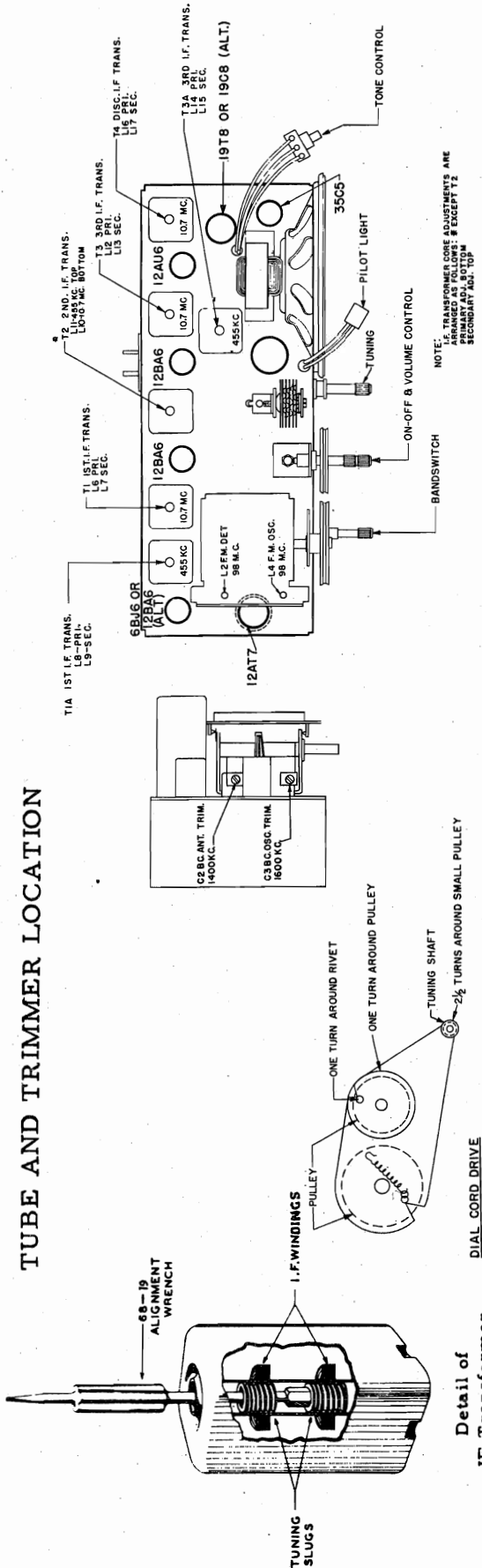

ALIGNMENT PROCEDURE

Operation	Connect Oscillator to	Dummy Antenna	Input Signal Frequency	Band	Set Dial To	Adj. Trimmers	Purpose
1	Pin 2 12A7 Converter. 2 turns loosely cpl'd. to wavemagnet	.05 Mfd.	455 Kc. Modulated	BC	600 Kc.	L8, 9, 11, 14, 15	Align I. F. channel for maximum output.
2	2 turns loosely cpl'd. to wavemagnet		1600 Kc. Modulated	BC	1600 Kc.	C3	Set oscillator to dial scale.
3	2 turns loosely cpl'd. to wavemagnet		1400 Kc. Modulated	BC	1400 Kc.	C2	Align antenna stage.
4 (a)	Pin 1 (grid) on 12AU6 limiter.	.05 Mfd.	10.7 Mc. Unmodulated	FM 100		L16 coil slug Primary discr.	Align primary of discriminator for maximum reading.
5 (b)	Pin 1 (grid) on 12AU6 limiter	.05 Mfd.	10.7 Mc. Unmodulated	FM 100		L17 coil slug sec. of discr.	Adjust secondary of discriminator for zero reading.
6 (c)	Pin 1 (grid) on 12BA6 2nd IF.	.05 Mfd.	10.7 Mc. Unmodulated	FM 100		L12 and L13 Prim. and Sec. of 3rd IF trans.	Align 3rd IF transformer for maximum reading.
7 (c)	Pin 1 (grid) on 12BA6 1st IF.	.05 Mfd.	10.7 Mc. Unmodulated	FM 100		L10 Prim. of 2nd IF transformer	Align 2nd IF transformer for maximum reading.
8 (c)	Pin 2 (grid) on 12A7 converter tube socket.	.05 Mfd.	10.7 Mc. Unmodulated	FM 100		L6 and L7 Prim. and Sec. of 1st IF transformer	Align 1st IF transformer for maximum reading.
9 (c)	Antenna Post FM (Re-move line ant.)	270 ohms	98 Mc. Unmodulated.	FM 100	98 Mc.	L4 Osc. Coil Slug	Set Oscillator to dial scale.
10 (c) (d)		270 ohms	98 Mc. Unmodulated	FM 100	98 Mc.	L2 Det. Coil Slug	Align det. stage to maximum reading

MODEL H724Z1,
Ch. 7H02Z1

PARTS LIST

PART NO.	DIAG. NO.	DESCRIPTION	PRICE
<u>DIAL ASSEMBLY</u>			
26-463		Dial Scale	
46-859		Bandswitch Knob	.15
46-860		Tuning Control Knob	.15
46-900		Vol. Control Knob	.15
46-901		Tone Control Knob	.10
59-251		Dial Pointer	.70
78-932		Dial Light Socket Assem.	
80-69		Dial Cord Tension Spring	.05
80-444		Tuner Arm Tension Spring	.05
80-580		Tuner Arm Stop Spring	.06
100-105	PL1	Neon Indicator Bulb	.11
171-11		Pilot Light Jewel	.20
188-150		Retaining Ring (1 used on S-17334 & 1 used with S-17467)	
S-14524		Cond. Pulley & Cam Assem.	.55
S-14525		Tuner Arm Assem.	.75
S-17334		Tuning Shaft & Pulley Assem.	.45
S-17336		Tuning Shaft Brkt & Ins. Strip Assem.	.15
S-17467		Brkt. & Pulley Assem.	.60
S-18442		Dial Cord & Eyelet Assem.	
<u>COILS & CHOKES</u>			
20-355	L1	F.M. Ant. Coil	
95-1102	T3A	3rd I.F. Trans. - 455 kc	1.60
95-1150	T1,T3	1st & 3rd I.F. Trans. - 10.7 Mc. (2 used)	2.25
95-1153	T4	Disc. Trans. - 10.77 Mc.	2.25
95-1250	T1A	1st I.F. Trans. - 455 kc	1.60
95-1251	T2	2nd I.F. Trans. - 10.7 Mc & 455 kc	1.65
S-13871	L2	F.M. Detector Coil Assem.	.75
S-15694	L3	Broadcast Osc. Coil Assem.	.65
S-15733	L4	F.M. Osc. Coil Assem.	.55
<u>CONDENSERS</u>			
22-3	C6	.01 Mfd. Ceramic (8 used)	500V .26
22-4	C25	.004 Mfd. Ceramic	500V .26
22-5	C7	110 Mmfd. Ceramic (Disc.)(2 used)	500V .26
22-6	C22	470 Mmfd. Ceramic	500V .26
22-229	C21	.005 Mfd.	500V .20
22-448	C13	.004 Mfd.	600V .20
22-829	C11	.05 Mfd.	200V .20
22-830	C15	.02 Mfd.	600V .20
22-1126	C23	.01 Mfd.	400V .20
22-1158	C16	.05 Mfd.	200V .20
22-1220	C14	.002 Mfd.	600V .20
22-1367	C9	50 Mmfd. Ceramic	500V .33
22-1506	C8	22 Mmfd. Ceramic (2 used)	500V .33
22-1676	C20	.001 Mfd. Ceramic (3 used)	500V .40
22-1742	C1	Two Section Gang Cond.	3.00
22-1757	C17,C18	Elect. Cond. - 40 Mfd. -150Vx80 Mfd.	150V 2.50
22-1766	C10	.68 Mmfd. Ceramic	500V .20
22-1775	C24	.047 Mfd.	400V .26
22-1852	C5	7.5 Mmfd. Ceramic	500V .35
22-1887	C19	25 Mmfd. Ceramic	500V .26
22-2112	C27	.001 Mfd. Ceramic	500V .30
22-2276	C26	Dual Ceramic Cond. -.01 Mfd. -.01 Mfd.	500V .50
<u>RESISTORS</u>			
63-686	R18	150 Ohm W.W. 1/2W 10% Ins. Res.	.21
63-1450	R13	22 Ohm W.W. 1W 20% Ins. Res.	.24
63-1744	R2	100 Ohm W.W. 1/2W 20% (2 used) Ins.Res.	.21
63-1758	R5	220 Ohm W.W. 1/2W 20% (6 used) Ins.Res.	.21

PART NO.	DIAG. NO.	DESCRIPTION	PRICE
63-1782	R11	820 Ohm W.W. 1/2W 10% Ins. Res.	.21
63-1800	R14	2200 Ohm W.W. 1/2W 20% (2 used) Ins.Res.	.21
63-1828	R4	10K Ohm W.W. 1/2W 20% Ins. Res.	.21
63-1835	R15	15K Ohm W.W. 1/2W 20% Ins. Res.	.21
63-1856	R19	47K Ohm W.W. 1/2W 20% Ins. Res.	.21
63-1870	R8	100K Ohm W.W. 1/2W 20% (4 used) Ins.Res.	.21
63-1876	R16	150K Ohm W.W. 1/2W 10% (2 used) Ins.Res.	.21
63-1898	R17	470K Ohm W.W. 1/2W 20% (2 used) Ins.Res.	.21
63-1912	R9	1 Megohm W.W. 1/2W 20% Ins. Res.	.21
63-1926	R7	2.2 Megohm W.W. 1/2W 20%(2 used) Ins.Res.	.21
63-1940	R3	4.7 Megohm W.W. 1/2W 20% (3 used) Ins. Res.	.21
63-2143	R10	Volume Control & Switch	1.81
63-2144	R20	Tone Control	1.20
63-2424	R21	39 Ohm W.W. 1W 10% Ins. Res.	.30
63-3137	R12	1000 Ohm W.W. 5W 20% Ins. Res.	
<u>MISCELLANEOUS</u>			
11-85		Line Cord & Plug (6 ft. lg)	.65
12-1070		Wavemagnet Mtg. Brkt.	.25
14-1273		Plastic Cabinet for H724Z1	5.50
16-657		Packing Carton	
43-165		Handle Housing	1.00
49-689	SP1	5 1/4" PM Speaker	6.00
		ZC 5091 Cone & Voice Coil	1.73
		TS2035 Output Trans.	1.40
54-129		Speed Nut (9 used on Baffle & Grill Cloth)	.01
54-279		3/8-32x1/2" Hex Nut Steel St. Br.(used on chassis)	.02
57-1717		Chassis Bottom Plate	.30
57-1721		Emblem Plate	.25
58-200		Two Prong A.C. Plug	
78-806		Miniature Tube Socket	.15
78-850		Miniature Tube Socket	.35
78-869		Miniature Tube Socket	.20
78-870		Miniature Tube Socket (3 used)	.15
78-871		Miniature Tube Socket	.15
80-884		Ground Spring	
83-1056		Wavemagnet Mtg. Strip	.03
83-1789		Handle Strip (Rubber) (1/2 used)	.07
83-1829		Insulator Strip	.07
83-1931		Handle Strip (Rubber)(1/2 used)	.10
85-516	S1	Band Switch	
93-94		Ins. Shoulder Washer (used with 85-516)	.01
93-487		1/16x.144x3/8 Washer (2 used on 43-165)	.01
93-1097		Insulating Washer (used with 85-516)	
94-485		Insulating Bushing (used with 85-516)	.03
97-293		Chassis Mtg. Stud (2 used)	.18
110-180		Grill Cloth	
112-281		#10x3/4 Truss Hd. St. St. Br (2 used on Chassis Mtg.)	.02
114-297		#6x1/4" Hex. Hd. S.T. (6 used on 57-1717)	.01
114-356		#6x1 1/4" Hex.Hd.S.T.(used on 212-7)	.02
114-366		#6x3/8 Hex. Hd. S.T. (2 used on 43-165)	.02
126-618		Tube Shield	.02
139-98		Speaker Baffle	
149-64		Iron Core & Spring (2 used)	.40
159-69		Plug Button (4 used on S-17366)	.01
196-153		Speaker Gasket	.40
199-103		Flexible Handle Sleeve	.35
202-697		F.M. Inst. Book	.10
202-897		Instruction Book	
212-7	SE1	Selenium Rectifier	1.80
S-13210		Strap & Rivet Assem. (Handle)	.20
S-14957	L5	Wavemagnet Assem.	1.25
S-17366		Cabt. Back Assem (complete)	1.50
S-18434		Band Switch Ext. Shaft Assem.	

MODEL H724Z2, Ch. 7H02Z2

The 7H02Z2 chassis incorporates a superheterodyne circuit with two stages of IF, on the FM Band, and two stages on the AM Band. There is one stage of RF amplification on the FM Band.

When adjustments are made on the 7H02Z2 or any AC-DC chassis, a line isolation transformer (110-V input to 110-V output) is recommended in order to avoid a "hot" chassis. If an isolation transformer is not available, check the AC voltage between chassis and bench ground, and if there is any indication of voltage, reverse the plug before handling the set.

The I.F. transformers and the discriminator transformer are the new permeability tuned type. The advantage of an IF transformer of this type is its extreme stability under various humidity and temperature conditions. The upper coil is the secondary and the lower the primary. When adjusting these IF and discriminator transformers, tuning wrench 68-19 can be inserted into the top slug, rotated until maximum output is obtained and then dropped down to the lower slug and the same operation repeated. The tuning wrench is so designed that turning one slug does not affect the adjustment of the other.

FM IF Alignment: Reasonably accurate alignment can be made by following the procedure outlined in this service note.

FM Discriminator Alignment: When the secondary of the discriminator is aligned (operation 5) use sufficient signal input to get a good positive and negative indication before setting the slug for zero reading. A center zero indicating meter is recommended for this adjustment, but is not absolutely necessary. Reversing the leads of a non-zero center meter, or observing closely when the meter starts to go to the left (negative) of zero will give the same results.

Alignment of this chassis will, in most cases, be unnecessary unless an IF or RF transformer is replaced or the adjustments have been tampered with.

Correct alignment can only be made if the following procedure is followed:

A vacuum tube voltmeter with an isolation resistor of 2,000,000 ohms in series with the hot lead will serve for FM adjustments. This lead should be shielded.

An AC output meter connected across the primary or secondary of the output transformer will be satisfactory for all AM adjustments.

The signal generator output should be kept just high enough to get an indication on the meter.

(a) Vacuum Tube Voltmeter Lug 7 on discriminator transformer to chassis (half discriminator load).

(b) Vacuum Tube Voltmeter Lug 5 on discriminator transformer to chassis (full discriminator load).

(c) Vacuum Tube Voltmeter from Limiter Grid to Chassis.

(d) Loosen Slugs by applying a hot iron to the cement.

MODEL H724Z2,
Ch. 7H02Z2

TUBE AND TRIMMER LOCATION

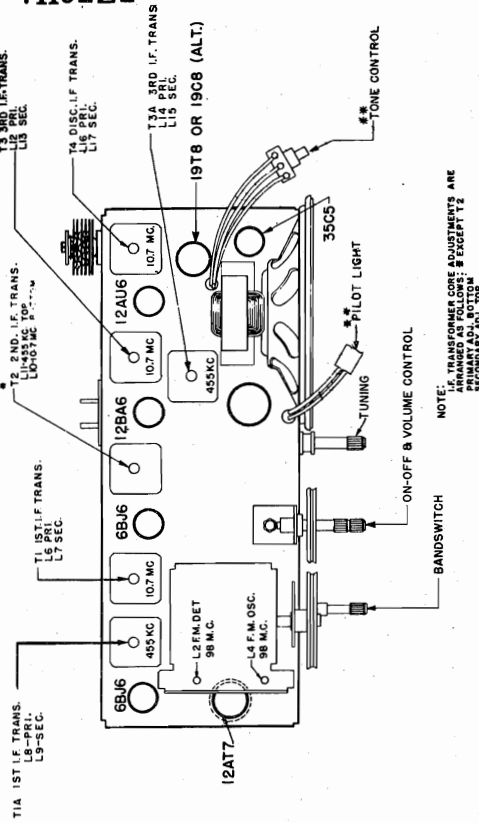

NOTE: I.F. TRANSFORMER CORE ADJUSTMENTS ARE ARRANGED AS FOLLOWS: * EXCEPT T2 SECONDARY ADJ. TOP

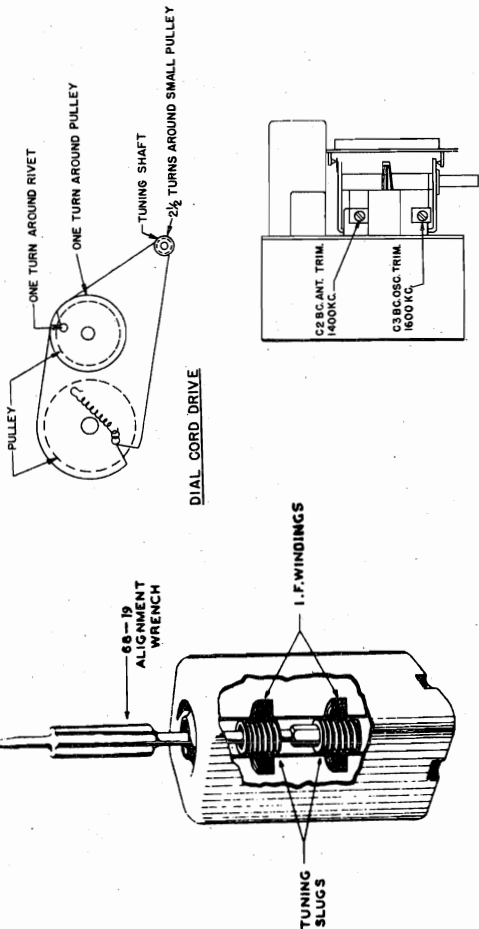

Detail of IF Transformer

ALIGNMENT PROCEDURE

Operation	Connect Oscillator to	Dummy Antenna	Input Signal Frequency	Band	Set Dial To	Adj. Trimmers	Purpose
1	Pin 2 12AT7 Converter	.05 Mfd.	455 Kc. Modulated	BC	600 Kc.	L8, 9, 11, 14, 15	Align I. F. channel for maximum output.
2	2 turns loosely cpl'd. to wavemagnet		1600 Kc. Modulated	BC	1600 Kc.	C3	Set oscillator to dial scale.
3	2 turns loosely cpl'd. to wavemagnet		1400 Kc. Modulated	BC	1400 Kc.	C2	Align antenna stage.
4 (a)	Pin 1 (grid) on 12AU6 limiter.	.05 Mfd.	10.7 Mc. Unmodulated	FM 100		L16 coil slug Primary discr.	Align primary of discriminator for maximum reading.
5 (b)	Pin 1 (grid) on 12AU6 limiter	.05 Mfd.	10.7 Mc. Unmodulated	FM 100		L17 coil slug sec. of discr.	Adjust secondary of discriminator for zero reading.
6 (c)	Pin 1 (grid) on 12BA6 2nd IF.	.05 Mfd.	10.7 Mc. Unmodulated	FM 100		L12 and L13 Prim. and Sec. of 3rd IF trans.	Align 3rd IF transformer for maximum reading.
7 (c)	Pin 1 (grid) on 6B7 1st IF.	.05 Mfd.	10.7 Mc. Unmodulated	FM 100		L10 Prim. of 2nd IF transformer	Align 2nd IF transformer for maximum reading.
8 (c)	Pin 2 (grid) on 12AT7 converter tube socket.	.05 Mfd.	10.7 Mc. Unmodulated	FM 100		L6 and L7 Prim. and Sec. of 1st IF transformer	Align 1st IF transformer for maximum reading.
9 (c)	Antenna Post FM (Re-move line ant.)	270 ohms	98 Mc. Unmodulated	FM 100	98 Mc.	L4 Osc. Coil Slug	Set oscillator to dial scale.
10 (c) (d)		270 ohms	98 Mc. Unmodulated	FM 100	98 Mc.	L2 Det. Coil Slug	Align det. stage to maximum reading

MODEL H723Z2,
Ch. 7H04Z2

MODEL H724Z2 CHASSIS 7H02Z2

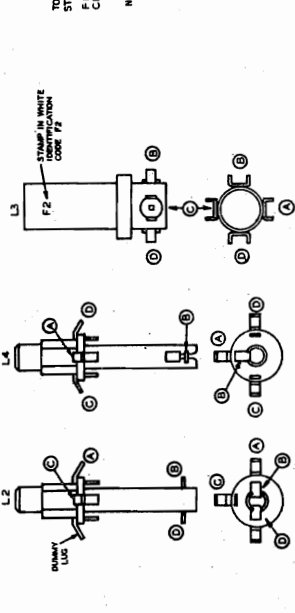
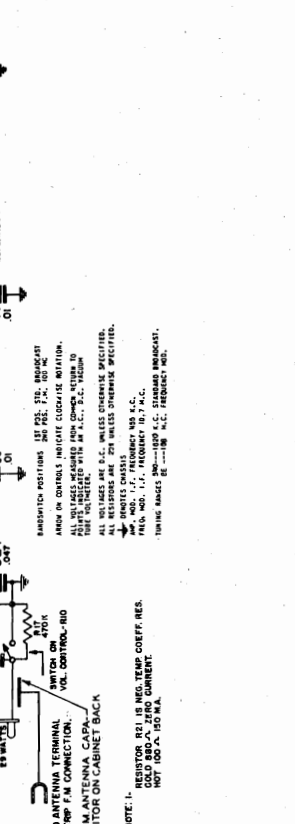
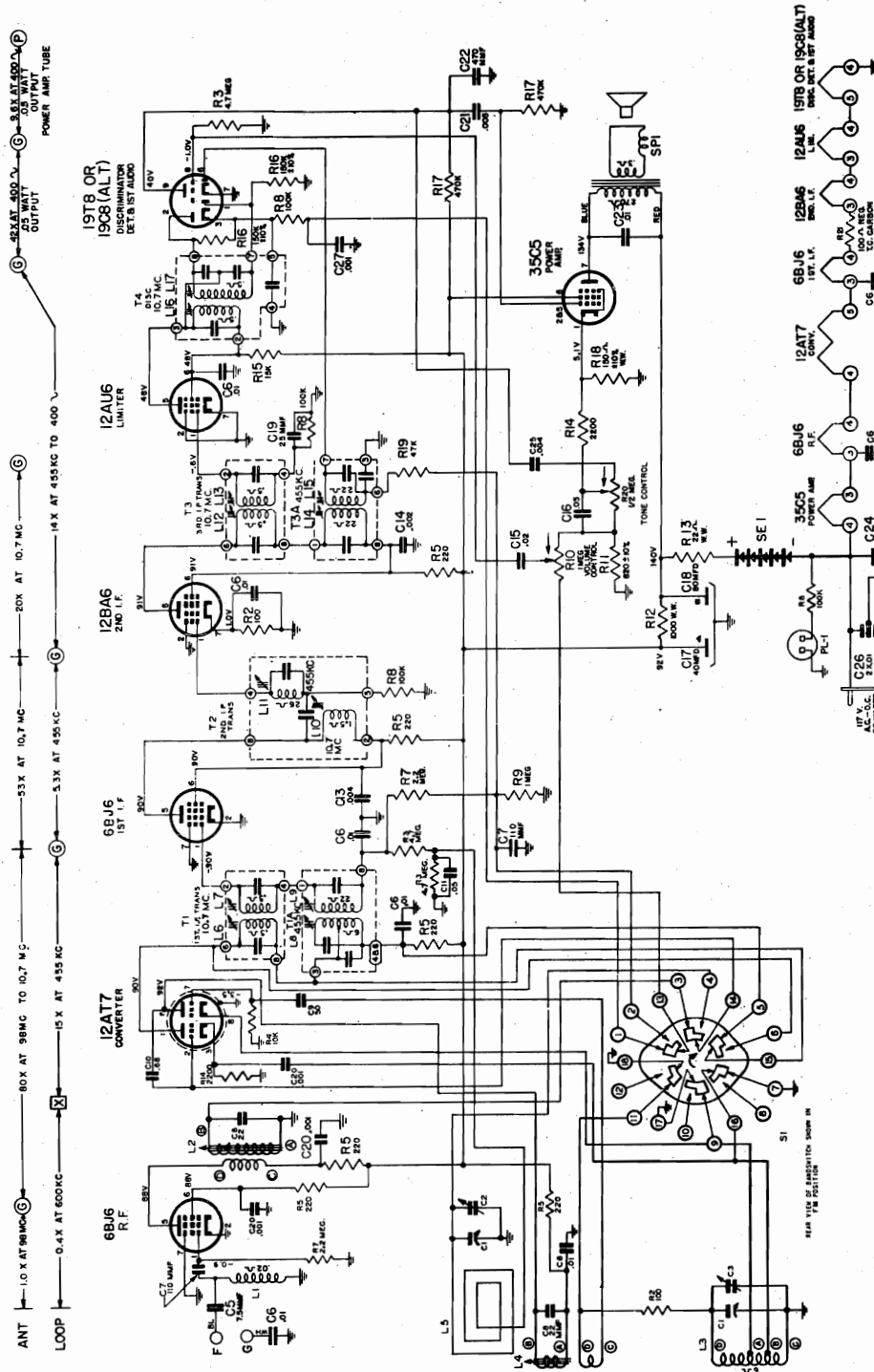

NOTE: 1. RESISTORS R1, R2, R3, R4, R5, R6, R7, R8, R9, R10, R11, R12, R13, R14, R15, R16, R17, R18, R19, R20, R21, R22, R23, R24, R25, R26, R27, R28, R29, R30, R31, R32, R33, R34, R35, R36, R37, R38, R39, R40, R41, R42, R43, R44, R45, R46, R47, R48, R49, R50, R51, R52, R53, R54, R55, R56, R57, R58, R59, R60, R61, R62, R63, R64, R65, R66, R67, R68, R69, R70, R71, R72, R73, R74, R75, R76, R77, R78, R79, R80, R81, R82, R83, R84, R85, R86, R87, R88, R89, R90, R91, R92, R93, R94, R95, R96, R97, R98, R99, R100, R101, R102, R103, R104, R105, R106, R107, R108, R109, R110, R111, R112, R113, R114, R115, R116, R117, R118, R119, R120, R121, R122, R123, R124, R125, R126, R127, R128, R129, R130, R131, R132, R133, R134, R135, R136, R137, R138, R139, R140, R141, R142, R143, R144, R145, R146, R147, R148, R149, R150, R151, R152, R153, R154, R155, R156, R157, R158, R159, R160, R161, R162, R163, R164, R165, R166, R167, R168, R169, R170, R171, R172, R173, R174, R175, R176, R177, R178, R179, R180, R181, R182, R183, R184, R185, R186, R187, R188, R189, R190, R191, R192, R193, R194, R195, R196, R197, R198, R199, R200, R201, R202, R203, R204, R205, R206, R207, R208, R209, R210, R211, R212, R213, R214, R215, R216, R217, R218, R219, R220, R221, R222, R223, R224, R225, R226, R227, R228, R229, R230, R231, R232, R233, R234, R235, R236, R237, R238, R239, R240, R241, R242, R243, R244, R245, R246, R247, R248, R249, R250, R251, R252, R253, R254, R255, R256, R257, R258, R259, R260, R261, R262, R263, R264, R265, R266, R267, R268, R269, R270, R271, R272, R273, R274, R275, R276, R277, R278, R279, R280, R281, R282, R283, R284, R285, R286, R287, R288, R289, R290, R291, R292, R293, R294, R295, R296, R297, R298, R299, R300, R301, R302, R303, R304, R305, R306, R307, R308, R309, R310, R311, R312, R313, R314, R315, R316, R317, R318, R319, R320, R321, R322, R323, R324, R325, R326, R327, R328, R329, R330, R331, R332, R333, R334, R335, R336, R337, R338, R339, R340, R341, R342, R343, R344, R345, R346, R347, R348, R349, R350, R351, R352, R353, R354, R355, R356, R357, R358, R359, R360, R361, R362, R363, R364, R365, R366, R367, R368, R369, R370, R371, R372, R373, R374, R375, R376, R377, R378, R379, R380, R381, R382, R383, R384, R385, R386, R387, R388, R389, R390, R391, R392, R393, R394, R395, R396, R397, R398, R399, R400, R401, R402, R403, R404, R405, R406, R407, R408, R409, R410, R411, R412, R413, R414, R415, R416, R417, R418, R419, R420, R421, R422, R423, R424, R425, R426, R427, R428, R429, R430, R431, R432, R433, R434, R435, R436, R437, R438, R439, R440, R441, R442, R443, R444, R445, R446, R447, R448, R449, R450, R451, R452, R453, R454, R455, R456, R457, R458, R459, R460, R461, R462, R463, R464, R465, R466, R467, R468, R469, R470, R471, R472, R473, R474, R475, R476, R477, R478, R479, R480, R481, R482, R483, R484, R485, R486, R487, R488, R489, R490, R491, R492, R493, R494, R495, R496, R497, R498, R499, R500, R501, R502, R503, R504, R505, R506, R507, R508, R509, R510, R511, R512, R513, R514, R515, R516, R517, R518, R519, R520, R521, R522, R523, R524, R525, R526, R527, R528, R529, R530, R531, R532, R533, R534, R535, R536, R537, R538, R539, R540, R541, R542, R543, R544, R545, R546, R547, R548, R549, R550, R551, R552, R553, R554, R555, R556, R557, R558, R559, R560, R561, R562, R563, R564, R565, R566, R567, R568, R569, R570, R571, R572, R573, R574, R575, R576, R577, R578, R579, R580, R581, R582, R583, R584, R585, R586, R587, R588, R589, R590, R591, R592, R593, R594, R595, R596, R597, R598, R599, R600, R601, R602, R603, R604, R605, R606, R607, R608, R609, R610, R611, R612, R613, R614, R615, R616, R617, R618, R619, R620, R621, R622, R623, R624, R625, R626, R627, R628, R629, R630, R631, R632, R633, R634, R635, R636, R637, R638, R639, R640, R641, R642, R643, R644, R645, R646, R647, R648, R649, R650, R651, R652, R653, R654, R655, R656, R657, R658, R659, R660, R661, R662, R663, R664, R665, R666, R667, R668, R669, R670, R671, R672, R673, R674, R675, R676, R677, R678, R679, R680, R681, R682, R683, R684, R685, R686, R687, R688, R689, R690, R691, R692, R693, R694, R695, R696, R697, R698, R699, R700, R701, R702, R703, R704, R705, R706, R707, R708, R709, R710, R711, R712, R713, R714, R715, R716, R717, R718, R719, R720, R721, R722, R723, R724, R725, R726, R727, R728, R729, R730, R731, R732, R733, R734, R735, R736, R737, R738, R739, R740, R741, R742, R743, R744, R745, R746, R747, R748, R749, R750, R751, R752, R753, R754, R755, R756, R757, R758, R759, R760, R761, R762, R763, R764, R765, R766, R767, R768, R769, R770, R771, R772, R773, R774, R775, R776, R777, R778, R779, R780, R781, R782, R783, R784, R785, R786, R787, R788, R789, R790, R791, R792, R793, R794, R795, R796, R797, R798, R799, R800, R801, R802, R803, R804, R805, R806, R807, R808, R809, R810, R811, R812, R813, R814, R815, R816, R817, R818, R819, R820, R821, R822, R823, R824, R825, R826, R827, R828, R829, R830, R831, R832, R833, R834, R835, R836, R837, R838, R839, R840, R841, R842, R843, R844, R845, R846, R847, R848, R849, R850, R851, R852, R853, R854, R855, R856, R857, R858, R859, R860, R861, R862, R863, R864, R865, R866, R867, R868, R869, R870, R871, R872, R873, R874, R875, R876, R877, R878, R879, R880, R881, R882, R883, R884, R885, R886, R887, R888, R889, R890, R891, R892, R893, R894, R895, R896, R897, R898, R899, R900, R901, R902, R903, R904, R905, R906, R907, R908, R909, R910, R911, R912, R913, R914, R915, R916, R917, R918, R919, R920, R921, R922, R923, R924, R925, R926, R927, R928, R929, R930, R931, R932, R933, R934, R935, R936, R937, R938, R939, R940, R941, R942, R943, R944, R945, R946, R947, R948, R949, R950, R951, R952, R953, R954, R955, R956, R957, R958, R959, R960, R961, R962, R963, R964, R965, R966, R967, R968, R969, R970, R971, R972, R973, R974, R975, R976, R977, R978, R979, R980, R981, R982, R983, R984, R985, R986, R987, R988, R989, R990, R991, R992, R993, R994, R995, R996, R997, R998, R999, R1000.

MODEL H724Z2,
Ch. 7H02Z2

PARTS LIST

PART NO.	DIAG. NO.	DESCRIPTION	PRICE	PART NO.	DIAG. NO.	DESCRIPTION	PRICE	
H724Z2 Maroon-Grey-Green (Chassis 7H02Z2)								
26-463		Dial Scale	1.50	22-448	C13	.004 Mfd.	600V	
46-859		Bandswitch Knob (Maroon Model only)	.15	22-829	C11	.05 Mfd.	200V	
46-860		Tuning Control Knob (Maroon Model only)	.15	22-830	C15	.02 Mfd.	600V	
46-900		Volume Control Knob (Maroon Model only)	.15	22-1126	C23	.01 Mfd.	400V	
46-901		Tone Control Knob (Maroon Model only)	.10	22-1158	C16	.05 Mfd.	200V	
46-962		Bandswitch Knob (Grey Model only)	.20	22-1620	C14	.002 Mfd.	600V	
46-963		Tuning Control Knob (Grey Model only)	.15	22-1367	C9	50 Mmfd. Ceramic	500V	
46-964		Volume Control Knob (Grey Model only)	.15	22-1506	C8	22 Mmfd. Ceramic (2 used)	500V	
46-965		Tone Control Knob (Grey Model only)	.15	22-1676	C20	.001 Mfd. Ceramic (3 used)	500V	
46-966		Bandswitch Knob (Green Model only)	.20	22-1742	C1	Two Section Gang Cond.	3.00	
46-967		Tuning Control Knob (Green Model only)	.15	22-1757	C17,18	Elect. Cond. -40 Mfd. -150Vx80Mfd.	150V	
46-968		Volume Control Knob (Green Model only)	.15	22-1766	C10	.58 Mmfd. Ceramic	2.50	
46-969		Tone Control Knob (Green Model only)	.15	22-1775	C24	.047 Mfd.	200V	
59-251		Dial Pointer	.70	22-1852	C5	7.5 Mmfd. Ceramic	35	
78-932		Dial Light Socket Assembly	.40	22-1887	C19	25 Mmfd. Ceramic	26	
80-69		Dial Cord Tension Spring	.05	22-2112	C27	.001 Mfd. Ceramic	30	
80-444		Tuner Arm Tension Spring	.05	22-2276	C26	Dual Ceramic Cond. -.01 Mfd. -.01 Mfd. 500V	.50	
80-580		Tuner Arm Stop Spring	.06					
80-817		Tuner Spring	.06					
80-818		Tuner Arm Pressure Spring	.12					
100-105	PL1	Neon Indicator Bulb	.11					
171-11		Pilot Light Jewel	.20					
188-150		Retaining Ring (1 used on S-17334 & 1 read with S-17467)	.02	63-686	R18	150 Ohm WW 1W 10% Ins.	Res.	
S-14524		Cond. Pulley & Cam Assembly	.55	63-1450	R13	22 ohm	Res.	
S-17334		Tuner Arm Assembly	.45	63-1744	R2	100 ohm	Res. (2 used)	
S-17336		Tuning Shaft & Pulley Assembly	.45	63-1758	R5	220 ohm	Res. (6 used)	
S-17467		Tuning Shaft Brkt. & Ins. Strip Assem.	.15	63-1782	R11	820 ohm	Res.	
S-18442		Brkt. & Pulley Assembly	.60	63-1800	R14	2200 ohm	Res. (2 used)	
		Dial Cord & Eyelet Assembly	.10	63-1828	R4	10K ohm	Res. (2 used)	
				63-1835	R15	15K ohm	Res.	
				63-1856	R19	47K ohm	Res.	
				63-1870	R8	100K ohm	Res.	
				63-1876	R16	150K ohm	Res. (4 used)	
				63-1898	R17	470K ohm	Res. (2 used)	
				63-1912	R9	1 Megohm	Res. (3 used)	
				63-1926	R7	2.2 Megohm	Res. (2 used)	
				63-1940	R3	4.7 Megohm	Res. (3 used)	
				63-2143	R10	4.7 Megohm	Res. (2 used)	
				63-2144	R20	Volume Control & Switch	1.81	
				63-2797	R21	Tone Control	1.20	
				63-3137	R12	Special Resistor	.85	
						1000 ohm WW 5W 20% Ins.	.70	
				Resistors				
				11-85		Line Cord & Plug (6 ft. lg.)	.65	
				12-1070		Wavemagnet Mtg. Brkt.	.25	
				14-1273		Plastic Cabinet for H724Z2-Maroon Table Model	5.50	
				14-1398		Plastic Cabinet for H724Z2-Grey Table Model	8.50	
				14-1399		Plastic Cabinet for H724Z2-Green Table Model	8.50	
				16-657		Packing Carton	1.00	
				43-165		Handle Housing	.20	
				Condensers				
22-3	C6	.01 Mfd. Ceramic (8 used)	500V	11-85		Line Cord & Plug (6 ft. lg.)	.65	
22-4	C25	.004 Mfd. Ceramic	500V	12-1070		Wavemagnet Mtg. Brkt.	.25	
22-5	C7	110 Mmfd. Ceramic (2 used)	500V	14-1273		Plastic Cabinet for H724Z2-Maroon Table Model	5.50	
22-6	C22	470 Mmfd. Ceramic	500V	14-1398		Plastic Cabinet for H724Z2-Grey Table Model	8.50	
22-229	C21	.005 Mfd.	500V	14-1399		Plastic Cabinet for H724Z2-Green Table Model	8.50	

Prices shown are suggested list prices, and are subject to change without notice.

2/18/52

The 8H20Z chassis incorporates a superheterodyne circuit with two stages of IF, on the FM Band, and one stage on the AM Band. There is one stage of RF amplification on all Bands.

When adjustments are made on the 8H20Z chassis, a line isolation transformer (110 V input to 110V output) is recommended in order to avoid a "hot" chassis. If an isolation transformer is not available, check the AC voltage between chassis and bench ground and if there is any indication of voltage, reverse the plug before handling the set.

FM RF Alignment: The tuning slugs are attached to threaded shafts and the slugs are varied in the field of the coils by turning the shafts clockwise or counter-clockwise. After adjustment the shafts must be secured with a drop of speaker cement.

AM and FM IF Alignment: The AM and FM IF transformers in this receiver are of the new permeability tuned type. The advantage of an IF transformer of this type is its extreme stability under various humidity and temperature conditions. The upper coil is the secondary and the lower the primary. When adjusting these IF transformers the tuning wrench 68-19 can be inserted into the

top slug, rotated until maximum output is obtained and then dropped down to the lower slug and the same operation repeated. The tuning wrench is so designed that turning one slug does not affect the adjustment of the other.

FM IF Alignment: Because of the wide band pass, it is desirable to use a FM signal generator and a cathode ray oscilloscope when aligning the FM IF channel. The instruction book for the Zenith Model 800 Signal Generator (Form Z8001) covers complete FM alignment procedure. If visual alignment equipment is unavailable, reasonably accurate alignment can be made by following the procedure outlined below.

FM Discriminator Alignment: When the secondary of the discriminator is aligned (operation 5) use sufficient signal input to get a good positive and negative indication before setting the slug for zero reading. A center zero indicating meter is recommended for this adjustment, but is not absolutely necessary. Reversing the leads of a non-zero center meter, or observing closely when the meter starts to go to the left (negative) of zero will give the same results.

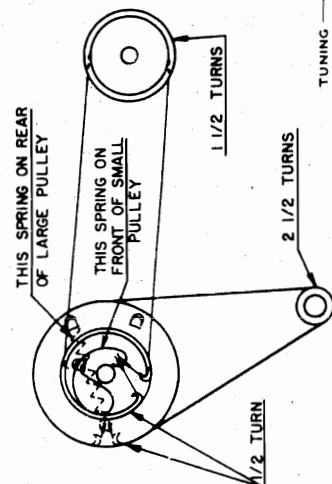
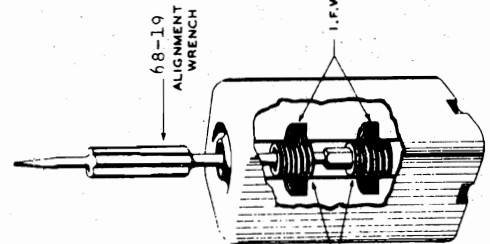
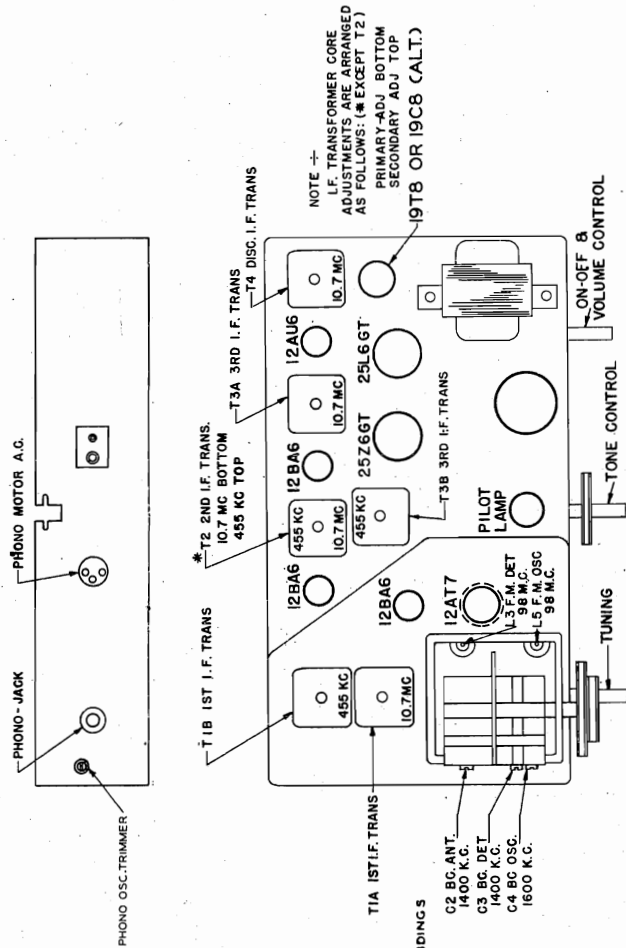

TUBE AND TRIMMER LOCATION

MODELS J880, J880R,
Waldorf, Ch. 8H20Z

ALIGNMENT PROCEDURE

Operation	Connect Oscillator To	Dummy Antenna	Input Signal Frequency	Band	Set Dial To	Adj. Trimmers	Purpose
1	Pin 2 12AT7 Converter 2 turns loosely cpld. to wavemagnet	.05 Mfd.	455 Kc. Modulated	BC	600 Kc.	L9, 10, 12 15 & 16	Align I. F. channel for maximum output.
2	2 turns loosely cpld. to wavemagnet		1600 Kc. Modulated	BC	1600 Kc.	C4	Set oscillator to dial scale.
3	2 turns loosely cpld. to wavemagnet		1400 Kc. Modulated	BC	1400 Kc.	C3, C2	Align detector and antenna stage.
4 (a)	Pin 1 (grid) on 12AU6 limiter.	.05 Mfd.	10.7 Mc. Unmodulated	FM		L17 coil slug Primary discr.	Align primary of discriminator for maximum reading.
5 (b)	Pin 1 (grid) on 12AU6 limiter.	.05 Mfd.	10.7 Mc. Unmodulated	FM		L18 coil slug sec. of discr.	Adjust secondary of discriminator for zero reading.
6 (c)	Pin 1 (grid) on 12BA6 2nd. I.F.	.05 Mfd.	10.7 Mc. Unmodulated	FM		L13 and L14 Pri. & Sec. of 3rd. IF trans.	Align 3rd. IF transformer for maximum reading.
7 (c)	Pin 1 (grid) on 12BA6 1st. IF.	.05 Mfd.	10.7 Mc. Unmodulated	FM		Adjust L11 for maximum reading.	Align 2nd IF transformer for maximum reading.
8 (c)	Pin 2 (grid) on 12AT7 converter tube socket.	.05 Mfd.	10.7 Mc. Unmodulated	FM		L7 and L8 Prim. and Sec. of 1st. IF transformer.	Align 1st. IF transformer for maximum reading.
9 (c)	Antenna Post FM (Re- move line ant.)	270 ohms	98 Mc. Unmodulated	FM	98 Mc.	L5 Osc. Coil Slug.	Set Oscillator to dial scale.
10 (c) (d)		270 ohms	98 Mc. Unmodulated	FM	98 Mc.	L3 Det. Coil Slug	Align det. stage to maximum reading.

IMPORTANT

Alignment of this chassis will in most cases be unnecessary unless an IF or RF transformer is replaced or the adjustments have been tampered with.
Correct alignment can only be made if the following procedure is followed:
A vacuum tube voltmeter with an isolation resistor of 2,000,000 ohms in series with the hot lead will serve for FM adjustments. This lead should be shielded.
An AC output meter connected across the primary or secondary of the output transformer will be satisfactory for all AM adjustments.

The signal generator output should be kept just high enough to get an indication on the meter.
(a) Vacuum Tube Voltmeter Lug 7 on discriminator transformer to chassis (half discriminator load).
(b) Vacuum Tube Voltmeter Lug 5 on discriminator transformer to chassis (full discriminator load).
(c) Vacuum Tube Voltmeter from Limiter Grid to Chassis.
(d) Loosen Slugs by applying a hot iron to the cement.

MODELS J880, J880R, Ch. 8H20Z

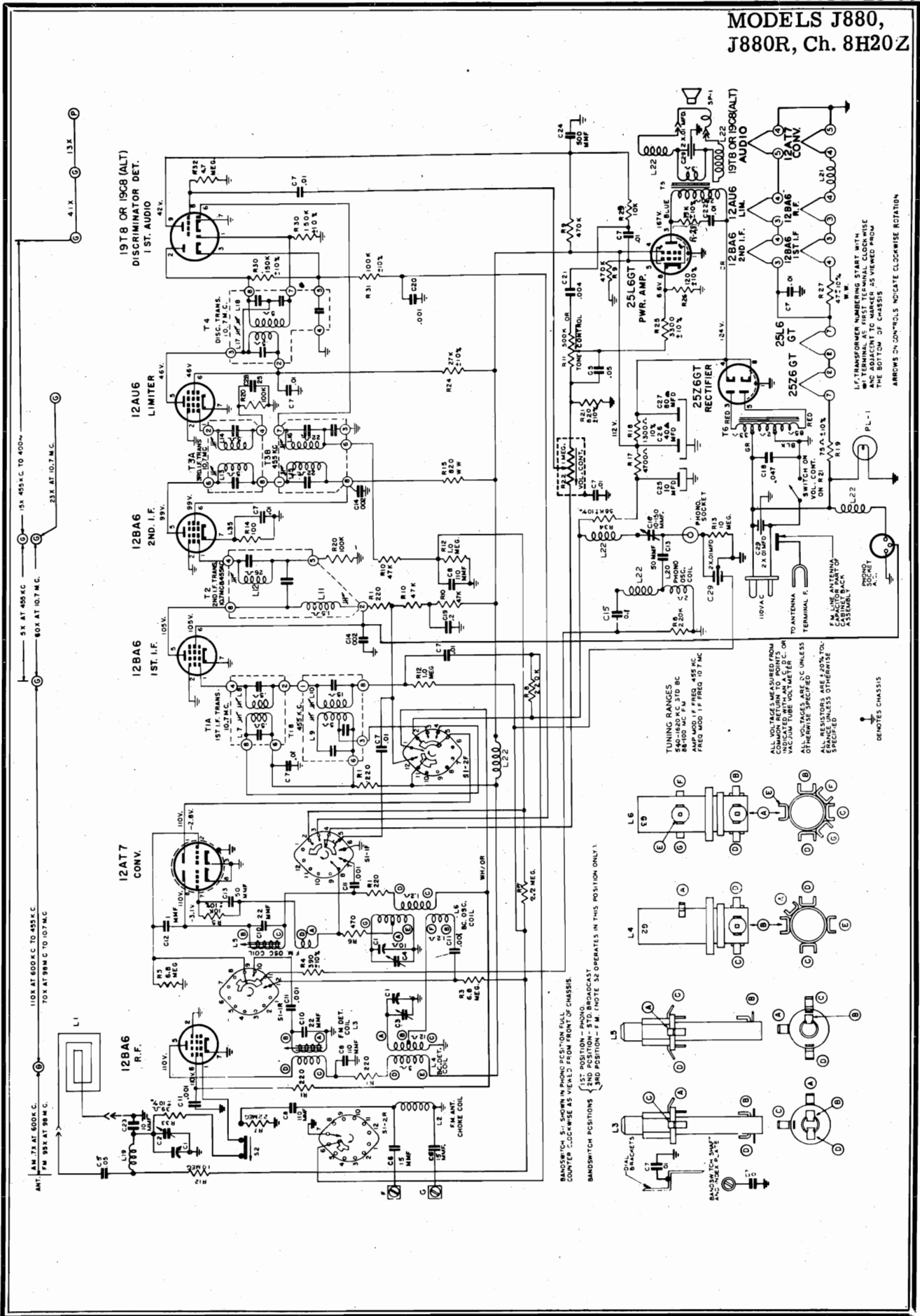

MODELS J880,
J880R, Ch. 8H20Z

PARTS LIST

Part No.	Diag. No.	Description	Price	Part No.	Diag. No.	Description	Price
<u>Dial Assembly</u>							
78-895		Dial Light Socket & Wire	.45	22-1506	C10	22 Mmfd. Ceramic	.33
80-69		Dial Cord Spring	.05	22-1507	C28	25 Mmfd. Ceramic	.33
80-746		Pulley Retaining Spring	.02	22-1676	C11	.001 Mfd. Ceramic	.40
80-747		Dial Cord Spring	.10	22-1717	C20	.001 Mfd.	.20
114-262		8-32 x 7/16" x 1/4" A. F. Hex Hd. S. T. (2 used on S-17149)	.02	22-1762	C12	1 Mmfd. Ceramic	.26
114-297		6-32 x 1/4" lg. x 1/4" Hex. Hd. (2 used on S-17165)	.01	22-1775	C18	.047 Mfd. (Molded)	.25
148-122		Tuner Arm	.20	22-1863	C23	10 Mmfd. Ceramic	3.80
188-30		Retaining Ring (Used on S-17155)	.02	22-2104	C1	Three Section Variable	3.00
S-17149		Dial Scale & Brkt. Assem.	1.50	22-2105	C26, 27	Elect. 80-40 Mfd.	.20
S-17155		Tuning Shaft & Pulley Assem.	.35	22-2140	C6	15 Mmfd. Ceramic	1.25
S-17157		Pointer & Pulley Assem.	.55	22-2154	C25	Elect. 10 Mfd.	.40
S-17158		Dial Cord & Eyelet Assem. (Long)	.07	22-2240	C16	Trimmer Cond.	.50
S-17159		Dial Cord & Eyelet Assem. (Short)	.06	22-2276	C29	Dual Ceramic .01 Mfd. (3 used) 500V	
S-17165		Brkt. & Pulley Bushing Assem.	.35	<u>Resistors</u>			
<u>Coils & Chokes</u>							
20-337	L22	R. F. Choke Coil (6 Used)	.20	63-1726	R33	39 Ohm	.21
95-1102	T3B	2nd. I. F. Trans.	1.60	63-1744	R14	100 Ohm	.21
95-1150	T3A	2nd. I. F. Trans.	1.50	63-1758	R1	220 Ohm	.21
95-1153	T4	Discriminator Transf.	1.50	63-1768	R4	390 Ohm	.21
95-1201	T1A	1st. I. F. Trans.	1.50	63-1772	R6	470 Ohm	.21
95-1248	T1B	1st. I. F. Trans.	1.60	63-1782	R21	820 Ohm	.21
95-1251	T2	2nd. I. F. Trans.	1.65	63-1806	R25	3300 Ohm	.21
S-12603	L20	Phono Osc. Coil Assem.	.75	63-1814	R17	4700 Ohm	.21
S-13997	L21	Filament Choke Coil Assem.	.40	63-1827	R5	10K Ohm	.21
S-15691	L5	F. M. Osc. Coil Assem.	.40	63-1828	R29	10K Ohm	.21
S-15743	L3	F. M. Detector Coil Assem.	.65	63-1834	R28	15K Ohm	.21
S-16344	L4	Broadcast Detector Coil Assem.	.60	63-1856	R24	27K Ohm	.21
S-16345	L6	Broadcast Osc. Coil Assem.	.60	63-1859	R34	56K Ohm	.21
S-16408	L2	Antenna Choke Coil Assem.	.25	63-1870	R20	100K Ohm	.21
<u>Condensers</u>							
22-3	C7	.01 Mfd. Ceramic	.26	63-1876	R30	150K Ohm	.21
22-4	C21	.004 Mfd. Ceramic	.26	63-1884	R8	220K Ohm	.21
22-5	C8	110 Mmfd. Ceramic (or 22-1669) (3 used)	.26	63-1898	R9	470K Ohm	.21
22-177	C19	.2 Mfd.	.33	63-1912	R12	1 Megohm	.21
22-669	C22	.01 Mfd.	.23	63-1926	R7	2.2 Megohm	.21
22-827	C15	.1 Mfd.	.20	63-1940	R32	4.7 Megohm	.21
22-829	C5	.05 Mfd.	.20	63-1947	R3	6.8 Megohm	.21
22-854	C24	.0005 Mfd.	.20	63-1954	R13	10 Megohm	.21
22-1220	C14	.002 Mfd.	.20	63-1981	R26	120 Ohm	.21
22-1367	C13	50 Mmfd. Ceramic	.33	63-2068	R18, 19	Two Section Candohm	1.00
<u>Insulators</u>							
22-177	C19	.2 Mfd.	.33	63-2093	R27	47 Ohm W. W. 1W 10% Ins. Res.	.24
22-827	C15	.1 Mfd.	.20	63-2131	R22	Volume Control & Switch	1.81
22-829	C5	.05 Mfd.	.20	63-2132	R11	Tone Control	1.20
22-854	C24	.0005 Mfd.	.20				
22-1220	C14	.002 Mfd.	.20				
22-1367	C13	50 Mmfd. Ceramic	.33				

PART NO.	DIAG. NO.	DESCRIPTION	PRICE	PART NO.	DIAG. NO.	DESCRIPTION	PRICE
44-25		Phono Jack	.12	57-1284		Strike Plate (2 used)	.05
54-139		3/8-32 x 9/16 Nut (1 ea. used on 63-2131 & 63-2132)	.01	57-1481		Esc. Clamping Plate (4 used)	.02
54-271		6-32 x 1/4" Nut steel cad. (1 ea. used on 95-1102-95-1150-1251-1153 & 2 ea. used on 95-1201 & 1248)		57-1658		Escutcheon	4.00
				57-1772		Chassis Bottom Plate	.30
				70-86		#6x5/8 Washer Hd. Wood Screw (12 used to Mt. Backs)	.60C
				72-81		#8x3/4 Phill Flt. Hd. Wood Screw St. Br. (6 used to Mt S-15536)	.02
58-128		Two Prong Plug	.15	78-847		Two Contact Socket (Cab. Back)	.10
78-755		Octal Tube Socket (2 used)	.18	80-604		Hinge Spring (2 used)	.15
78-869		Miniature Tube Socket	.20	80-830		Record Changer Mtg. Spring (4 used)	.03
78-870		Miniature Tube Socket (3 used)	.15	80-865		Ground Spring	.05
78-871		Miniature Tube Socket	.15	80-868		Ground Spring	.15
78-896		Three Contact Socket	.10	93-1059		Felt Washer (used on 46-873)	.01
78-903		Miniature Tube Socket (9 Contact)	.30	97-293		Chassis Mtg. Insulating Stud (3 used)	.18
80-780		Iron Core Tension Spring (3 used)	.05	100-97	PL1	Pilot Light Bulb	.25
80-865		Tuner Arm Tension Spring	.06	114-128		#10x1-1/16 Hex Washer Hd. S. T.	1.81C
80-781		Ground Spring (2 used)	.05			(3 used on chassis Mtg.)	.01
80-868		Ground Spring (2 used)	.05	114-297		#6x1/4" Hex Hd. S. T. Screw (used on 57-1772)	.02
85-505	S2	S.P.D. T. Switch (Ant.)	.90	114-341		#6x3/8" Hex Hd. S. T. (2 used on Esc. Mtg.)	.02
85-506	S1	Band Switch	3.25	114-350		#8x7/16" Hex Hd. S. T. (4 used on Esc. Mtg.)	.05
93-1039		Gang Mtg. Cup Washer (2 used)	.01	156-35		Bullet Catch (2 used)	.01
95-1188	T6	Auto Trans.	4.30	159-50		Plug Button (2 used on Esc. Mtg.)	.03
95-1272	T5	Speaker Output Trans.	2.00	165-9		Slide (2 used)	.03
126-618		Miniature Tube Shield	.02	165-14		Slide (2 used)	.03
149-95		Iron Core & Spring	.30	188-54		Knob Clamping Ring (46-876)	.50
S-16838		Speaker Cable & Eyelet Assem.	.35	192-138		Dial Glass	.10
				202-697		F.M. Instruction Book	.40
				202-893		Radio & Phono Instruction Book	--
				S-14029		Cobramatic Record Changer	--
				S-15536		Record Changer Compt. Hinge Brkt. & Link Assembly (2 used)	.50
				S-15780		Cobra Tone Arm Cartridge Assem.	3.50
2-256		Cabinet Back (Phono Section)	.65	S-16419		Record Adapter Plug & Envelope Assem.	.60
11-85		Line Cord & Plug 6 ft.	.65	S-16841	L1	Low Impedance Loop & Clip Assem.	.60
14-1335		Cabinet for J880 Console Combination Model	--	S-17005		Record Changer Mtg. Frame & Arm Assem.	8.00
14-1335R		Cabinet for J880R Console Combination Model	--	S-17167		Vol. Control Knob Assem.	.25
16-728		Packing Carton	--	S-17328	L19	Loop Loading Coil Assem.	.65
19-169		Record Changer	.07	S-17871		Cabinet Back Assem. (Complete)	3.00
23-23		Wire Connector (used on S-16841)	.05				
46-873		Tone Control Knob	.10				
46-876		Tuning Knob	.15				
46-899		Band Switch Knob	.15				
49-702	SP1	12" PM Speaker	10.00				
		ZC 1216E Cone & Voice Coil	4.60				

Prices shown are suggested list prices, and are subject to change without notice.

MODELS J1083E Wilshire, J1083EZ,
J1086 Westchester, J1086R, J1086RZ,
J1087 Picardy, J1087Z, Ch. 10H20Z

The 10H20Z chassis incorporates a superheterodyne circuit with two stages of IF, on the FM Band, and two stages on the AM Band. There is one stage of RF amplification on all bands.

FM RF Alignment: The tuning slugs are attached to threaded shafts and the slugs are varied in the field of the coils by turning the shafts clockwise or counter-clockwise. After adjustment the shafts must be secured with a drop of speaker cement.

AM and FM Alignment: The AM and FM IF transformers in this receiver are of the new permeability tuned type. The advantage of an IF transformer of this type is its extreme stability under various humidity and temperature conditions. The upper coil is the secondary and the lower the primary. When adjusting these IF transformers the tuning wrench 68-19 can be inserted into the top slug, rotated until maximum output is obtained and then dropped down to the lower slug and the same operation repeated. The tuning wrench is so designed that turning one slug does not affect the adjustment of the other.

FM IF Alignment: Because of the wide band pass, it is desirable to use a FM signal generator and a cathode ray oscilloscope when aligning the FM IF channel.

If visual alignment equipment is unavailable, reasonably accurate alignment can be made by following the procedure outlined below.

FM Discriminator Alignment: When the secondary of the discriminator is aligned (operation 5) use sufficient signal input to get a good positive and negative indication before setting the slug to zero reading. A center zero indicating meter is recommended for this adjustment, but is not absolutely necessary. Reversing the leads of a non-zero center meter, or observing closely when the meter starts to go to the left (negative) of zero will give the same results.

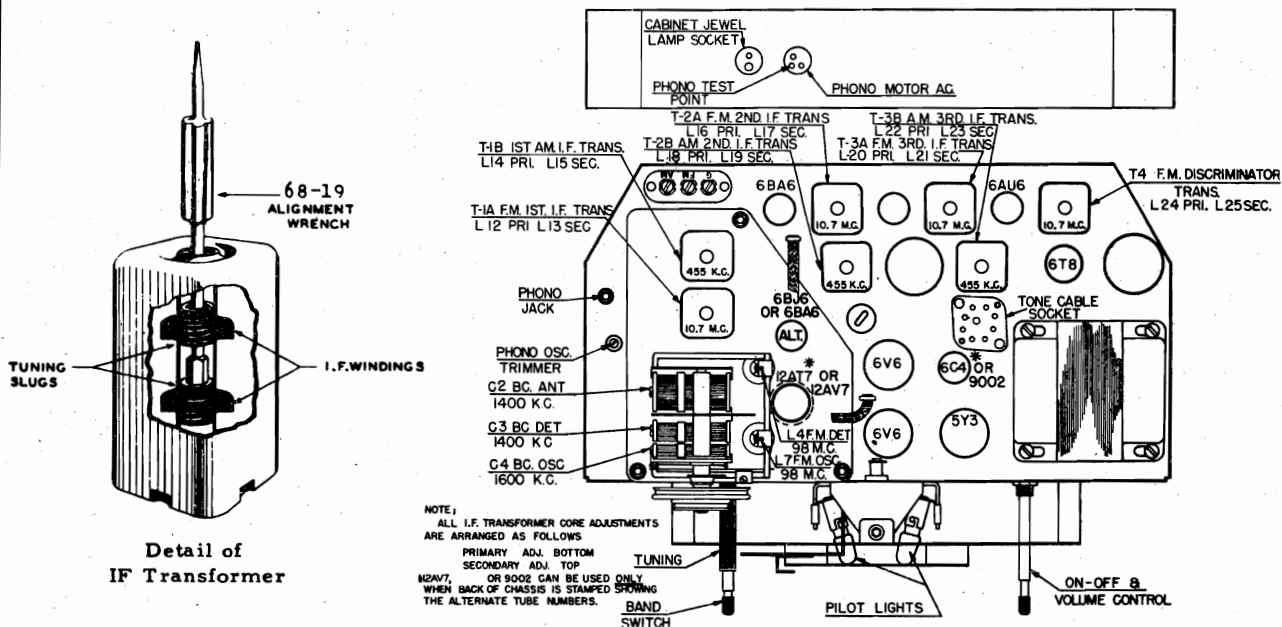

MODELS J1083E, J1083EZ, J1086,
J1086R, J1086RZ, J1087, J1087Z,
Ch. 10H20Z

ALIGNMENT PROCEDURE

Operation	Connect Oscillator To	Dummy Antenna	Input Signal Frequency	Band Set Dial To	Adj. Trimmers	Purpose
1	Pin 2 12AT7 or 12AV7 Converter 2 turns loosely cpid. to wavemagnet	.05 Mfd.	455 Kc. Modulated	BC 600 Kc.	Adj. Pri and Sec. T1B, T2B, T3B	Align I. F. channel for maximum output.
2	2 turns loosely cpid. to wavemagnet		Modulated 1400 Kc.	BC 1600 Kc.	C4	Set oscillator to dial scale.
3	2 turns loosely cpid. to wavemagnet		Modulated	BC 1400 Kc.	C3, C2	Align detector and antenna stage.
4 (a)	Pin 1 (grid) on 6AU6 limiter.	.05 Mfd.	10.7 Mc. Unmodulated 100	FM 100	Adj. Primary of Discriminator T4	Align primary of discriminator for maximum reading.
5 (b)	Pin 1 (grid) on 6AU6 limiter.	.05 Mfd.	10.7 Mc. Unmodulated 100	FM 100	Adj. Secondary of Discriminator T4	Adjust secondary of discriminator for zero reading.
6 (c)	Pin 1 (grid) on 6BA6 2nd. I F.	.05 Mfd.	10.7 Mc. Unmodulated 100	FM 100	Adj. Pri. and Sec. T3A	Align 3rd. IF transformer for maximum reading.
7 (c)	Pin 1 (grid) on 6BA6 1st. IF.	.05 Mfd.	10.7 Mc. Unmodulated 100	FM 100	Adj. Pri. and Sec. T2A	Align 2nd IF transformer for maximum reading.
8 (c)	Pin 2 (grid) on 12AT7 or 12AV7 converter tube socket	.05 Mfd.	10.7 Mc. Unmodulated 100	FM 100	Adj. Pri. and Sec. T1A	Align 1st. IF transformer for maximum reading.
9 (c)	Antenna Post FM (Remove line ant.)	270 ohms	98 Mc. Unmodulated 100	FM 100	L7 Osc. Coil Slug.	Set Oscillator to dial scale.
10 (c) (d)		270 ohms	98 Mc. Unmodulated 100	FM 100	L4 Det. Coil Slug	Align det. stage to maximum reading.

IMPORTANT

Alignment of this chassis will in most cases be unnecessary unless an IF or RF transformer is replaced or the adjustments have been tampered with.

NOTE: If 12AT7 is replaced by a 12AV7 or vice versa the RF portion of this receiver must be realigned.

Correct alignment can only be made if the following procedure is followed:

A vacuum tube voltmeter with an isolation resistor of 2,000-000 ohms in series with the hot lead will serve for FM adjustments. This lead should be shielded.

An AC output meter connected across the primary or secondary of the output transformer will be satisfactory for all AM adjustments.

The signal generator output should be kept just high enough to get an indication on the meter.

In the event the receiver oscillates during phono operation, adjust C16 4-80 mmf. capacitor to a point at which the oscillation ceases.

This position of no oscillation will sometimes vary with different cartridges, and in this case readjustment of C16 must be made.

(a) Vacuum Tube Voltmeter Lug 7 on discriminator transformer to chassis (Half discriminator load).

(b) Vacuum Tube Voltmeter Lug 5 on discriminator transformer to chassis (Full discriminator load).

(c) Vacuum Tube Voltmeter from Lin-iter Grid to Chassis.

(d) Loosen Slugs by applying a hot iron to the cement.

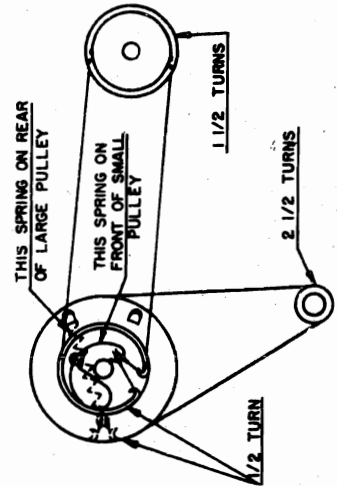

DIAL CORD DRIVE

MODELS J1083E, J1083EZ,
J1086, J1086R, J1086RZ,
J1087, J1087Z, Ch. 10H20Z

PARTS LIST

PART NO.	DIAG. NO.	DESCRIPTION	PRICE	PART NO.	DIAG. NO.	DESCRIPTION	PRICE
<u>MISCELLANEOUS (CONT'D.)</u>				<u>CABINET PARTS J1083EZ</u>			
93-965		Rubber Washer (used on S-13800)	.02	J1083EZ is the same as J1083E except the following:			
93-1039		Gang Cond. Mtg. Cup Washer (2 used)	.01	S-18560		Record changer slide assembly (2 used)	
95-1252	T5	Speaker Output Trans.	2.50	S-18563		Record changer mtg. frame.	
95-1253	T6	Pwr. Trans.	12.50	14-1364		Console Combination Cabinet	
113-43		6-32 x 5/16 Hex Hd. S.T. (used on S-17258)	.03	70-178		#8 x 1" R.H.W.S Steel Shipping bolt for changer (2 used)	
114-39		8-32 x 1/4 lg. x 1/4 Hex Hd. (2 used on S-17258 & 4 used on 57-1736)	.60	72-102		#6 x 1/2" Phillips F.H.W.S. Steel black zinc (6 used)	
126-618		Miniature Tube Shield	.02	72-103		#10 x 2 1/2" F.H.W.S. Steel black zinc (2 used)	
148-122		Tuner Arm	.20	112-846		#8 x 3/8" Phillips Pan Hd. Self tapping screw type "A" Cad. or Zinc (5 used)	
149-95		Iron Core & Spring (2 used)	.30	152-208		Record Changer stop block.	
S-17257		Speaker Cable & Eyelet Assem.	.35	203-422		Phono Caution Tag.	
<u>CABINET PARTS J1083E</u>				<u>CABINET PARTS J1086</u>			
2-260		Cabinet Back (Phono Section)	3.25	Model J1086 is the same as J1086R except the following:			
14-1343		Cabinet for J1083E-Console Combination Model	---	2-267		Cabinet Back (Phono & Record Storage Section)	2.25
16-730		Packing Carton	---	14-1349		Cabinet for J1086 Console Combination Model	---
17-121		Cable Clamp	.20	<u>CABINET PARTS J1086R</u>			
19-9		Cable Clip	.03	Model J1086R is the same as J1083E except the following:			
19-169		Record Changer Mtg. Clip (2 used)	.07	2-266		Cabinet Back (Phono & Record Storage Section)	2.25
36-47		Record Changer Handle	1.15	14-1349R		Cabinet for J1086R-Console Combination Model	---
46-876		Tuning Control Knob	.15	16-737		Packing Carton	---
46-899		Band Switch Knob	.15	57-1284		Strike Plate (2 used)	.05
49-703	SP1	12" PM Speaker	10.00	156-35		Bullet Catch (2 used)	.05
57-1270		ZC1216F Cone & Voice Coil	4.60	166-57		Tack Bumper (4 used)	.03
57-1481		Strike Plate (2 used)	.05	<u>CABINET PARTS J1086RZ</u>			
57-1666		Escutcheon Clamping Plate (4 used)	.02	J1086RZ is the same as J1086R and uses the same cabinet parts as J1083Z, except:			
57-1736		Radio Dial Esc.	4.50	14-1366R		Console Combination Cabinet	
70-3		Chassis Bottom Plate	.60	<u>CABINET PARTS J1087</u>			
70-86		#5 x 1/2" R.H.W.S. Steel N.P. (used on 19-9 & 2 used 83-1220)	.85C	Model J1087 is the same as J1083E except the following:			
78-891		#6 x 5/8" Washer Hd. Wood Screw St. Br. (8 used to Mt. Back & 1 used on 17-121)	.60C	2-262		Cabinet Back (Phono & Record Storage Section)	2.00
80-604		Pilot Light Socket & Wire	.60	14-1345		Cabinet for J1087 - Console Combination Model	---
80-830		Hinge Spring (2 used)	.15	16-731		Packing Carton	---
80-865		Record Changer Mtg. Spring (4 used)	.03	<u>CABINET PARTS J1087Z</u>			
80-868		Ground Spring	.05	J1087Z is the same as J1087 and uses the same cabinet parts as J1083Z, except:			
83-728		Ground Spring	.15	14-1365		Console Combination Cabinet	
83-1220		Chassis Mtg. Spring (2 used)	.02	<u>RADIOORGAN ESCUTCHEON ASSEM.</u>			
90-367		Pilot Light Socket Mtg. Strip.	.03	76-444		Radiorgan Knob Shaft	.04
93-168		Pilot Light Tube	.01	114-297		#6 x 1/4" Hex Hd. S.T. (2 used on S-17252 & S-17253)	.01
93-965		Rubber Shoulder Washer (4 used on Chassis Mtg.)	.07	S-17246		Radiorgan Knob & Eyelet Assem. (Treble)	.20
100-67		Rubber Washer (4 used on chassis Mtg.)	.02	S-17247		Radiorgan Knob & Eyelet Assem. (Voice)	.20
114-39		Pilot Light Bulb	.11	S-17248		Radiorgan Knob & Eyelet Assem. (Alto)	.20
114-353		#8 x 1/4" Hex Hd. S.T. (4 used on 57-1736)	.01	S-17249		Radiorgan Knob & Eyelet Assem. (Bass)	.20
114-354		#6 x 1/4" Hex Hd. S.T. (6 used on Esc. Mtg.)	.02	S-17250		Radiorgan Knob & Eyelet Assem. (Lo Bass)	.20
156-33		Chassis Mtg. Screw (4 used)	.07	S-17251		Radiorgan Knob & Eyelet Assem. (Normal)	.20
159-50		Bullet Catch (2 used)	.05	S-17252		Radiorgan Esc. & Knob Assem. (R.H.)	1.55
165-13		Plug Button (2 used)	.01	S-17253		Radiorgan Esc. & Knob Assem. (L.H.)	1.55
166-57		Metal Glide (4 used)	.02	S-17255		Radiorgan Cable Assem.	2.60
171-7		Tack Bumper (4 used)	.03				
188-54		Pilot Light Lens	.20				
192-138		Knob Clamping Ring (46-876)	.02				
202-697		Dial Glass	.50				
202-894		F.M. Instruction Book	.10				
S-14029		Radio-Phono Instruction Book	.30				
S-15780		Variable Speed Record Changer	---				
S-16419		Cobra Tone Arm Cartridge	3.50				
S-17060		Record Adapter Plug & Envelope Assem.	.60				
S-17167		Wire & Terminal Assem.	.10				
S-17328	L2	Vol. Control Knob Assem.	.25				
S-17917	L1	Loop Loading Coil Assembly	.65				
S-18215		Low Impedance Loop, Clip & Strip Assem.	.75				
		Record Changer Mtg. Frame Assem.	2.00				

MODELS J1083E, J1083EZ,
J1086, J1086R, J1086RZ,
J1087, J1087Z, Ch. 10H20Z

COILS & CHOKES

20-337	L11	R.F. Choke Coil (10 used)		.20
95-1150	T2A, 3A	2nd. & 3rd. I.F. Trans. (F.M.)		1.50
95-1153	T4	Discriminator Trans.		1.50
95-1201	T1A	1st. I.F. Trans. (F.M.)		1.50
95-1248	T1B	1st. I.F. Trans. (B.C.)		1.60
95-1249	T2B	2nd. I.F. Trans. (B.C.)		1.60
95-1254	T3B	3rd. I.F. Trans. (B.C.)		1.60
S-12603	L8	Phono Osc. Coil Assem.		.75
S-13800	L9	Tone Choke Assem.		.60
S-13997	L10	Filament Choke Coil Assem.		.40
S-15691	L7	F.M. Osc. Coil Assem.		.40
S-15743	L4	F.M. Det. Coil Assem.		.65
S-16344	L5	Broadcast Det. Coil Assem.		.60
S-16345	L6	Broadcast Osc. Coil Assem.		.60
S-16408	L3	Ant. Choke Coil Assem.		.25

CONDENSERS

22-3	C13	.01 Mfd. Ceramic (9 used)	500V	.26
22-5	C22	110 Mmfd. Ceramic (or 22-1669) (4 used)	500V	.26
22-171	C10	.05 Mfd.	600V	.33
22-178	C33	.05 Mfd.	200V	.20
22-348	C32	.001 Mfd. (Molded)	500V	.26
22-492	C14	.002 Mfd.	600V	.20
22-829	C5	.05 Mfd. (2 used)	200V	.20
22-830	C23	.02 Mfd. (2 used)	600V	.20
22-1203	C28	.001 Mfd. (2 used)	600V	.20
22-1220	C17	.002 Mfd. (2 used)	600V	.20
22-1256	C27	75 Mmfd. (molded)	500V	.20
22-1367	C12	50 Mmfd. Ceramic	500V	.33
22-1506	C9	22 Mmfd. Ceramic (2 used)	500V	.33
22-1531	C24	.2 Mfd.	200V	.20
22-1612	C29AB			
	C29BB	Elect. 40 Mfd.	450V	3.50
22-1645	C25	330 Mmfd. (molded)	500V	.20
22-1668	C21	200 Mmfd. Ceramic	500V	.20
22-1676	C7	.001 Mfd. Ceramic (4 used)	500V	.40
22-1745	C18	250 Mmfd. Ceramic	500V	.20
22-1761	C31	50 Mmfd. Ceramic	500V	.20
22-1762	C11	1 Mmfd. Ceramic	500V	.20
22-1782	C19	.0047 Mfd. (molded)	600V	.26
22-1802	C26	.002 Mfd.	1600V	.26
22-1863	C15	10 Mmfd. Ceramic	500V	.25
22-1887	C20	25 Mmfd. Ceramic	500V	.26
22-2104	C1	Three Section Variable		3.80
22-2140	C6	15 Mmfd. Ceramic (2 used)	500V	.20
22-2243	C30AB			
	C30BB	Elect. 20 Mfd. - 350V x 40 Mfd.	450V	3.00
22-2251	C16	Trimmer Cond.		.35
22-2276	C34	Dual Ceramic .01 Mfd. - .01 Mfd.	500V	.50

DIAL ASSEMBLY

78-898		Dial Light Socket & Wire		.35
80-69		Dial Cord Spring		.05
80-746		Pulley Retaining Spring		.02
80-747		Dial Cord Spring		.10
100-67	PL1	Dial Light Bulb		.11
188-30		Retaining Ring (used on S-17155)		.02
S-17155		Tuning Shaft & Pulley Assem.		.35
S-17157		Pointer & Pulley Assem.		.55
S-17158		Dial Cord & Eyelet Assem. (Long)		.07
S-17159		Dial Cord & Eyelet Assem. (Short)		.06
S-17258		Dial Scale & Brkt. Assem.	1.50	
S-17261		Brkt. & Pulley Bushing Assem.		.30

RESISTORS

63-966	R12	4700 ohm 2W 20% Carb. Res.		.19
63-1193	R39	5600 ohm 2W 10% Ins. Res.		
		(used only when 12AV7 is used or 63-2064)		.36
63-1452	R26	270 ohm W.W. 2W 10% Ins. Res.		.33
63-1716	R4	22 ohm 1/2W 20% (or 63-2446 if req.)		
		Ins. Res.		.21
63-1722	R16	33 ohm 1/2W 10% Ins. Res.		.21
63-1723	R2	33 ohm 1/2W 20% Ins. Res.		.21
63-1744	R17	100 ohm 1/2W 20% Ins. Res.		.21
63-1758	R3	220 ohm 1/2W 20% Ins. Res. (3 used)		.21
63-1764	R24	330 ohm 1/2W 10% Ins. Res.		.21
63-1771	R8	470 ohm 1/2W 10% Ins. Res.		.21
63-1772	R7	470 ohm 1/2W 20% Ins. Res.		.21
63-1778	R20	680 ohm 1/2W 20% Ins. Res.		.21
63-1786	R9	1000 ohm 1/2W 20% Ins. Res.		
		(used only when 12AT7 is used)		.21
63-1793	R14	1500 ohm 1/2W 20% Ins. Res.		.21
63-1799	R32	2200 ohm 1/2W 10% Ins. Res.		.21
63-1813	R19	4700 ohm 1/2W		.21
		Ins. Res.		.21
63-1820	R36	6800 ohm 1/2W 10% Ins. Res.		.21
63-1827	R6	10K ohm 1/2W 10% Ins. Res. (2 used)		.21
63-1842	R22	22K ohm 1/2W 20% Ins. Res. (2 used)		.21
63-1845	R23	27K ohm 1/2W 10% Ins. Res.		.21
63-1848	R30	33K ohm 1/2W 10% Ins. Res.		.21
63-1849	R13	33K ohm 1/2W 20% Ins. Res.		.21
63-1856	R10	47K ohm 1/2W 20% Ins. Res.		.21
63-1862	R38	68K ohm 1/2W		.21
		Ins. Res.		.21
63-1869	R29	100K ohm 1/2W 10% Ins. Res.		.21
63-1870	R21	100K ohm 1/2W 20% Ins. Res.		.21
63-1876	R27	150K ohm 1/2W 10% Ins. Res. (2 used)		.21
63-1884	R11	220K ohm 1/2W 20% Ins. Res. (3 used)		.21
63-1890	R25	330K ohm 1/2W 10% Ins. Res. (2 used)		.21
63-1897	R33	470K ohm 1/2W 10% Ins. Res.		.21
63-1898	R34	470K ohm 1/2W 20% Ins. Res.		.21
63-1912	R1	1 Megohm 1/2W 20% Ins. Res.		.21
63-1926	R5	2.2 " 1/2W 20% Ins. Res. (4 used)		.21
63-1940	R28	4.7 " 1/2W 20% Ins. Res.		.21
63-2091	R18	820 ohm W.W. 1/2W 20% Ins. Res.		.21
63-2138	R37AB	Candohm		1.10
	R37BB			
63-2139	R31	Volume Control & Switch		1.81
63-2141	R15	22K ohm 2W 20% Ins. Res.		.33
63-2142	R35	130 ohm 5W 10% Zipohm		.43

MISCELLANEOUS

11-85		Line Cord & Plug (6 ft. lg.)		.65
19-212		Transformer Mtg. Clip (2 used on 95-1252)		.04
54-306		Speed Nut (used on S-13800)		.06
57-1736		Chassis Bottom Plate		.60
78-580		Nine Contact Socket		.22
78-644		Phono Connector Socket		.12
78-755		Octal Tube Socket (3 used)		.18
78-807		Miniature Tube Socket		.15
78-869		Miniature Tube Socket		.20
78-870		Miniature Tube Socket (3 used)		.15
78-871		Miniature Tube Socket		.15
78-896		Three Contact Socket		.10
78-897		Two Contact Socket		.10
78-903		Miniature Tube Socket (9 contact)		.30
80-780		Iron Core Tension Spring (3 used)		.05
80-781		Tuner Arm Tension Spring		.06
80-865		Ground Spring		.05
80-868		Grounding Spring		.15
85-505	S2	S.P.D.T. Switch (Ant.)		.90
85-508	S1	Band Switch		3.25

Prices shown are suggested list prices and are subject to change without notice.

PARTS LIST

S-19007 L1 Wavemagnet Assembly (K510 & K510Y)
 S-19024 Wavemagnet Assembly (K510W)

Prices shown are suggested list prices and are subject to change without notice.

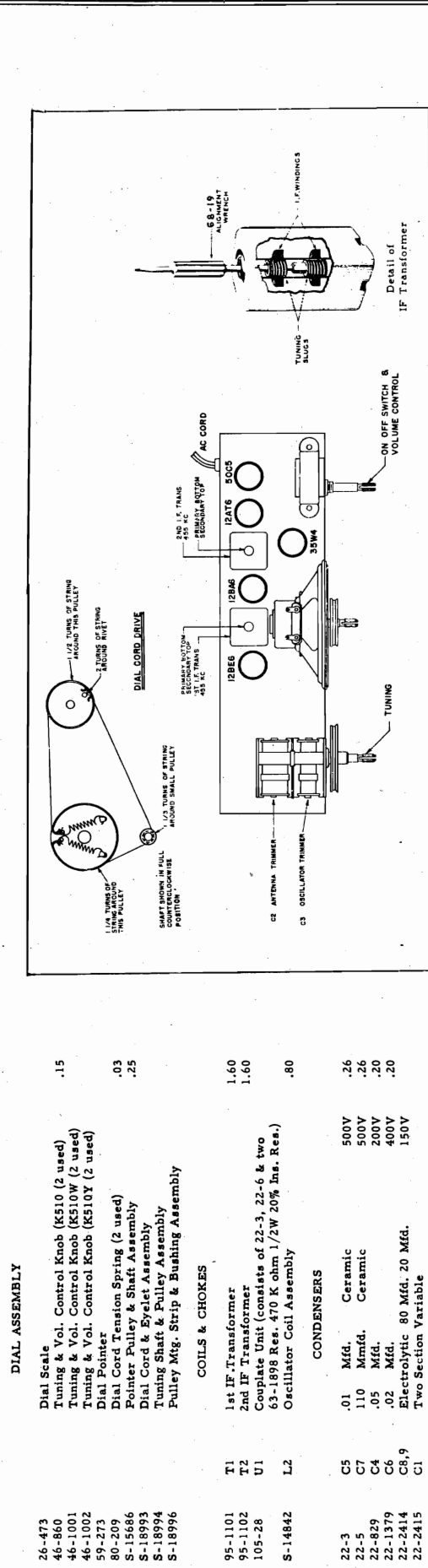

TUBE, TRIMMER LOCATION, DIAL CABLE DRAWING AND DETAILED VIEW OF I.F. TRANSFORMERS.

The I.F. transformers incorporated in this receiver are of the new permeability tuned type. The advantage of an I.F. transformer of this type is its extreme stability under various humidity and temperature conditions. The upper coil is the secondary and the lower the primary. When adjusting these I.F. transformers the tuning wrench 68-19 can be inserted into the top slug, rotated until maximum output is obtained and then dropped down to the lower slug and the same operation repeated. The tuning wrench is so designed that turning one slug does not affect the adjustment of the other.

ALIGNMENT PROCEDURE

OPERATION	CONNECT TO OSCILLATOR	DUMMY ANTENNA	INPUT SIG. FREQUENCY	SET DIAL AT	TRIMMERS	PURPOSE
1	Converter Grid	.5 Mfd.	455 Kc.	600 Kc.	L3, L4, L5, L6	Align I.F. for maximum output
2	One Turn Loop Coupled Loosely to Wave Magnet	---	1600 Kc.	1600 Kc.	C3	Set Oscillator to Dial Scale.
3	Wave Magnet	---	1400 Kc.	1400 Kc.	C2	Align Antenna Stage

PART NO.	DIAG. NO.	DESCRIPTION	PRICE
DIAL ASSEMBLY			
26-473		Dial Scale	.15
46-860		Tuning & Vol. Control Knob (K510 (2 used))	
46-1001		Tuning & Vol. Control Knob (K510W (2 used))	
46-1002		Tuning & Vol. Control Knob (K510Y (2 used))	
59-273		Dial Pointer	.03
80-209		Dial Cord Tension Spring (2 used)	.25
S-15686		Pointer Pulley & Shaft Assembly	
S-18993		Dial Cord & Eyelet Assembly	
S-18994		Tuning Shaft & Pulley Assembly	
S-18996		Pulley Mtg. Strip & Bushing Assembly	
COILS & CHOKES			
95-1101	T1	1st IF Transformer	1.60
95-1102	T2	2nd IF Transformer	1.60
105-28	U1	Complete Unit (consists of 22-3, 22-6 & two 63-1898 Res. 470 K ohm 1/2W 20% Ins. Res.)	.80
S-14842	L2	Oscillator Coil Assembly	
CONDENSERS			
22-3	C5	Mfd. Ceramic 500V	.26
22-5	C7	Mfd. Ceramic 500V	.26
22-829	C4	Mfd. Ceramic 200V	.20
22-1379	C6	Mfd. Ceramic 400V	.20
22-2414	C8,9	Electrolytic 80 Mfd. 20 Mfd.	
22-2415	C1	Two Section Variable	
RESISTORS			
63-686	R7	150 ohm 1/2W WW 10% Ins. Res.	.21
63-1450	R9	22 ohm 1W WW 20% Ins. Res.	.24
14-1444	R8	1 K ohm 1W 20% Ins. Res.	.24
63-1737	R1	68 ohm 1/2W 20% Ins. Res.	.21
63-1842	R4	22 K ohm 1/2W 20% Ins. Res.	.21
63-1926	R2	2.2 Megohm 1/2W 20% Ins. Res.	.21
63-1940	R5	4.7 Megohm 1/2W 20% Ins. Res.	.21
63-2806	R3	Vol. Control & Switch	
MISCELLANEOUS			
11-85		Line Cord & Plug	.65
14-1444		Plastic Cabinet K510	
14-1446		Plastic Cabinet K510W	
14-1447		Plastic Cabinet K510Y	
16-810		Packing Carton	
49-721	SP1	4" PM Speaker	.01
54-159		3/8-32x5/16" Nut (for 63-2806)	.01
54-267		#6-32x5/16" Nut (for 95-1101, 95-1102)	.01
57-1833		Emblem Plate	
64-251		Braas Eyelet (used on S-18996)	.01
78-806		Miniature Tube Socket (2 used)	.15
78-807		Miniature Tube Socket (3 used)	.15
83-1640		Support Strip (used on 95-1101, 95-1102)	.03
93-415		#6 Shakeproof Lockwasher (22-2415)	.01
94-334		Bushing (Mtg. 22-2415)	.01
95-1308		Output Transformer	2.25
110-139	T3	Grille Cloth	.15
112-697		8-32x1/16 S.T. Screw (2 used on chassis mtg.)	.02
114-39		6-32x1/4 Hex Hd. S.T. Screw	.01
114-67		6-32x7/16x1/4 Hex Hd. Screw (3 used on Gang Mtg.)	.01
114-253		6-20x3/8x1/4 Hex Hd. S.T. Screw (2 used on Spkr. Mtg.)	.01
125-81		Strain Relief Grommet (Male)	.05
125-82		Strain Relief Grommet (Female)	.05
159-69		Trimount Stud (4 used Wavemagnet Mtg.)	.01
188-32		Retaining Ring (for S-18994)	.02
188-149		Retaining Ring (for S-15686)	.02
202-925		Instruction Book	

MODELS K510, K510W,
K510Y, Ch. 5K02

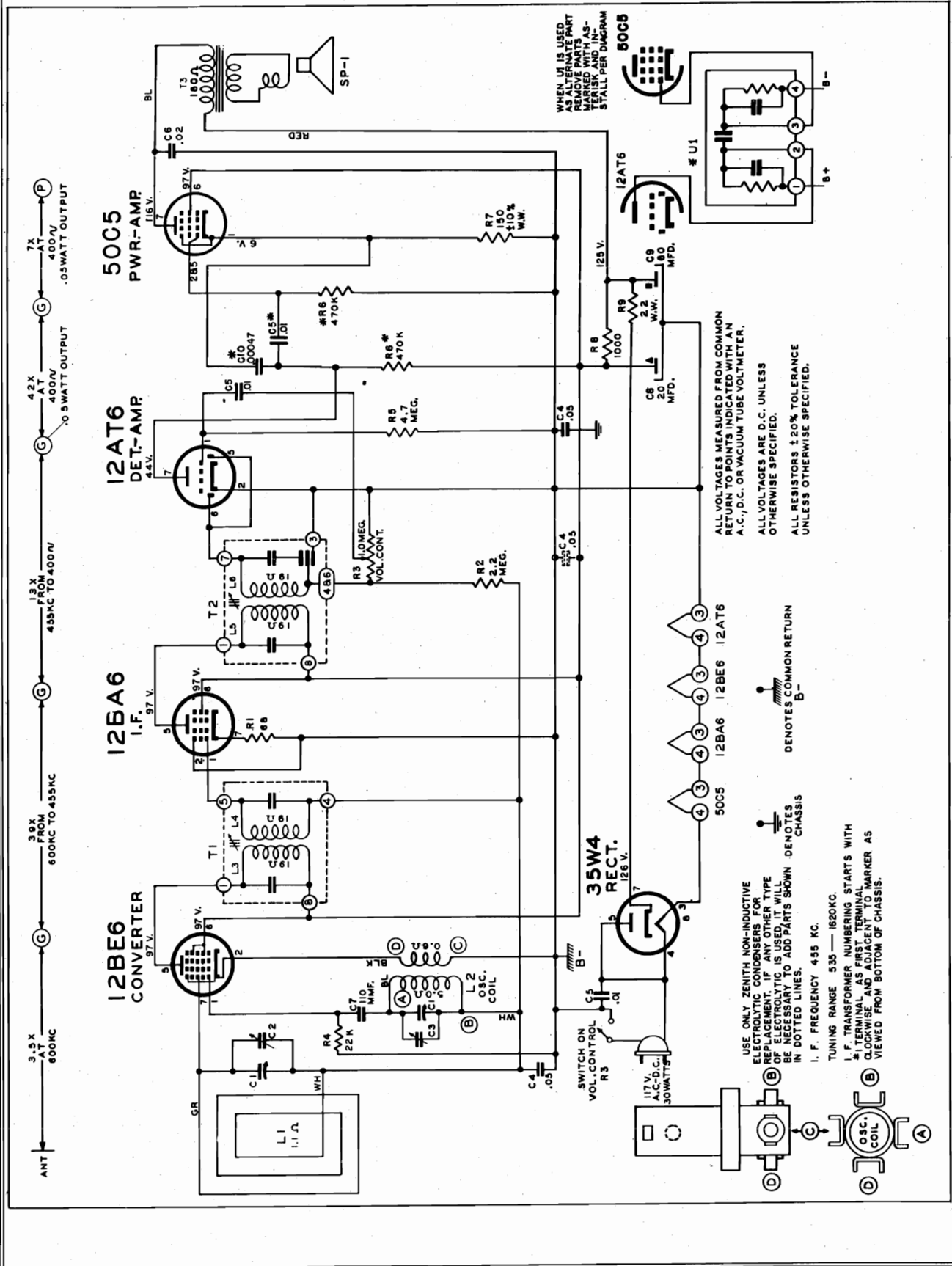

The I.F. transformers incorporated in this receiver are of the new permeability tuned type. The advantage of an I.F. transformer of this type is its extreme stability under various humidity and temperature conditions. The upper coil is the secondary and the lower the primary. When adjusting these I.F. transformers the tuning wrench 68-19 can be inserted into the top slug, rotated until maximum output is obtained and then dropped down to the lower slug and the same operation repeated. The tuning wrench is so designed that turning one slug does not affect the adjustment of the other.

In the event the receiver oscillates during phono operation, adjust C16 4-80 mmf. capacitor to a point at which the oscillation ceases.

This position of no oscillation will sometimes vary with different cartridges, and in this case readjustment of C16 must be made.

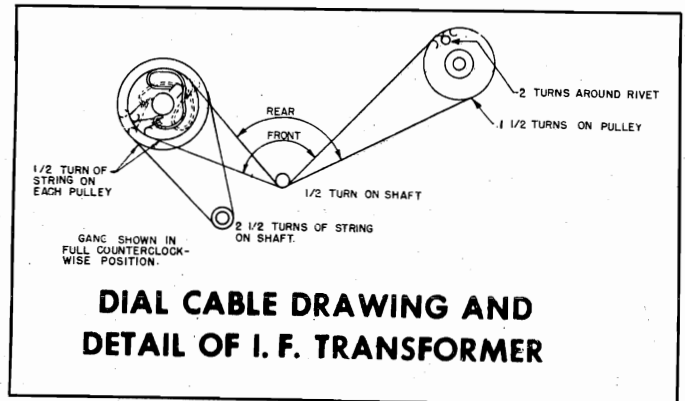

**DIAL CABLE DRAWING AND
DETAIL OF I. F. TRANSFORMER**

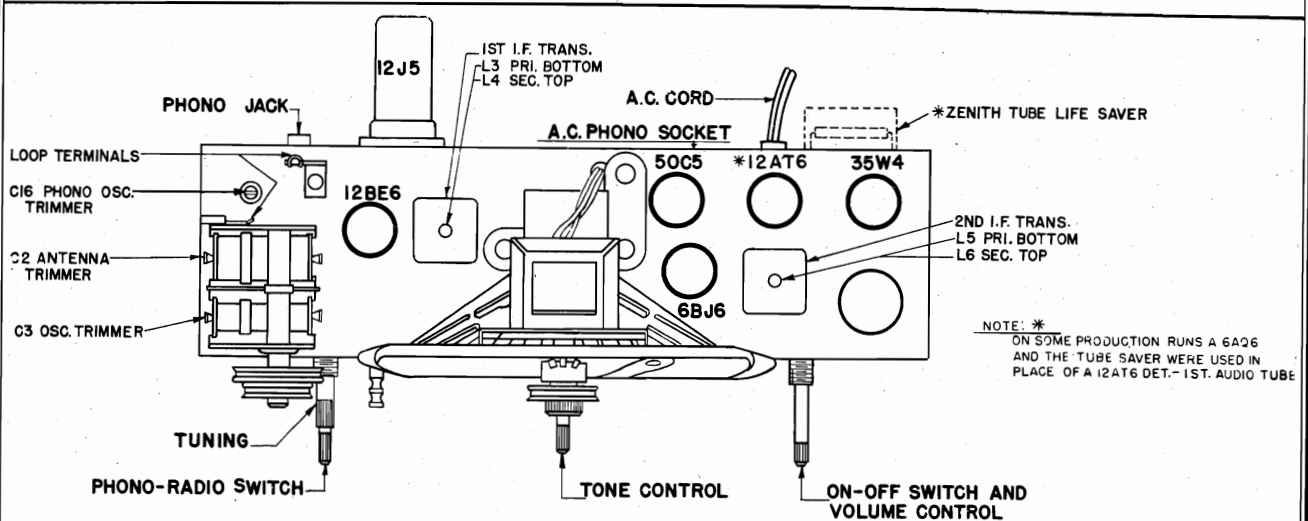

TUBE AND TRIMMER LOCATION

ALIGNMENT PROCEDURE

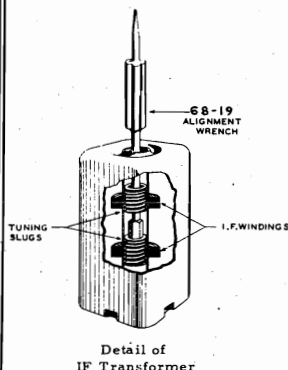

OPERATION	CONNECT OSCILLATOR TO	DUMMY ANTENNA	INPUT SIG. FREQUENCY	SET DIAL AT	TRIMMERS	PURPOSE
1	Converter Grid	.5 Mfd.	455 Kc.	600 Kc.	L3, 4, 5, 6	For I. F. Alignment
2	One Turn Loop Coupled Loosely to Wave Magnet	--	1600 Kc.	1600 Kc.	C-3	Set Oscillator to Dial Scale.
3		--	1400 Kc.	1400 Kc.	C-2	Align Antenna Stage

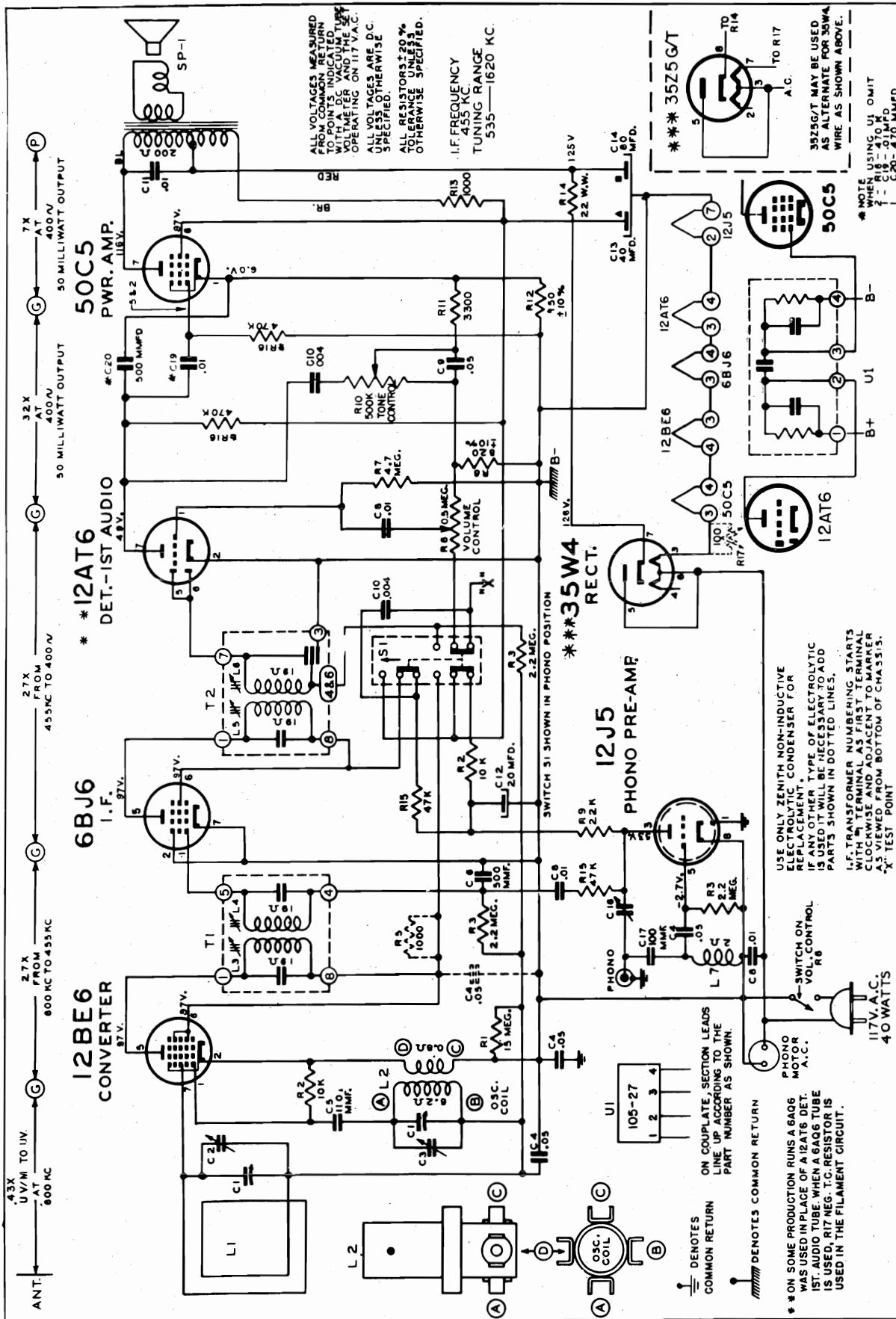

PARTS LIST

MODEL K666R CHASSIS 6K02

Part No.	Diag. No.	Description	Price	Part No.	Diag. No.	Description	Price
11-85		Line cord & plug	.65	125-17		Rubber grommet (3 ea. speaker & gang)	.03
22-3	C8,19	.01 Mfd. ceramic disc (3 used) 500V	.26			Rubber grommet (2 used on 78-709)	.03
22-4	C10	.004 Mfd. ceramic disc (2 used) 500V	.26	125-26		Strain relief grommet (used with 11-85)	.05
22-5	C5	110. Mmfd. ceramic disc (or 22-162 100 Mmfd. mica)	500V .20	125-82		Strain relief grommet (used with 11-85)	.05
22-178	C9	.05 Mfd.	200V .20	166-65		Rubber bumper (gang)	.02
22-829	C4	.05 Mfd. (3 used)	200V .20	188-34		Retaining ring (63-2269)	.02
22-854	C6,20	.0005 Mfd.	600V .20	188-60		Retaining ring (76-629)	.02
22-1182	C11	.01 Mfd.	400V .20	S-12603	L7	Phono oscillator coil assem.	.75
22-2242	C16	Trimmer	.40	S-13799	L2	Oscillator coil assem.	.75
22-2272	C12,13,14	Electrolytic 20/150V 40/150V 80/150V	2.75	S-19056		Dial cord assem. (short)	.06
22-2361	C17	100 Mmfd. film on mica molded 500V	.25	S-19200		Dial cord assem. (long)	
22-2427	C1	Two Gang variable		S-19201		Pulley & bushing assem.	
24-614		Resistor cover		S-19203		Bracket & lug (tone control)	
44-25		Phono jack	.20				
49-725	SP1	7 $\frac{1}{2}$ " PM speaker					
		ZC7512G cone & voice coil	2.63				
54-139		3/8-32 x9/16 palnut (to mt. 85-512, 63-2270)	.01				
54-140		3/8-32x9/16x3/32 hex nut (2 to mt. S-19203)	.03	14-1468		Plastic cabinet, top section	
54-269		#8-32x11/32 palnut(to mt. 63-2269)	.01	14-1469		Plastic cabinet, bottom section	
54-271		6-32x1/4 palnut (to mt. IF trans.)	.01	16-829		Packing carton	
63-1450	R14	22 ohm 1W WW	20% Ins.Res. .24	17-116		Wavemagnet retaining clamp (2 used)	.01
63-1574	R13	1K ohm 1W	20% Ins.Res. .24	19-169		Record changer mtg. clip (3 used)	.07
63-1782	R8	820 ohm $\frac{1}{2}$ W	10% Ins.Res. .21	24-606		Chassis cover	
63-1786	R5	1000 ohm $\frac{1}{2}$ W	Ins.Res. .21	26-477		Dial Scale (Part of S-19170)	
63-1807	R11	3300 ohm $\frac{1}{2}$ W	20% Ins.Res. .21	40-93		Cabinet cover hinge (2 used)	.50
63-1828	R2	10K ohm $\frac{1}{2}$ W(2 used)	20% Ins.Res. .21	40-94		Cover support hinge	.75
63-1842	R9	22Kohm $\frac{1}{2}$ W	20% Ins.Res. .21	43-213		Housing (part of S-19173)	
63-1856	R15	47K ohm $\frac{1}{2}$ W(2 used)	20% Ins.Res. .21	46-1019		Tone control knob	
63-1926	R3	2.2 Megohm $\frac{1}{2}$ W (3 used)	20% Ins.Res. .21	46-1020		Phono-radio knob	
63-1940	R7	4.7 Megohm $\frac{1}{2}$ W	20% Ins.Res. .21	46-1105		Tuning control knob	
63-1961	R1	15 Megohm $\frac{1}{2}$ W	20% Ins.Res. .21	54-129		Speed nut (7 used)	.01
63-1977	R12	150 ohm 1W	10% Ins.Res. .24	57-1798		Record changer trim strip	.50
63-2269	R10	Tone Control	1.20	59-279		Dial pointer	
63-2270	R6	Volume control & switch	1.81	80-830		Record changer mtg. spring (3 used)	.03
63-2797	R17	100 ohm special resistor	.85	80-881		Hinge tension spring	.25
64-2		Rivet (2- 78-709)	.01	83-2045		Felt strip (2 used)	
64-5		Rivet (2 78-810, 2 78-351)	.01	93-1094		Steel washer (4 used on 112-838)	.02
64-6		Rivet (2 44-25, 2 78-910)	.01	94-753		Bushing (2 to mt. 57-1798)	.15
64-7		Rivet (2 78-801)	.01	94-795		Spacer bushing (2 to mt. S-19173)	
64-183		Rivet (2 ea. 78-806, 807, 863)	.01	102-750		Decal. transfer (radio-phon)	.05
69-33		#8-32x1/2 rd.hd. mach. screw (2 to mt. S-19203)	.01	112-773		6-20x3/8 phill pan hd. s.t. screw (2 used on 17-116, 4 used on hinge)	.03
76-629		Tuning control shaft	.40	112-820		#8x1/2 phill flat hd s.t. screw (4 used on hinge)	.03
78-351		Two contact socket	.07	112-828		6-20x7/8 phill flat hd. s.t. screw (2 used on 57-1798)	.03
78-709		Octal tube socket	.20	112-838		8-18x1/2 phill pan hd. s.t. screw (4 used on hinge)	.05
78-801		Octal tube socket (35Z5GT when used)	.15	112-840		#8x15/16 R.H. s.t. screw (red finish) (S-14044)	.03
78-806		Min. tube socket	.15	112-871		#6x3/8 special s.t. screw (4 used on 24-606)	
78-807		Min. tube socket (2 used)	.15	114-42		Chassis mtg. screw (4 used)	.02
78-810		Min. tube socket (35W4 when used)	.15	114-399		#8-18x3/4 hex hd. s.t. screw (2 used on S-19173)	
78-863		Min. tube socket	.20	125-62		Rubber grommet (1 used on S-14044)	.02
78-910		Electrolytic socket	.05	125-86		Rubber grommet (2 used on S-19173)	
80-747		Dial cord tension spring	.10	188-54		Knob retaining ring	.02
80-921		Dial cord tension spring		196-206		Speaker gasket (part of S-19170)	.60
83-2063		Bakelite strip	.02	196-210		Housing gasket (part of S-19173)	
85-512	S1	Radio-Phono switch	1.10	202-934		Instruction book - radio-phon	
93-59		Fibre washer (to mt. 63-2269)	.02	S-14044		Variable speed record changer	
93-1043		Spring washer (to mt. 63-2269)	.06	S-15780		Cobra cartridge	3.50
93-1127		Fibre washer (2 to mt. 78-709)		S-19169	L1	Wavemagnet assem.	
94-295		Gang & speaker mtg. bushing (6 used)	.04	S-19170		Dial scale & gasket (26-477 & 196-206)	
95-1101	T1	1st. IF trans.	1.60	S-19173		Housing & gasket (43-213, 196-210)	
95-1102	T2	2nd. IF trans.	1.60	S-19174		Volume control knob assem.	
105-27	U1	Couplate unit (or 1, 22-3 - 1,22-854 - 2, 63-1898)	.80				
113-8		6-32x1/4 hex hd. mach. screw (to mt. 22-2242)	.02				
113-13		6-32x7/16 hex hd. mach. screw (to mt. 22-2427)	.02				
114-67		6-32x7/16x1/4 hex hd. mach. screw (1 to mt. 22-2427)	.01				
114-135		6-32x7/16x1/4 hex hd. s.t. screw (3 to mt. speaker)	.01				

Prices shown are suggested list prices and are subject to change without notice.

PAGE 23-34 ZENITH
MODEL L507, Ch. 5L42

Part No.	Diag. No.	Description	Price
CHASSIS PARTS			
*12-1991		Gang mtg. bracket	.15
15-51		Cable socket cap & insulator (part of S-18111)	.09
22-3	C3, 11, 19	.01 mid ceramic disc. (4 used)	
22-1662	C21	500V	.26
22-1763	C15	500V	.25
22-1765		47 mmfd mica	.20
22-1777	C4	2.2 mmfd ceramic	.20
22-1778		1.2 mmfd ceramic	.26
22-1779	C2, 29, 30, 33, 34	.1 mid molded PD	
22-1949	C18	.047 mid molded PD (2 used)	.26
22-2056	C38	560 mmfd molded mica	.30
22-2062	C28	Electrolytic 12 mmfd	1.20
22-2071	C10	3600 mmfd molded mica	.65
22-2127	C14	.022 mid PD (2 used)	.26
22-2157	C13	.001 mid molded	.26
22-2410	C31A, B, C, D	Electrolytic 60/150V, 40/150V, 20/150V, 200/10V	4.00
22-2471	C5	150 mmfd ceramic disc	.25
22-2472	C1, 7	200 mmfd ceramic disc	.25
22-2473	C17	Ceramic single section trimmer & bracket	.40
22-2474	C24A, B	Ceramic dual section trimmer & bracket	.70
22-2475	C16, 20, 27	Ceramic single section trimmer (6 used)	.30
22-2476	C9A, B, C	Three section gang	5.50
22-2485	C8	82 mmfd mica	.25
22-2486	C25	1800 mmfd mica	.60
49-734		Speaker 5 1/4 PM	6.00
54-34		6-32 x 1/2 hex nut (1 speaker mtg.)	.01
54-139		3/8-32 x 9/16 pdlnut (1 mt. vol. control)	.01
54-140		3/8-32 x 9/16 hex nut (1 mt. band switch)	.03
54-287		6-32 x 5/16 pdlnut (1 mt. ea. 212-5-95-1349-95-1350)	.01
57-1520	R12	Adapter socket cover plate	.15
63-1729	R12	47 Ohm 1/2 W Ins. 10%	.21
63-1744	R22	100 Ohm 1/2 W Ins. 20%	.21
63-1757	R9	200 Ohm 1/2 W Ins. 10%	.21
63-1771	R15	470 Ohm 1/2 W Ins. 10%	.21
63-1778	R18	680 Ohm 1/2 W (2 used) Ins. 10%	.21
63-1785	R6	1 K Ohm 1/2 W Ins. 20%	.21
63-1814	R26	4700 Ohm 1/2 W Ins. 20%	.21
63-1821	R16	6800 Ohm 1/2 W Ins. 20%	.21
63-1870	R23	100 K Ohm 1/2 W Ins. 20%	.21
63-1880	R3	180 K Ohm 1/2 W Ins. 10%	.21
63-1912	R1, 2	1 meg Ohm 1/2 W (2 used) Ins. 20%	.21
63-1933	R13	3.3 meg Ohm 1/2 W Ins. 20%	.21
63-1940	R7	4.7 meg Ohm 1/2 W Ins. 20%	.21
63-1943	R5	5.6 meg Ohm 1/2 W Ins. 10%	.21
63-1954	R11, 14	10 meg Ohm 1/2 W (2 used) Ins. 20%	.21
63-1960	R17	15 meg Ohm 1/2 W Ins. 10%	.21
63-2010	R20, 21	Two section combob	.60
63-2014	R19	140 Ohm 4WWW Ins. 10%	.38
63-2852	R10	Volume control & switch	1.81
63-3181		3300 Ohm 1/2 W Ins. 10%	.21
64-4		1/8 Dia x 1/2 rivet (2 mt. 78-844)	.01

Part No.	Diag. No.	Description	Price
CHASSIS PARTS (Cont.)			
64-7		1/8 Dia x 5/32 rivet (2 mt. 78-274)	.01
64-27		1/8 Dia x 1/8 rivet (1 mt. 83-1106-83-1257)	.01
64-88		.088 Dia x 1/8 rivet (2 mt. ea. 78-782)	.01
64-183		.088 Dia x 3/16 rivet (2 mt. ea. 78-806-78-807)	.01
64-253		Brass eyelet (2 mt. S-19999)	.01
78-274		Socket, electrolytic	.03
78-543		Socket, battery cable (part of S-18111)	.13
78-782		Socket, min. tube (2 used)	.25
78-806		Socket, min. tube	.15
78-807		Socket, min. tube (2 used)	.15
78-844		Socket, capacitor	.25
80-69		Dial cord, tension spring	.05
80-747		Dial cord, femal spring	.10
83-1106		Two lug terminal strip	.04
83-1257		Three lug term. strip	.06
83-2081		Insulating strip (for 212-5)	.02
83-2116		Antenna terminal strip	.25
85-520	S2	Power change over switch	1.00
85-528	S1	Band switch	3.10
93-827		3/8 mt. lockwasher (1 mt. 85-528)	.02
94-295		Mtg. bushing (3 mt. gang)	.04
94-334		Mtg. bushing (3 mt. speaker)	.01
93-35		Washer (1 mt. speaker)	.01
95-1345	T3	Output transformer (part of 49-734)	2.00
95-1349	T1	1st 1 F transformer	2.00
95-1350	T2	2nd 1 F transformer	2.00
105-31		Complete unit	.90
112-906		6-32 x 1/2 Phil truss hd mach screw (1 mt. speaker)	.02
113-8		No. 6-32 x 1/2 hex hd mach screw (1 mt. ea. 22-2473 & 4)	.02
113-13		No. 6-32 x 7/16 hex hd mach screw (3 mt. gang)	.02
113-33		No. 4-40 x 1/4 hex hd mach screw (2 mt. 85-520)	.02
113-37		6-32 x 1/2 hex hd mach screw (2 mt. speaker)	.03
114-297		6-32 x 1/2 hex hd self top screw (3 mt. gang, 2 mt. 83-2116, 1 mt. 57-1520)	.01
114-308		No. 6-32 x 1/4 hex hd self top screw (1 mt. 212-5)	.01
125-17		Rubber grommet (3 mt. gang - 3 mt. speaker)	.03
125-81		Strain relief grommet	.05
125-82		Strain relief grommet	.05
149-85		Iron core (S-19989-S-19990-S-19993)	.10
149-110		Iron core (S-19987-S-19988-S-19991-S-19992)	.15
166-65		Rubber bumper	.02
188-60		Retaining ring	.02
188-147		Retaining ring (for pointer shaft)	.02
199-178		Tuning shaft sleeve	.15
212-5	SE1	Selenium rectifier	1.80
S-16047	L9	Antenna loading coil	.45

Part No.	Diag. No.	Description	Price
CHASSIS PARTS (Cont.)			
S-18111		Battery cable & socket	.80
S-19981		Detector coil	2.00
S-19987	L10	Antenna coil 2-6 Mc	1.00
S-19988	L11	Antenna coil 6-18 Mc	1.00
S-19989	L12	Detector coil 2-6 Mc	.60
S-19990	L13	Detector coil 6-18 Mc	.60
S-19991	L14	Oscillator coil 2-6 Mc	1.00
S-19992	L15	Oscillator coil 6-18 Mc	1.00
S-19993	L4	Oscillator coil - broadcast	1.00
S-20001		Bracket & bushing (used with S-20001)	.30
S-19999		Pointer shaft & pulley (used with S-19999)	.30
S-20002		Dial cord & eyelet - short	.20
S-20003		Dial cord & eyelet - long	.35
S-20076	L1	Choke coil assem.	
CABINET PARTS			
14-1563		Cabinet - portable model L507Y	2.50
16-884		Packing carton	1.50
26-501		Dial scale	.35
36-79		Cabinet handle	.15
46-1172		Knob, tuning	.82
46-1173		Knob, band switch	.07
59-155		Dial pointer	.03
64-109		Brass eyelet (part of cabinet)	.03
70-196		No. 6 x 3/8 phil rd wash hd wood screw (2 mt. wavemagnet)	.02
83-1833		Dial scale rubber strip (4 used)	.01
93-132		Washer (mt. S-20051)	.01
93-1136		Slotted washer (4 mt. grille & dial scale)	.65
94-819		Antenna retaining bushing	.85
102-903		Instruction label short wave map	.65
102-904		Instruction label left distance table	.03
102-905		Instruction label right time table	.04
114-251		No. 10-32 x 5/8 hex hd mach screw (3 mt. chassis)	.25
114-399		No. 8-18 x 1/2 Hex hd self top screw (1 mt. S-200051)	.55
138-87		Metal grille	.08
156-20		Door latch upper half	.05
156-21		Door latch lower	.05
157-7		Strike fastener - male	.05
157-8		Strike fastener - female	.05
166-68		Recessed rubber bumper (4 used)	.02
188-102		Knob clamping ring (46-1172)	.60
196-222		Speaker gasket	.80
202-972		Instruction book	.20
202-974		Short wave log	1.25
S-20048		Front cover hinge - right	7.50
S-20049		Front cover hinge - left	.65
S-20051		Telescoping antenna assem.	2.00
S-20052		Volume control knob assem.	
S-20054	L2	Wavemagnet	
2909 A-B battery pack (one (1) required when used)			

Prices shown are suggested list prices and are subject to change without notice.

MODELS L401G, R,
SG, Y, Ch. 4L40

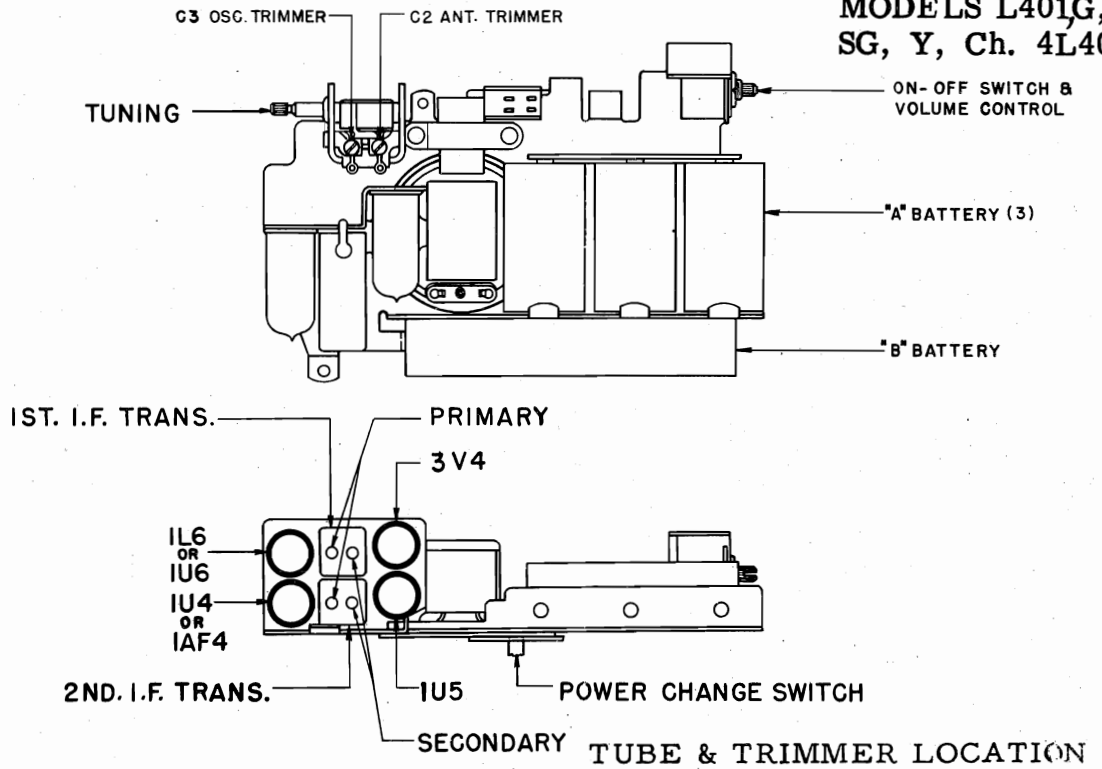

ALIGNMENT PROCEDURE

OPERATION	CONNECT OSCILLATOR TO	DUMMY ANTENNA	INPUT SIG. FREQUENCY	BAND	SET DIAL TO	TRIMMERS	PURPOSE
1	Converter Grid	.1 Mfd	455 Kc.	BC	600 Kc.	Adjust pri. and sec. trimmers for maximum output.	I.F. Alignment
2	Connect a .1 mfd capacitor across the generator output. Advance the generator output and place the capacitor approximately six inches from the receiver.		1600 Kc.	BC	1600 Kc.	Osc. Trim. C3	Set Oscillator to scale
3			1400 Kc.	BC	1400 Kc.	Ant. Trim. C2	Align Wavemagnet

Part No.	Diag. No.	Description	Price				
12-1940		Bracket (gang mtg.)	.15				
12-1941		Tube mtg. bracket	.20				
22-3	C2, 4, 7, 8	.01 Mfd. Ceramic disc. 500V (3 used)	.26				
22-4	C10	.004 mfd Ceramic disc. 500V	.26				
22-7	C5	.001 mfd Ceramic disc. 500V	.26				
22-1669	C3, 6, 9, C1A, 1B,	100 Mmfd Ceramic disc. 500V (3 used)	.20				
22-2432	1C, 1D	Gang cond.	3.50				
22-2433	C12	Electrolytic 8/70V	1.10				
22-2436	C11	.0022 mmdfd PD	.30				
49-735	SP1	Speaker 2 1/2" PM	5.50				
52-535		Shielded lead	.20				
52-630		Shielded lead	.25				
54-139		3/8-32x9/16 Palmut (1 mt. 63-1553)	.01				
63-1553	R5	Volume control & switch	1.81				
63-1762	R10, 11	300 ohm 1/2 W Ins. 5% (2 used)	.21				
63-1786	R3	1 K ohm 1/2 W Ins. 20%	.21				
63-1869	R2	100K ohm 1/2 W Ins. 20%	.21				
63-1912	R8	1 Meg ohm 1/2 W Ins. 20%	.21				
63-1933	R9	3.3 Meg ohm 1/2 W Ins. 20%	.21				
63-1940	R6, 7	4.7 Meg ohm 1/2 W Ins. 20% (2 used)	.21				
63-1947	R4	6.8 Meg ohm 1/2 W Ins. 20%	.21				
64-6		1/8 Dia. x 3/16 Rivet (2 mt. S-19267)	.01				
64-7		1/8 Dia. x 5/32 Rivet (2 mt. S-1322)	.01				
64-27		1/8 Dia. x 1/8 Rivet (1 mt. 80-922--2mt. 83-1106)	.01				
64-88		.088 Dia. x 1/8 Rivet (2 mt. ea. 78-782)	.01				
64-353		Brass eyelet (2 mt. 83-2058--2 mt. 85-525)	.01				
64-434		Brass eyelet (2 mt. 83-2058)	.01				
78-782		Socket, min. tube (4 used)	.25				
80-922		Battery tension spring (3 used)	.06				
83-1106		Two lug terminal strip	.04				
83-2058		Terminal strip	.35				
85-525		Switch (high-low)	1.85				
95-1320	T1	1st IF transformer	1.85				
95-1321	T2	2nd IF transformer	1.85				
95-1322	T3	Speaker transformer	2.00				
112-405		4-40 x 3/16 bind hd mach screw (1 mt. speaker)	.01				
112-648		4-40 x 1/4 bind hd mach screw (1 mt. speaker)	.01				
113-9		8-32 x 1/4 hex hd (1 mt. ea. 12-1940--12-1941)	.02				
113-17		6-32 x 1/4 rd hd mach screw (2 mt. 22-2432)	.02				
114-365		8-32 x 3/8 hex hd self tap screw (1 mt. S-19664)	.05				
S-19266	L1	Iron core loop assem.	1.85				
S-19267		Battery contact & strip assem.	.20				
S-19549		Battery contact & strip assem.	.35				
				S-19664		Shield & strip assem. (has clamp for loop)	.20
				S-19949	L2	Oscillator coil assem. (used with 1R5 oscillator tube)	1.25
						Cabinet Parts	
				12-1938		Swivel bracket (Part of cabinet front)	.10
				16-891		Packing carton	
				19-240		Handle swivel clip (2 used)	.10
				26-482		Dial scale L401G & SG	.60
				26-486		Dial scale L401R	.60
				26-487		Dial scale L401R	.60
				36-58		Cabinet handle L401G & SG	.95
				36-65		Cabinet handle L401Y	.95
				36-66		Cabinet handle L401R	.95
				46-1027		Knob, volume L401G, & SG	.40
				46-1061		Knob, volume L401Y	.40
				46-1062		Knob, volume L401R	.40
				46-1028		Knob, tuning L401G & SG	.40
				46-1065		Knob, tuning L401Y	.40
				46-1066		Knob, tuning L401R	.40
				57-1905		Swivel support plate (2 part of cabinet front)	.03
				57-1725		Emblem L401R, G & SG	.20
				57-1845		Emblem L401Y	.20
				64-5		1/8 Dia x 7/32 Rivet (2 mt. ea. S-19272--12-1938 S-19271)	.01
				114-248		6-20 x 5/16 hex hd self tap screw (3 mt. chassis)	.01
				188-155		Clamping ring	.04
				188-161		Knob, clamping ring (volume)	.02
				202-978		Instruction book	
				S-19271		Bracket & stud (Part of cabinet rear)	.15
				S-19272		Bracket & clip (Part of cabinet front)	.10
				S-19273		Cabinet front L401G	6.25
				S-19444		Cabinet front L401Y	7.25
				S-19445		Cabinet front L401R	7.25
				S-19933		Cabinet front L401SG	6.25
				S-19274		Cabinet rear L401G	4.25
				S-19448		Cabinet rear L401Y	5.25
				S-19449		Cabinet rear L401R	5.25
				S-19934		Cabinet rear L401SG	4.25
				S-20111		Baffle & grille cloth L401Y	.65
				S-20112		Baffle & grille cloth L401R	.65
				S-20113		Baffle & grille cloth L401G & SG	.65
						One #4 battery kit required when used	
						Consists of 3 1 1/2 Volt A battery	
						1 67 1/2 Volt B battery	
						Leather carrying case-see table (see PDM-345)	
						Prices shown are suggested list prices and are subject to change without notice.	

MODELS L401G, R,
SG, Y, Ch. 4L40

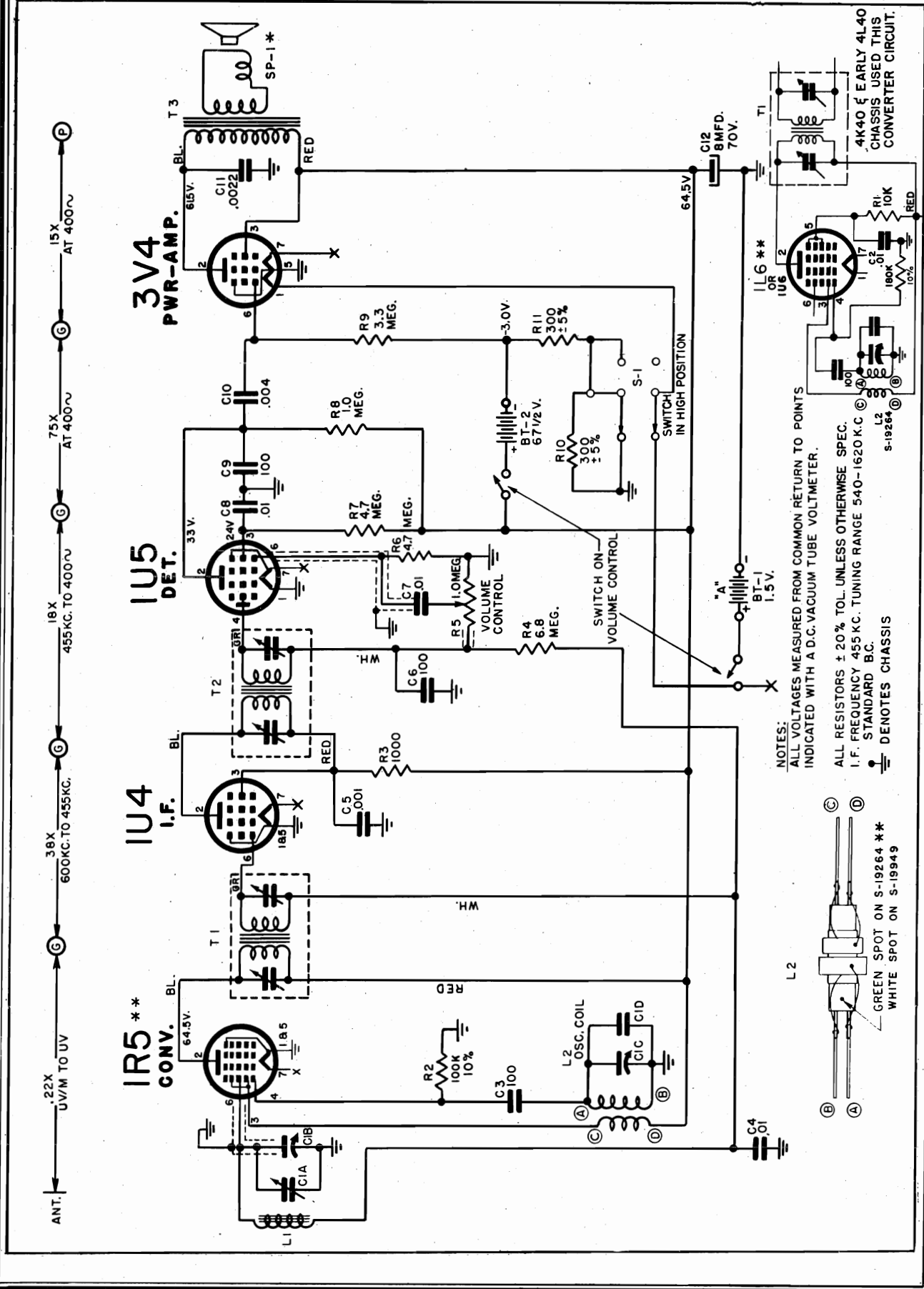

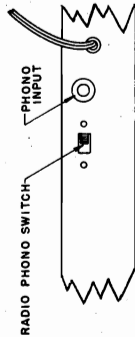
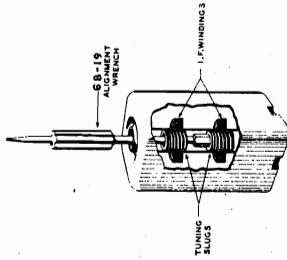

TUBE, TRIMMER LOCATION, DIAL CABLE DRAWING AND DETAILED VIEW OF I. F. TRANSFORMERS.

The I.F. transformers incorporated in this receiver are of the new permeability tuned type. The advantage of an I. F. transformer of this type is its extreme stability under various humidity and temperature conditions. The upper coil is the secondary and the lower the primary. When adjusting these I. F. transformers the tuning wrench 68-19 can be inserted into the top slug, rotated until maximum output is obtained and then dropped down to the lower slug and the same operation repeated. The tuning wrench is so designed that turning one slug does not affect the adjustment of the other.

ALIGNMENT PROCEDURE

OPERATION	CONNECT OSCILLATOR TO ANTENNA	DUMMY ANTENNA	INPUT SIG. FREQUENCY	SET DIAL AT	TRIMMERS	PURPOSE
1	Converter Grid	.5 Mfd.	455 Kc.	600 Kc.	Adjust Primary & Secondary Slug Alignment	For I.F. Alignment
2	Single Turn Loosely Coupled to Wave Magnet	---	1600 Kc.	1600 Kc.	C1F	Set Oscillator to Dial Scale
3		---	1400 Kc.	1400 Kc.	C1D	Detector Alignment
4		---	1400 Kc.	1400 Kc.	C1B	Antenna Alignment

Part No.	Description	Price
94-205	94-205	.04
95-1101	1st I.F. Trans.	1.60
95-1122	2nd I.F. Trans.	1.60
97-417	Guide Stud	.80
97-418	Guide Stud	.02
114-211	Cong. & Speaker Mtg. Bushing (6 used)	.01
114-212	1st I.F. Trans.	.01
114-213	2nd I.F. Trans.	.01
114-214	3rd I.F. Trans.	.01
114-215	4th I.F. Trans.	.01
114-216	5th I.F. Trans.	.01
114-217	6th I.F. Trans.	.01
114-218	7th I.F. Trans.	.01
114-219	8th I.F. Trans.	.01
114-220	9th I.F. Trans.	.01
114-221	10th I.F. Trans.	.01
114-222	11th I.F. Trans.	.01
114-223	12th I.F. Trans.	.01
114-224	13th I.F. Trans.	.01
114-225	14th I.F. Trans.	.01
114-226	15th I.F. Trans.	.01
114-227	16th I.F. Trans.	.01
114-228	17th I.F. Trans.	.01
114-229	18th I.F. Trans.	.01
114-230	19th I.F. Trans.	.01
114-231	20th I.F. Trans.	.01
114-232	21st I.F. Trans.	.01
114-233	22nd I.F. Trans.	.01
114-234	23rd I.F. Trans.	.01
114-235	24th I.F. Trans.	.01
114-236	25th I.F. Trans.	.01
114-237	26th I.F. Trans.	.01
114-238	27th I.F. Trans.	.01
114-239	28th I.F. Trans.	.01
114-240	29th I.F. Trans.	.01
114-241	30th I.F. Trans.	.01
114-242	31st I.F. Trans.	.01
114-243	32nd I.F. Trans.	.01
114-244	33rd I.F. Trans.	.01
114-245	34th I.F. Trans.	.01
114-246	35th I.F. Trans.	.01
114-247	36th I.F. Trans.	.01
114-248	37th I.F. Trans.	.01
114-249	38th I.F. Trans.	.01
114-250	39th I.F. Trans.	.01
114-251	40th I.F. Trans.	.01
114-252	41st I.F. Trans.	.01
114-253	42nd I.F. Trans.	.01
114-254	43rd I.F. Trans.	.01
114-255	44th I.F. Trans.	.01
114-256	45th I.F. Trans.	.01
114-257	46th I.F. Trans.	.01
114-258	47th I.F. Trans.	.01
114-259	48th I.F. Trans.	.01
114-260	49th I.F. Trans.	.01
114-261	50th I.F. Trans.	.01
114-262	51st I.F. Trans.	.01
114-263	52nd I.F. Trans.	.01
114-264	53rd I.F. Trans.	.01
114-265	54th I.F. Trans.	.01
114-266	55th I.F. Trans.	.01
114-267	56th I.F. Trans.	.01
114-268	57th I.F. Trans.	.01
114-269	58th I.F. Trans.	.01
114-270	59th I.F. Trans.	.01
114-271	60th I.F. Trans.	.01
114-272	61st I.F. Trans.	.01
114-273	62nd I.F. Trans.	.01
114-274	63rd I.F. Trans.	.01
114-275	64th I.F. Trans.	.01
114-276	65th I.F. Trans.	.01
114-277	66th I.F. Trans.	.01
114-278	67th I.F. Trans.	.01
114-279	68th I.F. Trans.	.01
114-280	69th I.F. Trans.	.01
114-281	70th I.F. Trans.	.01
114-282	71st I.F. Trans.	.01
114-283	72nd I.F. Trans.	.01
114-284	73rd I.F. Trans.	.01
114-285	74th I.F. Trans.	.01
114-286	75th I.F. Trans.	.01
114-287	76th I.F. Trans.	.01
114-288	77th I.F. Trans.	.01
114-289	78th I.F. Trans.	.01
114-290	79th I.F. Trans.	.01
114-291	80th I.F. Trans.	.01
114-292	81st I.F. Trans.	.01
114-293	82nd I.F. Trans.	.01
114-294	83rd I.F. Trans.	.01
114-295	84th I.F. Trans.	.01
114-296	85th I.F. Trans.	.01
114-297	86th I.F. Trans.	.01
114-298	87th I.F. Trans.	.01
114-299	88th I.F. Trans.	.01
114-300	89th I.F. Trans.	.01
114-301	90th I.F. Trans.	.01
114-302	91st I.F. Trans.	.01
114-303	92nd I.F. Trans.	.01
114-304	93rd I.F. Trans.	.01
114-305	94th I.F. Trans.	.01
114-306	95th I.F. Trans.	.01
114-307	96th I.F. Trans.	.01
114-308	97th I.F. Trans.	.01
114-309	98th I.F. Trans.	.01
114-310	99th I.F. Trans.	.01
114-311	100th I.F. Trans.	.01
114-312	101st I.F. Trans.	.01
114-313	102nd I.F. Trans.	.01
114-314	103rd I.F. Trans.	.01
114-315	104th I.F. Trans.	.01
114-316	105th I.F. Trans.	.01
114-317	106th I.F. Trans.	.01
114-318	107th I.F. Trans.	.01
114-319	108th I.F. Trans.	.01
114-320	109th I.F. Trans.	.01
114-321	110th I.F. Trans.	.01
114-322	111th I.F. Trans.	.01
114-323	112th I.F. Trans.	.01
114-324	113th I.F. Trans.	.01
114-325	114th I.F. Trans.	.01
114-326	115th I.F. Trans.	.01
114-327	116th I.F. Trans.	.01
114-328	117th I.F. Trans.	.01
114-329	118th I.F. Trans.	.01
114-330	119th I.F. Trans.	.01
114-331	120th I.F. Trans.	.01
114-332	121st I.F. Trans.	.01
114-333	122nd I.F. Trans.	.01
114-334	123rd I.F. Trans.	.01
114-335	124th I.F. Trans.	.01
114-336	125th I.F. Trans.	.01
114-337	126th I.F. Trans.	.01
114-338	127th I.F. Trans.	.01
114-339	128th I.F. Trans.	.01
114-340	129th I.F. Trans.	.01
114-341	130th I.F. Trans.	.01
114-342	131st I.F. Trans.	.01
114-343	132nd I.F. Trans.	.01
114-344	133rd I.F. Trans.	.01
114-345	134th I.F. Trans.	.01
114-346	135th I.F. Trans.	.01
114-347	136th I.F. Trans.	.01
114-348	137th I.F. Trans.	.01
114-349	138th I.F. Trans.	.01
114-350	139th I.F. Trans.	.01
114-351	140th I.F. Trans.	.01
114-352	141st I.F. Trans.	.01
114-353	142nd I.F. Trans.	.01
114-354	143rd I.F. Trans.	.01
114-355	144th I.F. Trans.	.01
114-356	145th I.F. Trans.	.01
114-357	146th I.F. Trans.	.01
114-358	147th I.F. Trans.	.01
114-359	148th I.F. Trans.	.01
114-360	149th I.F. Trans.	.01
114-361	150th I.F. Trans.	.01
114-362	151st I.F. Trans.	.01
114-363	152nd I.F. Trans.	.01
114-364	153rd I.F. Trans.	.01
114-365	154th I.F. Trans.	.01
114-366	155th I.F. Trans.	.01
114-367	156th I.F. Trans.	.01
114-368	157th I.F. Trans.	.01
114-369	158th I.F. Trans.	.01
114-370	159th I.F. Trans.	.01
114-371	160th I.F. Trans.	.01
114-372	161st I.F. Trans.	.01
114-373	162nd I.F. Trans.	.01
114-374	163rd I.F. Trans.	.01
114-375	164th I.F. Trans.	.01
114-376	165th I.F. Trans.	.01
114-377	166th I.F. Trans.	.01
114-378	167th I.F. Trans.	.01
114-379	168th I.F. Trans.	.01
114-380	169th I.F. Trans.	.01
114-381	170th I.F. Trans.	.01
114-382	171st I.F. Trans.	.01
114-383	172nd I.F. Trans.	.01
114-384	173rd I.F. Trans.	.01
114-385	174th I.F. Trans.	.01
114-386	175th I.F. Trans.	.01
114-387	176th I.F. Trans.	.01
114-388	177th I.F. Trans.	.01
114-389	178th I.F. Trans.	.01
114-390	179th I.F. Trans.	.01
114-391	180th I.F. Trans.	.01
114-392	181st I.F. Trans.	.01
114-393	182nd I.F. Trans.	.01
114-394	183rd I.F. Trans.	.01
114-395	184th I.F. Trans.	.01
114-396	185th I.F. Trans.	.01
114-397	186th I.F. Trans.	.01
114-398	187th I.F. Trans.	.01
114-399	188th I.F. Trans.	.01
114-400	189th I.F. Trans.	.01
114-401	190th I.F. Trans.	.01
114-402	191st I.F. Trans.	.01
114-403	192nd I.F. Trans.	.01
114-404	193rd I.F. Trans.	.01
114-405	194th I.F. Trans.	.01
114-406	195th I.F. Trans.	.01
114-407	196th I.F. Trans.	.01
114-408	197th I.F. Trans.	.01
114-409	198th I.F. Trans.	.01
114-410	199th I.F. Trans.	.01
114-411	200th I.F. Trans.	.01
114-412	201st I.F. Trans.	.01
114-413	202nd I.F. Trans.	.01
114-414	203rd I.F. Trans.	.01
114-415	204th I.F. Trans.	.01
114-416	205th I.F. Trans.	.01
114-417	206th I.F. Trans.	.01
114-418	207th I.F. Trans.	.01
114-419	208th I.F. Trans.	.01
114-420	209th I.F. Trans.	.01
114-421	210th I.F. Trans.	.01
114-422	211st I.F. Trans.	.01
114-423	212nd I.F. Trans.	.01
114-424	213rd I.F. Trans.	.01
114-425	214th I.F. Trans.	.01
114-426	215th I.F. Trans.	.01
114-427	216th I.F. Trans.	.01
114-428	217th I.F. Trans.	.01
114-429	218th I.F. Trans.	.01
114-430	219th I.F. Trans.	.01
114-431	220th I.F. Trans.	.01
114-432	221st I.F. Trans.	.01
114-433	222nd I.F. Trans.	.01
114-434	223rd I.F. Trans.	.01
114-435	224th I.F. Trans.	.01
114-436	225th I.F. Trans.	.01
114-437	226th I.F. Trans.	.01
114-438	227th I.F. Trans.	.01
114-439	228th I.F. Trans.	.01
114-440	229th I.F. Trans.	.01
114-441	230th I.F. Trans.	.01
114-442	231st I.F. Trans.	.01
114-443	232nd I.F. Trans.	.01
114-444	233rd I.F. Trans.	.01
114-445	234th I.F. Trans.	.01
114-446	235th I.F. Trans.	.01
114-447	236th I.F. Trans.	.01
114-448	237th I.F. Trans.	.01
114-449	238th I.F. Trans.	.01
114-450	239th I.F. Trans.	.01
114-451	240th I.F. Trans.	.01
114-452	241st I.F. Trans.	.01
114-453	242nd I.F. Trans.	.01
114-454	243rd I.F. Trans.	.01
114-455	244th I.F. Trans.	.01
114-456	245th I.F. Trans.	.01
114-457	246th I.F. Trans.	.01
114-458	247th I.F. Trans.	.01
114-459	248th I.F. Trans.	.01
114-460	249th I.F. Trans.	.01
114-461	250th I.F. Trans.	.01
114-462	251st I.F. Trans.	.01
114-463	252nd I.F. Trans.	.01
114-464	253rd I.F. Trans.	.01
114-465	254th I.F. Trans.	.01
114-466	255th I.F. Trans.	.01
114-467	256th I.F. Trans.	.01
114-468	257th I.F. Trans.	.01
114-469	258th I.F. Trans.	.01
114-470	259th I.F. Trans.	.01
114-471	260th I.F. Trans.	.01
114-472	261st I.F. Trans.	.01
114-473	262nd I.F. Trans.	.01
114-474	263rd I.F. Trans.	.01
114-475	264th I.F. Trans.	.01
114-476	265th I.F. Trans.	.01
114-477	266th I.F. Trans.	.01
114-478	267th I.F. Trans.	.01
114-479	268th I.F. Trans.	.01
114-480	269th I.F. Trans.	.01
114-481	270th I.F. Trans.	.01
114-482	271st I.F. Trans.	.01
114-483	272nd I.F. Trans.	.01
114-484	273rd I.F. Trans.	.01
114-485	274th I.F. Trans.	.01
114-486	275th I.F. Trans.	.01
114-487	276th I.F. Trans.	.01
114-488	277th I.F. Trans.	.01
114-489	278th I.F. Trans.	.01
114-490	279th I.F. Trans.	.01
114-491	280th I.F. Trans.	.01
114-492	281st I.F. Trans.	.01
114-493	282nd I.F. Trans.	.01
114-494	283rd I.F. Trans.	.01
114-495	284th I.F. Trans.	.01
114-496	285th I.F. Trans.	.01
114-497	286th I.F. Trans.	.01
114-498	287th I.F. Trans.	.01
114-499	288th I.F. Trans.	.01
114-500	289th I.F. Trans.	.01
114-501	290th I.F. Trans.	.01
114-502	291st I.F. Trans.	.01
114-503	292nd I.F. Trans.	.01
114-504	293rd I.F. Trans.	.01
114-505	294th I.F. Trans.	.01
114-506	295th I.F. Trans.	.01
114-507	296th I.F. Trans.	.01
114-508	297th I.F. Trans.	.01
114-509	298th I.F. Trans.	.01
114-510	299th I.F. Trans.	.01
114-511	300th I.F. Trans.	.01
114-512	301st I.F. Trans.	.01
114-513	302nd I.F. Trans.	.01
114-514	303rd I.F. Trans.	.01
114-515	304th I.F. Trans.	.01
114-516	305th I.F. Trans.	.01
114-517	306th I.F. Trans.	.

MODELS K526W,
Y, Ch. 5K04

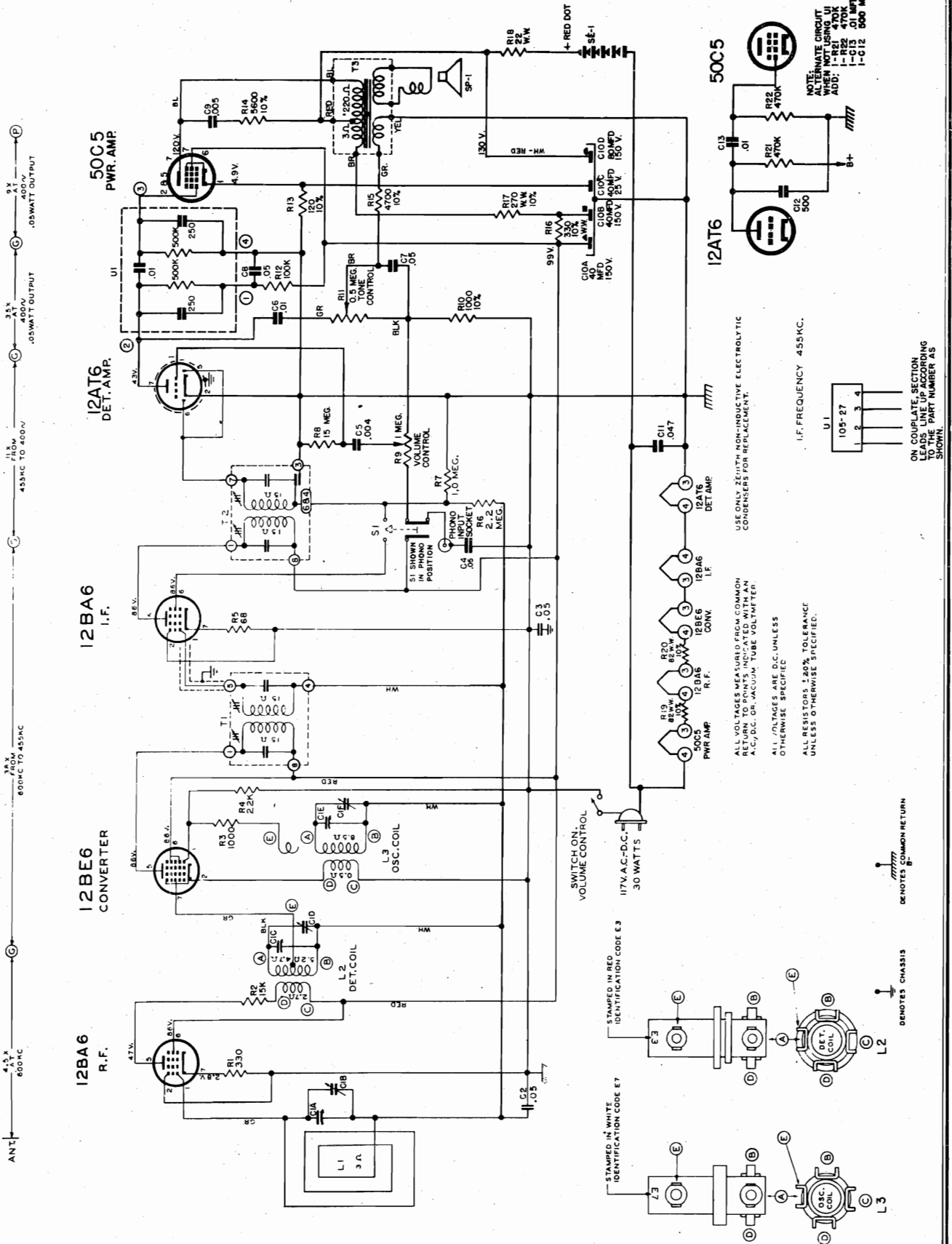

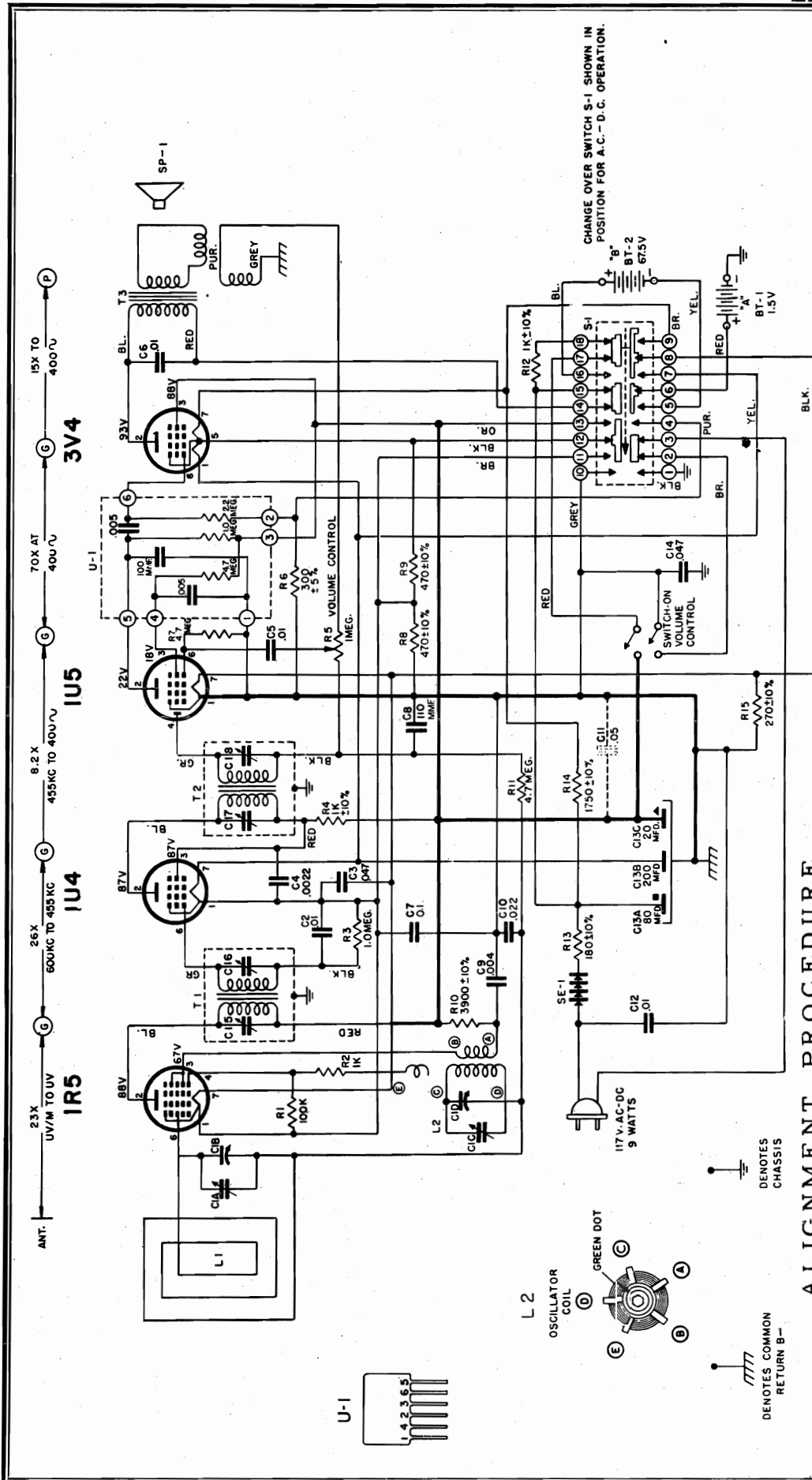

ALIGNMENT PROCEDURE

OPERATION	CONNECT OSCILLATOR TO	DUMMY ANTENNA	INPUT SIG. FREQUENCY	SET DIAL AT	TRIMMERS	PURPOSE
1	Converter Grid	.5 Mfd.	455 Kc.	600 Kc.	C15, 16, 17, 18	For I.F. Alignment
2	Single Turn Loosely Coupled to Wavemagnet	----	1600 Kc.	1600 Kc.	C1C	Set Oscillator to Dial Scale
3		----	1400 Kc.	1400 Kc.	C1A	Antenna Alignment

MODELS L403F,
G, R, Y, Ch. 4L41

MODEL L403Y, R, G, F				Cabinet Parts		
CHASSIS 4L41						
Part No.	Diag. No.	Description	Price			
11-104		Line Cord & plug - 7 ft.	.65	12-1958	Mounting bracket R.H. (used on cabinet front)	.10
12-1956		Gang - mtg. bracket	.15	12-1959	Mounting bracket L.H. (used on cabinet front)	.10
12-1957		Mtg. bracket (Power switch vol. control & rectifier)	.15	14-1522	Cabinet front L403Y (black)	3.00
17-128		Clamp (for Electrolytic)	.10	14-1523	Cabinet front L403R (maroon)	3.00
22-3	C2	.01 Mfd. Ceramic disc. 500V (3 used)	.26	14-1524	Cabinet front L403G (gray)	3.00
22-4	C9	.004 Mmfd. Ceramic disc. 500V	.26	14-1525	Cabinet front L403F (green)	3.00
22-5	C8	.110 Mmfd. Ceramic disc. 500V	.26	14-1526	Cabinet back L403Y	2.25
22-1775	C14	.047 Mfd. Molded P.D. 400V	.26	14-1528	Cabinet back L403R	2.25
22-1777	C7	.1 Mfd. Molded P.D. 200V	.26	14-1529	Cabinet back L403G	2.25
22-1778	C3	.047 Mfd. Molded P.D. 200V	.26	14-1530	Cabinet back L403F	2.25
22-1846	C6	.01 Mfd. Molded P.D. 400V	.20	16-866	Packing carton	
22-2072	C10	.022 Mfd. Molded P.D. 400V	.26	24-620	Cover (used on cabinet front)	.15
22-2161	C4	.0022 Mfd. Molded P.D. 200V	.26	36-6R	Handle L403Y	.50
22-2445	[C1A,C1B, C1C,C1D]	Two Section gang	3.50	36-69	Handle L403R	.50
22-2446	[C13A,C13B, C13C]	Electrolytic 80/150V 200/10V 20/150V	2.75	36-70	Handle L403G	.50
49-730	SP-1	Speaker 3 1/2 PM	5.00	36-71	Handle L403F	.50
52-633		Perforated twin conductor cable (for gang)		40-127	Hinge	.20
54-34		6-32x1/4 Hex nut (mt. 69-1)	.01	46-1084	Knob, volume (L403Y,R&F)	.30
54-139		3/8-32x9/16 Hex Nut (1 mt. 63-3168)	.01	46-1085	Knob, volume L403G	.30
54-267		6-32x5/16 Palnut (1 for 114-316)	.01	46-1089	Knob, tuning (L403Y,R&F)	.30
54-271		6-32x5/16 Hex Palnut (2 mt. ea. IF trans.)	.01	46-1090	Knob, tuning (L403G)	.30
63-1761	R15	270 ohm 1/2 W Ins. 10%	.21	54-338	Speed Nut (2 used)	.04
63-1762	R6	300 ohm 1/2 W Ins. 5%	.21	54-339	Speed Nut	.04
63-1771	R8	470 ohm 1/2 W Ins. 10% (2 used)	.21	57-1721	Emblem plate (L403Y,R&F)	.25
63-1785	R12	1 K ohm 1/2 W Ins. 10% (2 used)	.21	57-1904	Emblem plate (L403G)	.25
63-1786	R2	1 K ohm 1/2 W Ins. 20%	.21	59-288	Dial pointer	.20
63-1810	R10	3900 ohm 1/2 W Ins. 10%	.21	64-5	1/8x7/32 Rivet (Part of S-19581)	.01
63-1870	R1	100 K ohm 1/2 W Ins. 20%	.21	64-6	1/8x3/16 Rivet (Part of S-19581)	.01
63-1912	R3	1 Megohm 1/2 W Ins. 20%	.21	64-7	1/8x5/32 Rivet (Part of S-19581)	.01
63-1940	R11	4.7 Megohm 1/2 W Ins. 20% (2 used)	.21	64-27	1/8x1/8 Rivet (Part of S-19581)	.01
63-2819	R14	1750 ohm 5 WW Ins. 10%	.75	80-903	Ground spring (used on cabinet back)	.03
63-2821	R13	180 ohm 4 WW Ins. 10%	.40	80-932	Latch spring (used on cabinet back)	.10
63-3168	R5	Volume control & switch	1.81	80-933	Contact spring (Part of S-19581)	.15
64-27		1/8 Dia x 1/8 Rivet (3 used)	.01	83-2083	Armite strip (used with cabinet handle)	.04
64-151		.088 Dia x 3/32 Rivet (2 mt. ea. 78-782)	.01	83-2084	Battery contact strip (Part of S-19581)	.04
64-246		Brass eyelet (1 used with Electrolytic)	.01	83-2087	Contact mtg. strip (Part of S-19581)	.15
69-1	6-32 x 1 1/2	Rd Hd Mach. Screw (1 mt. 63-2819)	.03	86-30	Terminal (Part of S-19581)	.02
69-259		8-32x3/8 Phil Rd Hd Mach Screw (1 mt. 49-730)	.02	86-221	Terminal (Part of S-19581)	.02
78-782		Socket, 7 contact molded min. (4 used)	.25	93-975	Washer (Part of S-19581)	.01
83-1513		B Battery term strip	.25	112-880	6-20x5/16 phil pan hd self tap screw (3 mt. hinge)	.02
83-2081		Armite strip (used with 212-5)	.20	112-889	6-32x 1/2 phil pan hd self tap screw (1 mt. chassis)	.04
85-454	S-1	Power change over switch	2.00	112-900	6-20x3/8 phil pan hd self tap screw (3 used)	.02
93-125		6 int. lockwasher (69-1)	.01	114-192	6-20x7/16 hex hd self tap screw (4 mt. chassis)	.01
93-126		8 int. lockwasher (69-259)	.01	114-248	6-20x5/16 hex hd self tap screw (2 mt. handle)	.01
93-1020		Fibre washer (2--69-1)	.01	114-294	6-20x1/4 hex hd self tap screw (mt. shield)	.02
94-334		Gang mtg. bushing (3 used)	.01	114-297	6-32x1/4 hex hd self tap screw (4 mt. 24-620 1 ea. 12-1958 & 9)	.01
94-812		Coil insert (Part of Osc. coil)	.05	114-421	5-40 x 1/4 hex hd self tap screw (4 mt. grille)	.02
95-1330	T1	1st. IF transformer	1.85	126-709	Shield plate	.15
95-1331	T2	2nd IF transformer	1.85	138-63	Cabinet grille (L403Y & R&F)	1.75
95-1332	T3	Output transformer	2.00	138-65	Cabinet grille (L403G)	1.75
105-31	U-1	Couplate unit	.90	159-86	Trimount (3 mt. shield)	.01
113-10		6-32x3/16 Hex hd. mach. screw (2 mt. 12-1957)	.02	199-177	Line cord sleeve	.06
113-40		6-32x1/4 Phil rd hd. mach screw (2 mt. 12-1956)	.02	202-956	Instruction book	.20
113-15		6-32x5/16 Hex hd mach screw (3 mt. gang)	.02	S-19581	Battery carrier assem.	.55
114-275		6-32x5/16 Hex hd mach screw (1 mt. 22-2446)	1.20	S-19584	Wavemagnet	2.25
114-297		6-32x1/4 hex hd self tap screw (5 used speaker)	.01	S-19638	Bracket & strip (Part of S-19581)	.10
114-316		6-32x1-1/4 hex hd mach screw (1 mt. 212-5)	.02	S-19639	Bracket & bushing (for handle used on cab. front)	.10
125-47		Rubber grommet (3 mt. gang)	.03			
125-81		Strain relief grommet (11-104)	.05			
125-82		Strain relief grommet (11-104)	.05			
126-706		Shield	.15			
149-85		Iron core (Part of Osc. coil S-19960)	.10			
212-5	SE-1	Selenium rectifier 75 MA	1.80			
S-19660	L2	Oscillator coil				

TUBE AND TRIMMER LOCATION

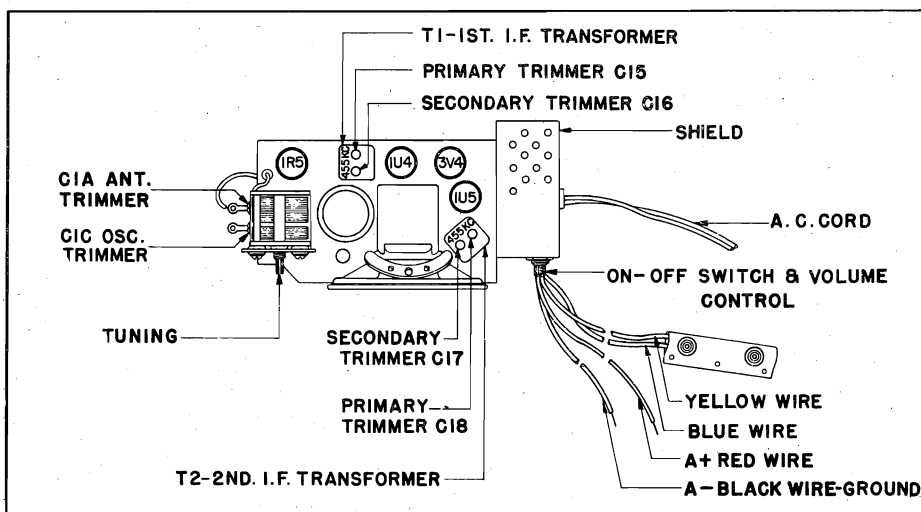

MODELS L518, F,
G, W, Y, Ch. 5L03

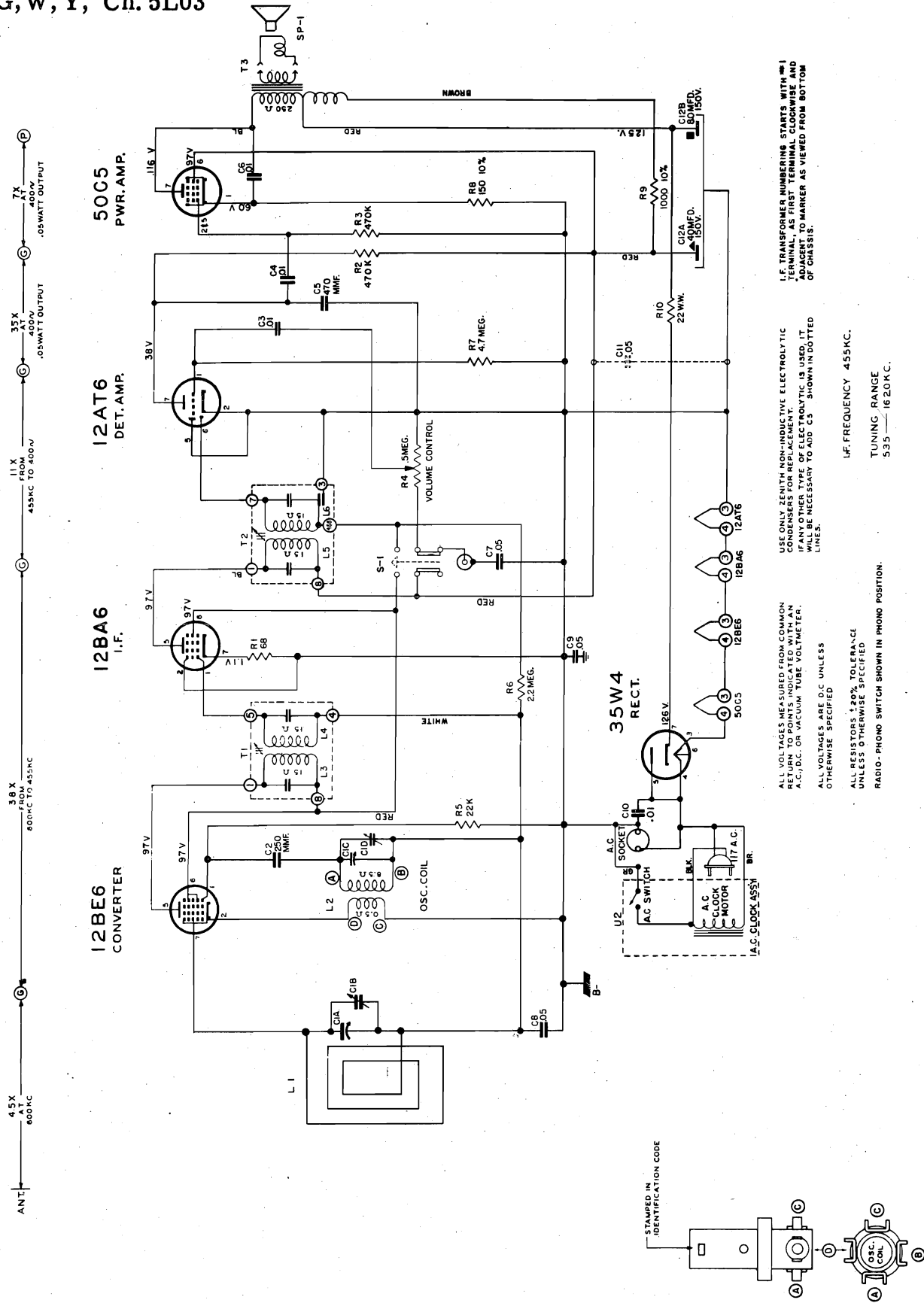

IF TRANSFORMER NUMBERS STARTS WITH 101 TERMINAL, AS FIRST TERMINAL CLOCKWISE AND ADJACENT TO MARKER AS VIEWED FROM BOTTOM OF CHASSIS.

USE ONLY ZENITH NON-INDUCTIVE ELECTROLYTIC CONDENSERS FOR REPLACEMENT. IF ANY OTHER TYPE OF ELECTROLYTIC IS USED, IT LINE IS NECESSARY TO ADD C5 SHOWN IN DOTTED LINE.

ALL VOLTAGES MEASURED FROM COMMON RETURN TO POINTS INDICATED WITH AN A.C., D.C. OR VACUUM TUBE VOLTMETER. ALL VOLTAGES ARE D.C. UNLESS OTHERWISE SPECIFIED

ALL RESISTORS 120% TOLERANCE UNLESS OTHERWISE SPECIFIED

RADIO - PHONO SWITCH SHOWN IN PHONO POSITION.

IF.F. FREQUENCY 455KC.
TUNING RANGE
5.35 — 16.20 KC.

⊥ DENOTES CHASSIS
⊥ DENOTES COMMON RETURN

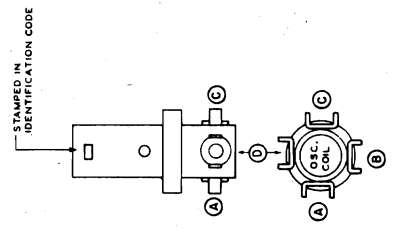

Clock and Timer Note:

The clock and timer assemblies used in this receiver are manufactured by Telechron. Face parts, such as hands, knobs, scales, bezel, etc., are not available through local Telechron service depots. We suggest that all clock and timer assemblies complete (less the rear cover and bushing) be returned to your local Zenith Distributor for repair or replacement. Be sure to pack all clock and timer assemblies individually and carefully to prevent damage in shipment.

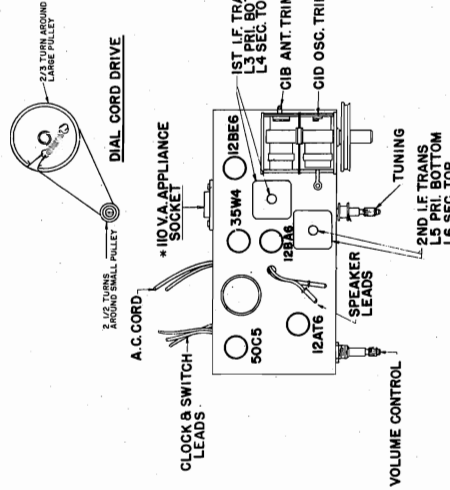

46-985	46-1222	46-1224	46-1225	46-1226	46-1262	49-713	54-277	57-1721	57-1854	57-1855	57-1856	57-1857	57-2004	59-280	59-281	59-282	93-501	93-805	102-792	112-773	112-829	114-294	114-297	114-395	188-102	192-155	196-208	202-999	S-19224 U1	S-19225 U1	S-19226 U1	S-19227 U1	S-19262	S-20558 L1	S-20988
Knob, alarm - radio - auto off L520G (3 used)	Knob, volume - tuning (2 used) L520	Knob, volume - tuning L520W (2 used)	Knob, volume - tuning L520G (2 used)	Knob, volume - tuning L520F (2 used)	Knob, volume tuning L520R (2 used)	Speaker "A" PM	Hex nut (3 mt. S-19262)	Emboss plate	Dial background plate L520G	Dial background plate L520W	Dial background plate L520	Dial background plate L520F	Dial background plate L520R	Pointer L520G, F, R	Pointer L520W	Pointer L520	#4 int. lockwasher (1 mt. 19-208)	Steel washer (1 mt. 19-208)	Clock set instruction label	6-20 x 3/8 phill pan hd self tap screw (4 mt. wavemagnet & back)	10-32 x 1/2 truss hd mach screw (2 mt. chassis)	6-20 x 1/4 hex hd self tap screw (2 mt. speaker)	6-32 x 1/4 hex hd self tap screw (2 mt. dial backgd. plate)	6-20 x 5/16 hex hd self tap screw (1 mt. dial backgd. plate, 2 mt. clock assem.)	Clamping ring (for pointer)	Crystal (2 used)	Radio crystal gasket	Instruction book	Clock assem. L520G	Clock assem. L520W	Clock assem. L520	Clock assem. L520F	Clock cover assem.	Wavemagnet & back assem.	Clock assem. L520R
.25	.25	.25	.25	.25	4.50	.01	.25	.25	.70	.70	.70	.70	.30	.30	.30	.01	.01	.02	.03	.02	.02	.01	.05	.02	.35	.25	13.50	13.50	13.50	13.50	.30	1.50			

Prices shown are suggested list prices and are subject to change without notice.

ALIGNMENT PROCEDURE

OPERATION	CONNECT OSCILLATOR TO	DUMMY ANTENNA	INPUT SIG. FREQUENCY	SET DIAL AT	TRIMMERS	PURPOSE
1	Converter Grid	.5 Mfd.	455 Kc.	600 Kc.	L3, 4, 5, 6	For I. F. Alignment
2	One Turn Loop Coupled Loosely to Wave Magnet	---	1600 Kc.	1600 Kc.	CID	Set Oscillator to Dial Scale
3		---	1400 Kc.	1400 Kc.	CIB	Align Antenna Stage

PART NO.	DIAG. NO.	DESCRIPTION	PRICE
11-111		Line cord & plug	1.15
22-3	C3, C5, C9	.01 mid ceramic disc. 500V (3 used)	.26
22-6	C4	.00047 mid ceramic disc. 500V	.26
22-829	C7, C8, C10	.05 mid 200V (2 used)	.20
22-1182	C6	.01 mid 400V	.20
22-1666	C2	250 mmfd ceramic 500V	.25
22-2351	C11A, C11B	Electrolytic 80/150V 40/150V	2.40
22-2386	C1A, C1B	Two section variable	3.00
54-139		Paint (1 mt. 63-2393)	.01
54-271		Paint (1 mt. ea. 95-1101, 95-1102)	.01
63-965	R9	1 K ohm 1 W ins. 10%	.24
63-1450	R10	22 ohm 1 W W ins. 20%	.24
63-1737	R2	68 ohm 1/2 W ins. 20%	.21
63-1842	R1	22 K ohm 1/2 W ins. 20%	.21
63-1898	R6, R7	470 K ohm 1/2 W ins. 20% (2 used)	.21
63-1926	R4	2.2 meg ohm 1/2 W ins. 20%	.21
63-1940	R5	4.7 meg ohm 1/2 W ins. 20%	.21
63-1977	R8	150 ohm 1 W ins. 10%	.24
63-2393	R3	Volume control	1.20
78-275		Socket, electrolytic	.03
78-806		Socket, min. tube (4 used)	.15
78-807		Socket, min. tube	.15
78-840		Socket, two contact	.30
80-209		Dial cord tension spring	.03
83-1861		Line cord terminal strip	.10
83-1862		Line cord insulating	.05
93-2-295		Brass washer (2 mt. 95-1354)	.04
95-1101	T1	Gang mtg. bushing (3 used)	1.60
95-1102	T2	1st IF transformer	3.00
95-1354	T3	Output transformer	3.00
113-13		6-32 x 7/16 hex hd mach screw (2 mt. gang)	.02
114-67		6-32 x 7/16 hex hd mach screw (1 mt. gang)	.01
123-17		Rubber grommet (3 mt. gang)	.03
166-65		Rubber bumper (gang)	.02
188-149		Retaining ring (for S-18514)	.06
S-18509		Dial cord & eyelet	.35
S-18514		Tuning shaft & pulley	.70
S-18616	L2	Oscillator coil assem.	.20
S-19240		Twisted wire cable	

Cabinet Parts

14-1621	Cabinet, plastic table model L520	7.00
14-1623	Cabinet, plastic table model L520W	9.00
14-1624	Cabinet, plastic table model L520G	9.00
14-1625	Cabinet, plastic table model L520F	9.00
14-1647	Cabinet, plastic table model L520R	
16-942	Packing carton	.02
19-208	Cable clamp	.65
26-480	Radio dial scale L520, W, G, F	.55
26-481	Clock dial scale L520, W, G, F	.25
46-904	Knob, alarm - radio - auto off (3 used) L520	.25
46-905	Knob, alarm - radio - auto off L520R (3 used)	.25
46-940	Knob, alarm - radio - auto off L520W (3 used)	.25
46-951	Knob, alarm - radio - auto off L520F (3 used)	.25

Clock and Timer Note:

The clock and timer assemblies used in this receiver are manufactured by Telechron. Face parts, such as hands, knobs, scales, bezel, etc., are not available through local Telechron service depots. We suggest that all clock and timer assemblies complete (less the rear cover and bushing) be returned to your local Zenith Distributor for repair or replacement. Be sure to pack all clock and timer assemblies individually and carefully to prevent damage in shipment.

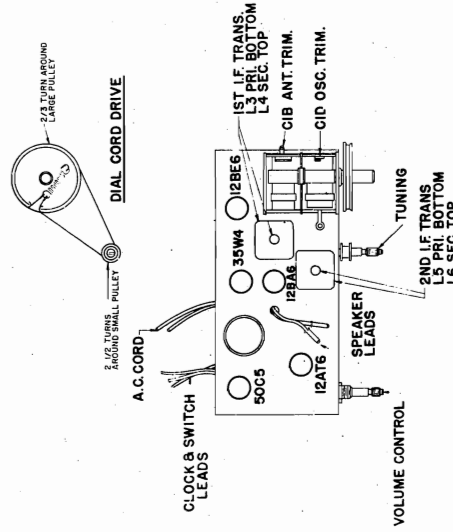

Cabinet Parts

- Cabinet - plastic table model L515Y .45
- Cabinet - plastic table model L515 .45
- Cabinet - plastic table model L515W 6.50
- Cabinet - plastic table model L515F 6.50
- Cabinet - plastic table model L515G 6.50
- Packing carton .02
- Cable clamp .45
- Dial scale .25
- Knob, alarm - radio - auto off (3 used) L515 .25
- Knob, alarm - radio - auto off (3 used) L515Y, W.F.G 25
- Knob, volume - tuning (2 used) L515Y, W.F.G .20
- Knob, volume - tuning (2 used) L515 .20
- Speaker 4" PM 4.50
- Hex nut (3 mt. S-18925) .01
- Clock escutcheon .40
- Dial pointer L515 .30
- #4 int. lockwasher (for 19-208) .01
- Steel washer (for 19-208) .01
- Clock set instruction label .02
- 10-32 x 1/2 truss hd mach screw (2 mt.chassis) .02
- 6 x 5/16 hex hd self tap screw (2 mt-speaker) .01
- 6-20 x 5/16 hex hd self tap screw (5 mt. S-18925) .05
- Trimount stud (4 mt. wavemagnet & back) .01
- Clamping ring (for 59-265 or 59-267) .04
- Clock crystal .15
- Crystal gasket .20
- Instruction book 13.50
- Clock assem. L515 13.50
- Clock assem. L515Y, W.F.G 35
- Clock cover assem. 1.50
- Wavemagnet & back assem.

Prices shown are suggested list prices and are subject to change without notice.

ALIGNMENT PROCEDURE

OPERATION	CONNECT OSCILLATOR TO	DUMMY ANTENNA	INPUT SIG. FREQUENCY	SET DIAL AT	TRIMMERS	PURPOSE
1	Converter Grid	.5 Mfd.	455 Kc.	600 Kc.	L 3,4,5,6	For I.F. Alignment
2	One Turn Loop Coupled Loosely to Wave Magnet	---	1600 Kc.	1600 Kc.	CID	Set Oscillator to Dial Scale
3		---	1400 Kc.	1400 Kc.	CIB	Align Antenna Stage

PART NO.	DIAG. NO.	DESCRIPTION	PRICE
11-104		Line cord & plug	.65
22-5	C3,C5,C9	.01 mid ceramic disc, 500V (3 used)	.26
22-6	C4	.00047 mid ceramic disc, 500V	.26
22-829	C7,C8,C10	.05 mid 200V (2 used)	.20
22-1182	C6	.01 mid 400V	.20
22-1666	C2	250 mmd ceramic 500V	.25
22-2351	C11A,C11B	Electrolytic 80/150V 40/150V	3.00
22-2386	C1A,C1B,	Two section variable	
54-139		Paint (used on volume control)	.01
54-271		Pinout (1 mt. ea. 95-1101, 1102)	.24
63-965	R9	1 K ohm 1 W ins. 10%	.34
63-1450	R10	22 ohm 1 W W ins. 20%	.21
63-1737	R2	68 ohm 1/2 W ins. 20%	.21
63-1842	R1	22 K ohm 1/2 W ins. 20%	.21
63-1898	R6,R7	470 K ohm 1/2 W ins. 20% (2 used)	.21
63-1926	R4	2.2 meg ohm 1/2 W ins. 20%	.21
63-1940	R5	4.7 meg ohm 1/2 W ins. 20%	.24
63-1977	R8	150 ohm 1 W ins. 10%	1.20
63-2393	R3	Volume control	.03
78-275		Socket, electrolytic	.15
78-806		Socket, min tube (4 used)	.03
80-209		Socket, min tube	.03
83-792		Line cord insulating strip	.03
94-295		Brass washer (2 mt. 95-1354)	.01
95-1101	T1	1 st I F transformer	1.60
95-1102	T2	2 nd I F transformer	1.60
95-1354	T3	Output transformer	3.00
113-13		6-32 x 7/16 hex hd mach screw (2 mt.gang)	.02
114-67		6-32 x 7/16 hex hd mach screw (1 mt.gang)	.01
125-17		Rubber grommet (3 mt.gang)	.03
166-65		Rubber bumper (gang)	.02
188-149		Retaining ring (for S-18514)	.06
S-18509		Dial cord & eyelet	.35
S-18514		Tuning shaft & pulley	.70
S-18616	L2	Oscillator coil assem.	
S-19291		Twisted wire cable	.25

